

# Keysight Technologies

## E4990A Impedance Analyzer

20 Hz to 10/20/30/50/120 MHz



## Standard Three-Year Warranty

Get greater reliability – Keysight’s three-year world-wide warranty on all impedance analyzers. Keysight’s combination of reliability and coverage delivers three key benefits:

- Increased confidence
- Reduced cost of ownership
- Greater convenience



## Keysight Impedance Analyzer Series

### Achieve success with the industry standard for impedance measurements

Hewlett Packard, Agilent and Keysight Technologies, Inc. have contributed innovations and product excellence in impedance analysis for over half a century. Whether your application is in R&D, production, quality assurance, or incoming inspection, we take pride in contributing to your success. We strive to deliver complete solutions to meet your needs, from impedance analyzers to a wide variety of test accessories. Achieve success with Keysight’s impedance measurement solutions.

### Real characteristics - achieved only with an impedance analyzer

Only Keysight impedance analyzers provide unparalleled accuracy for component evaluation mOhm to Mohm, from 5 Hz to 3 GHz. Add an impedance analyzer to your lab and achieve real characteristics of high quality components.

### Select the appropriate frequency range for your application

Keysight’s impedance analyzers provide the best performance in the industry with frequency options to meet your needs at an affordable price. You can select the most appropriate frequency range for your application, from 10 MHz to 3 GHz. Flexible frequency upgrade options are also available. You can choose just what you require today with the least amount of investment and upgrade later as needs arise. Select what’s best for you - and achieve both your engineering and business goals.

### E4990A Impedance analyzer

- Impedance analyzer
- Auto balancing bridge
- Basic accuracy 0.08% (typ. 0.045%)
- Z-range: 25 mΩ – 40 MΩ (10% accuracy)

Option 120	20 Hz to 120 MHz
Option 050	20 Hz to 50 MHz
Option 030	20 Hz to 30 MHz
Option 020	20 Hz to 20 MHz
Option 010	20 Hz to 10 MHz

### E4991B Impedance analyzer

- Impedance analyzer
- RF-IV method
- Basic accuracy 0.65%
- Z-range: 120 mΩ – 52 kΩ (10% accuracy)
- Direct readout of material parameters

Option 300	1 MHz to 3 GHz
Option 100	1 MHz to 1 GHz
Option 050	1 MHz to 500 MHz

### E5061B ENA Series network analyzer with Options 3L5 and 005

- LF-RF network analyzer (Option 3L5) with impedance analysis (Option 005)
- Basic accuracy 2% (typical)
- Z-range: 1 Ω – 2 kΩ (10% accuracy, typical S-parameter port)
- Gain/Phase evaluation

5 Hz to 3 GHz
---------------

# Keysight E4990A Impedance Analyzer

The E4990A impedance analyzer has a frequency range of 20 Hz to 120 MHz. The E4990A provides an industry best 0.045% (typical) basic accuracy over a wide impedance range with a 40 V built-in DC bias source. The equivalent circuit analysis function supports seven different multi-parameter models and helps you to simulate your own equivalent parameter values of components.

Five frequency options (20 Hz to 10/20/30/50/120 MHz) and frequency upgrades allow you to choose the most appropriate option with the least amount of investment.

The E4990A supports a variety of test accessories that are designed to make measurements simple and reliable.

Whether you are in R&D, QA, or inspection, the E4990A is an ideal solution for characterizing and evaluating electronic components, semiconductor devices, and materials.



## Application examples:

### Passive components

Impedance measurement of capacitors, inductors, ferrite beads, resistors, transformers, or crystal/ceramic resonators

### Semiconductor components

C-V characteristics analysis of varactor diodes. Impedance evaluation of diodes, transistors, amplifiers, or MEMS.

### Other components

Impedance evaluation of components on printed circuit boards.

### Dielectric material

Permittivity and loss tangent evaluation of plastics, ceramics, and printed circuit boards.

### Magnetic material

Permeability and loss tangent evaluation of ferrite, amorphous.

## Summary of Key Specifications

Operating frequency	20 Hz to 10/20/30/50/120 MHz (Option 010/020/030/050/120 respectively)
Measurement parameters	Z ,  Y , $\theta$ , R, X, G, B, L, C, D, Q, Complex Z, Complex Y, Vac, Iac, Vdc, Idc
Basic impedance accuracy	$\pm 0.08\%$ (typical $\pm 0.045\%$ )
Q accuracy	$\pm 3\%$ (typical) at Q = 100, frequency $\leq 10$ MHz
Impedance range	25 m $\Omega$ to 40 M $\Omega$ (10% accuracy)
Measurement time	3 msec/point at Option 120, frequency $\geq 100$ kHz, measurement time = 1 (fast) 30 msec/point at Options 010/020/030/050, freq. $\geq 100$ kHz, measurement time = 1 (fast)
Measurement type	Four-terminal-pair measurement (standard) 7-mm 1-port measurement with 42942A measureable grounded devices <sup>1</sup> Impedance probe measurement with 42941A measureable grounded devices <sup>1</sup>
Voltage/current signal level	5 mVrms to 1 Vrms /200 $\mu$ Arms to 20 mArms, 1 mV/20 $\mu$ A resolution
DC bias	0 to $\pm 40$ V/ $\pm 100$ mA, 1 mV/40 $\mu$ A resolution
Auto level control (ALC)	Signal level voltage/current, DC bias voltage/current
Sweep parameters	Frequency, signal voltage/current, DC bias voltage/current
Sweep type	Linear frequency, log frequency, linear signal level, linear DC bias, log DC bias, segment
Number of measurement points	2 to 1601
Number of channels/traces	4-channel/4-trace
Marker	10 independent markers per trace, delta marker, marker search, marker analysis
Data analysis	Equivalent circuit analysis, limit line test
Interface	USB (front 2, rear 4), LAN, USBTMC, GPIB, 24 bit I/O
Display	10.4 inch TFT color LCD with touch screen

1. Option 120 only

# Truly User Friendly – Front Panel

The E4990A has a simple and intuitive user interface that allows you to make accurate repeatable measurements. View multiple parameters under various conditions at the same time on the large touch screen display. Frequently used functions are easily accessed through front panel hardkeys and softkeys that are organized for quick and easy navigation. Sophisticated analysis functions are available for better insight into your designs.

View 4-channels/4-traces on the 10.4 inch XGA color LCD with touch screen

User-friendly interface and help menu using the front-panel keys, or mouse and keyboard

Quick access to all necessary functions for basic measurements with Instr Setup key

Embedded context-sensitive help

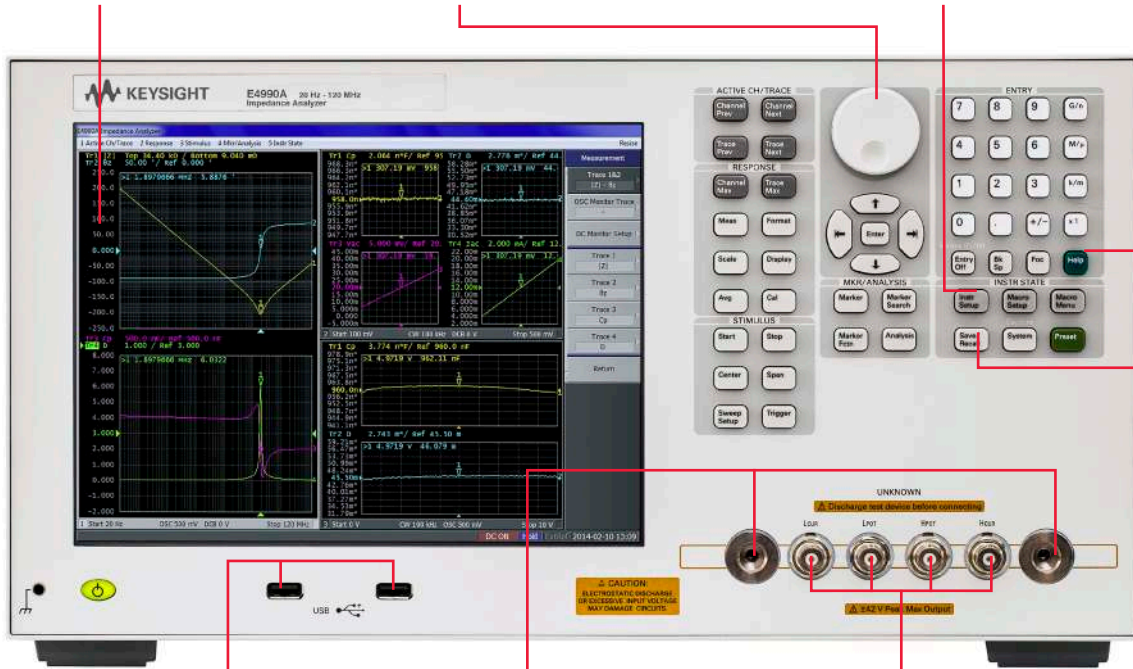

Two USB ports located on the front of the instrument

Rigid fixture/Accessory connection

Four-terminal-pair measurement configuration and auto-balancing technique

Quick save and recall data and setup files on SSD

Get answers quickly with the comprehensive context sensitive embedded help

- The Help menu includes everything you need — Quick Start Guide, Operation Manual, and Programming Manual
- Context-sensitive help allows you to quickly get information about selected softkeys
- When using command finder in the programming manual, you can quickly find SCPI commands with a one-key operation

Contents | Index | Search

- Home
- Using this Help
- Precautions
- Quick Start
- Measurement
  - Preparation of Measurement Accessor
  - Setting Measurement Conditions
    - Initializing Parameters
    - Setting Channels and Traces
    - Selecting Sweep Parameter
    - Setting Source
    - Setting Trigger
  - Calibration
  - Setting Up the Display of Measurements
  - Analysis and Processing of Result
  - Outputting Data
- Setting Control Functions
- Using Windows
- Product Information
- Programming

### Setting Sweep Range Using the Marker

1. Press **Marker Fctn**, then input the center value.
2. Click the softkey that corresponds to each value.

Softkey	Function
<b>Marker → Start</b>	Sets the lowest value to the stimulus value of the active marker on the currently active trace.
<b>Marker → Stop</b>	Sets the highest value to the stimulus value of the active marker on the currently active trace.
<b>Marker → Center</b>	Sets the center value to the stimulus value of the active marker on the currently active trace.

**NOTE** If the reference marker is on and the stimulus value of the active marker is expressed by a value relative to the reference marker, the absolute stimulus value will be used to set the new sweep range.

Marker → Start

Marker → Stop

## Truly User Friendly – Side and Rear Panel

Powerful yet compact, the E4990A will complement any existing testing environment and requires a minimal amount of space.

The high stability frequency reference (Option 1E5) allows you to improve the frequency accuracy and stability of the E4990A.

The E4990A provides flexible connectivity for remote control and easy test automation. Load measurement data from the E4990A to your PC via GPIB, LAN, or USB (type-B) interface. Digital I/O port (24 bit) is also available for data transfer with an external device, such as a handler.

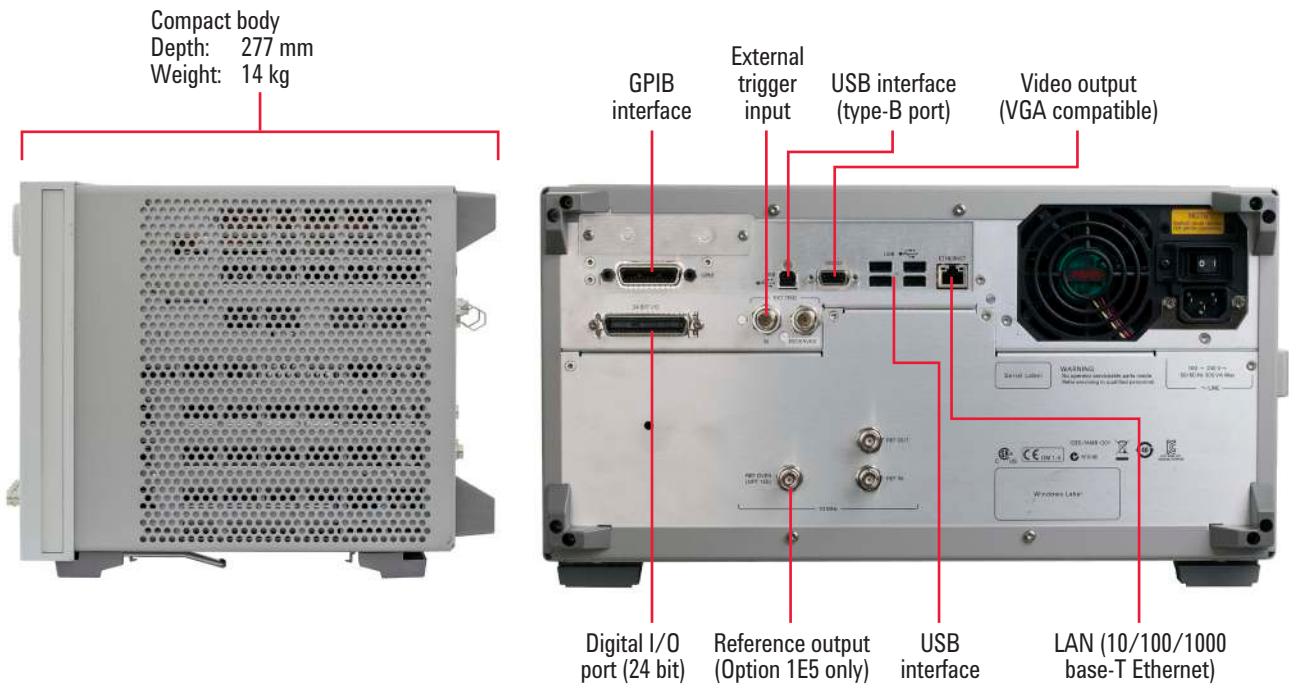

## Web server/control example

Conveniently control the E4990A with your PC and web browser via a LAN interface.

Remotely control the E4990A and acquire measurement data without any programming experience.

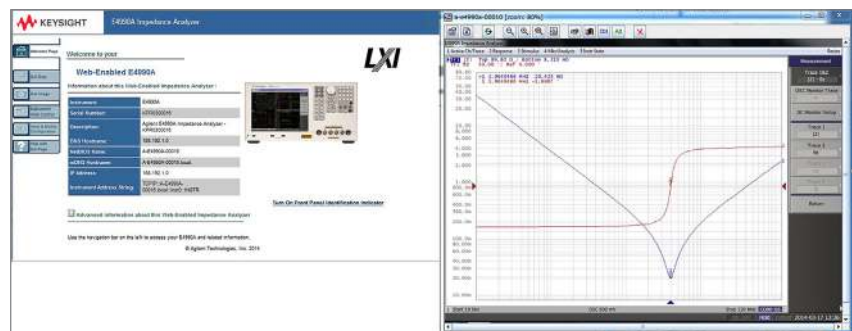

# Real-World Characterization Under Various Operating Conditions

## Comprehensive analysis using multi-channel/multi-trace

The 4-channel/4-trace capability helps you setup and measure multiple parameters under various operating conditions, such as frequency, test signal level, and DC level dependency. The measurement results can be enlarged on the display with one touch.

## Frequency dependency

Frequency dependency is common in all components because of the existence of parasitics. The E4990A can sweep test frequencies from 20 Hz to 120 MHz over a wide impedance range. It enables accurate evaluation of the frequency response including

the self-resonant frequency point of components, such as capacitors and inductors.

## Test signal level dependency

The test signal (AC) applied may affect the impedance characteristics of some devices. The E4990A can sweep test signal voltage from 5 mVrms to 1 Vrms (1 mV resolution), or test signal current from 200  $\mu$ Arms to 20 mArms (20  $\mu$ A resolution) to evaluate test signal level dependency. The E4990A's ALC function accurately maintains the applied test signal voltage or test signal current. While the impedance of a device might change during a sweep, the ALC function insures that the signal level setting is the actual signal level applied to the DUT.

## DC level dependency

DC level dependency is common in semiconductor components such as diodes and transistors. Some passive components are also DC level dependent. The E4990A can sweep DC voltage bias from  $-40$  V to  $+40$  V (1 mV resolution), or DC current bias from  $-100$  mA to  $+100$  mA (40  $\mu$ A resolution) to evaluate DC signal dependency. The ALC automatically maintains the applied DC voltage bias or current bias.

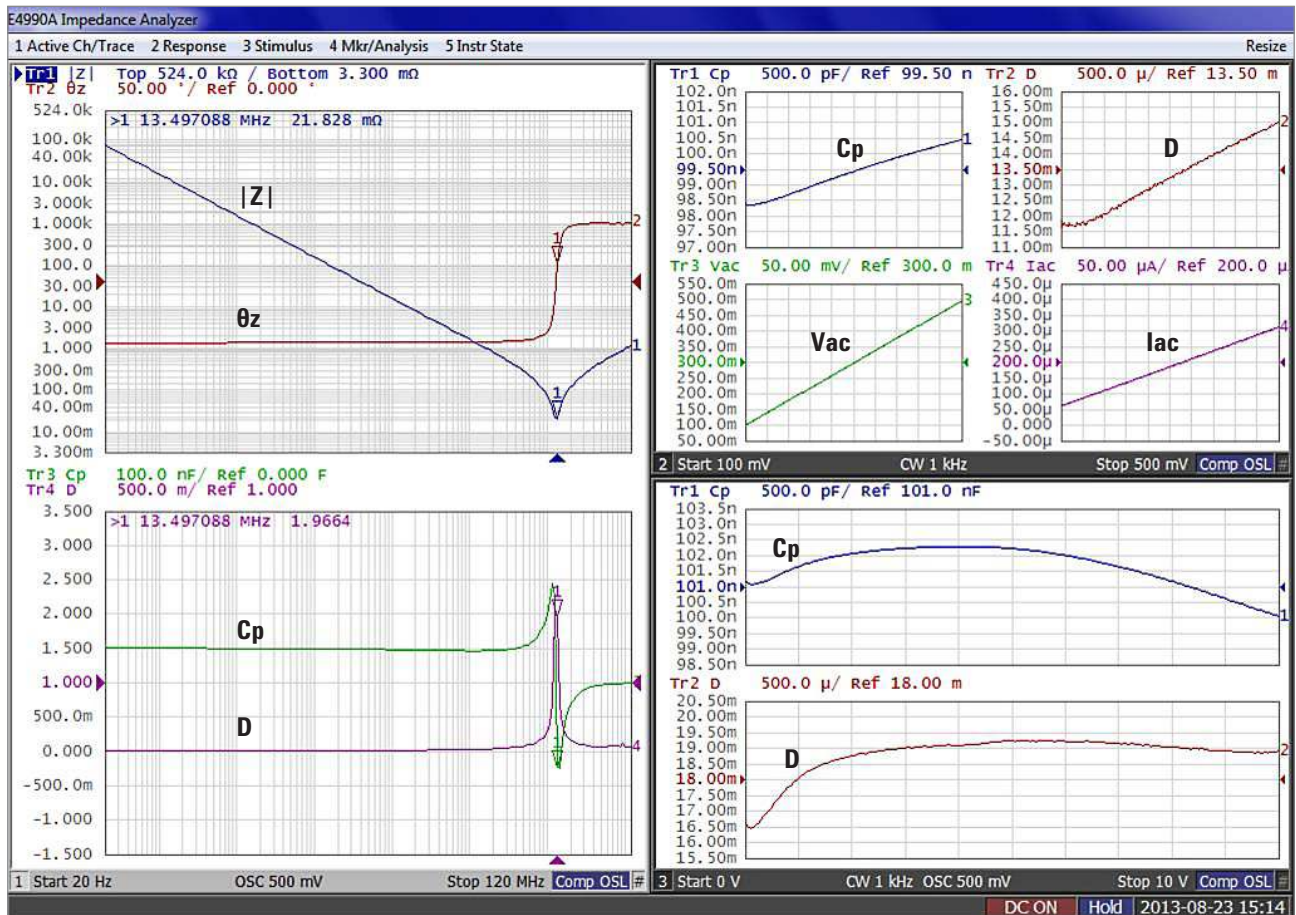

Left: Frequency dependency (0.1  $\mu$ F capacitor, frequency swept from 20 Hz to 120 MHz, OSC level = 500 mV)

Upper right: Test signal level dependency (0.1  $\mu$ F capacitor, signal-level swept from 100 mV to 500 mV, frequency = 1 kHz)

Lower right: DC level dependency (0.1  $\mu$ F capacitor, DC-level swept from 0 V to 10 V, frequency = 1 kHz, OSC level = 500 mV)

## Segment Sweep for Efficient Analysis

The segment sweep function allows you to divide the sweep range into segments. Each segment, including the frequency range, number of points, averaging factor, test signal level, and DC bias can be set independently. This can be achieved with a single sweep. The segment sweep setting can also be exported to a CSV file.

Evaluation of a crystal resonator requires that the nominal resonant/anti-resonant frequencies and some spurious frequencies be determined. You can perform a sweep measurement for a specific range, eliminating the ranges that aren't needed.

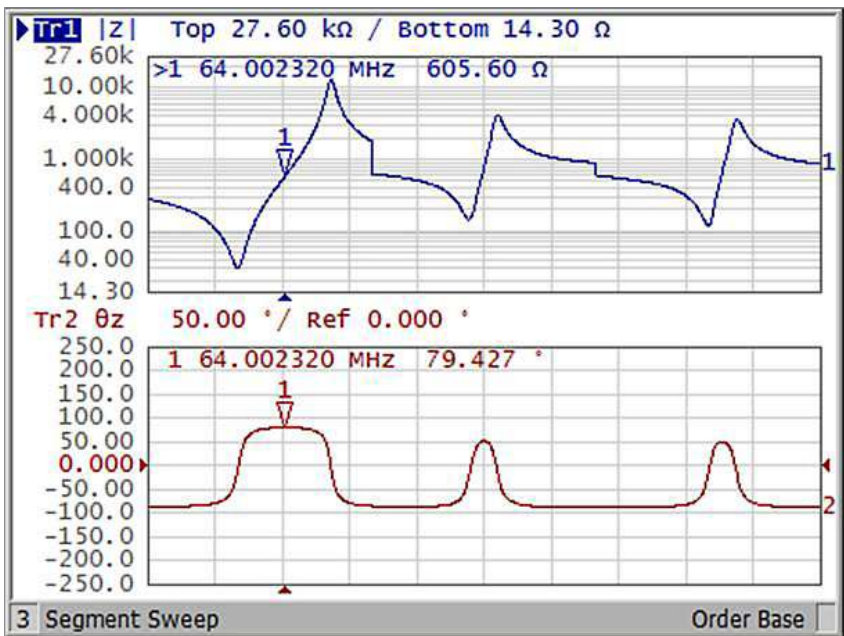

Crystal resonator evaluation by segment sweep (64 MHz crystal, OSC level = 500 mV)

## Equivalent Circuit Analysis

The purpose of equivalent circuit analysis is to model the impedance versus frequency characteristics with three or four elements.

Seven different multi-parameter models accommodate different types of devices such as capacitors, inductors or resonators. You can simulate the impedance trace of your own equivalent circuit parameter values and then compare it with an actual measurement trace. The equivalent circuit parameters can also be saved as a text file.

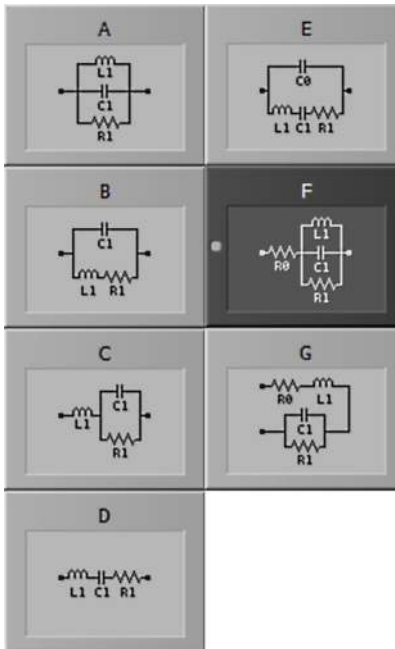

Seven selectable equivalent circuit models

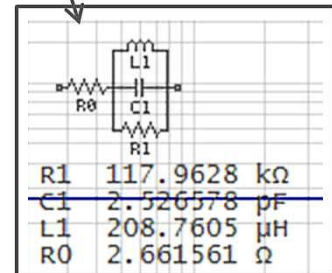
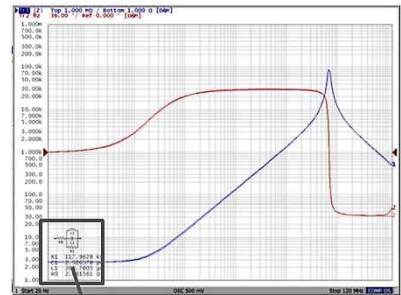

Equivalent parameters for a low inductor (F circuit is used)

## Unparalleled Accuracy

The E4990A offers the highest level of impedance measurement accuracy and repeatability over a wide impedance/frequency range up to 120 MHz.

- 0.08% (0.045%, typical) basic impedance measurement accuracy
- 25 mΩ to 40 MΩ impedance measurement range (10% measurement accuracy range)
- Small trace noise

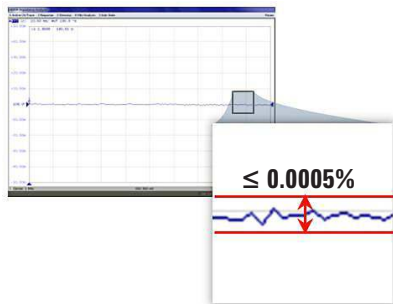

$\leq 0.0005\%$  trace noise for accurate and repeatable measurements ( $\leq 0.0005 \Omega$ , 100  $\Omega$  at 1 MHz, measurement time = 5, 1 sigma with 200 times measurement)

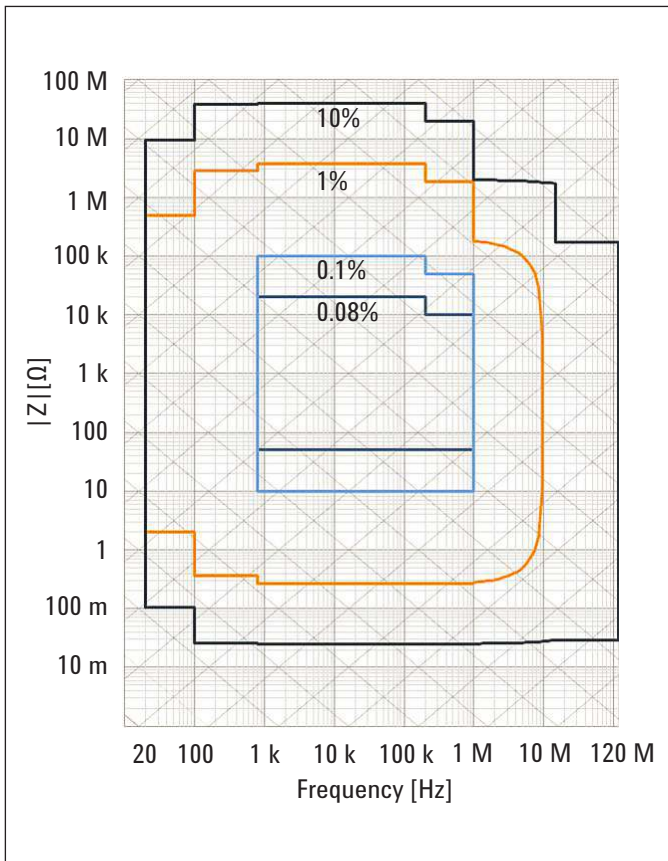

10% impedance measurement accuracy range at Four-terminal-pair of E4990A's Front Panel (Test signal level = 0.5 Vrms, measurement Time = 5)

## Benefits of Keysight Accessories

Keysight offers a variety of accessories suitable for many applications. They are designed to make measurements simple and reliable. Each accessory is designed to ensure highly accurate measurements without degrading the performance of the measurement instrument.

- 42941A Impedance probe kit, convert four-terminal-pair port to a one-port probe (Option 120 only)
- 42942A Terminal adapter, convert four-terminal-pair port to a 7-mm port (Option 120 only)
- 16048G/H Four-terminal-pair test leads, extend the four-terminal-pair port



E4990A with 42942A terminal adapter



# Choose Your Test Fixture

**16047A (DC to 13 MHz)**  
For leaded.

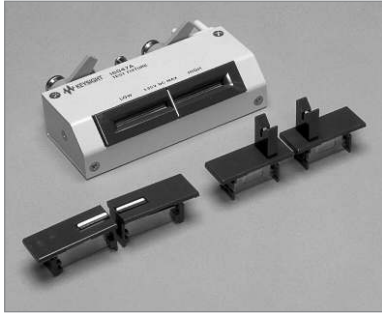

**16047E (DC to 120 MHz)**  
For leaded.

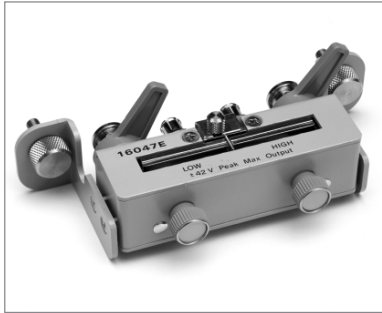

**16034G (DC to 120 MHz)**  
For side electrode SMD.  
0603 (mm)/0201(inch) to  
3216(mm)/1206(inch) size.



**16044A (DC to 10 MHz)**  
For side electrode SMD.  
1608 (mm)/0603 (inch) or larger size.



**16092A (DC to 500 MHz)**  
For leaded or SMD.  
The 42942A adapter is required.



**16192A (DC to 2 GHz)**  
For side electrode SMD.  
1608 (mm)/0603 (inch) or larger size.  
The 42942A adapter is required.

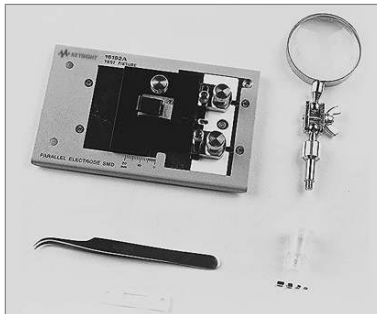

**16196A/B/C/D (DC to 3 GHz)**  
Coaxial fixture specialized for the  
following SMD sizes:  
16196A: 1608 (mm)/0603 (inch)  
16196B: 1005 (mm)/0402 (inch)  
16196C: 0603 (mm)/0201 (inch)  
16196D: 0402 (mm)/01005 (inch)  
The 42942A adapter is required.



**16197A (DC to 3 GHz)**  
For bottom electrode SMD.  
0603 (mm)/0201(inch) to 3225  
(mm)/1210 (inch).  
The 42942A adapter is required.

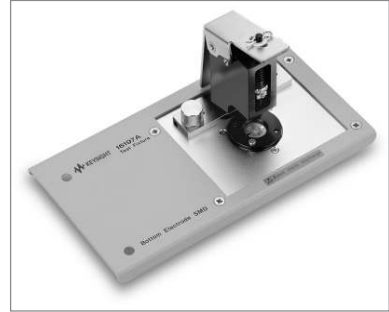

**16451B (DC to 30 MHz)**  
For dielectric material.



**16452A (20 Hz to 30 MHz)**  
For liquid material.

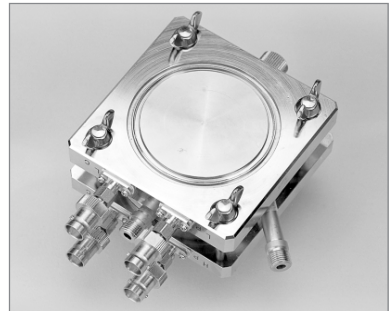

**16454A (1 kHz to 1 GHz)**  
For toroidal magnetic material.  
The 42942A adaptor is required.



## Migrating from 4294A to E4990A

The E4990A includes all the functionality of the industry-standard 4294A impedance analyzer while exceeding the performance and providing more powerful functions, intuitive user interface and PC connectivity. Five frequency options (20 Hz to 10/20/30/50/120 MHz) and frequency upgrades allow you to choose the most appropriate frequency option with the least amount of investment.

### Key specifications and function comparison

	<b>E4990A</b>	<b>4294A</b>
Frequency	20 Hz to 10/20/30/50/120 MHz, five frequency options are available	40 Hz to 110 MHz
Measurement parameters	Z ,  Y , $\theta$ , R, X, G, B, L, C, D, Q, Complex Z, Complex Y, Vac, Iac, Vdc, Idc	Z ,  Y , $\theta$ , R, X, G, B, L, C, D, Q, Complex Z, Complex Y
Basic accuracy	$\pm 0.08\%$ (typical $\pm 0.045\%$ )	$\pm 0.08\%$
Z measurement range	25 m $\Omega$ to 40 M $\Omega$ ( $\pm 10\%$ measurement accuracy)	25 m $\Omega$ to 40 M $\Omega$ ( $\pm 10\%$ measurement accuracy)
Signal level	5 mVrms to 1 Vrms/200 $\mu$ Arms to 20 mArms	5 mVrms to 1 Vrms/200 $\mu$ Arms to 20 mArms
DC Bias	0 to $\pm 40$ V/100 mA, 1 mV/40 $\mu$ A resolution	0 to $\pm 40$ V/100 mA, 1 mV/40 $\mu$ A resolution
Auto Level Control (ALC)	Signal level (V/I), DC bias (V/I)	DC bias (V/I)
Measurement Time ( $\geq 100$ kHz)	3 ms/point at 1 fast (Option 120) 30 ms/point at 1 fast (Options 010/020/030/050)	3 ms/point at BW = 1
Number of points	2 to 1601	2 to 801
Trace noise example (100 $\Omega$ at 1 MHz, 1 sigma with 200 times measurement)	$< 0.002 \Omega$ (0.002%) at measurement time = 1	$< 0.02 \Omega$ (0.02%) at measurement time = 1
Channels/traces	4-channel/4-trace	1-channel/2-trace
Display (type, resolution)	10.4 inch TFT color LCD with touch screen, XGA (1024 x 768)	8.4 inch TFT color LCD, VGA (640 x 480)
Data storage	SSD (built-in), external devices connected via USB ports	Non-volatile memory (built-in), 1.44 MB FDD
Interface	USB (front 2, rear 4), GPIB, LAN, 24 Bit I/O, USBTMC	GPIB, LAN, 24 Bit I/O
Control commands	E4990A unique SCPI	4294A unique
Size (mm), Weight	425 (W) x 235 (H) x 277 (D), 14 kg	425 (W) x 235 (H) x 445 (D), 25 kg

## Ordering Information

### E4990A Impedance analyzer

- 100  $\Omega$  load resistor for four-terminal-pair extension
- Power cord
- Installation guide
- CD-ROM IO libraries

Model-Option	Description
E4990A-010	20 Hz to 10 MHz
E4990A-020	20 Hz to 20 MHz
E4990A-030	20 Hz to 30 MHz
E4990A-050	20 Hz to 50 MHz
E4990A-120	20 Hz to 120 MHz

### Other Options

E4990A-1E5	High stability
E4990A-810	Add keyboard
E4990A-820	Add mouse
E4990A-1CM	Rack mount kit
E4990A-1CN	Front handle kit
E4990A-1CP	Rack mount and front handle kit
E4990A-1A7	ISO 17025 compliant calibration
E4990A-A6J	ANSI Z540 compliant calibration

### Model-Option Description

#### E4990AU upgrade kits

E4990AU-020	Upgrade from 10 MHz to 20 MHz
E4990AU-030	Upgrade from 10 MHz to 30 MHz
E4990AU-050	Upgrade from 10 MHz to 50 MHz
E4990AU-120	Upgrade from 10 MHz to 120 MHz
E4990AU-031	Upgrade from 20 MHz to 30 MHz
E4990AU-051	Upgrade from 20 MHz to 50 MHz
E4990AU-121	Upgrade from 20 MHz to 120 MHz
E4990AU-052	Upgrade from 30 MHz to 50 MHz
E4990AU-122	Upgrade from 30 MHz to 120 MHz
E4990AU-123	Upgrade from 50 MHz to 120 MHz
E4990AU-1E5	High stability timebase

## Accessories

### 42941A impedance probe kit

Convert four-terminal-pair port configuration to a one-port probe. To use this kit, frequency Option E4990A-120 is required.



### 42942A terminal adapter

Convert four-terminal-pair port configuration to an 7 mm port. To use this adapter, frequency Option E4990A-120 is required.

Option: 42942A-700

Add 7 mm open/short/load set



### Four-terminal-pair test leads

16048G/16048H

1 m/2 m four-terminal-pair port extension cable with BNC connectors.

Cable length:

1 m (16048G)

2 m (16048H)

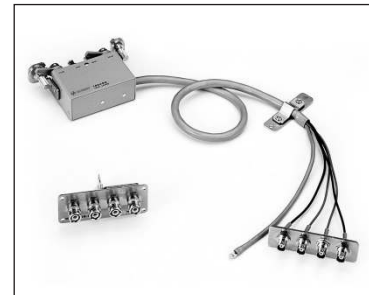

## Additional Information

### Websites

Have access to the following website to acquire the latest news, product and support information, application literature and more.

[www.keysight.com/find/impedance](http://www.keysight.com/find/impedance)

[www.keysight.com/find/e4990a](http://www.keysight.com/find/e4990a)

### Literature

*E4990A*, Data Sheet, 5991-3890EN

*E4990A*, Configuration Guide, 5991-3891EN

*LCR Meters, Impedance Analyzers and Test Fixtures*, Selection Guide, 5952-1430E

*Accessories Selection Guide for Impedance Measurements*, 5965-4792E

*Impedance Measurement Handbook*, 5950-3000

For more information on Keysight Technologies' products, applications or services, please contact your local Keysight office. The complete list is available at: [www.keysight.com/find/contactus](http://www.keysight.com/find/contactus)

#### Americas

Canada	(877) 894 4414
Brazil	55 11 3351 7010
Mexico	001 800 254 2440
United States	(800) 829 4444

#### Asia Pacific

Australia	1 800 629 485
China	800 810 0189
Hong Kong	800 938 693
India	1 800 112 929
Japan	0120 (421) 345
Korea	080 769 0800
Malaysia	1 800 888 848
Singapore	1 800 375 8100
Taiwan	0800 047 866
Other AP Countries	(65) 6375 8100

#### Europe & Middle East

Austria	0800 001122
Belgium	0800 58580
Finland	0800 523252
France	0805 980333
Germany	0800 6270999
Ireland	1800 832700
Israel	1 809 343051
Italy	800 599100
Luxembourg	+32 800 58580
Netherlands	0800 0233200
Russia	8800 5009286
Spain	0800 000154
Sweden	0200 882255
Switzerland	0800 805353
	Opt. 1 (DE)
	Opt. 2 (FR)
	Opt. 3 (IT)
United Kingdom	0800 0260637

For other unlisted countries:  
[www.keysight.com/find/contactus](http://www.keysight.com/find/contactus)  
 (BP-07-10-14)

**myKeysight**

myKeysight

[www.keysight.com/find/mykeysight](http://www.keysight.com/find/mykeysight)

A personalized view into the information most relevant to you.

**Three-Year Warranty**

[www.keysight.com/find/ThreeYearWarranty](http://www.keysight.com/find/ThreeYearWarranty)

Keysight's commitment to superior product quality and lower total cost of ownership. The only test and measurement company with three-year warranty standard on all instruments, worldwide.

[www.keysight.com/go/quality](http://www.keysight.com/go/quality)

Keysight Technologies, Inc.

DEKRA Certified ISO 9001:2008

Quality Management System

**Keysight Channel Partners**

[www.keysight.com/find/channelpartners](http://www.keysight.com/find/channelpartners)

Get the best of both worlds: Keysight's measurement expertise and product breadth, combined with channel partner convenience.

