

# Keysight Technologies

## B1506A Power Device Analyzer for Circuit Design



## The B1506A eliminates power device performance uncertainties for circuit designers

Do you have confidence that your circuit will function correctly in mission critical applications?

Do you worry about having to recall thousands of products because you used faulty devices in your circuits?

The B1506A provides you with power device data under real operating conditions to ensure sufficient circuit operating margins.

Even with no test experience, the B1506A allows you to measure IV and CV across temperature and identify counterfeit and out-of-spec devices.



### Features

- Measures all IV parameters ( $R_{on}$ , BV, Leakage,  $V_{th}$ ,  $V_{sat}$ , etc.)
- Measures transistor input, output and reverse transfer capacitances at high voltage biases
- Measures gate charge (Qg)
- Performs power loss (conduction, driving and switching evaluation)
- Easy to use and fully automated operation
- Wide current and voltage operating range (1500A, 3kV)
- Thermal test capability (  $-50^{\circ}\text{C}$  to  $+250^{\circ}\text{C}$ )
- Oscilloscope View supports visual verification of pulsed measurement waveforms on the front panel

### Benefits

- Optimize circuit performance thru correct power device selection
- Sufficient yet efficient circuit operating margin
- Small form factor
- Low power loss
- Higher reliability thru screening of potentially faulty devices
- Lower product cost
- Maximize productivity via fast development cycles
- Reduced prototype development cycles
- Fast and effective device selection
- Quick device trouble shooting

# Complete power device characterization to guarantee that your circuits work the first time

## Automatically obtain the key parameters necessary for robust circuit operation across a wide operating range

If you are a circuit designer using power devices in your products, then you know how important it is to have an accurate and thorough understanding of the performance of those devices over a wide range of conditions. Power devices ultimately determine the power loss in an electronic circuit, so a deep understanding of their characteristics is critical to the development of reliable and energy efficient products. Unfortunately, the typical power device data sheet only shows behavior across a limited range of operating conditions. In addition, the test methodologies necessary to obtain key datasheet parameters are not always straightforward, and measuring device parameters on curve tracers and other traditional equipment can be tedious and time consuming. The growing use of wide bandgap devices, especially those fabricated using SiC or GaN, has also introduced additional test complexity for parameters such as on-resistance, capacitance and breakdown voltage that require new measurement solutions.

The Keysight B1506A meets a vital need by providing an automated and easy-to-use means to extract power device parameters. It can measure all of the parameters shown in the table on the right, and its intuitive GUI makes it easy for even a novice user to extract critical device parameters across a wide range of current, voltage and temperature conditions.

## Verify temperature performance to ensure operation in harsh environments

Power devices are used in a wide range of products, including heavy equipment, high speed railways and automobiles. For obvious reasons, all of these products need to be extremely reliable, and they need to operate under harsh environmental conditions. Thermal performance is of particular importance, since device operation at both low temperatures (for “cold” automotive start) and high temperatures (for devices located near heat emitting equipment) must be guaranteed. In addition to understanding general device characteristics over temperature, it may also be necessary to screen devices across temperature since devices that look fine at room temperature can sometimes be out of spec at low or high temperature. Unfortunately, temperature characterization of power devices is not easy. Thermal test chambers can take a long time for their temperature to stabilize, and long cables leading from the chamber to the test equipment can create resistive and inductive oscillation problems.

The B1506A meets all of these power device temperature testing challenges. It supports industry-standard inTest Thermostream temperature control systems, allowing the B1506A to accurately and automatically characterize devices from -50° C to 220° C. Moreover, if only high temperature characterization is required then an optional thermal plate is available that supports temperature

measurements from room up to 250° C. Both of these solutions allow temperature measurements to be made in the B1506A's test fixture, eliminating lengthy cables and minimizing the risk of oscillation. Both of these solutions also take into account condensation and user safety issues. The B1506A simplifies the previously arduous task of power device temperature characterization, enabling you to focus on your primary goal of ensuring that your products meet all of their temperature performance requirements.

*The B1506A can measure all of these device parameters.*

Category	Parameters
Threshold voltage	V(th), Vge(th)
Transfer Characteristics	Id-Vgs, Ic-Vge, gfs
On resistance	Rds-on, Vce(sat)
Gate leakage current	Igss, Iges
Output leakage current	Idss, Ices
Output Characteristics	Id-Vds, Ic-Vce
Breakdown voltage	BVds, BVces
Gate Charge	Qg, Qg(th), Qgs, Qgd, Qsw, Qsync, Qoss
Gate Resistance	Rg
Device Capacitance	Ciss, Coss, Crss, Cgs, Cgd, Cies, Coes, Cres
Switching loss	Driving loss/Switching loss at a specified frequency Conduction loss at a specified duty cycle

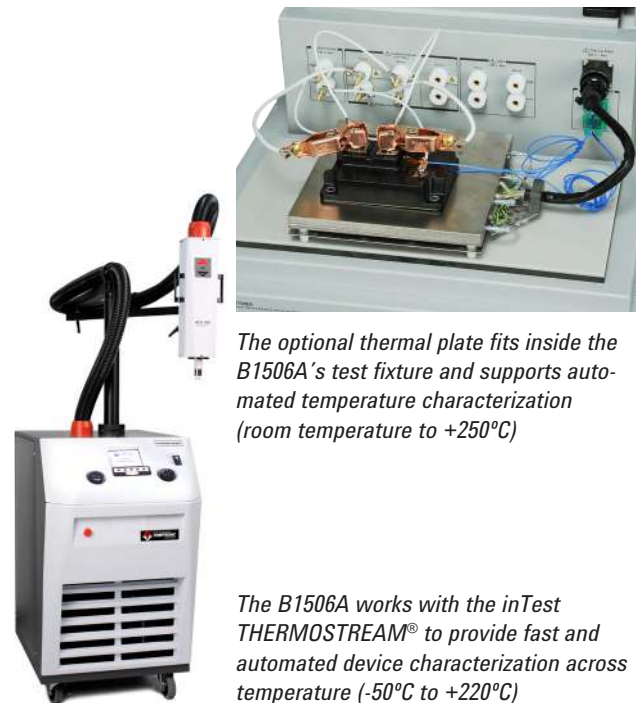

*The optional thermal plate fits inside the B1506A's test fixture and supports automated temperature characterization (room temperature to +250°C)*

*The B1506A works with the inTest THERMOSTREAM® to provide fast and automated device characterization across temperature (-50°C to +220°C)*

# Wide measurement range, flexible SMU technology and traceability to standards ensure first time design success

## The B1506A's wide current and voltage measurement ranges meet advanced power electronics needs

Certain power electronics circuits are designed to handle large currents (such as those necessary for driving motors or energizing an LED), and in the case of heavy equipment the current requirements can easily be 1000 A or more. Although in these applications no current is supposed to flow in the off-state, typically there are some small leakage currents under conditions of high voltage bias. This means that even sub-nanoamp current measurements on the power devices used in these applications may be necessary to guarantee the energy efficiency of the end products. Understanding the maximum current when a device is on and the leakage current when a device is off is important for circuit designers, since these characteristics impact both operating margin and energy efficiency. The B1506A can easily meet these measurement requirements. With the ability to measure currents from picoamps up to 1500 A and voltages from microvolts up to 3 kV, the B1506A is an all-in-one solution for designers of high current and high voltage circuitry.

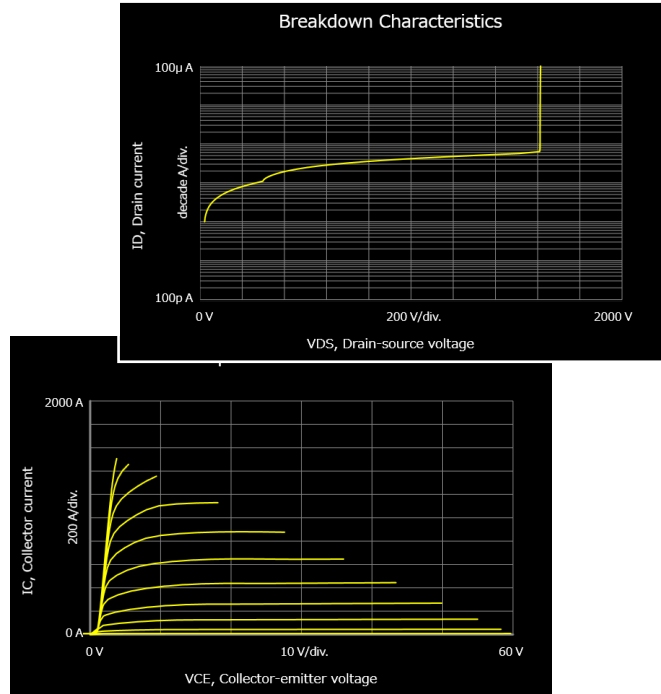

## SMUs facilitate component characterization under actual circuit bias conditions

Depending on device type and how it is being used in the circuit, a power device may be voltage controlled or current controlled. Obviously, when evaluating how a device will perform in a circuit it is important to drive it using the same stimulus it will experience in the circuit. In addition, certain device parameters are best evaluated in a forced current or forced voltage mode. For example, power device on resistance should be evaluated by forcing a current through the device that matches the current at which the on resistance is specified. Also, in many cases a power device datasheet does not specify device behavior under actual use conditions, so some means to characterize it under a specific voltage or current bias is extremely valuable.

Unlike traditional curve tracers, the B1506A utilizes advanced SMU (Source Monitor Unit) technology. An SMU can function as either a precision voltage source or a precision current source, and it can also simultaneously and accurately measure both voltage and current. In addition, a simple software command allows you to toggle the internal SMU operation between current source mode and voltage source mode without requiring any physical connection changes. SMUs also have feedback circuitry that monitors the sense terminal and quickly corrects the voltage and current applied to the DUT to match its programmed value. SMU technology makes it easy to characterize power devices under the exact same bias conditions as they will experience in a power electronics circuit.

Measure ultra-high current characteristics up to 1500 A and accurate blocking characteristics up to 3 kV

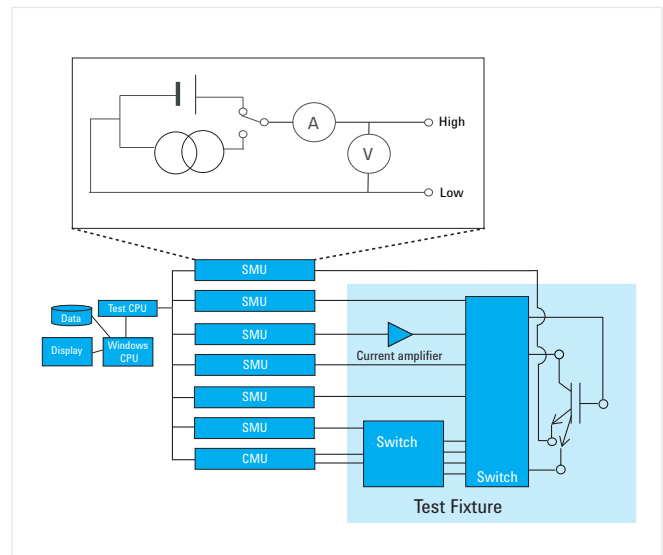

B1506A hardware architecture utilizes advanced SMU technology

## Wide measurement range, flexible SMU technology and traceability to standards ensure first time design success

### Traceability to international standards guarantees measurement accuracy

For all levels of current and voltage, it is important to obtain accurate and reliable measurement results. The larger the measurement error is in device evaluation, the larger the negative impact it has on circuit operating margins and peripheral circuit design. However, test data taken using traditional power device measurement equipment (such as curve tracers) is suspect in terms of measurement accuracy and reliability. Therefore, many circuit designers only use curve tracers to verify gross device functionality, and take the numerical measurement results as only a rough indication of device behavior. Obviously, when the need arises to compare the characteristics of multiple devices or to verify a device meets a manufacturer's specifications, having only approximate device characterization data is not acceptable.

Keysight Technologies has developed a measurement standard for currents greater than 1000 A, making Keysight one of the few companies capable of providing ultra-high current testing with traceability to international standards. In addition, voltage measurements of up to 3 kV have this same traceability, as of course also do smaller current and voltage measurements. All B1506A instruments come with a Certificate of Calibration (COC) that guarantees their ability to make reliable measurements.

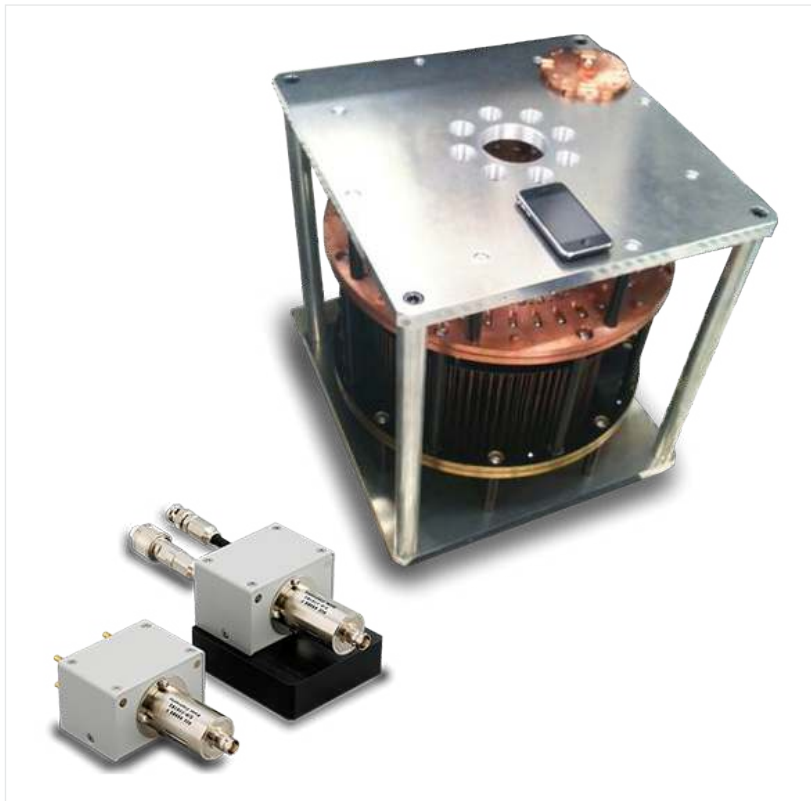

*Internationally traceable measurement standard ensures test confidence*

# Accurately estimate device power loss in your power circuits before fabrication

## Measure gate charge (Qg) parameters under actual use conditions

The rapid acceleration of power device performance continues to drive switching power supply operation frequencies higher and end product sizes smaller. Novel new device types and materials, such as super junction MOSFETs and SiC and GaN FETs, offer superior switching performance and realize unprecedented frequency operating ranges (from several hundred kHz to over 1 MHz). Higher switching frequencies drive down power circuit costs by reducing the size of the circuit's magnetic components, which makes the entire power circuit lighter. However, higher switching frequencies increase a power device's switching and driving losses, making it critical to select power devices that minimize these parameters.

Gate charge (Qg), which is defined as the total amount of charge necessary to drive a power device, is an extremely important parameter when estimating the driving loss during circuit operation. The driving loss consists of the product of Qg, the gate voltage (Vg), and the switching frequency. Accurate Qg evaluation allows precise driving loss calculation as well as optimized design of the driving circuit.

Qg also provides other useful information to help with switching operation analysis. For example, when a circuit is not meeting performance expectations, examining the Qg curve can offer valuable insights that help determine the root cause of the issue.

Since Qg varies with the output voltage and current, it should be evaluated under in-circuit bias conditions. The Qg characteristics shown on a device datasheet only provide an approximation of the value of Qg during actual circuit operation.

The B1506A can accurately evaluate Qg for both low voltage and high voltage power devices. The B1506A can not only produce the complete gate charge curve, but also many other gate charge related parameters.

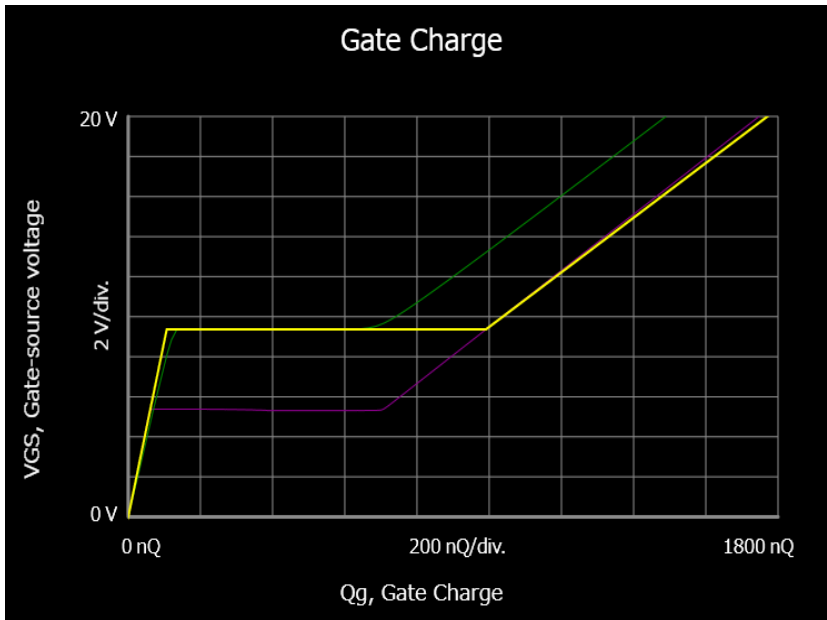

Gate charge characteristics for a super junction MOSFET



# Accurately estimate device power loss in your power circuits before fabrication

## Quick and easy power loss calculation

In addition to driving loss, the B1506A can also calculate conduction loss and switching loss. While gate charge is defined as the total amount of charge required to turn on a FET, the Qg curve can also be interpreted as a representation of the non-linearity of a power device's stray capacitances. This makes it possible to calculate switching parameters and switching loss using known equations that combine the gate resistance, the resistance in series to the gate, and the switching frequency. The B1506A's ability to accurately measure on-resistance (Ron) and peak current also make it easy to calculate conduction loss.

The B1506A's software has a unique user interface optimized for circuit designers. It supports simple and easy evaluation of a device's IV and Qg characteristics, and it also has the ability to display a device's driving, switching and conduction losses on the B1506A's screen.

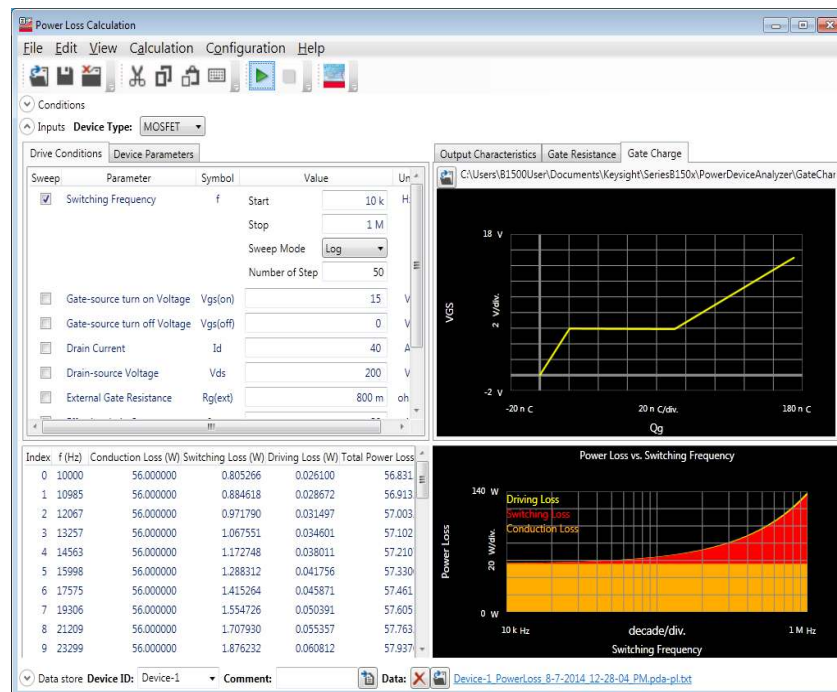

Driving, conduction and switching losses calculated by the B1506A

Measure all parameters required for power circuit design under actual operating conditions

## All parameters

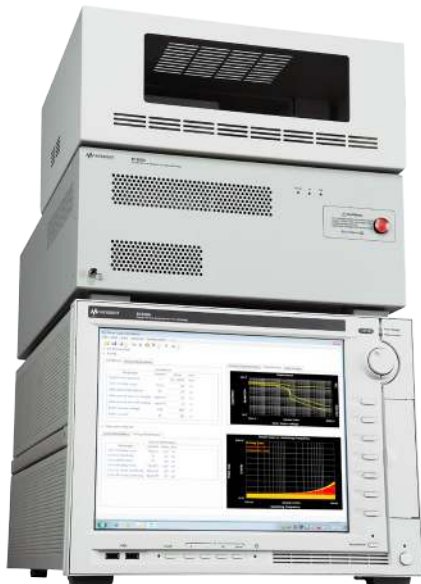
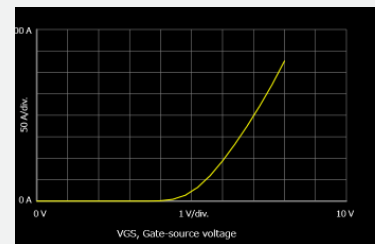
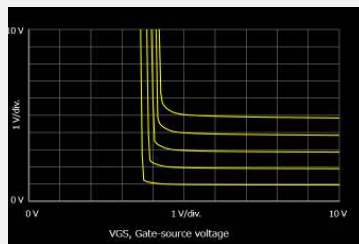
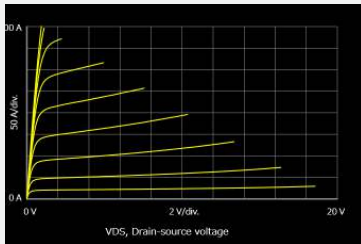
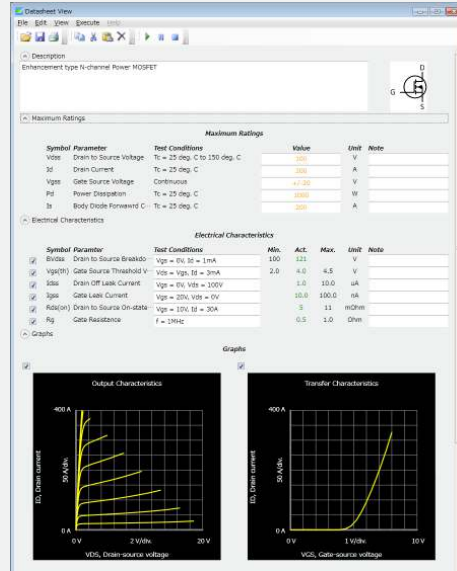
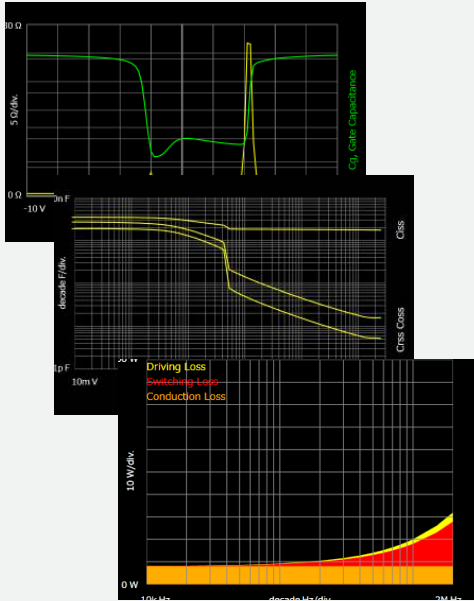



Measure all parameters required for power circuit design under actual operating conditions

Wide range of operating conditions

- 1500 A
- 3 kV
- -50 °C to +250 °C



Select the ideal power device

Optimize product performance through

- Smaller form factor
- Improved reliability
- Reduced cost
- Higher energy efficiency

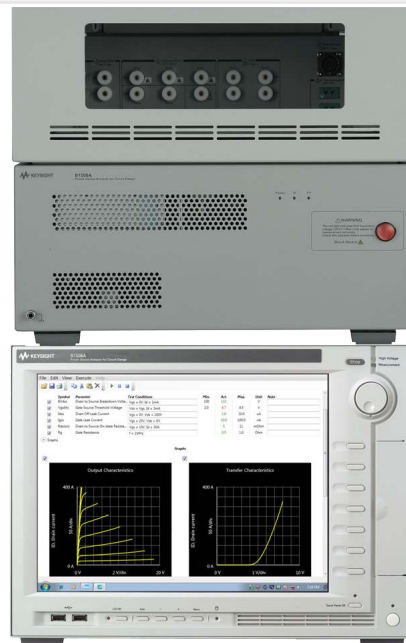
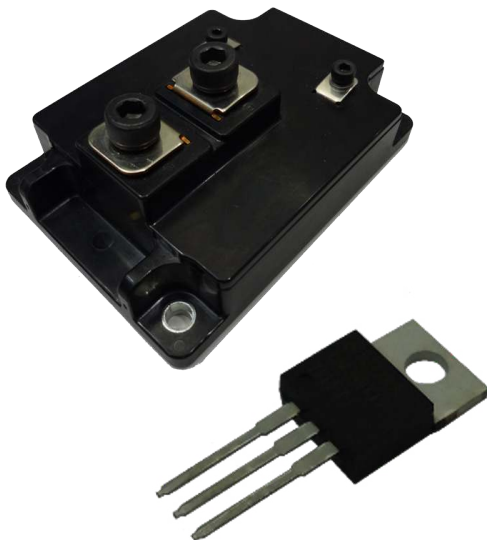
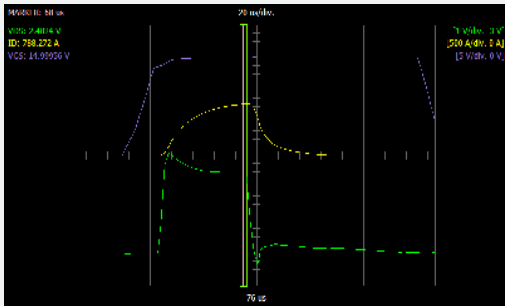

## Easy and elegant switching loss analysis

### Fully automated input, output and reverse transfer capacitance measurement

Understanding the input, output and reverse return capacitances of three terminal devices (such as MOSFETs or IGBTs) is very important, because these parameters dictate the switching speed and the switching loss when a switching power supply operates at high frequency. However, accurately measuring these parameters is not easy or straightforward. When measuring the capacitance between two terminals of a three terminal device, the other terminal needs to be appropriately configured (using the capacitance meter's AC guard output) in order to make an accurate measurement. Depending upon the capacitance parameter and type of device being measured, other components (such as an AC blocking resistor or a DC blocking capacitor) may also be needed. In addition, some capacitance measurements need high voltage biases to be applied to the DUT, requiring additional components to protect instrument resources from damage in the event of device breakdown. For all of these reasons, a great deal of skill and thought needs to go into making a single type of capacitance measurement, and it is easy to make a mistake that leads to invalid data collection.

The B1506A can automatically and accurately measure FET capacitance values ( $C_{iss}$ ,  $C_{oss}$ ,  $C_{rss}$ ) using its built-in capacitance selector module. The capacitance selector contains all of the resistors, capacitors and protection circuits necessary to make high-voltage capacitance measurements, and it automatically arranges these components into the correct configuration for a specified capacitance measurement. The B1506A's capacitance selector can even provide accurate capacitance data for normally on devices (such as SiC JFETs).

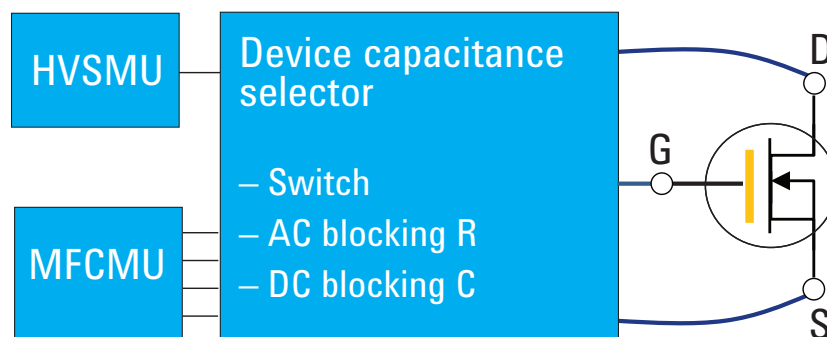

*Capacitance selector supports fully automated  $C_{iss}$ ,  $C_{oss}$  and  $C_{rss}$  measurement*

# Easy and elegant switching loss analysis

## Measure device junction capacitances at DC biases of up to 3kV

An applied DC voltage causes a power device's depletion region to modulate, which in-turn causes the junction capacitance to vary with voltage. The drain or collector terminal of a power device is often exposed to high voltages when it is off, which determines the value of its junction capacitances at the moment it turns on. Therefore, understanding how device capacitance changes with applied voltage is very important for power electronics circuit designers. Knowing the true value of device capacitance at a specific voltage and the calculated voltage the device will experience in a circuit allows you to select a power device with the lowest loss. The B1506A automates the process of determining the drain and collector voltage dependency of the input, output, and reverse transfer capacitances. Moreover, although power device capacitance measurement needs to be performed at relatively high frequencies, the B1506A has the ability to compensate for the various parasitic elements in the cables and fixturing and to produce reliable capacitance measurements.

The B1506A can also automatically calculate the device gate resistance ( $R_g$ ) when it performs capacitance measurement, eliminating the need for additional complicated data analysis. Gate resistance is an important parameter for circuit designers, since it influences device operation speed and switching loss.

## More precise switching waveform simulations

For power electronics circuit designers, circuit simulators such as SPICE are an essential tool. Accurately simulating the performance of a circuit can result in significant cost savings through reduced development cycles and prototyping. However, until now accurate modeling of non-linear capacitance characteristics was not possible since no equipment existed that could perform high voltage capacitance measurements. The B1506A has the ability to precisely model  $C_{rss}$ ,  $C_{iss}$  and  $R_g$ , which is essential for accurate power circuit simulations. The B1506A can generate accurate values for these parameters because it can correlate  $C_{rss}$  and  $C_{iss}$  voltage dependency with the devices' gate charge characteristics. The switching characteristics on the right show simulation results obtained using precise  $C_{rss}$ ,  $C_{iss}$  and  $R_g$  modeling data.

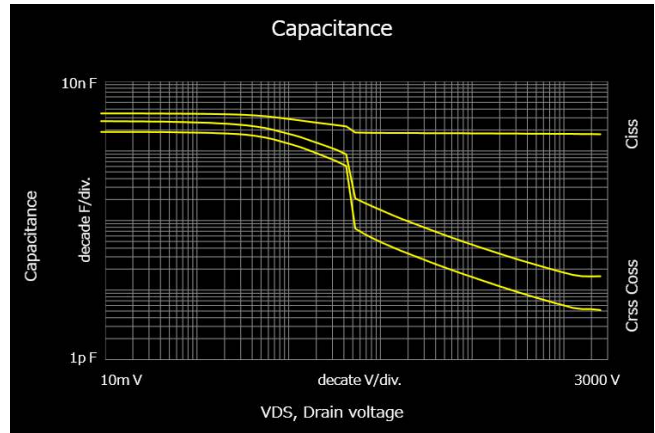

*$C_{iss}$ ,  $C_{oss}$  and  $C_{rss}$  vs. drain voltage.*

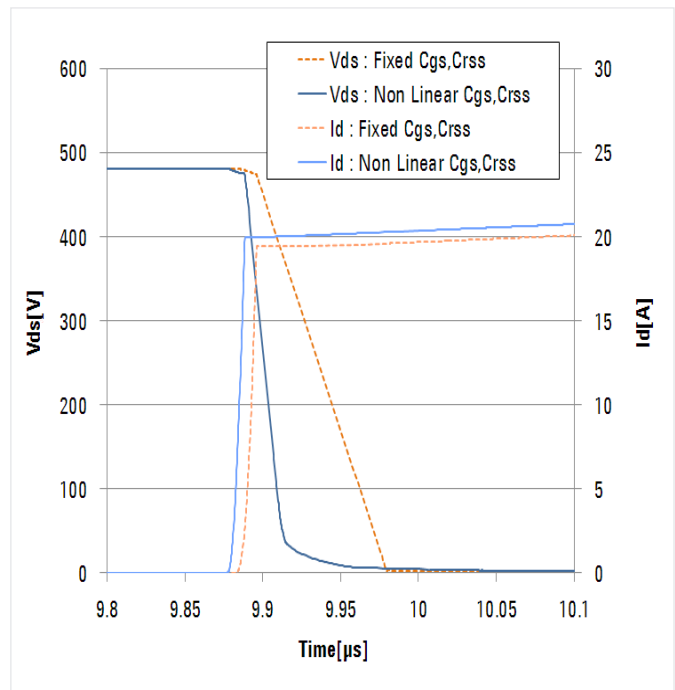

*Simulation example: Switching waveforms with & without CV and  $R_g$  data*

## Eliminate concerns about using counterfeit or substandard power devices in your circuits

The B1506A can measure the key parameters essential to insure reliable and efficient device performance

The traditional method to select devices to use in a power electronics circuit involves checking device data sheet characteristics or measuring gross characteristics using a curve tracer. Unfortunately, you can never be certain that a power device's behavior matches the characteristics shown on its device datasheet, and curve tracers can only provide coarse parameters such as breakdown voltage and approximate on-resistance. Modern high-performance power devices exceed the measurement capabilities of traditional curve tracers, and of course curve tracers cannot characterize capacitance at all. Understanding the relationship between on-resistance and gate-to-drain capacitance ( $C_{gd}$ ) is also crucial to optimize high-speed device performance. If you reduce device on-resistance by reducing channel width then capacitances such as  $C_{gd}$  will increase. This means that both on-resistance and capacitance have to be measured in order to accurately predict device performance. In fact, low-cost, low-performance devices and counterfeit devices often have large junction capacitances even though their measured on-resistance is low. In addition to capacitance and on-resistance issues, inferior grade devices also often show severe performance degradation at high temperatures.

The B1506A can easily characterize the three key parameters of on-resistance, junction capacitance and temperature dependency. This makes it easy to detect counterfeit and inferior power devices, which offers many obvious cost benefits in terms of reducing design cycles and product liability issues.

## Efficient fault isolation

When circuits do not perform as expected, a very effective troubleshooting method is to perform a detailed characterization of each power device in the circuit. Many times incorrect circuit operation is due to unforeseen leakage currents or degraded breakdown voltages. Recognizing a bad component can often provide a shortcut to identifying a solution for improper circuit behavior.

The B1506A's easy-to-use and intuitive GUI makes it easy to verify the behavior of a power device. The B1506A has a Pass/Fail mode that collates test results with predefined limits and highlights the failed parameters in red.

If further detailed characterization is necessary, then the well-proven EasyEXPERT software interface is available to create more specific measurement setups. In addition, an Oscilloscope View is available that allows you to monitor in the time domain the actual pulsed voltage and current waveforms being applied to the DUT at any point along a measurement curve. These B1506A features can significantly expedite the process of fault isolation.

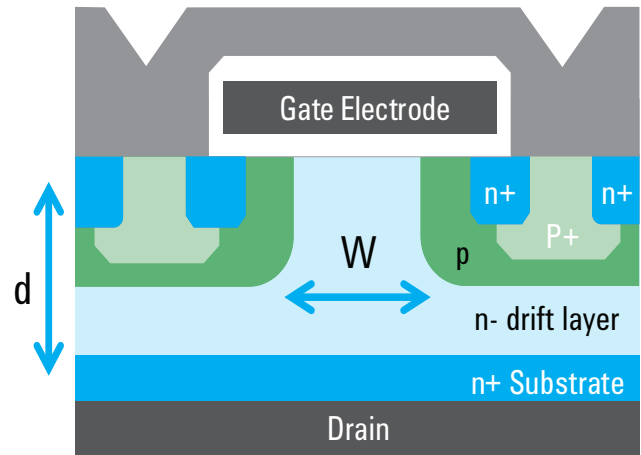

Trade-off between on-resistance and device capacitance

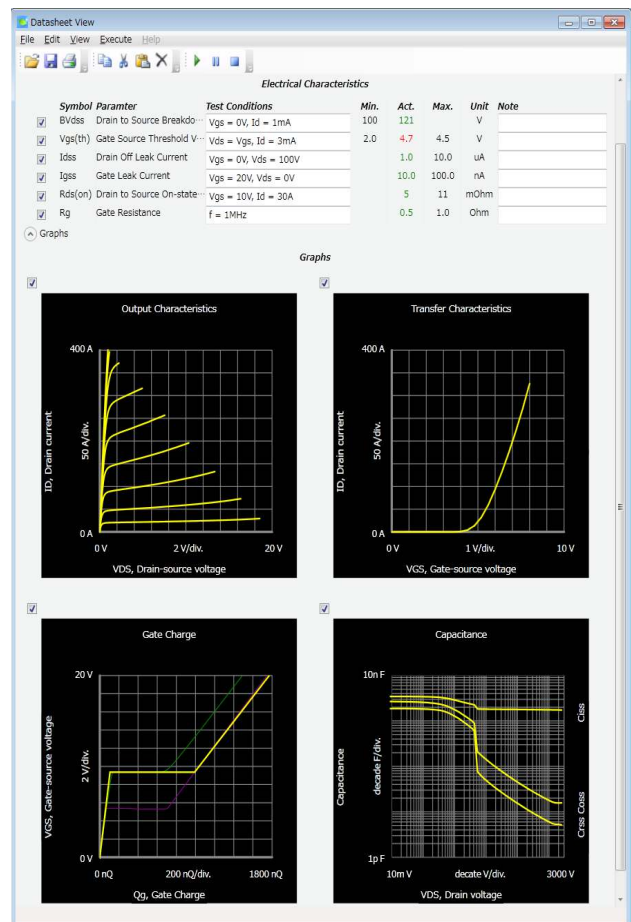

The B1506A software is useful to check power device behavior

# Achieve accurate results immediately without the need for training or measurement expertise

## Intuitive data sheet style user interface and simple cable connections eliminate need for product training

Traditional power device evaluation has been a complicated process involving many different pieces of equipment (curve tracers, oscilloscopes, LCR meters, production functional testers, etc.). Not only does it take a long time to learn how to use this equipment properly, but a lack of automation capability means that it is easy to make mistakes that can cast doubt on the measurement results. However, the B1506A has a unique data sheet characterization mode that displays device tests in data sheet format. It provides an intuitive interface that enables anyone to measure key device parameters without any specialized training. In addition, all device characteristics (including high current, high voltage, small leakage currents and three terminal device capacitances) can be measured without any need to modify the device connections. Since typical test setups for common devices such as MOSFET and IGBTs are built-in, you can start characterizing devices immediately after unpacking the B1506A. Of course, it is also easy to customize the predefined setups. All measurement results are automatically stored onto the B1506A's internal hard disk drive, making it easy to generate test reports later. To facilitate the detection of counterfeit and substandard devices quickly, a Pass/Fail feature is also available.

The B1506A's cabling connections and DUT connections inside the test fixture are also easy to make, and the B1506A's simplified interface architecture greatly minimizes the chance of operator error. From both a hardware and software perspective, the B1506A is the best instrument to perform power device characterization.

## Innovative switching technology supports a fully automated IV and CV measurement solution

Although understanding both the IV and CV characteristics of power devices has become more important than ever as switching frequencies have increased, no equipment has been available that could evaluate both of these parameters. There are several reasons for this, all relating to the CV measurements. The first is simply that high voltage bias CV measurements are innately difficult to make. The second is that the circuit complexities involved in switching between IV and CV measurements are not trivial, since some capacitance measurements require additional AC or DC blocking components. The third and final issue is that CV measurements require proper compensation to cancel out measurement error, which typically requires some measurement expertise on the part of the user. In addition to these challenges, automating this entire process is not a trivial task.

However, Keysight's unmatched semiconductor device capacitance measurement expertise, combined with an innovative switching solution, allows the B1506A to make fully compensated and automatic IV and CV measurements at the touch of a button.



The intuitive data sheet characterization mode provides complete device characteristics in a few simple steps



Simplified DUT connections eliminate errors

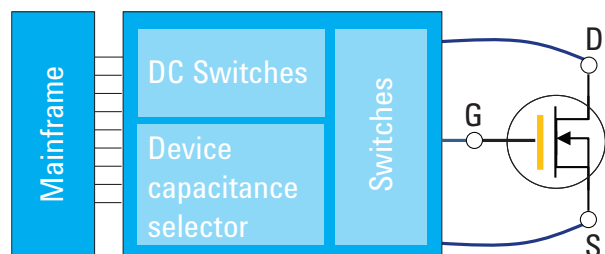

Innovative switching solution supports fully automated IV and CV measurements

## Selection guide

Key Specification				B1506A-H21	B1506A-H51	B1506A-H71
Collector/ Drain channel	Max output	Voltage		±3000 V	±3000 V	±3000 V
		Current	DC	±1 A	±100 mA	±100 mA
			Pulsed	±20 A	±500 A	±1500 A
Source	Min. resolution	Voltage		25 µV	25 µV	25 µV
		Current		50 fA	50 fA	50 fA
		Measurement	Min. resolution	Voltage	0.5 µV	0.5 µV
Gate channel	Max output	Voltage		±100 V	±100 V	±100 V
		Current	DC	±100 mA	±100 mA	±100 mA
			Pulsed	±1 A	±1 A	±1 A
Source	Min. resolution	Voltage		25 µV	25 µV	25 µV
		Current		50 fA	50 fA	50 fA
		Measurement	Min. resolution	Voltage	0.5 µV	0.5 µV
Capacitance measurement	Max bias	Gate		±100 V	±100 V	±100 V
		Collector/Drain		±3000 V	±3000 V	±3000 V
		Frequency range		1 kHz to 1 MHz	1 kHz to 1 MHz	1 kHz to 1 MHz
	Capacitance range			10 fF to 1µF	10 fF to 1µF	10 fF to 1µF

Characteristics	Category	Parameters
Static characteristics	Threshold voltage	V(th),Vge(th)
	Transfer Characteristics	Id-Vgs, Ic-Vge, gfs
	On resistance	Rds-on, Vce(sat)
	Gate leakage current	Igss, Iges
	Output leakage current	Idss, Ices
	Output Characteristics	Id-Vds, Ic-Vce
	Breakdown voltage	BVds, BVces
Gate charge characteristics	Gate Charge	Qg, Qg(th), Qgs, Qgd, Qsw, Qsync,Qoss
Capacitance characteristics	Gate Resistance	Rg
	Device Capacitance	Ciss, Coss, Crss, Cgs, Cgd, Cies, Coes, Cres
Power loss		Driving loss/Switching loss <sup>1</sup> Conduction loss at a specified duty cycle <sup>2</sup>

1. Driving loss and switching loss are calculated by measured Qg characteristics, Vth and Rg at a specified frequency.

2. Conduction loss is calculated from measured Rds-on and peak current.



## Ordering information

Ordering Information		
Model number	Option	Description
B1506A		Power Device Analyzer for Circuit Design
	H21	20 A/3 kV/C-V/Gate Charge/Thermal Fixture Package
	H51	500 A/3 kV/C-V/Gate Charge/Thermal Fixture Package
	H71	1500 A/3 kV/C-V/Gate Charge/Thermal Fixture Package
	Thermal enclosure	
	T01	Thermal Test Enclosure (Thermostream Compatible)
	Power line frequency	
	050	50 Hz Line Frequency
	060	60 Hz Line Frequency
	Documentation	
	ABA	English User's Guide
	ABJ	Japanese User's Guide
	Calibration	
	UK6	Commercial calibration certificate with test data
A6J	ANSI Z540-1-1994 Calibration	
Drive option		
DR1	Replace A Built-in DVD-R Drive With A Read-only DVD Drive	
B1506AU	Current upgrade	
	005	20 A to 500 A Current Upgrade Option
	015	500 A to 1500 A Current Upgrade Option
	Accessories	
	T01	Thermal Test Enclosure (Thermostream Compatible)
	F02	Blank Silicon Plate
	F10	3-pin Inline Package Socket Module
F14	Gate Charge Socket Adapter	

If the above specifications do not meet your requirements, then please consider the B1505A Power Device Analyzer/Curve Tracer as it has additional capabilities.

**myKeysight**

myKeysight

[www.keysight.com/find/mykeysight](http://www.keysight.com/find/mykeysight)

A personalized view into the information most relevant to you.

**Three-Year Warranty**

[www.keysight.com/find/ThreeYearWarranty](http://www.keysight.com/find/ThreeYearWarranty)

Keysight's commitment to superior product quality and lower total cost of ownership. The only test and measurement company with three-year warranty standard on all instruments, worldwide.



**Keysight Assurance Plans**

[www.keysight.com/find/AssurancePlans](http://www.keysight.com/find/AssurancePlans)

Up to five years of protection and no budgetary surprises to ensure your instruments are operating to specification so you can rely on accurate measurements.



[www.keysight.com/go/quality](http://www.keysight.com/go/quality)

Keysight Technologies, Inc.  
DEKRA Certified ISO 9001:2008  
Quality Management System



**Keysight Channel Partners**

[www.keysight.com/find/channelpartners](http://www.keysight.com/find/channelpartners)

Get the best of both worlds: Keysight's measurement expertise and product breadth, combined with channel partner convenience.

[www.keysight.com/find/b1506a](http://www.keysight.com/find/b1506a)

For more information on Keysight Technologies' products, applications or services, please contact your local Keysight office. The complete list is available at: [www.keysight.com/find/contactus](http://www.keysight.com/find/contactus)

**Americas**

Canada	(877) 894 4414
Brazil	55 11 3351 7010
Mexico	001 800 254 2440
United States	(800) 829 4444

**Asia Pacific**

Australia	1 800 629 485
China	800 810 0189
Hong Kong	800 938 693
India	1 800 112 929
Japan	0120 (421) 345
Korea	080 769 0800
Malaysia	1 800 888 848
Singapore	1 800 375 8100
Taiwan	0800 047 866
Other AP Countries	(65) 6375 8100

**Europe & Middle East**

Austria	0800 001122
Belgium	0800 58580
Finland	0800 523252
France	0805 980333
Germany	0800 6270999
Ireland	1800 832700
Israel	1 809 343051
Italy	800 599100
Luxembourg	+32 800 58580
Netherlands	0800 0233200
Russia	8800 5009286
Spain	0800 000154
Sweden	0200 882255
Switzerland	0800 805353
	Opt. 1 (DE)
	Opt. 2 (FR)
	Opt. 3 (IT)
United Kingdom	0800 0260637

For other unlisted countries:  
[www.keysight.com/find/contactus](http://www.keysight.com/find/contactus)  
(BP-09-04-14)



Keysight B1505A Power Device Analyzer/Curve Tracer (1500 A/10 kV)  
[www.keysight.com/find/b1505a](http://www.keysight.com/find/b1505a)



Keysight B1500A Semiconductor Device Analyzer  
[www.keysight.com/find/b1500a](http://www.keysight.com/find/b1500a)



Keysight B2900 Precision Instrument Family  
[www.keysight.com/find/b2900a](http://www.keysight.com/find/b2900a)

