

Keysight Technologies

Overcome Your Test Challenges with the 33600A Series Trueform Waveform Generators

Application Compendium

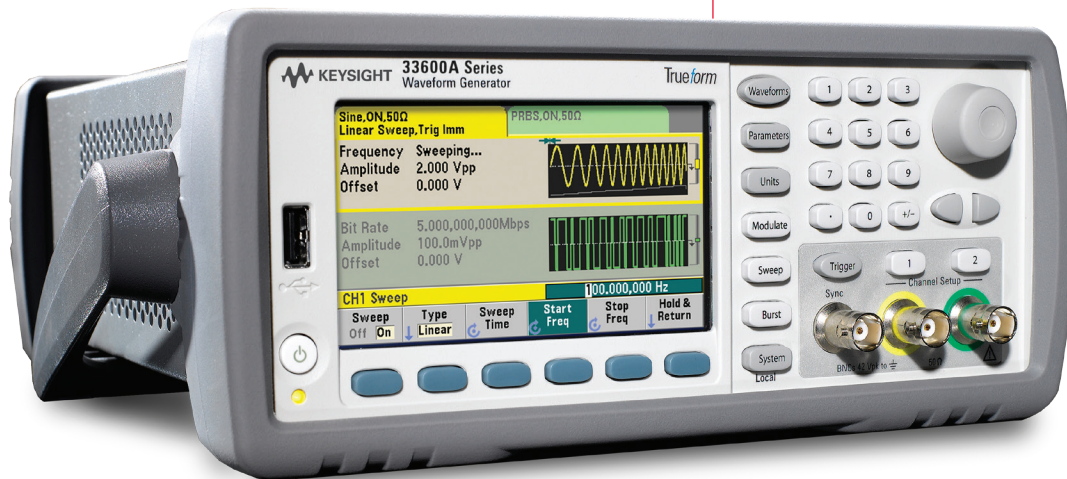

A compendium of six 33600A Series test challenge application briefs



Introduction

Generating the signals you need for your measurements can be a tedious and time-consuming task, one that's often complicated over uncertainty whether your signal generator is outputting the signals you expect. The Keysight Technologies, Inc. 33600A Series of waveform generators with exclusive Trueform technology offer you the capabilities, fidelity and flexibility you need to easily and confidently generate signals for even your most complex tests. Superior signal integrity guarantees you the highest resolution and lowest distortion for playing arbitrary waveforms with a complete representation of signals and creating complex waveform sequences. The ability to choose from a range of different upgradeable models means you have the functionality you need to easily address your test challenges today and in the future.

Some of the key test challenges for which the 33600A Series Trueform waveform generators are especially well suited include:

| | |
|--|----|
| Simulating Signals with the Highest Integrity | 3 |
| Be More Efficient Designing Your Arbitrary Waveforms..... | 6 |
| Generating a Waveform with Many Points..... | 8 |
| Effortlessly Couple or Synchronize Two Signals on a Waveform Generator..... | 11 |
| Using a Waveform Generator to Generate a Pseudo Random Binary Sequence (PRBS) Signal..... | 14 |
| Creating a Differential Signal with a Waveform Generator..... | 17 |

Simulating Signals with the Highest Integrity

| Test challenge examples: | How Trueform technology can help: |
|---|---|
| <ul style="list-style-type: none"> - Reproducing an arb with designed glitches - Running arbs at a fast frequency with the same signal from cycle to cycle - Simulating a complex signal - Needing the best signal quality possible | <ul style="list-style-type: none"> - Trueform waveform generators are the best in the industry - Jitter at < 1 ps - Plays every point as designed without having to force fit a number of samples - Output voltage with load settings - None of the weaknesses of DDS (e.g., distorted signals and stretched points) - 14-bit resolution |

A signal source is often needed in test and measurement applications. Whether you are in R&D or manufacturing, a good signal generator is essential for providing signals that are controlled and predictable. Many test and measurement companies offer signal generators based on direct digital synthesis (DDS) that use a fixed clock to simulate your signal. This fixed clock technology adds or reduces points in your signal to meet the fixed clock rate and as a result, may generate a signal that is different than what you designed. In contrast, Trueform waveform generators use a technology that plays every point in your signal exactly as you designed it.

See our test challenges below to learn how Trueform waveform generators can help you generate accurate signals for all your test needs:

Reproducing an arb with designed glitches

You need to test the robustness of your design. You create a test signal that will really give your design a workout with noise, overshoot, fast voltage spikes, dropouts – every glitch your design might encounter. You tried to use a DDS-based waveform generator to output the signal, but noticed that the glitches weren't actually being reproduced as you designed them. That's because DDS-based generators either add or skip points from a signal in order to meet their rigid arb generation rules. Trueform waveform generators don't have the same restrictions and therefore, can reliably reproduce the signal you designed, even the glitches.

Simulating a complex signal

The custom signal you designed is very complex with many points and very fast transitions that are absolutely critical. Naturally, you would expect that when you use your arbitrary waveform generator the output signal would be exactly as you had designed. Unfortunately, your DDS-based waveform generator isn't able to recreate the fast characteristics that you put into your design. This is not just a bandwidth issue, rather, it is fundamental to the design of the DDS-based generator. In fact, it doesn't even look like the same signal from cycle to cycle. Trueform waveform generators can simulate even the most complex signals. The 33600A Series has 1 GSa/s sample rates and can reproduce your signals **exactly with revolutionary patented technology**.

Running arbs at a fast frequency with the same signal from cycle to cycle

With traditional DDS-based arbitrary waveform generators not every individual point is ensured to play as designed. DDS technology provides a good approximation of designed arbitrary waveform signals, but can skip and/or repeat points of the waveform in an unpredictable way. This can lead to additional jitter or severe distortion in the case of faster frequencies. Even worse, the distortion can be different from cycle to cycle, leading to a non-repetitive waveform and, that distortion will be different at different frequencies. Trueform waveform generators' patented technology ensures that every point of your arbitrary signal is generated exactly as you designed. The arbitrary waveform will be more accurate, have less than 1 ps of jitter, and present less distortion than DDS.

Needing the best signal quality possible

If you are looking for a waveform generator, you will want one that generates the highest signal quality to handle your present and future needs. Trueform waveform generators' sine waves offer 5x better harmonic distortion than other generators. Jitter performance on the 33600A Series is an incredible 200x better than DDS-based generators. Moreover, if you are creating custom arbitrary waveforms, Trueform waveform generators are the only instruments in this class capable of playing each and every point of your waveform as you designed it, at any frequency you choose. No compromises. Trueform waveform generators offer three different output filters (Normal, Step, None) that can be used to optimize your output. Their performance rivals that of much more expensive Point-Per-Clock (PPC) based generators. With up to 120-MHz bandwidth and up to 1 GSa/s, the Trueform waveform generators offer versatility and performance at a DDS-class competitive price.

Simulating Signals with the Highest Integrity *(continued)*

Trueform versus DDS

Waveform generators output the desired waveform by stepping through the waveform data points. Because DDS generators have a fixed sample clock, if they output one unique point for each sample clock, you would only be able to output one frequency. When a slower frequency is needed, the generator needs to use many clock cycles to output a single point and will repeat points. When a fast frequency is needed and the generator can't output all of the points in waveform memory, it will skip over some points. The faster the frequency, the more points are skipped and looks less like the original signal. Furthermore, DDS generators use internal algorithms to determine which points are skipped. These algorithms put a priority on phase of the signal, which results in signals that don't necessarily skip the same samples in every cycle.

Trueform waveform generators use exclusive technology that allows waveforms to be expressed with the same shape, regardless if the signal is 1 Sample/s or the maximum rate of 1 GSamples/s. Designers working with complex waveforms can use Trueform generators to generate signals with complex modulation and abnormalities (within the constraints of physics). Digital waveforms with transients and pulses can be reproduced with the same characteristics every time. By comparison, DDS-based arbitrary waveforms will sometimes distort your signal from cycle to cycle.

Figure 1 shows an example of the same signals at the same frequency but on two different generators. Channel 1 (yellow) is measuring a DDS-based generator; channel 2 (green) is measuring a Trueform waveform generator. Notice that the DDS channel is missing characteristics and the signal is different from cycle to cycle. The Trueform generator waveform clearly shows there are three small bumps in the signal. The small bump in the DDS-based signal is distorted and is sometimes missed altogether.

One other benefit of the Trueform generators' architecture is the jitter. Cycle-to-cycle jitter is specified for the 33600A Series at less than 1 ps, for all waveforms including arbitrary, sine, and

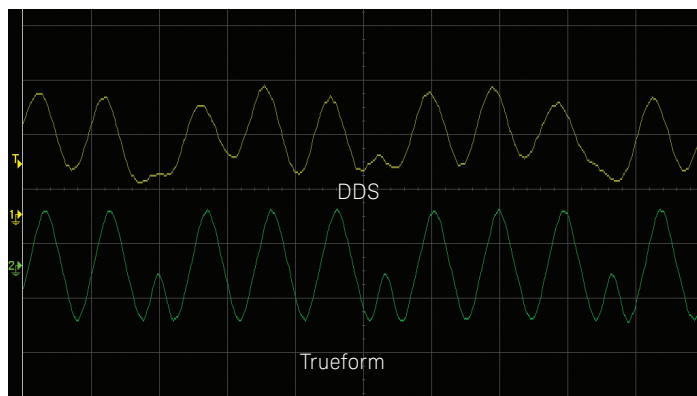

Figure 1. Two signals at the same frequency measured using different waveform generators.

square waves. That's about 200 times less jitter than DDS-based generators. Figure 2 shows a screen shot from a signal source analyzer. A signal source analyzer is one of the few instruments that can measure jitter at less than 1 ps (although it is measuring RMS jitter). The analyzer is measuring a 40-MHz sine wave signal with less than 800 fsec of jitter.

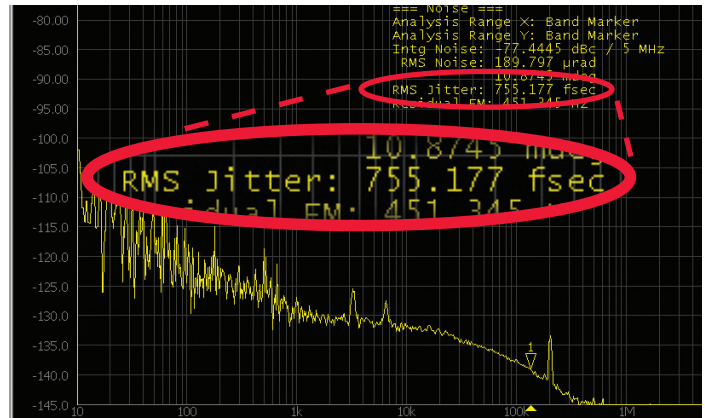

Figure 2. Signal source analyzer measurement screen.

As another visual example, we created a sample arbitrary waveform to illustrate the points that are skipped by DDS generators. Figure 3 shows a basic square wave with seven aberrations, each with less amplitude than the previous one. At 1 kHz, both the DDS signal (yellow) and the Trueform waveform generator signal (green) reproduce all seven aberrations quite well.

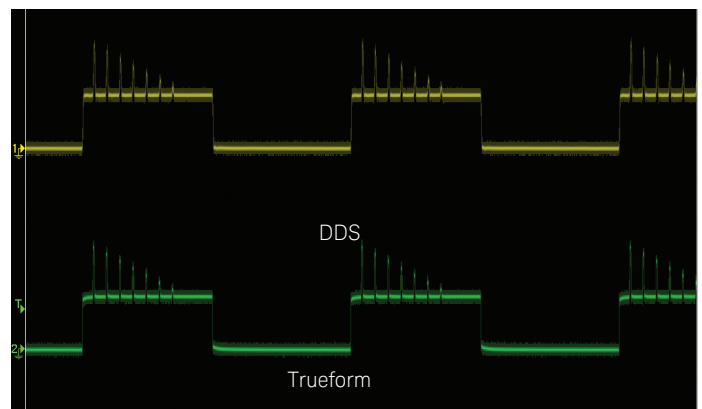

Figure 3. Same arb at 1 kHz.

Measurement tip:

Even if you are looking for a simple sine wave generator, the 33600A Series waveform generators, with their minimal distortion (< 0.03% THD), can help clean up your signals.

Simulating Signals with the Highest Integrity *(continued)*

However, if we bump the frequency of the arb to 2 MHz, we can see that the yellow DDS signal is now missing the first three aberrations (Figure 4). The green Trueform signal is still generating all seven points. At even higher frequencies, the aberrations can be played only intermittently, have varying amplitudes, or even all disappear from the DDS-based generator.

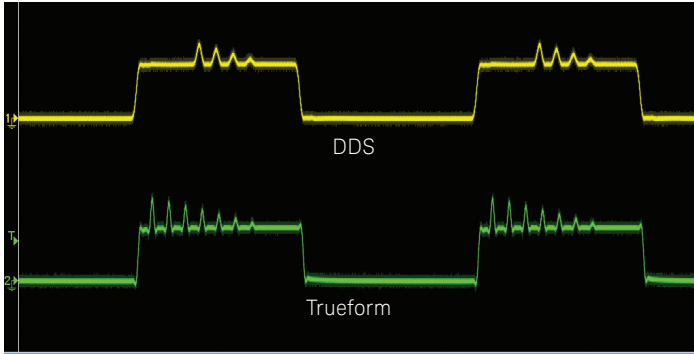

Figure 4. Missing points at 2 MHz.



Summary

For decades DDS technology has been used by waveform generators. It offered good signal quality at a low cost, especially when compared to Point-Per-Clock (PPC) generators which can be more than 10x the cost of a DDS generator. However, with Trueform waveform generators, Keysight has improved on the jitter, signal integrity and ability to output every point in your designed arbitrary waveform. All that performance is offered at the same price range as DDS based generators.

See the companion video for this test challenge and get more information at: www.keysight.com/find/trueformTC

Measurement tip:

Arbitrary waveforms can be affected by the shape of the output filter. For digital waveforms on the 33600A Series, use the “No” filter path for sharper edges. This limits your sample rate to 250 MSa/s so that the analog output hardware can keep up.

Measurement tip:

Generating arbitrary files is as easy as creating a .csv file in your own design tool. You can then import the .csv file into a Trueform waveform generator with your choice of I/O. Don't forget about capturing your hardware's signal with a scope and then reproducing it on a Trueform waveform generator.

Be More Efficient Designing Your Arbitrary Waveforms

| Test challenge examples: | How Trueform technology can help: |
|---|--|
| <ul style="list-style-type: none"> - Changing one segment of an arb without redesigning the whole signal - Reusing your proven signal designs but put them together in a different order - Having a signal continuously playing until an event starts another signal - Needing to sweep your arb through a set of different frequencies | <ul style="list-style-type: none"> - Arbitrary waveform sequencing - Arbitrary waveform triggering model - 1 GSa/s - Change amplitude, sample rate and filter settings with arb metadata - Deep waveform memory - Easy drag and drop file system |

Historically, arbitrary waveform design and use had limited flexibility. You simply design a waveform and then use it in your generator. But, if you wanted to change the waveform, you had to regenerate a whole new signal. While you might have been able to change one or two points by hand, changing large parts of the waveform required a complete redesign. Trueform waveform generators now make arb signal generation much more flexible, and your workflow easier, thanks to capabilities like arb sequencing and frequency lists.

See our test challenges below to learn how Trueform waveform generators can help your arb waveforms do more.

Changing one segment of an arb without redesigning the whole signal

You've finally designed your custom arb signal, a stimulus for your Device-Under-Test (DUT), and it works exactly as desired. Using the signal you found defects in your DUT that you didn't expect. Now you'd like to reuse the signal, but add in a few glitches in key areas to ensure that your DUT can handle the transients. With the Trueform waveform generators (both the 33500B and 33600A Series), you don't need to start the signal design process from scratch. That's because an arb sequencing feature gives you the flexibility to easily add in signal characteristics without having to redesign the whole waveform. Furthermore, those glitch characteristics will actually show up in your signal—something not always guaranteed with DDS generators.

Having a signal continuously playing until an event starts another signal

When sending signals to your DUT, you often need to send a different signal when an event occurs. This could be as simple as going from one DC level to another. Perhaps you need to go from a transmission packet to a receive packet. In the past, it was difficult to easily accomplish this task with your function generator. You probably had to send commands to the generator when you wanted a new signal. Did you know that you can accomplish the same thing without a controller and with better timing using Trueform waveform generators (both the 33500B and 33600A Series)? Their waveform sequencing capability enables advanced triggering that allows you to trigger a different signal on a trigger or multiple signals on multiple triggers. Consequently, with a Trueform waveform generator, you are now able to simulate more situations.

Reusing your proven signal designs but put them together in a different order

You've designed arbitrary waveform signals for a while now and are experienced with the tools. However, the signals you need tend to be very similar and it sometimes seems like all you do is shuffle their order to test out different characteristics of your DUT. If you're like most engineers, you're always looking for ways to become more efficient. Why not save development time with your arbitrary waveforms? Trueform waveform generators (both the 33500B and 33600A Series) allow you to build a library of arbs and combine them into sequences to create whole new waveforms. You can then easily re-sequence the arbs into any order you like. And, with the deep waveform memory available on the Trueform waveform generators, you can store numerous arb signals on your instrument so that you can change your arbs faster.

Want your arb to sweep through a set of different frequencies

You've designed your signal using a PC and uploaded it to a signal generator. You realize, however, that you want the signal to have different sample rates or frequencies while still retaining its same shape. An example of this would be testing different resonant frequencies in mechanical structure testing where you want to automatically test a set of varying frequencies. With most DDS instruments, you would need to manually change the frequency each time you performed a different test. Trueform waveform generators allow you to more efficiently perform this task using frequency lists. Now, you can save time going from frequency to frequency by setting a list of frequencies and the dwell time right in the instrument.

Be More Efficient Designing Your Arbitrary Waveforms *(continued)*

Design arbitrary waveforms more efficiently

As an engineer, you'd like to reuse as much of your work as possible. Whether it's programming or a circuit design, you know that it's an efficient and good practice to reuse your proven designs. Why should building an arbitrary waveform be any different? If you've already designed a signal and now need to redesign a single part of it, you shouldn't have to recreate the whole thing. With Trueform waveform generators you don't have to. You can reuse, re-sort and change parameters on your arbs to build a whole new signal. This approach not only saves you time, but also increases your confidence in the new signal since you are simply reusing parts of a waveform you used in the past.

Waveform sequencing

For those engineers looking to create a more efficient workflow to generate arbitrary signals, waveform sequencing may be just the answer you need to streamline your development. Using it, you can develop a library of arbitrary waveform signals and then reorganize the signals into a sequence to make a new signal. A sequence is simply an ordered list of arbitrary waveforms that run one after another at a specified sample rate.

In the Trueform waveform generators, arbitrary signals are stored as .arb, .csv or .dat files. The sequence is stored as a .seq file. A sequence can have up to 512 steps. A total of 32 sequences with up to 1,024 segments can be pre-loaded into the generators' volatile memory to improve throughput.

Measurement tip:

The 33600A Series can store up to 64 Msamples (optional) waveforms. With waveform sequencing, you can save memory by replaying different shorter waveforms at different locations in your signal as needed.

The following is an example that uses Keysight BenchLink Waveform Builder Pro to build a new signal from a library of arbs.



Figure 1. BenchLink Waveform Builder Pro sequencing menu.

As you create your sequence there are four parameters to configure for each arb:

- Play control (repetition and trigger configuration)
- Repeat count (number of times to play the waveform)
- Marker mode (behavior of Sync signal)
- Marker point (point in waveform at which Sync signal changes)

As the table in Figure 1 shows, this sequence will play "MyArb1" until a trigger is received. It will then play "MyArb4" 200 times, and will finish by playing "MyArb2" indefinitely. The Sync signal is maintained at its current level throughout the sequence.

Measurement tip:

For more complex sequences, you can use Keysight BenchLink Waveform Builder Pro software (a program you can purchase to run on your PC) to construct a sequence.

Frequency lists

Most generators have a way to sweep through a range of frequencies. They enable you to output your signals at different frequencies linearly or logarithmically. Trueform waveform generators allow you to define a frequency list and set how long you want to dwell at that frequency. Now, you can set a list of up to 128 frequencies and set your dwell time. The generator then sequentially goes through the list of frequencies, staying at each frequency for the defined dwell time. This feature can be used for all waveform types including arbs.

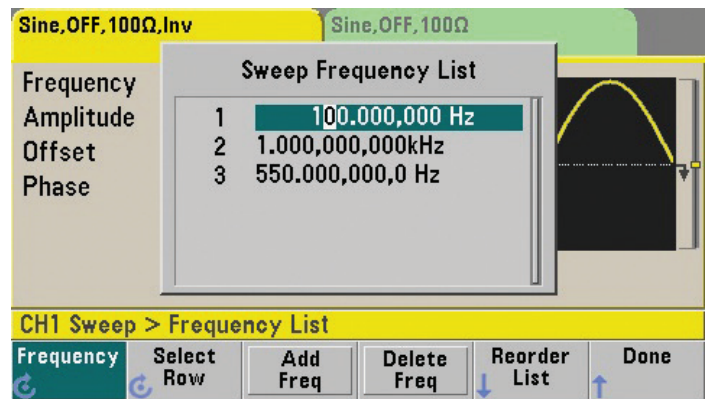

Figure 2. Trueform waveform generator frequency list menu.

Summary

The 33600A Series of Trueform waveform generators builds on the features of its predecessor, the 33500B Series waveform sequencing and frequency lists are just two of the new capabilities unique to the Trueform waveform generators.

Generating a Waveform with Many Points

| Test challenge examples: | How Trueform technology can help: |
|--|--|
| <ul style="list-style-type: none"> - Creating long non-repeating signals - Creating signals requiring fine time resolution - Simulating a digital data protocol - Simulating a digitally modulated carrier | <ul style="list-style-type: none"> - Deep waveform memory - 1 GSa/s arb sampling rate - Trueform waveform generator accuracy - Ample onboard memory to store waveforms |

Memory depth in your waveform generator might not be something that you've spent a lot of time thinking about. However, today's designs require increasingly complex waveforms that often stretch beyond current generators memory depth. Trueform waveform generators offer the most waveform memory depth in their class.

See our test challenges to learn how Trueform waveform generators can provide you the memory depth you need to output long or complex waveforms.

Long non-repeating signals

If you want your generator to produce long custom signals that don't repeat, then you are going to need more waveform memory. These signals might not be very complex, but their non-repeating nature requires a lot of samples. Some conventional bench Direct Digital Synthesizer (DDS) generators offer only 128 KSa of waveform memory. In contrast, the 33600A Series Trueform waveform generators offer 4 MSa per waveform, with optional upgrades for up to 64 MSa of waveform memory. That means that with a Trueform waveform generator your signal can be 500 times longer than with a conventional DDS generator.

Simulating a serial digital protocol

If you are simulating a complex digital data signal with lots of bits, such as a USB data transfer, the need for deeper waveform memory is easy to understand. Each bit in your signal is expressed as one or more samples in your generator's waveform memory. The more data in your signal, the more waveform memory you need. The Trueform waveform generators' deeper memory option can help you reproduce your signals fully, without the need to compromise on their length. Moreover, with less than 1 ps of cycle-to-cycle jitter, you can be assured that the timing of your signal has maintained its integrity.

Simple signals requiring a lot of time resolution

Another scenario where longer waveforms are useful is when you need to have a very fine time resolution. Your signal might be as simple as a square wave, but to test your device you might need a very short voltage drop requiring 1 ns of resolution. The 33600A Series Trueform waveform generators feature a 1-GSa/s arbitrary waveform capability. Additionally, a patented sampling technology that never adds or skips points in your waveform—a common weakness in traditional DDS-based generators—guarantees that your voltage drop will be reproduced.

Simulating a digitally modulated carrier

You need a signal simulating a digitally modulated carrier for wireless data transmission. The digital signal needs lots of memory because it has some connection protocol requiring many bits of data, and it takes many samples of memory to simulate each bit of data in the over-the-air signal. Trueform waveform generators are ideal for this scenario, featuring a 14-bit amplitude resolution, deep memory and high signal integrity to represent over-the-air signals at very low Error Vector Magnitude (EVM).

Generating a Waveform with Many Points (continued)

Deeper memory

Whether it is your hard drive, or your smart phone, it's likely you've seen the benefits of having more memory. The same holds true for waveform generators. More waveform memory allows you to re-create longer signals and gives you more control over the time resolution of your signal.

Consider a time resolution example in which a square wave with a very short glitch is required to simulate voltage dips in your modeled system (Figure 1). With the signal's time resolution of 1 ns, we extract how a deeper memory translates into time. A 1-GSa/sec sampling rate is needed for this type of resolution. If your generator only has 128 KSa of waveform memory, your signal's length would be limited to 128 μ s. In contrast, with the 64-MSa waveform memory available from the 33600A Series Trueform waveform generator, your signal could be up to 64 ms –500 times as long. A longer signal could help ensure that your Device-Under-Test (DUT) has enough setup and hold time to detect your signal level.

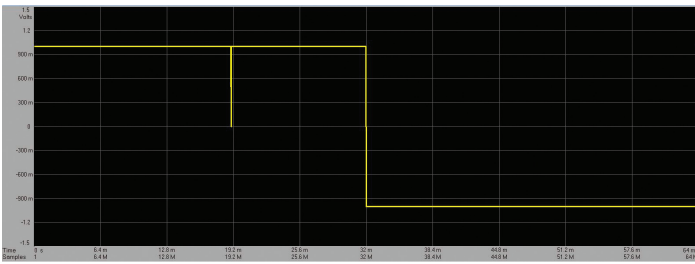

Figure 1. Square wave with short duration voltage drop.

Another limitation of the DDS generator has to do with reproducing arbs. Since DDS is a fixed clock technology, it needs to add or skip points to meet the sampling rate and the output frequency that you define. This results in transitions being skipped, often unpredictably or at random, and can result in your voltage drop characteristic being skipped with your DDS generator. The reason why DDS skips and adds points is beyond the scope of this paper; however, you can refer to *Trueform Waveform Generation Technology* (pub no. 5991-0852EN)

Trueform technology is also an excellent signal-generation technique for digital signal simulation. Not only does the deeper memory depth help ensure you have enough waveform points to simulate your long digital signal, but the performance is unmatched by DDS generators in the same price range. DDS generators sometimes have a weakness that introduces one sample period of jitter when transitioning using fast edges (slower edged signals like sine waves are not affected). This means that 1-GSa/sec DDS-based generators can introduce up to 1 ns of jitter on your signal. Trueform's patented technology does not have this issue. It is specified to have less than 1 ps of jitter even on fast edges, which is up to 1000 times better on arbitrary waveforms.



Figure 2. Femtosecond jitter.

While this type of performance would normally require a much more expensive instrument, Trueform generators are competitively priced with DDS-based generators.

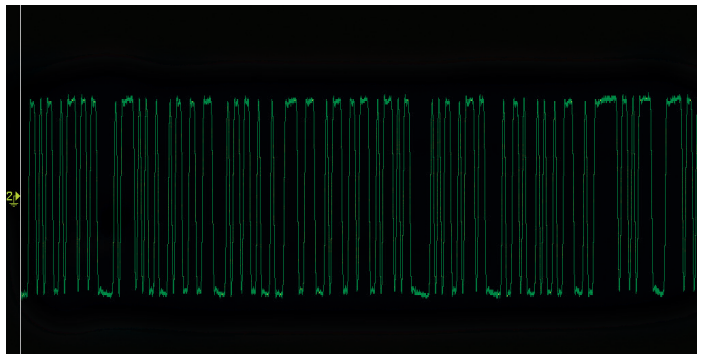

Figure 3. Arbitrary waveform simulating a digital data signal with many points.

Measurement tip:

Even if you are looking for a simple sine wave generator, the 33600A Series waveform generators, with their minimal distortion (< 0.03% THD), can help clean up your signals.

Easier importing of arb signals

Traditionally, moving a signal from your PC to your generator has been a difficult task, often requiring you to write your own code or use proprietary software to move the signal. The 33600A Series Trueform waveform generators now make file I/O easier and the process of moving files to your generator much more intuitive.

Assuming you connect your generator to your PC via USB, you can now simply drag and drop files onto your generator just like you would with a normal USB storage device (e.g., a thumb drive). The instrument shows up in your explorer window like a normal drive, allowing you to read/write to the drive as you usual. The Trueform waveform generators are the first to offer this capability.

Generating a Waveform with Many Points (continued)

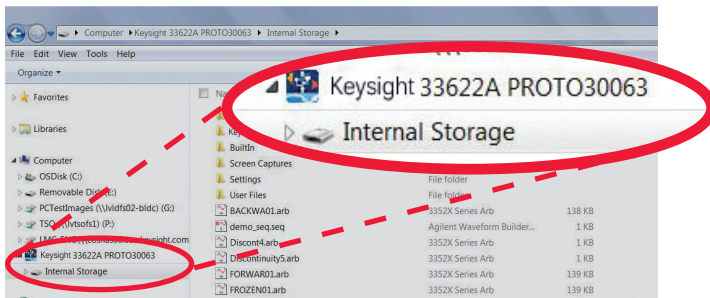

Figure 4. Windows Explorer with USB connected 33622A.

A front panel USB drive port is available on the generator as well. You simply plug your USB drive into the generator and move files using the front panel interface.

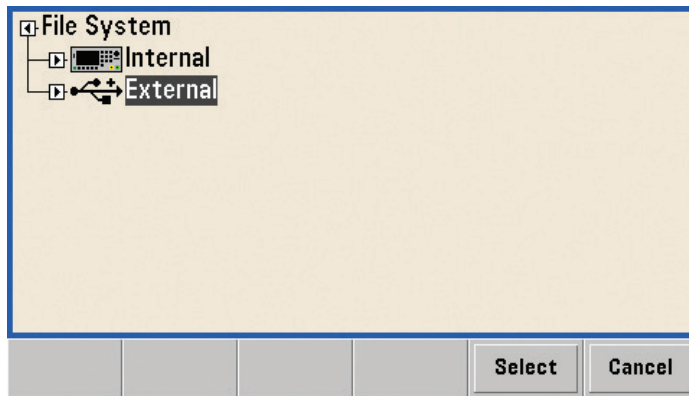

Figure 5. Front panel access to USB drive.

Of course, the Trueform waveform generators also provide the traditional methods of file I/O too. SCPI commands, for example, are still supported for programmatic file moving. Additionally, Keysight BenchLink Waveform Builder Pro enables the easy transfer of arbitrary waveform files using USB, GPIB or LAN.



Summary

Trueform waveform generators offer unmatched performance, usability and innovation at a competitive price. With deeper memory, your signals don't need to be compromised. Trueform performance ensures your signal will be reproduced exactly as designed. And, it's now easier than ever to move files to the Trueform waveform generators. With four models to choose from, you are guaranteed to find the right price point for your project.

See the companion video for this test challenge and get more information at: www.keysight.com/find/trueformTC

Effortlessly Couple or Synchronize Two Signals on a Waveform Generator

| Test challenge examples: | How Trueform technology can help: |
|---|---|
| <ul style="list-style-type: none"> - IQ modulation testing - Provide a stimulus for device and trigger signals - Simulating a differential pair signal - Creating a frequency relationship on two signals | <ul style="list-style-type: none"> - Dual channels - Easy frequency coupling - Easy amplitude coupling - Match or mirror signals between two channels |

It can be challenging for engineers to couple two signals together with a phase, amplitude or frequency relation. They need to ensure that if the parameter changes it changes on both signals. While the two signals by themselves might be simple, the act of keeping track of both of them is incredibly tedious. Dual-channel Trueform waveform generators now make keeping track of two signals much simpler. Using these waveform generators, coupling your signals together has never been easier or more accurate.

See our test challenges below to learn how Trueform waveform generators can help you effortlessly couple or synchronize two signals:

IQ modulation testing

You need to generate an I/Q signal to test your RF component or system design such as a converter or signal conditioning system. The testing involves qualifying a number of parameters such as IQ gain imbalance, frequency response or quadrature error. You would like to generate the signal easily, without a significant financial investment and with a short learning curve. Two-channel Trueform waveform generators with up to 120-MHz bandwidth can easily simulate I/Q signals thanks to their built-in coupling features and incredible jitter performance. Optional I/Q generation software for the waveform generators now makes it even easier to go from simulation to signal generation output.

Simulating a differential pair signal

Generating a differential pair signal from a waveform generator isn't intuitive. With differential signals, you want to create complimentary signals to carry your data, which helps reject noise from external interference. Waveform generator outputs, on the other hand, are configured to be a referenced signal with a single wire and a reference for the return path. Two-channel Trueform waveform generators can be easily configured to output differential signals. Creating complimentary signals or matching signals is a single setting with the Trueform Series waveform generators. With 14-bit amplitude resolution, signals now have enough accuracy to simulate your real-world outputs.

Provide a stimulus for device and trigger signals

If you're testing a semiconductor (e.g., an RFID receiver IC) you need a trigger signal to initiate your test. You must be able to generate a test signal and trigger at the same time. Waveform generators, with their amplitude adjustment feature, variable trigger widths and signal delays, are ideal for this task. With the dual-channel synchronization and phase matching available in the Trueform waveform generators, generating stimulus and trigger signals is now simpler than ever.

Creating a frequency relationship on two signals

You want to generate two clock signals where the clock frequency of one signal is a fraction of the other's frequency. You could do this with two separate waveform generators, but if you want to vary the frequencies while keeping the signals' frequency relationship in sync, you would need large amounts of manual work or programming. With the Trueform waveform generators' dual-channel operation modes, keeping two signals coupled together is easy and will save you development time. With up to 120-MHz bandwidth, the Trueform waveform generators can help you test your components from design validation through production testing.

Effortlessly Couple or Synchronize Two Signals on a Waveform Generator (*continued*)

Phase synchronization or a 90-degree relationship for IQ signals

If timing between two channels is important to you then being able to control the phase between two channels is essential. In the previous stimulus and trigger example, the key factor was the time synchronization of the trigger and stimulus signals. If you use the normal built-in functions (e.g., sine wave, square wave, pulse, triangle, or PRBS) on both channels you can easily synchronize the channels by going to the **parameters** button > **phase** > then **sync internal**. This will start both channels at the same time. You simply change the phase to obtain different delays between the two channels.

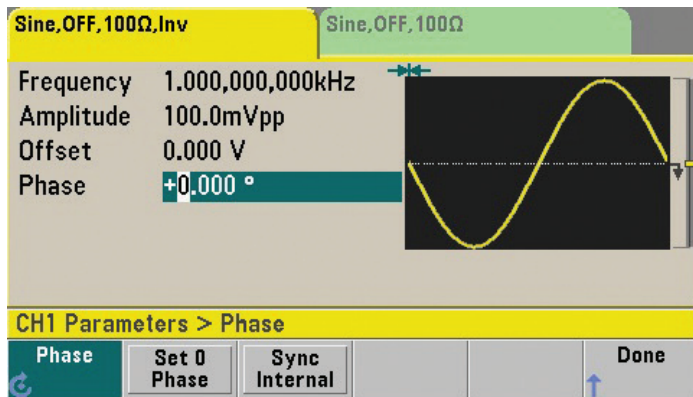

Figure 1. 33600A Series' menu for internal phase sync.

Similarly, for custom IQ signals, you will want to keep a 90-degree relationship between your I and Q channels. To accomplish this you simply set the signals to initiate at the same time and then load both arbs onto channel 1 and 2. Finally, go to the parameters menu and press the **SYNC ARBS** button (on the second page of buttons).

With the 33600A Series Trueform waveform generators, you can even change the units for the phase parameter. All that's required is to go to the **units** menu and choose **phase**, which gives you a choice of degrees, radians, seconds, or sample (for arbs).

Measurement tip:

IQ signal generation has now been made even easier with the IQP option for Trueform waveform generators. This IQ signal player option configures and controls both channels as if they were a single channel. It also keeps the phase of each channel in nominal IQ range. For more details, refer to: *Simplify the Generation of High Quality IQ Signals* (pub no. 5991-1048EN).

Easy creation of differential signals

Trueform waveform generators make it easy to mirror two signals to create a differential signal. You simply use the inverted tracking capability that is available when the unit is in dual-channel operation mode. This mode forces channel 2 to be a mirror image of the signal from channel 1, which is exactly what you need for a differential signal. Once you have this enabled mode, all you need to do is set up your signal on channel 1 and it will be inverted on channel 2 to create your differential signal. For more information, refer to: *Creating a Differential Signal with a Waveform Generator* (pub no. 5991-3992EN)

Frequency and amplitude coupling

Frequency coupling allows you to specify that one channel's frequency is related to the other channel's frequency either by a ratio (multiplying) or an offset (adding). To access this setting, you simply press the channel output key above either channel's output connector. Then, press **More** > **Dual Channel** on the soft-key menu. Enabling this feature and setting the offset or ratio will save you configuration time. Rather than setting it for both channels, the Trueform waveform generator will keep track of your settings for you. In other words, changing channel 2's frequency will change channel 1's frequency to maintain the specified offset or ratio.

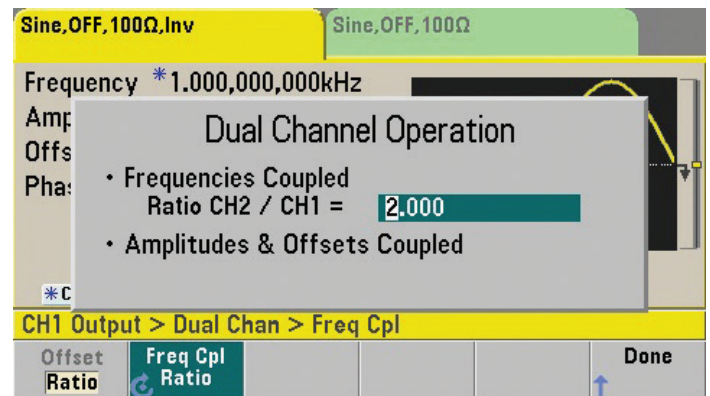

Figure 2. Frequency coupling with the generator in dual-channel operation mode.

Similarly, amplitude coupling ensures that the amplitudes and offsets on both channels are the same, even if you make amplitude changes on only one channel.

Effortlessly Couple or Synchronize Two Signals on a Waveform Generator *(continued)*



Summary

Using a two-channel Trueform waveform generator enables fast simulation of your signals. Whether you want to create an IQ signal, differential signal, or have a relationship between two channels, the Trueform waveform generators provide the ideal solution. Using them, the signal generation process has never been simpler, quicker or less frustrating.

See the companion video for this test challenge and get more information at: www.keysight.com/find/trueformTC

Using a Waveform Generator to Generate a Pseudo Random Binary Sequence (PRBS) Signal

Test challenge examples:

- Testing a transmission line
- Acoustic testing
- Noise simulation
- Generating an eye-pattern stimulus

How Trueform technology can help:

- Built-in PRBS functions
- PN3 through PN32
- Up to 200-Mbps bit rate
- Jitter at < 1 ps
- Synchronized output for external clocking
- 2-channel coupling

Pseudo Random Binary Sequence (PRBS) signals are very useful in digital communication testing. They may be generated by a Linear Feedback Shift Register (LFSR) like the one shown in Figure 1. Note that in the figure the branches after register cells 5 and 9 are called taps. The configuration of the LFSR and its taps determines the PRBS waveform.

The 33600A Trueform waveform generators can easily generate PRBS signals for use in a range of applications. See our test challenge examples to learn how PRBS signals and Trueform technology can help you.

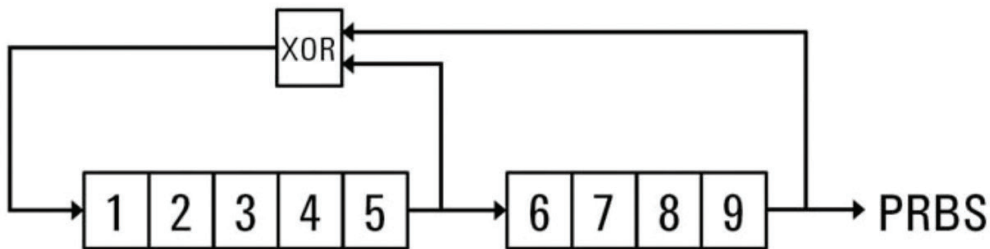

Figure 1. A linear feedback shift register.

Using a Waveform Generator to Generate a PRBS Signal *(continued)*

Testing a transmission line

When testing the integrity of a digital transmission system you need to determine if your system is robust enough to transmit at your data rates. The industry accepted method involves using a PRBS to test the integrity of your link. The PRBS signal has random and autocorrelation properties that help determine if your connection is acceptable. If your design does not include a signal source capable of generating this test signal you can purchase an instrument to simulate the test signals for you. However, a dedicated PRBS generator can be very expensive. The 33600A Series of Trueform waveform generators is less than half the cost of a dedicated PRBS generator. Moreover, it generates PRBS signals ranging from PN3 to PN32, and features best-in-class accuracy and jitter performance.

Acoustic testing

You need to test the acoustics of a structure. That structure could be a room, a cavity or the inside of a speaker box. To test the acoustics, you use a speaker and microphone pair. A PRBS test signal may be sent through the speaker to simulate white noise in a deterministic manner. The microphone is then connected to a scope that reads the signal and helps determine the loss through the structure. With the 33600A Series Trueform waveform generator, generating that PRBS signal is now easier than ever before. Its' built-in PRBS signals may be easily accessed and configured via the front panel, programmatic interface or Web user interface.

PRBS generation

The 33600A Series is the latest addition to the versatile family of Trueform waveform generators, which feature traditional built-in waveforms (sine, square, triangle, ramp, pulse, arb, and triangle) and the ability to generate both noise and PRBS signals.

The 33600A Series' PRBS signals have a maximum bit rate of 200 Mbps and allow you to specify a signal's falling- and rising-edge transition times down to 2.9 ns. An amplitude range of 1 mVpp to 10 Vpp, enables the waveform generators to generate signals for a wide variety of applications.

Noise simulation

Do you want to simulate noise on your digital line? One way to simulate generated broadband digital noise is using a PRBS signal. PRBS signals can simulate white noise as N , the number of stages, becomes large. They may also be constructed to cover a wide range of frequency bands that can be adjusted by sequence size and bit rate. If you need to calculate auto-correlation functions, PRBS signals are ideal since their binary nature helps simplify the process. The 33600A Trueform waveform generators make generating PRBS signals simple. Once generated, change the parameters to vary sequence size and bit rate to simulate noise in a variety of bandwidths.

Generating an eye-pattern stimulus

One of the most important ways to determine the quality of a digital transmission system is to measure its Bit-Error-Ratio (BER). BER is calculated by comparing the transmitted sequence of bits to the received bits, and counting the number of errors. The ratio of how many bits received in error over the number of total bits received is the BER. This measured ratio is affected by many factors including: signal-to-noise, distortion and jitter. Using a PRBS signal allows you to determine dropped bits. Its random properties also allow you to test for weaknesses in your system. The 33600A Trueform waveform generators offer built-in PRBS signal generation, which makes generating test signals simple. With their incredible jitter performance, less than 1 ps, they can easily help you isolate your signal source errors from transmission errors.

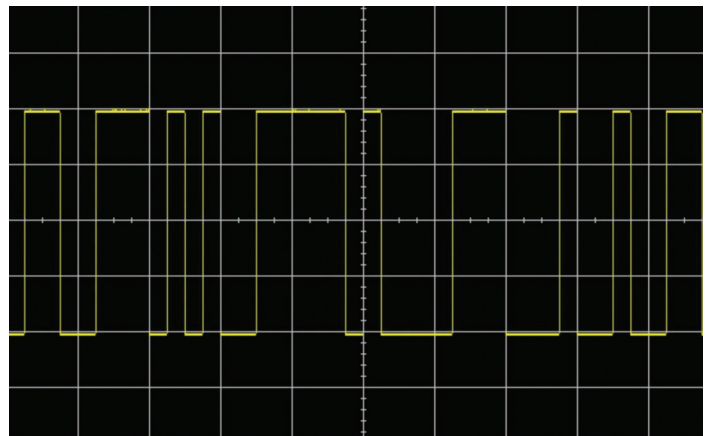

Figure 2. A PRBS signal.

Using a Waveform Generator to Generate a PRBS Signal (*continued*)

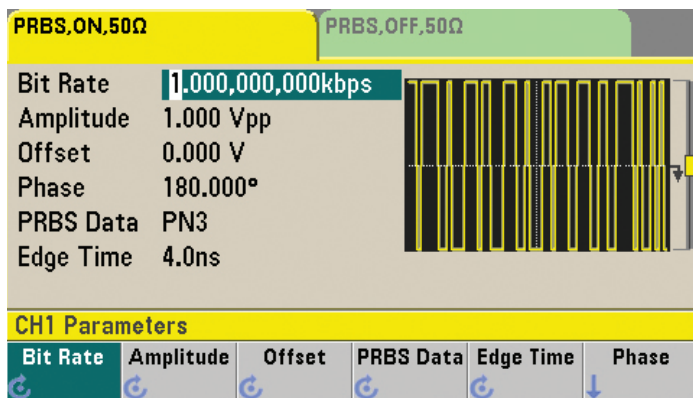

Figure 3. Varying the PRBS signals' bit rate and polynomial function.

The 33600A Series generates PRBS signals with polynomial functions 23-1 through 232-1, otherwise known as PN3 through PN32. The signals comply with CCITT (ITU O-Series) recommendations, which are common in digital transmission testing. Varying the bit rate and polynomial function allows you to generate noise with different frequency content. The 33600A Series also has a standalone noise function if you want to generate analog noise.

To aid transmission analysis, Trueform waveform generators have a sync output that can be used as an external clock reference. This is especially useful for jitter analysis or the construction of eye diagrams. All that's required is to connect the sync output of the generator to your measurement device and ensure that the sync output is enabled.

Due to the patented technology in Trueform waveform generators, the 33600A Series offers incredible jitter stability at less than 1 ps! Having a stable signal source is tremendously beneficial for your system analysis.

For dual-channel 33600A Series' models (33612A and 33622A), you can also couple the channels for dual PRBS outputs. To do this, you simply turn on the channel tracking, which will output the same signal on both channels or invert the polarities. Trueform also easily couples the amplitude or bit rate. For example, you can build a relationship between the two channels so that the amplitudes on channel 2 is twice as large as channel 1. Then, when you change the amplitude on one channel the other channel will remain at twice the amplitude.

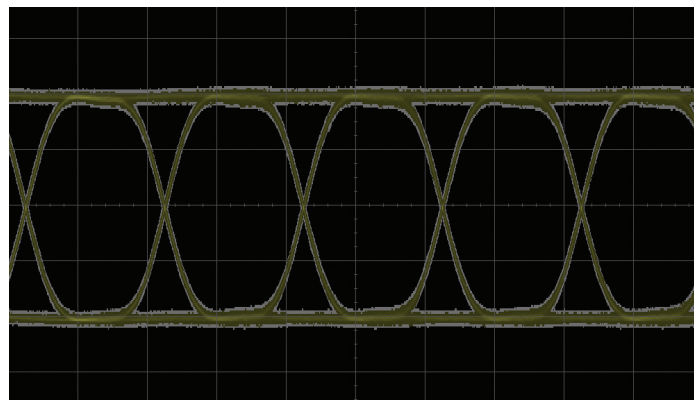

Figure 4. Simple eye diagram for the 33600A Series waveform generator.

Summary

PRBS signals are used industry-wide to qualify digital transmission systems. The 33600A Series Trueform waveform generators can generate PRBS signals up to 200 Mbps. By sending a near random bit stream through your digital network, you can simulate many conditions to look for weaknesses. Other 33600A Series features that help simplify PRBS signal generation include a jitter of less than 1 ps, sync output, and a dual-channel tracking capability.

See the companion video for this test challenge and get more information at: www.keysight.com/find/trueformTC

Creating a Differential Signal with a Waveform Generator

| Test challenge examples: | How Trueform technology can help: |
|--|---|
| <ul style="list-style-type: none"> - Simulating an IC output - Simulating balance twisted pair outputs - Simulating a biomedical signal - Generating an LVDS stimulus signal | <ul style="list-style-type: none"> - Dual channels - Frequency or amplitude coupling - Identical or inverted signals between two channels - Floating outputs up to 42 V - 1 mVpp to 10 Vpp outputs |

Differential signals have many advantages over single-ended signals; namely, fewer timing errors, better signal-to-noise ratio, and better immunity to electromagnetic noise. However, creating a differential signal from previous generation Keysight waveform generators with single-ended outputs is not intuitive or even possible. Trueform waveform generators now make creating a differential signal easier and much more cost effective.

See our test challenges below to learn how Trueform waveform generators can help you create differential signals for a variety of applications:

Simulating an IC output

Test signals are used by engineers to try out their designs. If you are designing analog or digital circuits, or want to reproduce your integrated circuit's output signal, a waveform generator should be your first choice. Using that generator to generate a differential signal; however, might give you second thoughts. Dual-channel Trueform waveform generators can simulate your test signals, even if they are differential. You can capture your signals with an oscilloscope, and then use the Trueform generator to accurately simulate the waveform as a differential signal on your bench. The arbitrary waveforms generated by the Trueform generators output each point without skipping or adding points like DDS-based generators.

Simulating a biomedical signal

When simulating a biomedical signal such as a heart rate to test your equipment, your requirements will include an isolated differential signal and small-amplitude levels. The dual-channel Trueform waveform generators can create small-amplitude, differential signals and do not require an external attenuator. Output levels as low as 1 mV peak-to-peak can be used. The generators even feature a standard cardiac arbitrary waveform in an internal library. Using the 33600A Series Trueform waveform generators, you not only simplify your system design, but also gain the ability to more accurately create versatile test waveforms.

Simulating balanced twisted pair outputs

You need to simulate a balanced, twisted differential pair. The differential pair signals require equal and opposite polarity, and must be tightly timed together. Like any good engineer you want the simulation to be accurate, the development time to be efficient, and the cost to be low. Thanks to the versatility of the Trueform waveform generators, all of your needs can now be met. Dual-channel models make creating a differential pair signal easy, while arb generation tools speed up your development time. Moreover, by adjusting the load impedance setting of the generator to match your load circuit's impedance, you can be assured the amplitude of your waveform will be correct.

Generating a LVDS stimulus signal

Do you need help generating a Low-Voltage Differential Signaling (LVDS) output test signal? Such signals are typically implemented as constant current 3.5-mA signals that terminate into a 100- to 120-ohm load. With Trueform waveform generators, you can now simulate LVDS signals even though waveform generators are typically constant voltage instruments. All you have to do is change the generator's load setting to match your load impedance. With up to 120-MHz of bandwidth and voltage settings ranging from 1 mVpp to 20 Vpp (into high impedance loads), Trueform waveform generators are ideal for helping you reproduce the signals you need.

Creating a Differential Signal with a Waveform Generator *(continued)*

Easy creation of differential signals

In the simplest terms, a differential signal is made up of a pair of wires devoted to a single signal. One path is at a higher potential than the other. Trueform waveform generators have dual-channel isolated outputs that are referenced to the outer shell. In order to combine the two channels into a single differential output, you must connect the two common connections (the connector shells) of each channel. The middle pin (signal pin) of one channel is used as the high signal path of the differential signal, while the signal pin of the other channel is used as the inverse return path. You can connect the connector shells to a cable shield if you would like additional shielding or a ground connection.

With the Trueform waveform generators (both the 33500B Series and 33600A Series dual-channel units), it is easy to mirror the two signals to create a differential signal. Simply use the inverted tracking capability enabled when the generator is in Dual-Channel Operation mode. This mode may be activated from either the Channel 1 or Channel 2 Output menu.

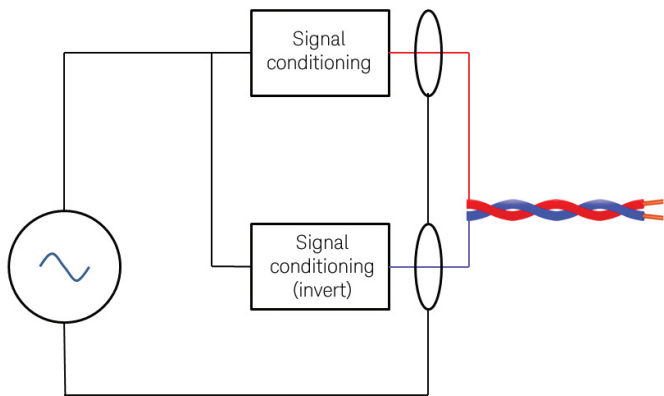

Figure 1. Differential signal block diagram.

The inverted tracking mode causes Channel 2 to be a mirror image of the signal from Channel 1, which is exactly what you need for a differential signal. Once you have this enabled, all you have to do is set up your signal on Channel 1. It will then be automatically inverted on Channel 2, creating your differential signal.

Table 1. 33500B/33600A dual-channel Trueform waveform generators

| 33500B Series Dual-channel models | 33600A Series Dual-channel models |
|--------------------------------------|--------------------------------------|
| 33510B (20 MHz) | 33612A (80 MHz, Arb) |
| 33512B (20 MHz, Arb) | 33622A (120 MHz, Arb) |
| 33520B (30 MHz) | |
| 33522B (30 MHz, Arb) | |

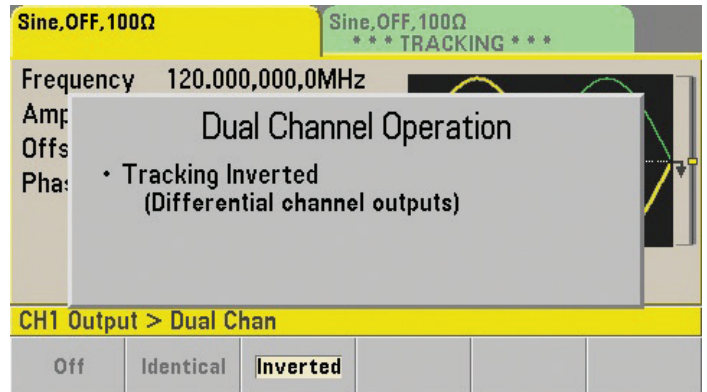

Figure 2. Channel tracking menu.

Measurement tip:

Don't forget to set the load impedance of your output channels. Doing so will enable the generator to accurately determine the voltage output to match your load impedance. Go to **Channel 1 > Output Load** to enter your circuit's load impedance.

Reproduce differential signals from your design

Reproducing the actual signal from your design can help you isolate your test circuit. Using a Trueform waveform generator to perform this task offers a number of key benefits, including the ability to change your signal's frequency, amplitude and offset. With Trueform generators' arb reproduction capability, even glitches from your design are reproduced accurately.

To recreate your signal, first capture it using an oscilloscope with trace saving features. The 33600A Series Trueform waveform generator recreates signals with 1 GSa/s resolution. Modern Keysight scopes can be used to save your signal to a .csv file. Once saved, a USB thumb drive or the 33600A Series' USB drag and drop feature moves the file to your Trueform waveform generator. You can then import the data in the **Waveforms > Arbs** menu. For a differential signal, the data will be a single channel arb. The process above can then be used to recreate the output as a differential signal.

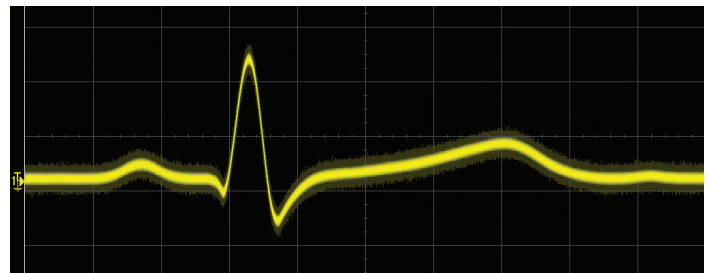

Figure 3. Reproduction of an actual design signal.

Creating a Differential Signal with a Waveform Generator *(continued)*

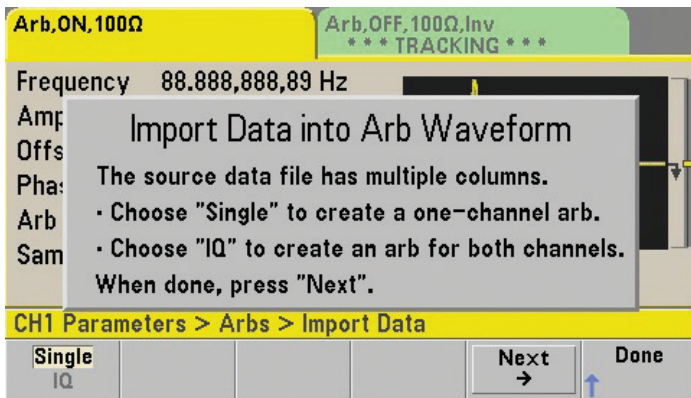

Figure 4. Importing data into an arb waveform.

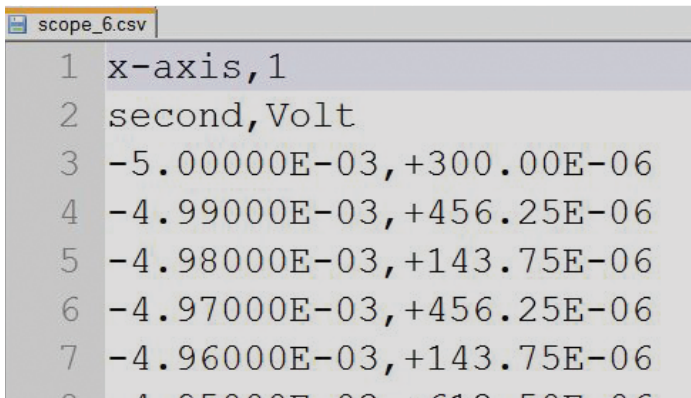

Figure 5. Saving a signal to a .csv file.

Measurement tip:

You can directly output scope trace files if you rename the extension from .csv to .dat files. Trueform waveform generators recognize .dat formats as arb files and can load them without the import data process.

Measurement tip:

If you'd like to design a signal, consider using Keysight's BenchLink Waveform Builder Pro software to build your signals. For more information on the software visit: www.keysight.com/find/33503



Summary

Simulating differential signals can be simple using Trueform waveform generators. You just recreate your own signals with an oscilloscope, capture and then output the data using a Trueform waveform generator. With this process you gain greater flexibility in your signal generation.

See the companion video for this test challenge and get more information at: www.keysight.com/find/trueformTC



For more information on Keysight Technologies' products, applications or services, please contact your local Keysight office. The complete list is available at: www.keysight.com/find/contactus

Americas

| | |
|---------------|------------------|
| Canada | (877) 894 4414 |
| Brazil | 55 11 3351 7010 |
| Mexico | 001 800 254 2440 |
| United States | (800) 829 4444 |

Asia Pacific

| | |
|--------------------|----------------|
| Australia | 1 800 629 485 |
| China | 800 810 0189 |
| Hong Kong | 800 938 693 |
| India | 1 800 112 929 |
| Japan | 0120 (421) 345 |
| Korea | 080 769 0800 |
| Malaysia | 1 800 888 848 |
| Singapore | 1 800 375 8100 |
| Taiwan | 0800 047 866 |
| Other AP Countries | (65) 6375 8100 |

Europe & Middle East

| | |
|----------------|---------------|
| Austria | 0800 001122 |
| Belgium | 0800 58580 |
| Finland | 0800 523252 |
| France | 0805 980333 |
| Germany | 0800 6270999 |
| Ireland | 1800 832700 |
| Israel | 1 809 343051 |
| Italy | 800 599100 |
| Luxembourg | +32 800 58580 |
| Netherlands | 0800 0233200 |
| Russia | 8800 5009286 |
| Spain | 800 000154 |
| Sweden | 0200 882255 |
| Switzerland | 0800 805353 |
| | Opt. 1 (DE) |
| | Opt. 2 (FR) |
| | Opt. 3 (IT) |
| United Kingdom | 0800 0260637 |

For other unlisted countries:
www.keysight.com/find/contactus
 (BP-09-23-14)

See the companion videos for these test challenges and get more information at: www.keysight.com/find/trueformTC

For 33600A Series Trueform waveform generator product information visit: www.keysight.com/find/33600A

myKeysight



www.keysight.com/find/mykeysight
 A personalized view into the information most relevant to you.



www.lxistandard.org
 LAN eXtensions for Instruments puts the power of Ethernet and the Web inside your test systems. Keysight is a founding member of the LXI consortium.



Three-Year Warranty
www.keysight.com/find/ThreeYearWarranty
 Keysight's commitment to superior product quality and lower total cost of ownership. The only test and measurement company with three-year warranty standard on all instruments, worldwide.



Keysight Assurance Plans
www.keysight.com/find/AssurancePlans
 Up to five years of protection and no budgetary surprises to ensure your instruments are operating to specification so you can rely on accurate measurements.



www.keysight.com/go/quality
 Keysight Technologies, Inc.
 DEKRA Certified ISO 9001:2008
 Quality Management System

www.keysight.com/find/trueformTC
www.keysight.com/find/33600A

