

Keysight Technologies

Design and Test Solutions for Advanced Automotive

Accelerate Automotive Design and Test
with Flexible, High-Performance Platforms



Introduction

The automotive industry is moving quickly to proactively adapt the advantages and benefits of electronic engineering. Specifically, wireless, radio frequency (RF), digital, and millimeter wave technologies provide increased safety of passengers and pedestrians, more in-car convenience and entertainment features, as well as, future self-driving and “green” cars.

Two good examples of emerging technologies for increased automotive safety include 360 degree automotive radar which detects any potential risks around a car and helps a driver avoid accidents with advanced emergency braking, blind spot monitoring, lane change assist, adaptive cruise control, parking assist, front and rear cross traffic alert, and more. Secondly, wireless technologies including 802.11p will link each car on the road. These Connected Cars (Car to X) will then share information on road and traffic situations to provide any warning(s) of potential hazards, letting nearby cars take appropriate action.

More and more cars today are applying better telematics and infotainment features for in-car convenience and entertainment services, with higher performance video and audio capabilities, advanced navigation, and in-car wireless hot spot service with high-speed digital automotive communication technologies. These new and existing digital technologies include BroadR-Reach, MOST150, CAN, LIN, and FlexRay, as well as, the wireless technologies of 3G, 4G, Wi-Fi, *Bluetooth*, Near Field Communication (NFC), and more.

The ultimate goal of incorporating various advanced technologies into vehicles is to enable autonomous automobiles to come to fruition more quickly, saving more lives and providing an improved overall driving environment. Both traditional automotive manufacturers and suppliers, as well as electronic-based newcomers are developing self-driving and more environment friendly cars with advanced radar, wireless, navigation system, digital imaging, RF sensors, and advanced electronic power storage technologies.

Applying advanced technologies offers enormous benefits; however, it also brings to the forefront new design and test challenges for developers and manufacturers working in the advanced automotive industry. Based on its 75 years' experience and technical knowledge of RF, millimeter wave, wireless, and high-speed digital design and test, Keysight Technologies, Inc. provides broad and powerful automotive design and test solutions from early R&D to manufacturing stages, helping solve new automotive design and test challenges while you develop and manufacture advanced vehicles designed to save lives.

Testing and Characterizing Automotive Serial Buses

Today's automobiles include a variety of serial buses including I2C, SPI, UART, CAN, LIN, FlexRay, BroadR-Reach, and MOST. Automotive serial buses must be able to operate reliably in the harsh electrical environment of the automobile where random and infrequent transients occur. Keysight Automotive Serial Bus solutions solve challenges of designing and testing your automotive serial buses.

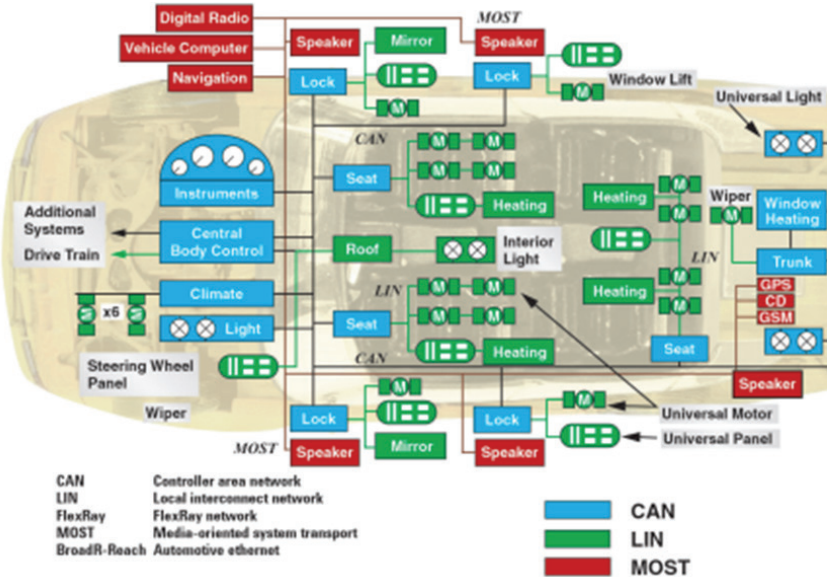

Physical Layer Testing

The primary measurement tools used to test and characterize the physical layer of these buses are oscilloscopes, such as Keysight's InfiniiVision X-Series and Infiniium Series oscilloscopes.

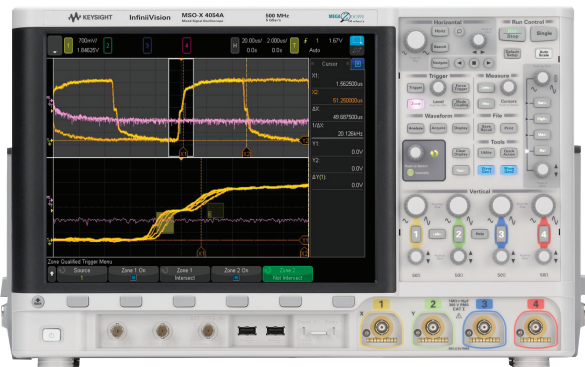

InfiniiVision 4000 X-Series oscilloscope

Serial Protocol Triggering and Decoding

Using an oscilloscope with serial bus protocol triggering and decoding can significantly speed-up the debug process by isolating specific messages of interest for analysis. Keysight's InfiniiVision and Infiniium Series oscilloscopes offer a broad range of protocol-specific options, including the ability to symbolically trigger on and

decode the differential CAN bus, which has been the automobile's "workhorse" serial bus for drive-train and body control for nearly 30 years. In addition, these scopes also support the LIN and FlexRay protocols which are also common in today's automotive designs.



CAN-dbc symbolic trigger and decode

Testing and Characterizing Automotive Serial Buses

Automated Compliance Testing

Considering using high-speed serial buses such as MOST150 or BroadR-Reach/Ethernet? Each industry standards body specifies required tests for physical layer compliancy. For each standard, Keysight's Infiniium oscilloscopes offer fully automated applications that perform 100% testing of physical layer compliancy. The application produces a test report that details the results of each test as well as the overall results.

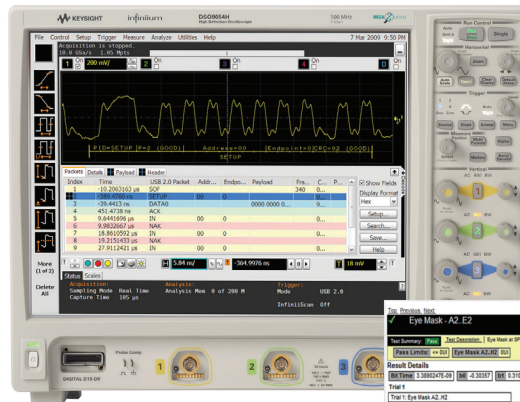

Infiniium oscilloscopes for BroadR-Reach and MOST

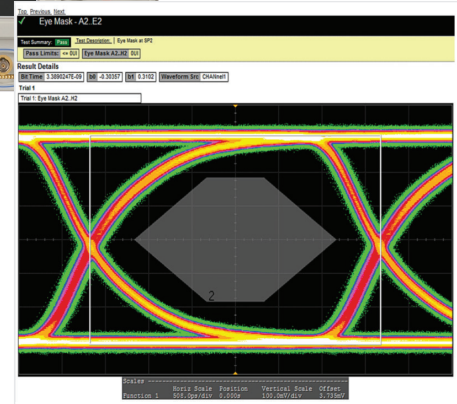

Compliance testing of MOST150 SP2 eye-diagram

Debugging, characterization, validation and reliability testing at temperature

Temperatures, both high and low, affect the performance and reliability of electronic components, assemblies and systems. The temperature extremes that automotive electronics are subject to are some of the most severe in the electronics industry. Measuring the performance of electronic components, assemblies and systems at these extremes with an oscilloscope requires specialized oscilloscope probes that have been designed to perform under these conditions.

N2797A Active Probe	N5450B Cables	N2820A/21A Current Probe
Single-ended	Differential	Current
1.5 GHz	1.5 – 16 GHz	3 MHz
1MΩ input R	50 kΩ input R	nA—A Range
-40 to +85 °C	-55 to +150 °C	-55 to +150 °C

Extreme Temperature Probing solutions

Keysight offers a series of Extreme Temperature Probing solutions for oscilloscope measurements for both voltage and current at temperature ranges up to -55 to +150°C.

Testing and Characterizing Automotive Serial Buses

Pulse Function Arbitrary Generation

One of the key challenges to develop a serial bus receiver is how to build robustness against environmental electrical stress which can include electromagnetic radiation disturbing the communication signal, capacitive loading of cables, the frequency response of connector interfaces or many other cases. The 81160A Pulse Function Arbitrary Noise Generator can simulate potential distortions and deformations in your lab to provide fast and cost-effective verification for your automotive serial buses.



81160A Pulse Function Arbitrary Noise Generator

The Keysight 81160A is a “4-in-1” instrument that can generate pulses, digital patterns, modulated function/arbitrary waveforms and truly random noise signals. With the internal channel addition, it even allows combining signals without external cabling. With two event interfaces (strobe and trigger) per channel, the user has full flexibility in automating the tests. In total, the instrument opens up a huge space of possible test scenarios in the automotive application field. The 81160A is compliant with MOST50 and MOST150, based on the MOST compliance requirements 2V1.

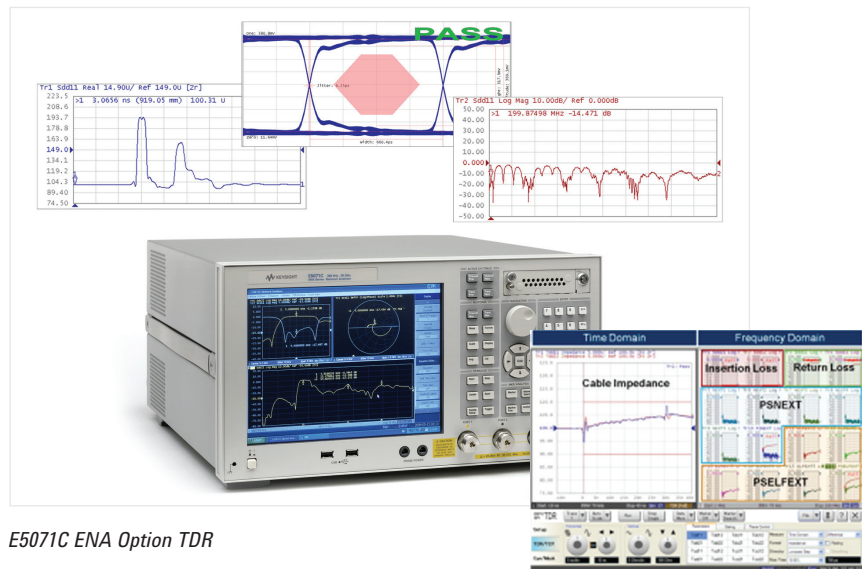

E5071C ENA Option TDR

Cable and Connector Testing

As data rates of automotive systems increase, signal integrity of interconnects drastically affects system performance. Fast and accurate analysis of interconnect performance in both time and frequency domains is critical to ensure reliable system performance. Because managing

multiple test systems becomes difficult, a single test system that can fully characterize differential high speed interconnects is a very powerful tool.

Keysight’s E5071C ENA Option TDR provides an one-box solution for cable and connector testing, including

impedance, S-parameters, and eye diagrams. The ENA Option TDR provides the following three breakthroughs for signal integrity design and verification: simple and intuitive operation, fast and accurate measurements, and high ESD robustness.

Automotive Radar

Applying radar technologies to advanced automotive helps drivers to avoid potential risks from other vehicles, pedestrians and objects on roads and makes self-driving cars possible. The major applications of automotive radars are advanced emergency braking, blind spot monitoring, lane change assist, adaptive cruise control, parking assist, front and rear cross traffic alert, stop-and-go, and more. Keysight provides various automotive radar solutions from design simulation to signal generation and analysis tools.

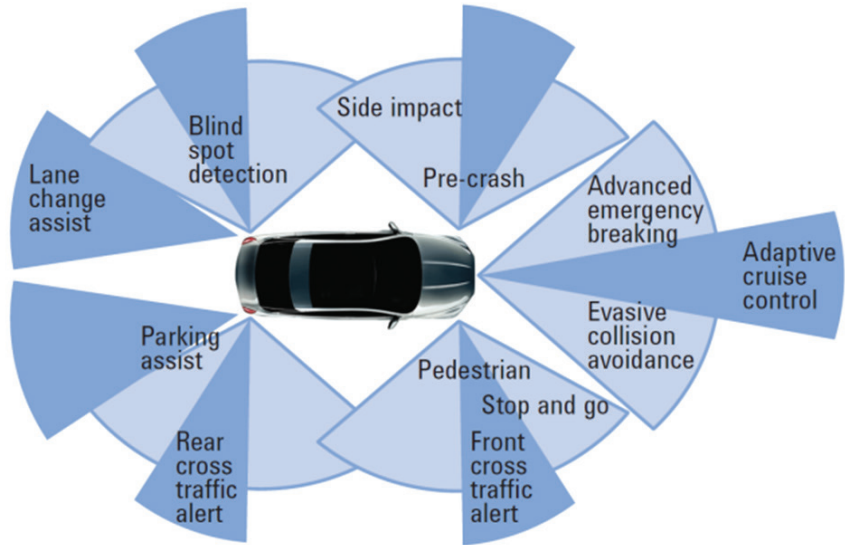

Wideband Signal Analysis Solution

The PXA is extensively used in radar test for a wide range of measurements. Its world class dynamic range allows it to measure lower level emissions while in the presence of larger signals. Combined with a smart mixer the PXA enables pain free measurements up to 110 GHz, or up to THz frequencies using other mixers. Finally the PXA has real-time capability when transient activity needs to be measured.

When ultra-wideband vector measurements are needed, the PXA is a key component of the N9070A solution which enables vector measurements greater than 1 GHz in bandwidth.

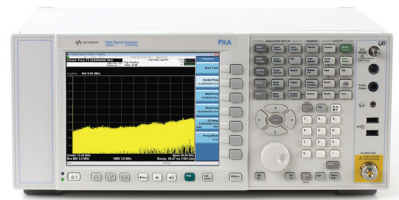
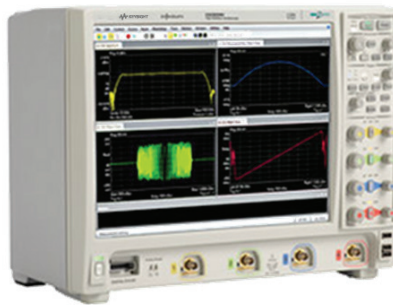

N9070A Wideband Signal Analysis Solution

The N9070A takes advantage of the PXA's wide IF output, the high dynamic range of the Infiniium oscilloscope, and the powerful 89600 VSA software to deliver a wideband high-dynamic range signal analysis solution at an affordable price. Correction data is quickly loaded when the user changes center frequency and span, and the full analysis capability of the 89600 VSA can be used. The corrections contain both amplitude and phase, which enables the 89600 VSA to make accurate wideband measurements such as

analysis of linearity, frequency shift, FM deviation, or virtually any other amplitude and phase parameters.

Key features of the N9070A are automatic loading of correction data from the PXA signal analyzer for > 1 GHz of bandwidth, characterized performance including frequency response and phase linearity up to 800 MHz of bandwidth, high dynamic range scope with up to 12 bits of resolution, and quick setup and measurements.

Automotive Radar

Microwave Analog and Vector Signal Generation

PSG Signal Generators and X-Series Microwave Signal Generators provide microwave frequency signals with basic to advanced functionality, each delivering benchmark performance in its class to automotive radar developers. PSG models offer metrology-grade performance to 67 GHz, with frequency extenders to 1.1 THz. Vector PSG models offer 80 MHz internal modulation bandwidth and 2 GHz bandwidth using an external modulation source, AM, FM, PM, pulse, ASK, FSK, MSK, PSK, QAM and custom I/Q modulations, dual internal function generators for sine, square, triangular, ramp, and noise, and step, list, and ramp sweep frequency and power. Combined with the M8190A wideband arbitrary waveform generator, PSG can generate wide bandwidth signals up to 44 GHz frequency. Additional features of PSG include creating reference signals for radar, multi-tone, NPR, custom modulation, WLAN, GPS/GNSS, MATLAB, and more as well as multi-channel baseband generation, digital I/O, MIMO fading, and RF to RF fading with the N5106A PXB Baseband Generator and Channel Emulator.

The MXG is the pure and precise alternative to the PSG, with advantages in size and speed. It delivers the performance you need--spectral purity, output power, switching speed and more--to perform module- and system-level testing. The benefits of the MXG are generating the signals for radar receiver sensitivity test with best-in-class phase noise and spurious performance,

reducing test stand size with two rack-unit height, maximizing throughput with fast switching speed, creating variable RADAR PRI and pulse width with the integrated pulse train generator. Maximize resources with low cost of ownership, and minimizing downtime and expenses with self-maintenance strategy and low-cost repairs.

Keysight Signal Studio and embedded software is a suite of flexible, easy-to-use, signal creation software that will cut the time to spend on signal simulation. And, with a demonstrated first-to-market track record, Keysight's signal creation software helps you stay at the forefront of product development as wireless systems continue to evolve.



N5183B MXG microwave signal generator

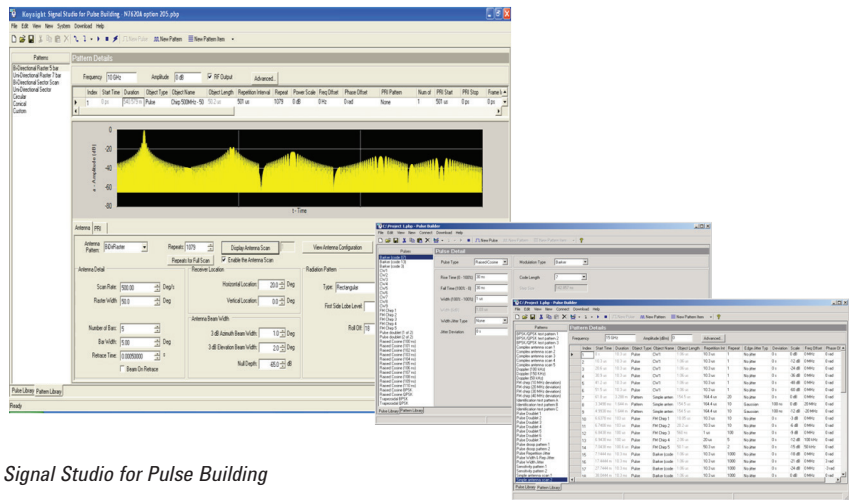

Signal Studio for Pulse Building

Automotive Radar

Radar component characterization and phase noise test

The N5251A Millimeter-Wave Network Analyzer is ideally designed to enable designers of automotive radar components to fully characterize their devices from 10 MHz to 110 GHz in a single measurement. The 4 port configuration, together with the true mode differential application, allows the users to make measurements on the components used in the radar systems. In addition, the fully integrated pulse capability of the system allows users to easily stimulate and measure the response of their device.

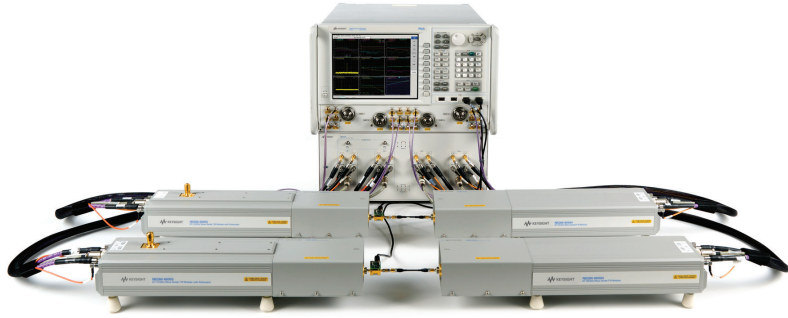

N5251A Millimeter-Wave Network Analyzer

The E5052B Signal Source Analyzer, combined with the E5053A down converter and 11970 series harmonic mixers, is an ideal solution to test the phase noise of free-running VCOs at microwave and millimeter-wave frequencies accurately. Exceptional low phase noise sensitivity and drift signal tracking are achieved up to 110 GHz.

E5052B Signal Source Analyzer with E5053A downconverter plus 11970 Harmonic Mixer



M8190A Wide-band High Performance AWG for flexible automotive radar test and research applications

The frequency band around 79 GHz is proven to be one of the “sweet spots” in terms of atmospheric attenuation. It is located in the middle of the two oxygen absorption peaks. With a modulation bandwidth of up to 4 GHz this band opens a wide area of applications. Today we will find long and short range automotive radars for all kinds of driver assistance systems. Keysight Technologies offers the



M8190A Arbitrary Waveform Generator

M8190A wide band Arbitrary Waveform Generator for signal generation and signal path emulation, and high performance Infiniium series oscilloscopes with Vector Signal Analysis software for the evaluation of captured signals. With Keysight’s M8190A High Performance AWG, the user has all the freedom in crafting the needed waveform. This will be the best choice for a test source for the envisioned application.

Key features of the M8190A Arbitrary Waveform Generator are precision AWG with two DAC settings of 14-bit resolution up to 8 GSa/s and 12-bit resolution up to 12 GSa/s, high-speed arbitrary waveform generation with variable sample rate from 125 MSA/s to 12 GSa/s, spurious-free-dynamic range up to 90 dBc, 2 GSa waveform memory per channel, advanced sequencing, and 5 GHz analog bandwidth.

Automotive Radar

W1905 SystemVue Radar Model Library

The W1905 Radar Model Library saves development time and verification expense in R&D for radar system architects, algorithm developers, and system verifiers. For automotive applications, SystemVue provides Frequency Modulated Continuous Wave (FMCW) system level simulation capability for quick performance evaluation and parameter estimation. SystemVue also allows RF-DSP cross-domain architecture, re-use of custom IP, and integration of models and measurements.

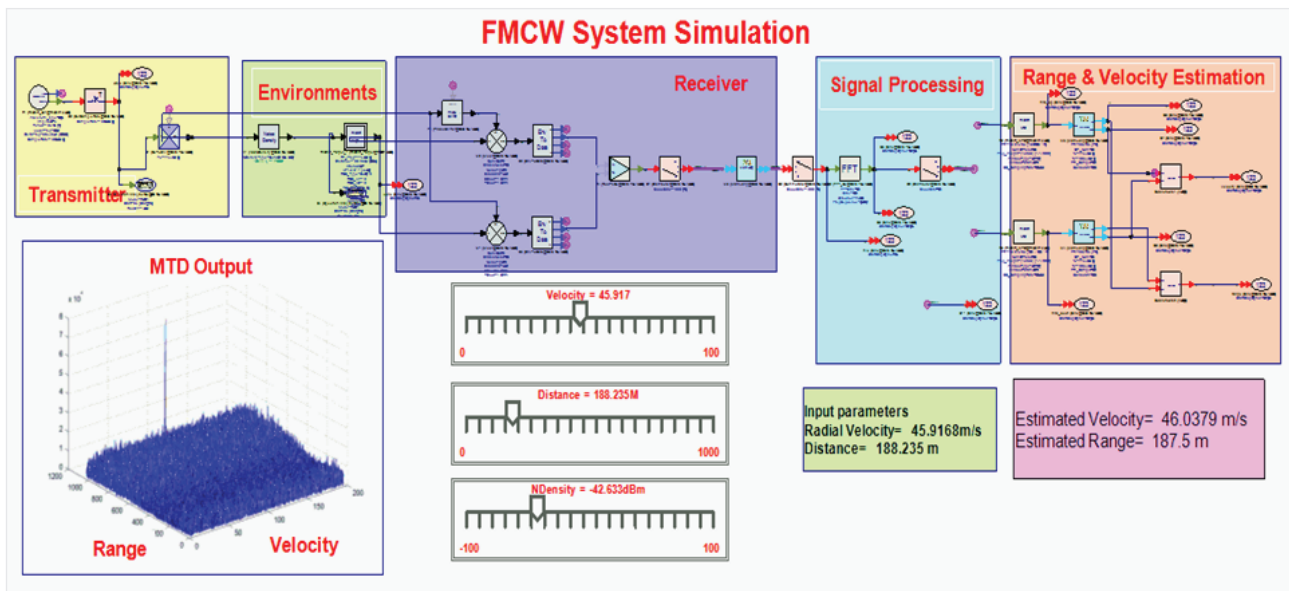

W1905EP SystemVue Radar Model Library

Automotive Radar

76 to 81 GHz Automotive Radar Transceiver Test

Automotive radar applications in the 76 to 81 GHz range have been gaining momentum in the last few years. The radar operating in the E-band spectrum is designed and intended to support various objectives, including adaptive cruise control, blind spot detection, lane departure warning, pre-crash mitigation, and other road safety features. These automotive radar applications can be categorized into three types: short range radar (SRR), middle range radar (MRR), and long range radar (LRR). These radar transceiver modules are installed at various locations on the vehicle. Some transceivers are single-channel or single-port transceivers, while others have a multiple-channel design necessary for using MIMO transmission algorithms. Manufacturers of these transceiver ICs or subsystems are required to measure and validate the maximum radiated power when operating in transmission mode.

Designed with a WR-12 flange connector, the E8486A waveguide power sensor makes precise and direct waveguide measurements in the E-band frequency range and is compatible with most Keysight power meters. A wide dynamic range of -60 to +20 dBm and a SWR performance of 1.06 minimize measurement uncertainty caused by mismatch, providing high accuracy even with low power signals. With the E8486A, get the precision and accuracy you need for E-band applications in a single power sensor.

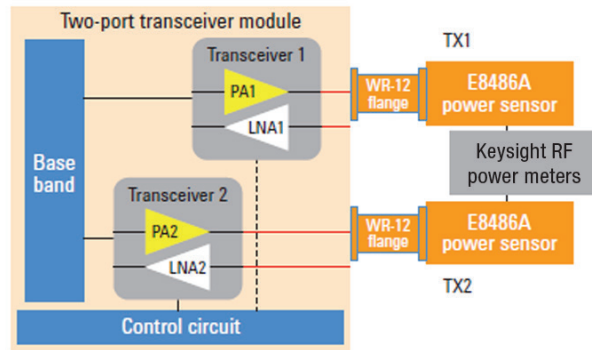
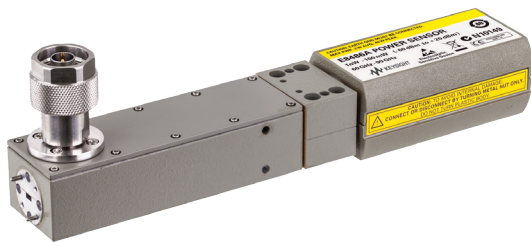

E8486A E-Band Waveguide Power Sensor and radar transceiver module test case

EMI/EMC

N9038A MXE EMI Receiver

Keep your EMI test queue flowing with Keysight's Compliance Receivers and Precompliance Spectrum Analyzers! Working with our Solutions Partners, Keysight provides complete solutions for automotive emissions and immunity testing.

Key Features of Keysight N9038A MXE EMI Receiver

- CISPR 16 and MIL STD compliant
- Fast time domain scanning
- Enhanced built-in EMC measurements
- Advanced diagnostic capability



N9038A MXE EMI Receiver

Does my chassis meet EMI specs?

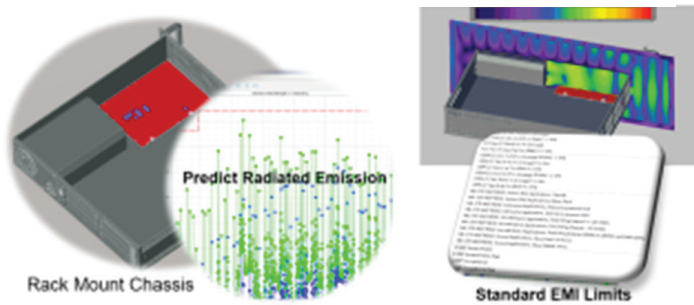

EMPro (Electro-Magnetic Professional)

EMPro offers 3-dimensional full-wave electro-magnetic simulators based on the frequency domain technology, FEM (Finite Element Method) and the time domain technology, FDTD (Finite Difference Time Domain). With these simulation technologies, any arbitrary 3D structures can be simulated, and emission level at any distance, for example, 3 and 10 meters, can be calculated and compared to EMI limits such as FCC or CISPR.

How much CM emission from USTP?

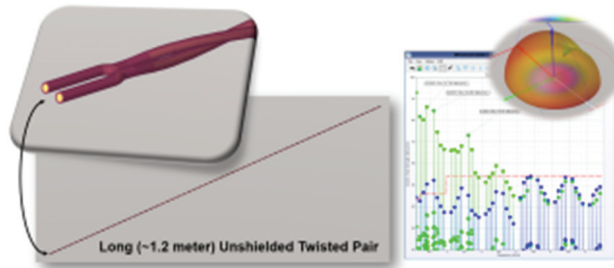

EMPro Application Examples

Wireless Technologies to Connect Cars

More and more advanced vehicles have wireless connections and these Connected Cars (Car-to-X) will improve safety, security, performance, reliability and infotainment. Automotive designers and developers need to verify various types of wireless technologies including 2G, 3G and 4G LTE and LTE-Advanced cellular, WLAN, Bluetooth, Near Field Communication (NFC), and more to guarantee the safety and the performance of the Connected Cars.

N9030A PXA high-performance or N9020A MXA mid-range signal analyzer with real-time spectrum analysis (RTSA) capability

The Keysight X-Series signal analyzers are powerful tools to help you achieve the highest quality RF design and be “first-to-market” with your product.

For in-vehicle RF system R&D, the PXA offers the most advanced performance for those “must-have” measurements such as phase noise and demodulation, covering frequencies up to 50 GHz or beyond. It also provides one-button measurements for various cellular communications and wireless connectivity

standards. The upgradable RTSA with up to 160-MHz real-time bandwidth effectively characterizes time-varying signal spectra for applications such as troubleshooting frequency hopping signals used in Bluetooth tire pressure sensing. The mid-range MXA, with the same user interface, measurement applications, and RTSA features as the PXA, offers an alternative solution at a lower price point to best fit your budgetary constraints for design verification and manufacturing.

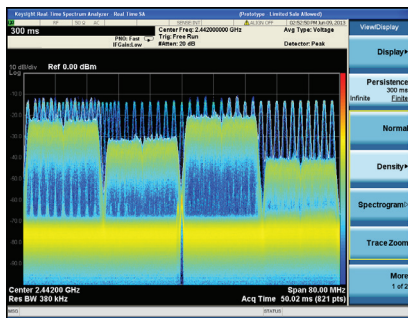

RTSA display with PXA/MXA helps visualize the multi-burst signals of WLAN and Bluetooth.



N9030A PXA Performance Signal Analyzer with RTSA, ideal for your R&D environment



N9020A MXA Mid-range signal analyzer provides the best value for your design verification

Wireless Technologies to Connect Cars

WLAN (802.11 a/b/g/p/n/ac) Signal Generation and Analysis

The N7617B Signal Studio for WLAN 802.11a/b/g/n/ac creates waveform files for use with Keysight's RF vector signal generators such as the N5182B MXG for testing of WLAN receivers that are being integrated into automobiles to provide wireless data connections for passenger use.

WLAN transmitters can be tested with the N9077A WLAN Measurement application and the N9020A MXA or N9030A PXA signal analyzer. This application provides measurements such as channel power and spectrum mask as well as modulation analysis results such as EVM, with limit lines and pass/fail results.

Both of these WLAN applications also support the 802.11p standard for vehicle-to-vehicle or vehicle-to-infrastructure communications.

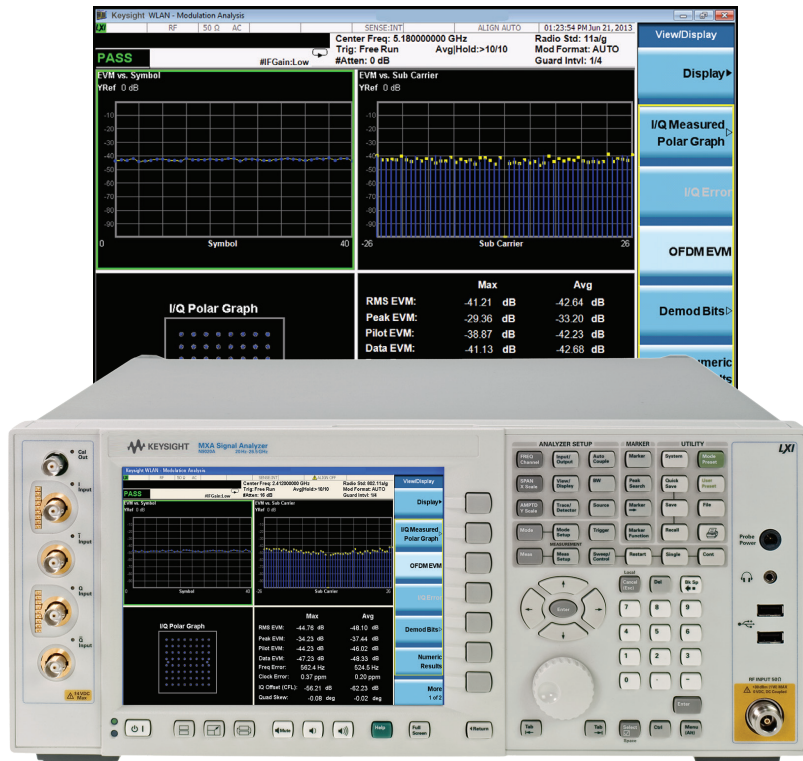
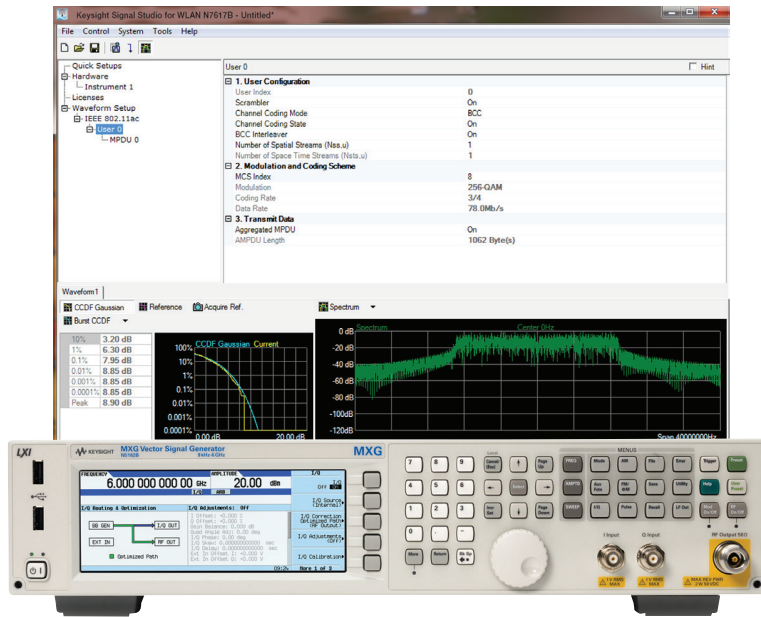

Signal Studio and MXG Signal Generator and embedded signal analysis application on X-Series Signal Analyzer

Wireless Technologies to Connect Cars

Cellular and Wireless Connectivity Test Sets

From development to high-volume production of wireless modules and devices equipped in advanced vehicles, Keysight one-box test solutions deliver fast measurement speeds, repeatable accuracy, and exceptional flexibility for testing today's and future wireless technologies in the automotive industry. That translates to lower costs and increased profit margins for your company. There's a Keysight solution for testing all major wireless technologies and wireless connectivity formats including: LTE-Advanced, LTE FDD/TDD, GSM/GPRS/EGPRS/E-EDGE, W-CDMA/HSPA/HSPA+/DC-HSDPA, cdma2000/1xEV-DO/eHRPD, TD-SCDMA/TD-HSDPA/TD-HSUPA, *Bluetooth* including EDR and Low Energy, ZigBee, WLAN, and WiMAX.

N4010A wireless connectivity test set... helps advanced automotive developers and manufacturers to test multiple wireless connectivity technologies including WLAN 802.11 a/b/g/n, *Bluetooth* and Zigbee with one test platform, and increase manufacturing throughput with fast, accurate measurements. Using with N4011A MIMO/Multi-port Adapter, automotive wireless device developers can test WLAN MIMO (up to 4x4) devices and modules. Also, N4010A provides a broad range of measurements for evaluating wireless formats in the 2.4 GHz or 5 GHz bands using with the Keysight 89600 Vector Signal Analysis software or N4018C/19C *Bluetooth*/WLAN Wireless Test Manager software.

E6640A EXM Wireless Test Set... drives down the cost of capital equipment by optimizing multi-device testing with up to four TRX channels, each covering up to 6 GHz with 160 MHz bandwidth, with two full-duplex and two half-duplex ports per TRX. The test set is customizable to connect up to 32 DUTs with multi-port adapter (MPA) technology. It's scalable to meet your production needs for today's and future wireless technologies including LTE-Advanced, LTE FDD, LTE TDD, HSPA+, W-CDMA, 1xEV-DO, cdma2000, GSM/EDGE-Evo, TD-SCDMA, 802.11ac, 802.11a/b/g/n, WLAN MIMO, *Bluetooth*, multi-satellite GNSS, and digital video in one-box.



E6640A EXM Wireless Test Set for Wireless Manufacturing

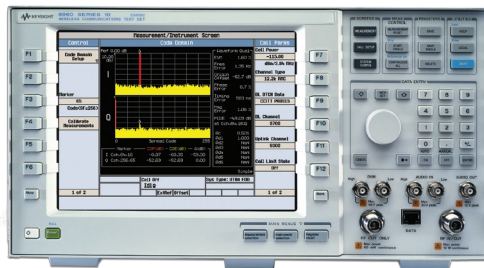

E5515 8960 Series 10 Wireless Communication Test Set



N4010A Wireless Connectivity Test Set with N4011A MIMO/Multi-Port Adapter

Wireless Technologies to Connect Cars

E7515A UXM Wireless Test Set ...

is a highly-integrated signaling test set created for functional and RF design validation in next generation in-car wireless communication and beyond. It provides the integrated capabilities you need to test the latest designs, delivering LTE-Advanced category 6 now and handling more complex requirements later. You will be ready for 4G and beyond with UXM's multi-format capable platform that will handle the next advancements in antenna techniques, component carriers, and data rates. The extensible architecture includes high-speed interconnects, upgradable processors, expansion slots, and versatile display capabilities with 15-inch touch screen interface.

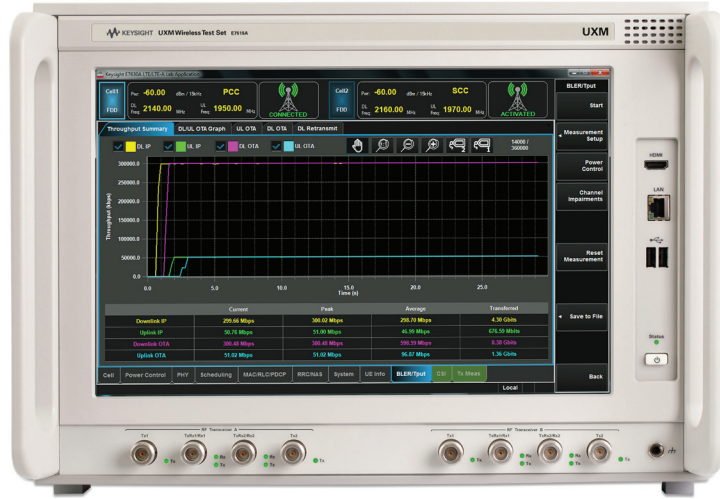

E7515A UXM Wireless Test Set

Near Field Communication (NFC)...

is a fusion technology that provides new valuable service to the users by integrating RFID Technology with Mobile Communication devices & Wireless Internet infrastructure, provides various benefits to various wireless connections in automotive industries.

T3111SNFC
Conformance
Test System

- NFC & RFID devices emulator
- Users can build their own test cases
- Automated test cases execution

- Validated tool for NFC forum certification program
- RF and protocol testing in one single instrument
- Onebox test solution no need for external instrumentation
- Robots supported



T3121S NFC
R&D Test System

Wireless Technologies to Connect Cars

High Efficiency, Low cost RF testing solution for Automotive TPMS, RKE/PKE applications

The key challenge we address with our RF test solution is testing the RF transceivers used in tire-pressure monitoring system (TPMS), or the remote keyless entry (RKE) and passive keyless entry (PKE). Testing items include: center frequency, power and FSK deviation for the transmitters, and the sensitivity test for the receivers.

These RF devices adopt ASK/FSK modulation and work in ISM bands (such as 315 MHz, 433 MHz), and they enable low power, high performance RF communications between themselves and the ECUs of the vehicles, yet remain with long battery life.

Using an efficient and reliable testing solution helps you ramp up volume manufacturing and deliver products with proven quality, and helps you save time and money. Accelerate RF analysis, and yet hold your budget!

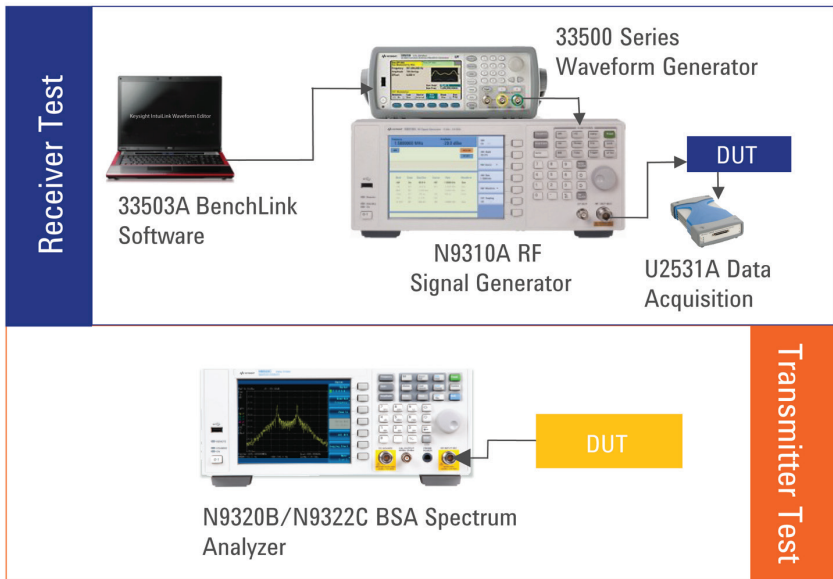

Equipment setups for Receiver and Transmitter Tests

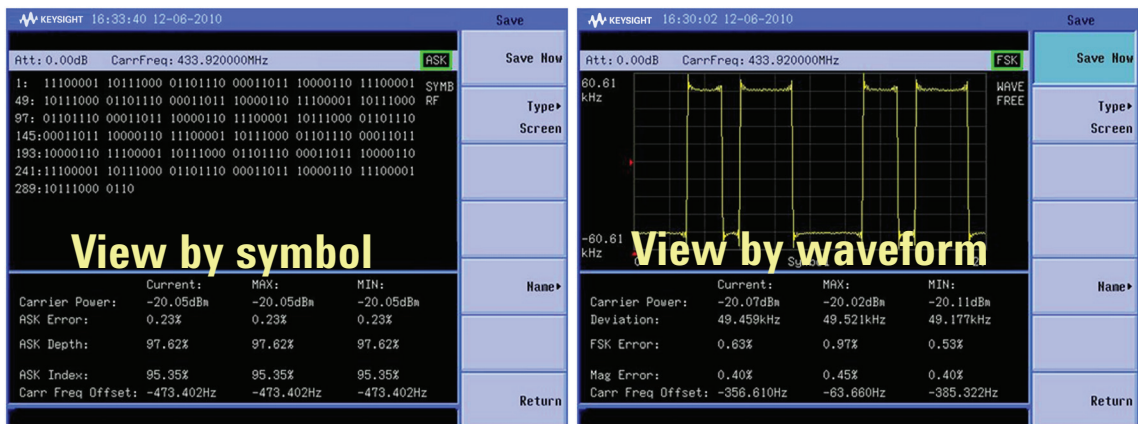

N9320B/N9322C spectrum analyzer provides one-button FSK signal analysis with symbol and waveform view maps

Automotive DC Power Analysis

DC Power for Design Test with N6705B DC Power Analyzer for 50-500W

Motors and solenoids cause vehicle power system voltage transients and dropouts. Vehicle electronics require adequate power transient immunity, and their mission-critical nature requires thorough testing of ECUs, electro-mechanical components, infotainment, and telematics. You can use ISO standard transient waveforms to test your systems, or capture actual transients as they occur in the vehicle and play them back in your DC power transient testing.

Use the N6705B to set up a variety of DC transient tests to run on your own bench. Transient waveforms on 50 – 500 W DC power outputs are easy to create using the built-in arbitrary waveform generator through the intuitive front panel display. You can sequence built-in and custom waveform segments, repeat segments as desired, and quickly modify your waveforms as you cycle through design iterations.

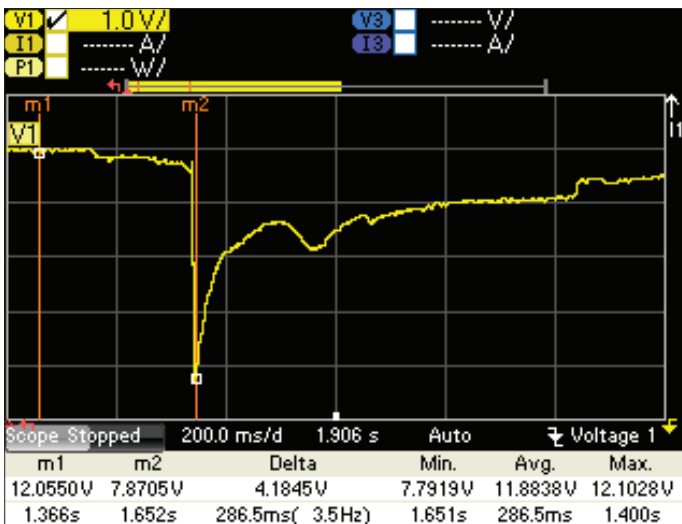

Power supply reset test waveform profile created with N6705B. Engine crank profile on DC power system in-vehicle captured with a digitizing oscilloscope and easily loaded into the N6705B DC Power Analyzer to define the transient output of the DC Supply

Automotive DC Power Analysis

Advanced Power System for 500-2000W DC Power and Transient Testing

Use the Advanced Power System family of high-performance DC supplies to apply stimulus up to 2000 W or up to 200 A for your most demanding higher-power testing applications. Extremely fast up- and down-programming speeds improve your production test productivity. Built-in precision digitizing capability allows you to measure turn-on currents. The APS accurately sources low-level standby currents and then quickly responds to sudden load changes requiring tens or hundreds of amperes. Define arbitrary waveforms at high power levels to simulate engine cranking and other transients.

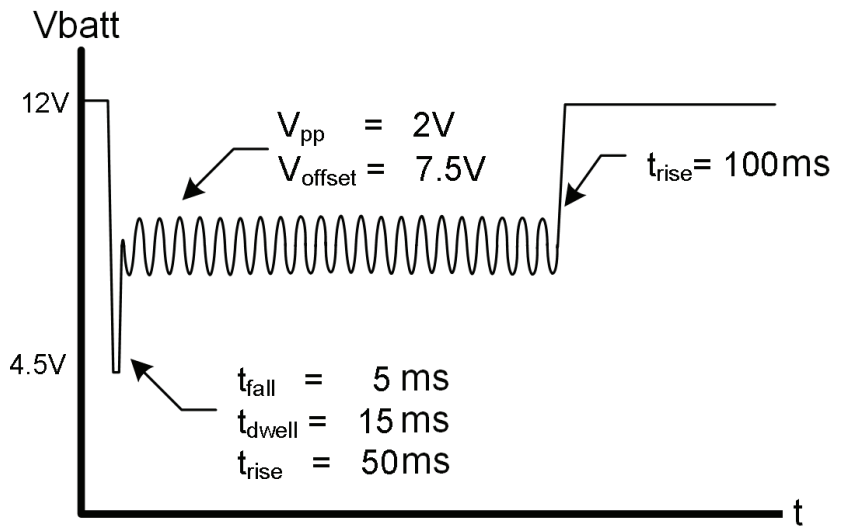

N6900/N7900 Advanced Power System

Automotive DC Power Analysis

DC Power for Life & Durability Testing

Life and durability testing is critical to vehicle system reliability. DC Power Supplies and Electronic Loads are fundamental to productive and meaningful life testing.

Keysight DC power supplies ranging from 50W to 60 kW give you reliable, stable power for your DUTs during life testing. Modular electronic loads allow you to mix and match loads to match the requirements of each DUT. Keysight eLoads quickly step through sequences of load settings and measure load voltages and currents.



N8900 Series Autoranging DC Supplies provide 5 kW – 60 kW at up to 1500V and up to 510 A



N3300 Series Loads can be configured with load modules ranging from 150 – 600 W

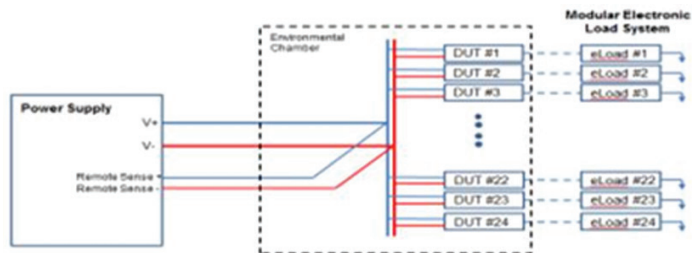

Advanced Multi-Channel Car Infotainment System Test

Today, the majority of automotive audio devices have more than two channels, from six channels (5.1) in surround sound applications to 16 or more channels. The conventional solution for testing multiple channels with a two channel audio analyzer requires add-on switchers which are slow and inaccurate. As only one or two channels are being observed at a time, designers and manufacturers are often blind to interactions between channels, and they may miss seeing output clipping in channels during full power output tests as well as phase and crosstalk interactions, particularly the complexity of all the output channels interacting with each other. Besides, current and future car radio infotainment systems consist of wireless connectivity, GPS, display, and more, and this will make manufacturers face various challenges to test all of these parameters while maintaining low manufacturing cost.

Make multi-functional and higher performance audio measurements with the U8903B audio analyzer. The next generation of the U8903A, the new U8903B comes with added POLQA capability in addition to two-channel wideband analog generator and analyzer functions. Test ultra-low distortion devices with a low residual distortion of <-110 dB, and accurately measure harmonics and noise over 1.5 MHz with the U8903B's wide measurement bandwidth. With the U8903B audio analyzer, you get an audio test solution that is configurable to meet your specific audio application needs. The key features of U8903B audio analyzer are analog audio test up to 1.5 MHz measurement bandwidth, 2 to 8 configurable analog channels, less than 110 dB residual distortion, speech quality test including POLQA (Perceptual Objective Listening Quality Analysis) and PESQ (Perceptual Evaluation of Speech Quality), automatic test sequence, USB control interface and recording/playback mode.



U8903B Performance Audio Analyzer

Automotive Functional Test

Automotive Functional Test System with PXI Solutions

Electronic control modules in a vehicle require adequate measurement accuracy, high power input and high power rating load simulation. Keysight's TS-8989 one box system solution targeted for automotive ECU test consists of high current switch/load, PXI controller & instrumentation, test executive software and development tools.

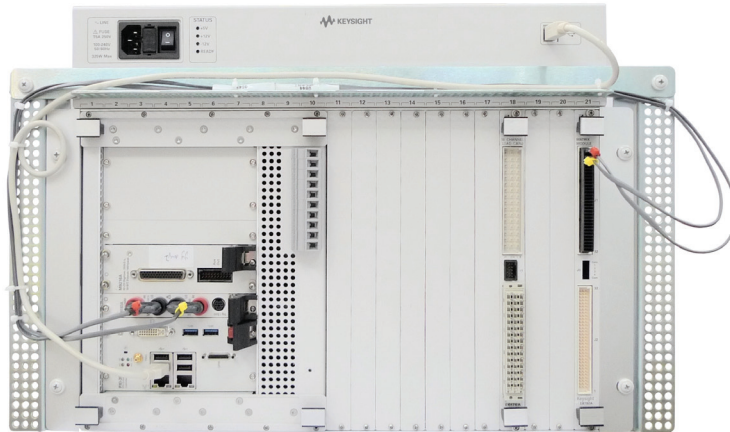

TS-8989 PXI Functional Test System

The system is capable of handling up to 104 test points and 40A current, providing a cost effective solution to low to medium pin automotive products.

TS8989 simple Body Control Modules (BCM)...

The BCM is responsible for monitoring and controlling various electronic accessories in a vehicle's body. It controls the power windows, lamps, air conditioning, central locking, washer motor and many other functions. In order to emulate the specific body control, test engineers can choose the appropriate internal/external passive load devices from TS8989 family load cards. For example, a 10 A rating resistive load is needed to represent the effect of a power window motor. Following with voltage/current measurement of functionality check, the load is connected to a high speed, high accuracy PXI digital multi-meter (DMM) through switching matrix.

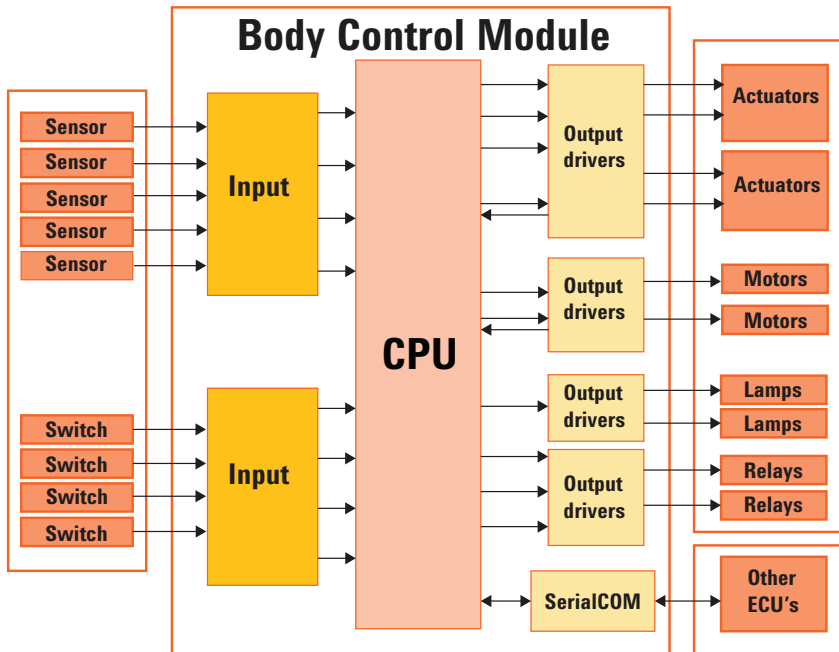

A typical simple 40-pins BCM test setup requires high current 30A load cards for power switching, 7.5A load card with fly back protection for load switching, 40x4 matrix for I/O switch-

ing, and a high speed DMM for rapid mode changes between resistance, voltage and current measurements which TS8989 provides all in a one box environment.

Automotive Functional Test

Automotive Electronic Testing...

Testing the automotive electronic control unit (ECU) is all about applying the right stimulus and measuring the precise output. Keysight has the right selection of PXI modules for up to 100V of input and up to 250V of measurement. This eliminates the needs of having external amplifying circuitry as signal conditioning for both the analog input and digital input to the ECU.



M91xxx Family of Automotive PXI Test Instruments

In addition, the most common challenging measurement for the engine control module is measuring the injector output which involves the flyback circuitry. The flyback voltage can shoot as high as ~200V. In manufacturing testing, it is important to capture both the voltages at all stages and the time taken for each voltage to happen.

As such, Keysight's PXI modules for Automotive Electronics Testing are the right solution, providing the right voltage levels without the need for external amplifying circuits.

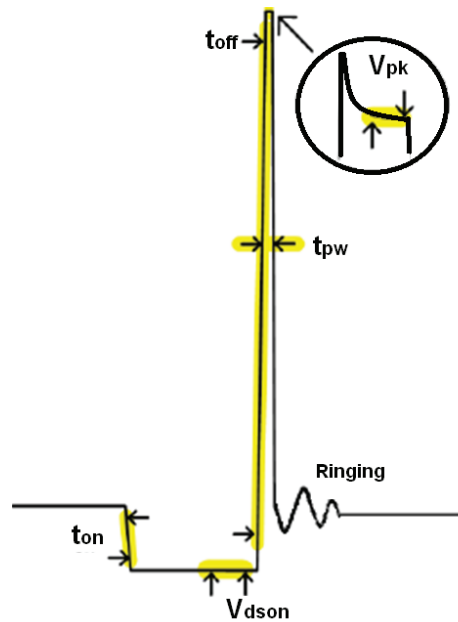
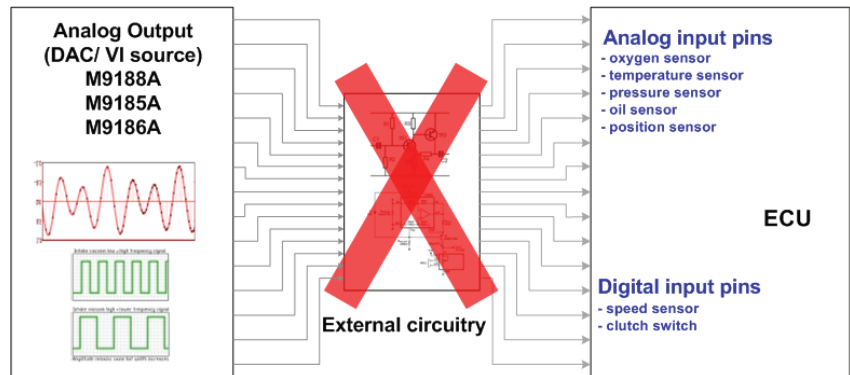

Automotive Functional Test

Automotive Data Acquisition and Electronic Functional Test with the 34980A Multifunction Switch/Measurement System

The 34980A is an expandable and reconfigurable mainframe with a built-in DMM which offers a selection of 21 switch, measurement and control modules. Of its many uses, it is often found in automotive applications for data acquisition and production test in ATE/functional test systems.

For automotive engine test, the 34980A and multiplexer switch modules are used to accurately and quickly measure a large number of physical parameters, such as temperature, oil pressure, fuel flow, RPM and exhaust composition. The 34980A also provides engine control including engine shutdown in cases where critical limits are reached. Data acquired by the 34980A can be analyzed on standard computer systems.

Every Electronic Braking Control Unit (EBCU) module is electronically tested for possible brake failure during the production process. The 34980A provides the central switching of the test system. Matrix switch modules are used to connect stimulus signals from various instruments and loads to the EBCU module test points, and to measure results with the speed, flexibility and the performance required to handle these complicated tests.



Multi Function Switch/Measurement Unit

Navigation Systems

Navigations systems are available in many automobiles to guide drivers to their destinations, and location information is also used in systems like eCall to alert emergency centers to the vehicle's location. The core of these systems are the navigation receivers that make use of signals from one or more global navigation satellite systems such as GPS, GLONASS, and Beidou. Verification of these receivers can be performed by using simulated satellite signals to test for time to first location fix, receiver sensitivity, and location accuracy.

For R&D and design verification, the N7609B Signal Studio for GNSS software can be used with the N5172B EXG or N5182B MXG signal generators to provide real-time simulation of multi-satellite signals from the GPS, SBAS/QZSS, GLONASS, Galileo, and Beidou systems. This solution provides up to 40 channels for any combination of GPS, SBAS/QZSS or GLONASS line-of-sight and multipath signals, with 16 additional channels to support Galileo. Real-time impairments such as multipath and pseudorange errors can be added.

For manufacturing test, the N7609B also offers a basic mode option that generates arbitrary waveform files that simulate single or multi-satellite signals for short periods of time. These waveform files are compatible with many Keysight RF vector signal generators, including PXI modules and wireless test sets.

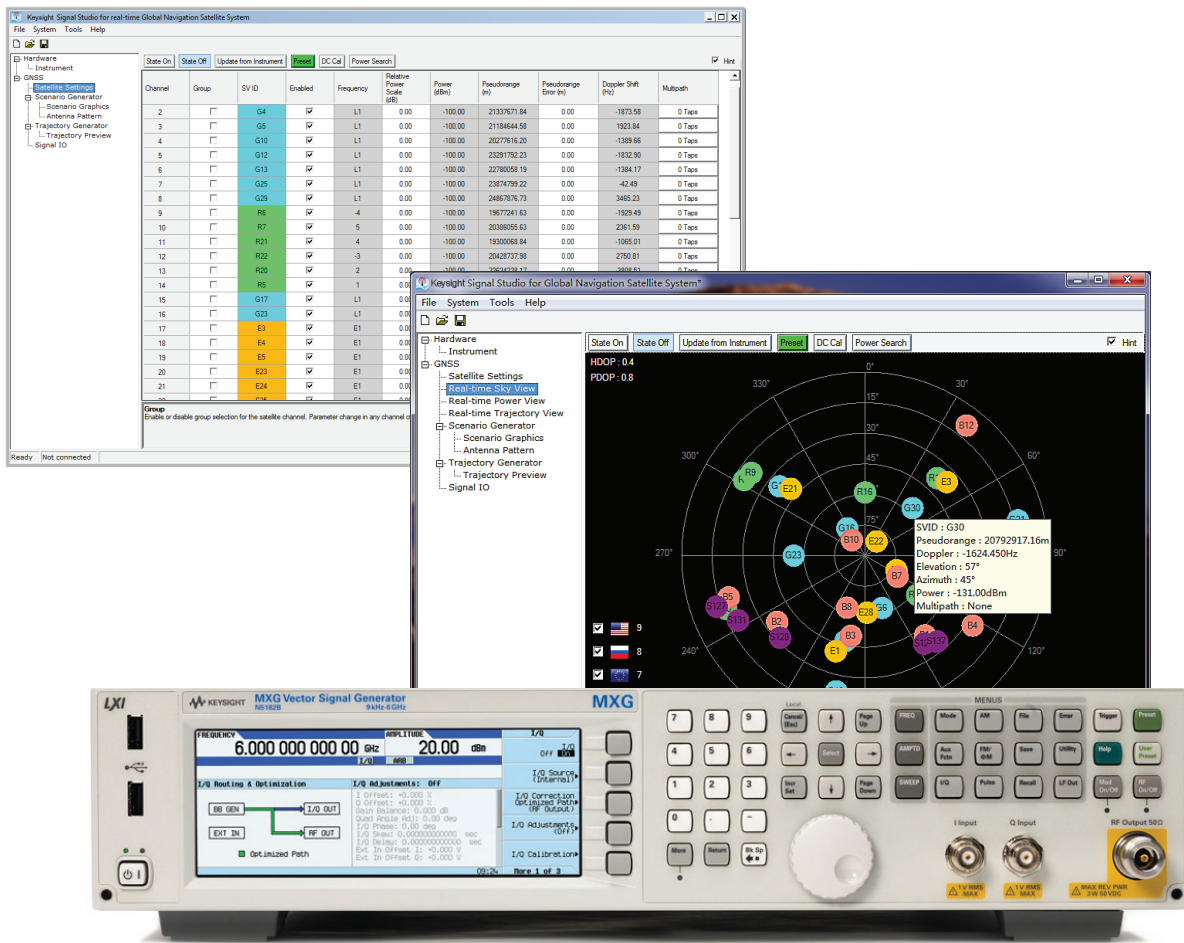

Real-time GNSS simulation using N7609B and MXG signal generator

RF HandHeld Instrument

Electronic measurements are not only required on your bench. Keysight's FieldFox and N934x HSA handheld RF and microwave analyzers make it easier to do the evaluation in or around assembled cars. HSA meets CISPR Class A requirements and FieldFox meets CISPR Class B, making them ideal for checking EMI problems.

Many systems on board must be designed and tested to eliminate interference. The FieldFox and N934x HSA analyzers offer portable spectrum analysis to help users identify the source of interference from the module level to the assembled car.

In addition to spectrum analysis, FieldFox provides precision measurements as a cable and antenna tester, vector network analyzer, power meter, independent signal generator, vector voltmeter, and variable DC source. The network analyzer function enables you to measure the isolation between inside and outside the vehicle, and evaluate the return loss of antennas such as radio, cell band, GPS and tire pressure sensor antennas.

The N934x HSA analyzers offer essential measurement features in a value package. It is the only handheld analyzer that can analyze ASK/FSK modulation, which is widely used in

Tire Pressure Monitoring Systems (TPMS), and Remote Keyless and Passive Keyless Entry (RKE and PKE) systems.

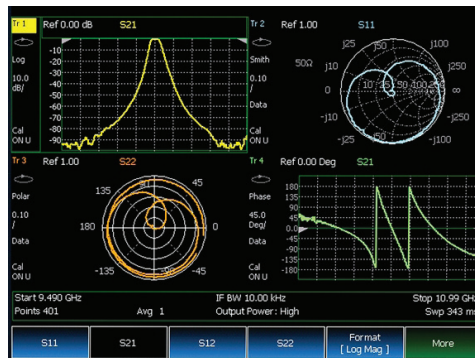

FieldFox analyzers integrate the microwave capabilities of ten instruments into a single, compact and lightweight instrument

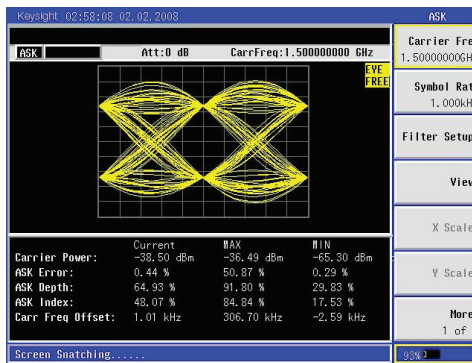

N934x HSA analyzers offer great value and ASK/FSK demodulation

Automotive In-Circuit Test

Automotive Fuse Box Testing

The i1000D In-circuit Test System now features new digital capabilities, including digital PCF/VCL library based testing, Boundary Scan and I²C/SPI serial programming on a simple, low-cost test fixture. This presents an excellent opportunity for customers who are looking for better test coverage without any increase in cost.

Fuse Box Testing in the i1000D is applicable to both High Voltage and High Current measurements. The test methodology is integrated into the standard window based programming sequence. It safeguards against fixture relays of up to 1A and is able to drive voltages of up to 150V during testing. All safeguards are built into the system, which can be controlled automatically by the programmers.

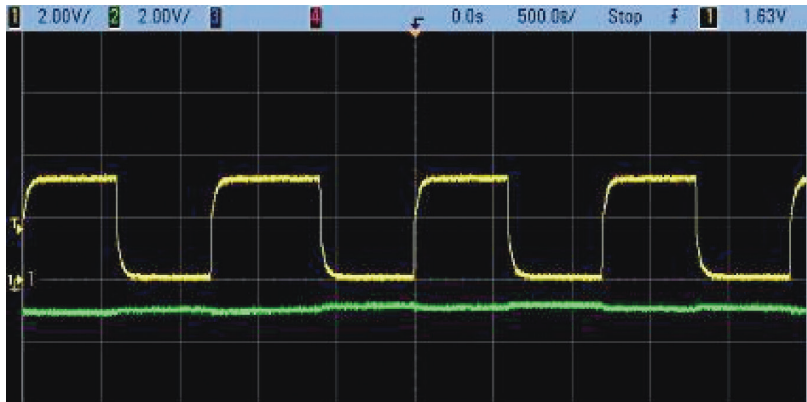

No cross talk on adjacent channels



Low signal loss



i1000D Small Footprint Inline In-Circuit Test System

Automotive In-Circuit Test

Fully Automated Manufacturing Test with i3070 Series 5i Inline In-Circuit Test System

The i3070 Series 5i System is designed to bring all the industry-leading ICT technologies into your fully automated manufacturing line with a full suite of award-winning ICT solutions: short-wire-fixture technology ensures transportability, reliability and stability, and innovative design ensures easy maintenance and fixture change.



i3070 Series 5i Inline In-Circuit Test System

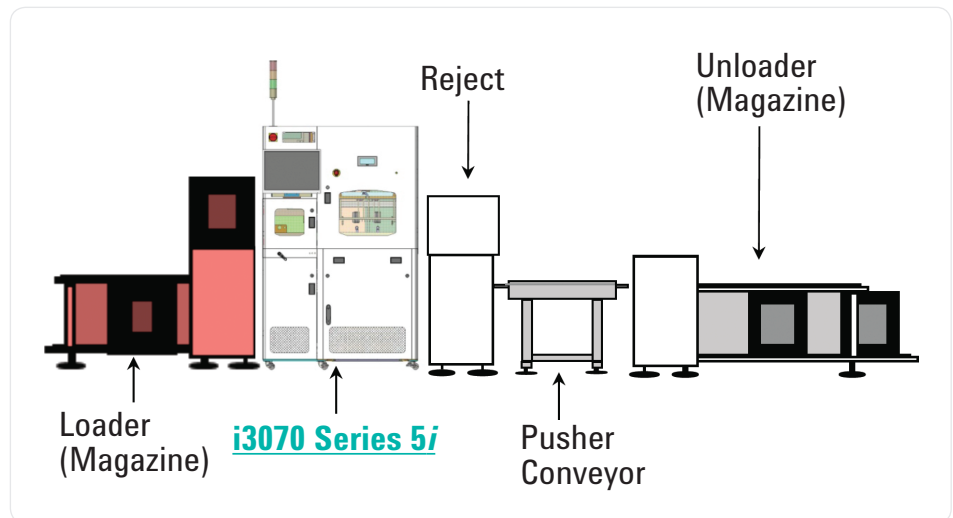

Island Mode Deployment Example

Automotive In-Circuit Test

Addressing Current and Future Boundary Scan Needs

Keysight x1149 Boundary Scan Analyzer is a printed circuit board tester in compliance with the IEEE 1149.1 Standard test access port (TAP) and boundary scan architecture. The Keysight x1149 offers an easy to use software interface for development, debug and production runtime.

The x1149 Boundary Scan Analyzer has a simple, easy and efficient GUI which provides flexible and convenient

screen information management. It has a built-in CAD translation tool and uses the i3070 board file for test generation. The debugged test and library can be reused throughout the entire product life cycle. The advantages include TCK signal fidelity, which ensures test transportability, repeatability and stability. Production-friendly pin-level failure reports save diagnostic time. Program CPLD/FPGA using STAPL, SVF, JAM and JBC.

In-System programming uses HEX, S-records and binary files.

The x1149 Scan Path linker lowers your cost of ownership by increasing interconnect nets coverage. It also comes with Keysight's Cover-Extended Technology that combines Boundary Scan with capacitive-coupled sensing technology, based on Vectorless Test Extended Performance (VTEP) technology.

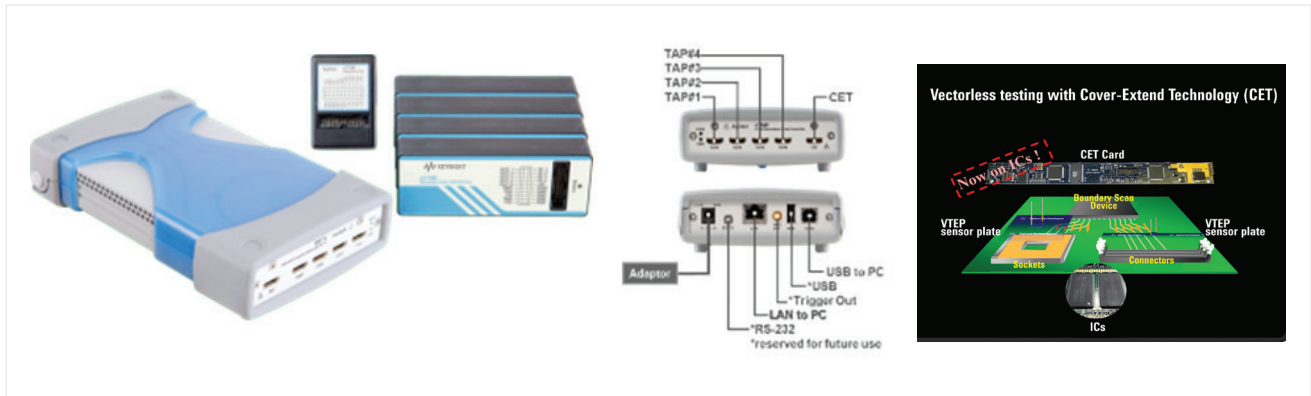

X1149 Boundary Scan Analyzer and Cover-Extend Technology

Accelerate Automotive Design and Test with Flexible, High-Performance Platforms

Design and Development

Keysight design and development tools help you verify your automotive devices even before having prototypes. We are determined never to let test equipment needs stand in your way of developing innovative products for evolving automotive device design and development.

Integration and Interoperability

Keysight provides test equipment to help ensure your automotive devices will integrate and interoperate with other devices. Keysight also provides tools and services to streamline the way you prepare for certification, helping you evaluate module performance, characterize interoperability, and make sure your integration efforts result in certified products.

Design Verification and Conformance

Keysight offers pre-conformance and design-validation test systems built around our test tools. Keysight's test solutions let you check your new products against requirements so you can determine if your automotive products will be allowed to operate in the defined geographic regions.

Manufacturing

Keysight extends its expertise to offer stand-alone products and system solutions to help get your automotive device designs to market faster and more efficiently.

Service and Maintenance

Keysight's tools allow you to do more in the field in less time and increase your ability to detect and eliminate interfering signals among automotive devices used today in cars around the world.

For Additional Information

www.keysight.com/find/SA
www.keysight.com/find/SG
www.keysight.com/find/SSA
www.keysight.com/find/Scope
www.keysight.com/find/NA
www.keysight.com/find/mmWave
www.keysight.com/find/FieldFox
www.keysight.com/find/HSA

www.keysight.com/find/Modular
www.keysight.com/find/EXM
www.keysight.com/find/EMI
www.keysight.com/find/Power
www.keysight.com/find/ICT
www.keysight.com/find/AudioAnalyzer

myKeysight

myKeysight

www.keysight.com/find/mykeysight

A personalized view into the information most relevant to you.



www.axistandard.org

AdvancedTCA® Extensions for Instrumentation and Test (AXIe) is an open standard that extends the AdvancedTCA for general purpose and semiconductor test. Keysight is a founding member of the AXIe consortium. ATCA®, AdvancedTCA®, and the ATCA logo are registered US trademarks of the PCI Industrial Computer Manufacturers Group.



www.lxistandard.org

LAN eXtensions for Instruments puts the power of Ethernet and the Web inside your test systems. Keysight is a founding member of the LXI consortium.



www.pxisa.org

PCI eXtensions for Instrumentation (PXI) modular instrumentation delivers a rugged, PC-based high-performance measurement and automation system.



Three-Year Warranty

www.keysight.com/find/ThreeYearWarranty

Keysight's commitment to superior product quality and lower total cost of ownership. The only test and measurement company with three-year warranty standard on all instruments, worldwide.



Keysight Assurance Plans

www.keysight.com/find/AssurancePlans

Up to five years of protection and no budgetary surprises to ensure your instruments are operating to specification so you can rely on accurate measurements.



www.keysight.com/go/quality

Keysight Technologies, Inc.
DEKRA Certified ISO 9001:2008
Quality Management System

Keysight Channel Partners

www.keysight.com/find/channelpartners

Get the best of both worlds: Keysight's measurement expertise and product breadth, combined with channel partner convenience.

"WiMAX," "Fixed WiMAX," "Mobile WiMAX," "WiMAX Forum," the WiMAX Forum logo, "WiMAX Forum Certified," and the WiMAX Forum Certified logo are trademarks of the WiMAX Forum.

The word **Bluetooth** and it's logo are U.S. registered trademarks of **Bluetooth SIG**.

www.keysight.com/find/wirelessconnectivity

For more information on Keysight Technologies' products, applications or services, please contact your local Keysight office. The complete list is available at: www.keysight.com/find/contactus

Americas

Canada	(877) 894 4414
Brazil	55 11 3351 7010
Mexico	001 800 254 2440
United States	(800) 829 4444

Asia Pacific

Australia	1 800 629 485
China	800 810 0189
Hong Kong	800 938 693
India	1 800 112 929
Japan	0120 (421) 345
Korea	080 769 0800
Malaysia	1 800 888 848
Singapore	1 800 375 8100
Taiwan	0800 047 866
Other AP Countries	(65) 6375 8100

Europe & Middle East

Austria	0800 001122
Belgium	0800 58580
Finland	0800 523252
France	0805 980333
Germany	0800 6270999
Ireland	1800 832700
Israel	1 809 343051
Italy	800 599100
Luxembourg	+32 800 58580
Netherlands	0800 0233200
Russia	8800 5009286
Spain	800 000154
Sweden	0200 882255
Switzerland	0800 805353
	Opt. 1 (DE)
	Opt. 2 (FR)
	Opt. 3 (IT)
United Kingdom	0800 0260637

For other unlisted countries:
www.keysight.com/find/contactus
(BP-09-23-14)

