

ARMY  
NAVY  
AIR FORCE

TM 11-6130-417-14  
EE010-BK-MMA-010/E154 PS30A  
T.O. 35C1-2-848-1

---

TECHNICAL MANUAL

OPERATOR'S,  
ORGANIZATIONAL, DIRECT SUPPORT,  
AND GENERAL SUPPORT MAINTENANCE MANUAL  
FOR  
POWER SUPPLY PP-7833/U  
(NSN-6130-00-249-2748)

---

DEPARTMENTS OF THE ARMY, NAVY. AND AIR FORCE  
25 FEBRUARY 1983



**5**

SAFETY STEPS TO FOLLOW IF SOMEONE IS THE VICTIM OF ELECTRICAL SHOCK

**1**

DO NOT TRY TO PULL OR GRAB THE INDIVIDUAL

**2**

IF POSSIBLE, TURN OFF THE ELECTRICAL POWER

**3**

IF YOU CANNOT TURN OFF THE ELECTRICAL POWER, PULL, PUSH, OR LIFT THE PERSON TO SAFETY USING A WOODEN POLE OR A ROPE OR SOME OTHER INSULATING MATERIAL

**4**

SEND FOR HELP AS SOON AS POSSIBLE

**5**

AFTER THE INJURED PERSON IS FREE OF CONTACT WITH THE SOURCE OF ELECTRICAL SHOCK, MOVE THE PERSON A SHORT DISTANCE AWAY AND IMMEDIATELY START ARTIFICIAL RESUSCITATION

# SUMMARY OF WARNINGS AND CAUTIONS

## WARNING

### DANGEROUS VOLTAGES EXIST IN THIS EQUIPMENT

Be careful when working on the power supplies and their circuits, or on the 230- or 115-volt ac line connections.

DO NOT TAKE CHANCES!

## WARNING

### HIGH TEMPERATURES EXIST IN THIS EQUIPMENT DURING OPERATION.

Do not touch heat sink or other high-temperature components during operation or for a short time after operation.

## CAUTION

When shorting out capacitors, use a load resistor.



TECHNICAL MANUAL  
NO. 11-6130-417-14  
TECHNICAL MANUAL  
EE010-BK-MMA-0101/E154 PS30A  
TECHNICAL ORDER  
T.O. 35C1-2-848-1

TM 11-6130-417-14  
EE010-BK-MMA-010/E154 PS30A  
T.O. 35C1-2-848-1

DEPARTMENTS OF THE ARMY,  
THE NAVY, AND  
THE AIR FORCE

Washington, DC, 25 February 1983

**This manual contains copyright material reproduced by permission of the Hewlett-Packard Company.**

**OPERATOR'S, ORGANIZATIONAL, DIRECT SUPPORT, AND  
GENERAL SUPPORT MAINTENANCE MANUAL  
FOR  
POWER SUPPLY PP-7833/U  
(NSN-6130-00-249-2748)**

**REPORTING ERRORS AND RECOMMENDING IMPROVEMENTS**

You can help improve this manual. If you find any mistakes or if you know of a way to improve the procedures, please let us know. Mail your letter, DA Form 2028 (Recommended Changes to Publications and Blank Forms), or DA Form 2028-2 located in back of this manual direct to: Commander, US Army Communications Electronics Command and Fort Monmouth. ATTN: DRSEL-ME-MP, Fort Monmouth, New Jersey 07703.

For Air Force, submit AFTO Form 22 (Technical Order System Publication Improvement Report and Reply) in accordance with paragraph 6-5, Section VI, T.O. 00-5-1. Forward direct to prime ALC/MST.

For Navy, mail comments to the Commander, Naval Electronics Systems Command, ATTN: ELEX 8122, Washington, DC 20360.

In either case, a reply will be furnished direct to you.

**This manual is an authentication of the manufacturer's commercial literature which, through usage, has been found to cover the data required to operate and maintain this equipment. Since the manual was not prepared in accordance with military specifications and AR301-3, the format has not been structured to consider levels of maintenance.**

## TABLE OF CONTENTS

Section	Page	Section	Page
<b>I</b>			
		<b>GENERAL INFORMATION</b>	
1-A.1	1-1	2-32	AC POWER CABLE STRAIN RELIEF ASSEMBLY . . . . . 2-4
1-A.3	1-1	2-34	INSTALLATION INSTRUCTIONS . . . . . 2-4
1-A.4	1-1	2-36	REPACKING FOR SHIPMENT . . . . . 2-4
1-A.5	1-1		<b>III OPERATING INSTRUCTIONS . . . . . 3-1</b>
1-A.6	1-2	3-1	TURN-ON CHECKOUT PROCEDURE . . . . . 3-1
1-A.8	1-2	3-3	OPERATING MODES . . . . . 3-2
1-A.10	1-2	3-6	NORMAL OPERATING MODE . . . . . 3-2
1-1	1-3	3-8	Constant Voltage Operation . . . . . 3-2
1-8	1-3	3-10	Constant Current Operation . . . . . 3-2
1-10	1-4	3-12	Overvoltage Trip Point Adjustment . . . . . 3-2
1-12	1-4	3-15	Connecting The Load . . . . . 3-3
1-15	1-7	3-20	Operation With No Load . . . . . 3-3
1-17	1-7	3-22	Operation Beyond Rated Output . . . . . 3-3
1-19	1-7	3-24	OPTIONAL OPERATING MODES . . . . . 3-3
<b>II</b>		3-27	Remote Voltage Sensing . . . . . 3-3
		3-34	Remote Programming . . . . . 3-5
<b>INSTALLATION . . . . . 2-1</b>		3-51	Auto-Parallel Operation . . . . . 3-8
2-1	2-1	3-57	Auto-Series Operation . . . . . 3-8
2-3	2-1	3-67	Auto-Tracking Operation . . . . . 3-10
2-5	2-1	3-76	SPECIAL OPERATING CONSIDERATIONS . . . . . 3-12
2-7	2-1	3-77	Pulse Loading . . . . . 3-12
2-9	2-1	3-79	Output Capacitance . . . . . 3-12
2-11	2-1	3-82	Reverse Voltage Protection . . . . . 3-12
2-13	2-1	3-85	Reverse Current Loading . . . . . 3-12
2-15	2-1	3-87	Battery Charging . . . . . 3-12
2-17	2-2	3-91	Battery Discharging . . . . . 3-13
2-20	2-2		<b>IV PRINCIPLES OF OPERATION . . . . . 4-1</b>
2-22	2-2	4-1	OVERALL BLOCK DIAGRAM DISCUSSION . . . . . 4-1
2-24	2-2	4-16	DETAILED CIRCUIT ANALYSIS . . . . . 4-3
2-26	2-3	4-17	Preregulator Control Circuit . . . . . 4-3
2-28	2-3	4-27	Overvoltage Limit Circuit . . . . . 4-4
2-30	2-3	4-29	Series Regulator and Driver . . . . . 4-4
		4-31	Short-Circuit Protection . . . . . 4-4
		4-33	Constant-Voltage Comparator . . . . . 4-4
		4-40	Constant-Current Comparator . . . . . 4-5
		4-45	Voltage Clamp Circuit . . . . . 4-6
		4-48	Mixer and Error Amplifiers . . . . . 4-6
		4-52	Overvoltage Protection Crowbar . . . . . 4-6
		4-58	Turn-On Control Circuit . . . . . 4-7
		4-61	Reference Regulator . . . . . 4-7
		4-66	Meter Circuit . . . . . 4-7
		4-70	Additional Protection Features . . . . . 4-7

TABLE OF CONTENTS (Continued)

Section	Page	Section	Page
<b>V</b>			
<b>MAINTAINANCE</b> . . . . .	5-1		
<b>INTRODUCTION</b> . . . . .	5-1		
<b>TEST EQUIPMENT</b>			
<b>REQUIRED</b> . . . . .	5-2		
5-5 <b>PERFORMANCE TEST</b> . . . . .	5-2	5-112 <b>Complete Removal of A3</b>	
5-7 <b>CONSTANT-VOLTAGE TESTS</b> . . . . .	5-2	<b>Interconnection Board</b> . . . . .	5-21
5-38 <b>CONSTANT-CURRENT TESTS</b> . . . . .	5-6	5-114 <b>Complete Removal of A4</b>	
5-49 <b>TROUBLESHOOTING</b> . . . . .	5-8	<b>Heat Sink</b> . . . . .	5-21
5-54 <b>OVERALL TROUBLE-</b>		5-116 <b>Power Transformer T1</b>	
<b>SHOOTING PROCEDURES</b> . . . . .	5-8	<b>Removal</b> . . . . .	5-21
5-60 <b>Disassembly Procedures</b> . . . . .	5-15	5-118 <b>B2 Fan Removal</b> . . . . .	5-21
5-69 <b>REPAIR AND REPLACEMENT</b> . . . . .	5-16	5-120 <b>Complete Removal of Main Filter</b>	
5-71 <b>ADJUSTMENT AND</b>		<b>Capacitor Bank</b> . . . . .	5-21
<b>CALIBRATION</b> . . . . .	5-16	5-122 <b>B Bus Bars (+B, -B)</b>	
5-73 <b>Meter Zero Adjustment</b> . . . . .	5-16	<b>Removal</b> . . . . .	5-21
5-75 <b>Voltmeter Calibration</b> . . . . .	5-16	5-124 <b>Removal of Standoff Mounts For</b>	
5-77 <b>Ammeter Calibration</b> . . . . .	5-17	<b>A2 RFI Circuit Assembly</b> . . . . .	5-22
5-79 <b>Constant-Voltage Programming</b>		5-126 <b>Removal of Input Power</b>	
<b>Calibration</b> . . . . .	5-17	<b>Terminal Board TB1</b> . . . . .	5-22
5-89 <b>Constant-Current Programming</b>		5-128 <b>Removal of Rear Panel</b> . . . . .	5-22
<b>Calibration</b> . . . . .	5-18	5-130 <b>A5 Front Panel Removal</b> . . . . .	5-22
5-98 <b>Load Transient Recovery Time</b>		5-132 <b>A5 Front Panel Disassembly</b> . . . . .	5-22
<b>Adjustment</b> . . . . .	5-19	5-134 <b>Complete Unit Disassembly</b> . . . . .	5-23
5-100 <b>Ripple Balance Adjustment</b> . . . . .	5-19	5-136 <b>Unit Reassembly</b> . . . . .	5-23
5-102 <b>Preregulator Tracking</b>			
<b>Adjustment</b> . . . . .	5-20	<b>VI</b>	
5-104 <b>Crowbar Trip Voltage</b>		<b>CIRCUIT DIAGRAM AND COMPONENT</b>	
<b>Adjustment</b> . . . . .	5-20	<b>LOCATION DIAGRAMS</b>	
5-106 <b>Maximum Crowbar Trip</b>			
<b>Voltage Adjustment</b> . . . . .	5-20	<b>Appendix</b>	
5-108 <b>Disabling the Crowbar</b> . . . . .	5-20	A	<b>REFERENCES</b> . . . . . A-1
5-110 <b>OVERHAUL AND REBUILD</b> . . . . .	5-21	B	<b>MAINTENANCE ALLOCATION</b> . . . . . B-1
		C	<b>COMPONENTS OF END ITEM AND BASIC</b>
			<b>ISSUE ITEMS LIST</b> . . . . . C-1
		D	<b>ADDITIONAL AUTHORIZATION LIST</b> . . . . . D-1
		E	<b>EXPENDABLE SUPPLIES AND</b>
			<b>MATERIALS LIST</b> . . . . . E-1
			<b>Index</b> . . . . . I-1

## LIST OF ILLUSTRATIONS

1-1	DC Power Supply (0-40V/0-30A) PP-7833/U, Model HP6268B (NSN 6130-00-249-2748).....	1-1	4-1	Overall Block Diagram .....	4-1
2-1	Outline Diagrams .....	2-1	4-2	Operating Focus of a CV/CC Power supply .....	4-2
2-2	Bias Transformer A3T2 Primary Connections for 208Vac Operation and 115Vac Operation .....	2-2	4-3	Triac Phase Control of AC Input Amplitude ..	4-3
2-3	Power Transformer T2 Primary Connections for 208Vac and 115Vac Operation .....	2-3	4-4	Preregulator Control Circuit Waveforms .....	4-4
2-4	Power Transformer T1 Primary Connections for 208Vac Operation .....	2-4	5-1	Constant Voltage Load Regulation Test Setup .....	5-2
2-5	Power Cable .....	2-5	5-2	Ripple Test Setup .....	5-3
2-6	AC Power Cable Strain Relief Assembly ....	2-6	5-3	Noise Spike Measurement Test Setup .....	5-4
3-1	Front Panel Controls and Indicators .....	3-1	5-4	Load Transient Recovery Time Test Setup ..	5-5
3-2	Normal Strapping Panel .....	3-2	5-5	Load Transient Recovery Time Waveforms ..	5-6
3-3	Remote Sensing .....	3-4	5-6	Current Sampling Resistor Connections .....	5-7
3-4	Resistance Programming of Output Voltage .....	3-5	5-7	Constant-Current Load Regulation Test Setup .....	5-8
3-5	Voltage Programming of Output Voltage (Unit Gain) .....	3-6	5-8	Constant-Current Ripple and Noise Test Setup .....	5-8
3-6	Voltage Programming of Output Voltage (Variable Gain) .....	3-6	5-9	Zero Adjust Section of Main Circuit Board ..	5-17
3-7	Resistance Programming of Output Current .....	3-7	6-1	A2 RFI Assembly Component Locations .....	6-1
3-8	Voltage Programming of Output Current (Fixed Gain) .....	3-7	6-2	A3 Interconnection Board Component Location .....	6-1
3-9	Voltage Programming of Output Current (Variable Gain) .....	3-6	6-3	Chassis Component Locations, Top View ..	6-2
3-10	Auto-Parallel Operation of Two Units .....	3-8	6-4	Chassis Component Locations, Bottom View .....	6-2
3-11	Auto-Parallel Operation of Three Units .....	3-9	6-5	A4 Heat Sink Assembly, Top and Front View .....	6-3
3-12	Auto-Series Operation of Two Units .....	3-10	6-6	A4 Heat Sink Assembly, Bottom and Rear View .....	6-3
3-13	Auto-Series Operation of Three Units .....	3-10	6-7	A1 Board Component Locations .....	6-4
3-14	Auto Tracking Operation of Two Units .....	3-11	6-6	Rear Panel .....	6-5
3-15	Auto Tracking Operation of Three Units .....	3-12	6-9	Rear Side of Front Panel .....	6-5
3-16	Battery Charging .....	3-13	FO-1	Models 6259B, 6260B, 6261B, 6268B, and 6269B Schematic Diagram .....	-
3-17	Battery Discharging .....	3-14	FO-2	A4 Heat Sink Assembly Emitter Resistor Board Component Locations .....	-
			FO-3	Interconnection Diagram .....	-

(Sheets 1 thru 3)



**SECTION 1  
GENERAL INFORMATION**

**1-A.1 SCOPE**

1-A.2 This manual describes the organizational, direct support (DS) and general support (GS) maintenance of the DC Power Supply (0-40VDC/0-30A) PP-7833/U, Model HP6268B (fig. 1-1) hereafter referred to as the DC power supply or instrument. This manual contains instructions for operating and maintaining the five models of the power supply. If a procedure for one or more models differs from the general procedure, alternate steps are included to accommodate the differing units. Although the Model 6268B is emphasized, it is incumbent on the reader to select only those procedures related to the particular model with which he is concerned. A complete listing of reference publications is provided in Appendix A. The Maintenance Allocation Chart is in Appendix B. The Repair Parts and Special Tools List (RPSTL) is contained in TM 11-6130-417-24P.

**1-A.3 INDEX OF TECHNICAL PUBLICATIONS**

- a. Army. Refer to the latest issue of DA Pam 310-1 to determine whether there are new editions, changes or additional publications pertaining to the equipment.
- b. Air Force Use T.O. 0-1-31 Series Numerical Index and Requirements Table (NIRT).

**1-A.4 MAINTENANCE FORMS, RECORDS AND REPORTS**

a. Reports of Maintenance and Unsatisfactory Equipment. Department of the Army forms and procedures used for equipment maintenance will be those prescribed by TM 38-750, the Army Maintenance Management System (Army). Air Force personnel will use AFR 66-1 for maintenance reporting and TO-00-35D54 for unsatisfactory equipment reporting. Navy personnel will report maintenance performed utilizing the Maintenance Data Collection Subsystem (MDCS) IAW OPNAVINST 4790.2, Vol 3, and unsatisfactory material/conditions (UR submissions) IAW OPNAVINST 4790.2, Vol 2, chapter 17.

b. Report of Packaging and Handling Deficiencies. Fill out and forward SF 364 (Report of Discrepancy (ROD)) as prescribed in AR 735-11-2/DLAR 4140.55/NAVMATINST 4355.73/AFR 400-54/MCO 4430. 3E.

c. Discrepancy in Shipment Report (DISREP) (SF 316). Fill out and forward Discrepancy in Shipment Report (DISREP) (SF 361) as prescribed in AR 55-38/NAVSUPINST 4610.33B/AFR 75-18/MCO P4610.19C/DLAR 4500.15.

**1-A.5 REPORTING EQUIPMENT IMPROVEMENT RECOMMENDATIONS (EIR)**

a. Army. If your DC Power Supply (0-40 VDC/0-30A) Model HP6268B needs improvement, let us know. Send us an

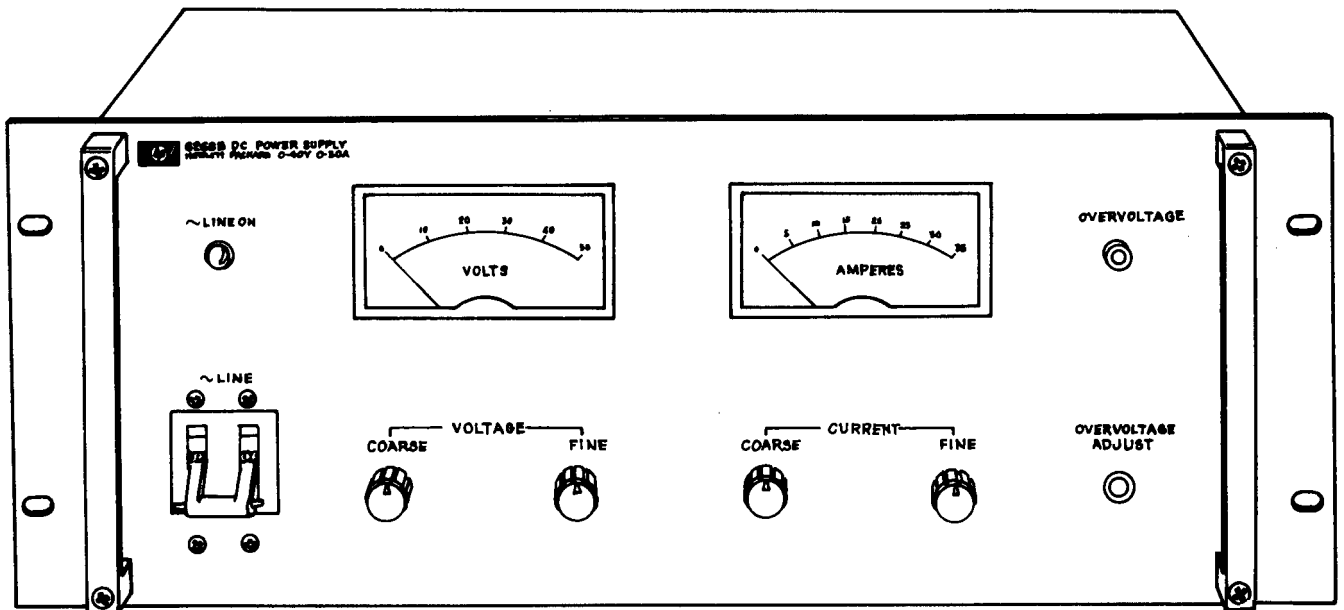

Figure 1-1. DC Power Supply (0-40 VDC/0-30A) PP-7833/U, Model HP6268B

8731-82

EIR. You, the user, are the only one who can tell us what you don't like about your equipment. Let us know why you don't like the design. Put it on an SF 368 (Quality Deficiency Report). Mail it to Commander, US Army Communications-Electronics Command and Fort Monmouth, ATTN: DRSEL-ME-MP, Fort Monmouth, New Jersey 07703. We'll send you a reply.

b. Air Force. Air Force personnel are encouraged to submit EIR's in accordance with AFM 900-4.

c. Navy. Navy personnel are encouraged to submit EIR's through their local Beneficial Suggestion Program.

### **1-A.6 ADMINISTRATIVE STORAGE**

1-A.7 Administrative Storage of equipment issued to and used by Army activities will have preventive maintenance performed in accordance with the PMCS procedures before storing. When removing the equipment from administrative storage, an operational check should be performed as per paragraph 3-2 to assure opera-

tional readiness. Disassembly and repacking of equipment for shipment or limited storage are covered in TM-749-90-1.

### **1-A.8 DESTRUCTION OF ARMY ELECTRONICS MATERIEL**

**1-A.9** Destruction of Army electronics materiel to prevent enemy use shall be in accordance with TM 750-244-2.

### **1-A.10 PURPOSE AND USE**

1-A11 The supply is used as a power source to provide regulated zero to 40 Vdc for test procedures for the Central Message Switch and Automatic AN/TYC-39(V)1 and Circuit Switch AN/TTC-39(V)1, V2 and V3. The output of the supply can be varied from zero to fully rated voltage or current via manual controls or by remote programming.

## 1-1 DESCRIPTION

1-2 The five constant-voltage/constant current power supply models included in this manual use a transistor series-regulator combined with a triac preregulator for high efficiency, excellent regulation, and low ripple and noise. These supplies are packaged in 7-inch high full-rack-width cabinets that are suitable for either bench or relay rack operation.

1-3 The outputs of these supplies can be varied from zero to full rated voltage or current by setting coarse and fine voltage and current controls on the front panel or they can be programmed remotely by resistance or voltage inputs to rear panel terminals. When the voltage controls are used to establish a constant output voltage, the current controls establish a current limit that can protect the load from over-current. When the current controls are used to establish a constant output current, the voltage controls establish a voltage limit that can protect the load from excessive voltage. The crossover from constant-voltage to constant-current operation, or vice versa, occurs automatically when the load current reaches the value established by the current controls or the voltage reaches the value established by the voltage controls. The output voltage and current can both be monitored continuously on front panel meters.

1-4 Output loads are further protected by a built-in fast-acting overvoltage protection crowbar circuit that automatically shorts the supply's output terminals if a preset voltage limit is exceeded. A front panel control sets the voltage at which the crowbar trips and can be adjusted from approximately 10% to 110% of the supply's maximum rated voltage. When several supplies are installed in the same system, whether in series, parallel, or independently, their crowbar circuits can be interconnected so that all will trip simultaneously whenever any one of them does.

1-5 These power supplies are forced air cooled.

1-6 The ac input connections to these supplies are made at rear panel terminals. All dc output, remote sensing, and remote programming connections are also made at rear panel terminals. Either the positive or negative output terminal of a supply may be grounded or the supply's output may be floated at up to 300 volts above ground.

1-7 Remote programming, remote sensing, and several

methods of operating supplies in combination of two or three are made possible by rear panel terminals that allow access to control points within the regulator circuits. These capabilities are described below.

a. Remote Programming. The power supply's output voltage or current (or both) can be controlled from a remote location by varying a resistance or a voltage input signal to the supply's voltage or current regulator circuit.

b. Remote Sensing. Connecting the voltage regulator's feedback circuit to the load terminals rather than to the supply's output terminals prevents the voltage drop in the load leads from impairing voltage regulation at the load when operating in the constant voltage mode. A separate pair of sensing leads which carry no load current extend the feedback loop to the load terminals.

c. Auto-Parallel Operation. Two or three similar supplies connected in parallel can be made to share loads equally and can be controlled by the voltage and current controls (or remote programming terminals) of one of the supplies designated the master if they are connected for auto-parallel operation. Normally, only supplies having the same model number are connected in auto-parallel, but auto-parallel operation can be used with any of the supplies covered by this manual that have equal current capabilities.

d. Auto-Series Operation. Two or three supplies can be connected in series and have their outputs simultaneously controlled by the voltage and current controls (or remote programming terminals) of one of the supplies designated the master. The voltage contributed by each slave is maintained in a constant ratio to that of the master. These ratios can be set as desired. Auto-series operation provides higher output voltages in constant voltage operation and greater voltage compliance in constant current operation. Any HP supply that offers auto-series operation can serve as a slave supply; the master supply does not have to be an auto-series model.

e. Auto-Tracking Operation. Auto-tracking is similar to auto-series operation except that two or three supplies share a common negative output bus and are interconnected so that the output voltage of each slave supply is maintained at some constant fraction of that of the master supply. All of the supplies are controlled through the master supply, and each supply feeds a separate load.

## 1-8 SPECIFICATIONS

1-9 Detailed specifications for these power supplies are given in Table 1-1.

## 1-10 OPTIONS

1-11 Options are customer-requested factory modifications of a standard instrument. The following options are available for the instruments covered by this manual. Where necessary, detailed coverage of the options is included throughout the manual.

<u>Option No.</u>	<u>Description</u>	<u>Option No.</u>	<u>Description</u>
005	<u>Realignment for 50Hz Operation:</u> Standard instruments are designed for 57 to 63Hz operation. For 50Hz operation, a resistor in the preregulator control circuit is changed and the preregulator is realigned.	020	<u>Adjustable Voltage Programming:</u> Two screwdriver-adjustable controls accessible through holes in the rear panel allow the voltage programming coefficient and zero output voltage to be adjusted conveniently to an accuracy of 0.1%.
007	<u>Ten-Turn Output Voltage Control:</u> A ten-turn control replaces the coarse voltage control for improved resolution in setting the output voltage.	021	<u>Adjustable Current Programming:</u> Two screwdriver-adjustable controls accessible through holes in the rear panel allow the current programming coefficient and zero output current to be adjusted conveniently to an accuracy of 0.1%.
008	<u>Ten-Turn Output Current Control:</u> A ten-turn control replaces the coarse current control for improved resolution in setting the output current.	022	<u>Adjustable Voltage and Current Programming:</u> This option includes Options 020 and 021 in the same instrument.
009	<u>Ten-Turn Output Voltage and Current Controls:</u> This option includes Options 007 and 008 in the same instrument.	026	<u>Rewiring for 115Vac <math>\pm</math>10% Single-Phase Input (Models 6259B, 6261B, and 6268B only):</u> This factory modification replaces the circuit breaker (except in the Model 6259B), adds a resistor to the A2 assembly, and reconnects the power transformer, bias transformer, preregulator choke, and fans for 115Vac operation.
010	<u>Chassis Slides:</u> Factory installed slides permit convenient access to the interior of a rack mounted supply for maintenance.	027	<u>Rewiring for 208Vac <math>\pm</math>10% Single-Phase Input:</u> This factory modification reconnects the power and bias transformers for 208Vac operation.
013	<u>Three-Digit Graduated Decadal Voltage Control:</u> To improve mechanical stability and permit accurate resetting of the output voltage, Option 013 replaces the coarse voltage control with a ten-turn control equipped with a 3-digit turns-counting dial.	040	<u>Interfacing for Multiprogrammer Operation:</u> This factory modification prepares standard power supplies for resistance programming by the 6940B Multiprogrammer or the 6941B Multiprogrammer Extender. Operation with either of these instruments requires that the power supply be subjected to a special calibration and a protection checkout. The special calibration insures that the power supply can be accurately set to zero and to the maximum rated output voltage or current when programmed by the multiprogrammer. The protection checkout insures that the power supply will not be damaged by the rapid repetitive programming possible with the multiprogrammer. This option includes Option 022.
014	<u>Three-Digit Graduated Decadal Current Control:</u> To improve mechanical stability and permit accurate resetting of the output current, Option 014 replaces the coarse current control with a ten-turn control equipped with a 3-digit turns-counting dial.		
016	<u>Rewiring for 115Vac <math>\pm</math>10% Single-Phase Input (Model 6260B only):</u> This factory modification replaces the circuit breaker and power transformer, adds a resistor to the A2 assembly, and reconnects the bias transformer, preregulator choke, and fans for 115Vac operation.		

## 1-12 INSTRUMENT/MANUAL IDENTIFICATION

1-13 Hewlett-Packard power supplies are identified by a

two-part serial number. The first part is the serial number prefix, a number-letter combination that denotes the date of a significant design change and the country of manufacture. The first two digits indicate the year (10 = 1970, 11 = 1971, etc.), the second two digits indicate the week, and the letter "A" designates the U. S. A. as the country of manufacture. The second part is the power supply serial number. A different sequential number is assigned to each power supply, starting with 00101.

**1-14** If the serial number on your instrument does not agree with those below, Change Sheets supplied with the manual define

the differences between your instrument and the instrument described by this manual.

**\*Operating and Service Manual for**  
**Model 6259B, Serials 1535A - 00661 and above**  
**Model 6260B, Serials 1545A - 01026 and above**  
**Model 6261B, Serials 1543A - 00551 and above**  
**Model 6268B, Serials 1539A- 01481 and above**  
**Model 6269B, Serials 1535A- 01631 and above**

● For instruments with serial numbers above those listed, a change page may be included.

Table 1-1 Specifications: Models 6259B, 6260B, 6261B, 6268B, 6269B

<p><b>INPUT:</b>                  230Vac <math>\pm 10\%</math>, single phase, 57-63Hz for the standard models. (For other input voltages or 50Hz operation, see the option listings in paragraph 1-10. Input power requirements are listed in paragraph 2-15.</p> <p><b>OUTPUT:</b></p> <table border="0"> <tr> <td>Model</td> <td>6259B</td> <td>0-10 volts at 0-50 amps</td> </tr> <tr> <td></td> <td>6260B</td> <td>0-10 volts at 0-100 amps</td> </tr> <tr> <td></td> <td>6261B</td> <td>0-20 volts at 0-50 amps</td> </tr> <tr> <td></td> <td>6268B</td> <td>0-40 volts at 0-30 amps</td> </tr> <tr> <td></td> <td>6269B</td> <td>0-40 volts at 0-50 amps</td> </tr> </table> <p><b>LOAD EFFECT (LOAD REGULATION):</b>  <u>Constant Voltage</u> – Less than 0.01% of output plus 200<math>\mu</math>V for a load change equal to the current rating of the supply.  <u>Constant Current</u> –                  Models 6259B and 6261B – Less than 0.02% of output plus 1mA for a load change equal to the voltage rating of the supply.                  Models 6260B, 6268B, and 6269B – Less than 0.02% of output plus 2mA for a load change equal to the voltage rating of the supply.</p> <p><b>SOURCE EFFECT (LINE REGULATION):</b>  <u>Constant Voltage</u> – Less than 0.01% of output plus 200<math>\mu</math>V for a change in line voltage between 208 and 254Vac (or 104 and 127Vac) at any output voltage and current within rating.  <u>Constant Current</u> –                  Models 6259B and 6261B – Less than 0.02% of output plus 1mA for a change in line voltage between 208 and 254Vac (or 104 and 127Vac) at any output voltage and current within rating.                  Models 6260B, 6268B, and 6269B – Less than 0.02% of output plus 2mA for a change in line voltage between 208 and 254Vac (or 104 and 127Vac) at any output voltage and current within rating.</p>	Model	6259B	0-10 volts at 0-50 amps		6260B	0-10 volts at 0-100 amps		6261B	0-20 volts at 0-50 amps		6268B	0-40 volts at 0-30 amps		6269B	0-40 volts at 0-50 amps	<p><b>PARD (RIPPLE AND NOISE):</b>                  (Measured within 20Hz to 20MHz bandwidth)</p> <table border="0"> <thead> <tr> <th>Model</th> <th>Constant Voltage</th> <th>Constant Current</th> </tr> </thead> <tbody> <tr> <td>6259B</td> <td>500<math>\mu</math>Vrms/5mV p-p</td> <td>25mA rms</td> </tr> <tr> <td>6260B</td> <td>500<math>\mu</math>Vrms/5mV p-p</td> <td>50mA rms</td> </tr> <tr> <td>6261B</td> <td>500<math>\mu</math>Vrms/5mV p-p</td> <td>25mA rms</td> </tr> <tr> <td>6268B</td> <td>1mVrms/5mV p-p</td> <td>20mA rms</td> </tr> <tr> <td>6269B</td> <td>1mVrms/5mV p-p</td> <td>25mA rms</td> </tr> </tbody> </table> <p><b>TEMPERATURE COEFFICIENT:</b>  <u>Constant Voltage</u> – Less than 0.01% plus 200<math>\mu</math>V change in output per degree Celsius change in ambient following a 30-minute warmup.  <u>Constant Current</u> –                  Models 6259B, 6261B, and 6269B – Less than 0.01% plus 4mA change in output per degree Celsius change in ambient following a 30-minute warmup.                  Model 6260B – Less than 0.01% plus 8mA change in output per degree Celsius change in ambient following a 30-minute warmup.                  Model 6268B – Less than 0.01% plus 2mA change in output per degree Celsius change in ambient following a 30-minute warmup.</p> <p><b>DRIFT (STABILITY):</b>                  (Change in output (dc to 20Hz) over an 8-hour interval under constant line, load, and ambient temperature following a 30-minute warmup.)  <u>Constant Voltage</u> – Less than 0.03% of output plus 2mV.  <u>Constant Current</u> –                  Models 6259B, 6261B, and 6269B – Less than 0.03% of output plus 10mA.                  Model 6260B – Less than 0.03% of output plus 20mA.                  Model 6268B – Less than 0.03% of output plus 5mA.</p>	Model	Constant Voltage	Constant Current	6259B	500 $\mu$ Vrms/5mV p-p	25mA rms	6260B	500 $\mu$ Vrms/5mV p-p	50mA rms	6261B	500 $\mu$ Vrms/5mV p-p	25mA rms	6268B	1mVrms/5mV p-p	20mA rms	6269B	1mVrms/5mV p-p	25mA rms
Model	6259B	0-10 volts at 0-50 amps																																
	6260B	0-10 volts at 0-100 amps																																
	6261B	0-20 volts at 0-50 amps																																
	6268B	0-40 volts at 0-30 amps																																
	6269B	0-40 volts at 0-50 amps																																
Model	Constant Voltage	Constant Current																																
6259B	500 $\mu$ Vrms/5mV p-p	25mA rms																																
6260B	500 $\mu$ Vrms/5mV p-p	50mA rms																																
6261B	500 $\mu$ Vrms/5mV p-p	25mA rms																																
6268B	1mVrms/5mV p-p	20mA rms																																
6269B	1mVrms/5mV p-p	25mA rms																																

Table 1-1 Specifications: Models 6259B, 6260B, 6261B, 6268B, 6269B (Continued)

**LOAD TRANSIENT RECOVERY TIME:**

Less than 50μsec is required for output voltage recovery (in constant voltage operation) to within 10mV of the nominal output following a change in output current equal to the current rating of the supply or 5 amps, whichever is smaller.

**REMOTE PROGRAMMING COEFFICIENTS:**

Output Voltage Programming –

Model	Resistance Control (±1%)	Voltage Control (±1%)
All Models	200Ω/V	1V/V

Output Current Programming –

Model	Resistance Control (±10%)	Voltage Control (±10%)
6259B	4Ω/A	10mV/A
6260B	2Ω/A	5mV/A
6261B	4Ω/A	10mV/A
6268B	6Ω/A	16.7mV/A
6269B	4Ω/A	10mV/A

**REMOTE PROGRAMMING SPEED:**

(Typical time required to nonrepetitively change from zero to within 99.9% of the maximum rated output voltage, or from the maximum rated output voltage to within 0.1% of that voltage above zero.)

Model	Up, Full Load	Down, Full Load
6259B	70ms	10ms
6260B	70ms	5ms
6261B	150ms	25ms
6268B	300ms	30ms
6269B	350ms	20ms

Model	Up, No Load	Down, No Load
6259B	70ms	200ms
6260B	70ms	200ms
6261B	150ms	250ms
6268B	300ms	1sec
6269B	350ms	1sec

**PANEL METERS:**

The accuracy of the front panel voltmeter and ammeter is ±2% of full scale. The ranges of these meters are:

Model	Model
6259B 12V, 60A	6268B 50V, 35A
6260B 12V, 120A	6269B 50V, 60A
6261B 24V, 60A	

**TEMPERATURE RATINGS:**

Operating 0 to 55°C Storage -40 to +75°C

**COOLING:**

These power supplies are forced air cooled. The Model 6259B is cooled by a single fan; the other models are cooled by two fans.

**RESOLUTION:**

(Minimum output voltage or current change that can be obtained using the front panel controls.)

Model	Constant Voltage	Constant Current
6259B	1mV	50mA
6260B	1mV	100mA
6261B	2mV	50mA
6268B	5mV	30mA
6269B	5mV	50mA

**OUTPUT IMPEDANCE (TYPICAL):**

Approximated by a resistance in series with an inductance as follows:

Model	Model
6259B 0.05mΩ, 1μH	6268B 0.2mΩ, 1μH
6260B 0.02mΩ, 1μH	6269B 0.1mΩ, 1μH
6261B 0.01mΩ, 1μH	

**OVERVOLTAGE PROTECTION CROWBAR:**

To avoid false tripping, the recommended trip margin above the output voltage is 5% of the output voltage plus 2 volts for Models 6259B, 6260B, and 6261B, and 5% of the output voltage plus 1 volt for Models 6268B and 6269B. The approximate crowbar trip voltage ranges are:

Model	Model
6259B 2V-12V	6268B 4V-45V
6260B 2V-12V	6269B 4V-45V
6261B 2V-23V	

**OPTIONS AVAILABLE:**

(See paragraph 1-10 for descriptions)

All Models – Options 005, 007, 008, 009, 010, 013, 014, 020, 021, 022, 027, 040.

Model 6260B only – Option 016.

Model 6259B, 6261B, and 6268B only – Option 026.

**INPUT POWER CONNECTIONS:**

Input power is connected by way of a 3-terminal barrier strip on the rear panel.

**DIMENSIONS:**

(See Figure 2-1 outline diagrams.)

**WEIGHT:**

Model	Net	Shipping
6259B	69 lbs. (31.3 kg)	78 lbs. (35.3 kg)
6260B	97 lbs. (43.9 kg)	106 lbs. (48.0 kg)
6261B	78 lbs. (35.3 kg)	87 lbs. (39.4 kg)
6268B	76 lbs. (34.4 kg)	84 lbs. (38.1 kg)
6269B	89 lbs. (40.3 kg)	98 lbs. (44.0 kg)

### **1-15 ORDERING ADDITIONAL MANUALS**

1-16 One manual is shipped with each power supply. Additional manuals may be obtained from regular publication distribution channels.

### **1-17 EQUIPMENT SUPPLIED**

1-18 The equipment supplied with each Model HP6266B Regulated DC Power Supply (0-40 VDC/0-30A) is an AC cable strain relief assembly HP Part No. 5060-2744. This item is used to reduce the possible hazard of an accidental disconnecting of the user-supplied ac power cable. The enclosed strain relief assembly

with related hardware must be installed when the power supply is installed.

### **1-19 ACCESSORY EQUIPMENT AVAILABLE**

1-20 The standard model of the 0-40 Vdc Power Supply is ordinarily wired for 230 Vac input power. However, with respect to the HP6268B model (to which this manual is chiefly dedicated), the standard model has already been adapted to 115 Vac input power by: replacing the circuit breaker, by adding a resistor, and by rearranging certain jumpers. In summary, two pieces of accessory equipment have already been added to the standard model to establish this HP6268B model with the 026 option.





## SECTION II INSTALLATION

### 2-1 INITIAL INSPECTION

2-2 Before shipment, this instrument was inspected and found to be free of mechanical and electrical defects. As soon as the instrument is unpacked, inspect for any damage that may have occurred in transit. Save all packing materials until the inspection is completed. If damage is found, take action immediately.

### 2-3 Mechanical Check

2-4 This check should confirm that there are no broken knobs or connectors, that the cabinet and panel surfaces are free of dents and scratches, and that the meters are not scratched or cracked.

### 2-5 Electrical Check

2-6 The instrument should be checked against its electrical specifications. Section V includes an "in-cabinet" performance check to verify proper instrument operation.

### 2-7 INSTALLATION DATA

2-8 The instrument is shipped ready for permanent rack installation or bench operation. It is necessary only to connect a user-supplied power cord to the power supply, install the AC power cable strain relief assembly and connect power cord to source of supply. See paragraph 2-34 for procedures.

### 2-9 Location and Cooling

2-10 These instruments are fan-cooled and must be installed with sufficient space for cooling air to reach their sides. These power supplies should be used in an area where the ambient temperature does not exceed 55°C.

### 2-11 Outline Diagram

2-12 Figure 2-1 shows the outline shape and dimensions of these supplies.

### 2-13 Rack Mounting

2-14 This instrument is full rack size and can be easily rack mounted in a conventional 19-inch rack panel using standard mounting screws.

### 2-15 INPUT POWER REQUIREMENTS

2-16 The standard instrument is wired for a nominal input of 230Vac 57-63Hz when it is shipped from the factory. The supplies covered by this manual are also available equipped for a 208-volt input (Option 027), and except for the Model 6269B, are also available equipped for a 115-volt input (Option 026 for Models 6259B, 6261B, and 6268B, or Option 016 for the Model 6260B). In addition, all five models are available in a 50Hz version. The input voltage and frequency required is marked on the rear panel of the

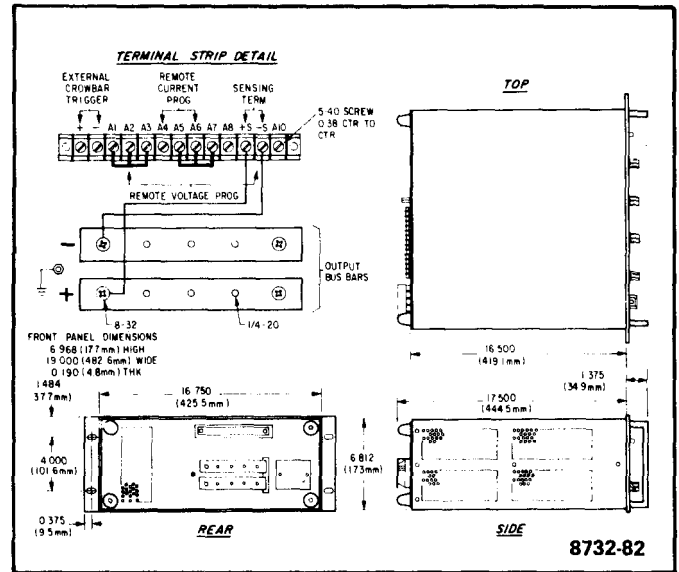

**Figure 2-1. Outline Diagrams  
(Models 6259B, 6260B, 6261B, 6268B, and 6269B)**

supply. Except for the Model 6269B, which cannot be converted to 115-volt operation, a standard instrument can be converted by the user to 208 or 115-volt and to 50Hz operation by following the instructions given in the following paragraphs. The standard instrument requires the input current and power listed below when operated at full load from a 230-volt source. When the supply is operated from a 115-volt source, the input current is approximately twice the amount listed.

Model	Input Current	Input Power
6259B	6A	850W
6260B	12A	1600W
6261B	12A	1500W
6268B	12A	1600W
6269B	18A	2500W

In view of the fact that the HP6268B model uses 24 amperes during 115-Vac operation, the 20-ampere circuit breaker CB1 must be replaced with a circuit breaker that will handle a greater current value. Option 026 specifies that, for 115-Vac operation, circuit breaker CB1 have the following rating: 30A, 250 Vac, 2-pole. In addition, a resistor A2R3 is added to the A2 RFI assembly. Some jumpers are rerouted on the A2 RFI assembly, on the A3T2 bias transformer, and on the T1 power transformer. See paragraph 2-25 for details. The rear panel of the power supply at hand should be examined to ensure that the unit is wired correctly for the intended power source.

## 2-17 INPUT LINE VOLTAGE OR FREQUENCY CONVERSION

2-18 Converting a 230-volt instrument to 208-volt operation is simply a matter of changing some taps or jumper connections on main power transformer T1 and bias transformer A3T2. Converting to 115-volt operation is more involved. The Models 6259B, 6260B, 6261B, and 6268B require an added resistor and some jumper changes in the A2 RFI assembly and changed A3T2 and T1 transformer taps. In addition, the 6260B, 6261B, and 6268B need a replacement circuit breaker, and the 62606 needs a replacement T1 power transformer. Complete line voltage conversion instructions are given in paragraphs 2-20 through 2-27.

2-19 Converting a 60Hz instrument to 50Hz operation requires that one resistor be replaced and some adjustments be made. Line frequency conversion instructions are given in paragraph 2-28.

### 2-20 Converting a Standard Instrument to 208-Volt Operation (Models 6259B, 6261B and 6268B).

2-21 To convert these 230-volt instruments to 208-volt operation, proceed as follows:

- a. Disconnect instrument from power source and remove top and bottom covers.
- b. Remove A2 RFI assembly as described in steps (a) through (c) of paragraph 5-65. This provides access to bias transformer A3T2 (see Fig. 6-2).
- c. Locate the wire that connects circuit breaker CBI to the A3T2 bias transformer terminal marked "230 V", disconnect it from the transformer, and reconnect it to the terminal marked "208V". Leave the wire from fan B2 (not used in the 6259B) connected to the terminal marked "230V" (see Fig. 2-2B).
- d. Re-install the RFI assembly by reversing the procedure of step (b) above.
- e. Unsolder the wire connected to terminal 5 of power transformer T1 and solder it instead to terminal 4 (see Figure 2-3 B).

### 2-22 Converting a Standard Instrument to 208-Volt Operation (Models 62606 and 6269B).

2-23 To convert these 230-volt instruments to 208-volt operation, proceed as follows:

- a. Perform steps (a) through (d) of paragraph 2-21.
- b. Unsolder the wire connected to the terminal marked "230V" on power transformer T1 and solder it instead to the terminal marked "208V" (see Fig. 2-4B).

### 2-24 Converting a Standard Instrument to 115-Volt Operation (Models 6259B, 6261B and 6268B).

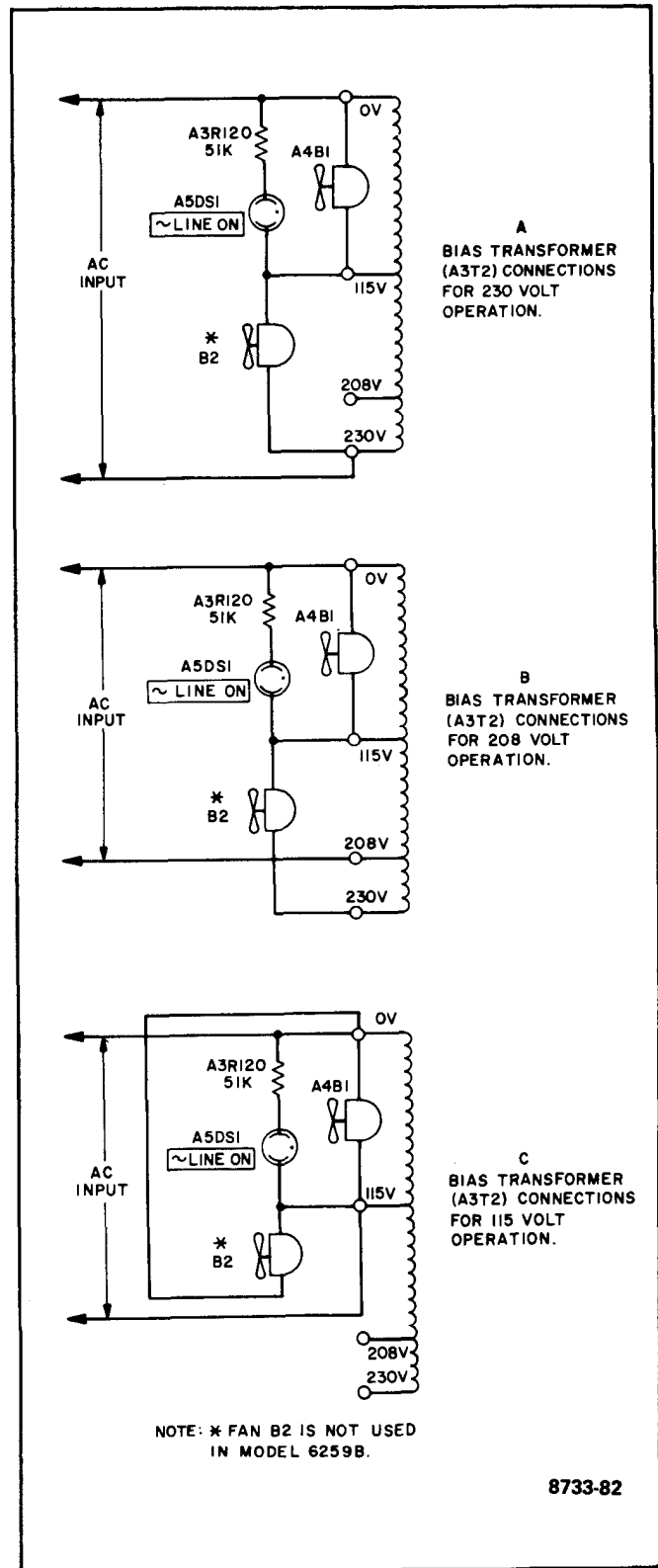

Figure 2-2. Bias Transformer A3T2 Primary Connections for 208 Vac Operation (Model 6259B, 6260B, 6261B, 6266B, and 6269B) and 115 Vac Operation (except Model 6269B).

2-25 To convert these 230-volt instruments to 115-volt operation, proceed as follows:

- a. (Omit this step for the Model 6259B.) Obtain and install a new circuit breaker CB1. Refer to Option 026 in the RPSTL parts list for its current rating and HP Part Number. Connections to the replacement are the same as those to the original breaker.
- b. Remove and partially disassemble the A2 RF I assembly as described in steps (a) through (d) of paragraph 5-65.
- c. Unsolder jumper J3 from the A2 circuit board (see Fig. 6-1) and install jumpers J1 and J2. Also install resistor A2R3 on the circuit board. Refer to Option 026 in the RPSTL parts list for its description and HP Part Number. Replace cover on RFI assembly.
- d. Locate the wire that connects circuit breaker CBI to the A3T2 bias transformer terminal marked "230V", disconnect it from the transformer, and reconnect it to the terminal marked "115V." Also disconnect the wire from fan B2 (not used in the 6259B) from the terminal marked "230V" and reconnect it to the terminal marked "0V" (see Fig. 2-2C).
- e. Re-install the RFI assembly by reversing the procedure of step (b).
- f. Unsolder the jumper connecting terminals 2 and 3 of power transformer T1 (see Fig. 2-3C) and solder jumpers between terminals 1 and 3, and 2 and 5.

### 2-26 Converting a Standard Instrument to 115-Volt Operation (Model 62606)

2-27 To convert the standard Model 6260B to 115-volt operation, proceed as follows:

- a. Obtain and install a new power transformer (T1) and a new circuit breaker (CB1). Refer to Option 016 in the RPSTL parts list for their description and HP Part Number. The new transformer has two primary terminals. Transfer the wire from the "0V" terminal on the old transformer to the "0V" on the new one, and from the "230V" terminal on the old one to the "115V" terminal on the new one. The connections to the replacement circuit breaker are the same as to the old one.
- b. Perform steps (b) through (e) of paragraph 2-25.

### 2-28 Converting a Standard Instrument to 50Hz Operation

2-29 To convert a 60Hz instrument to 50Hz operation, proceed as follows:

- a. Replace A1 R82 with a 240 ohm 5% 1/2-watt resistor. Refer to the RPSTL parts list under Option 005 for the HP Part Number of a suitable replacement.
- b. After replacing A2I R82, perform the preregulator tracking adjustment given in paragraph 5-102.
- c. Check the ripple balance adjustment by the procedure given in paragraph 5-100.

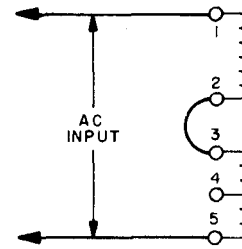

A  
INPUT POWER  
TRANSFORMER (T1) PRIMARY  
CONNECTIONS FOR  
230 VOLT OPERATION

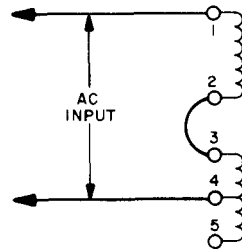

B  
INPUT POWER  
TRANSFORMER (T1) PRIMARY  
CONNECTIONS FOR  
208 VOLT OPERATION.

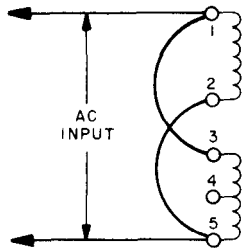

C  
INPUT POWER  
TRANSFORMER (T1) PRIMARY  
CONNECTIONS FOR  
115 VOLT OPERATION.

8734-82

Figure 2-3. Power Transformer T1 Primary Connections for 208 Vac and 115 Vac Operation (Model 6259B, 6261B, and 6268B)

### 2-30 INPUT POWER CONNECTIONS

2-31 No input power cable is supplied with the instruments covered by this manual. Input power connections are made to a 3-terminal barrier block on the rear panel. Its center terminal is grounded to the instrument chassis. To protect operating personnel, the National Electrical Manufacturers Association (NEMA) recommends that the instrument panel and cabinet be grounded. The user-supplied power cable should have three conductors (with the third conductor grounded) and should be of adequate wire size to handle the input current drawn by the supply (see paragraph 2-15). Note that when the supply is operated from a 115-volt source, the input current is approximately twice that shown in paragraph 2-15.

## 2-32 AC POWER CABLE STRAIN RELIEF ASSEMBLY

2-33 To reduce the possible hazard of an accidental disconnecting of the AC power cable, the following named assembly must be attached to the 3-terminal barrier block CB1 when the power supply is installed: AC Power Cable Strain Relief Assembly HP Part No. 5060-2744, Figure 2-6 shows an exploded view for the assembly.

## 2-34 INSTALLATION INSTRUCTIONS

(Figures 2-5 and 2-6)

2-35 To install the strain relief assembly, proceed as follows:

- a. Fabricate power cable as per Figure 2-5.
- b. Remove two screws (1) that secure the transparent barrier strip (2) to the 3-terminal barrier block CB1.
- c. Route power-cord lugs up to lower connection screws and connect them.
- d. Clamp the cable support (3) and cable bracket (4) to the cable as shown.
- e. Mount transparent cover (2) and cable support (3) and strain relief bracket (4) over the barrier block CB1 using the screws removed in step b. For adequate insulation, do not omit transparent barrier block transparent cover.

### NOTE

*Once installed, the power supply must not be set to rest on its rear panel.*

## 2-36 REPACKAGING FOR SHIPMENT

2-37 To insure safe shipment of the instrument, it is recommended that the package designed for the instrument be used. The original packaging material is reusable. If it is not available, refer to MIL-C-1046.

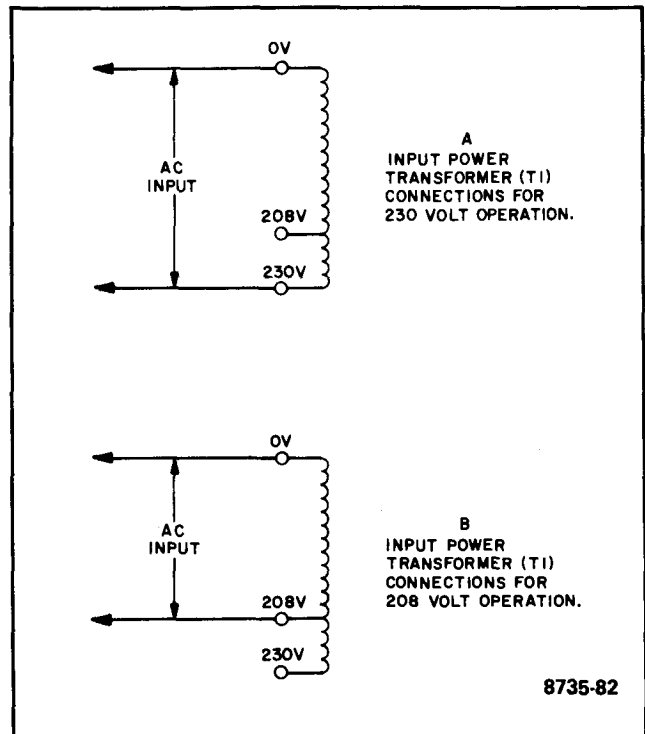

Figure 2-4. Power Transformer T1 Primary Connections for 208Vac Operation (Model 6260B and 6269B)

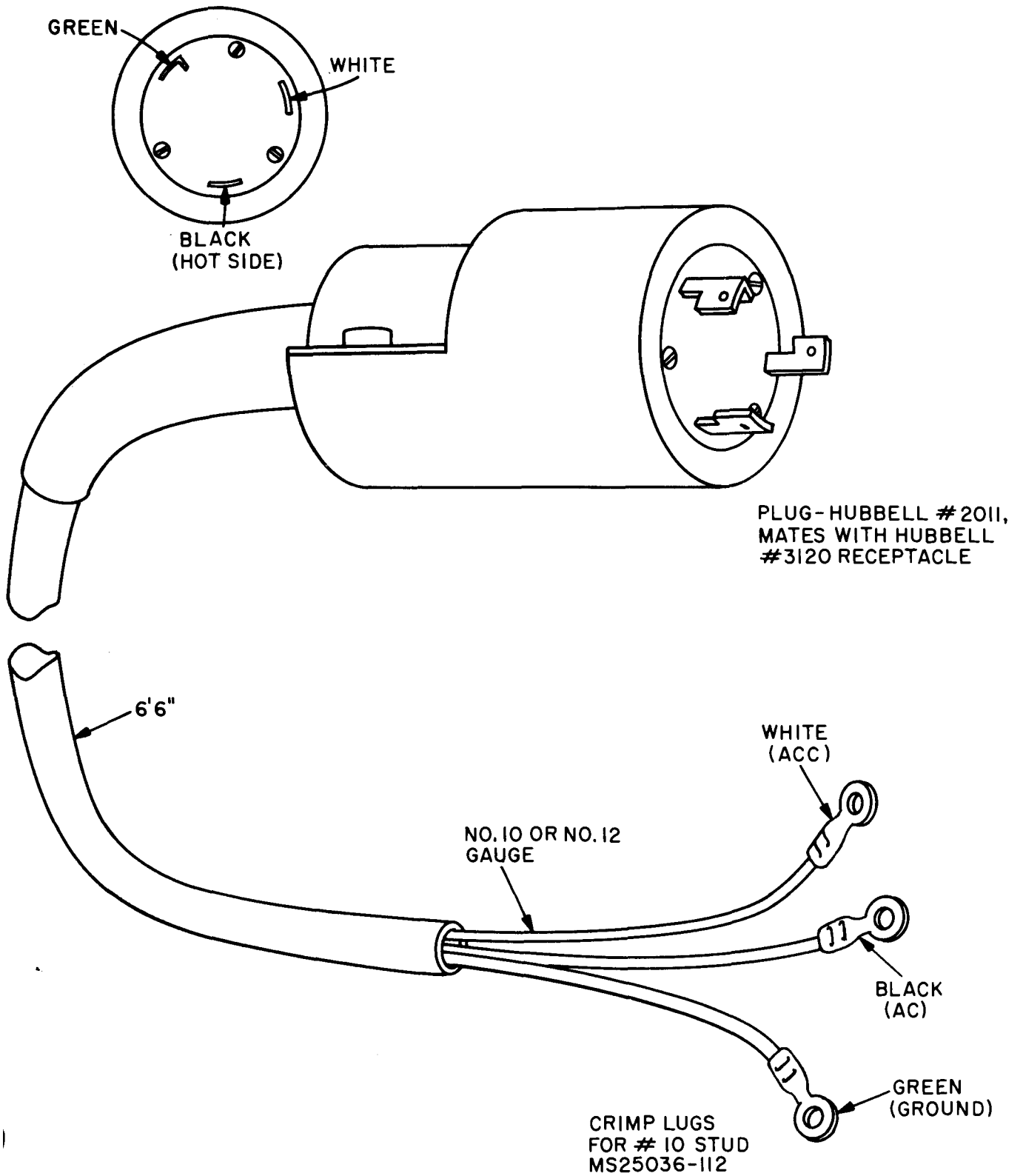

Figure 2-5. Power Cable

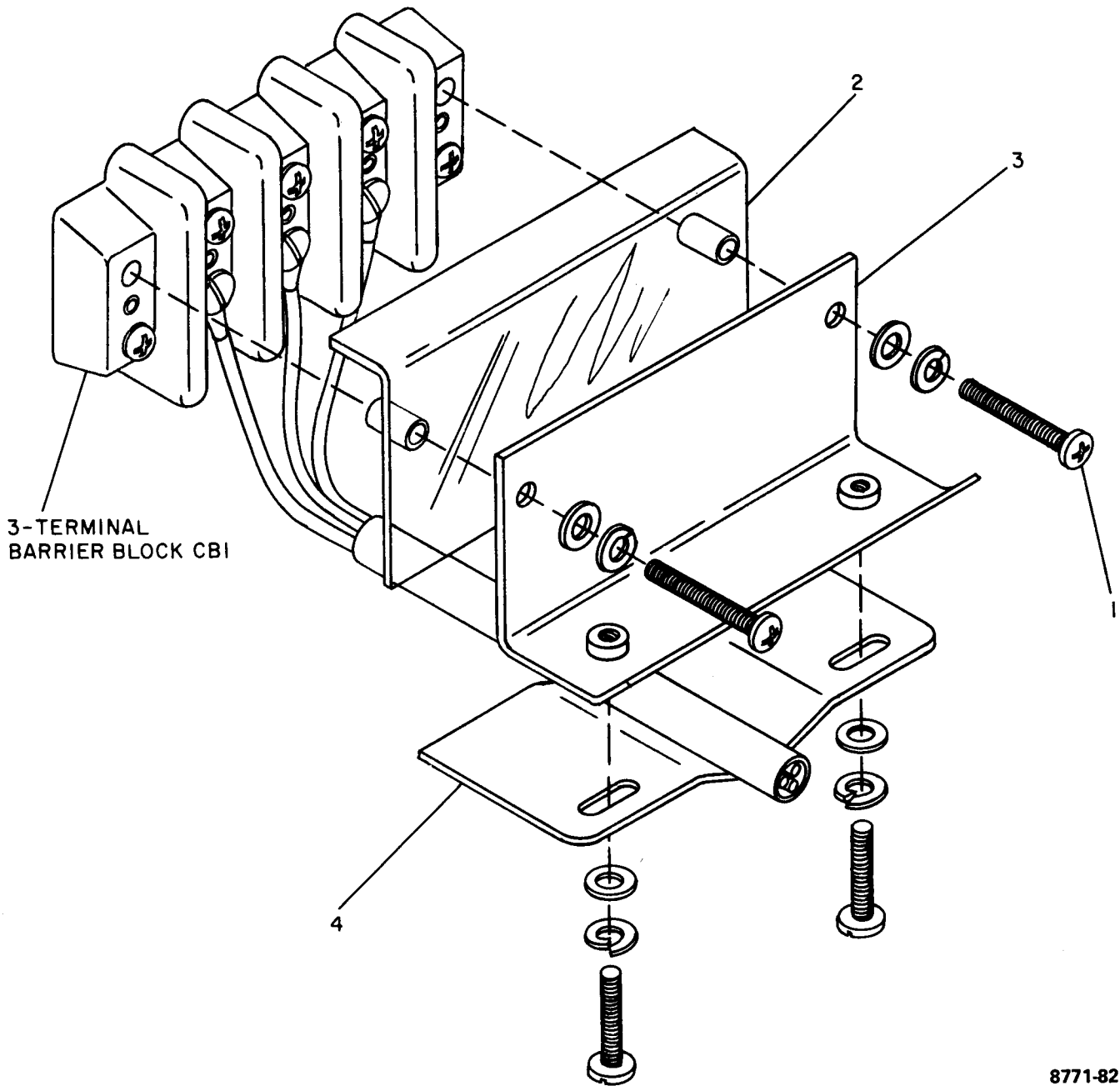

Figure 2-6. AC Power Cable Strain Relief Assembly

### SECTION III OPERATING INSTRUCTIONS

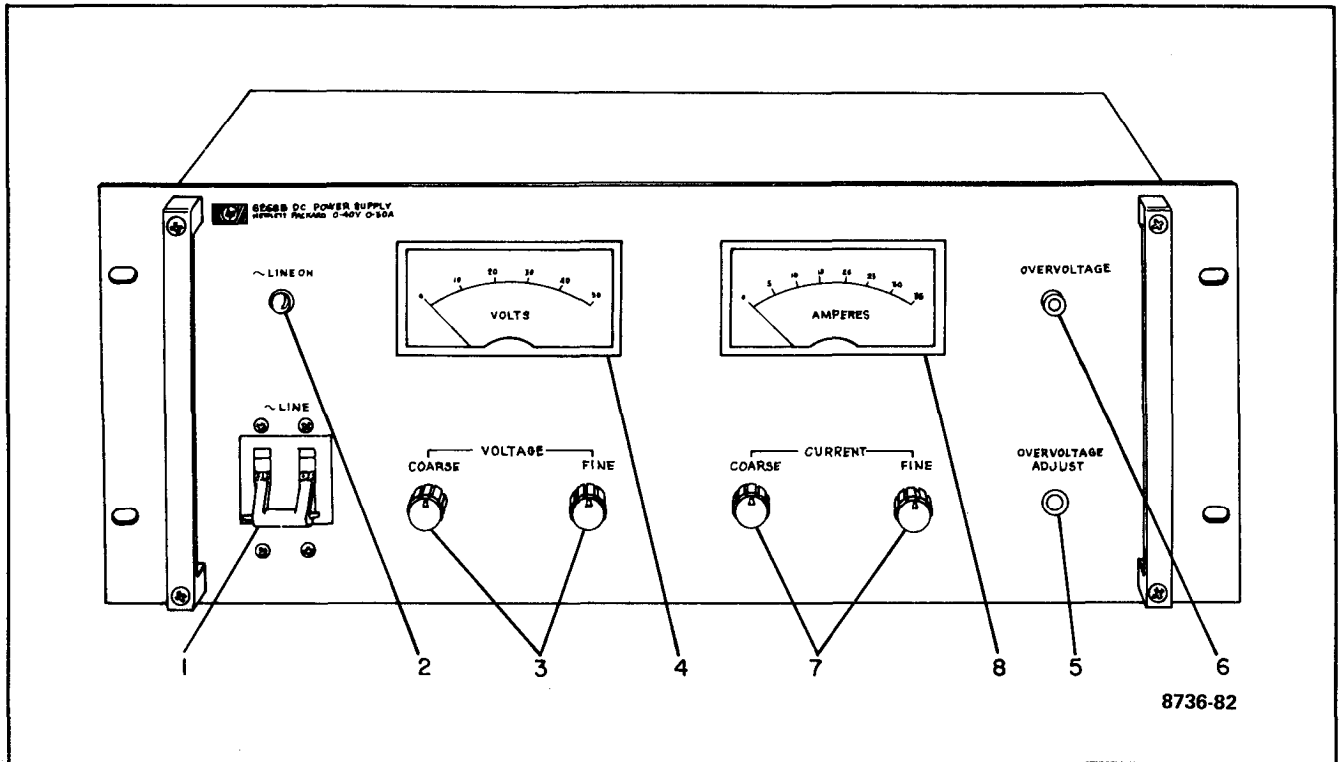

Figure 3-1. Front Panel Controls and Indicators

#### 3-1 TURN-ON CHECKOUT PROCEDURE

#### WARNING

3-2 The following steps describe the use of the front panel controls and indicators illustrated in Figure 3-1 and serve as a brief check that the supply is operational. This checkout procedure or the more detailed performance test of paragraph 5-5 should be followed when the instrument is received and before it is connected to any load equipment. Proceed to the more detailed test and troubleshooting procedures in Section V if any difficulties are encountered.

a. Turn CURRENT controls (7) and OVERVOLTAGE ADJUST potentiometer (5) fully clockwise and check that rear panel straps are connected as shown in Figure 3-2, but do not connect load  $R_L$ .

b. Connect ac power of the appropriate voltage and frequency to the rear panel ac and acc terminals. The supply's input rating is identified on its rear panel.

*Do not interchange the ac and acc input lines; connect the ac input terminal to the hot side and the acc input terminal to the grounded side of the ac line. Do not fail to connect the input ground terminal (  $\perp$  ) securely to an external earth ground.*

c. Set LINE switch or circuit breaker (1) ON and observe that pilot lamp (2) lights.

d. Adjust COARSE and FINE VOLTAGE controls (3) for desired indication on voltmeter (4).

e. Ensure that overvoltage crowbar circuit is operational by slowly turning OVERVOLTAGE ADJUST control (5) counterclockwise with a screwdriver until OVERVOLTAGE lamp (6) lights and voltmeter indication drops to zero volts.

f. Reset crowbar by returning OVERVOLTAGE ADJUST control to its maximum clockwise position and turning off the supply. On turning the supply back on, the voltage should be the same value as was set in step (d).

g. To check the constant current circuit, first turn off the supply, connect a short across the output bus bars (see Figure 3-2), and turn it back on.

h. Adjust COARSE and FINE CURRENT controls until ammeter indicates desired output current or current limit. (The VOLTAGE controls must be set for a greater-than-zero output to obtain the output current programmed.)

i. Turn off the supply, remove the short from its output, and read the remainder of these operating instructions before connecting the supply to an actual load.

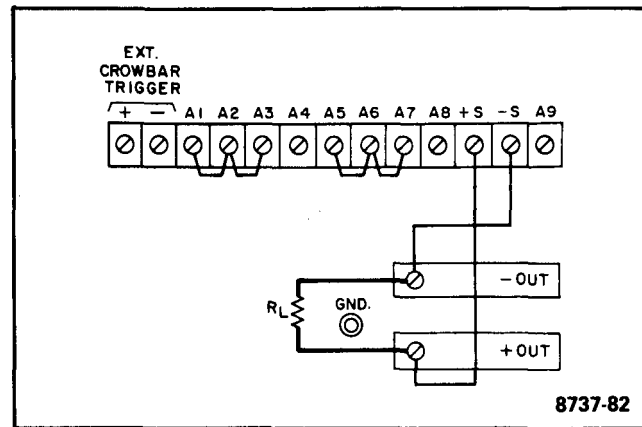

Figure 3-2. Normal Strapping Pattern

### 3-3 OPERATING MODES

3-4 This power supply is designed so that its mode of operation can be selected by making strapping connections between terminals on its rear panel. The following paragraphs first describe normal operation using the normal strapping pattern as it is connected at the factory.

3-5 Later paragraphs cover some optional operating modes including remote voltage sensing, remote programming, and some methods of operating these power supplies in combinations of two or three.

### 3-6 NORMAL OPERATING MODE

3-7 This power supply was shipped with the proper rear panel strapping connections made for constant-voltage/constant-current operation with local sensing and local programming. This strapping pattern is illustrated in Figure 3-2. In the constant-voltage mode, the power supply acts to maintain its output voltage constant in spite of changes in load, line, temperature, etc. Thus, for a change in load resistance, the output voltage of this mode remains constant while the output current changes by whatever amount necessary to accomplish this. In the constant-current mode, the power supply acts to maintain its output current constant in spite of changes in load, line, temperature, etc. Thus, for a change in load resistance, the output current remains constant while the output voltage changes by whatever amount necessary to accomplish this. By means of the front panel voltage and current controls, the operator selects either a constant-voltage or a constant-current output. Whether the supply functions in the constant-voltage or the constant-current mode depends on the settings of the voltage and current controls and on the resistance of the output load. For values of load resistance greater than a critical crossover value equal to the voltage setting divided by the current setting, the supply operates in the constant-voltage mode. With a load resistance smaller than this critical value, it operates in the constant-current mode. The transition occurs automatically; no switches need to be operated or connections changed.

### 3-8 Constant Voltage Operation

3-9 To adjust the supply for constant voltage operation:

a. Turn on supply and, with output terminals open, adjust the VOLTAGE controls for the desired output voltage. Then turn power off.

b. Connect a short across the rear panel output terminals, restore power, and adjust the CURRENT controls for the desired maximum output current. Then remove the short. If a load change causes this current limit to be exceeded, the supply automatically crosses over to constant current operation at this preset current limit and the output voltage drops proportionately. In setting the current limit, make an adequate allowance for high peak currents that could cause unwanted crossover. (Refer to paragraph 3-77.)

### 3-10 Constant Current Operation

3-11 To adjust the supply for constant current operation:

a. Connect a short across the rear output terminals, turn the power on, and adjust the CURRENT controls for the desired output current.

b. Open the output terminals and adjust the VOLTAGE controls for the desired maximum output voltage. If a load change causes this voltage limit to be exceeded, the supply automatically crosses over to constant voltage operation at this preset voltage limit and the output current drops proportionately. In setting the voltage limit, make an adequate allowance for high peak voltages that could cause unwanted crossover. (Refer to paragraph 3-77.)

### 3-12 Overvoltage Trip Point Adjustment

3-13 The crowbar trip voltage is adjusted by using the screwdriver control on the front panel. The approximate trip voltage ranges are listed in Table 1-1. When the crowbar trips, an SCR shorts the output and the amber OVER-VOLTAGE indicator on the front panel lights. Rotating the control clockwise sets the trip voltage higher. (It is set to maximum at the factory.) Paragraph 5-104 contains the procedure for adjusting the trip voltage, while paragraph 5-108 contains instructions for completely disabling the crowbar, if this is desired.



3-14 When adjusting the crowbar trip point, the possibility of false tripping must be considered. If the trip voltage is set too close to the supply's operating voltage, a transient in the output would falsely trip the crowbar. For this reason it is recommended that the crowbar be set higher than the output voltage by 5% of the output voltage plus 2 volts for the Models 6259B, 6260B, or 6261B, or 5% of the output voltage plus one volt for the Models 6268B or 6269B. If an occasional tripping of the crowbar can be tolerated as a load is being disconnected, the crowbar trip point can be set much closer to the operating voltage of the supply.

### 3-15 Connecting The Load

3-16 To satisfy the requirements of safety, the wires to the load should be at least heavy enough not to overheat while carrying the power supply current that would flow if the load were shorted. Generally, heavier wire than this is required to obtain good regulation at the load. If the load regulation is critical, use remote voltage sensing. (Refer to paragraph 3-27.)

3-17 If multiple loads are connected to one supply, each load should be connected to the supply's output terminals using separate pairs of connecting wires. This minimizes mutual coupling effects between loads and takes full advantage of the supply's low output impedance. Each pair of connecting wires should be as short as possible and twisted or shielded to reduce noise pickup.

3-18 If load considerations require the use of output distribution terminals that are located remotely from the supply, then the power supply output terminals should be connected to the remote distribution terminals by a pair of twisted or shielded wires and each load should be separately connected to the remote distribution terminals. Remote voltage sensing would be required under these circumstances. (Refer to paragraph 3-27.)

3-19 Either positive or negative voltages can be obtained from this supply by grounding one of the output terminals or one end of the load. Always use two wires to connect the load to the supply regardless of where or how the system is grounded. Never ground the system at more than one point. This supply can be operated up to 300 volts above ground if neither output terminal is grounded.

### 3-20 Operation With No Load

3-21 When the supply is operated without a load, its down-programming speed is considerably slower than when its output is loaded. This slower programming speed is evident whether the VOLTAGE controls are turned fully counterclockwise or an external voltage programming input

signal is decreased. When the crowbar is activated during no-load operation, the supply's output falls rapidly to about two volts and then decreases more slowly towards zero. The actual time required for the output to fall from two volts to zero varies from several seconds to several minutes, depending on the output rating of the supply.

### 3-22 Operation Beyond Rated Output

3-23 The supply may be able to provide voltages and currents greater than its rated maximum outputs. Operation can extend into the shaded areas on the meter face without damage to the supply, but performance cannot be guaranteed to meet all specifications.

### 3-24 OPTIONAL OPERATING MODES

3-25 The optional operating modes discussed in the following paragraphs include:

- a. Remote voltage sensing
- b. Remote programming
- c. Auto-Parallel operation
- d. Auto-Series operation
- e. Auto-Tracking operation

Special operating instructions for instruments equipped with Option 040 to permit their interfacing with a Model 6940B Multiprogrammer or a 6941B Multiprogrammer Extender are not included but can be found in the manual covering the programmable resistance cards that are necessary to complete the interface. Special calibration instructions for power supplies equipped with Option 040 are included in Section V of this manual. In the following paragraphs, all resistors are located on the printed circuit board A1 unless otherwise noted.

3-26 By changing its rear panel strapping pattern according to the instructions which follow, any of the supplies covered by this manual can be operated in any of the modes listed above.

#### **WARNING**

*Disconnect input ac power before changing any rear panel connections and make certain all wires and straps are properly connected and terminal strip screws are securely tightened before reapplying power.*

### 3-27 Remote Voltage Sensing

3-28 Because of the unavoidable voltage drop developed in the load leads, the normal strapping pattern shown in Figure 3-2 will not provide the best possible voltage regulation at the load. If, for example, one were to use 4-gauge wire to connect a load that

is located only 5 feet from a Model 6268B, 0-40V 0-30A supply, the full-load regulation measured at the load would be about 75 millivolts as compared to the 4.2 millivolt regulation that could be measured at the supply's output terminals. Thus even relatively short load leads can cause a considerable degradation of the supply's performance. The remote sensing connections shown in Figure 3-3 improve the voltage regulation at the load by monitoring the voltage there instead of at the supply's output terminals. (The advantages of remote sensing apply only during constant voltage operation.)

3-29 As can be seen in Figure 3-3, remote sensing involves removing the +S and -S jumpers from the output terminals, connecting the load leads normally, and using a separate pair of wires to connect the +S and -S sensing terminals to the load. The following paragraphs discuss some precautions that should be observed when making a remote sensing installation.

**NOTE**

*The +S jumper is the one that links the +S terminal to the +OUT terminal when the supply's terminals are strapped for normal operation as shown in Figure 3-2. The -S jumper is the one that links the -S terminal to the -OUT terminal.*

3-30 The load leads should be of the heaviest practicable wire gauge, at least heavy enough to limit the voltage drop in each lead to 0.5 volt. This limitation is dictated by the adverse effect that a greater load lead voltage drop has on bias voltages within the supply when remote sensing is used. Twisting the load leads may help to minimize noise pick-up. While there are practical limitations on the distance that can separate a power supply from its load when using remote sensing, it isn't possible to define these limits precisely due to a variety of factors that are unique to each particular installation.

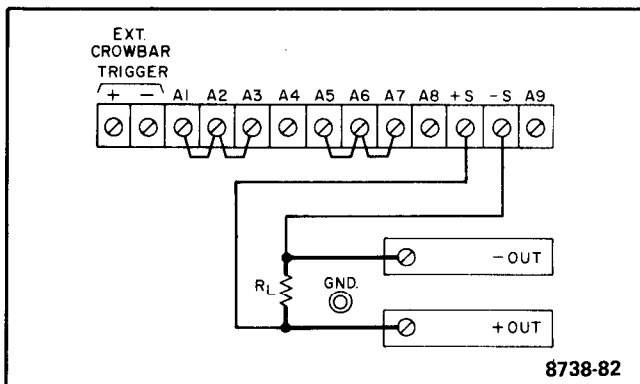

Figure 3-3. Remote Sensing

3-31 Since the sensing leads carry only a few milliamps, the wires used for sensing can be much lighter than the load leads (22 AWG is generally adequate), but they should be a shielded, twisted pair to minimize the pickup of external noise. Any noise picked up on the sensing leads will appear at the supply's output. The shield should be grounded at one end only and should not be used as one of the sensing conductors. The sensing leads should be connected as close to the load as possible.

3-32 The sensing leads are part of the supply's programming circuit, so they should be connected in such a way as to make it unlikely that they might inadvertently become open circuited. If the sensing leads were to open during operation, the output voltage would tend to rise. Although the increase would be limited by protective resistors R108 and R109, damage to the supply or to the load might occur if the loss of sensing were accompanied by a load transient. For this reason no switch, relay, or connector contacts should be included in the remote sensing path.

— CAUTION —

*When using remote voltage sensing, it is possible to damage the supply by disconnecting a load lead while the sensing lead is still connected and the supply is energized. If a load lead becomes disconnected, current flows through internal protection resistors R108 and R109, the sensing leads, and the load and may burn out the resistors. Additional factors could compound the damage caused by an opened load lead. If the output of the supply is connected to an inductive load or a battery \*, or is connected in parallel with another supply, then opening a load lead would allow current from the external source to flow through the sensing leads and damage the supply's input circuits. If the crowbar fires, the damage could even be greater.*

*For these reasons, if there is any risk of an opened load circuit while remote sensing is used, 1/16-amp fuses should be installed in both sensing leads. Fuses in the sensing leads will not affect the performance of the supply and should protect against costly damage.*

\* Remote sensing is not recommended when charging or discharging a battery. See paragraphs 3-87 and 3-91.

3-33 Another factor to be considered when making a remote sensing installation is the inductance of the long load leads. Although dc and low frequency performance are improved by remote sensing, the higher inductance of longer leads does impair tran-

sient response and could affect the stability of the feedback loop seriously enough to cause oscillation. If remote sensing disturbs the supply's stability, the calibration technician should try these two corrective measures:

a. Adjust the equalization control R47 until the oscillation stops. To achieve the best possible transient response for a given remote sensing installation, measure the transient response using the procedure given in paragraph 5-27 and adjust R47 while observing the transient response waveforms.

b. If adjusting R47 does not eliminate the instability, it may be beneficial to disconnect output capacitor A3C3 from the circuit and connect a similar capacitor directly across the load. To gain access to capacitor A3C3, the A2 RFI Assembly must first be removed. Follow steps (a) through (c) of paragraph 5-65 to remove the A2 assembly. Then unsolder the heavy wire from the A3 circuit board that connects the positive terminal of A3C3 to the positive output bus bar. (This heavy connecting point is identified in Figure 6-2.)

**NOTE**

*Do not unsolder the capacitor's negative lead. The negative lead to A3C3 carries collector current for transistor A4Q101 and would disable the power supply if disconnected.*

Tape the free end of the disconnected wire, replace the A2 assembly, and replace the bottom cover of the supply. The substitute capacitor should have approximately the same capacitance, an equal or greater voltage rating, and good high frequency characteristics. Connect it directly across the load using the shortest possible leads. Readjust equalization control R47 as in step (a) above after installing the substitute output capacitor.

**3-34 Remote Programming**

3-35 The output voltage or current of these power supplies can be remotely controlled by connecting an external resistor or applying an external voltage to rear panel terminals. If resistance programming is used, a variable resistor can control the output over its entire range. Or, a variable resistor connected in series with a fixed resistor can have its control restricted to a limited portion of the output range. Alternately, a switch can be used to select fixed values of programming resistance to obtain a set of discrete voltages or currents. (The switch must have make-before-break contacts to avoid producing the output voltage transients that momentarily opening the programming terminals would cause.) To maintain the temperature and stability specifications of the supply, programming resistors must be stable, low noise resistors with a temperature coefficient of less than 30ppm per °C and a power rating at least 30 times what they will actually dissipate.

3-36 Both voltage and current outputs can also be controlled through a voltage input. When voltage programming the output voltage, the choice can be made between using a connection that produces a unity gain relationship between input and output (paragraph 3-41) or another connection that produces variable voltage gains (paragraph 3-42). Similarly, the output current can be programmed using a connection that produces a fixed gain (paragraph 3-47) or a variable gain (paragraph 3-48).

3-37 Connecting a supply for remote voltage or current programming disables the corresponding front panel controls.

3-38 The following paragraphs discuss in greater detail the methods of remotely programming the output voltage or current using either a resistance or a voltage input. Whichever method is used, the wires connecting the programming terminals of the supply to the remote programming device must be shielded to reduce noise pickup. The outer shield of the cable should not be used as a conductor but should be connected to ground at one end only. All resistors are located on the main printed circuit board unless otherwise noted.

**3-39 Constant Voltage Output, Resistance Input.** The rear panel connections shown in Figure 3-4 allow the output voltage to be varied by using an external resistor to program the supply. The supply's constant voltage programming current determines its programming coefficient. In the supplies covered by this manual, this programming current is factory adjusted to within 1% of 5mA, resulting in a programming coefficient of 200 ohms per volt. If a greater programming accuracy is required, it can be obtained either by changing resistor R3 as discussed in paragraph 5-86 or, if the instrument is equipped with Options 020 or 022, by adjusting potentiometer R112 as discussed in paragraph 5-87. (See Figs. 6-1 through 6-8.)

3-40 With the programming terminals shorted (terminals A2 to -S), the no-load output voltage of the supply should be -15mV ±5mV. If a minimum output voltage is required that is closer to zero than this, it can be obtained either

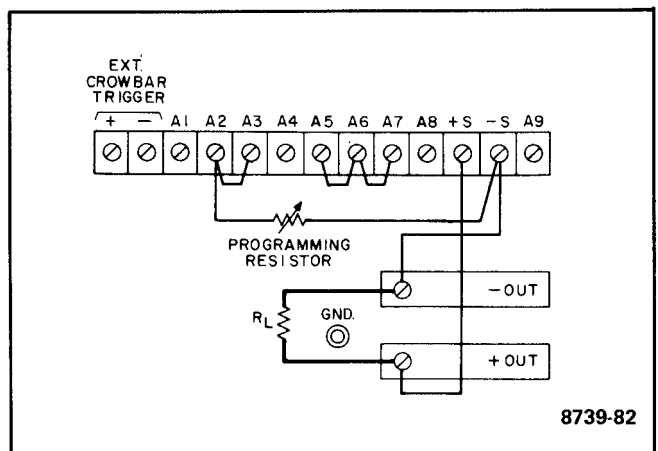

Figure 3-4. Resistance Programming of Output Voltage

by installing and adjusting R110 as discussed in paragraph 5-81 or, if the instrument is equipped with Option 020 or 022, by adjusting potentiometer R113 as discussed in paragraph 5-83.

— CAUTION —

Do not allow programming terminals A2 or -S to become open circuited while resistance programming the output voltage. If they do become open circuited, the supply's output voltage tends to rise beyond its rated maximum. If the supply's current controls and over-voltage crowbar trip point are properly adjusted, however, no damage to the power supply or load should result.

**3-41 Constant Voltage Output, Voltage Input (Unity Gain).** The rear panel connections shown in Figure 3-5 allow the output voltage to be varied by using an external voltage source to program the supply. In this mode, the output voltage varies in a 1 to 1 ratio with the programming voltage. The load on the programming voltage source is less than 20 microamperes. Impedance matching resistor  $R_x$  is required to maintain the temperature coefficient and stability specifications of the supply. To adjust the output voltage to exactly zero with a zero programming voltage, follow the same instructions as are referred to in paragraph 3-40. (See Figures 6-7 and 6-8.)

**3-42 Constant Voltage Output, Voltage Input (Variable Gain).** In the remote programming arrangement shown in Figure 3-6, the series combination of external voltage source  $E_s$  and reference resistor  $R_R$  replaces the supply's internal voltage programming current source. As a result, the voltage this external current source develops across gain control  $R_p$  becomes the output voltage of the supply, and the gain relationship between  $E_s$  and the output voltage equals the resistance ratio  $R_p/R_R$ .

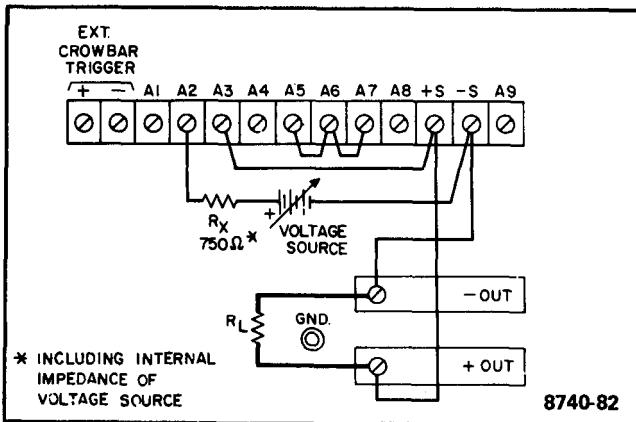

Figure 3-5. Voltage Programming of Output Voltage (Unity Gain)

3-43 When using this programming technique, select a value for  $R_R$  that is less than 10k ohms and that would conduct at least 5 milliamps if connected across the programming voltage source with its voltage at the maximum value of input voltage to be used. Once the value for  $R_R$  is selected, multiply  $R_R$  by the maximum voltage gain desired to find  $R_p$ . (If desired, the power supply's front panel voltage controls can be used in place of external gain control  $R_p$  by deleting the external gain control from the circuit and strapping together terminals A1 and A2.)

3-44 The output voltage of the supply can be adjusted to exactly zero with a zero programming voltage input either by installing and adjusting R111 as discussed in paragraph 5-82 or, if the instrument is equipped with Option 020 or 022, by adjusting potentiometer R112 as discussed in paragraph 5-63.

NOTE

The negative lead of the capacitor must not be unsoldered. Removing this lead will cause the supply to stop functioning because the lead carries the collector current of transistor A4Q101.

**3-45 Constant Current Output, Resistance Input.** The rear panel connections shown in Figure 3-7 allow the output current to be varied by using an external resistor to program the supply. The supply's constant current programming current, which is factory adjusted to 2.5mA  $\pm$ 10%, determines the exact value of its programming coefficient. The programming coefficients for the supplies included in this manual are as follows:

Models	6259B	4 ohms/ampere
	6260B	2 ohms/ampere
	6261B	4 ohms/ampere
	6268B	6 ohms/ampere
	6269B	4 ohms/ampere

if the  $\pm$ 10% accuracy of these coefficients is not adequate,

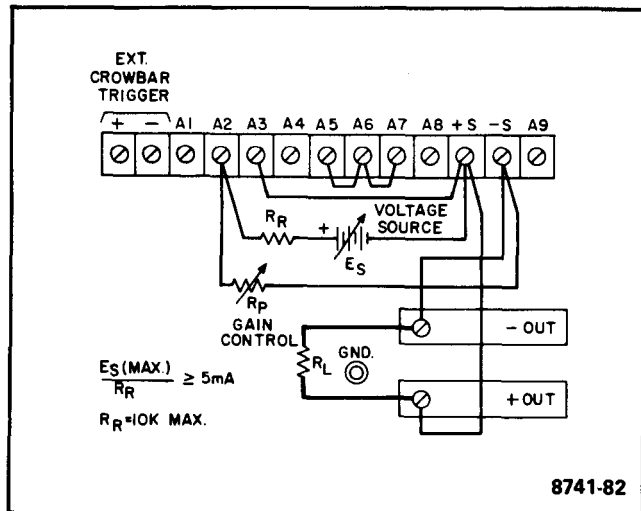

Figure 3-6. Voltage Programming of Output Voltage (Variable Gain)

they may be adjusted either by changing resistor R30 as discussed in paragraph 5-96 or, if the instrument is equipped with Option 021 or 022, by adjusting potentiometer R116 as discussed in paragraph 5-97.

3-46 With zero ohms connected across the programming terminals, the output current of the supply may be set to exactly zero either by installing and adjusting R117 as described in paragraph 5-91 or, if the instrument is equipped with Option 021 or 022, by adjusting potentiometer R119 as discussed in paragraph 5-93.

— CAUTION —

*Do not allow programming terminals A4 or A6 to become open-circuited while resistance programming the output current. If they do open, the supply's output current rises to a value that may damage the supply or the load. If in the particular programming configuration used there is a chance that the terminals might open, we suggest that a 200 ohm resistor be connected across the programming terminals. Of course, when this resistor is used, the resistance value actually programming the supply is the parallel combination of the remote programming resistance and the resistor across the programming terminals. Like the programming resistor, this resistor should be a low noise, low temperature coefficient type.*

**3-47 Constant Current Output, Voltage Input (Fixed Gain).** The rear panel connections shown in Figure 3-8 allow the output current to be varied by using an external voltage source to program the supply. The constant-current programming coefficients for the supplies included in this manual are as follows ( $\pm 10$ ):

- Model 6259B 10.0mV/ampere
- 6260B 5.0mV/ampere
- 6261B 10.0mV/ampere
- 6268B 16.7mV/ampere
- 6269B 10.0mV/ampere

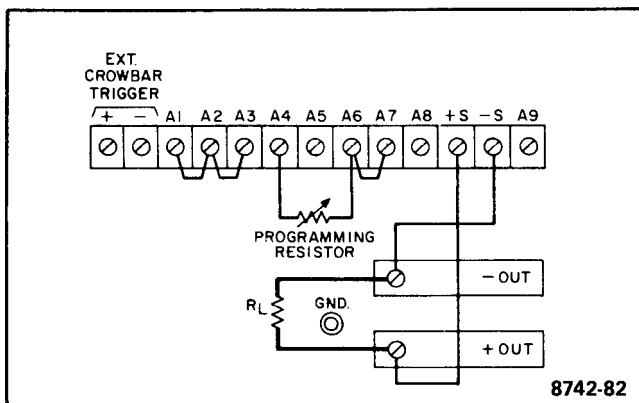

Figure 3-7. Resistance Programming of Output Current

The load on the programming voltage source is less than 20 microamperes. The programming voltage required to obtain maximum rated current from these supplies is about 500 millivolts. An input greater than 600mV may damage the instrument through excessive power dissipation. Impedance matching resistor  $R_x$  is required to maintain the temperature coefficient and stability specifications of the supply. To adjust the output current to exactly zero with a zero programming voltage, follow the same instructions as are referred to in paragraph 3-46.

**3-48 Constant Current Output, Voltage Input (Variable Gain).** In the remote programming arrangement shown in Figure 3-9, the series combination of external voltage source  $E_s$  and reference resistor  $R_r$  replaces the supply's internal current programming source. As a result, the voltage this external current source develops across gain control  $R_p$  becomes the reference against which the voltage drop across the output current sampling resistor is compared by the constant-current comparator. The relationship between  $E_s$  and the supply's output current depends on the resistance ratio  $R_p/R_r$  and on the constant-current programming coefficient ( $K_p$ ) of the supply. (These coefficients are given in paragraph 3-47.) The relationship between input voltage and output current is

$$I_{OUT} = (E_S \times R_P) / (K_P \times R_R).$$

3-49 When using this programming technique, select a value for  $R_r$  that is less than 10k ohms and that would conduct at least 2.5 milliamps if connected across the programming voltage source with its voltage at the maximum value of input voltage to be used. once the value for  $R_r$  is selected, multiply it by  $K_p \times I_{out}(\max) / E_s(\max)$  to find  $R_p$ . (If desired, the power supply's front panel current controls can be used in place of external gain control  $R_p$  by deleting the external gain control from the circuit and strapping together terminals A5 and A6.)

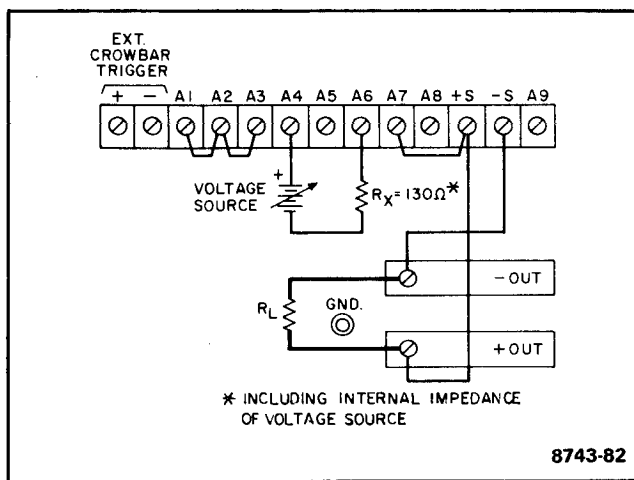

Figure 3-8. Voltage Programming of Output Current (Fixed Gain)

3-50 The output current of the supply can be adjusted to exactly zero with a zero programming voltage input either by installing and adjusting R115 as discussed in paragraph 5-92 or, if the instrument is equipped with Option 021 or 022, by adjusting potentiometer R116 as discussed in paragraph 5-94 (See Figure 6-7)

### 3-51 Auto-Parallel Operation

3-52 Use the rear panel interconnections shown in Figure 3-10 or 3-11 to auto-parallel two or three supplies. This mode of operation provides a greater current capacity than can be obtained from a single supply while maintaining nearly equal load sharing among the paralleled supplies under all load conditions. Supplies having the same model number make the most practical auto-parallel combinations, but any of the supplies included in this manual that have equal current ratings may be used.

#### NOTE

*Use wires of equal length and gauge to connect each auto-paralleled supply to the load. Load sharing accuracy is affected unless the positive leads connecting each supply to the load are all equal in resistance.*

3-53 **Setting the Voltage and Current Controls.** The auto-parallel combination of two or three supplies behaves as if it were a single constant-voltage/constant-current supply controlled by the voltage and current controls of the master supply. The voltage controls of the slave(s) are disabled, but their current controls remain operative and must be set to maximum to prevent a slave supply from independently reverting to constant current operation as would occur if the output current setting of the master supply exceeded that of a slave.

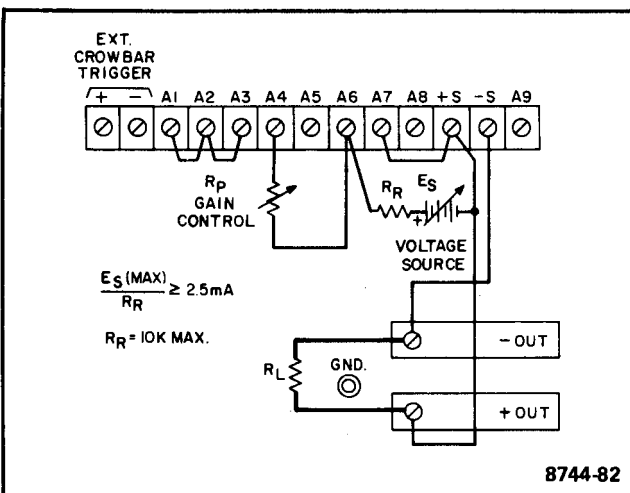

Figure 3-9. Voltage Programming of Output Current (Variable Gain)

3-54 **Overvoltage Protection in Auto-Parallel.** The interconnections shown in Figures 3-10 and 3-11 between the external crowbar trigger terminals on the master and on the slave(s) must be made to permit the overvoltage crowbar in the master to fire the SCRs in the master and the slave(s) if an overvoltage condition occurs. Be sure to connect them with correct polarity, plus to plus and minus to minus. Set the slave supply overvoltage potentiometer(s) to maximum (clockwise) to disable them, and adjust the overvoltage trip point at the master supply.

3-55 **Auto-Parallel With Remote Sensing.** To combine auto-parallel operation with remote sensing, connect the supplies as described above but remove the +S and -S jumpers from the master supply and connect the +S and -S terminals directly to the (+) and (-) ends of the load. Observe the precautions outlined under paragraph 3-27.

3-56 **Auto-Parallel With Remote Programming.** When two or three supplies are connected in auto-parallel, their combined output voltage, current, or both can also be remotely programmed. Refer to the appropriate sections of paragraph 3-34 for the additional rear panel connections required and make these connections to the master supply only. Observe all precautions outlined in the paragraphs on remote programming. The simultaneous use of remote sensing and remote programming is also possible during auto-parallel operation.

### 3-57 Auto-Series Operation

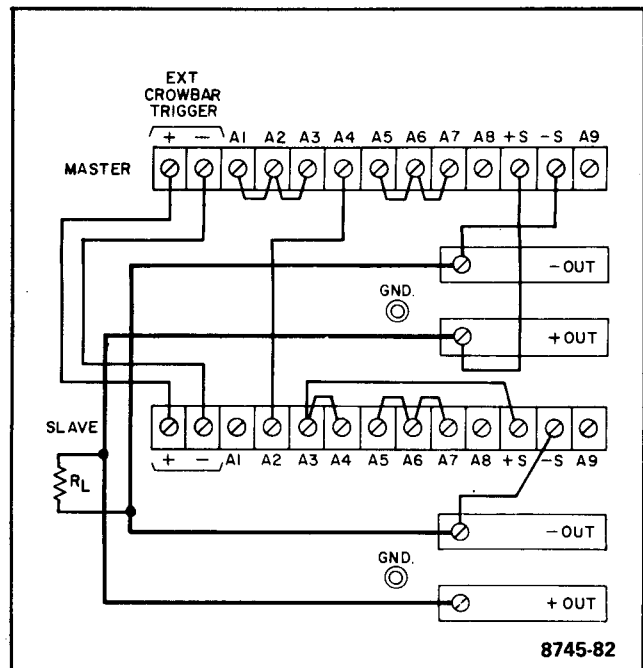

Figure 3-10. Auto-Parallel Operation of Two Units

3-58 Figures 3-12 and 3-13 show the rear panel and circuit board interconnections required to operate two or three supplies in the auto-series mode. This mode of operation allows two or three series-connected supplies to be simultaneously programmed by the voltage and current controls of a master supply. The master supply must always be the one at the positive end of the series combination. The output voltage of each slave supply varies in direct proportion to that of the master and the ratio of each slave's output voltage to the master's is established by the settings of the slave supplies' voltage controls. The resulting combination of two or three supplies behaves as if it were a single constant-voltage/constant-current supply. The supply with the lowest current rating limits the maximum output current of the combination. Any of the supplies included in this manual can be used as an auto-series slave, and any well-regulated variable output supply can be used as the master.

3-59 In applications where coordinated positive and negative voltages are required, grounding the center tap of an auto-series combination of supplies allows simultaneous proportional control of both supply voltages.

**3-60 Determining the Value for  $R_x$ .** Each slave supply has an external resistor  $R_x$  associated with it that supplies its voltage programming current. If the temperature coefficient and stability specifications of the supplies are to be maintained, these must be stable, low noise resistors with a temperature coefficient of less than 30ppm per °C and a power rating at least 30 times what they will actually dissipate. The proper value for  $R_x$  (when using two units in auto-series) or for  $R_{x1}$  (for the first slave when using three units) is calculated by first finding the voltage programming current of the slave supply. This is calculated by referring to Table 1-1 for the remote voltage programming resistance control coefficient and taking its reciprocal. For example, the voltage programming current in the Model 6259B is  $1/(200\Omega/V)$  or 5mA. Next, divide this current into the maximum voltage rating of the master supply to determine  $R_x$  for the first slave. If our master supply were a zero-to-25-volt unit, for example,  $R_x$  or  $R_{x1}$  would be  $25V/5mA = 5000$  ohms.

3-61 When operating three supplies in auto-series, find  $R_{x2}$  by dividing the voltage programming current of the second slave, calculated as in paragraph 3-60, into the maximum voltage expected from the first slave.

**3-62 Setting the Voltage Controls.** The voltage each slave supply contributes is determined by its voltage control setting. The output voltage of the first slave supply tracks the voltage of the master, and the voltage of the second slave (if used) tracks the voltage of the first slave. For this reason, the voltage of the master must be adjusted to

maximum, and then each slave, in turn, must be set to the corresponding voltage desired during initial setup of the auto-series combination. Once this has been done, the total voltage of the combination can be controlled by the voltage controls of the master supply or it can be remotely programmed through the master supply.

**3-63 Setting the Current Controls.** Auto-series operation leaves the current controls of all supplies operative, but the supply whose current control has the lowest setting determines the point at which automatic crossover to constant current operation begins to lower its output voltage and thus that of the series combination. The constant current circuit of a supply has no effect on the outputs of the supplies connected in a more positive position in the series combination, but it does affect its own output and the outputs of the supplies connected in a more negative position. If the current controls of one of the slave supplies are set the lowest, then an overload or short circuit at the output will cause the master supply (or the master and the first slave) to force current through the reverse voltage protection diodes at the outputs of the downstream slaves. Because this current could be excessive either for the diodes

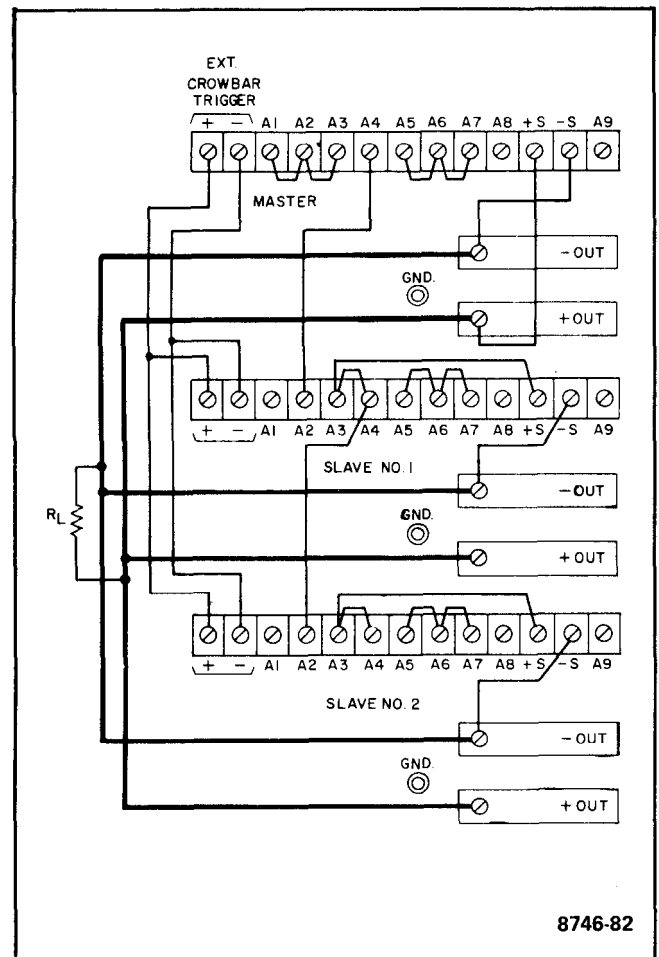

Figure 3-11. Auto-Parallel Operation of Three Units

or the load, the current controls of the slave supplies should be set to maximum and the master supply's current controls used to establish the output current or current limit.

**3-64 Overvoltage Protection in Auto-Series.** The interconnections shown in Figures 3-12 and 3-13 between the external crowbar trigger terminals on the master and on the slave(s) must be made to permit the overvoltage crowbar in any one of the interconnected supplies to fire the SCRs in all of them if an overvoltage condition occurs. Be sure to connect them with correct polarity, plus to plus and minus to minus. Set the overvoltage potentiometer in each supply so that it trips at a point slightly above the voltage that supply will contribute.

**3-65 Auto-Series With Remote Sensing.** To combine auto-series operation with remote sensing, connect the supplies as described above but remove the +S jumper from the master supply and the -S jumper from the last slave supply and connect the +S and -S terminals directly to the (+) and (-) ends of the load. Observe the precautions outlined under paragraph 3-27.

**3-66 Auto-Series With Remote Programming.** When two or three supplies are connected in auto-series, their combined output voltage, current, or both can also be remotely programmed. Refer to the appropriate sections of paragraph 3-34 for the additional rear panel connections required and make these connections to the master supply only. Observe all precautions outlined in the paragraphs on

remote programming. The simultaneous use of remote sensing and remote programming is also possible during auto-series operation.

**3-67 Auto-Tracking Operation**

3-68 Figures 3-14 and 3-15 show the rear panel interconnections required to operate two or three supplies in the auto-tracking mode. This mode of operation allows two or three supplies that share a common negative output bus to power separate loads and have their outputs simultaneously programmed by the voltage and current controls of a master supply. Unless their outputs are to be equal, the supply that is to have the greatest output voltage must be selected as the master. The output voltage of each slave supply remains a constant percentage of the master's with the percentage for each slave established by that slave's voltage control settings and the choice of its external programming resistor  $R_x$ . Any of the supplies included in this manual can be used as an auto-tracking slave, and any well-regulated variable output supply can be used as the master.

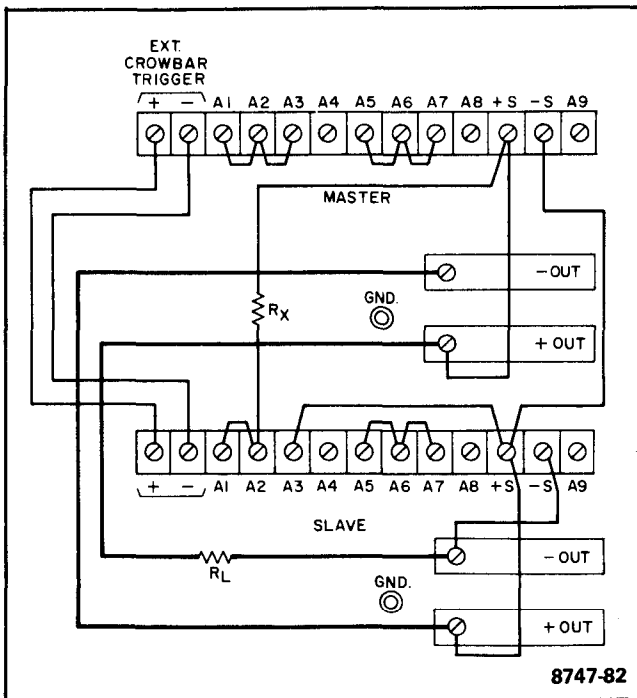

Figure 3-12. Auto-Series Operation of Two Units

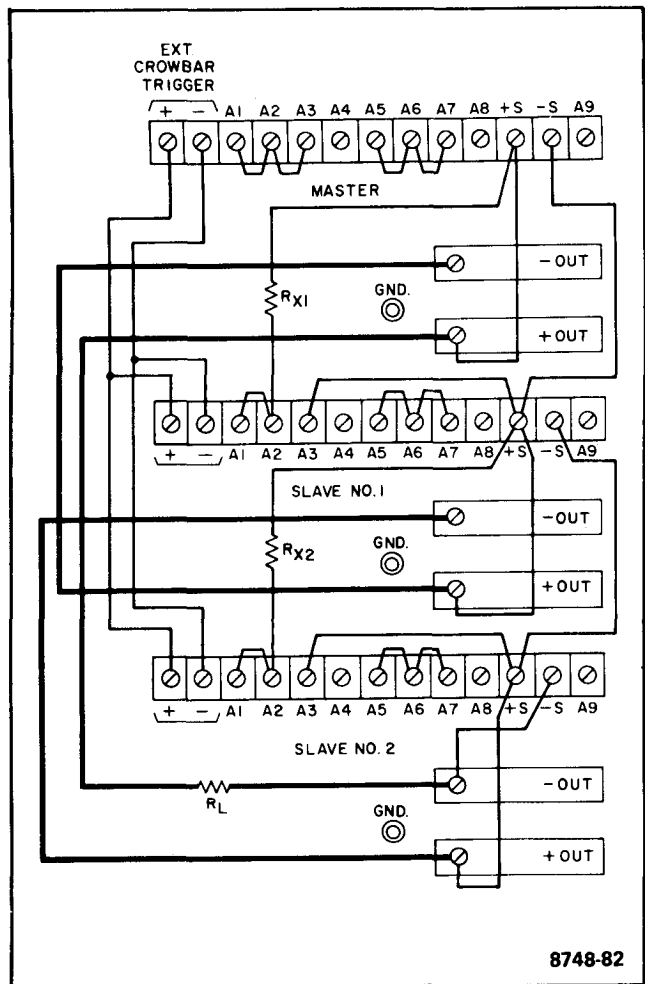

Figure 3-13. Auto-Series Operation of Three Units



**3-69 Determining the Value for  $R_x$ .** Each slave supply has an external resistor  $R_x$  associated with it that supplies its voltage programming current. If the temperature coefficient and stability specifications of the supplies are to be maintained, these must be stable, low noise resistors with a temperature coefficient of less than 30ppm per °C and a power rating at least 30 times what they will actually dissipate. To calculate the proper value for  $R_x$  for each slave, the following information is required:

- a.  $E_s$ , the rated maximum voltage of the master supply
- b.  $E_s$ , the corresponding maximum voltage desired of the slave supply with its voltage control set to maximum.
- c.  $R_p$ , the resistance of the slave supply's coarse voltage control.

The  $R_p$  values for the supplies included in this manual are as follows:

Model	6259B,	6260B	2.5kΩ
	6261B		5 k Ω
	6268B,	6269B	10kΩ

To find  $R_x$  use the formula:

$$R_x = (E_M R_p / E_S) - R_p$$

For example, if the slave supply is a Model 6259B and we want its output to vary from zero to 10 volts as the master supply varies from zero to 40 volts, the solution for  $R_x$  is:

$$R_x = (40V \times 2.5k\Omega / 10V) - 5k\Omega$$

$$R_x = 5k\Omega$$

**3-70** It is also possible to make an auto-tracking slave's voltage equal the output of the master supply. To do this, make a direct connection from the +S terminal of the master to the A2 terminal of the slave instead of using a programming resistor, and remove the slave's A1 to A2 jumper.

**3-71 Setting the Voltage and Current Controls.** The voltage control of each slave must be set fully clockwise to obtain the voltage ratios established by the formula for  $R_x$  given in paragraph 3-69. By lowering the settings of the slave's voltage controls, the voltage of the slave can be made a smaller percentage of the master supply's voltage. The current controls of all supplies in an auto-tracking combination are independently operative and can be used to set current limits for each individual load. If the master supply goes into constant current mode, the output voltages of the slaves continue to track that of the master. If a slave supply goes into constant current mode, however, no other supply is affected.

**3-72 Overvoltage Protection in Auto-Tracking.** Paralleling the crowbar circuits, as is required for the auto-parallel and auto-series modes, is optional in the auto-tracking mode. If the external trigger windings of transformer T90

in the master and in the slave supplies are not paralleled, the overvoltage protection circuit in each supply independently monitors the voltage across its own load. Then if the master supply crowbars, the output voltage of the slave(s) also decreases, but if one of the slaves crowbars, no other supply is affected.

**3-73** In order to have all supplies in an auto-tracking combination crowbar simultaneously if any of them has an overvoltage condition, parallel their crowbar circuits as shown in Figure 3-14 or 3-15. Set the overvoltage potentiometer in each supply so that it trips at a point slightly above the voltage that supply will provide.

**3-74 Auto-Tracking With Remote Sensing.** To combine auto-tracking operation with remote sensing, connect the supplies as described above but remove the +S and -S jumpers from each supply and connect the +S and -S terminals directly to the (+) and (-) ends of its load. Observe the precautions outlined under paragraph 3-27.

**3-75 Auto-Tracking With Remote Programming.** When two or three supplies are connected for auto-tracking operation, their output voltages can be remotely programmed but their currents cannot. Refer to the appropriate sections of paragraph 3-34 for the additional rear panel connections required and make these connections to the master supply only. Observe all precautions outlined in the paragraphs on remote programming. The simultaneous use of remote sensing and remote programming is also possible during auto-tracking operation.

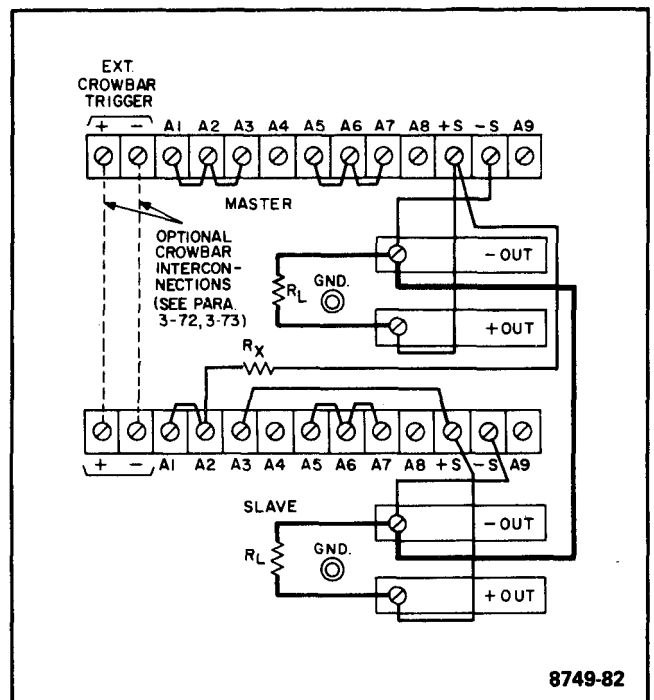

Figure 3-14. Auto-Tracking Operation of Two Units

### 3-76 SPECIAL OPERATING CONSIDERATIONS

#### 3-77 Pulse Loading

3-78 The power supply automatically crosses over from constant-voltage to constant-current operation, or the reverse, in response to an increase beyond the preset voltage or current limit. Although the preset limit may be set higher than the average output current or voltage, high peak currents or voltages may exceed the preset limit and cause crossover to occur. If this current or voltage limiting is not desired, set the current or voltage controls somewhat above the peak rather than the average requirement.

#### 3-79 Output Capacitance (Figure 6-2)

3-80 An internal capacitor (A3C3) connected across the output terminals of the supply helps to supply high-current pulses of short duration during constant voltage operation. Adding capacitance externally would improve the pulse current capability of the supply but would decrease the load protection provided by the constant-current circuit. A high-current output pulse could damage load components before the average output current is large enough to cause the constant-current circuit to operate. Another drawback to adding additional capacitance is the possibility of causing the supply to become unstable and oscillate.

3-81 During constant-current operation, additional capacitance connected across the output of the supply would have the following disadvantages:

- With additional capacitance connected, the output impedance of the supply decreases with increasing frequency.
- With additional capacitance connected, the output current takes longer to recover from the effects of a change in the load resistance.
- With additional capacitance connected, a rapid reduction in load resistance can produce a larger than normal surge current that could cause a high power dissipation in the load.

#### 3-82 Reverse Voltage Protection (Figure 6-5)

3-83 One or two internal diodes (A4CR106 or A4CR107) connected with reverse polarity across the output terminals of the supply protect the output electrolytic capacitors and series transistors from the effects of a reverse voltage applied across the supply's output. Such a reverse voltage might inadvertently be applied when operating supplies in series if one of them were to be turned on or off before the other. The current rating of the output diodes is equal to the rated output current of the supply.

3-84 The series regulator transistors are also protected against reverse voltage by diode A4CR105. This diode shunts the series regulators if the supply is connected in parallel with another supply but is deenergized.

#### 3-85 Reverse Current Loading

3-86 An active load connected to the power supply may actually deliver a reverse current to the supply during a portion of its operating cycle. If an external source is allowed to pump current into the supply, it will cause a loss of regulation and might possibly damage the output capacitor. To avoid these effects, it is necessary to pre-load the supply with a dummy load resistor so that it delivers current through the entire operating cycle of the load device.

#### 3-87 Battery Charging

3-88 The automatic crossover between constant-voltage and constant-current exhibited by these supplies makes them ideal for battery charging applications. Using this

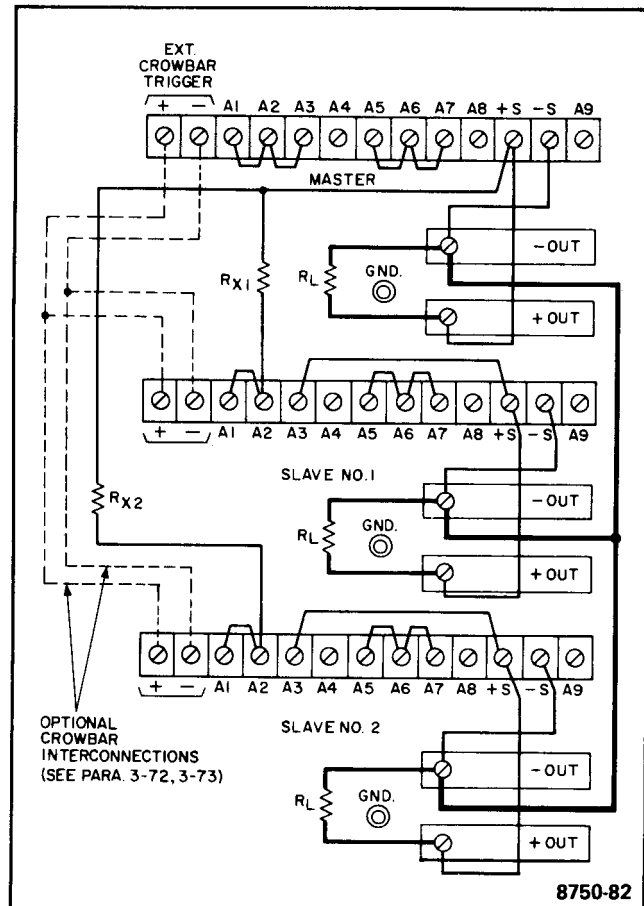

Figure 3-15. Auto-Tracking Operation of Three Units

feature, a battery may be charged at a constant-current until the maximum charge voltage is reached, at which point the supply reverts to constant-voltage operation and continues to supply a trickle charge current sufficient to maintain full charge. Thus, the charging operation can be unattended after properly setting the charging rate and maximum charge voltage and connecting the battery to the output terminals of the supply.

— CAUTION —

*Any time these supplies are used to charge a battery, be sure to install a protective diode CR<sub>p</sub> in series with the battery as shown in Figure 3-16 to prevent the battery from discharging into the supply if the supply is turned off. Extensive damage to the supply could result if this diode were omitted.*

*The use of remote voltage sensing provides no advantages when performing a constant-current battery charge as discussed in paragraph 3-89 or a taper charge as discussed in paragraph 3-90. Because of a serious risk of damage to the supply, the use of remote voltage sensing should not be attempted when charging (or discharging) a battery. Also see the CAUTION following paragraph 3-32.*

NOTE

*A large battery, connected as a load, presents a large capacitance to the output terminals. This capacitance could cause the supply to oscillate. If the supply appears unstable, it may be beneficial to readjust equalization control R<sub>47</sub> located on the main circuit board.*

**3-89 Constant-Current Charge.** To perform a constant-current battery charge, set the charging rate and full charge voltage as follows:

- a. Turn both the VOLTAGE and CURRENT controls fully counterclockwise (CCW).
- b. Connect a short circuit across the output terminals and rotate the VOLTAGE control fully clockwise (CW).
- c. Adjust the CURRENT control for the desired charging rate as read on the front panel ammeter.
- d. Rotate VOLTAGE control fully CCW and remove the short circuit.
- e. Adjust the VOLTAGE control for an output voltage 0.7 volts greater than the desired full charge voltage. (The added 0.7 volts compensates for the drop across CR<sub>p</sub>.) The supply may then be connected to the battery terminals, positive to positive and negative to negative as shown in Figure 3-16 (omit R<sub>T</sub>).

**3-90 Taper Charge.** When charging lead-acid cells, many manufacturers recommend that the charging current be reduced as the charge nears completion. This can be accomplished by inserting a small resistance (R<sub>T</sub>) in series with one of the load leads from the supply to the battery. (See Figure 3-16.) This resistor alters the normally rectangular charging plot in such a manner as to provide a taper charge for the last portion of the charge. The proper value for this resistor is the difference between the full charge voltage and the voltage at which the tapering is to start, divided by the initial charging current. Set the initial charging rate and full charge voltage as instructed in paragraph 3-89.

**3-91 Battery Discharging**

3-92 These power supplies are also useful when batteries must be discharged at a constant current in order to test them. Connecting a supply as shown in Figure 3-17 and following the instructions below makes an unattended constant-current discharge possible by automatically shutting off the output of the supply when the battery voltage reaches zero.

3-93 The supply operates in the constant-current mode, delivering the current set by the current control. This constant current flowing through dropping resistor R<sub>x</sub> produces a constant voltage across the resistor. Initially, the battery voltage is high and the supply's output voltage is low, but as the battery voltage decreases during discharge, the supply voltage increases. When the battery voltage reaches zero,

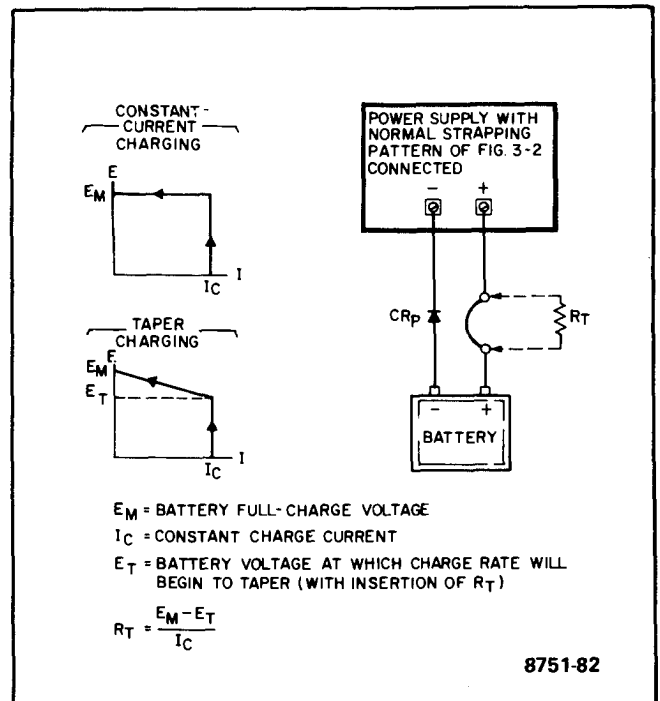

Figure 3-16. Battery Charging

the supply senses this through the connection to its A2 terminal and reduces the output current to zero. (If this automatic shutoff feature is not required, the 10k ohm resistor may be omitted.) As shown in Figure 3-17,  $R_x$  must be selected so that its IR drop is less than the maximum rated output voltage of the supply, but greater than the initial battery voltage.

3-94 To give a battery a constant-current discharge, proceed as follows:

- a. Turn off the power supply and disconnect the jumpers from terminal A1 to A2 and from A2 to A3. (This step disables the supply's VOLTAGE controls.)
- b. Connect terminal A3 to +S and leave all other jumpers connected as for normal operation as shown in Figure 3-17.
- c. Connect the positive terminal of the battery to A2 through a  $10k\Omega$  resistor.
- d. Connect the positive terminal of the supply to the negative terminal of the battery.
- e. Connect  $R_x$  between the negative terminal of the supply and the positive terminal of the battery, rotate the supply's current control fully counterclockwise (CCW), energize the supply, and set the current control for the desired discharge current as indicated on the front panel meter.

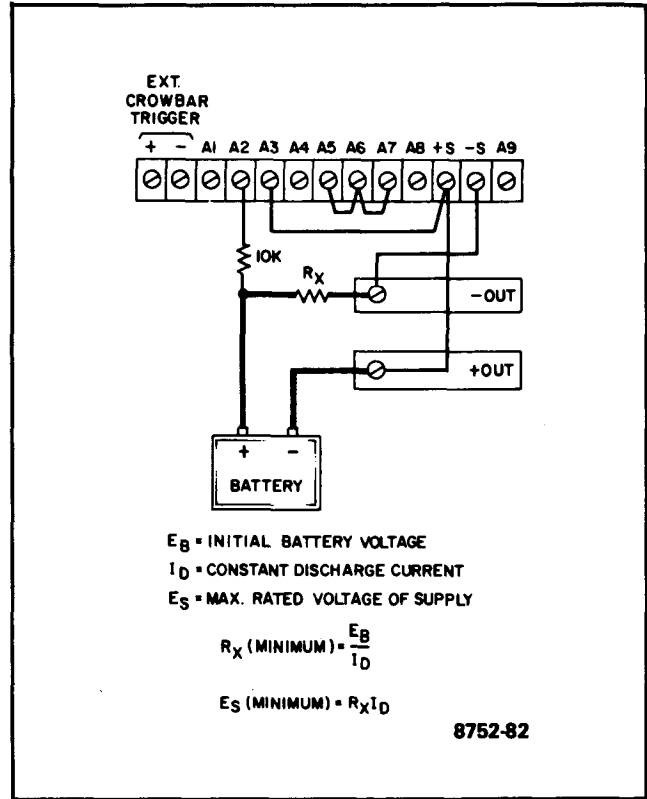

Figure 3-17. Battery Discharging

SECTION IV  
PRINCIPLES OF OPERATION

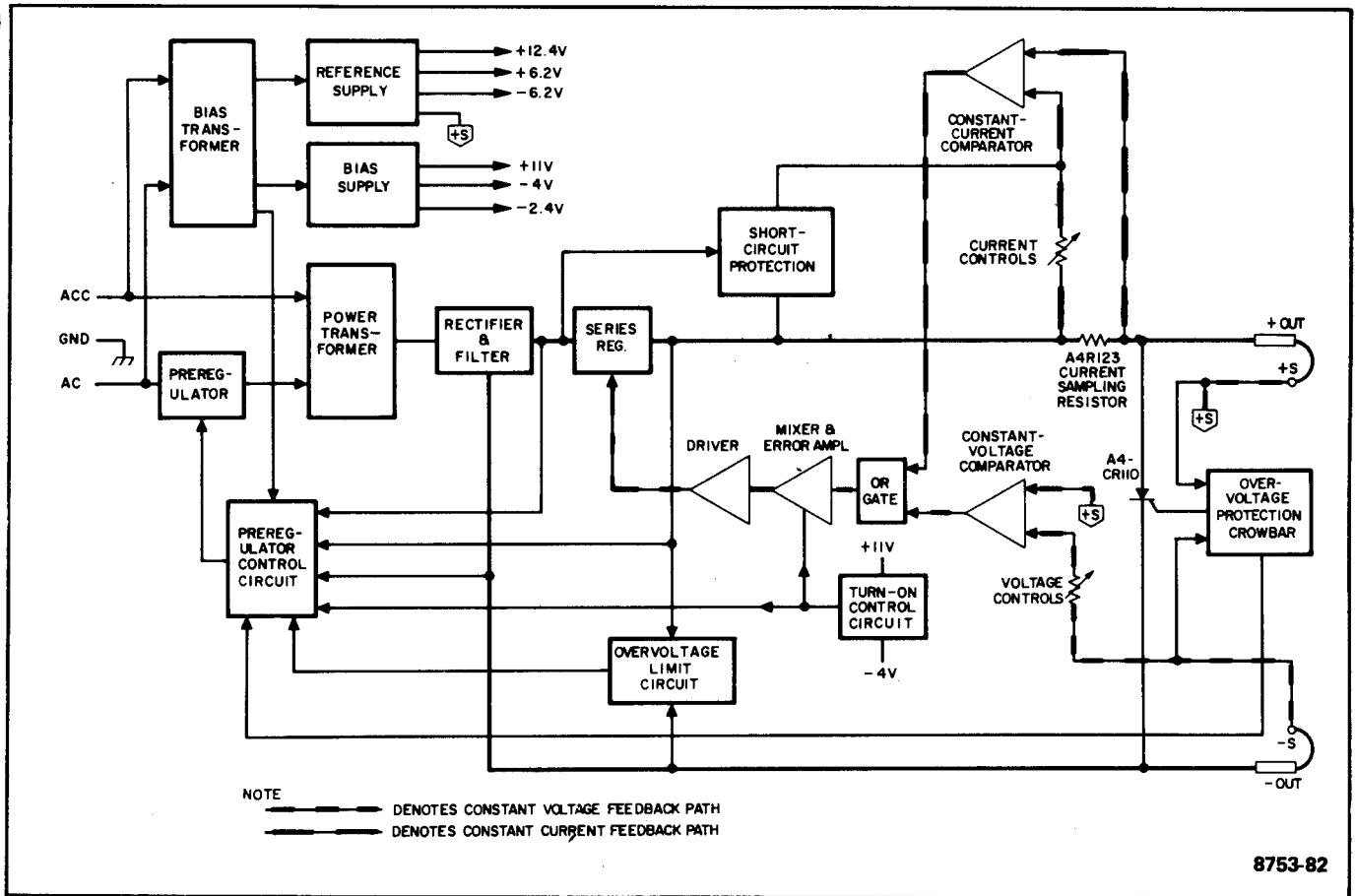

Figure 4-1. Overall Block Diagram

4-1 OVERALL BLOCK DIAGRAM DISCUSSION

4-2 The major circuits of the power supply are shown on the overall block diagram of Figure 4-1. The ac input to the power transformer is preregulated by a triac, which forms a feedback loop in conjunction with the preregulator control circuit. This feedback loop maintains a low and constant voltage drop across the series regulator in order to minimize dissipation in the series regulator transistors.

4-3 To accomplish this, the preregulator control circuit issues a phase-adjusted firing pulse to the triac once during each half cycle of the ac input. The control circuit continuously samples the input line voltage, the dc input to the series regulator, and the voltage across the series regulator. On the basis of these inputs it controls the time at which each firing pulse is generated.

4-4 The output of the triac preregulator is stepped down by the power transformer, full-wave rectified, and filtered. The resulting preregulated dc voltage is applied to the series regulator, which varies its conduction to provide a regulated voltage or current at the output terminals.

4-5 The series regulator is part of another feedback loop which consists of the error and driver amplifiers, the constant-voltage comparator, and the constant-current comparator. The series regulator feedback loop makes rapid, low magnitude adjustments to the output while the preregulator feedback loop handles large, relatively slow regulation demands.

4-6 The feedback signals that control the conduction of the series regulator originate in the constant-voltage or constant-current comparator. During constant-voltage operation the constant-voltage comparator compares the

output voltage of the supply with the drop across the VOLTAGE controls. If these voltages are not equal, the comparator produces an error signal that is amplified and fed back to the series regulator with the correct phase and amplitude to make them equal. In this manner, the constant-voltage comparator holds the output voltage at the level established by the VOLTAGE controls.

4-7 During constant-current operation, the constant-current comparator detects any difference between the voltage drop developed by load current flowing through the current sampling resistor and the voltage across the CURRENT controls. If the two inputs to the comparator are momentarily unequal, an error signal is generated that alters the conduction of the series regulator by the amount necessary to reduce the error voltage at the comparator's input to zero. Hence, the IR drop across the current sampling resistor, and therefore the output current, is held at a constant value.

4-8 Since the constant-voltage comparator causes the output impedance to be low and allows the output current to change whenever the load resistance changes, while the constant-current comparator causes the output impedance to be high and allows the output voltage to change in response to a load resistance change, it is obvious that the two comparison amplifiers cannot control the output simultaneously. For any given value of load resistance, the power supply must act either as a constant-voltage source or as a constant-current source. To enable one comparator or the other to take control, the outputs of both comparators are connected to the input of the mixer amplifier through an OR gate.

4-9 Figure 4-2 shows the output characteristic of a constant-voltage/constant-current power supply. With no load connected, the output current ( $I_{OUT}$ ) is zero and the output voltage ( $E_{OUT}$ ) equals the front panel voltage control setting ( $E_S$ ). When a load resistance is connected to the output terminals of the supply, the output current increases while the output voltage remains constant. Point D thus represents a typical constant-voltage operating point. Further decreases in load resistance are accompanied by further increases in  $I_{OUT}$  with no change in the output voltage until the output current reaches  $I_S$ , a value equal to the front panel current control setting. At this point the supply automatically changes its mode of operation and becomes a constant-current source. Still further decreases in the value of load resistance are accompanied by a drop in the supply's output voltage with no accompanying change in its output current. With a short circuit across the load terminals,  $I_{OUT} = I_S$  and  $E_{OUT} = 0$ .

4-10 The "crossover" value of load resistance can be defined as  $R_C = E_S / I_S$ . Adjustment of the front Panel

voltage and current controls permit this "crossover" resistance  $R_C$  to be set to any desired value from 0 to  $\infty$ . If  $R_L$  is greater than  $R_C$ , the supply is in constant-voltage operation. If  $R_L$  is less than  $R_C$ , the supply is in constant-current operation.

4-11 The short-circuit protection circuit (see Figure 4-1) protects the series regulator if the supply's output is shorted while its controls are set to a high output voltage and current. The protection circuit monitors the voltage drop across the series regulator. If this voltage rises above a preset level, the protection circuit limits the current through the series regulator until the preregulator can reduce the voltage across the series regulator. Once this voltage returns to normal, the short-circuit protection circuit is turned off and has no further effect on the operation of the supply.

4-12 The overvoltage protection crowbar monitors the output of the supply and fires an SCR which short circuits the supply if its output exceeds a preset threshold. The crowbar also sends a turn-down signal to the preregulator control circuit.

4-13 The overvoltage limit circuit protects the main rectifier diodes and filter capacitors from damage if the series regulator transistors short or the voltage programming control opens. The circuit monitors the output voltage of the supply and sends a turn-down signal to the preregulator control circuit if the voltage exceeds approximately 120% of its rated maximum.

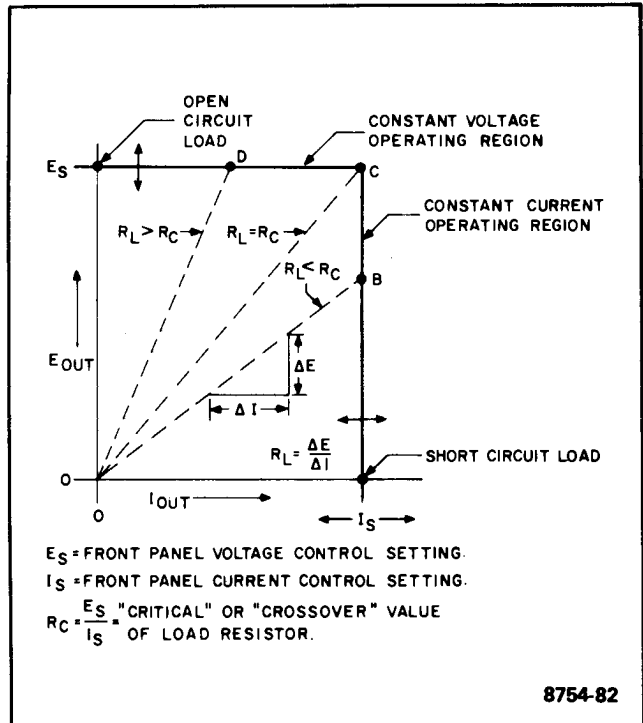

Figure 4-2. Operating Locus of a CV/CC Power Supply

4-14 The turn-on control circuit is a long-time-constant network that gives the supply a gradual turn-on characteristic. The slow turn-on feature protects the preregulator triac and the series regulator from damage that might occur when ac power is first applied to the unit. At turn-on, the control circuit sends inhibiting voltages to the preregulator control and the series regulator (via the error and driver amplifiers). After a brief delay, the inhibiting voltages are removed and the circuit has no further control over the operation of the supply.

4-15 The reference supply provides stable reference voltages used by the constant-voltage and current-comparators. Less critical operating voltages are obtained from an unregulated bias supply.

### 4-16 DETAILED CIRCUIT ANALYSIS

(Figure FO-1)

### 4-17 Preregulator Control Circuit

4-18 The preregulator minimizes the power dissipated by the series regulating transistors during input line voltage or dc output voltage variations. Preregulation is accomplished by a phase control circuit using triac A2CR1 as the switching element.

4-19 The triac is a bi-directional device; it can conduct current in either direction. Hence, it fires whenever it receives a gating pulse regardless of the polarity of the ac voltage applied to it. The triac is fired once during each half-cycle of the ac input (see Figure 4-3). When the triac is fired early in the half-cycle, the ac level applied to the power transformer is relatively high. When the triac is fired later in the half-cycle, the ac level is relatively low.

4-20 Normally the ac input must be above a certain minimum potential before a triac will conduct. However, A2C1 and C2 and A2R1 and R2 provide a holding current that allows the triac to conduct at any time during the ac input cycle. RFI choke A2L1 slows down the turn-on of the triac in order to minimize spikes at the output of the supply. The components of the A2RFI Filter Assembly are all mounted inside a shielded box to minimize radiated and reflected RFI. Further RFI suppression is provided by line bypass capacitors.

4-21 The preregulator control circuit samples the input line voltage, the dc input to the series regulator, and the voltage across the series regulator transistors. It generates firing pulses that fire the triac and adjusts the phase of these pulses so that the dc voltage across the series regulator remains constant.

4-22 The inputs to the control circuit are algebraically summed across capacitor C70. All inputs affect the time

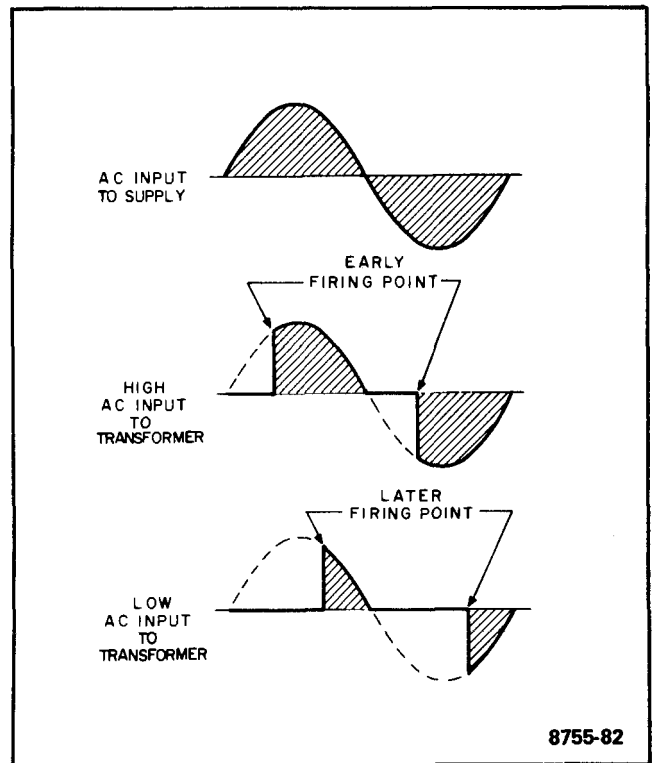

Figure 4-3. Triac Phase Control of AC Input Amplitude

required to charge C70. The input line voltage is rectified by CR81, CR82, CR83, and CR84, attenuated by voltage divider R83, and R86, and applied to the summing point at the collector of Q71 (TP80) via capacitor C70. Capacitor C73 is used for smoothing purposes.

4-23 Transistor Q71, connected in a common base configuration, provides a charging current to the summing capacitor which varies with the input signals applied to its emitter. Resistor R78, connected between the negative output line and the emitter of Q71, furnishes a signal proportional to the output voltage. Resistors R75 and R76 sample the voltage across, and the current through, the series regulator. Resistors R70 and R80 are the source of a constant offset current to the summing point, which ensures that the triac will fire at low output voltages. Capacitor C72 and resistor R82 stabilize the entire preregulator feedback loop.

4-24 The summation of these input signals results in a voltage waveform at TP80 similar to that shown in waveform (A) of Figure 4-4. When the linear ramp portion of the waveform reaches a certain negative threshold, diodes CR74 and CR75 become forward biased. These diodes couple a negative voltage to the base of transistor Q72. Transistors Q72 and Q73 form a bistable circuit similar to a Schmitt trigger. Prior to firing time, Q72 is conducting due to the positive bias supplied to its base through R84. Transistor Q73 is cut off because its base is driven negative by the collector of Q72.

4-25 When the negative threshold voltage is reached, transistor Q72 is turned off and Q73 is turned on. The conduction of Q73 allows capacitor C71 to discharge rapidly through pulse transformer T70, generating a firing pulse across the secondary of T70. Diode CR88 blocks any positive overshoot.

4-26 The control circuit is reset once every 8.33 milliseconds when the rectified ac voltage at the junction of CR77, CR78, and CR79 (TP82) forward biases diode CR78. Summing capacitor C70 is then allowed to discharge through CR78, Diodes CR74 and CR75 become reverse biased at reset, allowing Q72 to turn on. Consequently, Q73 is turned off and capacitor C71 charges up through R79 at a comparatively slow rate until the collector voltage of Q73 reaches approximately +11 volts.

**4-27 Overvoltage Limit Circuit**  
(Figure FO-1)

4-28 Under normal circumstances, Q70 in the overvoltage limit circuit is biased off by the equal voltages on its base and emitter. Diodes CR70 and CR71 are forward biased by a small current through R71 to develop Q70's base voltage. R72, connected between Q70's base and the supply's negative output, shunts an amount of current away from the diodes that is proportional to the supply's output voltage. When the output voltage reaches approximately 120% of its rated maximum, the diode current falls to zero, biasing Q70 on. When Q70 conducts, it disables the preregulator by holding CR74 and CR75 reverse biased to prevent Q72 and Q73 from generating triac firing pulses.

**4-29 Series Regulator and Driver**  
(Figure FO-1)

4-30 Depending on the model, the series regulator is composed of four, six, or eight transistors connected in parallel. These transistors serve as the series element that provides precise and rapid control of the output. The series transistors are controlled by driver A4Q102. Thermal switch A4TS101 turns off the series regulator transistors by opening if the heatsink temperature exceeds approximately 230°F. This feature protects critical components from the excessive temperatures that could occur if cooling fan A4B1 failed. Diode CR50 provides a discharge path for the output capacitors when the supply is rapidly down-programmed. Resistor R57 limits the discharge current through the diode and through error amplifier A4Q101. Diode A4CR105 is connected across the regulator circuit to protect the series elements from reverse voltages that could develop if one supply is turned on or off before the other during parallel operation.

**4-31 Short-Circuit Protection**  
(Figure FO-1)

4-32 The short-circuit protection circuit protects the

series regulator against damage due to a simultaneous full-voltage full-current condition as might occur if the output were shorted while the controls were set to deliver a high output voltage and current. If this occurs, the increased voltage across the series regulator turns Q20 on and shuts off the preregulator. The conduction of Q20 puts R26 in parallel with the current controls to limit the output current to less than 10% of the supply's rating. The preregulator shuts off within 10 milliseconds after the short circuit is imposed. Then the input capacitor begins to discharge through the series regulator and the voltage across the regulator decreases until Q20 turns off. The discharge time (typically 1/2 to 4 seconds) depends on the voltage and current ratings of the supply, the size of the main filter capacitor, and the control settings. Once this recovery time has elapsed, the output current returns to the level set by the current controls, and the preregulator returns the voltage across the series regulator to its normal 3.5-volt level.

**4-33 Constant-Voltage Comparator**  
(Figure FO-1)

4-34 The constant-voltage comparator consists of programming resistors A5R121 and A5R122, differential amplifier Z1, and associated components. An integrated circuit is used for the differential amplifier to minimize

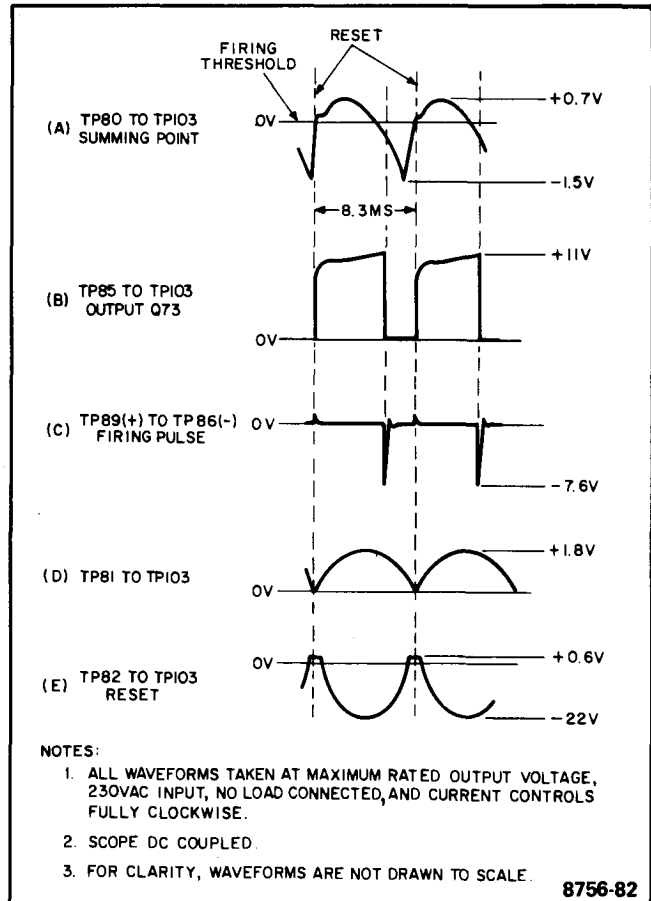

Figure 4-4. Preregulator Control Circuit Waveforms



voltage differentials due to mismatched transistors or temperature differences.

4-35 The constant-voltage comparator compares the voltage drop across the VOLTAGE controls with the supply's output voltage. If a difference exists, it produces an error voltage proportional to this difference. This error signal alters the conduction of the series regulator, which changes the output voltage until it is equal to the voltage drop across the VOLTAGE controls. Hence, through feedback action, the difference between the two inputs to Z1 is held at zero volts.

4-36 One input of the differential amplifier (pin 10) is connected to the output voltage sensing terminal of the supply (+S) through impedance equalizing resistor R23. Resistors R1 and optional resistor R110 zero bias the input. If the supply is equipped with Option 020 or 040, resistor R114 and potentiometer R113 provide a variable input bias that allows the output voltage to be easily adjusted to exactly zero volts when the supply is programmed for zero output. The other input of the differential amplifier (pin 1) is connected to the summing point (terminal A2) at the junction of the programming resistors and current pullout resistors R3, R4, and R5. Instantaneous changes in the output voltage or changes in the voltage at the summing point due to changes in the VOLTAGE control setting produce a difference voltage between the two inputs of the differential amplifier. This difference voltage is amplified and appears at the output of the differential amplifier (pin 12) as an error voltage which ultimately varies the conduction of the series regulator.

4-37 Resistor R6, in series with the summing point input to the differential amplifier, limits the current flowing into the differential amplifier during rapid voltage turn-down. Diode CR7 prevents excessive current drain from the +6.2 volt reference supply during rapid down-programming. Diodes CR5 and CR6 prevent excessive voltage excursions from overdriving the differential amplifier.

4-38 During constant-voltage operation, the programming current flowing through the programming resistors (VOLTAGE controls) is constant because the summing point is held constant at zero volts by feedback action and virtually all of the reference supply current flowing through pull-out resistors R3, R4, and R5 flows through VOLTAGE controls A5R121 and A5R122. Linear constant-voltage programming is thus assured. Resistor R3 serves as a trimming adjustment for the programming current flowing through A5R121 and A5R122. If the supply is equipped with Option 020 or 040, resistor R111 and potentiometer R112 allow the programming current to be adjusted over a narrow range around its nominal value. In practice, this adjustment sets the power supply output to exactly the

maximum rated voltage when programmed to that level.

4-39 Main output capacitor A3C3, connected across the output terminals of the supply, stabilizes the series regulator feedback loop and helps supply high-current pulses of short duration during constant-voltage operation. An additional output capacitor (C19) is connected directly across the output bus bars to maintain a low ac output impedance by compensating for the inductive reactance of the main output capacitor at high frequencies. C19 also helps to minimize output spikes.

#### 4-40 Constant-Current Comparator (Figure FO-1)

4-41 The constant-current comparator is similar in appearance and operation to the constant voltage comparator. It consists of programming resistors A5R123 and A5R124, differential amplifier Z1, and associated components.

4-42 The constant-current comparator circuit compares the voltage drop across the CURRENT controls with the voltage drop across current sampling resistor A4R123. If a difference exists, the differential amplifier produces an error signal proportional to this difference. The remaining components in the feedback loop (amplifiers and the series regulator) maintain the drop across the current sampling resistor, and hence the output current, at a constant value.

4-43 One input of the differential amplifier (pin 7) is connected to the output bus through impedance equalizing resistor R20 and is zero-biased by R21 and optional resistor R117. Its other input (pin 4) is connected to the summing point (terminal A6) at the junction of programming resistors A5R123 and A5R124 and current pullout resistors R30 and R31. Instantaneous changes in the output current due to load changes or changes in the voltage at the summing point due to changes in the CURRENT control setting produce a difference voltage between the two inputs of the differential amplifier. This difference voltage is amplified and appears at the output of the differential amplifier (pin 6) as an error voltage which ultimately varies the conduction of the series regulator.

4-44 Resistor R30 serves as a trimming adjustment for the programming current flowing through A5R123 and A5R124. If the supply is equipped with Option 021 or 040, resistor R115 and potentiometer R116 allow the programming current to be adjusted over a narrow range around its nominal value, and resistor R118 and potentiometer R119 provide a variable input bias to allow the output current to be easily adjusted to exactly zero when the supply is programmed for zero output. Diode CR21 limits excessive voltage excursions at the summing-point input to the differential amplifier.

#### 4-45 Voltage Clamp Circuit

(Figure FO-1)

4-46 The voltage clamp circuit keeps the constant-voltage programming current relatively constant when the power supply is operating in the constant-current mode. This is accomplished by clamping terminal A2, the voltage summing point, to a fixed bias voltage. During constant-current operation the constant-voltage programming resistors are a shunt load across the output terminals of the supply. When the output voltage changes, the current through these resistors also tends to change. Since this programming current flows through the current sampling resistor, it is erroneously interpreted as a load change by the current comparator circuit. The voltage clamp eliminates this undesirable effect by maintaining the programming current at a constant level.

4-47 The voltage divider consisting of Z2A, Z2B, and VR1 back biases CR2 and Q1 during constant-voltage operation. When the power supply goes into constant-current operation, CR2 becomes forward biased by the voltage at pin 12 of Z1. This results in the conduction of Q1 and the clamping of the summing point at a potential only slightly more negative than the normal constant-voltage potential. Clamping this voltage at approximately the same potential that exists in constant-voltage operation results in a constant voltage across, and consequently a constant current through, current pullout resistors R3, R4, and R5.

#### 4-48 Mixer and Error Amplifiers

(Figure FO-1)

4-49 The mixer and error amplifiers amplify the error signal received from the constant-voltage or constant-current input circuit to a level sufficient to drive the series regulator transistors. Mixer amplifier Q41 receives the error voltage input from either the constant-voltage or constant-current comparator via the OR-gate diode (CR1 or CR2) that is conducting at the time. Diode CR1 is forward biased and CR20 reverse biased during constant-voltage operation. The reverse is true during constant-current operation.

4-50 Transistor Q40 provides a constant current to the collector of Q41 and also generates a negative-going turn-off signal for the series regulator when the unit is first turned off. Feedback network C41, R47, and R53 shapes the high frequency rolloff in the loop gain response in order to stabilize the series regulator feedback loop.

4-51 Error amplifiers Q42 and A4Q101 serve as the pre-driver elements for the series regulator. A4Q101 also provides a discharge path for the output capacitors in order to allow faster down-programming and conducts a bleed current for the series regulator to keep it in its active region when the supply is set for zero output current. Diode CR44 prevents

A4Q101's base from going more negative than  $-3$  volts in order to limit the bleed current through R57 and protect A4Q101 from damage if a voltage higher than the programmed output voltage is applied across the output terminals.

#### 4-52 Overvoltage Protection Crowbar

4-53 The overvoltage protection crowbar circuit protects sensitive loads against the application of an excessively high voltage, as might result from a series regulator transistor failure. It accomplishes this by immediately shorting the output of the supply as soon as a preset threshold voltage is exceeded. Until silicon controlled rectifier A4CR110 has been triggered, it acts as an open circuit and has no effect on the output voltage. Transistors Q91 and Q92 detect an overvoltage condition and trigger the SCR to fire. When the SCR fires, it shorts the supply's output.

4-54 During normal operation, Q92 is biased on by current through R99, Q91 is kept turned off by Q92, and CR91 is reverse biased by the voltage divider formed by resistors R90, R95, and A5R125. Zener diode VR90 provides a stable reference voltage with which the  $-S$  potential is compared. Potentiometer A5R125 (OVER-VOLTAGE ADJUST) establishes the output voltage at which CR91 becomes forward biased and turns Q92 off. When Q92 turns off, Q91 begins to conduct, sending a positive-going trigger pulse to A4CR110 and causing it to create a near short circuit across the output. When A4CR110 fires, overvoltage lamp A5DS2 turns on, completing a path for a  $+11V$  unregulated holding current through A5DS2. (R92 supplies the holding current if the lamp should open.) This current holds A4CR110 on even after the output voltage has fallen. A4CR110 remains in conduction until the supply is turned off. A4R106 protects A4CR108 and A4CR110 from the large surge current that occurs when A4CR110 is first fired. CR93 damps out negative overshoot in the trigger pulse.

4-55 The firing of A4CR110 biases Q90 into conduction. This places approximately  $+11$  volts on the cathode of CR74 in the preregulator control circuit to reverse bias CR74 and CR75. By preventing transistor Q72 from turning off, this prevents the generation of any trigger pulses and turns off the preregulator.

4-56 The crowbar circuit creates an extra current path during normal operation of the supply, thus changing the current that flows through the sampling resistor. Diode CR92 keeps this extra current at a fixed level for which compensation can then be made in the constant-current comparator circuit.

4-57 A slaving arrangement for the crowbar circuits in more than one supply is made possible by an extra

secondary winding (terminals 5 and 6) on T90. This winding is connected to terminals on the rear barrier strip marked  $\pm$  EXT. CROWBAR TRIGGER. When two or three units have these windings connected in parallel, all of their crowbars are activated when any one of the crowbars is tripped. To reset the crowbars in this arrangement, all of the units must be turned off and then on. Polarity must be observed when connecting units in this fashion.

#### 4-58 Turn-On Control Circuit (Figure FO-1)

4-59 The turn-on control circuit is a long-time-constant network which protects the triac and the series regulator from possible damage during turn-on. When the supply is first turned on, C35 applies a positive voltage to the anodes of CR35 and CR36. Diode CR35 couples this voltage to the cathode of CR74 in the preregulator control circuit to ensure that it is initially reverse biased. After C35 becomes sufficiently charged, CR35 becomes reverse biased and the preregulator control circuit is permitted to fire the triac.

4-60 Diode CR36 performs a similar function for the series regulator. This diode initially couples a positive voltage to Q41, which inverts it and applies it to the series regulator. This negative voltage keeps the regulator cut off until C35 charges up. Diode CR37 provides a discharge path for C35 when the supply is turned off.

#### 4-61 Reference Regulator (Figure FO-1)

4-62 The reference circuit is a feedback power supply similar to the main supply. It provides stable reference voltages used throughout the unit. All the regulated reference voltages are derived from dc obtained from full-wave rectifier CR61 and CR62 and filter capacitor C61. Zener diodes VR60 and VR61 establish well regulated potentials of +6.2V and -6.2V with respect to common point +S, while the regulator circuit establishes a well regulated potential of +12.4 volts. Resistor R63 establishes an optimum bias current through the zener diodes.

4-63 The regulating circuit consists of series regulating transistor Q60, driver Q61, and differential amplifier Q62 and Q63. The voltage across zener diodes VR60 and VR61 is compared to the voltage across resistor ZZJ, and any difference is amplified by Q62 and Q63. The error voltage thus appearing at the collector of Q62 is amplified by driver stage Q61 and applied to series regulator Q60 in the correct phase and amplitude to maintain the +12.4 volt output at a constant level.

4-64 Diode CR60, connected from voltage divider R66 and R67 to the base of Q61, serves as a turn-on circuit for series regulator transistor Q60. When the supply is first turned on, CR60 biases driver Q61 on, thus turning on the

series regulator. When the reference supply reaches normal output, the base voltage of Q61 is sufficient to reverse bias CR60, thus effectively removing it from the circuit. Capacitor C60, connected across the output of the reference supply, removes spikes and stabilizes the reference regulator loop.

4-65 A separate winding on transformer A3T2, diodes CR53 and CR54, and filter capacitor C44 provide an unregulated +11V output. Additional lightly regulated reference voltages of -2.4 volts and -4 volts are provided by diodes CR45 through CR49. Resistor R41 biases the diodes. Diode CR43 prevents reverse current flow from damaging the main supply series regulator transistor(s). Diode CR7, shown on the schematic near current pullout resistors R3, R4, and R5, protects the zener diodes in the reference circuit by providing a path for surge currents that occur during rapid down-programming.

#### 4-66 Meter Circuit (Figure FO-1)

4-67 The front panel voltmeter and ammeter provide continuous indications of output voltage and current. Both meter movements can withstand an overload of several times the maximum rated output without damage.

4-68 The ammeter, together with its series resistors R101 and R105, is connected across current sampling resistor A4R123. As mentioned previously, the voltage drop across A4R123 varies in proportion to the output current. Potentiometer R101 permits calibration of the ammeter.

4-69 The voltmeter, in series with R103 and R104 and shunted by R102 and R106, is connected directly across the output terminals of the supply. Potentiometer R106 permits calibration of the voltmeter.

#### 4-70 Additional Protection Features (Figure FO-1)

4-71 The supply contains several special purpose components that protect it in the event of unusual circumstances. One of these components is diode A4CR106 (and A4CR107). Connected across the output terminals of the supply, it prevents internal damage from reverse voltages that might be applied across the supply. This could occur, for example, during Auto-Series operation if one supply were turned on or off before the other.

4-72 Resistors R108 and R109 limit the output of the supply if the jumpers between the output buses and the sensing terminals (+S and -S) are inadvertently removed.

4-73 Diode A4CR105, previously mentioned in the series regulator description, protects the regulating transistor from reverse voltages.



## SECTION V MAINTENANCE

### 5-1 INTRODUCTION

5-2 Upon receipt of the power supply, the performance test (paragraph 5-5) should be made. This test is suitable for incoming inspection. If a fault is detected in the power supply while making the performance test or during normal operation, proceed to the troubleshooting procedures (paragraph 5-49). After troubleshooting and repair

(paragraph 5-69) perform any necessary adjustments and calibrations (paragraph 5-71). Before returning the power supply to normal operation, repeat the applicable portions of the performance test to ensure that the fault has been properly corrected and that no other faults exist. Before performing any maintenance checks, turn on the power supply and allow a half-hour warm-up.

Table 5-1. Test Equipment Required

TYPE	REQUIRED CHARACTERISTICS	USE	RECOMMENDED MODEL
Digital Voltmeter	Sensitivity: 100 $\mu$ V full scale (min.) Input Impedance: 10M $\Omega$ (min.)	Measure dc voltages; calibration procedures.	HP 3450B
Oscilloscope	Sensitivity and bandwidth: 100 $\mu$ V/cm and 400kHz for all measurements except noise spike; 5mV sensitivity and 20MHz bandwidth for noise spike measurement.	Measure ripple; display transient recovery waveform; measure noise spikes.	HP 180C with 1821A time base and 1806A vertical plug-in; 1803A plug-in for spike measurement.
Variable Voltage Transformer	Range: 208-254 volts. Output current: 200% (min.) of supply input current listed in para. 2-16.	Vary ac input for line regulation measurement.	---
Digital or Analog Multimeter		Measure ac and dc voltages, resistance.	HP 3490A or HP 427A
Repetitive Load Switch	Switching rate: 60-400Hz. Rise time: 2 $\mu$ sec.	Measure transient recovery time.	See Figure 5-4.
Resistive Load	Values: see Figures 5-1, 5-4, and 5-7.	Power supply load resistor.	---
Current Sampling Resistor	Value: See Figure 5-7.	Measure output current; calibrate ammeter.	---
Terminating Resistors	Value: 50 ohms, 1/2 watt, $\pm$ 5% non-inductive. (Four required.)	Noise spike measurement.	---
Blocking Capacitors	Value: 0.01 $\mu$ F, 100Vdc. (Two required.)	Noise spike measurement.	---
Isolation Transformer	1:1 Ratio	Safety during preregulation troubleshooting.	---

**5-3 TEST EQUIPMENT REQUIRED**

5-4 Table 5-1 lists the test equipment required to perform the procedures described in this section.

**5-5 PERFORMANCE TEST**

5-6 The following test can be used as an incoming inspection check. Appropriate portions of the test can be repeated either to check the operation of the instrument after repairs or for periodic maintenance tests. The tests are performed using a 230Vac 60Hz single-phase input power source. If the correct result is not obtained for a particular check, do not adjust any internal controls; instead proceed to troubleshooting (paragraph 5-49).

**5-7 CONSTANT-VOLTAGE TESTS**  
(Figure 2-1, 5-1)

5-8 Connect all of the measuring devices used in the constant voltage performance tests directly to the power supply sensing terminals ( $\pm S$ ). For best accuracy, the sensing terminals must be used rather than the output terminals, since the measuring instruments must be connected to the same pair of terminals to which the feedback amplifier within the power supply is connected. This is particularly important when measuring the regulation, transient response, or ripple of the power supply. Note that the measuring instruments should not be connected across the load. A measurement made across the load includes the impedance of the leads to the load and such lead lengths can easily have an impedance several orders of magnitude greater than the supply impedance (typically less than 1 milliohm at dc), thus invalidating the measurement.

5-9 To avoid mutual coupling effects, connect each monitoring device to the sensing terminals by a separate pair of leads. Use twisted pairs or shielded two-wire cables to avoid pickup on the measuring leads. Connect the load resistor across the output terminals as close to the supply as possible. When measuring the constant-voltage performance specifications set the current controls well above (at least 10% above) the maximum output current the supply will draw, since the onset of constant-current operation will cause a drop in output voltage, increased ripple, and other performance changes not properly ascribed to the constant-voltage operation of the supply.

**5-10 Voltage Output and Voltmeter Accuracy.** To check that the supply will furnish its rated output voltage, proceed as follows:

- a. Connect load resistor ( $R_L$ ) indicated in Figure 5-1 across output terminals of supply.
- b. Connect digital voltmeter across +S and -S terminals of supply, observing correct polarity.

- c. Turn CURRENT controls fully clockwise.
- d. Turn on supply and adjust VOLTAGE controls until front panel meter indicates exactly maximum rated output voltage.
- e. Digital voltmeter should indicate:
 

6259B, 6260B	10 $\pm 0.2V_{dc}$
6261B	20 $\pm 0.4V_{dc}$
6268B, 6269B	40 $\pm 0.8V_{dc}$

**5-11 Load Effect (Load Regulation).**

Definition: The change  $\Delta E_{OUT}$  in the static value of dc output voltage resulting from a change in load resistance from open circuit to a value which yields maximum rated output current, or vice versa.

5-12 To check the constant-voltage load effect, proceed as follows:

- a. Connect test setup shown in Figure 5-1.
- b. Turn CURRENT controls fully clockwise.
- c. Turn on supply and adjust VOLTAGE controls until front panel meter indicates exactly maximum rated output current.
- d. Read and record voltage indicated on digital voltmeter.
- e. Disconnect load resistor.
- f. Reading on digital voltmeter should not differ from reading recorded in step (d) by more than:
 

6259B, 6260B	1.2mV
6261B	2.2mV
6268B, 6269B	4.2mV

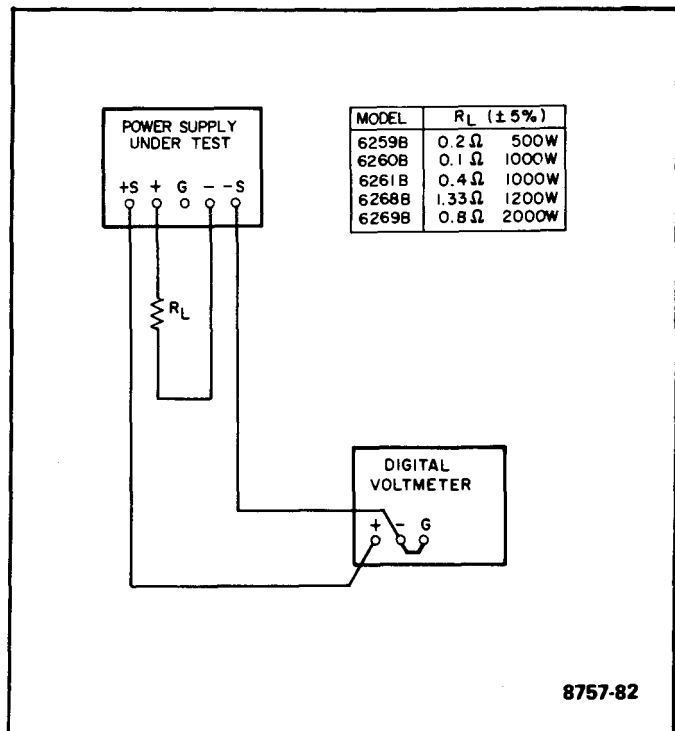

Figure 5-1. Constant-Voltage Load Regulation Test Setup

5-13 Source Effect (Line Regulation).

Definition: The change  $\Delta E_{out}$  in the static value of dc output voltage resulting from a change in ac input voltage over the specified range from low line to high line, or from high line to low line.

5-14 To check the source effect, proceed as follows:

- a. Connect test setup shown in Figure 5-1.
- b. Connect variable autotransformer between input power source and power supply ac input.
- c. Adjust autotransformer for 208Vac input.
- d. Turn CURRENT controls fully clockwise.
- e. Turn on supply and adjust VOLTAGE controls until front panel meter indicates exactly maximum rated output voltage.
- f. Read and record voltage indicated on digital voltmeter.
- g. Adjust variable autotransformer for 254Vac input.
- h. Digital voltmeter reading should not differ from reading recorded in step (f) by more than:

6259B, 6260B	1.2mV
6261B	2.2mV
6268B, 6269B	4.2mV

5-15 Periodic and Random Deviation (PARD) (Ripple and Noise).

Definition: The residual ac voltage superimposed on the dc output of a regulated power supply. Ripple and noise measurements may be made at any input ac line voltage combined with any dc output voltage and load current within the supply's rating.

5-16 The amount of ripple and noise present on the power supply output is measured either in terms of its rms or (preferably) peak-to-peak value. The peak-to-peak measurement is particularly important for applications where noise spikes could be detrimental to sensitive loads such as logic circuitry. The rms measurement is not an ideal representation of the noise since fairly high output noise spikes of short duration can be present in the ripple without appreciably increasing the rms value.

5-17 Ripple Measurement Techniques. Figure 5-2A shows an incorrect method of measuring peak-to-peak ripple. Note that a continuous ground loop exists from the third wire of the input power cord of the supply to the third wire of the input power cord of the oscilloscope via the grounded power supply case, the internal jumper connecting the power supply negative output and sensing terminals, the wire between the negative sensing terminal of the power supply and the vertical input of the scope, and the grounded scope case. Any ground current circulating in this loop as a result of the difference in potential  $E_0$  between the two ground points causes an IR drop which is in series with the scope input. This IR drop, normally having a 60Hz line frequency fundamental,

plus any pickup on the unshielded leads interconnecting the power supply and scope, appears on the face of the CRT. The magnitude of this resulting noise signal can easily be much greater than the true ripple developed between the plus and minus sensing terminals of the power supply and can completely invalidate the measurement.

5-18 The same ground current and pickup problems can exist if an rms voltmeter is substituted for the oscilloscope in Figure 5-2A. However, the oscilloscope display, unlike the true-rms meter reading, tells the observer immediately whether the fundamental period of the signal displayed is 8.3 milliseconds (1/120Hz) or 16.7 milliseconds (1/60Hz). Since the fundamental ripple frequency present on the output of an HP supply is 120Hz (due to full-wave rectification), an oscilloscope display showing a 120Hz fundamental component indicates a "clean" measurement setup, while the presence of a 60Hz fundamental usually means that an improved setup will result in a more accurate (and lower) value of measured ripple.

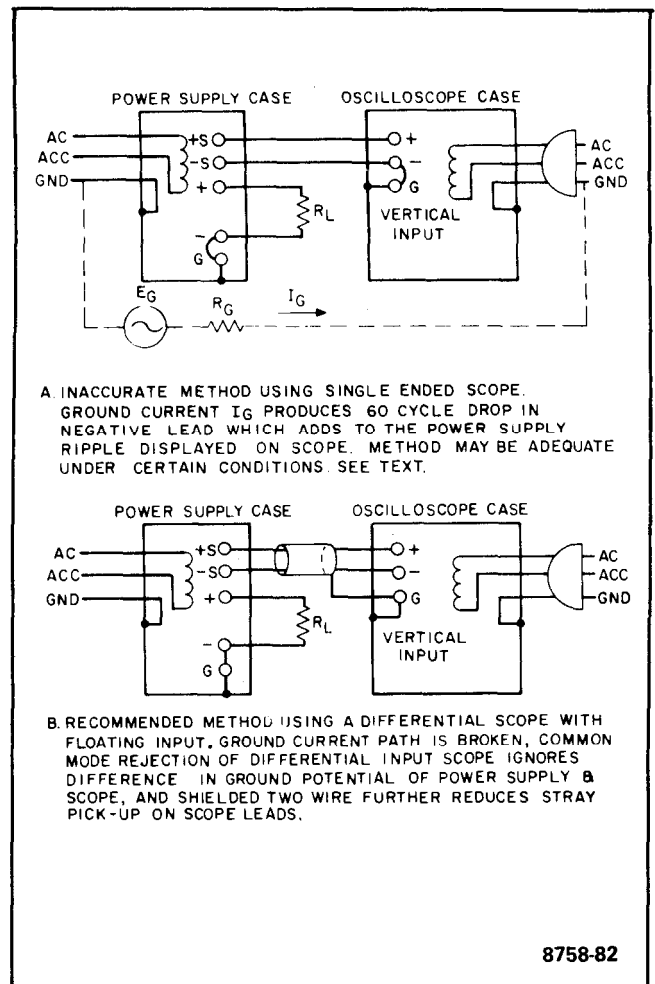

Figure 5-2. Ripple Test setup

5-19 Although the method shown in Figure 5-2A is not recommended for ripple measurements, it may prove satisfactory in some instances provided certain precautions are taken. One method of minimizing the effects of ground current flow ( $I_g$ ) is to ensure that both the supply and the test instrument are plugged into the same ac power bus.

5-20 To minimize pickup, a twisted pair or (preferably) a shielded two-wire cable should be used to connect the sensing terminals of the power supply to the vertical input terminals of the scope. When using a twisted pair, take care that the same wire is connected both to the grounded terminal of the power supply and the grounded input terminal of the oscilloscope. When using shielded two-wire cable, it is essential for the shield to be connected to ground at only one end to prevent any ground current flowing through this shield from inducing a signal in the shielded leads (see Figure 5-2).

5-21 To verify that the oscilloscope is not displaying ripple that is induced in the leads or picked up from the grounds, short the (+) scope lead to the (-) scope lead at the power supply terminals. The ripple value obtained when the leads are shorted should be subtracted from the indicated ripple measurement.

5-22 If the foregoing measures are used, the single-ended scope of Figure 5-2A might be adequate to eliminate extraneous ripple components so that a satisfactory measurement can be obtained. However, in stubborn cases or in measurement situations where it is essential that both the power supply case and the oscilloscope case be connected to ground (if both are rack-mounted, for example), it may be necessary to use a differential scope with floating input as shown in Figure 5-2B. If desired, two single-conductor shielded cables may be substituted in place of the shielded two-wire cable with equal success. Because of its common mode rejection, a differential oscilloscope displays only the difference in signal between its two vertical input terminals, thus ignoring the effects of any common mode signal produced by the difference in the ac potential between the power supply case and scope case. Before using a differential input scope, however, it is imperative that the common mode rejection capability of the scope be verified by shorting together its two input leads at the power supply and observing the trace on the CRT. If this trace is a straight line, then the scope is properly ignoring any common mode signal present. If this trace is not a straight line, then the scope is not rejecting the ground signal and must be realigned in accordance with the manufacturer's instructions so that proper common mode rejection is attained.

5-23 **Ripple Measurement Procedure.** To check the ripple output, proceed as follows:

- a. Connect oscilloscope or rms voltmeter as shown in Figures 5-2A, or 5-2B.
- b. Turn CURRENT controls fully clockwise.
- c. Turn on supply and adjust VOLTAGE controls until front panel meter indicates maximum rated output voltage.
- d. The observed ripple should be less than:
 

6259B, 6260B, 6261B	500 $\mu$ V rms, 5mV p-p
6268B, 6269B	1mV rms, 5mV p-p

5-24 **Noise Spike Measurements.** An instrument of sufficient bandwidth must be used when making a high frequency spike measurement. An oscilloscope with a bandwidth of 20 MHz or more is adequate. Measuring noise with an instrument that has insufficient bandwidth may conceal high frequency spikes that could be detrimental to the load.

5-25 The test setup illustrated in Figure 5-2A is generally not adequate for measuring spikes; a differential oscilloscope is necessary. Furthermore, the measurement technique of Figure 5-2B must be modified as follows if accurate spike measurement is to be achieved:

1. As shown in Figure 5-3, two coax cables must be substituted for the shielded two-wire cable.
2. Impedance matching resistors must be included to eliminate standing waves and cable ringing, and capacitors must be connected to block dc current.
3. The length of the test leads outside the coax is critical and must be kept as short as possible. The blocking capacitor and impedance matching resistor should be connected directly from the inner conductor of the cable to the power supply sensing terminal.
4. Notice that the shields at the power supply end of the two coax cables are not connected to the power supply ground since such a connection would give rise to a ground current path through the coax shield and result in an erroneous measurement.

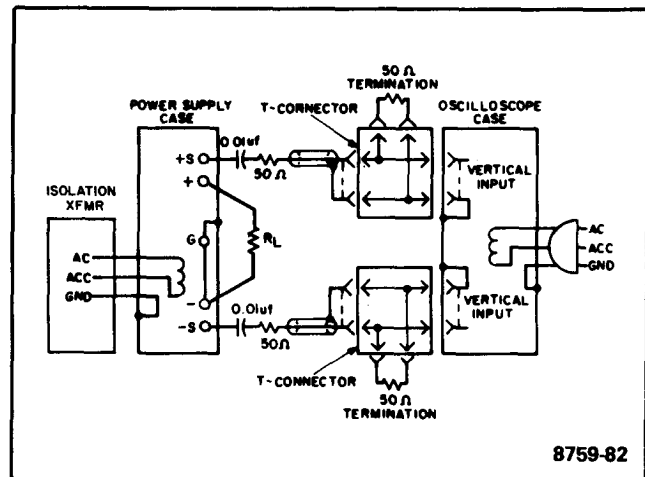

Figure 5-3. Noise Spike Measurement Test Setup



5. Since the impedance matching resistors constitute a 2-to-1 attenuator, the noise spikes observed on the oscilloscope should be less than 2.5mVp-p instead of 5mVp-p.

5-26 The circuit of Figure 5-3 can also be used for the normal measurement of low frequency ripple. Simply remove the four terminating resistors and the blocking capacitors and substitute a higher gain vertical plug-in for the wide-band plug in required for spike measurements. Notice that with these changes, Figure 5-3 becomes a two-cable version of Figure 5-2B.

**5-27 Load Transient Recovery Time (Figure 5-5)**

Definition: The time "X" for output voltage recovery to within "Y" millivolts of the nominal output voltage following a "Z" amp step change in load current, where: "Y" is specified as 10mV; the nominal output voltage is defined as the dc level halfway between the static output voltage before and after the imposed load change; and "Z" is the specified load current change of 5 amps or the full-load current rating of the supply, whichever is less. Load transient recovery time may be measured at any input line voltage combined with voltage and load current within rating.

**5-28 Measurement Techniques.** Care must be taken in switching the load resistance on and off. A hand-operated switch in series with the load is not adequate since the resulting one-shot displays are difficult to observe on most oscilloscopes and the arc energy occurring during switching completely masks the display with a noise burst. Transistor load switching devices are expensive if reasonably rapid load current changes are to be achieved.

5-29 We suggest that a mercury-wetted relay connected in the load switching circuit shown in Figure 5-4 be used for loading and unloading the supply. When this load switch is connected to a 60Hz ac input, the mercury-wetted relay opens and closes 60 times per second. The 25k control adjusts the duty cycle of the load current switching to reduce jitter in the oscilloscope display. This relay may also be used with a 50Hz ac input. The load resistance shown in Figure 5-4 is the minimum resistance that can be used without damaging the mercury-wetted relay contacts.

**5-30 Measurement Procedure.** To check the load

- transient recovery time, proceed as follows:
- Connect test setup shown in Figure 5-4.
  - Turn CURRENT controls fully clockwise.
  - Turn on supply and adjust VOLTAGE controls until front panel ammeter indicates either 5 amps or the full-load current rating of the supply, whichever is less.
  - Close line switch on repetitive load switch setup.
  - Set oscilloscope for internal sync and lock on either the positive or negative load transient spike.

- Set vertical input of oscilloscope for ac coupling so that small dc level changes in power supply output voltage will not cause display to shift.
- Adjust the vertical centering on the scope so that the tail ends of the no-load and full-load waveforms are symmetrically displaced about the horizontal centerline of the oscilloscope. This centerline now represents the nominal output voltage defined in the specification.
- Adjust the horizontal positioning control so that the trace starts at a major graticule division. This point then represents time zero.
- Increase the sweep rate so that a single transient spike can be examined in detail.
- Adjust the sync controls separately for the positive and negative-going transients so that not only the recovery waveshape but also as much as possible of the rise time of the transient is displayed.
- Starting from the major graticule division representing time zero, count to the right 50μsec and vertically 10mV. Recovery should be within these tolerances as illustrated in Figure 5-5.

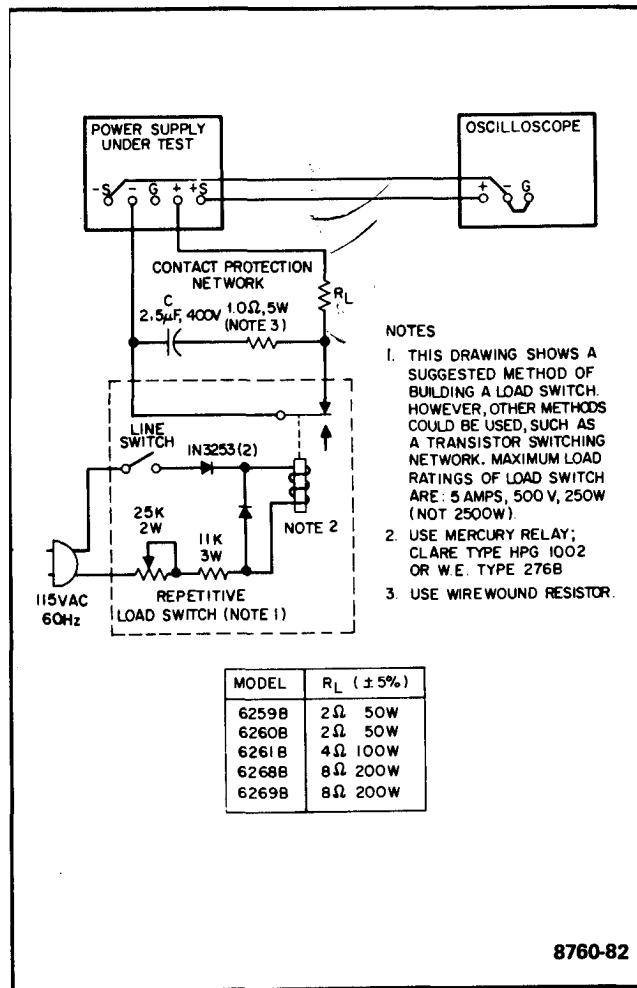

Figure 5-4. Load Transient Recovery Time Test Setup

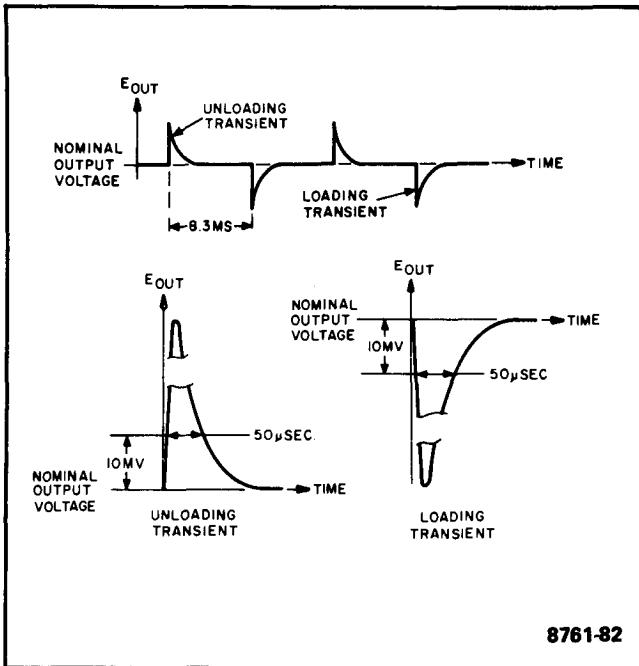

Figure 5-5. Load Transient Recovery Time Waveforms

**5-31 Temperature Coefficient.**

Definition: The change in output voltage per degree Celsius change in the ambient temperature measured while ac line voltage, output voltage setting, and load resistance are all held constant.

5-32 The temperature coefficient of a power supply is measured by placing the power supply in an oven and varying it over any temperature span within its rating. (Most HP power supplies are rated for operation from 0°C to 55°C.) The power supply temperature must be allowed to stabilize for a sufficient time at each measurement temperature.

5-33 The temperature coefficient given in the specifications is the maximum temperature-dependent output voltage change which will result over any one-degree interval. The digital voltmeter used to measure the supply's output voltage change should be placed outside the oven and should have a long-term stability adequate to insure that its drift will not affect the overall measurement accuracy.

5-34 To check the temperature coefficient, proceed as follows:

- a. Connect load resistance and digital voltmeter as illustrated in Figure 5-1.
- b. Turn CURRENT controls fully clockwise.
- c. Turn on supply and adjust front panel VOLTAGE controls until front panel voltmeter indicates maximum rated output voltage (Figure 3-1).
- d. Place power supply in temperature-controlled oven

(digital voltmeter remains outside oven). Set temperature to 30°C and allow 30-minute warm-up.

- e. Record digital voltmeter reading.
- f. Raise temperature to 40°C and allow 30-minute warm-up.
- g. Observe digital voltmeter reading. Difference in voltage reading between steps (e) and (g) should be less than:

6259B, 6260B	12mV
6261B	22mV
6268B, 6269B	42mV

**5-35 Drift (Stability):**

Definition: The change in output voltage for the first eight hours following a 30-minute warm-up period. During the interval of measurement, input line voltage, load resistance, and ambient temperature, are all held constant.

5-36 This measurement is made by monitoring the output of the power supply on a digital voltmeter over the stated measurement interval. A strip chart recorder can be used to provide a permanent record. Place a thermometer near the supply to verify that the ambient temperature remains constant during the period of measurement. The supply should be located away from any source of stray air currents. If possible, place the supply in an oven and hold it at a constant temperature. Take care that the measuring instrument has an eight-hour stability at least an order of magnitude better than the stability specification of the power supply being tested. Typically, a supply will drift less over the eight-hour measurement interval than during the half-hour warm-up.

5-37 To check the output stability, proceed as follows:

- a. Connect load resistance and digital voltmeter as illustrated in Figure 5-1.
- b. Turn CURRENT controls fully clockwise.
- c. Turn on supply and adjust front panel VOLTAGE controls until digital voltmeter indicates maximum rated output voltage (Figure 3-1).
- d. Allow 30-minute warm-up, then record digital voltmeter reading.
- e. After 8 hours, digital voltmeter reading should not differ from the step (d) reading by more than:

6259B, 6260B	5mV
6261B, 6268B	8mV
6269B	14mV

**5-38 CONSTANT-CURRENT TESTS**

5-39 The instruments, methods, and precautions for the proper measurement of constant-current power supply characteristics are for the most part identical to those already described for the measurement of constant-voltage characteristics. There are, however, two main differences:

First, the power supply performance will be checked between short circuit and full load rather than open circuit and full load. Second, a current monitoring resistor is inserted between the output of the power supply and the load.

5-40 For all output current measurements, the current sampling resistor must be connected as a four-terminal device in the same manner as a meter shunt would be. The load current is fed to the extremes of the wire leading to the resistor while the sampling terminals are located as close as possible to the resistance element itself (see Figure 5-6). A current sampling resistor should have low noise, low temperature coefficient (less than 30ppm/°C) and should be used at no more than 5% of its rated power so that its temperature rise will be minimized.

**NOTE**

*In case of difficulty obtaining a low resistance, high current resistor suitable for current sampling, a duplicate of the sampling resistor used in this unit (A4R123, or A4R123A and A4R123B) should be ordered through regular supply channels.*

**5-41 Current Output and Ammeter Accuracy.** To check that the supply will furnish its rated output current, proceed as follows:

- a. Connect test setup shown in Figure 5-7.
- b. Turn VOLTAGE controls fully clockwise.
- c. Turn on supply and adjust CURRENT controls until front panel ammeter indicates maximum rated output current (Figure 3-1).
- d. Digital voltmeter should read 0.5 ±0.01 Vdc.

**5-42 Load Effect (Load Regulation).**

Definition: The change  $\Delta I_{out}$  in the static value of the dc output current resulting from a change in load resistance from short circuit to a value which yields maximum rated output voltage, or vice versa.

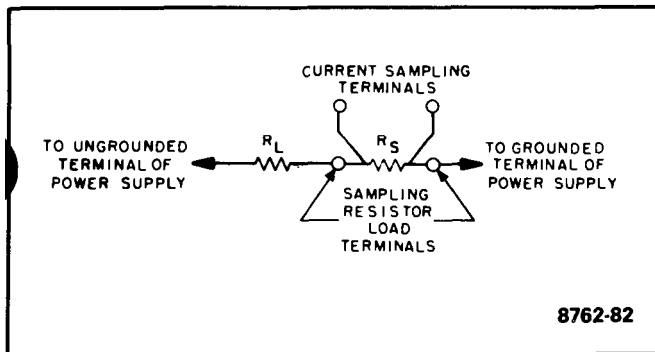

Figure 5-6 Current Resistor Connections

5-43 To check the constant-current load effect proceed as follows:

- a. Connect test setup shown in Figure 5-7.
- b. Turn VOLTAGE controls fully clockwise.
- c. Turn on supply and adjust CURRENT controls until front panel ammeter indicates exactly maximum rated output current (Figure 3-1).
- d. Read and record voltage indicated on digital voltmeter.
- e. Short circuit load resistor ( $R_L$ ).
- f. Digital voltmeter reading should not differ from reading recorded in step(d) by more than:

6259B	110 $\mu$ v
6260B	110 $\mu$ v
6261B	110 $\mu$ v
6268B	134 $\mu$ v
6269B	120 $\mu$ v

**5-44 Source Effect (Line Regulation).**

Definition: The change  $\Delta I_{out}$  in the static value of dc output current resulting from a change in ac input voltage over the specified range from low line to high line or from high line to lowline.

5-45 To check source effect, proceed as follows:

- a. Connect test setup shown in Figure 5-7.
- b. Connect variable autotransformer between input power source and power supply ac input.
- c. Adjust autotransformer for 208Vac input.
- d. Turn VOLTAGE controls fully clockwise.
- e. Turn on supply and adjust CURRENT controls until front panel ammeter reads exactly maximum rated output current (Figure 3-1).
- f. Read and record voltage indicated on digital voltmeter.
- g. Adjust autotransformer for 254Vac input.
- h. Digital voltmeter reading should not differ from reading recorded in step (f) by more than:

6259B	110 $\mu$ v
6260B	110 $\mu$ v
6261B	110 $\mu$ v
6268B	134 $\mu$ v
6269B	120 $\mu$ v

**5-46 PARD (Ripple and Noise).**

Definition: The residual ac current superimposed on the dc output of a regulated power supply. Ripple and noise measurements may be made at any input ac line. voltage combined with any dc output voltage and load current within the supply's rating.

5-47 Most of the instructions pertaining to the ground loop and pickup problems associated with constant-voltage ripple and noise measurement also apply to the measurement of constant-current ripple and noise. Figure 5-8 illustrates the most important precautions to be observed when measuring the ripple and noise of a constant-current

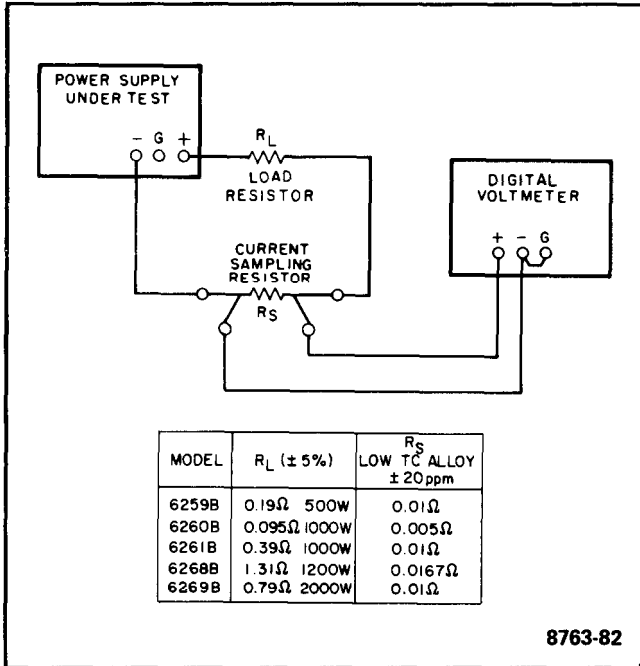

Figure 5-7 Constant-Current Load Regulation test Setup

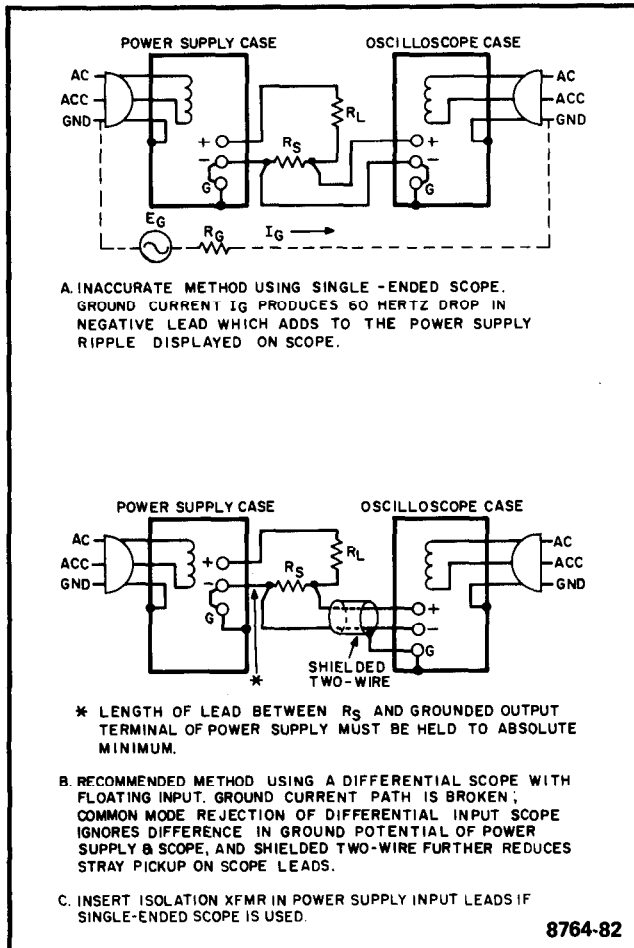

Figure 5-8. Constant-Current Ripple and Noise Test Setup

supply. The presence of a 120Hz waveform on the oscilloscope normally indicates a correct measurement method. A waveshape having 60Hz as its fundamental component usually indicates an incorrect measurement setup.

5-48 To check the ripple and noise, proceed as follows:

a. Connect oscilloscope or rms voltmeter as shown in Figures 5-8A, 5-8B or 5-8C.

b. Rotate VOLTAGE controls fully clockwise.

c. Turn on supply and adjust CURRENT controls until front panel ammeter reads exactly maximum rated output current (Figure 3-1).

d. The observed ripple and noise should be less than:

6259B	250μV rms
6260B	250μV rms
6261B	250μV rms
6268B	334μV rms
6269B	250μV rms

## 5-49 TROUBLESHOOTING

5-50 Before attempting to troubleshoot this instrument, ensure that the fault is with the instrument and not with an associated circuit. The performance test (paragraphs 5-5 through 5-48) enables this to be determined without removing the instrument from the cabinet.

5-51 A good understanding of the principles of operation is a helpful aid in troubleshooting, and it is recommended that the reader review Section IV of the manual before attempting to troubleshoot the unit in detail. Once the principles of operation are understood, refer to the overall troubleshooting procedures in paragraph 5-54 to locate the symptom and probable cause.

5-52 The schematic diagram contains normal voltage readings adjacent to some test points. (Test points are identified by circled numbers.) The measurement conditions are listed in the Schematic Notes. Consult the component location diagrams in Section VI to determine the locations of components and test points (Figures 6-1 through 6-7, FO-1, FO-3).

5-53 If a component is found to be defective, replace it and re-conduct the performance test. When a component is replaced, refer to the repair and replacement (paragraph 5-69) and adjustment and calibration (paragraph 5-71) sections of this manual.

## 5-54 OVERALL TROUBLESHOOTING PROCEDURES

5-55 To locate the cause of trouble, follow steps 1, 2, and 3 in sequence:

(1) Check for obvious troubles such as a defective power cord, an input power failure, or a defective meter.

Next, remove the top and bottom covers and inspect for open connections, charred components, or any other visible defects. If the trouble source cannot be detected by visual inspection, proceed to step (2) (Figs. 6-3, 6-4).

(2) In almost all cases, the trouble can be caused by incorrect dc bias or reference voltages ; thus, it is a good practice to check the voltages in Table 5-2 before proceeding with step (3).

(3) Disconnect the load and examine Table 5-3 for your symptom and its probable cause.

5-56 Table 5-3 contains symptoms and probable causes of many possible troubles. If either high or low output voltage is a symptom, Table 5-4 contains the steps necessary to isolate the trouble to one of the feedback loops and instructions directing the tester to the proper table for further isolation. Because of the interactions between loops, it is necessary to refer to Table 5-4 before proceeding to Tables 5-5, 5-6, or 5-7.

5-57 Tables 5-5, 5-6, and 5-7 contain troubleshooting procedures for the series regulator and preregulator feed-

back loops once the fault has been isolated to one of them. Tables 5-5 and 5-6 contain instructions for driving each stage into conduction or cut-off. By following the steps in these tables, the fault can be isolated to a circuit or a component.

5-58 Table 5-7 contains troubleshooting procedures for the preregulator feedback loop. Troubleshooting is accomplished by comparing waveform illustrations with the waveforms found at various test points and then checking the components most likely to be at fault.

5-59 After troubleshooting the unit, it may be necessary to perform one or more of the calibration procedures given in this section.

**WARNING**

*Some circuits in this power supply are connected directly to the input ac power line. The red-painted case and heatsink of the A2 RFI Assembly are also at ac line potential. Exercise extreme caution when working on energized circuits.*

**Table 5-2 Reference and Bias Voltages**

(Refer to schematic and component location diagrams in Section VI for test point locations)

STEP	METER COMMON	METER POSITIVE	NORMAL VDC	NORMAL RIPPLE (P-P)	PROBABLE CAUSE
1	⊕S	TP63	12.4 ±7%	2.0mV	CR61, CR62, Q60, Q61, Q62, Q63
2	⊕S	TP64	6.2 ±5%	0.5mV	VR60, VR61, R63
3	TP65	⊕S	6.2 ±5%	2.0mV	VR60, VR61, R63
4	⊕S	TP66	11 ±15%	2.0V	CR53, CR54, C44
5	TP67	⊕S	4.0 ±12.5%	0.8V	CR53, CR54, C44, CR45-49
6	TP68	⊕S	2.4 ±12.5%	0.4V	CR53, CR54, C44, CR45-49

**Table 5-3 Overall Troubleshooting**

SYMPTOM	PROBABLE CAUSE
Low or no output voltage (OVERVOLTAGE lamp may be on or off).	a. Front panel meter defective. b. Crowbar not reset or defective. Refer to Table 5-4. c. Series regulator or preregulator feedback loop defective. Refer to Table 5-4.
High output voltage	a. Front panel meter defective. b. Series regulator or preregulator loop defective. If crowbar does not trip, it too is faulty. Refer to Table 5-4. c. Open circuit between sensing terminals (±S) and output terminals (±OUT). Refer to Table 5-4.

Table 5-3. Overall Troubleshooting (Continued)

SYMPTOM	PROBABLE CAUSE
High ripple	a. Ground loops in operating setup. Refer to paragraph 5-17. b. Incorrect reference or bias voltages. Refer to Table 5-2. c. Supply crossing over to constant-current operation under loaded conditions. Check current limit setting or constant-current comparator circuit (Z1 and associated components).
Poor line regulation	a. Improper measurement technique. Refer to paragraph 5-13. b. Incorrect reference or bias voltages. Refer to Table 5-2.
Poor load regulation (Constant-voltage)	a. Improper measurement technique. Refer to paragraph 5-11. b. Incorrect reference or bias voltages. Refer to Table 5-2. c. Supply current limiting. Check constant-current comparator circuit (Z1 and associated components).
Poor load regulation (Constant-current)	a. Incorrect reference or bias voltages. Refer to Table 5-2. b. Supply voltage limiting. Check constant-voltage comparator circuit (Z1 and associated components) and voltage clamp circuit Q1. c. Leaky C19, A3C3. d. CR92 defective.
Oscillates (Constant-current or constant-voltage)	a. Adjustment of R47. Refer to paragraph 5-98. b. Faulty C40, C41, C19, A3C3, R50. c. Open sensing lead (+S).
Instability (Constant-current/constant-voltage)	a. Incorrect reference or bias voltages; CR92 defective. Refer to Table 5-2. b. Noisy voltage or current controls (A5R121, A5R122, or A5R123, A5R124); noisy VR60 or VR61. c. Integrated circuit Z1 defective. d. CR4, CR5, CR6, or CR21 leaky. e. R3, R4, R5, R6, R22, R30, R31, C2 noisy or drifting.
Cannot reach maximum output	Q20 shorted. One or more series regulator transistors (A4Q103 thru A4Q110) open.

Table 5-4. Feedback Loop Isolation

STEP	ACTION	RESPONSE	PROBABLE CAUSE
1	Inspect LINE circuit breaker.	a. Breaker tripped. b. Breaker OK; output voltage high. c. Breaker OK; output voltage low.	NOTE: After each step, reset crowbar by turning supply off then on. a. Check rectifier, filter, and triac for short. Proceed to step 3. b. Proceed to step 2. c. Proceed to step 2.

Table 5-4. Feedback Loop Isolation (Continued)

STEP	ACTION	RESPONSE	PROBABLE CAUSE
2	Inspect OVERVOLTAGE lamp on front panel.	<p>a. On.</p> <p>b. Off; output voltage high.</p> <p>c. Off; output voltage low.</p>	<p>a. Check setting of OVERVOLTAGE ADJUST (A5R125). Check A4CR110 for short. Proceed to step 3.</p> <p>b. Check OVERVOLTAGE ADJUST (A5R125). Check A4CR110 for open. Also check Q91 and Q92. Proceed to step 3.</p> <p>c. Check OVERVOLTAGE ADJUST (A5R125). Check A4CR110 for open. Also check Q20, Q91, and Q92. Proceed to step 3.</p>
3	<p>Isolate fault to series regulator or preregulator by proceeding as follows:</p> <p>(1) Open the gate lead of triac A2CR1 by disconnecting one end of R88 (TP87 or TP88).</p> <p>(2) Observing correct polarity, connect a small dc power supply across input capacitor (C101). A 0-10V, 2A supply is sufficient.</p> <p>(3) Set external supply to ten volts.</p> <p>(4) Vary front panel voltage controls.</p>	<p>a. Output voltage normal (variable from 0 volts to about 9 volts).</p> <p>b. Output voltage high. Varying controls has little or no effect.</p> <p>c. Output voltage low. Varying controls has little or no effect.</p>	<p>a. Check each series regulator transistor (A4Q103 through A4Q106, A4Q108, or A4Q110) for open. Then check preregulator by disconnecting external source and proceeding to Table 5-7.</p> <p>b. High voltage condition in series regulator. Proceed to Table 5-5. Leave external source connected.</p> <p>c. Low voltage condition in series regulator loop. Proceed to Table 5-6. Leave external source connected.</p>

Table 5-5. Series Regulator Troubleshooting, High Output Voltage

STEP	ACTION	RESPONSE	PROBABLE CAUSE
	Make these tests with external source connected as described in step 3 of Table 5-4. Leave the coarse voltage control set to the center of its range while making these tests.		
1	Check turn-off of series regulator transistors A4Q103 through A4Q106, A4Q108, or A4Q110 by momentarily shorting base (TP101) to emitter (TP103).	<p>a. Output voltage remains high.</p> <p>b. Output voltage decreases.</p>	<p>a. One or more of A4Q103 through A4Q106, A4Q108, or A4Q110 shorted or A4CR105 shorted. Check A4R150–A4R165 (as applicable).</p> <p>b. Proceed to step 2.</p>
2	Check turn-off of driver A4Q102 by momentarily shorting base (TP100) to emitter (TP101).	<p>a. Output voltage remains high.</p> <p>b. Output voltage decreases.</p>	<p>a. A4Q102 shorted.</p> <p>b. Proceed to step 3.</p>
3	Check turn-on of error amplifier A4Q101 by momentarily shorting Q42 emitter (TP46) to collector (TP68).	<p>a. Output voltage high.</p> <p>b. Output voltage decreases.</p>	<p>a. A4Q101 open.</p> <p>b. Proceed to step 4.</p>

Table 5-5. Series Regulator Troubleshooting. High Output Voltage (Continued)

STEP	ACTION	RESPONSE	PROBABLE CAUSE
4	Check turn-on of error amplifier Q42 by momentarily shorting base (TP44) to collector (TP68).	a. Output voltage remains high. b. Output voltage decreases.	a. Q42 open. b. Proceed to step 5.
5	Check turn-off of mixer amplifier Q41 by momentarily shorting base (TP40) to emitter (TP47).	a. Output voltage remains high. b. Output voltage decreases.	a. Q41 shorted. b. Proceed to step 6.
6	Measure the voltage at pin 1 of constant-voltage comparator Z1 (between TP11 and the +S sensing terminal).	a. TP11 voltage is about +0.7 volts. b. TP11 voltage is about -0.7 volts.	a. Open sensing lead, open strap between A1 and A2, A5R121 or A5R122 open. b. CR1 open, Z1 or Z2 defective.

Table 5-6. Series Regulator Troubleshooting, Low Output Voltage

STEP	ACTION	RESPONSE	PROBABLE CAUSE
	Make these tests with external source connected as described in step 3 of Table 5-4. Leave the coarse voltage control set to the center of its range while making these tests.		
1	Check turn-off of error amplifier A4Q101 by momentarily shorting base (TP45) to emitter (TP100).	a. Output voltage remains low. b. Output voltage rises.	a. A4Q101 shorted; A4Q102 open, thermal switch A4TS101 open; A4Q103 through A4Q106, A4Q108, or A4Q110 open; A4R150 through A4R165 (as applicable) open; A4CR106 (or A4CR107) shorted. b. Proceed to step 2.
2	Check turn-off of error amplifier Q42 by momentarily shorting base (TP44) to emitter (TP46).	a. Output voltage remains low. b. Output voltage rises.	a. Q42 shorted, CR44 shorted. b. Proceed to step 3.
3	Isolate fault to constant-voltage comparator or constant-current comparator by opening the cathode of CR20.	a. Output voltage rises. b. Output voltage remains low.	a. Z1 defective, open strap between A6 and A7, or shorted A5R123 or A5R124. b. Reconnect CR20 and proceed to step 4.
4	Check turn-on of mixer amplifier Q41 by momentarily shorting base (TP40) to collector (TP41).	a. Output voltage remains low. b. Output voltage rises.	a. Q41, CR40, or CR41 open; Q40 shorted. b. Proceed to step 5.
5	Measure the voltage at pin 1 of constant-voltage comparator Z1 (between TP11 and the +S sensing terminal).	a. TP11 voltage is about -0.7 volts. b. TP11 voltage is about +0.7 volts.	a. Open strap between A2 and A3; CR3, CR7, or Q1 shorted; VR1, R3, R4, or R5 open. b. CR1, CR4, Z1 or Z2 defective.



Table 5-7. Preregulator Troubleshooting (See Figure 4-4 for Waveforms)

STEP	ACTION	RESPONSE	PROBABLE CAUSE
1	Connect oscilloscope between TP85 (+) and TP103 (-).	a. Normal waveform. b. Little or no voltage.	a. Proceed to step 2. b. Defective Q72, Q73, CR76, or C71. Proceed to step 3.
2	Connect oscilloscope between TP89 (+) and TP86 (-).	a. Normal waveform b. Little or no voltage.	a. Defective A2CR1, A2L1, T1, A2C1, A2C3. b. Defective T70, CR88, R88, Proceed to step 3.
		<b>WARNING</b>	
<i>To avoid a potentially lethal shock hazard, an isolation transformer must be inserted in the AC power input leads between the power source and the input terminals of TB1 on the rear panel of power supply.</i>			
3	Connect oscilloscope between TP80 (+) and TP103 (-).	a. Amplitude incorrect. b. Period incorrect.	a. Defective Q71, C70, C72, CR74, CR75, R75, R78, or R82. b. CR78 defective. Proceed to step 4.
4	Connect oscilloscope between TPW (+) and TP103 (-).	Amplitude, dc reference, or period incorrect.	Defective CR77, CR78, CR79, CR80, CR82, CR84. Check R87.
5	Connect oscilloscope between TP81 (+) and TP103 (-).	Amplitude, dc reference, or period incorrect.	Defective CR81, CR83, R83, R86, C73.

Table 5-8. Checks and Adjustments Required After Semiconductor Replacement

REFERENCE	FUNCTION OR CIRCUIT	CHECK	ADJUST
Z1	Constant voltage and constant current differential amplifiers.	Constant voltage (CV) line and load regulation. Zero volt output. Constant current (CC) line and load regulation. Zero current output.	R110, or RI13 (Option 020 or 040); R1 17, or RI 19 (Option 021 or 040). See para. 5-81 thru 5-85 or 5-91 thru 5-95 as applicable).
Q1	Voltage clamp circuit.	CC load regulation	---
Q20	Short circuit protection.	Output current.	---
Q40, Q41	Mixer amplifier.	CV/CC load regulation. CV transient response.	R47 (See para. 5-98).
042, A4Q101, A4Q102	Driver and error amplifiers.	CV/CC load regulation.	---
Q60, 061, 062, Q63	Reference regulator.	+12.4V, +6.2V, and -6.2V reference voltages and reference circuit line regulation.	---
Q70	Overvoltage limit.	Limiting action and level.	---

Table 5-8. Checks and Adjustments Required After Semiconductor Replacement (Continued)

REFERENCE	FUNCTION OR CIRCUIT	CHECK	ADJUST
Q71, Q72 Q73	Preregulator control circuit.	Output voltage, ripple imbalance, and preregulator waveforms.	R70, R82 (See para. 5-100 and 5-102).
Q90, Q91 Q92	Crowbar.	Crowbar action, trip voltage, voltage across series regulator when tripped.	A5R125 (See para. 5-104).
A4Q103 thru A4Q106, A4Q108, or A4Q110 (as applicable)	Series regulator.	CV/CC load regulation.	----
A2CR1	Preregulator.	Output voltage.	R70 (See para. 5-102).
CR1, CR20	CV/CC OR gate.	CV/CC crossover operation.	----
CR2, CR3	Voltage clamp circuit.	CC load regulation.	----
CR4, CR40. CR41	Temperature stabilizing diodes.	Temperature coefficient.	----
CR5, CR6, CR21	Limiting diodes.	CV/CC load regulation.	----
CR7, CR60, CR61, CR62.	Reference regulator.	+12.4V, +6.2V, and -6.2V reference voltages.	----
CR35, CR36, CR37.	Turn-on circuit.	Preregulator and series regulator turn-on delay.	----
CR43, CR45 thru CR49, CR53, CR64	Bias supply.	+11V, -4V, and -2.4V bias voltages.	----
CR44, CR50	Driver and error amplifier.	Down-programming speed, CV/CC load regulation.	----
CR70, CR71	Overvoltage limit circuit.	Limiting action and level.	----
CR72 thru CR84, CR88	Preregulator control.	Output voltage, ripple imbalance, and preregulator waveforms.	R70, R82 (See para. 5-100 and 5-102).
CR90 thru CR93, A4CR108, A4CR110	Crowbar.	Trip voltage, voltage across series regulator when crowbar is tripped, supply stability.	R95, A5R125 (See para. 5-104 and 5-106).
A4CR101 and A4CR102,or A4CR101 thru A4CR104.	Main rectifier diodes.	Voltage across main filter capacitors.	----

Table 5-8. Checks and Adjustments Required After Semiconductor Replacement (Continued)

REFERENCE	FUNCTION OR CIRCUIT	CHECK	ADJUST
A4CR105 and A4CR106	Reverse voltage protection.	Output voltage.	— — —
VR1	Voltage clamp circuit.	CC load regulation.	— — —
VR40	Mixer amplifier stabilization diode.	CV transient response.	R47 (See para. 5-98).
VR60, VR61	Reference regulator.	+6.2V and -6.2V reference voltages.	— — —
VR90	Crowbar.	Trip voltage.	R95, A5R125 (See Para. 5-104 and 5-106).

**WARNING**

*Filter capacitors remain charged after shutdown. Discharge capacitors with a shorting resistor.*

**5-60 Disassembly Procedures**

5-61 The following seven paragraphs describe the procedures for removing and disassembling the five sub-assemblies in this supply. These procedures are referred to throughout the manual where necessary.

**5-62 A1 Main Circuit Board Removal.** To remove the main printed circuit board, proceed as follows (Fig. 6-7):

- a. Disconnect input power and remove top cover from supply.
- b. Remove six hold-down screws visible on component side of main circuit board.
- c. Unplug board from receptacle mounted on inter-connection circuit board by gently pulling on finger hole in opposite end of circuit board. Only finger hole should be used to remove board; do not pull on board-mounted components to aid removal. Take care that rear barrier strip clears opening in rear panel.

**5-63 A5 Front Panel Removal.** To remove the front panel, proceed as follows (Figs, 3-1, 6-3, 6-4):

- a. Disconnect input power, turn supply upside down, and remove four screws holding handles to front panel.
- b. The front panel may now be swung outward, hinging on wires to circuit breaker, Access is provided to all panel-mounted components.

**5-64 Main Filter Capacitor Bank Removal.** To remove the main filter capacitors (C101 through C103, C104, or C105 depending on the power supply model), proceed as follows (Figs. 3-1, 6-3, 6-4):

- a. Disconnect input power and remove top and bottom covers from the supply.
- b. Remove the long flat-head screws and V-shaped clamps that hold the main filter capacitors in place. Sufficient lead length is provided to allow capacitors to be lifted partially out of instrument.

**WARNING**

*High temperatures exist on the heat sink after shutdown.*

**5-65 A2 RFI Filter Assembly Removal.** To remove the RFI assembly, proceed as follows (Fig. 6-1):

- a. Disconnect input power, turn supply upside down, and remove bottom cover.
- b. Remove four screws holding RFI heat sink to mounting brackets.

**NOTE**

*At reassembly, do not overtighten these screws.*

- c. Lift out RFI assembly and turn over.
- d. Remove four screws holding cover to heat sink. This allows access to the internal components and 115V/230V jumpers.

**5-66 A4 Heat Sink Removal.** In order to gain access to the following components, it is necessary to remove the heat sink assembly: Transistors A4Q101 through A4Q110; diodes A4CR101 through A4CR108, and A4CR110; resistors A4R106, A4R123, and A4R150 through A4R165; capacitors A4C1 through A4C5; cooling fan A4B1; and thermal switch A4TS101. For the location of these components, see Figures 6-5 and 6-6. To remove the heat sink assembly, proceed as follows:

- a. Disconnect input power from the supply, stand it on its left side, and remove top and bottom cover.
- b. Remove main printed circuit board as described in paragraph 5-62.
- c. Remove two screws holding upper edge of heat sink to upper chassis flange (marked "A" in Figure 6-4).
- d. Disengage two pins holding lower section of heat sink assembly to main circuit board support tray by sliding heat sink down about 1/2 inch and slightly away from chassis. Before fully removing heat sink assembly, observe lead dress so assembly may be returned easily to correct position.
- e. Maneuver heat sink assembly downwards and away

from chassis until it is resting on table (sufficient lead length is provided). Gentle leverage with a thin screwdriver may be necessary to allow heat sink assembly to clear upper chassis flange. Access is now provided to all components mounted on heat sink except resistors A4R150 through A4R165, and A4R123.

**5-67 A4 Heat Sink Disassembly.** To gain access to resistors A4R123 and A4R150 through A4R165, it is necessary to disassemble the heat sink assembly as follows (Figs. 6-3 through 6-6):

- a. Remove heat sink assembly as described in paragraph 5-66 above.
- b. Turn supply upside down and place heat sink assembly partially into chassis so fan (A4B1) is protruding above chassis.
- c. Remove four nuts and four shoulder washers attaching fan mounting plate to heat sink. Do not remove fan from mounting plate. When reassembling heat sink, do not overtighten these screws. Too much tension will damage the insulating rods.
- d. Remove two screws holding current sampling resistor A4R123 to heat sink. If necessary, the resistor may be unsoldered at this point.
- e. Remove mounting nuts from A4CR106 (and A4CR107) on left side of heat sink, and from A4CR108 on right side of heat sink. Remove mounting nuts, bolts and shoulder washers from transistor A4Q102 on right side of heat sink (see Figure 7-5).
- f. Slide this section of heat sink forward and off insulating rods.
- g. Remove four screws holding emitter resistor circuit board to adjoining heat sink section. Access is now provided to series regulator emitter resistors A4R150 through A4R165 (see Figure FO-2).
- h. To remove emitter resistor circuit board completely, unsolder connections to board, marking wires to permit proper replacement.

**5-68 A3 Interconnection Circuit Board Removal.** To replace capacitor A3C3 or transformer A3T2, (shown in Figure 6-2), it is necessary to remove the interconnection circuit board. Perform the following procedure:

- a. Remove main circuit board, RFI assembly, and heat sink assembly as described in paragraphs 5-62, 5-65, and 5-66 (see Fig. 6-1 and Figs. 6-4 through 6-7).
- b. Remove six screws holding back panel to chassis frame.
- c. Stand supply on left side, and remove two screws holding main circuit board support tray to back panel. Move panel away from frame.
- d. Remove two screws holding main circuit board support tray to internal chassis divider.
- e. Working from top rear of supply, interconnection circuit board (still attached to main circuit board support

tray) can be angled up enough to allow access.

- f. If necessary to completely remove interconnection circuit board, remove two screws holding board to support tray, one screw holding A3C3 capacitor clamp to support tray, and two screws holding bias transformer A3T2 to support tray. Unsolder connections to board, marking wires to enable correct replacement, and remove board.

## 5-69 REPAIR AND REPLACEMENT

5-70 The RPSTL for this manual contains a list of replaceable parts. After replacing a semiconductor device, refer to Table 5-6 for checks and adjustments that may be necessary. All components listed in Table 5-8 without A-designators are on the A1 main printed circuit board.

## 5-71 ADJUSTMENT AND CALIBRATION

5-72 Adjustment and calibration may be required after performance testing, troubleshooting, or repair and replacement. Perform only those adjustments that affect the operation of the faulty circuit.

### 5-73 Meter Zero Adjustment

5-74 The meter pointer must rest on the zero calibration mark on the meter scale when the instrument is at normal operating temperature, resting in its normal operating position, and turned off. To zero the meter proceed as follows:

- a. Connect load resistor of value shown in Figure 5-1, turn on instrument, and allow it to come up to normal operating temperature (about 30 minutes).
- b. Turn instrument off and wait two minutes for power supply capacitors to discharge completely.
- c. Insert pointed object (pen point or awl) into small indentation near top of round black plastic disc located directly below meter face.
- d. Rotate plastic disc clockwise until meter reads zero, then rotate counterclockwise slightly in order to free adjustment screw from meter suspension. Pointer should not move during latter part of adjustment.

### 5-75 Voltmeter Calibration

(Figs. 3-1, 6-7)

5-76 To calibrate the voltmeter, proceed as follows:

- a. Connect digital voltmeter across plus and minus output terminals of supply, observing correct polarity.
- b. Turn on supply and adjust VOLTAGE controls until digital voltmeter reads exactly the maximum rated output voltage.
- c. Adjust R106 until front panel voltmeter also

indicates exactly the maximum rated output voltage.

**5-77 Ammeter Calibration**

(Figs. 3-1, 6-7)

- 5-78 To calibrate the ammeter, proceed as follows:
- Connect test setup shown in Figure 5-7.
  - Turn VOLTAGE controls fully clockwise.
  - Turn on supply and adjust CURRENT controls until digital voltmeter reads 500mV.
  - Adjust R101 until front panel ammeter indicates exactly maximum rated output current.

**5-79 Constant-Voltage Programming Calibration**

(Figs. 2-1,3-1, 6-7)

5-80 To calibrate the zero voltage programming accuracy, proceed as directed in paragraph 5-81, 5-82, 5-83, 5-84, or 5-85, whichever applies to your particular instrument. To calibrate the constant voltage programming accuracy, proceed as directed in paragraph 5-86, 5-87 or 5-88.

**5-81 Zero Output Voltage, Standard Instrument With Resistance or Unity-Gain Voltage Programming.**

For instruments using either local programming or the remote programming setup shown in Figure 3-4 or 3-5, zero the output voltage as follows:

- Connect digital voltmeter between +OUT and -OUT bus bars.
- If unit is to be used in local programming mode, turn VOLTAGE controls fully counterclockwise. If unit is to be used in remote programming mode, connect remote programming setup and adjust remote resistance or voltage to zero.
- Connect decade resistance box between pads in zero adjust section of A1 main circuit board that are marked "A" and "B" in Figure 5-9. (These pads are for R110).
- Rotate CURRENT controls fully clockwise and turn on supply.
- Adjust decade resistance box until digital voltmeter reads exactly zero volts.
- Replace decade resistance box with fixed, metal film, 1%, 1/4 or 1/8 watt resistor of same value.

**5-82 Zero Output Voltage, Standard Instrument With Variable Gain Voltage Programming.**

For instruments using the programming setup shown in Figure 3-6, zero the output voltage as follows:

- Perform steps (a) and (b) of paragraph 5-81.
- Solder a jumper between pads in zero adjust section of A1 main circuit board that are marked "C" and "D" in Figure 5.9.
- Connect decade resistance box between pads marked "E" and "F" in Figure 5-9. (These pads are for resistor R111).

d. Perform steps (d) through (f) of paragraph 5-81.

**5-83 Zero Output Voltage, Option 020 Instrument With Resistance or Unity-Gain Voltage Programming.**

For Option 020 instruments using either local programming or the remote programming setup shown in Figure 3-4 or 3-5, zero the output voltage as follows:

- Perform steps (a) and (b) of paragraph 5-81.
- Rotate CURRENT controls fully clockwise and turn on supply.
- If reading on digital voltmeter is not exactly zero volts, adjust potentiometer R113 (labeled "VOLTAGE ZERO" and accessible through hole in rear panel) until reading is exactly zero.

**5-84 Zero Output Voltage, Option 020 Instrument With Variable Gain Voltage Programming.**

For Option 020 instruments using the programming setup shown in Figure 3-6, zero the output voltage as follows:

- Perform steps (a) and (b) of paragraph 5-81.
- Rotate CURRENT controls fully clockwise and turn on supply.
- If reading on digital voltmeter is not exactly zero volts, adjust potentiometer R112 (labeled "VOLTAGE PROG" and accessible through hole in rear panel) until reading is exactly zero.

**5-85 Zero Output Voltage, Option 040 Instrument.**

Zero the output voltage of Option 040 instruments as follows:

- Connect digital voltmeter between +OUT and -OUT bus bars.
- Connect a 10Ω ±1% programming resistor as shown in Figure 3-4.
- Rotate CURRENT controls fully clockwise and turn on supply.
- Adjust potentiometer R113 (labeled "VOLTAGE ZERO" and accessible through hole in rear panel) until reading is zero volts ±1mV.

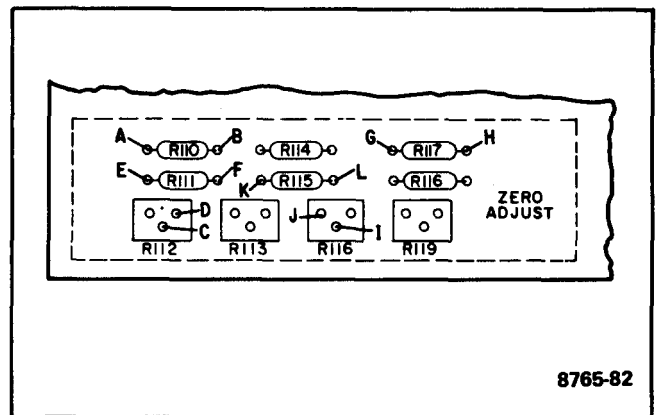

Figure 5-9. Zero Adjust Section of Main Circuit Board

**5-92 Zero Output Current, Standard Instrument**

**With Variable Gain Voltage Programming.** For instruments using the remote programming setup shown in Figure 3-9, zero the output current as follows:

- a. Perform steps (a) and (b) of paragraph 5-91.
- b. Solder a jumper between pads in zero adjust section of A1 main circuit board that are marked "I" and "J" in Figure 5-9.
- c. Connect decade resistance box between pads marked "K" and "L" in Figure 5-9. (These pads are for R115.)
- d. Perform steps (d) through (f) of paragraph 5-91.

**5-93 Zero Output Current, Option 021 Instrument**

**With Resistance or Fixed Gain Voltage Programming.**

For Option 021 instruments using either local programming or the remote programming setup shown in Figure 3-7 or 3-8, zero the output current as follows:

- a. Perform steps (a) and (b) of paragraph 5-91.
- b. Rotate VOLTAGE controls fully clockwise and turn on supply.
- c. If reading on digital voltmeter is not exactly zero volts, adjust potentiometer R119 (labeled "CURRENT ZERO" and accessible through hole in rear panel) until reading is exactly zero.

**5-94 Zero Output Current, Option 021 Instrument**

**With Variable Gain Voltage Programming.** For Option 021 instruments using the programming setup shown in Figure 3-9, zero the output current as follows:

- a. Perform steps (a) and (b) of paragraph 5-91.
- b. Rotate VOLTAGE controls fully clockwise and turn on supply.
- c. If reading on digital voltmeter is not exactly zero volts, adjust potentiometer R116 (labeled "CURRENT PROG" and accessible through hole in rear panel) until reading is exactly zero.

**5-95 Zero Output Current, Option 040 Instrument.**

Zero the output current of Option 040 instruments as follows:

- a. Connect test setup shown in Figure 5-7, except omit load resistor  $R_L$  and connect just current sampling resistor  $R_s$  across the output of the supply.
- b. Connect remote programming setup shown in Figure 3-7 and adjust remote resistance to zero.
- c. Rotate VOLTAGE controls fully clockwise and turn on supply.
- d. If reading on digital voltmeter is not exactly zero volts, adjust potentiometer R119 (labeled "CURRENT ZERO" and accessible through hole in rear panel) until reading is zero volts  $\pm 2mV$ .

**5-96 Constant-Current Programming Accuracy,**

**Standard Instrument.** To calibrate the constant-current programming current of a standard instrument, proceed

as follows:

- a. Connect test setup shown in Figure 5-7.
- b. Disconnect strap between terminals A5 and A6 on rear barrier strip.
- c. Connect 0.1%, 1/8 watt resistor of value shown below between terminals A4 and A6 on rear barrier strip.

Model	Value
6259B	20 $\Omega$
6260B	20 $\Omega$
6261B	20 $\Omega$
6268B	18 $\Omega$
6269B	20 $\Omega$

- d. Connect decade resistance box in place of R30 (mounted on standoffs on main circuit board; see Figure 7-7).
- e. Rotate VOLTAGE controls fully clockwise and turn on supply.
- f. Adjust decade resistance box until digital voltmeter indicates exactly 0.5Vdc.
- g. Replace decade resistance box with fixed, composition, 5%, 1/2 watt resistor of same value.

**5-97 Constant-Current Programming Accuracy, Option 021 or Option 040 Instrument.** To calibrate the constant-current programming current of an Option 021 or Option 040 instrument, proceed as follows:

- a. Perform steps (a) through (c) of paragraph 5-96.
- b. Rotate VOLTAGE controls fully clockwise and turn on supply.
- c. Adjust potentiometer R116 (labeled "CURRENT PROG" and accessible through hole in rear panel) until digital voltmeter indicates 0.5Vdc  $\pm 10mV$ .

**5-98 Load Transient Recovery Time Adjustment (Figs. 3-1, 6-7)**

5-99 To adjust the transient response, proceed as follows:

- a. Connect test setup shown in Figure 5-4.
- b. Repeat steps (a) through (k) as outlined in paragraph 5-30.
- c. Adjust R47 until transient response to within specification as shown in Figure 5-5.

**5-100 Ripple Balance Adjustment (Figs. 3-1, 6-7)**

5-101 This procedure ensures balanced triac operation by ensuring that its conduction time is within 25% of being equal in both directions. To check for imbalance, proceed as follows:

- a. Connect load resistor specified in Figure 5-1 across rear output terminals of supply (Fig. 2-1).
- b. Connect variable autotransformer between input power source and power supply input and adjust it for a 115 Vac input to the supply.

c. connect ac-coupled oscilloscope across series regulator (between \*TP102 and \*TP103) (Fig. FO-1).

\*Test points are identified on schematic only.

**5-92 Zero Output Current, Standard Instrument**

**With Variable Gain Voltage Programming.** For instruments using the remote programming setup shown in Figure 3-9, zero the output current as follows:

- a. Perform steps (a) and (b) of paragraph 5-91.
- b. Solder a jumper between pads in zero adjust section of A1 main circuit board that are marked "I" and "J" in Figure 5-9.
- c. Connect decade resistance box between pads marked "K" and "L" in Figure 5-9. (These pads are for R115.)
- d. Perform steps (d) through (f) of paragraph 5-91.

**5-83 Zero Output Current, Option 021 Instrument**

**With Resistance or Fixed Gain Voltage Programming.**

For Option 021 instruments using either local programming or the remote programming setup shown in Figure 3-7 or 3-8, zero the output current as follows:

- a. Perform steps (a) and (b) of paragraph 5-91.
- b. Rotate VOLTAGE controls fully clockwise and turn on supply.
- c. If reading on digital voltmeter is not exactly zero volts, adjust potentiometer R119 (labeled "CURRENT ZERO" and accessible through hole in rear panel) until reading is exactly zero.

**5-94 Zero Output Current, Option 021 Instrument**

**With Variable Gain Voltage Programming.** For Option 021 instruments using the programming setup shown in Figure 3-9, zero the output current as follows:

- a. Perform steps (a) and (b) of paragraph 5-91.
- b. Rotate VOLTAGE controls fully clockwise and turn on supply.
- c. If reading on digital voltmeter is not exactly zero volts, adjust potentiometer R116 (labeled "CURRENT PROG" and accessible through hole in rear panel) until reading is exactly zero.

**5-95 Zero Output Current, Option 040 Instrument.**

Zero the output current of Option 040 instruments as follows:

- a. Connect test setup shown in Figure 5-7, except omit load resistor  $R_L$  and connect just current sampling resistor  $R_s$  across the output of the supply.
- b. Connect remote programming setup shown in Figure 3-7 and adjust remote resistance to zero.
- c. Rotate VOLTAGE controls fully clockwise and turn on supply.
- d. If reading on digital voltmeter is not exactly zero volts, adjust potentiometer R119 (labeled "CURRENT ZERO" and accessible through hole in rear panel) until reading is zero volts  $\pm 2mV$ .

**5-96 Constant-Current Programming Accuracy,**

**Standard Instrument.** To calibrate the constant-current programming current of a standard instrument, proceed

as follows:

- a. Connect test setup shown in Figure 5-7.
- b. Disconnect strap between terminals A5 and A6 on rear barrier strip.
- c. Connect 0.1%, 1/8 watt resistor of value shown below between terminals A4 and A6 on rear barrier strip.

Model	Value
6259B	20 $\Omega$
6260B	20 $\Omega$
6261B	20 $\Omega$
6268B	18 $\Omega$
6269B	20 $\Omega$

- d. Connect decade resistance box in place of R30 (mounted on standoffs on main circuit board; see Figure 7-7).
- e. Rotate VOLTAGE controls fully clockwise and turn on supply.
- f. Adjust decade resistance box until digital voltmeter indicates exactly 0.5Vdc.
- g. Replace decade resistance box with fixed, composition, 5%, 1/2 watt resistor of same value.

**5-97 Constant-Current Programming Accuracy, Option**

**021 or Option 040 Instrument.** To calibrate the constant-current programming current of an Option 021 or Option 040 instrument, proceed as follows:

- a. Perform steps (a) through (c) of paragraph 5-96.
- b. Rotate VOLTAGE controls fully clockwise and turn on supply.
- c. Adjust potentiometer R116 (labeled "CURRENT PROG" and accessible through hole in rear panel) until digital voltmeter indicates 0.5Vdc  $\pm 10mV$ .

**5-98 Load Transient Recovery Time Adjustment (Figs. 3-1, 6-7)**

5-99 To adjust the transient response, proceed as follows:

- a. Connect test setup shown in Figure 5-4.
- b. Repeat steps (a) through (k) as outlined in paragraph 5-30.
- c. Adjust R47 until transient response to within specification as shown in Figure 5-5.

**5-100 Ripple Balance Adjustment (Figs. 3-1, 6-7)**

5-101 This procedure ensures balanced triac operation by ensuring that its conduction time is within 25% of being equal in both directions. To check for imbalance, proceed as follows:

- a. Connect load resistor specified in Figure 5-1 across rear output terminals of supply (Fig. 2-1).
- b. Connect variable autotransformer between input power source and power supply input and adjust it for a 115 Vac input to the supply.

c. connect ac-coupled oscilloscope across series regulator (between \*TP102 and \*TP103) (Fig. FO-1).

\*Test points are identified on schematic only.

- d. Turn CURRENT controls fully clockwise, turn on supply, and adjust VOLTAGE controls for maximum rated output voltage.
- e. Adjust oscilloscope to observe 120Hz sawtooth waveform. Peak amplitudes of adjacent sawtooth peaks should be within 25% of each other.
- f. If amplitude difference is greater than 25%, turn off supply and replace R82 with decade resistance.
- g. Turn on supply and adjust decade resistance to reduce imbalance to within 25%.
- h. Vary input line voltage from 100 to 130 Vac and insure that excessive imbalance does not exist anywhere within this range. Replace decade box with equivalent resistor.

#### NOTE

*If imbalance cannot be reduced to within 25%, check capacitors C70 and C72, and diodes CR79 through CR84. If these components test satisfactorily, the problem may be due to distortion present on the ac power line.*

#### 5-102 Preregulator Tracking Adjustment (Figs. 3-1, 6-7)

- 5-103 To adjust the voltage drop across the series regulator, proceed as follows:
- a. Connect load resistor specified in Figure 5-1 across rear output terminals of supply.
  - b. Connect variable autotransformer between input power source and power supply input and adjust it for a 115Vac input to the supply.
  - c. Connect dc voltmeter across series regulator (between TP102 and TP103) (Fig. FO-1).
  - d. Turn CURRENT controls fully clockwise.
  - e. To check voltage drop across regulator at low output voltage, short circuit the load resistor and adjust VOLTAGE controls for maximum rated output current on front panel ammeter.
  - f. Adjust R70 (RAMP ADJ.) until voltmeter reads 3.5 ±0.3Vdc.
  - g. To check the voltage drop at high output voltage, remove short circuit from across load resistor and adjust VOLTAGE controls for maximum rated output current. Voltmeter reading should again be 3.5 ±0.3Vdc.
  - h. Vary input line voltage from 100 to 130Vac. Voltmeter reading should vary between 3.2 and 3.8Vdc. If reading exceeds this range, proceed to step (i).
  - i. Replace R77 with decade box. Vary input line voltage between 100 to 130Vac and adjust decade box until voltmeter reading variation is minimal and within range of 3.2 to 3.8Vdc. Replace decade box with equivalent resistor.

#### 5-104 Crowbar Trip Voltage Adjustment (Figs. 3-1, 6-3)

- 5-105 To adjust the voltage at which the crowbar fires, proceed as follows:
- a. Turn front panel OVERVOLTAGE ADJUST potentiometer A5R125 fully clockwise.
  - b. Turn on supply.
  - c. Set output voltage to desired trip voltage.
  - d. Turn A5R125 slowly counterclockwise until the crowbar fires (amber OVERVOLTAGE lamp lights and voltmeter indication falls to zero).
  - e. Turn off supply and turn down output voltage controls.
  - f. Turn on supply and set desired output voltage.

#### NOTE

*It is recommended that the crowbar trip voltage be set higher than the normal output voltage by no less than 5% of the output voltage plus 2 volts for the Models 6259B, 6260B, or 6261B, or 5% of the output voltage plus one volt for the Models 6268B or 6269B. If an occasional tripping of the crowbar can be tolerated as a load is being disconnected, the crowbar trip point can be set much closer to the operating voltage of the supply.*

#### 5-106 Maximum Crowbar Trip Voltage Adjustment (Figs. 3-1, 6-3, 6-7, FO-1)

- 5-107 To adjust the maximum voltage at which the crowbar fires, proceed as follows:
- a. Rotate A5R125 (OVERVOLTAGE ADJUST) and CURRENT controls fully clockwise.
  - b. Disconnect one end of R72 (at TP70 or TP71) to temporarily disable the overvoltage limit circuit.
  - c. Connect decade resistance box in place of R95 (mounted on standoffs on main circuit board).
  - d. Turn on supply and adjust VOLTAGE controls for output voltage shown below:
- | Model | Value |
|-------|-------|
| 6259B | 12Vdc |
| 6260B | 12Vdc |
| 6261B | 23Vdc |
| 6268B | 45Vdc |
| 6269B | 45Vdc |
- e. Adjust decade resistance box until crowbar fires.
  - f. Replace decade resistance with appropriate value resistor in R95 position and reconnect resistor R72. Maximum crowbar trip voltage is now set at voltage given in step (d).

#### 5-108 Disabling the Crowbar (Figs. 6-7, FO-1)

- 5-109 To disable the crowbar completely, disconnect either end of R98 at TP96 or TP97 on the main circuit board.



## 5-110 OVERHAUL AND REBUILD

5-111 The following instructions set forth the procedures for completely disassembling the supply for overhaul or rebuild tasks. Before beginning these tasks, the supply is tested to determine whether or not the unit is serviceable. Malfunctions should be noted during the test and the parts responsible should be replaced during the reassembly procedures.

## 5-112 COMPLETE REMOVAL OF A3 INTERCONNECTION BOARD

(Figs. 6-1 through 6-6, FO-3)

5-113 To partially remove the A3 interconnection board, the A1 main circuit board, A2RFI assembly and A4 heat sink assembly must first be fully or partially removed, as prescribed in paragraph 5-68, steps a. through e. The following instructions set forth steps for A3 board removal to a stage where the A3 interconnection board and the A4 heat sink can be removed as an entity (to avoid need for some unsoldering). The two assemblies can then be separated by unsoldering the leads while on the bench, if necessary.

- a. Move heat sink A4 out of chassis according to paragraph 5-66.
- b. Tag and unsolder leads to primary side of bias transformer A3TR.
- c. Move A2 RFI assembly out of chassis according to paragraph 5-65.
- d. Move heat sink A4 and A2 RFI assembly as an entity to the bench.
- e. If the two units must be separated, then unsolder the leads from the unit of interest.
- f. Remove screw that secures A3C3 capacitor clamp to main circuit board support tray.
- g. Remove two screws that secure bias transformer A3T2 to main circuit board support tray.
- h. At A3 board, tag and unsolder leads that run to A5 panel.
- i. Tag and disconnect the heavy leads from A4 heat sink.
- j. Remove A3 board and A4 heat sink together, or tag and unsolder the leads between the two assemblies and move the assembly (intended to be completely removed) to the bench.
- k. Move main circuit board tray to bench.
- l. Separate A3 board from A4 heat sink by tagging and unsoldering leads, if necessary.
- m. Remove grommet from main circuit board support tray, if necessary.

## 5-114 COMPLETE REMOVAL OF A4 HEAT SINK

5-115 The A4 heat sink is partially removed (with wiring still connected) from the chassis by following the procedure in paragraph 5-66. If the A4 heat sink is to be fully removed, it can be removed together with the A3 interconnection board or removed separately. Refer to paragraph 5-112 if A4 heat sink is to be fully removed.

## 5-116 POWER TRANSFORMER T1 REMOVAL

(Figs. 6-3, 6-4, FO-3)

5-117 To remove the power transformer T1, perform the following procedure:

- a. Set chassis on its right side.
- b. Tag and unsolder leads from terminals on secondary side of transformer T1.
- c. Tag and disconnect leads fastened to terminals 6 and 7 of primary power transformer T1.
- d. Remove four mounting nuts and washers from T1. Lift transformer out through the top side of chassis and move to bench.

## 5-118 B2 FAN REMOVAL

(Figs. 6-2 through 6-4, FO-3)

5-119 To remove fan B2, the A3 interconnection board must be at least partially removed so that the fan leads of fan B2 can be unsoldered from terminals of bias transformer A3T2.

- a. Partially remove board A3 as per paragraph 5-68.
- b. Tag and unsolder two fan leads from terminals of bias transformer A3T2.
- c. Pull fan leads through hole in internal chassis divider.
- d. While holding fan, remove two screws and washers that secure fan to bottom of circuit board tray.
- e. Move fan with its two brackets to bench.
- f. Remove two mounting brackets.

## 5-120 COMPLETE REMOVAL OF MAIN FILTER CAPACITOR BANK

(Figs. 6-3, 6-4, FO-3)

5-121 To remove main filter capacitor bank, perform the following procedure:

- a. Partially remove main filter capacitor bank as per paragraph 5-64.
- b. Remove screw and washers that secure cable clamp to internal chassis divider. (Cable clamp is located next to capacitor bank.)
- c. Tag and disconnect four cables to capacitor bank.
- d. Remove capacitor bank and move to bench.
- e. If a capacitor is to be separated from bank assembly, remove two screws that secure the capacitor to the bus bars and move capacitor to bench.

## 5-122 B BUS BARS (+B, -B) REMOVAL

(Figs. 6-1, 6-2, 6-5, 6-6, FO-3)

5-123 To remove the +B and/or -B bus bar, it is necessary to remove the filter assembly A2 RFI and heat sink A4, as described in paragraphs 5-65 and 5-66.

- a. Tag and disconnect two leads that run inside chassis to A1 main circuit board.

- b. On +B bus bar (inside), tag and disconnect red lead that runs to A3 interconnection board.
- c. Tag and remove capacitor C19 from between the two bus bars.
- d. Tag and disconnect heavy black lead from –B bus bar.
- e. Remove two screws and nylon shoulder washers that secure bus bar to rear panel.
- f. Move bus bar to bench.

**5-124 REMOVAL OF STANDOFF MOUNTS FOR A2 RFI CIRCUIT ASSEMBLY**  
(Figs. 6-1, FO-3)

- 5-125 To gain access to the standoff supports for A2 RFI circuit assembly, the A2 RFI assembly must be moved out of the way.
- a. Remove two screws from rear panel that secure the standoff mount to the rear panel.
  - b. Move mount to bench.
  - c. Remove two screws and nuts that secure front-end standoff mount to the internal chassis divider.
  - d. Move standoff mount to bench.

**5-126 REMOVAL OF INPUT POWER TERMINAL BOARD TB1**  
(Figs. FO-1, FO-3)

- 5-127 To gain access to terminal board TB1, the rear panel must be moved aside.
- a. Remove cable strain relief assembly, if so equipped.
  - b. Tag and disconnect two internal leads that are fastened to terminal board.
  - c. Remove two screws that secure terminal board to rear panel.
  - d. Remove upper screw and nut of the ground terminal (middle terminal) and move terminal board to bench.

**5-128 REMOVAL OF REAR PANEL**  
(Figs. 2-1, 6-9, FO-3)

- 5-129 To remove rear panel, all cables fastened to the two bus bars and to the input terminal board TB1 must be disconnected.
- a. Ensure that all cables are disconnected from bus bars and terminal board CB1. (Paragraphs 5-114, 5-119, and 5-122.)
  - b. Remove three screws and washers that secure rear panel to right side of chassis.
  - c. Remove three screws and washers that secure rear panel to left side of chassis.
  - d. Remove panel from chassis and move to bench.
  - e. If necessary, remove four rubber foot pads and binding post from rear panel.

**5-130 A5 FRONT PANEL REMOVAL**  
(Figs. 6-3, 6-4)

- 5-131 The four screws that secure the two handles to the chassis frame also secure the front panel to the frame.
- a. Set chassis on bench, bottom side down.
  - b. Remove four screws and nuts that secure the two handles to the frame.
  - c. Move handles to bench and rotate front panel downward.

**5-132 A5 FRONT PANEL DISASSEMBLY**  
(Figs. 6-3, 6-4, 6-9, FO-3)

- 5-133 To disassemble the front panel, perform the following procedure:
- a. Tag and disconnect leads to LINE circuit breaker A5CB1.
  - b. Remove four screws that secure A5CB1 to front panel and move A5CB1 to bench.
  - c. Remove two knobs from VOLTAGE/COARSE/FINE potentiometers A5R121 and A5R122.
  - d. Remove two knobs from CURRENT/COARSE/FINE potentiometers A5R123 and A5R124.
  - e. Tag and unsolder leads to the four potentiometers A5R121, A5R122, A5R123 and A5R124.
  - f. Tag four potentiometers, remove hex nuts that secure four potentiometers (steps d. and e.) to front panel, and move to bench.
  - g. Unsolder leads to OVERVOLTAGE ADJUST potentiometer A5R125.
  - h. With a wrench, turn (CCW) hex bushing mount of A5R125 to remove it.
  - i. Unsolder leads from OVERVOLTAGE indicating lamp A5DS2.
  - j. Remove voltage and current meters A5M1 and A5M2.
    - (1) Unsolder two wires from meter.
    - (2) On one side of meter (with a pointed tool), slightly pry out bezel side tab so as to disengage it from the meter.

**NOTE**

*Four meter mount compression springs will become exposed in the next step. Be careful not to lose these springs.*

- (3) An other side of meter, pry out bezel side tab so as to disengage it from meter.
- (4) Move meter to bench.
- (5) Remove four meter mount compression springs from the front side of the meter.

(6) Repeat previous steps for other meter.

k. With needlenose pliers, squeeze (lengthwise) the fastener that secures indicating lampholder XDS1 for OVERVOLTAGE indicating lamp. With a sharp instrument, pry off fastener. Move indicating lamp to bench.

l. Repeat previous steps for other lamp DS1.

### 5-134 COMPLETE UNIT DISASSEMBLY

(Figs. 6-1 through 6-7, FO-3)

5-135 To disassemble the complete unit, perform the following procedure:

#### **WARNING**

*Discharge all components before removal.*

- a. Disconnect input power and remove top and bottom covers.
- b. Remove main circuit board as per paragraph 5-62. Tag and disconnect two leads running to B bus bars.
- c. Remove A2 RFI filter assembly as per paragraph 5-65. Tag and unsolder two leads that run to A3 interconnection circuit board and move A2 RFI to bench.
- d. Partially remove A4 heat sink as per paragraph 5-66. (A4 will

be completely removed together with A3 interconnection circuit board removal in step f.)

e. Partially remove A3 interconnection circuit board as per paragraph 5-68.

f. Completely remove board A3 and heat sink A4 as per paragraphs 5-112 and 5-114.

g. Completely remove transformer T1 as per paragraph 5-116.

h. Completely remove fan B2 as per paragraph 5-118.

i. Remove main capacitor bank as per paragraph 5-120.

j. Remove +B and -B bus bars as per paragraph 5-122.

k. Remove two standoff mounts that act as supports for A2 RFI filter assembly as per paragraph 5-124.

l. Remove input power terminal board CB1 from rear panel as per paragraph 5-126.

m. Remove rear panel as per paragraph 5-128.

n. Remove cable clamp and harness from panel behind A5 front panel.

o. Remove harness and move to bench.

### 5-136 UNIT REASSEMBLY

(Fig. FO-3)

5-137 To reassemble the unit, perform the following procedure:

a. To reassemble or rebuild the supply, reverse the steps of the removal procedure. Replace any faulty parts.

b. Test the supply to ensure that it is operating correctly.



## SECTION VI CIRCUIT DIAGRAM AND COMPONENT LOCATION DIAGRAMS

This section contains the schematic diagram and component location diagrams necessary for maintaining this power supply. Differences among the five power supply models covered by this manual are indicated where they exist. The

test points indicated by circled numbers on the circuit schematic of Figure FO-1 correspond to those on the component location diagrams and in the troubleshooting procedures in Section V.

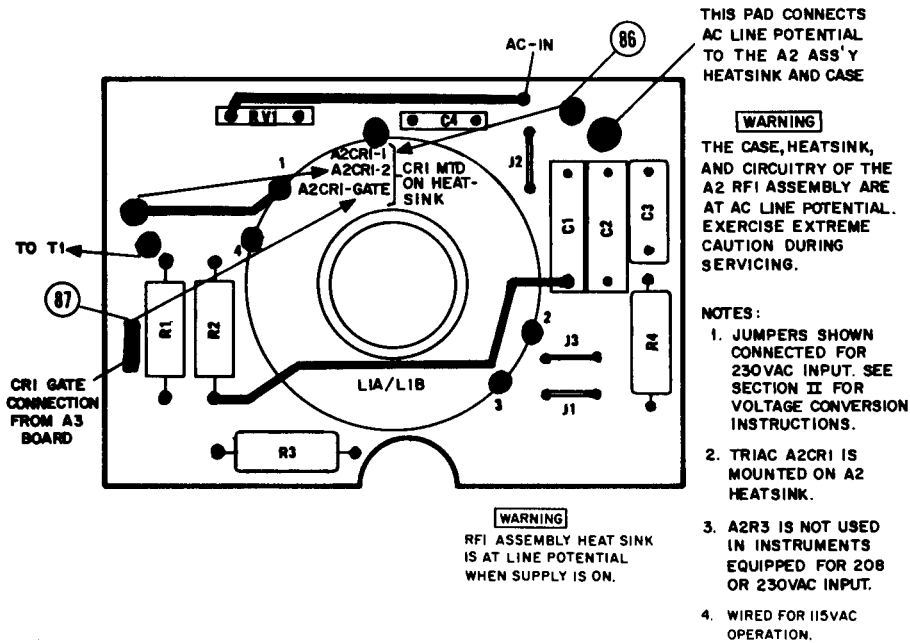

8774-82

Figure 6-1. A2RFI Assembly Component Locations

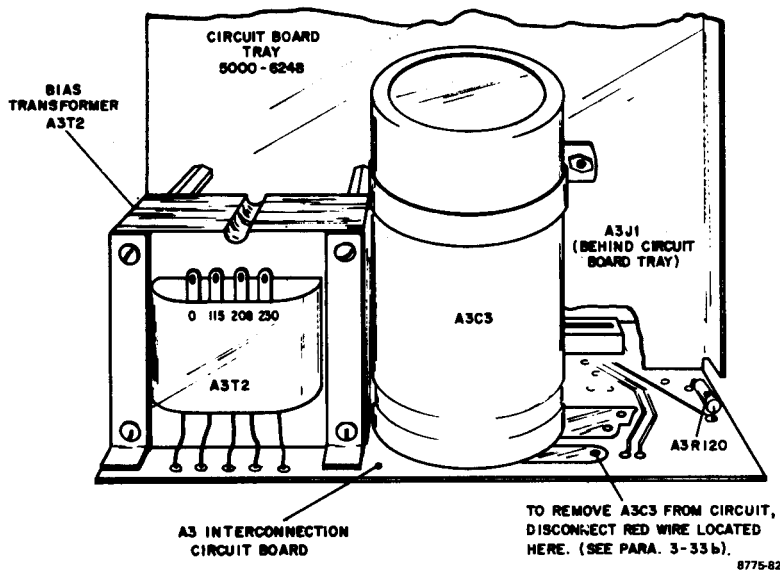

Figure 6-2. A3 Interconnection Board Component Locations

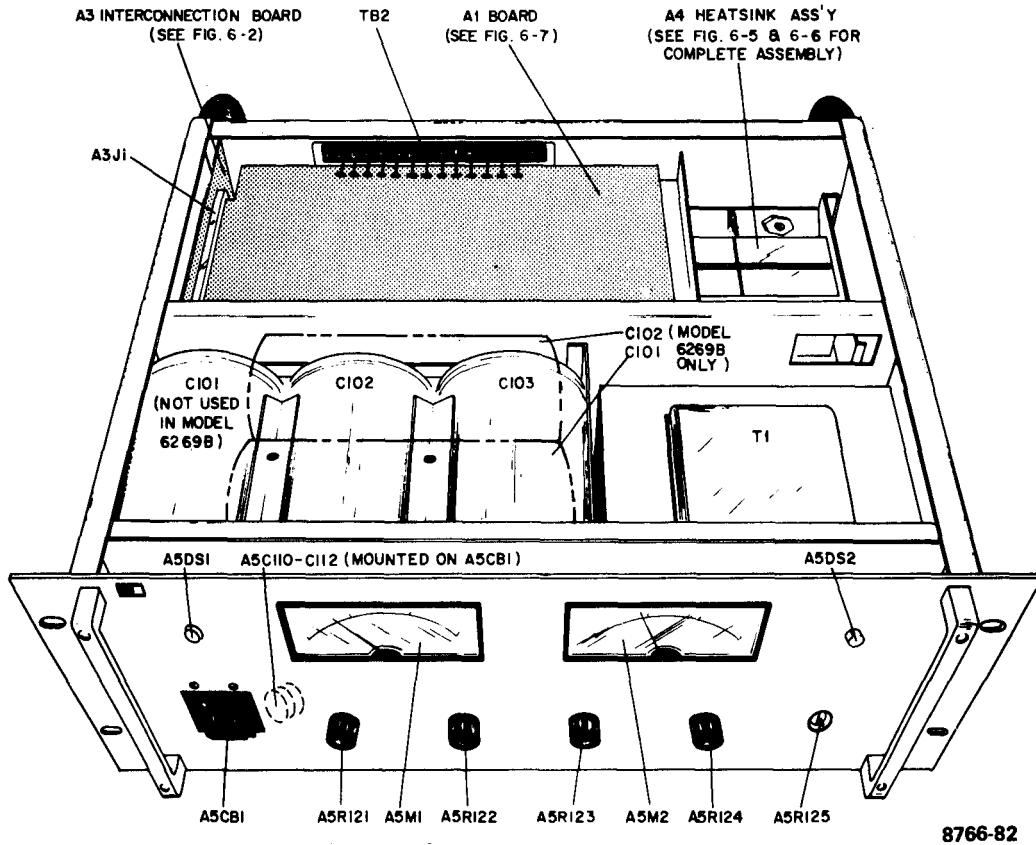

Figure 6-3. Chassis Component Locations, Top View

8766-82

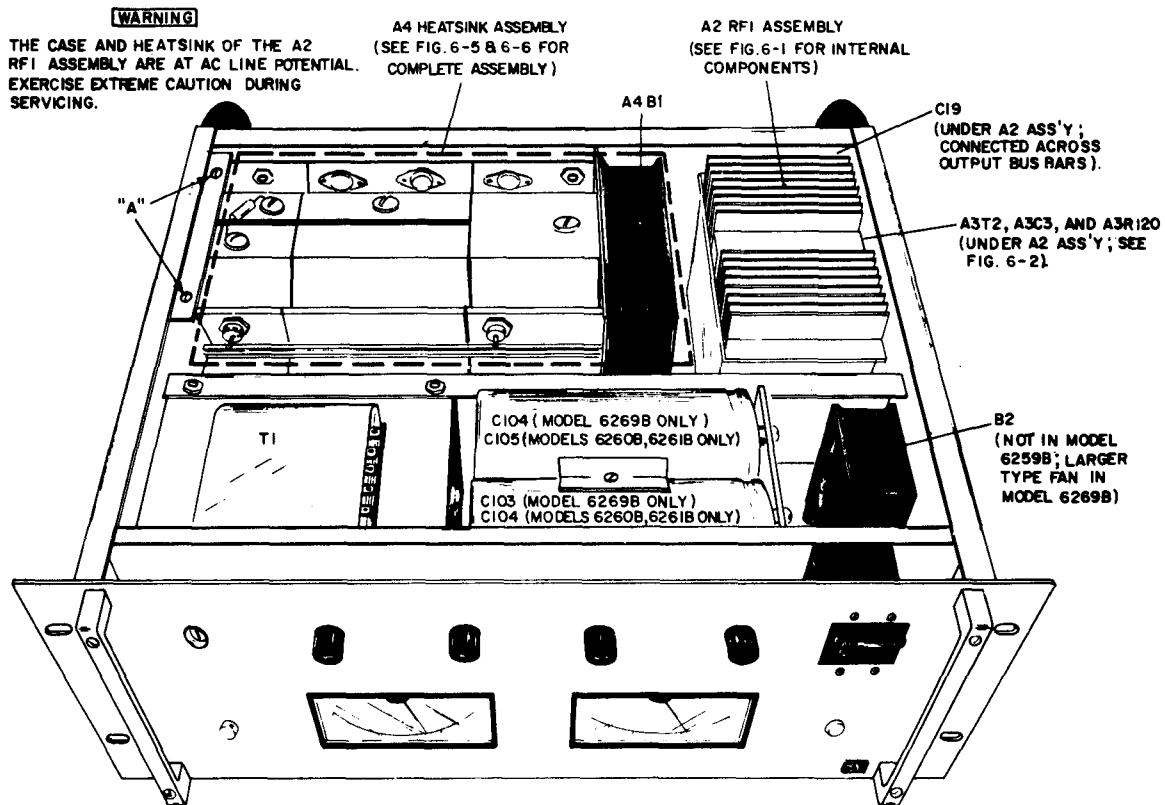
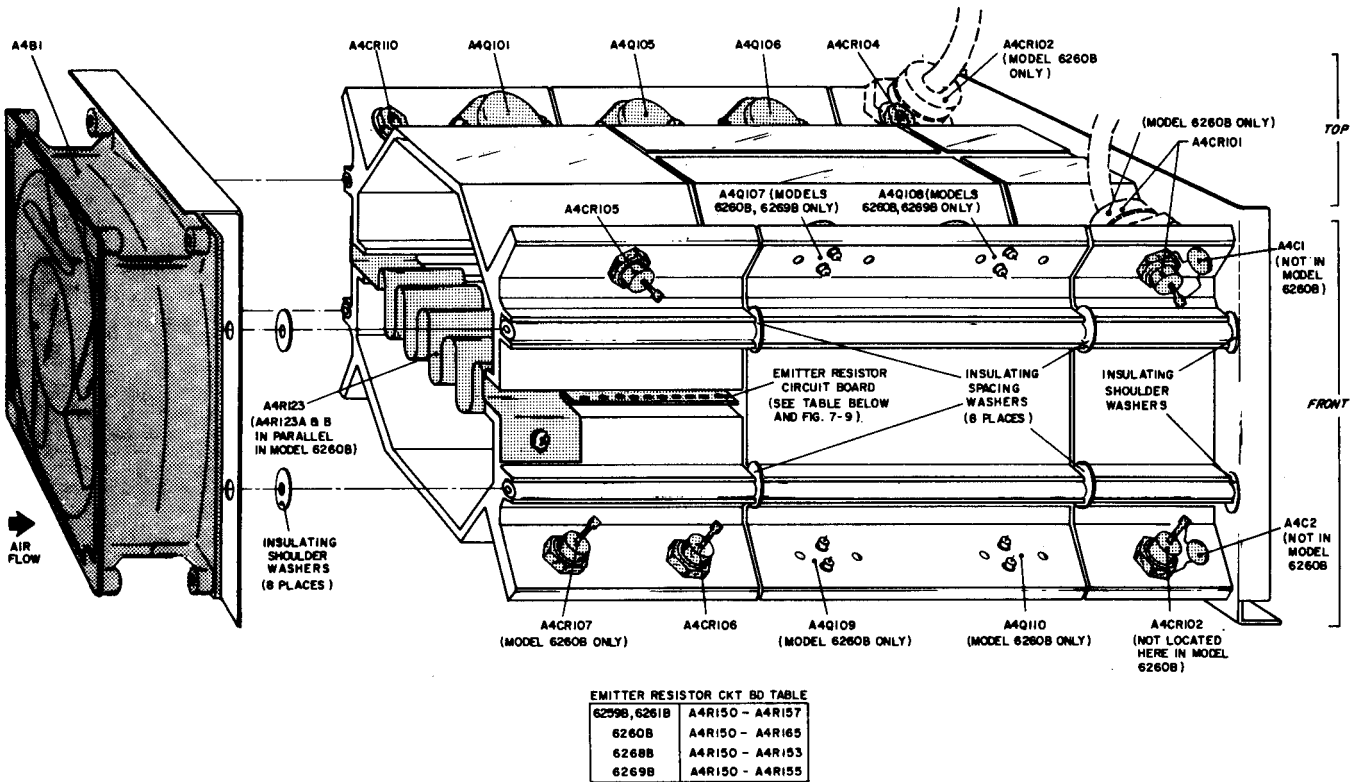

Figure 6-4. Chassis Component Locations, Bottom View

8767-82



8768-82

Figure 6-5. A4 Heatsink Assembly, Top and Front View

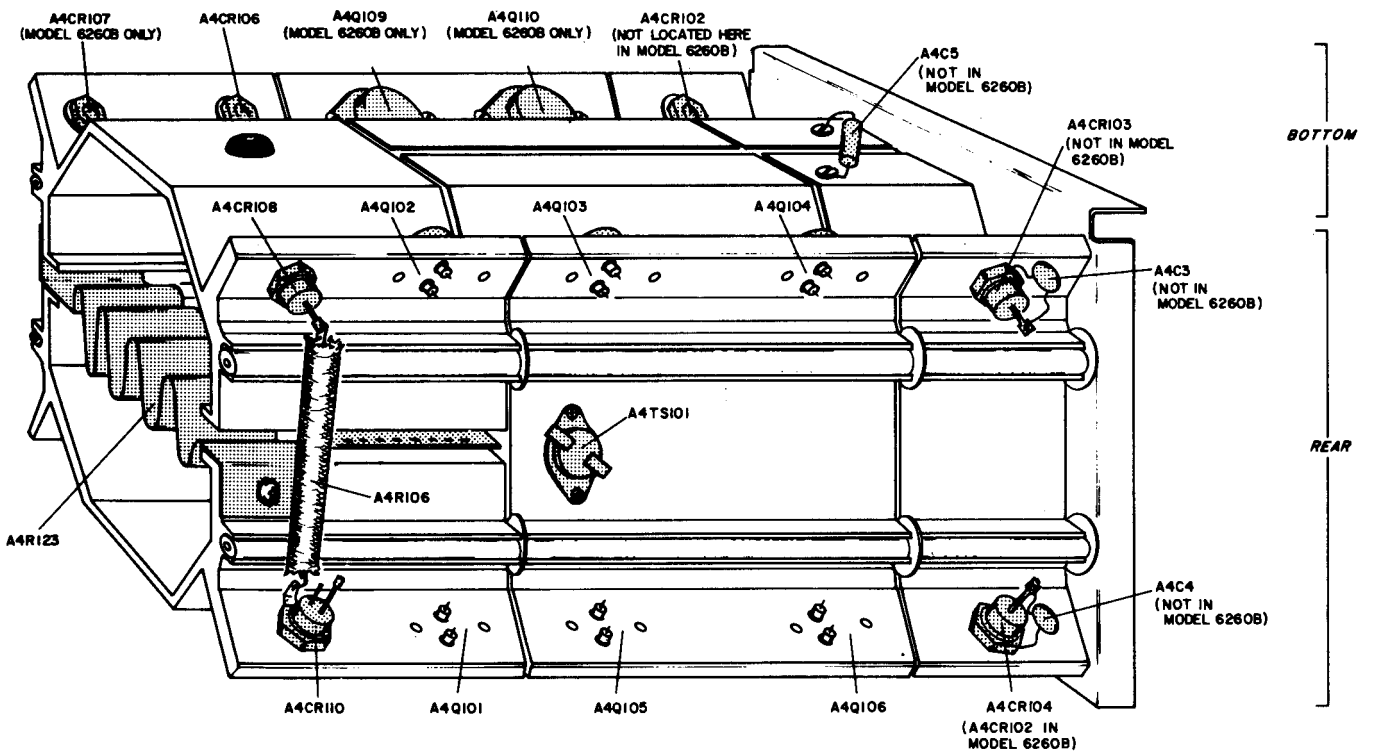

8769-82

Figure 6-6. A4 Heatsink Assembly, Bottom and Rear View

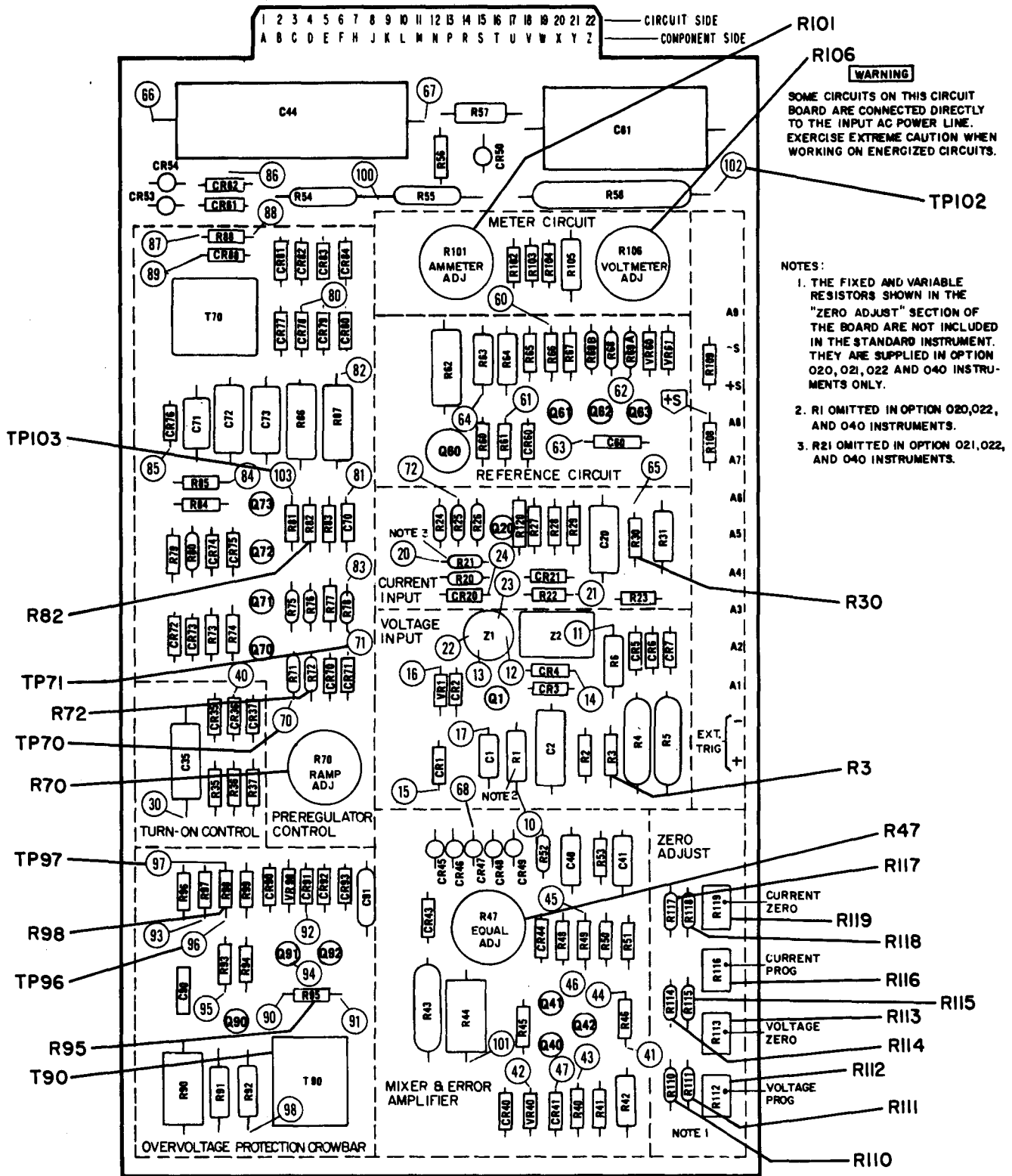

8776-82

Figure 6-7. A1 Board Component Locations



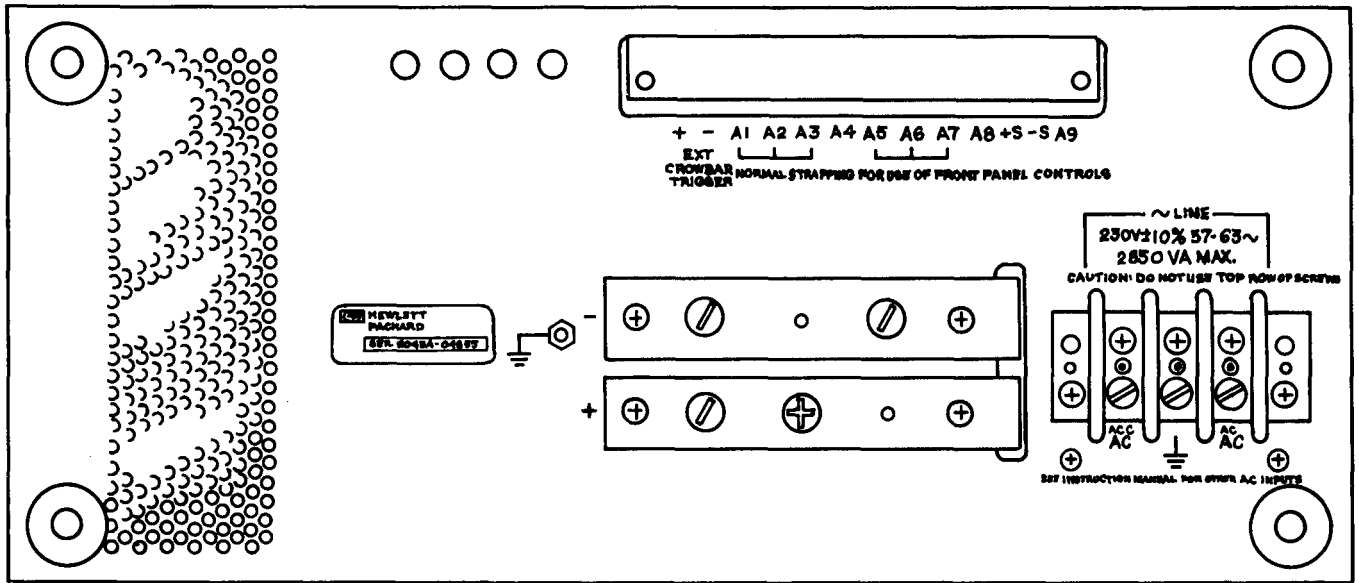

8772-82

Figure 6-8. Rear Panel

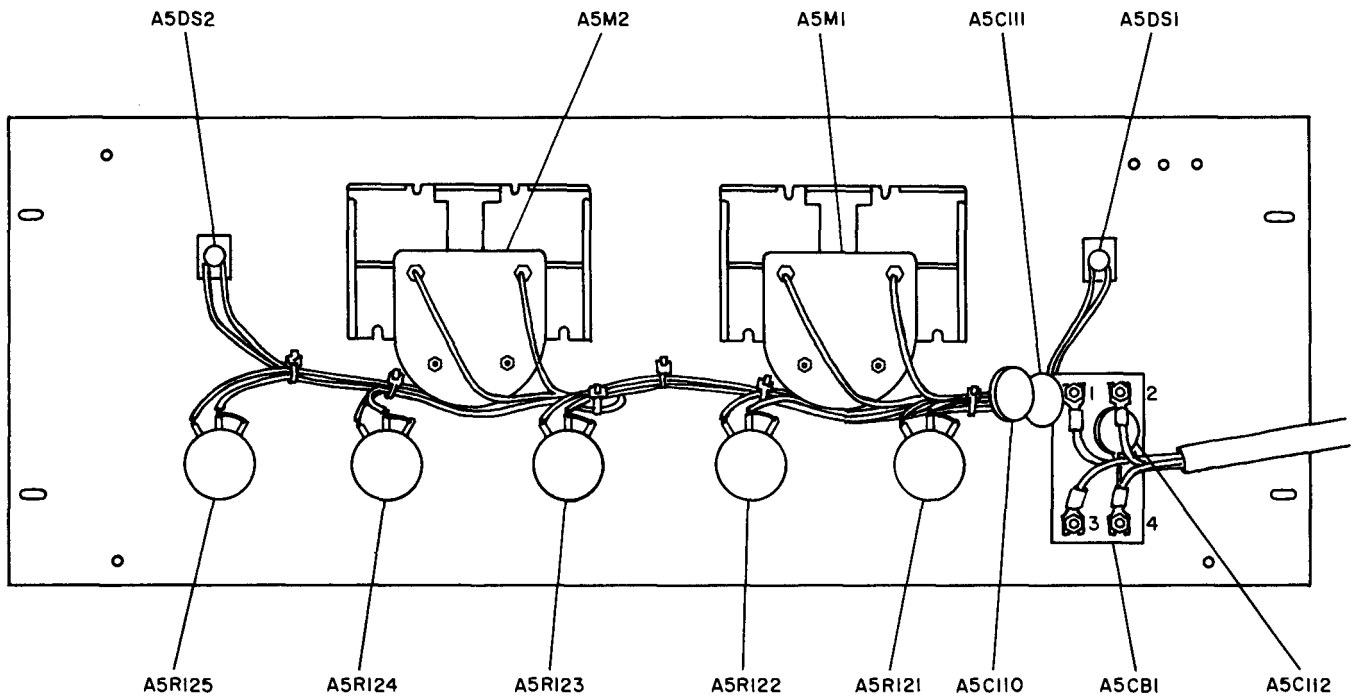

8773-82

Figure 6-9. Rear Side of Front Panel



**APPENDIX A  
REFERENCES**

---

AR 750-56	Painting, Camouflage Painting and Marking of Army Material.
DA PAM 310-1	Consolidated Index of Army Publications and Blank Forms.
SB 11-573	Painting and Preservation Supplies Available for Field Use for Electronics Command Equipment.
TB S1G-22	Solder and Soldering.
TB 43-0116	Identification of Radioactive Items in the Army Supply System.
TB 43-0116	Field Instructions for Painting and Preserving Electronics Command Equipment Including Camouflage Pattern Painting of Electrical Equipment Shelters.
TB 746-10	Field Instructions for Painting and Preserving Electronics Command Equipment.
TB 38-750	The Army Maintenance Management System (TAMMS).
TM 740-90-1	Administrative Storage of Equipment.
TM 750-244-2	Procedures for Destruction of Electronics Materiel to Prevent Enemy Use (Electronics Command).
TM 11-6625-1541-15	Operator, Organizational, Direct Support, General Support and Depot Maintenance Manual: Hewlett-Packard RMS Voltmeter Model 3400A.
TM 11-6625-654-14	Operator, Organizational, Direct Support, General Support, and Depot Maintenance Manual Including Repair Parts and Special Tool Lists for Multimeter AN/USM-223
TM 11-6625-2568-14	Operator, Organizational, Direct Support, and General Support Maintenance Manual for Oscilloscope AN/USM-261C (NSN 6625-00-106-9622).
TM 11-6625-2735-14 0969-LP-170-1090 T.O. 33A1-13-496-1	Operator's, Organizational, Direct Support, and General Support Maintenance Manual (Including Depot Maintenance) for Oscilloscope OS-261/U (NSN 6625-00-127-0079).



## APPENDIX B

### MAINTENANCE ALLOCATION

---

#### Section I. INTRODUCTION

**B-1. General.** This appendix provides a summary of the maintenance operations for the Regulated DC Power Supply Model 6268B. It authorizes categories of maintenance for specific maintenance functions on repairable items and components and the tools and equipment required to perform each function.

**B-2. Maintenance Concept.** Two levels of maintenance shall be utilized for the equipment as follows:

Organizational Level

Depot Level.

a. *Organization Maintenance.* That maintenance which is the responsibility of and performed by a using organization on its assigned equipment. Its phases normally consist of inspecting, servicing, lubricating, and adjusting, and the replacement of parts, minor assemblies and subassemblies. This level is designated by an O in the Maintenance Category columns in Section II.

b. *Depot Maintenance.* That maintenance which is the responsibility of and performed by designated maintenance activities, to augment stocks of serviceable material, and to support lower level activities by the use of more extensive shop facilities, equipment and personnel of higher technical skills than are available at the lower level of maintenance. Its phases normally consist of inspection, test, repair, modification, alteration, modernization, conversion, overhaul reclamation, or rebuild of parts, assemblies, subassemblies, components, equipment end items, and weapon systems; and the manufacture of critical non-available parts. Depot Maintenance is normally accomplished in fixed shops. This level is designated by a D in the Maintenance Category columns in Section II.

**B-3. Maintenance Function.** Maintenance functions for the Regulated DC Power Supply Model 6268B are defined as follows:

a. *Inspect.* To determine the serviceability of an item by comparing its physical, mechanical, and/or electrical characteristics with established standards through examination.

b. *Test.* To verify serviceability and to detect incipient failure by measuring the mechanical or electrical characteristics of an item and comparing those characteristics with prescribed standards.

c. *Service.* Operations required periodically to keep an item in proper operating condition, i.e., to clean (decontaminate), to preserve, to drain, to paint, or to replenish fuel, lubricants, hydraulic fluids, or compressed air supplies.

d. *Adjust.* To maintain, within prescribed limits, by bringing into proper or exact position, or by setting the operating characteristics to the specified parameters.

e. *Align.* To adjust specified variable elements of an item to bring about optimum or desired performance.

f. *Calibrate.* To determine and cause corrections to be made or to be adjusted on instruments or test measuring and diagnostic equipments used in precision measurement. Consists of comparisons of two instruments, one of which is a certified standard of known accuracy, to detect and adjust any discrepancy in the accuracy of the instrument being compared.

g. *Install.* The act of emplacing, seating, or fixing into position an item, part, or module (component or assembly) in a manner to allow the proper functioning of the equipment or system.

h. *Replace.* The act of substituting a serviceable like type part, subassembly, or module (component or assembly) for an unserviceable counterpart.

i. *Repair.* The application of maintenance service (inspect, test, service, adjust, align, calibrate, or replace) or other maintenance actions (welding, grinding, riveting, straightening, facing, remachining, or resurfacing) to restore serviceability to an item by correcting specific damage, fault, malfunction, or failure in a part, subassembly, module (component or assembly), end item, or system.

j. *Overhaul.* That maintenance effort (service/action) necessary to restore an item to a completely serviceable/operational condition as prescribed by maintenance standards (i.e., DMWR) in appropriate technical publications. Overhaul is normally the highest degree of maintenance performed by the Army. Overhaul does not normally return an item to like new condition.

k. *Rebuild.* Consists of those services/actions necessary for the restoration of unserviceable equipment to a like new condition in accordance with original manufacturing standards. Rebuild is the highest degree of materiel maintenance applied to Army equipment. The rebuild operation includes the act of returning to zero those age measurements (hours, miles, etc.) considered in classifying Army equipments/components.

#### **B-4. Column Entries.**

a. *Column 7, Group Number.* Column 1 lists group numbers, the purpose of which is to identify components, assemblies, subassemblies, and modules with the next higher assembly.

b. *Column 2, Component/Assembly.* Column 2 contains the noun names of components, assemblies, subassemblies, and modules for which maintenance is authorized.

c. *Column 3, Maintenance function.* Column 3 lists the functions to be performed on the item listed in Column 2. When items are listed without maintenance functions, it is solely for the purpose of having the group numbers in the MAC and RPSTL coincide.

d. *Column 4, Maintenance Category.* Column 4 specifies by the listing of a worktime figure in the appropriate subcolumn(s),

the lowest level of maintenance authorized to perform the function listed in Column 3. This figure represents the active time required to perform that maintenance function at the indicated category of maintenance. If the number or complexity of the tasks within the listed maintenance function vary at different maintenance categories, appropriate worktime figures will be shown for each category. The number of task-hours specified by the worktime figure represents the average time required to restore an item (assembly, subassembly, component, module, end item or system) to a serviceable condition under typical field operating conditions. This time includes preparation time, troubleshooting time, and quality assurance/quality control time in addition to the time required to perform the specific tasks identified for the maintenance functions authorized in the maintenance allocation chart. Subcolumns of Column 4 are as follows:

- C Operator/Crew
- O Organizational
- F Direct Support
- H General Support
- D Depot.

e. *Column 5, Tools and Equipment.* Column 5 specifies, by code, those common tool sets (not individual tools), and special tools, test, and support equipment required to perform the designated function.

f. *Column 6, Remarks.* Column 6 contains an alphabetic code which leads to the remark in Section IV, Remarks, which is pertinent to the item opposite the particular code.

**B-5. Tool and Test Equipment Requirements (Section III).**

a. *Tool or Test Equipment Reference Code.* The numbers in this column coincide with the numbers used in the tools and equipment column of the MAC. The numbers indicate the applicable tool or test equipment for the maintenance functions.

b. *Maintenance Category.* The codes in this column indicate the maintenance category allocated the tool or test equipment.

c. *Nomenclature.* This column lists the noun name and nomenclature of the tools and test equipment required to perform the maintenance functions.

d. *National/NATO Stock Number.* This column lists the National/NATO stock number of the specific tool or test equipment.

e. *Tool Number.* This column lists the manufacturer's part number of the tool followed by the Federal Supply Code for manufacturers (5-digit) in parentheses.

**B-6. Remarks (Section IV).**

a. *Reference Code.* This code refers to the appropriate item in Section II, Column 6.

b. *Remarks.* This column provides the required explanatory information necessary to clarify items appearing in Section II.

**SECTION II. MAINTENANCE ALLOCATION CHART  
FOR  
REGULATED DC POWER SUPPLY MODEL 6268B**

(1) Group Number	(2) Component Assembly	(3) Maintenance Functions	(4) Maintenance Category					(5) Tools and Equip.	(6) Remarks
			C	O	F	H	D		
00	POWER SUPPLY, HP 6268B	INSPECT						1,5	A B E
		TEST						1,2,5,7	
		TEST					1.0		
		ADJUST					0.5	1,2,5,7	
		CALIBRATE					0.8	1,2,5,7	
01	MAIN CIRCUIT BOARD A1	OVERHAUL					60.0	1,2,3, 4,5,6,7	C
		REBUILD					80.0	1,2,3, 4,5,6,7	
		REPAIR					1.5	1,2,3, 4,5,6,7	
02	INTERCONNECTION BOARD A3	REPAIR					0.5	1,2,3, 4,5,6,7	C
03	FRONT PANEL ASSEMBLY A5	CALIBRATE					0.2	1,5,7	D
		REPAIR					1.5	1,2,3, 4,5,6,7	C
04	HEAT SINK ASSEMBLY A4	REPAIR					1.5	1,2,3, 4,5,6,7	C
05	RFI FILTER ASSEMBLY A2	REPAIR					1.5	1,2,3, 4,5,6,7	C

**SECTION III. TOOL AND TEST EQUIPMENT REQUIREMENTS  
FOR  
REGULATED DC POWER SUPPLY MODEL 6268B**

<b>Tool or Test Equipment Ref Code</b>	<b>Maintenance Category</b>	<b>Nomenclature</b>	<b>National/NATO Stock Number</b>	<b>Tool Number</b>
1	O,D	DIGITAL MULTIMETER, AN/USM-451	6625-00-168-0585	
2	D	OSCILLOSCOPE, OS-261/U	6625-00-127-0079	
3	D	TOOL KIT, PRINTED CIRCUIT CARD REPAIR	3439-00-196-0703	
4	D	TOOL KIT, WIRE WRAP/ELECTRICAL CONNECTOR		
5	O,D	TOOL KIT, TK-105/G	5180-00-610-8177	
6	D	TOOL KIT, TK-100/G	5180-00-605-0079	
7	D	ACCESSORIES KIT, POWER SUPPLY REPAIR		

**SECTION IV. REMARKS  
FOR  
REGULATED DC POWER SUPPLY MODEL 6268B**

<b>Reference Code</b>	<b>Remarks</b>
A	VISUAL EXTERNAL
B	TEST IS TURN-ON CHECKOUT PROCEDURE
C	REPAIR BY MOUNTED COMPONENT REPLACEMENT
D	CALIBRATION IS PERFORMED FOR VOLTMETER AND AMMETER
E	PERFORMANCE TEST IS USED AS AN INSPECTION CHECK AND AFTER MAJOR REPAIRS. APPROPRIATE PORTIONS OF THIS TEST ARE APPLIED AS OPERATION CHECKS AFTER MINOR REPAIRS.



**APPENDIX C  
COMPONENTS OF END ITEM LIST**

---

**SECTION I. INTRODUCTION**

**C-1. Scope.** This appendix lists integral components of and basic issue items for the HP 6268B to help you inventory items required for safe and efficient operation.

**C-2. General.** This Components of End Item List is divided into the following sections:

a. Section II. Integral Components of the End Item.

These items, when assembled, comprise the HP 6268B and must accompany it whenever it is transferred or turned in. The illustrations will help you identify these items.

b. Section III. Basic Issue Items. These are the minimum essential items required to place the HP 6268B in operation, to operate it, and to perform emergency repair. Although shipped separately packed they must accompany the HP 6268B during operation and whenever it is transferred between accountable officers. The illustrations will assist you with hard-to-identify items. This manual is your authority to requisition replacement BII, based on TOE/MTOE authorization of the end item.

**C-3. Explanation of Columns.**

a. Illustration. This column is divided as follows:

(1) Figure Number. Indicates figure number of the illustration on which the item is shown.

(2) Item Number. The number used to identify item called out in the illustration.

b. National Stock Number. Indicates the National stock number assigned to the item and which will be used for requisitioning.

c. Part Number. Indicates the primary number used by the manufacturer, which controls the design and characteristics of the item by means of its engineering drawings, specifications, standards, and inspection requirements to identify an item or range of items.

d. Description. Indicates the Federal item name and, if required, a minimum description to identify the item.

e. Location. The physical location of each item listed is given in this column. The lists are designed to inventory all items in one area of the major item before moving on to an adjacent area.

f. Quantity Required (Qty Reqd). This column lists the quantity of each item required for a complete major item.

g. Quantity. This column is left blank for use during an inventory. Under the Rcv'd column, list the quantity you actually receive on your major item. The Date columns are for your use when you inventory the major item at a later date, such as for shipment to another site.

SECTION II. INTEGRAL COMPONENTS OF END ITEM

(1) ILLUSTRATION		(2)	(3)	(4)	(5)	(6)	(7)	(8) QUANTITY			
(a) FIGURE NO.	(b) ITEM NO.	NATIONAL STOCK NUMBER	PART NO.	DESCRIPTION	LOCATION	USABLE ON CODE	QTY REQD	RCV'D	DATE	DATE	DATE

C-1

1

Power Supply  
HP 6268B (28480)

1

TECHNICAL MANUAL, TM 11-6130-417-14

**Section III.  
BASIC ISSUE ITEMS**

(1) ILLUSTRATION		(2)	(3)	(4)	(5)	(6)	(7)	(8) QUANTITY			
(a) FIGURE NO.	(b) ITEM NO.	NATIONAL STOCK NUMBER	PART NO.	DESCRIPTION	LOCATION	USABLE ON CODE	QTY REQD	RCV'D	DATE	DATE	DATE
				NO BASIC ISSUE ITEMS							

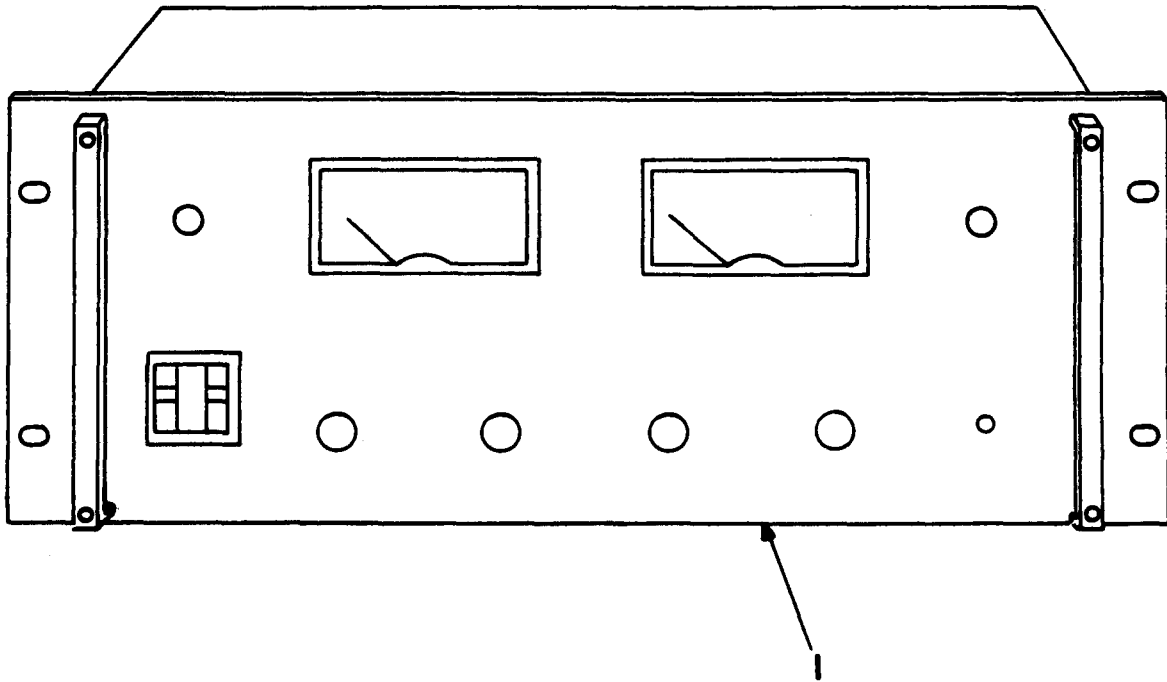

Figure C-1. Power Supply HP6268B.

APPENDIX D  
ADDITIONAL AUTHORIZATION LIST

---

SECTION I. INTRODUCTION

**D-1. Scope.** This appendix lists additional items you are authorized for the support of the HP 6268B.

These items are all authorized to you by CTA, MTOE, TDA, or JTA.

**D-2. General.** This list identifies items that do not have to accompany the HP 6268B and that do not to be turned in with it.

**D-3. Explanation of Listing.** National stock numbers, descriptions, and quantities are provided to help you identify and request the additional items you require to support this equipment.

Section II.  
ADDITIONAL AUTHORIZATION LIST

<b>(1)</b>  <b>NATIONAL STOCK NUMBER</b>	<b>(2)</b>  <b>DESCRIPTION</b>  <b>PART NUMBER &amp; FSCM                      USABLE ON CODE</b>	<b>(3)</b>  <b>U/M</b>	<b>(4)</b>  <b>QTY AUTH</b>
<p style="text-align: center;">NO ADDITIONAL AUTHORIZED ITEMS</p>			

**APPENDIX E**  
**EXPENDABLE SUPPLIES AND MATERIALS LIST**

---

**SECTION I. INTRODUCTION**

**E-1. Scope.** This appendix lists expendable supplies and materials you will need to operate and maintain the HP 6268B. These items are authorized to you by CTA 50-970, Expendable Items (Except Medical, Class V, Repair Parts, and Heraldic Items).

**E-2. Explanation of Columns.**

a. Column 1 - Item Number. This number is assigned to the entry in the listing and is referenced in the narrative instructions to identify the material (e.g., "Use cleaning compound, item 5, App. D").

b. Column 2 - Level. This column identifies the lowest level of maintenance that requires the listed item.

- C - Operator/Crew
- O - Organizational Maintenance
- F - Direct Support Maintenance
- H - General Support Maintenance

c. Column 3 - National Stock Number. This is the National stock number assigned to the item; use it to request or requisition the item.

d. Column 4 - Description. Indicates the Federal item name and, if required, a description to identify the item. The last line for each item indicates the part number followed by the Federal Supply Code for Manufacturer (FSCM) in parentheses, if applicable.

e. Column 5 - Unit of Measure (U/M). Indicates the measure used in performing the actual maintenance function. This measure is expressed by a two-character alphabetical abbreviation (e.g., ea, in, pr). If the unit of measure differs from the unit of issue, requisition the lowest unit of issue that will satisfy your requirements.

(1) ITEM NUMBER	(2) LEVEL	(3) NATIONAL STOCK NUMBER	(4) DESCRIPTION	(5) U/M
1	0	8305-267-3015	Cloth, cotton, cheesecloth	ROLL
2	0		Enamel,	QT
3	0	8010-582-5318	Primer, zinc chromate	QT
4	0		Sandpaper, Fine, No. 0000	SHT
5	0		Soft-bristle brush	EA
6	0	6810-00-292-9625	Trichlorotrifluoroethane OT620 (81349)	OZ



ALPHABETICAL INDEX

Subject	Paragraph		
<b>A</b>		<b>C</b>	
Accessory Equipment Available	1-19	Capacitance, Output	3-79
Adjustment and Calibration,		Charging, Battery	3-87
Ammeter	5-71	Check,	
Constant-Current Programming	5-89	Electrical	2-5
Constant-Voltage Programming	5-79	Mechanical	2-3
Crowbar Trip Voltage	5-104	Circuit,	
Disabling the Crowbar	5-108	Detailed Circuit Analysis	5-16
Load Transient Recovery Time	5-98	Meter	4-66
Maximum Crowbar Trip Voltage	5-106	Overvoltage Limit	4-27
Meter Zero	5-73	Preregulator Control Circuit	4-17
Overvoltage Trip Point	3-12	Short Circuit Protection	4-31
Preregulator Tracking	5-102	Turn-On Control	4-58
Ripple Balance	5-100	Voltage Clamp	4-45
Additional Protection Features	4-70	Comparator,	
Ammeter Accuracy	5-41	Constant Current	4-40
Amplifiers,		Constant Voltage	4-33
Error	4-51	Connecting the Load	3-15
Mixer	4-49	Constant Current,	
Auto-Parallel,		Comparator	4-40
Operation	3-51	Operation	3-10
Overvoltage Protection	5-54	Output, Resistance Input	5-45
Remote Programming	3-56	Output, Voltage Input (fixed gain)	3-47
Remote Sensing	3-55	Output, Voltage Input (variable gain),	3-48
Setting the Voltage and Current Controls	3-53	Programming Calibration	5-89
Auto-Series,		Tests	5-38
Determining the Value for Rx	3-60	Constant Voltage,	
Operation	3-57	Comparator	4-33
Overvoltage Protection	3-64	Operation	5-3
Remote Programming	3-66	Output, Resistance Input	3-39
Remote Sensing	3-65	Output, Voltage Input (unit gain)	3-41
Setting the Current Controls	3-63	Output, Voltage Input (variable gain)	3-42
Setting the Voltage Controls	3-62	Programming Calibration	5-79
Auto-Tracking,		Tests	5-7
Determining the Value for Rx	3-69	Control Circuit, Preregulator	4-17
Operation	3-67	Controls, Setting the Voltage and Current	
Overvoltage Protection	3-72	Auto Series	3-62, 63
Remote Programming	3-75	Auto-Tracking	3-71
Remote Sensing	3-74	Auto-Parallel	3-53
Setting the Voltage and Current Controls	3-71	Crowbar,	
<b>B</b>		Disabling the	5-108
Battery,		Overvoltage Protection	4-52
Charging	3-87	Trip Voltage Adjustment	5-104
Constant Current Discharge	3-94	Current,	
Discharging	3-91	Output	5-41
Taper Charge	3-90	Reverse Loading	3-85
		Conversion, Input Line Voltage or Frequency	2-17

Subject	Paragraph	Subject	Paragraph
Converting a Standard Instrument to, 50 Hz Operation	2-28		
115-Volt Operation (Model 6260B)	2-26		
115-Volt Operation (Models 6259B, 6261 B and 6268B)	2-24		
208-Volt Operation (Models 6260B and 6269B)	2-22		
208-Volt Operation (Models 6259B, 6261B and 6268B)	2-20		
Cooling, Location and	2-9		
		<b>L</b>	
		Leads,	
		Inductance	3-33
		Load	3-30
		Sensing	3-31, 32
		Load,	
		Connecting the	3-15
		Effect (load regulation)	5-11, 5-42
		Operation with No Load	3-20
		Transient Recovery Time	5-27
		Loading,	
		Pulse	3-77
		Reverse Current	3-85
		Location and Cooling	2-9
		<b>M</b>	
		Main Circuit Board Removal	5-62
		Main Filter Capacitor Bank Removal	5-64
		Maintenance Introduction	5-1
		Maximum Crowbar Trip Voltage Adjustment	5-106
		Measurement,	
		Procedures	5-30
		Techniques	5-28
		Mechanical Check	2-3
		Meter Circuit	4-66
		Meter Zero Adjustment	5-73
		Mixer Amplifier	4-48
		Mode(s),	
		Normal Operating	3-6
		Operating	3-3
		Optional Operating	3-24
		Mounting, Rack	2-13
		<b>N</b>	
		Noise Spike Measurements	5-24
		<b>O</b>	
		Operating,	
		Instructions	3-1
		Modes	3-3
		Normal Mode	3-6
		Optional Modes	3-24
		Special Considerations	3-76
		Operation,	
		Auto-Parallel,	3-51
		Auto-Parallel with Remote Programming	3-56
		Auto-Parallel with Remote Sensing	3-55
		Auto-Series,	3-57
		Auto-Series with Remote Programming	3-66
		Auto-Series with Remote Sensing	3-65
		Auto-Tracking,	3-67
<b>D</b>			
Description, General	1-1		
Detailed Circuit Analysis	4-16		
Determining the Value for Rx, Auto-Series	3-60		
Auto-Tracking	3-69		
Diagram, Outline	2-11		
Overall Block	4-1		
Disabling the Crowbar	5-108		
Disassembly Procedures	5-60		
Discharging, Battery	3-91		
Drift (stability)	5-35		
Driver Series Regulator and,	4-29		
		<b>E</b>	
Electrical Check	2-5		
Equipment, Required Test	5-3		
Equipment Supplied	1-17		
Error Amplifier	4-51		
		<b>F</b>	
Filter Assembly Removal, Main Capacitor Bank	5-64		
RFI	5-65		
Front Panel Removal	5-63		
		<b>H</b>	
Heat Sink, Disassembly	5-67		
Removal	5-66		
		<b>I</b>	
Initial Inspection	2-1		
Input Line Voltage or Frequency Conversion	2-17		
Input Power, Connections	2-30		
Requirements	2-15		
Installation Data	2-7		
Instrument/Manual Identification	1-12		
Interconnection Circuit Board Removal	5-68		
Introduction, Maintenance	5-1		

Subject	Paragraph	Subject	Paragraph
Auto-Tracking with Remote Programming	3-75	Remote,	
Auto-Tracking with Remote Sensing	3-74	Programming	3-34
With No Load	3-20	Programming, Auto-Parallel	3-56
Options	1-10	Programming, Auto Series	3-66
Outline Diagram	2-11	Programming, Auto-Tracking	3-75
Output Capacitance	3-79	Sensing, Auto-Parallel	3-55
Overall,		Sensing, Auto-Series	3-65
Block Diagram Discussion	4-1	Sensing, Auto-Tracking	3-74
Troubleshooting Procedures	5-54	Voltage Sensing	3-27
Beyond Rated Output	3-22	Removal,	
Overvoltage,		Front Panel	5-63
Limit Circuit	4-27	Heat Sink	5-66
Protection Crowbar	4-52	Interconnection Circuit Board	5-68
Protection In Auto-Series	3-64	Main Circuit Board	5-62
Protection In Auto-Parallel	3-54	Main Filter Capacitor Bank	5-64
Protection In Auto-Tracking	3-72	RFI Filter Assembly	5-65
Trip Point Adjustment	3-12	Removal, Complete, for Overhaul and Repair	
		B Bus Bars (+B, -B)	5-122
<b>P</b>		Capacitor Bank Filter, Main	5-120
Parallel Operation, Auto	3-51	Fan B2	5-116
With Remote Programming	3-56	Front Panel A5	5-130
With Remote Sensing	3-55	Disassembly	5-132
PARD (Ripple and Noise)	5-15	Heat Sink A4	5-114
Performance Test	5-5	Interconnection Board A3	5-112
Power,		Mounts, Standoff, A2RFI Assembly	5-124
Input Connections	2-30	Rear Panel	5-126
Input Requirements	2-15	RFI Assembly A2	5-65
Preregulator,		Terminal Board TB1, Input Power	5-126
Control Circuit	4-17	Transformer T1	5-116
Tracking Adjustment	5-102	Repackaging for Shipment	2-32
Procedure,		Repair and Replacement	5-69
Disassembly	5-60	Requirements, Input Power	2-15
Measurement:	5-30	Reverse,	
Overall Troubleshooting	5-54	Current Loading	3-85
Turn-On Checkout	3-1	Voltage Protection	3-82
Programming,		RFI Filter Assembly Removal	5-65
Constant-Current Calibration	5-69	Ripple,	
Constant-Voltage Calibration	5-79	Balance Adjustment	5-100
Remote	3-34	PARD (Ripple and Noise)	5-15
Remote, Auto-Parallel	3-56	Measurement Procedure	5-23
Remote, Auto-Series	3-66	Measurement Techniques	5-17
Remote, Auto-Tracking	3-75	Rx, Determining the Value for	
Protection,		Auto-Series	3-60
Additional Features	4-70	Auto-Tracking	3-69
Crowbar	4-52		
Reverse Voltage	3-62	<b>S</b>	
Short-Circuit	4-31	Sensing, Remote Voltage	3-27
Pulse Loading	3-77	Series,	
		Regulator and Driver	4-29
<b>R</b>		Operation, Auto-	3-57
Rack Mounting	2-13	Setting the Voltage and Current Controls,	
Reference Regulator	4-61	Auto-Series	3-62, 63
Regulator and Driver, Series	4-29	Auto-Tracking	3-71
		Auto-Parallel	3-53

Subject	Paragraph	Subject	Paragraph
Shipment, Repackaging for	2-32	Maximum Crowbar	5-106
Short Circuit Protection	4-31	Troubleshooting	
Source Effect (Line Regulation)	5-13, 44	Overall Procedures	5-54
Special Operating Considerations	3-76	Turn-On Control Circuit	4-58
Specifications	1-8	Voltage, Constant	
		Comparator	4-33
<b>T</b>		Operation	3-8
Temperature Coefficient	5-31	Programming Calibration	5-79
Test Equipment Required	5-3	Tests	5-7
Test(s),		Voltage,	
Constant-Current	5-38	Clamp Circuit	4-45
Constant-Voltage	5-7	Crowbar Trip Adjustment	5-104
Performance	5-5	Maximum Crowbar Trip	5-106
Tracking,		Output	5-10
Operation, Auto-	3-67	Sensing, Remote	3-27
Preregulator Tracking Adjustment	5-102	Protection, Reverse	3-82
Trip Point Adjustment, Overvoltage	3-12	Voltmeter,	
Trip Voltage Adjustment,		Accuracy	5-10
Crowbar	5-104		5-75

RECOMMENDED CHANGES TO EQUIPMENT TECHNICAL PUBLICATIONS



THEN... JOT DOWN THE DOPE ABOUT IT ON THIS FORM. CAREFULLY TEAR IT OUT. FOLD IT AND DROP IT IN THE MAIL!

SOMETHING WRONG WITH THIS PUBLICATION?

FROM: (PRINT YOUR UNIT'S COMPLETE ADDRESS)  
 Commander  
 Stateside Army Depot  
 ATTN: AMSTA-US  
 Stateside, N.J. 07703

DATE SENT  
 4 April 1978

PUBLICATION NUMBER TM 11-5840-340-14&P	PUBLICATION DATE 23 Jan 74	PUBLICATION TITLE Radar Set AN/PRC-76
---	-------------------------------	--

BE EXACT... PIN-POINT WHERE IT IS				IN THIS SPACE TELL WHAT IS WRONG AND WHAT SHOULD BE DONE ABOUT IT:
PAGE NO	PARA-GRAPH	FIGURE NO	TABLE NO	
2-25	2-28			<p>Recommend that the installation antenna alignment procedure be changed throughout to specify a 2° IFF antenna lag rather than 1°.</p> <p>REASON: Experience has shown that with only a 1° lag, the antenna servo system is too sensitive to wind gusting in excess of 25 knots, and has a tendency to rapidly accelerate and decelerate as it hunts, causing strain to the drive train. Hunting is minimized by adjusting the lag to 2° without degradation of operation.</p>
3-10	3-3		3-1	<p>Item 5, Function column Change "2 db" to "3db."</p> <p>REASON: The adjustment procedure the TRANS POWER FAULT indicator calls for a 3 db (500 watts) adjustment to light the TRANS POWER FAULT indicator.</p>
5-6	5-8			<p>Add new step f.1 to read, "Replace cover plate removed in step e.1, above."</p> <p>REASON: To replace the cover plate.</p>
E-5				<p>For item 2, change the NSN to read: 5835-00-134-9186.</p> <p>REASON: Accuracy.</p>
E-8		E-3		<p>Identify the cover on the junction box (item no. 5).</p> <p>REASON: It is a separate item and is not called out on figure 19.</p>
E-9				<p>Add the cover of the junction box as an item in the listing for figure 19.</p> <p>REASON: Same as above.</p>

TEAR ALONG PERFORATED LINE

PRINTED NAME, GRADE OR TITLE, AND TELEPHONE NUMBER  
 SSG I. M. DeSpirito 999-1776

SIGN HERE



RECOMMENDED CHANGES TO EQUIPMENT TECHNICAL PUBLICATIONS



THEN...JOT DOWN THE DOPE ABOUT IT ON THIS FORM. CAREFULLY TEAR IT OUT, FOLD IT AND DROP IT IN THE MAIL.

**SOMETHING WRONG WITH THIS PUBLICATION?**

FROM: (PRINT YOUR UNIT'S COMPLETE ADDRESS)

---

DATE SENT

PUBLICATION NUMBER TM 11-6130-417-14	PUBLICATION DATE 25 FEB 1983	PUBLICATION TITLE Opr, Org, DS & GS Maint Manual Power Supply PP-7833/U
---	---------------------------------	---

BE EXACT PIN-POINT WHERE IT IS				IN THIS SPACE TELL WHAT IS WRONG AND WHAT SHOULD BE DONE ABOUT IT:
PAGE NO.	PARA-GRAPH	FIGURE NO.	TABLE NO.	

TEAR ALONG PERFORATED LINE

PRINTED NAME GRADE OR TITLE AND TELEPHONE NUMBER	SIGN HERE
--	-----------

FILL IN YOUR  
UNIT'S ADDRESS

FOLD BACK

DEPARTMENT OF THE ARMY

\_\_\_\_\_  
\_\_\_\_\_

OFFICIAL BUSINESS  
PENALTY FOR PRIVATE USE \$300

POSTAGE AND FEES PAID  
DEPARTMENT OF THE ARMY  
DOD 314



TEAR ALONG PERFORATED LINE

Commander  
US Army Communications-Electronics Command  
and Fort Monmouth  
ATTN: DRSEL-ME-MP  
Fort Monmouth, New Jersey 07703



RECOMMENDED CHANGES TO EQUIPMENT TECHNICAL PUBLICATIONS



THEN...JOT DOWN THE DOPE ABOUT IT ON THIS FORM. CAREFULLY TEAR IT OUT, FOLD IT AND DROP IT IN THE MAIL.

SOMETHING WRONG WITH THIS PUBLICATION?

FROM: (PRINT YOUR UNIT'S COMPLETE ADDRESS)

DATE SENT

PUBLICATION NUMBER  
TM 11-6130-417-14

PUBLICATION DATE  
25 FEB 1982

PUBLICATION TITLE  
Opr, Org, DS & GS Maint Manual  
Power Supply PP-7833/U

BE EXACT PIN-POINT WHERE IT IS

PAGE NO.	PARA-GRAPH	FIGURE NO.	TABLE NO.

IN THIS SPACE TELL WHAT IS WRONG AND WHAT SHOULD BE DONE ABOUT IT:

*(This area is currently blank for user input.)*

TEAR ALONG PERFORATED LINE

PRINTED NAME GRADE OR TITLE AND TELEPHONE NUMBER

SIGN HERE

FILL IN YOUR  
UNIT'S ADDRESS

FOLD BACK

DEPARTMENT OF THE ARMY

\_\_\_\_\_  
\_\_\_\_\_

OFFICIAL BUSINESS  
PENALTY FOR PRIVATE USE \$300

POSTAGE AND FEES PAID  
DEPARTMENT OF THE ARMY  
DOD 314



TEAR ALONG PERFORATED LINE

Commander  
US Army Communications-Electronics Command  
and Fort Monmouth  
ATTN: DRSEL-ME-MP  
Fort Monmouth, New Jersey 07703

RECOMMENDED CHANGES TO EQUIPMENT TECHNICAL PUBLICATIONS



THEN...JOT DOWN THE DOPE ABOUT IT ON THIS FORM. CAREFULLY TEAR IT OUT, FOLD IT AND DROP IT IN THE MAIL.

SOMETHING WRONG WITH THIS PUBLICATION?

FROM: (PRINT YOUR UNIT'S COMPLETE ADDRESS)

DATE SENT

PUBLICATION NUMBER  
TM 11-6130-417-14

PUBLICATION DATE  
25 FEB 1982

PUBLICATION TITLE  
Opr, Org,DS & GS Maint Manual  
Power Supply PP-7833/U

BE EXACT PIN-POINT WHERE IT IS

PAGE NO.	PARA-GRAPH	FIGURE NO.	TABLE NO.
----------	------------	------------	-----------

IN THIS SPACE TELL WHAT IS WRONG AND WHAT SHOULD BE DONE ABOUT IT:

TEAR ALONG PERFORATED LINE

PRINTED NAME GRADE OR TITLE AND TELEPHONE NUMBER

SIGN HERE

FILL IN YOUR  
UNIT'S ADDRESS



FOLD BACK

DEPARTMENT OF THE ARMY

\_\_\_\_\_  
\_\_\_\_\_

OFFICIAL BUSINESS  
PENALTY FOR PRIVATE USE \$300

POSTAGE AND FEES PAID  
DEPARTMENT OF THE ARMY  
DOD 314



TEAR ALONG PERFORATED LINE

Commander  
US Army Communications-Electronics Command  
and Fort Monmouth  
ATTN: DRSEL-ME-MP  
Fort Monmouth, New Jersey 07703

**By Order of the Secretaries of the Army, the Navy, and the Air Force**

**E. C. MEYER**  
*General, United States Army*  
*Chief of Staff*

**Official:**  
**ROBERT M. JOYCE**  
*Major General United States Army*  
*The Adjutant General*

**G. B. SHICK**  
*Rear Admiral United States Navy*  
*Commander, Naval Electronic*  
*Systems Command*

**CHARLES A. GABRIEL, General USAF**  
*Chief of Staff*

**Official:**  
**JAMES P. MULLINS**  
*General, USAF, Commander, Air Force*  
*Logistics Command*

**DISTRIBUTION:**

**To be distributed in accordance with Special List.**

\* U.S. GOVERNMENT PRINTING OFFICE : 1989 0 - 242-451 (1553)





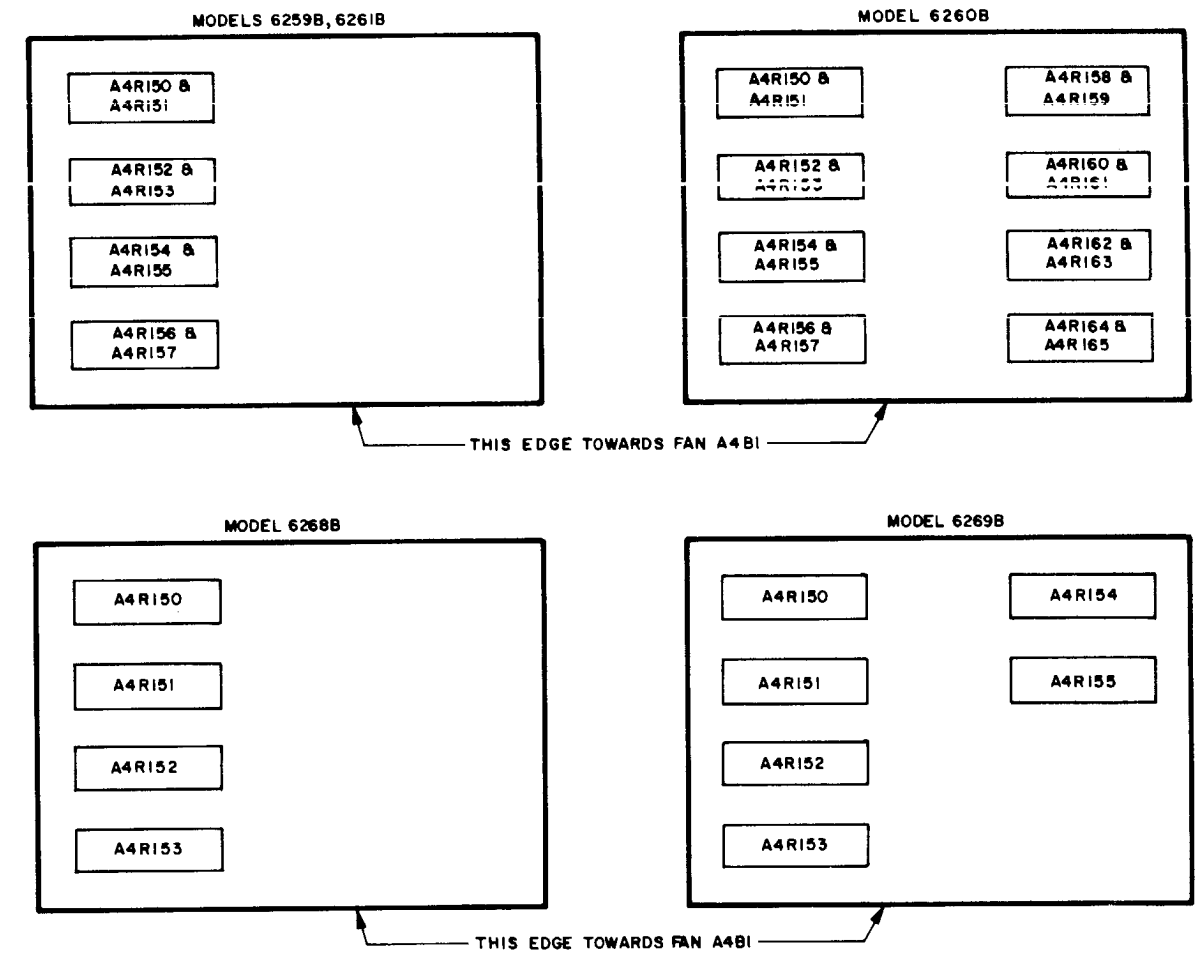

Figure FO-2. A4 Heatsink Assembly Emitter Resistor Board Component Locations



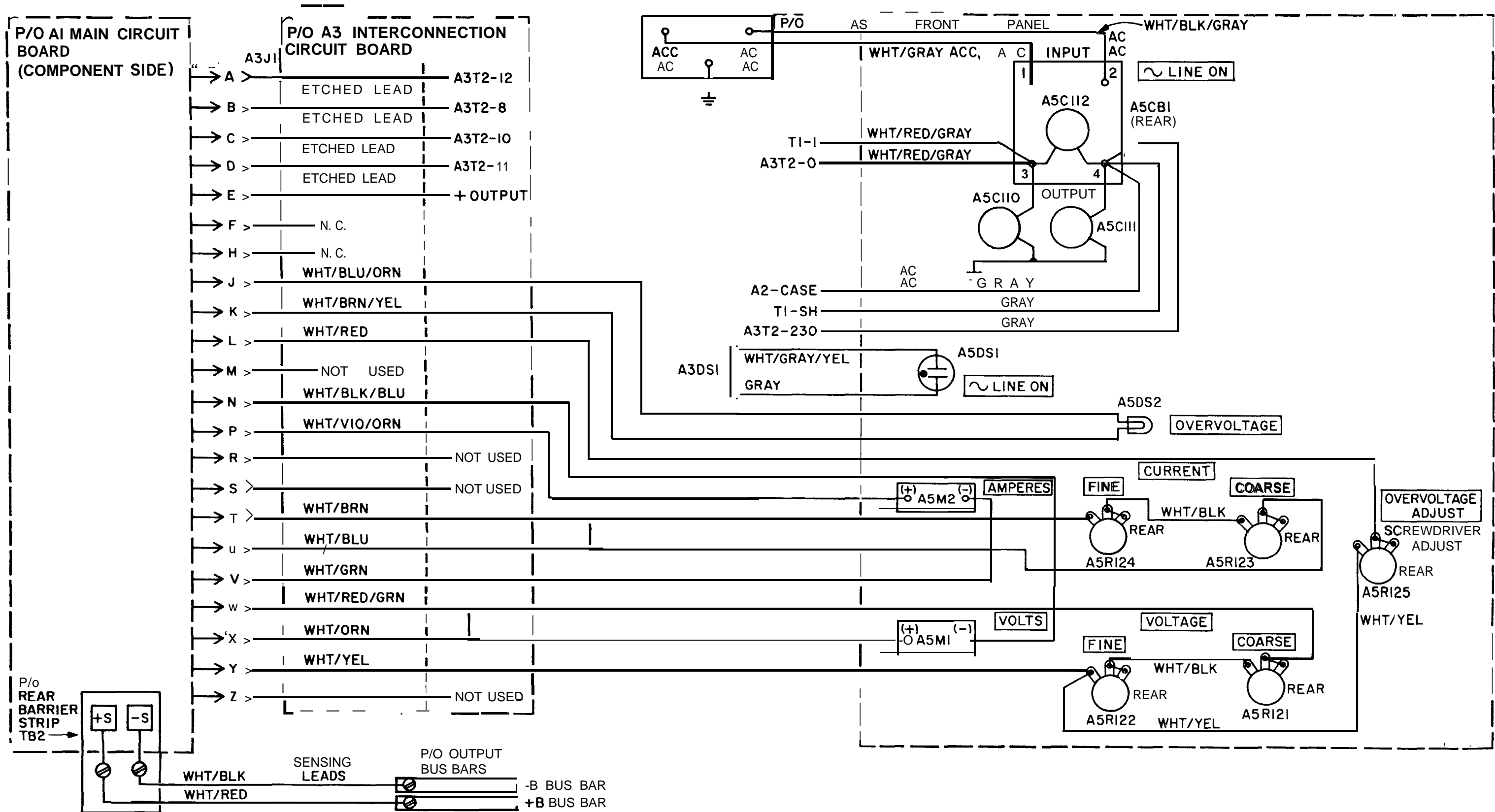

Figure FO-3. Interconnection Diagram (Sheet 1 of 3)

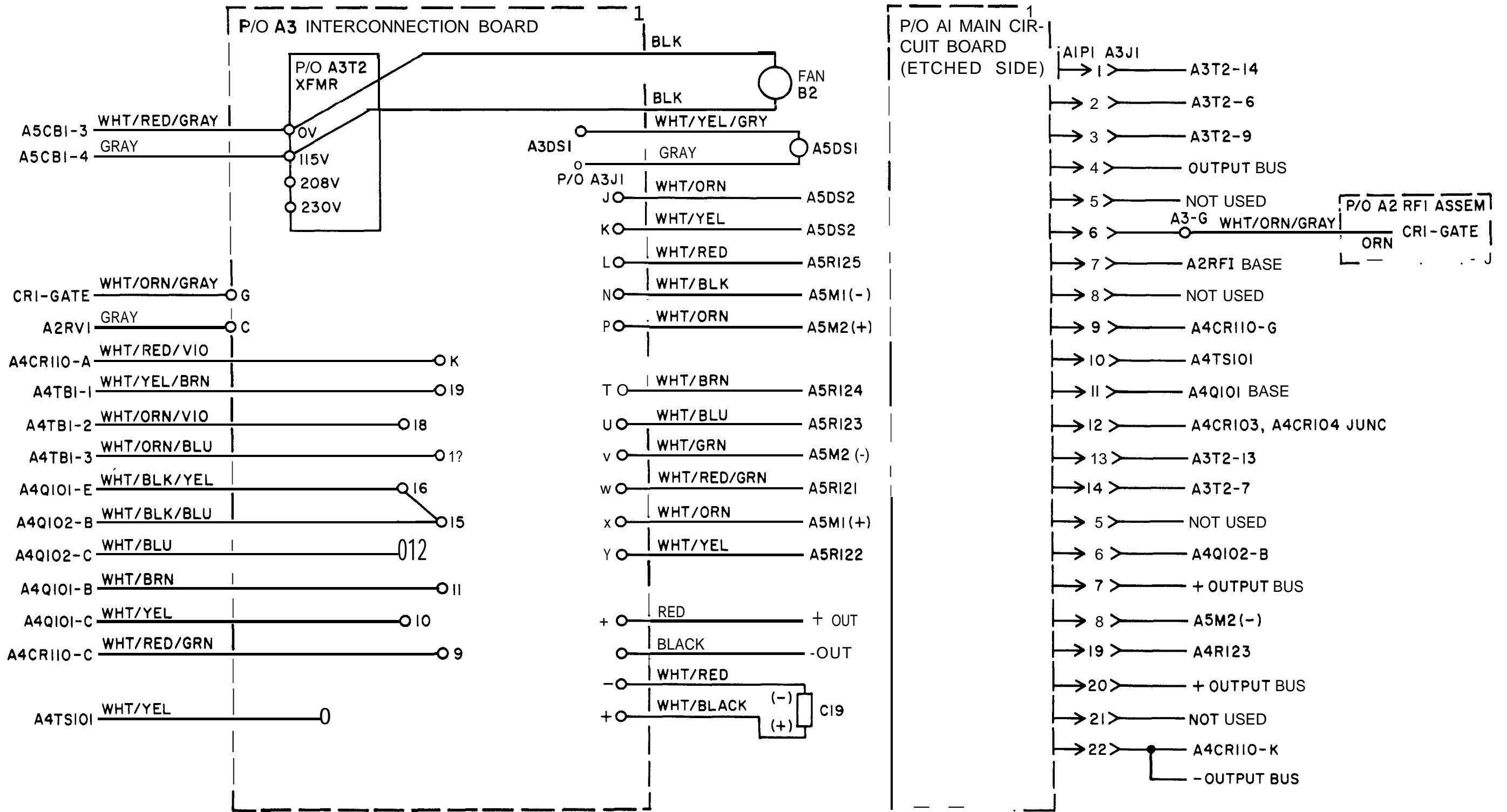

Figure FO-3. Interconnection Diagram (Sheet 2 of 3)

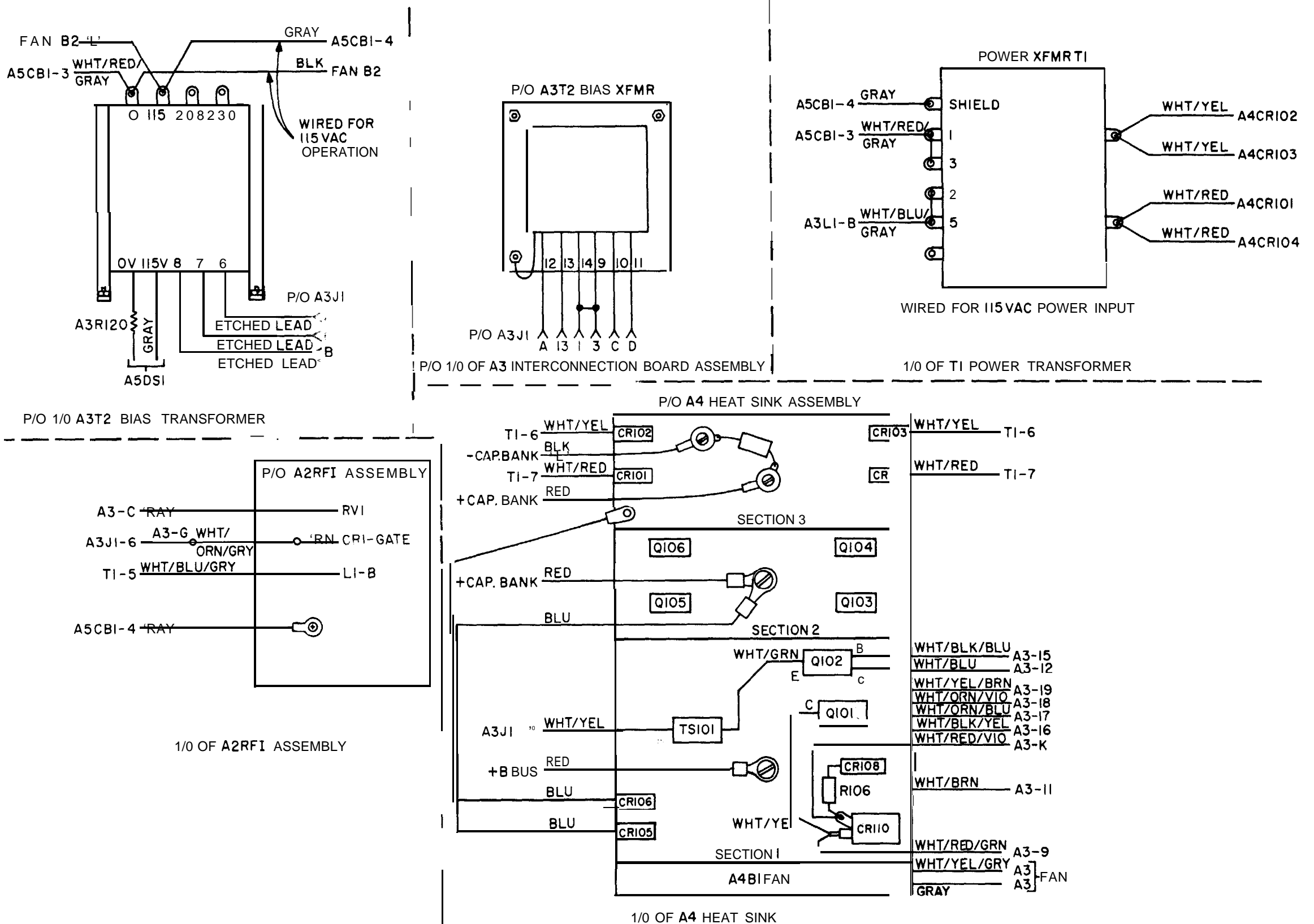

Figure FO-3. Interconnection Diagram (Sheet 3 of 3)





This fine document...

Was brought to you by me:



## [Liberated Manuals -- free army and government manuals](#)

Why do I do it? I am tired of sleazy CD-ROM sellers, who take publicly available information, slap “watermarks” and other junk on it, and sell it. Those masters of search engine manipulation make sure that their sites that sell free information, come up first in search engines. They did not create it... They did not even scan it... Why should they get your money? Why are not letting you give those free manuals to your friends?

I am setting this document FREE. This document was made by the US Government and is NOT protected by Copyright. Feel free to share, republish, sell and so on.

I am not asking you for donations, fees or handouts. If you can, please provide a link to [liberatedmanuals.com](http://liberatedmanuals.com), so that free manuals come up first in search engines:

<A HREF=<http://www.liberatedmanuals.com/>>Free Military and Government Manuals</A>

- Sincerely  
Igor Chudov  
<http://igor.chudov.com/>
- [Chicago Machinery Movers](#)