

**Agilent
85132E/F
3.5 mm to 7 mm
Test Port
Return Cables**

**Operating and Service
Manual**



85132-90010



Agilent Technologies

Notices

© Agilent Technologies, Inc. 1987, 2008, 2013

No part of this manual may be reproduced in any form or by any means (including electronic storage and retrieval or translation into a foreign language) without prior agreement and written consent from Agilent Technologies, Inc. as governed by United States and international copyright laws.

Manual Part Number

85132-90010

Edition

October 2013

Supersedes: February 2008

Agilent Technologies, Inc.
5301 Stevens Creek Blvd
Santa Clara, CA 95051

Warranty

The material contained in this document is provided “as is,” and is subject to being changed, without notice, in future editions. Further, to the maximum extent permitted by applicable law, Agilent disclaims all warranties, either express or implied, with regard to this manual and any information contained herein, including but not limited to the implied warranties of merchantability and fitness for a particular purpose. Agilent shall not be liable for errors or for incidental or consequential damages in connection with the furnishing, use, or performance of this document or of any information contained herein. Should Agilent and the user have a separate written agreement with warranty terms covering the material in this document that conflict with these terms, the warranty terms in the separate agreement shall control.

Technology Licenses

The hardware and/or software described in this document are furnished under a license and may be used or copied only in accordance with the terms of such license.

Restricted Rights Legend

If software is for use in the performance of a U.S. Government prime contract or sub-contract, Software is delivered and

licensed as “Commercial computer software” as defined in DFAR 252.227-7014 (June 1995), or as a “commercial item” as defined in FAR 2.101(a) or as “Restricted computer software” as defined in FAR 52.227-19 (June 1987) or any equivalent agency regulation or contract clause. Use, duplication or disclosure of Software is subject to Agilent Technologies’ standard commercial license terms, and non-DOD Departments and Agencies of the U.S. Government will receive no greater than Restricted Rights as defined in FAR 52.227-19(c)(1-2) (June 1987). U.S. Government users will receive no greater than Limited Rights as defined in FAR 52.227-14 (June 1987) or DFAR 252.227-7015 (b)(2) (November 1995), as applicable in any technical data.

Safety Notices

CAUTION

A **CAUTION** notice denotes a hazard. It calls attention to an operating procedure, practice, or the like that, if not correctly performed or adhered to, could result in damage to the product or loss of important data. Do not proceed beyond a **CAUTION** notice until the indicated conditions are fully understood and met.

WARNING

A **WARNING** notice denotes a hazard. It calls attention to an operating procedure, practice, or the like that, if not correctly performed or adhered to, could result in personal injury or death. Do not proceed beyond a **WARNING** notice until the indicated conditions are fully understood and met.

85132E/F Return Cables

General Information

To obtain optimum performance from this adapter kit, observe these simple precautions:

- Make connections carefully to avoid misalignment and connector damage, which will result in inaccurate measurements.
- Keep the connectors free of dirt and any particles.
- When you clean the connectors, try using compressed air first. Do not use abrasives. With a clean foam swab, apply only isopropyl alcohol.
- For more information, refer to the *Connector Care for RF and Microwave Coaxial Connectors* document. It can be viewed online by searching for part number 08510-90064 at www.agilent.com.

Description

The 85132E and 85132F differ from one another mainly in length and insertion loss specifications. Both are test port return cables designed specifically for use with 7 mm calibration and verification kits and test sets with NMD-3.5 mm ports as part of a network analyzer system. The 85132E consists of a single, 97.2 cm (38.25 inches) long cable with a 7 mm connector on the DUT end and an NMD-3.5 mm (f) connector on the test set end. The 85132E is used primarily with Reflection/Transmission test sets. The 85132F consists of two identical cables that are each 62.9 cm (24.75 inches) long and is used primarily with full S-parameter test sets. The cables in the 85132F cable set are also available individually as Agilent part number 85132-60004. Any of the two individual cables can be used to make a set.

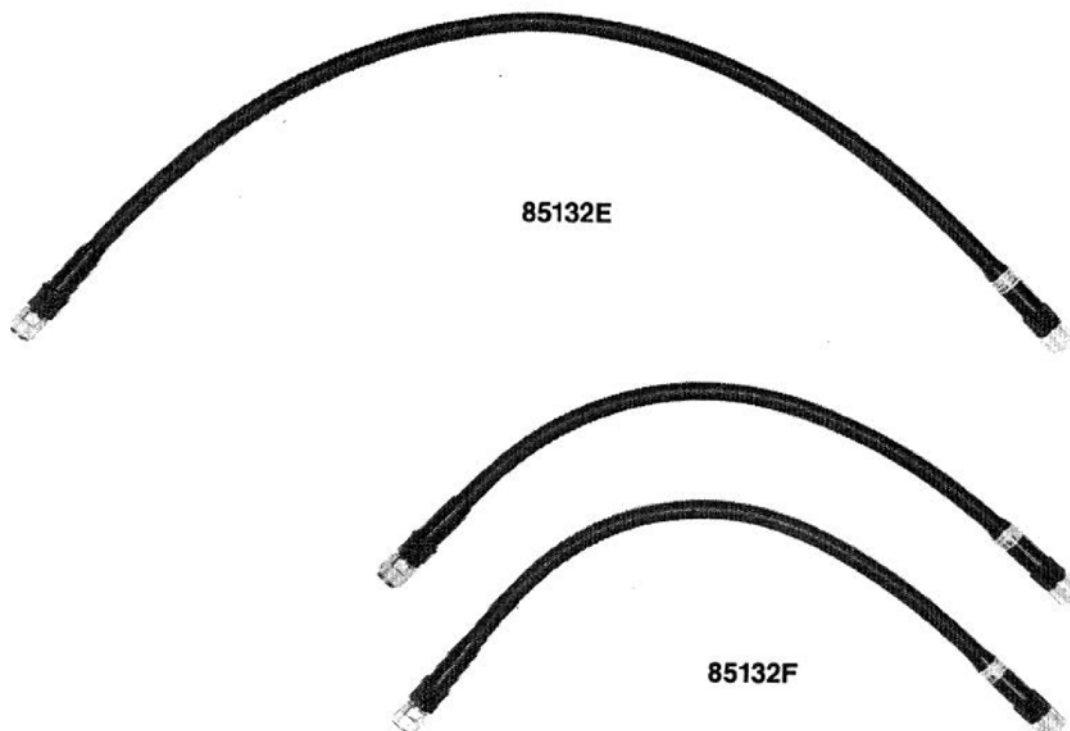

Specifications

Agilent Technologies guarantees that the performance of your cables will equal or exceed the following specifications, at frequencies <18 GHz:

SWR	≤1.3 (17.7 dB return loss)	
Insertion Loss (in dB)	≤[0.35√f + 0.3]	85132E
	≤[0.25√f + 0.2]	85132F

where f is in GHz

Recession of center conductor shoulder behind outer conductor mating plane.

NMD-3.5 mm (f) connector 0.005 to 0.056 mm (0.0002 to 0.0022 inch)

7 mm connector with collet removed 0.005 to 0.021 mm (0.0002 to 0.0008 inch)

Protrusion of 7 mm center pin with collet in place 0.05 to 0.25 mm (0.002 to 0.010 inch)

Supplemental Performance Data

The following data gives further information about the typical performance of 85132E/F cables.

Magnitude stability (dB) and Phase stability (degrees) ≤0.22 dB change, 85132E
 ≤0.12 dB change, 85132F

with a 90 degree, 3 inch bend radius ≤0.16 (f)^a + 0.8, 85132E
 ≤0.13 (f)^a + 0.5, 85132F

a. (f) = frequency in GHz.

Electrical length of the 85132E cable is approximately 1.150 m and it is approximately 0.74 m for the 85132F.

Performance Tests

Use a network analyzer to perform the following tests upon your cables as soon as you receive them. Periodically repeat the tests to determine if the performance is still satisfactory or if the cables need to be replaced.

Figure 1 Return Loss Setup

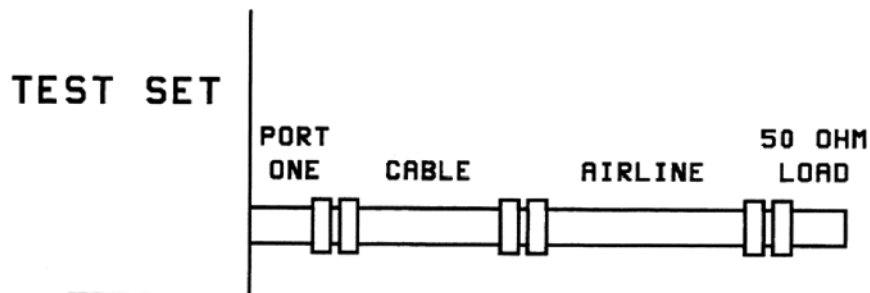

85132_010_002

Return loss is measured by connecting a 50 ohm fixed load termination through a 10 cm airline to the test cable, then attaching the cable to port one of the test set (see [Figure 1](#)).

The effects of an imperfect load may be gated out using the network analyzer time domain option.

NOTE Refer to your network analyzer's Help system for specific instructions on using the functions mentioned in the return loss test below.

1. Preset the analyzer.
2. Set a stimulus start frequency of the analyzer's lowest frequency.
3. Set a stimulus stop frequency of 18 GHz.
4. Set an IF bandwidth of 100 Hz.
5. Perform, and then save, a 3.5 mm 1-port S_{11} calibration.
6. With correction turned on, select the time domain mode.
7. Set a stimulus start time for the sweep to -0.05 nano-seconds.
8. Set a stimulus stop time for the sweep to 6.5 nano-seconds for the 85132F or 9.5 nano-seconds for the 85132E.
9. Select the gating function and gate-out everything but the cable. See [Figure 2](#).
10. Select the analyzer's frequency domain mode.
11. Use the markers to read the return loss value.

Figure 2 Analyzer Trace Showing Location of Gates and Airline

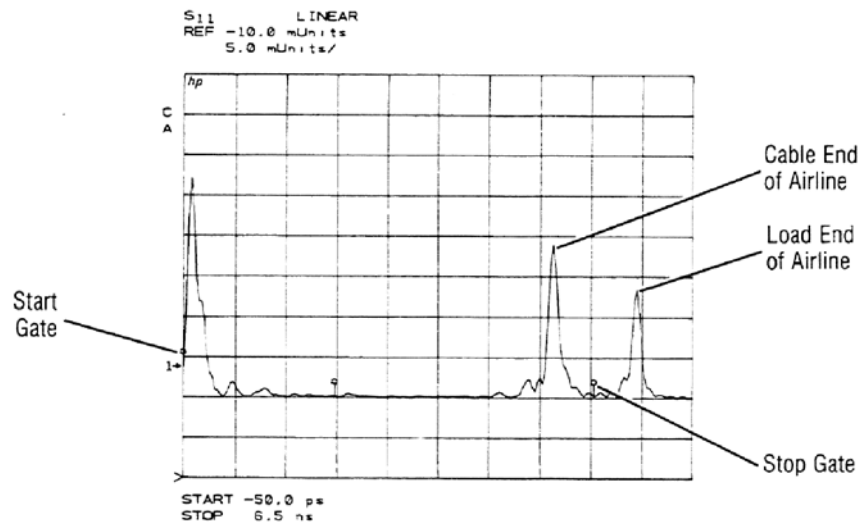

85132_010_003

Insertion loss is measured by terminating the cable with a short and then measuring return loss. Measure with the 1-port S_{11} calibration, made in the previous procedure, turned on. The values shown on the CRT represent an out-and-back path for the signal, which is twice the insertion loss for the cable. Therefore, it is

necessary to divide your worst case insertion loss by 2 before comparing it to the specifications in the beginning of this document (see [Figure 3](#)).

Figure 3 Insertion Loss Setup

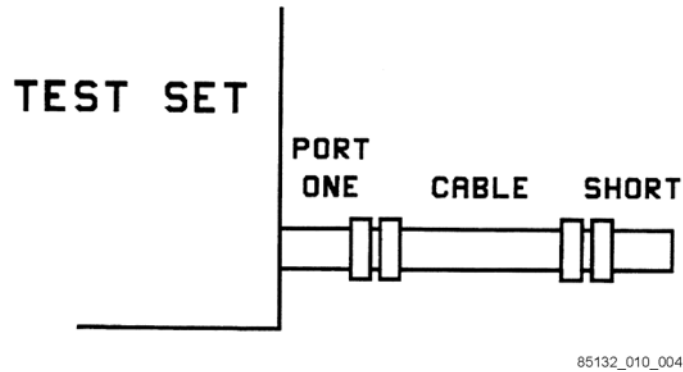

Replaceable Parts

The following items are replaceable on the 85132E/F cables:.

Item	Part Number
Six slot collets	85050-20001
A single 85132F cable	85132-60004

Equipment and Supplies

The following equipment and supplies are required for the maintenance and use of, but are not supplied with, your 85132E/F cables.

Item	Part Number
7 mm gage kit (part of 85050B calibration kits)	85050-80012
50 ohm fixed load termination (part of 85050B calibration kits)	85050-60006
10 cm airline (part of 85051B verification kits)	85051-60007
Short (part of 85050B calibration kits)	85050-80007
Torque wrench, 3/4", 136 N-cm (12 in-lb) (part of the 85050B calibration kits)	8710-1766
Extractor tool (used to remove the collets)	5060-0370
Document: <i>Connector Care for RF and Microwave Coaxial Connectors</i>	08510-90064
Spanner wrench	08513-20014

Visual Inspection

Visual inspection and, if necessary, cleaning should be done every time a connection is made. Metal particles from the connector threads may fall into the connector when it is disconnected. One connection made with a dirty or damaged connector can damage both connectors beyond repair.

Magnification is helpful when inspecting connectors, but it is not required and may actually be misleading. Defects and damage that cannot be seen without magnification generally have no effect on electrical or mechanical performance. Magnification is of great use in analyzing the nature and cause of damage and in cleaning connectors, but it is not required for inspection.

Look for Obvious Defects and Damage First

Examine the connectors first for obvious defects and damage: badly worn plating on the connector interface, deformed threads, or bent, broken, or misaligned center conductors. Connector nuts should move smoothly and be free of burrs, loose metal particles, and rough spots.

What Causes Connector Wear?

Connector wear is caused by connecting and disconnecting the devices. The more use a connector gets, the faster it wears and degrades. The wear is greatly accelerated when connectors are not kept clean, or are not connected properly.

Connector wear eventually degrades performance of the device. Calibration components should have a long life if their use is on the order of a few times per week. Replace components with worn connectors.

The test port connectors on the network analyzer test set may have many connections each day, and are therefore more subject to wear. It is recommended that an adapter be used as a test port saver to minimize the wear on the test set's test port connectors.

Inspect the Mating Plane Surfaces

Flat contact between the connectors at all points on their mating plane surfaces is required for a good connection. Look especially for deep scratches or dents, and for dirt and metal particles on the connector mating plane surfaces. Also look for signs of damage due to excessive or uneven wear or misalignment.

Light burnishing of the mating plane surfaces is normal, and is evident as light scratches or shallow circular marks distributed more or less uniformly over the mating plane surface. Other small defects and cosmetic imperfections are also normal. None of these affect electrical or mechanical performance.

If a connector shows deep scratches or dents, particles clinging to the mating plane surfaces, or uneven wear, clean and inspect it again. Devices with damaged connectors should be discarded. Determine the cause of damage before connecting a new, undamaged connector in the same configuration.

Contacting Agilent

Assistance with test and measurement needs and information on finding a local Agilent office are available on the Web at:

www.agilent.com/find/assist

NOTE In any correspondence or telephone conversation, refer to the Agilent product by its model number and full serial number. With this information, the Agilent representative can determine whether your product is still within its warranty period.
