

**OPERATING AND SERVICE MANUAL
MODIFICATION**

MODEL 8662A

OPTION H08

SYNTHESIZED SIGNAL GENERATOR

How to Use This Insert

This Manual Modification Insert should be used in conjunction with the HP 8662A Operating and Service Manual, Volume I (HP Part Number 08662-90061) and Volume II (HP Part Number 08662-90062), both printed February 1982. Make the changes described in this Insert to the indicated Sections of the Operating and Service Manuals.

Applicable Serial Numbers

This Manual Modification Insert applies to instruments with serial number prefixes greater than or equal to 2413A.

Updates to this Manual Insert

Periodically, changes are made to the Manual Insert to correct errors in the original printing and to include Option improvements. Corrections are indicated by a mark at the right-hand edge of the modified text. The mark used is keyed to the date the corrections are added (found on this cover below the issue date).

Manual Modification Insert
HP Part Number 08662-92038

Issued June 1984

SECTION I. GENERAL INFORMATION

Option H08 to the 8662A Synthesized Signal Generator provides an internal 60 MHz RF Signal from the LO Driver section of the instrument output a rear-panel connector. This option cannot be ordered with Option 001 or Option C02 because the rear-panel MOD INPUT connector location is utilized for the 60 MHz OUTPUT.

On page 1-9, in Table 1-2, Supplemental Characteristics, add the following under FREQUENCY:

60 MHz OUTPUT (high impedance source):
60 MHz sinewave signal available from a rear-panel connector at a nominal level of >0dBm into 50 ohms. Do not apply reverse dc, ac or RF power to this input.

SECTION III. OPERATION

On page 3-1, add the following under paragraph 3-2, Operating Characteristics:

The HP Model 8662A Option H08 may be operated as a standard instrument when Option H08 is not in use. No significant degradation of standard specifications will result from use in this configuration.

On page 3-17, replace part of Figure 3-7, Rear Panel Features, with the partial Figure 3-7A, Rear Panel Features, on page 5 of this Insert.

SECTION IV. PERFORMANCE TESTS

Option H08 to the 8662A does not affect any performance tests.

SECTION V. ADJUSTMENTS

Certain adjustments, such as 5-8, the 40 MHz CRYSTAL FILTER ADJUSTMENT, 5-9, the 160 MHz and 640e MHz BAND-PASS FILTER ADJUSTMENT, and 5-10, the 480 MHz BAND PASS FILTER ADJUSTMENT, directly affect the RF level of the 60 MHz OUTPUT signal. Therefore, use caution when making any adjustments on Option H08, and verify the 60 MHz RF level after making any such adjustments.

SECTION VI. REPLACEABLE PARTS

In Table 6-3, Replaceable Parts, add or delete the following parts as noted:

Add or Del	Page No.	Refer. Desig.	HP Part Number	Qty	Description
D	6-64	A6A2	08662-60114	1	LO Drive Assembly
A	6-64	A6A2	08662-62029	1	LO Drive Assembly, Option H08
A	6-65	A6A2J3	----	1	NSR, P/O A6A2W1
A	6-65	A6A2MP10	0361-1076	1	Eyelet, Roll Flange, 0.047"OD, 0.093"L
A	6-66	A6A2W1	08662-22030	1	Cable, Semi-rigid (Includes A6A2J3)
A	6-66	-----	2190-0124	1	Lock washer, #10, 0.195"ID, (for A6A2J3)
A	6-66	-----	2950-0078	1	Hex nut, 10-32thd, 0.067"thick, (for A6A2J3)
A	6-93	A11	08662-62030	1	60MHz Low Pass Filter Assembly
A	6-93	A11MP1	11710-80001	1	Cover, Bottom
A	6-93	A11MP2	11710-80002	1	Can, LPF
A	6-93	A11MP3	2190-0124	2	Lock washer, #10, 0.195"ID
A	6-93	A11MP4	2950-0078	2	Hex nut, 10-32thd, 0.067"thick
A	6-93	A11A1	08662-62031	1	60MHz Low Pass Filter Brd. Assy.
A	6-93	A11A1C1	0610-3879	1	Cap-Fxd 0.01uF +/-20% 100Vdc Cer
A	6-93	A11A1C2	0160-4527	2	Cap-Fxd 56pF +/-5% 200Vdc Cer
A	6-93	A11A1C3	0160-4389	1	Cap-Fxd 100pF +/-5% 200Vdc Cer
A	6-93	A11A1C4	0160-4527		Cap-Fxd 56pF +/-5% 200Vdc Cer
A	6-93	A11A1J1	1250-1220	2	RF-conn, SMC male, P.C., 50 ohm
A	6-93	A11A1J2	1250-1220		RF-conn, SMC male, P.C., 50 ohm
A	6-93	A11A1L1	9100-2250	2	Inductor RF-CH-MLD 180nH 10%
A	6-93	A11A1L2	9100-2250		Inductor RF-CH-MLD 180nH 10%
A	6-93	A11A1R1	0698-7228	1	Res-Fxd, 464 ohm, 1%, 0.05W
D	6-101	MP109	08662-00028	1	Deflector, Air
A	6-101	MP109	08662-02028	1	Deflector, Air, Option H08
D	6-101	MP112	08662-00216	1	Rear Support Panel, BNC
A	6-101	MP112	08862-02030	1	Rear Support Panel, BNC, Opt H08
D	6-101	MP127	0590-1011	2	Kurl Nut, 15/32-32thd, 0.12"thk
A	6-101	MP127	2950-0035	4	Hex nut, Dbl-Chm, 15/32-32thd

Table 6-3. Replaceable Parts (Cont'd):

Add or Del	Page No.	Refer. Desig.	HP Part Number	Qty	Description
D	6-101	MP128	2190-0068	2	Washer-Lk, Intl T 1/2", 0.505"ID
A	6-101	MP128	2190-0102	4	Lock washer, Intl T 15/32", 0.472"ID
A	6-103	W102	08662-62027	1	Cable Assy. (957), flex., 50 ohm
A	6-103	W103	08662-62028	1	Cable Assy. (956), flex., 50 ohm
A	6-103	W103J1	1250-0870	1	RF-conn, BNC fem, 50 ohm

SECTION VIII. SERVICE

On page 8-203, in table 8-202, Failures Associated With External connectors, incorporate the following:

Connector	Troubleshoot Assembly (Service Sheet)	
60 MHz OUTPUT	A6A2	(21)
	A11	(21A)

On page 8-205 (Service Sheet A), in Figure 8-201, Overall Block Diagram, replace section C with the figure on page 6 of this Insert.

On page 8-215 (Service Sheet C), in Figure 8-206, Reference Section Block Diagram, replace part of the diagram showing A6A3 and A6A2 with the figure on page 7 of this Insert.

On page 8-408 (Service Sheet 21), add the following after the last paragraph:

Description of Option H08 Modification

The A6A2 LO Driver Assembly has been modified by the installation of a semi-rigid cable connected between pin 2 of U1A and an added subminiature coaxial connector (part of the semi-rigid cable) on the shielded cover for the assembly. This SMC connector is labeled "J3 OUTPUT, 60 MHz". From this connector a flexible coaxial cable (W102) routes the 60 MHz signal to the A11 60 MHz Low Pass Filter Assembly mounted on the air deflector at the rear of the instrument.

From the 60 MHz Low Pass Filter Assembly a flexible coaxial cable (W013) routes the 60 MHz signal to a BNC connector mounted on the rear panel. Also, a jumper wire has been installed between A6A2U2 pin 10 and A6A2U2 pin 15 (ground) to enable divider A6A2U1 at all times.

Also on page 8-408 (Service Sheet 21), add Figure 8-410A, Pictorial View of Modified A6A2 Assembly, as shown on page 8 of this Insert.

On page 8-409 (Service Sheet 21), in Figure 8-411, A6A2 Reference Section LO Drive Block Diagrams, replace the diagram at the bottom of the page with the diagram on page 9 of this Insert.

Also on page 8-409, in Figure 8-412, A6A2 Reference Section LO Drive Schematic, replace part of Figure 8-412 with the partial schematic on page 10 of this Insert.

After page 8-409, add page 8-409A, (Service Sheet 21A) containing Figure 8-412A, the All 60 MHz Low Pass Filter Schematic, shown on page 11 of this Insert.

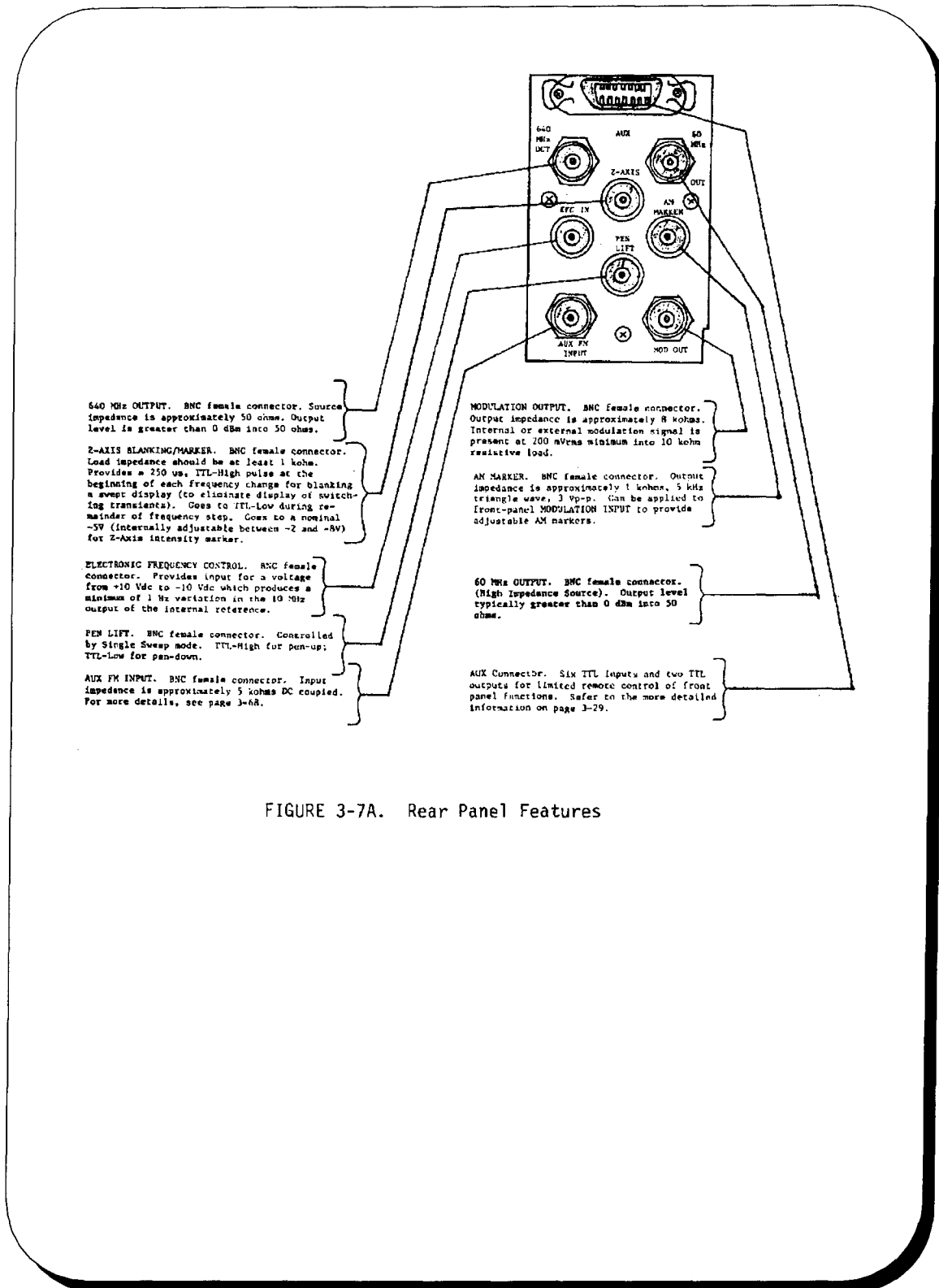
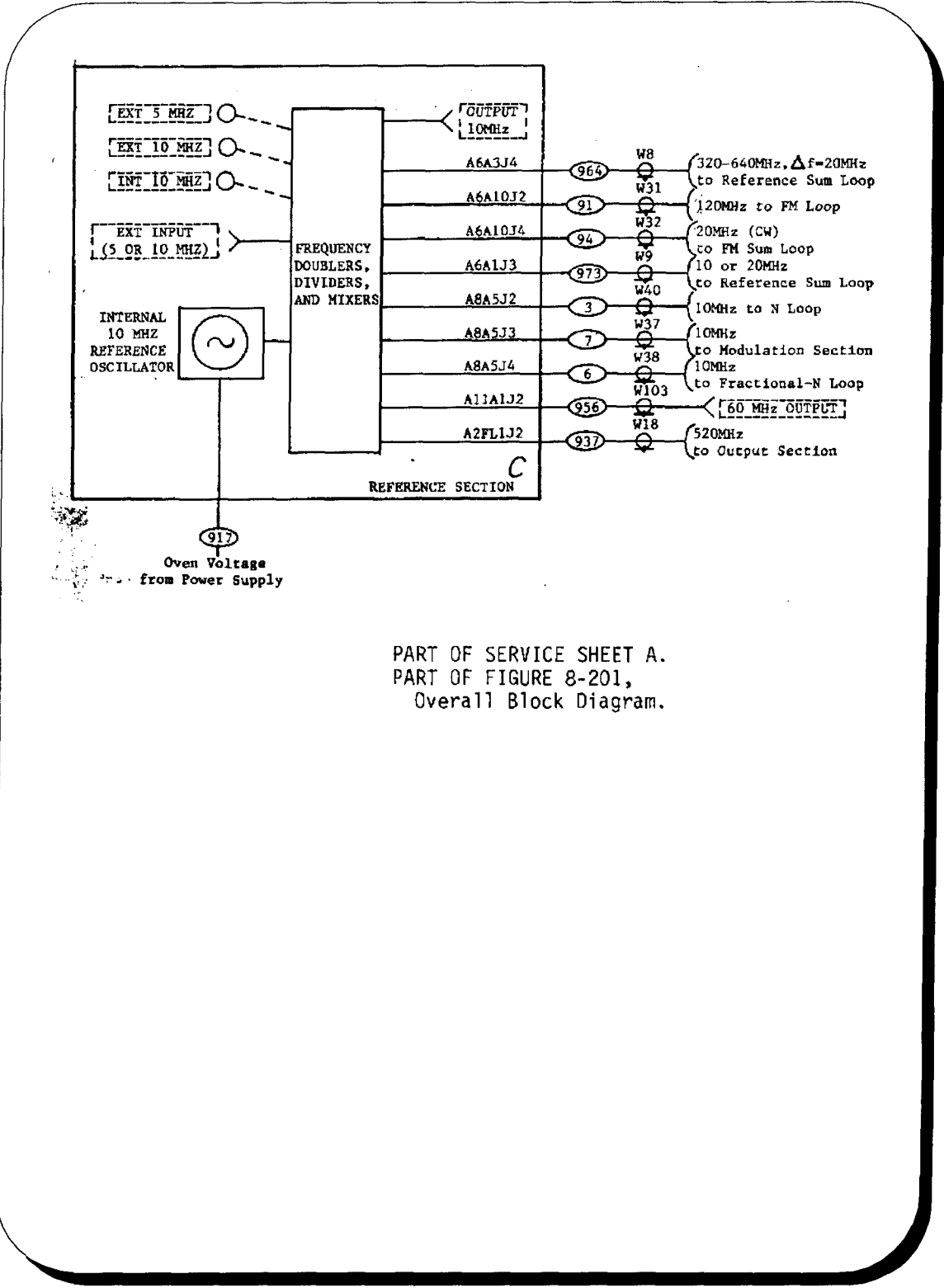
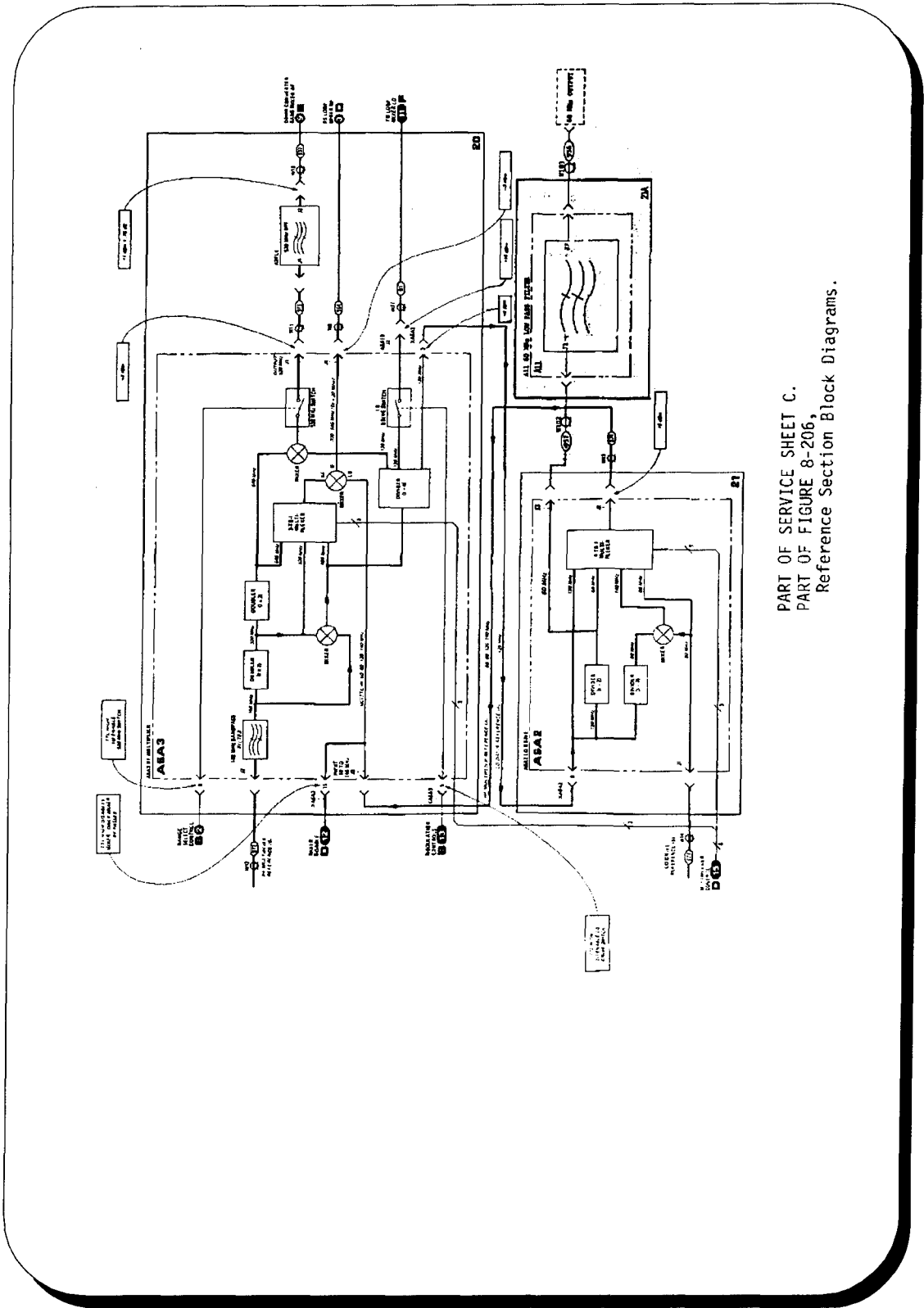

FIGURE 3-7A. Rear Panel Features



PART OF SERVICE SHEET A.
 PART OF FIGURE 8-201,
 Overall Block Diagram.



PART OF SERVICE SHEET C.
 PART OF FIGURE 8-206.
 Reference Section Block Diagrams.

A6A2 ASSEMBLY

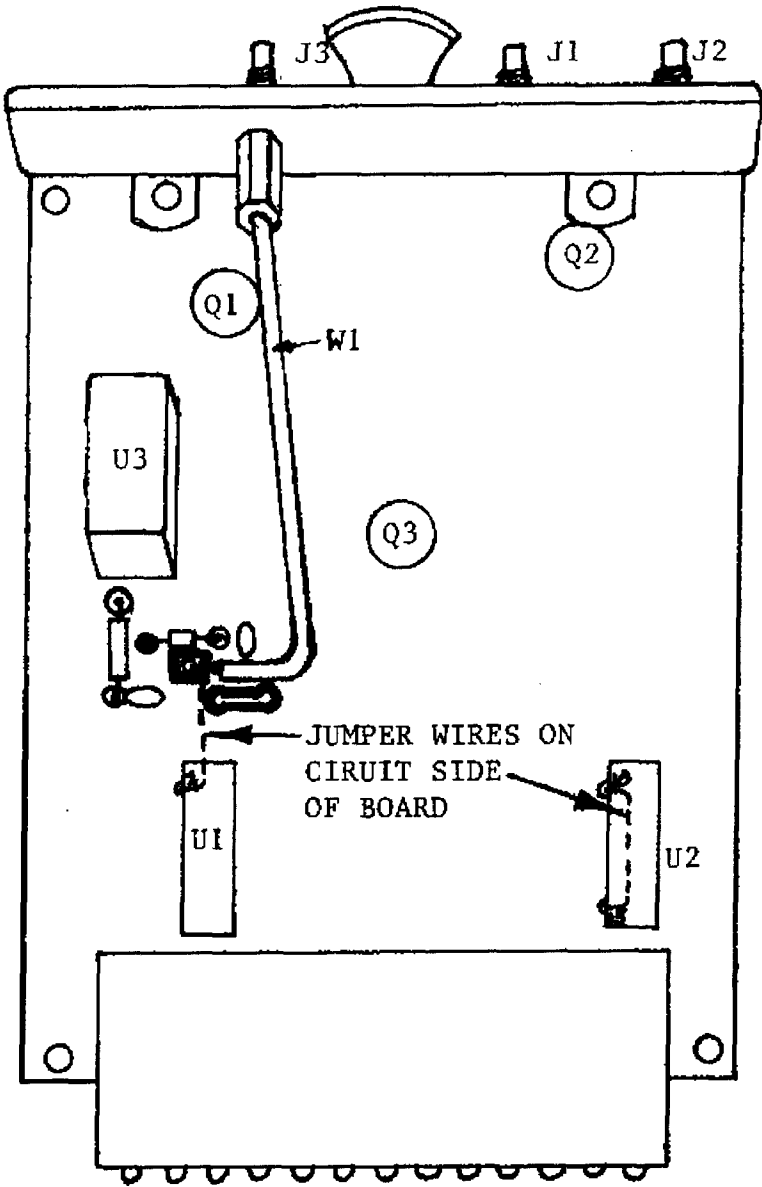
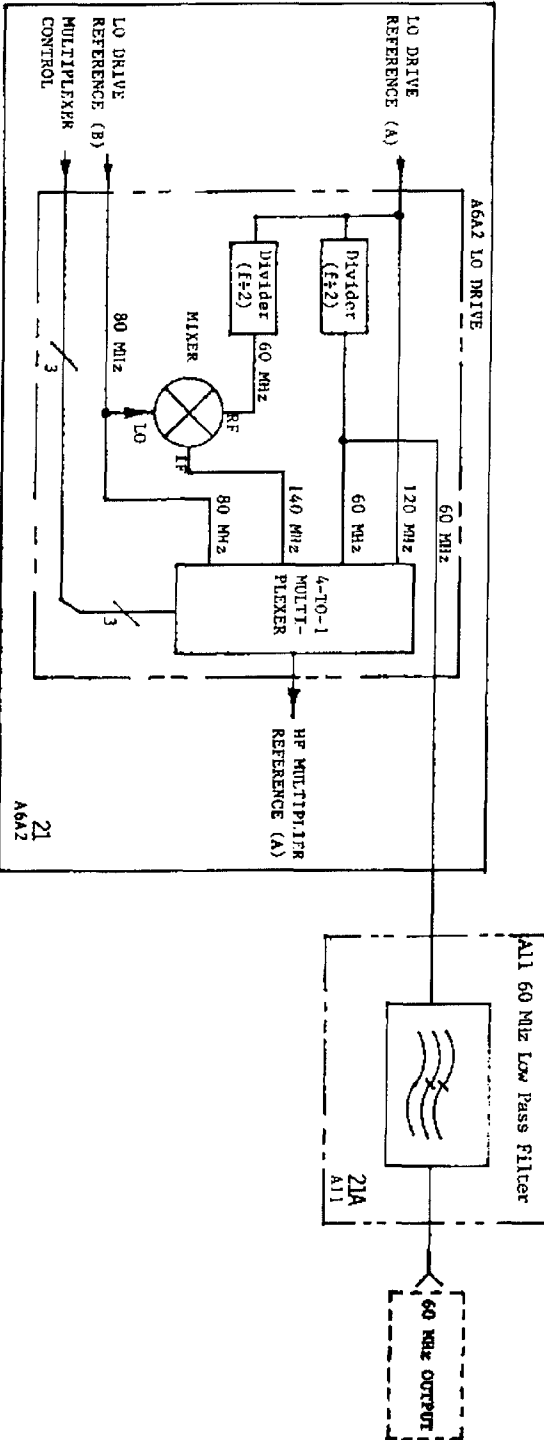
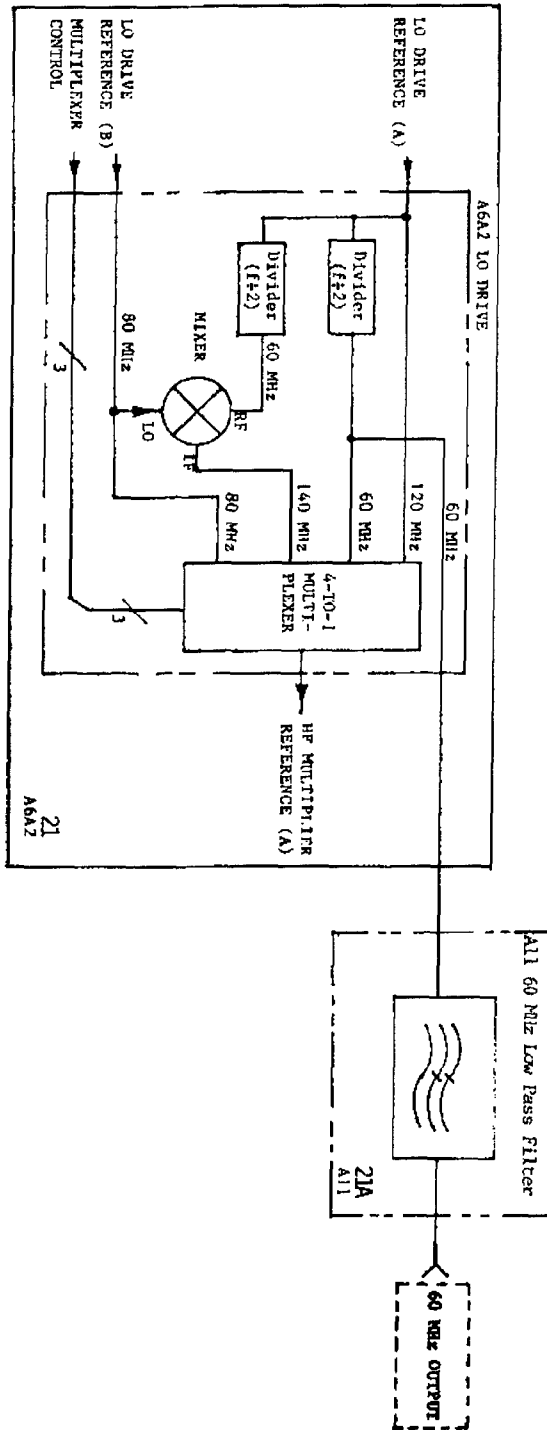

FIGURE 8-410A. Pictorial View of Modified A6A2 Assembly.



PART OF SERVICE SHEET 21.
 PART OF FIGURE 8-411,
 A6A2 Reference Section LO Drive and
 All 60 MHz Low Pass Filter Block Diagrams.



PART OF SERVICE SHEET 21.
 PART OF FIGURE 8-411,
 A6A2 Reference Section LO Drive and
 A11 60 MHz Low Pass Filter Block Diagrams.

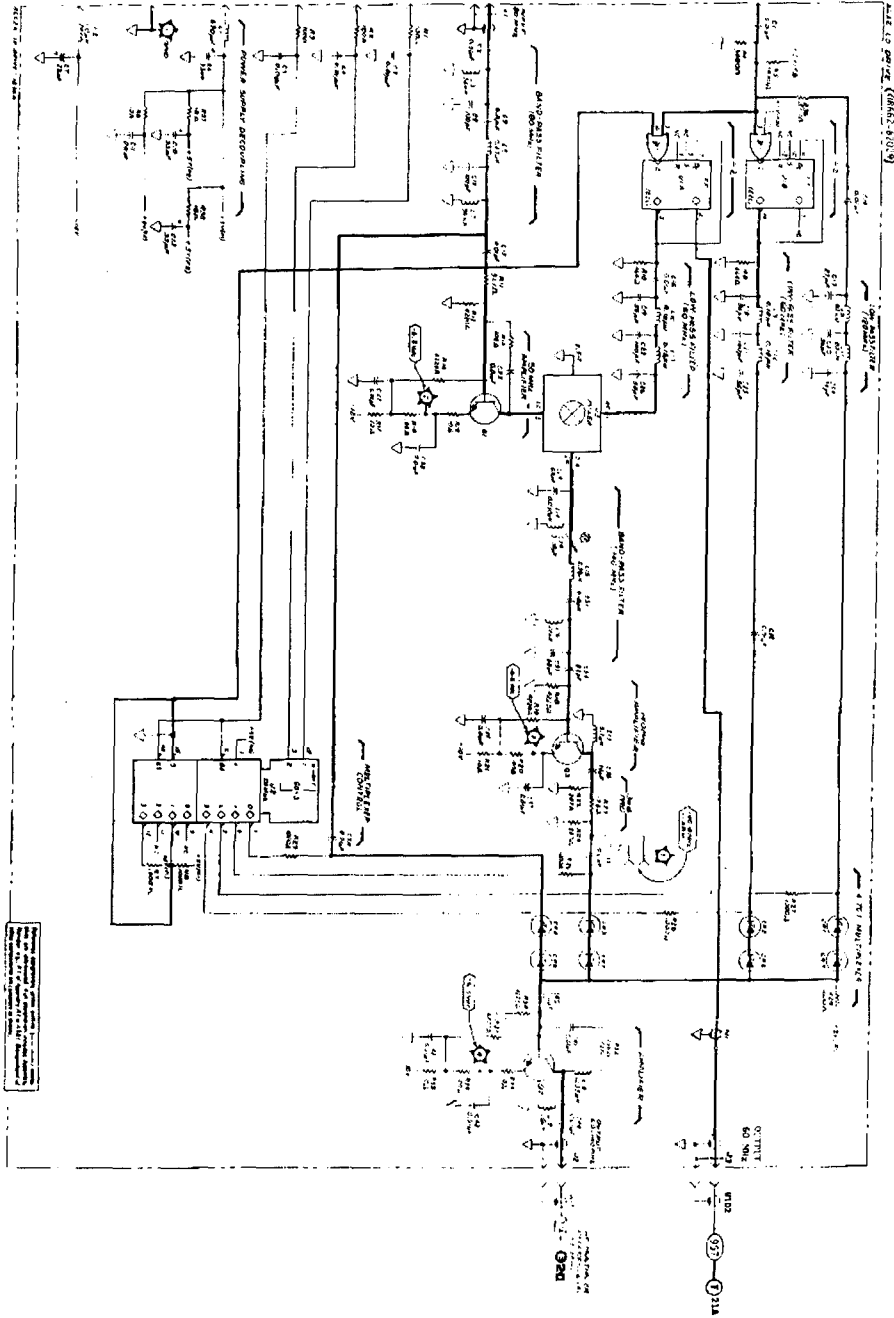

PART OF SERVICE SHEET 21.
PART OF FIGURE 8-412,
A6A2 Reference Section L0 Drive Schematic.

**OPERATING AND SERVICE MANUAL
MODIFICATION**

MODEL 8662A

OPTION H11

SYNTHESIZED SIGNAL GENERATOR

How to Use This Insert

This Manual Modification Insert should be used in conjunction with the 8662A Operating and Service Manuals, Volumes 1 and 2, HP Part Number 08662-90069 (printed May 1990). Make the changes described in this Insert to the indicated sections of the Operating and Service Manuals.

Applicable Serial Numbers

This Manual Modification Insert applies to instruments with serial number prefixes greater than or equal to 2612A.

Updates to this Manual Insert

Periodically, changes are made to the Manual Insert to correct errors in the original printing and to include Option improvements. Corrections are indicated by a mark at the right-hand edge of the modified text. The mark used is keyed to the date corrections are added (found on this cover below the issue date).

Manual Modification Insert
HP Part Number 08662-92019

Rewritten May 1986
Updated October 1995

SECTION I. GENERAL INFORMATION

Option H11 for the 8662A Synthesized Signal Generator provides front panel and HP-IB selection of either the internal 10 MHz Reference Oscillator or an external 10 MHz Reference Source. Internal battery-powered memory will retain the last mode selected even if line power is removed. This option also deletes the provision for an external 5 MHz Reference and changes the Auxiliary FM feature so that it cannot be controlled by special functions.

On page 1-9, in Table 1-2, Supplemental Characteristics (1 of 2), under FREQUENCY, incorporate the following:

EXTERNAL: Option H11 deletes the external 5 MHz input capability on the rear panel connector, but retains 10 MHz operation.

On page 1-10, in Table 1-2, Supplemental Characteristics (2 of 2), under EXTERNAL MODULATION, add the following:

AUXILIARY FM INPUT: Option H11 has been produced so that this function is hardwired in the "Off" position. An internal jumper wire must be moved in order to turn this input "On".

SECTION III. OPERATION

On page 3-5, replace Section 3-9, Reference Selection, with the following:

The 8662A Option H11 deletes the three reference signal switches normally located on the rear panel. The INPUT connector can accept a 10 MHz reference signal to be used instead of the generator's internal reference.

The internal reference is a 10 MHz signal with an aging rate of $<5 \times 10^{-10}$ /day after warm-up (typically after 24 hours). Selecting Special Function 00, Special Function 50, or the HP-IB Clear Message will configure the instrument to use this internal reference.

To use an external 10 MHz source, select Special Function 51. This will disable the internal reference and enable the INPUT connector for a 10 MHz signal at $>+7$ dBm.

The OUTPUT connector provides a 10 MHz signal ($>+7$ dBm) derived from the selected reference. The OUTPUT connector does not require any switching.

On page 3-17, replace part of Figure 3-7, Rear Panel Features, with the partial figure on page 10 of this Insert.

On page 3-39, in Table 3-7, Response to Clear Message, incorporate the following:

Parameter	Condition
10 MHz Reference Source	Internal 10 MHz Reference

On page 3-43, in Section 3-53, Reading Control Settings, under Modulation, change the table entries and footnote under Step 2 as follows:

Source Code	Modulation Modes	
	Internal (Rate)	External (Coupling)
128 128 and above	-- --	None Depends on source code of other mode selected
FOOTNOTE		
A Source Code of 128 will enable Special Function 51 which will select the external 10 MHz reference source. A Source Code above 128 will enable the external 10 MHz reference source and a Modulation Mode from the table above. To interpret a Source Code above 128, first subtract 128, then interpret the remaining value from the above table entries.		

On page 3-49, change part of Table 3-10, Special Function Codes, to read as follows:

Special Function	Code
AUX FM Off	None
AUX FM On	None
EXT 10 MHz Off	50
EXT 10 MHz On	51

On page 3-68, Modulation, External Source, under procedure, replace the last two paragraphs with the following:

Option H11 deletes Special Function selection of the AUX FM INPUT. The instrument is shipped with the AUX FM INPUT hardwired in the "OFF" position. Option H11 retains the AUX FM INPUT capability, but must be rewired internally for an "ON" position. Therefore, all standard specifications and operation procedures apply other than as noted above.

NOTE

The above applies to all Special Function and HP-IB references concerning the AUX FM INPUT throughout the Operating and Service Manuals for the 8662A.

WARNING

Reconfiguration of jumper wires as described below should be performed only by service trained personnel who are aware of the possible hazards involved (for example, fire and electrical shock). Remove the power cord before removing the instrument covers.

To enable the rear panel AUX FM connector, a jumper wire on the A4A9 Modulation Drive Assembly must be connected from pin 3 of A4A9U7A to pin 14 of A4A9U6A. See Figure 8-537A on page 18 of this Insert and P/O Figure 8-539 on page 20 of this Insert.

To disable the rear panel connector, the jumper wire must be connected from pin 11 of A4A9U7A to pin 3 of A4A9U7A. See Figure 8-537A on page 18 of this Insert and P/O Figure 8-539 on page 19 of this Insert.

On page 3-69, in Comments (Cont'd), under Greater Stability, replace the NOTE with the following:

NOTE

AM + FM is possible, with reduced stability, by using a second external source for FM and the rear panel AUX FM INPUT (enabled with a jumper wire on the A4A9 board).

On page 3-70, in Comments, replace the paragraph starting with "DC Coupling with Phase Lock" and the next paragraph with the following:

DC COUPLING WITH PHASE LOCK. For external control of FM peak deviation (for signals entering the rear panel AUX FM INPUT):

- * Enable the AUX FM connector by performing the changes described in the preceding section titled Procedure on page 3-68.

On page 3-74, Modulation, Mixed, delete the last line in Description: (Special Function 51).

On page 3-74, under Procedure, replace the lines labeled AUX FM ON and OFF with the following:

AUX FM ON: The jumper on the A4A9 board must be connected from pin 14 of A4A9U6A to pin 3 of A4A9U7A. See Figure 8-537A on page 18 of this Insert and P/O Figure 8-539 on page 20 of this Insert.

AUX FM OFF: The jumper on the A4A9 board must be connected from pin 3 of A4A9U7A to pin 11 of A4A9U7A. See Figure 8-537A on page 18 of this Insert and P/O Figure 8-539 on page 19 of this Insert.

On page 3-74, change the second example as follows:

Enable the Rear panel AUX FM connector.	
Local	Connect jumper on A4A9 board as described in procedure above.
HP-IB Program Codes	Not Applicable for Option H11

On page 3-80, Table 3-11, Special Function, modify the table as shown below:

Function	Codes
Auxiliary FM Off	None
Auxiliary FM On	None
External 10 MHz Reference Off	50
External 10 MHz Reference On	51

On page 3-80, Table 3-12, Initializing; Response to Special Function 00, add the following to the end of the Table:

Parameter	Condition
10 MHz Reference Source	Internal 10 MHz Reference

On page 3-82, Table 3-14, Special Function Status Codes, change entry 51 to read as follows:

51	External 10 MHz Reference Enabled
----	-----------------------------------

SECTION IV. PERFORMANCE TESTS

On page 4-23, in Section 4-11, INTERNAL TIME BASE AGING TEST, change step 1 of the PROCEDURE to read as follows:

1. Press the Blue Key, SPECIAL, and 00 to initialize the instrument and to select the internal 10 MHz reference oscillator.

SECTION V. ADJUSTMENTS

On page 5-9, in Paragraph 5-7, 10 MHz REFERENCE OSCILLATOR ADJUSTMENT, change step 4 under PROCEDURE to read as follows:

4. Press the Blue Key, Special, and 00 to select the internal 10 MHz reference oscillator.

SECTION VI. REPLACEABLE PARTS

In Table 6-3, Replaceable Parts, add or delete the following parts as noted:

Table 6-3. Replaceable Parts

Add or Delete	Page No.	Refer. Design.	HP Part Number	Qty	Description
D	6-15	A2A10	08662-60172	1	DCU MOTHER BOARD
A	"	"	08662-62020	1	DCU MOTHER BOARD (Option H11)
D	6-50	A4A9	08662-60183	1	MODULATION DRIVE ASSY
A	"	"	08662-62022	1	MODULATION DRIVE ASSY (Option H11)
D	6-91	A8A4	08662-60306	1	REFERENCE BUFFER ASSY. (Delete all reference designations under A8A4)
A	"	"	08662-62036	1	REFERENCE BUFFER ASSY (Option H11)
A	6-91	A8A4C7	0160-3879	10	CAP-FXD 0.01UF +-20% 100VDC CER
"	"	A8A4C8	0180-2617	2	CAP-FXD 6.8UF +-10% 35VDC TA
"	"	A8A4C9	0160-3879		CAP-FXD 0.01UF +-20% 100VDC CER
"	"	A8A4C11	0180-0197	1	CAP-FXD 2.2 UF +-10% 20VDC TA
"	"	A8A4C12	0160-3879		CAP-FXD 0.01UF +-20% 100VDC CER
"	"	A8A4C14	0160-4031	1	CAP-FXD 330PF +-5% 100VDC CER
"	"	A8A4C15	0160-4588	1	CAP-FXD 270PF +-5% 100VDC CER
"	"	A8A4C16	0160-4389	1	CAP-FXD 100PF +-5PF 200VDC CER
"	"	A8A4C17	0160-3879		CAP-FXD 0.01UF +-20% 100VDC CER
"	"	A8A4C18	0180-2617		CAP-FXD 6.8UF +- 10% 35VDC TA
"	"	A8A4C19	0160-3879		CAP-FXD 0.01UF +-20% 100VDC CER
"	"	A8A4C20	0160-3879		CAP-FXD 0.01UF +-20% 100VDC CER
"	"	A8A4C21	0160-3879		CAP-FXD 0.01UF +-20% 100VDC CER
"	"	A8A4C22	0160-3879		CAP-FXD 0.01UF +-20% 100VDC CER
"	"	A8A4C23	0160-3879		CAP-FXD 0.01UF +-20% 100VDC CER
"	"	A8A4C24	0160-3879		CAP-FXD 0.01UF +-20% 100VDC CER
"	"	A8A4C28	0180-2205	1	CAP-FXD 0.33UF +-10% 35VDC TA
A	6-91	A8A4CR3	1901-0518	1	DIODE-Schottky SM Sig
	"	A8A4CR4	1901-0159	1	DIODE - PWR RECT 400V 750MA DO-41
A	6-91	A8A4J1	1250-0083	2	CONN-RF BNC F SGL-HOLE-FR 50 OHM
			2190-0016	2	WSHR-LK INTL T 3/8-in .377-IN-ID
			2950-0001	2	NUT-HEX-DBL-CHAM 3/8-32-THD .094-TK
"	"	A8A4J2	1250-0083		CONN-RF BNC F SGL-HOLE-FR 50 OHM
			2190-0016		WSHR-LK INTL T 3/8-in .377-IN-ID
			2950-0001		NUT-HEX-DBL-CHAM 3/8-32-THD .094-TK
A	6-91	A8A4 K2	0490-1034	1	RELAY 2C 12VDC-COIL .5A 350VDC
A	6-91	A8A4L4	9100-2260	1	INDUCTOR RF-CH-MLD 1.8UH 10%
A	6-91	A8A4MP1	08662-00025	2	SUPPORT, BNC BRACKET
			2200-0103	2	SCREW-MACH 4-40 .25-IN-LG PAN-HD-PZ
"	"	A8A4MP2	6960-0069	1	PLUG-HOLE CNCL-HD FOR .125-D NYL

Table 6-3. Replaceable Parts

Add or Del	Page No.	Refer. Desig.	HP Part Number	Qty	Description
A	6-91	A8A4 Q1	1854-0477	1	TRANS NPN 2N2222A SI TO-18 PD=500MW
"	"	A8A4Q2	1854-0247	1	TRANS NPN SI TO-39 PD=1W FT=800MHz
A	6-91	A8A4R7	0757-0346	1	RES-FXD 10 1% .125W F TC=0+-100
"	"	A8A4R8	0698-3438	1	RES-FXD 147 1% .125W F TC=0+-100
"	"	A8A4R11	0698-7243	2	RES-FXD 1.96K 1% .05W F TC=0+-100
"	"	A8A4R13	0698-7239	1	RES-FXD 1.33K 1% .05W F TC=0+-100
"	"	A8A4R14	0698-7198	5	RES-FXD 26.1 1% .05W F TC=0+-100
"	"	A8A4R15	0698-3437	1	RES-FXD 131 1% .125W F TC=0+-100
"	6-92	A8A4R16	0698-7251	2	RES-FXD 4.22K 1% .05W F TC=0+-100
"	"	A8A4R17	0698-7251		RES-FXD 4.22K 1% .05W F TC=0+-100
"	"	A8A4R18	0698-7260	1	RES-FXD 10K 1% .05W F TC=0+-100
"	"	A8A4R19	0698-7266	1	RES-FXD 17.8K 1% .05W F TC=0+-100
"	"	A8A4R20	0698-7284	1	RES-FXD 100K 1% .05W F TC=0+-100
"	"	A8A4R21	0698-7244	1	RES-FXD 2.15K 1% .05W F TC=0+-100
"	"	A8A4R22	0698-7277	1	RES-FXD 51.1K 1% .05W F TC=0+-100
"	"	A8A4R23	0698-7198		RES-FXD 26.1 1% .05W F TC=0+-100
"	"	A8A4R24	0698-7198		RES-FXD 26.1 1% .05W F TC=0+-100
"	"	A8A4R25	0698-7198		RES-FXD 26.1 1% .05W F TC=0+-100
"	"	A8A4R26	0698-7198		RES-FXD 26.1 1% .05W F TC=0+-100
"	"	A8A4R27	0698-7243		RES-FXD 1.96K 1% .05W F TC=0+-100
"	"	A8A4R28	0698-7265	2	RES-FXD 16.2K 1% .05W F TC=0+-100
"	"	A8A4R29	0698-7265		RES-FXD 16.2K 1% .05W F TC=0+-100
"	"	A8A4R30	0698-7253	2	RES-FXD 5.11K 1% .05W F TC=0+-100
"	"	A8A4R31	0698-7253		RES-FXD 5.11K 1% .05W F TC=0+-100
"	"	A8A4R32	0698-7236	1	RES-FXD 1K 1% .05W F TC=0+-100
"	"	A8A4R34	0698-7206	1	RES-FXD 56.2 1% .05W F TC=0+-100
"	"	A8A4R35	0698-7204	2	RES-FXD 46.4 1% .05W F TC=0+-100
"	"	A8A4R36	0698-7215	4	RES-FXD 133 1% .05W F TC=0+-100
"	"	A8A4R37	0698-7204		RES-FXD 46.4 1% .05W F TC=0+-100
"	"	A8A4R38	0698-7215		RES-FXD 133 1% .05W F TC=0+-100
"	"	A8A4R39	0698-7215		RES-FXD 133 1% .05W F TC=0+-100
"	"	A8A4R40	0698-7215		RES-FXD 133 1% .05W F TC=0+-100
"	"	A8A4R42	0757-1090	1	RES-FXD 261 1% .5W F TC=0+-100
"	"	A8A4R101	0698-7257	1	RES-FXD 7.5K 1% .05W FE TC=0+-100
"	"	A8A4R102	8159-0005	2	RES-ZERO OHMS 22AWG LEAD DIA
"	"	A8A4R103	8159-0005		RES-ZERO OHMS 22AWG LEAD DIA
A	6-92	A8A4T2	08662-80003	4	TRANSFORMER 14-TRN
"	"	A8A4T3	08662-80003		TRANSFORMER 14-TRN
"	"	A8A4T4	08662-80013	4	TRANSFORMER 12-TRN
"	"	A8A4T5	08662-80003		TRANSFORMER 14-TRN

Table 6-3. Replaceable Parts

Add or Delete	Page No.	Refer. Desig.	HP Part Number	Qty	Description
A	6-92	A8A4T6	08662-80003		TRANSFORMER 14-TRN
"	"	A8A4T7	08662-80013		TRANSFORMER 12-TRN
"	"	A8A4T8	08662-80013		TRANSFORMER 12-TRN
"	"	A8A4T9	08662-80013		TRANSFORMER 12-TRN
A	6-92	A8A4 U1	1826-0138	1	IC COMPARATOR GP QUAD 14-DIP-P PKG
"	"	A8A4U2	1826-0275	1	IC V RGLTR-FXD-POS 11.5/12.5V TO-92
A	6-92	A8A4 W1	8150-0033	A/R	WIRE 22 AWG WHITE
"	"	A8A4W2	8150-0033	A/R	WIRE 22 AWG WHITE
A	6-92	A8C101	0160-3036	1	CAP-FEEDTHRU- 5000PF +80-20% 200V
D	6-92	A8MP9	08662-20021	1	CASTING COVER, 10 MHz
A	"	A8MP9	08662-22028	1	CASTING COVER, 10 MHz (Option H11)
D	"	A8MP10	08662-20323	1	CASTING BASE, 10 MHz
A	"	A8MP10	08662-22035	1	CASTING BASE, 10 MHz (Option H11)
A	6-103	W101	08662-62043	1	24 AWG WIRE w/SINGLE CONTACT CONN

SECTION VIII. SERVICE

On page 8-204, in Table 8-203, Status Code Descriptions, change the description under Status Code 01 to read as follows:

No signal level or no reference oscillator. Special Function 50 should be enabled for internal reference oscillator.

On page 8-205, in Table 8-204, Special Function Status Codes, change the table as follows:

51	External 10 MHz reference enabled
----	-----------------------------------

On page 8-205 (Service Sheet A), in Figure 8-201, Overall Block Diagram, in Diagram C, REFERENCE SECTION: delete the EXT 5 MHz, EXT 10 MHz, and INT 10 MHz control function; delete the 5 MHz portion of the EXT INPUT; and add a note reading "INT 10 MHz = Special Function 50; EXT 10 MHz = Special Function 51."

On page 8-207/8-208 (Service Sheet B), replace part of Figure 8-202, Digital Control Unit (DCU) Block Diagram, with the partial figure on page 11 of this insert.

On page 8-214 (Service Sheet C), under PRINCIPLES OF OPERATION, delete the characters "5 MHz or" from the second paragraph.

On page 8-215 (Service Sheet C), replace part of figure 8-206, Reference Section Block Diagram, with the partial figure on page 12 of this insert.

On page 8-331 (Service Sheet 15), replace part of figure 8-345, P/O A2A3 Level/Modulation Schematic, with the partial schematic on page 13 of this insert.

On page 8-401 (Service Sheet 18), under PRINCIPLES OF OPERATION, replace the "General" and "Doubler Circuit" paragraphs with the paragraphs below, and then add the "Description of Option H11 Modification" at the end of the page:

GENERAL

The Reference Buffer amplifies and distributes the reference source signal to the rest of the instrument. The reference source can be the internal 10 MHz Reference Oscillator (A8A3) or an external frequency standard of 10 MHz. The internal reference oscillator is a high stability, temperature controlled, 10 MHz quartz oscillator.

DOUBLER CIRCUIT

The Doubler Circuit has been deleted in Option H11. The 10 MHz bandpass amplifier is still present.

DESCRIPTION OF OPTION H11 MODIFICATION

The 8662A with Option H11 has been modified so that what formerly was the signal to enable the AUX FM INPUT, now controls the 10 MHz reference source selected by the A8A4 Reference Buffer board.

This is done by cutting the trace on the A2A10 DCU Motherboard between pin 18 and pin 3. The AUX FM control signal is then routed to the 10 MHz Reference Oscillator Casting (A8MP10) through a newly installed 5000pf feedthrough capacitor, onto the A8A5 Reference Section Motherboard, and then to a special relay circuit on the A8A4 Reference Buffer board.

The AUX FM input circuitry remains intact, but is factory-configured in the "OFF" or disabled mode as shown on page 19 in the partial figure 8-539 and as described under Section III, Operation, of this Insert. AUX FM may be wired in the enabled mode on the A4A9 Modulation Drive board as shown on page 20 in the partial figure 8-539 and as described under Section III, Operation, of this Insert.

On page 8-402, replace Figure 8-401, A8A4 Reference Buffer Component Locations, with the new figure on page 14 of this Insert.

On page 8-403 (Service Sheet 18), replace Figure 8-402, A8A3 and A8A4 10 MHz Reference Oscillator and Buffer Block Diagrams, with the new figure on page 15 of this Insert.

On page 8-403 (Service Sheet 18), add Figure 8-402A, Block Diagram of Option H11 Circuitry found on page 16 of this Insert.

On page 8-403 (Service Sheet 18), replace part of Figure 8-403, A8A3 and A8A4 10 MHz Reference Oscillator Buffer Schematic, with the partial schematic on page 17 of this Insert.

On page 8-522 (Service Sheet 40), add Figure 8-537A, A4A9 Auxiliary FM ON-OFF jumper locations, found on page 18 of this insert.

On page 8-523/8-524 (Service Sheet 40), replace part of Figure 8-539, A4A9 Modulation Drive Schematic, with the partial schematics on page 19 and 20 of this Insert.

FREQUENCY REFERENCE. 10 MHz
reference output; impedance 50 ohms.
The output signal is derived from the
selected reference.

(Option H11 only) The reference is
switched from internal to external via
HP-IB or front panel using special
functions 50 and 51.

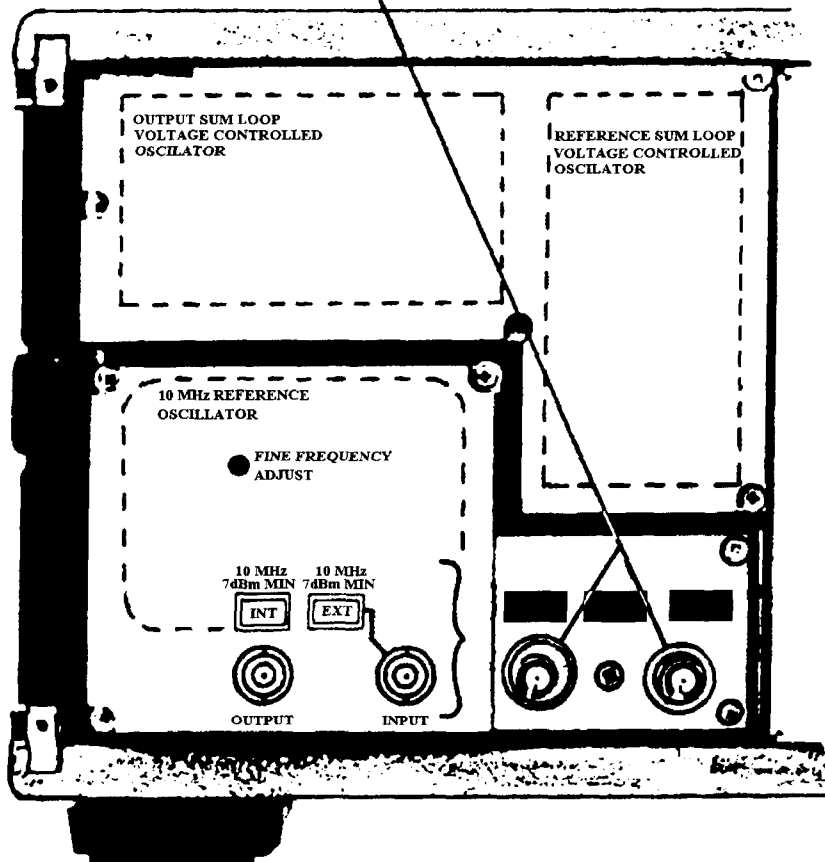

PART OF FIGURE 3-7. Rear Panel Features

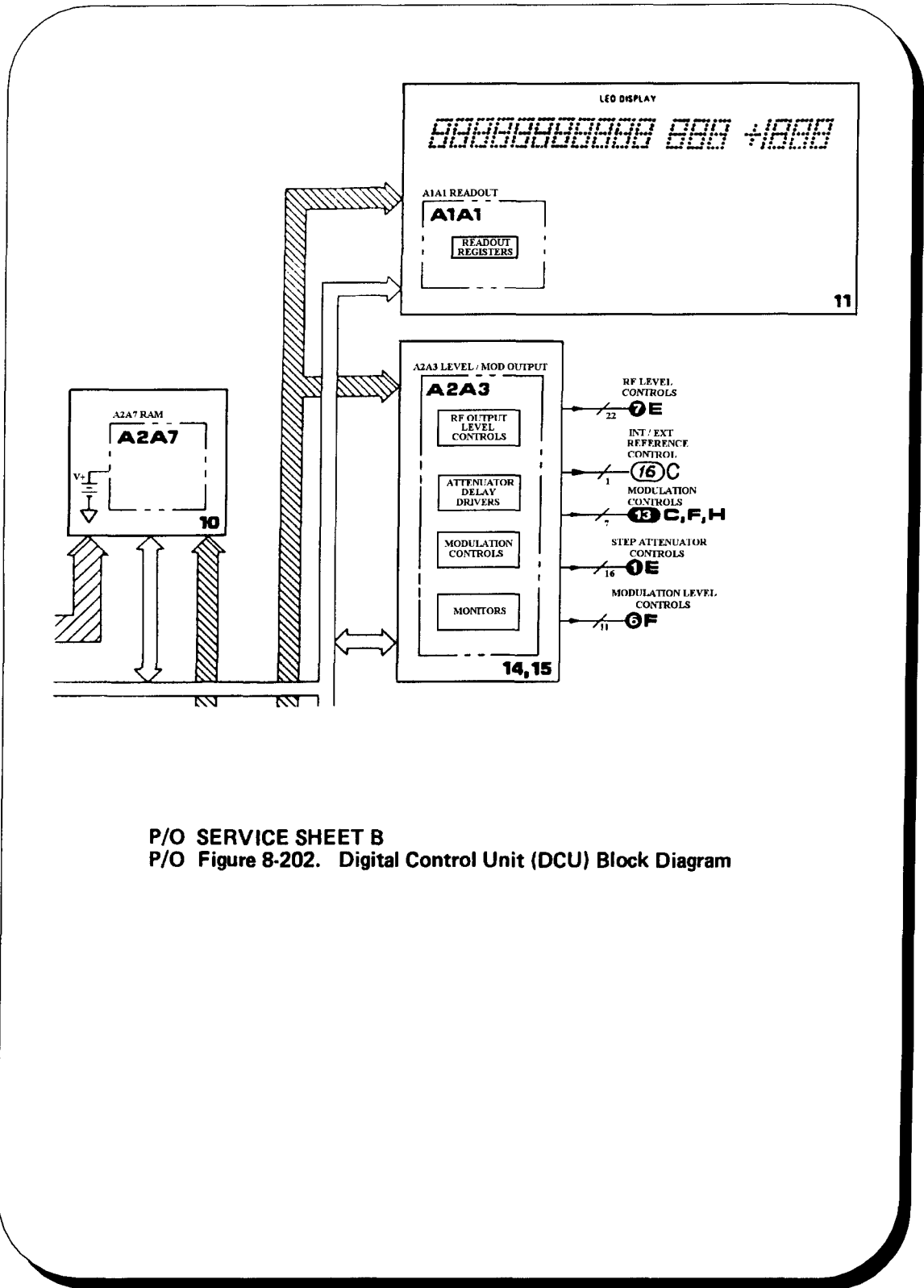

P/O SERVICE SHEET B
 P/O Figure 8-202. Digital Control Unit (DCU) Block Diagram

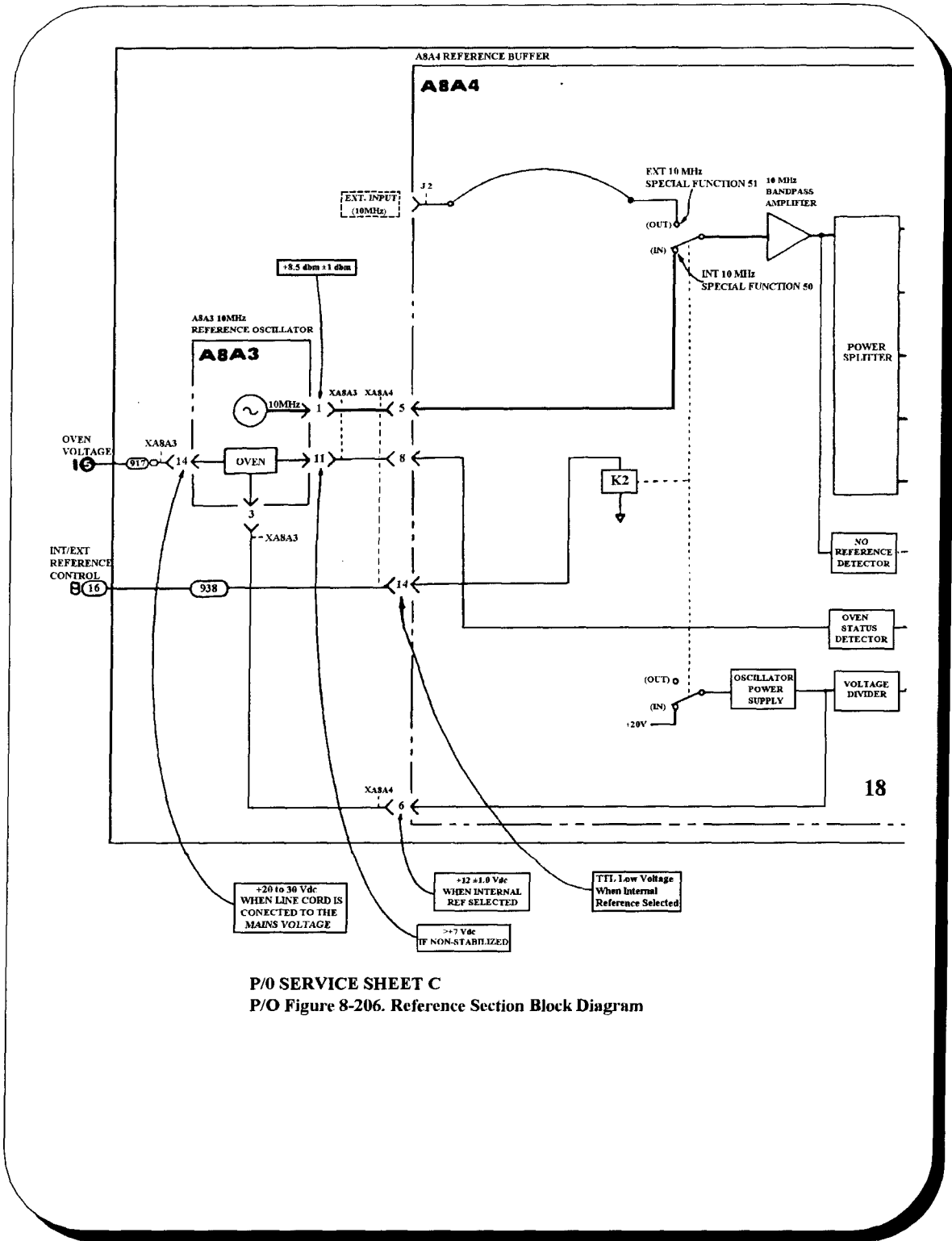

P/O SERVICE SHEET C
 P/O Figure 8-206. Reference Section Block Diagram

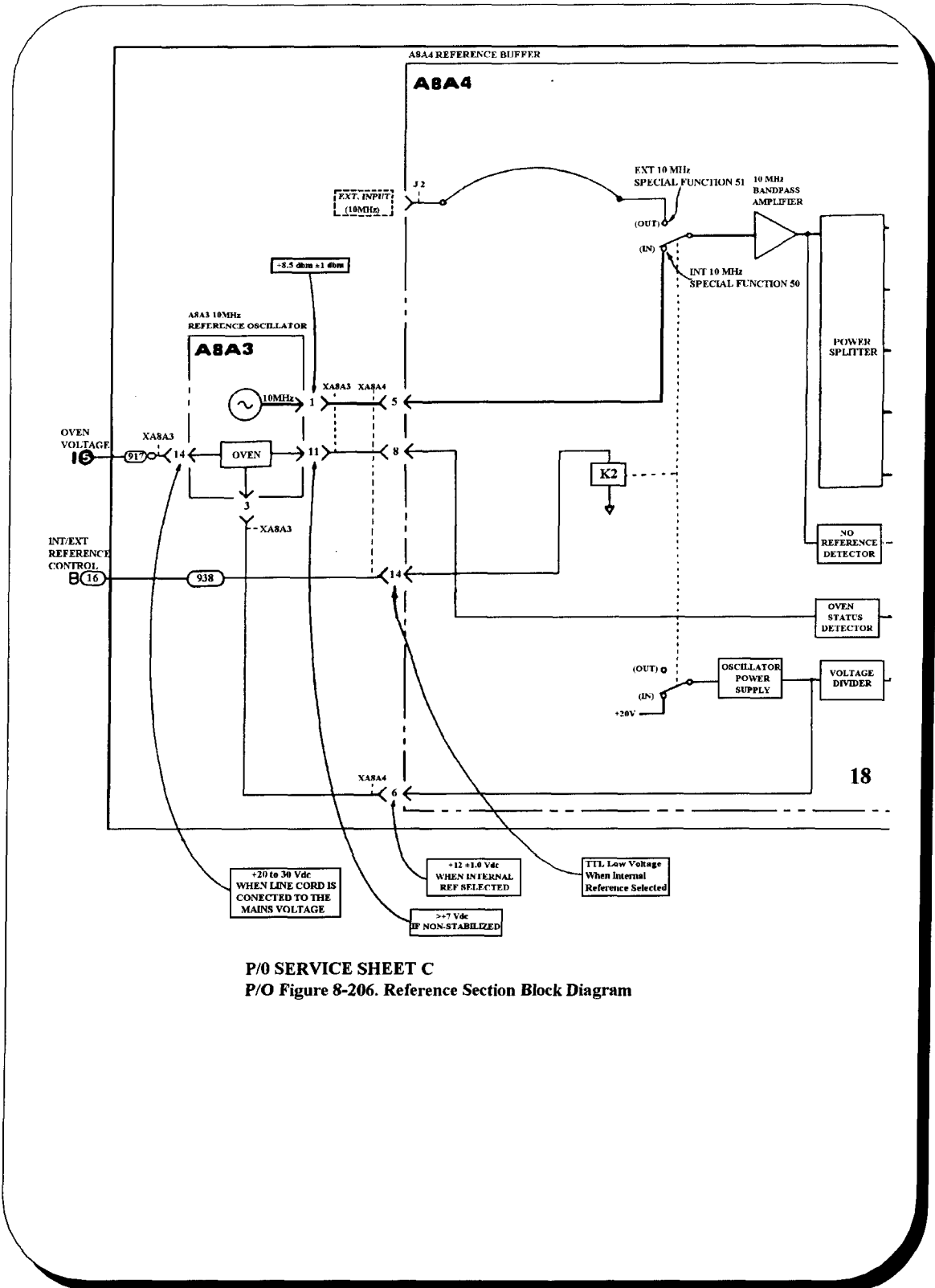

P/O SERVICE SHEET C
 P/O Figure 8-206. Reference Section Block Diagram

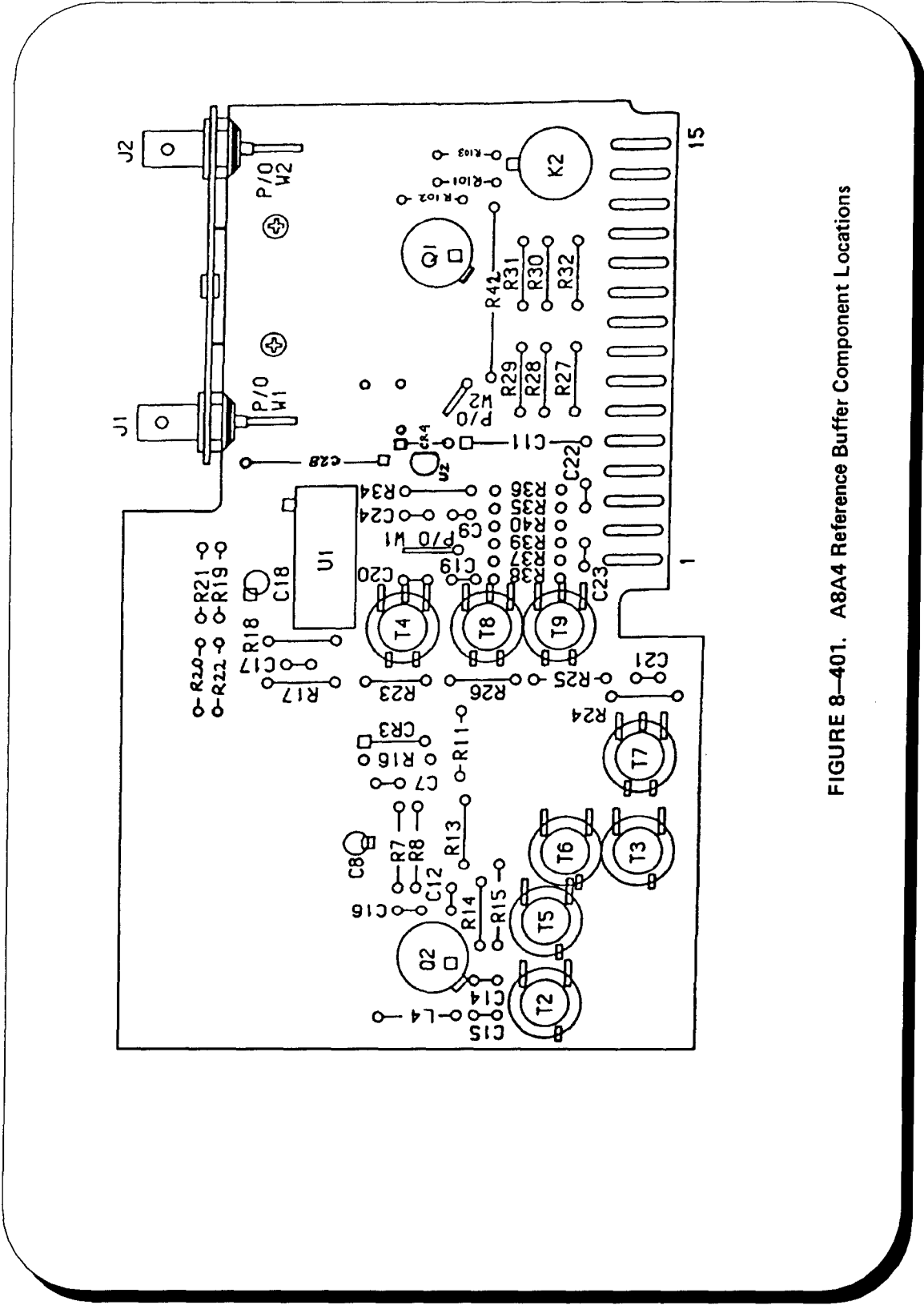

FIGURE 8-401. A8A4 Reference Buffer Component Locations

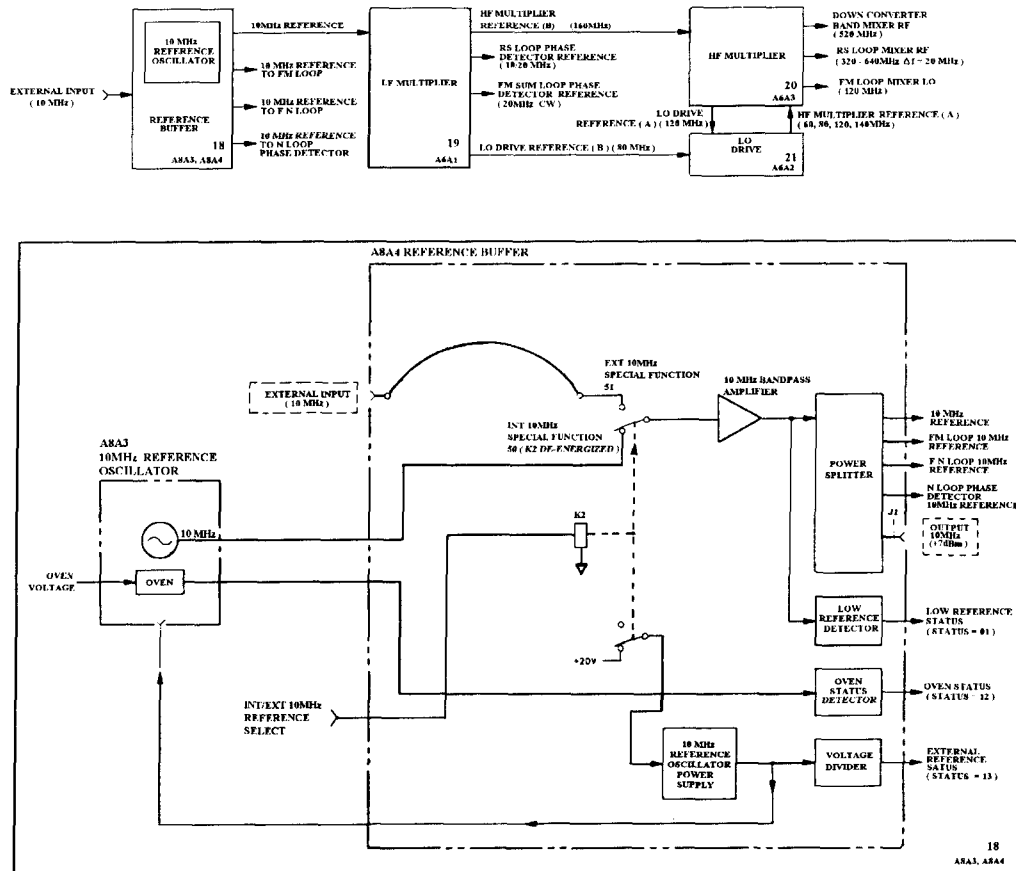
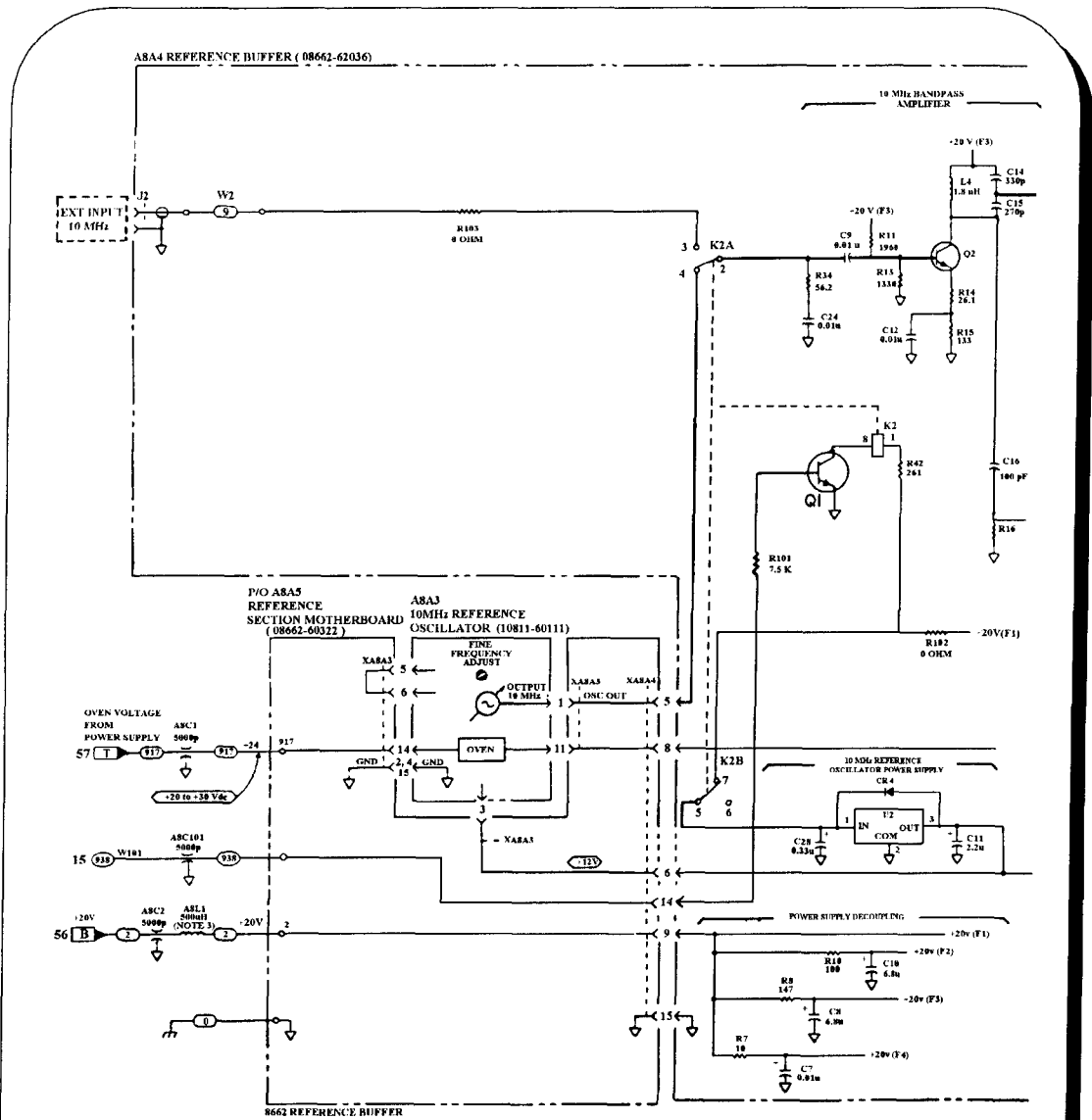
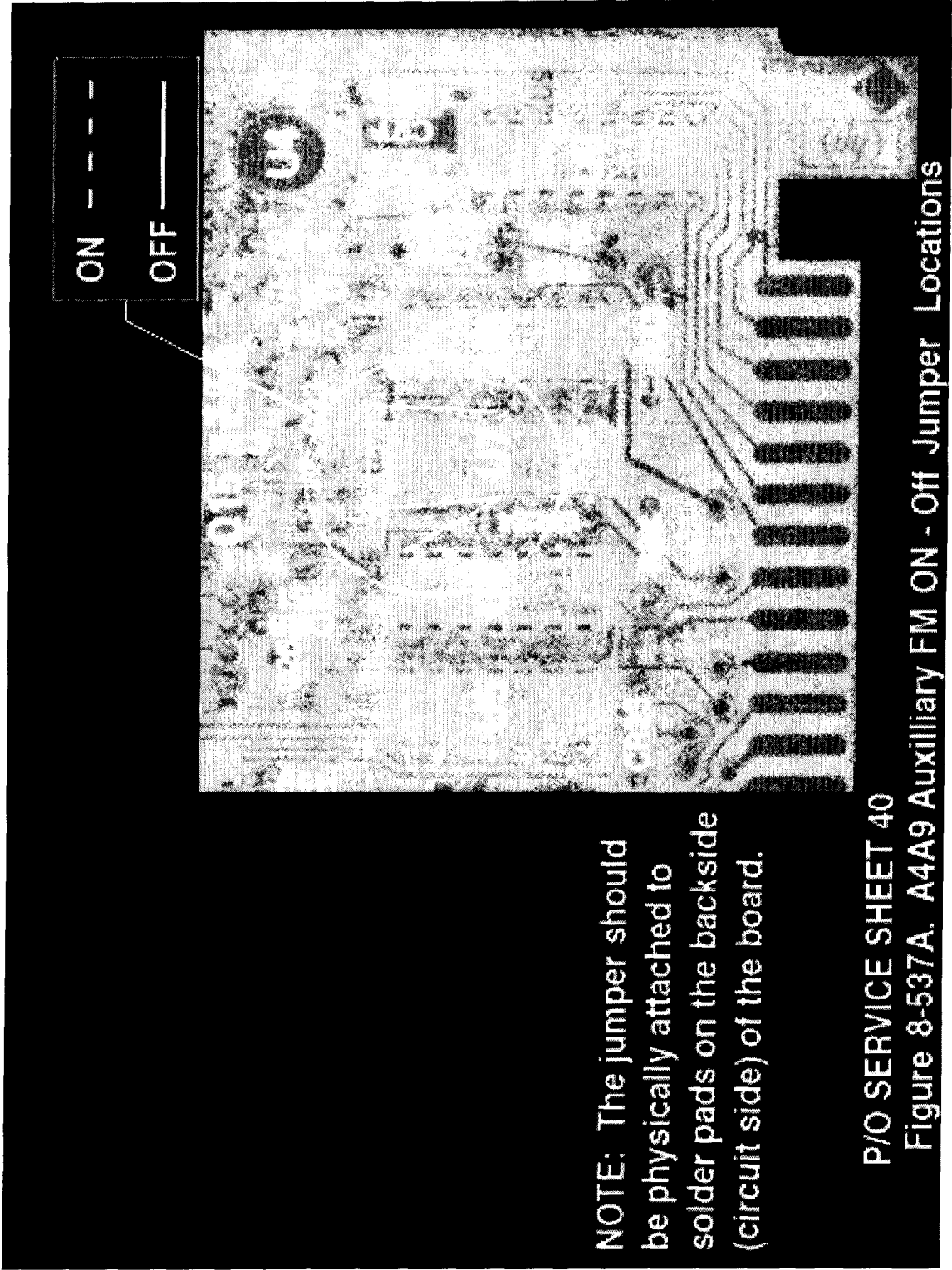
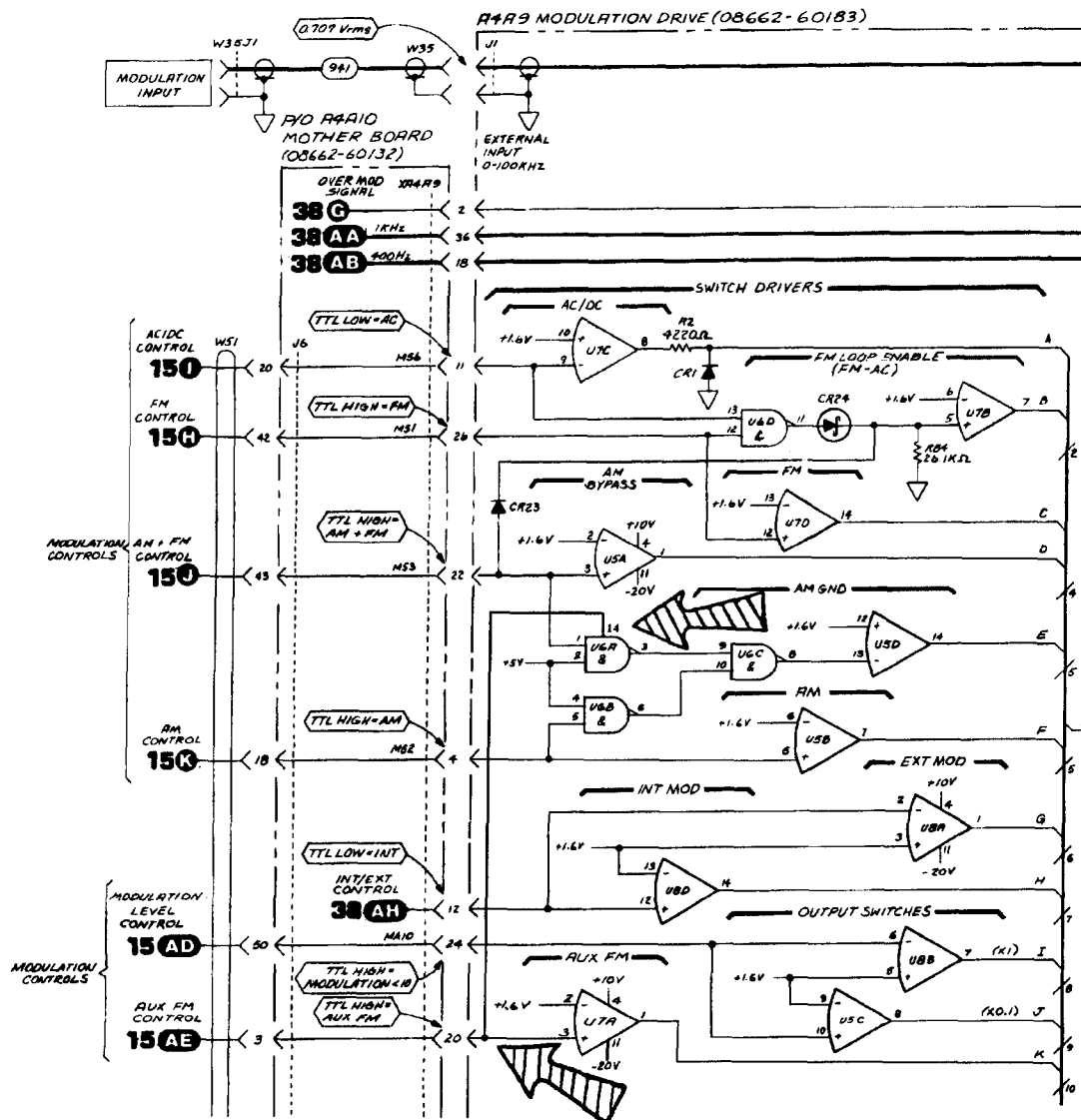

FIGURE 8 - 402. ABA3 and ABA4 10 MHz REFERENCE OSCILLATOR AND BUFFER BLOCK DIAGRAMS



P/O SERVICE SHEET 18
P/O Figure 8-403. ABA3 and ABA4 10 MHz Reference Oscillator and Buffer Schematic





(U7A pin 3 jumpered to U6A pin 14)

P/O SERVICE SHEET 40
P/O Figure 8-539. A4A9 Modulation Drive Schematic
"AUX FM" Configured in the ON Position

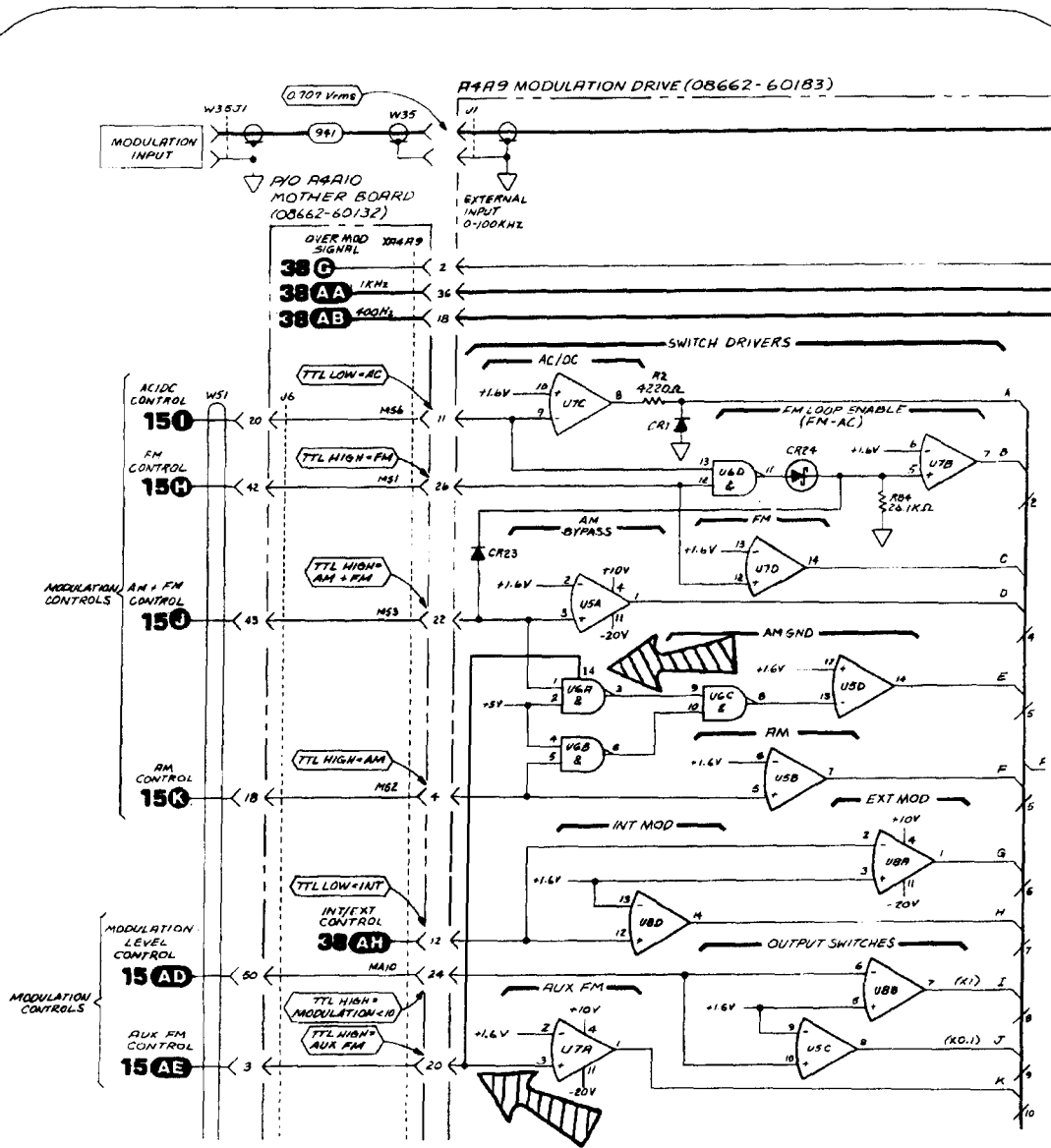

(U7A pin 3 jumpered to U6A pin 14)

P/O SERVICE SHEET 40
P/O Figure 8-539. A4A9 Modulation Drive Schematic
"AUX FM" Configured in the ON Position

**OPERATING AND SERVICE MANUAL
MODIFICATION**

MODEL 8662A

OPTION H17

SYNTHESIZED SIGNAL GENERATOR

How to Use This Insert

This Manual Modification Insert should be used in conjunction with the 8662A Operating and Service Manuals, Volumes 1 and 2, HP Part Number 08662-90069 (printed May 1990). Make the changes described in this Insert to the indicated sections of the Operating and Service Manuals.

Applicable Serial Numbers

This Manual Modification Insert applies to instruments with serial number prefixes greater than or equal to 2330A.

Updates to this Manual Insert

Periodically, changes are made to the Manual Insert to correct errors in the original printing and to include Option improvements. Corrections are indicated by a mark at the right-hand edge of the modified text. The mark used is keyed to the date the corrections are added (found on this cover below the issue date).

Manual Modification Insert
HP Part Number 08662-92035

Issued October 1983
Updated January 1985 *

INTRODUCTION

*

The 8662A Option H17 Synthesized Signal Generator has been modified to allow External Amplitude Modulation at carrier frequencies of less than 150 kHz. This Special AM Mode may be selected via the front panel or HP-IB. Internal battery-powered memory will retain the last mode selected even if line power is removed. Option H17 also changes the Auxiliary FM feature so that it cannot be controlled by Special Functions. The addition of Option H17 affects carrier output level accuracy below 150 kHz.

SECTION I, GENERAL INFORMATION

On page 1-2, in Section 1-5, under DESCRIPTION (Cont'd), change the following to read:

- * Keyboard control of all functions except Auxiliary FM.

On page 1-5, in Table 1-1, Specifications (2 of 5), under OUTPUT (cont'd), incorporate the following:

Electrical Characteristics	Performance Limits	Conditions
Absolute Level Accuracy (Below 150 kHz)	Not Specified	Carrier Frequency <150 kHz

On page 1-10, in Table 1-2, Supplemental Characteristics (2 of 2), add the following:

Electrical Characteristics	Typ. Performance	Conditions
SPECIAL AM MODE		0.02 to 0.15 MHz carrier freqs.
AM Depth	0 to 95%	Output level of +8 dBm and below
AM Rates Internal External	Not Operational 50 to 1500 Hz	<0.15 MHz 0 to 50% AM
AM Distortion	<3%	0 to 50% AM, 3 kHz BW, </=0 dBm
	<10%	0 to 90% AM, 3 kHz BW, </=0 dBm

On page 1-10, in Table 1-2, Supplemental Characteristics (2 of 2), under EXTERNAL MODULATION, add the following under Auxiliary FM Input:

Option H17 has been produced so that this function is hardwired in the "Off" position. An internal jumper wire must be moved in order to turn this input "On".

SECTION III, OPERATION

On page 3-2, in BASIC SIGNAL GENERATOR FUNCTIONS, under Modulation Signal, add the following:

For Special AM Mode below 150 kHz, Special Function 50 must be enabled. For normal 8662A operation above 150 kHz, Special Function 51 MUST be enabled.

On page 3-6, in Section 3-14, The STATUS key and light, between the first and second paragraphs, insert the following:

Special Function 51 MUST be enabled for normal 8662A operation above 150 kHz (with Option H17). (Special Function 51 will also provide normal 8662A operation below 150 kHz if desired).

On page 3-7 through 3-11, in the Getting Acquainted Exercise, change the INITIALIZING boxes to read:

INITIALIZING
Press the Blue Key, SPECIAL, and 00 to initialize the Generator to 100 MHz at -30 dBm, with Sweep and Special Functions off and Special AM Mode on. Then press the Blue key, SPECIAL, and 51 to turn the Special AM Mode off.

On page 3-11, in Section 3-22, Special Functions, change the third paragraph to read:

To change the AMPLITUDE readout from -30 dBm to 0.0 dB, press the Blue Key, SPECIAL, and 31. If you press the STATUS key, you'll see the special function code 31 on the left side of the FREQUENCY readout. (If special function 51 is enabled, the display will alternate between 31 and 51).

On page 3-12, in Figure 3-2, Readout Panel Features, under EXTERNAL SOURCE HI-LO, add the following:

When operating in the Special AM Mode below 150 kHz, the HI-LO enunciators will be inoperative.

On page 3-14, in Figure 3-4. Signal Generator Features, under MODULATION INPUT, add the following:

Special AM Mode below 150 kHz is selected by Special Function 50. Maximum AM rate at 20 kHz carrier is approximately 1.5 kHz. The Modulation Input requires approximately 7.6 mV RMS per 1% AM depth produced.

On page 3-31, in Table 3-4, HP-IB Message Reference Table, change the first sentence of the Clear Message Response to read:

Sets output to 100 MHz at -30 dBm with Sweep and Special Functions off and Special AM Mode on.

On page 3-43, in Section 3-53, under Modulation, replace the table in step 2 with the following:

Source Code	Modulation Modes	
	Internal (Rate)	External (Coupling)
48	----	Special AM Mode only (ac)
146	FM (1kHz)	----
148	AM (1kHz)	----
154	FM (1kHz)	AM (ac)
162	FM (400 Hz)	----
164	AM (400 Hz)	----
170	FM (400 Hz)	AM (ac)
176	OFF	OFF
178	----	FM (ac)
180	----	AM (ac)
218	FM (1kHz)	AM (dc)
234	FM (400 Hz)	AM (dc)
242	----	FM (dc)
244	----	AM (dc)

Source Codes of 128 and above enable Special Function 51 to turn off the Special AM Mode and allow normal 8662A operation above 150 kHz. Source Codes below 128 enable Special Function 50. To combine Special AM Mode with other modulation modes, subtract 128 from the desired modulation mode Source Code above. (Example: to use Special AM Mode concurrently with Internal FM at 1 kHz, the Source Code is 146-128=18).

On page 3-39, in Table 3-7, Response to Clear Message, add the following:

Parameter	Condition
Special AM Mode	On

On page 3-49, in Table 3-10, Special Function Codes, change to read:

Special Function	Code
AUX FM off	None
AUX FM on	None
Special AM Mode On	50
Special AM Mode off	51

On page 3-67, under Modulation, AM (Cont'd), add the following under Related Instructions:

Special AM Mode - refer to page 3-71 of Modulation, External Source.

On page 3-68, under Modulation, External Source, under Procedure; replace the last two paragraphs with the following:

The 8662A Option H17 deletes Special Function selection of the AUX FM INPUT. The instrument is shipped with the AUX FM INPUT hardwired in the "Off" position. The 8662A Option H17 retains the AUX FM INPUT capability but must be rewired for the "On" position.

NOTE

The above applies to all Special Function and HP-IB references concerning the AUX FM INPUT throughout the Operating and Service Manuals for the 8662A.

WARNING

Reconfiguration of jumper wires as described below should be performed only by service trained personnel who are aware of the possible hazards involved (for example; fire and electrical shock). Remove the power cord before removing the instrument covers. Also, both the personnel doing this reconfiguration and the work area being used must be static safeguarded to protect sensitive components from electrostatic discharge.

To enable the rear panel AUX FM INPUT, the jumper wire on the A4A9 Modulation Drive Assembly must be connected from pin 21 of the board's edge connector to pin 14 of A4A9U6A. See part of Figure 8-539 on page 15 of this Insert.

To disable the rear panel AUX FM INPUT, the jumper wire must be connected from pin 21 of the board's edge connector to pin 11 of A4A9U7A. See Figure 8-537A on page 8-522. (The instrument is factory-wired with AUX FM disabled).

On page 3-69, in Comments (Cont'd), under Greater Stability, replace the NOTE with the following:

NOTE

AM and FM is possible, with reduced stability, by using a second external source for FM and the rear panel AUX FM INPUT (enabled with a jumper on the A4A9 board).

On page 3-70, in Comments (Cont'd), replace the paragraph starting with "DC Coupling with Phase Lock" and the next paragraph with the following:

DC Coupling With Phase Lock. For external control of FM peak deviation (for signals entering the rear panel AUX FM INPUT):

- * Enable the AUX FM INPUT by performing the changes described in the preceding section titled Procedure on page 3-68.

On page 3-71, under Modulation, External Source (Cont'd), add the following:

Description Special AM Mode

External AM below 150 kHz can only be introduced via the Modulation Input jack. At the minimum carrier frequency of 20 kHz, the maximum AM rate is approximately 1500 Hz. For proper AM below 150 kHz, an output level of <+8 dBm should be maintained.

Procedure To enable Special AM Mode (designed for use below 150 kHz), press Special Function 50.

To disable Special AM Mode, press Special Function 51. Maintain this status for normal 8662A operation either above or below 150 kHz.

Keys and Program Codes	Keys		Codes (see note)		
	<HP-IB>	Blue Key SPECIAL	Special AM Mode ON	Special AM Mode OFF	SP 50 51

NOTE

If the 8662A is under HP-IB control, Special Function 51 must be programmed to provide normal operation.

Indications When using Special AM Mode, the EXTERNAL SOURCE HI-LO enunciators will be inoperative. Also, there is no normal front panel indication when the Special AM Mode is selected. Press the STATUS key: If "51" is not displayed at the left, the Special AM Mode is on.

Comments Certain components in the ALC circuitry of the 8662A have been changed for option H17. To allow External AM below 150 kHz, carrier output level accuracy was degraded. Therefore, output level accuracy is not specified during operation of the instrument from 10 kHz to 150 kHz carrier frequencies. Also note that normal 8662A AM will only operate accurately if Special AM Mode is disabled.

EXTERNAL CONTROL OF AM DEPTH

When using Special AM Mode below 150 kHz, only the level of the external modulating signal controls the AM depth. 720 mV RMS will provide approximately 95% AM depth. The sensitivity is approximately 1% AM per 7.6 mV RMS input.

On page 3-74, in the Modulation, Mixed section, delete the last line in Description: (Special Function 51).

On page 3-74, in Procedure, replace the lines labeled AUX FM On and Off with the following:

AUX FM ON: Refer to Procedure on page 3-68.
 AUX FM OFF: Shipped from factory in this configuration. Refer to Procedure on page 3-68 to change.

Change the second example on page 3-74 as follows:

Enable the rear panel AUX FM connector	
Local (Keystrokes)	Connect jumper on A4A9 board as described in Procedure, page 3-68
HP-IB (Program Codes)	Not applicable for the 8662A with Option H17

On page 3-75, replace the last sentence under Comments with the following:

The MOD OFF key turns off all modulation except FM produced from the AUX FM input and AM produced by the Special AM Mode.

On page 3-79, under SPECIAL FUNCTIONS, after Comments, add the following: *

When operating in the Special AM Mode, do not enter Special Functions 41 or 42. If these Special Functions are entered while using the Special AM Mode, their simultaneous operation will interfere with and distort the external modulation signal..

On page 3-80, change Table 3-11, Special Function, as follows:

Function	Codes*
AUXILIARY FM Off	None
AUXILIARY FM On	None
Special AM Mode On	50
Special AM Mode Off	51
All Special Functions Off (except 50 and 85)	80

On page 3-80, in Table 3-12, Initializing; Response to Special Function 00, change the table as follows:

Parameter	Condition
Modulation Mode	Special AM Mode enabled

On page 3-81, in Status, add the following at the end of the Comments Section:

If Special Function code "51" does not appear when the STATUS key is pressed, then Special AM Mode is on.

On page 3-82, in Table 3-14, Special Function Status Codes, change entry 51 to read:

51	Special AM Mode Off (normal 8662A operation enabled)
----	--

SECTION IV, PERFORMANCE TESTS

On page 4-9, in 4-6, the LEVEL ACCURACY AND FLATNESS TEST, and on page 4-12, in 4-7, the LEVEL ACCURACY TEST (OPTIONAL - LOW LEVEL), change the SPECIFICATION table as shown at the top of page 9 of this Insert.

Electrical Characteristics	Performance Limits	Conditions
Absolute Level Accuracy (1,2)	+/-1.0 dB	+13 to -120 dBm, >= 150 kHz
	+/-3.0 dB	-120 to -130 dBm, >= 150 kHz
Flatness (reference to 100 MHz, without correction, and down to -120 dBm)	+/-1.5 dB	150 kHz to 640 MHz
	+/-3.5 dB	150 kHz to 1280 MHz

SECTION VI, REPLACEABLE PARTS

In Table 6-3, Replaceable Parts, add or delete the following parts as noted:

Add or Del	Page No.	Ref Desig.	HP Part Number	Qty	Description
D	6-32	A4A1	08662-60126	1	Output Amplifier
A	6-32	A4A1	08662-62023	1	Output Amplifier (Option H17)
D	6-33	A4A1C47	0160-0576	1	Capacitor, Fixed, 0.1uF, 50V
A	6-33	A4A1C47	0160-0572	1	Capacitor, Fixed, 2200pF, 100V
D	6-46	A4A7	08662-60129	1	AGC Assembly
A	6-46	A4A7	08662-62024	1	AGC Assembly (Option H17)
D	6-47	A4A7C24	0180-2617	1	Capacitor, Fixed, 6.8uF, 35V
A	6-47	A4A7C24	0160-4741	1	Capacitor, Fixed, 0.22uF, 50V
D	6-50	A4A9	08662-60183	1	Modulation Drive Assembly
A	6-50	A4A9	08662-62025	1	Modulation Drive Assembly (Option H17)
A	6-51	A4A9MP98	0360-0124	2	Terminal Stud, Single Pin, Round Shank
A	6-51	A4A9MP99	0890-0099	A/R	Tubing, Flex, 0.025" ID
A	6-52	A4A9R201	0698-7268	1	Resistor, Fixed, 21.5kohm, 1%
A	6-52	A4A9R202	0698-7285	1	Resistor, Fixed, 110kohm, 1%

SECTION VIII, SERVICE

On page 8-513 (Service Sheet 35), replace part of Figure 8-518, P/O A4A1 Output Amplifier Schematic, with the partial schematic shown on page 11 of this Insert.

On page 8-517 (Service Sheet 37), replace part of Figure 8-524, A4A7 Output Section AGC Schematic, with the partial schematic shown on page 12 of this Insert.

On page 8-522 (Service Sheet 40), add Figure 8-537A from page 13 of this Insert.

On page 8-523/8-524 (Service Sheet 40), replace part of Figure 8-539, A4A9 Modulation Drive Schematic, with the partial schematic on page 14 of this Insert.

For information on enabling the AUX FM INPUT, refer to the partial Schematic on page 15 of this Insert.

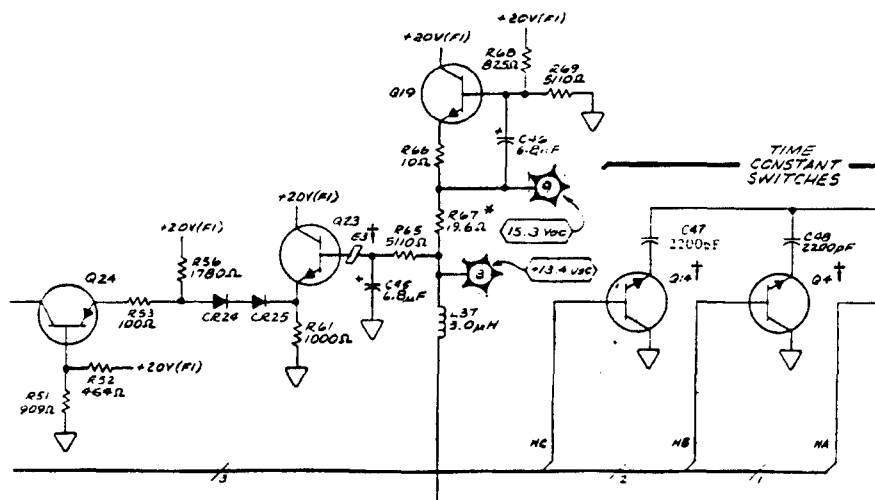

PART OF SERVICE SHEET 35.
PART OF FIGURE 8-518.
P/O A4A1 Output Amplifier Schematic

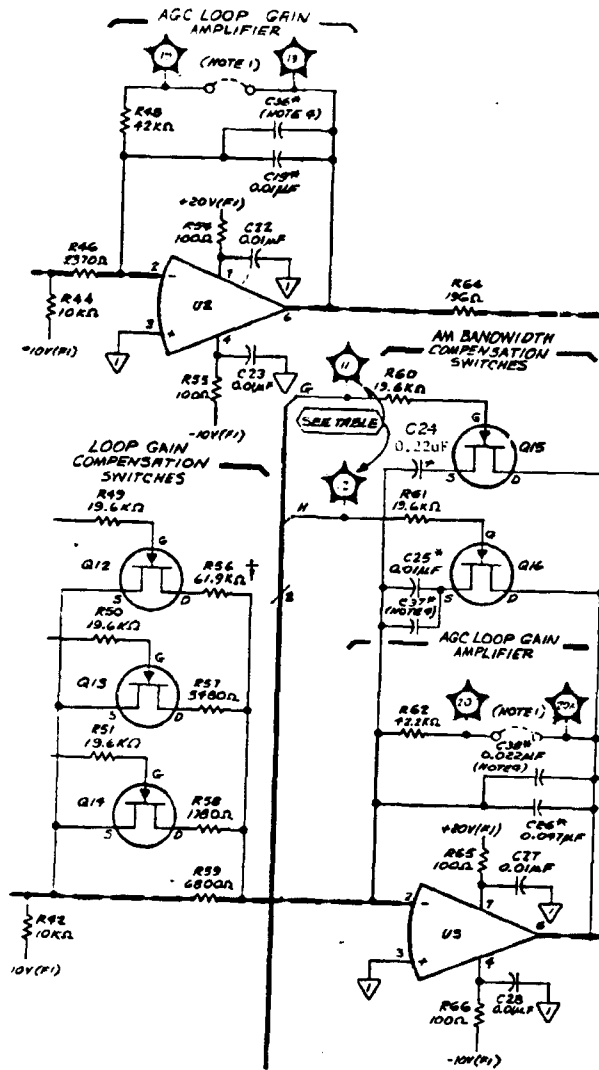

PART OF SERVICE SHEET 37.
 PART OF FIGURE 8-524.
 A4A7 output Section AGC Schematic

A4A9 ASSEMBLY

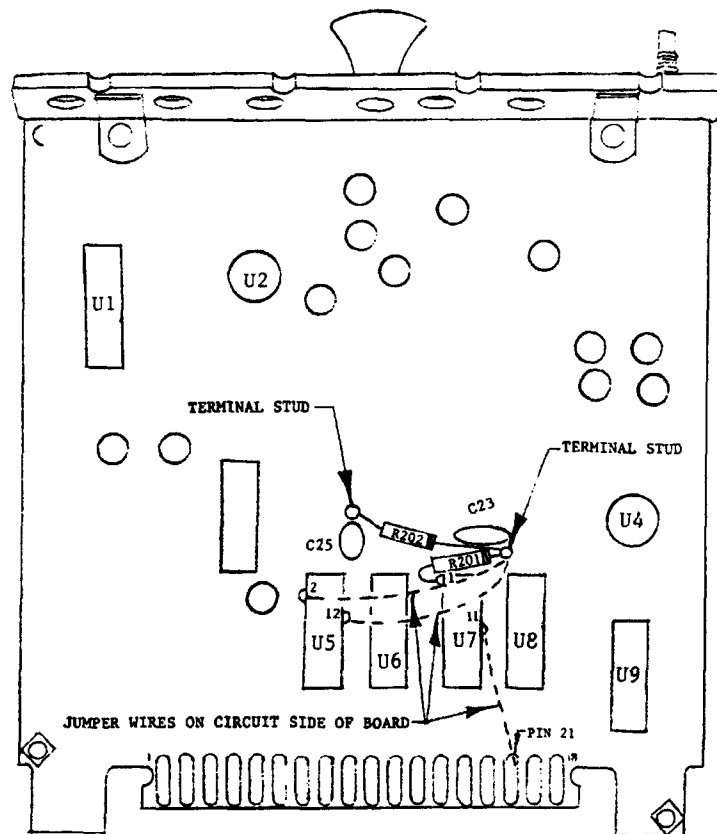
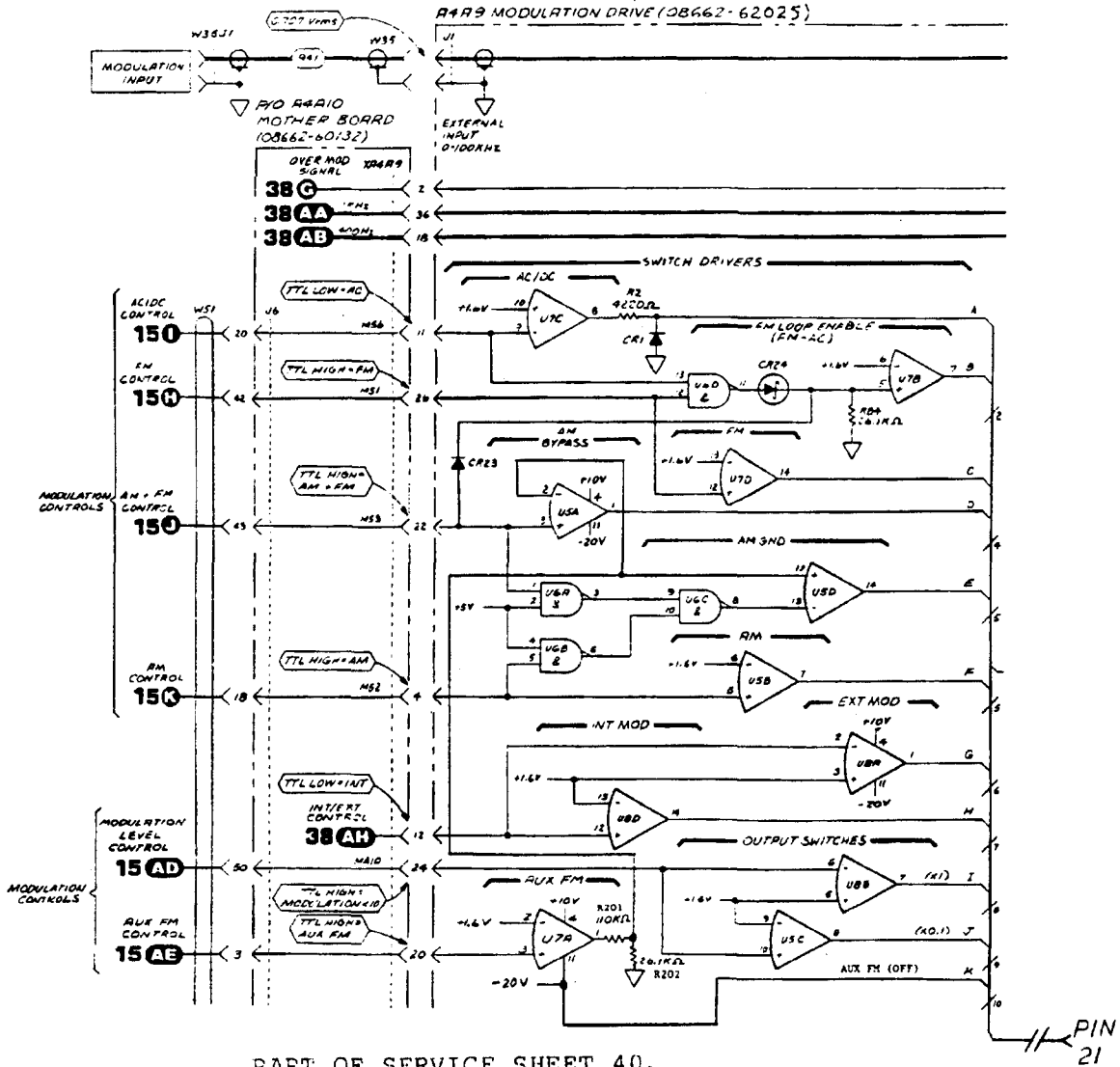
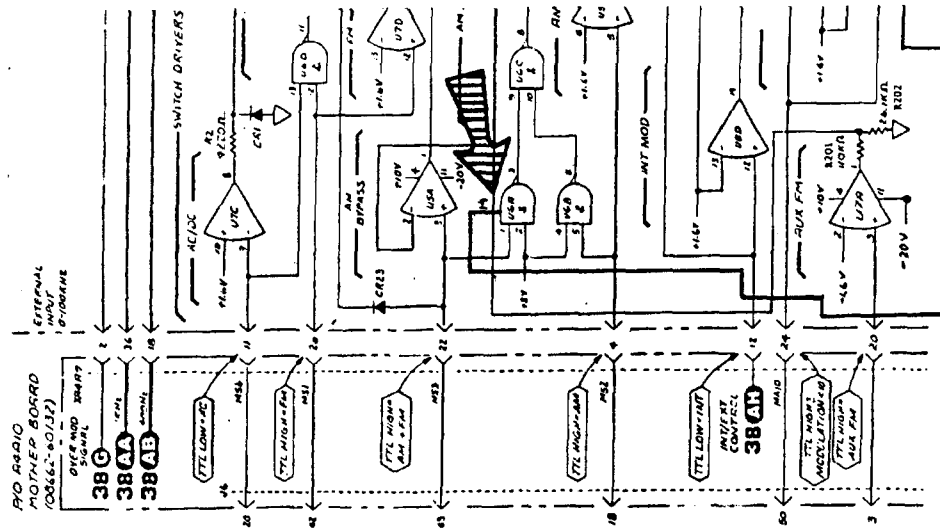

Figure 8-537A.
Fictorial View of Modified A4A9 Board



PART OF SERVICE SHEET 40.
 PART OF FIGURE 8-539.
 A4A9 Modulation Drive Schematic



P/O Service Sheet 40, showing "AUX FM" configured in the ON position.

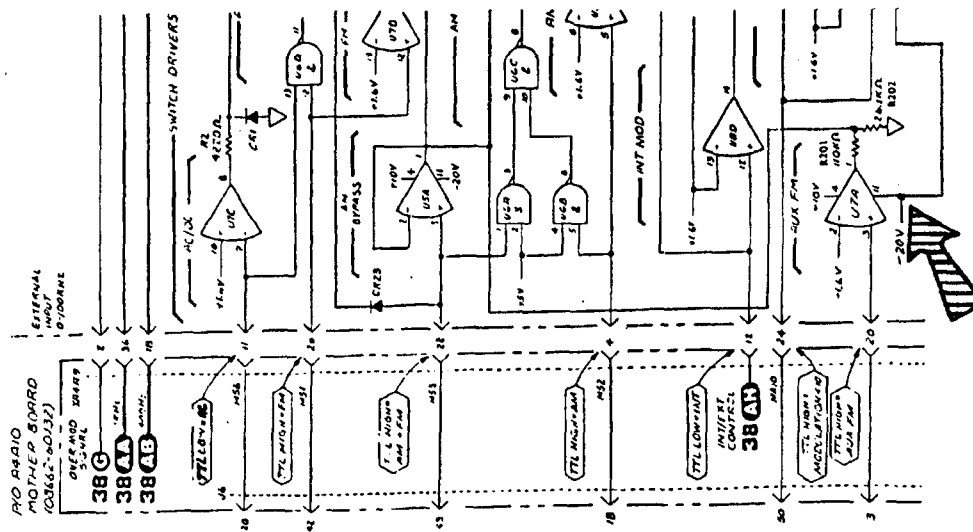

P/O Service Sheet 40, showing "AUX FM" configured in the OFF position.

PART OF FIGURE 8-539. A4A9 MODULATION DRIVE SCHEMATIC

**OPERATING AND SERVICE MANUAL
MODIFICATION**

MODEL 8662A

OPTION H18

SYNTHESIZED SIGNAL GENERATOR

How to Use This Insert

This Manual Modification Insert should be used in conjunction with the 8662A Operating and Service Manuals, Volumes 1 and 2, HP Part Number 08662-90069 (printed May 1990). Make the changes described in this Insert to the indicated sections of the Operating and Service Manuals.

Applicable Serial Numbers

This Manual Modification Insert applies to instruments with serial number prefixes greater than or equal to 2340A.

Updates to this Manual Insert

Periodically, changes are made to the Manual Insert to correct errors in the original printing and to include Option improvements. Corrections are indicated by a mark at the right-hand edge of the modified text. The mark used is keyed to the date the corrections are added (found on this cover below the issue date).

Manual Modification Insert
HP Part Number 08662-92033

Issued September 1983

SECTION I. GENERAL INFORMATION

Option H18 to the HP Model 8662A Synthesized Signal Generator provides an 8662A selected for single-sideband phase noise better than the standard specifications. Option H03 (which provides a rear-panel 640 MHz low-noise output) must be ordered with Option H18. All single-sideband phase noise measurements are defined and guaranteed as measured on an HP 3047A Spectrum Analyzer System with suitable low-noise local oscillators. Because of the nature of these noise measurements, no allowance has been included in the Option H18 specifications for the uncertainty of the 3047A measurements or any uncertainty caused by temperature or other environmental variations.

On page 1-4, in Table 1-1, Specifications (1 of 5), under SPECTRAL PURITY, replace the section titled Residual SSB Phase Noise in 1 Hz Bandwidth with the following:

Part of Table 1-1. Specifications

Electrical Characteristics	Performance Limits	Conditions
SSB Phase Noise in a 1 Hz Bandwidth (Main RF Output)		320 to 639.9 MHz; CW or AM mode only
Residual Noise of 8662A without noise contribution of 10811A Reference	-100 dBc -112 dBc	10 Hz offset from carrier 100 Hz offset from carrier
Absolute Noise of 8662A and 10811A Reference	-125 dBc -136 dBc -136 dBc	1 kHz offset from carrier 10 kHz offset from carrier 100 kHz offset from carrier
SSB Phase Noise in a 1 Hz Bandwidth (640 MHz Output of Option H03)		640 MHz; CW or AM mode only
	-126 dBc -149 dBc -159 dBc	1 kHz offset from carrier 10 kHz offset from carrier 100 kHz offset from carrier

Since the 8662A Option H18 is factory-selected to meet more stringent specifications, repair, replacement, and/or adjustment of critical parts and assemblies could degrade performance back to standard specifications. Under these conditions, Hewlett-Packard's warranty obligation would be to the standard specifications, not to the Option H18 specifications. For these reasons, Hewlett-Packard recommends that the 8662A Option H18 be returned to the factory for any repairs or adjustments which may affect phase noise performance.

On page 1-13, add the following to Table 1-3, Recommended Test Equipment (3 of 3):

Instrument	Critical Specification	Rec. Model	Use
Spectrum Analyzer System	System Phase Noise: -160 dBc @ 1 kHz -170 dBc @ 10 kHz -170 dBc @ 100 kHz	HP 3047A REQUIRED; NO KNOWN SUBSTITUTES	P

SECTION IV, PERFORMANCE TESTS

On page 4-15, in 4-8, the SSB PHASE NOISE TEST, in the SPECIFICATION table, replace the section titled Residual SSB Phase Noise in 1 Hz Bandwidth with the partial Table 1-1 on page 1 of this Insert. Also, add the following under DESCRIPTION: "The following test procedure may be used as a general performance check of the phase noise of Option H18. However, since Option H18 is defined as being tested on an HP 3047A Spectrum Analyzer System, only this System (and suitable low-noise local oscillators) should be used to verify the performance of Option H18."

On page 4-17, in 4-9, SSB PHASE NOISE TEST (OPTIONAL), in the SPECIFICATION table, replace the section titled Residual SSB Phase Noise in 1 Hz Bandwidth with the partial Table 1-1 on page 1 of this Insert. Also, add the following under DESCRIPTION: "The following test procedure may be used as a general performance check of the phase noise of Option H18. However, since Option H18 is defined as being tested on an HP 3047A Spectrum Analyzer System, only this System (and suitable low-noise local oscillators) should be used to verify the performance of Option H18."

SECTION V, ADJUSTMENTS

Certain adjustments, such as 5-8, the 40 MHz CRYSTAL FILTER ADJUSTMENT, directly affect the phase noise of the 8662A. Other adjustments, such as 5-9, 5-10, and 5-11, can indirectly affect the phase noise of the main RF Output. Therefore, use caution when making any adjustments on Option H18, and verify phase noise performance after making any such adjustments. Refer to the first paragraph at the top of page 2 of this Insert for further information.

SECTION VI, REPLACEABLE PARTS

In Table 6-3, Replaceable Parts, add or delete parts as noted in the following table:

Add or Del	Page No.	Ref. Desig.	HP Part Number	Qty	Description
D	6-91	A8A3	10811A	1	10 MHz Reference Oscillator
A	6-91	A8A3	08662-82008	1	10811A 10 MHz Reference Oscillator, selected for low noise

SECTION VIII, SERVICE

Before proceeding with repair, replacement, or adjustment of parts or assemblies of Option H18, refer to the first paragraph at the top of page 2 of this Insert.

On page 8-102, under paragraph 8-18, Factory Selected Components (*), incorporate the following:

The 8662A Option H18 includes a Factory-selected A8A3 10 MHz Reference Oscillator to insure guaranteed phase noise performance. If it is necessary to replace A8A3, use a factory-tested replacement part (see Table 6-3) or a 10811A with low enough noise to provide Option H18 performance when tested in the 8662A. Typically, the 10811A 10 MHz output must have SSB phase noise of approximately -162 dBc at a 1 kHz offset.

**OPERATING AND SERVICE MANUAL
MODIFICATION**

MODEL 8662A

OPTION H21

SYNTHESIZED SIGNAL GENERATOR

How to Use This Insert

This Manual Modification Insert should be used in conjunction with the 8662A Operating and Service Manuals, Volumes 1 and 2, HP Part Number 08662-90069 (printed May 1990). Make the changes described in this Insert to the indicated sections of the Operating and Service Manuals.

Applicable Serial Numbers

This Manual Modification Insert applies to instruments with serial number prefixes greater than or equal to 2450A.

Updates to this Manual Insert

Periodically, changes are made to the Manual Insert to correct errors in the original printing and to include Option improvements. Corrections are indicated by a mark at the right-hand edge of the modified text. The mark used is keyed to the date the corrections are added (found on this cover below the issue date).

Manual Modification Insert
HP Part Number 08662-92037

Issued May 1984
Updated October 1984 *
Updated January 1985 #
Updated June 1986 ✓
Updated March 1988 @

*#@

SECTION I. GENERAL INFORMATION

Option H21 to the HP Model 8662A Synthesized Signal Generator provides an 8662A factory-selected for single-sideband (SSB) phase noise from the 640 MHz output better than the specifications of Option 003. Option 003 provides guaranteed SSB phase noise from the 640 MHz low-noise output (Option 003 must be ordered with Option H21.)

All SSB phase noise measurements from the 640 MHz output are defined and guaranteed as measured on an HP 3048A Phase Noise Measurement System with suitable low-noise local oscillators. Because of the nature of these measurements, no allowance has been included in the Option H21 specifications for the uncertainty of the 3048A measurements (typically +/-2dB) or any uncertainty caused by temperature, vibration, or other environmental variations.

@

@

On page 1-4, in Table 1-1, Specifications (1 of 5), under SPECTRAL PURITY, add the following after the section titled "Residual SSB Phase Noise in 1 Hz Bandwidth":

Electrical Characteristics	Performance Limits	Conditions	
SSB Phase noise in a 1 Hz Bandwidth (640 MHz Output of Option H21)		640 MHz; Sweep Mode Disabled	
Absolute Noise of the 640 MHz Output (including the noise contribution of the 10811-60111 Reference)	-62dBc -92dBc -117dBc -126dBc -147dBc -157dBc -157dBc	1 Hz Offset from carrier 10 Hz Offset from carrier 100 Hz Offset from carrier 1 kHz Offset from carrier 10 kHz Offset from carrier 100 kHz Offset from carrier 1 MHz Offset from carrier	#

NOTE

Since the 8662A Option H21 is factory-selected to meet more stringent specifications, any field repair, replacement, and/or adjustment of critical parts and assemblies could upgrade performance back to standard specifications. Under these conditions, Hewlett-Packard's warranty obligation would be to the standard specifications, not to the Option H21 specifications. For these reasons, Hewlett-Packard recommends that the 8662A Option H21 be returned to the factory for any repairs or adjustments which may affect phase noise performance. Factory repair provides Option H21 specifications and is warranted.

*

@

On page 1-13, add the following to Table 1-3, Recommended Test Equipment (3 of 3):

Instrument	Critical Specifications	Rec. Model	USE
Spectrum Analyzer System	System Phase Noise: -160 dBc @ 1 kHz -170 dBc @ 10 kHz -170 dBc @ 100 kHz	HP 3048A or HP 3047A	P @

SECTION III. OPERATION

Option H21 is designed to provide an 8662A with very low 640 MHz-output phase noise. To preserve this performance, the user should isolate the 8662A from sources of vibration and acoustic noise as much as possible. These disturbances may cause microphonic spurious responses on the output. One possible way to minimize external vibration coupled to the 8662A is to place the instrument on a foam pad.

Also, note that the 8662A itself produces power-line related spurious signals, as well as fan-generated microphonic spurious signals on its output signal. These spurious signals are not included in Option H21 specifications.

SECTION IV. PERFORMANCE TESTS

On pages 4-25a through 4-25f, replace all references to "(Option 003 only)" with "(Option 003/H21 only)".

On page 4-25a, in 4-12, ABSOLUTE SSB PHASE NOISE ON REAR PANEL 640 MHZ OUTPUT (Option 003/H21 only), replace the table under SPECIFICATION with the table at the top of page 3 of this Insert.

@

Electrical Specifications	Performance Limit	Conditions
<p style="text-align: center;">SPECTRAL PURITY</p> <p>Absolute SSB Phase Noise on rear panel 640 MHz output</p> <p>Output Level of rear panel 640 MHz output</p>	<p style="text-align: center;">-67 dBc -92 dBc -117 dBc -126 dBc -145 dBc -157 dBc -157 dBc</p> <p style="text-align: center;">> +1 dBm</p>	<p style="text-align: center;">1 Hz measurement Bandwidth</p> <p style="text-align: center;"><u>Offset from carrier</u></p> <p style="text-align: center;">1 Hz 10 Hz 100 Hz 1 kHz 10 kHz 100 kHz 1 Mhz</p>

Also, on page 4-25a, in 4-12, add the following under DESCRIPTION:

The following test procedure may be used as a general performance check of the phase noise of Option H21. However, since Option H21 is defined as being tested on an HP 3048A Phase Noise Measurement System, only this System or a 3047A Spectrum Analyzer System (and suitable low-noise local oscillators) should be used to verify the performance of Option H21.

On page 4-25f, in 4-12, ABSOLUTE SSB PHASE NOISE ON REAR PANEL 640 MHZ OUTPUT (Option 003/H21 only) (cont'd), replace the table with the table at the top of page 4 of this Insert.

#✓@

-----MEASURED NOISE-----				
Offset	Relative to Reference Level (dB/Hz)	Correction	Total (dBc/Hz)	Limit (dBc/Hz)
10 Hz	_____	-59 dB	_____	-97
100 Hz	_____	-59 dB	_____	-117
1 kHz	_____	-59 dB	_____	-126
10 kHz	_____	-59 dB	_____	-147
100 kHz	_____	-59 dB	_____	-157
1 MHz	_____	-59 dB	_____	-157

SECTION V. ADJUSTMENTS

Certain adjustments, such as 5-8, the 40 MHz CRYSTAL FILTER ADJUSTMENT, directly affect the phase noise of the 8662A. Therefore, use caution when making any adjustments on Option H21, and verify phase noise performance after making any such adjustments. Refer to the NOTE at the bottom of page 1 of this Insert for further information.

SECTION VI. REPLACEABLE PARTS

In Table 6-3, Replaceable Parts, add or delete the following parts as noted:

Add or Del	Page No.	Refer. Desig.	HP Part Number	Qty	Description
D	6-90	A8A3	10811-60111	1	10 MHz Reference Oscillator
A	6-90	A8A3	10811-60209	1	10 MHz Reference Oscillator selected for low noise
A		----	0515-0089	4	Scr-Mach M5 x 0.8 16mm-LG FLPD
A		----	0515-0107	8	Scr-Mach M4 x 0.7 12mm-LG PNPD
A		----	0515-0265	4	Scr-Mach M4 x 0.7 12mm-LG FLPD

#

SECTION VIII. SERVICE

Before proceeding with repair, replacement, or adjustment of parts or assemblies of Option H21, refer to the **NOTE** on page 1 of this Insert.

On page 8-104, under paragraph 8-18, Factory Selected Components (*), incorporate the following:

The 8662A Option H21 includes a factory-selected A8A3 10 MHz Reference Oscillator to insure guaranteed phase noise performance. If it is necessary to replace A8A3, use a factory-tested replacement part (see Table 6-3) or an HP P/N 10811-60111 with low enough noise to provide Option H21 performance when tested in the 8662A. Typically, the 10811-60111 10 MHz output must have SSB phase noise of approximately -162 dBc at a 1 kHz offset.

**OPERATING AND SERVICE MANUAL
MODIFICATION**

MODEL 8662A

OPTION H25

SYNTHESIZED SIGNAL GENERATOR

How to Use This Insert

This Manual Modification Insert should be used in conjunction with the 8662A Operating and Service Manual, Volume I and Volume II (HP Part Number 08662-90069), both printed May 1990. Make the changes described in this Insert to the indicated Sections of the Operating and Service Manuals.

Applicable Serial Numbers

This Manual Modification Insert applies to instruments with serial number prefixes greater than 2424A.

Updates to this Manual Insert

Periodically, changes are made to the Manual Insert to correct errors in the original printing and to include Option improvements. Corrections are indicated by a mark at the right-hand edge of the modified text. The mark used is keyed to the date corrections are added (found on this cover below the issue date).

Manual Modification Insert
HP Part Number 08662-92039

Issued November 1984
Updated November 1986
Updated August 1994

SECTION I. GENERAL INFORMATION

Copyright 1986 -- HEWLETT-PACKARD COMPANY -- Spokane Division
24001 E. Mission Ave, Liberty Lake, WA 99019-9599 U.S.A.

Option H25 to the 8662A Synthesized Signal Generator provides direct control of the frequencies output from the phase lock loops via a rear-panel mounted, 25-pin, parallel input port. This is referred to as the Direct Frequency Access (DFA) port. The 8662A will respond to a specialized 17-bit parallel data format resulting in frequencies in the 30.0 to 100.5 MHz range when in the DFA mode.

SECTION II. INSTALLATION

On page 2-3, add the following at the end of the Section 2-8, Mating Connectors.

Direct Frequency Access Connector. Interconnection data for the parallel input port is provided in Figure 2-4 on page 9 of this Insert.

At the top of page 2-6, insert Figure 2-4, found on page 9 of this Insert.

SECTION III. OPERATION

On page 3-1, add the following at the end of Section 3-4, Remote Operation:

DIRECT FREQUENCY ACCESS (DFA). Option H25 provides remote control of the frequency output from the phase lock loops. This control results in an RF frequency output in the 30.0 to 100.5 MHz range. Operation of the 8662A Option H25 in the DFA mode is described in the Direct Frequency Access paragraph on page 3-49. DFA mode allows rapid frequency switching, sometimes referred to as frequency-hopping.

On page 3-17, replace part of Figure 3-7, Rear Panel Features, with the partial Figure 3-7, Rear Panel Features (Option H25), on page 10 of this Insert.

On page 3-49, add sections 3-54, 3-55 and 3-56 and Tables 3-11 and 3-12 at the bottom of the page:

3-54. REMOTE OPERATION, DIRECT FREQUENCY ACCESS

3-55. DFA MODE

Option H25 gives the 8662A the capability to switch rapidly between frequencies predetermined by the user utilizing a specialized 17-bit parallel-format input to the rear-panel DFA connector. Tables 3-11 and 3-12 describe the parallel format used. This DFA format operates correctly only over the RF frequency range of 30.0 to 100.5 MHz. The minimum frequency increment for DFA mode is 5 kHz.

- 3-56. The following procedure describes the setup and operation of the 8662A Option H25 in the DFA mode.

CAUTION

Pins 1 through 15 and 19 on the DFA connector accommodate positive-true (1) CMOS logic levels. Since these lines drive CMOS gates, they are static sensitive. Connection and/or removal of plugs to the rear-panel DFA connector should be performed with the 8662A turned off or unplugged.

1. Turn the 8662A on. Set the desired modulation and output levels, and any RF frequency in the range from 10 to 119.99 MHz. This may be done manually or via HP-IB.
2. Refer to Figure 2-4 and Tables 3-11 and 3-12 for descriptions of the parallel format unitized with Option H25 as well as the logic levels required on each pin of the DFA connector.
3. Enable the DFA mode by applying a negative-true (1) TTL logic level to pin 18 (HOPEN) of the DFA connector.
4. 30 MHz is the DFA reference frequency from which other output frequencies are determined. To program the 30 MHz reference frequency, apply logical levels to inputs B0 through B16 (pins 1 through 17 of the DFA connector).
5. Data present at the DFA input is latched onto the frequency data lines following a positive-going CMOS level transition at the DATSTRB input (pin 19). To determine the next output frequency (following the next positive transition on the DATSTRB line), total the frequency offsets of bits 3 to 16 that have true logic levels applied to them (from Table 3-11). Add this total to 30.0 MHz. Then determine the frequency offset from bits 0 to 2 from Table 3-12 and add this total to the previous total.

Example: Only bits 2, 4, 5, 8, 11 and 13 have logic true (1) levels applied. To determine the output frequency, add the frequency offsets of bits 4, 5, 8, 11 and 13 to 30.0 MHz:

$$0.05 + 0.1 + 0.8 + 6.4 + 25.6 + 30.0 = \underline{62.95 \text{ MHz}}$$

To this total, add the frequency offset for bit 2 true and bits 0 and 1 false:

$$62.95 \text{ MHz} + (-0.005 \text{ MHz}) = \underline{62.945 \text{ MHz}}$$

6. To disable the DFA mode, apply a TTL false level to pin 18 (HOPEN) of the DFA connector. The RF frequency should return to the same frequency set prior to enabling the DFA mode.

NOTE

When operating the 8662A in the DFA mode, the front panel will not display the actual RF output frequency. The front-panel will display the frequency that the 8662A was set to prior to enabling the DFA mode. When DFA mode is not enabled, the instrument functions normally.

Table 3-11. DFA Connector Functions

DFA Input Pin No.	Freq. Bit	Function	Frequency Offset	Description
1	0	Frequency Offset	See Table 3-12.	Pos-true (1) CMOS logic level
2	1	Frequency Offset	See Table 3-12.	Pos-true (1) CMOS logic level
3	2	Frequency Offset	See Table 3-12.	Pos-true (1) CMOS logic level
4	3	Frequency Offset	+0.025 MHz	Pos-true (1) CMOS logic level
5	4	Frequency Offset	+0.05 MHz	Pos-true (1) CMOS logic level
6	5	Frequency Offset	+0.1 MHz	Pos-true (1) CMOS logic level
7	6	Frequency Offset	+0.2 MHz	Pos-true (1) CMOS logic level
8	7	Frequency Offset	+0.4 MHz	Pos-true (1) CMOS logic level
9	8	Frequency Offset	+0.8 MHz	Pos-true (1) CMOS logic level
10	9	Frequency Offset	+1.6 MHz	Pos-true (1) CMOS logic level
11	10	Frequency Offset	+3.2 MHz	Pos-true (1) CMOS logic level
12	11	Frequency Offset	+6.4 MHz	Pos-true (1) CMOS logic level
13	12	Frequency Offset	+12.8 MHz	Pos-true (1) CMOS logic level
14	13	Frequency Offset	+25.6 MHz	Pos-true (1) CMOS logic level
15	14	Frequency Offset	+51.2 MHz	Pos-true (1) CMOS logic level
16	15	Frequency Offset	+7.0 MHz	Neg-true (1) TTL logic Level
17	16	Frequency Offset	+12.5 MHz	Neg-true (1) TTL logic Level
18	---	HOPEN	----	Enable fast-hop mode with neg-true (1) TTL logic level
19	---	DATSTRB	----	Latches data onto frequency data lines on receipt of CMOS pos-true (1) edge trigger
20-24	---	---	----	Not connected
25	---	GND	----	DFA connector chassis ground

Table 3-12. Logic Levels Required for Small Frequency Offsets.

DFA Input Pin No.	Frequency Bit	Frequency Offset				
		-0.01 MHz	-0.005 MHz	0 MHz	+0.005 MHz	+0.01 MHz
Logical State (0 = false, 1 = true)						
1	0	1	0	1	0	1
2	1	1	0	0	1	1
3	2	0	1	1	1	1

SECTION VI. REPLACEABLE PARTS

In Table 6-3, Replaceable Parts, add or delete the following parts as noted:

Table 6-3. Replaceable Parts

Add or Del	Page No.	Refer. Desig.	HP Part Number	Qty	Description
D	6-11	A2A4	08662-60167	1	Frequency Output Board Assembly (Delete all reference designators under A2A4)
A	6-11	A2A4	08662-62035	1	Frequency Output/Direct Frequency Access Assembly
A	6-11	A2A4MP1	2360-0199	4	SCR-MACH 6-32 .438" ID PAN-HD-POZI
A	6-11	A2A4MP4	2190-0018	4	WASHER-LK HLCL #6 .141" ID
A	6-11	A2A4A1	08662-62033	1	Frequency Output Board Assembly
A	6-11	A2A4A1C1	0180-0197	1	Cap-Fxd 2.2uF +/-10% 20Vdc TA
A	6-11	A2A4A1C2	0180-0197	1	Cap-Fxd 2.2uF +/-10% 20Vdc TA
A	6-11	A2A4A1C3	0180-0197	1	Cap-Fxd 2.2uF +/-10% 20Vdc TA
A	6-11	A2A4A1C4	0180-0197	1	Cap-Fxd 2.2uF +/-10% 20Vdc TA
A	6-11	A2A4A1C5	0180-0197	1	Cap-Fxd 2.2uF +/-10% 20Vdc TA
A	6-11	A2A4A1MP1	4040-0748	1	EXTR-PC BD BLK POLYO .062-BD-THKNS
			1480-0073	1	PIN-ROLL .062" DIA .25" LG BE-CU
A	6-11	A2A4A1MP2	4040-0752	1	EXTR-PC BD YEL POLYC .062-BD-THKNS
			1480-0073	1	PIN-ROLL .062" DIA .25" LG BE-CU
A	6-11	A2A4A1MP6	08662-82016	30	CONN-PIN BERG 76159-028
A	6-11	A2A4A1R1	0757-0442	1	RESISTOR 10K 1% 0.125W F TC=0+/-100
A	6-11	A2A4A1R2	0757-0442	1	RESISTOR 10K 1% 0.125W F TC=0+/-100
A	6-11	A2A4A1R3	0757-0442	1	RESISTOR 10K 1% 0.125W F TC=0+/-100
A	6-11	A2A4A1R4	1810-0279	1	RESISTOR-PACK 4.7K 2%
A	6-11	A2A4A1R5	0757-0401	1	RESISTOR 100 1% 0.125W F TC=0+/-100
A	6-11	A2A4A1U1	1820-1730	1	IC FF TTL LS D-TYPE POS-EDG-TRG COM
A	6-11	A2A4A1U2	1820-1997	1	IC FF TTL LS D POS-EDGE-TRIG PL-IN
A	6-11	A2A4A1U3	1820-1267	1	IC CONV TTL BCD-TO-BIN 6-BIT
A	6-11	A2A4A1U4	1820-1997	1	IC FF TTL LS D POS-EDG-TRG PL-IN
A	6-11	A2A4A1U5	1820-1433	1	IC SHF-RGTR TTL LS RS SER-IN PL-OUT
A	6-11	A2A4A1U6	1820-1433	1	IC SHF-RGTR TTL LS RS SER-IN PL-OUT
A	6-11	A2A4A1U7	1820-1794	1	IC BFR TTL LS NON-INV OCTL
A	6-11	A2A4A1U8	1820-1794	1	IC BFR TTL LS NON-INV OCTL
A	6-11	A2A4A1U9	1820-1794	1	IC BFR TTL LS NON-INV OCTL
A	6-11	A2A4A1U10	1820-1794	1	IC BFR TTL LS NON-INV OCTL
A	6-11	A2A4A1U11	1820-1794	1	IC BFR TTL LS NON-INV OCTL
A	6-11	A2A4A1U12	1820-1794	1	IC BFR TTL LS NON-INV OCTL
A	6-11	A2A4A1U13	1820-1433	1	IC SHF-RGTR TTL LS RS SER-IN PL-OUT
A	6-11	A2A4A1U14	1820-1433	1	IC SHF-RGTR TTL LS RS SER-IN PL-OUT
A	6-11	A2A4A1U15	1820-1433	1	IC SHF-RGTR TTL LS RS SER-IN PL-OUT

Table 6-3. Replaceable Parts (Cont'd)

Add or Del	Page No.	Refer. Desig.	HP Part Number	Qty	Description
A	6-11	A2A4A1U16	1820-1730	1	IC FF TTL LS D-TYPE POS-EDG-TRG COM
A	6-11	A2A4A1U17	1820-1730	1	IC FF TTL LS D-TYPE POS-EDG-TRG COM
A	6-11	A2A4A1U18	1820-1730	1	IC FF TTL LS D-TYPE POS-EDG-TRG COM
A	6-11	A2A4A1U19	1820-1267	1	IC CONV TTL BCD-TO-BIN 6-BIT
A	6-11	A2A4A1U20	1820-1997	1	IC FF TTL LS D POS-EDG-TRG PL-IN
A	6-11	A2A4A1U21	1820-1433	1	IC SHF-RGTR TTL LS RS SER-IN PL-OUT
A	6-11	A2A4A1U22	1820-1433	1	IC SHF-RGTR TTL LS RS SER-IN PL-OUT
A	6-11	A2A4A1U23	1820-1433	1	IC SHF-RGTR TTL LS RS SER-IN PL-OUT
A	6-11	A2A4A2	08662-62032	1	DIRECT FREQUENCY ACCESS BOARD ASSY.
A	6-11	A2A4A2C1	0160-0576	1	CAP-FXD 0.1uF +/-20% 50VDC CER
A	6-11	A2A4A2C2	0160-0576	1	CAP-FXD 0.1uF +/-20% 50VDC CER
A	6-11	A2A4A2MP1	0380-0156	4	STANDOFF-RVT-ON 0.375" LG 6-32-THD
A	6-11	A2A4A2P1	1251-5650	1	CONN POST TYP 0.100-PIN-SPCG 26-CNT
A	6-11	A2A4A2P2	08662-82015	1	CONN AMP 1-86418-0
A	6-11	A2A4A2R1	1810-0207	1	NETWORK-RES 8-SIP 22.0Kx7
A	6-11	A2A4A2R2	1810-0207	1	NETWORK-RES 8-SIP 22.0Kx7
A	6-11	A2A4A2R3	0757-0442	1	RES-FXD 10K 1% 0.125W F TC=+/-100
A	6-11	A2A4A2R4	0757-0442	1	RES-FXD 10K 1% 0.125W F TC=+/-100
A	6-11	A2A4A2R5	0757-0199	1	RES-FXD 21.5K 1% 0.125W F TC=+/-100
A	6-11	A2A4A2R6	0757-0199	1	RES-FXD 21.5K 1% 0.125W F TC=+/-100
A	6-11	A2A4A2R7	0757-0442	1	RES-FXD 10K 1% 0.125W F TC=+/-100
A	6-11	A2A4A2U1	1820-1997	1	IC FF TTL LS D POS-EDG-TRG PL-IN
A	6-11	A2A4A2U2	1820-1997	1	IC FF TTL LS D POS-EDG-TRG PL-IN
A	6-11	A2A4A2U3	1820-1997	1	IC FF TTL LS D POS-EDG-TRG PL-IN
A	6-11	A2A4A2U4	1820-2024	1	IC DRVR TTL LS LINE-DRVR OCTEL
A	6-11	A2A4A2U5	1820-2024	1	IC DRVR TTL LS LINE-DRVR OCTEL
A	6-11	A2A4A2U6	1820-2024	1	IC DRVR TTL LS LINE-DRVR OCTEL
A	6-11	A2A4A2U7	08662-82010	1	DFA ROM #1, Option H25
A	6-11	A2A4A2U8	08662-82011	1	DFA ROM #2, Option H25
A	6-11	A2A4A2U9	08662-82012	1	DFA ROM #3, Option H25
A	6-11	A2A4A2U10	1820-1146	1	IC BFR CMOS NON-INV HEX
A	6-11	A2A4A2U11	1820-1146	1	IC BFR CMOS NON-INV HEX
A	6-11	A2A4A2U12	1820-1146	1	IC BFR CMOS NON-INV HEX
A	6-11	A2A4A2U13	1820-1199	1	IC INV TTL LS HEX 1-INP
D	6-15	A2MP2	08662-00046	1	Cover, DCU, Left
A	6-15	A2MP2	08662-02033	1	Cover, DFCU, Left, Option H25
A	6-95	J25	-----	1	P/O W64, (Not separately replaceable)
A			1251-2942	1	Connector screw lock kit
				2	
				2	
D	6-101	MP105	08862-00011	1	Cover, Transformer
A	6-101	MP105	08662-02029	1	Cover, Transformer, Option H25
A	6-103	W64	08662-62034	1	DFA Cbl Assy, Rear-panel to A2A4A2

SECTION VIII. SERVICE

Generally throughout the Service Manual, change all references to "A2A4 Frequency Output Assembly" or "A2A4 Frequency Output Board" to "A2A4 Frequency Output/Direct Frequency Access Assembly".

On page 8-201, under Digital Control Unit, change the second sentence to read as follows:

It takes information from the keyboard, HP-IB interface AUX connector, or Direct Frequency Access connector.

On page 8-202, under Instrument Level Troubleshooting, change the first sentence under 3a to read as follows:

Front panel, HP-IB, AUX, and DIRECT FREQUENCY ACCESS malfunctions.

On page 8-203, incorporate the following into Table 8-202:

Connector	Troubleshoot Assembly (Service Sheet)
DIRECT FREQUENCY ACCESS INPUT	A2A4 (12, 13, 13A)

On page 8-205, on Service Sheet A, replace part of Figure 8-201, Overall Block Diagram, with the partial figure on page 11 of this Insert.

On page 8-207/8-208, on Service Sheet B, replace part of Figure 8-202, Digital Control Unit (DCU) Block Diagram, with the partial figure on page 12 of this Insert.

On page 8-325, on Service Sheet 12, replace the top half of Figure 8-335 with the top half of Figure 8-338, P/O A2A4 Frequency Output/Direct Frequency Access Assembly Block Diagram, found on page 13 of this Insert.

Also, on page 8-325, in Figure 8-336: at the upper left corner, replace "P/O A2A4 Frequency Output Board (08662-60167)" with "P/O A2A4A1 Frequency Output Board (08662-62033)"; and in the lower right corner, replace "P/O A2A4 Frequency Output Board Schematic" with "P/O A2A4 Frequency Output/Direct Frequency Access Assembly Schematic."

On page 8-326, under PRINCIPLES OF OPERATION, add the following NOTE at the end of the Monitors section:

NOTE

Due to the Option H25 modifications, when operating the instrument in the DFA mode, certain malfunctions indicated by the front-panel STATUS light may not represent true malfunctions. This occurs because information sent back to the microprocessor when operating in the DFA mode is not the same as that originally sent to the Frequency Output Board by the microprocessor. If the STATUS key is pressed while operating the instrument in the DFA mode, one of the following status errors will be generated: 18, 19, 20 or 22. These errors do not indicate a malfunction during DFA mode; however, if any other status errors are generated then there may be an instrument malfunction. To clear the first errors mentioned above, return the instrument to the normal mode of operation and press the STATUS key. Any STATUS errors generated while operating the unit in the standard mode can be considered an indication of a malfunction and service may be necessary.

On page 8-327, on Service Sheet 13, replace Figure 8-338, P/O A2A4 Frequency Output Board Block Diagrams, with the new Figure 8-338, P/O A2A4 Frequency Output/Direct Frequency Access Assembly Block Diagram, on page 13 of this Insert.

Also on page 8-327, replace part of Figure 8-339, P/O A2A4 Frequency Output Board Schematic, with the new partial Figure 8-339, P/O A2A4 Frequency Output/Direct Frequency Access Assembly Schematic, on page 14 of this Insert.

Add page 8-327a, consisting of Figure 8-339A, A2A4A2 Direct Frequency Access Board Component Locations, found on page 15 of this Insert.

Add page 8-327b, consisting of Service Sheet 13A, containing Figure 8-339B, P/O A2A4A2 Direct Frequency Access Assembly Schematic, found on pages 16 and 17 of this Insert.

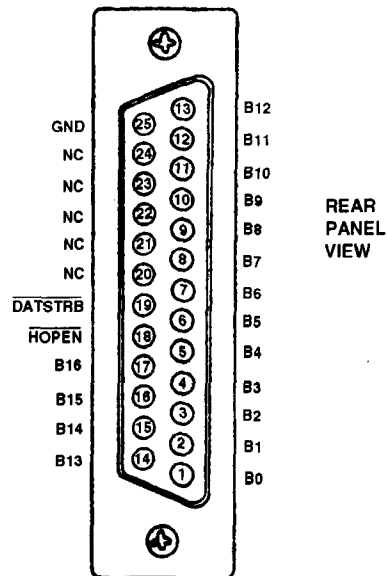

LOGIC LEVELS

Pins 1-15 of the rear-panel Direct Frequency Access (DFA) connector accommodate positive-true (1) 0/5.0V CMOS logic levels. Thus, the true (1) state is +3.5 Vdc to +5.0 Vdc and the false (0) state is 0.0 Vdc to +1.5 Vdc.

Pins 16-18 of the DFA connector accommodate negative-true TTL compatible logic levels. The true (1) state is 0.0 Vdc to +0.4 Vdc and the false (0) state is +2.5 Vdc to +5.0 Vdc.

Pin 19 accommodates positive-true (1) CMOS logic levels (the same levels as pins 1-15 above). The following also applies to pin 19:

Data Setup Time: 150ns (min)
Data Hold Time: 150ns (min)

MATING CONNECTOR

HP 1251-8352; 3M 3634-1000

PROGRAMMING DATA FORMAT

Refer to Section III, Operation.

Figure 2-4. Direct Frequency Access Interface Connection

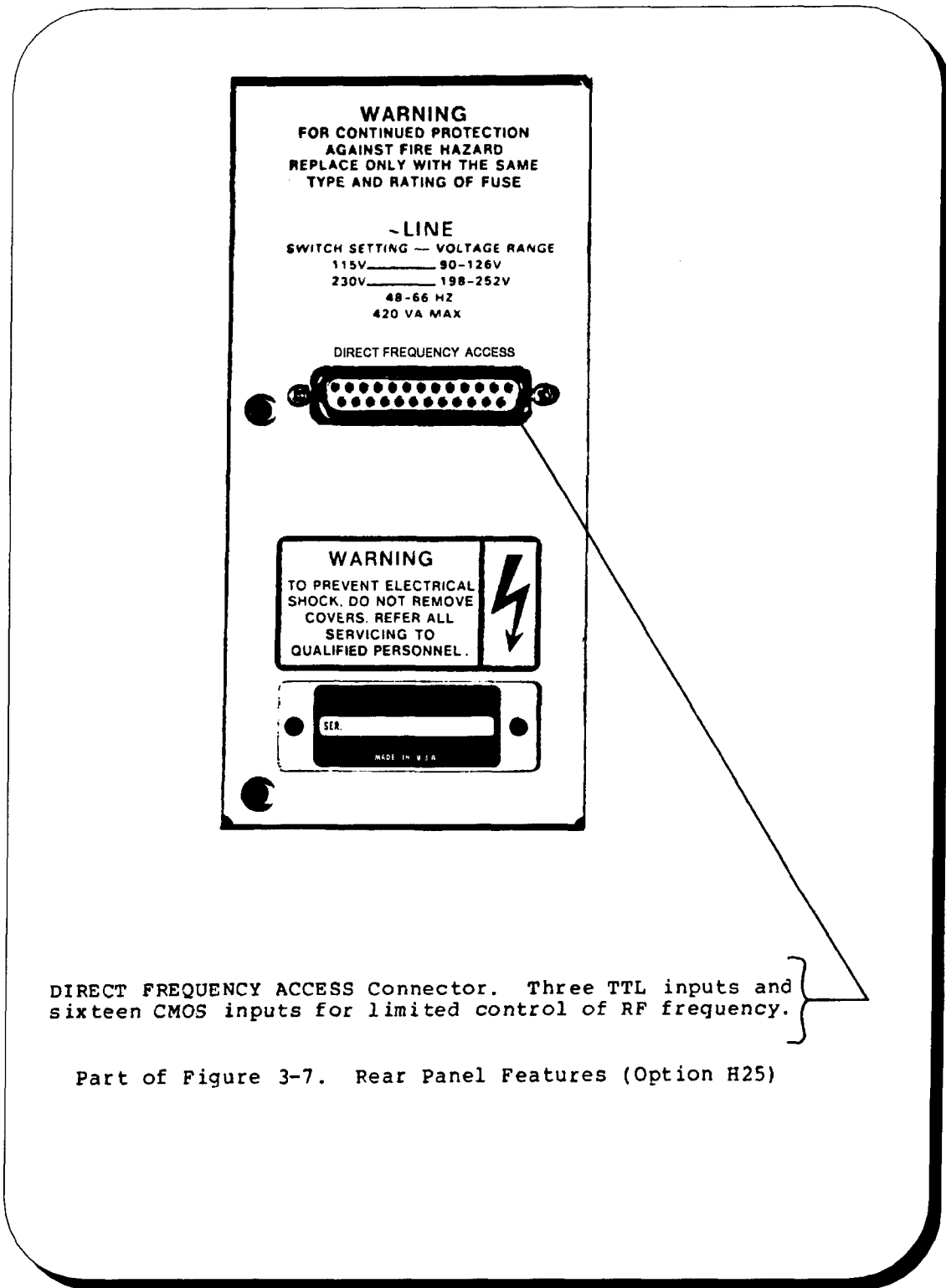

DIRECT FREQUENCY ACCESS Connector. Three TTL inputs and sixteen CMOS inputs for limited control of RF frequency.

Part of Figure 3-7. Rear Panel Features (Option H25)

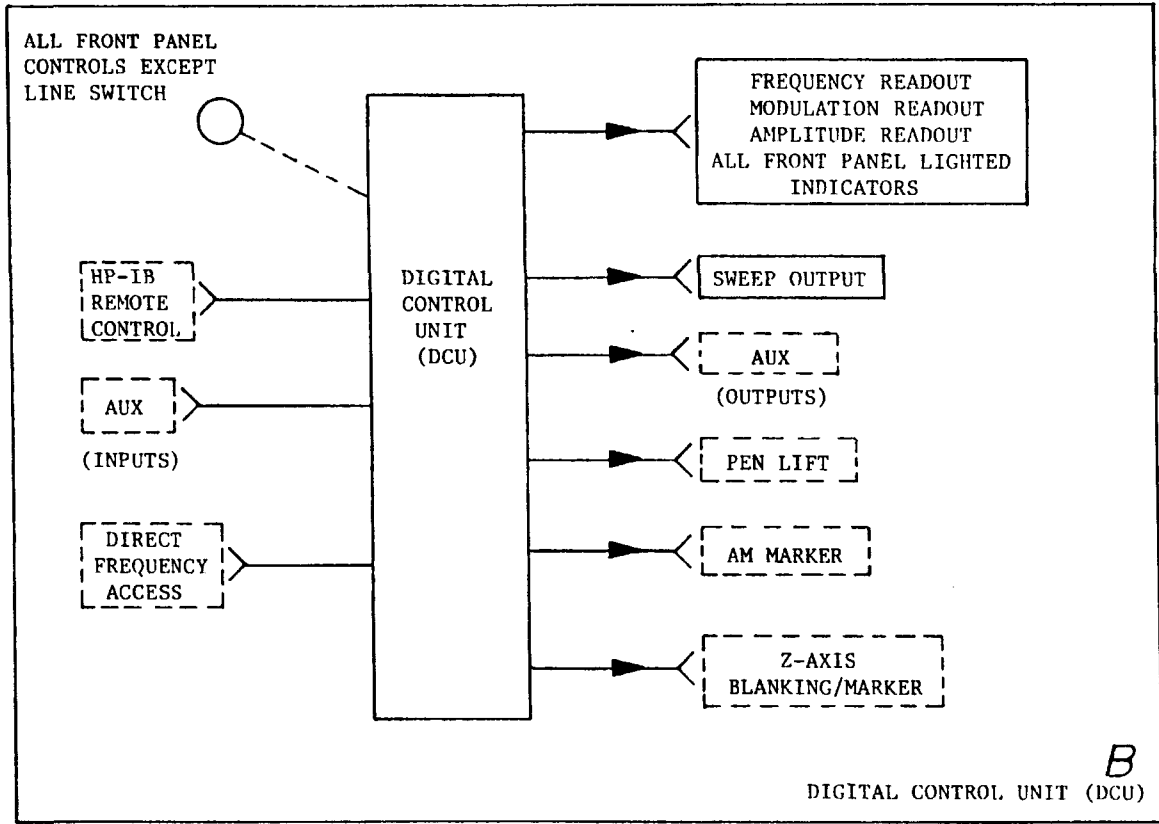

PART OF SERVICE SHEET A.
PART OF FIGURE 8-201.
Overall Block Diagram.

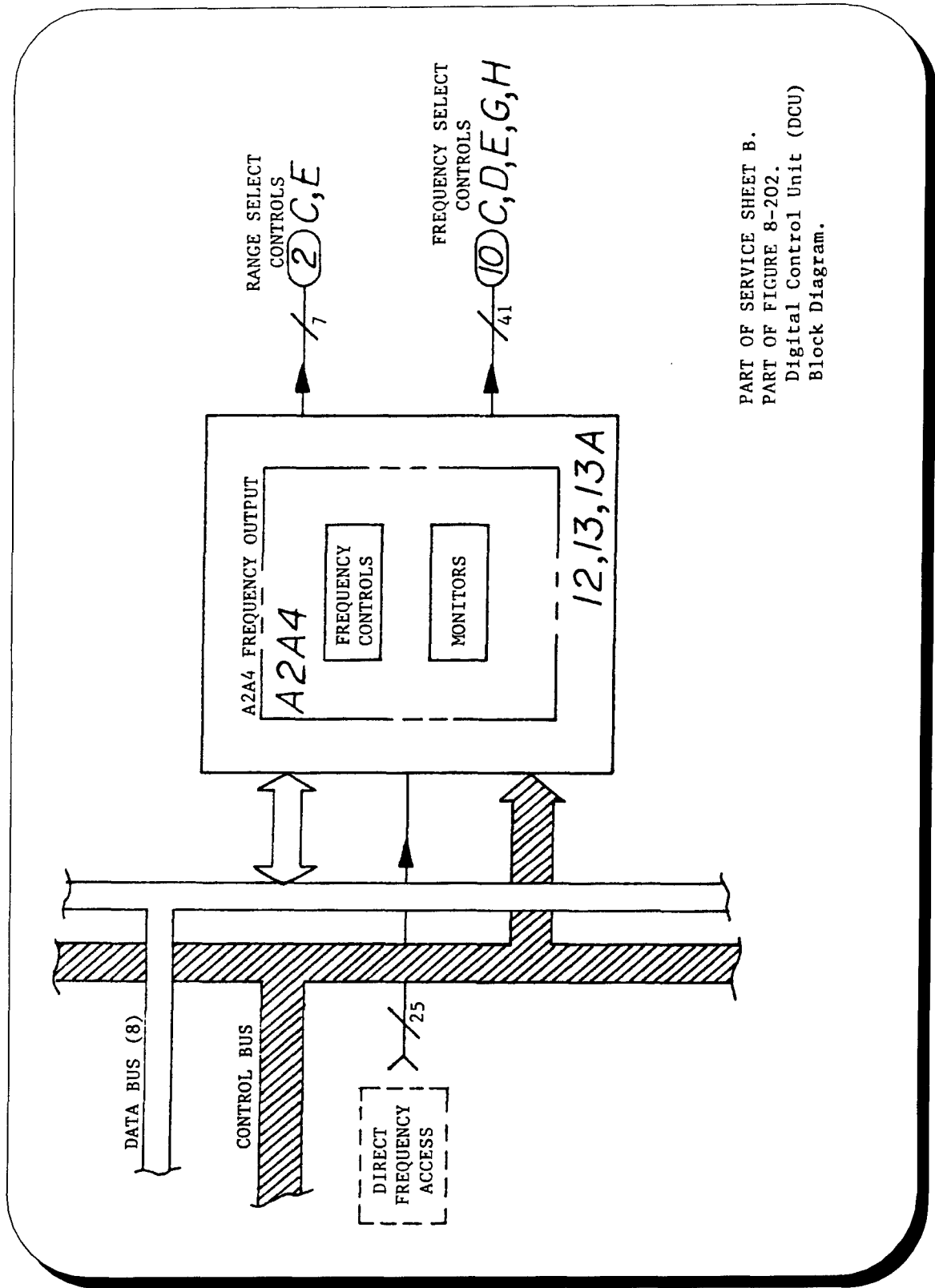

PART OF SERVICE SHEET B.
 PART OF FIGURE 8-202.
 Digital Control Unit (DCU)
 Block Diagram.

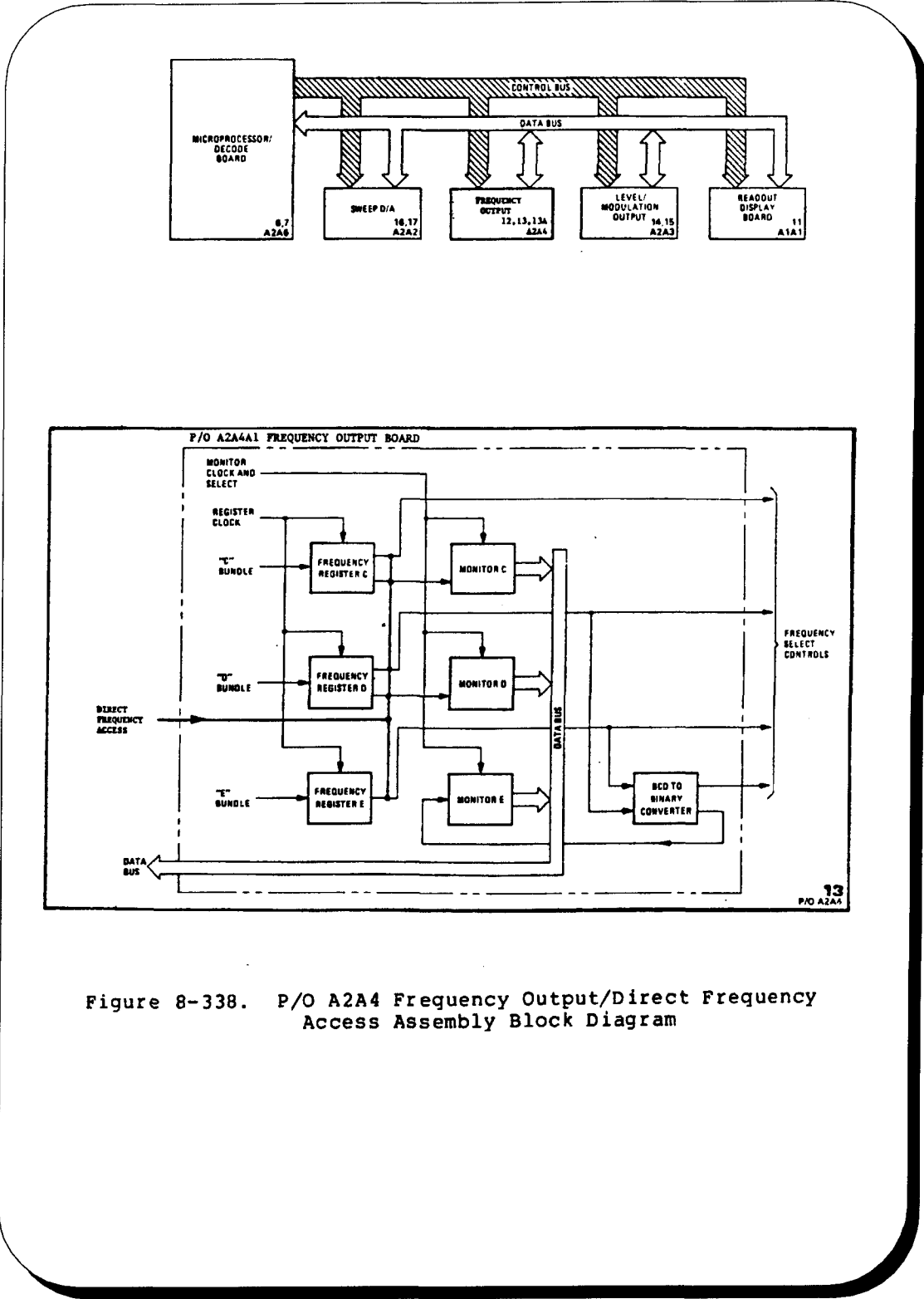
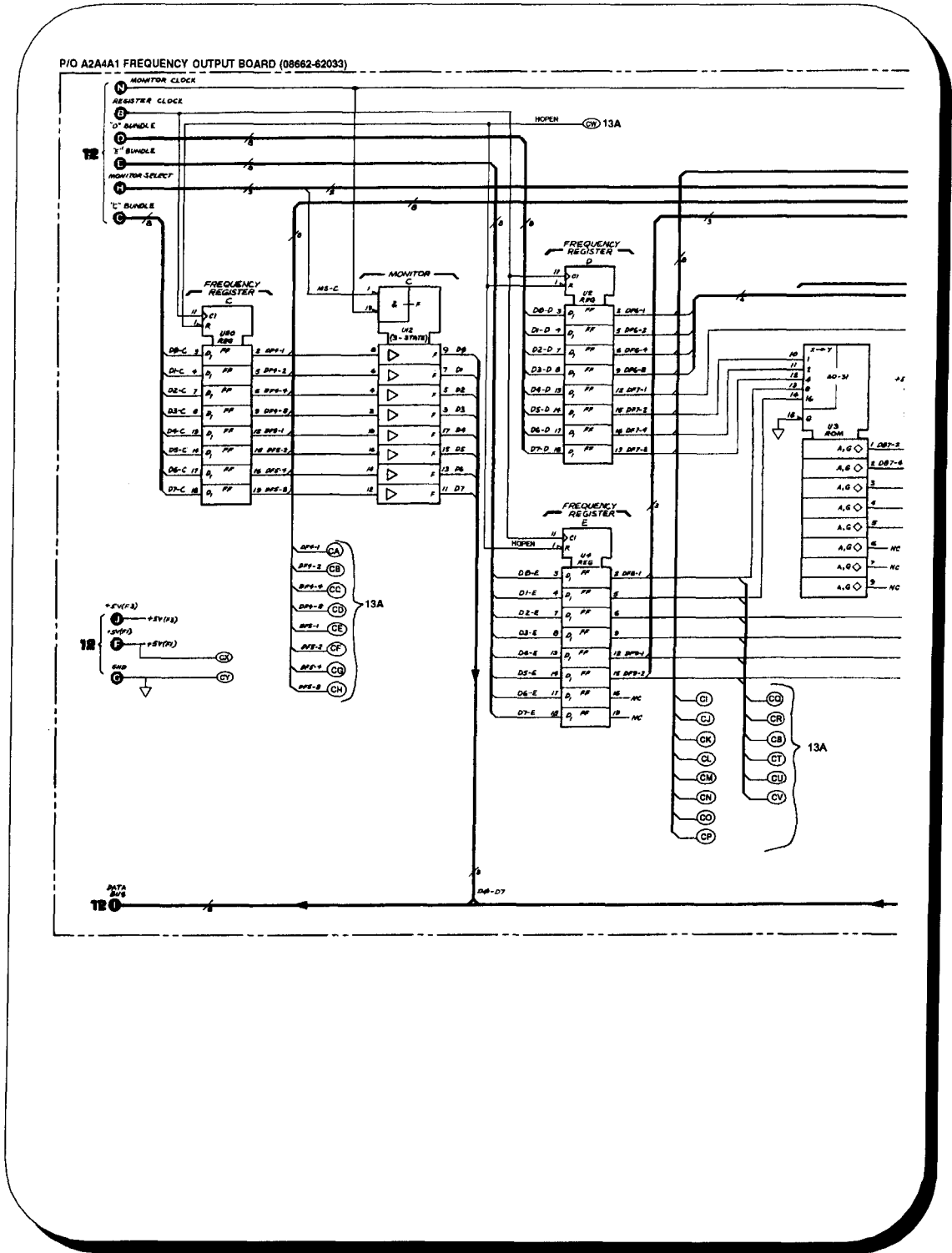

Figure 8-338. P/O A2A4 Frequency Output/Direct Frequency Access Assembly Block Diagram

P/O Figure 8-339. P/O A2A4A1 Frequency Output Board Schematic



P/O Figure 8-339B. P/O A2A4A2 Direct Frequency Access Assembly Schematic

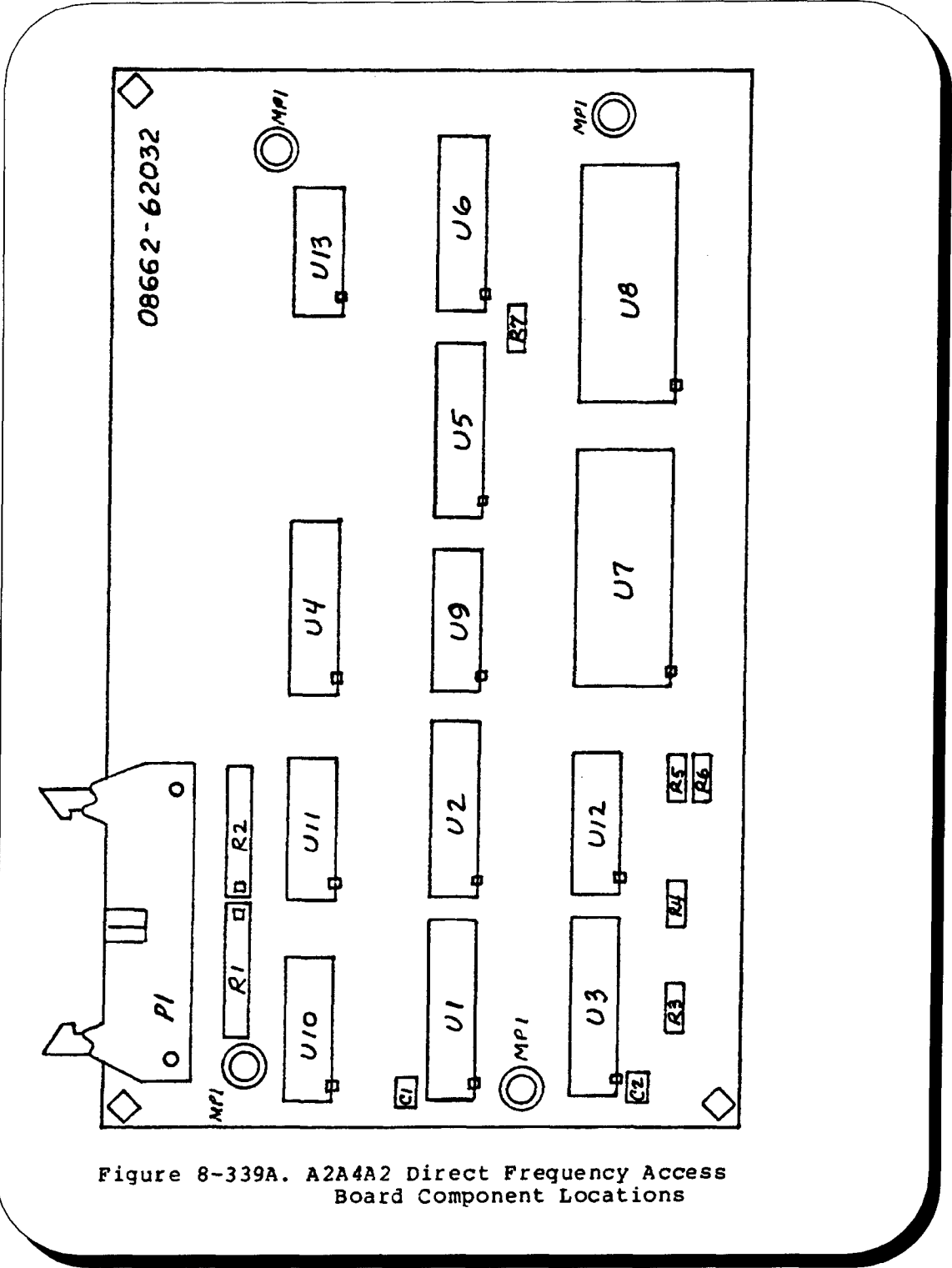
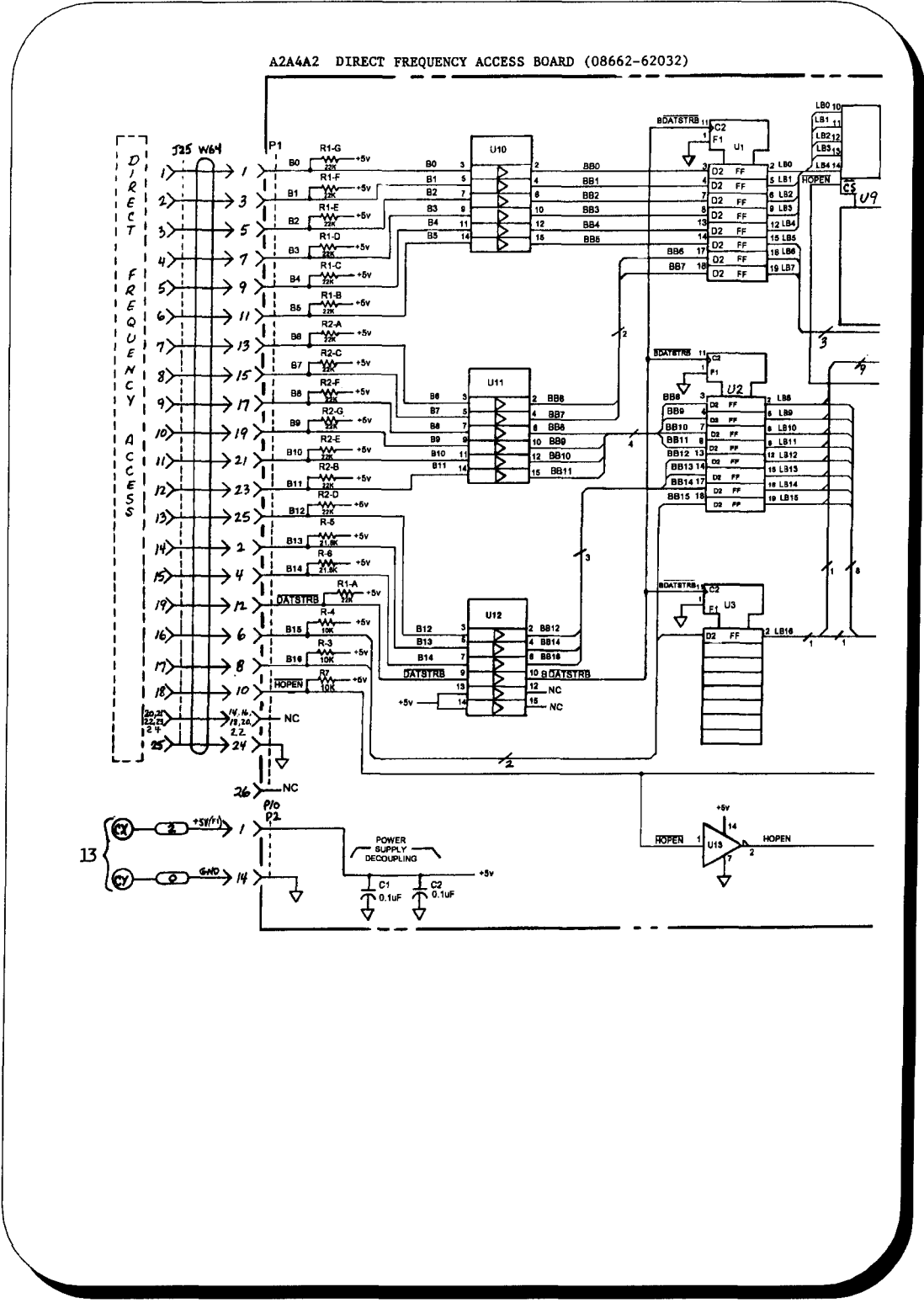

Figure 8-339A. A2A4A2 Direct Frequency Access Board Component Locations

P/O Figure 8-339B. P/O A2A4A2 Direct Frequency Access Assembly Schematic



INTEGRATED CIRCUIT PART NUMBERS
 VOLTAGE AND GROUND CONNECTIONS

REFERENCE DESIGNATION	PART NUMBER	+5V	GND
U1, 2, 3	1820-1907	20	10
U4, 5, 6	1820-2024	20	10
U7	08682-82010	1, 28	14
U8	08682-82011	1, 28	14
U9	08682-82012	16	8
U10, 11, 12	1820-1148	1	8
U13	1820-1199	14	7

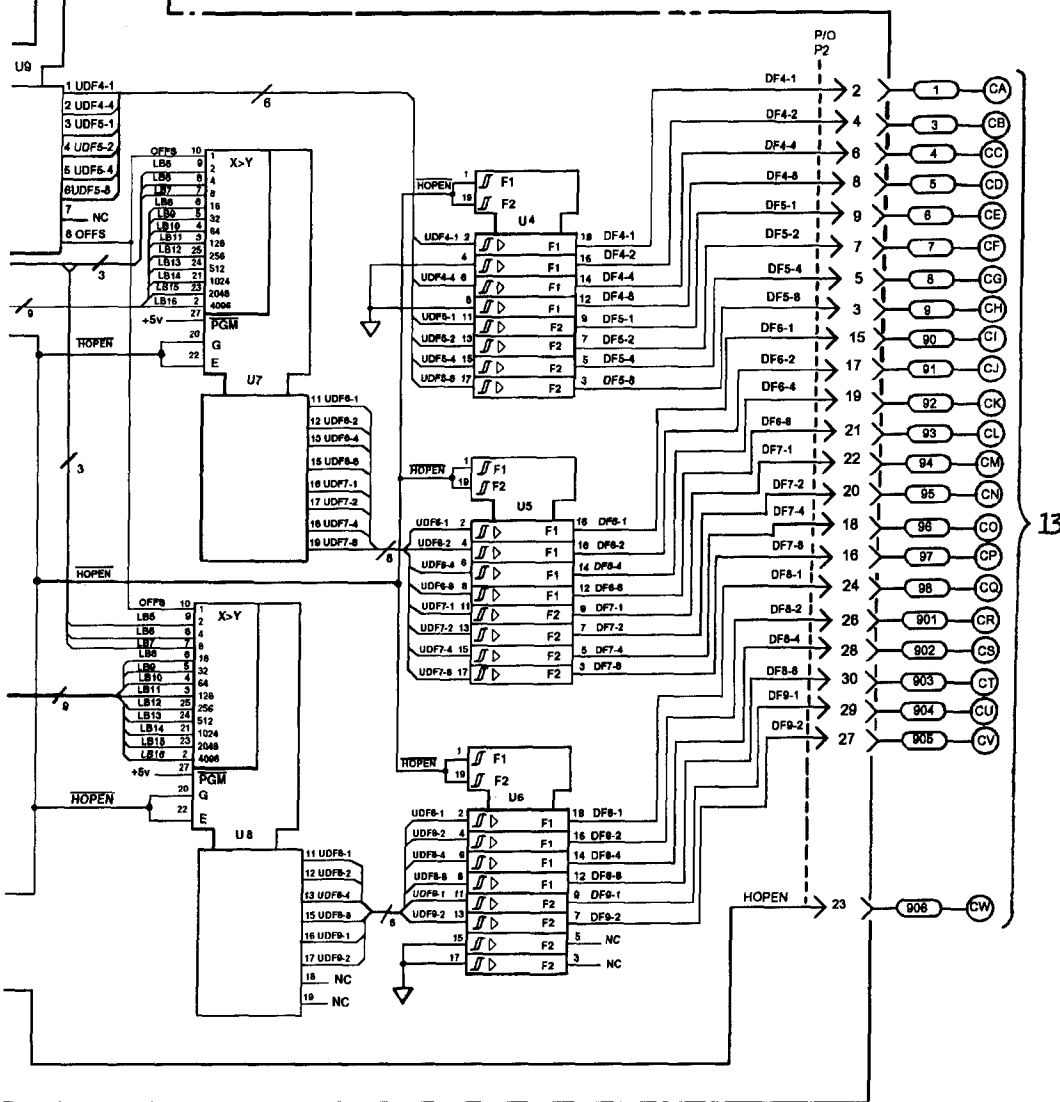

**OPERATING AND SERVICE MANUAL
MODIFICATION**

MODEL 8662A

OPTION H30

SYNTHESIZED SIGNAL GENERATOR

How to Use This Insert

This Manual Modification Insert should be used in conjunction with the Operating and Service Manuals, Volume I (HP Part Number 08662-90061) and Volume II (HP Part Number 08662-90062), both printed February 1982. Make the changes described in this Insert to the indicated Sections of the Operating and Service Manuals.

Applicable Serial Numbers

This Manual Modification Insert applies to instruments with serial number prefixes greater than or equal to 2606A.

Updates to this Manual Insert

Periodically, changes are made to the Manual Insert to correct errors in the original printing and to include Option improvements. Corrections are indicated by a mark at the right-hand edge of the modified text. The mark used is keyed to the date corrections are added (found on this cover below the issue date).

Manual Modification Insert
HP Part Number 08662-92044

Issued March 1986

SECTION I. GENERAL INFORMATION

Option H30 to the HP Model 8662A Synthesized Signal Generator provides an 8662A selected for single-sideband phase noise performance at 10kHz offset from the carrier better than the standard specifications. Option 003 (which specifies the phase noise performance of the rear-panel 640 MHz Output) must be ordered in conjunction with Option H30.

On page 1-4, in Table 1-1, Specifications (1 of 5), under SPECTRAL PURITY, replace the section titled Residual SSB Phase Noise in 1 Hz Bandwidth with the following:

Part of Table 1-1. Specifications

Electronically Characteristics	Performance Limits	Conditions
Residual SSB Phase Noise in 1 Hz Bandwidth on RF Output (Opt 003/H30 only)	-100 dBc -112 dBc -121 dBc -134 dBc -132 dBc -128 dBc	320 to 639.9...MHz; CW or AM mode only 10 Hz offset from carrier 100 Hz offset from carrier 1 kHz offset from carrier 10 kHz offset from carrier 100 kHz offset from carrier 640 to 1279.9...MHz; CW or AM mode only 10 kHz offset from carrier
Absolute SSB Phase Noise in 1 Hz bandwidth on rear-panel 640 MHz Output (Opt 003/H03 only)	-54 dBc -84 dBc -104 dBc -121 dBc -147 dBc -157 dBc -157 dBc	1 Hz offset from carrier 10 Hz offset from carrier 100 Hz offset from carrier 1 kHz offset from carrier 10 kHz offset from carrier 100 kHz offset from carrier 1 MHz offset from carrier
Output Level of rear-panel 640 MHz Output	> +2 dBc	

Since the 8662A Option H30 is factory-selected to meet more stringent specifications, repair, replacement, and/or adjustment of critical parts and assemblies could degrade performance back to standard specifications. Under these conditions, Hewlett-Packard's warranty obligation would be to the standard specifications, not to the Option H30 specifications. For these reasons, Hewlett-Packard recommends that the 8662A Option H30 be returned to the factory for any repairs or adjustments which may affect phase noise performance.

SECTION IV. PERFORMANCE TESTS

On page 4-15 and 4-17, in Sections 4-8 and 4-9, SSB PHASE NOISE TEST and SSB PHASE NOISE TEST (OPTIONAL), replace the sections titled Residual SSB Phase Noise in 1 Hz Bandwidth, with the top portion of Table 1-1 on page 1 of this Insert.

On pages 4-25a through 4-25f (See the yellow Manual Change sheets shipped with the unit), replace all references to "(Option 003 only)" with "(Option 003/H30 only)".

On page 4-25a, in Section 4-12, ABSOLUTE SSB PHASE NOISE ON REAR PANEL 640 MHZ OUTPUT (Option 003/H30 only), replace the SPECIFICATION table with the lower portion of Table 1-1 on page 1 of this Insert.

On page 4-25f, in Section 4-12, in the table under Limit (dBc/Hz), replace "-145" with "-147".

SECTION V. ADJUSTMENTS

Certain adjustments, such as 5-8, the 40 MHz CRYSTAL FILTER ADJUSTMENT, directly affect the phase noise of the 8662A. Other adjustments, such as 5-9, 5-10, and 5-11, can indirectly affect the phase noise of the main RF Output. Therefore, use caution when making any adjustments on Option H30, and verify phase noise performance after making any such adjustments. Refer to the first paragraph at the top of page 2 of this Insert for further information.

SECTION VI. REPLACEABLE PARTS

There are no changes in this section.

SECTION VIII. SERVICE

Before proceeding with repair, replacement, or adjustment of parts or assemblies of Option H30, refer to the first paragraph at the top of page 2 of this Insert.

**OPERATING AND SERVICE MANUAL
MODIFICATION**

MODEL 8662A

OPTION H32

SYNTHESIZED SIGNAL GENERATOR

How to Use This Insert

This Manual Modification Insert should be used in conjunction with the 8662A Operating and Service Manuals, Volumes 1 and 2, HP Part Number 08662-90069 (printed May 1990). Make the changes described in this Insert to the indicated sections of the Operating and Service Manuals.

Applicable Serial Numbers

This Manual Modification Insert applies to the instruments with serial number 2224A01018 only.

Updates to this Manual Insert

Periodically, changes are made to the Manual Insert to correct errors in the original printing and to include Option improvements. Corrections are indicated by a mark at the right-hand edge of the modified text. The mark used is keyed to the date the corrections are added (found on this cover below the issue date).

Manual Modification Insert
HP Part Number 08662-92043

Issued November 1985

SECTION I. GENERAL INFORMATION

Option H32 for the HP Model 8662A Synthesized Signal Generator retrofits a previously shipped 8662A with Options 001, H03, and H12 to a standard instrument with Options H03 and H12.

For warranty information regarding this retrofit refer to the attached "**Warranty Statement of Factory Modification of a Previously Shipped Product**".

**OPERATING AND SERVICE MANUAL
MODIFICATION**

MODEL 8662A

OPTION H40

SYNTHESIZED SIGNAL GENERATOR

How to Use This Insert

This Manual Modification Insert should be used in conjunction with the 8662A Operating and Service Manuals, Volumes 1 and 2, HP Part Number 08662-90069 (printed May 1990). Make the changes described in this Insert to the indicated sections of the Operating and Service Manuals.

Applicable Serial Numbers

This Manual Modification Insert applies to instruments with serial number prefixes greater than or equal to 2614A.

Updates to this Manual Insert

Periodically, changes are made to the Manual Insert to correct errors in the original printing and to include Option improvements. Corrections are indicated by a mark at the right-hand edge of the modified text. The mark used is keyed to the date the corrections are added (found on this cover below the issue date).

Manual Modification Insert
HP Part Number 08662-92045

Issued August 1986

SECTION I. GENERAL INFORMATION

Option H40 to the HP Model 8662A Synthesized Signal Generator provides an 8662A factory-selected for single-sideband (SSB) phase noise from the 640 MHz output better than the specifications of Option 003. Option 003 provides guaranteed SSB phase noise from the 640 MHz low-noise output (Option 003 must be ordered with Option H40.)

All SSB phase noise measurements from the 640 MHz output are defined and guaranteed as measured on an HP 3047A Spectrum Analyzer System with suitable low-noise local oscillators. Because of the nature of these measurements, no allowance has been included in the Option H40 specifications for the uncertainty of the 3047A measurements (typically +/-2dB) or any uncertainty caused by temperature, vibration, or other environmental variations.

On page 1-4, in Table 1-1, Specifications (1 of 5), under SPECTRAL PURITY, add the following after the section titled "Residual SSB Phase Noise in 1 Hz Bandwidth":

Electrical Characteristics	Performance Limits	Conditions
SSB Phase noise in a 1 Hz Bandwidth (640 MHz Output of Option H40) Absolute Noise of the 640 MHz Output (including the noise contribution of the 10811-60209 Reference)	-62dBc -92dBc -112dBc -121dBc -145dBc -157dBc -157dBc	640 MHz; Sweep Mode Disabled 1 Hz Offset from carrier 10 Hz Offset from carrier 100 Hz Offset from carrier 1 kHz Offset from carrier 10 kHz Offset from carrier 100 kHz Offset from carrier 1 MHz Offset from carrier

NOTE

Since the 8662A Option H40 is factory-selected to meet more stringent specifications, any field repair, replacement, and/or adjustment of critical parts and assemblies could upgrade performance back to standard specifications. Under these conditions, Hewlett-Packard's warranty obligation would be to the standard specifications, not to the Option H40 specifications. For these reasons, Hewlett-Packard recommends that the 8662A Option H40 be returned to the factory for any repairs or adjustments which may affect phase noise performance. Factory repair provides Option H40 specifications and is warranted.

On page 1-13, add the following to Table 1-3, Recommended Test Equipment (3 of 3):

Instrument	Critical Specifications	Rec. Model	USE
Spectrum Analyzer System	System Phase Noise: -160 dBc @ 1 kHz -170 dBc @ 10 kHz -170 dBc @ 100 kHz	HP 3047A REQUIRED; NO KNOWN SUBSTITUTES	P

SECTION III. OPERATION

Option H40 is designed to provide an 8662A with very low 640 MHz-output phase noise. To preserve this performance, the user should isolate the 8662A from sources of vibration and acoustic noise as much as possible. These disturbances may cause microphonic spurious responses on the output. One possible way to minimize external vibration coupled to the 8662A is to place the instrument on a foam pad.

Also, note that the 8662A itself produces power-line related spurious signals, as well as fan-generated microphonic spurious signals on its output signal. These spurious signals are not included in Option H40 specifications.

SECTION IV. PERFORMANCE TESTS

On pages 4-25a through 4-25f, replace all references to "(Option 003 only)" with "(Option 003/H40 only)".

On page 4-25a, in 4-12, ABSOLUTE SSB PHASE NOISE ON REAR PANEL 640 MHZ OUTPUT (Option 003/H40 only), replace the table under SPECIFICATION with the table at the top of page 3 of this Insert.

Electrical Specifications	Performance Limit	Conditions
<p style="text-align: center;">SPECTRAL PURITY</p> <p>Absolute SSB Phase Noise on rear panel 640 MHz output</p> <p>Output Level of rear panel 640 MHz output</p>	<p style="text-align: center;">-62 dBc -92 dBc -112 dBc -121 dBc -145 dBc -157 dBc -157 dBc</p> <p style="text-align: center;">> +1 dBm</p>	<p style="text-align: center;">1 Hz measurement Bandwidth</p> <p style="text-align: center;"><u>Offset from carrier</u></p> <p style="text-align: center;">1 Hz 10 Hz 100 Hz 1 kHz 10 kHz 100 kHz 1 Mhz</p>

Also, on page 4-25a, in 4-12, add the following under DESCRIPTION:

The following test procedure may be used as a general performance check of the phase noise of Option H40. However, since Option H40 is defined as being tested on an HP 3047A Spectrum Analyzer System, only this System (and suitable low-noise local oscillators) should be used to verify the performance of Option H40.

On page 4-25f, in 4-12, ABSOLUTE SSB PHASE NOISE ON REAR PANEL 640 MHZ OUTPUT (Option 003/H40 only) (cont'd), replace the table with the table at the top of page 4 of this Insert.

Offset	-----MEASURED NOISE-----			
	Relative to Reference Level (dB/Hz)	Correction	Total (dBc/Hz)	Limit (dBc/Hz)
10 Hz	_____	-59 dB	_____	-92
100 Hz	_____	-59 dB	_____	-112
1 kHz	_____	-59 dB	_____	-121
10 kHz	_____	-59 dB	_____	-145
100 kHz	_____	-59 dB	_____	-157
1 MHz	_____	-59 dB	_____	-157

SECTION V. ADJUSTMENTS

Certain adjustments, such as 5-8, the 40 MHz CRYSTAL FILTER ADJUSTMENT, directly affect the phase noise of the 8662A. Therefore, use caution when making any adjustments on Option H40, and verify phase noise performance after making any such adjustments. Refer to the NOTE at the bottom of page 1 of this Insert for further information.

SECTION VI. REPLACEABLE PARTS

In Table 6-3, Replaceable Parts, add or delete the following parts as noted:

Add or Del	Page No.	Refer. Desig.	HP Part Number	Qty	Description
D	6-90	A8A3	10811-60111	1	10 MHz Reference Oscillator
A	6-90	A8A3	10811-60209	1	10 MHz Reference Oscillator factory-selected for low noise (Option H40)

SECTION VIII. SERVICE

Before proceeding with repair, replacement, or adjustment of parts or assemblies of Option H40, refer to the **NOTE** on page 1 of this Insert.

On page 8-104, under paragraph 8-18, Factory Selected Components (*), incorporate the following:

The 8662A Option H40 includes a factory-selected A8A3 10 MHz Reference Oscillator to insure guaranteed phase noise performance. If it is necessary to replace A8A3, use a factory-tested replacement part (see Table 6-3).

**OPERATING AND SERVICE MANUAL
MODIFICATION**

MODEL 8662A

OPTION H42

SYNTHESIZED SIGNAL GENERATOR

How to Use This Insert

This Manual Modification Insert should be used in conjunction with the 8662A Operating and Service Manuals, Volumes 1 and 2, HP Part Number 08662-90069 (printed May 1990). Make the changes described in this Insert to the indicated sections of the Operating and Service Manuals.

Applicable Serial Numbers

This Manual Modification Insert applies to instruments with serial number prefixes greater than or equal to 2811A.

Updates to this Manual Insert

Periodically, changes are made to the Manual Insert to correct errors in the original printing and to include Option improvements. Corrections are indicated by a mark at the right-hand edge of the modified text. The mark used is keyed to the date the corrections are added (found on this cover below the issue date).

Manual Modification Insert
HP Part Number 08662-92050

Issued June 1988

SECTION I. GENERAL INFORMATION

The HP Model 8662A Synthesized Signal Generator with Option H42 is a standard instrument in every respect. Option H42 provides factory selection of the instrument to obtain the best RF output phase noise performance from a production run of instruments. All specifications for the Option H42 remain the same as the standard instrument and performance is not degraded in any way.

**OPERATING AND SERVICE MANUAL
MODIFICATION**

MODEL 8662A

OPTION H49

SYNTHESIZED SIGNAL GENERATOR

How to Use This Insert

This Manual Modification Insert should be used in conjunction with the 8662A Operating and Service Manuals, Volumes 1 and 2, HP Part Number 08662-90069 (printed May 1990). Make the changes described in this Insert to the indicated sections of the Operating and Service Manuals.

Applicable Serial Numbers

This Manual Modification Insert applies to instruments with serial number prefixes greater than or equal to 3044A.

Updates to this Manual Insert

Periodically, changes are made to the Manual Insert to correct errors in the original printing and to include Option improvements. Corrections are indicated by a mark at the right-hand edge of the modified text. The mark used is keyed to the date the corrections are added (found on this cover below the issue date).

Manual Modification Insert
HP Part Number 08662-92055

Issued May 1991

SECTION I. GENERAL INFORMATION

Option H49 for the HP 8662A Synthesized Signal Generator specifies the residual phase noise of the HP 8662A in the frequency range of 5 to 78 MHz using the HP 3048A Option K38 5 MHz Reference Source as the external reference.

On page 1-4, add the following specifications to Table 1-1, Specifications (1 of 5).

Electrical Characteristics	Performance Limits	Conditions
SPECTRAL PURITY Residual SSB Phase Noise in 1 Hz Bandwidth	-106 dBc -106 dBc -132 dBc	5 to 78 MHz; CW Mode 2 Hz offset from carrier 500 Hz offset from carrier 100 kHz offset from carrier

**OPERATING AND SERVICE MANUAL
MODIFICATION**

MODEL 8662A

OPTION H51

SYNTHESIZED SIGNAL GENERATOR

How to Use This Insert

This Manual Modification Insert should be used in conjunction with the 8662A Operating and Service Manuals, Volumes 1 and 2, HP Part Number 08662-90069 (printed May 1990). Make the changes described in this Insert to the indicated sections of the Operating and Service Manuals.

Applicable Serial Numbers

This Manual Modification Insert applies to instruments with serial number prefixes greater than or equal to 3044A.

Updates to this Manual Insert

Periodically, changes are made to the Manual Insert to correct errors in the original printing and to include Option improvements. Corrections are indicated by a mark at the right-hand edge of the modified text. The mark used is keyed to the date the corrections are added (found on this cover below the issue date).

Manual Modification Insert
HP Part Number 08662-92054

Issued December 1990

SECTION I. GENERAL INFORMATION

Option H51 for the HP 8662A Synthesized Signal Generator provides an instrument that has modified specifications as described in table 1-1 below.

NOTE

Unspecified functions are still present in the instrument. The performance of these functions is not warranted in any way.

On pages 1-4 through 1-10, make the following changes to table 1-1.

Table 1-1. Specifications

Electrical Characteristics	Performance Limits	Conditions
OUTPUT (+15 to +45C): Range	+13 to +5.1 dBm	
Absolute Level Accuracy 4,5	±1.0 dB	+13 to +5.1 dBm
	Not Specified	<+5.1 dBm
Flatness (referenced to 100 MHz, without correction, and down to +5.1 dBm, not specified below +5.1 dBm)	±1.5 dB ±3.5 dB	10 kHz to 640 MHz 10 kHz to 1280 MHz
AMPLITUDE MODULATION	Not Specified	
FREQUENCY MODULATION	Not Specified	
Electrical Characteristics	Features	
DIGITAL SWEEP	Not Specified	
SWEEP MODE	Not Specified	

**OPERATING AND SERVICE MANUAL
MODIFICATION**

MODEL 8662A

OPTION H52

SYNTHESIZED SIGNAL GENERATOR

How to Use This Insert

This Manual Modification Insert should be used in conjunction with the 8662A Operating and Service Manuals, Volumes 1 and 2, HP Part Number 08662-90069 (printed May 1990). Make the changes described in this Insert to the indicated sections of the Operating and Service Manuals.

Applicable Serial Numbers

This Manual Modification Insert applies to instruments with serial number prefixes greater than or equal to 3310A.

Updates to this Manual Insert

Periodically, changes are made to the Manual Insert to correct errors in the original printing and to include Option improvements. Corrections are indicated by a mark at the right-hand edge of the modified text. The mark used is keyed to the date the corrections are added (found on this cover below the issue date).

Manual Modification Insert
HP Part Number 08662-92063

Issued April 1993

SECTION I. GENERAL INFORMATION

Option H52 for the HP 8662A Synthesized Signal Generator specifies power line (60 Hz) related spurious and microphonically generated spurious output performance in the 160 MHz to 320 MHz frequency range to be -90 dBc at offsets 300 Hz.

On page 1-4, add the following specifications to Table 1-1, Specifications (1 of 5).

Electrical Characteristics	Performance Limits	Conditions
<p>SPECTRAL PURITY Spurious Output Signals [Power line (60 Hz) related or microphonically generated (within 300 Hz from the carrier)]</p> <p>Note: At 50 Hz line frequency power line or microphonically related spurious may be up to 3 dB higher and appear at offsets as high as 1 kHz from carrier.</p>	<p>-90 dBc -85 dBc -90 dBc -75 dBc -70 dBc</p>	<p>0.01 to 120 MHz 120 to 160 MHz 160 to 320 MHz 320 to 640 MHz 640 to 1280 MHz</p>

SECTION IV. PERFORMANCE TESTS

On page 4-20, add the following specifications to the table for 4-10. **HARMONICS AND SPURIOUS TEST.**

Electrical Characteristics	Performance Limits	Conditions
<p>Spurious Output Signals [Power line (60 Hz) related or microphonically generated (within 300 Hz from the carrier)]⁴</p>	<p>-90 dBc -85 dBc -90 dBc -75 dBc -70 dBc</p>	<p>0.01 to 120 MHz 120 to 160 MHz 160 to 320 MHz 320 to 640 MHz 640 to 1280 MHz</p>

**OPERATING AND SERVICE MANUAL
MODIFICATION**

MODEL 8662A

OPTION H55

SYNTHESIZED SIGNAL GENERATOR

How to Use This Insert

This Manual Modification Insert should be used in conjunction with the 8662A Operating and Service Manuals, Volumes 1 and 2, HP Part Number 08662-90069 (printed May 1990). Make the changes described in this Insert to the indicated sections of the Operating and Service Manuals.

Applicable Serial Numbers

This Manual Modification Insert applies to instruments with serial number prefixes greater than or equal to 3423A.

Updates to this Manual Insert

Periodically, changes are made to the Manual Insert to correct errors in the original printing and to include Option improvements. Corrections are indicated by a mark at the right-hand edge of the modified text. The mark used is keyed to the date the corrections are added (found on this cover below the issue date).

Manual Modification Insert
HP Part Number 08662-92065

Issued September 1994

SECTION I. GENERAL INFORMATION

Copyright 1994 -- HEWLETT-PACKARD COMPANY -- Spokane Division
24001 E. Mission Ave, Liberty Lake, WA 99019-9599 U.S.A.

Option H55 to the HP Model 8662A Synthesized Signal Generator provides the phase noise plots of system performance at 60 MHz and 80 MHz as provided on page 2 and 3 of this insert. This data applies only to Serial Number 3423A04392. This plot indicates measured performance of this specific 8662A before it left the factory. However, this 8662A is not guaranteed to have these same characteristics upon customer receipt. Guaranteed specifications for the instrument are listed in Table 1-1 on page 1-4.

SECTION III. OPERATION

Standard operation of the 8662A is unaffected by Option H55.

SECTION V. ADJUSTMENTS

Certain adjustments, such as 5-8, the 40 MHz CRYSTAL FILTER ADJUSTMENT, directly affect the phase noise of the 8662A. Therefore, use caution when making any adjustments on Option H55 instruments, and verify phase noise performance after making any such adjustments.

3048 SYSTEM TEST 8662A H55 SN 3423A04392

[hp] 3048A Carrier: 60.E+6 Hz 13 Sep 1994 14:59:41 - 15:13:51

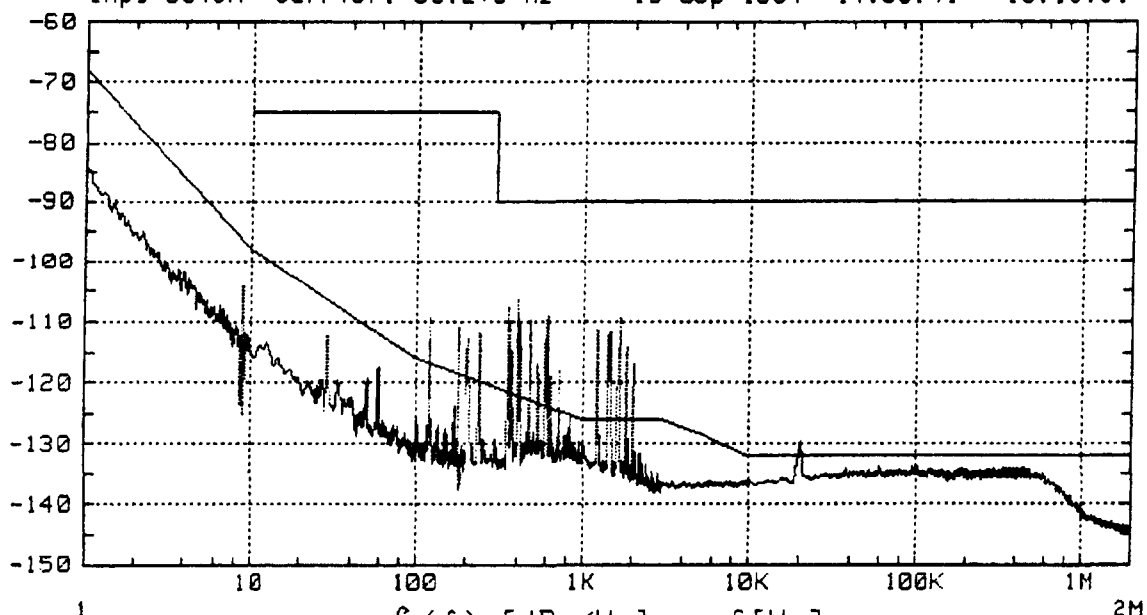

1 $L(f)$ [dBc/Hz] vs f [Hz] 2M

Meas. Type: PHASE LOCKED	K_VCO Method: MEASURED
Start Freq: 1 Hz	K_vco : 836.E-3 Hz/Volt
Stop Freq: 2.E+6 Hz	
Min. Aves: 20	Loop Suppr. : VERIFIED
	Clsd P11 Bw.: 6.222 Hz
Carrier Freq: 80.E+6 Hz	Peak Tun Rng: 7.33 Hz
Det. In Freq: 80.E+6 Hz	Assumed Pole: 3.E+3 Hz
Entered Kvco: 800.E-3 Hz/Volt	D.U.T. : USER'S SRCE, MAN
Center Voltg: -400.E-3 Volts	Ref. Source : USER'S SRCE, MAN, VCO
Tune Rnge: +/- 10 Volts	Ext. Tmbase : NOT IN USE
Ph. Detector: 5 TO 1600 MHz	On Converter: NOT IN USE
K_phi Method: MEASURED	HP11848A LNA: IN
K_phi : 585.6E-3 V/Rad	

3048 SYSTEM TEST 8662A H55 SN 3423A04392

[hp] 3048A Carrier: 80.E+6 Hz 13 Sep 1994 15:27:39 - 15:41:51

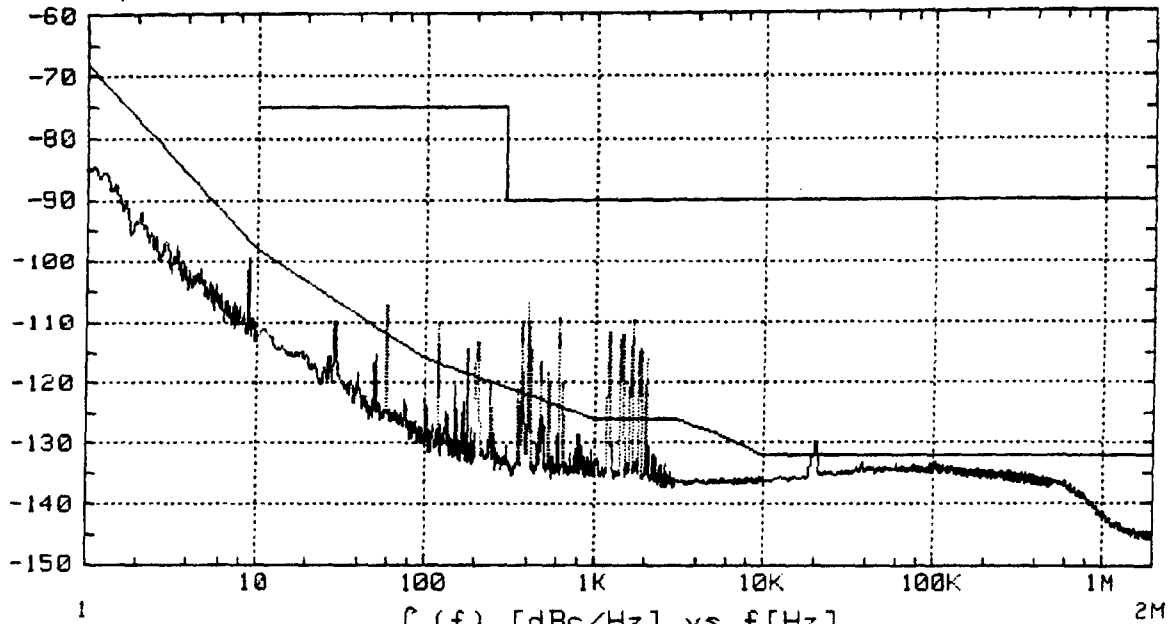

Meas. Type: PHASE LOCKED	K_VCO Method: MEASURED
Start Freq: 1 Hz	K_vco : 836.E-3 Hz/Volt
Stop Freq: 2.E+6 Hz	
Min. Aves: 20	Loop Suppr. : VERIFIED
	Clsd P11 Bw.: 6.222 Hz
Carrier Freq: 80.E+6 Hz	Peak Tun Rng: 7.33 Hz
Det. In Freq: 80.E+6 Hz	Assumed Pole: 3.E+3 Hz
Entered Kvco: 800.E-3 Hz/Volt	D.U.T. : USER'S SRCE, MAN
Center Voltg: -400.E-3 Volts	Ref. Source : USER'S SRCE, MAN, VCO
Tune Rnge: +/- 10 Volts	Ext. Tmbase : NOT IN USE
Ph. Detector: 5 TO 1600 MHz	Dn Converter: NOT IN USE
K_phi Method: MEASURED	HP11848A LNA: IN
K_phi : 585.6E-3 V/Rad	

**OPERATING AND SERVICE MANUAL
MODIFICATION**

MODEL 8662A

OPTION H60

SYNTHESIZED SIGNAL GENERATOR

How to Use This Insert

This Manual Modification Insert should be used in conjunction with the 8662A Operating and Service Manuals, Volumes 1 and 2, HP Part Number 08662-90069 (printed May 1990). Make the changes described in this Insert to the indicated sections of the Operating and Service Manuals.

Applicable Serial Numbers

This Manual Modification Insert applies to instruments with serial number prefixes greater than or equal to 2650A.

Updates to this Manual Insert

Periodically, changes are made to the Manual Insert to correct errors in the original printing and to include Option improvements. Corrections are indicated by a mark at the right-hand edge of the modified text. The mark used is keyed to the date the corrections are added (found on this cover below the issue date).

Manual Modification Insert
HP Part Number 08662-92047

Issued January 1987

SECTION I. GENERAL INFORMATION

Option H60 to the HP Model 8662A Synthesized Signal Generator provides an 8662A selected for guaranteed single-sideband (SSB) phase noise performance from the RF Output at a carrier frequency of 72.27 MHz. Option 003 must be ordered in conjunction with Option H60.

A plot of the phase noise performance at 72.27 MHz is provided on page 3 of this insert. This data applies only to Serial Number _____. This plot indicates measured performance of this specific 8662A before it left the factory. However, this 8662A is not guaranteed to have these same characteristics upon customer receipt. Guaranteed specifications for the instrument are listed in Table 1-1 on page 1-4.

On page 1-4, in Table 1-1, Specifications (1 of 5), under SPECTRAL PURITY, add the following after the section titled "Residual SSB Phase Noise in 1 Hz Bandwidth":

Electrical Characteristics	Performance Limits	Conditions
Absolute SSB Phase Noise in a 1 Hz Bandwidth		72.27 MHz Only
Absolute Noise (including the noise contribution of the 10811-60111 Reference Oscillator)	-68dBc -98dBc -116dBc -126dBc -132dBc -133dBc	1 Hz Offset from carrier 10 Hz Offset from carrier 100 Hz Offset from carrier 1 kHz Offset from carrier 10 kHz Offset from carrier 100 kHz Offset from carrier

SECTION III. OPERATION

Standard operation of the 8662A is unaffected by Option H60.

SECTION V. ADJUSTMENTS

Certain adjustments, such as 5-8, the 40 MHz CRYSTAL FILTER ADJUSTMENT, directly affect the phase noise of the 8662A. Therefore, use caution when making any adjustments on Option H60 instruments, and verify phase noise performance after making any such adjustments.

