

Keysight 87204/87206A, B, C Multiport Coaxial Switches

dc to 4 GHz, dc to 20 GHz, dc to 26.5 GHz

Technical Overview

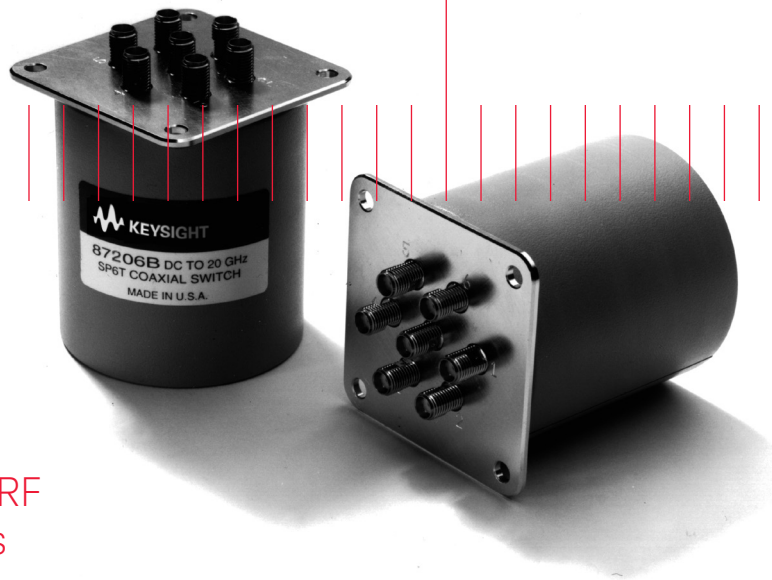

High performance multiport
switches for microwave and RF
instrumentation and systems

- SP4T and SP6T configuration
- Exceptional repeatability for more than 5 million cycles
- Excellent isolation, typically >90 dB at 26.5 GHz
- Magnetic latching
- Terminated ports
- Self-interrupting drive circuit
- Fully compatible with Keysight 87130A/70611A switch drivers

Modern automated test systems demand higher accuracy and performance than ever before. The Keysight Technologies Inc. 87204A/B/C and 87206A/B/C multiport switches offer excellent insertion loss repeatability and high isolation necessary to achieve superior test system performance. Long life, repeatability, and reliability reduce the cost of ownership by reducing calibration cycles and increasing test system uptime. These features are vital to ATS measurement system integrity over time.

Description

The 87204A/B/C SP4T and 87206A/B/C SP6T terminated multiport switches provide the life and reliability required for automated test and measurement, signal monitoring, and routing applications. Innovative design and careful process control create switches which meet the requirements for highly repeatable switching elements in test instruments and switching interfaces. The switches are designed to operate for more than 10 million cycles. The exceptional 0.03 dB insertion loss repeatability is warranted for 5 million cycles at 25 °C. This reduces sources of random errors in the measurement path and improves measurement uncertainty. Switch life is a critical consideration in production test systems, satellite and antenna monitoring systems, and test instrumentation. The longevity of these switches increases system uptime, and lowers the cost of ownership by reducing calibration cycles and switch maintenance.

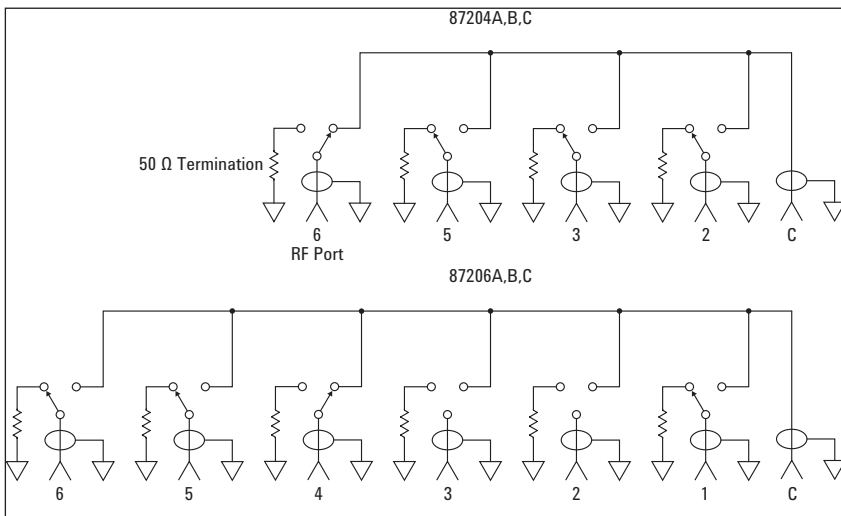

Figure 1. Keysight 87204A/B/C and 87206A/B/C simplified schematics

Operating to 4 GHz (A models), 20 GHz (B models), and 26.5 GHz (C models), these switches exhibit exceptional isolation performance required to maintain measurement integrity. Isolation between ports is typically >100 dB to 12 GHz and >90 dB to 26.5 GHz. This reduces the influence of signals from other channels, sustains the integrity of the measured signal, and reduces system measurement uncertainties. These switches also minimize measurement uncertainty with low insertion loss and reflection, which makes them ideal elements in large, multi-tiered switching systems.

Both the 87204A/B/C and 87206A/B/C are designed to fall within most popular industry footprints. The 2¼ inch square flange provides mounting holes, while the rest of the 2½ inch long by 2¼ inch diameter body will easily fit into most systems. Ribbon cable or optional solder terminal connections accommodate the need for secure and efficient control cable attachment.

Option 100 provides solder terminal connections in place of the 16-pin ribbon drive cable. Option 100 does not incorporate the “open all paths” feature.

Each port is individually controlled by its corresponding “close” and “open” control lines. All open paths are terminated with 50-ohm loads. A port is closed or open when its corresponding “close” or “open” pin is connected to ground. At this point, the current to the solenoids is shut off by the optoelectronic interrupts. This improves reliability and extends the life of the switch by eliminating dc circuit contact failures characteristic of conventional electromechanical switches. This configuration allows compatibility with the Keysight 87130A and Keysight 70611A switch drivers’ position monitoring and reporting feature.

Applications

Multiport switches find use in a large number of applications, increasing system flexibility and simplifying system design.

Simple signal routing

The simplest signal routing scheme takes the form of single input to multiple outputs. These matrixes are often used at the input of an analyzer to test several two-port devices sequentially or to test multiport devices. In surveillance applications, a multiport switch can be used to select the optimum antenna for intercepting a signal.

Two methods can be used to accomplish the single input to multiple output arrangement. Traditionally, where isolation greater than 60 dB was required, a tree matrix composed of SPDT switches was used. While this provided high isolation, it was at the cost of more switches (Figure 2). The 87204 and 87206 switches have port-to-port isolations typically greater than 90 dB at 26.5 GHz, eliminating the need for a tree matrix to achieve high isolation (Figure 3). In addition to the reduced part count, the path lengths are shorter, so insertion loss is less. Also, paths are of equal length, so phase shift is constant.

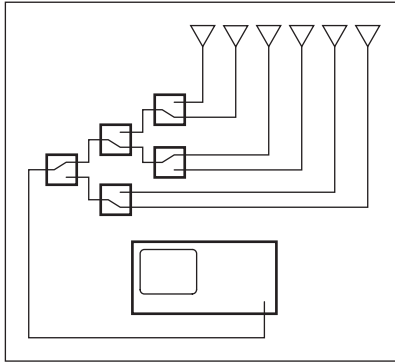

Figure 2. Tree matrix

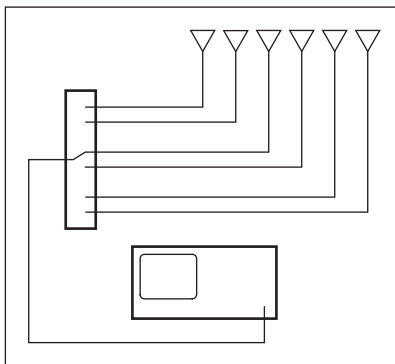

Figure 3. Multiport matrix

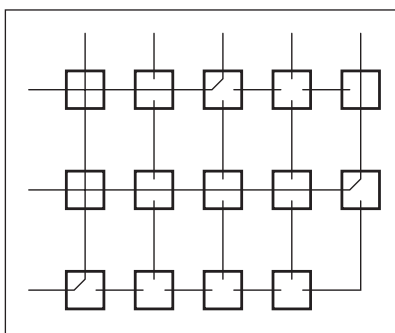

Figure 4. Cross-point matrix

Full access switching

Full access switching systems have the flexibility to route multiple input signals to multiple outputs simultaneously. Full access switching matrixes are used in test systems to provide flexible routing of signals between different devices under test and stimulus and analysis instrumentation. Cross-point matrixes, using single-pole double-throw and cross-point switches, have traditionally been used to maintain high channel-to-channel isolation (Figure 4). As with the tree matrixes, this is at the cost of hardware and performance. Full access switching can also be achieved using multiport switches (Figure 5).

The advantage of the multiport matrix over the cross-point matrix is lower insertion loss and improved SWR performance due to consistent path length and fewer switches and connecting cables.

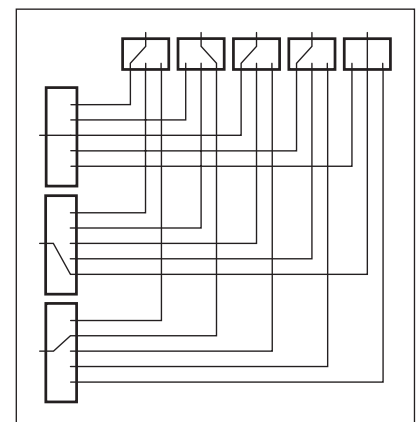

Figure 5. Full access matrix

Dedicated switching

There are a number of applications where switching will be used, not for flexibility, but to accomplish a particular function within an instrument. For example, switched filter banks for reducing harmonics in the output of sources or at the input of analyzers can use multiport switches in series to select the right filter for the band of interest.

Driving the switch

Each RF path is controlled independently. An “open” or “closed” signal must be sent to achieve the desired state for each section of the switch (see Figure 8 on page 9 for drive connection diagrams).

- Connect pin 1 to supply (+20 Vdc to +32 Vdc).
- Connect pin 15 to ground (see Note 1).
- “Open” desired RF path by applying ground to the corresponding “open” pin; for example, ground pin 4 to open RF path 1 (see Notes 2, 3).
- Close desired RF path by applying ground to the corresponding RF path “close” pin; for example, ground pin 3 to close RF path 1 (see Notes 2, 3).
- To open all RF paths, ensure that RF path “close” pins are disconnected from ground. Then, connect pin 16 to ground. Note: This feature is not available with Option 100.

For larger switching systems, where many switches will be used to provide complex signal routing, a switch driver such as the Keysight 87130A or 70611A is recommended. The 87130A rack-and-stack switch driver and the MMS-based 70611A are convenient, flexible GPIB or MSIB switch controllers, providing driver circuitry, position monitoring, and reporting, and firmware that makes it easy to integrate switch components into a switching system.

The 87130A must be controlled by either a PC or workstation-based GPIB controller and appropriate software (for example, Keysight ITG or VEE).¹

The 70611A gives manual control via the MMS user interface or can also be controlled via a GPIB-equipped PC or workstation.

Accessory cables and adapters make it easy to connect an 87204/87206 to the 87130A (see Ordering Information). In addition, the built-in firmware makes it possible to define frequently used switch paths. With the path command, macros can be designed which open and close the right solenoids to select the desired switch port; this path may then be named.

A programmable wake-up condition makes it possible to ensure that the matrix or switching system starts up in a predetermined state.

For smaller switching needs, the Keysight 11713B 10-channel attenuator/switch controller provides simple GPIB control for one 87206 and one 87204 or two 87204 switches with Option 100. Connecting cables can be ordered that make it easy to connect the switches to the 11713B (see Ordering Information).

Notes:

1. Pin 15 must always be connected to ground to enable the electronic position-indicating circuitry and drive logic circuitry.
CAUTION: IF PIN 15 IS NOT CONNECTED TO POWER SUPPLY GROUND, CATASTROPHIC FAILURE WILL OCCUR.
2. After the RF path is switched and latched, the drive current is automatically interrupted by the electronic position-sensing circuitry. Pulsed control is not necessary, but if implemented, the pulse width must be 15 ms minimum to ensure that the switch is fully latched.
3. Make-before-break switching can be accomplished by closing the new RF path before opening the old RF path. This will simultaneously engage the old RF path and the new RF path. Once the new RF path is engaged (15 ms), open the closed path by grounding the RF path open select pin. Break-before-make is accomplished by opening the old RF path before closing the new RF path.

1. ITG: Instrument Test Generator, VEE: Visual Engineering Environment

Specifications

Specifications describe the instrument's warranted performance. **Supplemental** and **typical characteristics** are intended to provide information useful in applying the instrument by giving typical, but not warranted performance parameters.

Maximum power rating	
Into internal termination	1 W CW, 50 W pk, 10 us max pulse duration, not to exceed 1 W average
Into thru path Hot switching	2 W CW, 100 W pk, 10 us max pulse duration, not to exceed 2 W average
Cold switching	150 W CW at 3 GHz, 25 °C 120 W CW at 4.2 GHz, 25 °C
Life	5,000,000 cycles minimum
Switching speed	15 ms maximum

Environmental specifications

Operating temperature	-25 to 75 °C
Storage temperature	-55 to 85 °C
Temperature cycling	-55 to 85 °C, 10 cycles per MIL-STD-202F, Method 107D, Condition A (modified)
Vibration	
Operating	7 g: 5 to 2000 Hz at 0.25 in p-p
Survival	20 g: 20 to 2000 Hz at 0.06 in p-p, 4 min/cycle, 4 cycles/axis
Random	2.41 g (rms) 10 min/axis
Shock	
Half-sine	500 g at 0.5 ms, 3 drops/direction, 18 total
Operating	50 g at 6 ms, 6 directions
Moisture resistance	65 °C, 95% RH, 10 days per MIL-STD-202F, Method 106E
Altitude storage	50,000 feet (15,240 meters per MIL-STD-202F, Method 105C, Condition B)
RFI	Per MIL-STD-461C, RE02, Part 4
Magnetic field	<5 gauss ¼ inch from surface

Physical specifications

Dimensions	Per Figure 9 on page 10
Weight	229 gm (0.50 lb)

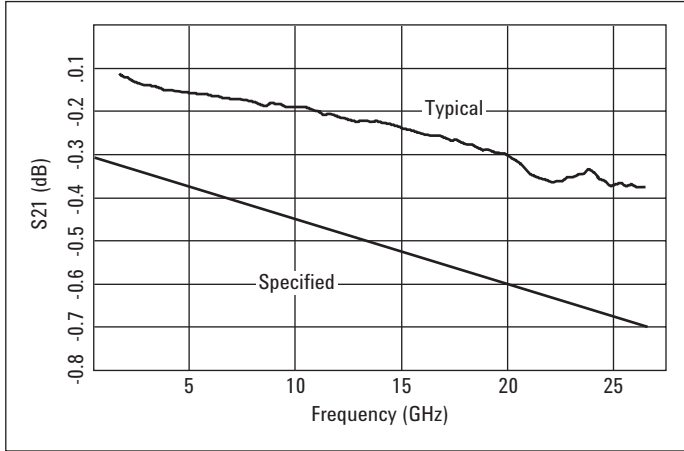

Figure 6. Insertion loss

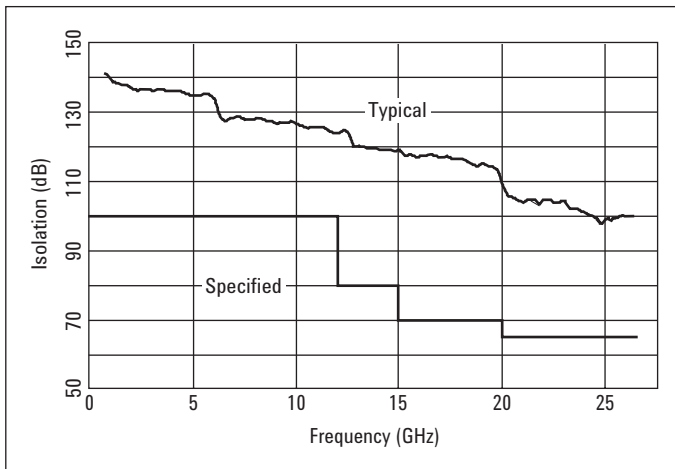

Figure 7. Isolation

Switch drive specifications

Parameter	Conditions	Min	Nom	Max	Units
Supply Voltage, Vcc		20	24	32	V
Supply Current, Icc	Switching: Pulse width \geq 15 ms Vcc = 24 Vdc		2001		
Supply Current, Icc (quiescent)		25		50	mA

1. Closing one RF path requires 200 mA. Add 200 mA for each additional RF path closed or opened.

	87204A 87206A	87204B 87206B	87204C 87206C
Frequency range	dc to 4 GHz	dc to 20 GHz	dc to 26.5 GHz
Insertion loss (see Figure 6)	0.3 dB + 0.015 x frequency (GHz)	0.3 dB + 0.015 x frequency (GHz)	0.3 dB + 0.015 x frequency (GHz)
Isolation (see Figure 7)	100 dB minimum	100 dB minimum to 12 GHz 80 dB minimum to 12 to 15 GHz 70 dB minimum to 15 to 20 GHz	100 dB minimum to 12 GHz 80 dB minimum to 12 to 15 GHz 70 dB minimum to 15 to 20 GHz 65 dB minimum to 20 to 26.5 GHz
SWR	1.2:1 maximum	1.2 maximum dc to 4 GHz 1.35 maximum 4 to 12.4 GHz 1.45 maximum 12.4 to 18 GHz 1.7 maximum 18 to 20 GHz	1.2 maximum dc to 4 GHz 1.35 maximum 4 to 12.4 GHz 1.45 maximum 12.4 to 18 GHz 1.7 maximum 18 to 26.5 GHz
Repeatability (Up to 5 million cycles measured at 25 °C)	0.03 dB maximum	0.03 dB maximum	0.03 dB maximum
Connectors	SMA (f)	SMA (f)	SMA (f)

Supplemental characteristic

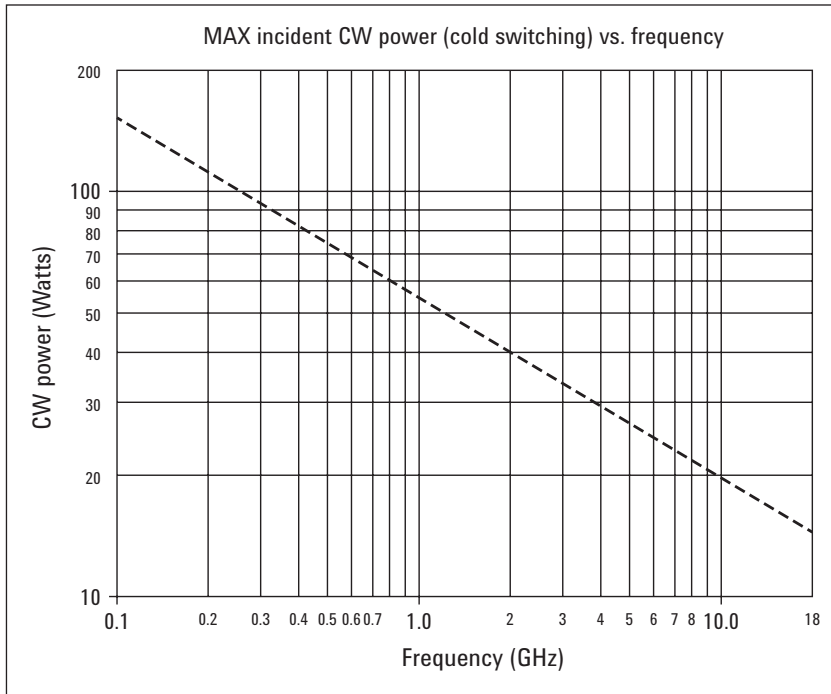

Reference conditions:

- Cold switching only (NO Hot switching)
- Ambient temperature of 75 °C or less
- Sea level (0.88 derating @ 15,000 ft.)
- Load VSWR < 1.2 (see graph for derating above 1.2 VSWR)

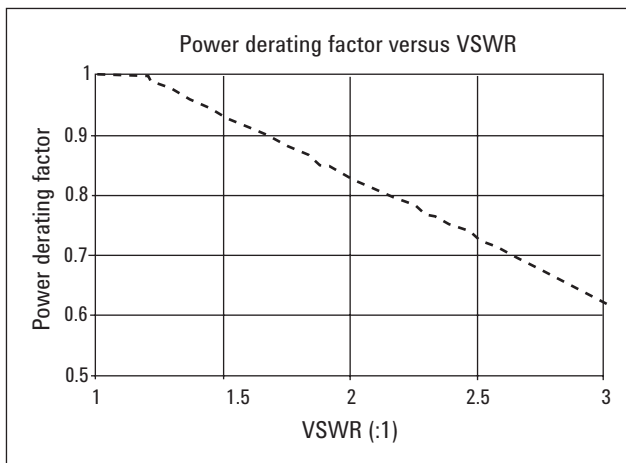

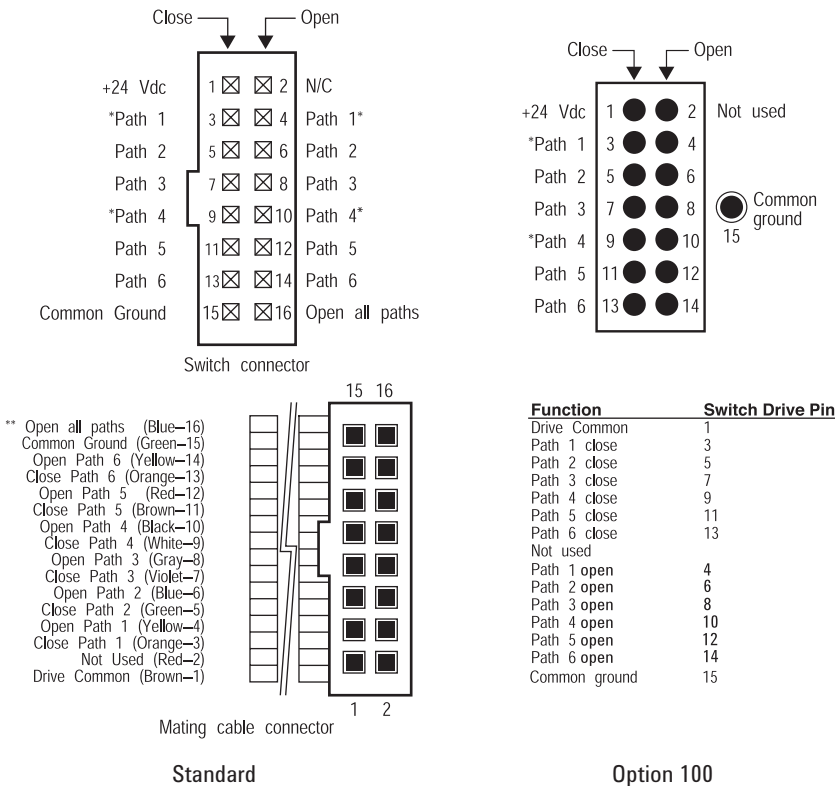

Warning:

1. Grounding both a “close” an “open” pin of the same path simultaneously will cause rapid cycling and premature failure of the switch.
2. Grounding any “close” pin and pin 16 simultaneously will cause rapid cycling and premature failure of the switch.

* Paths 1 and 4 not connected for the 87204A/B/C.
 ** “Open all paths” is not available with Option 100.

Figure 8. Drive connection diagrams

Troubleshooting

Symptom	Probable cause
1. Will not switch	<ul style="list-style-type: none"> - Not connected to supply - Supply < 20 V - Insufficient supply current - Pin 15 not connected to ground - Select line not at ground
2. Switch buzzes	<ul style="list-style-type: none"> - “Open” and “close” pins on same RF path are selected simultaneously - Pin 16 and any “closed” pins are selected simultaneously

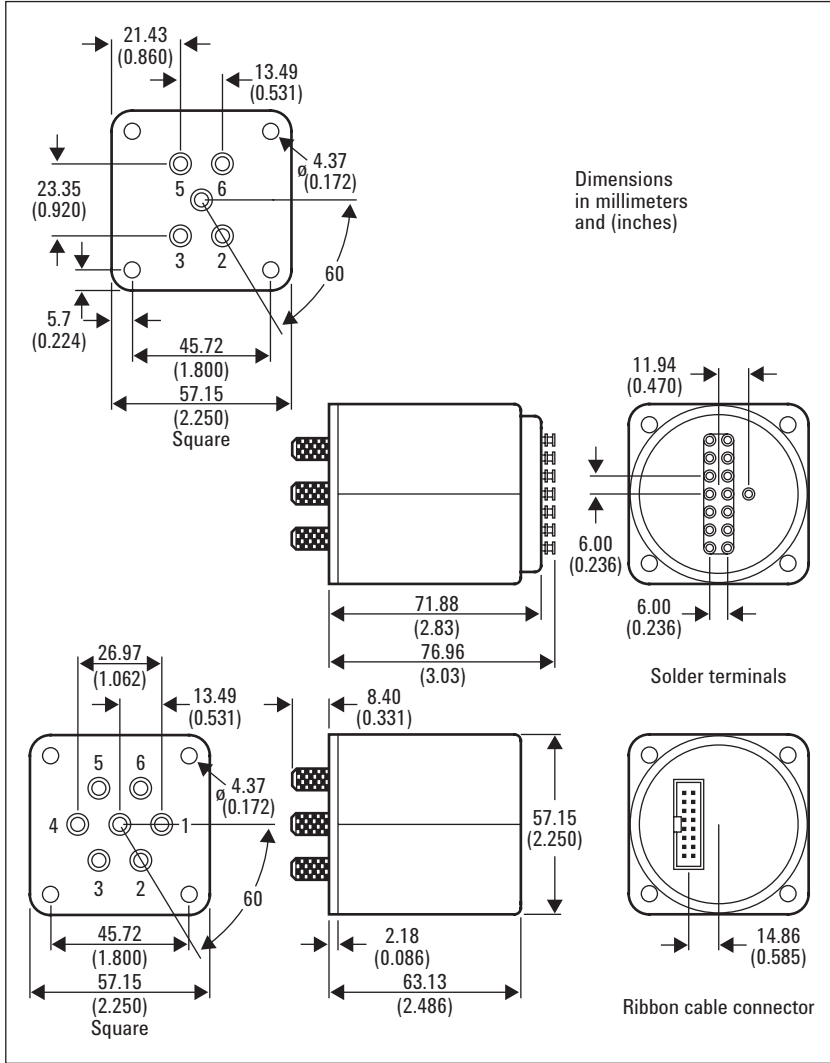

Figure 9. Product outlines

Ordering information

Switches	
87204A	dc to 4 GHz, SP4T terminated
87204B	dc to 20 GHz, SP4T terminated
87204C	dc to 26.5 GHz, SP4T terminated
87206A	dc to 4 GHz, SP6T terminated
87206B	dc to 20 GHz, SP6T terminated
87206C	dc to 26.5 GHz, SP6T terminated
Option 100	Solder terminals to replace ribbon cable
Option 161	16-pin DIP socket and connector with 24-inch ribbon cable
Option UK6	Test data for commercial calibration with certificate

Note: 24 Vdc and Option 161 are default options for dc drive and connector option.

Drivers	
11713B Attenuator switch driver	Drives up to 10 sections of switches or attenuators.
5061-0969 Accessory cable	Viking connector to bare tinned wires (60 inches long). Use to connect 11713B to 87204/206 with Option 100. One required with 87204 Option 100; two required with 87206 Option 100.
70611A Attenuator/switch driver	When expanded with up to 8 external (standard only) 84940A driver cards, the 70611A will drive up to 248 switch or attenuator sections. See below for accessories.

Related literature

Publication title	Pub number
Keysight RF and Microwave Switch Selection Guide	5989-6031EN

myKeysight

myKeysight

www.keysight.com/find/mykeysight

A personalized view into the information most relevant to you.



www.axiestandard.org

AdvancedTCA® Extensions for Instrumentation and Test (AXIe) is an open standard that extends the AdvancedTCA for general purpose and semiconductor test. Keysight is a founding member of the AXIe consortium.



www.lxistandard.org

LAN eXtensions for Instruments puts the power of Ethernet and the Web inside your test systems. Keysight is a founding member of the LXI consortium.



www.pxisa.org

PCI eXtensions for Instrumentation (PXI) modular instrumentation delivers a rugged, PC-based high-performance measurement and automation system.



Three-Year Warranty

www.keysight.com/find/ThreeYearWarranty

Keysight's commitment to superior product quality and lower total cost of ownership. The only test and measurement company with three-year warranty standard on all instruments, worldwide.



Keysight Assurance Plans

www.keysight.com/find/AssurancePlans

Up to five years of protection and no budgetary surprises to ensure your instruments are operating to specification so you can rely on accurate measurements.



www.keysight.com/quality

Keysight Electronic Measurement Group
DEKRA Certified ISO 9001:2008
Quality Management System

Keysight Channel Partners

www.keysight.com/find/channelpartners

Get the best of both worlds: Keysight's measurement expertise and product breadth, combined with channel partner convenience.

www.keysight.com/find/mta

For more information on Keysight Technologies' products, applications or services, please contact your local Keysight office. The complete list is available at: www.keysight.com/find/contactus

Americas

Canada	(877) 894 4414
Brazil	55 11 3351 7010
Mexico	001 800 254 2440
United States	(800) 829 4444

Asia Pacific

Australia	1 800 629 485
China	800 810 0189
Hong Kong	800 938 693
India	1 800 112 929
Japan	0120 (421) 345
Korea	080 769 0800
Malaysia	1 800 888 848
Singapore	1 800 375 8100
Taiwan	0800 047 866
Other AP Countries	(65) 6375 8100

Europe & Middle East

Austria	0800 001122
Belgium	0800 58580
Finland	0800 523252
France	0805 980333
Germany	0800 6270999
Ireland	1800 832700
Israel	1 809 343051
Italy	800 599100
Luxembourg	+32 800 58580
Netherlands	0800 0233200
Russia	8800 5009286
Spain	0800 000154
Sweden	0200 882255
Switzerland	0800 805353
	Opt. 1 (DE)
	Opt. 2 (FR)
	Opt. 3 (IT)
United Kingdom	0800 0260637

For other unlisted countries:
www.keysight.com/find/contactus
(BP-06-09-14)

