

Keysight 87406B

Coaxial Matrix Switch

DC to 20 GHz

Technical Overview

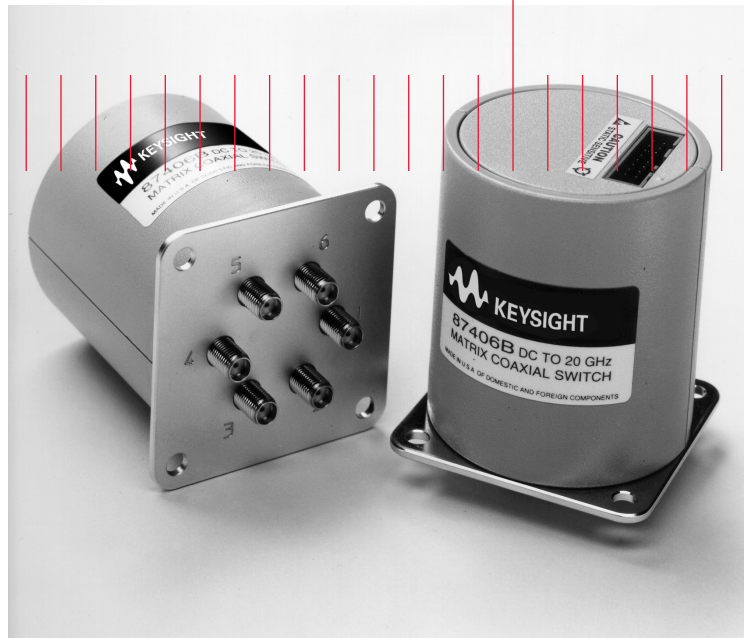

Modern automated test systems demand higher accuracy and performance than ever before. The Keysight Technologies, Inc. 87406B matrix switch offers improvements in insertion loss repeatability and isolation necessary to achieve higher test system performance. Long life, excellent repeatability, and high reliability lowers the cost of ownership by reducing calibration cycles and increasing test system uptime that are vital to ATS measurement system integrity.

Description

The 87406B matrix switch provides the life and reliability required for automated test and measurement, signal monitoring, and routing applications. Innovative design and careful process control creates a switch that meets the requirements for highly repeatable switching elements in test instruments and switching interfaces. The switch is designed to operate for more than 10 million cycles and will meet all electrical specifications for at least 5 million cycles.

High Performance Matrix Switch for RF and Microwave Test Systems

- 3 x 3, 2 x 4, and 1 x 5 blocking matrix configurations
- Magnetic latching
- Make-before-break or break-before-make operation
- Operating life of 10 million cycles, typical
- Guaranteed repeatability of 0.03 dB up to 5 million cycles
- Excellent isolation, typically >100 dB at 20 GHz
- Opto-electronic indicators and interrupts
- Terminated ports
- TTL/5V CMOS compatible (optional)

The switch exhibits exceptional insertion loss repeatability. This reduces sources of random errors in the measurement path and improves measurement uncertainty. Switch life is a critical consideration in production test systems, satellite and antenna monitoring systems, and test instrumentation. The longevity of the switch increases system uptime, and lowers the cost of ownership by reducing calibration cycles and switch maintenance.

Operating to 20 GHz, this switch exhibits the exceptional isolation performance required to maintain measurement integrity. Isolation between ports is typically > 100 dB to 20 GHz. This reduces the influence of signals from other channels, sustains the integrity of the measured signal, and reduces system measurement uncertainties. This switch also minimizes measurement uncertainty with low insertion loss and reflection, which makes it an ideal element in large, multi-tiered switching systems.

The 87406B is designed to fall within most popular industry footprints. The 2¼ inch square flange provides

mounting holes, while the rest of the 2½ inch long by 2¼ inch diameter body will easily fit into most systems. Ribbon cable or optional solder terminal connections accommodate the need for secure and efficient control cable attachment. Option 100 provides solder terminal connections in place of the 16-pin ribbon drive cable. Option 100 does not incorporate the "open all paths" feature.

Opto-electronic interrupts and indicators improve reliability and extend the life of the switch by eliminating DC circuit contact failures characteristic of conventional electromechanical switches. This switch has an interrupt circuit that provides logic to open all but the selected ports, then closes the selected ports and the current to all the solenoids is then cut off. This switch also offers independent indicators that are controlled by optical interrupts in the switch. The indicators provide a connection between the indicator common pin and the corresponding sense pin of the selected port.

All unselected RF ports are terminated with 50 ohm loads.

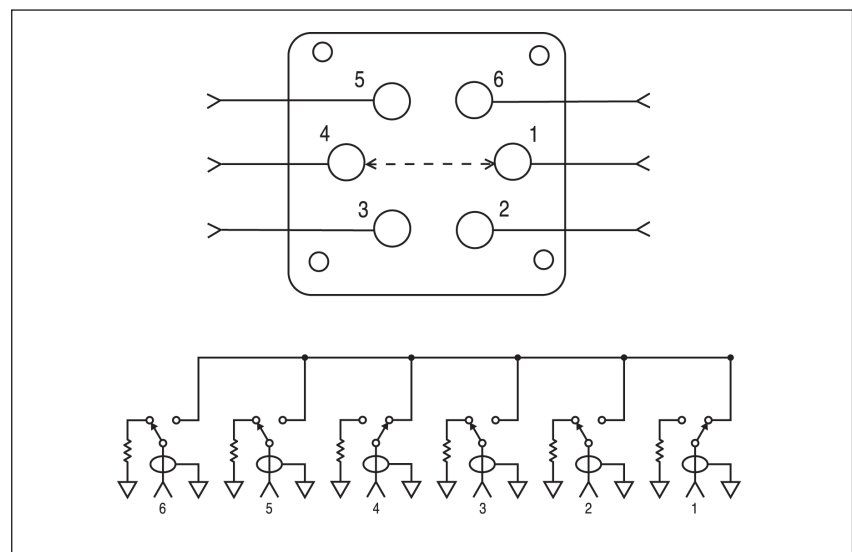

Figure 1. Keysight 87406B connection diagram and simplified schematic (RF path 4 to 1 shown)

Applications

Matrix signal routing

Figures 2 and 3 show the 87406B configured for blocking 2 x 4 and 3 x 3 applications. With outstanding repeatability and life greater than 5 million cycles, these switches enhance measurement confidence and reduce cost of ownership. In addition, the matrix switch has the

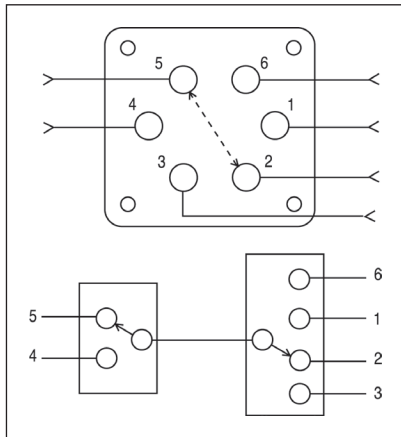

Figure 2. Matrix switch configured for a 2 x 4 blocking application (RF Path 5 to 2 shown)

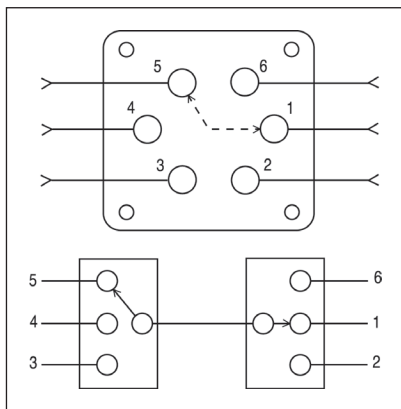

Figure 3. Matrix switch configured for a 3 x 3 blocking application (RF Path 5 to 1 shown)

versatility to provide single pole multiple throw signal routing up to 1 x 5 (SP5T). For applications requiring only single pole multiple throw signal routing, the 87104 and 87106 series high performance switches are recommended. Information on switch drivers can be found on page 9 of this document. For additional information, request one of the configuration guides listed in the *Related Literature* section on page 11 of this document.

General operation

The 87406B matrix switch consists of 6 ports which can be individually connected via internal microwave switches to form an RF path (see Figure 4). When control inputs are sent to the switch, the internal diode logic and position sensing circuitry routes current to the appropriate solenoids to close or open the microwave switches based on the input state. The position sensing circuitry utilizes opto-electronic components to determine the position of the individual internal microwave switches. Each internal microwave switch has two solenoids: one to select or close the RF port, and one to unselect or open the RF port.

Each solenoid requires 200 mA @ 24 VDC nominal. The position sensing circuits serve three purposes: to enable solenoids that need to be switched, to interrupt the solenoid current once the individual internal microwave switch is closed or opened, and to power the position indicator circuits. The solenoid current is interrupted once the switching solenoids are magnetically latched. The drive current then returns to the standby level that is required by the opto-electronic components. When a control input is applied, all RF ports that have no enabling control input are automatically opened by the internal logic circuitry.

To configure a desired RF path, two ports must be engaged which requires a control input for each port to be maintained. If the input is removed from either port, that port will be automatically opened by the internal logic circuitry. All of the "open" solenoids are internally connected to pin 16 via diode logic circuitry (Option 161 and T24 only). If no input is present at any of the port select pins (3, 5, 7, 9, 11, 13), all of the RF ports will be opened if pin 16 is selected.

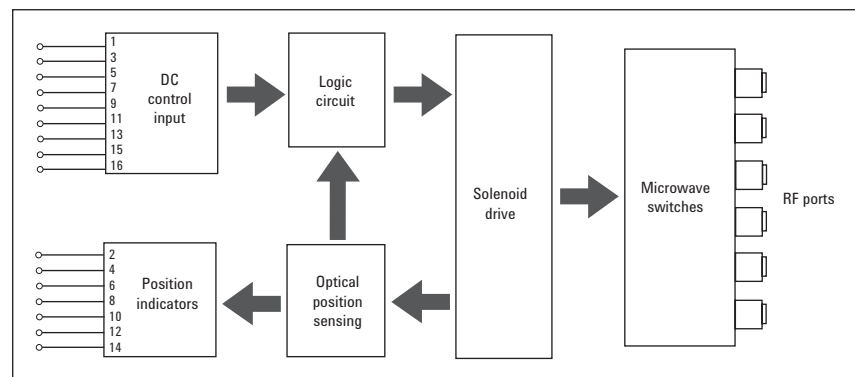

Figure 4. Keysight 87406B block diagram

General operation (Continued)

Input applied to port select pins (3, 5, 7, 9, 11, 13) while pin 16 is selected will override the signal on pin 16 and close the respective ports. On standard switches, pin 16 can be permanently connected to ground to allow the switch to open all RF ports at power up (assuming no input is present at any of the port select pins). Not available with Options 100 or T24.

If pin 15 is not grounded, the logic circuit will not operate as expected, and damage to the switch will occur.

Driving the Switch

DC power connection

- Connect pin 1 to supply (+20 VDC to +32 VDC)
- Connect pin 15 to chassis ground to enable the electronic position-indicating circuitry and drive logic circuitry.

Warning: Damage to switch will occur if pin 15 is not grounded.

RF path selection

To connect any two RF ports, apply control signal to the corresponding drive pins as shown below.

Table 1. Keysight 87406B RF port drive pin control data (see Figure 8 for drive connection diagrams.)

RF port	6	5	4	3	2
1	3, 13	3, 11	3, 9	3, 7	3, 5
2	5, 13	5, 11	5, 9	5, 7	
3	7, 13	7, 11	7, 9		
4	9, 13	9, 11			
5		11, 13			

Using Table 1, **select** (close) the desired RF path by connecting ground (Option 024 and Option 100) or applying TTL “High” (Option T24) to the corresponding “drive” pins.

Clear (open) RF paths by disconnecting ground (Option 024 and Option 100) or applying TTL “Low” (Option T24) to the corresponding “drive” pins.

Example: Configure the RF path from port 2 to port 5

Using the data in Table 1, select pins 5 and 11 while ensuring no other pins are selected.

RF port	1	2	3	4	5	6	Open all*
Drive pin	3	5	7	9	11	13	16
Option 024, Option 100	U	G	U	U	G	U	X**
Options T24, 100	L	H	L	L	H	L	X**

U = Ungrounded, G = Grounded, L = TTL “Low”, H = TTL “High”, X = Don’t care

* “Open All Ports” is not available with Option 100 or Option T24.

** “Open all RF Ports” feature is overridden by port selection.

Selected ports will be closed and unselected ports will be automatically opened by the internal logic circuits when new port selections are made. After the RF port is switched and magnetically latched, the solenoid current is interrupted by the solid-state position sensing circuitry. The drive voltage must be maintained to avoid RF path disconnection by the internal logic. For this reason, **pulsed drive is NOT recommended**. Use the 87606B if pulse drive, such as used on 70611A or 87130A, is desired.

Open all RF ports

Unselecting all RF ports and selecting Pin 16 on standard and Option T24 opens all RF ports:

Drive pin	3	5	7	9	11	13	16
Option 024	U	U	U	U	U	U	G
Option T24	L	L	L	L	L	L	H

U = Ungrounded, G = Ground, L = TTL "Low", H = TTL "High"

Selecting an RF port will override the "open all RF ports" for each selected port. If desired, pin 16 can be wired directly to ground (Option 024) or TTL "High" (Option T24) to open all RF ports at power-up.

Break-before-make

Remove the control inputs from the undesired port, then select the desired port. The internal logic will unselect the old port automatically upon application of the new port selection.

Make-before-break

Select the new RF port while maintaining the control input on the original ports. Allow 15 ms for the switching action to be completed, then unselect the original port; the original port will be automatically disconnected by the internal logic.

Electronic Position Indicators

The electronic position indicators consist of optically isolated, solid state relays that are driven by photoelectric sensors coupled to the mechanical position of the RF ports moving elements (Figure 5). The circuitry consists of a common that can be connected to an output corresponding to each RF port. When multiple RF ports are engaged, the position indicator corresponding to each closed RF port will be connected to common. The solid state relays are configured for AC and/or DC operation. (See indicator specifications.) The electronic position indicators require that the supply (20–32 VDC) be connected to pin 1 and ground connected to pin 15.

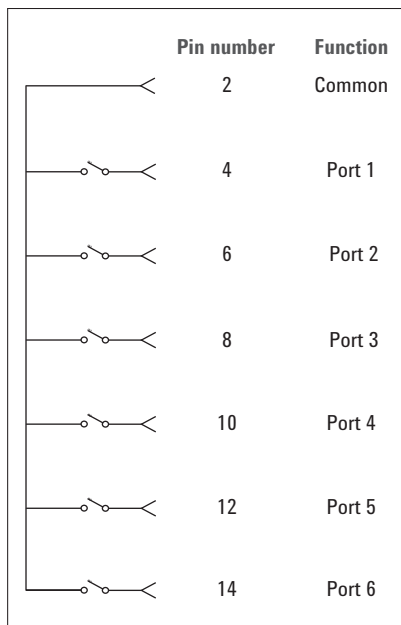

Figure 5. Indicator function diagram

Specifications

Specifications describe the instrument’s warranted performance. **Supplemental** and **typical characteristics** are intended to provide information useful in applying the instrument by giving typical, but not warranted performance parameters.

Maximum power rating	
Into internal termination	1W CW 50 W peak, 10 μ s max pulse width, not to exceed 1 W average
Into thru path	
Hot switching	2 W CW 100 W peak, 10 μ s max pulse width, not to exceed 2 W average
Cold switching	See “Supplement Specifications (Cold Switching)”
Life	5,000,000 cycles minimum
Switching time	15 ms maximum
Indicator specifications (@ 25 °C)	
Maximum withstand voltage	60 V
Maximum current capacity	150 mA
Maximum “ON” resistance	2.5 Ω
Typical “OFF” resistance	10 G Ω

Supplemental Specifications (Cold Switching)

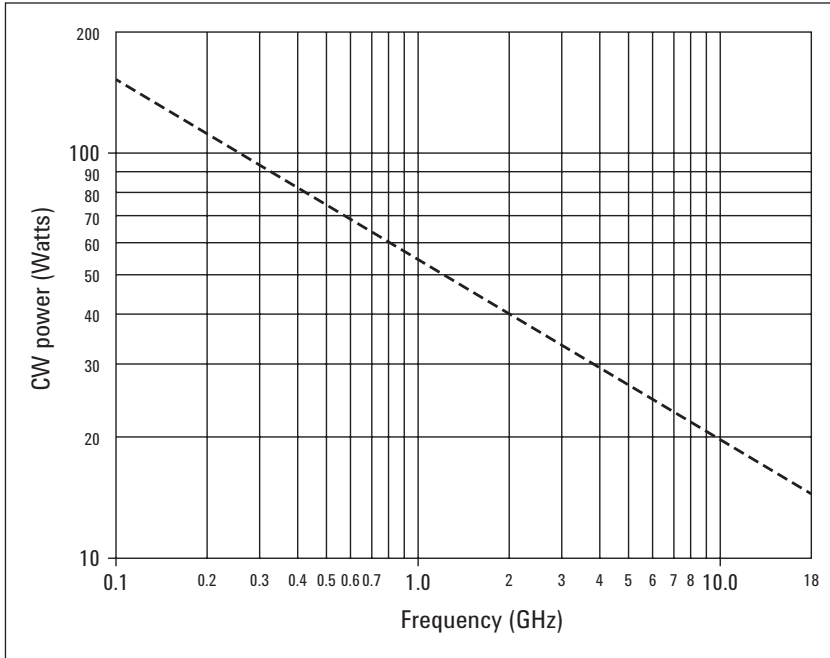

Supplemental characteristics

Insertion loss repeatability (measured at 25 °C)	0.03 dB
Characteristic impedance	50 ohms
RF connectors	SMA (f)

Reference conditions:

- Cold switching only (NO Hot switching)
- Ambient temperature of 75 °C or less
- Sea level (0.88 derating @ 15,000 ft.)
- Load VSWR < 1.2 (see graph for derating above 1.2 VSWR)
- Power Handling at 25 °C is 100 W at 4 GHz

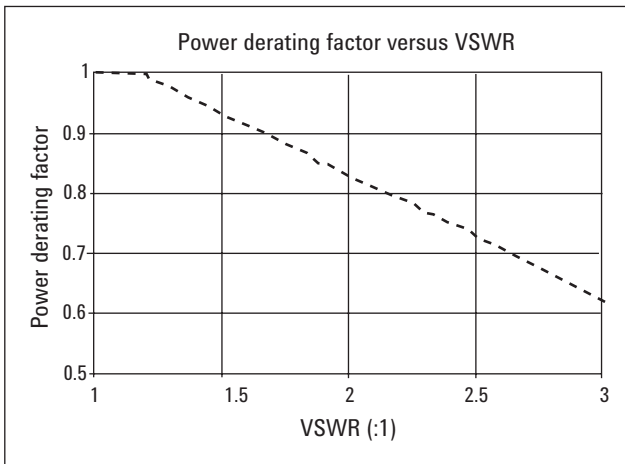

Specifications (Continued)

Switch drive specifications

Parameter	Conditions	Min	Nom	Max	Units
Supply voltage, Vcc		20	24	32	V
Switching current	Vcc = 24 VDC		200 ¹		mA
Standby current (quiescent)		25		50	mA
Options T24/100					
High level input		3		7	V
Low level input				0.8	V
Max high input current	Vcc = Max; Vinput = 3.85 VDC		1	1.4	mA

¹200 mA is required for each RF port closed or open. Using "open all ports" (pin 16) will require up to 1200 mA (6 ports times 200 mA each). See General Operation Section, page 3.

Frequency range	dc to 20 GHz
Insertion loss	0.34 dB + 0.033 x frequency (GHz) maximum
Isolation	100 dB minimum to 12 GHz 80 dB minimum from 12 to 15 GHz 70 dB minimum from 15 to 20 GHz
SWR	1.21 maximum from dc to 4 GHz 1.35 maximum from 4 to 10 GHz 1.5 maximum from 10 to 15 GHz 1.7 maximum from 15 to 18 GHz 1.9 maximum from 18 to 20 GHz

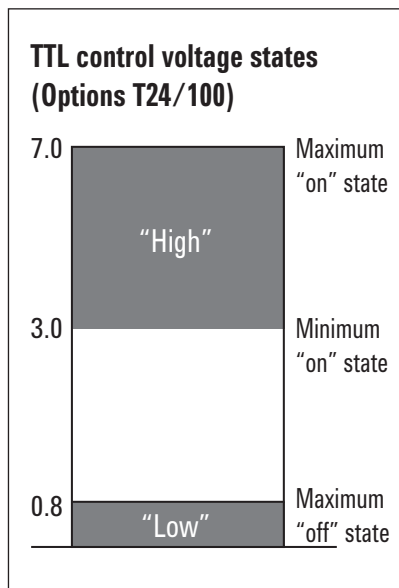

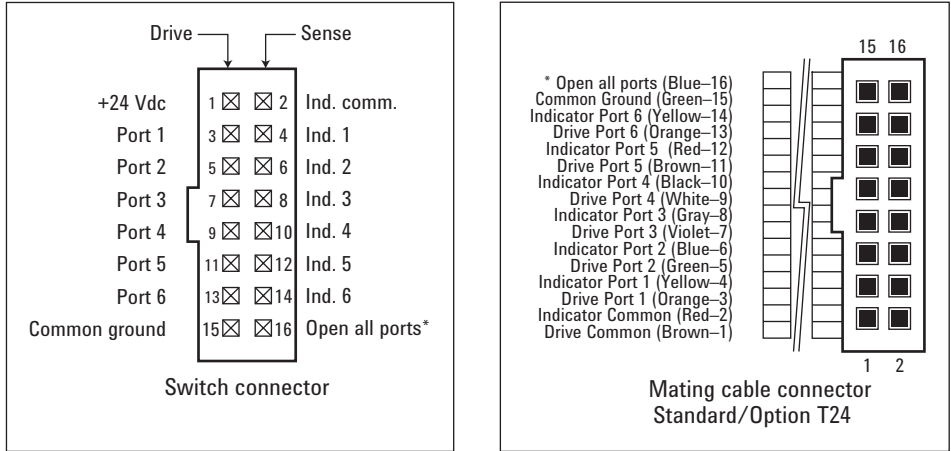

* Open all ports pin is not available with Options 100/T24.1516Common

Figure 6. J1 connector configuration

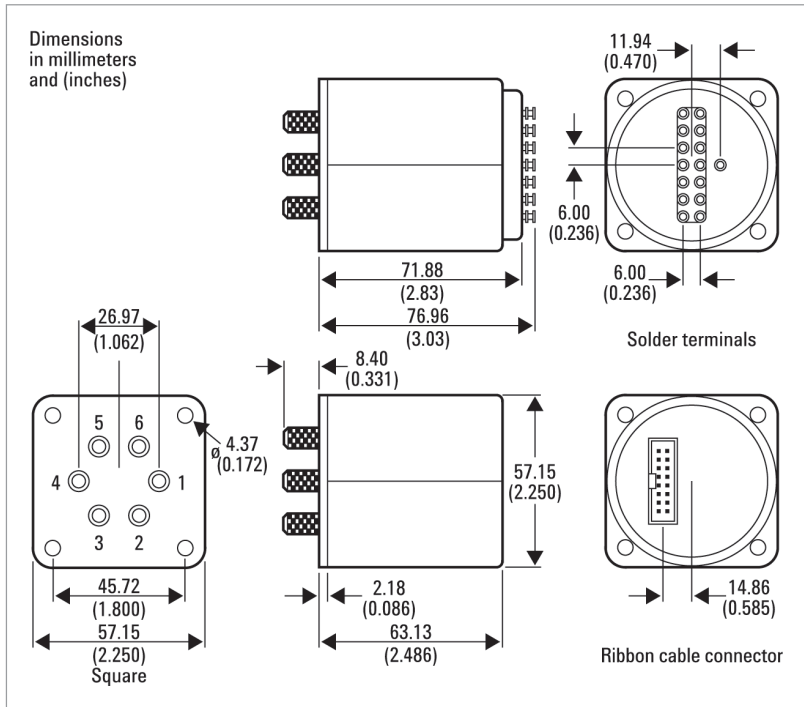

Figure 7. Product outline

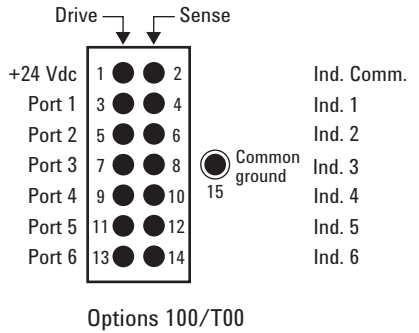

Figure 8. Drive connection diagrams

Environmental specifications	
Operating temperature	-25 to 75 °C
Storage temperature	-55 to 85 °C
Temperature cycling	-55 to 85 °C, 10 cycles per MIL-STD-202F, Method 107D, Condition A (modified)
Vibration	
Operating	7 g: 5 to 2000 Hz at 0.25 in p-p
Survival	20 g: 20 to 2000 Hz at 0.06 in p-p, 4 min/cycle, 4 cycles/axis
Random	2.41 g (rms) 10 min/axis
Shock	
Half-sine	500 g at 0.5 ms, 3 drops/direction, 18 total
Operating	50 g at 6 ms, 6 directions
Moisture resistance	65 °C, 95% RH, 10 days per MIL-STD-202F, Method 106E
Altitude storage	50,000 feet (15,240 meters per MIL-STD-202F, Method 105C, Condition B)
RFI	Per MIL-STD-461C, RE02, Part 4
Magnetic field	<5 gauss ¼ inch from surface

Physical specifications	
Dimensions	Per Figure 7
Weight	229 gm (0.50 lb)

Troubleshooting

Symptom	Probable cause
1. Will not switch	<ul style="list-style-type: none"> - Not connected to supply - Supply < 20 V - Supply current too low - Not connected to ground - Select line not at ground (std) - TTL "Low" voltage too high (Options T24)
2. Position indicators don't work	<ul style="list-style-type: none"> - Supply not connected - Supply < 20 VDC - Pin 15 not connected to ground

Ordering information

Coaxial matrix switch	
87406B	Coaxial matrix switch DC to 20 GHz
Options	
To add options to a product, use the following scheme:	
Model	87406B
Model options	87406B-Opt #1 87406B-Opt #2
DC connectors (must choose one)	
87406B-161	16-pin DIP with quantity (one) ribbon cable, 24" with SMA female connector
87406B-100	Solder terminals
Control Logic (must choose one)	
87406B-T24	TTL and 5 V CMOS compatibility
87406B-024	24 V DC without TTL Logic
<i>Note: Options 024 and 161 are default options for dc drive and connector.</i>	
Calibration documentation (optional)	
87406B-UK6	Calibration data
Drivers	
11713B/C Attenuator switch driver	Drives up to 10 or 20 sections of switches or attenuators.
5061-0969 Accessory cable	Viking connector to bare tinned wires (60 inches long). Use (2) 5061-0969 to connect the 11713B/C to the 87406B Option 100 switch.

Related literature

Publication title	Pub number
<i>Keysight 11713B/C Attenuator/Switch Drivers Configuration Guide</i>	5989-7277EN
<i>Keysight RF and Microwave Switch Selection Guide</i>	5989-6031EN
<i>Power Handling Capability of Electromechanical Switches Application Note</i>	5989-6032EN
<i>Coaxial Electromechanical Switches: How Operating Life and Repeatability of Keysight's Electromechanical Switches Minimize System Uncertainty Application Note</i>	5989-6085EN

myKeysight

myKeysight

www.keysight.com/find/mykeysight

A personalized view into the information most relevant to you.



www.axiestandard.org

AdvancedTCA® Extensions for Instrumentation and Test (AXIe) is an open standard that extends the AdvancedTCA for general purpose and semiconductor test. Keysight is a founding member of the AXIe consortium.



www.lxistandard.org

LAN eXtensions for Instruments puts the power of Ethernet and the Web inside your test systems. Keysight is a founding member of the LXI consortium.



www.pxisa.org

PCI eXtensions for Instrumentation (PXI) modular instrumentation delivers a rugged, PC-based high-performance measurement and automation system.



Three-Year Warranty

www.keysight.com/find/ThreeYearWarranty

Keysight's commitment to superior product quality and lower total cost of ownership. The only test and measurement company with three-year warranty standard on all instruments, worldwide.



Keysight Assurance Plans

www.keysight.com/find/AssurancePlans

Up to five years of protection and no budgetary surprises to ensure your instruments are operating to specification so you can rely on accurate measurements.



www.keysight.com/quality

Keysight Technologies, Inc.
DEKRA Certified ISO 9001:2008
Quality Management System

Keysight Channel Partners

www.keysight.com/find/channelpartners

Get the best of both worlds: Keysight's measurement expertise and product breadth, combined with channel partner convenience.

ATCA®, **AdvancedTCA®**, and the **ATCA logo** are registered US trademarks of the PCI Industrial Computer Manufacturers Group.

www.keysight.com/find/mta

For more information on Keysight Technologies' products, applications or services, please contact your local Keysight office. The complete list is available at: www.keysight.com/find/contactus

Americas

Canada	(877) 894 4414
Brazil	55 11 3351 7010
Mexico	001 800 254 2440
United States	(800) 829 4444

Asia Pacific

Australia	1 800 629 485
China	800 810 0189
Hong Kong	800 938 693
India	1 800 112 929
Japan	0120 (421) 345
Korea	080 769 0800
Malaysia	1 800 888 848
Singapore	1 800 375 8100
Taiwan	0800 047 866
Other AP Countries	(65) 6375 8100

Europe & Middle East

Austria	0800 001122
Belgium	0800 58580
Finland	0800 523252
France	0805 980333
Germany	0800 6270999
Ireland	1800 832700
Israel	1 809 343051
Italy	800 599100
Luxembourg	+32 800 58580
Netherlands	0800 0233200
Russia	8800 5009286
Spain	0800 000154
Sweden	0200 882255
Switzerland	0800 805353
	Opt. 1 (DE)
	Opt. 2 (FR)
	Opt. 3 (IT)
United Kingdom	0800 0260637

For other unlisted countries:
www.keysight.com/find/contactus
(BP-06-23-14)

