

Installation Note

11884C 6 GHz Operation Upgrade Kit for the 8753D Option 011 Network Analyzer



Agilent Technologies

Part Number 08753-90266 Supersedes August 1998

Printed in USA August 2001

Notice.

The information contained in this document is subject to change without notice.

Agilent Technologies makes no warranty of any kind with regard to this material, including but not limited to, the implied warranties of merchantability and fitness for a particular purpose. Agilent Technologies shall not be liable for errors contained herein or for incidental or consequential damages in connection with the furnishing, performance, or use of this material.

11884C 6 GHz Operation Upgrade Kit

Product Affected

8753D Option 011 Network Analyzer

To Be Performed by:

[X] Agilent Technologies Qualified
Personnel

Purpose

The 11884C 6 GHz upgrade kit provides the 8753D Option 011 Network Analyzer with optional 6 GHz operation. The upgrade kit is keyed to the serial number of an individual network analyzer.

Items Included in the Kit

Table 1 describes the parts included in the 11884C upgrade kit. Check the contents of the kit against this table.

Table 1 **11884C Upgrade Kit Contents**

Quantity	Description
1	6 GHz source assembly
1	Customer letter
1	6 GHz registration number label
1	Keyword label
1	Installation note
1	Option installation label
1	6 GHz Nameplate

Equipment and Tools Required

Table 2 Required Equipment and Tools

Item	Part or Model Number
Power meter	436A/437B/438A
Power sensor	8482A
Power sensor	8481A
Power Splitter, 2 way 50Ω (2)	8481A
Frequency counter	5350B
Cable Set, RF 24-inch	11500B
Cable Set, RF 50Ω Type-N	11851B
Cable, BNC-to-BNC	8120-1840
Adapter, Type-N (f) to BNC (m)	1250-0077
Adapter, Type-N (m) to Type-N (m)	1250-1475
Adapter, Type-N (f) to Type-N (f)	1250-1472
Adapter, Type-N (m) to SMA (f)	1250-1250
Adapter, Type-N (f) to SMA (m)	1250-1562
Adapter, BNC Alligator clip	8120-1292
GPIB cable assembly	10833A
Low-pass filter	9135-0198
Attenuator, 10 dB (Option 002 only)	8491A Option 010
Attenuator, 20 dB (2)	8491A Option 020
Attenuator, 30 dB (Option 002 only)	8491A Option 030
3.5-inch floppy disk	92192A (box of 10)
Small needle-nose pliers	
T-10 TORX screwdriver	
T-15 TORX screwdriver	
5/16 inch open-end wrench	
5/16 inch torque wrench (10 in-lbs)	
Electrostatic discharge (ESD) grounding wrist strap and mat	

Safety Considerations

WARNING **Before you disassemble the instrument, turn the power switch OFF and unplug the instrument. Failure to unplug the instrument can result in personal injury.**

CAUTION Electrostatic discharge (ESD) can damage or destroy electronic components. Perform these procedures only at a static-safe workstation and wear a grounding strap. Refer to the documentation that pertains to your instrument for information about static-safe workstations and ordering static-safe accessories.

Installation Procedure for the 8753D Option 011

Verify the Serial Number

Refer to the keyword label in the box below. Verify that the analyzer's serial number matches the serial number below. This keyword will not work on any other analyzer. If the serial numbers do not match, contact your nearest Agilent Technologies sales or service office for assistance.

Keyword Label

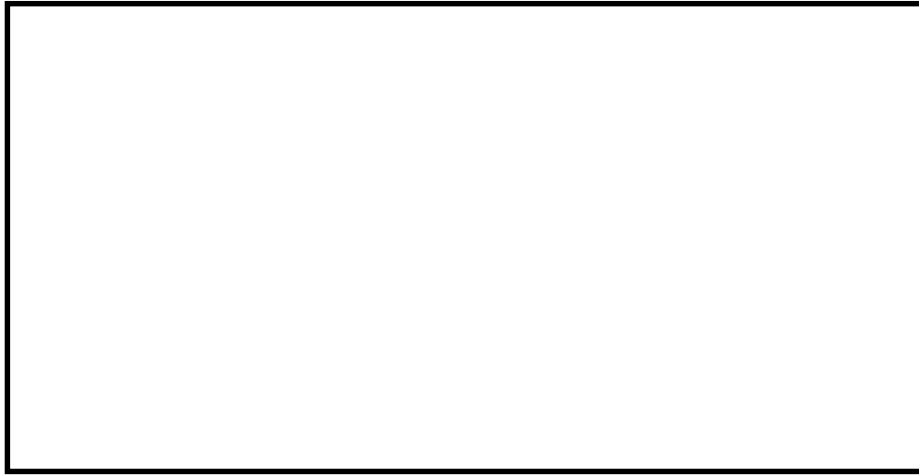

Remove the Feet and Covers

Refer to Figure 1.

1. Disconnect the power cord.
2. Remove the top cover:
 - a. Remove both of the upper rear feet (item 1) by loosening the attaching screws (item 2).
 - b. Loosen the top cover screw (item 3).
 - c. Slide the cover towards the back of the instrument.

Figure 1 **Cover and Feet Removal**

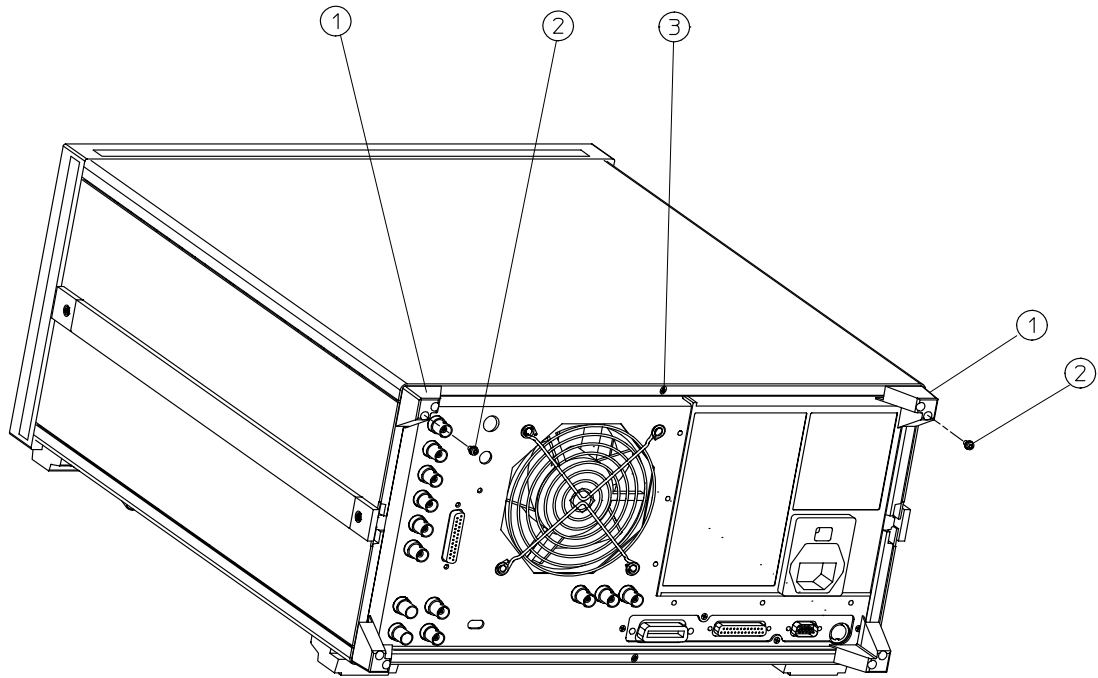

dg606d

Remove the 3 GHz Source Assembly

Refer to Figure 2

3. Remove the source bracket (item 4).
4. Disconnect the two semi-rigid cables (W1 and W24) and one flexible cable (W26) from the source assembly (A3).
5. Lift the two retention clips (item 5) at the front and rear of the source module to an upright position.
6. The source is seated in a motherboard edge connector. Hold the two loose semi-rigid cables (W1 and W24) to the right and gently pull up on the source bracket handle (item 6) to lift the source assembly out of the instrument.

Replace the Source

Refer to Figure 2.

7. Slide the edges of the sheet metal partition (item 7) of the 6 GHz source assembly into the guides at the front and back of the source compartment.
8. Press down on the assembly to ensure that it is well seated in the motherboard connector.
9. Push the retention clips down.
10. Reconnect the two semi-rigid cables (W1 and W24) and one flexible cable (W26) to the source assembly. Torque these connections to 10 in-lbs.
11. Replace the source bracket.

Figure 2 A3 Source Assembly Removal

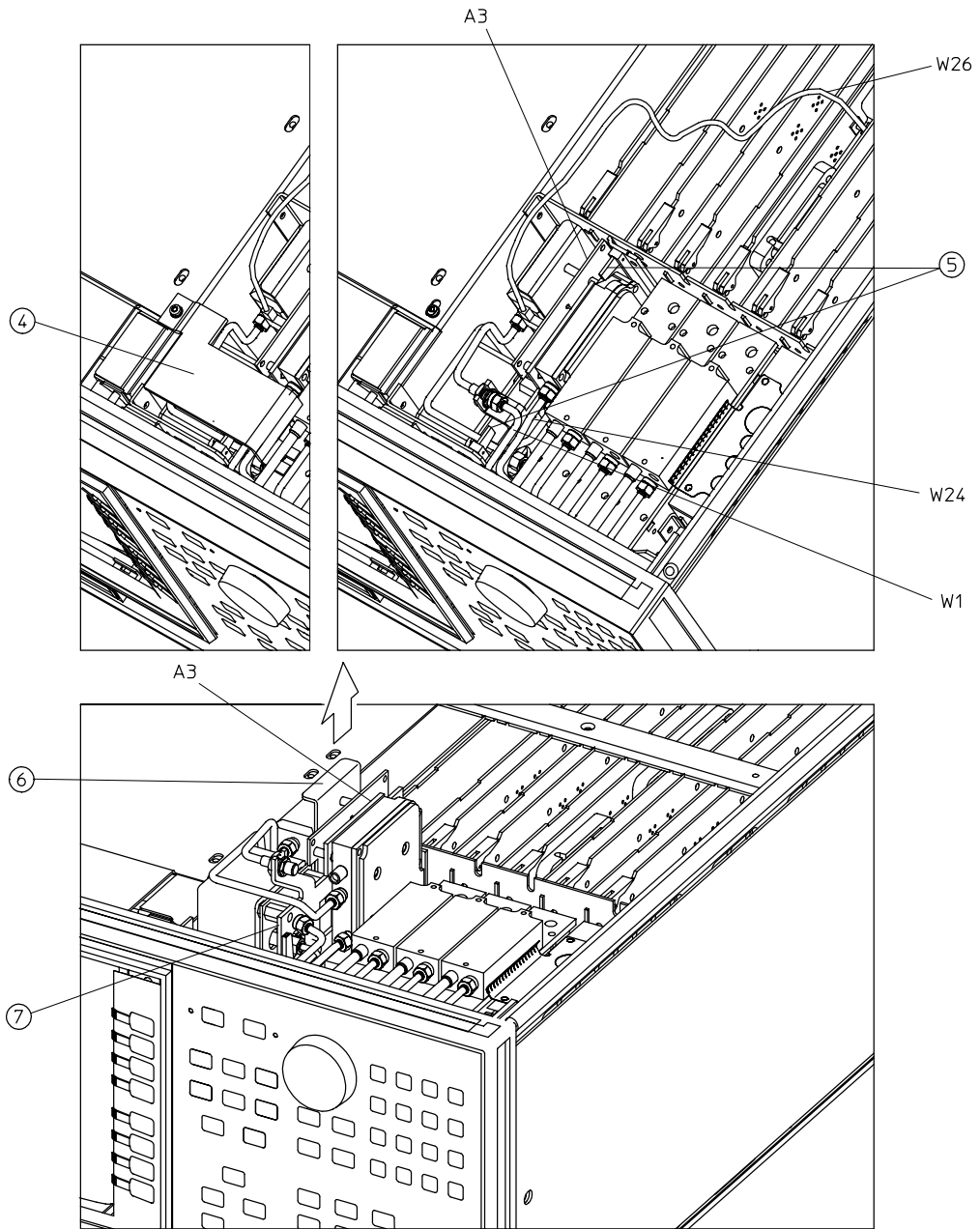

dg605

Configure the 8753D Option 011 for 6 GHz Operation

Refer to [Figure 3](#).

12. Remove the instrument bottom cover.

13. Move the A9 CC Jumper to the ALT position. Refer to [Figure 3](#).

Figure 3

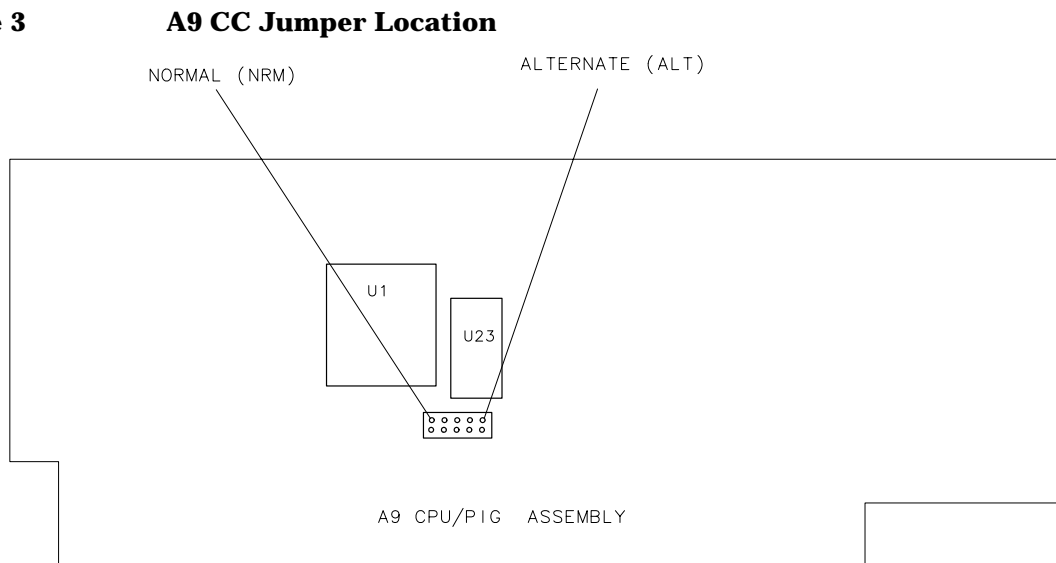

14. Switch on the power for the 8753D Option 011.

15. Press **PRESET**, **DISPLAY**, **MORE**, **TITLE**, **ERASE**, **TITLE** to erase the logo.

16. Enter the keyword from the label located on page 6. You may use an external keyboard or use the analyzer's front panel knob to position the arrow below each character of the keyword. Press **SELECT LETTER** to enter each character. When all characters are entered, press **DONE**.

17. Press **SYSTEM**, **SERVICE MENU**, **TESTS**, **56**, **x1**. At the prompt, press **EXECUTE TEST**, **YES**.

The analyzer will display Option Cor DONE when the test is complete.

18. Press **RETURN**, **TESTS**, **44**, **x1**. At the prompt, press **EXECUTE TEST**, **YES**.

The analyzer will display *Source Def DONE when the test is complete.

19. Press **RETURN**, **TESTS**, **45**, **x1**. At the prompt, press **EXECUTE TEST**, **YES**.

The analyzer will display *Pretune Def DONE when the test is complete.

20. Press **RETURN**, **TESTS**, **46**, **x1**. At the prompt, press **EXECUTE TEST**, **YES**.

The analyzer will display ABUS Cor DONE when the test is complete.

21. Press **RETURN**, **TESTS**, **48**, **x1**. At the prompt, press **EXECUTE TEST**, **YES**.

The analyzer will display Pretune Cor DONE when the test is complete.

22. Refer to "Adjustments" in the *8753D Network Analyzer Option 011 Service Guide* and perform the following adjustments:

- RF Output Power Correction Constants
- Sampler Magnitude and Phase Correction Constants
- Cavity Oscillator Frequency Correction Constants
- Source Spur Avoidance Tracking Adjustment
- EEPROM Backup Disk Procedure

23. Refer to "System Verification and Performance Tests" in the *8753D Network Analyzer Option 011 Service Guide* and perform the following system tests:

- Source Frequency Range and Accuracy
- Source Power Range, Linearity, and Accuracy
- Source and Receiver Harmonics (necessary only for analyzers with both Option 002 and 006)

24. Switch off the analyzer and disconnect the power cord. Move the A9 CC Jumper back to the NRM position.

Refer to [Figure 3](#).

Install the Keyword Label

Refer to [Figure 4](#).

25. Place the keyword label inside the instrument at the location shown.

Figure 4 **Option Keyword Label Location for the 8753D Option 011**

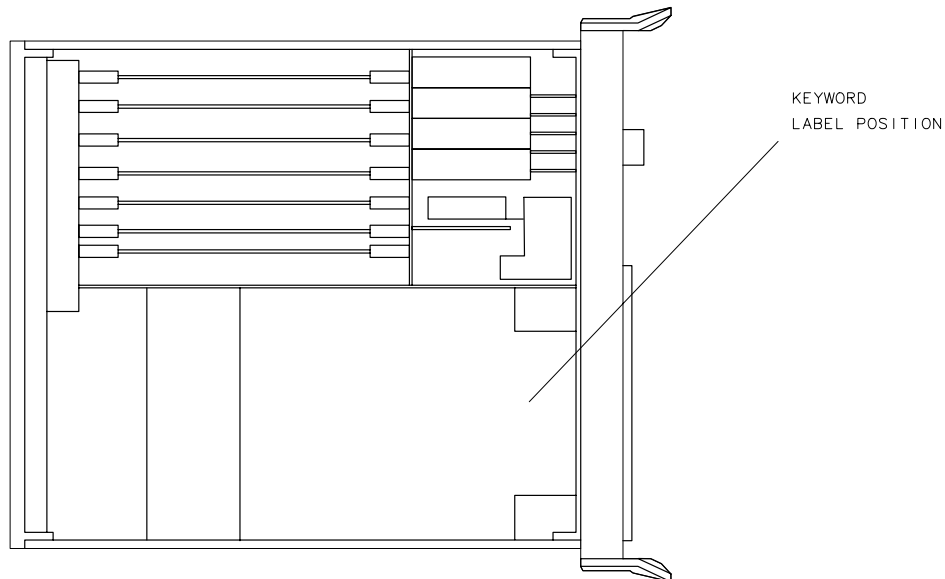

ur 74

Reassemble the Instrument

26. Replace the instrument top and bottom covers and all of the rubber feet.
27. Place the 11884C installation label on the rear panel of the network analyzer. Write the date of the installation in the space provided.

Replace the Analyzer's Nameplate

28. Use a sharp knife to slowly peel away the old nameplate.
 29. Adhere the new nameplate, which is included in the upgrade kit, onto the analyzer's front panel.
- This completes the 11884C 6GHz operation upgrade kit installation for the 8753D Option 011.

Contacting Agilent

By internet, phone or fax, get assistance with all your test and measurement needs.

Online assistance: www.agilent.com/find/assist