

Accessories for Keysight B2985B/B2987B

N1424A/B/C Resistivity Cell
N1425A/B Low Noise Test Leads
N1427A/B Low Noise Test Cables
N1428A Component Test Fixture

Notices

Copyright Notice

© Keysight Technologies 2021

No part of this manual may be reproduced in any form or by any means (including electronic storage and retrieval or translation into a foreign language) without prior agreement and written consent from Keysight Technologies as governed by United States and international copyright laws.

Manual Part Number

N1424-90100

Edition

Edition 1, April 2021

Published by:

Keysight Technologies Japan K.K.
9-1, Takakura-cho, Hachioji-shi, Tokyo
192-8550 Japan

Technology Licenses

The hardware and/or software described in this document are furnished under a license and may be used or copied only in accordance with the terms of such license.

Declaration of Conformity

Declarations of Conformity for this product and for other Keysight products may be downloaded from the Web. Go to <http://www.keysight.com/go/conformity>. You can then search by product number to find the latest Declaration of Conformity.

U.S. Government Rights

The Software is "commercial computer software," as defined by Federal Acquisition Regulation ("FAR") 2.101. Pursuant to FAR 12.212 and 27.405-3 and Department of Defense FAR Supplement ("DFARS") 227.7202, the U.S. government acquires commercial computer software under the same terms by which the software is customarily provided to the public. Accordingly, Keysight provides the Software to U.S. government customers under its standard commercial license, which is embodied in its End User License Agreement (EULA), a copy of which can be found at <http://www.keysight.com/find/sweula>. The license set forth in the EULA represents the exclusive authority by which the U.S. government may use, modify, distribute, or disclose the Software. The EULA and the license set forth therein, does not require or permit, among other things, that Keysight: (1) Furnish technical information related to commercial computer software or commercial computer software documentation that is not customarily provided to the public; or (2) Relinquish to, or otherwise provide, the government rights in excess of these rights customarily provided to the public to use, modify, reproduce, release, perform, display, or disclose commercial computer software or commercial computer software documentation. No additional government requirements beyond those set forth in the EULA shall apply, except to the extent that those terms, rights, or licenses are explicitly required from all providers of commercial computer software pursuant to the FAR and the DFARS and are set forth specifically in writing elsewhere in the EULA. Keysight shall be under no obligation to update, revise or otherwise modify the Software. With respect to any technical data as defined by FAR 2.101, pursuant to FAR 12.211 and 27.404.2 and DFARS 227.7102, the U.S. government acquires no greater than Limited Rights as defined in FAR 27.401 or DFAR 227.7103-5 (c), as applicable in any technical data.

Warranty

THE MATERIAL CONTAINED IN THIS DOCUMENT IS PROVIDED "AS IS," AND IS SUBJECT TO BEING CHANGED, WITHOUT NOTICE, IN FUTURE EDITIONS. FURTHER, TO THE MAXIMUM EXTENT PERMITTED BY APPLICABLE LAW, KEYSIGHT DISCLAIMS ALL WARRANTIES, EITHER EXPRESS OR IMPLIED, WITH REGARD TO THIS MANUAL AND ANY INFORMATION CONTAINED HEREIN, INCLUDING BUT NOT LIMITED TO THE IMPLIED WARRANTIES OF MERCHANTABILITY AND FITNESS FOR A PARTICULAR PURPOSE. KEYSIGHT SHALL NOT BE LIABLE FOR ERRORS OR FOR INCIDENTAL OR CONSEQUENTIAL DAMAGES IN CONNECTION WITH THE FURNISHING, USE, OR PERFORMANCE OF THIS DOCUMENT OR OF ANY INFORMATION CONTAINED HEREIN. SHOULD KEYSIGHT AND THE USER HAVE A SEPARATE WRITTEN AGREEMENT WITH WARRANTY TERMS COVERING THE MATERIAL IN THIS DOCUMENT THAT CONFLICT WITH THESE TERMS, THE WARRANTY TERMS IN THE SEPARATE AGREEMENT SHALL CONTROL.

Latest Information

To get the latest firmware/software/electronic manuals/specifications/support information, go to www.keysight.com and type in the product number in the Search field at the top of the page.

Safety Summary

The following general safety precautions must be observed during all phases of operation, service, and repair of this instrument. Failure to comply with these precautions or with specific warnings elsewhere in this manual may impair the protections provided by the instrument. In addition, it violates safety standards of design, manufacture, and intended use of the instrument. Keysight Technologies assumes no liability for customer's failure to comply with these requirements.

Product manuals may also be available on the Web. Go to www.keysight.com and type the product model number in the Search field at the top of the page. Manuals provided on CD-ROM or in printed form are an option for many products.

NOTE

Do not use this instrument in any manner not specified by the manufacturer. The protective features of this instrument may be impaired if it is used in a manner not specified in the operation instructions.

This instrument is an INDOOR USE product.

This instrument complies with OVERVOLTAGE CATEGORY II for mains input and POLLUTION DEGREE 2 defined in IEC 61010-1.

If an instrument is marked CAT I (IEC Measurement Category I), or it is not marked with a measurement category, its measurement terminals must not be connected to line-voltage mains.

WARNING

Hazardous voltage, instrument maximum output voltage may appear at high terminals if Interlock terminal is closed. Open the Interlock terminal when the high terminal is accessible. Voltage applied to the terminals will be limited up to ± 21 V.

Do not work the interlock function intentionally in order to bring the output voltage to the safe level. While the high voltage indicator is lit, the dangerous voltage by the output voltage or the residual charge appears on the measurement terminal.

- *DANGEROUS PROCEDURE WARNINGS*

Warnings, such as WARNING on the previous page, shall be complied. Procedures throughout in this manual prevent you from potentially hazard. Their instructions contained in the warnings must be followed.

- *BEFORE APPLYING POWER*

Verify that all safety precautions are taken. Make all connections to the instrument before applying power. Note the instrument's external markings described under "Safety Symbols".

- *GROUND THE INSTRUMENT*

This is Safety Class I instrument. To minimize shock hazard, the instrument chassis and cabinet must be connected to an electrical ground. The power terminal and the power cable must meet International Electrotechnical Commission (IEC) safety standards.

- *DO NOT OPERATE IN AN EXPLOSIVE ATMOSPHERE*

Do not operate the instrument in the presence of flammable gases or fumes. Operation of any electrical instrument in such an environment constitutes a definite safety hazard.

- *DO NOT REMOVE COVERS*

No operator serviceable parts inside. Refer servicing to qualified personnel. To prevent electrical shock do not remove covers.

- *IN CASE OF DAMAGE*

















Instruments that appear damaged or defective should be made inoperative and secured against unintended operation until they can be repaired by qualified service personnel. Return the instrument to a Keysight Technologies sales or service office for services and repair to ensure that safety features are maintained.

- *USE ONLY THE SPECIFIC ACCESSORIES*

Specific accessories satisfy the requirements for specific characteristics for using the instrument. Use the specific accessories, cables, adapters, and so on for safety reasons.

Safety Symbols

The general definitions of safety symbols used on equipment or in manuals are listed below.

-  Direct current.
-  Alternating current.
-  Earth ground terminal.
-  Protective conductor terminal. For protection against electrical shock in case of a fault. Used with field wiring terminals to indicate the terminal which must be connected to ground before operating equipment.
-  Frame or chassis terminal. A connection to the frame (chassis) of the equipment which normally includes all exposed metal structures.
-  Grounded terminal which indicates the earth potential.
-  On supply.
-  Off supply.
-  Standby supply. The equipment will be marked with this symbol is not completely disconnected from AC mains when power switch is in the standby position.
-  In position of a bi-stable push switch.
-  Out position of a bi-stable push switch.
-  Hazardous voltage and potential for electrical shock. Do not touch terminals that have this symbol when the equipment is on.
-  Hot surface. Avoid contact. Surfaces are hot and may cause personal injury if touched.
-  Low temperature or freezing conditions. Avoid contact. Surfaces are cold and may cause personal injury if touched.
-  Affixed to product containing static sensitive devices--use anti-static handling procedures to prevent electrostatic discharge damage to component.
-  Caution, refer to accompanying documentation. The equipment will be marked with this symbol when it is necessary for the user to refer to the instruction manual.
-  Read operator's manual. To indicate that the operator's manual or card should be read before continuing the operation.

CAT I IEC Measurement Category I

CE The CE mark shows that the product complies with all applicable European Directives.



The CSA mark is a registered trademark of the Canadian Standards Association.



The RCM mark is a registered trademark of the Australian Communications Authority. This signifies compliance with the Australian EMC Framework Regulations under the terms of the Radio communications Act.

ICES/NMB-001

This ISM device complies with Canadian ICES-001.
Cet appareil ISM est conforme à la norme NMB-001 du Canada.

ISM GROUP 1 CLASS A

This is the symbol for an Industrial, Scientific and Medical, Group 1 Class A product. (CISPR 11)



Korea's safety and EMC mark



China RoHS - Environmentally Green Product Label



China RoHS - Product with Toxic Substance 40 yr EPUP



The Chinese mark for paper-based packaging materials; Paperboard and Corrugated Fiberboard



Plastic Material Coding Identification

WARNING

A WARNING notice denotes a hazard. It calls attention to an operating procedure, practice, or the like that, if not correctly performed or adhered to, could result in personal injury or death. Do not proceed beyond a WARNING notice until the indicated conditions are fully understood and met.

CAUTION

A CAUTION notice denotes a hazard. It calls attention to an operating procedure, practice, or the like that, if not correctly performed or adhered to, could result in damage to the product or loss of important data. Do not proceed beyond a CAUTION notice until the indicated conditions are fully understood and met.



Contents

1 N1424A/B/C Resistivity Cell





General Information	12
Using the N1424A/B/C	12
Product Description	12
Operating and Safety Precautions	12
Preparation for Use	13
Initial Inspection	13
Ambient Environmental Considerations	14
Operating and Storage	14
⚠ Using the N1424A/B/C in an Environmental Test Oven	15
Exchanging the Electrode	16
⚠ To Change Electrodes	17
⚠ Connecting the Product for Use	18
Repackaging the Product	19
Operation	20
⚠ Product Features	20
⚠ Applying Contact Pressure	22
Making a Measurement	23
Removing the Upper Electrode	24
⚠ To Remove Upper Electrode	24
Care of the Electrodes	25
Checking Procedure	26
⚠ Daily Safety Verification Procedure	26





2 N1425A/B Low Noise Test Leads

General Information	28
Using the N1425A/B	28
Product Description	28
Operating and Safety Precautions	28
Preparation for Use	29

Initial Inspection	30
Ambient Environmental Considerations	30
Operating and Storage	30
 Connecting the Product for Use	30
Repackaging the Product	31
Operation	32
 Product Features	32
Making a Measurement	34
Pin Probes (N1426A)	35
Soldering Sockets (N1426B)	36
Checking Procedure	38
 Daily Safety Verification Procedure	38

3 N1427A/B Low Noise Test Cables

General Information	40
Using the N1427A/B	40
Product Description	40
Operating and Safety Precautions	40
Preparation for Use	41
Initial Inspection	41
Ambient Environmental Considerations	42
Operating and Storage	42
 Making a Custom Test Fixture	42
 Interlock Circuit	43
 Example Configuration of Custom Test Fixture	45
 Connecting the Product for Use	46
Repackaging the Product	47
Operation	48
 Product Features	48
Making a Measurement	49

	Checking Procedure.	50
	Daily Safety Verification Procedure	50
4	N1428A Component Test Fixture	
	General Information	54
	Using the N1428A	54
	Product Description	54
	Operating and Safety Precautions.	54
	Preparation for Use	55
	Initial Inspection.	55
	Ambient Environmental Considerations	55
	Operating and Storage.	55
	Connecting the Product for Use	57
	Exchanging the SMD Module or Flat Table.	58
	Setting Procedure.	58
	Removal Procedure	59
	Setup Image	59
	Repackaging the Product	60
	Operation.	61
	Product Features	61
	To Exchange Output Resistor	64
	Making a Measurement	65
	Checking Procedure.	66
	Daily Safety Verification Procedure	66

1 N1424A/B/C Resistivity Cell

General Information 12
Preparation for Use 13
Operation 20

Table 1-1 Keysight N1424A/B/C

Model number	Description																					
N1424A	Resistivity Cell (See Table 1-2 for the common accessories.)																					
N1424B	Resistivity Cell (See Table 1-2 for the common accessories.)																					
	<table border="1"> <thead> <tr> <th>Furnished accessories</th> <th>Keysight part number</th> <th>Quantity</th> </tr> </thead> <tbody> <tr> <td>Ø26 mm main electrode</td> <td>N1424-60083</td> <td>1</td> </tr> <tr> <td>Ø38 mm guard electrode</td> <td>N1424-24084</td> <td>1</td> </tr> <tr> <td>Spare screw</td> <td>0515-0907</td> <td>3</td> </tr> <tr> <td>Carrying case</td> <td>N1424-60191</td> <td>1</td> </tr> </tbody> </table>	Furnished accessories	Keysight part number	Quantity	Ø26 mm main electrode	N1424-60083	1	Ø38 mm guard electrode	N1424-24084	1	Spare screw	0515-0907	3	Carrying case	N1424-60191	1						
Furnished accessories	Keysight part number	Quantity																				
Ø26 mm main electrode	N1424-60083	1																				
Ø38 mm guard electrode	N1424-24084	1																				
Spare screw	0515-0907	3																				
Carrying case	N1424-60191	1																				
N1424C	Resistivity Cell (See Table 1-2 for the common accessories.)																					
	<table border="1"> <thead> <tr> <th>Furnished accessories</th> <th>Keysight part number</th> <th>Quantity</th> </tr> </thead> <tbody> <tr> <td>Ø26 mm main electrode</td> <td>N1424-60083</td> <td>1</td> </tr> <tr> <td>Ø38 mm guard electrode</td> <td>N1424-24084</td> <td>1</td> </tr> <tr> <td>Ø76 mm main electrode</td> <td>N1424-60085</td> <td>1</td> </tr> <tr> <td>Ø88 mm guard electrode</td> <td>N1424-24086</td> <td>1</td> </tr> <tr> <td>Spare screw</td> <td>0515-0907</td> <td>3</td> </tr> <tr> <td>Carrying case</td> <td>N1424-60191</td> <td>1</td> </tr> </tbody> </table>	Furnished accessories	Keysight part number	Quantity	Ø26 mm main electrode	N1424-60083	1	Ø38 mm guard electrode	N1424-24084	1	Ø76 mm main electrode	N1424-60085	1	Ø88 mm guard electrode	N1424-24086	1	Spare screw	0515-0907	3	Carrying case	N1424-60191	1
Furnished accessories	Keysight part number	Quantity																				
Ø26 mm main electrode	N1424-60083	1																				
Ø38 mm guard electrode	N1424-24084	1																				
Ø76 mm main electrode	N1424-60085	1																				
Ø88 mm guard electrode	N1424-24086	1																				
Spare screw	0515-0907	3																				
Carrying case	N1424-60191	1																				

General Information

The purpose of this chapter is to enable you to use your N1424A/B/C efficiently and confidently. This chapter contains both general and specific information. To use the N1424A/B/C to perform a specific function (without having to read the entire chapter), follow the directions in [“Using the N1424A/B/C.”](#)

Using the N1424A/B/C

The N1424A/B/C is an accessory for Keysight B2985B/B2987B Electrometer/High Resistance Meter. For connecting them, Keysight N1413A High Resistance Meter Fixture Adapter is required.

- To install the N1424A/B/C, turn to [“Preparation for Use” on page 13.](#)
- To use the N1424A/B/C, turn to [“Operation” on page 20.](#)

Product Description

The N1424A/B/C is used to measure the volume or surface resistance/resistivity of insulation materials. The N1424A/B/C has the following features.

- Electrode size selectable; Three different size electrodes to meet your DUT size requirements and to meet to electrode size requirements required by different standards.
- Can be used in $-30\text{ }^{\circ}\text{C}$ to $100\text{ }^{\circ}\text{C}$ ambient environments
- Arbitrary contact pressure can be applied on DUT
- Applicable test voltage 1000 V
- Applicable test current 10 mA

Operating and Safety Precautions

The voltage level (up to 1000 V) in this product warrants extreme care for operator safety. Service must be performed only by qualified personnel.

Preparation for Use

This section explains how to install the N1424A/B/C. The topics covered include initial inspection, ambient environmental considerations, connecting the product for use, and repackaging the product for shipping.

Initial Inspection

The product has been carefully inspected electrically and mechanically before being shipped from the factory. It should be in perfect physical condition, no scratches, dents or the like, and it should be in perfect electrical condition. Verify this by carefully performing an incoming inspection to check the product for signs of physical damage and missing contents. If any discrepancy is found, notify the carrier and Keysight Technologies. Your Keysight sales office will arrange for repair and replacement without waiting for the claim to be settled.

1. Inspect the shipping container for damage, and keep the shipping materials until the incoming inspection is completed.
2. Verify that the shipping container contains everything shown in [Figure 1-1](#) and listed in [Table 1-2](#). Also see [Table 1-1](#) for furnished accessories.
3. Inspect the exterior of the N1424A/B/C for any signs of damage.

Figure 1-1 Product Overview

N1424A/B/C

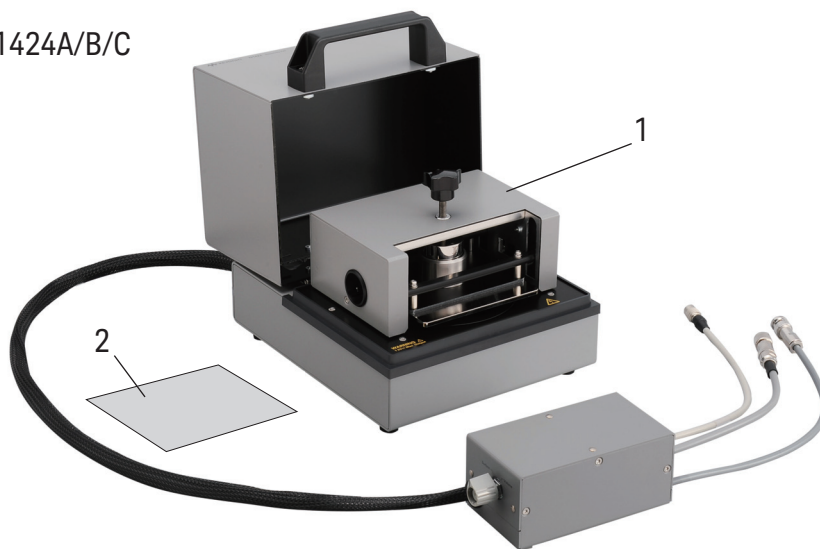

Table 1-2 Common Accessories for N1424A/B/C

Reference designator	Description	Keysight part number	Quantity
1	Upper electrode assembly	N1424-60071	1
2	Acrylic plate	N1424-25003	1
-	Ø50 mm main electrode	N1424-60081	1
-	Ø70 mm guard electrode	N1424-24082	1

Ambient Environmental Considerations

Operating and Storage

The N1424A/B/C must be operated within an ambient temperature range of $-30\text{ }^{\circ}\text{C}$ to $+100\text{ }^{\circ}\text{C}$ and relative humidity up to 70% RH at $40\text{ }^{\circ}\text{C}$ (non-condensing).

The N1424A/B/C may be stored within a temperature range of $-40\text{ }^{\circ}\text{C}$ to $+70\text{ }^{\circ}\text{C}$, and at a relative humidity up to 95% at $+40\text{ }^{\circ}\text{C}$ (non-condensing).



Using the N1424A/B/C in an Environmental Test Oven

The N1424A/B/C has the capability for high-temperature measurement in environmental testing up to +100 °C. This section provides information for using the N1424A/B/C in an environmental test chamber.

WARNING

Use gloves when handling the N1424A/B/C just after it comes out of a test oven or wait until it has cooled down enough to not cause burns.

Utiliser des gants lors de la manipulation du N1424A/B/C juste après sa sortie d'un four d'essai ou d'attendre jusqu'à ce qu'il ait suffisamment refroidi pour ne pas causer des brûlures.

NOTE

If the environmental test oven temperature exceeds 100 °C, the basic specifications will be invalid. You must pay close attention to temperature settings.

The Volume/Surface selector box must be located outside of the oven because it is not designed for operating at temperatures up to 100 °C. To locate the box outside of the oven, the Ø100 mm hole is required in the oven. [Figure 1-2](#) shows the measurement configuration when using the N1424A/B/C in an environmental test oven.

Figure 1-2 N1424A/B/C in an Environmental Test Oven

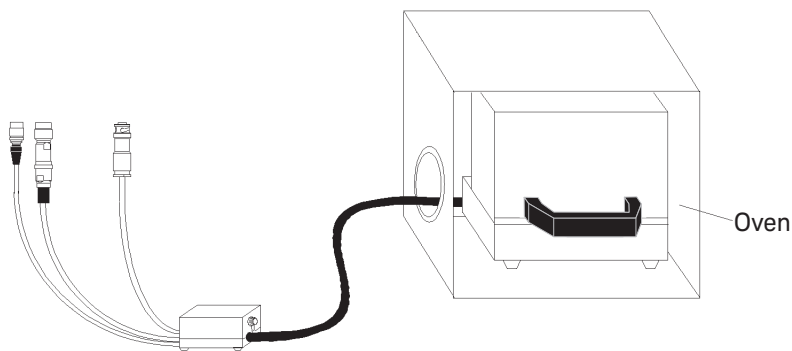

Exchanging the Electrode

WARNING

Do NOT touch the electrode and Voltage Source terminals while the High Voltage indicator is lit which shows the B2985B/B2987B's output is a high voltage of up to 1000 Vdc. You must operate after turning off the voltage source output and you have confirmed the high voltage indicator is turned off.

NE PAS toucher l'électrode et les bornes de la source de tension lorsque l'indicateur de haute tension est allumé, indiquant que la sortie de B2985B/B2987B est une tension élevée allant jusqu'à 1 000 V CC. Vous devez utiliser l'appareil après la mise hors tension de la sortie de source de tension et après avoir confirmé que l'indicateur de haute tension est éteint.

The N1424B/C has optional electrode in addition to the furnished $\varnothing 50$ mm electrode. You can exchange the electrode as required for your measurement. To exchange the electrode, do the following.

Figure 1-3 Exchanging the Electrode

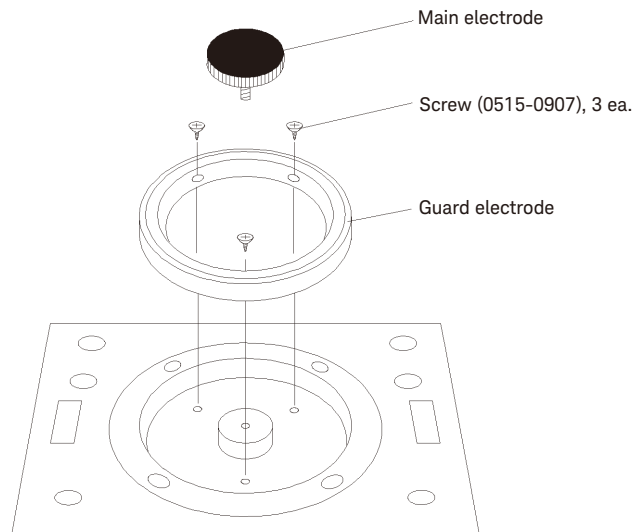



To Change Electrodes

1. If the N1424A/B/C is connected to the B2985B/B2987B, turn the B2985B/B2987B off.
2. Turn the Main electrode counterclockwise to loosen it, and then remove it.
3. Remove the three screws holding the Guard electrode in place.
4. Remove the Guard electrode.
5. Place the new Guard electrode so that the three holes are aligned with the three screw holes. See [Figure 1-3](#).
6. Insert and tighten the three screws.
7. Insert the new Main electrode and turn it clockwise to tighten it.
8. Confirm that the top of the Guard electrode sets higher than the top of the Main electrode.

CAUTION

You must handle the DUT contact of Guard electrode carefully because it is made from a soft material and is easily scratched.

You must keep the flatness between the Main electrode and the Guard electrode.

In case of being uneven between the Main electrode and the Guard electrode, the Main electrode may not connect with the DUT correctly.

⚠ Connecting the Product for Use

WARNING

Do NOT touch the electrode and Voltage Source terminals while the High Voltage indicator is lit which shows the B2985B/B2987B's output is a high voltage of up to 1000 Vdc. You must operate after turning off the voltage source output and you have confirmed the high voltage indicator is turned off.

NE PAS toucher l'électrode et les bornes de la source de tension lorsque l'indicateur de haute tension est allumé, indiquant que la sortie de B2985B/B2987B est une tension élevée allant jusqu'à 1 000 V CC. Vous devez utiliser l'appareil après la mise hors tension de la sortie de source de tension et après avoir confirmé que l'indicateur de haute tension est éteint.

Connect the N1413A to the B2985B/B2987B and connect the N1424A/B/C to the N1413A as shown in [Figure 1-4](#). You must connect BNC, triaxial, and interlock connectors. If the interlock connector is not connected, the B2985B/B2987B output voltage will be limited up to ± 21 V.

Figure 1-4 Connecting the Product

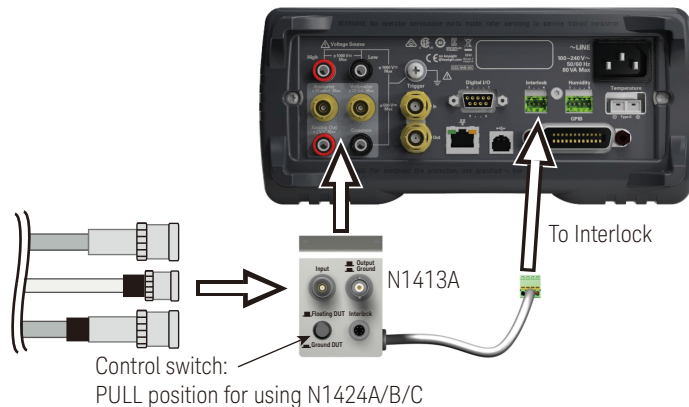

Set the control switch on the N1413A to the PULL position to use the N1424A/B/C. For more information, see *Keysight B2980B User's Guide*.

Repackaging the Product

If shipment to a Keysight Technologies service center is required, each product should be repackaged using the original factory packaging materials.

Alternatively, comparable packaging materials may be used. Wrap the product in heavy paper and pack in anti-static plastic packing material. Use sufficient shock absorbing material on all sides of the N1424A/B/C to provide a thick, firm cushion and to prevent movement. Seal the shipping container securely and mark it *FRAGILE*.

Operation

This section describes the features of the N1424A/B/C, and connections to the B2985B/B2987B and the DUT.



Product Features

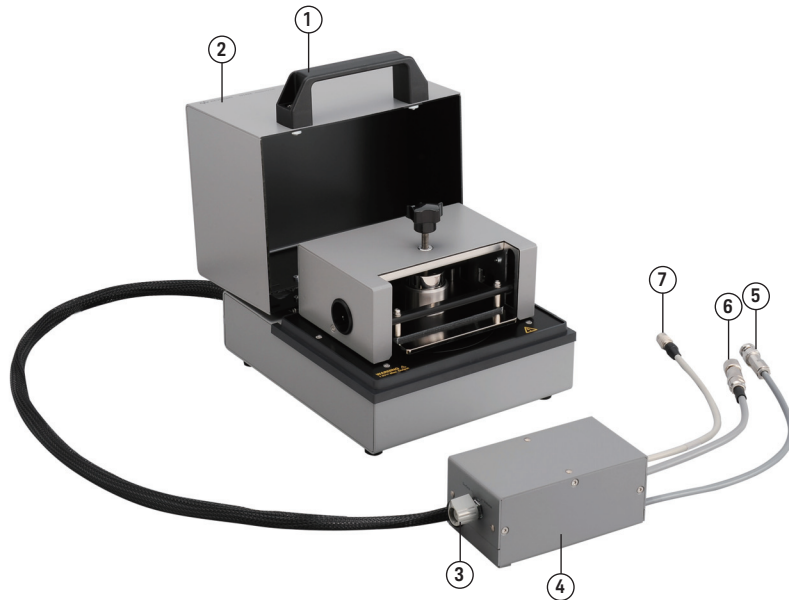

1. *Handle.*
2. *Top cover.* This shields against external electrical noise and enables the interlock function which limits the source voltage from the B2985B/B2987B. When the Top cover is opened, the B2985B/B2987B output voltage will be limited up to ± 21 V.
3. *Volume/Surface selector.* Used to select the volume or surface measurement mode.

When you change Volume and Surface mode, turn off the source voltage output of the B2985B/B2987B.
4. *Volume/Surface selector box.*

5. *BNC connector*. This connector provides the source voltage to the N1424A/B/C. This is a high voltage BNC connector and is not compatible with standard BNC connectors.
6. *Triaxial connector*. The measured signal is carried on the center conductor of this connector.
7. *Interlock connector*. This connector enables the interlock function which limits the source voltage from the B2985B/B2987B. When the Top cover is opened, the B2985B/B2987B output voltage will be limited up to ± 21 V.

Figure 1-5 Main/Guard/Upper Electrode

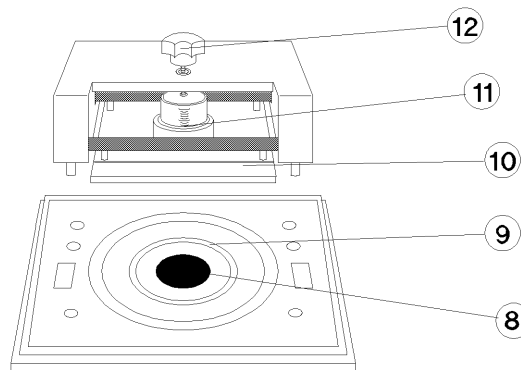

8. *Main electrode*. (covered with a conductive elastomer) The negative test voltage is applied from the Voltage Source terminal of the B2985B/B2987B.
9. *Guard electrode*. Provides the guard for Volume measurements. Applies the positive test voltage for surface measurements.
10. *Upper electrode*. Provides the guard for surface measurements. Applies the positive test voltage for volume measurements.
11. *Load scale*. This scale shows currently applied pressure in kilograms.
12. *Load knob*. To apply load for the DUT, turn this knob to clockwise.

NOTE

10, 11, and 12 are parts of *Upper electrode assembly* which is a replaceable part of the N1424A/B/C.

Applying Contact Pressure

The N1424A/B/C can apply contact pressure on the DUT of up to approximately 10 kg. The contact pressure Load Scale shows the approximately applied contact pressure in kilograms. To adjust the contact pressure, turn the load knob clockwise. [Figure 1-6](#) shows how to read the load scale.

Figure 1-6

Load Scale

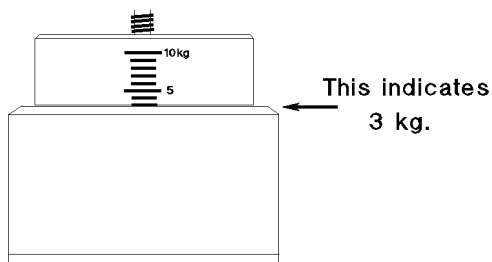

CAUTION

Do NOT adjust the contact pressure setting past the 10 kg mark or the N1424A/B/C may be mechanically damaged.

Making a Measurement

WARNING

Do NOT touch the electrode and Voltage Source terminals while the High Voltage indicator is lit which shows the B2985B/B2987B's output is a high voltage of up to 1000 Vdc. You must operate after turning off the voltage source output and you have confirmed the high voltage indicator is turned off.

NE PAS toucher l'électrode et les bornes de la source de tension lorsque l'indicateur de haute tension est allumé, indiquant que la sortie de B2985B/B2987B est une tension élevée allant jusqu'à 1 000 V CC. Vous devez utiliser l'appareil après la mise hors tension de la sortie de source de tension et après avoir confirmé que l'indicateur de haute tension est éteint.

Step-by-step instructions on how to make a measurement with the N1424A/B/C are as follows.

1. Connect the N1424A/B/C to the B2985B/B2987B as shown in [Figure 1-4](#).
2. Select either a surface or a volume measurement using the Volume/Surface selector.

Turn off the voltage output of the B2985B/B2987B when you change the Volume/Surface selector.
3. Place the DUT on the Main electrode, and then place the upper electrode on the DUT.
4. Turn the contact pressure load knob to adjust the electrode contact pressure on the DUT. See [“Applying Contact Pressure.”](#)
5. Close the Top cover of the N1424A/B/C.
6. Follow the measurement instructions described in *Keysight B2980B User's Guide* to perform the measurement.

Be sure to set the B2985B/B2987B's Voltage Source *Low Terminal State* to *FLOATING*.

For surface and volume measurements, different voltage polarities are applied to the DUT. When changing between surface and volume measurements, the B2985B/B2987B requires a settling time of at least one minute.

CAUTION

Do NOT short the upper and lower electrodes when Voltage Source is ON.

Removing the Upper Electrode

WARNING

Do NOT touch the electrode and Voltage Source terminals while the High Voltage indicator is lit which shows the B2985B/B2987B's output is a high voltage of up to 1000 Vdc. You must operate after turning off the voltage source output and you have confirmed the high voltage indicator is turned off.

NE PAS toucher l'électrode et les bornes de la source de tension lorsque l'indicateur de haute tension est allumé, indiquant que la sortie de B2985B/B2987B est une tension élevée allant jusqu'à 1 000 V CC. Vous devez utiliser l'appareil après la mise hors tension de la sortie de source de tension et après avoir confirmé que l'indicateur de haute tension est éteint.



To Remove Upper Electrode

1. If the N1424A/B/C is connected to the B2985B/B2987B, turn the B2985B/B2987B off.
2. Push the latch on both sides of the upper electrode assembly. See [Figure 1-7](#). The lock will then be released.
3. Lift the upper electrode assembly up and remove it.

Figure 1-7

Latch

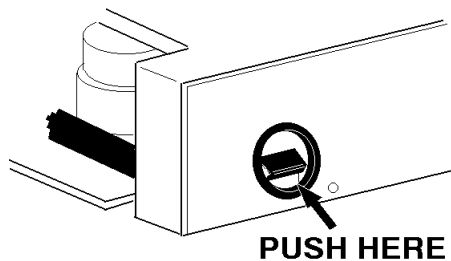

NOTE

The lock may not be released when you push the latch and a contact pressure load is still applied. If this happens turn the contact pressure load knob counterclockwise to decrease the applied pressure, until the lock is released.

Care of the Electrodes

WARNING

Do NOT touch the electrode and Voltage Source terminals while the High Voltage indicator is lit which shows the B2985B/B2987B's output is a high voltage of up to 1000 Vdc. You must operate after turning off the voltage source output and you have confirmed the high voltage indicator is turned off.

NE PAS toucher l'électrode et les bornes de la source de tension lorsque l'indicateur de haute tension est allumé, indiquant que la sortie de B2985B/B2987B est une tension élevée allant jusqu'à 1 000 V CC. Vous devez utiliser l'appareil après la mise hors tension de la sortie de source de tension et après avoir confirmé que l'indicateur de haute tension est éteint.

The electrodes should be kept clean to obtain complete contact with the DUT. To clean the electrodes (except for the conductive elastomer), wipe them with a dust free cloth that has been dipped in alcohol.

To avoid scratching the guard electrode when the N1424A/B/C is not in use, place the furnished acrylic plate between upper and guard electrodes, and apply a pre-load contact pressure to firmly hold the acrylic plate in place.

Checking Procedure

WARNING

Do NOT touch the electrode and Voltage Source terminals while the High Voltage indicator is lit which shows the B2985B/B2987B's output is a high voltage of up to 1000 Vdc. You must operate after turning off the voltage source output and you have confirmed the high voltage indicator is turned off.

NE PAS toucher l'électrode et les bornes de la source de tension lorsque l'indicateur de haute tension est allumé, indiquant que la sortie de B2985B/B2987B est une tension élevée allant jusqu'à 1 000 V CC. Vous devez utiliser l'appareil après la mise hors tension de la sortie de source de tension et après avoir confirmé que l'indicateur de haute tension est éteint.

The N1424A/B/C and the B2985B/B2987B is operated with high voltage up to 1000 V. These products are designed that the operator can measure safely. To keep the safe condition, you must execute following checking procedure periodically.



Daily Safety Verification Procedure

1. Connect the N1424A/B/C to the B2985B/B2987B as shown in [Figure 1-4](#).
2. Open measurement terminals and close the Top cover of the N1424A/B/C.
3. Set source voltage to +22 V.

Be sure to set the Voltage Source *Low Terminal State* to *FLOATING*.

4. Press Voltage Source On/Off switch of the B2985B/B2987B. And confirm that the On/Off switch turns red and the High Voltage indicator turns on.
5. Open the Top cover of the N1424A/B/C.
Confirm that the On/Off switch and the High Voltage indicator turn off immediately.
6. Close the Top cover again.

Confirm that the On/Off switch and the High Voltage indicator still turn off.

If you encountered any errors in checking procedure, contact your nearest Keysight office.

2 N1425A/B Low Noise Test Leads

General Information 28
Preparation for Use 29
Operation 32

Table 2-1 Keysight N1425A/B

Model number	Description
N1425A	Low Noise Test Leads, 1.5 m
N1425B	Low Noise Test Leads, 3 m

Table 2-2 Available Accessories for N1425A/B

Model number	Description
N1426A	Pin Probes
N1426B	Soldering Sockets
N1426C	Alligator Clips

General Information

The purpose of this chapter is to enable you to use your N1425A/B efficiently and confidently. This chapter contains both general and specific information. To use the N1425A/B to perform a specific function (without having to read the entire chapter), follow the directions in [“Using the N1425A/B.”](#)

Using the N1425A/B

The N1425A/B is an accessory for Keysight B2985B/B2987B Electrometer/ High Resistance Meter. For connecting them, Keysight N1413A High Resistance Meter Fixture Adapter is required.

- To install the N1425A/B, turn to [“Preparation for Use” on page 29.](#)
- To use the N1425A/B, turn to [“Operation” on page 32.](#)

Product Description

The N1425A/B is used to measure the resistance of insulation materials. The N1425A/B has the following features.

- Reducing electrical noise effects by using shielded cable
- High-voltage safety designed using an interlock circuit
- Applicable test voltage 1000 V
- Applicable test current 0.5 mA

Operating and Safety Precautions

The voltage level (up to 1000 V) in this product warrants extreme care for operator safety. Service must be performed only by qualified personnel.

Preparation for Use

This section explains how to install the N1425A/B. The topics covered include initial inspection, ambient environmental considerations, connecting the product for use, and repackaging the product for shipping.

Figure 2-1 N1425A/B and Available Accessories

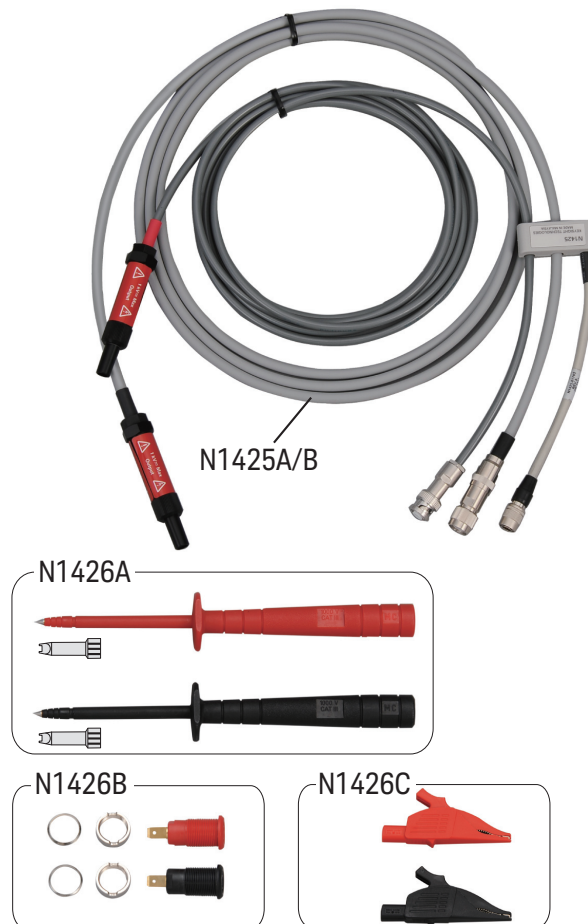

Initial Inspection

The product has been carefully inspected electrically and mechanically before being shipped from the factory. It should be in perfect physical condition, no scratches, dents or the like, and it should be in perfect electrical condition. Verify this by carefully performing an incoming inspection to check the product for signs of physical damage and missing contents. If any discrepancy is found, notify the carrier and Keysight Technologies. Your Keysight sales office will arrange for repair and replacement without waiting for the claim to be settled.

1. Inspect the shipping container for damage, and keep the shipping materials until the incoming inspection is completed.
2. Verify that the shipping container contains everything shown in [Figure 2-1](#). Also see [Table 2-2](#) for available accessories.
3. Inspect the exterior of the N1425A/B for any signs of damage.

Ambient Environmental Considerations

Operating and Storage

The N1425A/B must be operated within an ambient temperature range of 0 °C to +55 °C and relative humidity up to 70% RH at 40 °C (non-condensing).

The N1425A/B may be stored within a temperature range of -40 °C to +70 °C, and at a relative humidity up to 95% at +40 °C (non-condensing).



Connecting the Product for Use

WARNING

Do NOT touch the electrode and Voltage Source terminals while the High Voltage indicator is lit which shows the B2985B/B2987B's output is a high voltage of up to 1000 Vdc. You must operate after turning off the voltage source output and you have confirmed the high voltage indicator is turned off.

NE PAS toucher l'électrode et les bornes de la source de tension lorsque l'indicateur de haute tension est allumé, indiquant que la sortie de B2985B/B2987B est une tension élevée allant jusqu'à 1 000 V CC. Vous devez utiliser l'appareil après la mise hors tension de la sortie de source de tension et après avoir confirmé que l'indicateur de haute tension est éteint.

Connect the N1413A to the B2985B/B2987B and connect the N1425A/B to the N1413A as shown in [Figure 2-2](#). You must connect BNC, triaxial, and interlock connectors. If the interlock connector is not connected, the B2985B/B2987B output voltage will be limited up to ± 21 V.

Figure 2-2 Connecting the Product

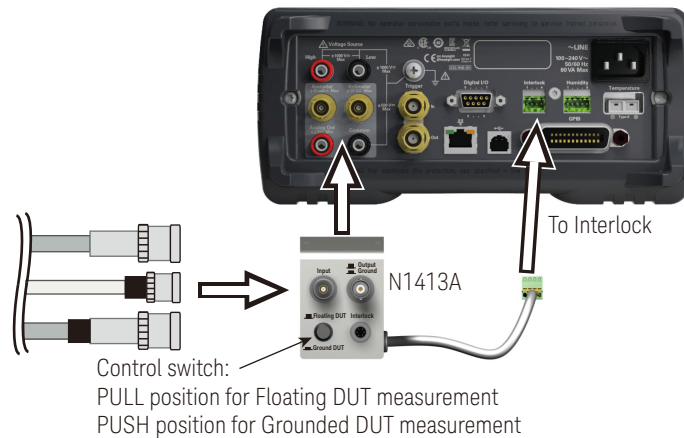

Set the control switch on the N1413A properly depending on the measurement configuration. For more information, see *Keysight B2980B User's Guide*.

Repackaging the Product

If shipment to a Keysight Technologies service center is required, each product should be repackaged using the original factory packaging materials.

Alternatively, comparable packaging materials may be used. Wrap the product in heavy paper and pack in anti-static plastic packing material. Use sufficient shock absorbing material on all sides of the N1425A/B to provide a thick, firm cushion and to prevent movement. Seal the shipping container securely and mark it *FRAGILE*.

Operation

This section describes the features of the N1425A/B, and connections to the B2985B/B2987B and the DUT.



Product Features

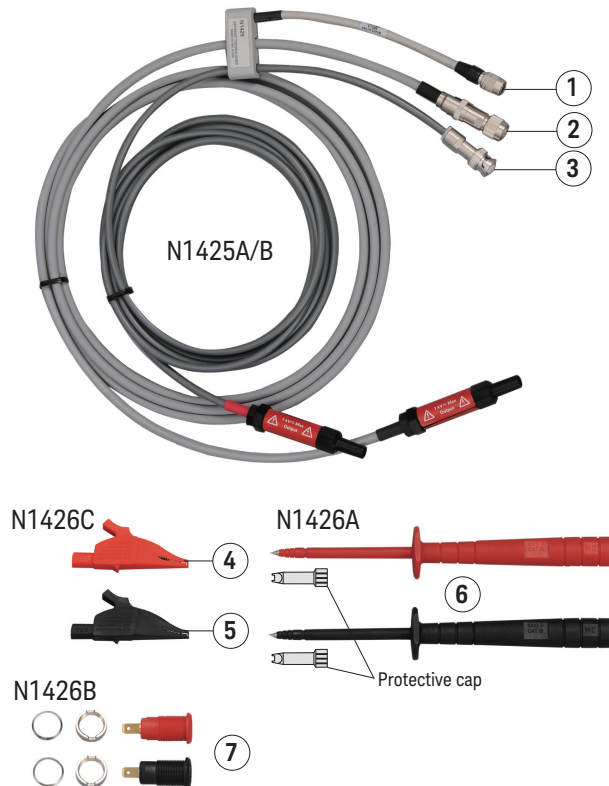

1. *Interlock connector.* This connector enables the interlock function which limits the source voltage from the B2985B/B2987B. When the interlock terminal of the B2985B/B2987B is opened, the source voltage will be limited up to ± 21 V.
2. *Triaxial connector.* The measured signal is carried on the center conductor of this connector.

3. *BNC connector*. This connector provides the source voltage to the N1425A/B. This is a high voltage BNC connector and is not compatible with standard BNC connectors.
4. *Alligator clip (red, part of N1426C)*. When making a floating DUT configuration measurement, the Red test clip provides a source voltage of up to 1000 V. In the grounded DUT measurement configuration, the Red test clip is connected to ground.
5. *Alligator clip (black, part of N1426C)*. When making a floating DUT configuration measurement, the Black test clip becomes the measurement signal path. In the grounded DUT measurement configuration, the Black test clip provides a source voltage of up to 1000 V.
6. *Pin probes (red and black, N1426A)*. The probes enable to measure flat or small DUTs such as PC boards and IC sockets. It can be attached to the ends of the low noise test leads in place of the Alligator Clips. The Protective Cap is useful for probing IC pin. Using the cap can avoid making contact with adjacent IC pins.
7. *Soldering sockets (red and black, N1426B)*. The sockets help make simple custom-made test leads.

Making a Measurement

WARNING

Do NOT touch the electrode and Voltage Source terminals while the High Voltage indicator is lit which shows the B2985B/B2987B's output is a high voltage of up to 1000 Vdc. You must operate after turning off the voltage source output and you have confirmed the high voltage indicator is turned off.

NE PAS toucher l'électrode et les bornes de la source de tension lorsque l'indicateur de haute tension est allumé, indiquant que la sortie de B2985B/B2987B est une tension élevée allant jusqu'à 1 000 V CC. Vous devez utiliser l'appareil après la mise hors tension de la sortie de source de tension et après avoir confirmé que l'indicateur de haute tension est éteint.

Step-by-step instructions on how to make a measurement with the N1425A/B are as follows.

1. Connect the N1425A/B to the B2985B/B2987B as shown in [Figure 2-2](#).
2. Connect the DUT.
3. Follow the measurement instructions described in *Keysight B2980B User's Guide* to perform the measurement.

Be sure to set the B2985B/B2987B's Voltage Source *Low Terminal State* to *FLOATING*.

Pin Probes (N1426A)

The Pin Probes (N1426A) enables to measure flat or small DUTs such as PC boards and IC sockets.

WARNING

You must handle between guard collar and socket (see figure below) to prevent an electrical shock when Voltage Source On/Off switch of the B2985B/B2987B is ON.

Vous devez être capable de manipuler l'entretoise épaulée de protection et la prise (voir l'illustration ci-dessous), afin d'éviter tout risque de décharge électrique lorsque le commutateur de Marche/Arrêt de B2985B/B2987B est en position Marche.



NOTE

The protective cap avoids making contact with adjacent pins. When measuring IC pins, attach the protective cap to the tip of the probe.

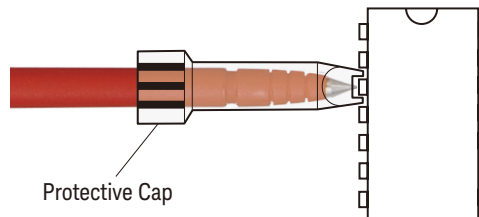

Soldering Sockets (N1426B)

The Soldering Sockets (N1426B) helps make simple custom-made test leads.

WARNING

Keysight Technologies shall NOT LIABLE for any damages or dangers to the operator incurred on use of a customized product except for the N1425A/B itself.

Test fixtures designed by users are exposed to voltages up to 1 kV. An operator may receive an electrical shock if he/she makes contact with test fixture components. Design all components/test fixtures so that an operator can use the fixture safely, without being exposed to electrical shock hazard.

For example:

- Insulate all connections, solder joints, bare conductors.
 - Design the fixture so that an operator cannot touch the measurement terminals when making the measurement.
 - Provide warning labels to warn the operator of the high-voltage danger, and to avoid touching any connections, terminals, or DUT when the measurement is in process or when the high voltage is turned on.
-

WARNING

Keysight Technologies NE doit PAS ÊTRE TENU POUR RESPONSABLE des dommages et dangers engagés par l'utilisation d'un produit personnalisé, à l'exception du N1425A/B lui-même.

Les montages d'essai conçus par les utilisateurs s'exposent à des tensions allant jusqu'à 1 kV. Un opérateur peut recevoir une décharge électrique si il/elle entre en contact avec les éléments du montage d'essai. Concevez tous les composants/montages d'essai de manière à ce qu'ils puissent être utilisés par l'opérateur en toute sécurité, sans que ce dernier ne soit exposé à un risque de décharge électrique.

Par exemple :

- Isolez toutes les connexions, les joints de soudure, les conducteurs nus.
 - Concevez le montage de manière à ce qu'un opérateur ne puisse pas toucher les bornes de mesure lors de la prise de mesures.
 - Fournissez des étiquettes d'avertissement afin d'indiquer à l'opérateur le danger de haute tension, et afin d'éviter tout contact avec les connexions, les bornes, ou le DUT lorsque la mesure est en cours ou lorsque l'alimentation haute tension est en marche.
-

Checking Procedure

WARNING

Do NOT touch the electrode and Voltage Source terminals while the High Voltage indicator is lit which shows the B2985B/B2987B's output is a high voltage of up to 1000 Vdc. You must operate after turning off the voltage source output and you have confirmed the high voltage indicator is turned off.

NE PAS toucher l'électrode et les bornes de la source de tension lorsque l'indicateur de haute tension est allumé, indiquant que la sortie de B2985B/B2987B est une tension élevée allant jusqu'à 1 000 V CC. Vous devez utiliser l'appareil après la mise hors tension de la sortie de source de tension et après avoir confirmé que l'indicateur de haute tension est éteint.

The N1425A/B and the B2985B/B2987B is operated with high voltage up to 1000 V. These products are designed that the operator can measure safely. To keep the safe condition, you must execute following checking procedure periodically.



Daily Safety Verification Procedure

1. Connect the N1425A/B to the B2985B/B2987B as shown in [Figure 2-2](#).
2. Leave the test clips (or probes) open and separated from each other.
3. Set source voltage to +22 V.

Be sure to set the Voltage Source *Low Terminal State* to *FLOATING*.

4. Press Voltage Source On/Off switch of the B2985B/B2987B.

Confirm that the On/Off switch turns red and the High Voltage indicator turns on.

5. Disconnect the interlock connector of the N1425A/B from the N1413A.

Confirm that the On/Off switch and the High Voltage indicator turn off immediately.

6. Reconnect the interlock connector to the N1413A.

Confirm that the On/Off switch and the High Voltage indicator still turn off.

If you encountered any errors in checking procedure, contact your nearest Keysight office.

3 N1427A/B Low Noise Test Cables

General Information 40
Preparation for Use 41
Operation 48

Table 3-1

Keysight N1427A/B

Model number	Description		
N1427A	Low Noise Test Cables, 1.5 m		
	Furnished accessories	Keysight part number	Quantity
	BNC female connector	1250-2317	1
	Triaxial female connector	1250-2228	1
N1427B	Low Noise Test Cables, 3 m		
	Furnished accessories	Keysight part number	Quantity
	BNC female connector	1250-2317	1
	Triaxial female connector	1250-2228	1

General Information

The purpose of this chapter is to enable you to use your N1427A/B efficiently and confidently. This chapter contains both general and specific information. To use the N1427A/B to perform a specific function (without having to read the entire chapter), follow the directions in [“Using the N1427A/B.”](#)

Using the N1427A/B

The N1427A/B is an accessory for Keysight B2985B/B2987B Electrometer/ High Resistance Meter. For connecting them, Keysight N1413A High Resistance Meter Fixture Adapter is required.

- To install the N1427A/B, turn to [“Preparation for Use” on page 41.](#)
- To use the N1427A/B, turn to [“Operation” on page 48.](#)

Product Description

The N1427A/B is used to measure insulation resistance. The N1427A/B has the following features.

- Prepared exclusive connector for the B2985B/B2987B. This allows easy to make your original test fixture for the B2985B/B2987B.
- High-voltage safety designed using an interlock circuit
- Applicable test voltage 1000 V
- Applicable test current 10 mA

Operating and Safety Precautions

The voltage level (up to 1000 V) in this product warrants extreme care for operator safety. Service must be performed only by qualified personnel.

Preparation for Use

This section explains how to install the N1427A/B. The topics covered include initial inspection, ambient environmental considerations, connecting the product for use, and repackaging the product for shipping.

Figure 3-1 Product Overview



Initial Inspection

The product has been carefully inspected electrically and mechanically before being shipped from the factory. It should be in perfect physical condition, no scratches, dents or the like, and it should be in perfect electrical condition. Verify this by carefully performing an incoming inspection to check the product for signs of physical damage and missing contents. If any discrepancy is found, notify the carrier and Keysight Technologies. Your Keysight sales office will arrange for repair and replacement without waiting for the claim to be settled.

1. Inspect the shipping container for damage, and keep the shipping materials until the incoming inspection is completed.
2. Verify that the shipping container contains everything shown in [Figure 3-1](#) and [Table 3-1](#).
3. Inspect the exterior of the N1427A/B for any signs of damage.

Ambient Environmental Considerations

Operating and Storage

The N1427A/B must be operated within an ambient temperature range of 0 °C to +55 °C and relative humidity up to 70% RH at 40 °C (non-condensing).

The N1427A/B may be stored within a temperature range of –40 °C to +70 °C, and at a relative humidity up to 95% at +40 °C (non-condensing).



Making a Custom Test Fixture

NOTE

When you make a custom test fixture using the N1427A/B, you must observe the usage guidelines described in this section.

The N1427A/B is the accessory for making a custom test fixture for the B2985B/B2987B. Prepare chassis, coaxial cable, wire, socket and so on for making your original test fixture. And assemble it.

For the N1427A/B itself, see “[Product Features](#)” on page 48.

For connecting the triaxial connector and the BNC connector, see [Figure 3-2](#).

For connecting the interlock cable, see “[Interlock Circuit](#)” on page 43.

For an example connection, see “[Example Configuration of Custom Test Fixture](#)” on page 45.

Figure 3-2

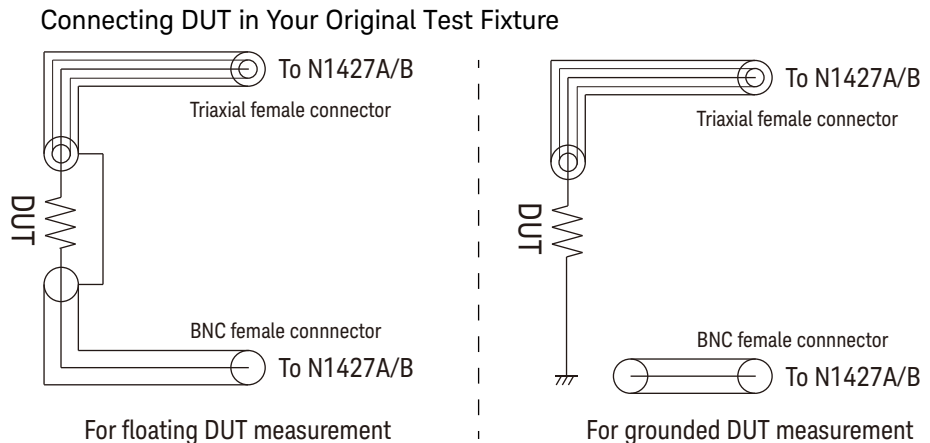

A triaxial connector is used for the measured signal path. The triaxial connector's center conductor carries the signal. The inner shield is a Guard, and the outer shield is the ground. Using a guard circuit reduces leakage current and external noise to the center conductor. The Guard must be extend as close as possible to the DUT contact, but not connected. The BNC connector's shield is the ground.

For the floating DUT measurement configuration, the source voltage up to 1000 V is applied to the BNC connector's center conductor.

For the grounded DUT measurement configuration, the source voltage up to 1000 V is applied to the triaxial connector's center conductor and the inner shield (Guard). The BNC connector's center conductor is the ground.



Interlock Circuit

For operator safety, the B2985B/B2987B provides the interlock function which limits the output voltage. If the interlock terminal of the B2985B/B2987B is opened, the output voltage is limited up to ± 21 V. The interlock circuit must be installed in your custom test fixture and connected to the interlock terminal if you need the voltage over the limit.

For making the interlock circuit, prepare the interlock cable of the N1427A/B, mechanical switch and wire. And install it as shown in [Figure 3-4](#). This example uses two switches. They must be fixed on the test fixture so that each switch can be the break condition by opening the test fixture cover and each switch can be the make condition by closing the cover. And they must be connected in series between the Interlock (1, Brown) and the Ground (6) of the interlock cable. See [Figure 3-3](#).

The wires 2 to 5 are not used. They can be connected to the chassis ground or opened. The end of unconnected wire should be covered with insulation material.

NOTE

The interlock circuit should have two or more switches. This is effective to avoid unexpectedly applying source voltage due to trouble with the mechanical switch.

Preparation for Use
Interlock Circuit

Figure 3-3

Wire Side of Interlock Cable

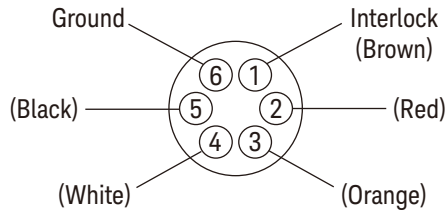
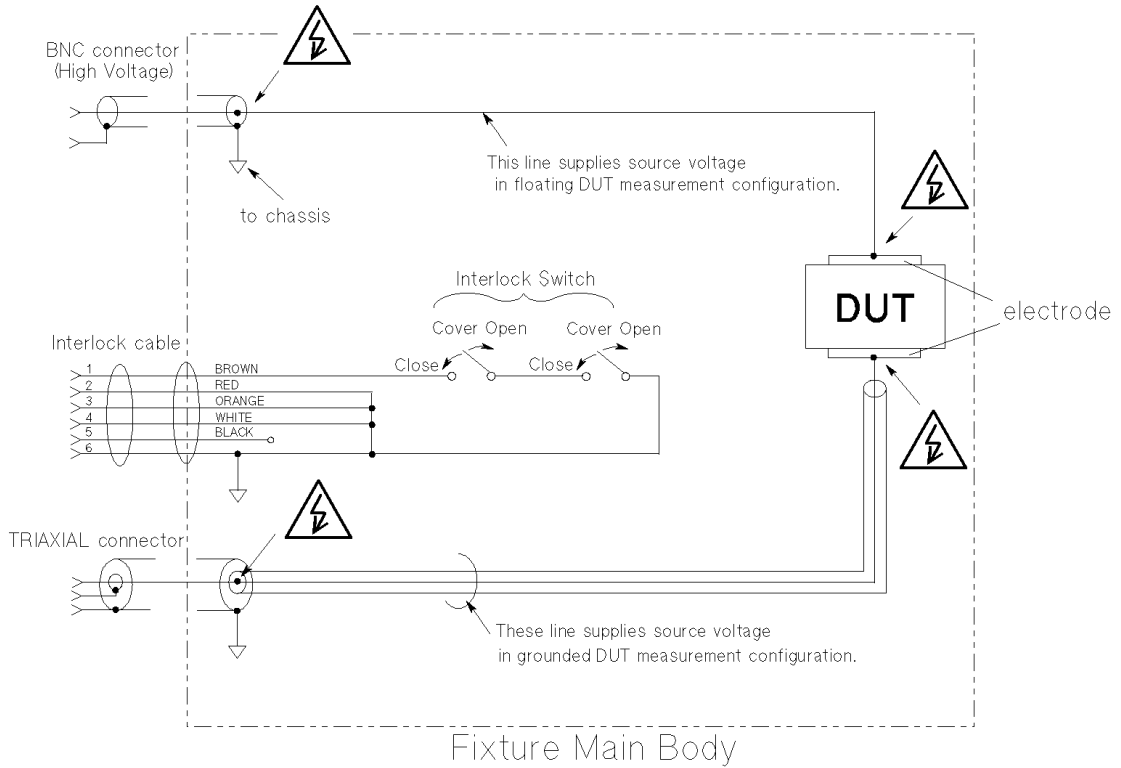



Figure 3-4

Example Configuration of Custom Test Fixture



 indicates dangerous point for high voltage (up to 1000 V).



Example Configuration of Custom Test Fixture

WARNING

Keysight Technologies shall NOT LIABLE for any damages or dangers to the operator incurred on use of a customized product except for the N1427A/B itself.

Keysight Technologies NE doit PAS ÊTRE TENU POUR RESPONSABLE des dommages et dangers engagés par l'utilisation d'un produit personnalisé, à l'exception du N1427A/B lui-même.

WARNING

You must design the test fixture so the operator cannot touch the points which are indicated or the dangerous voltage symbol in **Figure 3-4**, to avoid electrical hazards to the operator. Especially, around the electrodes should be protected with a cover which is interlocked with source voltage output.

Vous devez concevoir le montage d'essai de manière à ce que l'opérateur ne puisse pas toucher les points indiqués par le symbole de tension dangereuse dans l'illustration (**Figure 3-4**), afin d'éviter tout danger électrique pour l'opérateur. L'espace autour des électrodes doit tout particulièrement être protégé par un couvercle qui est interverrouillé avec une sortie de tension d'alimentation.

Figure 3-4 shows an example of test fixture configuration. This example shows the test fixture for measuring insulation resistance. The test fixture must have a cover and an interlock circuit to avoid electrical shock. See **“Interlock Circuit” on page 43**.

Voltage of up to 1000 V is applied to the triaxial connector's center conductor and inner shield and the BNC connector's center conductor. Use cable and wire which can withstand a voltage over 1000 V. Also see **Figure 3-2**.

Connecting the Product for Use

WARNING

Do NOT touch the electrode and Voltage Source terminals while the High Voltage indicator is lit which shows the B2985B/B2987B's output is a high voltage of up to 1000 Vdc. You must operate after turning off the voltage source output and you have confirmed the high voltage indicator is turned off.

NE PAS toucher l'électrode et les bornes de la source de tension lorsque l'indicateur de haute tension est allumé, indiquant que la sortie de B2985B/B2987B est une tension élevée allant jusqu'à 1 000 V CC. Vous devez utiliser l'appareil après la mise hors tension de la sortie de source de tension et après avoir confirmé que l'indicateur de haute tension est éteint.

Connect the N1413A to the B2985B/B2987B and connect the N1427A/B to the N1413A as shown in [Figure 3-5](#). You must connect BNC, triaxial, and interlock connectors. If the interlock connector is not connected, the B2985B/B2987B output voltage will be limited up to ± 21 V.

Figure 3-5 Connecting the Product

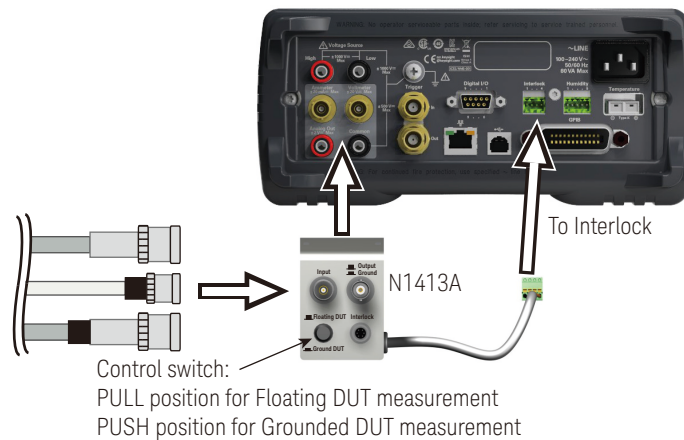

Set the control switch on the N1413A properly depending on the measurement configuration. For more information, see *Keysight B2980B User's Guide*.

Repackaging the Product

If shipment to a Keysight Technologies service center is required, each product should be repackaged using the original factory packaging materials.

Alternatively, comparable packaging materials may be used. Wrap the product in heavy paper and pack in anti-static plastic packing material. Use sufficient shock absorbing material on all sides of the N1427A/B to provide a thick, firm cushion and to prevent movement. Seal the shipping container securely and mark it *FRAGILE*.

Operation

This section describes the features of the N1427A/B, and connections to the B2985B/B2987B and the DUT.



Product Features

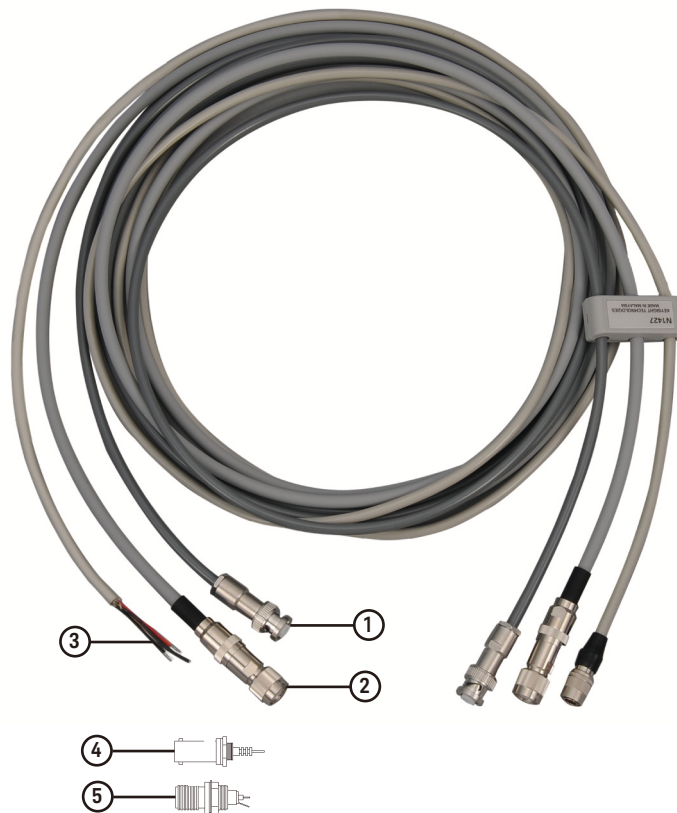

1. *BNC cable.* This connector provides the source voltage to the N1427A/B. This is a high voltage BNC connector and is not compatible with standard BNC connectors.
2. *Triaxial cable.* The measured signal is carried on the center conductor of this connector.

3. *Interlock cable.* This cable enables the interlock function which limits the source voltage from the B2985B/B2987B. When the interlock terminal of the B2985B/B2987B is opened, the source voltage will be limited up to ± 21 V. Wire side of this cable must be connected to an interlock circuit on a custom test fixture.
4. *BNC female connector.* This connector should be mounted on a custom test fixture and used to connect the BNC cable of the N1427A/B. Soldering side of this connector must be connected to DUT by using extension cable, wire, socket and so on.
5. *Triaxial female connector.* This connector should be mounted on a custom test fixture and used to connect the Triaxial cable of the N1427A/B. Soldering side of this connector must be connected to DUT by using extension cable, wire, socket and so on.

Making a Measurement

WARNING

Do NOT touch the electrode and Voltage Source terminals while the High Voltage indicator is lit which shows the B2985B/B2987B's output is a high voltage of up to 1000 Vdc. You must operate after turning off the voltage source output and you have confirmed the high voltage indicator is turned off.

NE PAS toucher l'électrode et les bornes de la source de tension lorsque l'indicateur de haute tension est allumé, indiquant que la sortie de B2985B/B2987B est une tension élevée allant jusqu'à 1 000 V CC. Vous devez utiliser l'appareil après la mise hors tension de la sortie de source de tension et après avoir confirmé que l'indicateur de haute tension est éteint.

Step-by-step instructions on how to make a measurement with the N1427A/B are as follows.

1. Connect the N1427A/B to the B2985B/B2987B as shown in [Figure 3-5](#).
2. Connect the DUT.
3. Close the cover of the test fixture.
4. Follow the measurement instructions described in *Keysight B2980B User's Guide* to perform the measurement.

Be sure to set the B2985B/B2987B's Voltage Source *Low Terminal State* to *FLOATING*.

Checking Procedure

The N1427A/B and the B2985B/B2987B is operated with high voltage up to 1000 V. These products are designed that the operator can measure safely. To keep the safe condition, you must execute following checking procedure periodically.

This procedure assumes your custom test fixture has a cover interlocking source voltage output of the B2985B/B2987B.



Daily Safety Verification Procedure

1. Connect the N1427A/B to the B2985B/B2987B as shown in [Figure 3-5](#).
2. Open measurement terminals and close the cover of the test fixture.
3. Set source voltage to +22 V.

Be sure to set the Voltage Source *Low Terminal State* to *FLOATING*.

4. Press Voltage Source On/Off switch of the B2985B/B2987B.

Confirm that the On/Off switch turns red and the High Voltage indicator turns on.

5. Open the cover of the test fixture.

Confirm that the On/Off switch and the High Voltage indicator turn off immediately.

6. Close the cover again.

Confirm that the On/Off switch and the High Voltage indicator still turn off.

If you encountered any errors in checking procedure, contact your nearest Keysight office.

WARNING

Do NOT touch the electrode and Voltage Source terminals while the High Voltage indicator is lit which shows the B2985B/B2987B's output is a high voltage of up to 1000 Vdc. You must operate after turning off the voltage source output and you have confirmed the high voltage indicator is turned off.

NE PAS toucher l'électrode et les bornes de la source de tension lorsque l'indicateur de haute tension est allumé, indiquant que la sortie de B2985B/B2987B est une tension élevée allant jusqu'à 1 000 V CC. Vous devez utiliser l'appareil après la mise hors tension de la sortie de source de tension et après avoir confirmé que l'indicateur de haute tension est éteint.

Operation
Checking Procedure

4 N1428A Component Test Fixture

General Information 54
Preparation for Use 55
Operation 61

Table 4-1

Keysight N1428A

Model number	Description		
N1428A	Component Test Fixture		
	Furnished accessories	Keysight part number	Quantity
	Surface Mount Device (SMD) module	N1428-60101	1
	Flat table	N1428-60004	1
	Miniature banana-plug cable	N1428-61621	2
	Short bar (Note 1)	N1428-00651	1
	100 k Ω output resistor	N1428-61001	1
	1 M Ω output resistor	N1428-61002	1
	10 M Ω output resistor	N1428-61003	1
	100 M Ω output resistor	N1428-61004	1
	Alligator clip	8710-1984	2
	Carrying case	N1428-60021	1

Note 1 Short bar has been connected in the output resistor cover before being shipped from the factory. See [Figure 4-4](#).

General Information

The purpose of this chapter is to enable you to use your N1428A efficiently and confidently. This chapter contains both general and specific information. To use the N1428A to perform a specific function (without having to read the entire chapter), follow the directions in [“Using the N1428A.”](#)

Using the N1428A

The N1428A is an accessory for Keysight B2985B/B2987B Electrometer/High Resistance Meter. For connecting them, Keysight N1413A High Resistance Meter Fixture Adapter is required.

- To install the N1428A, turn to [“Preparation for Use” on page 55.](#)
- To use the N1428A, turn to [“Operation” on page 61.](#)

Product Description

The N1428A is used to measure chip, lead, or other types of components. The N1428A has the following features.

- Reduce electrical noise effects by using a shielded case
- Chip and lead components can be measured in a component socket
- High-voltage safety designed using an interlock circuit
- Applicable test voltage 1000 V
- Applicable test current 10 mA

Operating and Safety Precautions

The voltage level (up to 1000 V) in this product warrants extreme care for operator safety. Service must be performed only by qualified personnel.

Preparation for Use

This section explains how to install the N1428A. The topics covered include initial inspection, ambient environmental considerations, connecting the product for use, and repackaging the product for shipping.

Initial Inspection

The product has been carefully inspected electrically and mechanically before being shipped from the factory. It should be in perfect physical condition, no scratches, dents or the like, and it should be in perfect electrical condition. Verify this by carefully performing an incoming inspection to check the product for signs of physical damage and missing contents. If any discrepancy is found, notify the carrier and Keysight Technologies. Your Keysight sales office will arrange for repair and replacement without waiting for the claim to be settled.

1. Inspect the shipping container for damage, and keep the shipping materials until the incoming inspection is completed.
2. Verify that the shipping container contains everything shown in [Figure 4-1](#) and listed in [Table 4-2](#). See [Table 4-1](#) for all furnished accessories.
3. Inspect the exterior of the N1428A for any signs of damage.

Ambient Environmental Considerations

Operating and Storage

The N1428A must be operated within an ambient temperature range of 0 °C to +55 °C and relative humidity up to 70% RH at 40 °C (non-condensing).

The N1428A may be stored within a temperature range of –40 °C to +70 °C, and at a relative humidity up to 95% at +40 °C (non-condensing).

Preparation for Use
Ambient Environmental Considerations

Figure 4-1 Product Overview

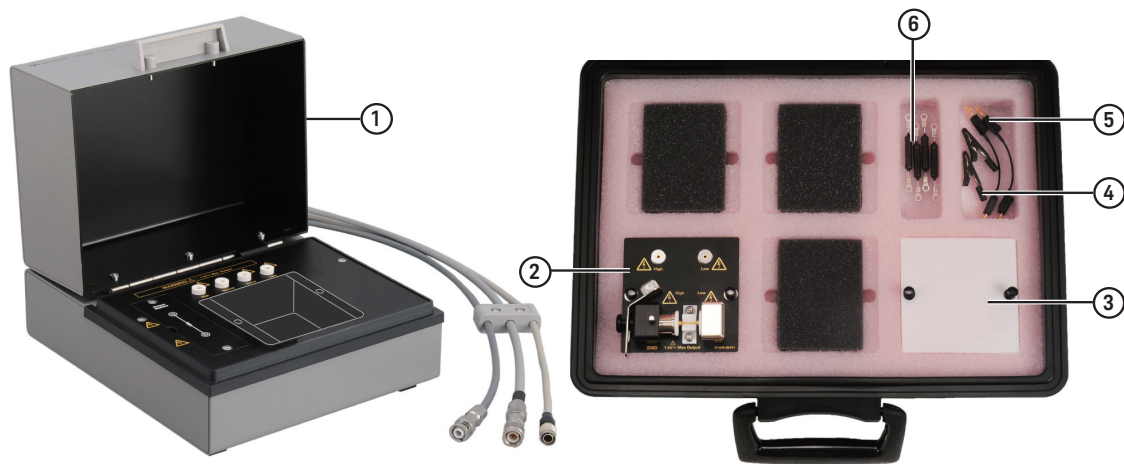

Table 4-2 Contents

Reference designator	Description	Keysight part number	Quantity
1	Component test fixture	-	1
2	Surface Mount Device (SMD) module	N1428-60101	1
3	Flat table	N1428-60004	1
4	Alligator clip	8710-1984	2
5	Miniature banana-plug cable	N1428-61621	2
6	100 k Ω output resistor	N1428-61001	1
	1 M Ω output resistor	N1428-61002	1
	10 M Ω output resistor	N1428-61003	1
	100 M Ω output resistor	N1428-61004	1

⚠ Connecting the Product for Use

WARNING

Do NOT touch the electrode and Voltage Source terminals while the High Voltage indicator is lit which shows the B2985B/B2987B's output is a high voltage of up to 1000 Vdc. You must operate after turning off the voltage source output and you have confirmed the high voltage indicator is turned off.

NE PAS toucher l'électrode et les bornes de la source de tension lorsque l'indicateur de haute tension est allumé, indiquant que la sortie de B2985B/B2987B est une tension élevée allant jusqu'à 1 000 V CC. Vous devez utiliser l'appareil après la mise hors tension de la sortie de source de tension et après avoir confirmé que l'indicateur de haute tension est éteint.

Connect the N1413A to the B2985B/B2987B and connect the N1428A to the N1413A as shown in Figure 4-2. You must connect BNC, triaxial, and interlock connectors. If the interlock connector is not connected, the B2985B/B2987B output voltage will be limited up to ± 21 V.

Figure 4-2 Connecting the Product

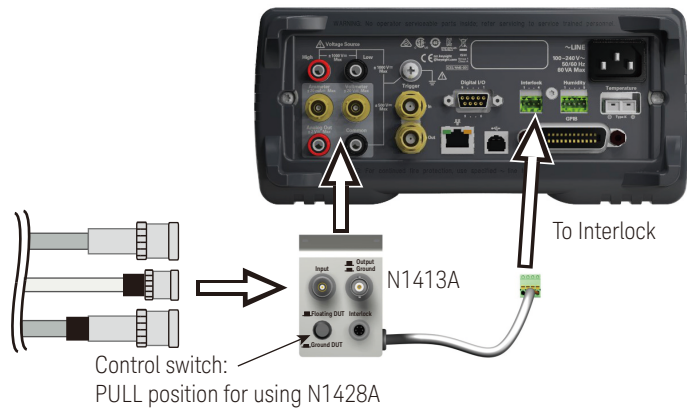

Set the control switch on the N1413A to the PULL position to use the N1428A. For more information, see *Keysight B2980B User's Guide*.

Exchanging the SMD Module or Flat Table

WARNING

Do NOT touch the electrode and Voltage Source terminals while the High Voltage indicator is lit which shows the B2985B/B2987B's output is a high voltage of up to 1000 Vdc. You must operate after turning off the voltage source output and you have confirmed the high voltage indicator is turned off.

NE PAS toucher l'électrode et les bornes de la source de tension lorsque l'indicateur de haute tension est allumé, indiquant que la sortie de B2985B/B2987B est une tension élevée allant jusqu'à 1 000 V CC. Vous devez utiliser l'appareil après la mise hors tension de la sortie de source de tension et après avoir confirmé que l'indicateur de haute tension est éteint.

The following procedure describes how to set and remove the SMD module or the flat table.

Setting Procedure

1. Pull the clamps up.
2. Insert the SMD module or the flat table.
3. Push the clamps down.
4. Connect the miniature banana cables.

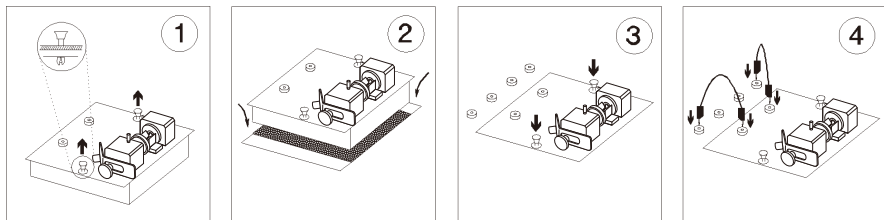

Removal Procedure

1. Disconnect the miniature banana cables.
2. Pull the clamps up.
3. Remove the SMD module or the flat table.

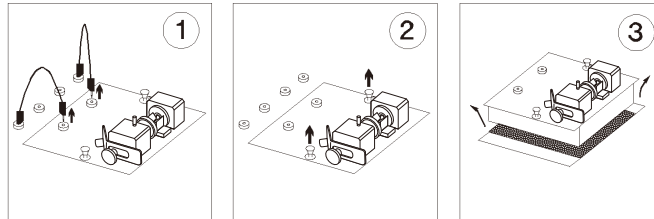

Setup Image

The following figure shows the image of using the SMD module or the flat table.

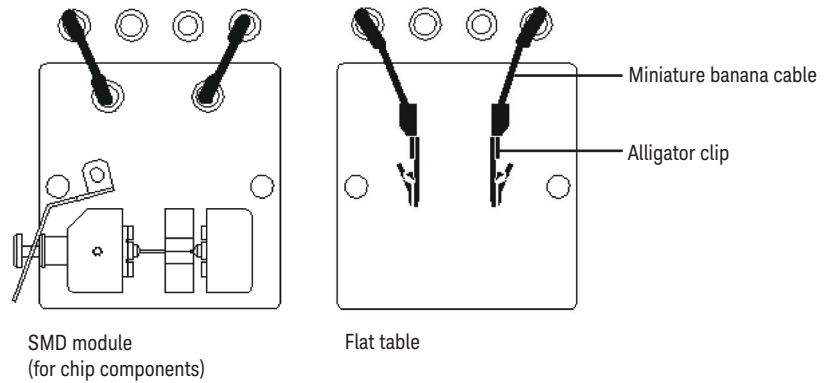

Repackaging the Product

If shipment to a Keysight Technologies service center is required, each product should be repackaged using the original factory packaging materials.

Alternatively, comparable packaging materials may be used. Wrap the product in heavy paper and pack in anti-static plastic packing material. Use sufficient shock absorbing material on all sides of the N1428A to provide a thick, firm cushion and to prevent movement. Seal the shipping container securely and mark it *FRAGILE*.

Operation

This section describes the features of the N1428A, and connections to the B2985B/B2987B and the DUT.



Product Features

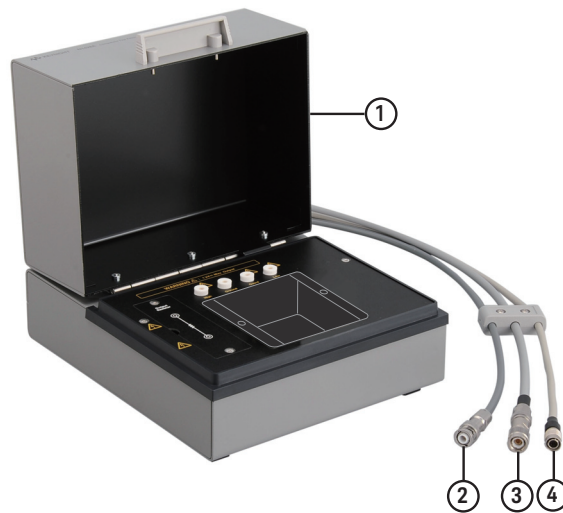

1. *Top cover.* This shields against external electrical noise and enables the interlock function which limits the source voltage from the B2985B/B2987B. When the Top cover is opened, the B2985B/B2987B output voltage will be limited up to ± 21 V.
2. *BNC connector.* This connector provides the source voltage to the N1428A.
3. *Triaxial connector.* The measured signal is carried on the center conductor of this connector.
4. *Interlock connector.* This connector enables the interlock function which limits the source voltage from the B2985B/B2987B. When the Top cover is opened, the B2985B/B2987B output voltage will be limited up to ± 21 V.

Figure 4-3 Terminals and Accessories

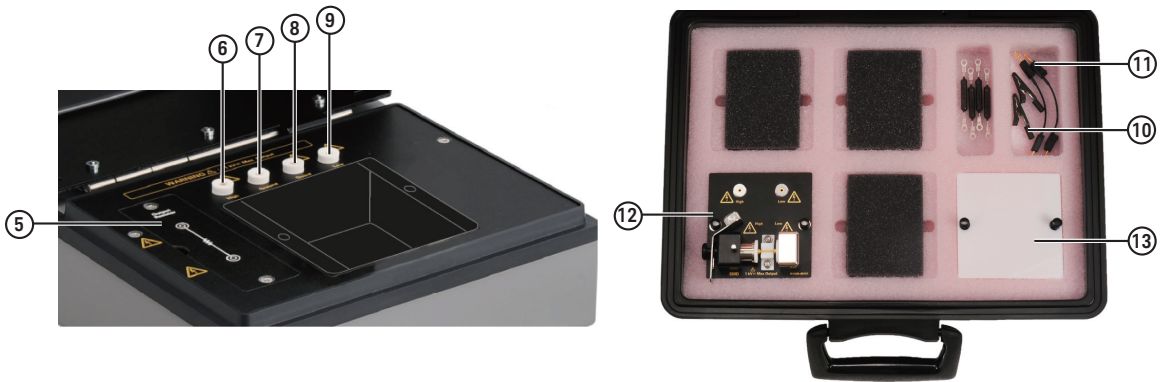

5. *Output Resistor Cover*. Output resistor of the N1428A can be changed. To change the resistor, see [“To Exchange Output Resistor” on page 64](#).
6. *High terminal*. This terminal provides a source voltage of up to 1000 V. This terminal is connected to the center conductor of the BNC connector.
7. *Ground terminal*. This terminal is connected to ground which is the outer shield of the triaxial and BNC connectors.
8. *Guard terminal*. This terminal is connected to the guard which is the inner shield of the triaxial connector.
9. *Low terminal*. This terminal is the measured current path, and is connected to center conductor of the triaxial connector.
10. *Alligator clip*. This is used to measure components which cannot be connected to the SMD module.
11. *Miniature banana-plug cable*. This cable is used to connect the SMD module or alligator clip to the N1428A.
12. *SMD module*. This is used to measure chip components.
13. *Flat table*. This is used when using alligator clips. This table is made of PTFE.

Figure 4-4

Short Bar and Output Resistor

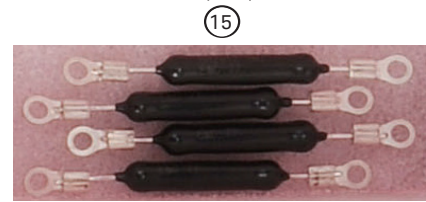

14. *Short Bar*. Normally, this shorting bar is connected in output resistor cover.

15. *Output Resistor*. There are four exchangeable output resistors for the N1428A. Indicated number shows its resistance.

- “100 K” means 100 k Ω .
- “1 M” means 1 M Ω .
- “10 M” means 10 M Ω .
- “100 M” means 100 M Ω .

To Exchange Output Resistor

1. If the N1428A is connected to the B2985B/B2987B, turn the B2985B/B2987B off.
2. Open the Top cover of the N1428A.
3. Remove the two screws holding the output resistor cover, then remove the output resistor cover. See [Figure 4-5](#).
4. Remove the two screws holding the output resistor.
5. Remove the resistor.
6. Place a new resistor so that the two holes are aligned with the two electrodes.
7. Insert and tighten the two screws to hold the resistor.
8. Close the output resistor cover and refasten with two screws.

Figure 4-5 Output Resistor Changing Procedure

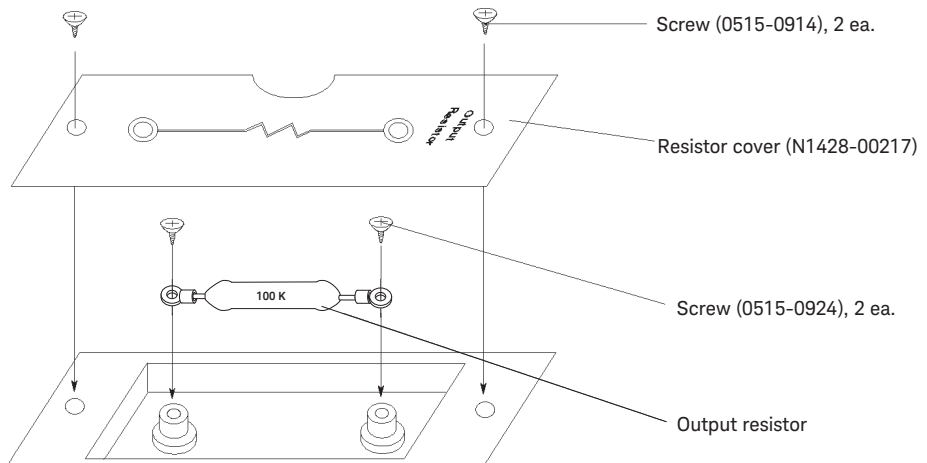

WARNING

Do NOT use an output resistor other than those furnished with the N1428A.
N'utilisez PAS de résistance de sortie autre que celles fournies avec le N1428A.

Making a Measurement

WARNING

Do NOT touch the electrode and Voltage Source terminals while the High Voltage indicator is lit which shows the B2985B/B2987B's output is a high voltage of up to 1000 Vdc. You must operate after turning off the voltage source output and you have confirmed the high voltage indicator is turned off.

NE PAS toucher l'électrode et les bornes de la source de tension lorsque l'indicateur de haute tension est allumé, indiquant que la sortie de B2985B/B2987B est une tension élevée allant jusqu'à 1 000 V CC. Vous devez utiliser l'appareil après la mise hors tension de la sortie de source de tension et après avoir confirmé que l'indicateur de haute tension est éteint.

Step-by-step instructions on how to make a measurement with the N1428A are as follows.

1. Connect the N1428A to the B2985B/B2987B as shown in [Figure 4-2](#).
2. Connect the DUT.
3. Close the Top cover of the N1428A.
4. Follow the measurement instructions described in *Keysight B2980B User's Guide* to perform the measurement.

Be sure to set the B2985B/B2987B's Voltage Source *Low Terminal State* to *FLOATING*.

Checking Procedure

WARNING

Do NOT touch the electrode and Voltage Source terminals while the High Voltage indicator is lit which shows the B2985B/B2987B's output is a high voltage of up to 1000 Vdc. You must operate after turning off the voltage source output and you have confirmed the high voltage indicator is turned off.

NE PAS toucher l'électrode et les bornes de la source de tension lorsque l'indicateur de haute tension est allumé, indiquant que la sortie de B2985B/B2987B est une tension élevée allant jusqu'à 1 000 V CC. Vous devez utiliser l'appareil après la mise hors tension de la sortie de source de tension et après avoir confirmé que l'indicateur de haute tension est éteint.

The N1428A and the B2985B/B2987B is operated with high voltage up to 1000 V. These products are designed that the operator can measure safely. To keep the safe condition, you must execute following checking procedure periodically.



Daily Safety Verification Procedure

1. Connect the N1428A to the B2985B/B2987B as shown in [Figure 4-2](#).
2. Open measurement terminals and close the Top cover of the N1428A.
3. Set source voltage to +22 V.

Be sure to set the Voltage Source *Low Terminal State* to *FLOATING*.

4. Press Voltage Source On/Off switch of the B2985B/B2987B.

Confirm that the On/Off switch turns red and the High Voltage indicator turns on.

5. Open the Top cover of the N1428A.

Confirm that the On/Off switch and the High Voltage indicator turn off immediately.

6. Close the Top cover again.

Confirm that the On/Off switch and the High Voltage indicator still turn off.

If you encountered any errors in checking procedure, contact your nearest Keysight office.

This information is subject to change without notice.
© Keysight Technologies 2021
Edition 1, April 2021



N1424-90100
www.keysight.com