

DSOXEDK Educator's Oscilloscope Training Kit



Lab Guide and Tutorial for Agilent 4000 X-Series Oscilloscopes



Agilent Technologies

Notices

© Agilent Technologies, Inc. 2008-2012

The copyright on this instructional material grants you permission to reprint, modify, and distribute in whole or in part the document for the purpose of training students on Agilent test equipment.

Trademarks

Microsoft®, MS-DOS®, Windows®, Windows 2000®, and Windows XP® are U.S. registered trademarks of Microsoft Corporation.

Adobe®, Acrobat®, and the Acrobat Logo® are trademarks of Adobe Systems Incorporated.

Manual Part Number

54702-97000

Edition

November, 2012

Available in electronic format only

Agilent Technologies, Inc.
1900 Garden of the Gods Road
Colorado Springs, CO 80907 USA

Warranty

The material contained in this document is provided “as is,” and is subject to being changed, without notice, in future editions. Further, to the maximum extent permitted by applicable law, Agilent disclaims all warranties, either express or implied, with regard to this manual and any information contained herein, including but not limited to the implied warranties of merchantability and fitness for a particular purpose. Agilent shall not be liable for errors or for incidental or consequential damages in connection with the furnishing, use, or performance of this document or of any information contained herein. Should Agilent and the user have a separate written agreement with warranty terms covering the material in this document that conflict with these terms, the warranty terms in the separate agreement shall control.

Technology Licenses

The hardware and/or software described in this document are furnished under a license and may be used or copied only in accordance with the terms of such license.

Restricted Rights Legend

If software is for use in the performance of a U.S. Government prime contract or sub-contract, Software is delivered and licensed as “Commercial computer software” as defined in DFAR 252.227-7014 (June 1995), or as a “commercial item” as defined in FAR 2.101(a) or as “Restricted computer software” as defined in FAR 52.227-19 (June 1987) or any equivalent

agency regulation or contract clause. Use, duplication or disclosure of Software is subject to Agilent Technologies’ standard commercial license terms, and non-DOD Departments and Agencies of the U.S. Government will receive no greater than Restricted Rights as defined in FAR 52.227-19(c)(1-2) (June 1987). U.S. Government users will receive no greater than Limited Rights as defined in FAR 52.227-14 (June 1987) or DFAR 252.227-7015 (b)(2) (November 1995), as applicable in any technical data.

Safety Notices

CAUTION

A **CAUTION** notice denotes a hazard. It calls attention to an operating procedure, practice, or the like that, if not correctly performed or adhered to, could result in damage to the product or loss of important data. Do not proceed beyond a **CAUTION** notice until the indicated conditions are fully understood and met.

WARNING

A **WARNING** notice denotes a hazard. It calls attention to an operating procedure, practice, or the like that, if not correctly performed or adhered to, could result in personal injury or death. Do not proceed beyond a **WARNING** notice until the indicated conditions are fully understood and met.

Lab Guide and Tutorial—At a Glance

This EE/Physics Student's Oscilloscope Lab Guide and Tutorial is intended to be used with Agilent Technologies InfiniiVision 4000 X-Series oscilloscopes (DSO and MSO models) that are licensed with the Educator's Training Kit (DSOXEDK).

A Note to the EE/Physics Professor

Dear University EE/Physics Professor and/or Lab Instructor,

This EE/Physics student oscilloscope lab guide and tutorial consists of 15 individual hands-on labs that students can complete in order to become familiar with what an oscilloscope is and how to use one. An oscilloscope is the one measurement tool that your students will use more than any other instrument to test circuit experiments that you assign to them, as well as to test their senior design projects. They will also use oscilloscopes extensively after they graduate and enter the world of today's electronics industry. So it is extremely important that they become proficient in the use of this vital tool.

Each of the 15 labs requires about 15 to 20 minutes to complete. These labs are intended to be used with Agilent's InfiniVision 4000 X-Series oscilloscopes licensed with the Educator's Training Kit option (DSOXEDK). The Educator's Training Kit option enables a broad range of built-in training signals designed specifically for Electrical Engineering and Physics majors. Some of the training signals are very simple, such as sine waves, while other training signals can be quite complex in order to mimic real-world analog and digital signals. No other test equipment is required other than the scope, two passive probes (comes standard with the scope), and one BNC cable.

Before your students begin testing any of their assigned experiments in their first circuits lab, Agilent recommends that they first read Chapter 1, Appendix A and Appendix B of this document as pre-study (homework). Chapter 1 provides an introduction to the oscilloscope, as well as some fundamentals on probing. Appendix A and Appendix B are short tutorials on oscilloscope theory of operation and bandwidth.

Students should then complete the first 6 hands-on labs in Chapter 2 of this document (Basic Oscilloscope and WaveGen Measurement Labs) during their first lab session. Labs #1 through #3 should provide students with sufficient knowledge to setup oscilloscope scaling (V/div and s/div) while using edge triggering so that they can begin making basic oscilloscope measurements during their initial lab experiments that you assign. Lab #4 teaches them how to save measurement results so that they can begin documenting their measurement results to include in lab reports that you may require. Lab #5 teaches students how to adjust probe compensation. And Lab #6 teaches students how to use the optional built-in WaveGen function generator. This particular lab only requires about 5 minutes to complete, but requires that your scopes have this licensed option.

The "Advanced" hands-on oscilloscope labs presented in Chapter 3 of this document are optional. Students may choose to complete some or all of these labs if they are interested in learning more about how to use some of the more advanced oscilloscope measurement features. Alternatively, professors may choose to assign specific labs they consider as important for students to complete. Note that this lab guide was structured for flexibility in its use.

Sincerely,



Johnnie Hancock
Oscilloscope Education Program Manager
Agilent Technologies

Contents

Lab Guide and Tutorial—At a Glance	3
A Note to the EE/Physics Professor	4

1 Getting Started

Oscilloscope Probing	9
Getting Acquainted with the Front Panel	11

2 Basic Oscilloscope and WaveGen Measurement Labs

Lab #1: Making Measurements on Sine Waves	16
Lab #2: Learning the Basics of Oscilloscope Triggering	23
Lab #3: Triggering on Noisy Signals	29
Lab #4: Documenting and Saving Oscilloscope Test Results	34
Lab #5: Compensating your Passive 10:1 Probes	39
Computing the Proper Amount of Capacitive Compensation	42
Probe Loading	43
Lab #6: Using the WaveGen built-in Function Generator	45

3 Advanced Oscilloscope Measurement Labs

Lab #7: Triggering on a Digital Burst using Trigger Holdoff	48
Lab #8: Triggering on, Capturing, and Analyzing an Infrequent Event	52
Lab #9: Capturing a Single-shot Event	56
Lab #10: Performing Automatic Parametric Measurements on Digital Waveforms	59
Lab #11: Using the Scope's Zoom Timebase to Perform Gated Measurements	65
Lab #12: Phase Delay Measurements and Lissajous Waveforms	70
Lab #13: Using Oscilloscope Waveform Math	74
Lab #14: Using Peak Detect to Overcome Under-sampling	78
Lab #15: Using Segmented Memory to Capture More Waveforms	82

4 Summary

Related Agilent Literature	90
----------------------------	----

A Oscilloscope Block Diagram and Theory of Operation

DSO Block Diagram	92
ADC Block	92
Attenuator Block	93
DC Offset Block	93
Amplifier Block	93
Trigger Comparator and Trigger Logic Blocks	94
Timebase and Acquisition Memory Blocks	95
Display DSP Block	96

B Oscilloscope Bandwidth Tutorial

Defining Oscilloscope Bandwidth	97
Required Bandwidth for Analog Applications	98
Required Bandwidth for Digital Applications	99
Rule of Thumb	100
Step 1: Determine fastest actual edge speeds	100
Step 2: Calculate f_{knee}	100
Step 3: Calculate scope bandwidth	101
Example	101
Digital Clock Measurement Comparisons	102

Index

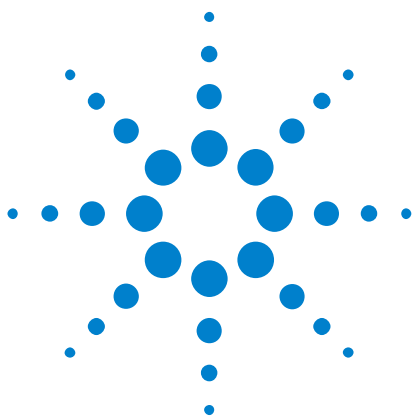

1 Getting Started

Oscilloscope Probing 9

Getting Acquainted with the Front Panel 11

Oscilloscopes are a critical tool for making voltage and timing measurements on today's analog and digital electrical circuits. When you finally graduate from Electrical Engineering school and enter the electronics industry, you will probably discover that an oscilloscope is the one measurement tool that you will use more than any other instrument to test, verify, and debug your designs. Even while in your EE or Physics program at your particular university, an oscilloscope is the measurement tool that you will use most often in your various circuits labs to test and verify your lab assignments and designs. Unfortunately many students never fully grasp how to use an oscilloscope. Their use-model is often one of randomly twisting knobs and pressing buttons until a picture close to what they are looking for magically appears on the scope's display. Hopefully after completing this series of short labs you will have a better understanding of what a scope is and how to use one more efficiently.

So, what is an oscilloscope? An oscilloscope is an electronic measurement instrument that unintrusively monitors input signals and then graphically displays these signals in a simple voltage versus time format. The type of oscilloscope that your professor used during his or her undergraduate studies was probably one that was based entirely on analog technology. These older technology oscilloscopes, typically called analog scopes, had limited bandwidth (which is discussed in Appendix B), did not perform any kind of automatic measurements, and also required that the input signal be repetitive (continuously occurring and repeating input signal).

The type of oscilloscope that you will be using in this series of labs, and probably throughout the rest of your university studies, is called a digital storage oscilloscope; sometimes simply referred to as a DSO. Or you may be using a mixed signal oscilloscope, which combines traditional DSO measurements along with logic analysis measurements and is sometimes referred to as an MSO. Today's DSOs and MSOs can capture and display either repetitive or single-shot signals, and they often include an array of automatic measurements and analysis capabilities that should enable you to characterize your designs and student experiments faster and more accurately than your professor was able to do back in his or her undergraduate days.



1 Getting Started

To learn more about the fundamentals of oscilloscopes, download Agilent's application note titled *Evaluating Oscilloscope Fundamentals*. This publication is listed in the “[Related Agilent Literature](#)” section of this document with instructions on how to download. If you are primarily interested in learning about the theory of operation of an oscilloscope, refer to Appendix A in this document.

The best way to quickly learn how to use an oscilloscope and understand what it can do for you, is to first get acquainted with some of the most important controls on an oscilloscope, then simply begin using one to measure some basic signals, such as sine waves. When licensed with the DSOXEDK Educator's Training Kit option, Agilent Technologies InfiniiVision 4000 X-Series oscilloscopes, shown in [Figure 1](#), can generate an array of different analog and digital training signals. We will be using many of these signals in this series of short labs to help you get acquainted with how to use this most important electronic signal measuring instrument... the oscilloscope.



Figure 1 Agilent InfiniiVision 4000 X-Series oscilloscope

Oscilloscope Probing

The first task when making oscilloscope measurements is typically to connect the oscilloscope probes between the device-under-test and the scope's input BNCs. Oscilloscope probes provide a relatively high input impedance termination (high resistance with low capacitance) at the test point. A high impedance connection is important in order to isolate the measuring instrument from the circuit being tested since we don't want the oscilloscope and its probe to change the characteristics of the signals under test.

There are a variety of different kinds of oscilloscope probes that are used for specific types of measurements, but the probes that you will be using today are the most commonly used type of probe and are called passive 10:1 voltage probes as shown in [Figure 2](#). "Passive" simply means that this type of probe does not include any "active" components such as transistors or amplifiers. "10:1" means that this probe will attenuate the input signal received at the scope's input by a factor of 10.

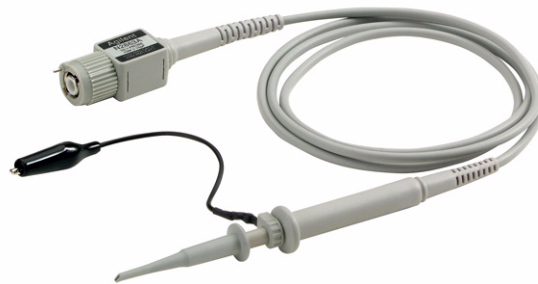

Figure 2 Passive 10:1 voltage probe

When using a standard 10:1 passive probe, all scope measurements should be performed between the signal test point and ground. In other words, you **must** connect the probe's ground clip to ground. You **cannot** measure voltages across a mid-circuit component using this type of probe. If you need to measure the voltage across a component that is not grounded, you could either use the scope's subtraction math function (covered during lab #13) while measuring the signals at both ends of the component relative to ground using two channels of the scope, or you could use a special differential active probe. Also note that a circuit should never be completed using the oscilloscope.

[Figure 3](#) shows an electrical model of a 10:1 passive probe when connected to an oscilloscope using the scope's default 1 M Ω input selection, which is required when using this type of probe. Note that many higher bandwidth scopes also have a user-selectable 50 Ω input

termination selection often used for active probe terminations and/or used when inputting a signal directly from a $50\ \Omega$ source using a $50\ \Omega$ BNC coaxial cable.

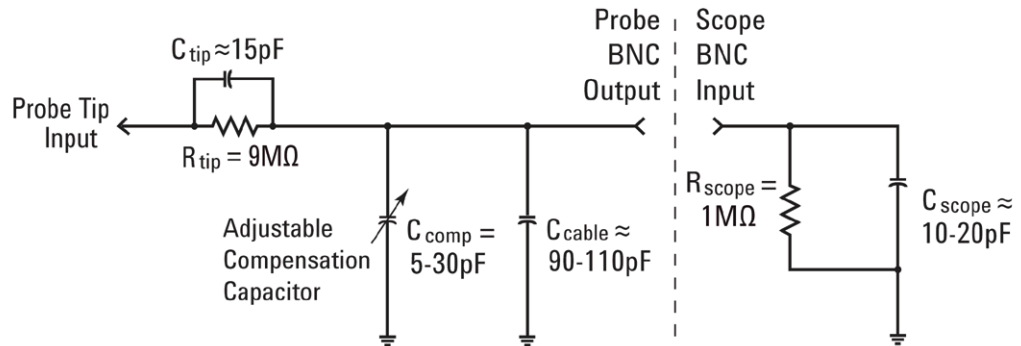

Figure 3 Simplified schematic of a passive 10:1 probe connected to the scope's $1\ \text{M}\Omega$ input impedance

Although the electrical model of the passive probe and scope includes both inherent/parasitic capacitance (not designed-in) as well as intentionally designed-in compensation capacitance networks, let's ignore these capacitive elements for now and analyze the ideal signal behavior of this probe/scope system under low-frequency or dc input conditions.

After we remove all of the capacitive components from our probe/scope electrical model, what remains is just a $9\ \text{M}\Omega$ probe tip resistor in series with the scope's $1\ \text{M}\Omega$ input impedance. The net input resistance at the probe tip is then $10\ \text{M}\Omega$. Using Ohm's law, you can see that the voltage level received at the scope's input is then 1/10th the voltage level that is at the probe tip ($V_{scope} = V_{probe} \times (1\ \text{M}\Omega/10\ \text{M}\Omega)$).

This means that with a 10:1 passive probe the dynamic range of the oscilloscope measurement system has been extended. In other words, you can measure signals with 10X higher amplitude as compared to signals that you could measure using a 1:1 probe. In addition, the input impedance of your oscilloscope measurement system (probe + scope) is increased from $1\ \text{M}\Omega$ to $10\ \text{M}\Omega$. This is a good thing since a lower input impedance could load your device-under-test (DUT) and possibly change actual voltage levels within your DUT, which is not a good thing. And although a net input impedance of $10\ \text{M}\Omega$ is indeed large, you must remember that this amount of loading impedance must be considered in relationship to the impedance of the device you are probing. For example, a simple op amp circuit with a $100\ \text{M}\Omega$ feedback resistor may give some false readings on a scope.

When we get to Lab #5 (Compensating your Passive 10:1 Probes), we will come back to this passive probe model and address the capacitive components. These elements in the probe/scope electrical model will affect the dynamic/ac performance of the combined oscilloscope and probing system.

Getting Acquainted with the Front Panel

Let's begin by first getting acquainted with the most important controls/knobs on your oscilloscope. Near the top of your oscilloscope are the "Horizontal" controls shown in [Figure 4](#). The larger knob sets the horizontal scaling in seconds/division. This control sets the X-axis scaling of the displayed waveform. One horizontal "division" is the Δ -time between each vertical grid line. If you want to view faster waveforms (higher frequency signals), then you will set the horizontal scaling to a smaller sec/div value. If you want to view slower waveforms (slower frequency signals), then you typically set the horizontal scaling to a higher sec/div setting. The smaller knob in the Horizontal section sets the horizontal position of the waveform. In other words, with this control you can move the horizontal placement of the waveform left and right. The scope's horizontal controls (s/div and position) are often called the scope's main "timebase" controls.



Figure 4 Oscilloscope horizontal (X-axis) controls

The controls/knobs near the bottom of the oscilloscope (refer to [Figure 5](#)) in the Vertical section (just above the input BNCs) set the vertical scaling of the oscilloscope. If you are using a 2-channel oscilloscope, then there will be two pairs of vertical scaling controls. If you are using a 4-channel oscilloscope, then there will be four pairs of vertical scaling controls. The larger knob for each input channel in the Vertical section sets the vertical scaling factor in Volts/division. This is the Y-axis graphical scaling of your waveforms. One vertical "division" is the Δ -volts between each horizontal grid line. If you want to view relatively large signals (high peak-to-peak voltages), then you would typically set the Volts/div setting to a relatively high value. If viewing small input signal levels, then you would set the

Volts/div setting to a relatively low value. The smaller controls/knobs for each channel in the Vertical section are the position/offset controls. You use this knob to move the waveform up and down on the screen.

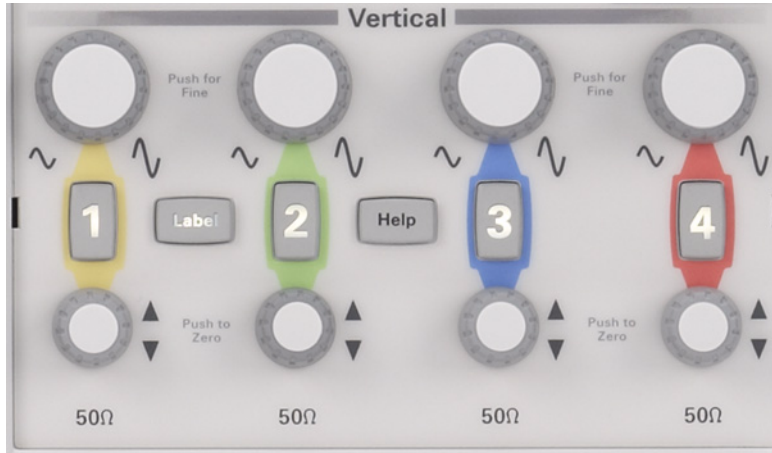

Figure 5 Oscilloscope vertical (Y-axis) controls

Another very important oscilloscope setup variable is the trigger level control/knob shown in [Figure 6](#). This control knob is located near the center of your scope's front panel; just below the section labeled **Trigger**. Triggering is probably the least understood aspect of an oscilloscope, but it is one of the most important capabilities of a scope that you should understand. We will cover oscilloscope triggering in more detail as we get into the hands-on labs.



Figure 6 Oscilloscope trigger level control

When reading the instructions in the following labs, anytime you see a bold word within brackets, such as **[Help]**, this is referring to a front panel key (or button) located on the right-hand side of the oscilloscope. When the key is pressed, a unique menu with “softkey” selections associated with that particular front panel function will be activated. “Softkeys” are the 6 keys/buttons located below the scopes display. The functions of these keys change depending upon which menu has been activated. You can use the physical buttons to select menus, or take advantage of the touch screen display.

Now locate the **Entry** control knob shown in [Figure 7](#). This is the knob just to the right of the scope's display in the dark shaded area. Traditionally, scope users had to use this knob quite frequently to change an array of setup variables and selections that don't have dedicated front panel controls. With the InfiniiVision 4000 X-Series scope's new touchscreen display, menu selections can be made directly without using this knob. If you prefer using the knob, be aware that any time you see a green selection, this is an indication that the **Entry** knob can control this variable. Note that this knob is also used to set the waveform intensity level by first pressing the intensity button below it. Let's begin making measurements on your oscilloscope!



Figure 7 Oscilloscope general-entry control

1 Getting Started

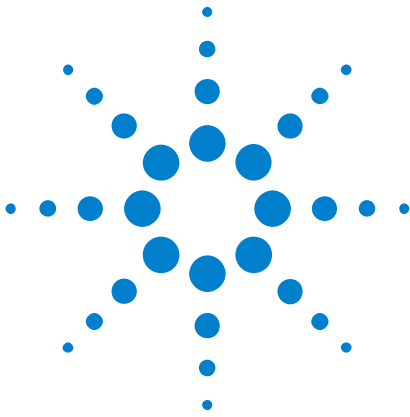

2 Basic Oscilloscope and WaveGen Measurement Labs

Lab #1: Making Measurements on Sine Waves	16
Lab #2: Learning the Basics of Oscilloscope Triggering	23
Lab #3: Triggering on Noisy Signals	29
Lab #4: Documenting and Saving Oscilloscope Test Results	34
Lab #5: Compensating your Passive 10:1 Probes	39
Lab #6: Using the WaveGen built-in Function Generator	45



Lab #1: Making Measurements on Sine Waves

In this 1st lab you will learn how to use the scope's horizontal and vertical scaling controls in order to properly setup the scope to display a repetitive sine wave. In addition, you will learn how to make some simple voltage and timing measurements on this signal.

- 1 Connect one oscilloscope probe between the channel-1 input BNC and the output terminal labeled “Demo1” as shown in Figure 8. Connect this probe's ground clip to the center terminal (ground).

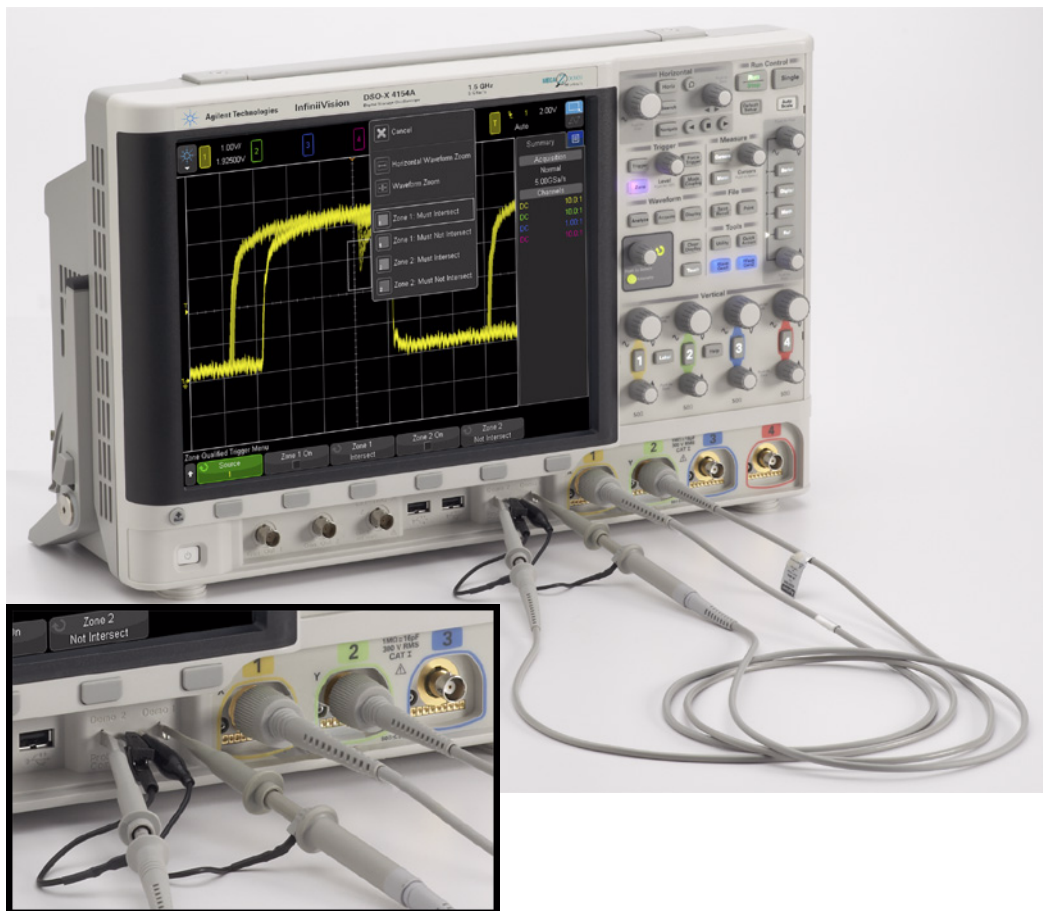

Figure 8 Connecting probes between the channel-1 and channel-2 inputs to the training signals output terminals

- 2 Connect a second oscilloscope probe between the channel-2 input BNC and the output terminal labeled “Demo2” as shown in Figure 8. Connect this probe's ground clip to the center terminal.
- 3 Press the [**Default Setup**] key near the upper right-hand section of the front panel.

Default Setup will put the oscilloscope into a factory preset configuration. Not only will this set the scope's X and Y scaling factors to preset values, but it will also turn off any special modes of operation that one of your fellow students may have used.

- 4 Press the [**Help**] front panel key (near the channel-2 vertical controls).
- 5 Tap the **Training Signals** softkey on the screen, or press the corresponding button below the display. Close the help guide that appears by tapping the red X on the upper right of the pop-up.
- 6 Select a training signal from the list by tapping the green **Training Signals** button on the lower left of the screen, and select **Sine**.

There should now be a sine wave present on the Demo1 terminal, but it is not yet recognizable using the scope's default scaling factors. We will now adjust the scope's vertical and horizontal settings to expand and center this waveform on the display.

- 7 Turn the channel-1 V/div knob clockwise until you see the displayed waveform covering more than $\frac{1}{2}$ of the screen. The correct setting should be **500 mV/div**, which is displayed as "500mV/" near the upper left-hand side of the display. Additionally, tapping the displayed value will pop up a menu that can be used to explicitly enter the voltage scale.
- 8 Turn the s/div knob (large knob in the Horizontal section) clockwise until you observe more than two periods of a sine wave across the display. The correct setting should be **50 ns/div**, which is displayed as "50.00ns/" near the middle of the top part of the display. Your scope's display should now appear similar to [Figure 9](#). From this point forward we will simply refer to this as the scope's "timebase" setting. Additionally, tapping **50 ns/div** will pop up a menu that can be used to explicitly enter the timebase setting.

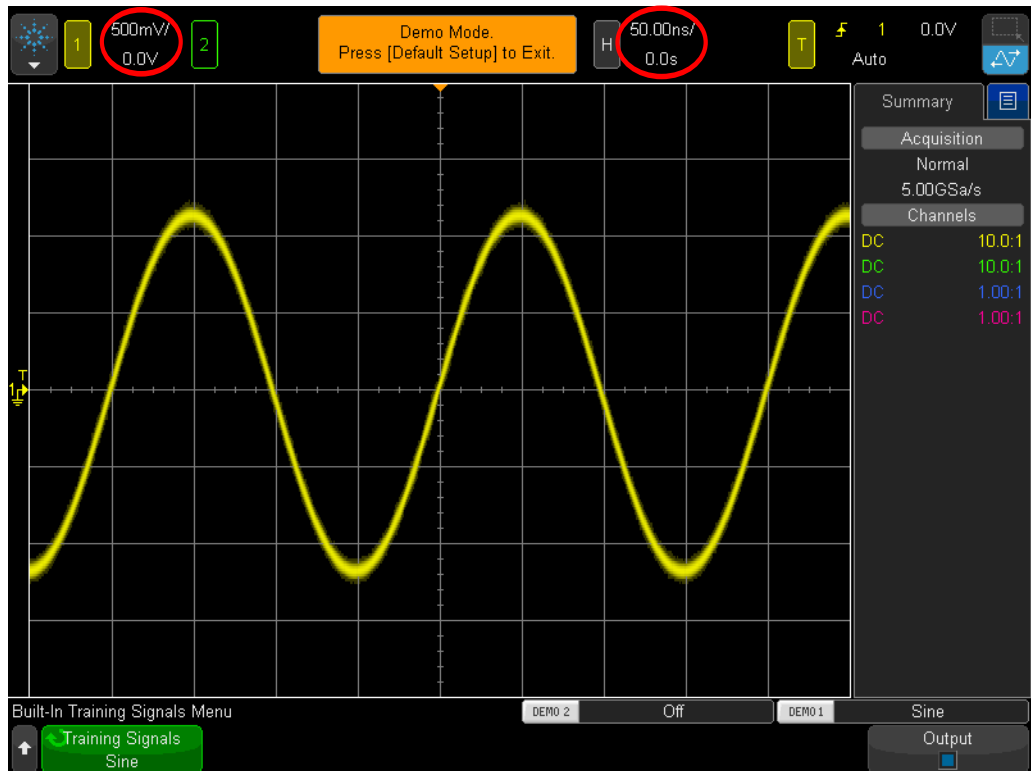

Figure 9 Initial setup to view the sine wave training signal

- 9 Rotate the Horizontal position knob to move the waveform left and right. Alternatively, tap the icon shown below in [Figure 10](#), until the lower half is colored blue. You can now swipe your finger across the waveform to move it left and right.

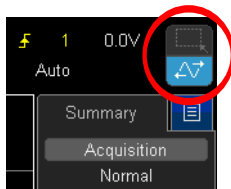

Figure 10 Blue touchscreen option icon

- 10 Now that we have learned the ways to shift the waveform, press the Horizontal position knob to set it back to zero (0.0 seconds at center-screen).
- 11 Rotate the channel-1 vertical position knob to move the waveform up and down. Notice that the channel offset on the left also moves up and down and tells us where 0.0 Volts (ground level) is located on this waveform.

- 12** Press the channel-1 vertical position knob to set the ground offset back to center-screen. Alternatively, tap the channel offset in the upper left; press the Channel 1 Offset value to modify.

Let's now make some measurements on this repetitive sine wave. Notice that the oscilloscope's display is basically an X versus Y graph. On our X-axis (horizontal) we can measure time, and on our Y-axis (vertical) we can measure voltage. In many of your EE or Physics class assignments, you have probably computed and graphed electrical signals in a similar, but static, format on paper. Or, perhaps you have used various PC software applications to automatically graph your waveforms. When a repetitive input signal is applied to an oscilloscope, we are able to observe dynamic (continuously updated) graphing of our waveforms.

Our X-axis consists of 10 major divisions across the screen with each major division being equal to the sec/div setting. In this case, each horizontal major division represents 50 nanoseconds of time, assuming that the scope's timebase is set to 50.0 ns/div as instructed earlier. Since there are 10 divisions across the screen, then the scope is showing 500 ns of time (50.0 ns/div x 10 divisions) from the left side of the display to the right side of the display. Notice that each major division is also divided into 4 minor divisions, which are displayed as tick marks on the center horizontal axis. Each minor division would then represent $1/4 \text{ div} \times 50 \text{ ns/div} = 12.5 \text{ ns}$.

Our Y-axis consists of 8 major divisions vertically with each major division being equal to the V/div setting, which should be set at 500 mV/div. At this setting, the scope can measure signals as high as 4 Vp-p (500 mV/div x 8 divisions). Each major division is divided into 5 minor divisions. Each minor division, represented as tick marks on the center vertical axis, then represents 100 mV each.

- 13** Estimate the period (T) of one of these sine waves by counting the number of divisions (major and minor) from the 0.0 V level of a rising edge (center-screen) to the 0.0 V level of the next rising edge; then multiply by the s/div setting (should be 50.0 ns/div).

$$T = \underline{\hspace{2cm}}$$

- 14** What is the frequency of this sine wave ($F = 1/T$).

$$F = \underline{\hspace{2cm}}$$

Let's now estimate the peak-to-peak voltage level of these sine waves, but first, let's make a few minor adjustments to our vertical settings that may help us perform this measurement more accurately.

- 15** Adjust the channel-1 vertical position knob (smaller knob below the lighted "1" key) until the negative peaks of the sine waves intersect with one of the major graticules (or grid lines).

- 16 Next, adjust the horizontal position knob (smaller knob near the top of front panel) until one of the positive peaks of the sine waves intersect with the center vertical axis that has the minor division tick marks. Alternatively, you can drag the waveform left or right on the screen.
- 17 Now, estimate the peak-to-peak voltage of this sine wave by counting the number of divisions (major and minor) from the sine wave's negative peak to the positive peak; then multiply by the V/div setting (should be 500 mV/div).

$$V_{p-p} = \underline{\hspace{2cm}}$$

Let's now use the scope's "cursors" function to make these same voltage and timing measurements; but without having to count divisions and then multiply by scaling factors. First, visually locate the [**Cursors**] button in the Measure section of the front panel as shown in [Figure 12](#).



Figure 11 Measurement Cursors knob

- 18 Press [**Cursors**]; orange flags will appear on the bottom and right side of the waveform. By default, all cursor values are set to 0.
- 19 Drag the X1 cursor with your finger to align with a rising edge of the waveform. Hint: Align the cursor at a point on the waveform where it crosses one of the horizontal grid lines.
- 20 Next, drag cursor X2 so it intersects with the next rising edge of the sine wave at the same voltage level.
- 21 Next, drag the Y1 cursor so that it intersects with the negative peaks of the sine waves.
- 22 Finally, drag the Y2 cursor so that it intersects with the positive peaks of the sine waves.

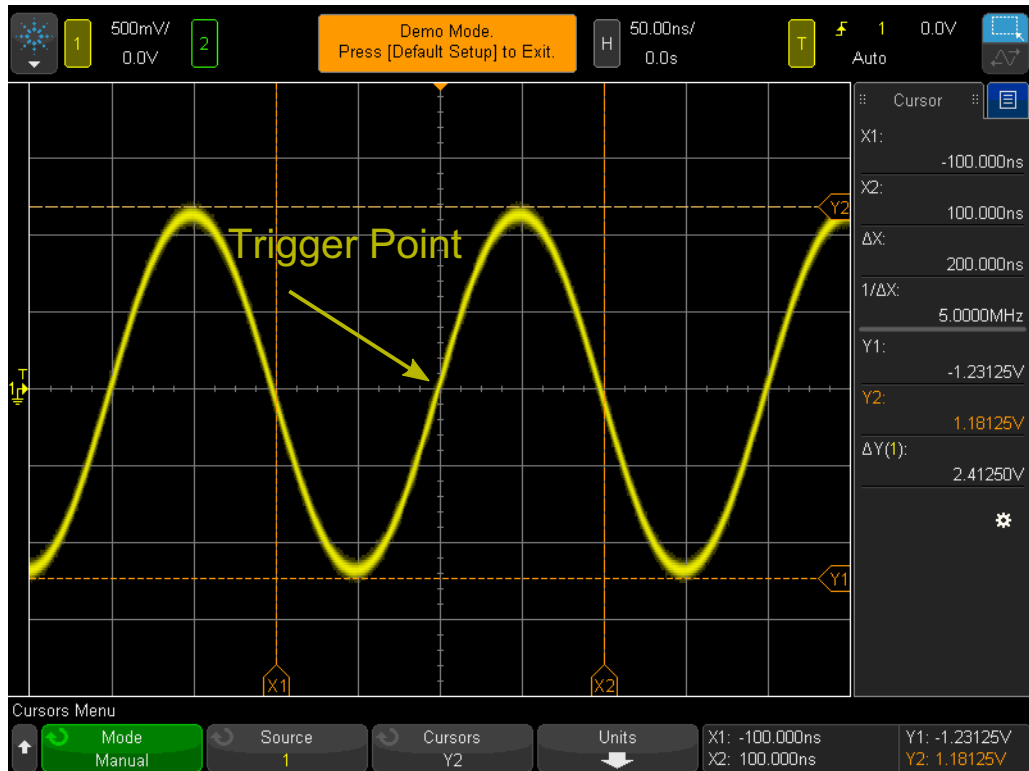

Figure 12 Using the scope's cursor measurements

- 23 Your screen should now be similar to [Figure 12](#), What are the period, frequency, and peak-to-peak voltage of this signal (cursor read-out is on the right-hand side of the display)?

$$\Delta X = \underline{\hspace{2cm}}$$

$$1/\Delta X = \underline{\hspace{2cm}}$$

$$\Delta Y(1) = \underline{\hspace{2cm}}$$

The most common method used to measure time and voltage on an oscilloscope is the “division counting” method we used first. Although divisions must be counted and then multiplied by scope settings, engineers that are familiar with their scopes can quickly estimate of the voltage and timing parameters of their signals – and sometimes a rough estimation is all that is required to know if a signal is valid or not.

Using cursors should provide a slightly more accurate measurement and take the guess work out of the measurement. Most of today's scopes also provide an even more accurate and faster way to make many measurements automatically. We will come back to using the scope's

2 Basic Oscilloscope and WaveGen Measurement Labs

automatic parametric measurements during lab #10 when we begin to make some measurements on some digital signals. But for now, we need to take a step back and learn about oscilloscope triggering.

Lab #2: Learning the Basics of Oscilloscope Triggering

As mentioned earlier, oscilloscope triggering is probably the most important capability of an oscilloscope that you should understand if you want to get the most out of your oscilloscope measurements. This is especially important when attempting to make measurements on many of today's more complex digital signals. Unfortunately, oscilloscope triggering is often the least understood aspect of oscilloscope operation.

You can think of oscilloscope “triggering” as “synchronized picture taking”. When an oscilloscope is capturing and displaying a repetitive input signal, it may be taking tens of thousands of pictures per second of the input signal. In order to view these waveforms (or pictures), the picture-taking must be synchronized to “something”. That “something” is a unique point in time on the input signal, or perhaps a unique point in time based on a Boolean combination of input signals (logic “pattern” triggering) while using multiple channels of the oscilloscope.

An analogous situation to oscilloscope triggering is that of a photo finish of a horse race. Although not a repetitive event, the camera's shutter must be synchronized to the first horse's nose at the instant in time that it crosses the finish line. Randomly taking photos of the horse race sometime between the start and end of the race would be analogous to viewing untriggered waveforms on a scope.

To better understand oscilloscope triggering, let's make some more measurements on our familiar sine wave that we used in Lab #1.

- 1 Ensure that your two oscilloscope probes are still connected between the terminals labeled Demo1 & Demo2 and Channel-1 & Channel-2 input BNCs respectively.
- 2 Press **[Default Setup]** on the scope's front panel.
- 3 Press **[Help]**; then tap the **Training Signals** softkey.
- 4 Select the “**Sine**” training signal from the **Training Signals** menu.
- 5 Set channel 1's V/div to **500 mV/div**.
- 6 Set the scope's timebase to **50.00 ns/div**.
- 7 Press the **[Trigger]** front panel key.

Your scope's display should now look similar to [Figure 13](#). Using the scope's default trigger conditions, the scope should be triggering on a rising (slope selection) edge (trigger type selection) of the sine wave that is being probed and captured by channel-1 (source selection) as this signal crosses the 0.0 V level (trigger level setting). This point in time is shown at center-screen (both horizontally and vertically) if the horizontal position control is set to 0.0 sec (default setting). Waveform data captured before

the trigger point (left side of display) is considered negative time data, while waveform data captured after the trigger point (right side of display) is considered positive time data.

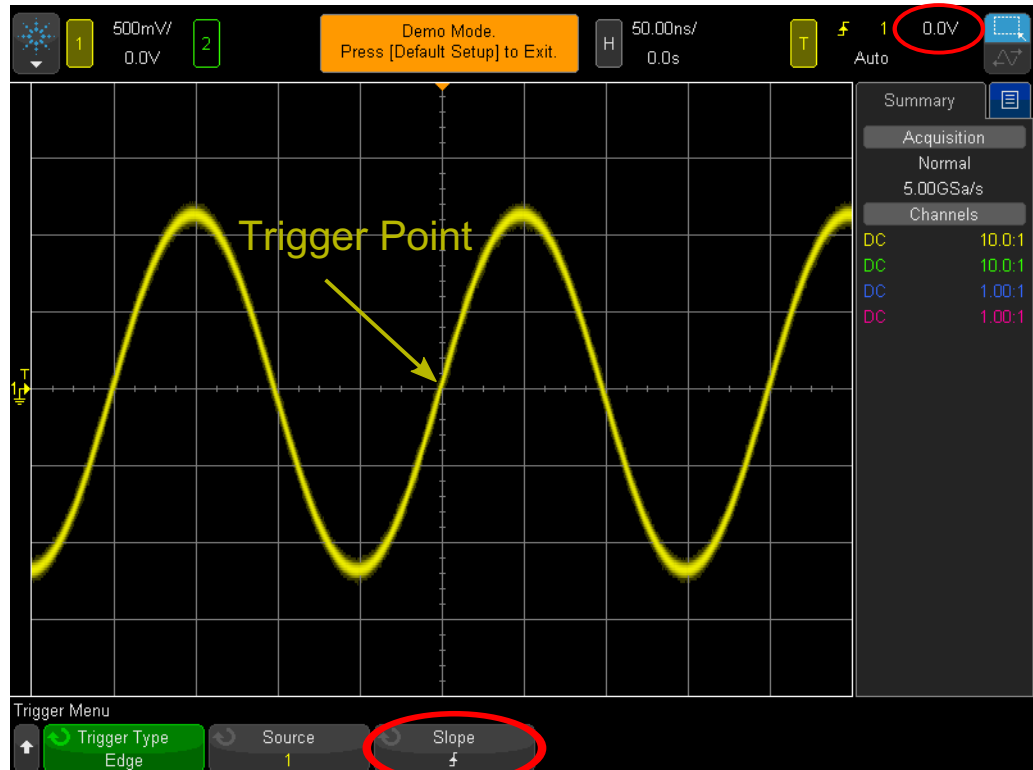

Figure 13 Triggering the oscilloscope on a rising edge of channel-1 at 0.0 Volts

Note that the “filled” orange triangle near the top of the display indicates where the trigger time point (0.0 s) is located. If you adjust the horizontal delay/position, this orange triangle will move away from center-screen. The “hollow” orange triangle at center-screen (only visible if the delay/position is not 0.0 s) indicates the time location of the delay setting when using the scope’s default “center” reference.

- 8 Rotate the trigger level knob clockwise to increase the trigger level voltage setting.
- 9 Rotate the trigger level knob counter-clockwise to decrease the trigger level voltage setting.

As you increase the trigger level voltage setting, you should observe the sine wave shifting in time to the left. If you decrease the trigger level voltage setting, the sine wave will shift to the right. When you initially turn the trigger level knob, a horizontal orange trigger level indicator will appear, and the exact trigger voltage setting is always displayed in the upper right-hand corner of the scope’s display. If you stop rotating the

trigger level knob, the orange trigger level indicator will time-out and disappear after a few seconds. But there is still a yellow trigger level indicator shown outside the waveform graticule area on the left to indicate where the trigger level is set relative to the waveform. You can also tap the trigger level voltage in the top right of the display to explicitly adjust its value.

10 Set the trigger level to exactly **500 mV** (1 division above center-screen). Note that the exact trigger level is displayed in the upper right-hand corner of the display.

11 Tap the **Slope** softkey and then select a **Falling** edge trigger condition.

The sine wave should now appear to be inverted 180 degrees with a falling edge of the waveform synchronized to center-screen as shown in [Figure 14](#).

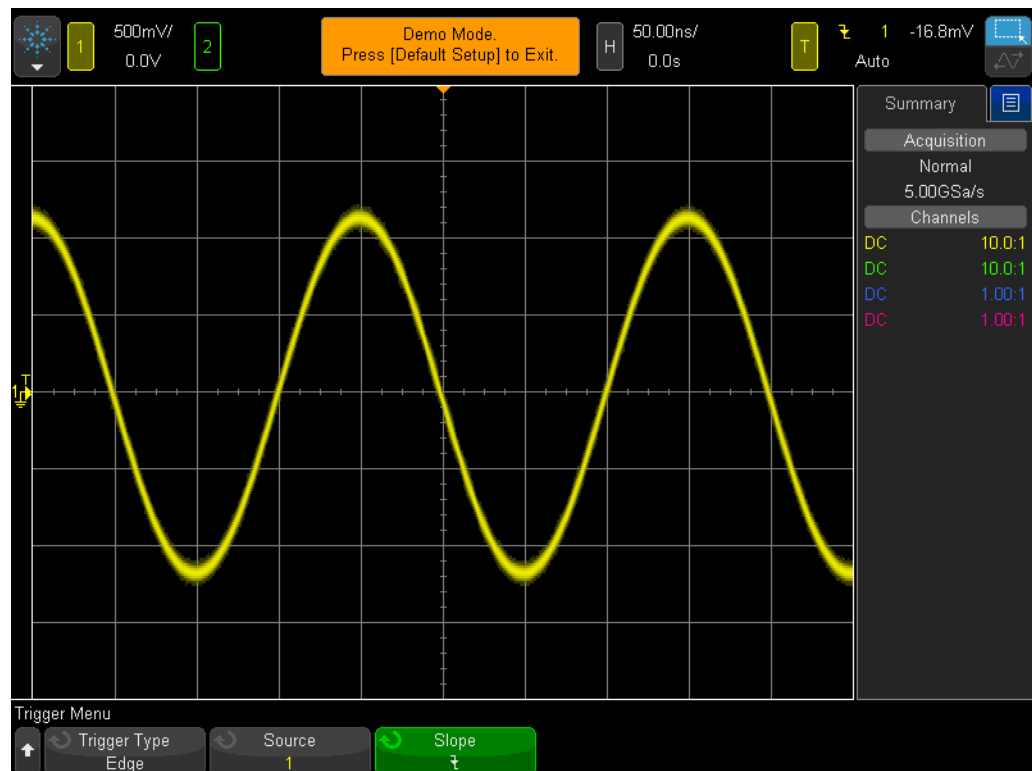

Figure 14 Triggering on the falling edge of the sine wave at + 500 mV

12 Increase the trigger level voltage setting until the orange level indicator is above the positive peaks of the sine wave (approximately +1.5 V).

With the trigger level set above the sine wave, the scope's acquisition and display (repetitive picture taking) is no longer synchronized to the input signal since the scope can't find any edge crossings at this particular trigger level setting. Your scope's display should now look similar to [Figure 15](#). The scope is now "auto triggering".

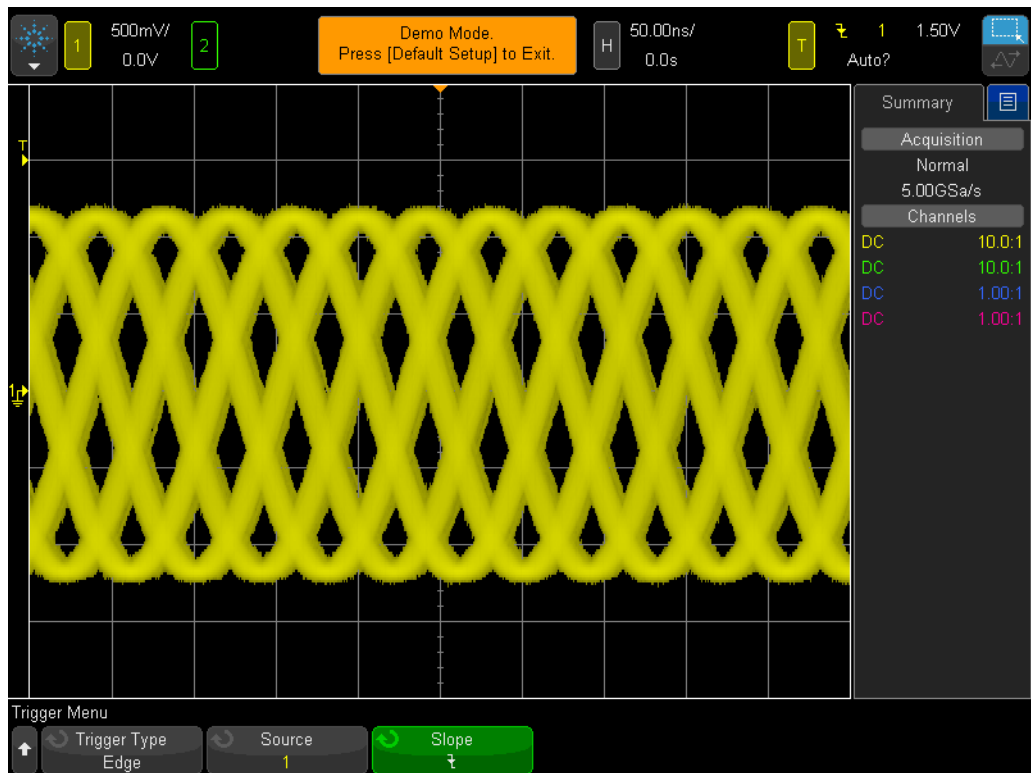

Figure 15 Auto triggering with the trigger level set above the input signal

Auto Trigger is the scope's default trigger mode. When the scope is using the **Auto Trigger** mode, if the scope doesn't find a valid trigger condition (edge crossing of the sine wave in this case) after a period of time (time varies and depends on the scope's timebase setting), then the scope will generate its own asynchronous trigger and begin taking pictures (acquisitions) of the input signal at random times. Since the "picture taking" is now random, rather than synchronized to the input signal, all we see is a "blur" of waveforms across the screen. This "blur" of waveforms should be a clue to us that our scope is not triggering on the input signal.

- 13 Press the trigger level knob to automatically set the trigger level to the approximate 50% level.
- 14 Disconnect the channel-1 probe from the Demo1 terminal.

With the channel-1 probe disconnected from our signal source, we should now see a baseline 0.0 V DC signal. Since with this 0.0 V DC signal we no longer have any edge crossings, and hence the scope has nothing to trigger on; the scope again “auto triggers” in order to show us this DC level signal.

In addition to the default **Auto Trigger** mode, the oscilloscope also has another user-selectable trigger mode called the **Normal Trigger** mode. Let’s now see how the **Normal Trigger** mode differs from the **Auto Trigger** mode.

- 15 Re-connect the channel-1 probe to the Demo1 terminal. You should see the triggered sine wave again.
- 16 Press the [**Mode/Coupling**] front panel key (to the right of the trigger level knob).
- 17 In the upper right of the display, to the right of the yellow T box (trigger settings), tap **Auto** to change the trigger mode selection from **Automatic** to **Normal**. At this point you should not see any difference in the displayed waveform, and the word **Auto** will change to **Trig’d**.
- 18 Disconnect the channel-1 probe from the Demo1 terminal again.

You should now see the last acquisition (last picture) that occurred before the probe was disconnected. We do not see the 0.0 V DC level trace that the **Auto Trigger** mode displayed. When the **Normal Trigger** mode is selected, the scope will only display waveforms *if and only if* the scope detects valid trigger conditions (edge crossings in this case). Also notice the question mark that now appears after **Trig’d**? This means that the scope is in **Normal Trigger** mode, but has not triggered on anything in a while.

- 19 Rotate the trigger knob clockwise in order to set the trigger level at +1.50 V (which is above our sine wave).
- 20 Re-connect the channel-1 probe to the Demo1 terminal.

The sine wave is now connected and being input to the scope, but where is our repetitive display of this signal? Since we are using the **Normal** trigger mode, the scope still requires valid edge crossings, but since the trigger level is set above the waveform (@ +1.50 V), there are no valid edge crossings. So as you can see with the **Normal** trigger mode, we don’t have any clue as to where our waveform is, and we can’t measure DC.

- 21 Press the trigger level knob to automatically set the trigger level to the approximately 50% level. Your scope should begin to show repetitive waveforms again.

Some older scopes use to refer to what we today call the **Normal** trigger mode as the **Triggered** trigger mode, which may actually be a more descriptive term for this triggering mode since in this mode the scope only triggers when it finds a valid trigger condition, and will not generate an automatic trigger (asynchronous trigger to generate asynchronous picture taking). And it is a bit of an oxymoron that the **Normal** trigger mode is not

the “normally” used trigger mode, and it is not the scope’s default trigger mode. The trigger mode that is normally used is the **Auto** trigger mode, which is the scope’s default trigger mode.

As this point you may be wondering when to use the **Normal** trigger mode. The **Normal** trigger mode should be used when the trigger event occurs very infrequently (including single-shot events). For example, if you had the scope setup to display a very narrow pulse, but if this pulse occurs at just a 1 Hz rate (once per second), if the scope’s trigger mode was set to the **Auto** trigger mode, then the scope would generate lots of asynchronously-generated automatic triggers and would not be able to show the infrequent narrow pulse. In this case you would need to select the **Normal** trigger mode so that the scope would wait until obtaining a valid trigger event before displaying waveforms. We will connect to such a signal a bit later during Lab #8 and Lab #9. But for now, let’s learn more about triggering on noisy signals.

Lab #3: Triggering on Noisy Signals

A repetitive sine wave is about the simplest type of signal for a scope to trigger on. But in the real world, signals are not so simple. In this lab we will learn how to trigger on signals in a noisy environment (a real-world condition), as well as learn how to eliminate noise on digitized waveforms using waveform averaging.

- 1 Ensure that your two oscilloscope probes are still connected between the terminals labeled Demo1 & Demo2 and the Channel-1 & Channel-2 input BNCs respectively.
- 2 Press **[Default Setup]** on the scope's front panel.
- 3 Press **[Help]**; then tap the **Training Signals** softkey.
- 4 Using the **Training Signals** menu, double tap the **"Sine with Noise"** signal.
- 5 Set channel-1's V/div to **500 mV/div**.
- 6 Set the scope's timebase to **200.0 μ s/div**.

Even though the scope's default setup condition configures the scope to trigger on rising edges at 0.0 V, it appears that the scope is triggering on both rising and falling edges of this noisy sine wave as shown in [Figure 16](#). The scope is actually triggering **ONLY** on rising edges. However, when the scope appears to be triggering on a falling edge of the sine wave, it is actually triggering on a rising edge of the random noise that is riding on the sine wave.

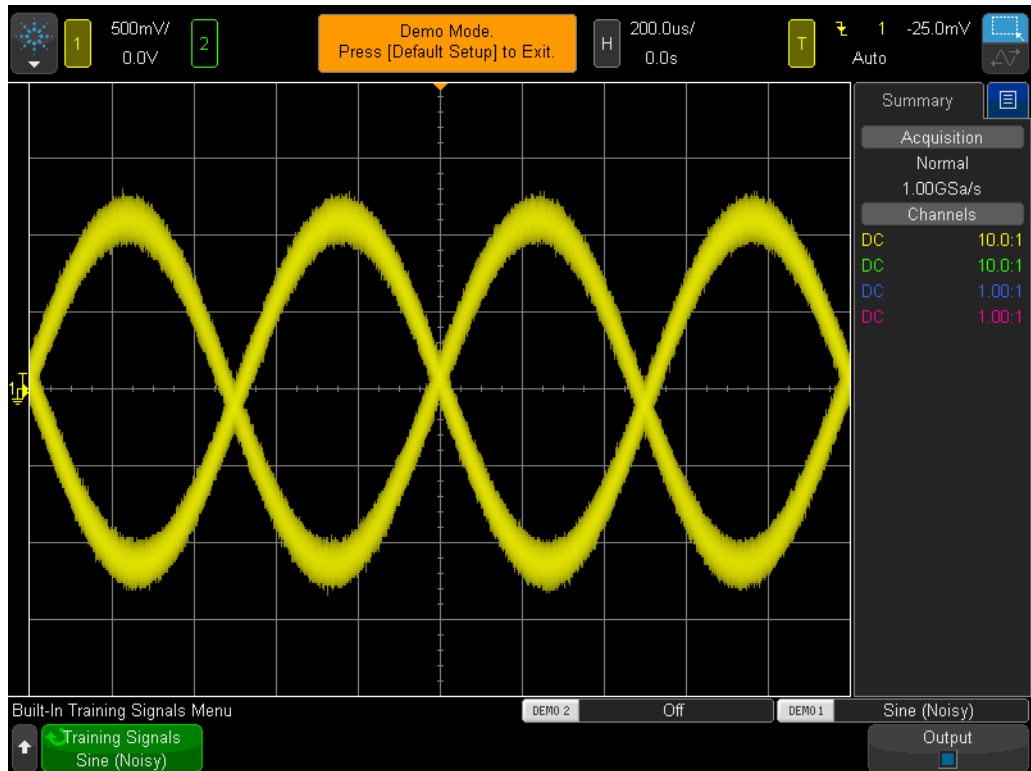

Figure 16 Attempting to trigger on signals in a noisy environment

- 7 Verify that the scope is triggering on rising edges of noise by setting the timebase to **200.0 ns/div**.
- 8 Set the scope’s timebase back to **200.0 μs/div**.

So how can we make the scope trigger during instances that are only coincident with the rising edge of the sine wave (without noise)? Let’s now learn more about some of the scope’s user-selectable trigger coupling options.

- 9 Press the **[Mode/Coupling]** front panel key (near the trigger level knob).
- 10 Tap the **HF Reject** softkey to turn on a “high frequency reject” filter.

The input signal to the scope is actually split and sent down two different analog paths inside the scope. The signal going down one path is captured by the scope’s acquisition system (picture taking system). A similar signal is sent down a separate path to be processed by the scope’s analog trigger circuitry. (Refer to the oscilloscope block diagram shown in Appendix A.) When **HF Reject** has been selected, the signal that is processed by the scope’s analog trigger circuitry is first passed through a 50 kHz low-pass filter. Since the noise consists of a broad spectrum of frequencies, including high frequency elements, the trigger circuitry then “sees” a sine wave with most of the noise removed/attenuated, while the signal that is

sent down the acquisition path is unaffected (noise retained). This way we see the noise, as shown in [Figure 17](#), but the scope's trigger circuitry does not see the noise. But there are limitations.

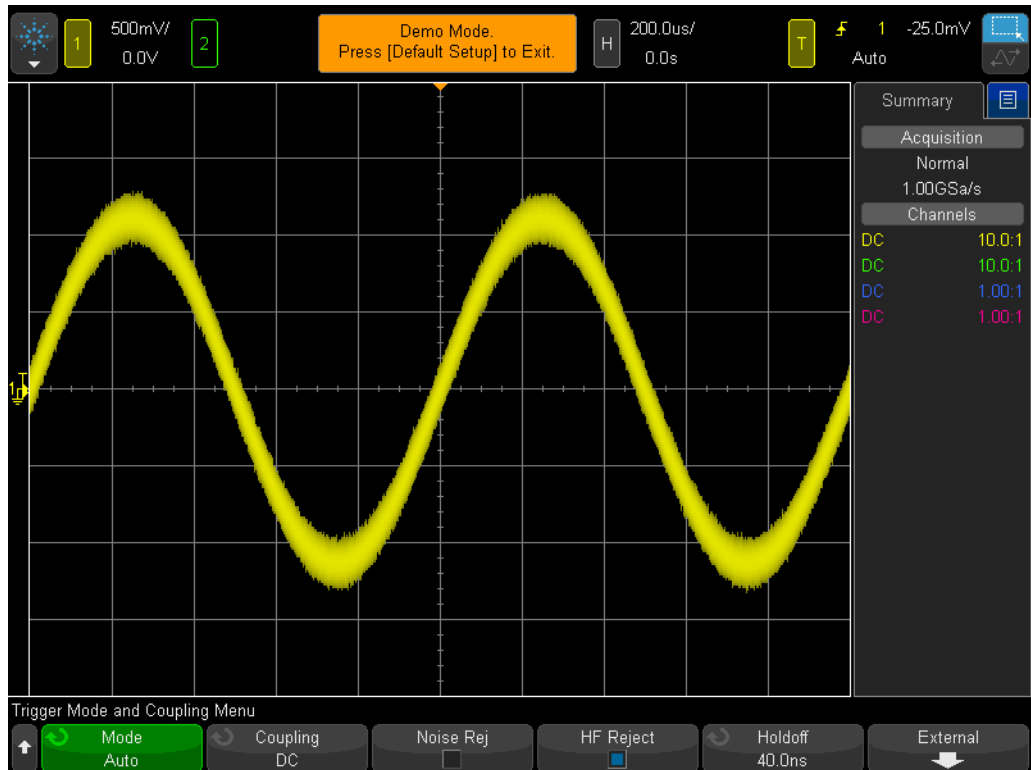

Figure 17 Triggering on a noisy sine wave using HF Reject

Since the **HF Reject** filter is based on a fixed 50 kHz low-pass hardware filter, it can't be used on higher frequency signals. This 50 kHz low-pass filter does not affect our 1 kHz sine wave training signal. But if we were attempting to use trigger **HF Reject** on a noisy 20 MHz sine wave, the 50 kHz filter would “kill” both the noise and the fundamental 20 MHz sine wave making it impossible to trigger on anything. But we have two more options.

11 Tap the **HF Reject** softkey again to turn it off. The scope should appear to trigger on the rising and falling edges of the sine wave again.

12 Tap the **Noise Rej** softkey to turn on the “noise reject” filter.

The **Noise Rej** filter is not based on frequency, but is based on amplitude. Although we have been talking about a single trigger level, there are actually two levels that a signal must cross through in order to qualify as a valid trigger. This is called “trigger hysteresis”, or sometimes referred to as “trigger sensitivity”. The default trigger sensitivity of most scopes is 0.5 divisions. This means that input signals must swing at least 0.5 divisions

peak-to-peak in order to qualify as valid trigger conditions. But this also means that scopes will trigger on noise if the noise exceeds approximately 0.5 divisions peak-to-peak. When **Noise Rej** is selected, the scope's hysteresis is expanded to approximately 1.0 division peak-to-peak. For this particular noisy sine wave, 1.0 divisions of trigger hysteresis solves our problem most of the time. You may notice some "flickering" on the scope's display. This means that the 1.0 divisions of hysteresis is not quite enough. Another solution is to use the scope's trigger holdoff feature, which we will talk about during lab #7.

Before we depart from making measurements on this sine wave with noise, what if we wanted to view and perform measurements on this sine wave, but without the random noise?

- 13 Tap the **HF Reject** softkey. Now both high frequency reject filtering, as well as noise reject filtering should be turned on to provide us with a very stable trigger.
- 14 Press the [**Acquire**] key in the Waveform section of the front panel.
- 15 Tap the **Acq Mode** menu to change the scope's acquisition mode from **Normal** to **Averaging**.

When the **Averaging** acquisition mode has been selected, the scope averages multiple waveform acquisitions together. If the noise riding on the signal is random, then the noise component will average out so that we can then make more accurate measurements on just the fundamental signal component as shown in [Figure 18](#).

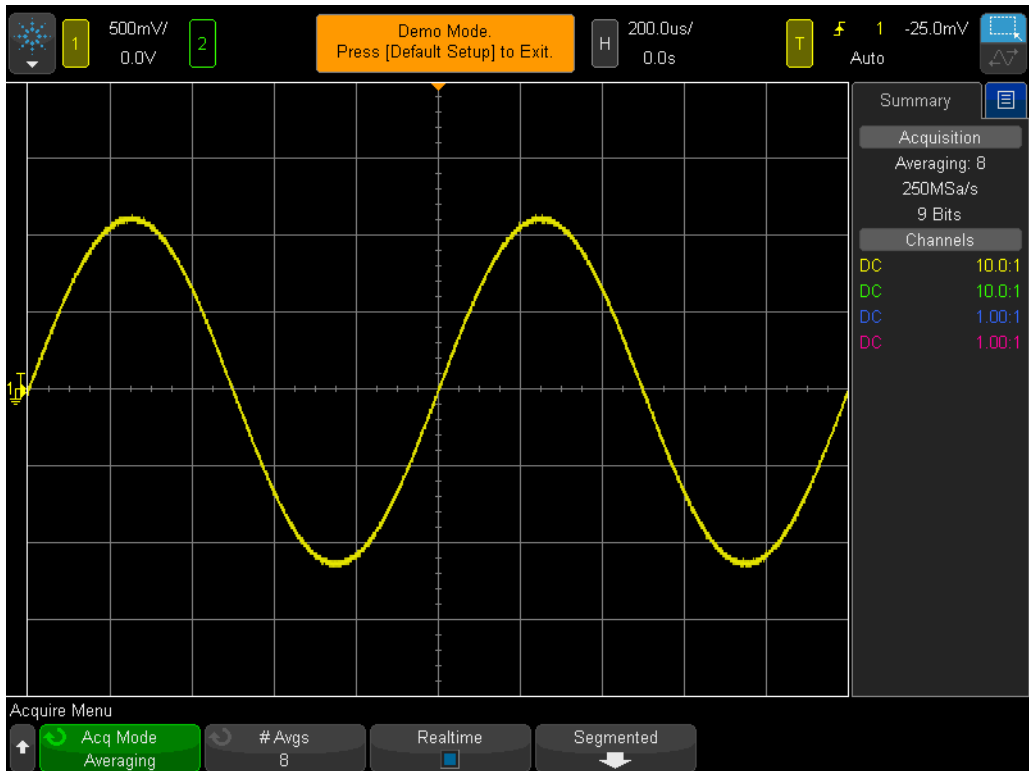

Figure 18 Using the scope’s Averaging acquisition mode to eliminate the noise

16 Using the measurement techniques you learned in Lab #1, determine the following:

Period = _____

Freq = _____

Vp-p = _____

Lab #4: Documenting and Saving Oscilloscope Test Results

When you complete your various circuits lab assignments, your professor may require you to write up a test report. Including images (pictures) of your measurements in your lab report may be required. In addition, if you can't complete a lab assignment during one session, you may want to continue testing at a later time. But it would really be great if you could pick up where you left off; without having to re-setup your scope or possibly re-acquire waveforms. In this lab you will learn how to save and recall various oscilloscope file types including images, reference waveforms, and setups. For this lab you must have access to a personal USB memory device.

- 1 Ensure that your two oscilloscope probes are still connected between the terminals labeled Demo1 & Demo2 and Channel-1 & Channel-2 input BNCs respectively.
- 2 Press [**Default Setup**] on the scope's front panel.
- 3 Press [**Help**]; then tap the **Training Signals** softkey.
- 4 Using **Training Signals** menu, select the "**Sine**" waveform.
- 5 Set channel-1's V/div to **500 mV/div**.
- 6 Set the scope's timebase to **100 ns/div**.

At this point you should see five cycles of a sine wave as shown in [Figure 19](#). Let's now save this image (picture), save the waveform, and save the setup.

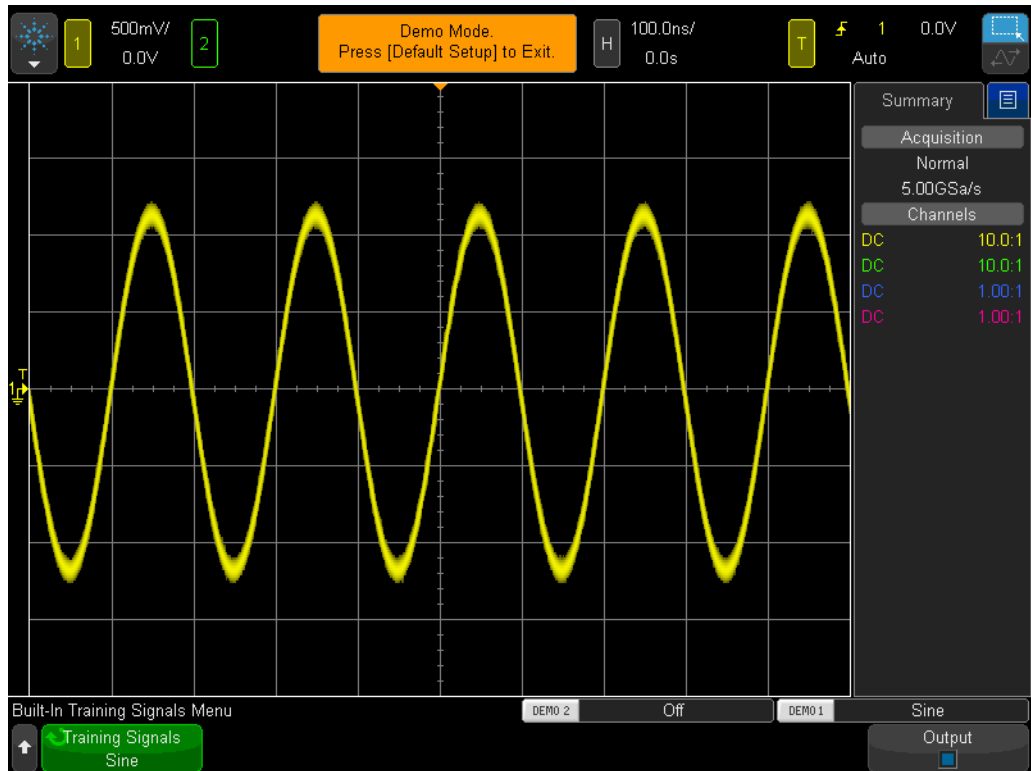

Figure 19 Five cycles of a sine wave that we want to save for documentation and later analysis

- 7 Insert your personal USB memory device into the scope's front panel USB port.
- 8 Press the **[Save/Recall]** key in the File section of the front panel below the Cursors knob.
- 9 Tap the **Save** softkey; then tap the **Format** softkey.
- 10 Using the **Format** menu, select **PNG 24-bit image (*.png)**.
- 11 Tap the **Save to** softkey; then select **\usb**.
- 12 Tap the **File Name** softkey; tap it once more to open the keyboard to give this file a name.
- 13 Use the Clear button on the keyboard to wipe the current name.
- 14 For now, let's call it "test". Tap Enter when finished.
- 15 Tap the **Increment** softkey to turn off auto-increment (box should be black).

Note that if auto-increment is turned on, the scope will automatically increment a number associated with the file name. This can be useful if you intend to save multiple images without needing to manually re-enter different file names between each save operation.

16 Tap the **Press to Save** softkey.

Your USB memory device should now have a stored image of the scope's display similar to [Figure 19](#). The file name should be "test.png". You can open this file or insert it into a word processing document later to see if it is really there. Let's now save the scope's setup configuration.

17 Press the [**Save/Recall**] front panel key.

18 Tap the **Save** softkey; then tap the **Format** softkey.

19 From the list, select **Setup (*.scp)**.

20 Tap the **Location** softkey.

21 Point to `\usb` with a touch of your finger.

22 Tap the **File Name** softkey. You will see that the previous file name you entered will become the new default file name. Since the "setup" file format uses a different file name extension, we can use the same file name.

23 Tap the **Press to Save** softkey.

Your USB memory device should now have the file named "test.scp" that contains the scope's current setup configuration. We will recall this setup configuration later. Note that you can also save setups to one of the scope's internal flash memory registers. However, one of your fellow students that may use this oscilloscope next could overwrite this memory register with his/her setup. So it is always good practice as a student using a shared scope to save oscilloscope setups and waveforms using your own personal memory device. Let's now save a reference waveform data file.

24 Press the [**Save/Recall**] front panel key.

25 Tap the **Save** softkey; then tap the **Format** softkey.

26 Using the **Format** menu, select **Reference Waveform data file (*.h5)**.

27 Tap the **Save to** softkey.

28 Point to `\usb` with the touch of your finger.

29 Tap the **File Name** softkey. Again, we don't need to define a new name since this file format will also have a unique file name extension (test.h5).

30 Tap the **Press to Save** softkey.

Note that when we saved the .png file type earlier, this was just a pixel map of the scope's display. This type of file cannot be recalled back into the scope, and measurements cannot be performed on data stored in this type of file. This type of file, as well as a .bmp file type, is primarily useful for documentation purposes, such as inclusion in your lab reports. But the "Reference Waveform" data file (.h5) that we just stored saves

voltage versus time data as X-Y pairs. This type of file can be recalled back into the scope for later analysis. You can also recall this type of file into many PC applications for more extensive off-line analysis.

Now that we have saved the scope's setup configuration, as well as saved the waveform (5 cycles of a sine wave), let's see if we can recall these files. But first we will begin with a default setup in order to destroy the current setup and waveform that you see on-screen.

31 Press [**Default Setup**].

32 Press [**Save/Recall**].

33 Tap the **Recall** softkey; then tap the next **Recall** softkey.

34 Select **Setup** as the type of file to recall using the **Recall** menu.

35 Tap the **Press to go** softkey; then select "test" with your finger.

36 Tap the **Press to Recall** softkey.

We should have just restored the scope's setup to its previous configuration.

However, the scope does NOT save the status of the training signals. So at this point the only waveform we should see is a baseline (0.0 V) signal since there are no signals present at the inputs of our probes. Let's now recall the waveform that we previously saved.

37 Open the **Recall** softkey menu; then select **Reference Waveform data (*.h5)**.

38 Tap the **Press to go** softkey; then select to "test".

39 Tap the **Press to Recall** softkey.

You should now see the live waveform and the stored version of our sine wave using the previous setup configuration as shown in [Figure 20](#). At this point you can change the setup if you like, and you can also continue making measurements on this stored waveform. Note that you can remove your USB memory device at any time after saving/recalling your data.

2 Basic Oscilloscope and WaveGen Measurement Labs

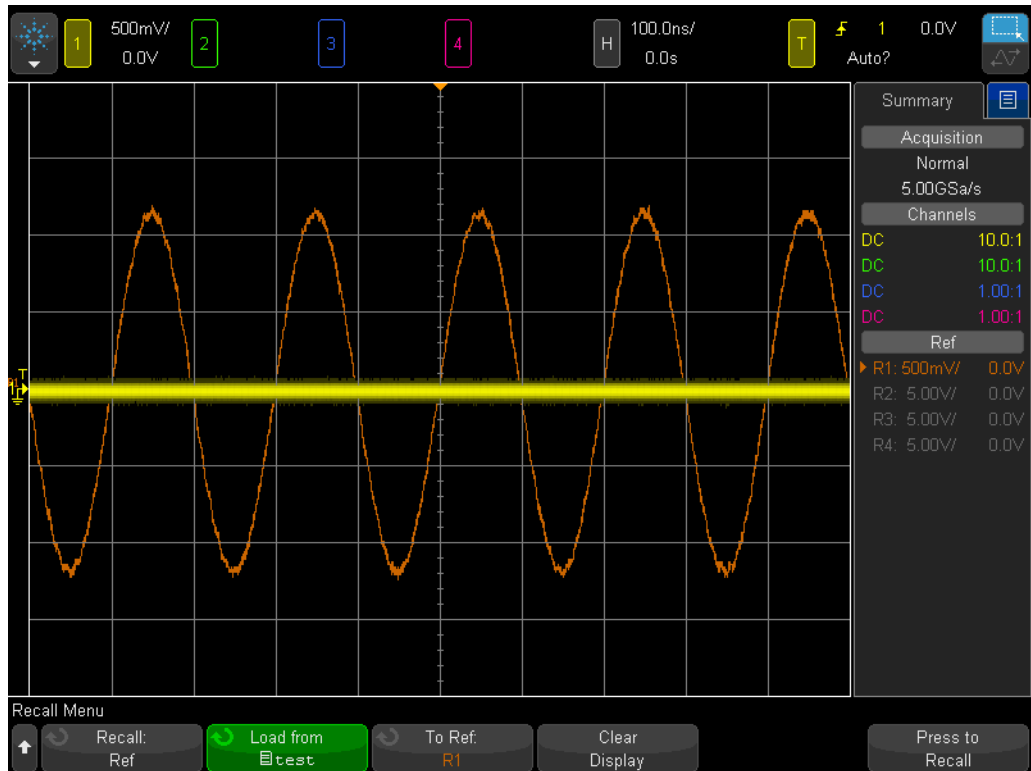

Figure 20 Recalling the scope's setup configuration and waveform

Lab #5: Compensating your Passive 10:1 Probes

Now that you've completed the first four labs in this oscilloscope training guide and should be somewhat familiar with how to use an oscilloscope to make basic voltage and timing measurements, let's take a step back and talk about probing again. In the [Getting Started](#) section of this guide we briefly discussed probing and showed the electrical input model of the combination of a passive 10:1 probe and the oscilloscope's input. This electrical model of the probe and oscilloscope is shown again here in [Figure 21](#).

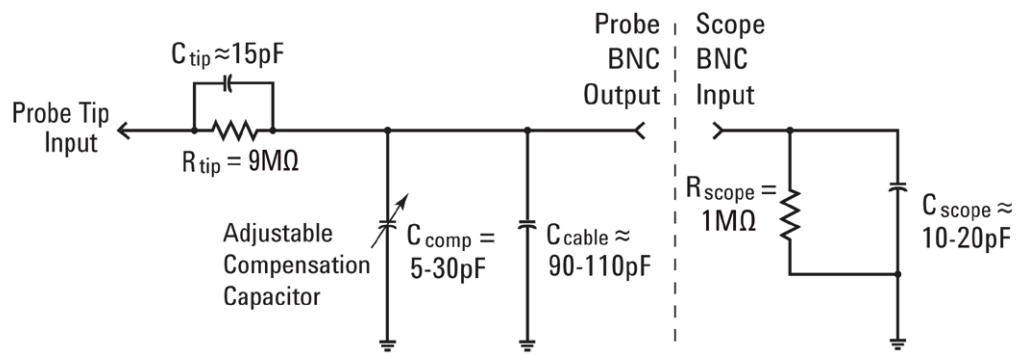

Figure 21 Simplified schematic of a passive 10:1 probe connected to the scope's 1 M Ω input impedance

If you remember, you were instructed to ignore the capacitive components in this electrical model and consider just the resistive components. When we looked at just the resistive components, we determined that the combination of the probe's 9 M Ω probe tip resistor plus the scope's 1 M Ω input impedance established a 10-to-1 voltage-divider ratio. For low-frequency or dc applications, ignoring the capacitive elements is appropriate. But if you need to measure dynamic signals, which is the primary measurement application for oscilloscopes, the capacitive elements of this electrical model can't be ignored.

Inherent in all oscilloscope probes and scope inputs are parasitic capacitances. These include the probe cable capacitance (C_{cable}), as well as the scope's input capacitance (C_{scope}). "Inherent/parasitic" simply means that these elements of the electrical model are not intentionally designed-in; but are just an unfortunate fact of life in the real world of electronics. And the amount of inherent/parasitic capacitance will vary from scope-to-scope and probe-to-probe. But without additional designed-in capacitive components to compensate for the inherent capacitive elements in the system, the reactance of the system under dynamic signal conditions (non-dc) can change the overall dynamic

attenuation of the probing system to something different than the desired 10:1 ratio. The purpose of the additional/designed-in probe tip capacitor (C_{tip}) along the adjustable compensation capacitor (C_{comp}) is to establish a capacitive reactance attenuation that matches the resistive attenuation of 10:1. When the compensation capacitor is properly adjusted, this also ensures that the time constant of the probe tip capacitance in parallel with the 9 M Ω resistor matches the time constant of the inherent and compensation capacitances in parallel with the scope's 1 M Ω input resistor.

Rather than spending a lot more time talking about the theory of this, let's just connect to a signal and see the effect of under-compensation, over-compensation, and proper-compensation. But first be aware that we will be connecting our channel-1 probe to a different terminal from the previous labs.

- 1 Connect **both** of your oscilloscope probes to the terminal labeled **Probe Comp**. Note that this is the same terminal that is also labeled **Demo2**.
- 2 Press [**Default Setup**] on the scope's front panel.
- 3 Set channel-1 to **1.0 V/div**.
- 4 Set channel-1 offset/position to **0.0 V** (default setting).
- 5 Press the trigger level knob to set the trigger level to approximately **50%** on channel-1.
- 6 Press the [**2**] front panel key to turn on channel-2.
- 7 Set channel-2 to **1.0 V/div**.
- 8 Set channel-2 offset/position to approximately **+3.5 V**.
- 9 Set the scope's timebase to **200.0 $\mu\text{s}/\text{div}$** .

If your probes are properly compensated, you should see two 1 kHz square waves with a very flat response on your scope's display similar to [Figure 22](#). Let's now adjust the probe compensation on each probe.

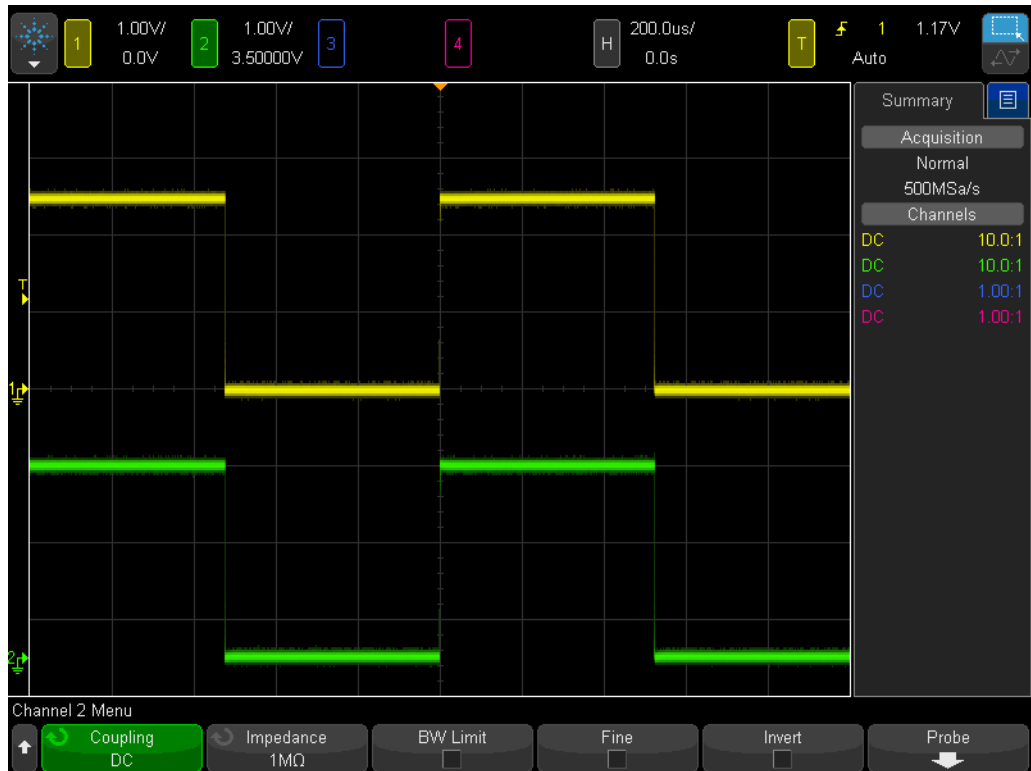

Figure 22 Using the scope's 1 kHz probe compensation signal to compensate 10:1 passive probes

- 10 Using a small flathead screw driver, adjust the variable capacitor located on the body of each probe. Note that this adjustment is sometimes located near the BNC connection end of some probes.

Figure 23 shows an example of the channel-1 probe (yellow waveform) over-compensated, and an example of the channel-2 probe (green waveform) under-compensated. If you don't observe a near-perfect square wave, then re-adjust the probe compensation on your probes until the waveforms on your scope are similar to Figure 22.

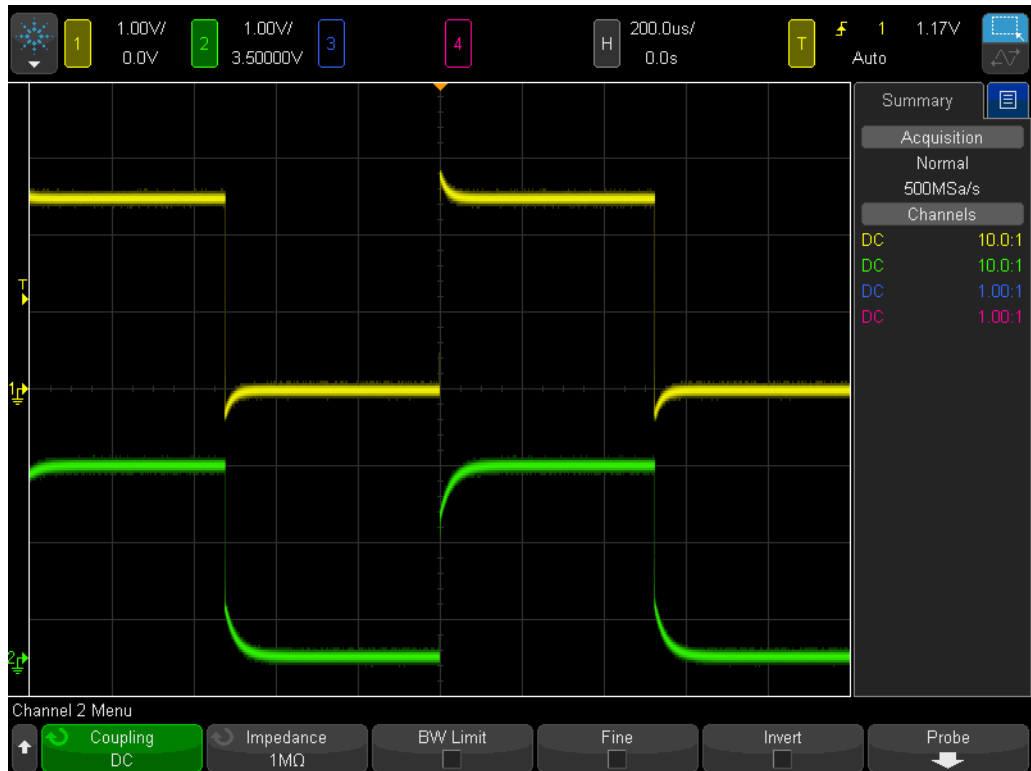

Figure 23 Improperly compensated probes

After your probes have been properly adjusted, so long as you continue to use these probes on this scope, you shouldn't need to re-adjust them the next time you use the scope.

At this point you have completed the hands-on portion of this lab. If you are running short on time and need to complete the last lab in this chapter, then skip to Lab #6 and then read the content of the remainder of this lab later.

Computing the Proper Amount of Capacitive Compensation

If you are up for a challenge, compute the amount of compensation capacitance (C_{comp}) required for proper compensation using the following assumptions:

- $R_{tip} = 9 \text{ M}\Omega$
- $R_{scope} = 1 \text{ M}\Omega$
- $C_{scope} = 15 \text{ pF}$
- $C_{cable} = 100 \text{ pF}$
- $C_{tip} = 15 \text{ pF}$

$$C_{\text{parallel}} = C_{\text{scope}} + C_{\text{cable}} + C_{\text{comp}}$$

$$C_{\text{comp}} = ?$$

To compute the required amount of compensation capacitance (C_{comp}), the easiest method is to equate the time constant ($1/RC$) of the parallel combination of R_{tip} and C_{tip} with the time constant of the parallel combination of R_{scope} and C_{parallel} :

$$\frac{1}{R_{\text{tip}} \times C_{\text{tip}}} = \frac{1}{R_{\text{scope}} \times C_{\text{parallel}}}$$

Remember that C_{parallel} is the combination of three capacitive elements in the probe/scope model.

Another computational method would be to equate 9X the capacitive reactance of C_{parallel} with 1X the capacitance reactance of C_{tip} . This will establish the same attenuation factor contributed by capacitive reactances as the attenuation factor contributed by the resistive-only network (10:1):

$$\frac{1}{2\pi f C_{\text{tip}}} = 9 \times \frac{1}{2\pi f C_{\text{parallel}}}$$

$$C_{\text{comp}} = \underline{\hspace{2cm}}$$

Probe Loading

Besides properly compensating your 10:1 passive probes in order to achieve the most accurate oscilloscope measurements, another issue that must be considered is probe loading. In other words, will connecting the probe and scope to your device-under-test (DUT) change your circuit's behavior? When you connect any instrument to your circuit, the instrument itself becomes a part of your DUT and can "load" or change the behavior of your signals to some degree. If we use the given values of resistances and capacitances listed above (along with the value of C_{comp} that you computed), we can model the loading affect of the probe and scope together as the parallel combination of a single resistor and capacitor as shown in [Figure 24](#).

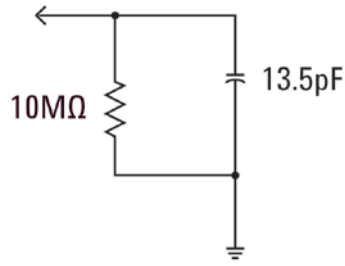

Figure 24 10:1 passive probe and scope loading model

For low frequency or dc applications, loading is dominated by the 10 MΩ resistance, which in most cases should not be a problem. But what if you are probing a 100 MHz digital clock signal? The 5th harmonic of this digital clock, which is a significant component in creating the shape of this signal, would be 500 MHz. Now compute the reactance contributed by the 13.5 pF capacitance of this loading model shown in [Figure 24](#):

$$X_c = \frac{1}{2\pi fC} = \frac{1}{2\pi \times 500 \times 10^6 \times 13.5 \times 10^{-12}} = 23.6\Omega$$

Although 13.5 pF may not sound like much, at higher frequencies this amount of loading capacitance can be significant. For higher frequency applications such as this, most scope vendors provide optional active probing solutions that have significantly lower input capacitances (sub pF). But these types of special probes cost significantly more than the typical 10:1 passive probe.

Lastly, be aware that the probe + scope models presented in this lab are very simplified. More accurate models would include inductive elements as well. Wire, especially your ground lead, should be considered as an inductive element, especially for high frequency applications.

Lab #6: Using the WaveGen built-in Function Generator

Besides oscilloscopes, you will be using a broad range of test equipment in your various EE and/or Physics circuits labs including power supplies, digital multimeters, and function generators. Function generators can produce a broad range of different types/shapes of signals that you will use as dynamic inputs to your circuit designs and experiments. Agilent's InfiniiVision 4000 X-Series oscilloscopes have a built-in optional function generator called WaveGen. Completing this short lab requires that your university has purchased this option on the oscilloscope that you are using. If you don't know if the function generator capability has been licensed and enabled, press the **[Wave Gen]** front panel key. If this option is enabled, the WaveGen's menu will appear. If this option is not enabled, then you will see a message on-screen indicating that this option has not yet been licensed. Assuming that your scope has the WaveGen option, let's begin this short lab to learn how to use a general-purpose function generator.

- 1 Disconnect all probes from the oscilloscope.
- 2 Connect a coaxial 50 Ω BNC cable between the generator's output #1 (next to the power switch) and the channel-1 input BNC.
- 3 Press **[Default Setup]**.
- 4 Press the **[WaveGen1]** front panel key (just above the channel-3 V/div knob).
- 5 Tap the **Settings** softkey; then tap the **Default Wave Gen** softkey.

Note that the scope's **[Default Setup]** does NOT change the WaveGen's settings. So to ensure that we are all beginning from the same starting point, we need to also default the generator's settings.

- 6 Press the **[WaveGen]** front panel key again.
- 7 Set channel-1's V/div setting to **100 mV/div**.
- 8 Set the scope's timebase to **100.0 μ s/div** (default setting).

You should now see one cycle of a sine wave on your oscilloscope similar to [Figure 25](#). A 1.000 kHz sine wave with a peak-to-peak amplitude of 500 mV is the WaveGen's default signal. Let's now make some changes to the signal.

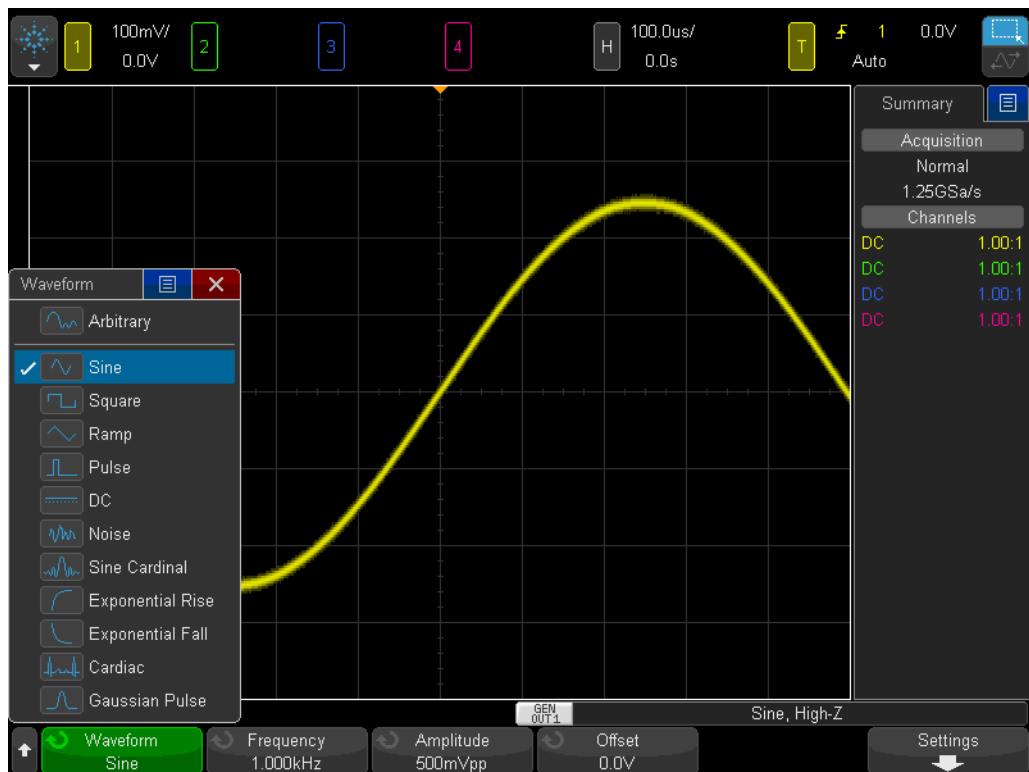
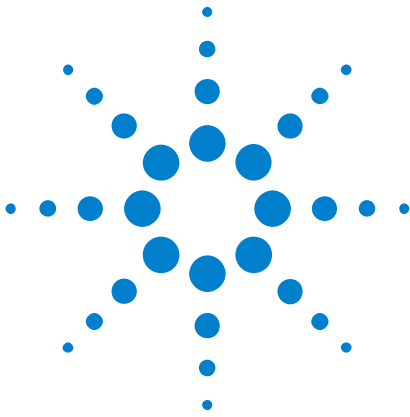

Figure 25 Using the scope's built-in WaveGen function generator

- 9 Tap the **Frequency** softkey; then rotate the **Entry** knob to increase or decrease the frequency. Alternatively, tap **Frequency** once more in the pop up box to explicitly set the frequency with the keypad. Note that the maximum frequency setting is 20.00 MHz.
- 10 Tap the **Amplitude** softkey; then rotate the **Entry** knob to change the amplitude of this signal. Alternatively, tap **Amplitude** once more in the pop up box to explicitly set the amplitude with the keypad. Note that the maximum amplitude setting is 10 Vp-p.
- 11 Tap the **Offset** softkey; then rotate the **Entry** knob to change the offset of this signal. Alternatively, tap **Offset** once more in the pop up box to explicitly set the offset with the keypad.
- 12 Tap the **Waveform** menu to select various waveforms.

Note that when **Square** has been selected, you can also tune the **Duty Cycle**. And when **Pulse** has been selected, you can tune the pulse width. From this point on, you probably won't be connecting the generator's output directly into the scope. You will probably be connecting the output of the generator to the input of your circuits. And then you would use the scope with probes to monitor both the input and outputs of your circuits. That's all there is to it!



3 Advanced Oscilloscope Measurement Labs

- Lab #7: Triggering on a Digital Burst using Trigger Holdoff 48
- Lab #8: Triggering on, Capturing, and Analyzing an Infrequent Event 52
- Lab #9: Capturing a Single-shot Event 56
- Lab #10: Performing Automatic Parametric Measurements on Digital Waveforms 59
- Lab #11: Using the Scope's Zoom Timebase to Perform Gated Measurements 65
- Lab #12: Phase Delay Measurements and Lissajous Waveforms 70
- Lab #13: Using Oscilloscope Waveform Math 74
- Lab #14: Using Peak Detect to Overcome Under-sampling 78
- Lab #15: Using Segmented Memory to Capture More Waveforms 82



Lab #7: Triggering on a Digital Burst using Trigger Holdoff

Signals in the real world of electronics are rarely as simple as repetitive sine waves and square waves. Establishing unique trigger points (synchronized picture taking) on more complex signals sometimes requires using trigger “hold-off”. In this lab you will learn how to use the scope’s trigger hold-off capability in order to trigger on a burst of digital pulses.

- 1 Connect one oscilloscope probe between the channel-1 input BNC and the output terminal labeled “Demo1”. Connect this probe’s ground clip to the center terminal (ground).
- 2 Connect a second oscilloscope probe between the channel-2 input BNC and the output terminal labeled “Demo2”. Connect this probe’s ground clip to the center terminal.
- 3 Press [**Default Setup**] on the scope’s front panel.
- 4 Press [**Help**]; then tap the **Training Signals** softkey.
- 5 Using the **Training Signals** menu, select the “**Digital Burst**” signal; then tap **Output** to turn it on.
- 6 Set channel-1’s V/div setting to **1.00 V/div**.
- 7 Set channel-1’s offset/position to approximately **+1.7 V** in order to center this waveform on the scope’s display.
- 8 Press the Trigger Level knob to automatically set the trigger level to approximately **50%**.
- 9 Set the scope’s timebase to **20.00 μ s/div**.

You should see on your scope’s display what may appear to be an un-triggered display of a series of digital pulses similar to [Figure 26](#). The scope is actually triggering on random rising edge crossings of this complex digital data stream, which is actually a “burst” of pulses. Unfortunately we can’t “see” the burst activity because we haven’t yet setup the scope to establish a unique trigger point on this complex signal. So let’s now “stop” repetitive acquisitions so that we can see a single-shot acquisition of the bursts, and then make some measurements. We will then use these measurements to enter a specific trigger holdoff time in order to synchronize triggering on the 1st pulse of each burst.

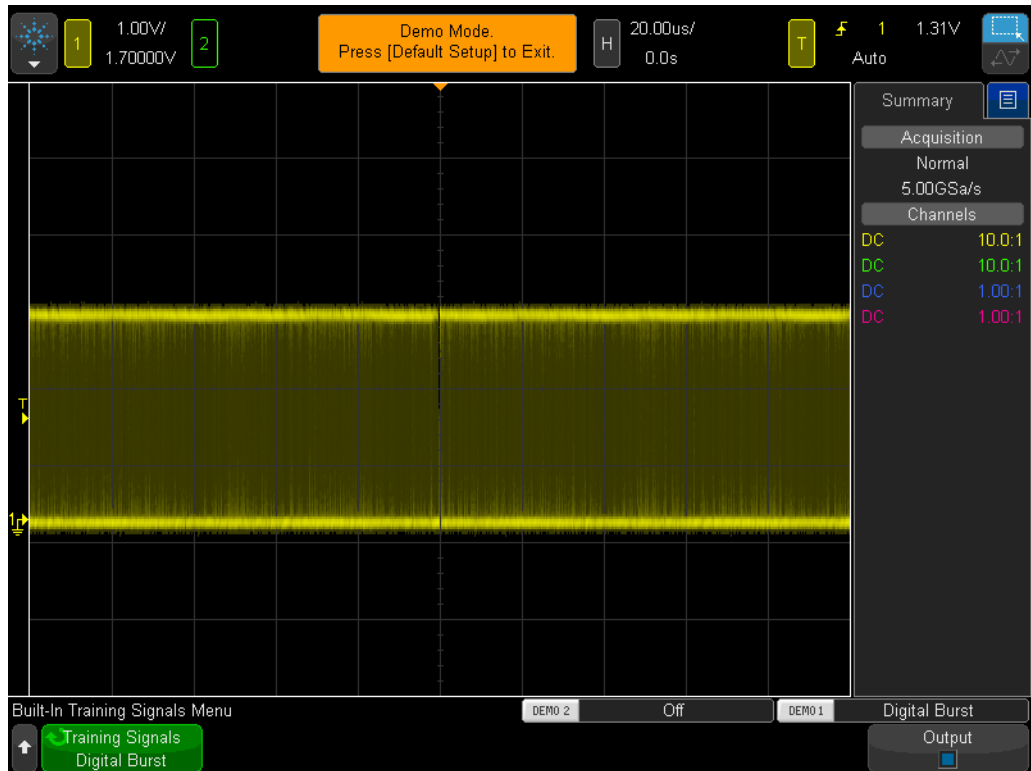

Figure 26 Attempting to view a burst of pulses while using the scope's default trigger setup conditions

10 Press the **[Run/Stop]** front panel key to stop repetitive acquisitions.

With repetitive acquisitions stopped, you should now be able to see digital burst activity as shown in [Figure 27](#). In other words, there are a series of negative pulses followed by a short signal dead-time (high level), and then it repeats. If you press **[Single]** several times, you should observe that the trigger event (rising edge closest to center-screen) for each acquisition is almost always a different pulse within the burst.

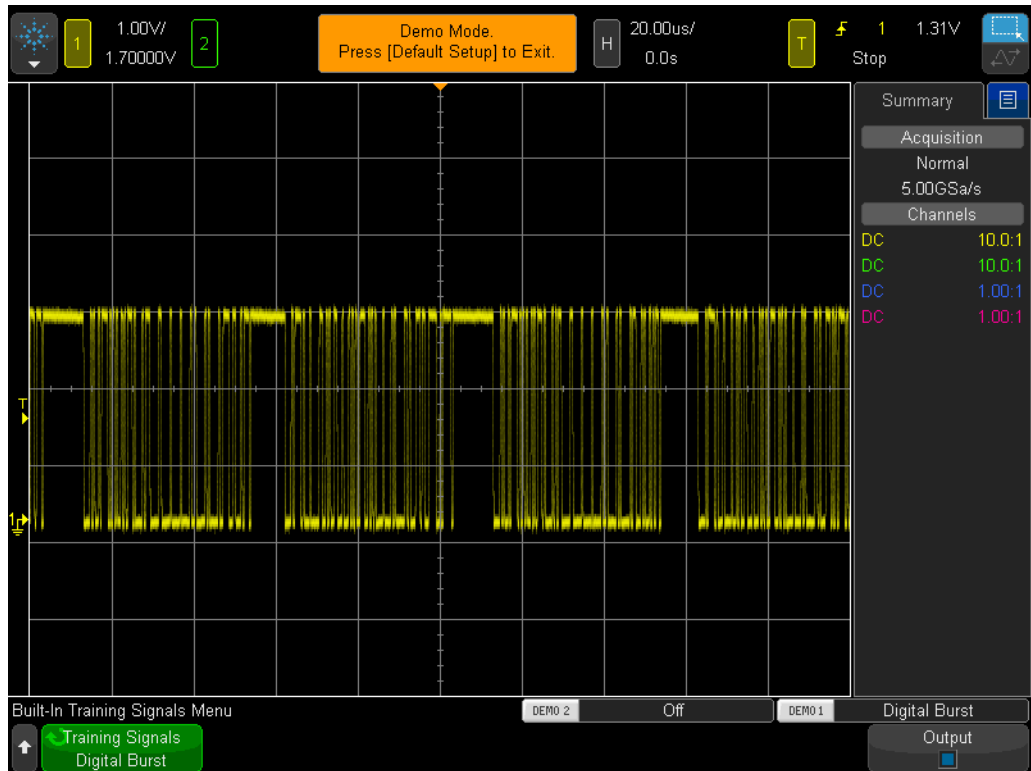

Figure 27 Random edge triggering on a digital burst input signal

Using what you learned during Lab #1, either estimate or use the scope’s timing cursors (X1 & X2) to measure the width of one of the burst of pulses, and also measure the time from the beginning of one burst of pulses to the beginning of the next burst of pulses. You should find that the width of each burst is approximately 40 μs , and the time from burst-to-burst is approximately 50 μs .

When we use the scope’s default triggering condition, the scope triggers on “any” random edge of this signal. In other words, sometimes the scope triggers on the 1st edge of the burst, sometimes the 11th edge of the burst, sometimes the 5th edge, etc. An ideal synchronization point would be to setup the scope so that it always triggers on just the 1st edge of each burst, rather than a random edge. We can do this using the scope’s “trigger holdoff” capability.

With trigger holdoff, we can instruct the scope to always arm triggering during the signal dead-time between each burst of pulses. This way the scope will always trigger on the next rising edge after arming, which will always be the 1st edge of each burst. An ideal holdoff time to achieve this would be a trigger holdoff time somewhere between 40 μs (width of burst) and 50 μs (time from burst-to-burst). This may sound confusing, so let’s just do it and see what happens.

- 11 Press the **[Run/Stop]** front panel key to begin repetitive acquisitions again.
- 12 Press the **[Mode/Coupling]** key in the Trigger section of the front panel.
- 13 Tap the **Holdoff** softkey; then use the keypad to set a holdoff value of **45.000 μ s**.

You should now see a synchronized display as shown in **Figure 28**. This figure shows X1 set at the trigger point, and X2 set 45 μ s ahead, which represents the holdoff time. The scope triggers on the 1st rising edge of a burst of pulses (center-screen) and then disables triggering for 45.00 μ s (holdoff time). During this holdoff time, the scope ignores the 2nd, 3rd, 4th, etc., crossings, and then re-arms triggering after the end of the burst, but before the beginning of the next burst, which is during the signal's “dead-time”. The next valid trigger event will again be the 1st rising edge crossing on the next burst.

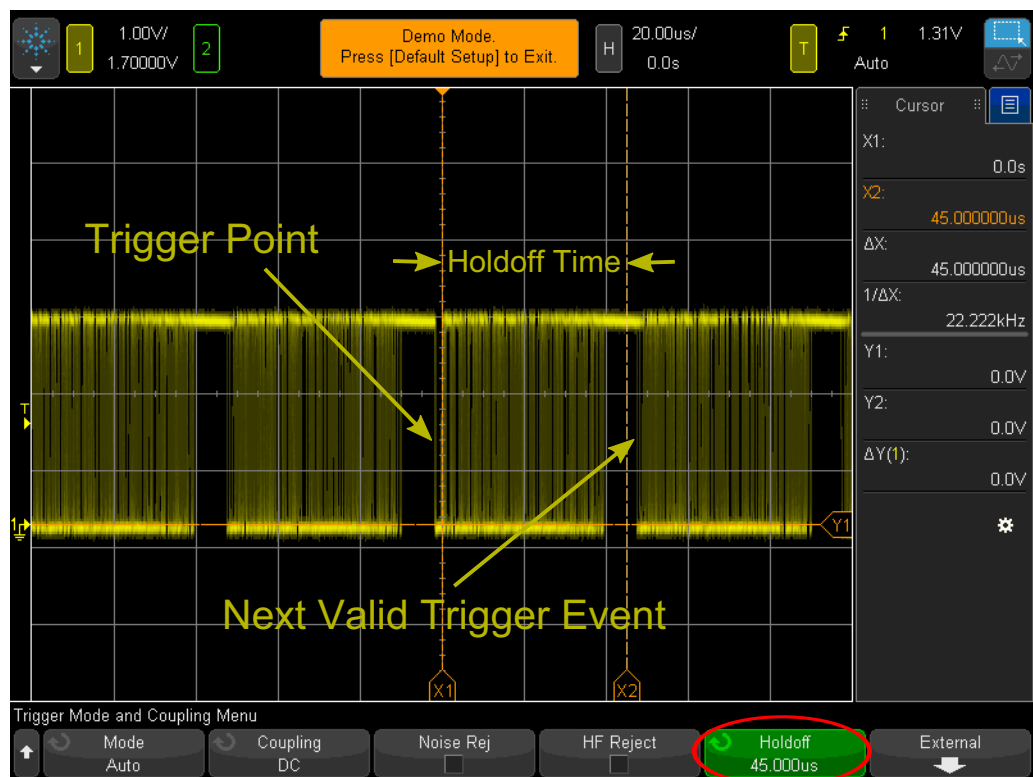

Figure 28 Using the scope’s trigger holdoff capability to synchronize on a burst of pulses

Lab #8: Triggering on, Capturing, and Analyzing an Infrequent Event

In this lab you will learn how to use some of the scope's various persistence display modes to enhance the display of an infrequently occurring glitch. In addition, you will learn how to use the scope's Pulse Width triggering mode to trigger on the glitch.

- 1 Ensure that your two oscilloscope probes are still connected between the terminals labeled Demo1 & Demo2 and the Channel-1 & Channel-2 input BNCs respectively.
- 2 Press [**Default Setup**] on the scope's front panel.
- 3 Press [**Help**]; then tap the **Training Signals** softkey.
- 4 Using the **Training Signals** menu, select the "**Clock with Infrequent Glitch**" signal; then select it twice or tap the **Output** softkey to turn it on.
- 5 Set channel-1's V/div setting to **500 mV/div**.
- 6 Set channel-1's position/offset to **1.00 V** in order to center the waveform on-screen.
- 7 Press the trigger level knob in order to automatically set the trigger level at approximately **50%** (~1.0 V).
- 8 Set the scope's timebase to **20.00 ns/div**.

At this point you may notice an infrequent and dim "flicker" near center-screen. This is an infrequently occurring glitch (or narrow pulse) that the scope is capturing. Although the scope usually triggers on a rising edge of the clock signal, it occasionally triggers on a rising edge of this infrequent glitch. The reason this glitch appears dim is because the scope displays frequently occurring signals brightly, while displaying infrequently occurring signals dimly. This gives us a clue that this glitch does not occur very often.

- 9 Press the small [**Intensity**] button (located below the **Entry** knob); then turn the **Entry** knob clockwise until the intensity is adjusted to **100%**.

With the waveform intensity adjusted to 100%, the scope displays all captured waveforms at the same bright intensity, and we can now clearly see this infrequently occurring glitch as shown in [Figure 29](#). Capturing an infrequent event such as this while triggering on any edge crossing (default trigger type) requires using a scope that has a very fast waveform update rate (fast picture taking). Let's now explore some of the scope's special display modes that can further enhance our ability to see this glitch.

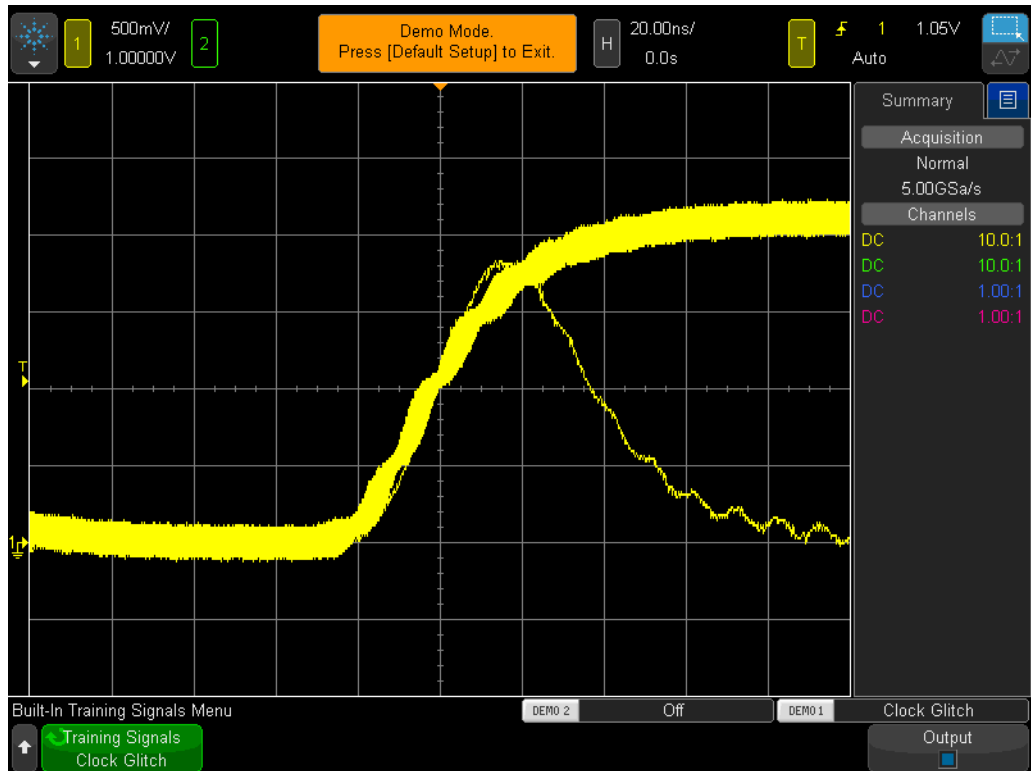

Figure 29 The scope's fast waveform update rate captures an infrequently occurring glitch

- 10 Press the **[Display]** front panel key (below the Cursors knob).
- 11 Tap the **Persistence** softkey; then select the **Infinite Persistence** display mode within the menu.

With Infinite Persistence turned on, the scope will display a permanent image of all captured waveforms (never erases). Without Infinite Persistence turned on, the scope erases all captured waveforms at a 60 Hz rate. Using Infinite Persistence can be extremely helpful when attempting to capture an extremely infrequently occurring event, such as a glitch that may occur just once every 2 hours. For example, you could set up an overnight test to see if any glitches occur and then find out if any occurred when you arrive back in your lab the next morning. The Infinite Persistence display mode is also useful for capturing and displaying worst-case timing jitter and noise. Note that in addition to the Infinite Persistence display mode, this scope also has a Variable Persistence display mode where you can define the waveform display erase rate.

Let's now setup the scope to uniquely trigger on this infrequent glitch using the scope's **Pulse Width** type triggering. But first, visually estimate the approximate width of this pulse relative to the trigger level setting, which should be set at approximately +1.0 V. It should appear to be approximately 30 ns wide.

- 12 Tap the **Persistence** softkey and select **Off** to turn off the persistence display mode.
- 13 Tap the **Clear Persistence** softkey.
- 14 Press the **[Trigger]** front panel key.
- 15 Tap the **Trigger – Edge** softkey; then use your finger to change from the default **Edge** type triggering to **Pulse Width** type triggering within the touchscreen menu.
- 16 Tap the **< 30 ns** softkey; then tap again to change the pulse width time from **< 30 ns** to **< 50 ns** using the onscreen keyboard.

At this point, the scope will be auto-triggering, rather than triggering on the glitch. This is because the infrequent glitch generated by these scopes is too infrequent for the scope's default Auto trigger mode. So this is a classic case for when you might need to use the Normal trigger mode (scope waits for trigger events to occur and doesn't generate automatic and asynchronous triggers). Let's select the Normal trigger mode.

- 17 Press the **[Mode/Coupling]** key in the Trigger section of the front panel.
- 18 Tap the **Mode-Auto** softkey; then select the **Normal** trigger mode.

You should now see a stable display showing just the narrow glitch similar to [Figure 30](#). With Pulse Width type triggering, you can define a unique width of a either a negative pulse or a positive pulse upon which to trigger. The available time variables include "<", ">", and a time range "><". The actual trigger point occurs at the end of the time-qualified pulse. In this example, since we have setup the scope to trigger on a positive pulse with a width less than 50 ns, the scope triggers on the trailing edge (falling edge) of the ~30 ns wide pulse. If you want to verify that there are not any glitches narrower than this 30 ns pulse, select the **[Trigger]** menu and re-adjust the pulse width time value to its minimum setting and see if your scope ever triggers.

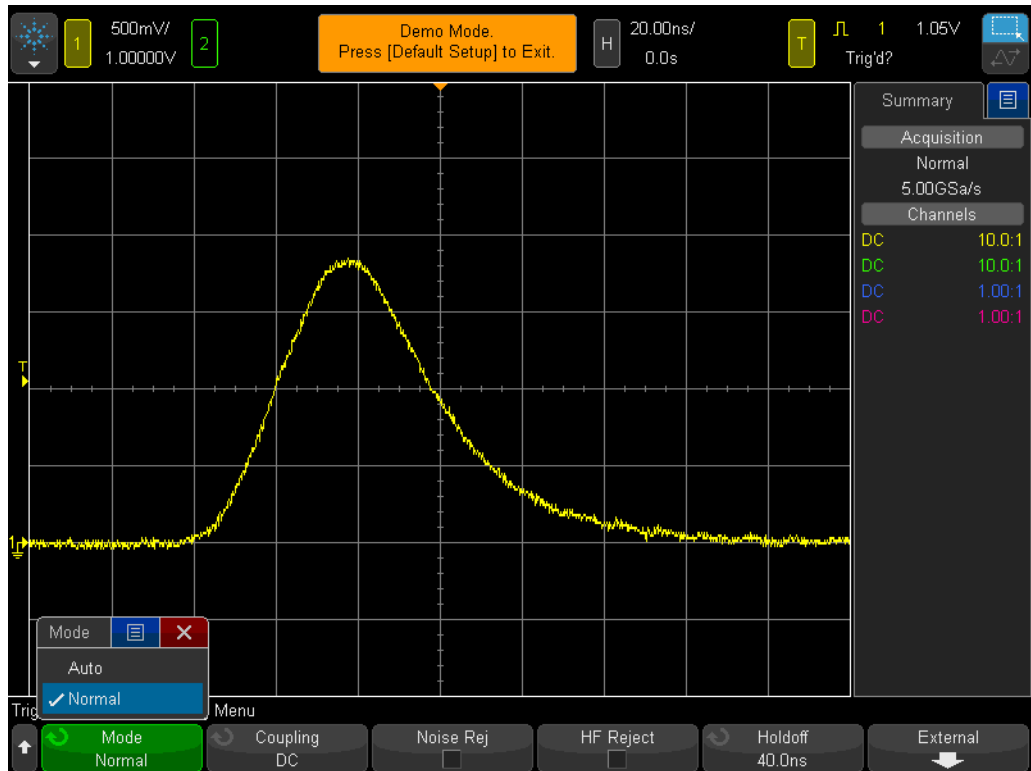

Figure 30 Using Pulse Width triggering to qualify on a uniquely narrow pulse

Pulse Width triggering is not only useful for triggering on unwanted glitches, but it can also be useful to establish a unique trigger point within a valid digital pulse train.

Lab #9: Capturing a Single-shot Event

If an event that you want to capture is truly “single-shot”, meaning that it only happens one time, you must have some knowledge of the signal’s characteristics in order to setup the scope to capture it. When capturing repetitive signals, you are typically able to view the captured waveform on-screen using various setup conditions, and then begin “tuning” the scope’s scaling until the waveform is properly scaled. But we don’t have that luxury with single-shot events.

So let’s assume that we know that the single-shot event that we want to capture is a digital pulse that should have an amplitude of approximately 2.5 V_{p-p} with an offset of +1.25 V. In other words, the signal should swing from ground (0.0 V) to approximately +2.5 V. Perhaps this is a system reset pulse that happens only during the boot up time.

A good vertical setting to capture this signal would then be 500 mV/div, which would enable us to capture up to a 4 V_{p-p} signal swing. A good offset/position setting would be +1.25 V in order to center the waveform on-screen, and a good trigger level would also be +1.25 V using a standard rising edge trigger condition.

And let’s assume that we also know that the width of our single-shot event should be about 500 ns wide. So a good timebase setting would be 200 ns/div. This would provide us with 2.0 μ s of capture time across screen, which would be more than enough to capture a 500 ns wide pulse. Let’s now set up the scope to capture this single-shot pulse.

- 1 Ensure that your two oscilloscope probes are still connected between the terminals labeled Demo1 & Demo2 and the Channel-1 & Channel-2 input BNCs respectively.
- 2 Press [**Default Setup**] on the scope’s front panel.
- 3 Set channel-1’s V/div setting to **500 mV/div**.
- 4 Set channel-1/s vertical position/offset to **+1.25 V**.
- 5 Set the trigger level to **+1.25 V**.
- 6 Set the scope’s timebase to **200.0 ns/div**.
- 7 Press the [**Mode/Coupling**] front panel key (next to the trigger level knob).
- 8 Tap the **Mode-Auto** softkey; then change from **Auto** to **Normal**.

Note that the **Normal** trigger mode must be used to capture a single-shot event. If you leave the scope in its default **Auto** triggering mode, the scope will continue to generate its own automatic asynchronous triggers and you will miss triggering on the single-shot event. The **Normal** trigger mode waits for a valid trigger event to occur (rising edge crossing at +1.25 V in

this case) before capturing and displaying anything. At this point, we should have the scope properly setup and waiting for a single-shot event to occur. So let's generate a single-shot event.

- 9 Press **[Help]**; then tap the **Training Signals** softkey.
- 10 Using the **Training Signals** menu, select the “**Single-shot Pulse with Ringing**” signal; then tap the **Output** softkey to turn it on. Note that this does **NOT** generate the single-shot event. It just enables this output.
- 11 Next, do **NOT** tap the **Auto Setup** softkey. The Auto Setup selection will overwrite the setups you just made. This feature is only useful for setting up the scope to capture this particular single-shot training signal. It is not available when setting up the scope to capture an arbitrary single-shot signal, which is what we are attempting to simulate.
- 12 Tap the **Transmit Single-shot** softkey to generate a single-shot event.

Your scope should have just captured this single-shot event and your scope's display should look similar to [Figure 31](#). Each time you press the **Transmit Single-shot** softkey, the scope will capture it again. To capture this event, we have been using the scope's **Normal** trigger mode in a **Run** acquisition mode. Let's now use the scope's **Single** acquisition mode.

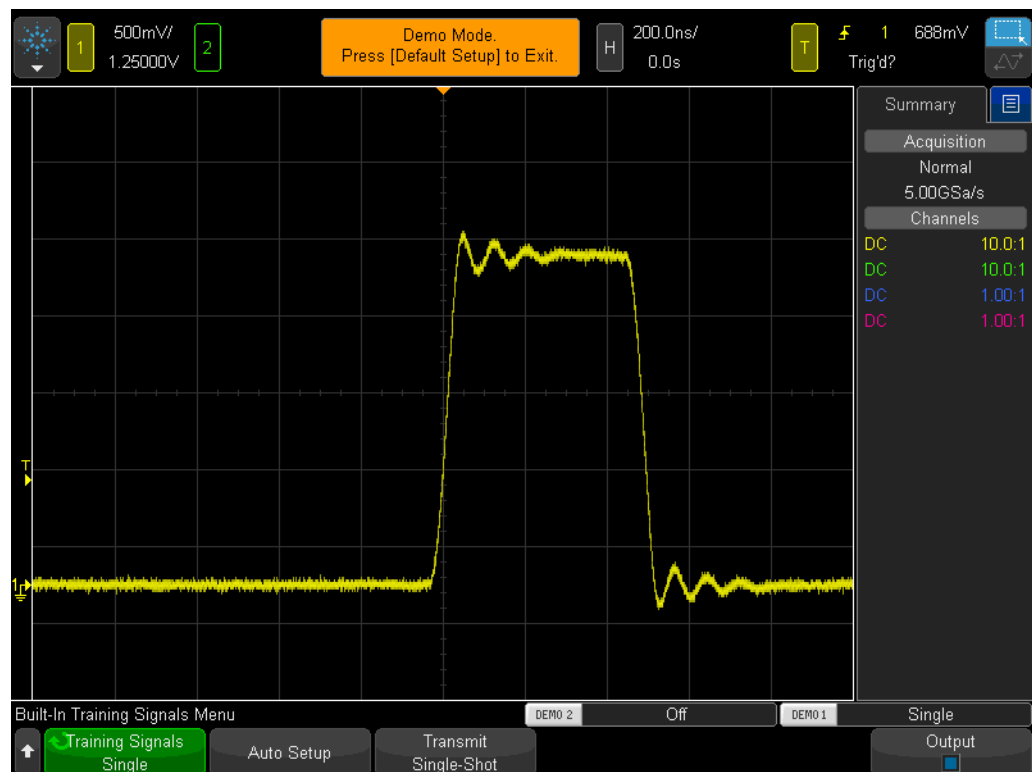

Figure 31 Setting up the scope to capture a single-shot event

3 Advanced Oscilloscope Measurement Labs

13 Press the scope's [**Single**] key in the upper right-hand corner of front panel.

14 Now tap the **Transmit Single-shot** softkey.

When using the scope's **Single** acquisition mode, the scope will capture a single-shot event *once and only once*. To re-arm the scope to capture another single-shot event, you must press [**Single**] again (before the single-shot occurs). Also note that the **Single** acquisition mode automatically selects the **Normal** trigger mode.

Lab #10: Performing Automatic Parametric Measurements on Digital Waveforms

During lab #1 of this EE/Physics oscilloscope training guide, you learned how to make simple voltage and timing measurements by either counting divisions and multiplying by the scope's scaling factors, or by using the scope's cursors function. You will now learn how to use the scope's automatic parametric measurement capability in order to perform these measurements (along with many additional measurements) quicker and more accurately.

- 1 Ensure that your two oscilloscope probes are still connected between the terminals labeled Demo1 & Demo2 and the Channel-1 & Channel-2 input BNCs respectively.
- 2 Press [**Default Setup**] on the scope's front panel.
- 3 Press [**Help**]; then tap the **Training Signals** softkey.
- 4 Using the **Training Signals** menu, select the "**Repetitive Pulse with Ringing**" signal; then tap the **Output** softkey to turn it on.
- 5 Set channel-1's V/div setting to **500 mV/div**.
- 6 Set channel-1's position/offset to **1.40 V**.
- 7 Press the trigger level knob in order to automatically set the trigger level at approximately **50%** (~1.3 V).
- 8 Set the scope's timebase to **500.0 ns/div**.

At this point you should see a repetitive digital pulse with overshoot and ringing similar to what is shown in [Figure 32](#).

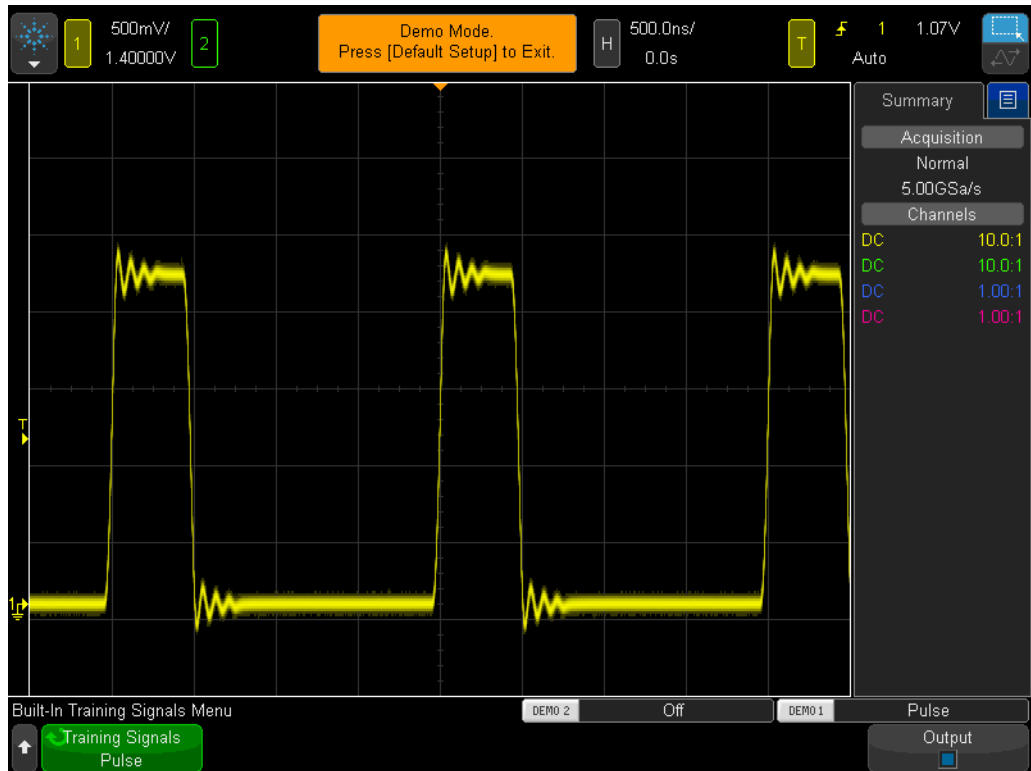

Figure 32 Oscilloscope setup to capture and display a repetitive digital pulse with ringing and overshoot

9 Press the **[Meas]** front panel key (next to the Cursors knob).

If beginning with a default setup (as we have done), when the **[Meas]** key is pressed the scope will turn on an automatic frequency and Vp-p measurement. Since this scope is able to show up to four continuously updated measurements, let's add two more measurements to this mix.

10 Open the **Type** menu and scroll up to select **Maximum**. To verify your choice, tap it again or tap the **Add Measurement** softkey.

11 Notice the level indicator that shows where this measurement is being performed.

12 Open the **Type** menu and select **Minimum**. To verify your choice, tap it again or tap the **Add Measurement** softkey.

Your scope's display should now be showing four continuously updated measurements; Frequency, Vp-p, Vmax, and Vmin. Let's now set up the scope to make four different pulse parameter measurements.

13 Tap the **Clear Meas** softkey; then tap the **Clear All** softkey.

14 Set the scope's timebase to **200.0 ns/div**. Expanding on the pulse will provide us with increased measurement resolution.

15 Now select to measure **Top**, **Base**, **Rise Time**, and **Fall Time**.

Your scope's display should now look similar to [Figure 33](#). If **Fall Time** was the last measurement that you selected, then the cursors will show where this measurement is being performed.

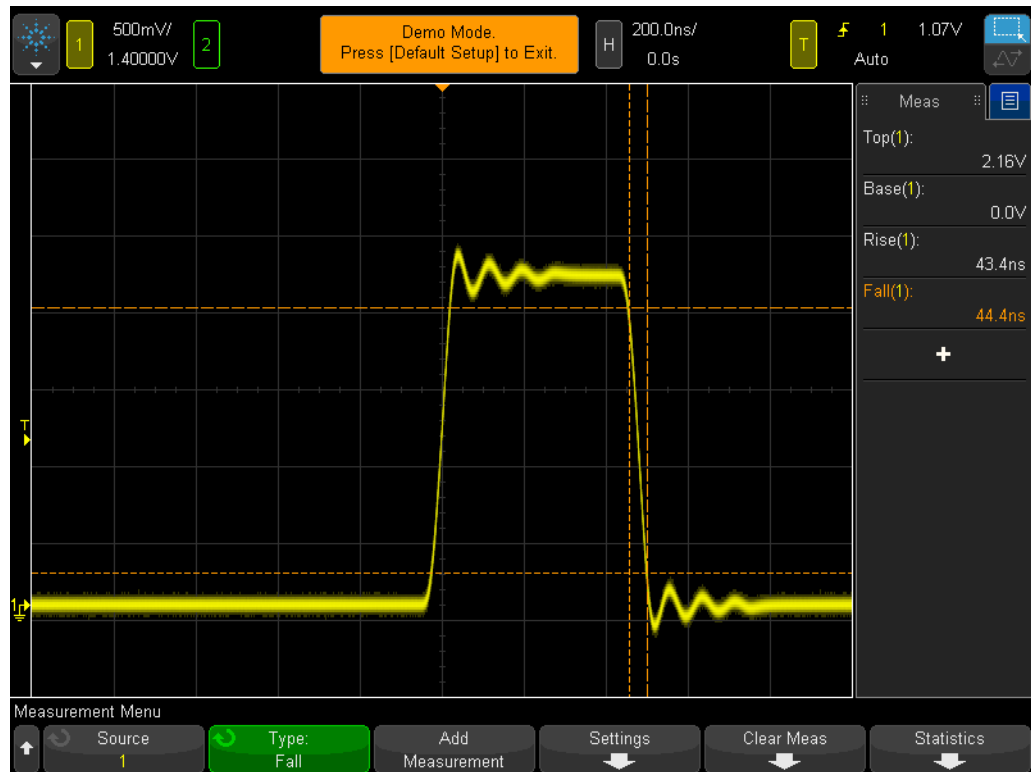



Figure 33 Performing additional pulse parameter measurements on a digital pulse

At this point you may be wondering what the difference is between the “top” of a waveform (V_{top}) versus the “maximum” of a waveform (V_{max}), as well as the difference between the “base” of a waveform (V_{base}) versus the “minimum” of a waveform (V_{min}).

V_{top} is the steady-state high level of the waveform. This is the voltage level of the waveform after the overshoot and ringing have settled. Likewise, V_{base} is the steady-state low level of the waveform. For digital pulse parameter measurements, V_{top} and V_{base} are often more important parameters to measure than the absolute maximum and minimum voltages of the waveform (V_{max} and V_{min}), which are the peak values of the overshoot.

The Rise Time and Fall Time measurements that we performed are relative transition times. This means that they have been performed relative to specific voltage threshold levels. The scope's default threshold levels for these measurements are the 10% and 90% levels relative to V_{base} and

Vtop. In other words, Vbase is considered the 0% level and Vtop is considered the 100% level. But many of today's higher speed devices have specified rise and fall times relative to 20% and 80% threshold levels, or perhaps relative to absolute voltage levels, such as from/to ± 1.0 V. Let's now setup our scope to measure just the rise time of this pulse relative to the 20% and 80% threshold levels.

- 16 Tap the **Clear Meas** softkey; then tap the **Clear All** softkey.
- 17 Tap the **Settings** softkey; then tap the **Thresholds** softkey.
- 18 Tap the **Lower** softkey twice to open the keypad; enter **20%**.
- 19 Tap the **Upper** softkey twice to open the keypad; enter **80%**.
- 20 To return to the previous menu, press the  (Back) front panel key (just above the power switch).
- 21 Press the  (Back) key again since we descended two levels into this menu.
- 22 Open the **Type** menu; scroll and select **Rise Time**.
- 23 Now either tap the **Add Measurement** softkey, or tap the **Entry** knob to add this measurement.

Using these user-defined measurement threshold levels (20% and 80%), our rise time measurement should be faster since we are now measuring across a shorter segment of the waveform as shown in [Figure 34](#). The measurement should now read approximately 30 ns. When we used the scope's default 10%/90% threshold levels, the measurement should have read approximately 40 ns.

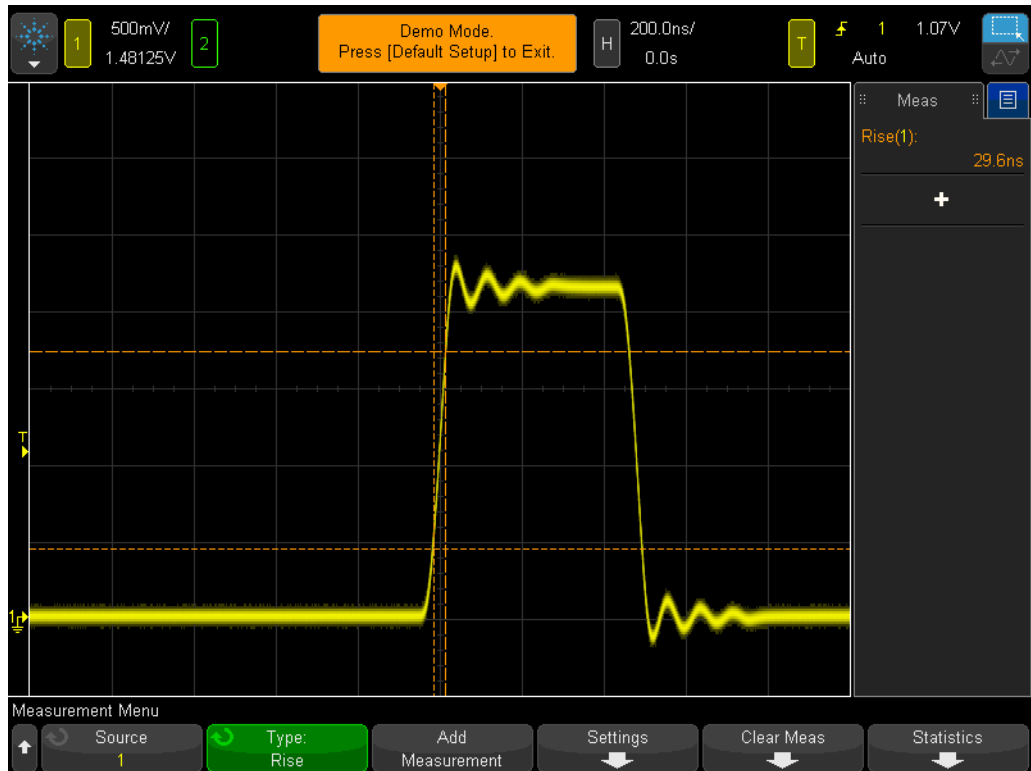

Figure 34 Performing a rise time measurement relative to 20% and 80% threshold levels

During step #14 of this lab, we mentioned that expanding on the waveform would provide us with increased measurement resolution and accuracy. Try setting the timebase to $50.0 \mu\text{s}/\text{div}$ and notice the reduction in measurement resolution.

Let's now make one more measurement before completing this lab. But this time let's perform a more comprehensive set of measurements on this waveform.

24 Set the scope's timebase to **500.0 ns/div**.

25 Tap the **Type** softkey; then select **Snapshot All** (top of the list).

26 Now either tap the **Add Measurement** softkey, or select it again to add this set of measurements.

The "Snapshot-All" measurement provides us with a one-time (snapshot) measurement of several parameters in order to completely characterize our input signal as shown in [Figure 35](#). Note that this set of measurements is not continuously updated, and if you press any front panel key or softkey, the display of these measurements will disappear.

3 Advanced Oscilloscope Measurement Labs

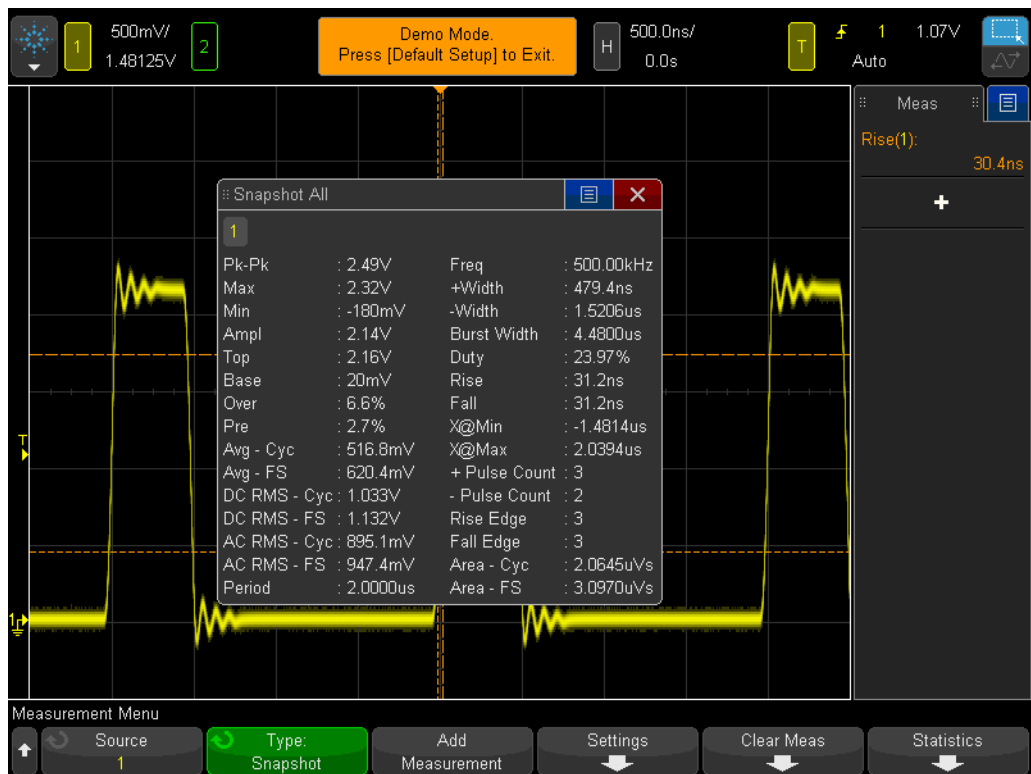

Figure 35 Performing a comprehensive set of automatic parametric measurements using the “Snapshot All” function

Lab #11: Using the Scope's Zoom Timebase to Perform Gated Measurements

When performing automatic parametric measurements, such as positive pulse width measurements, on an exactly repetitive input signal, such as a simple sine wave or square wave, it really doesn't matter which particular pulse the scope chooses to make the measurement on... each pulse is the same. But what if the input signal you are probing is more complex; where each pulse has unique parametric characteristics? In this case, you would first need to set up the scope to trigger at a unique point in time on the complex signal, and then you would need to set up the scope's measurements in such a way that the scope would be more selective as to which pulse it chooses to perform measurements on. In this lab, you will learn how to perform selective, or "gated", measurements on specific pulses using the scope's Zoom timebase mode.

- 1 Ensure that your two oscilloscope probes are still connected between the terminals labeled Demo1 & Demo2 and the Channel-1 & Channel-2 input BNCs respectively.
- 2 Press **[Default Setup]** on the scope's front panel.
- 3 Press **[Help]**; then tap the **Training Signals** softkey.
- 4 Using the **Training Signals** menu, select the "**Digital Burst with Infrequent Glitch**" signal; then tap the **Output** softkey to turn it on.
- 5 Set channel-1's V/div setting to **1.0 V/div**.
- 6 Set channel-1's position/offset setting to approximately **2.0 V** in order to center the waveform on-screen.
- 7 Press the trigger level knob in order to automatically set the trigger level at approximately **50%** (~1.7 V).
- 8 Set the scope's timebase to **1.000 μ s/div**.

Note that at this setting you may notice some "flickering" of the waveform. This "flickering" may appear as waveform "ghosts" occurring prior to the burst of pulses. If you turn the scope's waveform intensity to 100%, this will become more clear. The cause of the "flickering" is because the scope usually triggers on the 1st rising edge in this digital burst, but sometimes triggers on later edges. We need to use the scope's trigger holdoff feature in order to force the scope to only trigger on the 1st rising edge of the burst.

- 9 Press the **[Mode/Coupling]** front panel key near the trigger level knob.
- 10 Tap the **Holdoff** softkey twice to activate the keyboard. Set the trigger holdoff value to **4.0 μ s**.

With the scope's trigger holdoff feature turned on and set to 4.0 μ s, the scope now triggers on the 1st rising edge of the burst, disarms triggering for 4.0 μ s, and then re-arms triggering after the last pulse in the burst so

3 Advanced Oscilloscope Measurement Labs

that the scope will again trigger on the 1st pulse during the next repetition of the burst. We have now established a stable and unique trigger point on this complex digital signal using Trigger Holdoff.

You should now observe 6 positive pulses with varying widths, plus an infrequent glitch occurring after the 6th pulse as shown in [Figure 36](#). Let's now turn on a "+ Width" measurement.

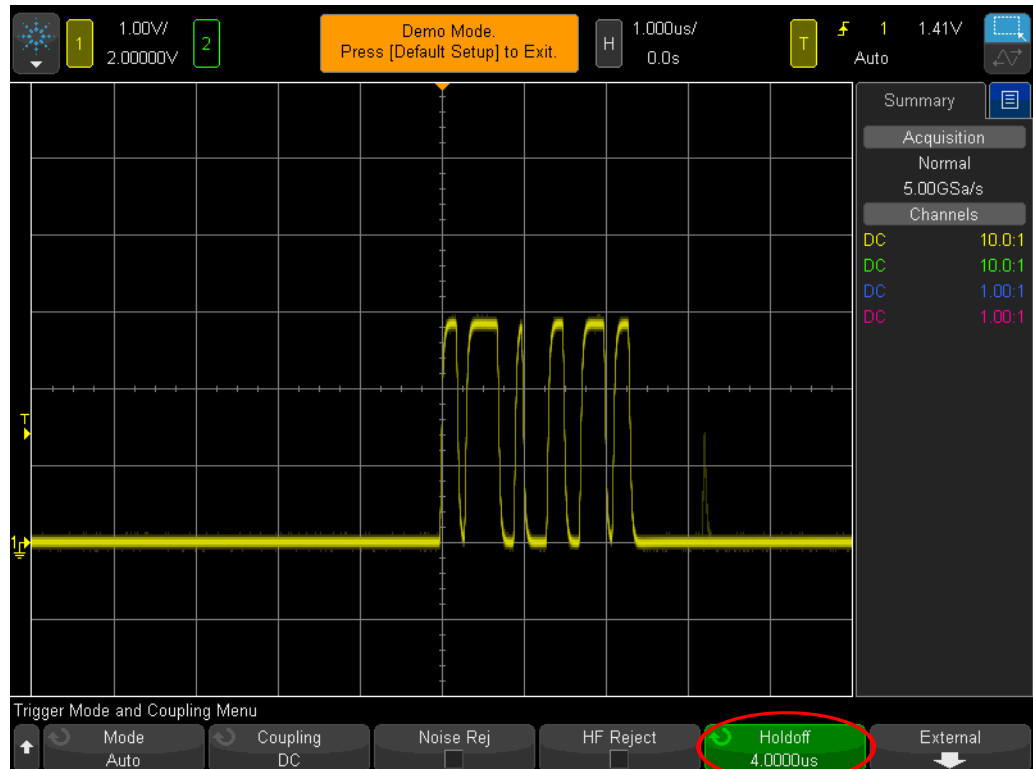

Figure 36 Setting up the oscilloscope to capture a burst of digital pulses with different pulse widths

- 11 Press the **[Meas]** front panel key (next to the Cursors knob).
- 12 Tap the **Clear Meas** softkey; then tap the **Clear All** softkey.
- 13 Open the **Type** menu and select the **+ Width** measurement.
- 14 Either select it again or tap the **Add Measurement** softkey to select this measurement.

The scope always performs measurements on the pulse located closest to center-screen. In this case the scope measures the positive pulse width of the 1st pulse in this digital burst as shown in [Figure 37](#). But what if we want to know the widths of the 2nd, 3rd, 4th, etc., pulses?

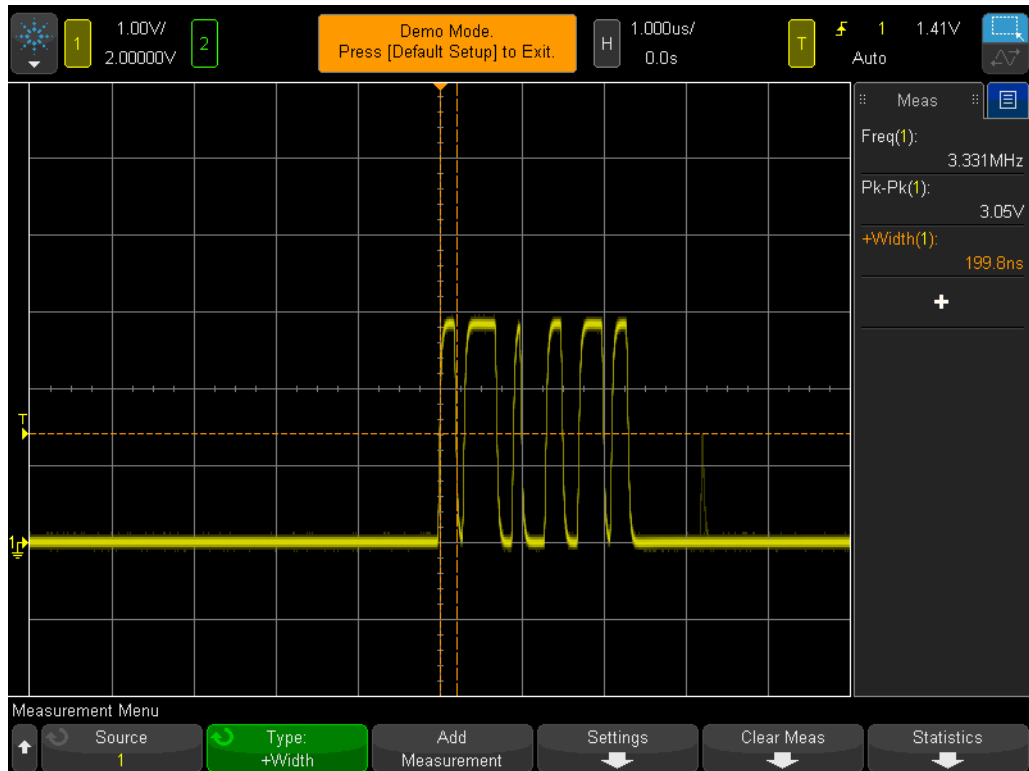

Figure 37 Measuring the positive pulse width of the 1st pulse in the burst

- 15 Press the \odot button in the Horizontal section of the front panel to turn on the scope's "zoom" timebase mode.
- 16 Set the Zoom timebase to **50.00 ns/div** by turning the large timebase knob.
- 17 Set the horizontal position to **100.0 ns** by turning the horizontal position knob.

When the "zoom" timebase has been turned on, the horizontal controls (s/div and position) control the zoomed (or expanded) timebase settings. If your professor is more familiar with older analog oscilloscope operation, he/she may refer to this mode of operation as the "Delayed Sweep" timebase mode.

3 Advanced Oscilloscope Measurement Labs

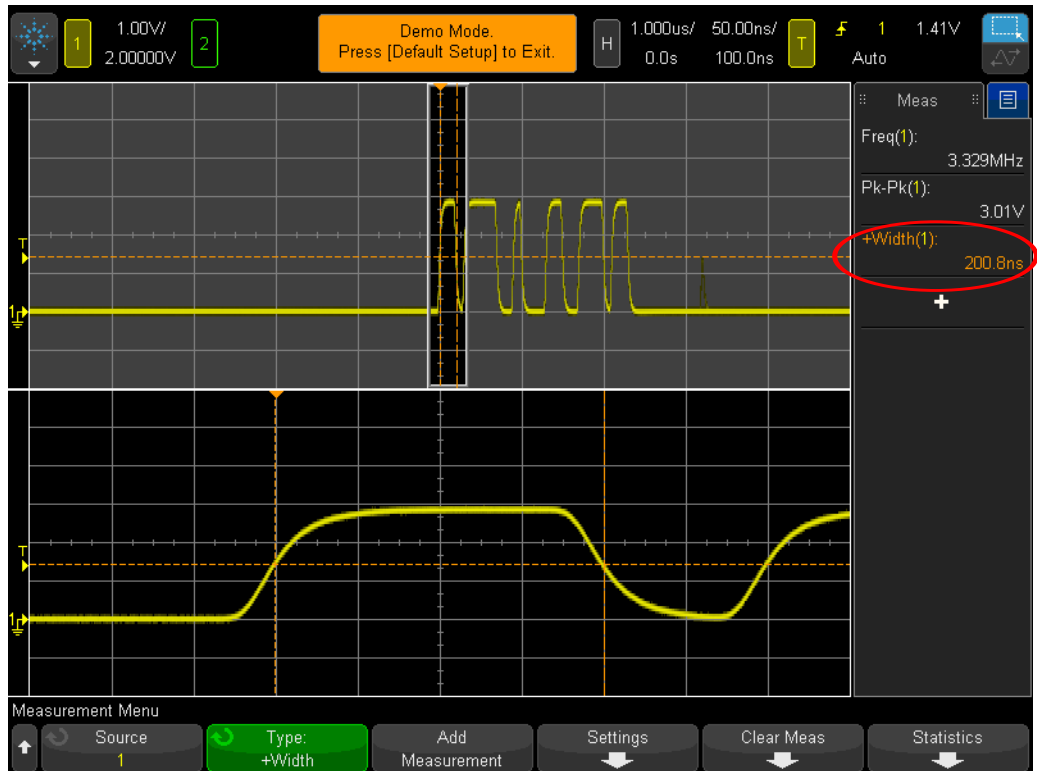

Figure 38 Using the scope’s Zoom timebase mode to perform “gated” measurements

You should now see on your scope’s display an expansion of just the 1st pulse in this burst in the lower portion of the display as shown in [Figure 38](#). The + Width measurement should be measuring the positive pulse width of just the 1st pulse. What is the width of this pulse?

$$+ \text{ Width (1st pulse) } = \underline{\hspace{2cm}}$$

Let’s now measure the width of the 2nd pulse.

18 Set the horizontal position/delay to **500.00 ns** in order to “window” on the 2nd pulse.

What is the width of the 2nd pulse?

$$+ \text{ Width (2nd pulse) } = \underline{\hspace{2cm}}$$

19 Measure the width of the remaining 4 pulses (excluding the infrequent glitch) by “windowing” on each pulse.

+ Width (3rd pulse) = _____

+ Width (4th pulse) = _____

+ Width (5th pulse) = _____

+ Width (6th pulse) = _____

Lab #12: Phase Delay Measurements and Lissajous Waveforms

In this lab, you will learn how to make two channel measurements on phase delayed sine waves. Performing this type of measurement may be important if you wanted to look at the phase response of an inverting amplifier. This lab will show you how to measure the phase response between an input and an output. In addition, you will also learn how to view these waveforms as a Lissajous curve.

- 1 Ensure that your two oscilloscope probes are still connected between the terminals labeled Demo1 & Demo2 and the Channel-1 & Channel-2 input BNCs respectively.
- 2 Press [**Default Setup**] on the scope's front panel.
- 3 Press the [**2**] front panel key to turn on Channel-2.
- 4 Press [**Help**]; then tap the **Training Signals** softkey.
- 5 Double-click the "**Phase Shifted Sine**" signal in the **Training Signals** menu to turn it on.
- 6 Set channel-1's V/div setting to **500 mV/div**.
- 7 Set channel-2's V/div setting to **500 mV/div**.
- 8 Set the scope's timebase to **200.0 μ s/div**.

At this point you should see two sine waves with the one captured by channel-2 delayed from the one captured by channel-1 by approximately 90 degrees as shown in [Figure 39](#). Let's now measure the delay time and phase shift using the scope's two-channel automatic measurements.

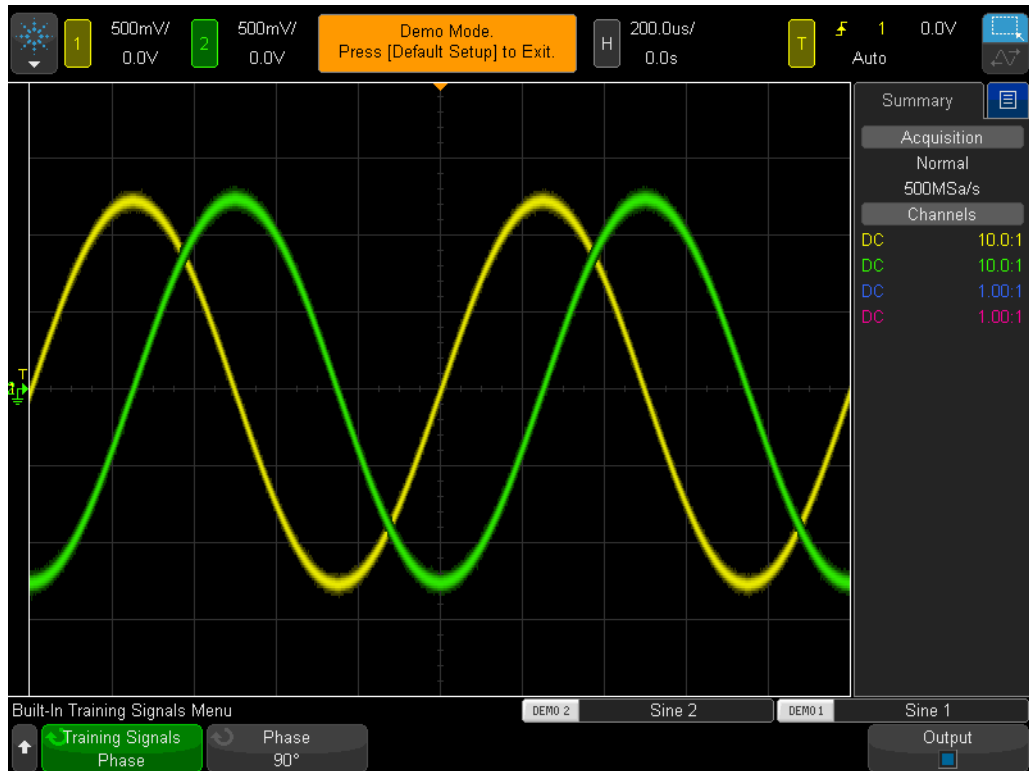

Figure 39 Performing measurements on phase delayed signals

- 9 Press the **[Meas]** front panel key (next to the Cursors knob).
- 10 Tap the **Type** softkey; then scroll to the **Delay** measurement.
- 11 Either tap the **Add Measurement** softkey, or double-click to add this measurement.
- 12 Next, scroll to the **Phase** measurement.
- 13 Either tap the **Add Measurement** softkey, or double-click to add this measurement.

Your scope should now have four measurements on screen; two default measurements (frequency and Vp-p), plus the delay time and phase shift measurements. Let's now vary the phase shift between these two signals.

- 14 Press **[Help]**; then tap the **Training Signals** softkey (this restores our Training Signals menu).
- 15 Tap the **Phase** softkey; then rotate the **Entry** knob to vary the phase shift from 0 to 360 degrees. You can also click the **Phase** softkey to explicitly assign a phase angle.

3 Advanced Oscilloscope Measurement Labs

Let's now view these waveforms in a different format; probably one of your professors favorite oscilloscope display formats! We will view these waveforms as a Lissajous curve; named after Jules Antoine Lissajous (1822-1880), who was a French mathematician.

- 16 Press the **[Horiz]** front panel key (near the scope's timebase controls).
- 17 Tap the **Time Mode** softkey and select **XY**. Select it again or tap the red X to close the menu.
- 18 Press **[Help]**; then tap the **Training Signals** softkey.
- 19 Tap the **Phase** softkey; then rotate the **Entry** knob to vary the phase shift.

The scope is no longer plotting our waveforms in a Volts versus Time format. It is now plotting our waveforms in a Volts (ch1) versus Volts (ch2) format. When the phase shift is exactly 90 degrees or 270 degrees, we should see a perfect circle. When the phase shift is exactly 0 degrees, we should see a rising line at 45 degrees. When the phase shift is exactly 180 degrees, we should see a falling line at 45 degrees. At any other phase settings, we should see an oval curve as shown in [Figure 40](#). Lissajous curves of sine waves of the same frequency produce the simplest curve shapes.

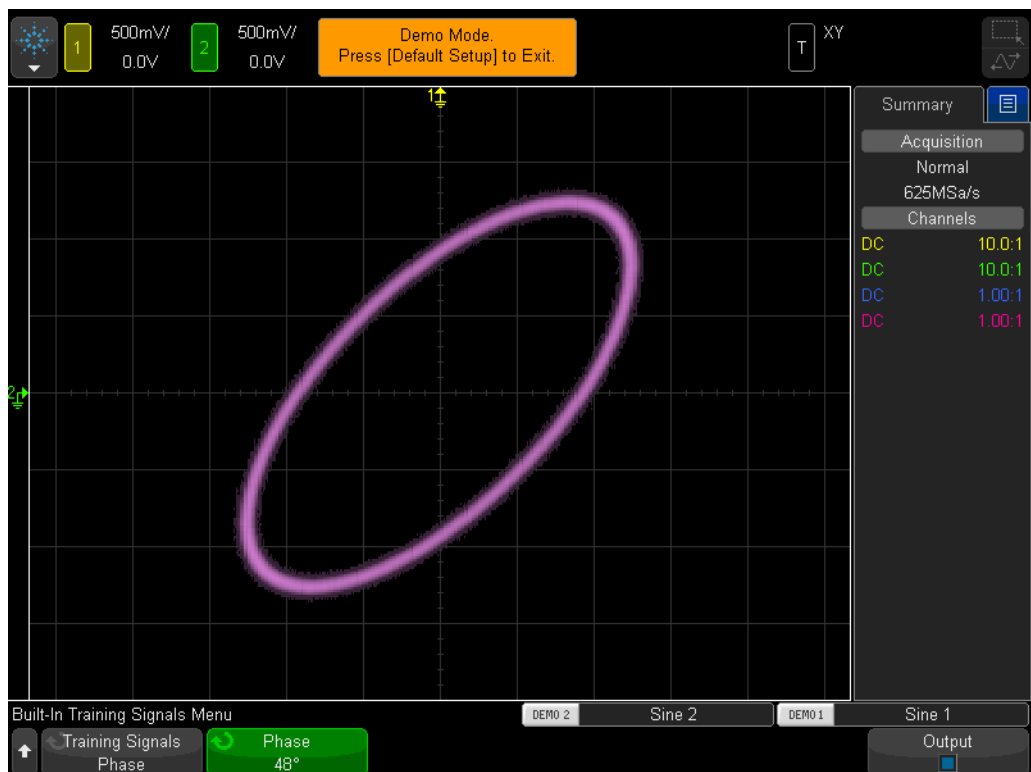

Figure 40 A Lissajous pattern using a scope's XY mode of two sine waves of the same frequency, but 48 degrees out of phase with each other

Analog amplifier engineers sometimes use Lissajous curves on an oscilloscope to fine-tune their circuitry. Lissajous patterns can sometimes be very complex, but the analog engineer usually knows the pattern he/she is looking for. Figure 41 shows a more complex Lissajous pattern of two signals with different frequencies.

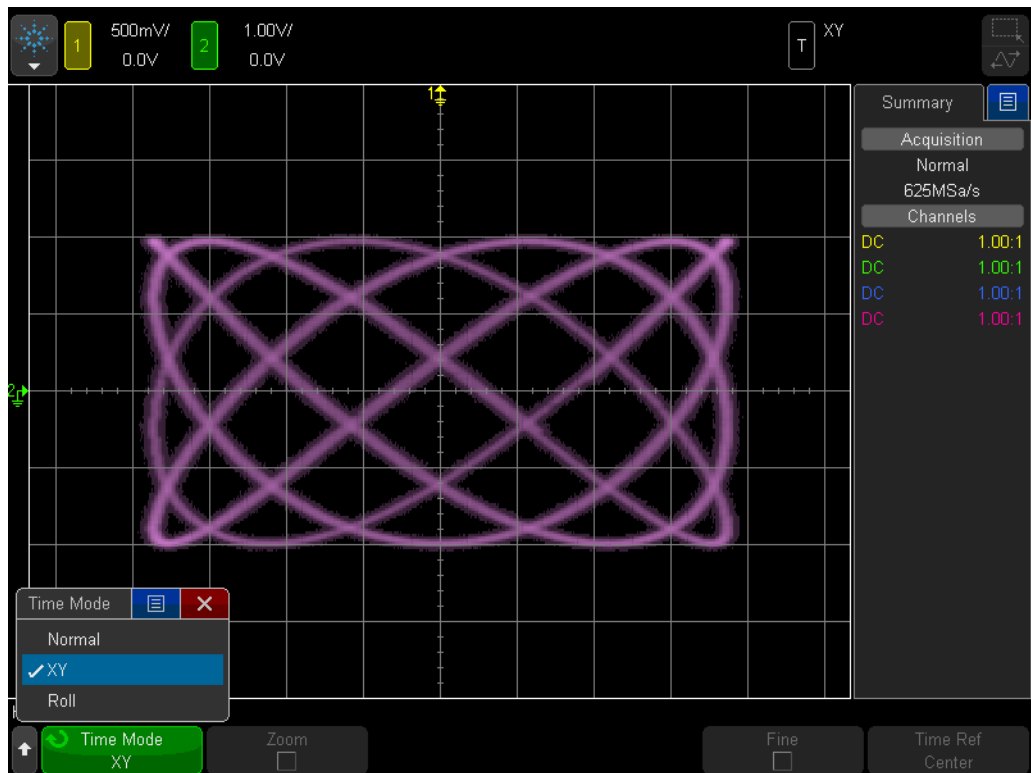

Figure 41 A more complex Lissajous pattern derived from two signals of different frequencies

Lab #13: Using Oscilloscope Waveform Math

In addition to performing automatic parametric measurements on waveform data, the oscilloscope can also perform math operations on an entire waveform or pair of waveforms. One very common waveform math function that you may want the scope to perform is to subtract one waveform from another. For instance, if you were using standard 10:1 passive probes to capture waveforms on your circuit, you would be limited to capturing these waveforms relative to ground only. But what if you wanted to see what a waveform looks like across a particular component where neither end of the component is connected to ground? In this case you could capture waveforms at both ends of the component relative to ground, and then subtract one waveform from the other. Let's try it.

- 1 Ensure that your two oscilloscope probes are still connected between the terminals labeled Demo1 & Demo2 and the Channel-1 & Channel-2 input BNCs respectively.
- 2 Press **[Default Setup]** on the scope's front panel.
- 3 Press the **[2]** front panel key to turn on Channel-2.
- 4 Press **[Help]**; then tap the **Training Signals** softkey.
- 5 Select the "**Phase Shifted Sine**" signal from the **Training Signals** menu.
- 6 Set channel-1's V/div setting to **500 mV/div**.
- 7 Set channel-2's V/div setting to **500 mV/div**.
- 8 Set the scope's timebase to **200.0 μ s/div**.
- 9 Press the **[Math]** front panel key (right side of front panel).
- 10 Tap the **Operator** softkey menu and choose **Subtract**.

You should now see three waveforms on your scope's display as shown in [Figure 42](#). The purple waveform is the result of the scope's math function of subtracting the channel-2 waveform from the channel-1 waveform. Let's now vary the phase shift of the two sine waves and observe the results.

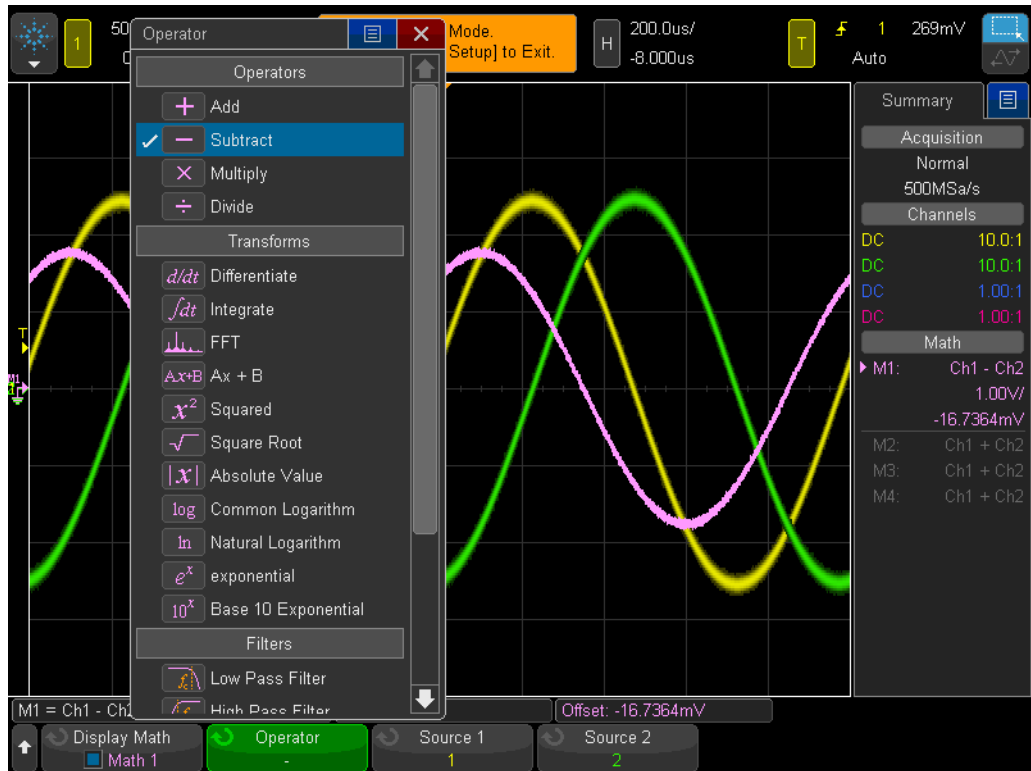

Figure 42 Using waveform math to subtract channel-2 from channel-1

- 11 Press the **[Help]** front panel key; then tap the **Training Signals** softkey.
- 12 Tap the **Phase** softkey; then rotate the **Entry** knob to vary the phase shift, or double tap the button to explicitly set the phase shift.

When the phase shift is exactly 180 degrees, the resultant math waveform will be at its highest amplitude as expected. When the phase shift is exactly 0 or 360 degrees, the resultant math waveform flat-lines (0.0 V). Note that you can change the scaling of the math waveform using the knobs on the right-hand side of the scope's front panel near the **[Math]** key. Let's now perform a more complex math function; FFT (Fast Fourier Transform).

- 13 Press **[Default Setup]**.
- 14 Press **[Help]**; then tap the **Training Signals** softkey.
- 15 Double-click the "**Clock with Infrequent Glitch**" signal using the **Training Signals** softkey.
- 16 Set channel-1's V/div setting to **500 mV/div**.
- 17 Set channel-1's offset to approximately **1.00 V** in order to center the waveform on-screen.

- 18 Press the trigger level knob to set the trigger level at approximately **50%**.
- 19 Set the timebase to **100.0 ns/div**. At this timebase, the **Meas** feature can be used to accurately measure the clock frequency. Tap **Meas** and verify a clock frequency of ~ 3.56 MHz on the right of the display. Tap **Meas** again to disable.
- 20 Set the timebase to **100.0 μ s/div**. At this timebase setting there will be many cycles of the clock signal on-screen, which is typically required when performing a precision FFT math function.
- 21 Press the [**Math**] front panel key; then tap the **Operator** softkey.
- 22 Double-click the **FFT** math function to select and enable the signal.

You should now see a display similar to [Figure 43](#). The scope is now displaying both a time domain waveform (Voltage versus Time) as well as a frequency domain waveform (Power in units of dB versus Frequency). An FFT math function breaks signals down into their individual sine wave frequency components. And if you remember from some of your EE circuits or Physics classes, all electrical signals, including digital signals, are composed of multiple sine waves of different frequencies. An ideal clock signal that has a 50% duty cycle should consist of a fundamental sine wave frequency component (signal's repetitive frequency), plus its odd harmonics (3rd, 5th, 7th, etc.). Note that non-ideal square waves will also include lower-level even harmonics. Let's now verify the frequencies of the fundamental and odd harmonics.



Figure 43 Performing an FFT math function on a repetitive digital clock

- 23 Press the [**Cursors**] front panel key (near the Cursors knob).
- 24
- 25 Tap the **Source** softkey and change the **Source** from channel-1 to **Math: f(t)**. The cursors will now be doing measurements on the purple FFT trace.
- 26 Drag the **X1** cursor flag across the bottom of the screen until it aligns with the first frequency peak. This is the fundamental frequency component, and should equal the clock speed.
- 27 Drag the **X2** cursor flag across the bottom of the screen until it aligns with the third frequency peak. This is the third harmonic, triple that of the fundamental frequency. Your screen should look similar to [Figure 43](#).
- 28 What is the X1 frequency, which is the fundamental component (readout to the right of the display)?

F1 = _____

- 29 What is the X2 frequency, which should be the 3rd harmonic?

F3 = _____

Lab #14: Using Peak Detect to Overcome Under-sampling

All DSOs and MSOs have a fixed amount of acquisition memory. This is the number samples that the oscilloscope can digitize for each acquisition cycle. If the scope's timebase is set to a relatively fast sec/div setting, such as 20 ns/div, then the scope will always have a sufficient amount memory to capture a waveform at that setting using the scope's maximum specified sample rate. For example, if a scope's maximum specified sample rate is 2 GSa/s (500 ps between samples), and if the scope's timebase is set to 20 ns/div, then an acquisition memory depth of 400 points is all that is required to capture and display a complete waveform. At 20 ns/div, a complete waveform across the scope's screen would consist of 200 ns of time (20 ns/div x 10 horizontal divisions). The required memory depth to fill this time while still sampling at 2 GSa/s is then just 400 points (200ns/500ps = 400).

If you set the scope's timebase to a much slower sec/div setting in order to capture slower waveforms and longer time, then the scope may need to automatically reduce its sampling rate in order to fill the required waveform time. All DSOs and MSOs do this. For example, let's assume that you want to capture a relatively slow signal and need to set the scope's timebase to 10 ms/div (100 ms across screen). If the scope's maximum memory depth is 100k points, then the scope will need to reduce its sample rate to 1 MSa/s (100ms/100k = 1 μ s sample period).

Although in most cases this is not a problem, since capturing slower waveforms doesn't require fast sample rates, what if the input signal consisted of a combination of low-speed and high-speed characteristics? For example, what if the input signal that you want to capture is a 30 Hz sine wave with very narrow glitches riding on it? Capturing the 30 Hz sine wave doesn't require a fast sample rate, but capturing the narrow glitches may require a very fast sample rate. Let's set up a test to capture a signal such as this.

- 1 Ensure that your two oscilloscope probes are connected between the terminals labeled Demo1 & Demo2 and the Channel-1 & Channel-2 input BNCs respectively.
- 2 Press **[Default Setup]** on the scope's front panel.
- 3 Press **[Help]**; then tap the **Training Signals** softkey.
- 4 Using the **Training Signals** menu, select the "**Sine with Glitch**" signal; then select it again to turn it on.
- 5 Set channel-1's V/div setting to **500.0 mV/div**.
- 6 Set the scope's timebase to **10.00 ms/div**.
- 7 Press the **[Intensity]** button (under the **Entry** knob); then set the waveform trace intensity to **100%** using the **Entry** knob or on-screen slider.

At this point you should see a sine wave similar to [Figure 44](#). But if you look closely you should also see some glitches (narrow pulses) near the peaks of this sine wave. And the amplitude of these glitches may appear to vary (bouncing up and down). The amplitude of these glitches is actually very stable. The problem is that the scope has reduced its sample rate (note the sample rate shown under the Agilent logo on the scope's display) and the scope is now intermittently capturing the narrow glitches. The scope is under-sampling the narrow glitches. Sometimes the scope captures a single point on the peak of a glitch. Sometimes it captures a point on a transition of the glitch. And sometimes it captures nothing at all on the glitch (the glitch width is narrower than the sample interval). This scope has a special acquisition mode called "Peak Detect" that will resolve this problem. Let's turn it on.

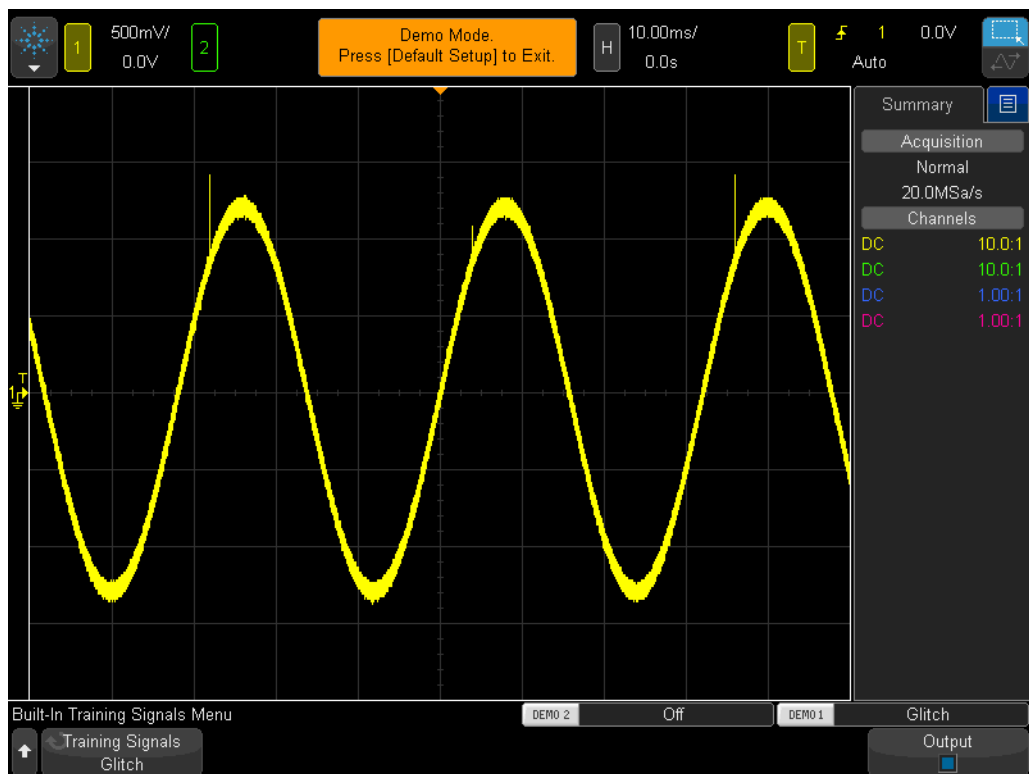

Figure 44 The scope's automatically-reduced sample rate under-samples the repetitive glitch

- 8 Press the [**Acquire**] front panel key (below the Cursors knob).
- 9 Tap the **Acq Mode** softkey; then rotate the **Entry** knob to select **Peak Detect**.

The height of the glitches should now appear much more stable as shown in [Figure 45](#). When the **Peak Detect** acquisition mode has been selected, rather than sampling waveforms at a reduce rate, the scope intelligently

3 Advanced Oscilloscope Measurement Labs

decimates acquired data at a higher sample rate. For example, let's assume that the scope needs to run at a sample rate that is 1/100th of its maximum sample rate. This would be equivalent to running the scope at its maximum sample rate, but only storing every 1/100th point, which is "unintelligent" decimation. In the Peak Detect mode, the scope would analyze a group of 200 consecutive samples in real-time (sampled at a high rate), and then store just the maximum and minimum digitized values for this group of 200 points, which is just 2 points. This would be a decimation factor of 100.

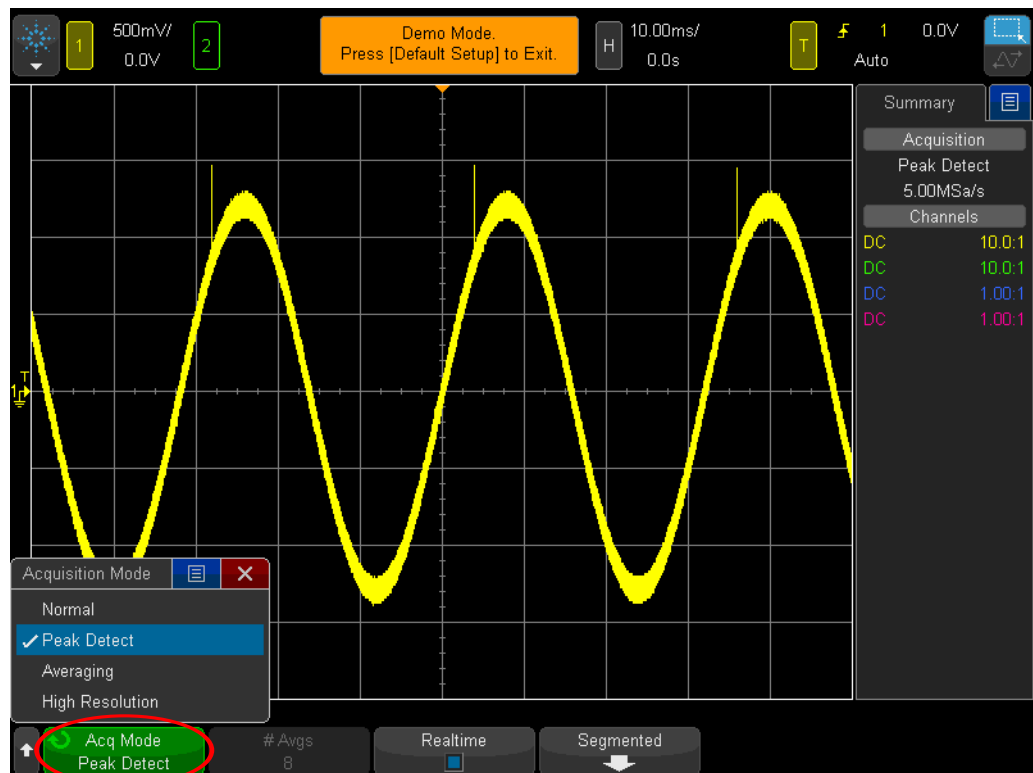

Figure 45 The Peak Detect acquisition mode reliably captures the narrow glitches riding on the slow sine wave

So you may ask why not always use the **Peak Detect** mode? There are some tradeoffs when using this mode of acquisition. First of all, the scope's absolute maximum sample rate is reduced. Secondly, stored points will NOT be evenly spaced. And this is an important criterion of the Nyquist Sampling theorem. So for this particular measurement application, using the **Peak Detect** mode is a good choice. But for other measurement applications, **Peak Detect** may not be the appropriate acquisition mode.

To learn more about oscilloscope real-time sampling, refer to Agilent's document titled, "*Evaluating Oscilloscope Sample Rates vs Sampling Fidelity*". This application note is listed at the end of this document with instructions on how to download.

Lab #15: Using Segmented Memory to Capture More Waveforms

As you learned in the previous lab, all oscilloscopes have a limited amount of acquisition memory. And the amount of acquisition memory that your scope has will determine the length of time it can capture while still using a fast sampling rate. You can always capture a long time span by simply setting the timebase to a long sec/div setting. But the scope may automatically reduce its sample rate in order to capture the long time-span which will reduce acquired waveform detail and measurement resolution. Using this scope's Segmented Memory acquisition mode is another solution to optimize memory depth and sample rate; especially when attempting to capture multiple low duty cycle type signals. Let's now attempt to capture and display a simulated low duty cycle radar burst.

- 1 Ensure that your two oscilloscope probes are still connected between the terminals labeled Demo1 & Demo2 and the Channel-1 & Channel-2 input BNCs respectively.
- 2 Press **[Default Setup]** on the scope's front panel.
- 3 Press **[Help]**; then tap the **Training Signals** softkey.
- 4 Using the **Training Signals** menu, double-click the "RF Burst" signal to turn it on.
- 5 Set channel-1's V/div setting to **500.0 mV/div**.
- 6 Set the scope's timebase to **200.00 ns/div**.
- 7 Set the scope's trigger level to approximately **+900 mV** (~2 divisions above center-screen).
- 8 Press the **[Intensity]** button (under the **Entry** knob); then set the waveform trace intensity to **100%** using the **Entry** knob.

You should see a single burst of sine waves similar to what is shown in [Figure 46](#). Let's now rescale the timebase in an attempt to capture several of these bursts.

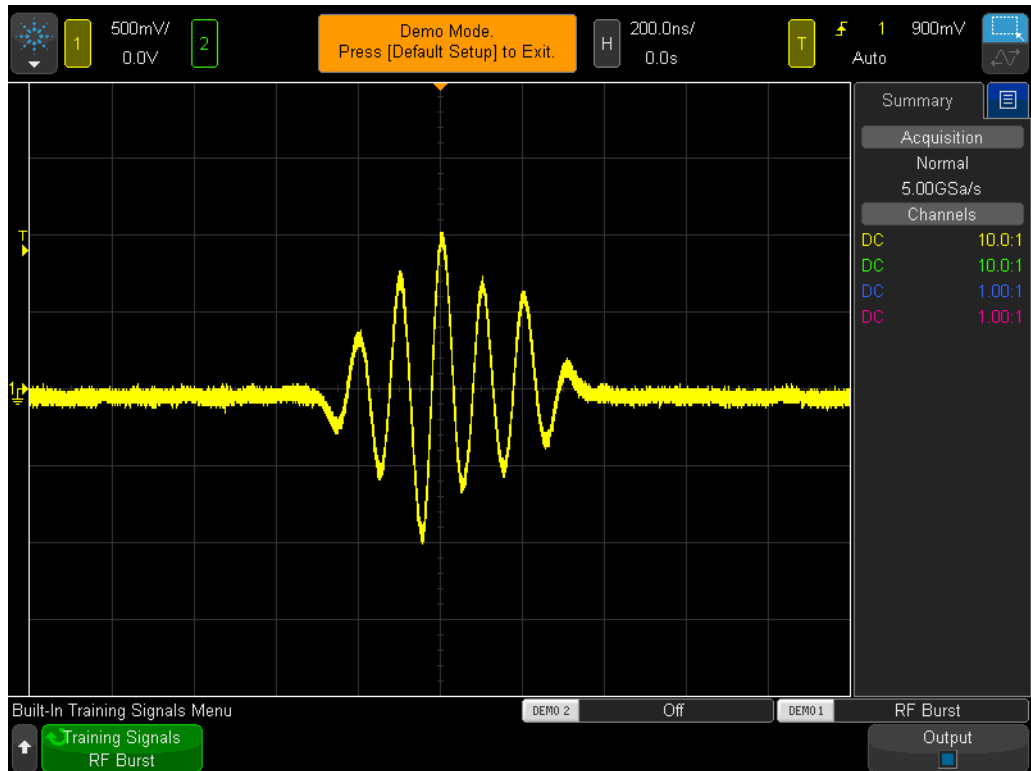

Figure 46 Capturing and displaying an RF burst at 200.0 ns/div

9 Set the scope's timebase to **10.000 ms/div**.

When attempting to capture multiple RF bursts that are separated by 4.0 ms, the scope under-samples and shows varying amplitudes of the signal as shown in [Figure 47](#). Again, this is because the scope automatically reduced its sample rate in order to capture a longer time-span with its limited amount of acquisition memory. Now zoom-in and take a closer look at this under-sampled data.

3 Advanced Oscilloscope Measurement Labs

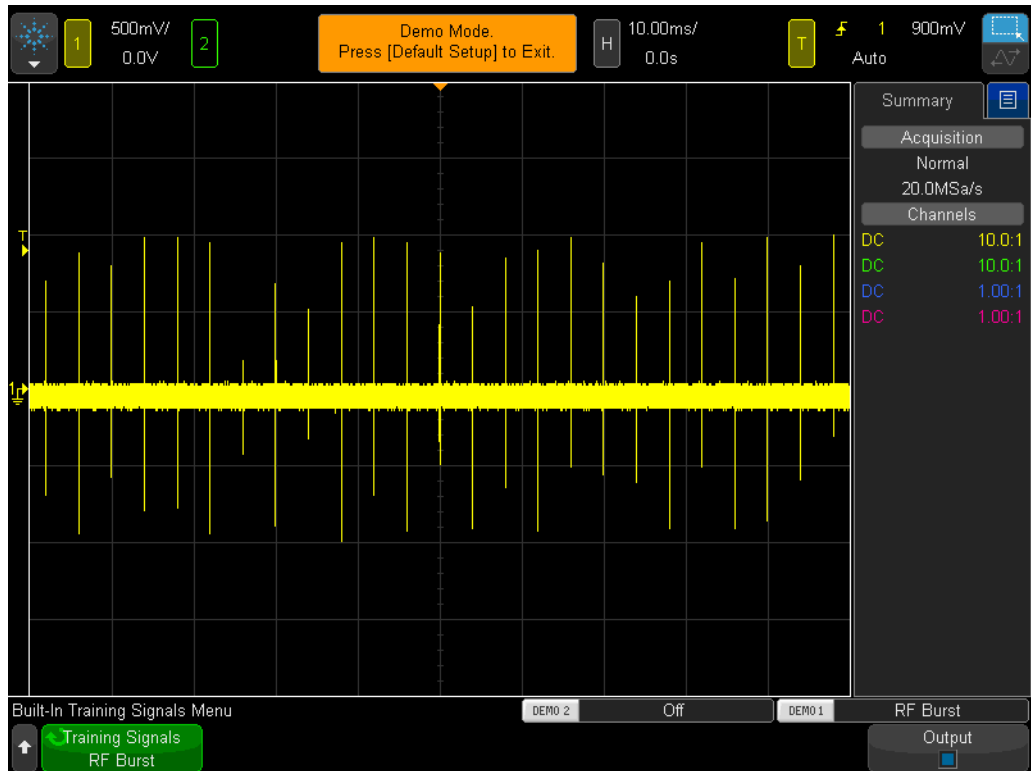

Figure 47 Capturing multiple RF burst waveforms using a slower timebase setting

10 Press **[Run/Stop]** to stop repetitive acquisitions (**[Run/Stop]** key will turn red).

11 Now set the scope's timebase to **200.0 ns/div**.

After acquiring the waveform at the slower timebase setting, and then zooming in, we can clearly see that our waveform was under-sampled as evidenced by the triangular shaped waveforms shown in [Figure 48](#). Remember, this should be a burst of sine waves.

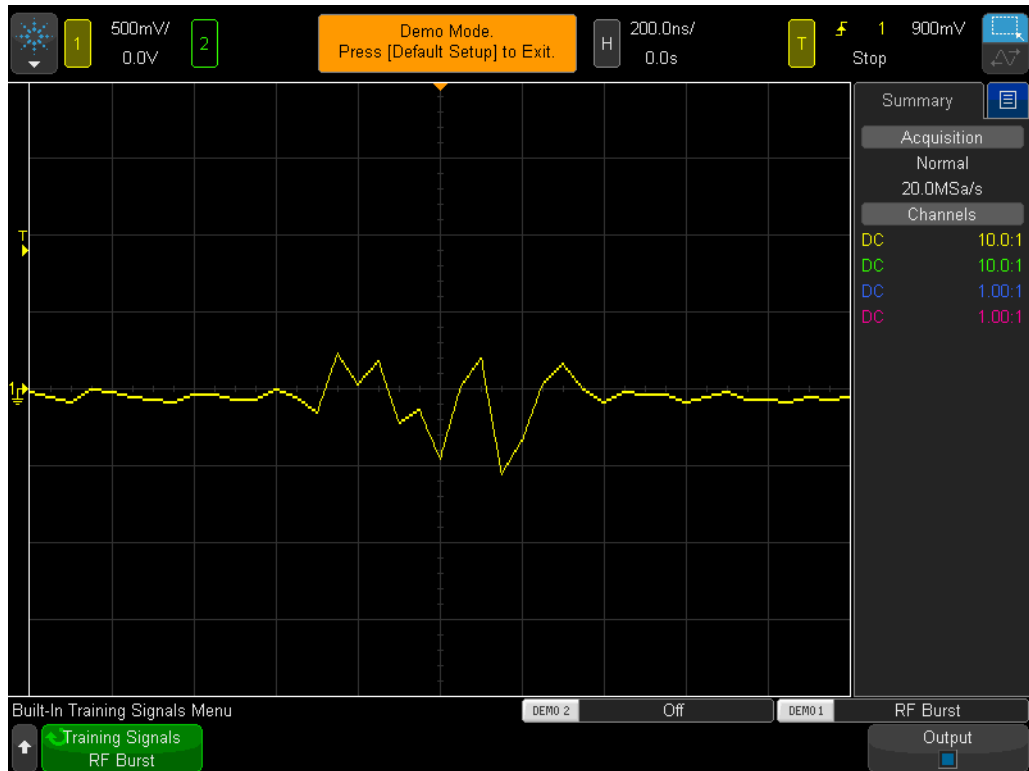

Figure 48 Zooming in reveals an under-sampled waveform

Although using the scope's Peak Detect mode would provide us with a more accurate measure of the peak amplitudes of each burst when captured at the slower timebase setting (Figure 47), we would see that the waveform would still be under-sampled after zooming in on a stored trace. Another solution would be to purchase a scope with much deeper memory. But your university's EE or Physics department may not be able to afford this solution. Let's now use the scope's Segmented Memory acquisition mode to capture multiple bursts with high resolution.

- 12 Press **[Run/Stop]** to begin repetitive acquisitions again with the timebase still set at 200.0 ns/div (**[Run/Stop]** should turn green).
- 13 Press the **[Acquire]** front panel key (near the Cursors knob); then tap the **Segmented** softkey.
- 14 Tap **# of Segs** and set it equal to **25**.
- 15 Now press the **Segmented** softkey to turn on this mode of acquisition.

The scope should have just captured 25 consecutive occurrences of this burst. Let's review them.

- 16 Tap the **Current Seg** softkey; then rotate the **Entry** knob to review all 25 waveforms.

3 Advanced Oscilloscope Measurement Labs

17 Now set the **Current Seg = 25** using the **Entry** knob (last captured segment/waveform).

Along with capturing consecutive low duty cycle signal bursts, the scope also “time-tags” each segment/waveform so that you know the time of each capture segment/waveform relative to the first captured segment/waveform. Time-tags are shown in the lower left-hand corner of the display. Segment #25 should have a time-tag of approximately 96 ms along with a time-of-day stamp as shown in [Figure 49](#). The captured waveform should also have very high resolution since the scope used its maximum sample rate to capture each waveform. If you attempted to capture ~100 ms (10 ms/div) of time-span using the scope’s Normal acquisition mode, the scope would have significantly reduced its sample rate and thereby would have provided extremely poor sample resolution on each burst.

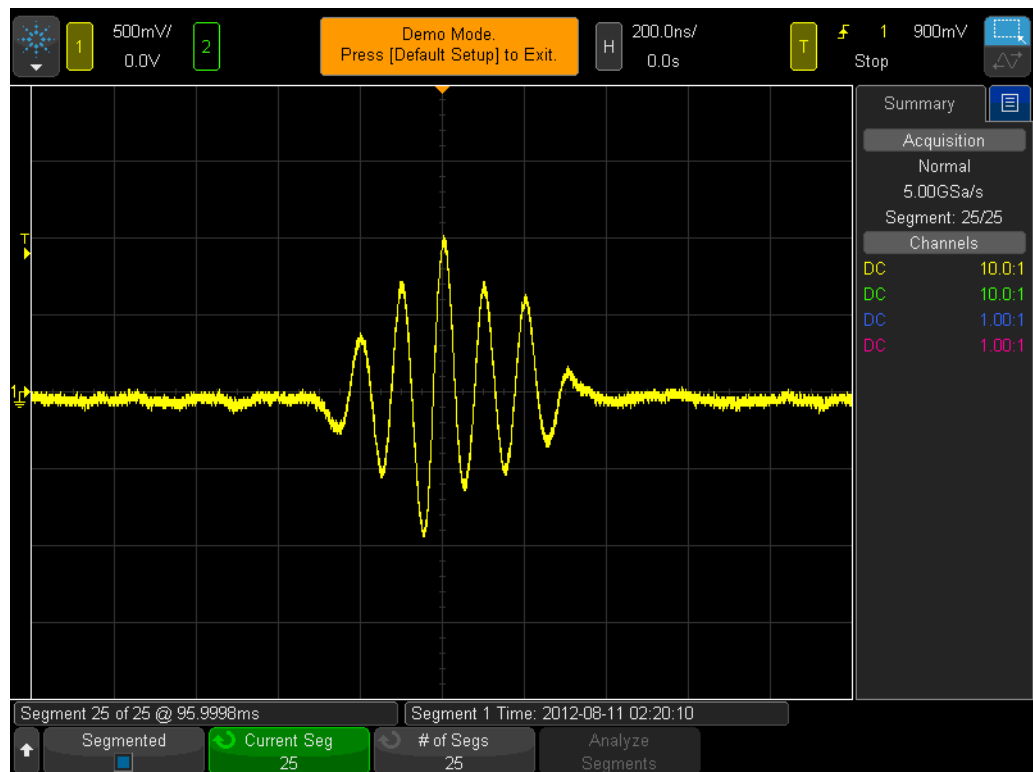

Figure 49 Using Segmented Memory Acquisition to capture more waveforms with high resolution

Segmented Memory acquisition optimizes oscilloscope acquisition memory by only capturing waveform data around small portions (or segments) of a signal (a short sine wave burst in this case). The scope does not capture

unimportant signal dead-time between each burst. Segmented Memory acquisition can also be a very useful tool for capturing multiple serial packets of digital data.

3 Advanced Oscilloscope Measurement Labs



4 Summary

Related Agilent Literature 90

If you have been able to complete all the labs in this oscilloscope lab guide and tutorial, then you should now have a very good understanding of what an oscilloscope is and how to use one proficiently. Not only will this help you to complete your assigned circuits experiments more efficiently and with greater understanding of theoretical EE and Physics concepts, but when you graduate and begin using scopes to verify and test your designs in industry, you will be able to debug your designs faster and get your products to market faster. If you would like to learn more about oscilloscopes and oscilloscope measurements, Agilent provides a broad range of application notes on this topic listed on the next page.



Related Agilent Literature

Table 1 Related Agilent literature

Publication title	Publication type	Publication number
Evaluating Oscilloscope Fundamentals	Application note	5989-8064EN
Evaluating Oscilloscope Bandwidths for your Application	Application note	5989-5733EN
Evaluating Oscilloscope Sample Rates vs. Sampling Fidelity	Application note	5989-5732EN
Evaluating Oscilloscopes for Best Waveform Update Rates	Application note	5989-7885EN
Evaluating Oscilloscope Vertical Noise Characteristics	Application note	5989-3020EN
Evaluating Oscilloscopes for Best Display Quality	Application note	5989-2003EN
Evaluating Oscilloscopes to Debug Mixed-signal Designs	Application note	5989-3702EN
Evaluating Oscilloscope Segmented Memory for Serial Bus Applications	Application note	5990-5817EN

To download these documents, insert the publication number in the URL:
<http://cp.literature.agilent.com/litweb/pdf/xxxx-xxxxEN.pdf>

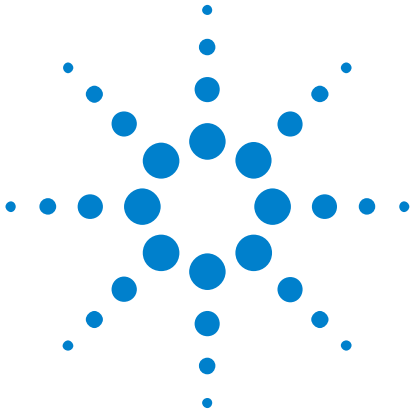

A Oscilloscope Block Diagram and Theory of Operation

DSO Block Diagram	92
ADC Block	92
Attenuator Block	93
DC Offset Block	93
Amplifier Block	93
Trigger Comparator and Trigger Logic Blocks	94
Timebase and Acquisition Memory Blocks	95
Display DSP Block	96



DSO Block Diagram

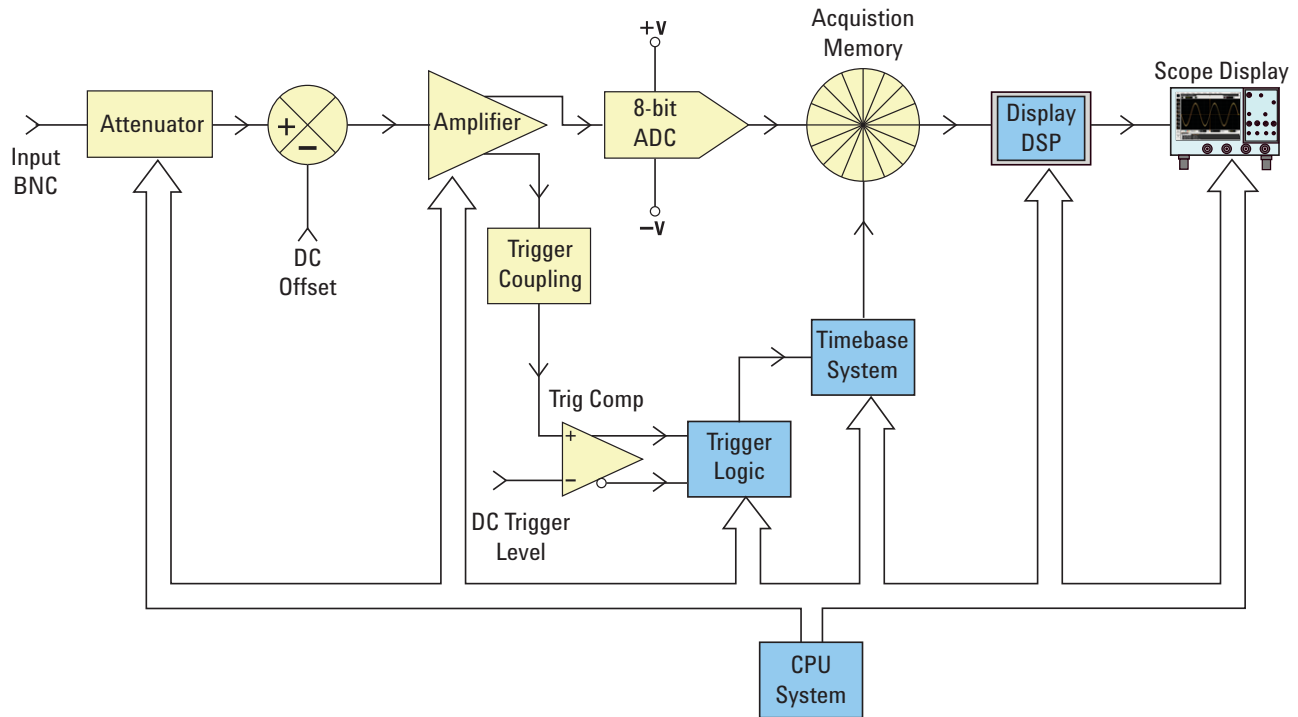

Figure 50 DSO block diagram

Figure 50 shows the block diagram of one channel of acquisition of a typical digital storage oscilloscope (DSO). The yellow-shaded blocks represent system components unique to a single channel of acquisition, such as Channel-1 or Channel-2. The blue-shaded blocks represent system components that are common among all channels of acquisition, such as the scope's common timebase and CPU system.

ADC Block

Shown near the middle of this block diagram is the analog-to-digital convertor (ADC). The ADC block is the core/central component of all DSOs. The function of this block is to convert the analog input into a series of digital words. Most of today's DSOs utilize 8-bit ADCs which will provide 256 unique digital output levels/codes. These digital binary codes are stored in the scope's acquisition memory, which will be discussed later. If the analog input level to the ADC is equal to or less than $-V$, then the output of the ADC will be 00000000 (0 decimal). If the analog input level to the ADC is equal to or greater than $+V$, then the output of the

ADC will be 11111111 (255 decimal). If the analog input level to the ADC is equal to 0.0 V, then the output of the ADC will be 10000000 (128 decimal).

To obtain the highest resolution and accurate measurements, the input to the ADC must be scaled within its dynamic range, which is $\pm V$. Although the ADC has a limited and fixed input dynamic range based on the ADC's reference voltages ($\pm V$), scopes must be able to capture a broad dynamic range of signals including both high level and low level input signals. Scaling the ADC's analog input to be within the ADC's dynamic range is the combined function of attenuator, DC offset, and amplifier blocks, which are discussed next.

Attenuator Block

The attenuator block is basically a network of resistor dividers used to scale the input signal to be within the dynamic range of the scope's variable gain analog amplifier and ADC. When inputting a high level input signal such as 40 V_{pp}, the signal level must be reduced (attenuated). If inputting a low level input signal such as 10 mV_{pp}, then the input signal is passed through to the amplifier with no attenuation (1:1). When you change the scope's V/div setting, you may hear audible clicking sounds. The clicking that you hear are mechanical relays switching-in different resistor divider networks. Note that the attenuator block also includes switching of the user-selectable input impedance (1 M Ω or 50 Ω), as well as AC or DC input coupling.

DC Offset Block

When inputting a signal with DC offset such as a digital signal that swings between 0V to 5V, if we want to display this signal centered on the scope's display, then an internal DC offset of the opposite polarity must be added to the signal in order to shift the input signal to be within the ADC's dynamic range. Alternatively, AC coupling can be selected to eliminate the DC component of the input signal.

Amplifier Block

The final analog processing stage to scale the input signal to be within the dynamic range of the ADC system is the scope's variable gain amplifier. If inputting a very low level input signal, you would typically set the V/div setting to a relatively low setting. With a low V/div setting the attenuator stage would then pass this signal straight through to the amplifier with no attenuation (gain =1), and then the amplifier would boost (gain >1) the amplitude the signal in order to take advantage of the full dynamic range

of the ADC. If inputting a very high level input signal, you would typically set the V/div setting to a relatively high setting. Using a high V/div setting, the attenuator stage would first attenuate the input signal (gain < 1) to get it within the dynamic range of the amplifier, and then the amplifier may further attenuate the signal (gain < 1) to get it within the dynamic range of the ADC.

Note that when you select a specific V/div setting, the scope automatically determines the required amount of attenuation in the attenuator block and the required amount of gain (or possibly additional attenuation) in the amplifier block. You can think of the attenuator block, DC Offset block, and amplifier block as a single block of analog input signal conditioning that linearly conditions a signal that is representative of the input signal to be within the dynamic range of the ADC block based on the V/div and offset setting of that particular channel of the scope.

Trigger Comparator and Trigger Logic Blocks

The purpose of the trigger comparator and trigger logic blocks are to establish a unique point in time on the input signal (or combination of multiple input signals) upon which to establish a synchronized acquisition. After you've completed Lab #2 (Learning the Basics of Oscilloscope Triggering) in this document, you should have a better understanding of what triggering is all about.

Let's assume that your input signal is a sine wave and that you want to trigger acquisitions on the rising edge of the sine wave at the 50% level. In this case the non-inverted output of the trigger comparator would be a square wave with a 50% duty cycle. If you set the trigger level above the 50% level, then the non-inverted output of the trigger comparator would be less than 50%. Alternatively, if you set the trigger level below the 50% level, then the non-inverted output would be greater than 50%. Assuming that triggering is to be based on just a positive edge crossing of a single channel, the trigger logic block would pass the non-inverted output of the trigger comparator to the timebase block. If you have selected to trigger on a negative edge crossing of a single channel, then the trigger logic block would pass the inverted output of the trigger comparator to the timebase block. The timebase block then uses the rising edge of the trigger signal as the unique synchronization point in time. Also note that triggering can be based on many other variables including time-qualification, as well as a combination of input signals from multiple input channels.

Timebase and Acquisition Memory Blocks

The timebase block controls when ADC sampling is started and stopped relative to the trigger event. In addition, the timebase block controls the ADCs sample rate based on the scope's available acquisition memory depth and the timebase setting. For example, let's assume that the scope has been setup to trigger at exactly center screen (default setting) using a timebase setting of 1 ms/div. Let also assume for simplicity that the scope's acquisition memory depth is just 1000 points. Using these assumptions, the scope should acquire 500 points before the trigger event followed by acquiring 500 points after the trigger event. At this timebase setting, the scope will acquire 1000 points across a 10 ms time span (1 ms/div x 10 divisions). Even though the scope's maximum specified sample rate may be 2 GSa/s, at this timebase setting the timebase block will reduce the scope's continuous sample rate to 100 k samples/sec (Sample Rate = Memory/Time-span = 1000 samples/10ms = 100 kSa/s).

When the Run key is pressed, the timebase block enables continuous storing of digitized data into the scope's "circular" acquisition memory at the appropriate sample rate (100 kSa/s). While the timebase block increments addressing of the circular acquisition memory buffer after each sample, it also counts the number of samples taken up to 500 (assuming a memory depth of 1000 and also assuming triggering at center screen). After the timebase block determines that a minimum of 500 samples have been stored (meaning that at least half of the acquisition memory is full), the timebase block then enables triggering and begins to look for the first rising edge of the output trigger comparator (assuming simple edge triggering mode). While looking for the trigger event, acquisitions continue to be stored in the scope's circular acquisition memory buffer. If the trigger event is very infrequent, stored samples can actually be overwritten while waiting on the trigger event. But this is okay. Once the trigger event is detected, the timebase block then begins counting up to 500 again. When an additional 500 samples have been stored, the timebase block then disables (shuts down) sampling. This means that the last 500 stored samples represent sequential points on the waveform that occurred *after* the trigger event, while the previous 500 points represent sequential points on the waveform that occurred *before* the trigger event. At this point operation is turned over to the Display DSP block.

Although we used an example of triggering at center-screen, using the horizontal delay/position control you can position the trigger point at any point. For example, if you adjust the delay such that the trigger point should occur at the 75% point along the horizontal axis (relative to the left side of the screen), then the timebase block would set the counter to initially store 750 points (assuming a memory depth of 1000 points) before enabling the trigger, and then capture an additional 250 points after detection of the trigger event.

Display DSP Block

Once an acquisition is completed, the Display DSP block then backs out the stored data from the acquisition memory block in a last-in-first-out sequence. Not only can the Display DSP block quickly perform digital signal processing on the stored data such as running a $\text{Sin}(x)/x$ digital reconstruction filter, but it can also “pipeline” the stored and/or processed data into the scope’s pixel display memory. After the data has been “backed out” of acquisition memory, the DSP block then signals the timebase block that it can begin another acquisition.

Note that early generations of DSOs did not include an explicit Display DSP block. This function was traditionally handled by the scope’s CPU system, but with much lower efficiency that produced much slower waveform update rates. With custom display DSP processing, some of today’s DSOs can update waveforms as fast as 1,000,000 waveforms/second.

TIP

To learn more about the fundamentals of oscilloscopes, download Agilent’s application note titled *Evaluating Oscilloscope Fundamentals*. This publication is listed in the “[Related Agilent Literature](#)” section of this document with instructions on how to download.

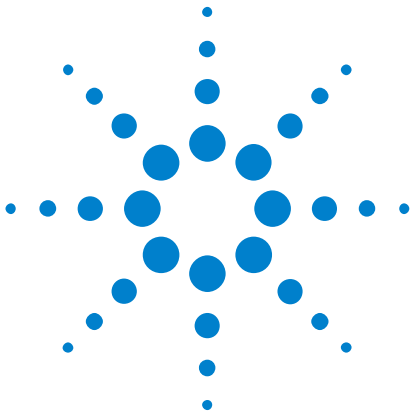

B Oscilloscope Bandwidth Tutorial

Defining Oscilloscope Bandwidth	97
Required Bandwidth for Analog Applications	98
Required Bandwidth for Digital Applications	99
Digital Clock Measurement Comparisons	102

Oscilloscopes have many different specifications that determine the accuracy that signals can be captured and measured. But the primary specification of an oscilloscope is its bandwidth. The oscilloscopes that you are using in your Electrical Engineering undergraduate student labs probably have sufficient bandwidth for most, if not all, of the experiments that your professor will assign. When you finally graduate from your EE program and get into the electronics industry, it is very possible that you will need to either select a scope from an instrument pool at your company to perform testing on your designs, or perhaps you will be tasked with evaluating various oscilloscopes to purchase. This tutorial on oscilloscope bandwidth will provide you some helpful hints on how to select an oscilloscope with the appropriate bandwidth for your digital and analog applications. But first, let's define oscilloscope bandwidth.

Defining Oscilloscope Bandwidth

All oscilloscopes exhibit a low-pass frequency response that rolls-off at higher frequencies as shown in [Figure 51](#). Most scopes with bandwidth specifications of 1 GHz and below typically have what is called a Gaussian frequency response. An oscilloscope Gaussian frequency response approximates a single-pole low-pass filter, which is something you may have already studied about in some of your circuits classes and perhaps graphed as a Bode plot.



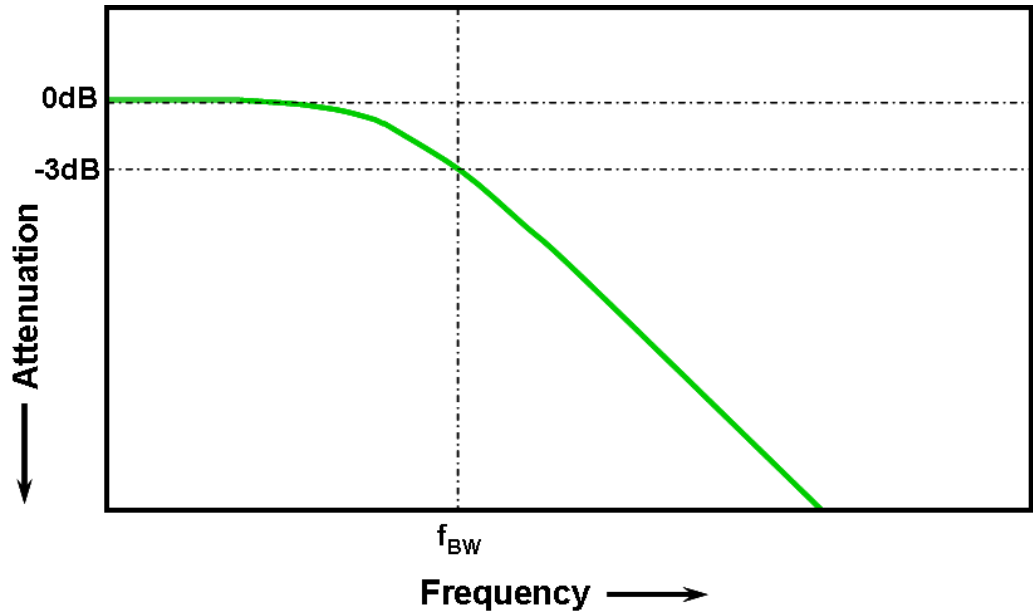

Figure 51 Oscilloscope Gaussian frequency response

The lowest frequency at which the input signal is attenuated by 3 dB is considered the scope’s bandwidth (f_{BW}). Signal attenuation at the -3 dB frequency translates into approximately -30% amplitude error. In other words, if you input a 1 Vp-p, 100 MHz sine wave into a 100 MHz bandwidth oscilloscope, the measured peak-to-peak voltage using this scope would be in the range of approximately 700 mVp-p (-3 dB = $20 \text{ Log } [0.707/1.0]$). So you can’t expect to make accurate measurements on signals that have significant frequencies near your scope’s bandwidth.

Closely related to an oscilloscope’s bandwidth specification is its rise time specification. Scopes with a Gaussian-type frequency response will have an approximate rise time of $0.35/f_{BW}$ based on a 10% to 90% criterion. But you need to remember that a scope’s rise time is not the fastest edge speed that the oscilloscope can accurately measure. It is the fastest edge speed the scope can possibly produce if the input signal has a theoretical infinitely fast rise time (0 ps). Although this theoretical specification is impossible to test – since pulse generators don’t have infinitely fast edges – from a practical perspective, you can test your oscilloscope’s rise time by inputting a pulse that has edge speeds that are 5 to 10 times faster than the scope’s rise time specification.

Required Bandwidth for Analog Applications

Years ago, most oscilloscope vendors recommended that your scope’s bandwidth should be at least three times higher than the maximum input signal frequency. And this rule-of-thumb recommendation may be what

your professor remembers. Although this “3X” multiplying factor would not apply to digital applications based on clock rates or edge speeds, it still applies to analog applications, such as modulated RF. To understand where this 3-to-1 multiplying factor comes from, let’s look at an actual frequency response of a 1 GHz bandwidth scope.

Figure 52 shows a measured frequency response test (1 MHz to 2 GHz) on an Agilent 1 GHz bandwidth oscilloscope. As you can see, at exactly 1 GHz the measured output (waveform on oscilloscope display) is attenuated by slightly less than 3 dB ($V_o/V_i > 0.7$). To make accurate measurements on analog signals, you would need to use the scope in the portion of the frequency band where it is still relatively flat with minimal attenuation. At approximately one-third the scope’s 1 GHz bandwidth, this scope exhibits very little attenuation (-0.2 dB).

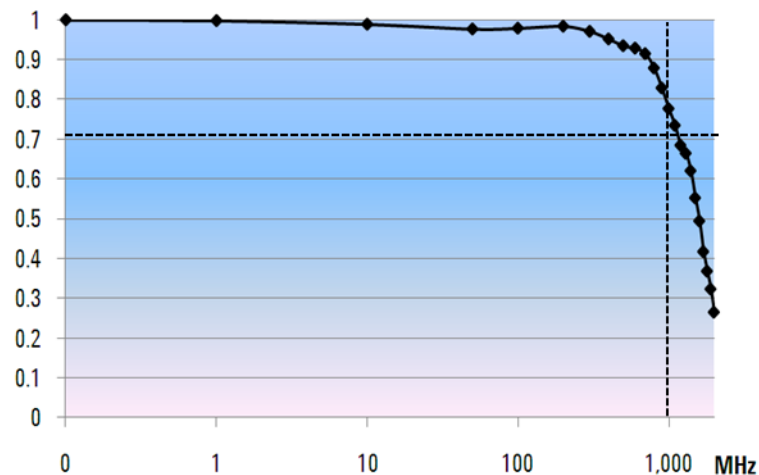

Figure 52 Actual frequency response of an Agilent 1 GHz bandwidth oscilloscope

Required Bandwidth for Digital Applications

The vast majority of today’s EE graduates will be focused on digital design applications when they enter the electronics industry. And digital clock rates and serial data links in the multi-Giga bits/sec range are very common today.

Rule of Thumb

As a rule of thumb, your scope's bandwidth should be at least five times higher than the fastest digital clock rate in your system under test. If your scope meets this criterion, then it will be able to capture up to the fifth harmonic with minimum signal attenuation. This component of the signal is very important in determining the overall shape of your digital signals.

$$f_{BW} \geq 5 \times f_{clk}$$

But if you need to make accurate measurements on high-speed edges, this simple formula does not take into account the actual highest-frequency components embedded in fast rising and falling edges.

Step 1: Determine fastest actual edge speeds

A more accurate method to determine required oscilloscope bandwidth is to ascertain the maximum frequency present in your digital signals, which is not the maximum clock rate. The maximum frequency will be based on the fastest edge speeds in your designs. So the first thing you need to do is determine the rise and fall times of your fastest signals. You can usually obtain this information from published specifications for devices used in your designs.

Step 2: Calculate f_{knee}

You can then use a simple formula to compute the maximum “practical” frequency component. Dr. Howard W. Johnson has written a book on this topic, *“High-speed Digital Design – A Handbook of Black Magic.”*¹ He refers to this frequency component as the “knee” frequency (f_{knee}). All fast edges have an infinite spectrum of frequency components. However, there is an inflection (or “knee”) in the frequency spectrum of fast edges where frequency components higher than f_{knee} are insignificant in determining the shape of the signal.

$$f_{knee} = 0.5/RT \text{ (10\% 90\%)}$$
$$f_{knee} = 0.4/RT \text{ (20\% 80\%)}$$

For signals with rise time characteristics based on 10% to 90% thresholds, f_{knee} is equal to 0.5 divided by the rise time of the signal. For signals with rise time characteristics based on 20% to 80% thresholds, which is very common in many of today's device specifications, f_{knee} is equal to 0.4

divided by the rise time of the signal. Now don't confuse these rise times with a scope's specified rise time. We are talking about actual signal edge speeds.

Step 3: Calculate scope bandwidth

The third step is to determine the oscilloscope bandwidth required to measure this signal, based on your desired degree of accuracy when measuring rise times and fall times. Table 2 shows multiplying factors for various degrees of accuracy for scopes with a Gaussian frequency response.

Table 2 Multiplying factors to calculate required scope bandwidth based on desired accuracy

Required Accuracy	Require Bandwidth
20%	$f_{BW} = 1.0 \times f_{knee}$
10%	$f_{BW} = 1.3 \times f_{knee}$
3%	$f_{BW} = 1.9 \times f_{knee}$

Example

Let's now walk through this simple example:

Determine the minimum required bandwidth of an oscilloscope with an approximate Gaussian frequency response to measure a 1 ns rise time (10-90%)

If the signal has an approximate rise/fall time of 1 ns (based on a 10% to 90% criteria), then the maximum practical frequency component (f_{knee}) in the signal would be approximately 500 MHz.

$$f_{knee} = 0.5/1 \text{ ns} = 500 \text{ MHz}$$

If you are able tolerate up to 20% timing errors when making parametric rise time and fall time measurements on your signals, then you could use a 500 MHz bandwidth oscilloscope for your digital measurement applications. But if you need timing accuracy in the range of 3%, then a scope with 1 GHz bandwidth would be the better choice.

20% timing accuracy:
Scope bandwidth = 1.0 x 500 MHz = 500 MHz

3% timing accuracy:
Scope bandwidth = 1.9 x 500 MHz = 950 MHz

Let's now make some measurements on a digital clock signal with characteristics similar to this example, using various bandwidth scopes....

Digital Clock Measurement Comparisons

Figure 53 shows the waveform results when measuring a 100 MHz digital clock signal with fast edge speeds using a 100 MHz bandwidth oscilloscope. As you can see, this scope primarily just passes through the 100 MHz fundamental of this clock signal, thus representing our clock signal as an approximate sine wave. A 100 MHz scope may be a good solution for many 8-bit, MCU-based designs with clock rates in the 10 MHz to 20 MHz range, but 100 MHz bandwidth is clearly insufficient for this 100 MHz digital clock signal.

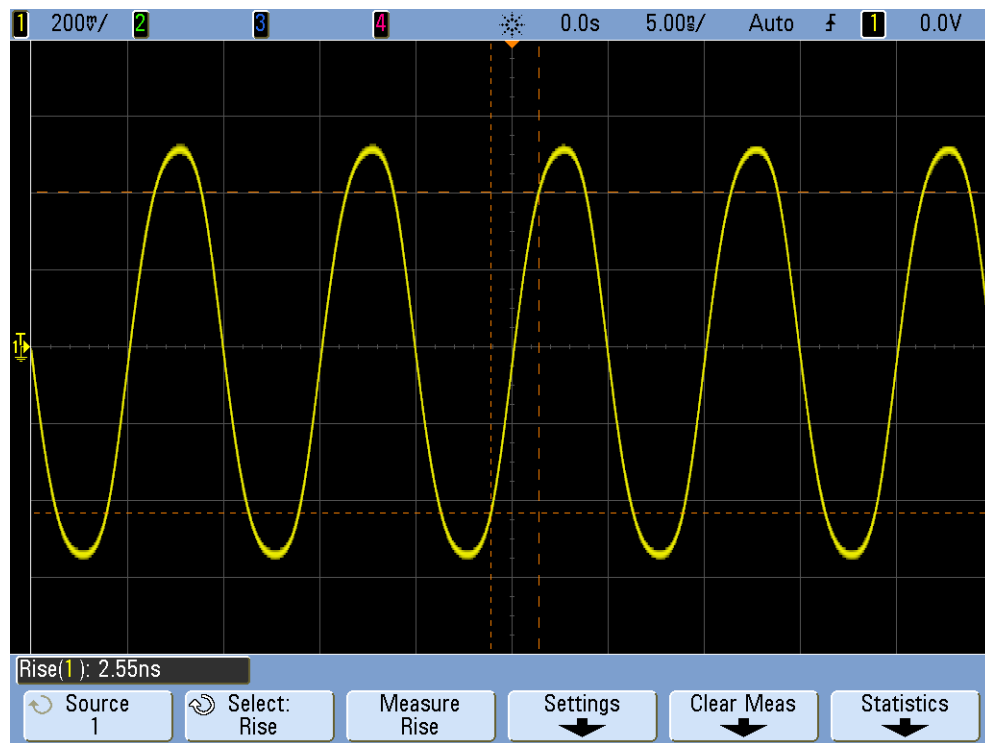

Figure 53 100 MHz digital clock signal captured on a 100 MHz bandwidth scope

Using a 500 MHz bandwidth oscilloscope, [Figure 54](#) shows that this scope is able to capture up to the fifth harmonic, which was our first rule of thumb recommendation. But when we measure the rise time, we see that the scope measures approximately 750 ps. In this case, the scope is not making a very accurate measurement on the rise time of this signal. The scope is actually measuring something closer to its own rise time (700 ps), not the input signal's rise time, which is closer to 500 ps. We need a higher-bandwidth scope for this digital measurement application if timing measurements are important.

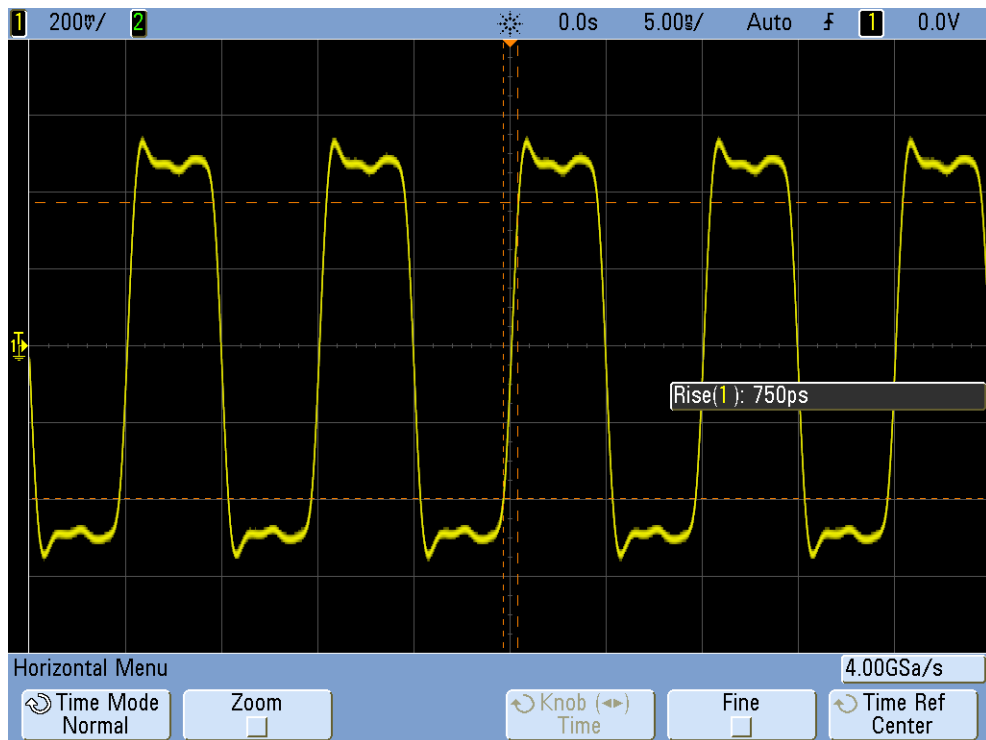

Figure 54 100 MHz digital clock signal captured on a 500 MHz bandwidth scope

When we use a 1 GHz bandwidth scope to capture this 100 MHz digital clock, the result is that we now have a much more accurate picture of this signal, as shown in [Figure 55](#). We can measure faster rise and fall times, we observe less overshoot, and we can even observe subtle reflections that the lower bandwidth scope masked.

B Oscilloscope Bandwidth Tutorial

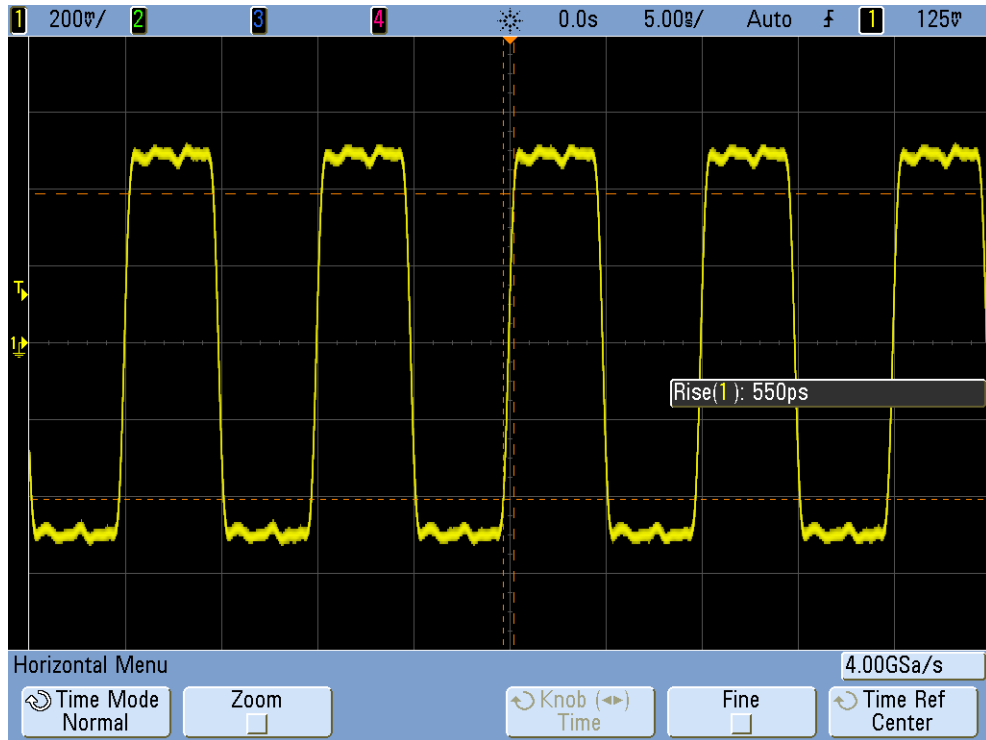

Figure 55 100 MHz digital clock signal captured on a 1 GHz bandwidth scope

This tutorial on oscilloscope bandwidth focused on oscilloscopes that exhibit a Gaussian frequency response, which is typical of scopes that have bandwidth specifications of 1 GHz and below. Many higher bandwidth oscilloscopes exhibit a frequency response that has a sharper roll-off characteristic. With this type of frequency response, in-band frequencies (frequencies below the -3 dB frequency) are attenuated less, while out-of-band frequencies (frequencies above the -3 dB frequency) are suppressed to a higher degree. This type of frequency response, which begins to approximate an ideal “brick-wall” filter, is sometimes called a “maximally-flat” frequency response. The formulas for computing required oscilloscope bandwidth on these higher bandwidth scopes (> 1 GHz) are different than what was presented in this tutorial guide. If you would like to learn more about oscilloscope bandwidth, you can download Agilent’s application note title, “*Evaluating Oscilloscope Bandwidths for your Application*”. This publication is listed in the “Related Literature” section of this document with instructions on how to download.

¹ High-Speed Digital Design, A Handbook of Black Magic, Howard Johnson, Martin Graham, 1993, Prentice Hall PTD, Prentice-Hall, Inc, Upper Saddle River, New Jersey 07458

Index

A

acquisition memory, 78
adjustment, probe compensation, 41
analog scopes, 7
Auto Trigger mode, 27
auto triggering, 26
auto-increment, 35
automatic parametric measurement, 59
Averaging acquisition mode, 32

B

burst, 48

C

compensation capacitance, 42
compensation, probe, 40
cursors, 20

D

delay/position, 24
Delayed Sweep timebase mode, 67
differential active probe, 9
digital pulse parameter measurements, 61
digital storage oscilloscope, 7
division counting, 21
DSO, 7
DSOXEDK, 3
dynamic range, 10

E

Educator's Training Kit (DSOXEDK), 3
electrical model of a 10
1 passive probe, 9
Entry control knob, 13

F

Fall Time measurement, 61
FFT math function, 76
frequency, 19
frequency domain waveform, 76
function generators, 45

G

gated measurements, 65

glitch triggering, 52

H

high frequency reject, 30
hold-off, trigger, 48
Horizontal controls, 11

I

image, saving, 34
infinite persistence, 53
inherent/parasitic capacitance, 39
introduction, 3

L

Lissajous curve, 72
literature, related Agilent, 90
loading capacitance, 44

M

math operations on waveforms, 74
maximum of waveform, 61
measurement threshold levels, 62
measurement, automatic parametric, 59
mixed signal oscilloscope, 7
MSO, 7

N

noise reject, 31
Normal Trigger mode, 27
Normal trigger mode for single-shot, 56
Note to the EE/Physics Professor, 4
notices, 2
Nyquist Sampling theorem, 80

O

oscilloscope, 7
oscilloscope probing, 9

P

parametric measurement, automatic, 59
parasitic capacitances, 39
passive 10
1 voltage probes, 9
Peak Detect mode, 79

peak-to-peak voltage level, 19
period, 19
persistence, infinite, 53
phase delay measurements, 70
phase shift, 72, 74
probe compensation, 40
probe loading, 43
probing, oscilloscope, 9
Pulse Width triggering mode, 52

R

Reference Waveform data file, 36
Rise Time measurement, 61

S

save image, 34
save setup, 34
save waveform, 34
Segmented Memory acquisition mode, 85
setup, saving, 34
single-shot event, 56
Snapshot-All measurement, 63
softkeys, 12

T

threshold levels for measurements, 61
time domain waveform, 76
top of waveform, 61
trademarks, 2
trigger hold-off, 48
trigger hysteresis, 31
trigger level control/knob, 12
trigger sensitivity, 31
trigger time point, 24
triggering, 23

V

Vertical controls, 11
voltage threshold levels, 61

W

waveform intensity level, 13
waveform math, 74
waveform, saving, 34

Index

Z

zoom timebase, [67](#)