

# Keysight E3620A Dual Output Power Supply



NOTICE: This document contains references to Agilent Technologies. Agilent's former Test and Measurement business has become Keysight Technologies. For more information, go to [www.keysight.com](http://www.keysight.com).



## **CERTIFICATION**

*Keysight Technologies certifies that this product met its published specifications at time of shipment from the factory. Keysight Technologies further certifies that its calibration measurements are traceable to the United States National Institute of Standards and Technology (formerly National Bureau of Standards), to the extent allowed by that organization's calibration facility, and to the calibration facilities of other International Standards Organization members.*

## **WARRANTY**

This Keysight Technologies hardware product is warranted against defects in material and workmanship for a period of 3 years from date of delivery. Keysight software and firmware products, which are designated by Keysight for use with a hardware product and when properly installed on that hardware product, are warranted not to fail to execute their programming instructions due to defects in material and workmanship for a period of 90 days from date of delivery. During the warranty period, either Keysight or Keysight Technologies will, at its option, either repair or replace products which prove to be defective. Keysight does not warrant that operation the software, firmware, or hardware shall be uninterrupted or error free.

For warranty service, with the exception of warranty options, this product must be returned to the nearest service center designated by Keysight. Customer shall prepay shipping charges by (and shall pay all duty and taxes) for products returned to Keysight for warranty service. Except for the products returned to Customer from another country, Keysight shall pay for return of products to Customer.

Warranty services outside the country of initial purchase are included in Keysight's product price, only if Customer pays Keysight international prices (defined as destination local currency price, or U.S. or Geneva Export price).

If Keysight is unable, within a reasonable time, to repair or replace any product to condition as warranted, the Customer shall be entitled to a refund of the purchase price upon return of the product to Keysight.

The warranty period begins on the date of delivery or on the date of installation if installed by Keysight.

## **LIMITATION OF WARRANTY**

The foregoing warranty shall not apply to defects resulting from improper or inadequate maintenance by the Customer, Customer-supplied software or interfacing, unauthorized modification or misuse, operation outside of the environmental specifications for the product, or improper site preparation and maintenance. TO THE EXTENT ALLOWED BY LOCAL LAW, NO OTHER WARRANTY IS EXPRESSED OR IMPLIED. AND KEYSIGHT SPECIFICALLY DISCLAIMS THE IMPLIED WARRANTIES OF MERCHANTABILITY AND FITNESS FOR A PARTICULAR PURPOSE.

*For consumer transactions in Australia and New Zealand:*

The warranty terms contained in this statement, except to the extent lawfully permitted, do not exclude, restrict or modify and are in addition to the mandatory rights applicable to the sale of this product to you.

## **EXCLUSIVE REMEDIES**

TO THE EXTENT ALLOWED BY LOCAL LAW, THE REMEDIES PROVIDED HEREIN ARE THE CUSTOMER'S SOLE AND EXCLUSIVE REMEDIES. KEYSIGHT SHALL NOT BE LIABLE FOR ANY DIRECT, INDIRECT, SPECIAL, INCIDENTAL, OR CONSEQUENTIAL DAMAGES, WHETHER BASED ON CONTRACT, TORT, OR ANY OTHER LEGAL THEORY.

## **ASSISTANCE**

*The above statements apply only to the standard product warranty. Warranty options, extended support contacts, product maintenance agreements and customer assistance agreements are also available. Contact your nearest Keysight Technologies Sales and Service office for further information on Keysight's full line of Support Programs.*

## SAFETY SUMMARY

*The following general safety precautions must be observed during all phases of operation, service, and repair of this instrument. Failure to comply with these precautions or with specific warnings elsewhere in this manual violates safety standards of design, manufacture, and intended use of the instrument. Keysight Technologies assumes no liability for the customer's failure to comply with these requirements.*

### BEFORE APPLYING POWER.

Verify that the product is set to match the available line voltage and that the correct fuse is installed.

### GROUND THE INSTRUMENT.

This product is a Safety Class I instrument (provided with a protective earth terminal). To minimize shock hazard, the instrument chassis and cabinet must be connected to an electrical ground. The instrument must be connected to the AC power supply mains through a three-conductor power cable, with the third wire firmly connected to an electrical ground(safety ground) at the power outlet. Any interruption of the protective(grounding) conductor or disconnection of the protective earth terminal will cause a potential shock hazard that could result in personal injury. If the instrument is to be energized via an external autotransformer for voltage reduction, be certain that the autotransformer common terminal is connected to the neutral(earthed pole) of the AC power lines (supply mains).

### DO NOT OPERATE IN AN EXPLOSIVE ATMOSPHERE.

Do not operate the instrument in the presence of flammable gases or fumes.

### KEEP AWAY FROM LIVE CIRCUITS.

Operating personnel must not remove instrument covers. Component replacement and internal adjustments must be made by qualified service personnel. Do not replace components with power cable connected. Under certain conditions, dangerous voltages may exist even with the power cable removed. To avoid injuries, always disconnect power, discharge circuits and remove external voltage sources before touching components.

### DO NOT SERVICE OR ADJUST ALONE.

Do not attempt internal service or adjustment unless another person, capable of rendering first aid and resuscitation, is present.

### SAFETY SYMBOLS



Caution, risk of danger (refer to this manual for specific Warning or Caution information)



Direct current (DC)



Alternating current (AC)



Protective conductor terminal



Out position of a bi-stable push control



In position of a bi-stable push control



Earth (ground) terminal



Positive binding post



Negative binding post



Frame or chassis terminal



The WARNING sign denotes a hazard. It calls attention to a procedure, practice, or the like, which, if not correctly performed or adhered to, could result in personal injury. Do not proceed beyond a WARNING sign until the indicated conditions are fully understood and met.



The CAUTION sign denotes a hazard. It calls attention to an operating procedure, or the like, which, if not correctly performed or adhered to, could result in damage to or destruction of part or all of the product. Do not proceed beyond CAUTION sign until the indicated conditions are fully understood and met.



The NOTE sign denotes important information. It calls attention to a procedure, practice, condition or the like, which is essential to highlight.

### DO NOT SUBSTITUTE PARTS OR MODIFY INSTRUMENT.

Because of the danger of introducing additional hazards, do not install substitute parts or perform any unauthorized modification to the instrument. Return the instrument to a Keysight Technologies Sales and Service Office for service and repair to ensure that safety features are maintained.

*Instruments that appear damaged or defective should be made inoperative and secured against unintended operation until they can be repaired by qualified service personnel.*

## REGULATORY MARKINGS



The CE marking is a legal compliance marking of the European Community. This CE marking shows that the product complies with all the relevant European Legal Directives.



The CSA mark is a registered trademark of the Canadian Standards Association.



The C-tick mark is a registered trademark of the Spectrum Management Agency of Australia. This signifies compliance with the Australia EMC Framework regulations under the terms of the Radio Communication Act of 1992.



This symbol indicates the time period during which no hazardous or toxic substance elements are expected to leak or deteriorate during normal use. Forty years is the expected useful life of the product.

**ICES/NMB-001**

ICES/NMB-001 indicates that this ISM device complies with the Canadian ICES-001. Cet appareil ISM est conforme a la norme NMB-001 du Canada.



This symbol is a South Korean Class A EMC Declaration. This is a Class A instrument suitable for professional use and in electromagnetic environment outside of the home.



This instrument complies with the WEEE Directive (2002/96/EC) marking requirement. This affixed product label indicates that you must not discard this electrical or electronic product in domestic household waste.

## DECLARATION OF CONFORMITY

The Declaration of Conformity (DoC) for this instrument is available on the Keysight Web site. You can search for the DoC by its product model or description at the web address below.

<http://www.keysight.com/go/conformity>

<b>NOTE</b>
-------------

If you are unable to search for the respective DoC, please contact your local Keysight representative.

# TABLE OF CONTENTS

<b>SAFETY SUMMARY</b> .....	<b>1-3</b>
<b>REGULATORY MARKINGS</b> .....	<b>1-4</b>
<b>DECLARATION OF CONFORMITY</b> .....	<b>1-5</b>
<b>GENERAL INFORMATION</b> .....	<b>1-8</b>
DESCRIPTION .....	1-8
SAFETY CONSIDERATIONS .....	1-8
SAFETY AND EMC REQUIREMENTS .....	1-8
INSTRUMENT AND MANUAL IDENTIFICATION .....	1-8
OPTIONS .....	1-8
ACCESSORY .....	1-8
SPECIFICATIONS .....	1-8
LINE FUSE .....	1-9
<b>INSTALLATION</b> .....	<b>1-9</b>
INITIAL INSPECTION .....	1-9
Mechanical Check .....	1-9
Electrical Check .....	1-9
INSTALLATION DATA .....	1-9
Location and Cooling .....	1-9
Outline Diagram .....	1-10
Rack Mounting .....	1-10
INPUT POWER REQUIREMENTS .....	1-10
Power Cable .....	1-10
<b>OPERATING INSTRUCTIONS</b> .....	<b>1-10</b>
INTRODUCTION .....	1-10
CONTROLS .....	1-10
Line Switch .....	1-10
Voltage and Current Metering .....	1-10
Voltage Controls .....	1-10
TURN-ON CHECKOUT PROCEDURE .....	1-11
OPERATION .....	1-11
Overload Protection Circuits .....	1-11
Operation Beyond Rated Output .....	1-11
Connecting Load .....	1-11
Series Operation .....	1-11
Parallel Operation .....	1-11
<b>LOAD CONSIDERATIONS</b> .....	<b>1-12</b>
PULSE LOADING .....	1-12
REVERSE CURRENT LOADING .....	1-12
OUTPUT CAPACITANCE .....	1-12
REVERSE VOLTAGE PROTECTION .....	1-12
<b>SERVICE INFORMATION</b> .....	<b>A-1</b>
MAINTENANCE .....	A-1
MAINTENANCE .....	A-1
INTRODUCTION .....	A-1
PERFORMANCE TESTS .....	A-2



TROUBLESHOOTING .....	A-5
ADJUSTMENT AND CALIBRATION .....	A-5
COMPONENT LOCATOR DIAGRAMS .....	A-7
MAIN BOARD — TOP .....	A-7
MAIN BOARD — BOTTOM .....	A-8
DISPLAY CONTROLLER — TOP .....	A-9
DISPLAY CONTROLLER — BOTTOM .....	A-10
7-SEGMENT — TOP .....	A-11
7-SEGMENT — BOTTOM .....	A-12

## GENERAL INFORMATION

### DESCRIPTION

The Model E3620A Dual Output Power Supply is a compact, constant voltage/current limiting supply that delivers two isolated 0 to 25 V outputs rated at 1 A. It is an ideal power supply for design and breadboard work where single or dual voltages are required. Each output voltage is continuously variable throughout its range and separate current limit circuits protect each output against overload or short circuit damage.

Connections to the outputs are made to binding post type terminals on the front panel. The outputs can be used individually or in combination to satisfy any number of output demands. The positive or negative terminal of each output can be grounded or each output can be left floating. A chassis ground terminal is located on the front panel of the supply.

The front panel also contains a line switch, output voltage controls, an autoranging digital voltmeter and a single-range digital ammeter, and two meter select pushbutton switches. The meter pushbuttons select both voltage and current monitoring for the output V1 and V2. The supply is furnished with a detachable, 3-wire grounding type line cord. The AC line fuse is an extractor type fuseholder on the rear heat sink.

### SAFETY CONSIDERATIONS

This product is a Safety Class I instrument, which means that it is provided with a protective earth ground terminal. This terminal must be connected to an AC source that has a 3-wire ground receptacle. Review the instrument rear panel and this manual for safety markings and instructions before operating the instrument. Refer to the Safety Summary page at the beginning of this manual for a summary of general safety information. Specific safety information is located at the appropriate places in this manual.

### SAFETY AND EMC REQUIREMENTS

This power supply is designed to comply with the following safety and EMC(Electromagnetic Compatibility) requirements

#### Safety

- IEC 61010-1:2010 / EN 61010-1:2010
- CAN/CSA-C22.2 No. 61010.1-12

#### EMC

- IEC 61326-1:2005/EN61326-1:2006
- CISPR11:2003/EN55011:2007
- Canada: ICES/NMB-001:Issue 4, June 2006
- Australia/New Zealand: AS/NZS CISPR 11:2004

## INSTRUMENT AND MANUAL IDENTIFICATION

A serial number identifies your power supply. The serial number encodes the country of manufacture, the week of the latest significant design change, and a unique sequential number. The letter "KR" or "MY" designates Korea or Malaysia as the country of manufacture respectively. For Korea, the first one digit indicates the year (4=1994, 5=1995, and so forth), and the second two digits indicate the week. For Malaysia, the first two digits indicate Keysight year and the second two digits indicate the work-week. The remaining digits of the serial number are a unique, five-digit number (Korea) or four-digit number (Malaysia) assigned sequentially.

If a yellow Change Sheet is supplied with this manual, its purpose is to explain any differences between your instrument and the instrument described in this manual. The Change Sheet may also contain information for correcting errors in the manual.

### OPTIONS

Options 0EM, 0E3, and 0E9 determine which line voltage is selected at the factory. The standard unit is configured for 115 VAC  $\pm$  10%, 47-63 Hz input.

Option No.	Description
0EM:	115 VAC $\pm$ 10%, 47-63 Hz Input
0E3:	230 VAC $\pm$ 10%, 47-63 Hz Input
0E9:	100 VAC $\pm$ 10%, 47-63 Hz Input

### ACCESSORY

The accessory listed below may be ordered from your local Keysight Technologies Sales Office either with the power supply or separately. (Refer to the list at the rear of the manual for address.)

#### Keysight Part No. Description

5063-9240	Rack Kit for mounting one or two 3 1/2" high supplies in a standard 19" rack
-----------	--

The rack mount kit is needed for rack mounting of the E3620A power supply.

### SPECIFICATIONS

Instrument specifications are listed in Table 1. These specifications are performance standards or limits against which the instrument is tested.

## LINE FUSE

The line fuse is located by the AC line receptacle. Check the rating of the line fuse and replace it with the correct fuse if necessary as indicated below. These are slow-blow fuses.

Line Voltage	Fuse	Keysight Part No.
100/115 VAC	2 A	2110-0702
230 VAC	1 A	2110-0457

Table 1. Specifications

### WARRANTED SPECIFICATIONS

#### DC OUTPUT

Voltage span over which output may be varied using front panel controls.

Output V1: 0 to 25 V at 1 A

Output V2: 0 to 25 V at 1 A

#### LOAD REGULATION

Less than 0.01% plus 2 mV for a full load to no load change in output current.

#### LINE REGULATION

Less than 0.01% plus 2 mV for any line voltage change within rating.

#### RIPPLE AND NOISE

Normal Mode Voltage: Less than 0.35 mVrms/1.5 mV p-p (20 Hz-20 MHz).

Common Mode Current (CMI): Less than 1  $\mu$ Arms for all outputs (20 Hz-20 kHz).

#### OPERATING TEMPERATURE RANGE

0 to 40 °C for full rated output. At higher temperatures, output current is derated linearly to 50% at 55 °C maximum temperature.

#### OPERATING ALTITUDE

Up to 2000 m

#### STORAGE TEMPERATURE RANGE

-20 °C to 70 °C

#### HUMIDITY

Up to 80% RH

#### LOAD TRANSIENT RESPONSE TIME

Less than 50  $\mu$ sec for output recovery to within 15 mV of nominal output voltage following a load change from full load to half load, or vice versa.

**METER ACCURACY:**  $\pm(0.5\%$  of output + 2 counts)

#### METER RESOLUTION

Voltage: 10 mV (0 to 20 V), 100 mV (above 20 V)

Current: 1 mA

at 25 °C  $\pm 5$  °C

### TYPICAL (SUPPLEMENTAL) SPECIFICATIONS

#### TEMPERATURE COEFFICIENT

Less than 0.02% plus 1 mV voltage change per °C over the operating range from 0 to 40 °C after 30 minutes warm-up.

#### STABILITY (OUTPUT DRIFT)

Less than 0.1% plus 5 mV (DC to 20 Hz) during 8 hours at constant line, load and ambient after an initial warm-up time of 30 minutes.

#### OUTPUT VOLTAGE OVERSHOOT

During turn-on or turn-off of AC power, output plus overshoot will not exceed 1 V if the output control is set for less than 1 V. If the control is set for 1 V or higher, there is no overshoot.

### GENERAL SPECIFICATIONS

#### AC INPUT

0EM: 115 VAC  $\pm 10\%$ , 47-63 Hz, 200 VA, 130 W

0E9: 100 VAC  $\pm 10\%$ , 47-63 Hz, 200 VA, 130 W

0E3: 230 VAC  $\pm 10\%$ , 47-63 Hz, 200 VA, 130 W

#### DIMENSIONS

212.3 mmW x 88.1 mmH x 345.4 mmD

(8.4 inW x 3.5 inH x 13.6 inD)

#### WEIGHT

5.0 kg (11.0 lbs) net, 6.25 kg (13.8 lbs) shipping

This instrument is Intended for Indoor use.

## INSTALLATION

### INITIAL INSPECTION

Before shipment, this instrument was inspected and found to be free of mechanical and electrical defects. As soon as the instrument is unpacked, inspect for any damage that may have occurred in transit. Save all packing materials until the inspection is completed. If damage is found, a claim should be filed with the carrier. The Keysight Technologies Sales and Service office should be notified as soon as possible.

### Mechanical Check

This check should confirm that there are no broken knobs or connectors, that the cabinet and panel surfaces are free of dents and scratches, and that the meter is not scratched or cracked.

### Electrical Check

This instrument should be checked against electrical specifications. Perform the TURN-ON CHECKOUT PROCEDURE in the following paragraph to confirm that the supply is operational. Alternately, check the supply more fully using the PERFORMANCE TEST in the service information section.

### INSTALLATION DATA

The instrument is shipped ready for bench operation. Before applying power to the supply, please read the INPUT POWER REQUIREMENTS paragraph.

### Location and Cooling

This instrument is air cooled. Sufficient space should be allowed so that a free flow of cooling air can reach the sides and rear of the instrument when it is in operation. It should be used in an area where the ambient temperature does not exceed 40 °C.

## Outline Diagram

Figure 1 illustrates the outline shape and dimensions of the supply.

## Rack Mounting

This supply may be rack mounted in a standard 19-inch rack panel either by itself or alongside a similar unit. Please see the ACCESSORY, page 1-8, for available rack mounting accessory. The rack-mounting kit includes complete installation instructions.

## INPUT POWER REQUIREMENTS

Depending on the line voltage option ordered, the supply is ready to be operated from one of the power sources listed in Table 1. A label on the rear heat sink shows the nominal input voltage set for the supply at the factory.

## Power Cable

To protect operating personnel, the supply should be grounded. This supply is equipped with a three conductor power cable. The third conductor is the ground conductor and when the cable is plugged into an appropriate receptacle, the supply is grounded. The power supply is equipped at the factory with a power cord plug appropriate for the user's location. Notify the nearest Keysight Sales and Service Office if the appropriate power cord is not included with the supply.

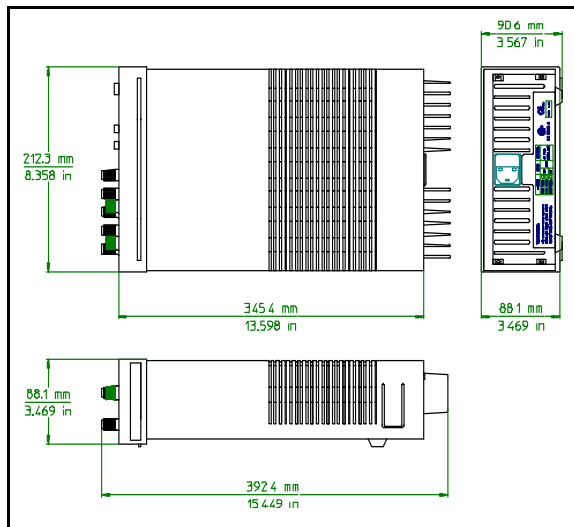

Figure 1. Outline Diagram

## OPERATING INSTRUCTIONS

### INTRODUCTION

This section describes the operating controls and indicators, turn-on checkout procedures, and other operating considerations for the Model E3620A Dual Output Power Supply.

### CAUTION

Before applying power to the supply, check the label on the heat sink to make certain that the supply's line voltage option agrees with the line voltage to be used. If the option does not correspond to your line voltage, refer to paragraph "LINE VOLTAGE OPTION CONVERSION" in the service section before applying power.

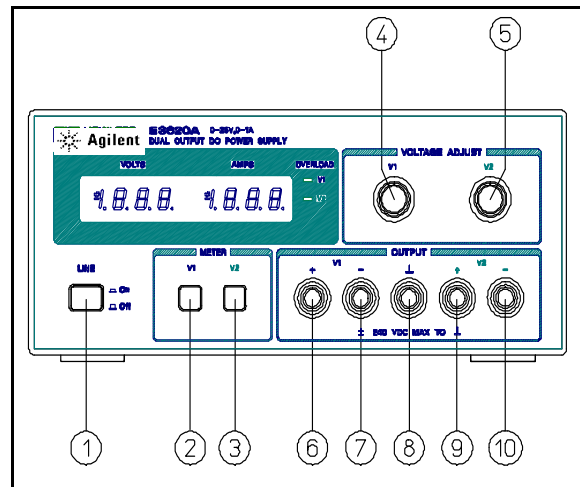

Figure 2. Front-Panel Controls and Indicators

## CONTROLS

### Line Switch

The LINE pushbutton switch (1, Figure 2) is pushed-in to turn the supply ON and released (out position) to turn the supply OFF.

### Voltage and Current Metering

Two meter select pushbutton switches (2 and 3) permit the output voltage and current of either output (V1 or V2) to be monitored on the VOLTS/AMPS meter. The V1 and V2 output select pushbuttons connect the desired output to the metering circuit when the applicable button is pushed in.

### NOTE

Be careful that both METER pushbuttons are not released (out-position) or pushed in simultaneously.

### Voltage Controls

The V1 and V2 voltage controls (4 and 5) set the voltage level of the corresponding output. The voltage controls are 10 turn potentiometers.

## TURN-ON CHECKOUT PROCEDURE

The following steps describe the use of the Model E3620A front panel controls illustrated in **Figure 2** and serve as a brief check that the supply is operational. Follow this checkout procedure or the more detailed performance test of service information section when the instrument is received and before it is connected to any load equipment. Proceed to the more detailed performance test beginning in service information section if any difficulties are encountered.

- a. Connect line cord to power source and push LINE switch (①) in.
- b. Push the V1 meter select pushbutton switch (②) to in-position to monitor supply's V1 output voltage. With no load connected, vary the V1 voltage control (④) over its range and check that the voltmeter responds to the control setting and the ammeter indicates zero.
- c. Turn the V1 voltage control (④) fully clockwise and short the +V1 output terminal (⑥) to -V1 terminal (⑦) with an insulated test lead. The ammeter should indicate a short-circuit output current of minimum 1.0 A + 5% at 25 °C. Remove the short from the output terminals.
- d. Push the V2 meter select pushbutton switch to in-position and repeat steps (b) and (c) for V2 output.

If this brief checkout procedure or later use of the supply reveals a possible malfunction, see the service information section for detailed test, troubleshooting, and adjustment procedures.

## OPERATION

The dual outputs of the E3620A can be used individually, in series, or in parallel. Each output can be floated (up to 240 volts off ground) or, the + or - terminal of either output can be grounded to the chassis ground terminal which is located on the supply's front panel.

### Overload Protection Circuits

The outputs are individually protected against overload or short circuit damage by separate current limiting circuits. The circuits are factory adjusted to limit the output current to minimum 1 A + 5%. The current limits are set by adjusting R63 in the V1 supply and R34 in the V2 supply (see the schematic diagram). No deterioration of supply performance occurs if the output current remains below the current limit setting.

### NOTE

*During the actual operation of the V1 and V2 outputs, if a load change causes the current limit to be exceeded, the OVERLOAD LED is lighted. If overload conditions occur, the V1 and V2 supplies will protect the load by limiting the current to minimum 1 A + 5%. The V1 and V2 supplies are self restoring; that is, when the overload is removed or corrected, the output voltage is automatically restored to the previously set value.*

## Operation Beyond Rated Output

The supply may be able to provide voltages and currents greater than its rated maximum outputs if the line voltage is at or above its nominal value. Operation can be extended up to 5% over the rated output without damage to the supply, but performance cannot be guaranteed to meet specifications above the rated output of 0 to 25 V at 1 A.

## Connecting Load

Connect each load to the power supply output terminals using separate pairs of connecting wires. This will minimize mutual coupling effects between loads and takes full advantage of the low output impedance of the supply. Load wires must be of adequately heavy gauge to maintain satisfactory regulation at the load.

Make each pair of connecting wires as short as possible and twist or shield them to reduce noise pick-up. If a shield is used, connect one end of the shield to the power supply ground terminal and leave the other end unconnected.

If load considerations require locating output power distribution terminals at a distance from the power supply, then the power supply output terminals should be connected to the remote distribution terminals by a pair of twisted or shielded wires and each load should be connected to the remote distribution terminals separately.

## Series Operation

The two outputs (V1 and V2) can be connected in series to obtain a voltage (up to 50 V) higher than that available from a single output. Each output control (V1 and V2) must be adjusted in order to obtain the total output voltage. Diodes connected internally across each output protect the supply's output filter capacitors against reverse voltages. This could occur if the supplies are connected in series and the output is shorted.

## Parallel Operation

The V1 and V2 supplies can be connected in parallel to obtain a total output current greater than that available from one supply. The total output current is the sum of the output currents of the individual supplies. The output voltage controls of one power supply should be set to the desired output voltage, and the other supply set for a slightly larger output voltage. The supply set to the lower output voltage will act as a constant voltage source, while the supply set to the higher output will act as a current-limited source, dropping its output voltage until it equals that of the other supply. The constant voltage source will deliver only that fraction of its rated output current necessary to fulfill the total current demand.

## LOAD CONSIDERATIONS

This section provides information on operating your supply with various types of loads connected to its output.

### PULSE LOADING

The power supply will automatically cross over from constant-voltage to current-limit operation in response to an increase in the output current over the preset limit. Although the preset limit may be set higher than the average output current, high peak currents (as occur in pulse loading) may exceed the preset current limit and cause crossover to occur and degrade performance.

### REVERSE CURRENT LOADING

An active load connected to the supply may actually deliver a reverse current to the supply during a portion of its operating cycle. An external source cannot be allowed to pump current into the supply without risking loss of regulation and possible damage to the output capacitor of the supply. To avoid these effects, it is necessary to preload the supply with a dummy load resistor so that the supply delivers current through the entire operating cycle of the load devices.

## OUTPUT CAPACITANCE

An internal capacitor across the output terminals of the supply helps to supply high-current pulses of short duration during constant-voltage operation. Any capacitance added externally will improve the pulse current capability, but will decrease the load protection provided by the current limiting circuit. A high-current pulse may damage load components before the average output current is large enough to cause the current limiting circuit to operate.

## REVERSE VOLTAGE PROTECTION

A diode is connected across the output terminals with reverse polarity. This diode protects the output electrolytic capacitors and the series regulator transistors from the effects of a reverse voltage applied across the output terminals. Since series regulator transistors cannot withstand reverse voltage either, diodes are also connected across them. When operating supplies in parallel, these diodes protect an unenergized supply that is in parallel with an energized supply.

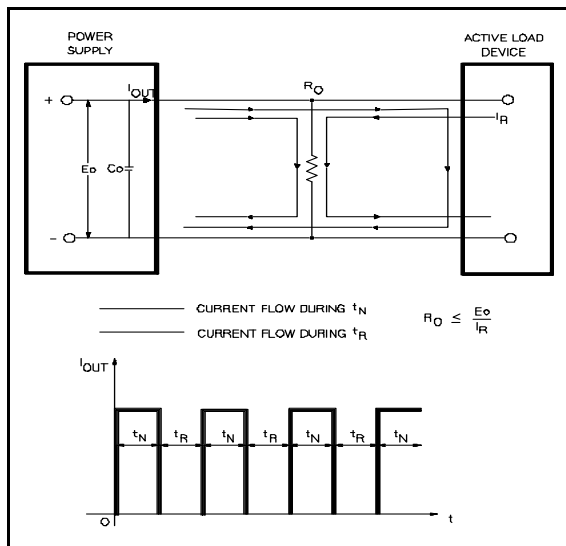

Figure 3. Reverse Current Loading Solution

# SERVICE INFORMATION

## MAINTENANCE

### INTRODUCTION

This section provides performance test, troubleshooting information, and adjustment and calibration procedures. The following operation verification tests comprise a short procedure to verify that the power supply is performing properly, without testing all specified parameters.

If a fault is detected in the power supply while making the performance check or during normal operation, proceed to the troubleshooting procedures. After troubleshooting, perform any necessary adjustments and calibrations. Before returning the power supply to normal operation, repeat the performance check to ensure that the fault has been properly corrected and that no other faults exist.

### Test Equipment Required

Table A-1 lists the equipment required to perform the various procedures described in this section.

### Operation Verification Tests

The following tests assure that the power supply is performing properly. They do not, however, check all the specified parameters tested in the complete performance test described below. Proceed as follows:

- Perform turn-on checkout procedure given in [page 1-11](#).
- Perform the load regulation performance tests given in the following paragraphs.

**Table A-1. Test Equipment Required**

TYPE	REQUIRED CHARACTERISTICS	USE	RECOMMENDED MODEL
Oscilloscope	Sensitivity : 100 $\mu$ V Bandwidth : 20 MHz/100 MHz	Display transient response and ripple and noise waveforms.	Keysight 54503A
RMS Voltmeter	True rms, 20 MHz bandwidth Sensitivity : 1 mV Accuracy : 5%	Measure rms ripple and noise voltage.	
Multimeter	Resolution : 100 nV Accuracy : 0.0035%	Measure DC voltages.	Keysight 34401A
Electronic Load	Voltage Range : 240 VDC Current Range : 10 ADC Open and short switches Transient on/off	Measure load and line regulation.	Keysight 6063A
Resistive Loads ( $R_L$ )	25 $\Omega$ 5% 100 W	Measure ripple and noise.	
Current Sampling Resistor (Shunt)	0.1 $\Omega$ 0.1% 3 W	Measure output current.	
Variable Voltage Auto Transformer	Range : 85-130 and 200-260 Volts	Vary AC input.	

### Line Voltage Option Conversion

To convert the supply from one line voltage option to another, the following three steps are necessary:

- After making certain that the line cord is disconnected from a source of power, remove the top cover from the supply and set the two sections of the line voltage selector switch for the desired line voltage (see [Figure A-1](#)).
- Check the rating of the installed fuse and replace it with the correct value, if necessary. For Option OE3, use a slow-blow 1 amp fuse. For standard and Option OE9, use a slow-blow 2 amp fuse.
- Mark the instrument clearly with a tag or label indicating the correct line voltage to be used.

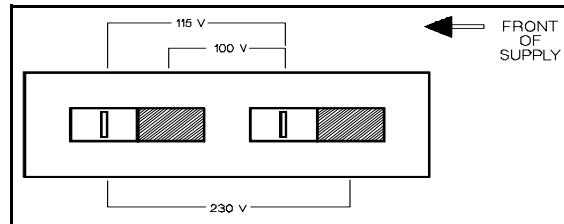

**Figure A-1. Line Voltage Selector (set for 115 VAC)**

## PERFORMANCE TESTS

The following paragraphs provide test procedures for verifying the power supply's compliance with the specifications of Table 1. Proceed to the troubleshooting procedures if you observe any out of specification performance.

### CAUTION

*Before applying power to the supply, make certain that its line voltage selector switch (S1) is set for the line voltage to be used. (See CAUTION notice in operating section for additional information on S1.)*

## General Measurement Techniques

**Connecting Measuring Devices.** To achieve valid results when measuring load regulation, ripple and noise, and transient response time of the supply, measuring devices must be connected as close to the output terminals as possible. A measurement made across the load includes the impedance of the leads to the load. The impedance of the load leads can easily be several orders of magnitude greater than the supply impedance and thus invalidate the measurement. To avoid mutual coupling effects, each measuring device must be connected directly to the output terminals by separate pairs of leads.

When performance measurements are made at the front terminals (Figure A-2) the load should be plugged into the front of the terminals at (B) while the monitoring device is connected to a small lead or bus wire inserted through the hole in the neck of the binding post at (A). Connecting the measuring device at (B) would result in a measurement that includes the resistance of the leads between the output terminals and the point of connection.

**Selecting Load Resistors.** Power supply specifications are checked with a full load resistance connected across the supply output. The resistance and wattage of the load resistor, therefore, must permit operation of the supply at its rated output voltage and current. For example, a supply rated at 25

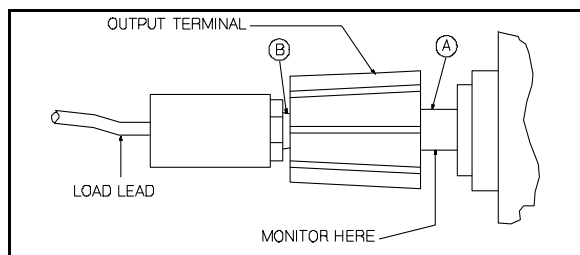

Figure A-2. Front Panel Terminal Connections

volts and 1 amp would require a load resistance of  $25 \Omega$  at the rated output voltage. The wattage rating of this resistor would have to be at least 25 watts.

**Electronic Load.** Some of the performance test procedures require to use an electronic load to test the supply quickly and accurately. An electronic load is considerably easier to use

than a load resistor. It eliminates the need for connecting resistors or rheostats in parallel to handle the power, and it is much more stable than a carbon-pile load. It is easier to switch between load conditions as required for the load regulation and load transient response tests.

**Output Current Measurement.** For accurate output current measurements, a current sampling resistor should be inserted between the load and the output of the supply. To simplify grounding problems, one end of this sampling resistor should be connected to the same output terminal of the supply which will be shorted to ground. An accurate voltmeter is then placed across the sampling resistor and the output current is calculated by dividing the voltage across the sampling resistor by its ohmic value. The total resistance of the series combination should be equal to the full load resistance as determined in the preceding paragraphs. Of course, if the value of the sampling resistor is very low when compared to the full load resistance, the value of the sampling resistor may be ignored. The meter shunt recommended in Table A-1, for example, has a resistance of only  $100 \text{ m}\Omega$  and can be neglected when calculating the load resistance of the supply. Figure A-3 shows a four terminal meter shunt. The load current through a shunt must be fed from the extremes of the wire leading to the resistor while the sampling connections are made as close as possible to the resistance portion itself.

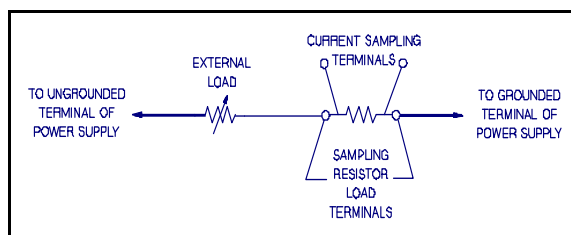

Figure A-3. Current Sampling Resistor Connections

## Rated Output, Meter Accuracy, and Current Limit

To check that all supplies will furnish their maximum rated output voltage and current, that the front panel meters are accurate, and that the current limit circuits function, proceed as follows:

### Rated Output Voltage and Voltmeter Accuracy

- With no loads connected: turn on the supply and push the V1 METER switch in. Connect a DVM between the V1 + and - terminals and set V1 VOLTAGE control until front panel voltmeter indicates 17.00 volts.
- Check the DVM indication. It should be within  $\pm(0.5\% + 2 \text{ counts})$  of the front panel voltmeter indication (16.90 to 17.10 V).
- Set V1 VOLTAGE control clockwise until front panel voltmeter indicates 25.0 volts.
- DVM should indicate 25 volts  $\pm(0.5\% + 2 \text{ counts})$  (24.675 V to 25.325 V).
- Repeat steps (a) through (d) for the V2 supply.

### Rated Output Current and Ammeter Accuracy

- Connect the test setup shown Figure A-4 to the V1 supply's + and - output terminals.



- g. Push the V1 METER switch in to monitor the V1 supply's output current.
- h. Close the load switch and adjust V1 VOLTAGE control until front panel ammeter indicates 1.000 A.
- i. Check that DVM indicates a voltage drop across the current sampling resistor that corresponds to a current of 1 amp  $\pm(0.5\% + 2 \text{ counts})$  (0.993 A to 1.007 A).
- j. Open the load switch and repeat steps (f) through (i) for the V2 supply.

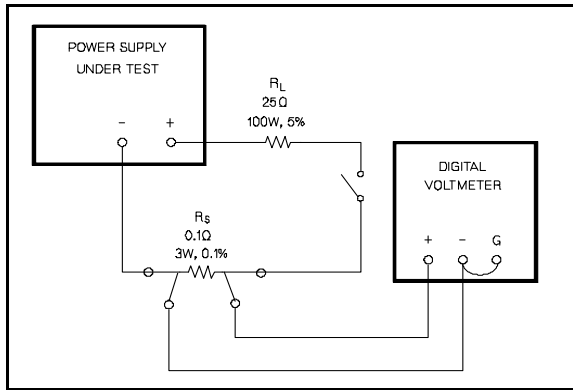

Figure A-4. Output Current, Test Set Up

#### Current Limit

- k. Disconnect all loads from the supply.
- l. Connect the test setup shown in Figure A-4 to the V1 supply's + and - output terminals. Substitute a short for  $R_L$  and leave the load switch open.
- m. Push the V1 METER switch in and adjust the V1 VOLTAGE control fully clockwise.
- n. Close the load switch and determine the current flow through the current sampling resistor  $R_S$  by measuring its voltage drop with the DVM. The current should be minimum 1 A + 5%.
- o. Open the load switch and repeat steps (k) through (n) for the V2 supply.

#### Load Regulation (Load Effect)

**Definition:** The immediate change,  $\bullet E_{OUT}$ , in the static value of DC output voltage resulting from a change in load resistance from open circuit to the value that yields maximum rated output current (or vice versa).

To check the load regulation:

- a. Connect the test equipment across the output of the V1 supply as shown in Figure A-5. Operate the electronic load in constant current mode and set its current to 1.000 A. Input off the electronic load.
- b. Turn on the supply. Push the V1 METER switch in and adjust its voltage to 25.0 volts. Then input on the electronic load.
- c. Record the voltage indicated on the DVM.
- d. Operate the electronic load in open (input off) mode and recheck the DVM indication immediately. The readings' difference during the immediate change should be within 0.01% plus 2 mV of the reading in step (c).
- e. Repeat steps (a) through (d) for the V2 supply.

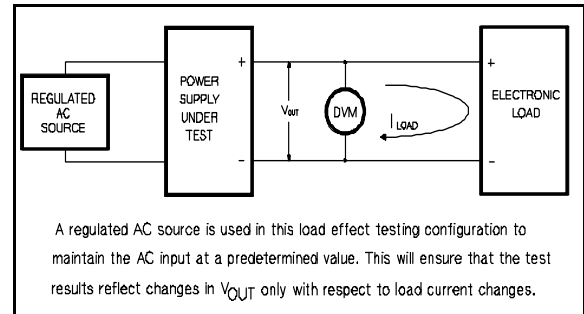

Figure A-5. Basic Test Setup

#### Line Regulation (Source Effect)

**Definition:** The immediate change,  $\bullet E_{OUT}$ , in the static value of DC output voltage resulting from a change in AC input voltage from a minimum to a maximum value ( $\pm 10\%$  of nominal voltage).

To check the line regulation:

- a. Connect a variable autotransformer between the input power source and the power supply line plug.
- b. Connect the test equipment across the output of the V1 supply as shown in Figure A-5. Operate the electronic load in constant current mode and set its current to 1.000 A. Input off the electronic load.
- c. Adjust the autotransformer for a low line input (-10% of nominal voltage).
- d. Turn on the power. Push the V1 METER switch in and adjust the output of the supply to 25.0 volts, then input on the electronic load. Record the DVM indication.
- e. Adjust the autotransformer for high line voltage input (+10% of nominal voltage) and recheck the DVM indication immediately. The readings' difference during the immediate change should be within 0.01% plus 2 mV of the reading in step (d).
- f. Repeat steps (b) through (e) for the V2 supply.

#### Ripple and Noise(Normal Mode Voltage)

**Definition:** Ripple and noise are measured in the rms or peak-to-peak value over a 20 Hz to 20 MHz bandwidth. Fluctuations below the lower frequency limit are treated as drift.

#### RMS Measurement

The rms measurement is not an ideal representation of the noise, since fairly high output noise spikes of short duration could be present in the ripple and not appreciably increase the rms value.

To measure the ripple and noise of the rms value on each output supply output:

- a. Connect the test equipment across the output of the V1 supply as shown in Figure A-6.
- b. Turn on the supply and push the V1 METER switch in.
- c. Adjust the output of the V1 supply to 25.0 volts.
- d. Check that the rms noise voltage at the true rms voltmeter is less than 0.35 mV.
- e. Repeat steps (a) through (d) for the V2 supply.

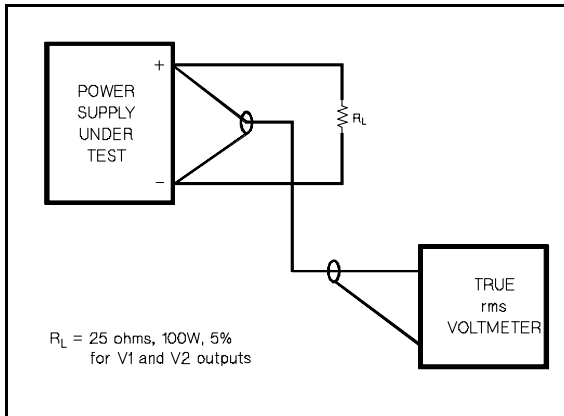

**Figure A-6. Ripple and Noise rms Measurement Test Setup**

### Peak-to-Peak Measurement

The peak-to-peak measurement is particularly important for applications where noise spikes could be detrimental to a sensitive load, such as logic circuitry.

To measure the ripple and noise of the peak-to-peak value on each output supply output:

- Connect the test equipment across the output of the V1 supply as shown in [Figure A-6](#), but replace the true rms voltmeter with the oscilloscope.
- Turn on the supply and push the V1 METER switch in.
- Adjust the output of the V1 supply to 25.0 volts.
- Set the oscilloscope to AC mode and bandwidth to 20 MHz.
- Check that the peak-to-peak noise is less than 1.5 mV.
- Repeat steps (a) through (e) for the V2 supply.

### Common Mode Current (CMI)

**Definition :** Common mode current is that AC current component which exists between any or all supply or output lines and chassis ground.

To measure the common mode current:

- Connect the full load for the V1 output terminal.
- Connect a 100 k $\Omega$  resistor ( $R_S$ ) and a 2200 pF capacitor in parallel between V1 - terminal and chassis ground.
- Connect the DVM across  $R_S$ . Operate the DVM in AC voltage mode.
- Turn on the supply.
- Record the voltage across  $R_S$  and convert it to current by dividing this voltage by  $R_S$ .
- Check that the current is less than 1  $\mu$ A.
- Repeat steps (a) through (f) for the V2 supply.

### Load Transient Response Time

**Definition :** This is the time for the output voltage to return to within a specified band around its voltage following a change from full load to half load or half load to full load.

To measure the load transient response time:

- Connect the test equipment across the output of the V1 supply as shown in [Figure A-5](#), but replace the DVM with the oscilloscope. Operate the electronic load in constant current mode.
- Turn on the supply and push the V1 METER switch in.
- Turn up V1 output voltage to 25.0 volts.
- Set the electronic load to transient operation mode between one half of supply's full rated value and supply's full rated value at a 1 kHz rate with 50% duty cycle.
- Set the oscilloscope for AC coupling, internal sync and lock on either the positive or negative load transient.
- Adjust the oscilloscope to display transients as shown in [Figure A-7](#).
- Check that the pulse width ( $t_2-t_1$ ) of the transients at 15 mV from the base line is no more than 50  $\mu$ sec as shown.
- Repeat steps (a) through (g) for the V2 supply.

### Stability (Drift)

**Definition:** The change in output voltage (DC to 20 Hz) for the first 8 hours following a 30-minute warm-up period with constant input line voltage, constant load resistance and constant ambient temperature.

To measure the stability:

- Connect the test equipment across the output of the V1 supply as shown in [Figure A-5](#).
- Operate the electronic load in constant current mode and set its current to 1.000 A.
- Turn on the supply and push the V1 METER switch in.
- Turn up V1 output voltage to 25.0 volts as read on the digital voltmeter.
- After a 30-minute warm-up, note the voltage on DVM.
- The output voltage reading should deviate less than 0.1% plus 5 mV from the reading obtained in step (e) over a period of 8 hours.
- Repeat steps (a) through (f) for the V2 supply.

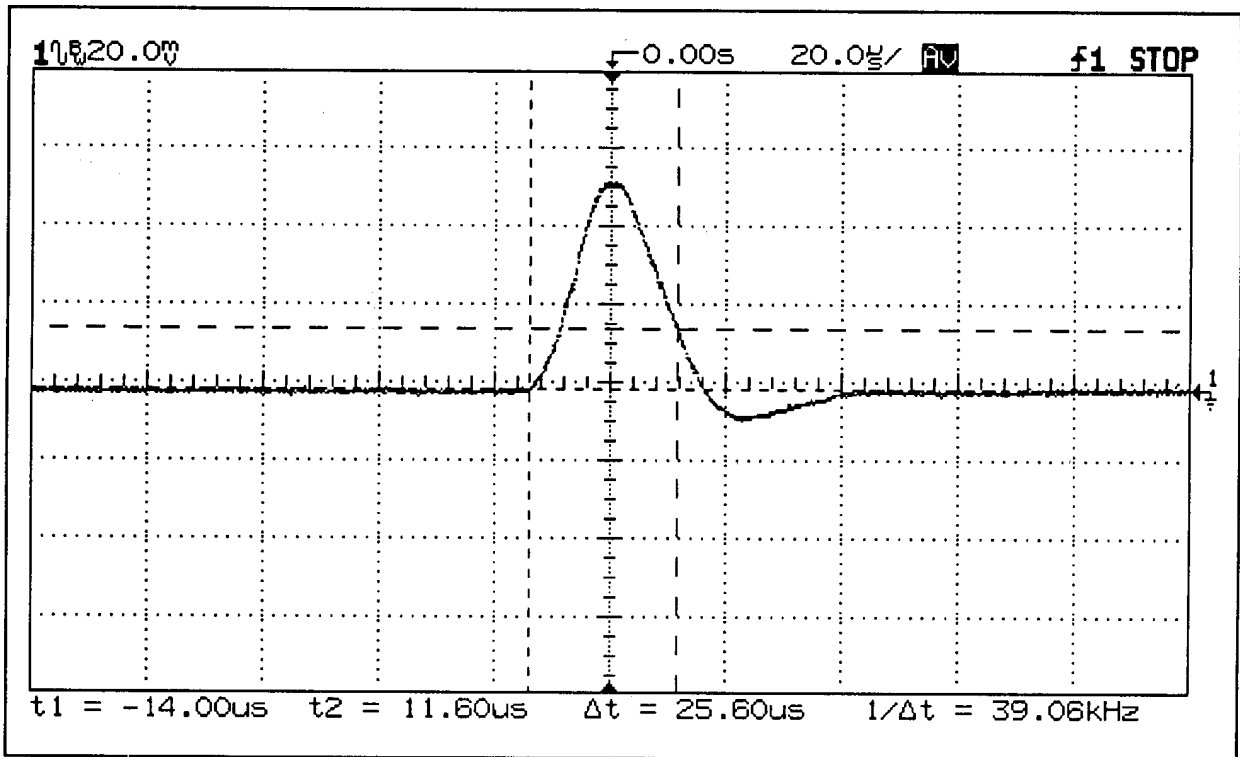

Figure A-7. Load Transient Response Time Waveform

### TROUBLESHOOTING

Before attempting to troubleshoot the power supply, ensure that the fault is with the supply and not with an associated piece of equipment. You can determine this without removing the covers from the power supply by using the appropriate portions of the "Performance Tests" paragraph.

#### CAUTION

*Before applying power to the supply, make certain that its line voltage selector switch (S1) is set for the line voltage to be used.*

### Open Fuse Troubleshooting

Although transients or fatigue can cause a fuse to blow, it is a good idea to inspect the unit for obvious shorts such as damaged wiring, charred components, or extraneous metal parts or wire clippings in contact with circuit board conductors before replacing the fuse. The rating of the correct replacement fuse depends on the line voltage option of the instrument: for Option OE3, use a slow-blow 1 amp fuse and standard and Option OE9, use a slow-blow 2 amp fuse.

### ADJUSTMENT AND CALIBRATION

#### Current Limit Adjustment

To adjust the current limit circuit in the V1 or V2 supply, proceed as follows:

- Turn the current limit adjustment pot (R63 for V1 supply or R34 for V2 supply) to fully counter clockwise.
- Connect the test setup shown in Figure A-4 to the output of the supply to be adjusted. Substitute a short for  $R_L$  and leave load circuit switch open.
- Turn on the supply and set the VOLTAGE control for maximum output (fully clockwise).
- Close load switch and adjust the current limit pot (R63 or R34) until the DVM indicates a voltage drop across the shunt of  $0.1\text{ V} + 5\%$  (0.105 V).

## Meter Calibration

**Voltmeters.** To calibrate voltmeter, proceed as follows:

- a. Connect DVM across V1 + and - output terminal.
- b. Turn on the supply and push V1 METER switch in.
- c. Set the output voltage to 17.00 volts, and adjust R16 on the display board until front panel VOLTS display reads exactly DVM value. Next, set the output voltage to 25.0 volts and adjust R17 on the display board until front panel VOLTS display reads exactly DVM value.
- d. To calibrate the voltmeter for V2 output, push V2 METER switch in and connect DVM across V2 + and - output terminal.
- e. Set the output voltage to 15.00 V and then adjust R81 on the main board until front panel VOLTS display reads exactly DVM value.

**Ammeters.** To calibrate ammeter for V1 and V2 supplies, proceed as follows:

- a. Connect the test setup shown in [Figure A-4](#) to the output of the V1 supply. Substitute a short for  $R_L$  and leave load circuit switch open.
- b. Push V1 METER switch in and turn V1 VOLTAGE control fully clockwise.
- c. Close the load switch and adjust R5 on the display board until front panel AMPS display reads exactly DVM value divided by  $R_S$ .
- d. To calibrate the ammeter for V2 output, repeat step (a) to the V2 supply. Select V2 METER switch and turn V2 VOLTAGE control fully clockwise.
- e. Adjust R80 on the main board until front panel AMPS display reads exactly DVM value divided by  $R_s$ .

# COMPONENT LOCATOR DIAGRAMS

## MAIN BOARD — TOP

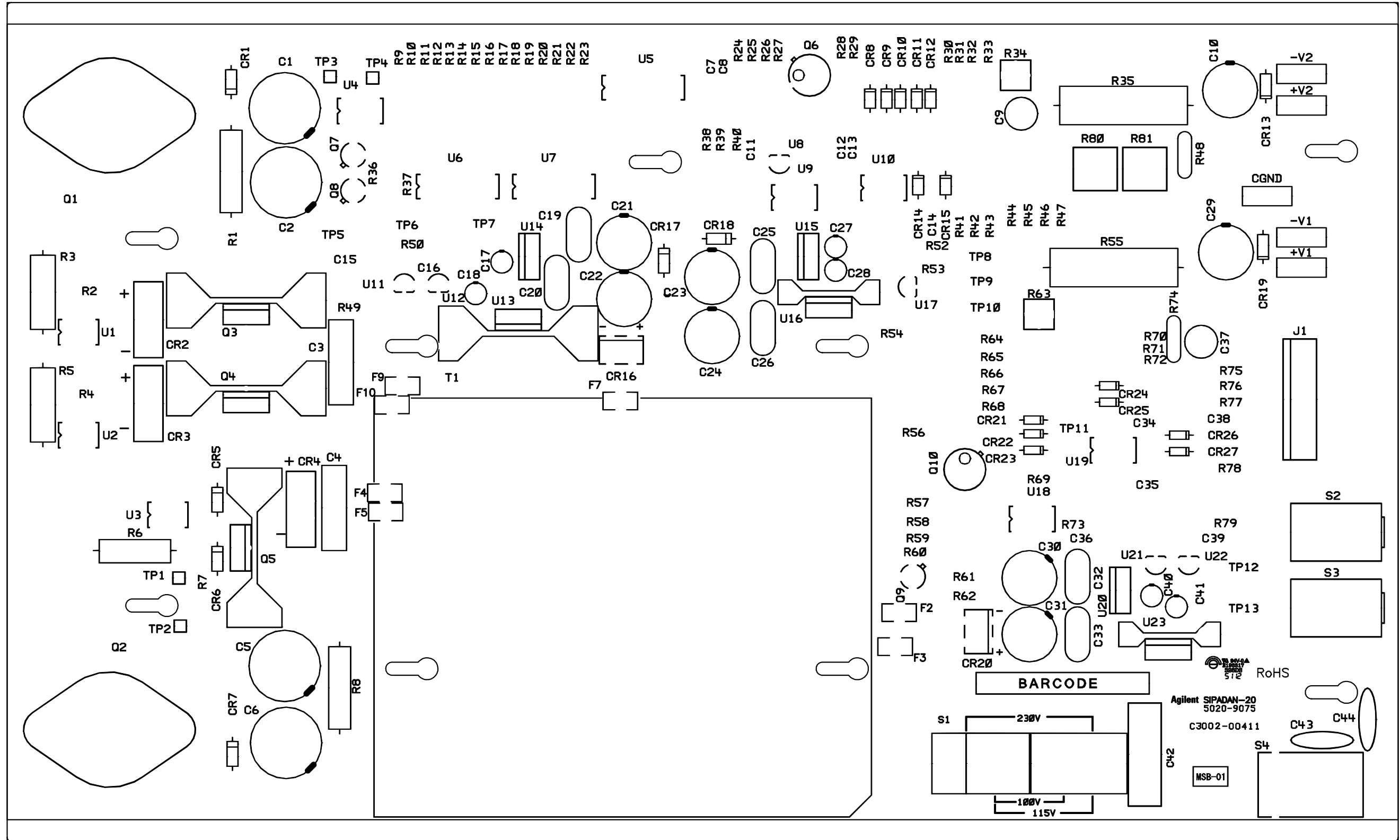

MAIN BOARD — BOTTOM

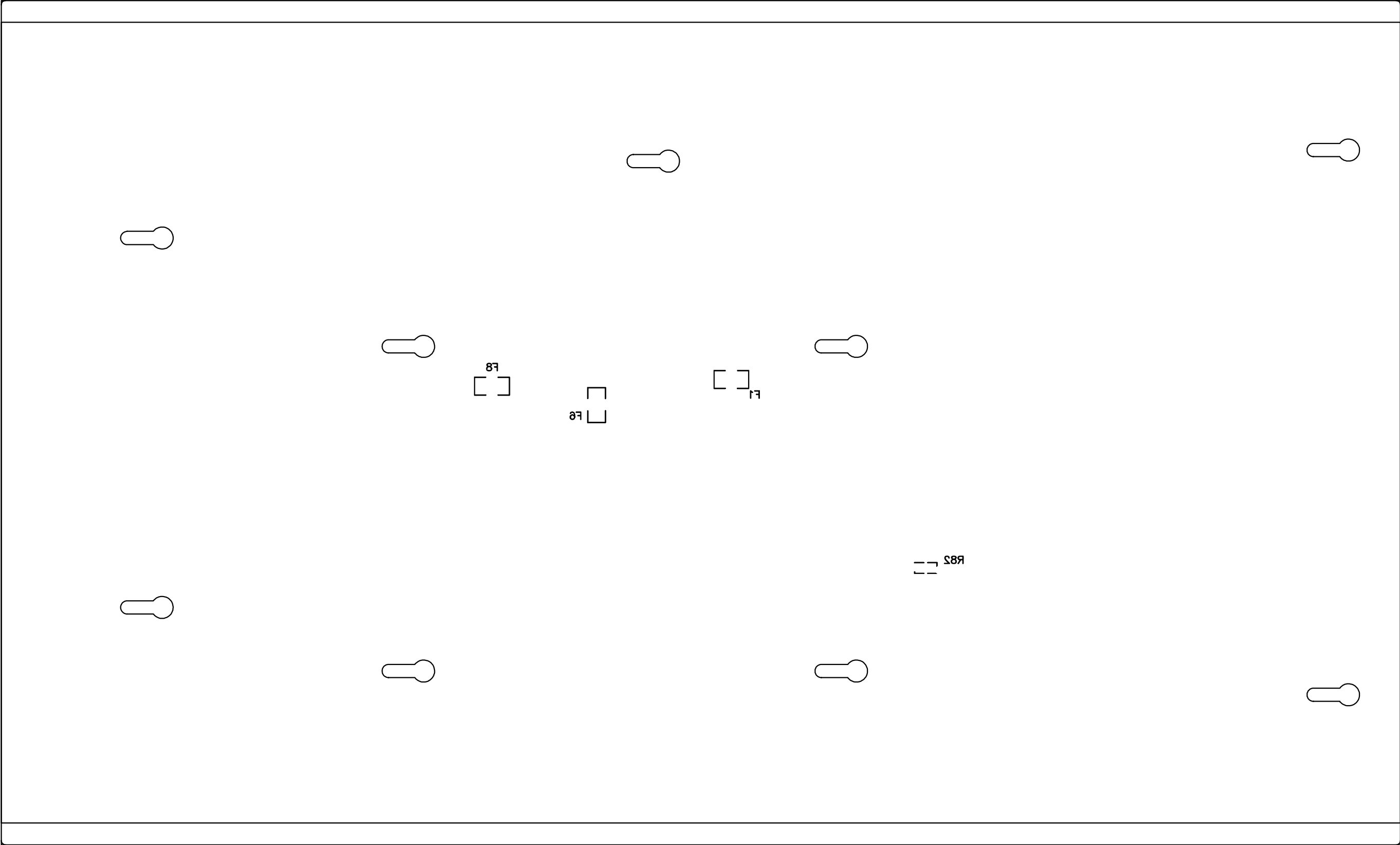

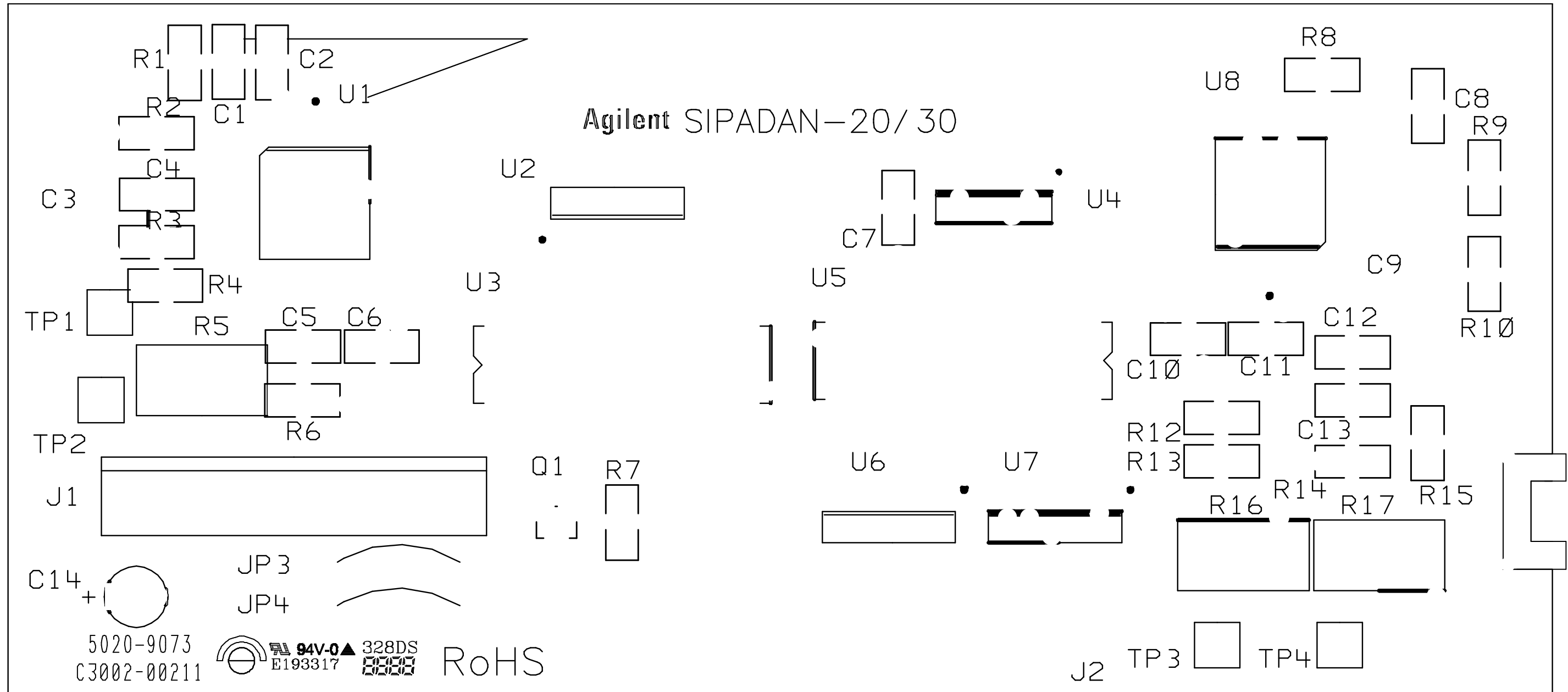

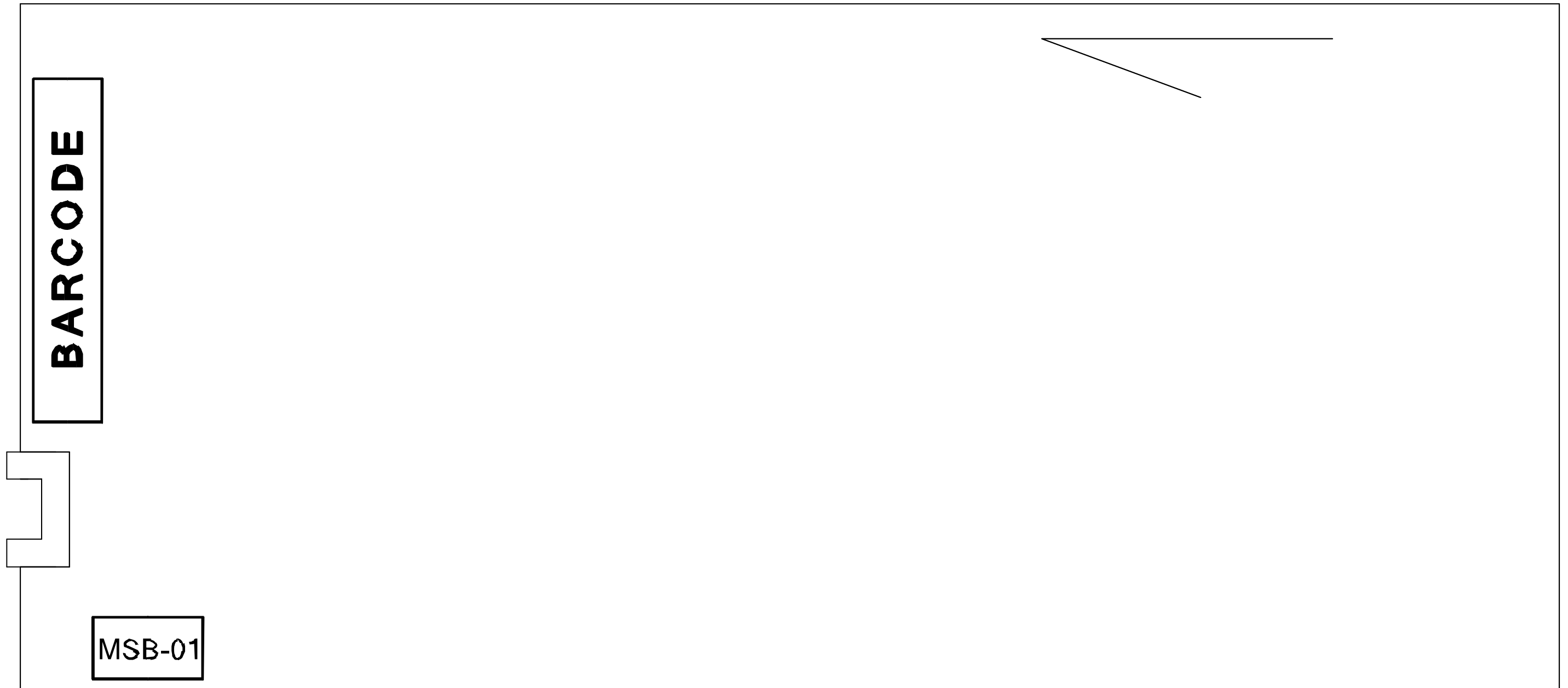



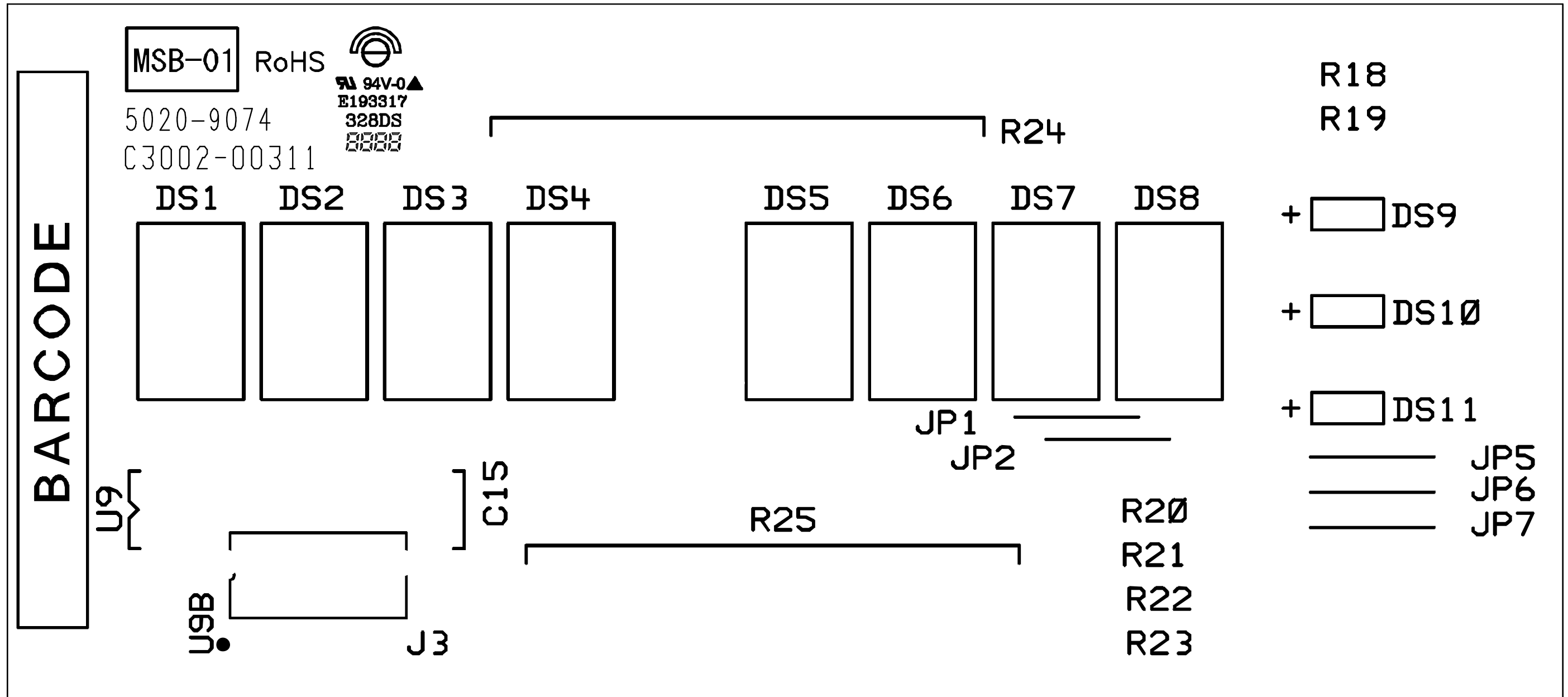

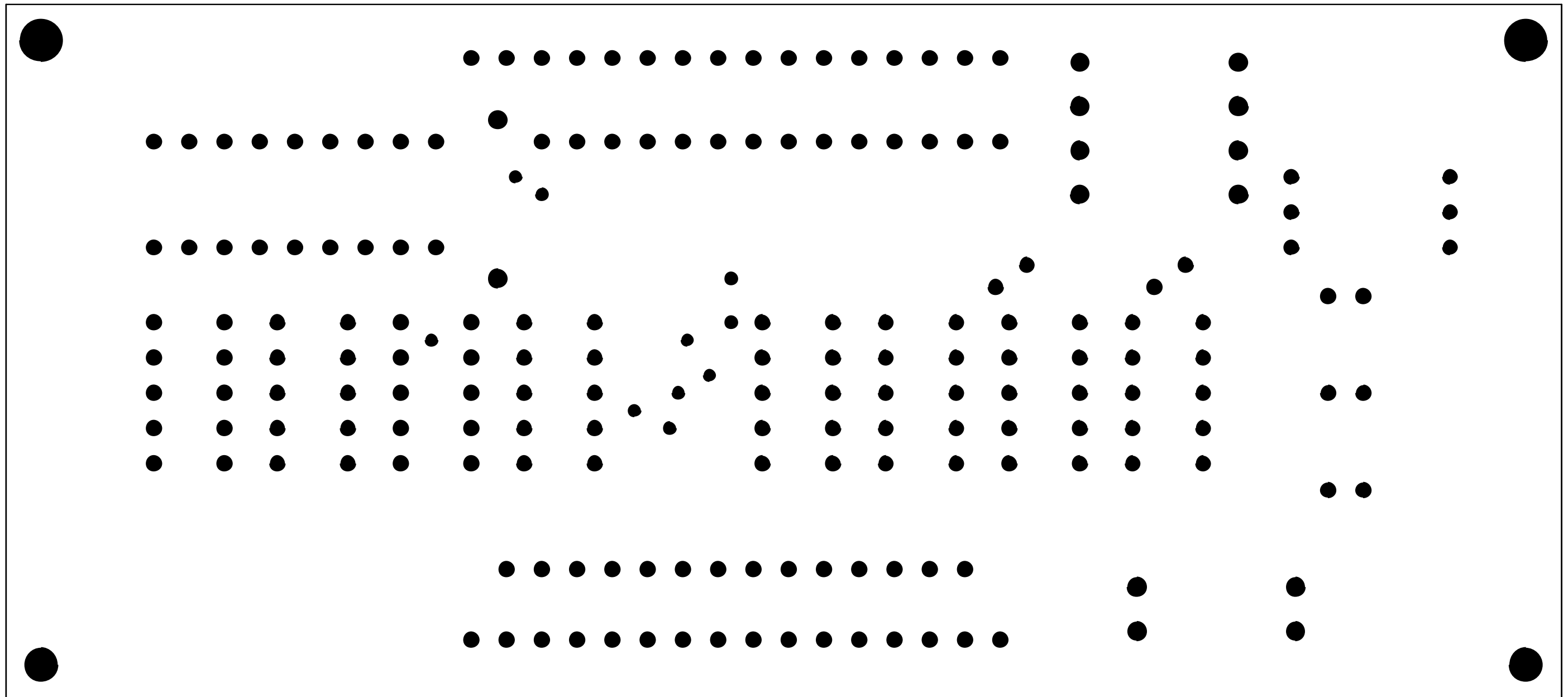

[www.keysight.com](http://www.keysight.com)

### Contact us

To obtain service, warranty, or technical support assistance, contact us at the following phone numbers:

United States:

(tel) 800 829 4444 (fax) 800 829 4433

Canada:

(tel) 877 894 4414 (fax) 800 746 4866

China:

(tel) 800 810 0189 (fax) 800 820 2816

Europe:

(tel) 31 20 547 2111

Japan:

(tel) (81) 426 56 7832 (fax) (81) 426 56 7840

Korea:

(tel) (080) 769 0800 (fax) (080) 769 0900

Latin America:

(tel) (305) 269 7500

Taiwan:

(tel) 0800 047 866 (fax) 0800 286 331

Other Asia Pacific Countries:

(tel) (65) 6375 8100 (fax) (65) 6755 0042

Or visit the Keysight World Wide Web at:

[www.keysight.com/find/assist](http://www.keysight.com/find/assist)

Product specifications and descriptions in this document are subject to change without notice. Always refer to the English version at the Keysight Web site for the latest revision.

This information is subject to change without notice.

© Keysight Technologies 2002 - 2014

Edition 11, November 2014



E3620-90001  
[www.keysight.com](http://www.keysight.com)