

Agilent 16194A High Temperature Component Fixture
Operation and Service Manual



Agilent Part No. 16194-90030
Printed in JAPAN May 2003

Fifth Edition

Notice

The information contained in this document is subject to change without notice.

This document contains proprietary information that is protected by copyright. All rights are reserved. No part of this document may be photocopied, reproduced, or translated to another language without the prior written consent of the Agilent Technologies.

Agilent Technologies Japan, Ltd.
Component Test PGU-Kobe
1-3-2, Murotani, Nishi-ku, Kobe-shi,
Hyogo, 651-2241 Japan

Manual Printing History

The manual printing date and part number indicate its current edition. The printing date changes when a new edition is printed. (Minor corrections and updates that are incorporated at reprint do not cause the date to change.) The manual part number changes when extensive technical changes are incorporated.

March 1994	First Edition (part number: 16194-90000)
May 1998	Second Edition (part number: 16194-90010)
December 1999	Third Edition (part number: 16194-90010)
September 2000	Fourth Edition (part number: 16194-90020)
May 2003	Fifth Edition (part number: 16194-90030)

Safety Summary

The following general safety precautions must be observed during all phases of operation, service, and repair of this instrument. Failure to comply with these precautions or with specific **WARNINGS** given elsewhere in this manual violates safety standards of design, manufacture, and intended use of the instrument.

The Agilent Technologies assumes no liability for the customer's failure to comply with these requirements.

DO NOT Operate In An Explosive Atmosphere

Do not operate the instrument in the presence of flammable gasses or fumes. Operation of any electrical instrument in such an environment constitutes a safety hazard.

Keep Away From Live Circuits

Operating personnel must not remove instrument covers. Component replacement and internal adjustments must be made by qualified maintenance personnel. Do not replace components with the power cable connected. Under certain conditions, dangerous voltages may exist even with the power cable removed. To avoid injuries, always disconnect power and discharge circuits before touching them.

DO NOT Service Or Adjust Alone

Do not attempt internal service or adjustment unless another person, capable of rendering first aid and resuscitation, is present.

DO NOT Substitute Parts Or Modify Instrument

Because of the danger of introducing additional hazards, do not substitute parts or perform unauthorized modifications to the instrument. Return the instrument to a Agilent Technologies Sales and Service Office for service and repair to ensure the safety features are maintained.

Dangerous Procedure Warnings

Warnings, such as the example below, precede potentially dangerous procedures throughout this manual. Instructions contained in the warnings must be followed.

Warning



Dangerous voltages, capable of causing death, are present in this instrument. Use extreme caution when handling, testing, and adjusting this instrument.

The voltage levels found in this test fixture when used with the intended instruments do not warrant more than normal safety precautions for operator safety.

Operating Precaution

Do not exceed the operating input power, voltage, and current level and signal type appropriate for the instrument being used, refer to your instrument's operation manual.

Caution



Electrostatic discharge (ESD) can damage the highly sensitive microcircuits in your instrument. ESD damage is most likely to occur as the test fixtures are being connected or disconnected. Protect them from ESD damage by wearing a grounding strap that provides a high resistance path to ground. Alternatively, ground yourself to discharge any static charge built-up by touching the outer shell of any grounded instrument chassis before touching the test port connectors.

Never touch the test clip contacts.

Use a work station equipped with an anti-static work surface.

Certification

Agilent Technologies certifies that this product met its published specifications at the time of shipment from the factory. Agilent Technologies further certifies that its calibration measurements are traceable to the United States National Institute of Standards and Technology, to the extent allowed by the Institution's calibration facility, or to the calibration facilities of other International Standards Organization members.

Warranty

This Agilent Technologies instrument product is warranted against defects in material and workmanship for a period of one year from the date of shipment, except that in the case of certain components listed in *Instrument Specifications* of this manual, the warranty shall be for the specified period. During the warranty period, Agilent Technologies will, at its option, either repair or replace products which prove to be defective.

For warranty service or repair, this product must be returned to a service facility designated by Agilent Technologies. Buyer shall prepay shipping charges to Agilent Technologies and Agilent Technologies shall pay shipping charges to return the product to Buyer. However, Buyer shall pay all shipping charges, duties, and taxes for products returned to Agilent Technologies from another country.

Agilent Technologies warrants that its software and firmware designated by Agilent Technologies for use with an instrument will execute its programming instruction when properly installed on that instrument. Agilent Technologies does not warrant that the operation of the instrument, or software, or firmware will be uninterrupted or error free.

Limitation Of Warranty

The foregoing warranty shall not apply to defects resulting from improper or inadequate maintenance by Buyer, Buyer-supplied software or interfacing, unauthorized modification or misuse, operation outside of the environmental specifications for the product, or improper site preparation or maintenance.

No other warranty is expressed or implied. Agilent Technologies specifically disclaims the implied warranties of merchantability and fitness for a particular purpose.

Exclusive Remedies

The remedies provided herein are buyer's sole and exclusive remedies. Agilent Technologies shall not be liable for any direct, indirect, special, incidental, or consequential damages, whether based on contract, tort, or any other legal theory.

Assistance

Product maintenance agreements and other customer assistance agreements are available for Agilent Technologies products.

For any assistance, contact your nearest Agilent Technologies Sales and Service Office. Addresses are provided at the back of this manual.

Safety Symbols

General definitions of safety symbols used on equipment or in manuals.



Instruction manual symbol: the product is marked with this symbol when it is necessary for the user to refer to the instruction manual in order to protect against damage to the instrument.



Indicates dangerous voltage (terminals fed from the interior by voltage exceeding 1000 volts must be so marked).

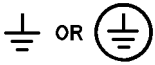

Protective conductor terminal. For protection against electrical shock in case of a fault. Used with wiring terminals to indicate the terminal which must be connected to ground before operating equipment.



Low-noise or noiseless, clean ground (earth) terminal. Used for a signal common, as well as providing protection against electrical shock in case of fault. A terminal marked with this symbol must be connected to ground in the manner described in the installation (Operation) manual, and before operating the equipment.

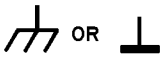

Frame or chassis terminal. A connection to the frame (chassis) of the equipment which normally includes all exposed metal structures.



Alternating current (power line).



Direct current (power line).



Alternating or direct current (power line).

Warning



Warning denotes a hazard. It calls attention to a procedure, practice, condition or the like, which, if not correctly performed or adhered to, could result in injury or death to personnel.

Caution



Caution sign denotes a hazard. It calls attention to a procedure, practice, condition or the like, which, if not correctly performed or adhered to, could result damage to or destruction of part or all of the product.

Note



Note denotes important information. It calls attention to a procedure, practice, condition or the like, which is essential to highlight.

APC-7® is a U.S. registered trademark of the Bunker Ramo Corporation.

Contents

1. General Information	
Introduction	1-1
Manual Summary	1-1
Product Description	1-1
Applicable Instruments	1-1
Options Available	1-2
Accessories Supplied	1-2
Specifications	1-2
Supplemental Performance Characteristics	1-3
2. Preparation for Use	
Introduction	2-1
Initial Inspection	2-1
Exchanging the device holder	2-3
Repackaging the Test Fixture for Shipment	2-4
3. Operation	
Introduction	3-1
Operating Flow	3-1
Connecting the Test Fixture for Use	3-2
Placing Shorting Device, Load Device, or Device Under Test	3-3
Setting the Open Condition	3-4
4. Service	
Introduction	4-1
Assembly Replacement	4-1
Replaceable Parts	4-1
Replacement Procedure	4-5
Disassembling Procedure	4-5
Assembling Procedure	4-5
Troubleshooting	4-6
Short and Open Impedance Check	4-6

Figures

1-1. Applicable Device Size	1-3
2-1. 16194A Product Overview	2-2
2-2. Exchanging the Device Holder	2-3
3-1. Connecting the 16194A to the Measurement Terminal	3-2
3-2. Placing the Device	3-3
3-3. Setting Open Condition	3-4
4-1. Replaceable Parts for Main Assembly	4-2
4-2. Replaceable Parts around the Holder Aim Assembly	4-3
4-3. Replaceable Parts for Test Stage	4-4
4-4. View Around the Electrode	4-5

Tables

1-1. Furnished Accessories	1-2
2-1. 16194A Contents	2-2
4-1. Replaceable Parts for Main Assembly	4-2
4-2. Replaceable Parts around the Holder Aim Assembly	4-3
4-3. Replaceable Parts for Test Stage	4-4
4-4. Required Equipment	4-6
4-5. Short and Open Impedance Value Guideline	4-6

General Information

Introduction

The purpose of this manual is to enable you to use your 16194A High Temperature Component Fixture efficiently and confidently.

Manual Summary

This manual contains the following:

- The specification of the 16194A
- Installing the 16194A
- Operating the 16194A
- Ordering replaceable parts for the 16194A

Product Description

The 16194A is used to measure both axial/radial leaded devices and surface mount devices within the temperature range of -55°C to $+200^{\circ}\text{C}$.

Applicable Instruments

The 16194A has been designed specifically for the measurements within the temperature range of -55°C to $+200^{\circ}\text{C}$ using the 4291B with High Temperature Test Head(Option013/014).

The 16194A is also compatible with the following instruments in normal temperature measurements. The operating temperature depends on the specification of each instrument.

4191A, 4195A with 41951A

4194A with 41941A/B and 16099A Terminal Adapter

4 Terminal Pair type LCR Meters/Impedance Analyzers with 16085B Terminal Adapter

Options Available

The following option is supplied for the 16194A:

- Option 010 Add industry standard size short bar set
Option 701 Short bars set (1x1x2.4, 1.6x2.4x2, 3.2x2.4x2.4, 4.5x2.4x2.4)mm

Accessories Supplied

The following accessories are supplied with the 16194A:

Table 1-1. Furnished Accessories

Description	Part Number	Quantity
Operation and Service Manual	P/N 16194-90030	1
Option 701	P/N 16191-29001	1
	P/N 16191-29002	1
	P/N 16191-29003	1
	P/N 16191-29004	1
	P/N 16191-29004	1
Case for Shorting Device	P/N 1540-0692	1
Option 010 ^{*1}	P/N 16191-29005	1
	P/N 16191-29006	1
	P/N 16191-29007	1
	P/N 16191-29008	1
50 Ω Chip Resistor	P/N 0699-2829	10
Tweezers	P/N 8710-2081	1
Wrench	P/N 8710-1181	1

^{*1} Option 010 sizes are the same as industry standard (EIA/EIAJ) SMD sizes. This short bar set has the following SMD sizes included : 1005(mm)/0402(inch), 1608(mm)/0603(inch), 2012(mm)/0805(inch), 3216(mm)/1206(inch). Order option 010 if the SMD that is to be measured has the same size as the EIA/EIAJ sizes.

Specifications

This section lists the complete 16194A specifications. These specifications are the performance standards and limits against which the 16194A is tested. When shipped from the factory, the 16194A meets the following specifications:

Maximum DC Bias Voltage	$\pm 40V$
Operating Temperature	-55 to $+200^{\circ}C$
Operating Humidity (@wet bulb temperature $<40^{\circ}C$)	15 % to 95 % RH
Non-operating Temperature	-55 to $+200^{\circ}C$
Non-operating Humidity (@wet bulb temperature $<65^{\circ}C$)	Up to 90 % RH
Weight	350 g
Dimension	150(W) \times 40(H) \times 80(D) [mm]

Supplemental Performance Characteristics

This section lists supplemental performance characteristics. Supplemental performance characteristics are not specifications, but are typical characteristics included as additional information for the operator. Supplemental performance characteristics are not guaranteed.

Frequency Range

With OPEN/SHORT and electrical length compensation DC to 500 MHz

With OPEN/SHORT/LOAD compensation DC to 2 GHz

Electrical length 50.0 mm

Additional Error* $20 \times f^2$ [%]

(With OPEN/SHORT and electrical length compensation)

Repeatability*

Surface mount device

Inductive device $0.2 + 2.5 \times f$ [Ω]

Capacitive device $80 + 250 \times f$ [μS]

Leaded device

Inductive device $0.4 + 12.5 \times f$ [Ω]

Capacitive device $80 + 500 \times f$ [μS]

Option 701 shorting device size

P/N 16191-29001 $1 \times 1 \times 2.4$ [mm]

P/N 16191-29002 $1.6 \times 2.4 \times 2$ [mm]

P/N 16191-29003 $2.4 \times 2.4 \times 3.2$ [mm]

P/N 16191-29004 $2.4 \times 2.4 \times 4.5$ [mm]

Option 010 shorting device size

P/N 16191-29005 $0.5 \times 0.5 \times 1$ [mm]

P/N 16191-29006 $0.8 \times 0.8 \times 1.6$ [mm]

P/N 16191-29007 $0.8 \times 1.2 \times 2$ [mm]

P/N 16191-29008 $0.8 \times 1.6 \times 3.2$ [mm]

DC resistance of supplied chip resistor $50 \Omega \pm 0.1$ %

* f: frequency (GHz)

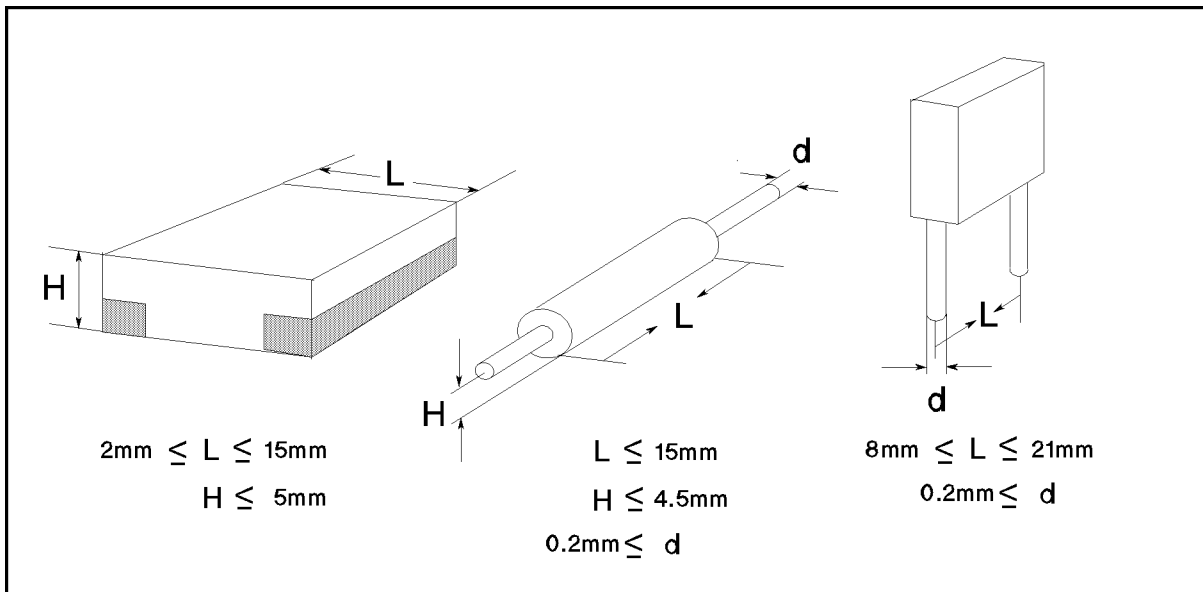

AC501001

Figure 1-1. Applicable Device Size

Supplied Shorting Device Inductance

P/N 16191-29001 (l = 1 mm)	0.2 nH*1
P/N 16191-29002 (l = 2 mm)	0.2 nH*1
P/N 16191-29002 (l = 1.6 mm)	0.2 nH*1
P/N 16191-29002 (l = 2.4 mm)	0.7 nH*2
P/N 16191-29003 (l = 3.2 mm)	0.6 nH*2
P/N 16191-29004 (l = 4.5 mm)	0.6 nH*2

Preparation for Use

Introduction

This chapter explains how to install the 16194A. The topics include the following:

- Initial inspection.
- Exchanging the device holder
- Repackaging the test fixture for shipment.

Initial Inspection

The 16194A has been carefully inspected before being shipped from the factory. It should be in perfect physical condition, no scratches, dents or the like. It should also be in perfect electrical condition. Verify this by carefully performing an incoming inspection to check the 16194A set for signs of physical damage and missing contents. If any discrepancy is found, notify the carrier and Agilent Technologies. Your Agilent Technologies sales office will arrange for repair and replacement without waiting for the claim to be settled.

- Inspect the shipping container for damage. Keep the shipping materials until the inspection is completed.
- Verify that the shipping container contains everything shown in Figure 2-1 and listed in Table 2-1.
- Inspect the exterior of the 16194A for any signs of damage.

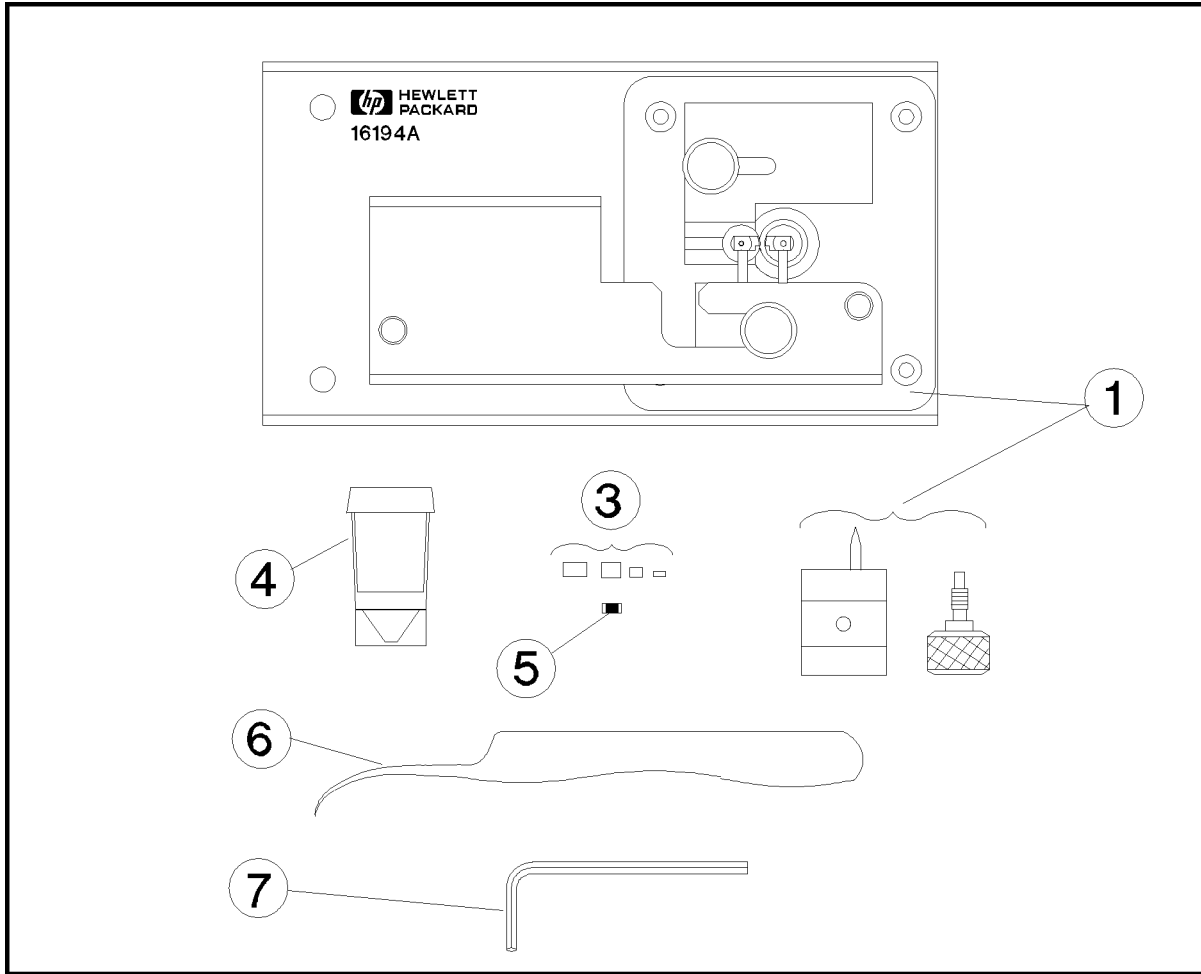

AC5 02/001

Figure 2-1. 16194A Product Overview

Table 2-1. 16194A Contents

Description	Agilent Part Number	Quantity	
① Test fixture	16194A	1	
② Operation and Service Manual ¹	P/N 16194-90030	1	
③ Shorting device	(1×1×2.4[mm]) ²	P/N 16191-29001	1
	(1.6×2.4×2[mm]) ²	P/N 16191-29002	1
	(2.4×2.4×3.2[mm]) ²	P/N 16191-29003	1
	(2.4×2.4×4.5[mm]) ²	P/N 16191-29004	1
④ Case for Shorting Device	P/N 1540-0692	1	
⑤ 50 Ω Chip Resistor	P/N 0699-2829	10	
⑥ Tweezers	P/N 8710-2081	1	
⑦ Wrench	P/N 8710-1181	1	

1 Operation and Service Manual is not shown in Figure 2-1.

2 Contained if you ordered the 16194A option 701.

2.2 Preparation for Use

Exchanging the device holder

The 16194A can hold both leaded devices and surface mount devices by exchanging the device holder. The exchanging procedure is as follows.

1. Remove the ground plate.
2. When measuring a surface mount device, attach the knob on the device holder as shown in Figure 2-2.
3. Select the device holder suitable for the device type. Loosen its knob and insert it into the arm.
4. Set the ground plate.

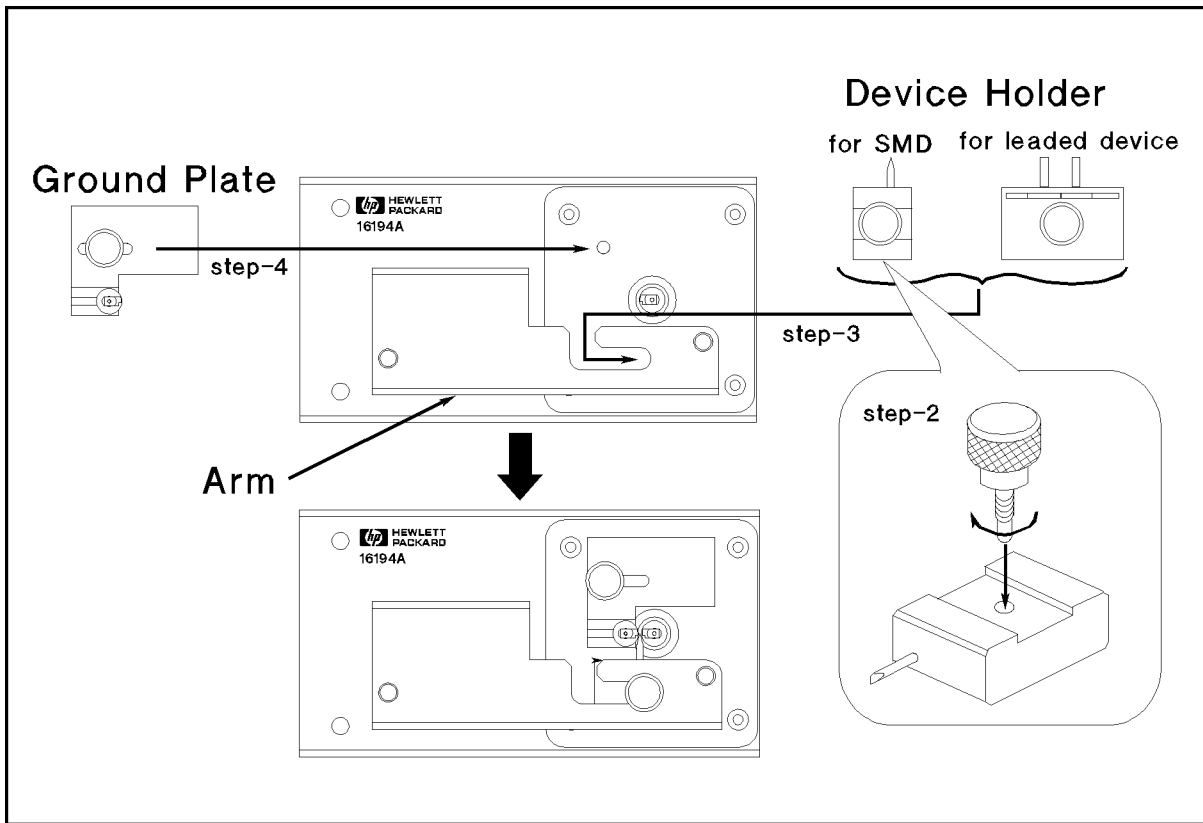

AC502002

Figure 2-2. Exchanging the Device Holder

Repackaging the Test Fixture for Shipment

If shipment to an Agilent Technologies service center is required, each test fixture should be repackaged using the original factory packaging materials.

If this material is not available, comparable packaging materials may be used. Wrap the 16194A in heavy paper and pack in anti-static plastic packing material. Use sufficient shock absorbing material on all sides of the 16194A to provide a thick, firm cushion and to prevent movement. Seal the shipping container securely and mark it *FRAGILE*.

Operation

Introduction

This chapter describes how to perform error compensation and how to measure the device with the 16194A. The topics include the following.

- Operating flow
- Connecting the test fixture for use
- Placing shorting device, load device, or device under test
- Setting the open condition

Operating Flow

The following shows typical operating procedure. Before performing a measurement, it is necessary to compensate for the residual error of the fixture. The error compensation functions are different for each instrument. For procedure on how to perform each error compensation, see the Operation Manual supplied with your analyzer.

1. Perform calibration at the measurement terminal of your analyzer, and connect the 16194A.
2. Perform electrical length compensation(Fixture Select/Port Extension).
3. Perform SHORT compensation.

For both surface mount device and leaded device measurements, use the shorting device.

4. Perform LOAD compensation, if necessary.

For both surface mount device and leaded device measurements, use the 50 Ω chip resistor as a LOAD device. The reference value for LOAD compensation is R=50 Ω / L=0 H.

5. Perform OPEN compensation.

6. Measure the device under test.

Note



In case of using the 4291B with option 013/014 High Temperature Test Head, the recommended error compensation is as follows.

When using option 013	OPEN/SHORT/LOAD
When using option 014 below 500MHz	OPEN/SHORT, Fixture Select
When using option 014 over 500MHz	OPEN/SHORT/LOAD

Warning

The 16194A has the capability for $-55\text{ }^{\circ}\text{C}$ to $+200\text{ }^{\circ}\text{C}$ temperature measurement in environmental testing. Use gloves to prevent burns when handling heated parts.

Connecting the Test Fixture for Use

1. Calibrate your analyzer at the APC-7[®] connector plane before connecting the test fixture.
2. Place the fixture on the APC-7[®] connector.
3. Tighten (turn counterclockwise) the coupling nut of the APC-7[®] connector.

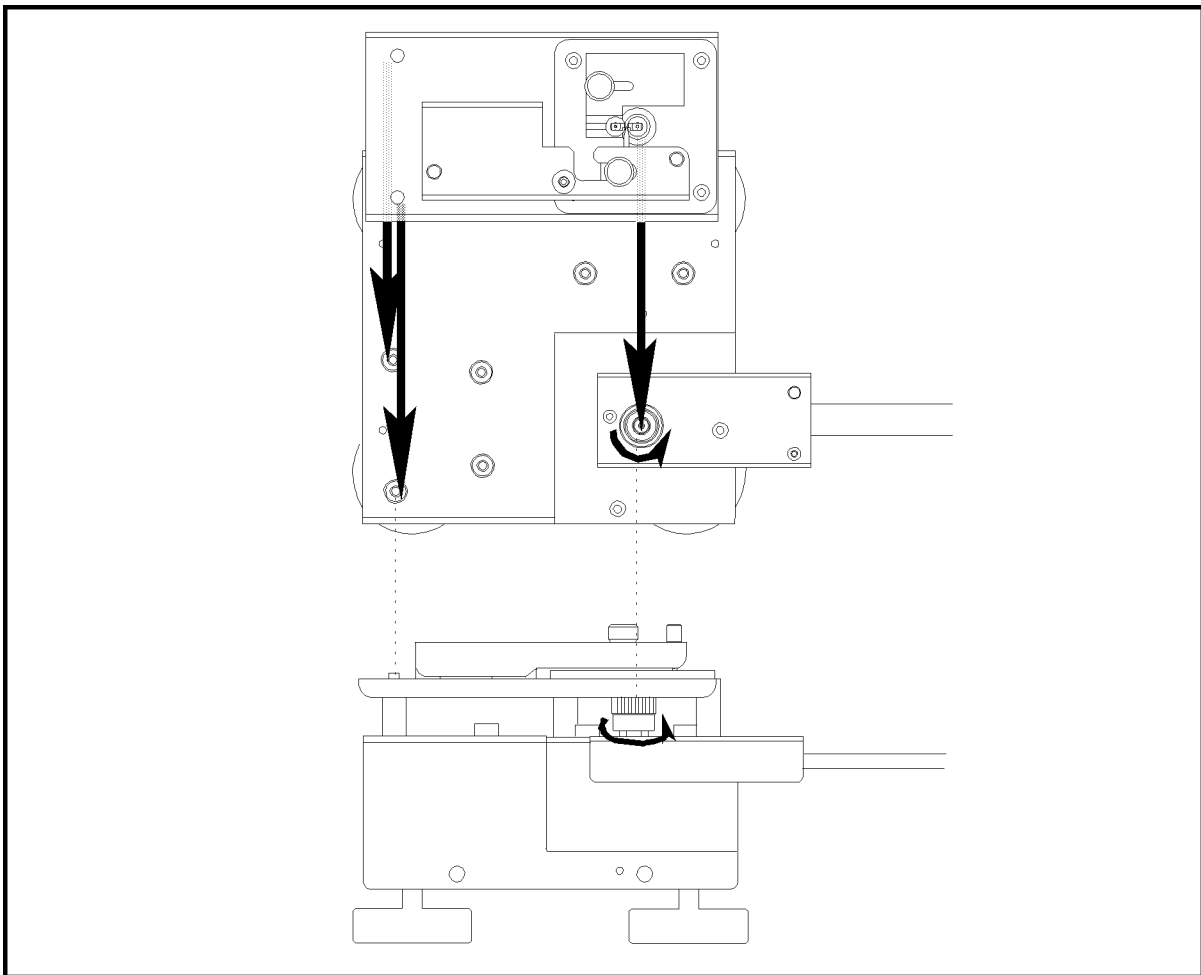

AC503 001

Figure 3-1. Connecting the 16194A to the Measurement Terminal

Placing Shorting Device, Load Device, or Device Under Test

1. Adjust the position of the ground plate and tighten its knob.
2. Adjust the position of the device holder so that it presses against the device. When measuring a leaded device, adjust the distance between the two pins to the device size. Then tighten the knob of the device holder.
3. Move the arm outward.
4. Place the device on the electrodes and press it with the device holder (Figure 3-2 (b) - (d)). When placing a leaded device, put its leads on the notch of the 16194A's electrodes.

You can adjust the pressure of the arm by turning the pressure adjustment using the wrench.

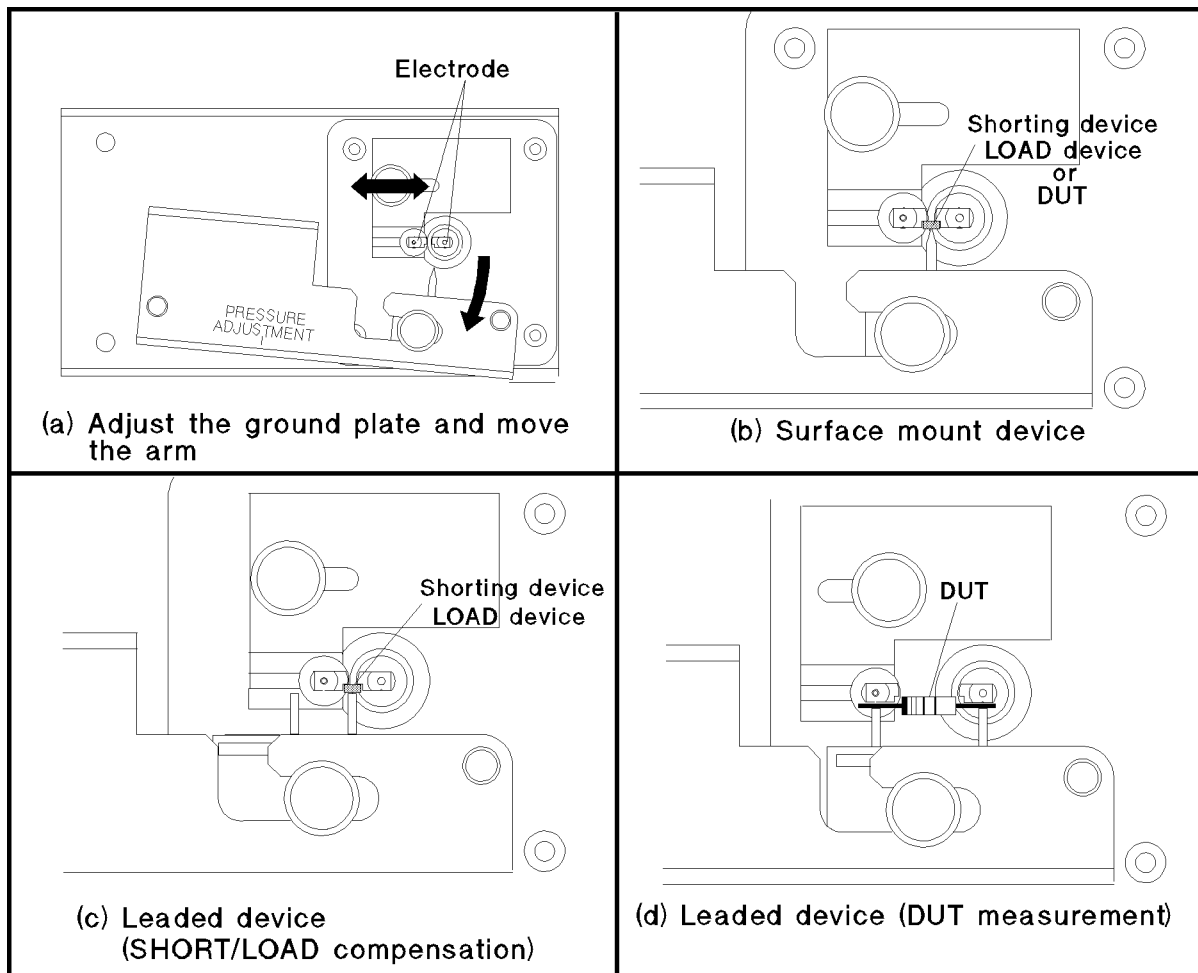

AC503002

Figure 3-2. Placing the Device

Setting the Open Condition

1. If there is any device on the electrodes, remove it.
2. When measuring a surface mount device, move the arm outward and latch it. Then make the distance between the electrodes same as the device size by adjusting the ground plate(Figure 3-3 (a)).
3. When measuring a leaded device, make the distance between the electrodes and the distance between the device holder's pins same as the device size. Then press the electrodes with the device holder's pins, not latching the arm(Figure 3-3 (b)).

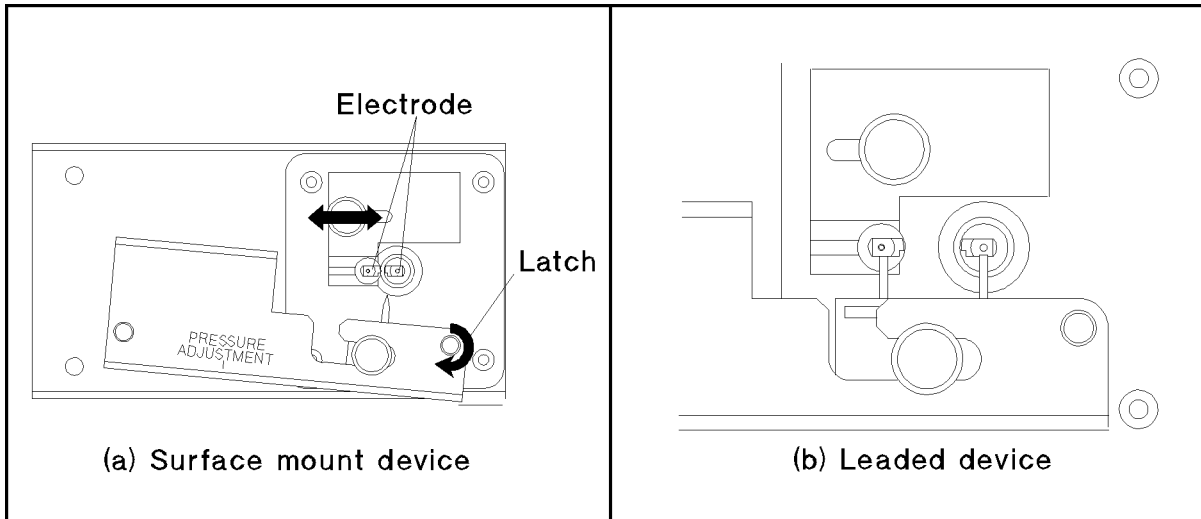

Figure 3-3. Setting Open Condition

Service

Introduction

This chapter covers the following subjects:

- Assembly Replacement
 - Replaceable Parts
 - Replacement Procedure
- Troubleshooting

Warning



This service information is for use by qualified personnel only. Do NOT perform any service function (other than that contained in the operating section) unless you are qualified to do so.

Caution



When you repair the 16194A, put on lint-free gloves to prevent contaminating inner parts of the 16194A. Agilent Technologies supplies lint-free gloves (Agilent part number 9300-0163).

Assembly Replacement

Replaceable Parts

Table 4-1 through Table 4-3 show and list the replaceable parts for the 16194A. The parts listed can be ordered from your nearest Agilent Technologies Office. Ordering information must include the Agilent part number and the quantity required.

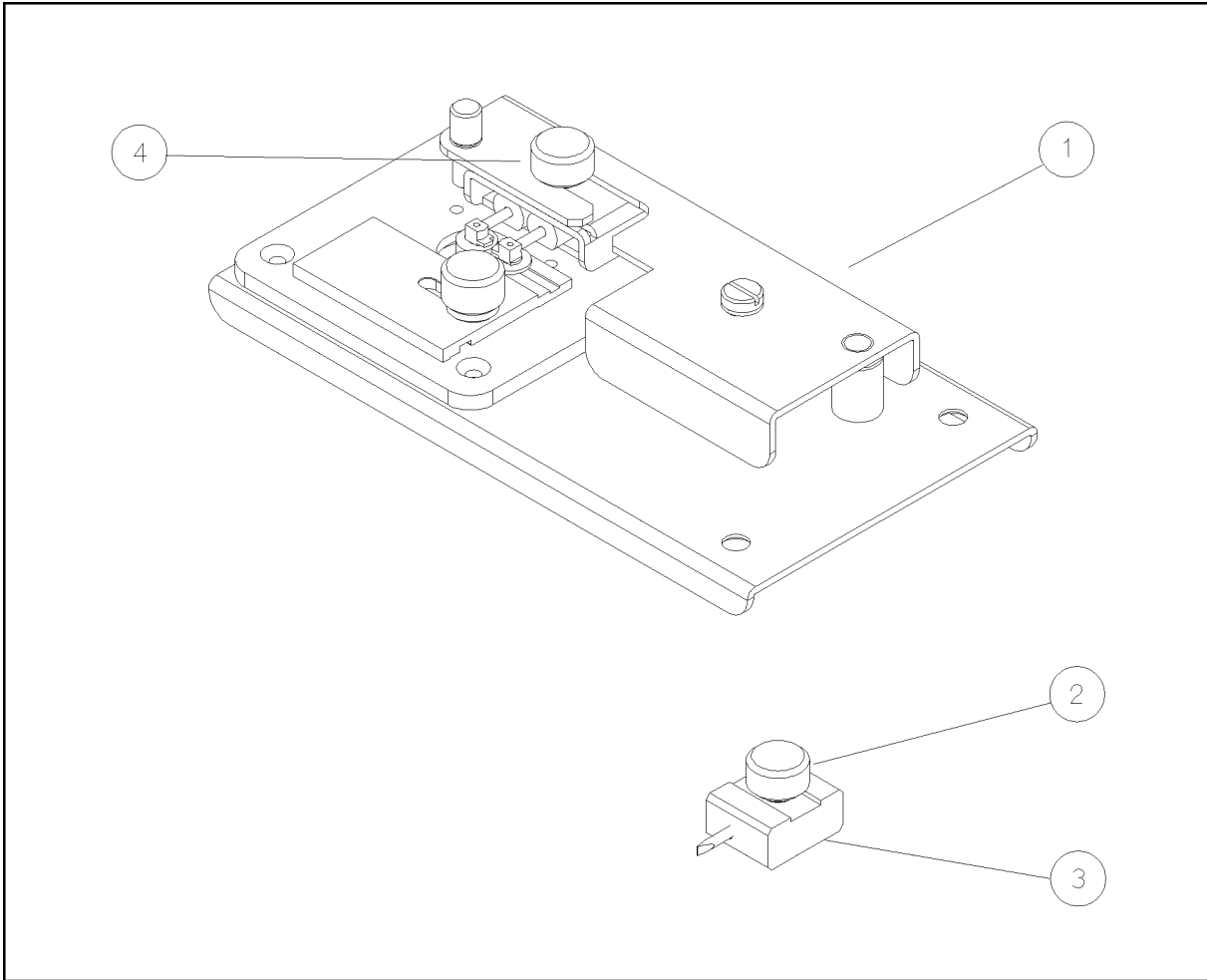

ac504001

Figure 4-1. Replaceable Parts for Main Assembly

Table 4-1. Replaceable Parts for Main Assembly

Reference Designator	Agilent Part Number	Qty.	Description
1	(not assigned)	1	Main Assembly
2	16194-24007	1	Knob
3	16194-60002	1	Device Holder for SMD
4	16194-60001	1	Device Holder for Leaded Device ¹

¹ The parts in the Holder for Leaded Device cannot be replaced separately.

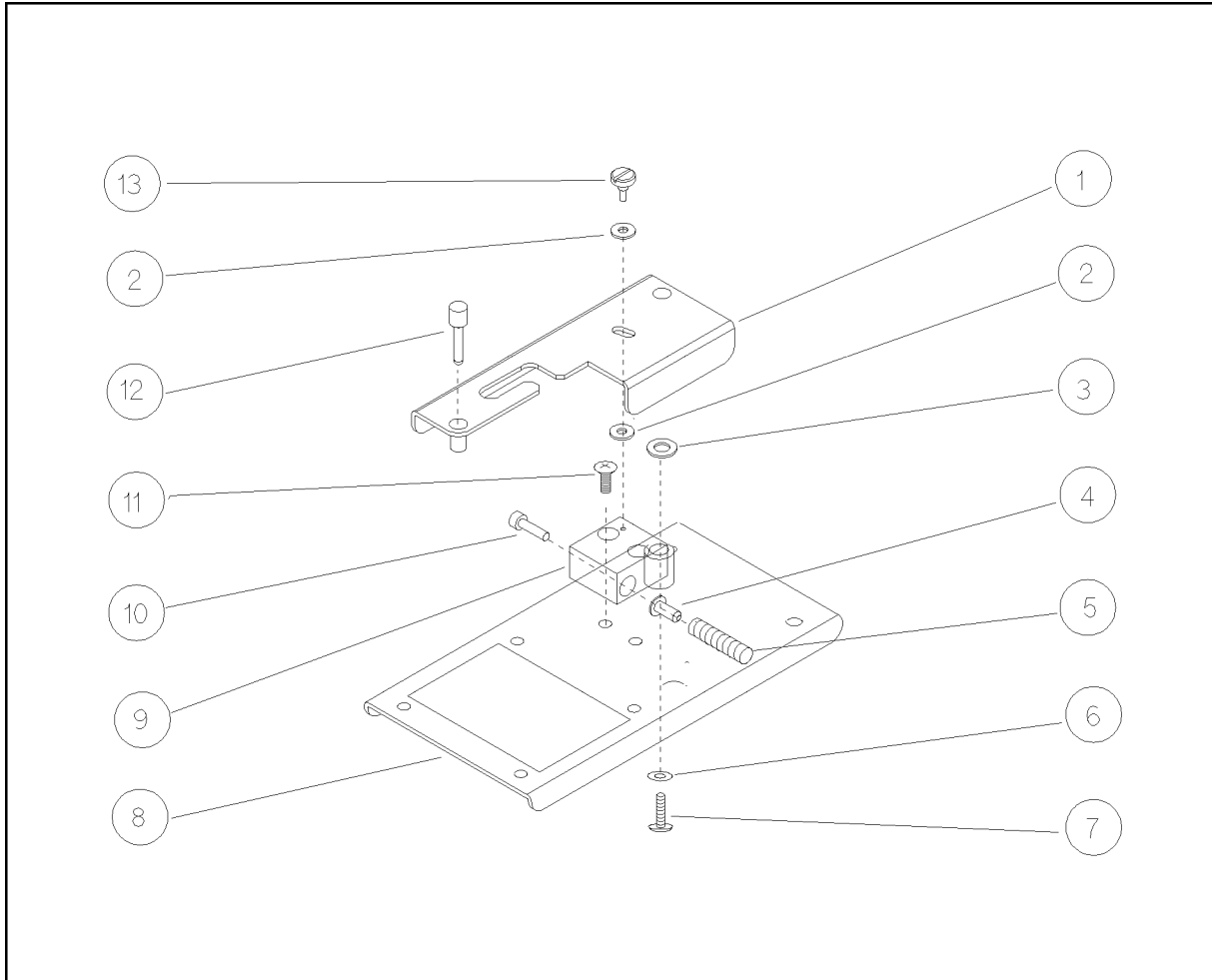

ac504002

Figure 4-2. Replaceable Parts around the Holder Aim Assembly

Table 4-2. Replaceable Parts around the Holder Aim Assembly

Reference Designator	Agilent Part Number	Qty.	Description
1	16194-01201	1	Arm
2	3050-1139	2	Washer, Teflon
3	16194-25003	1	Spacer
4	16191-24010	1	Pin
5	1460-2380	1	Spring
6	3050-0891	1	Washer
7	0515-1550	1	Screw, Pan Head, M3-L8
8	16194-00201	1	Fixture Chassis
9	16194-24008	1	Housing
10	0515-1052	1	Screw, Hex
11	0515-0914	2	Screw, Flat Head, M3-L6
12	16194-24009	1	Latch
13	16194-25004	1	Screw

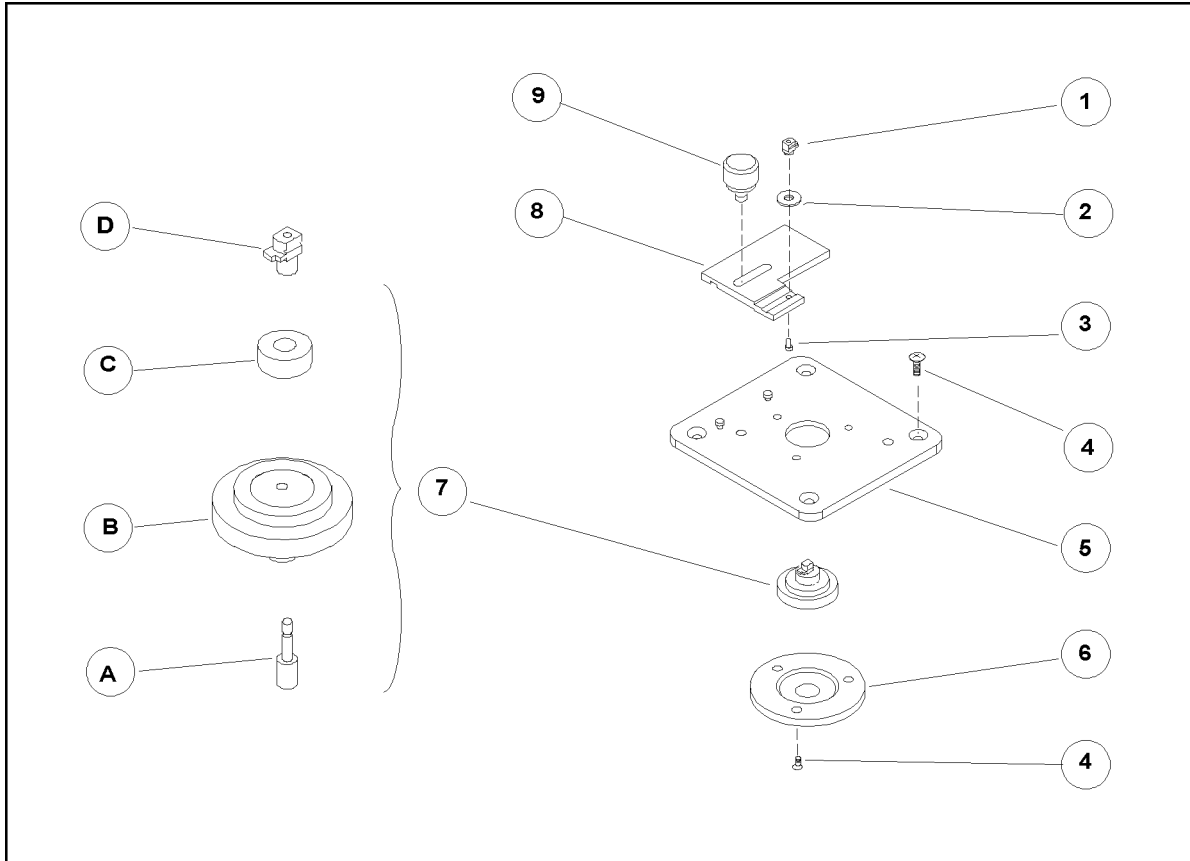

AC504003

Figure 4-3. Replaceable Parts for Test Stage

Table 4-3. Replaceable Parts for Test Stage

Reference Designator	Agilent Part Number	Qty.	Description
1	16194-24002	1	Electrode
2	3050-1139	1	Washer, Teflon
3	0515-2421	1	Screw, Pan Head, M1.4
4	0515-0914	7	Screw, Flat Head, M3
5	16194-20001	1	Test Stage
6	16453-24011	1	Flange
7	(not assigned)	1	Center Conductor Assembly
8	16194-20002	1	Ground Plate
9	16194-24005	1	Knob
A	1250-0816	1	Contact of the APC-7 [®] Center Pin
B	16453-60001	1	Bead Assembly
C	16194-25001	1	Insulator
D	16194-24001	1	Contact of the Electrode

Replacement Procedure

This section covers the disassembling and assembling procedure of the center conductor assembly. See Table 4-3 for the reference designators.

Disassembling Procedure

1. Remove the center conductor assembly ① from the test stage ⑤.
2. Clamp the contact of the APC-7® ④ using pliers which have rubber-covered noses.
3. Loosen the contact ③.

Assembling Procedure

1. Put thread sealant¹ to the screw part of the contact of the APC-7® ④.
2. Assemble the parts ④, ③, ②, and ①.
3. Set the angle of the contact assembly ① as shown in Figure 4-4.

1. Contact to a Agilent Technologies office for the part number of the thread sealant.

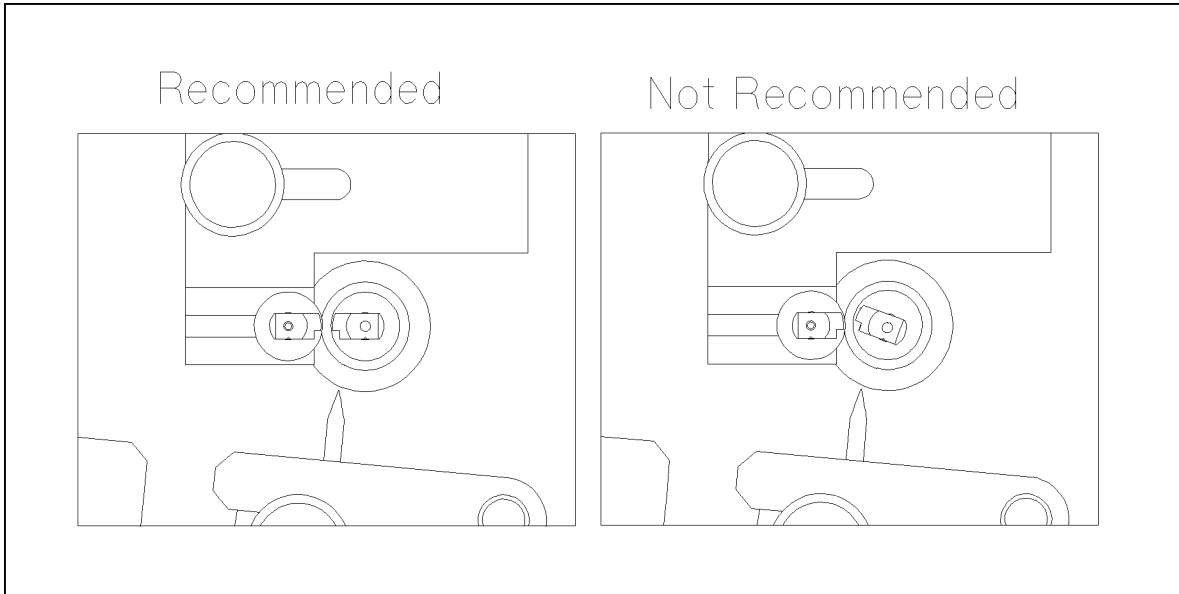

AC504006

Figure 4-4. View Around the Electrode

Troubleshooting

This section includes the procedure used to troubleshoot the 16194A.

Table 4-4. Required Equipment

Equipment	Recommended Model	Substitute Model
Impedance Analyzer	4291B	4396B with 43961A

Short and Open Impedance Check

1. Put the 2.4×2.4×3.2 mm Shorting Device (Agilent PN: 16194-29003) between the electrodes.
2. Place the fixture on the calibrated APC-7[®] terminal of the Impedance Analyzer.
3. Set the Impedance Analyzer as follows:

Measurement Parameter	Ls (series inductance)
Start Frequency	10 MHz
Stop Frequency	100 MHz
OSC Level	0.12 V
Number of Point	2
Point Averaging Factor	16
Point Averaging	ON

4. Perform a single sweep measurement.
5. Read Ls value at 10 MHz and 100 MHz.
6. Keeping the electrode distance, remove the shorting device from the 16194A
7. Set the Impedance Analyzer as follows;

Measurement Parameter	Cp (parallel capacitance)
-----------------------	---------------------------

8. Read Cp value at 10 MHz and 100 MHz.

The guideline for the short and open impedance value is as follows:

Table 4-5. Short and Open Impedance Value Guideline

Parameter	Frequency	Guideline (absolute value)
Short : Ls	10 MHz and 100 MHz	7 nH ± 4 nH
Open : Cp	10 MHz and 100 MHz	2.4 pF ± 0.5 pF

REGIONAL SALES AND SUPPORT OFFICES

For more information about Agilent Technologies test and measurement products, applications, services, and for a current sales office listing, visit our web site: <http://www.agilent.com/find/tmdir>. You can also contact one of the following centers and ask for a test and measurement sales representative. 11/29/99

United States:

Agilent Technologies
Test and Measurement Call Center
P.O.Box 4026
Englewood, CO 80155-4026
(tel) 1 800 452 4844

(fax) (61 3) 9272 0749
(tel) 0 800 738 378 (New Zealand)
(fax) (64 4) 802 6881

Canada:

Agilent Technologies Canada Inc.
5150 Spectrum Way
Mississauga, Ontario
L4W 5G1
(tel) 1 877 894 4414

Asia Pacific:

Agilent Technologies
24/F, Cityplaza One, 1111 King's Road,
Taikoo Shing, Hong Kong
(tel) (852)-3197-7777
(fax) (852)-2506-9284

Europe:

Agilent Technologies
Test & Measurement
European Marketing Organization
P.O.Box 999
1180 AZ Amstelveen
The Netherlands
(tel) (31 20) 547 9999

Japan:

Agilent Technologies Japan Ltd.
Call Center
9-1, Takakura-Cho, Hachioji-Shi,
Tokyo 192-8510, Japan
(tel) (81) 426 56 7832
(fax) (81) 426 56 7840

Latin America:

Agilent Technologies
Latin American Region Headquarters
5200 Blue Lagoon Drive, Suite #950
Miami, Florida 33126
U.S.A.
(tel) (305) 267 4245
(fax) (305) 267 4286

Australia/New Zealand:

Agilent Technologies Australia Pty Ltd
347 Burwood Highway
Forest Hill, Victoria 3131
(tel) 1-800 629 485 (Australia)

