

DIGITAL VOLTMETER

3456A

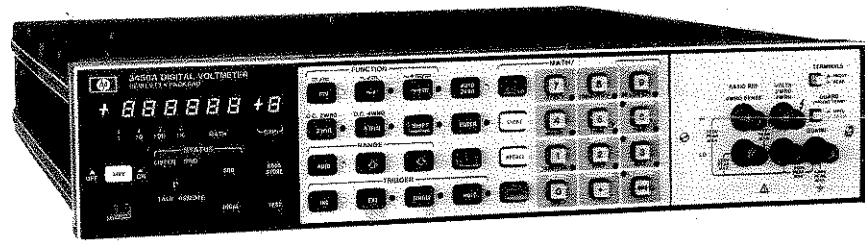



HEWLETT
PACKARD

OPERATING MANUAL

MODEL 3456A

DIGITAL VOLTMETER

SERIAL NUMBERS

This manual applies directly to instruments with a serial number prefix of 2201.

Instruments with a prefix of 2015, and serial numbers 2015A04595 and below, refer to Section VII (Manual Changes) of this manual. For information on instruments with a prefix other than listed in Section VII and on the title page, refer to the manual change sheet.

NOTICE

This Manual is a duplication of Sections I through III of your Operating and Service Manual

Keep with Instrument

WARNING

To help minimize the possibility of electrical fire or shock hazards, do not expose this instrument to rain or excessive moisture.

Manual Part No. 03456-90006



CERTIFICATION

Hewlett-Packard Company certifies that this product met its published specifications at the time of shipment from the factory. Hewlett-Packard further certifies that its calibration measurements are traceable to the United States National Bureau of Standards, to the extent allowed by the Bureau's calibration facility, and to the calibration facilities of other International Standards Organization members.

WARRANTY

This Hewlett-Packard instrument product is warranted against defects in materials and workmanship for a period of one year from date of shipment [except that in the case of certain components listed in Section I of this manual, the warranty shall be for the specified period]. During the warranty period, Hewlett-Packard Company will, at its option, either repair or replace products which prove to be defective.

For warranty service or repair, this product must be returned to a service facility designated by -hp-. Buyer shall prepay shipping charges to -hp- and -hp- shall pay shipping charges to return the product to Buyer. However, Buyer shall pay all shipping charges, duties, and taxes for products returned to -hp- from another country.

Duration and conditions of warranty for this instrument may be superceded when the instrument is integrated into (becomes a part of) other -hp- instrument products.

Hewlett-Packard warrants that its software and firmware designated by -hp- for use with an instrument will execute its programming instructions when properly installed on that instrument. Hewlett-Packard does not warrant that the operation of the instrument, or software, or firmware will be uninterrupted or error free.

LIMITATION OF WARRANTY

The foregoing warranty shall not apply to defects resulting from improper or inadequate maintenance by Buyer, Buyer-supplied software or interfacing, unauthorized modification or misuse, operation outside of the environmental specifications for the product, or improper site preparation or maintenance.

NO OTHER WARRANTY IS EXPRESSED OR IMPLIED. HEWLETT-PACKARD SPECIFICALLY DISCLAIMS THE IMPLIED WARRANTIES OF MERCHANTABILITY AND FITNESS FOR A PARTICULAR PURPOSE.

EXCLUSIVE REMEDIES

THE REMEDIES PROVIDED HEREIN ARE BUYER'S SOLE AND EXCLUSIVE REMEDIES. HEWLETT-PACKARD SHALL NOT BE LIABLE FOR ANY DIRECT, INDIRECT, SPECIAL, INCIDENTAL, OR CONSEQUENTIAL DAMAGES, WHETHER BASED ON CONTRACT, TORT, OR ANY OTHER LEGAL THEORY.

ASSISTANCE

Product maintenance agreements and other customer assistance agreements are available for Hewlett-Packard products.

For any assistance, contact your nearest Hewlett-Packard Sales and Service Office. Addresses are provided at the back of this manual.

MANUAL CHANGES

-hp- MODEL 3456A

DIGITAL VOLTMETER

Manual Part No. 03456-90006

ERRATA

Page 1-1, Paragraph 1-15. Change the 3456A options to the following:

- Option 050: for 50Hz Power Source
- Option 060: for 60Hz Power Source
- Option 907: Front Handle Kit
- Option 908: Rack Mount Kit
- Option 909: Front Handle and Rack Mounting Kit
- Option 910: Additional Set of Manuals

Page 1-1, Paragraph 1-17: Change the fuse rating in the paragraph from "3/8" amp to 1/4 amp.

Page 1-2, Table 1-1. Change the sentence under "Filter On" to the following:

Rejection is > 60dB at 50Hz. Add 2 μ V for 0.1V, 1.0V, and 100V ranges and 200 μ V for 10V and 1000V ranges.

Page 1-3, Table 1-1. Change the "< 75pF" Input Impedance in the "Input Characteristics" table under AC RMS VOLTAGE to "< 90pF".

Page 1-7, Table 1-1. Under THERMISTOR ($^{\circ}$ C) change the information as follows:

THERMISTOR ($^{\circ}$ C): Converts resistance of thermistor -hp- Part No. 0837-0164 to temperature in $^{\circ}$ C.

Output range: - 80 to 150 $^{\circ}$ C
Accuracy: - 75 \leq T \leq + 130 $^{\circ}$ C: \pm .06 $^{\circ}$ C max.
- 80 \leq T \leq + 150 $^{\circ}$ C: \pm .15 $^{\circ}$ C max.

Page 1-8, Table 1-1. Change the information under "Power" to the following:

Power: 100/120/220/240V + 5%, - 10% 48Hz to 400Hz
45VA max.

Page 2-1, Table 2-1. Change all fuse and current values in the table from "750mA" and "375mA" to "500mA" and "250mA", respectively.

Page 3-3, Figure 3-1. Change the fuse rating in step 29 in Figure 3-1 from ".75A" and "500mA" to "500mA" and ".375A" to "250mA".

Page 3-27. Add the following note after paragraph 3-194.

NOTE

The "SW0" and "SW1" codes are only used to determine in which position the Front/Rear switch is in. They are NOT used to set the switch to a certain position.

Page A-6, Figure A-8. Change the "REN" line in the table from "T" to "F".

CHANGE NUMBER 1. Applies to all Serial Numbers.

Table 1-1. Add the information in Table C-1 to the end of Table 1-1. Specifications.

25 March 1985

Supplement A for 03456-90006

Table C-1. Specification Table Additions

SUPPLEMENTAL SPECIFICATIONS

3456A TRANSFER SPECIFICATIONS

Transfer Accuracy Constraints:

The measurements are the average of 100 readings at 10 PLC (Power Line Cycles).

Auto-Zero is on.

Measurements are made on the same range.

The same terminals are used for each measurement.

The 3456A has been warmed up at least 2 hours.

In general, the measurements must be made in accordance with good metrology practices. It is suggested to use pure copper wire, low thermal solder, twisted pair wire, and guarded measurements.

DC VOLTS

Transfer Accuracy: ± Number of Counts

1 Hour: ±0.5 degrees C.

Range	6 1/2 Digits (10 PLC)
0.1V	6 counts
1.0V	2 counts
10.0V	2 counts
100.0V	3 counts

24 Hours: ± 1 degree C.

Range	6 1/2 Digits (10 PLC)
0.1V	8 counts
1.0V	4 counts
10.0V	4 counts
100.0V	3 counts

Resistance:

Transfer Accuracy: ± Number of Counts. All measurements are made with 4-wire ohms offset compensation.

1 Hour: ±0.5 degrees C.

Range	6 1/2 Digits (10 PLC)
100 ohms	5 counts
1K ohms	3 counts
10K ohms	3 counts
100K ohms	4 counts

24 Hours: ± 1 degree C.

Range	6 1/2 Digits (10 PLC)
100 ohms	7 counts
1K ohms	5 counts
10K ohms	5 counts
100K ohms	6 counts

AC Volts:

Transfer Accuracy: dc component < 10% of ac component.

Maximum voltage ≤ 500Vrms. All measurements made with Filter On. Input voltage > 1% of full scale.

1 Hour: ±0.5 degrees C.

Frequency	6 1/2 Digits (10 PLC)
30Hz - 20KHz	190 counts
20KHz - 50KHz	240 counts
50KHz - 100KHz	270 counts

24 Hours: ± 1 degree C.

Frequency	6 1/2 Digits (10 PLC)
30Hz - 20KHz	220 counts
20KHz - 50KHz	285 counts
50KHz - 100KHz	310 counts

Table C-1. Specification Table Additions (Cont'd)

SUPPLEMENTAL SPECIFICATIONS

AC Volts:

3456A TRANSFER SPECIFICATIONS

For input voltages 1mV to 10mV:

1 Hour: ± 0.5degrees C.

Frequency	6 1/2 Digits (10 PLC)
30Hz - 20KHz	205 counts
20KHz - 50KHz	255 counts
50KHz - 100KHz	285 counts

24 Hours: 1 degree C.

Frequency	6 1/2 Digits (10 PLC)
30Hz - 20KHz	250 counts
20KHz - 50KHz	315 counts
50KHz - 100KHz	340 counts

LOW LEVEL AND LOW FREQUENCY AC SPECIFICATIONS

Low Frequency Measurements Accuracy: ± (1% of Reading + Number of Counts). 10Hz to 20K Hz, Filter On, Auto-Zero On, > 1% of full scale, dc component < 10% of ac component. For inputs ≥ 500Vrms add 0.07% of reading to the specifications.

24 Hours: 23 degrees C ± 1 degree C for all ranges.

6 1/2 Digit (≥ 1 PLC)	.45 + 390
5 1/2 Digit (0.1 PLC)	.46 + 54
4 1/2 Digit (0.01 PLC)	.51 + 6

90 days: 23 degrees C ± 5 degrees C.

6 1/2 Digit (≥ 1 PLC)	.47 + 520
5 1/2 Digit (0.1 PLC)	.48 + 90
4 1/2 Digit (0.01 PLC)	.56 + 10

> 90 Days: 23 degrees C ± 5 degrees C (5 1/2 Digit)

Add ± (0.004% of Reading + 12 counts)/Month to 90 day accuracy. For 6 1/2 Digits, multiply counts by 10. for 4 1/2 Digits, multiply by 0.1.

24 Hours: 23 degrees C ± 1 degree C.

Integration Time in Power Line Cycles (PLC)	Frequency in Hz					
	Filter Off		400 to 20K	20K to 50K	50K to 100K	100K to 250K
	10 to 20	20 to 30	30 to 20K	20K to 50K	50K to 100K	100K to 250K
6 1/2 Digits (>= 1 PLC)	.45 + 490	.33 + 400	.05 + 650	.15 + 1600	.53 + 2800	5.0 + 6400
5 1/2 Digits (0.1 PLC)	.46 + 66	.34 + 45	.06 + 67	.16 + 162	.54 + 282	5.0 + 665
4 1/2 Digits (0.01 PLC)	.51 + 9	.39 + 8	.11 + 10	.21 + 20	.59 + 32	5.1 + 68

90 Days: 23 degrees C ± 5 degrees C.

Integration Time in Power Line Cycles (PLC)	Frequency in Hz					
	Filter Off		400 to 20K	20K to 50K	50K to 100K	100K to 250K
	10 to 20	20 to 30	30 to 20K	20K to 50K	50K to 100K	100K to 250K
6 1/2 Digits (>= 1 PLC)	.47 + 1020	.35 + 600	.07 + 1200	.17 + 2200	.55 + 3400	5.0 + 7000
5 1/2 Digits (0.1 PLC)	.48 + 142	.36 + 65	.08 + 125	.18 + 225	.56 + 340	5.0 + 705
4 1/2 Digits (0.01 PLC)	.56 + 15	.41 + 10	.13 + 14	.23 + 24	.61 + 36	5.1 + 72

> 23 degrees C ± 5 degrees C (5 1/2 Digit)

Add ± (0.004% of Reading + 12 counts)/Month to 90 day accuracy. For 6 1/2 Digits, multiply counts by 10. for 4 1/2 Digits, multiply by 0.1.

Temperature Coefficient: (% of Reading + Number of Counts)/degree C (5 1/2 Digits). ± (.008 + 15)/degrees C for dc component < 10% ac component. Otherwise add ± (.008 + 20)/degrees C. For 6 1/2 Digit, multiply counts by 10. For 4 1/2 Digit, multiply counts by 0.1.

CHANGE NO. 2. Applies to Serial Prefix 2512 and Above

Title Page. Add the following note to the title page.



Your instrument may have either metric or english hardware. DO NOT intermix the different hardware or damage to the instrument may result. Follow the cautions in the manual that pertain to the different hardware. Contact your local HP Office if more information is needed.

Section I, Paragraph 1-15. Change the paragraph to the following:

1-15. The following options are available for use with the HP 3456A.

Option 350: for 50 Hz Power Source

Option 360: for 60 Hz Power Source

Option 907: Front Handle Kit

(For Serial Prefix 2201 and below, use HP P/N 5061-0088.

For Serial Prefix 2512 and above, use HP P/N 5061-9688)

Option 908: Rack Mounting Kit

(For Serial Prefix 2201 and below, use HP P/N 5061-0074.

For Serial Prefix 2512 and above, use HP P/N 5061-9674)

Option 909: Front Handle and Rack Mounting Kit

(For Serial Prefix 2201 and below, use HP P/N 5061-0075.

For Serial Prefix 2512 and above, use HP P/N 5061-9675)



Your instrument may have either metric or english cabinet hardware. DO NOT intermix the different hardware or damage to the instrument's frame and cabinet may result. For instruments with serial prefix 2512 and above use metric handle/rack mounting hardware, as listed above. For older instruments with serial prefix 2201 and below, use english handle/rack mounting hardware also as listed above. Contact your local HP Office if more information is needed.

TABLE OF CONTENTS

Section	Page	Section	Page
I. GENERAL INFORMATION	1-1	III. OPERATION (Cont'd)	
1-1. Introduction	1-1	3-67. Settling Delay	3-11
1-5. Description	1-1	3-69. Optimizing the Reading Rate	3-11
1-8. Specifications	1-1	3-71. Math Feature	3-11
1-11. Instrument and Manual Identification	1-1	3-75. %Error	3-14
1-14. Options	1-1	3-78. Scale	3-14
1-16. Accessories Supplied	1-1	3-81. Pass/Fail (Limit Test)	3-14
1-18. Accessories Available	1-2	3-84. dB	3-15
1-20. Safety Consideration	1-2	3-87. dBm	3-15
1-22. Recommended Test Equipment	1-2	3-90. Null	3-15
		3-93. Thermistor	3-15
Section II. INSTALLATION	2-1	3-96. Statistics	3-16
2-1. Introduction	2-1	3-101. Reading Storage	3-17
2-3. Initial Inspection	2-1	3-106. Voltmeter Complete	3-18
2-5. Preparation for Use	2-1	3-108. Guarding	3-18
2-6. Power Requirements	2-1	3-109. General	3-18
2-8. Line Voltage Selection	2-1	3-111. Guarding Information	3-18
2-10. Power Cords and Receptacles	2-1	3-113. Front/Rear Switch Lockout	3-18
2-12. Grounding Requirements	2-1	3-115. Remote Operation	3-18
2-14. Bench Use	2-2	3-116. General	3-18
2-16. Rack Mounting	2-2	3-118. HP-IB Description (in Appendix A)	3-18
2-18. Interface Connections	2-2	3-120. 3456A Response to Bus Message	3-18
2-20. Address Selection	2-2	3-122. Data	3-19
2-23. External Trigger	2-4	3-124. Trigger	3-19
2-25. Voltmeter Complete Connector	2-4	3-126. Clear	3-19
2-27. Environmental Requirements	2-4	3-128. Remote	3-19
2-28. Operating and Storage Temperature	2-4	3-130. Local	3-19
2-31. Humidity	2-4	3-132. Local Lockout	3-19
2-33. Altitude	2-4	3-134. Clear Lockout and Set Local	3-19
2-35. Repacking for Shipment	2-4	3-136. Require Service (SRQ)	3-19
		3-140. Status Byte	3-20
Section III. OPERATION	3-1	3-144. Status Bit	3-21
3-1. Introduction	3-1	3-146. Pass Control	3-21
3-5. Pre-Operating Instructions	3-1	3-148. Abort (Interface Clear)	3-21
3-9. General Operating Characteristics	3-1	3-150. 3456A Addressing	3-21
3-11. Turn-On and Warm-up	3-1	3-154. Talk-Only (No Controller)	3-22
3-13. Reset	3-1	3-156. 3456A HP-IB Programming	3-22
3-17. Self Test Operation	3-3	3-159. Algorithm	3-22
3-19. Display	3-4	3-163. Programming the 3456A over the HP-IB	3-23
3-21. Error Messages	3-4	3-165. Program Codes (Data received by the 3456A)	3-23
3-23. Operating Characteristics	3-4	3-167. Storing into Registers (Y, Z, Delay, etc.) over the HP-IB	3-23
3-25. DC Voltage Measurement	3-4	3-169. Programming the SRQ Mask	3-25
3-28. AC Voltage Measurement	3-5	3-172. 3456A's Measurement DATA (Data sent by the 3456A)	3-25
3-30. AC+DC Measurement	3-5	3-174. ASCII Format	3-25
3-33. Resistance Measurement	3-5	3-178. Packed Format	3-25
3-37. Shift Operation	3-6	3-184. Reading the 3456A's Output Data	3-26
3-39. Ratio	3-6	3-186. Disabling the End or Identify (EOI) Statement	3-26
3-41. Offset Compensated Ohms Measurement (O.C. Ohms)	3-7	3-188. System Output Mode	3-26
3-44. Ranging	3-7	3-191. Home Command	3-27
3-46. Instrument Trigger Modes	3-8	3-193. Front/Rear Switch Position	3-27
3-48. Autozero	3-8	3-195. Complete Program Example	3-27
3-50. Autozero Effects on 4-Wire Ohms Measurement	3-8	3-198. Front Panel SRQ	3-28
3-52. Analog Filter	3-9	3-200. Instrument Program Memory Operation	3-28
3-54. Numbered Keyboard Operations	3-9	Data Ready	3-29
3-56. Storing Into Registers	3-9	3-208. 3456A's Numeric Entry Format and other Input Considerations	3-29
3-61. Number of Power Line Cycles Integrated	3-11	3-211. Operator's Check	3-29
3-63. Digits Displayed	3-11		
3-65. Number of Readings per Trigger	3-11		

TABLE OF CONTENTS (Cont'd)

APPENDICES
Appendix A
Appendix B

LIST OF TABLES

Table	Page
1-1. Specifications	1-2
1-2. Recommended Test Equipment	1-8
3-1. Error Messages	3-4
3-2. Registers and Math Listing	3-10
3-3. Default Delays	3-11
3-4. Optimizing Reading Rate	3-12
3-5. Interface Functions	3-18
3-6. 3456A Clear, Home and Reset Difference	3-19
3-7. Status Byte Definition	3-20
3-8. 3456A Address Codes	3-22
3-9. 3456A Program Codes	3-24

LIST OF ILLUSTRATIONS

Figure	Page
2-1. Line Voltage Selection	2-1
2-2. Power Cables	2-2
2-3. Typical HP-IB System Interconnections	2-3
2-4. HP-IB Connector	2-3
2-5. 3456A Address Switch	2-4
3-1. Front and Rear Panel Features	3-2
3-2. Front Panel Display Area	3-3
3-3. 3456A Display	3-4
3-4. Front Panel Voltmeter Configuration Area	3-4
3-5. Ohms Connection	3-5
3-6. Ratio Connection	3-6
3-7. Typical Ratio Measurement	3-7
3-8. Front Panel Numbered Keyboard Area	3-9
3-9. Guard Connections	3-19
3-10. Status Byte	3-21



Herstellerbescheinigung

Hiermit wird bescheinigt, daß das Gerät/System HP 3456A
in Übereinstimmung mit den Bestimmungen von Postverfügung 1046/84 funkentstört ist.

Der Deutschen Bundespost wurde das Inverkehrbringen dieses Gerätes/Systems angezeigt und die Berechtigung zur Überprüfung der Serie auf Einhaltung der Bestimmungen eingeräumt.

Zusatzinformation für Meß- und Testgeräte

Werden Meß- und Testgeräte mit ungeschirmten Kabeln und/oder in offenen Meßaufbauten verwendet, so ist vom Betreiber sicherzustellen, daß die Funk-Entstörbestimmungen unter Betriebsbedingungen an seiner Grundstücksgrenze eingehalten werden.

Manufacturer's declaration

This is to certify that the equipment HP 3456A
is in accordance with the Radio Interference Requirements of Directive FTZ 1046/84. The German Bundespost was notified that this equipment was put into circulation, the right to check the series for compliance with the requirements was granted.

Additional Information for Test- and Measurement Equipment

If Test- and Measurement Equipment is operated with unshielded cables and/or used for measurements on open set-ups, the user has to assure that under operating conditions the Radio Interference Limits are still met at the border of his premises.

SAFETY SUMMARY

The following general safety precautions must be observed during all phases of operation, service, and repair of this instrument. Failure to comply with these precautions or with specific warnings elsewhere in this manual violates safety standards of design, manufacture, and intended use of the instrument. Hewlett-Packard Company assumes no liability for the customer's failure to comply with these requirements. This is a Safety Class 1 instrument.

GROUND THE INSTRUMENT

To minimize shock hazard, the instrument chassis and cabinet must be connected to an electrical ground. The instrument is equipped with a three-conductor ac power cable. The power cable must either be plugged into an approved three-contact electrical outlet or used with a three-contact to two-contact adapter with the grounding wire (green) firmly connected to an electrical ground (safety ground) at the power outlet. The power jack and mating plug of the power cable meet International Electrotechnical Commission (IEC) safety standards.

DO NOT OPERATE IN AN EXPLOSIVE ATMOSPHERE

Do not operate the instrument in the presence of flammable gases or fumes. Operation of any electrical instrument in such an environment constitutes a definite safety hazard.

KEEP AWAY FROM LIVE CIRCUITS

Operating personnel must not remove instrument covers. Component replacement and internal adjustments must be made by qualified maintenance personnel. Do not replace components with power cable connected. Under certain conditions, dangerous voltages may exist even with the power cable removed. To avoid injuries, always disconnect power and discharge circuits before touching them.

DO NOT SERVICE OR ADJUST ALONE

Do not attempt internal service or adjustment unless another person, capable of rendering first aid and resuscitation, is present.

DO NOT SUBSTITUTE PARTS OR MODIFY INSTRUMENT

Because of the danger of introducing additional hazards, do not install substitute parts or perform any unauthorized modification to the instrument. Return the instrument to a Hewlett-Packard Sales and Service Office for service and repair to ensure that safety features are maintained.

DANGEROUS PROCEDURE WARNINGS

Warnings, such as the example below, precede potentially dangerous procedures throughout this manual. Instructions contained in the warnings must be followed.

WARNING

Dangerous voltages, capable of causing death, are present in this instrument. Use extreme caution when handling, testing, and adjusting.

SAFETY SYMBOLS

General Definitions of Safety Symbols Used On Equipment or In Manuals.



Instruction manual symbol: the product will be marked with this symbol when it is necessary for the user to refer to the instruction manual in order to protect against damage to the instrument.



Indicates dangerous voltage (terminals fed from the interior by voltage exceeding 1000 volts must be so marked).

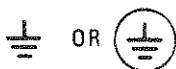

Protective conductor terminal. For protection against electrical shock in case of a fault. Used with field wiring terminals to indicate the terminal which must be connected to ground before operating equipment.



Low-noise or noiseless, clean ground (earth) terminal. Used for a signal common, as well as providing protection against electrical shock in case of a fault. A terminal marked with this symbol must be connected to ground in the manner described in the installation (operating) manual, and before operating the equipment.

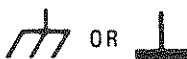

Frame or chassis terminal. A connection to the frame (chassis) of the equipment which normally includes all exposed metal structures.



Alternating current (power line).



Direct current (power line).



Alternating or direct current (power line).

WARNING

The WARNING sign denotes a hazard. It calls attention to a procedure, practice, condition or the like, which, if not correctly performed or adhered to, could result in injury or death to personnel.

CAUTION

The CAUTION sign denotes a hazard. It calls attention to an operating procedure, practice, condition or the like, which, if not correctly performed or adhered to, could result in damage to or destruction of part or all of the product.

NOTE :

The NOTE sign denotes important information. It calls attention to procedure, practice, condition or the like, which is essential to highlight.

SECTION I

GENERAL INFORMATION

1-1. INTRODUCTION.

1-2. The information contained in this Manual is for the Installation, Operation, HP-IB Programming and Service of the Hewlett-Packard Model 3456A Digital Voltmeter.

NOTE

HP-IB is Hewlett-Packard's implementation of IEEE Std. 488-1975, "Standard Digital Interface for Programmable Instrumentation."

1-3. The Installation, Operating, and HP-IB Programming information in this Manual is also contained in the Operating Manual.

1-4. This section in the Manual contains general information concerning the 3456A Digital Voltmeter. Included are instrument description, specifications, supplemental characteristics, instrument and manual identification, options, accessories, and other information on the instrument.

1-5. DESCRIPTION.

1-6. The Hewlett-Packard Model 3456A is a versatile Digital Voltmeter with ac, dc, ohms, and various math functions. This voltmeter is an excellent bench meter and since it is remotely programmable it is an exceptional system measurement device. Other features for which you may have some good uses are the selection of power line cycles integrated, the selection of certain number of readings/trigger, settling delay, ratio, and other unique and useful functions.

1-7. The 3456A also employs a feature called AUTO ZERO. This feature of the instrument is very useful for good stability. The internal reference device and reference resistors are also selected for good accuracy and stability. Another good feature is the TEST function of the 3456A. With this function the instrument's operation can be partially verified for correct operation by the operator.

1-8. SPECIFICATIONS.

1-9. Specifications of the 3456A are the performance

characteristics of the instrument which are warranted. These specifications are listed in Table 1-1, and are the performance standards or limits against which the instrument can be tested. Included in Table 1-1 are also some supplemental characteristics of the 3456A and should be considered as additional and general information for you, the user. Because of the many operational capabilities of the 3456A, exercise care when determining the instrument's specifications.

1-10. Any changes in the specifications due to manufacturing changes, design, or traceability to the National Bureau of Standards will be covered in a manual change supplement or revised manual pages. The specifications listed here supercede any previously published.

1-11. INSTRUMENT AND MANUAL IDENTIFICATION.

1-12. Instrument identification is by a serial number located on the rear panel of the instrument. Hewlett-Packard uses a two-part serial number. The first part (prefix) identifies a series of instruments and the last part (suffix) identifies a particular instrument within a series. A letter between the prefix and suffix identifies the country in which the 3456A is manufactured.

1-13. This Manual applies to instruments with serial number indicated on the title page. Updating of the manual is accomplished either by a change sheet or revised pages.

1-14. OPTIONS.

1-15. The following options are available for use with the 3456A:

- Option 350: for 50 Hz Power Source
- Option 360: for 60 Hz Power Source
- Option 907: Front Handle Kit
- Option 908: Rack Mounting Kit
- Option 909: Front Handle and Rack Mounting Kit
- Option 910: Additional Set of Manuals

1-16. ACCESSORIES SUPPLIED.

1-17. The 3456A is supplied with a 3/8 amp, 250V fuse for the 220V and 240V power line voltages.

1-18. ACCESSORIES AVAILABLE.

1-19. The following is a list of available accessories for the 3456A:

Accessory No.	Description
10631A	HP-IB Cable 1 Meter (39.37 in.)
10631B	HP-IB Cable 2 Meter (78.74 in.)
10631C	HP-IB Cable 4 Meter (157.48 in.)
10631D	HP-IB Cable 0.5 Meter (19.69 in.)
11000A	Test Leads, Dual Banana Both Ends
11002A	Test Leads, Dual Banana to Probe and Alligator
34111A	High Voltage Probe (40 kV dc)
44414A	4 Thermistors

1-20. SAFETY CONSIDERATION.

1-21. The 3456A is a safety class 1 instrument (provided with a protective earth connection). The instrument and manual should be reviewed for safety symbols and instructions before using.

1-22. RECOMMENDED TEST EQUIPMENT.

1-23. Required equipment to maintain the Model 3456A is listed in Table 1-2. Other equipment may be substituted if it meets the requirements listed in the table. The table is also repeated in Section IV of the Operating and Service Manual.

Table 1-1. Specifications.

DC VOLTAGE						
Input Characteristics						
Range	Maximum Reading (5 digit)	6 Digit	Resolution 5 Digit	4 Digit	Input Resistance	Maximum Input Voltage
0.1V	.119999V	100 nV	1 μ V	10 μ V	> 10 ¹⁰ Ω	± 1000V peak
1.0V	1.19999V	1 μ V	10 μ V	100 μ V	> 10 ¹⁰ Ω	
10.0V	11.9999V	10 μ V	100 μ V	1mV	> 10 ¹⁰ Ω	
100.0V	119.999V	100 μ V	1mV	10mV	10M Ω ± .5%	
1000.0V	1000.00V	1mV	10mV	100mV	10M Ω ± .5%	

Guard to Chassis: ± 500V peak
Guard to Low: ± 200V peak

Measurement Accuracy: ± (% of Reading + Number of Counts).
Auto-zero on and filter off.

24 hours: 23°C ± 1°C

Range	6 Digit (≥ 10 PLC*)	6 Digit (1 PLC)	5 Digit (.1 PLC)	4 Digit (.01 PLC)
0.1V	.0022 + 24	0.0024 + 32	0.007 + 14	0.06 + 3
1.0V	0.0009 + 4	0.0012 + 5	0.007 + 3	0.06 + 2
10.0V	0.0008 + 2	0.0011 + 3	0.007 + 2	0.06 + 2
100.0V	0.0011 + 3	0.0014 + 4	0.007 + 2	0.06 + 2
1000.0V ¹	0.0011 + 2	0.0013 + 3	0.007 + 2	0.06 + 2

90 Day: 23°C ± 5°C

Range	6 Digit (≥ 10 PLC)	6 Digit (1 PLC)	5 Digit (.1 PLC)	4 Digit (.01 PLC)
0.1V	0.0034 + 24	0.0035 + 32	0.008 + 14	0.06 + 3
1.0V	0.0024 + 4	0.0025 + 5	0.007 + 3	0.06 + 2
10.0V	0.0023 + 2	0.0024 + 3	0.007 + 2	0.06 + 2
100.0V	0.0026 + 3	0.0027 + 4	0.007 + 2	0.06 + 2
1000.0V ¹	0.0024 + 2	0.0025 + 3	0.007 + 2	0.06 + 2

¹Add .012 $\left(\frac{\text{Input Voltage}}{1000}\right)^2$ % to % reading.

> 90 days: 23°C ± 5°C
Add ± .0006% of Reading/month to 90 day accuracy.

Table 1-1. Specifications (Cont'd).

Temperature Coefficient: (5 digit)² ± (% of Reading + Number of Count)/°C

Range	0.1V	1.0V	10.0V	100.0V	1000.0V
Temp. Coef.	0.0002 + 0.2	0.0002 + 0.02	.0002 + .002	0.0002 + 0.02	0.0002 + 0.02

Auto-Zero OFF: (5 digit)²

For a stable environment ± 1°C, add 10 counts for .1V range, 1 count for 1V and 100 ranges, and .1 count for 10V and 1000V ranges.

Filter ON: Rejection is > 60 dB at 50 Hz. Add 2µV for .1V, 1.0V and 10V range and 200 µV for 10V and 1000V range.

²For 6 digits, multiply counts by 10

For 4 digits, multiply counts by .1

Response Time:

Filter OFF - For default delay (0.0 seconds), error is < .0005 % of input voltage step.

Filter ON: For default delay (.65 seconds), error is < .01% of input voltage step.

Integration Time in Power Line Cycles (PLC)	Noise Rejection (dB)		
	AC ^{3,4} NMR	AC ^{3,4} ECMR ⁴	DC ECMR ⁴
.01 PLC or .1 PLC	0	90	140
> 1 PLC	60	150	140
> 1 PLC with Filter	120	160	140

*Integration in POWER LINE CYCLES

³For 50, 60 Hz (depending on option) ± .09%.

⁴1 KΩ unbalance in Lo

AC RMS VOLTAGE

Input Characteristics

Range	Maximum Reading (5 Digit)	6 Digit	Resolution 5 Digit	4 Digit	Input Impedance	Maximum Input Voltage
1.0V	1.19999V	1 µV	10 µV	100 µV	1MΩ ± .5% shunted by < 75pF	± 1000V peak (700V rms) 10 ⁸ VHZ
10.0V	11.9999V	10 µV	100 µV	1mV		
100.0V	119.999V	100 µV	1mV	10mV		
1000.0V	700.00V	1mV	10mV	100mV		

Guard to Chassis: ± 500V peak

Guard to Low: ± 200V peak

Measurement Accuracy: ± (% of Reading + Number of Counts)

Auto-zero on, > 1% of full scale, and DC component < 10% of AC Component.

For inputs > 500V rms add .07% of reading.

24 hours: 23°C ± 1°C

Integration Time in Power Line Cycles (PLC)	Frequency in Hz				
	Filter Off→ 20 to 30	400-20k 30-20k	20k to 50k 20k to 50k	50k to 100k 50k to 100k	¹ 100k to 250k ¹ 100k to 250k
6 Digit (≥ 1 PLC)	.33 + 300	.05 + 550	.15 + 1500	.53 + 2700	5.0 + 6300
5 Digit (.1 PLC)	.34 + 33	.06 + 55	.16 + 150	.54 + 270	5.0 + 630
4 Digit (.01 PLC)	.39 + 5	.11 + 7	.21 + 17	.59 + 29	5.1 + 65

Table 1-1. Specifications (Cont'd).

90 day: 23°C ± 5°C

Integration Time in Power Line Cycles (PLC)	Frequency in Hz				
	Filter Off— 20 to 30	400-20k 30-20k	20k to 50k 20k to 50k	50 k to 100k 50k to 100k	¹ 100k to 250k ¹ 100k to 250k
6 Digit (≥ 1 PLC)	.35 + 500	.07 + 700	.17 + 1700	.55 + 2900	5.0 + 6500
5 Digit (.1 PLC)	.36 + 53	.08 + 73	.18 + 173	.56 to 293	5.0 + 653
4 Digit (.01 PLC)	.41 + 7	.13 + 9	.23 + 19	.61 + 31	5.1 + 67

¹Frequencies > 100 kHz are specified for 1.0V and 10V ranges only.

> 90 day: 23°C ± 5°C (5 digit)²

Add ± (.004% of Reading + 12 counts)/month to 90 day accuracy.

Temperature Coefficient: (5 digit)²

± (% of Reading + Number of Counts)/°C

± (.008 + 6)/°C for DC component < 10% AC component

± (.008 + 12)/°C otherwise

²For 6 digit, multiply counts by 10.

For 4 digit, multiply counts by .1.

DC Component > 10% of AC Component: (5 digit)²

Add ± (.05% of Reading + 50 counts) to accuracy.

Crest Factor: > 7 at full scale.

Common Mode Rejection (1kΩ unbalance in Lo): > 90 dB DC to 60 Hz

Auto-Zero Off: For stable environment ± 1°C no accuracy change.

Default Delays:

Filter Off - .06 seconds

Filter On - .80 seconds

Response Time: For default delay, error is < .1% of input voltage step.

RESISTANCE

Input Characteristics

Range	Maximum Reading (5 Digit)	6 Digit	Resolution 5 Digit	4 Digit	Current Through Unknown	Maximum Valid Reading Voltage	Maximum Open Circuit Voltage
100Ω	119.999Ω	100μΩ	1mΩ	10mΩ	1mA	1.2V	5.5V
1kΩ	1199.99Ω	1mΩ	10mΩ	100mΩ	1mA	1.2V	5.5V
10kΩ	11.9999kΩ	10mΩ	100mΩ	1Ω	100μA	1.2V	5.5V
100kΩ	119.999kΩ	100mΩ	1Ω	10Ω	50μA	6V	9.5V
1MΩ	1199.99kΩ	1Ω	10Ω	100Ω	5μA	6V	9.5V
10MΩ	11.9999MΩ	10Ω	100Ω	1kΩ	500nA	6V	9.5V
100MΩ	119.999MΩ	100Ω	1kΩ	10kΩ	≤ 500nA ¹	5V	5.5V
1GΩ	1000.00MΩ	1kΩ	10kΩ	100kΩ	≤ 500nA ¹	5V	5.5V

¹Ohms source is a 500nA current source in parallel with a 10MΩ resistance.

Non-destructive overload: 350V peak.

Table 1-1. Specifications (Cont'd).

Measurement Accuracy: \pm (% of Reading + Number of Counts)
 Auto-Zero on, filter off, and 4-wire ohms.

24 hours: 23°C \pm 1°C

Range	6 Digit (\geq 10 PLC)	6 Digit (1 PLC)	5 Digit (.1 PLC)	4 Digit (.01 PLC)
100 Ω	0.003 + 24	0.003 + 32	0.009 + 14	0.07 + 3
1k Ω	0.002 + 4	0.003 + 5	0.008 + 3	0.07 + 2
10k Ω	0.002 + 4	0.003 + 5	0.008 + 3	0.07 + 2
100k Ω	0.002 + 2	0.003 + 3	0.008 + 2	0.07 + 2
1M Ω	0.006 + 2	0.006 + 3	0.012 + 2	0.07 + 2
10M Ω	0.041 + 2	0.041 + 3	0.07 + 2	0.12 + 2
100M Ω	1.3 + 1	1.3 + 1	1.5 + 1	1.5 + 1
1G Ω	11 + 1	11 + 1	13 + 1	13 + 1

90 days: 23°C \pm 5°C

Range	6 Digit (\geq 10 PLC)	6 Digit (1 PLC)	5 Digit (.1 PLC)	4 Digit (.01 PLC)
100 Ω	0.004 + 24	0.004 + 32	0.01 + 14	0.07 + 3
1k Ω	0.003 + 4	0.004 + 5	0.009 + 3	0.07 + 2
10k Ω	0.003 + 4	0.004 + 5	0.009 + 3	0.07 + 2
100k Ω	0.003 + 2	0.004 + 3	0.009 + 2	0.07 + 2
1M Ω	0.007 + 2	0.007 + 3	0.013 + 2	0.07 + 2
10M Ω	0.042 + 2	0.042 + 3	0.07 + 2	0.12 + 2
100M Ω	1.8 + 1	1.8 + 1	2.0 + 1	2.0 + 1
1G Ω	16 + 1	16 + 1	18 + 1	18 + 1

> 90 days: 23°C \pm 5°C
 Add \pm .0004% of Reading/month to 90 day accuracy.

2-Wire Ohms Accuracy: Same as 4-wire ohms except add < .2 ohm offset.

Auto-Zero Off Accuracy: (5 digit)²
 For a stable environment \pm 1°C, add 10 counts for 100 Ω range, 1 count for 1k Ω range and 10k Ω ranges, and .2 counts for \geq 100k Ω ranges. Changes in lead resistance are not corrected for a 4-wire ohms.

²For 4 digit, multiply counts by .1.
 For 6 digit, multiply counts by 10.

Range	Maximum Lead Resistance for 4-Wire Ohms	Maximum Offset Voltage for Offset Compensated Ohms	Default Delay in Seconds
100 Ω	10 Ω	.01V	0
1k Ω	100 Ω	.1V	0
10k Ω	1000 Ω	.1V	0
100k Ω	1000 Ω	.5V	.001
1M Ω	1000 Ω		.008
10M Ω	1000 Ω		.08
100M Ω	1000 Ω		.08
1G Ω	1000 Ω		.08

Offset Compensated Ohms Accuracy: Same as 2-wire and 4-wire except maximum reading may be reduced by 9% for large offset voltages. 100 Ω - 100k Ω range are used.

Response Time: With default delay and < 200pF of capacitance, first reading is in specification.

Filter is not operational in ohms.

Table 1-1. Specifications (Cont'd).

Temperature Coefficient: (5 digit)² ± (% of Reading + Number of Counts)/°C

Range	100Ω	1kΩ 10kΩ 100kΩ	1MΩ	10MΩ	100MΩ	1GΩ
T.C.	.0004 +.2	.0004 +.02	.0004 +.004	.0010 +.004	.16 +0	1.6 +0

RATIO

Type: DC/DC, AC/DC, or (AC + DC)/DC

Method: 4-Wire with Volts Lo input common.

$$\text{Ratio} = \frac{\text{Signal Voltage}}{\text{Ref. Hi Voltage} - \text{Ref. Lo Voltage}}$$

Signal Measurement: Same as DC Volts, or AC + DC Volts.

Reference Measurement: Automatically selects .1V, 1V, or 10V DC Volts range and a 0.0 msec. settling time. Filter is off.

Maximum Reference Voltage:

- Ref. Hi: ± 12V
- Ref. Lo: ± 9% of Ref. Hi.
- Ref. Hi-Ref. Lo: ± 11.9999V
- Protection: ± 350V peak

Accuracy: Total % signal error + total % reference error (same as .1V, 1V, or 10V DC volts)

READING RATE

Reading rates are with autorange, math, display and filter off. Output is to internal memory using internal trigger and packed Mode. Packed output in place of internal memory adds .35 msec; ASCII output adds 2.3 msec.

Rates vs. Integration Time and Auto-Zero: DC Volts and 100Ω thru 10kΩ ranges with default (-0.0 sec.) delay. Also, AC or AC + DC Volts and 100kΩ thru 10MΩ ranges with 0.0 sec. delay.

Integration Time in Power Line Cycles (PLC)	Rates			
	Auto-Zero Off		Auto-Zero On	
	60 Hz	50 Hz	60 Hz	50 Hz
0.01	330	290	210	180
.10	210	180	120	100
1.00	48	40	25	20.8
10.00	5.8	4.8	2.9	2.4
100.00	.57	0.47	.29	0.24

Rates with 1 Power Line Cycle Integration and Default Delays.

	Rates	
	60 Hz	50 Hz
- DC Volts and 100Ω thru 10kΩ, Auto-zero Off	48.0	40.00
- DC Volts, Filter ON	1.48	1.47
- AC or AC + DC Volts, Auto-zero OFF	12.0	11.00
- AC or AC + DC Volts, Filter ON	1.2	0.95
- 100kΩ range, Auto-zero OFF	46.0	35.0
- 1MΩ range, Auto-zero OFF	34.0	28.0
- 10MΩ range, Auto-zero OFF	9.9	9.0
- 100MΩ and 1GΩ range, Auto-zero OFF	6.6	6.10
- DC/DC ratio	5.2	4.40
- Offset Compensated Ohms	10.0	9.00

Table 1-1. Specifications (Cont'd).

MATH FUNCTION SPECIFICATIONS

General: Math function specifications do not include error in X (instrument reading) or in entered values (R,L,U,Y,Z). Range of values input or output is $\pm (0.000000 \times 10^{-9}$ to 1999999×10^9). Out of range values send "LL" to display and $+ 1999999 \times 10^9$ to HP-IB.

PASS/FAIL: Displays: "HI" for values $>$ upper limit (U), "LO" for values $<$ lower limit (L), and X for values between the limits, with no introduced error.

SRQ mask can be programmed to respond to HI or LO conditions.

Maximum execution time: 20ms

STATISTICS:

$$\text{Mean (M)} = X_1 + \frac{1}{C} \sum_{i=1}^C (X_i - X_1)$$

$$\text{Variance (V)} = \frac{\sum_{i=1}^C (X_i - X)^2}{C - 1} - \frac{1}{C} \left[\sum_{i=1}^C (X_i - X_1) \right]^2$$

Maximum (U) and Minimum (L) are the most positive and negative instrument readings, respectively. X is displayed during calculation of statistics.

X_1 is the first reading taken after enabling statistics and is stored in the Z register. The number of readings taken (C) is stored in the count register.

$$\text{Accuracy of Mean: } < \pm \frac{C(U-L)}{10^{11}} + 1 \text{ LSD}$$

$$\text{Accuracy of Variance: } < \pm \frac{C(U-L)^2}{10^8} + 1 \text{ LSD}$$

Maximum execution time: 50ms

NULL: $X - X_1$ (X_1 is the first valid reading taken after enabling null and is stored in the Z register).

Maximum execution time: 15ms

dBm(R): $10 \log \frac{x^2/R}{1\text{mW}}$ R is the user-entered impedance.

Output range: -280 to +340 dBm

Accuracy: $\pm .001$ dBm

Maximum execution time: 150ms

THERMISTOR (°F): Converts resistance of thermistor HP0837-0164 to temperature in °F.

Output range: -112 to 302°F

Accuracy: $-103 \leq T \leq +266$ °F: ± 11 °F max.
 $-116 \leq T \leq +320$ °F: ± 27 °F max.

Maximum execution time: 150ms

THERMISTOR (°C): Converts resistance of thermistor HP0837-1064 to temperature in °C.

Output range: -80 to 150°C

Accuracy: $-75 \leq T \leq +130$ °C ± 06 °C max.
 $-80 \leq T \leq +150$ °C ± 15 °C max.

Maximum execution time: 100ms

SCALE: (X-Y)/Y

Accuracy: ± 1 LSD

Maximum execution time: 60ms

% ERROR: $100\% \times (X-Y)/Y$

Accuracy: ± 1 LSD

Maximum execution time: 60ms

dB: $20 \log \frac{X}{Y}$

Output Range: -620 to +620 dB

Accuracy: .001 dB

Maximum execution time: 100ms

MEMORY**Reading Store:**

- Can store up to 350 most recent readings.
- Can be recalled from the HP-IB interface or the front panel.

Program Memory:

- Can execute an internal program which controls instrument configuration and measurement sequence.
- Program is input from the HP-IB interface with up to 1400 ASCII characters.

Memory Size:

- Total size = 1400 bytes
- Memory used = 1 byte per ASCII character + 4 bytes per reading stored.

GENERAL

Voltmeter Control Functions: Description: The voltmeter control function in the math section of the front panel is designed to control the measurement parameters of the 3456A. Included in this front panel section is the:

- 1) Number of digits displayed.
- 2) Number of readings per trigger.
- 3) Delay time between readings.
- 4) Integration time in number of power line cycles (PLC).

Number of Digits Displayed allows selection of 3 to 6 digits displayed plus sign and exponent. The range of the display is $\pm 1,999,999 \pm 9$.

Number of Readings per Trigger allows selection of specific number of readings to be taken with just one trigger. The time between readings is controlled by the delay time selected.

Delay Time allows selection of the time between measurement cycles. It is provided to allow the selection of settling time. The range is from 0 to 999.999 sec. in 0.001/sec. increments. Accuracy is 1% of time selected.

Integration Time in Power Line Cycles allows the selection of the time for measurement integration. The units of integration time in power line cycles (PLC) apply for both 50 and 60 Hz power line frequencies. The range of integration time selection is from 0.01 to 100 power line cycles (PLC) per measurement.

Front-Rear Terminal Switch - On the front panel. Operated manually. Its status can be read via software.

Table 1-1. Specifications (Cont'd).

<p>The actual measurement time is a function of the integration time, the delay time, auto zero, filter, etc., voltmeter complete, external trigger, and function selected.</p> <p>Operating Temperature: 0 C to 50 C</p> <p>Warmup Time: One hour to meet all specifications</p> <p>Humidity Range: 95% R.H., 0 C to 40 C</p>	<p>Storage Temperature: -40 C to + 75 C</p> <p>Power: 100/120/240V + 5%, -10% 48 Hz to line operation 80VA; 220V ± 10% 48 Hz to line operation 80VA.</p> <p>Size: 88.9mm high x 425.5mm wide x 527.1mm deep (3½" high x 16¾" wide x 20¾" deep)</p> <p>Weight: Net 10.49 kg (23.13lbs.)</p>
---	--

Table 1-2. Recommended Test Equipment

Instrument	Critical Specification	Recommended Model	Use
DC Voltage Standard	Voltage: 10mV to 1000V Accuracy: ± .005%	Systron Donner Model M107	PAT
DC Transfer Standard	Output Voltages: 1V, 10V, 1.018V, 1.019V Accuracy: ± 5ppm Stability: ± .001% (30 Days)	Fluke Model 731B	PA
AC Calibrator	Frequency: 20 Hz to 250 kHz Output Level: 100mV to 1000V Accuracy: ± .1% Voltage Stability (6 mos.) ± .02%	Fluke Model 5200A and Model 5215A	PAT
Reference Divider	Division Ratio Accuracy: ± .001% Output Voltage Range: 1V to 1kV	Fluke Model 750A	PA
Resistance Standard	Resistance: 100Ω Accuracy: ± .0005%	Guildline Model 9330/100 or 9330A/100	P
	Resistance: 1kΩ Accuracy: ± .0005%	9330/1K or 9330A/1K	PA
	Resistance: 10kΩ Accuracy: ± .001%	9330/10K or 9330A/10K	PA
	Resistance: 100kΩ Accuracy: ± .001%	9330/100K or 9330A/100K	PA
	Resistance: 1MΩ Accuracy: ± .002%	9330/1M	PA
	Resistance: 10MΩ Accuracy: ± .01%	9330/10M	PA
	Resistance*: 1GΩ Accuracy: ± 2%	-hp- Part No. 03456-67902	P
	DC Null Voltmeter	Voltage Range: 1μV to 10V	-hp- Model 419A
Bus System Analyzer**	HP-IB Control Capability	-hp- Model 59401A	T
Desktop Computer	HP-IB Control Capability serves as printer for output data	-hp- Model 9825A, 9825B, 9835A, 9845B, or 85A	OT
Oscilloscope**	Bandwidth: DC to 100 MHz Sweep Time: 50ns to 20ms/div	-hp- Model 1740A	T
Digital Voltmeter**	Voltage Range: 100μV to 1000V Resolution: 1 μV	-hp- Model 3456A (or 3455A)	T
Resistors	Resistances: 1 kΩ ± 10%	-hp- Part No. 0684-1021	
Signature Analyzer**		-hp- Model 5004A	T
Test Program Cartridges*		-hp- Part Number 03456-10001 (9825A/B) 03456-10002 (9835A, 9845A/B) 03456-10003 (85A)	T

Table 1-2. Recommended Test Equipment (Cont'd).

Instrument	Critical Specification	Recommended Model	Use
Isolation Logic Test Jumper* HP-IB Signature Analysis Modules*,**		-hp- Part No. 03456-61602 -hp- Part Number 5061-1153 5061-1154 5061-1155	T T
<p>*These items included in 3456A Digital Voltmeter Service Kit for Component Level Repair (-hp- Part Number 03456-69800)</p> <p>**These items are not required if a board level repair strategy is to be used. This strategy does require a 3456A Digital Voltmeter Service Kit for Board Level Repair (-hp- Part Number 03456-69801).</p> <p style="text-align: center;">P = Performance Test T = Troubleshooting A = Adjustment O = Operators Check</p>			

SECTION II

INSTALLATION

2-1. INTRODUCTION.

2-2. This section of the manual contains the necessary information and instructions to install and interface the Model 3456A Digital Voltmeter. Included are initial inspection procedures, power and grounding requirements, environmental information, and instructions for repacking the instrument for shipment.

2-3. INITIAL INSPECTION.

2-4. This instrument was carefully inspected both mechanically and electrically before shipment. It should be free of marks or scratches and in perfect electrical order upon receipt. The instrument should be inspected for any damage that may have occurred in transit. If the shipping container or cushioning material is damaged, it should be kept until the contents of the shipment have been checked for completeness and the instrument has been mechanically and electrically checked. Procedures for checking the electrical performance of the 3456A are given in Section IV. If there is mechanical damage, or the contents are incomplete, or the instrument does not pass the performance tests, notify the nearest Hewlett-Packard Office (a list of the -hp- Sales and Service Offices is located at the back of the manual). If the shipping container is damaged, or the cushioning material shows signs of stress, notify the carrier as well as the Hewlett-Packard Office. Save the shipping materials for the carrier's inspection.

2-5. PREPARATION FOR USE.

2-6. Power Requirements.

2-7. The Model 3456A requires a power source of 100, 120, 220, or 240 V ac (-10%, +5%), 48 Hz to 66 Hz single phase. Maximum power consumption is 80 VA.

2-8. Line Voltage Selection.

2-9. Figure 2-1 provides information for line voltage and fuse selection. Make sure the rear panel line selector switches are in the correct position and the correct fuse is installed in the 3456A, before applying ac power to the instrument.

2-10. Power Cords and Receptacles.

2-11. Figure 2-2 illustrates the different power plug configurations that are available to provide ac power to the 3456A. The -hp- part number shown directly below the individual power plug drawing is the part number

for the power cord set equipped with the appropriate mating plug for that receptacle. If the appropriate power cord is not included with the instrument, notify the nearest -hp- Sales and Service Office and a replacement cord will be provided.

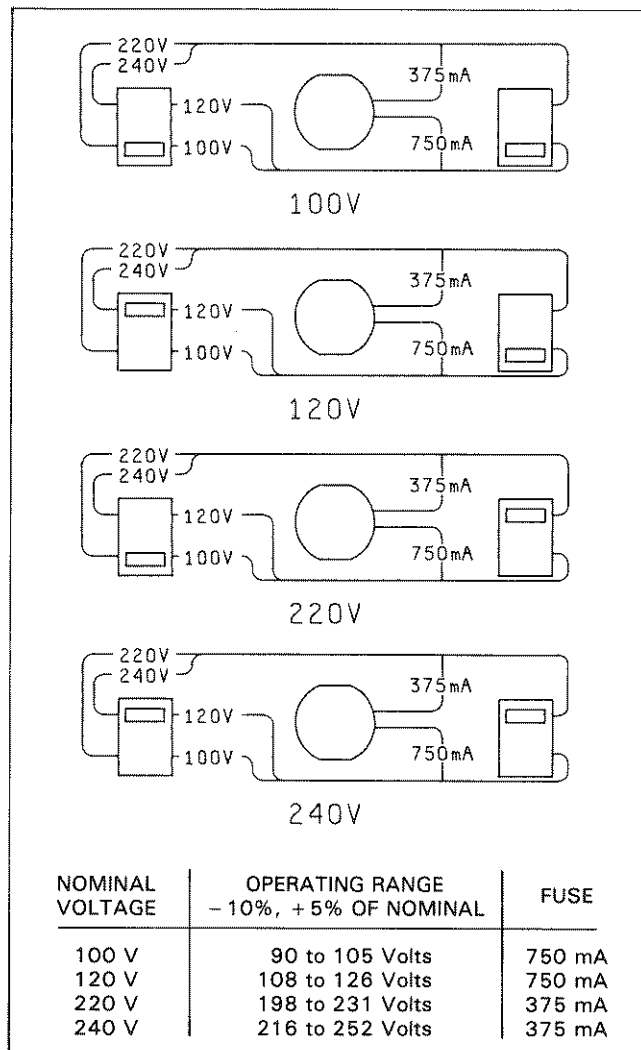

Figure 2-1. Line Voltage Selection.

2-12. Grounding Requirements.

2-13. To protect operating personnel, the National Electrical Manufacturer's Association (NEMA) recommendation is to ground the instrument panel and cabinet. The -hp- Model 3456A is equipped with a three conductor power cable which, when plugged into an appropriate receptacle, grounds the instrument.

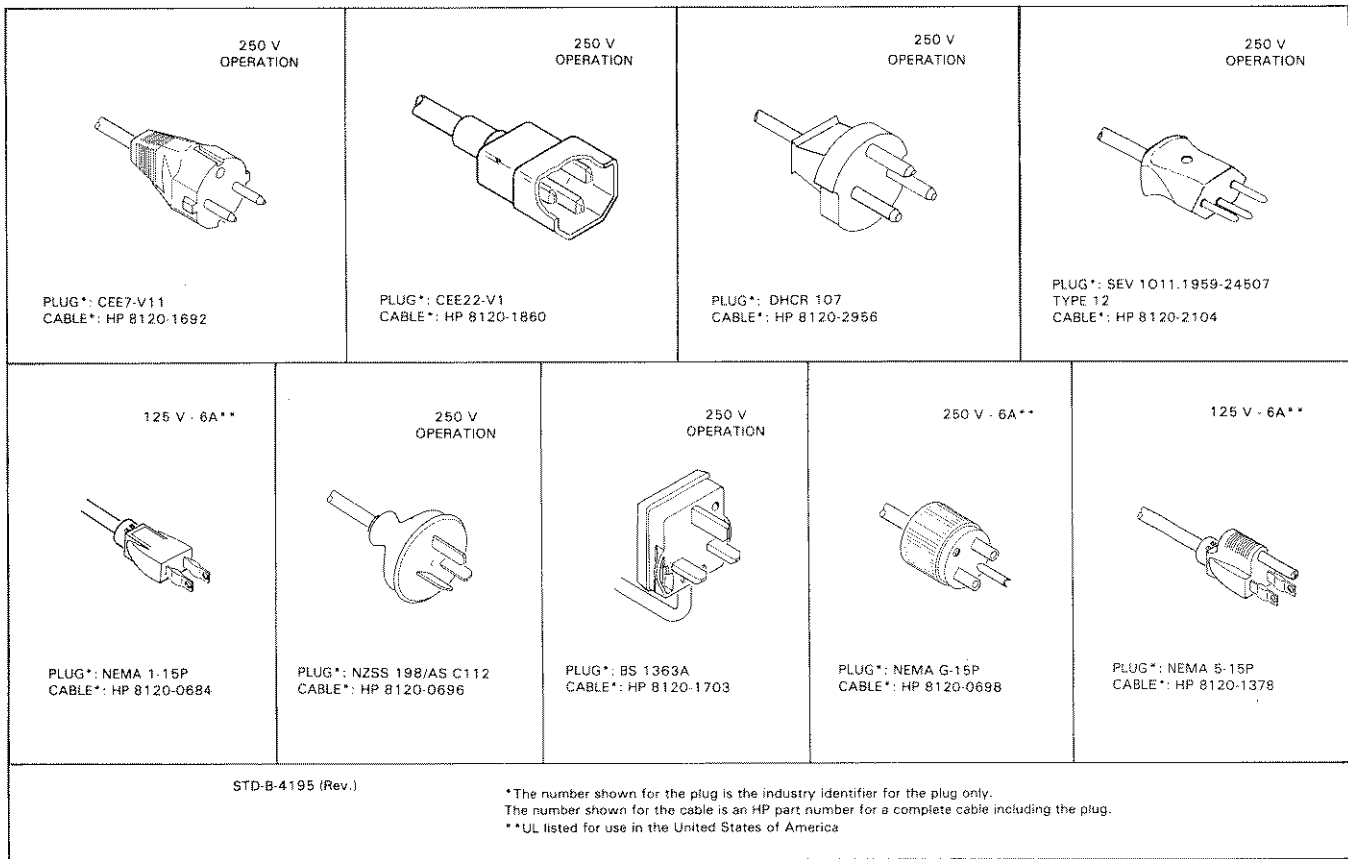

Figure 2-2. Power Cables.

2-14. Bench Use.

2-15. The Model 3456A is shipped with feet and tilt stands installed and is ready for use as a bench instrument. The feet are shaped to permit "stacking" with other full-module Hewlett-Packard instruments.

2-16. Rack Mounting.

2-17. The -hp- Model 3456A can be rack mounted by adding rack mounting kit Option 908 or Option 909. The basic hardware and instructions for rack mounting are contained in Option 908 and addition of front handles to the basic rack mount kit are contained in Option 909. The rack mount kits are designed to permit mounting of the 3456A in a standard 19 inch rack, provided that sufficient rear support is available. Also make sure the air intake at the rear of the instrument is unobstructed.

2-18. Interface Connections.

2-19. The -hp- Model 3456A is compatible with the Hewlett-Packard Interface Bus (HP-IB).

NOTE

HP-IB is Hewlett-Packard's implementation of IEEE Std. 488-1975, "Standard Digital Interface for Programmable Instrumentation."

The 3456A's HP-IB connection is made by an HP-IB Interface cable to the 24 pin HP-IB connector located at the rear panel. A typical interconnection of HP-IB is shown in Figure 2-3 in which system interconnection is made by three HP-IB Interface Cables. The ends of the cables have both a male and female connector to enable connections to other instruments and cables. As many as 15 instruments can be connected by the same interface bus. However, the maximum length of cable that can effectively be used to connect a group of instruments should not exceed 2 meters (6.5 feet) times the number of instruments to be connected, or 20 meters (65.6 feet), whichever is less. For a pictorial view of the HP-IB connector and its pin designation, refer to Figure 2-4.

2-20. Address Selection.

2-21. The HP-IB "talk" and "listen" address of the Model 3456A is set by the instrument's address switch, located at the rear panel. The talk and listen address is a 5-bit code which is selected to provide a unique address for each HP-IB instrument. The 3456A normally leaves the factory with the address switch set to decimal code "22." The corresponding ASCII code is a listen address code of "6" and a talk code of "V." Refer to Figure 2-5 for the factory address switch setting.

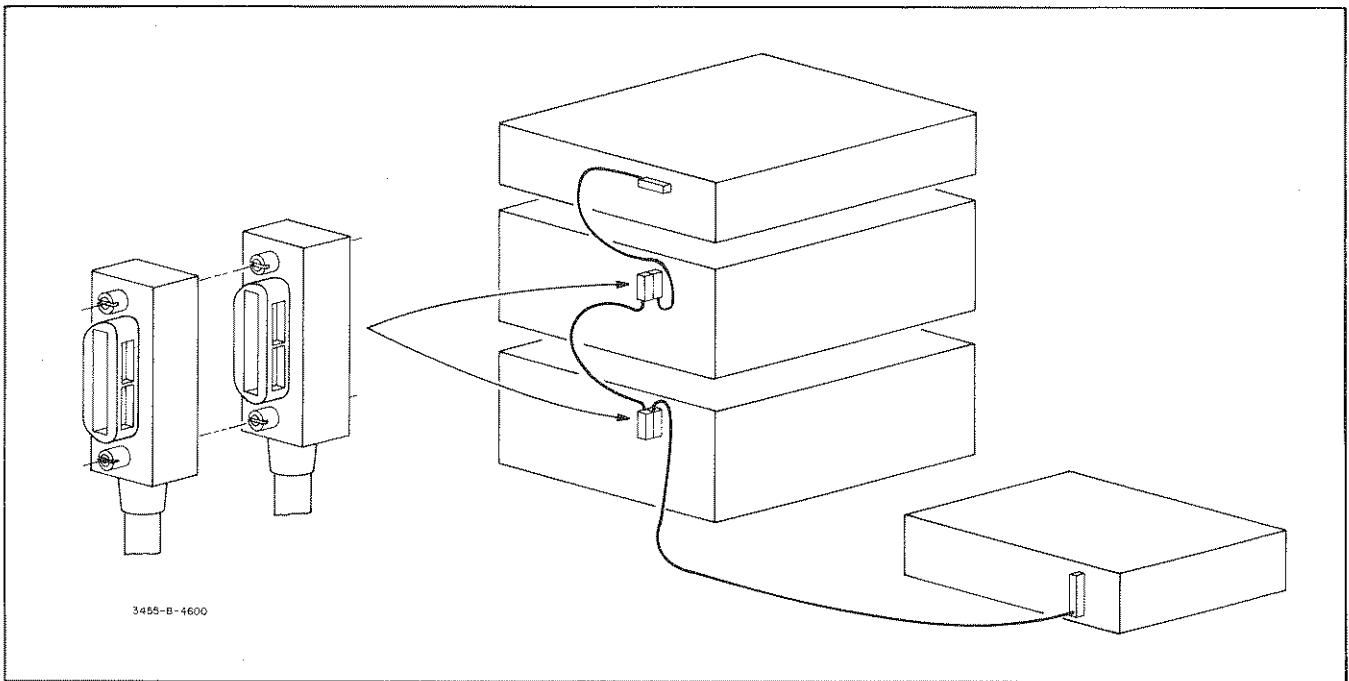

Figure 2-3. Typical HP-IB System Interconnections.

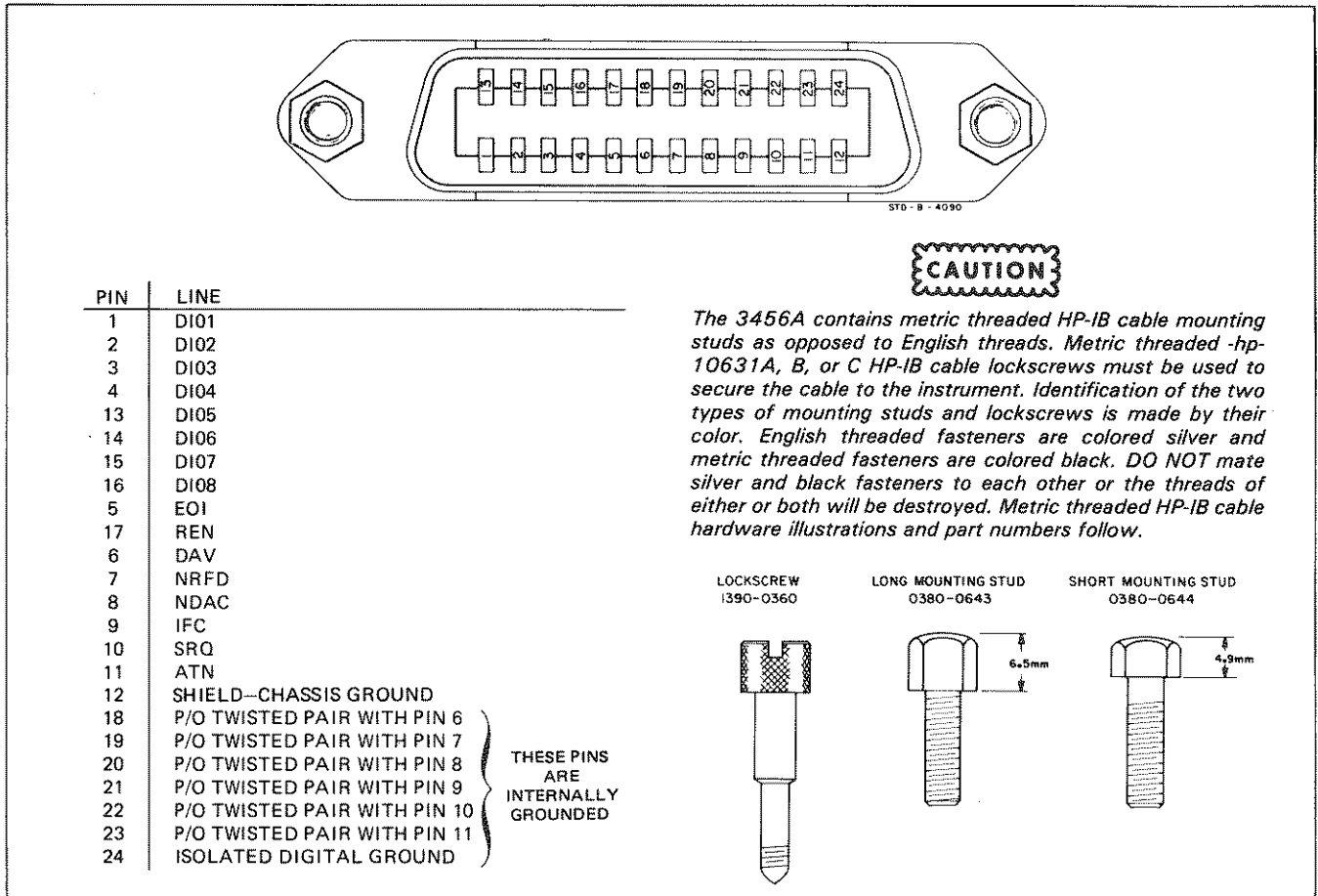

Figure 2-4. HP-IB Connector.

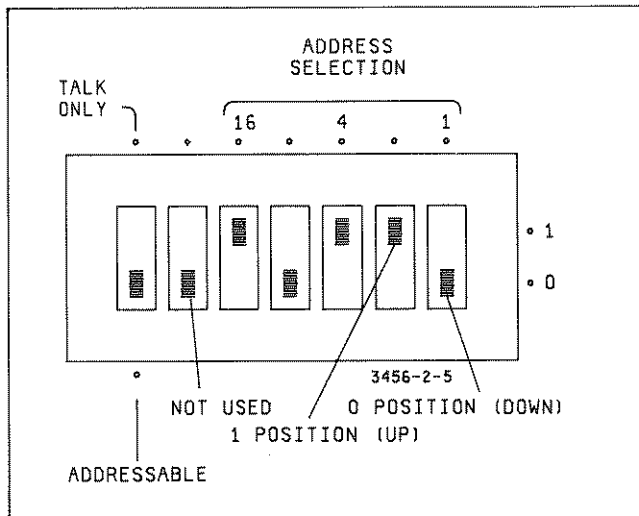

Figure 2-5. 3456A Address Switch.

NOTE

The 5-bit decimal code, consisting of bits A1 through A5, is often used by controllers which use this convention as a System Device Number for instruments.

2-22. "Talk-Only" mode. The instrument has a "Talk-Only" mode which can also be set by the address switch. The Remote Operation chapter in Section III of this manual gives a detailed description of the 3456A's "Talk-Only" mode, including the address codes.

2-23. External Trigger.

2-24. An External Trigger input to the 3456A is provided by a BNC connector located at the rear panel of the instrument. The trigger input should be driven by negative going TTL level signals. For more information refer to Section III in this manual.

2-25. Voltmeter Complete Connector.

2-26. A Voltmeter Complete output is also provided by the 3456A through a BNC connector located at the rear panel. This connector provides an output which is composed of a TTL level signal and is generated during a measurement cycle.

2-27. ENVIRONMENTAL REQUIREMENTS.

WARNING

To prevent electrical fire or shock hazards, do not expose the instrument to rain or excess moisture.

2-28. Operating and Storage Temperature.

2-29. In order to meet and maintain the specifications listed in Table 1-1, the 3456A should be operated within an ambient temperature range of $23^{\circ}\text{C} \pm 5^{\circ}\text{C}$ ($73^{\circ}\text{F} \pm 9^{\circ}\text{F}$). The instrument may be operated within an ambient temperature range of 0°C to 55°C ($+32^{\circ}\text{F}$ to 131°F) with less accuracy.

2-30. The 3456A may be stored or shipped within an ambient temperature range of -40°C to $+75^{\circ}\text{C}$ (-40°F to $+167^{\circ}\text{F}$).

2-31. Humidity.

2-32. The instrument may be operated in environments with relative humidity of up to 95%. The instrument must, however, be protected from temperature extremes which may cause condensation within the instrument.

2-33. Altitude.

2-34. The instrument may be operated at altitudes up to 4572 meters (15,000 feet).

2-35. REPACKAGING FOR SHIPMENT.

NOTE

If the instrument is to be shipped to Hewlett-Packard for service or repair, attach a tag to the instrument identifying the owner and indicating the service or repair to be made. Include the model number and full serial number of the instrument. In any correspondence, identify the instrument by model number and full serial number. If you have any questions, contact your nearest -hp- Sales and Service Office.

2-36. Place instrument in original container with appropriate packaging material and secure with strong tape or metal bands. If the original container is not available, a replacement container can be purchased from your nearest -hp- Sales and Service Office.

2-37. If the original container is not to be used, do the following:

1. Wrap the instrument in heavy plastic before placing in an inner container.
2. Place packing material around all sides of the instrument and protect the front panel with cardboard strips.
3. Place the instrument in the inner container in a heavy carton and seal with strong tape or metal bands.
4. Mark shipping container "DELICATE INSTRUMENT," "FRAGILE," etc.

SECTION III

OPERATION

3-1. INTRODUCTION.

3-2. This is the information and instructions for the operation of the -hp- Model 3456A Voltmeter showing front panel and remote operations. In addition, you will find functional checks you can perform. For more advanced users a Quick Reference Guide is shipped with the instrument. The information in the guide is most of the 3456A's operating characteristics, including remote programming codes.

3-3. Before reading the operating information in this section, familiarize yourself with the front and rear panel features as indicated in Figure 3-1. Use the figure as a reference by folding the page out while reading this section.

3-4. Read the front panel operations of the 3456A before the remote operations since most front panel operations also apply to the remote operations.

3-5. PRE-OPERATING INSTRUCTIONS.

3-6. The 3456A's operation can be separated into five main areas. A good understanding of these areas is fundamental to learning the operation of the instrument. The five areas are:

- a. Reset and Test Operation.
- b. Function, Range and Trigger.
- c. Voltmeter Control Functions, (Delay, Number of Readings/Trigger, Number of Digits Displayed).
- d. Math.
- e. Remote Operation.

3-7. Refer to Figure 3-1. Note that the 3456A's front panel can be separated into three areas: Display, Voltmeter Configuration, and Numbered Keyboard. Keep these areas in mind when you use the 3456A.

3-8. To learn the operation of the instrument, a logical approach is to ask yourself the following questions:

- a. "What type of measurement do I want to make?" - FUNCTION
- b. "Do I want autoranging?" - RANGE

- c. "Do I want the input filter in?" - FILTER
- d. "Is a math operation desired?" - MATH FUNCTION
- e. "Do I want remote control of the 3456A?" -REMOTE OPERATION

Once you have decided what you want the 3456A to do, the next step is to learn how to do it.

3-9. GENERAL OPERATING CHARACTERISTICS.

3-10. These paragraphs describe some of the 3456A's General Operating Characteristics. Refer to Figure 3-2, the Display Area, for the following discussion.

3-11. Turn-On and Warm-Up.

3-12. Before connecting ac power to the 3456A, make sure the rear panel line selector switches are set to correspond to the available power line voltage. Be certain the correct fuse is installed in the instrument. To meet accuracy specifications, the 3456A should be warmed up for at least one hour.

3-13. Reset.

3-14. After power connection and warm-up, to make sure the instrument is in the "turn-on" state, press the RESET button. This places the instrument in the power-up condition without cycling power. This provides you a convenient starting place and avoids thermal and electrical shock to the instrument, therefore maintaining its accuracy and improving reliability. The turn-on state is:

FUNCTION.....	DC
RANGE	AUTO
TRIGGER	INTERNAL
MATH	OFF
DELAY.....	DEFAULT (0 SEC.)
NUMBER OF READ- INGS/TRIGGER	1
NUMBER OF POWER LINE CYCLES INT.	10
NUMBER OF DIGITS DISPLAYED.....	5
AUTOZERO	ON
OPERATING MODE.....	LOCAL
FILTER	OFF
READING STORAGE	OFF

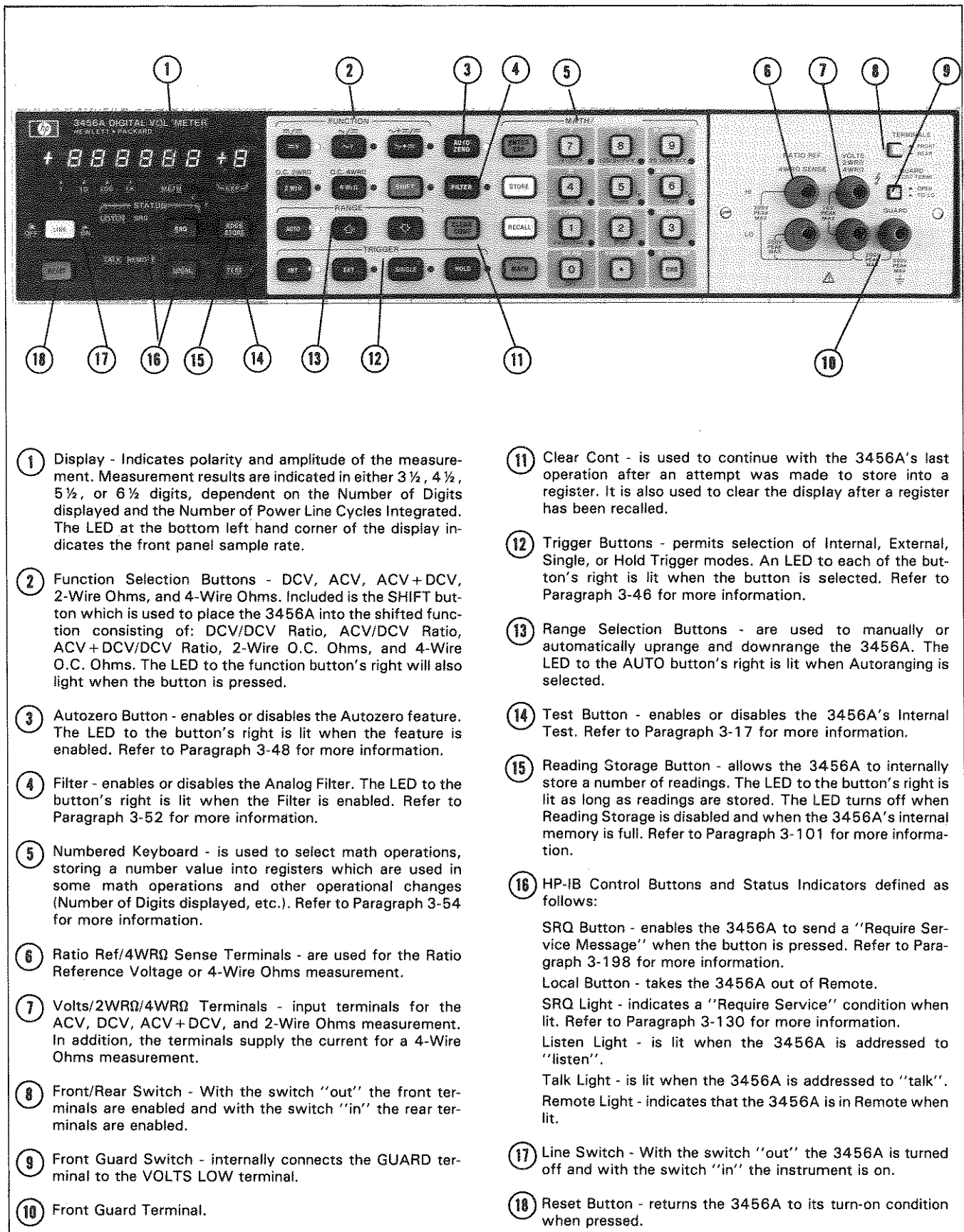

- ① Display - Indicates polarity and amplitude of the measurement. Measurement results are indicated in either 3 ½, 4 ½, 5 ½, or 6 ½ digits, dependent on the Number of Digits displayed and the Number of Power Line Cycles Integrated. The LED at the bottom left hand corner of the display indicates the front panel sample rate.
- ② Function Selection Buttons - DCV, ACV, ACV+DCV, 2-Wire Ohms, and 4-Wire Ohms. Included is the SHIFT button which is used to place the 3456A into the shifted function consisting of: DCV/DCV Ratio, ACV/DCV Ratio, ACV+DCV/DCV Ratio, 2-Wire O.C. Ohms, and 4-Wire O.C. Ohms. The LED to the function button's right will also light when the button is pressed.
- ③ Autozero Button - enables or disables the Autozero feature. The LED to the button's right is lit when the feature is enabled. Refer to Paragraph 3-48 for more information.
- ④ Filter - enables or disables the Analog Filter. The LED to the button's right is lit when the Filter is enabled. Refer to Paragraph 3-52 for more information.
- ⑤ Numbered Keyboard - is used to select math operations, storing a number value into registers which are used in some math operations and other operational changes (Number of Digits displayed, etc.). Refer to Paragraph 3-54 for more information.
- ⑥ Ratio Ref/4WRΩ Sense Terminals - are used for the Ratio Reference Voltage or 4-Wire Ohms measurement.
- ⑦ Volts/2WRΩ/4WRΩ Terminals - input terminals for the ACV, DCV, ACV+DCV, and 2-Wire Ohms measurement. In addition, the terminals supply the current for a 4-Wire Ohms measurement.
- ⑧ Front/Rear Switch - With the switch "out" the front terminals are enabled and with the switch "in" the rear terminals are enabled.
- ⑨ Front Guard Switch - internally connects the GUARD terminal to the VOLTS LOW terminal.
- ⑩ Front Guard Terminal.

- ⑪ Clear Cont - is used to continue with the 3456A's last operation after an attempt was made to store into a register. It is also used to clear the display after a register has been recalled.
- ⑫ Trigger Buttons - permits selection of Internal, External, Single, or Hold Trigger modes. An LED to each of the button's right is lit when the button is selected. Refer to Paragraph 3-46 for more information.
- ⑬ Range Selection Buttons - are used to manually or automatically uprange and downrange the 3456A. The LED to the AUTO button's right is lit when Autoranging is selected.
- ⑭ Test Button - enables or disables the 3456A's Internal Test. Refer to Paragraph 3-17 for more information.
- ⑮ Reading Storage Button - allows the 3456A to internally store a number of readings. The LED to the button's right is lit as long as readings are stored. The LED turns off when Reading Storage is disabled and when the 3456A's internal memory is full. Refer to Paragraph 3-101 for more information.
- ⑯ HP-IB Control Buttons and Status Indicators defined as follows:
 - SRQ Button - enables the 3456A to send a "Require Service Message" when the button is pressed. Refer to Paragraph 3-198 for more information.
 - Local Button - takes the 3456A out of Remote.
 - SRQ Light - indicates a "Require Service" condition when lit. Refer to Paragraph 3-130 for more information.
 - Listen Light - is lit when the 3456A is addressed to "listen".
 - Talk Light - is lit when the 3456A is addressed to "talk".
 - Remote Light - indicates that the 3456A is in Remote when lit.
- ⑰ Line Switch - With the switch "out" the 3456A is turned off and with the switch "in" the instrument is on.
- ⑱ Reset Button - returns the 3456A to its turn-on condition when pressed.

Figure 3-1. Front and Rear Panel Features.

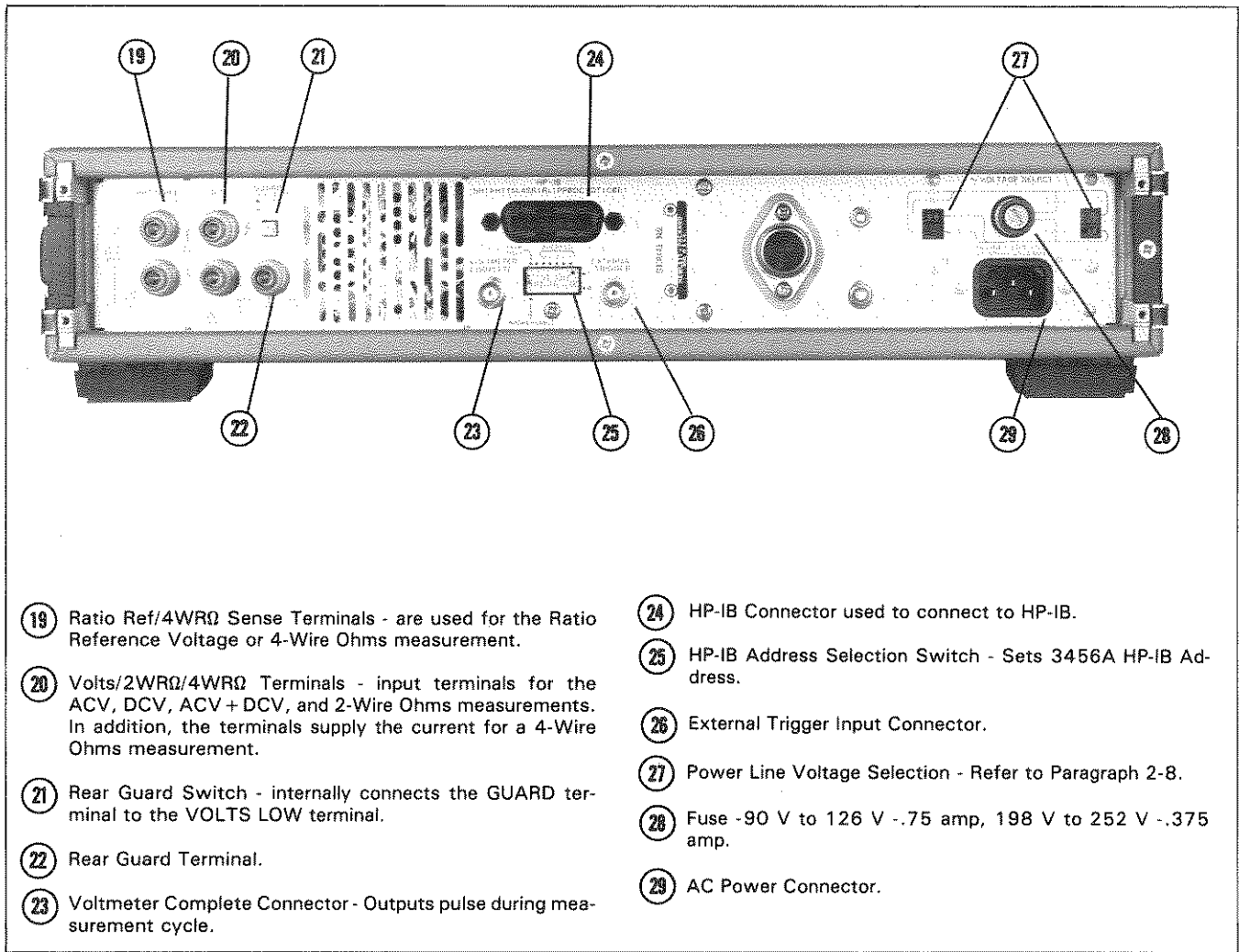

- 19 Ratio Ref/4WRΩ Sense Terminals - are used for the Ratio Reference Voltage or 4-Wire Ohms measurement.
- 20 Volts/2WRΩ/4WRΩ Terminals - input terminals for the ACV, DCV, ACV + DCV, and 2-Wire Ohms measurements. In addition, the terminals supply the current for a 4-Wire Ohms measurement.
- 21 Rear Guard Switch - internally connects the GUARD terminal to the VOLTS LOW terminal.
- 22 Rear Guard Terminal.
- 23 Voltmeter Complete Connector - Outputs pulse during measurement cycle.
- 24 HP-IB Connector used to connect to HP-IB.
- 25 HP-IB Address Selection Switch - Sets 3456A HP-IB Address.
- 26 External Trigger Input Connector.
- 27 Power Line Voltage Selection - Refer to Paragraph 2-8.
- 28 Fuse - 90 V to 126 V -.75 amp, 198 V to 252 V -.375 amp.
- 29 AC Power Connector.

Figure 3-1. Front and Rear Panel Features (Cont'd).

3-15. When pressing the RESET button, the display will momentarily display this for about 1 second:

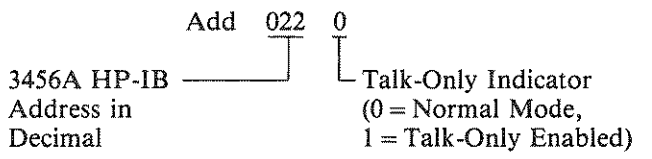

See Paragraph 3-150 for the HP-IB address setting and Paragraph 3-154 for the "Talk-Only" mode.

3-16. When power is cycled, "HP 3456" is momentarily displayed and then the address code is displayed.

3-17. Self Test Operation.

3-18. The 3456A's Test Operation consists of certain analog gain, offset, and digital checks when the TEST button is pressed. Make sure the 3456A's input terminals are completely floating and the GUARD switch is in the "IN" position, when selecting the test operation. The test may not pass if external connections are

made to the input terminals, because certain input circuitry measurements are made. When the TEST button is pressed, the instruments displays

"+ 1.8.8.8.8.8. + 8."

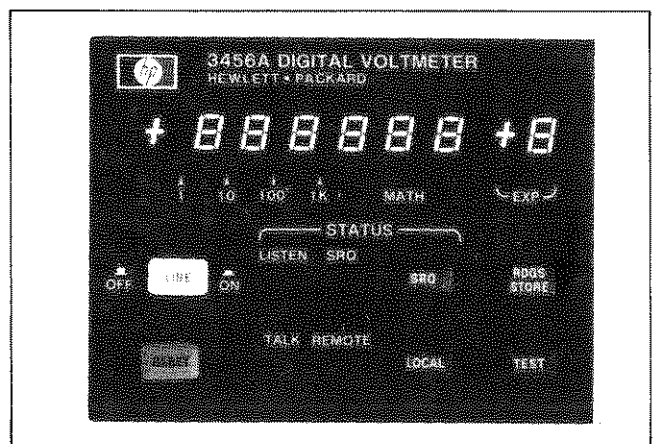

Figure 3-2. Front Panel Display Area.

and light all the front panel LEDs. This remains until the test is completed. Once the test is completed, the display and the LEDs go blank for a time and the test operation starts again. If any of the internal checks do not pass, a negative integer corresponding to the check which did not pass is displayed. The displayed number is also output over the HP-IB with the 3456A in remote. A '100' is output when the test passes. To disable the test operation press the TEST button a second time.

NOTE

Make sure no connection is made at the 3456A's Input Terminals and the GUARD switch is in the "IN" position during the Test mode.

NOTE

Refer the 3456A to a Service Trained Person, if the Internal Test does not pass.

3-19. Display.

3-20. Refer to Figure 3-3 to see how readings are displayed. Note that the 1 V through 1000 V ranges are displayed as they are measured with the decimal point in the correct place like this:

- 1.00000 – 1 V Range
- 10.0000 – 10 V Range
- 100.000 – 100 V Range
- 1000.00 – 1000 V Range

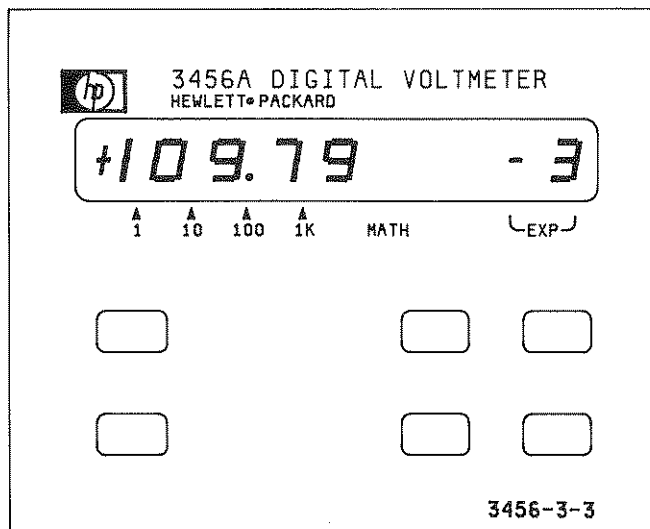

Figure 3-3. 3456A Display.

Additionally, a 1, 10, 100, and 1 K are marked on the front panel and are located below the decimal point of the respective ranges with the other ranges indicated in engineering notation. The position of the decimal point on the display marks the decade multiplier. The range is easily determined by multiplying the displayed exponent by the decade multiplier. For example:

decade multiplier → 1 0 9 . 7 9 -3
 → 1 10 100 1K EXP
 shows a reading of .10979 V or 109.79 mV. The decade multiplier is not used in the 3456A's Ratio and Math functions.

3-21. Error Messages.

3-22. Error Messages are displayed for invalid operating conditions. They are displayed like this:

E D

where "D" is the number indicating which error is generated. The instrument keeps displaying the Error Message until the condition producing the error is changed to a valid state. A listing of the various error messages is given in Table 3-1.

Table 3-1. Error Messages.

Error No.	Description
1	Autozero disabled in any Shifted Functions. Displayed in Remote only.
2	Analog Filter enabled in any Ohms Functions. Displayed in Remote only.
3	Any invalid Range and Function combination (Example: 10 M ohm Range selected for the DCV Function). Displayed in Remote only.
4	Attempt was made to store invalid number into a register (Example: a '9' is stored into the Number of Digits Displayed register).
5	Attempt was made to store any number into register C, M, or V.
6	Attempt was made to recall non-existent stored readings from memory.

3-23. OPERATING CHARACTERISTICS.

3-24. Refer to Figure 3-4, the front panel's Voltmeter Configuration area, for the following paragraphs.

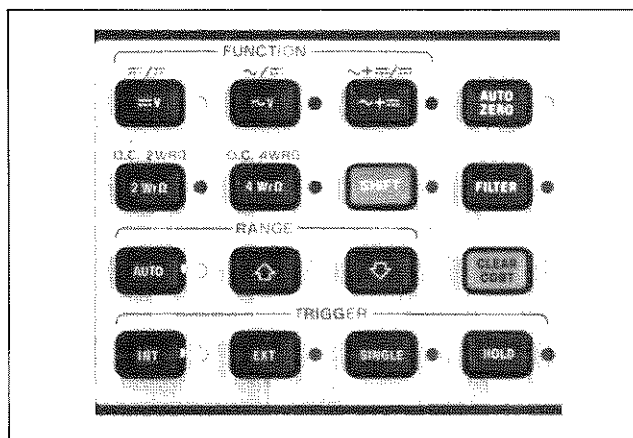

Figure 3-4. Front Panel Voltmeter Configuration Area.

3-25. DC Voltage Measurement.

3-26. The -hp- Model 3456A is capable of measuring dc voltages from 100 nanovolts through 1000 volts in five

ranges: 100 mV, 1 V, 10 V, 100 V, and 1000 V. All ranges are overload protected from input voltages up to 1000 V peak. The DCV input impedance is greater than 10^{10} ohms in the 100 mV to 10 V ranges and 10 M ohms in the 100 V and 1000 V ranges.

3-27. The measurement data can be displayed either as a $6\frac{1}{2}$, $5\frac{1}{2}$, $4\frac{1}{2}$, or a $3\frac{1}{2}$ digit reading, depending on the Number of Power Line Cycles Integrated (see Paragraph 3-61) and the Number of Digits selected (see Paragraph 3-63). Refer to Table 1-1 for accuracy specifications.

3-28. AC Voltage Measurement.

3-29. The -hp- Model 3456A uses a True RMS convertor and is able to measure voltages from $1\ \mu\text{V}$ to 700 V RMS in four ranges: 1 V, 10 V, 100 V and 1000 V. All ranges are protected from input voltages up to 1000 V peak or 700 V RMS, whichever is less. Measurement data can be displayed either as a $6\frac{1}{2}$, $5\frac{1}{2}$, $4\frac{1}{2}$, or a $3\frac{1}{2}$ digit reading, depending on the selected Number of Power Line Cycles Integrated (see Paragraph 3-61) and the Number of Digits selected (see Paragraph 3-63). The frequency response of the convertor is from 20 Hz to 250 kHz with a maximum input voltage of 1000 V peak (700 V RMS, 10^8 VHz). The input impedance of the convertor is 1 M ohms shunted by $< 75\ \text{pF}$. Refer to Table 1-1 for accuracy specifications.

3-30. AC+DC Measurement.

3-31. The AC+DC mode of the 3456A measures the combined ac and dc components of the input signal and displays its RMS value. Other operating characteristics are the same as the ACV function. Refer to Table 1-1 for accuracy specifications.

3-32. One use of the AC+DC function is to determine the necessary power rating of an amplifier. Since many

amplifiers have ac signals with dc components, the true RMS value of those complex waveforms may need to be known. The AC + DC feature of the 3456A can simplify these measurements since it can measure the RMS value of the sum of the ac plus the dc voltage on the waveform.

3-33. Resistance Measurement.

3-34. The Model 3456A is capable of measuring resistance from 100 micro-ohm to 1 giga-ohm in eight ranges. The ranges extend from the 100 ohm full scale to the 1000 Meg-ohm full scale range. Resistance Measurement can be made using either the 2-wire or the 4-wire configuration. Refer to Figure 3-5 for the correct ohms connection.

3-35. Resistance Measurements can be displayed as either a $6\frac{1}{2}$, $5\frac{1}{2}$, $4\frac{1}{2}$, or a $3\frac{1}{2}$ digit reading, depending on the Number of Power Line Cycles Integrated (see Paragraph 3-61) and the Number of Digits selected (see Paragraph 3-63). The 4-WIRE ohm sense terminals are protected to a maximum level of 350 V peak. Refer to Table 1-1 for accuracy specifications.

3-36. The 3456A displays negative (minus) resistance under two conditions:

- a. The inputs to the 4 WIRE SENSE (RATIO REF) or the 2WR Ω /4WR Ω (VOLTS) terminals are reversed from each other in 4-wire ohms function.
- b. Small negative voltages on measuring circuitry.

NOTE

With the measuring leads shorting or when measuring small resistances, negative readings may be displayed due to offsets in the ohms circuitry.

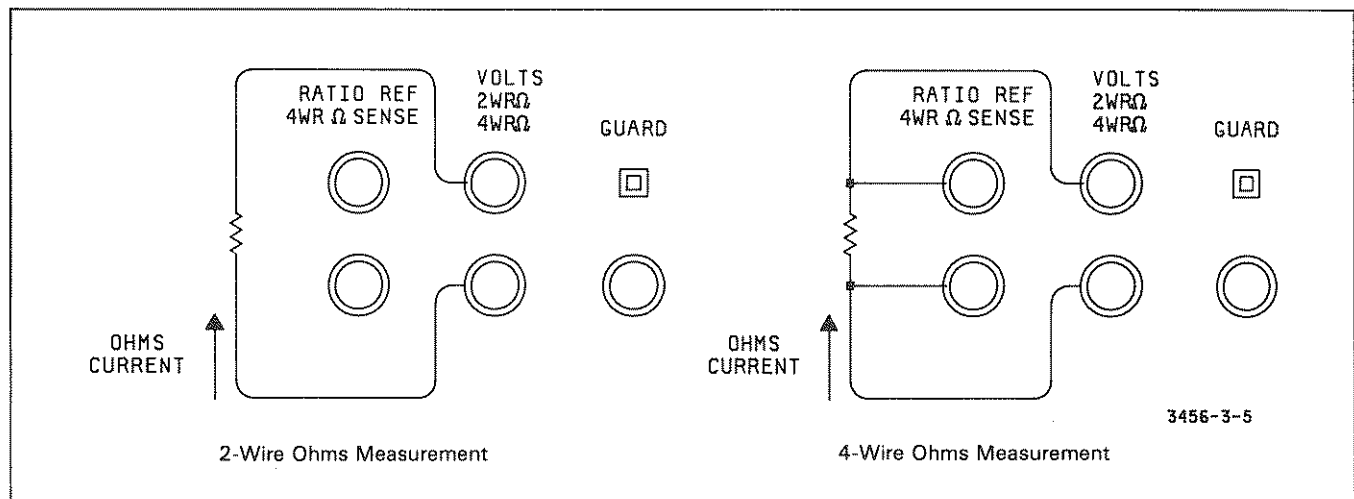

Figure 3-5. Ohms Connection.

NOTE

The 3456A's Analog Filter (see Paragraph 3-52) should not be used with any ohms functions. The filter is disabled when the ohms functions are selected from the front panel.

3-37. Shift Operation.

3-38. The purpose of the SHIFT button is to place the 3456A in the Shifted Functions. To disable the shifted functions, press the SHIFT button again. The SHIFT button's color is green and corresponds to the green lettering and symbols above the function buttons to identify shifted functions. All shifted functions readings are made by taking multiple measurements.

NOTE

The 3456A's Autozero feature (see Paragraph 3-48) is automatically enabled in front panel selectable shifted functions.

3-39. Ratio.

3-40. The -hp- Model 3456A can either make DCV/DCV, ACV/DCV, or ACV+DCV/DCV Ratio Measurements. This is done by taking a Signal, Reference High, and Reference Low Voltage reading which are all referenced to a common point, the VOLTS LOW terminal. The Signal Voltage is measured from the VOLTS HIGH terminal to the VOLTS LOW common. The Reference High Voltage is measured from the RATIO REF HIGH terminal to VOLTS LOW and the Reference Low Voltage is from the RATIO REF LOW terminal and VOLTS LOW. Refer to Figure 3-6 for a typical Ratio Measurement. Select the Ratio functions using the DCV, ACV, ACV+DCV function buttons in the shifted mode (press the SHIFT button). The green symbols above the function buttons identify the Ratio functions. Refer to Table 1-1 for accuracy specifications.

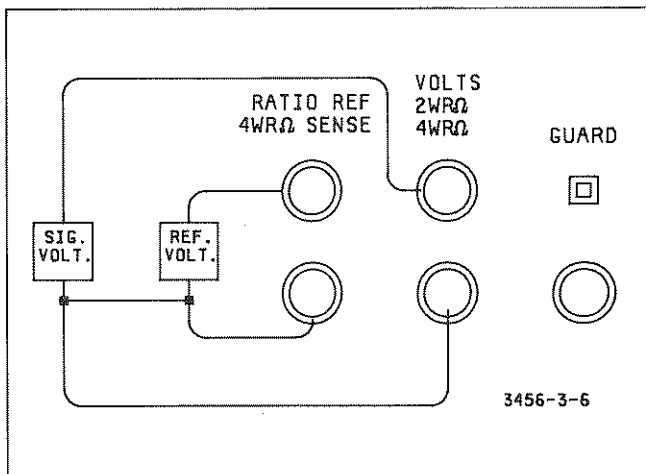

Figure 3-6. Ratio Connection.

a. Ratio Formula. A Ratio Measurement is a mathematical operation expressed in this formula:

$$\text{Ratio} = \frac{\text{Signal Voltage}}{\text{Reference Voltage}}$$

The 3456A Ratio Measurement formula is:

$$\text{Ratio} = \frac{\text{Signal Voltage}}{\text{Reference High} - \text{Reference Low}}$$

Remember, the three voltages are referenced to the VOLTS LOW terminal. The Reference Low voltage should be kept low for an accurate Ratio measurement (within $\pm 9\%$ of Reference High Voltage). The voltage can be kept low by shorting or otherwise connecting the RATIO REF LOW and VOLTS LOW terminals to each other, either at the terminals or measuring point.

NOTE

For a three wire Ratio Measurement connect the REFERENCE LOW and VOLTS LOW terminals to each other.

b. Ratio Measurement. For a Ratio Measurement the Reference Voltage can be between 0 to ± 12 V dc. The 12 V level is the maximum Reference Voltage level the instrument is able to measure (the RATIO REF terminals are protected up to 350 V peak). The Signal Voltage, which is applied at the VOLTS terminals, can either be dc, ac, or ac + dc volts from 0 to 1000 V peak or 700 V RMS. In addition, the Analog Filter (see Paragraph 3-52) and Delay (see Paragraph 3-67) are not used for the Reference Measurement. These features can be selected for the Signal Voltage Measurement. The following is a typical Ratio Measurement procedure.

1. Measure your Signal and Reference Voltages and make sure they are within the range for a Ratio Measurement (refer to Table 1-1 for the limits). Use the instrument's unshifted functions for those measurements.
2. Connect the Reference Voltage between the HIGH and LOW REFERENCE terminals.
3. Connect the Signal Voltage between the HIGH and LOW VOLTS terminals and connect RATIO REF LOW to VOLTS LOW.
4. Set the 3456A to the desired range or to Autorange.
5. Place the instrument into the Ratio mode by pressing the appropriate button (DCV/DCV, ACV/DCV, or ACV+DCV/DCV in the shifted mode).
6. Read the Ratio reading on the display.

NOTE

*It is important to remember that the **RATIO REF LOW** and **VOLTS LOW** terminals cannot be more than ± 12 V from each other.*

c. Typical Ratio Measurement. Matching resistor values for an accurate voltage divider is one way to use the 3456A's Ratio feature. Try this by using the set up in Figure 3-7. Connect the instrument as indicated in the figure. Make sure that REFERENCE LOW is connected at the top of R2 and that Signal (Volts) Common is connected at the bottom of R1. Once the instrument is connected and placed in the DCV/DCV Ratio mode, a Ratio Measurement is made. The voltage drop across R1 and R2 is measured including any offset voltages between Signal Common and Reference Low. The offset voltage is used to compensate for any error causing voltages between the input and resistors. Once all the measurements are taken, the Ratio Measurement is displayed on the front panel. If the resistors are equal in value, the reading should be approximately "– 1.00000".

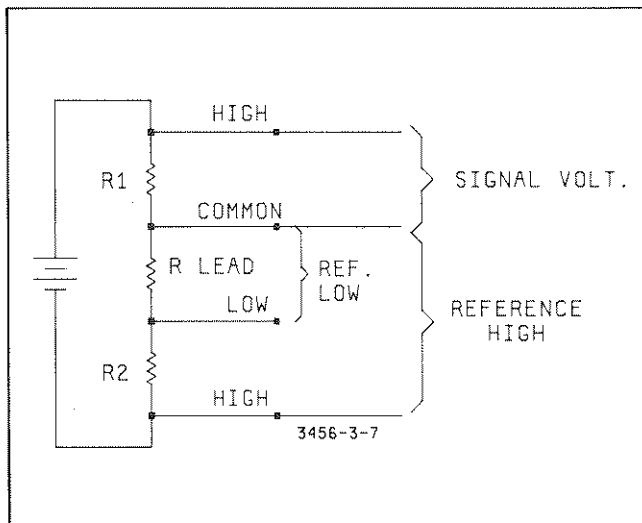

Figure 3-7. Typical Ratio Measurement.

3-41. Offset Compensated Ohms Measurement (O.C. Ohms).

3-42. This feature of the -hp- Model 3456A lets you take resistance measurements of components in the presence of small dc voltages. If this shifted function is selected, the instrument takes an ohms measurement and stores the reading into its internal memory. The ohms current source is then turned off and a dc reading is taken. This reading is subtracted from the previous reading and the resultant ohms reading is displayed on the front panel. Any small offset voltage on the measured component is compensated by the O.C. Ohms measurement. The maximum voltage level depends on the range selected (.01 V dc for the 100 ohm range, etc.). The O.C. Ohms ranges are from 100 ohm to 100 K ohm. Refer to Table 1-1 for the accuracy specifications.

NOTE

Due to internal switching in the 3456A, high capacitance(s) in parallel with the device or component being measured in the O.C. Ohms mode may cause erroneous readings.

3-43. You can use the O.C. Ohms feature of the 3456A to measure the contact resistance of a relay. Since some relay contacts may generate a small dc voltage (due to thermocouple effects), a normal ohms measurement technique may give incorrect readings. The O.C. Ohms feature subtracts this voltage from the ohms reading, and thereby gives an accurate resistance measurement of the relay.

3-44. Ranging.

3-45. The front panel range selection is controlled by three pushbuttons: the UPRANGE, DOWNRANGE, and AUTORANGE button. Their operation is as follows.

a. Uprange. The UPRANGE button's function is to set the 3456A to the next higher range, each time it is pressed. The highest selectable range depends on the function selected. For example, the 100 M ohm in the ohms function is not a valid range for the DCV or ACV functions and the 3456A defaults to the next highest valid range. The UPRANGE button is identified by an upward pointing arrow on its face.

b. Downrange. The function of the DOWNRANGE button is to set the 3456A to the next lower range, each time it is pressed. The lowest selectable range is the 100 mV or 100 ohms range. Similar to UPRANGE operation, the lowest range depends on the function. The ACV function, for example, has the 1 V range as the lowest range. If previously set to a lower range, the 3456A defaults to the 1 V range when the ACV function is selected. The DOWNRANGE button is identified by a downward pointing arrow on its face.

c. Autorange. With Autorange selected, the 3456A automatically selects the present reading's optimum range. Upranging is done when the reading is at or above 120% full scale. The downrange point is at or below 11% full scale. Try the following.

1. Place the 3456A into the Autorange mode; use a variable power supply and apply 1.0 V dc to the input. The range selected by the instrument is the 1 V range.
2. Increase the input voltage to > 1.2 V; the 3456A should then uprange to the 10 V range.
3. Decrease the input voltage to < 1.1 V; the instrument should then downrange back to the 1 V range.

d. Fast Autorange Feature. Autoranging by the 3456A is done quickly in both the upranging and downranging operations.

1. Upranging. When a voltage applied to the 3456A's input is higher than the range used at that time, an overload condition is detected. The overload condition is detected before the input measurement is complete. Upranging is done until the overload condition disappears and the optimum range is reached. Since the total measurement is never completed until the optimum range is reached, upranging is fast.
2. Downranging. Downranging is also done quickly by using a different method. When a non-overload measurement is made, the 3456A takes a complete measurement. Once the measurement is completed, the instrument then calculates the optimum range from the reading. A maximum of three ranges can be skipped at one time, enabling the 3456A to downrange quickly.

3-46. Instrument Trigger Modes.

3-47. The -hp- Model 3456A has four trigger modes: Internal Trigger, External Trigger, Single Trigger, and Hold. A description of each mode is as follows.

a. Internal Trigger. This trigger is internally generated by the 3456A and is used to initiate a measurement cycle. The instrument is placed into the Internal Trigger mode by pressing the INT (Internal Trigger) pushbutton located on the front panel. This trigger is also automatically selected when the RESET button is pressed and at turn on.

b. External Trigger. In the External Trigger mode, the instrument can be triggered by an externally applied trigger pulse. The pulse is applied to the External Trigger Input connector located on the rear panel and should be at least 500 nsec wide. The External Trigger Input is TTL compatible with actual instrument triggering occurring on the falling (negative) edge. By application of the pulse, the 3456A triggers and initiates a measurement cycle. After this cycle is completed, the instrument can be triggered again for a new cycle. If any triggering is done during the measurement cycle, the trigger is ignored until the cycle is completed. To start a new measurement, the 3456A has to be triggered again.

c. Single Trigger. The Single Trigger operation is similar to the External Trigger operation with triggering being accomplished by the front panel's SINGLE trigger pushbutton. Depressing the button first places the 3456A into the Signal Trigger mode (if the 3456A is in another trigger mode) and then triggers the instrument. A measurement cycle is then initiated. If the pushbutton is pressed again during the cycle, a new measurement cycle is started. The 3456A can be triggered again by depressing the SINGLE trigger pushbutton.

d. Hold. The Hold operation prevents the 3456A from accepting locally generated trigger commands, although an HP-IB trigger is accepted. Refer to the Remote Operation paragraphs for additional information on the HP-IB trigger.

3-48. Autozero.

3-49. The Autozero feature of the -hp- Model 3456A is used to compensate offsets in the dc input amplifier circuit of the instrument. Its main purpose is to correct for any zero drift in circuitry which may cause errors. The method used is to short the amplifier's input to circuit ground and take its offset reading. The reading is then stored in the instrument's internal memory and is later used to correct the following input measurement(s). Once the offset reading is taken, the short is removed and a regular input measurement is taken. As long as the Autozero feature is enabled, the 3456A takes an Autozero measurement and an input measurement. When the feature is disabled, an Autozero measurement is taken and is immediately stored into memory. No new Autozero measurements are made for the successive readings; only an input measurement is made. The stored Autozero reading is subtracted from the input measurement to correct the reading. Since only the input measurement is made, the 3456A's reading rate increases. This also makes the instrument more suitable for making measurements on high impedance circuitry, since no input switching is done. The 3456A's long term stability is affected (see Table 1-1) with the disabled feature, unless the Autozero reading is updated. Updating is done when any change in instrument state occurs. The only exception is that no updating is done by triggering, Front Panel SRQ, and HP-IB Local commands. The Autozero feature is enabled when the 3456A is first turned on and when pressing the RESET button.

3-50. Autozero Effects on 4-Wire Ohms Measurement.

3-51. The Autozero measurement is normally made with the input amplifier shorted to circuit ground. In the 4-Wire Ohms mode, the input amplifier is shorted to the 4-WRΩ SENSE Low terminal for the Autozero Measurement. With Autozero "ON", the Autozero reading is updated for each measurement cycle. With Autozero "OFF", the reading is not updated and causes an ohms measurement error if the measuring lead's impedance changes. To prevent this error, a new Autozero reading should be taken by changing or updating instrument state with the new measuring lead configuration. A disabled Autozero is useful in ohms measurements for a faster reading rate and where the 3456A's input switching may have affected the measurement.

3-52. Analog Filter.

3-53. The 3456A's Analog Filter is a 3 pole active filter with greater than 60 dB attenuation at frequencies of 50

Hz and higher. The filter is normally applied between the instrument's input terminals and input amplifier. An exception is when the 3456A is in the ACV or ACV + DCV unshifted or shifted functions. The filter is then applied between the output of the ac convertor and the input amplifier. In these modes, select the filter for accurate measurements below 400 Hz. Refer to Table 1-1 for the ACV and ACV/DCV accuracy specifications with the filter in or out. The Analog Filter is enabled (or disabled) by pressing the FILTER button.

3-54. NUMBERED KEYBOARD OPERATIONS.

3-55. Refer to Figure 3-8 for the 3456A's Numbered Keyboard selectable operations.

3-56. Storing Into Registers.

3-57. The next paragraphs explain the Number of Power Line Cycles Integrated, Number of Readings per Trigger, Settling Delay, and a variety of math operations. Except for math, other operations are changed by storing numbers into appropriate registers. The math operations are selected by pressing the appropriate math key. Table 3-2 gives a short description of the registers and math operations.

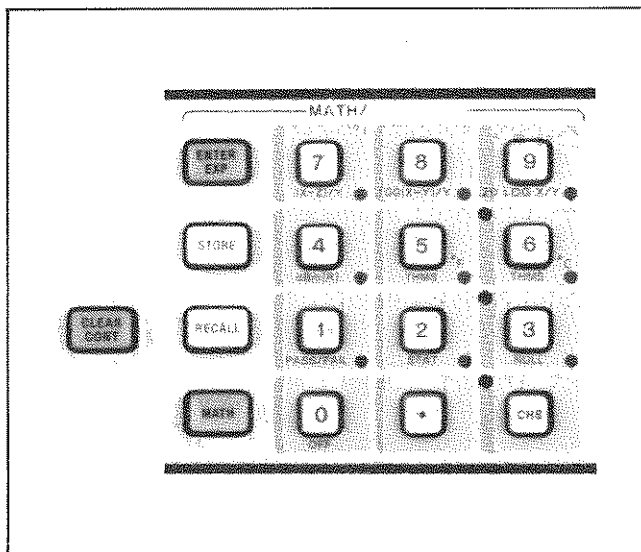

Figure 3-8. Front Panel Numbered Keyboard Area.

3-58. The Numbered Keyboard is very similar to those in pocket calculators with some keys performing more than two functions. Refer to the front panel. Note that the differences in key color, and the labeling above and below the keys determine the key's function. The blue color identifies the math operation, the white color identifies registers, and the black color identifies numbers, decimal point, and polarity. The white and blue color buttons located to the keyboard's left corresponds to the math and register operations.

3-59. Various LEDs on the keyboard annunciate which math function has been selected and which register contains a non-default number. For example, the LED next to the PASS/FAIL label lights if you select this math operation.

3-60. Storing numbers into registers:

a. Store. Numbers stored into registers changes the instrument's operation. For example, select the 100 Power Line Cycles Integrated mode (10 Line Cycles is the default value). To do this, "100" has to be stored into register N CYC INT. Try the following procedure.

1. Press the "1" key and the "0" key twice. These keys are on the Numbered Keyboard.
2. A "100" should now be displayed on the front panel.
3. Next press the white STORE button and then the CHS key (note, the white label above the CHS key is N CYC INT). The CHS key, which is normally the Change of Sign key, becomes the N CYC INT register key when the STORE button is pressed. (The CHS key is normally used to change the polarity of a number which is typed in from the keyboard, before storing into a register.)
4. The 3456A is now set to 100 Power Line Cycles Integrated. Use the same method to store numbers into the other registers.

Using this method you can select a six digit number (and a "1" as the overrange number) of any value and store it into a register. When a number is entered from the keyboard, the number is displayed before it is stored into a register. There is one important thing to remember when storing numbers. Some registers only accept certain numbers. The N DIG DISP (Number of Digits Displayed), for example, only accepts either a 3, 4, 5, or 6, since these are the only number of digits the 3456A can display. If you try to store an illegal number, Error 4 will be displayed.

NOTE

Since only a six digit number and overrange number can be entered, any additional numbers will be ignored.

b. EXP (Exponential). There are two ways to store numbers into registers using the Numbered Keyboard, Fixed Point and Floating Point. One way is to enter a number digit by digit and the other way is using the EXP (Exponential) key. A digit to digit entry looks like this: Enter "2", "0", "0", "0" to display "2000"

or

Enter ".", "0", "2" to display ".02"

To enter the same numbers using the EXP key, first enter all of the number's significant digits and then press the ENTER EXP button. Once this is done, the displayed number is then stored into the desired register. The exponent can also be changed from a "+" to a "-" by pressing the CHS key. This is done before or after you enter the exponent and after pressing the ENTER EXP key. To enter "2000", do this:

Enter "2", press ENTER EXP key, and enter "3" displaying "2 + 3". The same as "2000"

To enter the number ".02" do this:

Enter "2", press the ENTER EXP button, enter "2", and press the CHS key displaying "2 -2". The same as ".02"

Table 3-2. Registers and Math Listing.

Key	Register	Registers Default Values	Description
CHS	N CYC INT	10	Used for changing and determining the Number of Power Line Cycles Integrated
.	VARIANCE	-00.000-3	Used for storing the variance value determined from Statistics Math Operation
0	MEAN	199999+9	Used for storing the Mean Value determined from the Statistics Math operation.
1	LOWER	-1999999+9	Used for storing the lower value for the Pass/Fail Math operation or the lowest reading taken in the Statistics Math operation.
2	UPPER	1999999+9	Used for storing the upper value for the Pass/Fail Math operation or the highest reading taken in the Statistics Math operation.
3	DELAY SEC	0	Used for changing and determining the 3456A's Settling Delay.
4	R	600	Used for storing the resistor value for the dBm Math operation or for recalling readings taken in the 3456A's Reading Storage mode.
5	COUNT	0	Used for storing the number of readings taken while in the Statistics Math operation.
1	N RD/TRIG	1	Used for changing and determining the Number of Readings taken or are to be taken per Trigger.
7	Z	0	Used for storing a number value for the Scale Math operation and stores the first statistics Reading.
1	Y	1	Used for storing a number value for the Scale and %Error Math operation.
9	N DIG DISP	5	Used for changing and determining the 3456A's Number of Digits Displayed.
Math			
CHS	-		
.	-		
0	OFF		Disables Math operation.
1	PASS/FAIL		Used to determine if a reading(s) is within set limits.
2	STATS		Used to calculate the Mean, Variance, Upper, Lower, and Count of a reading(s).
3	NULL		Used for offset compensation of the following reading(s) taken.
4	DBM		dBm calculation.
5	THMS F		Used in calculating a Thermistor reading(s) in degrees Fahrenheit.
6	THMS C		Used in calculating a Thermistor reading in degrees Celsius.
7	(X-Y)/Y		Used for the Scale calculation.
8	100 (X-Y)/Y		Used for the %Error calculation.
9	20 LOG X/Y		Used for the dB calculation.

NOTE

Pressing the EXP key before entering a number will display 1 + 0.

c. Recall. Any of the Registers can be recalled at any time. By pressing the RECALL button and the key for the Register to be displayed. (Remember, the registers are in white.) The Register's value is then displayed on the front panel.

d. Clear-Continue. The CLEAR-CONTINUE button, when pressed, clears the display and continues with the previous operation. This can be useful when accidentally entering an incorrect number from the keyboard. The Clear-Continue feature clears the incorrect number and starts a new measurement cycle. This feature can also be used when a register is recalled and no changes in the register are desired.

3-61. Number of Power Line Cycles Integrated.

3-62. This feature of the -hp- Model 3456A allows you to select the integration time from .01 to 100 power line cycles in multiples of 10. Since a power line cycle of "1" has a time period of 1/60 second, 1/50 for the 50 Hz option, the intergration time is 1/60 or 1/50 second. The Number of Power Line Cycles Integrated determines measurement time. The slowest integration time of the 3456A is 100 Power Line Cycles Integrated and the fastest is .01 line cycles. For good power line frequency noise rejection (Normal Mode Rejection), use integration times of either 1, 10, or 100 power line cycles. Use the Store method in Paragraph 3-60 to select the various integration times (Number of Power Line Cycles). The default value of the Number of Power Line Cycles Integrated is 10 (at Turn-on and Reset).

3-63. Digits Displayed.

3-64. The 3456A can display either a 3, 4, 5, or 6 digit reading. Select any of these digits using the Store method in Paragraph 3-60. The Number of Power Line Cycles Integrated determines the maximum number of digits the 3456A can display. If the 1 to 100 Power Line Cycles Integrated are used, the 3456A can display from 3 to 6 digits. With .01 Integration Time the maximum number of digits then is 4 and with .1 Line Cycles Integrated the maximum is 5. Five is also the number of digits displayed at Turn-On or when the RESET button is pressed.

3-65. Number of Readings per Trigger.

3-66. The Model 3456A is capable of taking from 1 to 9999 Readings per Trigger. Selection of the Number of Readings per Trigger is accomplished by using the Store method in Paragraph 3-60. The selected number of readings are executed each time the instrument is triggered. Although the Internal, External, and Single Trigger modes will take the selected number of readings, it

may be advantageous to use the External or Single Trigger modes. Using these modes, if a Single Trigger is sent the 3456A starts taking the readings and stops when all the readings are taken. Another trigger repeats the same operation. An Internal Trigger also does the same thing, but automatically triggers again when all readings are taken. The default value of the Number of Readings per Trigger at Turn-On or at Reset is "1".

3-67. Settling Delay.

3-68. This feature of the -hp- Model 3456A can be used to delay the 3456A's input measurement for a preselected time, before a measurement cycle (A/D operation) is started. The amount of Settling Delay is selected by using the Store method in Paragraph 3-60. In some modes (ACV, OHMS, and Analog Filter), a delay value is selected by the instrument. These selected delays are defined in Table 3-3 and can be changed to another value by using the Store method. Any number value from .001 second to 999.999 seconds (including 0) can be chosen for a delay in any mode. To return a 3456A selected delay to its default value store any negative number into the DELAY register.

Table 3-3. Default Delays.

3456A Set-Up Condition	Delay (in second)
DCV, Filter On	.650
ACV or ACV + DCV, Filter Off	.060
ACV or ACV + DCV, Filter On	.800
Ohms, 100 K Range	.001
Ohms, 1 M Range	.008
Ohms, 10 M Range	.080
Ohms, 100 M Range	.080
Ohms, 1 G Range	.080

3-69. Optimizing the Reading Rate.

3-70. The previous paragraph stated that the Number of Power Line Cycles Integrated has an effect on the Number of Digits displayed. In addition to that, the measurement accuracy and power line frequency noise rejection (NMR) are also affected. You can select a faster reading rate with a low Number of Power Line Cycles Integrated. But keep in mind that the 3456A's measurement error increases and that the ability to reject power line frequency noise rejection is lessened. Table 3-4 gives some ideas on how to optimize the 3456A's reading rate.

3-71. MATH FEATURE.

3-72. A variety of math operations can be done by the Model 3456A. Use the instrument's Numbered Keyboard to select a math operation and to enter values into registers used by the math operations. Refer to the Numbered Keyboard for the following discussion and make sure you know how to store values into registers

Table 3-4. Optimizing Reading Rate.

OPTIMIZING YOUR READING RATE

Your maximum reading rate with the 3456A is influenced by a large number of factors, not the least of which is the signal you are trying to measure. These factors can be divided into two categories; signal related and voltmeter related. Among signal related factors are:

- desired accuracy (or resolution)
- nature of the signal (dcv, acv, or ohms)
- signal environment (line related and broadband noise)

Among voltmeter related factors are:

- method of measurement transfer (Packed Output, Reading Storage, System Output)
- number of convenience features selected (Math operations, Autorange)

For all operations, an equally important consideration is what you're trying to accomplish by measuring fast. Are you

- scanning a large number of points so that faster readings mean a better picture of what is happening at a single point in time?
- trying to read fast so that you do not use up valuable computer time waiting for the measurement operation to complete?
- trying to digitize waveforms?

The 3456A can solve these application problems in many different ways.

AT TURN-ON

For most bench and system applications, the preprogrammed settling times assure accurate readings regardless of the signal and signal environment. However, knowledge about your signal and/or signal environment can let you achieve up to 330 rds/s (at 60 Hz) with noise rejection and 10 microvolt sensitivity.

YOUR SIGNAL ENVIRONMENT

Your signal is subject to line related and broadband noise which can interfere with the measurement. There are two ways of rejecting noise on the 3456A; integration and input filtering.

Integration is a process where the affect of line related noise is averaged to zero over the period of an integer number of Power Line Cycles (PLC) during the A to D conversion. The basic integrator is an Op Amp with a (integrator) capacitor in its feedback loop. The signal is connected to the input of the Op Amp for a period of the line frequency. This configuration theoretically provides infinite noise rejection at integer multiples of the inverse of the integration period and single pole roll-off (20 dB of amplitude attenuation for every decade increase in frequency above the knee frequency) for broadband noise. Refer to the graph for more detail.

The input filter provides excellent noise rejection. The price you pay is an additional 650 ms settling time which allows the filter output to settle to a final value before the input is measured. The fastest possible reading rate measuring widely varying signals with line rejection is provided by 1 PLC integration time. But, if you are looking at a slowly varying signal or scanning similar signals, you can get faster readings by overriding the preprogrammed settling

time selecting 0.01 or 0.1 PLC integration time and the filter. The trade-off is less accuracy and resolution as well as more uncertainty about the filtered input.

SPEEDING THE MEASUREMENT CYCLE

The thermal stability of the measurement environment is important. By simply keeping the temperature of the 3456A at a fixed value, you can nearly double the reading rate by turning Auto Zero off. The 3456A is slightly less accurate but the faster reading rate may be worth it. In addition, any range, function, or filter change that takes place is automatically accompanied by an Auto Zero update which removes any accumulated offsets. Of course, if the measurement environment is quiet enough to omit NMR then only the accuracy and resolution of your desired measurement are the factors and you can achieve up to 210 or 330 rds/s with .1 and .01 PLC respectively (60 Hz).

Further, you can speed the measurement cycle by selecting a fixed range instead of using the Autorange function. Even at 1 PLC integration time there is a 10% reduction of the reading rate with Autorange on. Of course, if your signal is changing, Autorange is far faster than letting your software range the 3456A over the HP-IB.

AC Volts requires some special attention. With the filter off, you can measure signals of greater than 400 Hz frequency at a rate of 12 rds/s with the preprogrammed settling time of 60 ms. If you are monitoring a slowly changing ac signal or scanning similar signals, you can minimize the settling time to achieve up to 330 rds/s. Keep in mind that the input could change drastically before your readings would indicate a large change.

For signals of less than 400 Hz the input filter is connected in series with the ac converter to slow the signal response to the A to D converter. Again, you can override the preprogrammed settling time of 800 ms but beware! Large changes in the input signal level may let you read numerous wrong readings while the ac converter and the input filter are settling to a final value.

The 3456A can read resistance measurements as fast as dc volts up to the 10 K ohm range, but you can not use the input filter. Above the 10 K ohm range, additional settling time is required for stable resistance measurements. If all you want is an indication of the actual resistance above 10 K ohm, you can override the preprogrammed settling times. However, just considering the size of the resistance you are trying to measure and any associated stray capacitance in the measuring circuit, you may want to add settling time between reading for best accuracy.

Offset Compensated Ohms is very slow (10 rds/s) by comparison with a standard ohms measurement. But, for a single input reading, it is the fastest way to measure low value resistances accurately in the presence of thermally generated voltage offsets.

Before leaving the topic of Speeding the Measurement Cycle, it is important to ask why you would use 100 or 10 PLC integration times. The answer is increased accuracy and reduced internal noise. If you really need all the accuracy and repeatability you can get, the 100 PLC is the place you want to be.

SPEEDING THE READING TRANSFER

You might make many accuracy compromises to attain an acceptable reading rate and still not be able to read as fast

Table 3-4. Optimizing Reading Rate (Cont'd).

as you could. Why? Because you have not optimally handled the transfer of data over the bus from the 3456A to your computer.

Let's take a closer look at the reasons for fast reading rates:

- High speed scanning
- Data Throughput
- Waveform Characterization

HIGH SPEED SCANNING

Typical applications of high speed scanning include temperature and strain profiling where a large number of measurements must be taken very quickly to "freeze" the phenomenon at some point in time. For this type measurement, data transfer from the voltmeter to the computer is not really required to go fast. As long as the scanner data does not exceed 350 measurements, the built-in memory can store all the measurements for one scanned sequence and transfer the data at the end of acquisition. In conjunction with Reading Storage, three other 3456A features make high speed scanning particularly easy to do:

- Program Memory
- Voltmeter Complete
- External Trigger

Program Memory can be used to store a series of measurement sequences and operate on the acquired data. For example, in a high speed scanning situation you could acquire the measurements as fast as possible in the Reading Store mode. Flag the computer and then output the data, perhaps already scaled, in ASCII format. It is almost a 10 to 1 savings in time during acquisition and the results are just as easy to use as if you load, acquire, and transfer individual readings. Voltmeter Complete can be used to increment the scanner sequentially without software interaction between the voltmeter, the scanner, and the computer.

To close the loop, the scanner can output a signal to the 3456A's internal trigger. The result is that once the measurements are initiated by your computer there is no additional need for computer interaction until the measurement sequence is complete.

The fastest possible reading rate for any integration time is achieved when:

- Autorange, Auto Zero, Math, Display and Filter are off.
- Measurements are stored in the built-in memory using internal trigger and the packed format mode.

Since the packed mode and Display off are functions only available over the HP-IB, the maximum reading rate is achievable only with remote operation. If your trigger source is fast enough, external triggering is just as fast as internal triggering.

Transferring the measurements in packed format over the bus to a 9825A Calculator using a Fast Read/Write Buffer transfer reduces the maximum reading rate by 10% and you have to unpack the stored data. But, you can store many more measurements using the computer's memory.

DATA THROUGHPUT

The 3456A solves many of the data throughput problems because Reading Store and Program Memory remove the constant control necessity from the computer. The ability to flag the computer from the front panel of the 3456A,

store measurement sequences in its memory, and flag the computer when it is done, lets you use both the 3456A and the computer to their best advantage. To avoid overrunning the computer with data from the 3456A, you can select the Systems Output mode which updates the output only after handshake.

WAVEFORM CHARACTERIZATION

The 3456A can digitize sinewaves up to about 100 Hz with fairly good accuracy. All the high speed modes must be used to acquire at least two samples per cycle. The Delay generator gives you about 1% timing accuracy.

Waveform characterization should be performed with a System Voltmeter. These voltmeters use a sample and hold technique which allows the waveform to be "frozen" at a well-defined point in time. An integrating-type voltmeter, like the 3456A, will always average the waveform over its integration period giving less accurate results. System voltmeters also typically have higher speed, greater bandwidth, and much more precise delay generation.

To summarize, let's look at the fastest reading rate set up again. Note that all convenience and accuracy features are eliminated and that the data is stored internally in the packed mode. This may not be right for your use. You may want a final answer which the Math functions could provide without computer interaction.

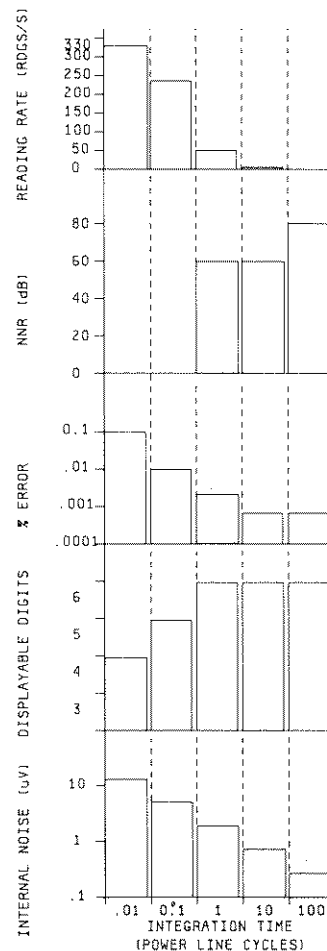

3456 TABLE 3-4

(read Paragraph 3-56). Figure 3-8, the Numbered Keyboard figure may also be helpful for the following discussion of the math operation. They are:

- %Error
- Scale
- Pass/Fail (Limit Test)
- dB
- dBm
- Null
- Thermistor
 - in Degrees C
 - in Degrees F
- Statistics
 - Mean
 - Variance
 - Count
 - Limits

3-73. Math operations can only be done on instrument acquired measurement data.

3-74. A Math operation is selected by first pressing the front panel's blue MATH button and then pressing the desired math key. The blue label below the front panel's numbered keys shows the various math operations. An LED, located to the center and below the display also lights when a math operation is selected. The registers used in the math operations are identified by the white labels above the numbered keys. The range of numbers you can store into the registers or use in math is from $\pm 0.000000 \times 10^{-9}$ to 1999999×10^9 . The 3456A does, however, do internal calculations using 9 digit floating point numbers. If any of the math calculations are out of range, an "LL" is displayed. The following describes the 3456A's math operations.

3-75. %Error.

3-76. The %Error math feature of the 3456A can best be described by the formula:

$$\text{Results in percent} = \frac{X - Y}{Y} \times 100$$

where "X" is the present measurement value and "Y" is the value in register Y. This formula gives the percent difference between the reading taken by the 3456A and the value in register Y. The default (Turn-On or Reset) value in register Y is 1. The %Error feature is selected by the "8" [100 (X - Y/Y)] key. Refer to Table 1-1 for the %Error accuracy specifications.

3-77. You can use the %Error function to determine the percent difference between an ideal voltage and a measured voltage. For example, you may wish to know the %Error of a 10 V dc measurement. The first thing to do is to store 10 into register Y. Then set the 3456A to the %Error math function and take a 10 V measurement. If the reading is exactly 10 V a "0" is displayed.

If the reading is, for example, 10.1 V, the result becomes:

$$\text{Result} = \frac{X - Y}{Y} \times 100 = \frac{10.1 - 10}{10} \times 100 = .01 \times 100 = 1$$

showing that the measured value is 1% higher than the ideal value. The number displayed on the front panel would be "1".

3-78. Scale.

3-79. The Scale feature of the -hp- Model 3456A lets you modify a measurement value by a selected value. The modification can be done either by addition, subtraction, multiplication, or division, depending on how the Scale function is used. The Scale mode is represented by the formula:

$$\text{Results} = \frac{X - Z}{Y}$$

where "X" is the present measurement value, "Y" is the value in register Y and "Z" is the value in register Z. The default (Turn-On/Reset) values in register Y and Z are 1 and 0, respectively. The Scale math feature is selected by the "7" [(X - Z)/Y] key. Refer to Table 1-1 for Scale accuracy specifications.

3-80. To do an addition or a subtraction, first enter a "1" into register Y. If you wish to perform an addition, enter a negative number into register Z. If a subtraction is desired, enter a positive number into register Z. The Scale formula then becomes:

$$\text{Results} = \frac{X - (\pm Z)}{1} = X - (\pm Z)$$

To perform a division, enter a "0" into register Z and the divisor value into register Y. The Scale formula then becomes:

$$\text{Results} = \frac{X - 0}{Y} = \frac{X}{Y}$$

Multiplication is performed by dividing the measured value by the inverse of the multiplier value (a fraction). Here again, a "0" is to be entered into register Z with the inverse value going into register Y.

3-81. Pass/Fail (Limit Test).

3-82. The Pass/Fail math operation can be used to make a voltage or ohms measurement and then determine if the reading falls within certain limits. The limits are selectable from the 3456A's front panel and should be stored into the instrument's UPPER and LOWER registers. Once the limits are stored and the Pass/Fail math operation is selected, the 3456A can then be set for a regular volts or ohms measurement. If the measured reading is within the selected limits, the reading will be

displayed. If the reading is above the upper limit, "HI" will be displayed. If the reading is below the lower limit, "LO" will be displayed. The default (Turn-On/Reset) values of the UPPER and LOWER registers are +1999999+9 and -1999999+9, respectively. The Pass/Fail feature is selected by the "1" (PASS/FAIL) key. Refer to Table 1-1 for the Pass/Fail accuracy specifications.

3-83. A way to use the Pass/Fail feature, is to make sure that a certain number of 1 K ohm resistors are within a 1% tolerance. To do this, you first should store the upper and lower accuracy limits into the 3456A's respective registers. In this case "1010" is stored into the UPPER register and a "990" is stored into the LOWER register. The next step is to select the ohms function and the 1 K ohms range. After you have done this, select the Pass/Fail math feature and start to measure the resistors one at a time. If the resistor value is within the 1% tolerance, in other words between 1.01 K ohms and .99 K ohms, the actual value of the resistor will be displayed on the front panel. "HI" will be displayed for any readings above 1.01 K ohms and "LO" will be displayed for any readings below .99 K ohms.

3-84. dB.

3-85. This feature of the 3456A is a Ratio Measurement of two voltages which is calculated and displayed in Decibels (dB). The dB formula is:

$$\text{dB} = 20 \text{ Log } \left| \frac{X}{Y} \right|$$

where "X" is the present measurement value and "Y" is the value in register Y. The default (Turn-On/Reset) value in register Y is 1. The dB feature is selected by the "9" (20 LOG X/Y) key. Refer to Table 1-1 for the dB accuracy specifications.

3-86. You can use the dB feature to measure the voltage gain of an amplifier. First measure the input voltage to the amplifier and store it into register Y. (You can store the reading directly into Y without re-entering the reading from the keyboard.) For this example a voltage reading of .1 V is assumed. The next step is to measure the amplifier's output voltage and set the 3456A to the dB math operation. The gain of the amplifier is then displayed in decibels. Assuming that the amplifier's output voltage is 10 V, the dB equation becomes:

$$\text{dB} = 20 \text{ Log } \frac{X}{Y} = 20 \text{ Log } \frac{10}{.1} = 20 \text{ Log } 100 = 40$$

giving you a gain of 40 decibels.

3-87. dBm.

3-88. The dBm feature of the 3456A is used to calculate a power ratio using a resistance as the reference. The

dBm equation is:

$$\text{dBm} = 10 \text{ Log } \left| \frac{X^2/R}{1 \text{ mW}} \right|$$

where "X" is the present measured value, "1 mW" is the power reference, and "R" is the resistance reference value to be entered by you. The default (Turn-On/Reset) value in register R is 600 ohms. The dBm math feature is selected by the "4" [dBm (R)] key. Refer to Table 1-1 for the dBm accuracy specifications.

3-89. The dBm feature can be used to measure the input power of a speaker. In this example we assume an 8 ohm speaker load and an input voltage of 10 volts. The formula now becomes:

$$\text{dBm} = 10 \text{ Log } \left| \frac{100/8}{.001} \right| = 40.97$$

giving you a value of 40.97 dBm.

3-90. Null.

3-91. The Null feature of the 3456A is described by the formula:

$$\text{Displayed Results} = X - X_1$$

where "X₁" is the first measurement taken after the Null feature has been selected and where "X" is the reading(s) after the first reading. When the "X₁" reading is first taken it is stored into register Z. That reading is then subtracted from the following reading(s) with the net present result displayed on the front panel. Since the first reading is stored in register Z, you can recall its value by recalling the register. The Null math feature is selected by the "3" (NULL) key.

3-92. The Null feature can be used to make more accurate 2-Wire Ohms measurements. To do this, short the input leads together at the measuring point and place the 3456A into the Null and 2-Wire Ohms mode. The first reading taken, which is the lead resistance, is stored into register Z. Remove the short from the input leads and take the unknown resistance measurement. The displayed reading is the total resistance measurement minus the lead resistance, giving you an accurate 2-Wire Ohms Measurement. The Null formula becomes.

$$\text{Unknown Resistance} = X - X_1 = X - R$$

where "X" is the total unknown resistance (including "R") and where "R" is the lead resistance.

3-93. Thermistor.

3-94. The 3456A makes temperature measurements using an externally connected thermistor, when selecting this mode. To correctly do this operation, set the 3456A

to the ohms function. It is advisable to first select an ohms range which corresponds closely to the resistance value of the thermistor for the temperature to be measured. When the Thermistor operation is selected, the ohms reading (thermistor resistance) is then calculated by the instrument and can be displayed either in degrees C or degrees F dependent on which math feature is selected. The Thermistor math operation with the results displayed in degrees C is selected by the "6" (°C) key. The "5" (°F) key is used for degrees F. Refer to Table 1-1 for the Thermistor accuracy specifications. The recommended Thermistor can be ordered by -hp Part Number 0837-0164. A package of 4 thermistors is also available under Accessory Number 44414A. The thermistor's corresponding resistor value at high and low temperature limits and at nominal room temperature is:

Temperature	Resistance
150°C	92.7 Ohms
25°C	5000 Ohms
-80°C	3684 K Ohms

3-95. Keep a couple of things in mind when using the Thermistor mode. Choosing an optimum ohms range for the temperature measurement has been mentioned in the preceding paragraph. This is important for a stable reading. You can use other ranges or autorange, but the reading may be unstable. To demonstrate this, choose a high ohms range for the thermistor. An ohms reading is still taken and the temperature is still calculated; but since a higher range is more sensitive for low ohms values, the reading is not as stable. Autorange may have the same effects, since there may be a difference from range to range. Another thing to keep in mind is lead resistance. If 2-Wire Ohms is used, any lead resistance is added to the thermistor resistance causing an inaccurate temperature reading.

3-96. Statistics.

3-97. The Statistics math feature of the -hp- Model 3456A is used to make a Mean and Variance calculation of reading(s) taken in any function. These calculations are made when the instrument is set to the Statistics (STAT) mode and after a measurement cycle is completed. The Mean value is then stored into the MEAN register with the number of readings taken stored into the COUNT register. The Variance value is stored into the VARIANCE register with highest reading taken stored into the UPPER register and the lowest reading into the LOWER register. In addition, the first reading taken is also stored into register Z. Except for the Variance calculation, all other statistics calculations are done after the first measurement cycle is completed. The Variance calculation needs at least two readings to calculate its value. The default values of the MEAN, VARIANCE, COUNT, UPPER, LOWER, and Z registers are 199999 +9, -00.000 -3 (0), 0, 1999999 +9, -1999999 +9, and 0 respectively. The Statistic

mode is selected by the "2" (STAT) key. To reset the registers to their default values without pressing the 3456A's RESET button or cycling power, select the statistics function again by pressing the MATH button and STAT key. Refer to Table 1-1 for the Statistics Accuracy Specifications.

NOTE

Since the math calculations are made to 9 digits, certain accuracy limitations as shown in Table 1-1 should be kept in mind.

3-98. **Mean.** The Mean (Average) value is calculated by the formula:

$$\text{Mean (M)} = X_1 + \frac{1}{C} \sum_{i=1}^C (X_i - X_1) = \bar{X}$$

Where "X_i" is the "ith" reading taken after enabling statistics, "X₁" is the first reading taken after enabling Statistics, and "C" is the total number of readings taken with the present reading (X) displayed on the front panel. The present Mean value is in the MEAN register and it, along with the other registers used in the Statistics mode, can be recalled at any time by recalling the appropriate register.

3-99. **Variance.** The Variance value is calculated by the formula:

Variance (V) =

$$\frac{\sum_{i=1}^C (X_i - X)^2 - \frac{1}{C} \left[\sum_{i=1}^C (X_i - X_1) \right]^2}{C - 1}$$

Where "X_i" is the "ith" reading taken after enabling statistics, "X₁" is the first reading taken after enabling Statistics and "C" is the total number of readings taken with the present reading (X) displayed on the front panel. The present Variance value is in the VARIANCE register and it, along with the value(s) in the other register(s), can be recalled at any time by recalling the appropriate register.

3-100. **Statistics Example.** One way to use the Statistics feature is to calculate the average value of a number of resistors. Start by setting the 3456A to the ohms function and Single Trigger mode. Then select the Statistics Math mode. Next connect the first resistor to the input terminals and trigger the instrument (push the SINGLE trigger button). Do the same for the other resistors after the measurement cycle is completed. When all of the resistors are measured, you can determine the average value of the resistors by recalling the MEAN register. The Variance of the register values can be recalled by the VARIANCE register. To doublecheck the number of resistors you have measured, recall the COUNT

register. For the lowest value, recall the LOWER register and the UPPER register for the highest value.

3-101. READING STORAGE.

3-102. The Reading Storage feature of the 3456A allows you to store into the instrument's internal memory a certain number of readings. The memory size is 1400 bytes and since each reading takes 4 bytes of memory up to 350 readings can be stored, depending on available memory space. This is because the Program Memory Operation of the 3456A (see Paragraph 3-200) also uses the internal memory and, if used, reduces memory space allowing fewer readings to be stored. The number of storable readings can be determined by this formula:

$$\text{Memory Size} - \text{Memory Used} = \text{Memory Available} \\ (\text{rounded off to the lowest value})$$

For example, if you use 85 bytes of memory for the Program Memory operation the total number of readings you can store is:

$$\frac{1400 - 85}{4} = 328.75$$

allowing you enough space for 328 readings.

3-103. The Reading Storage feature is enabled by pressing the front panel's RDGS STORE button. The LED next to the button then lights and the instrument starts storing a reading when triggered. The LED turns off when the feature is disabled or when the 3456A's internal memory is full. To turn the Reading Storage feature off, press the RDGS STORE button a second time. The readings in the memory are cleared when the Reading Storage is first turned on and the 3456A is triggered, by the Self Test mode, and at Turn-On.

3-104. Readings are stored into memory with the most recent reading as reading #1 and the preceding readings as #2, #3, and so on. For example if you take 350 readings, the reading taken after enabling the feature is #350 and the last reading taken is #1. The reading order is important to keep in mind when recalling the reading(s). Any or all of the readings can be recalled either one at a time or they can be scrolled. These two methods operate as follows.

a. Recalling Single Readings. To recall a single reading from memory

1. Set the 3456A to Trigger Hold and then turn Reading Storage on. The Trigger is set to Hold because a trigger restarts the Reading Storage, when enabled, and the previously stored readings are cleared.
2. Next store the number corresponding to the reading you wish to recall into register R (use store method in Paragraph 3-60).

3. Then recall the R register (by pressing the RECALL button and key "4").

The reading is then displayed on the front panel. When you press the RECALL button again without pressing the "4" key, the following reading is then displayed. Press the button again and the next reading is displayed, and so on. Try the following example in which reading #3 through #1 are recalled.

1. Press the HOLD trigger button and then press the RDGS STORE button.
2. Store "3" into register R by pressing the STORE button and then key 4.
3. Recall the register by pressing the RECALL button and key 4. Reading #3 is now displayed on the front panel.
4. Press the RECALL button again and reading #2 is displayed.
5. Reading #1 is next displayed when the RECALL button is again pressed.

b. Scroll Readings. This procedure is very similar in recalling a single reading. The only difference is that the reading number is entered into register R as a negative number. When that register is then recalled the reading which corresponds to the stored number is then displayed. The display time is determined by the DELAY register value. The next reading is then displayed and then the next reading and so on. Since the time between readings is very short and makes it impossible to see the readings, store a delay into the DELAY register. A 1 second delay, for example, will display each reading for 1 second. The last reading to be displayed is reading #1 and remains until the 3456A's operation is changed.

3-105. The 3456A can also perform other operations while recalling readings. When recalling a single reading, the reading number is displayed before displaying the actual reading. But since the display time is determined by the value in the DELAY register, the reading number may not be seen. Here again, a delay has to be stored into the DELAY register. The reading number is then displayed for a time determined by the delay. Another operation you can do is to select a math operation while the recalled readings are scrolled. For instance, select the Statistics math operation to find the Mean, Variance, Upper, Lower, and Count values of the stored readings. An example on how to use this feature with 350 stored readings is as follows.

- a. Press the HOLD trigger button and then the RDGS STORE button.
- b. Enter "-350" into the R register to scroll the readings starting with reading #350.

c. Select the Statistics math operation by pressing the MATH button and then the "2" (STAT) key.

d. Recall the R register by pressing the RECALL button and then the "4" (R register) key. The scrolled readings should now be displayed.

e. When the scrolling is completed (no updating of the display), the reading's Mean, Variance, and Count values can now be determined by recalling register MEAN, VARIANCE, and COUNT respectively.

3-106. VOLTMETER COMPLETE.

3-107. The voltmeter complete connector is a BNC connector which outputs a sync signal during the measurement cycle. The signal itself is composed of an approximately 330 nanosecond wide negative going TTL level pulse. One way to use the sync signal is to advance a scanner, like the -hp- Model 3497A. To do this, connect the 3456A's voltmeter complete output to the scanner's channel advance input. Once the connection is made, the scanner advances to the next channel during the 3456A's measurement cycle. The voltmeter complete output is designed to drive at least one TTL input.

3-108. GUARDING.

3-109. General.

3-110. The Guarding Terminals on the -hp- Model 3456A can be used to reduce or cancel error causing common-mode voltages. Figure 3-9 gives three methods of making guard connections. A Guard Terminal on the 3456A is used to make the connections. Both the front panel and the rear panel have a Guard Terminal. For most measurements the terminal should be connected to the common (Low) input terminal. This is done internally in the instrument when the Guard Switch is in the IN position. Each of the Guard Terminals use a separate switch for a connection to each of the common terminals, with the switches located above their respective Guard Terminals.

3-111. Guarding Information.

3-112. Detailed information on guarding methods and the purpose of guarding can be found in -hp- Application Note Number 123, "Floating Measurements and Guarding". This application note is available through your nearest -hp- Sales and Service Office.

3-113. FRONT/REAR SWITCH LOCKOUT.

3-114. The Model 3456A is provided with an interlock for the Front/Rear Switch. This has been provided for you to lock the switch either for the front or rear terminals, preventing any quick changes from front to rear. The switch is locked in the front position when the arrow marked on the lock is pointing toward the FRONT lettering. In the rear position the arrow is point

to the REAR lettering. A procedure to install and remove the lock is given in Appendix B.

3-115. REMOTE OPERATION.

3-116. General.

3-117. The following gives instrument dependent information necessary to remotely operate the -hp- Model 3456A over the Hewlett-Packard Interface Bus (HP-IB). Directions for mechanical interface connections to the HP-IB are given in Section II (see Paragraph 2-18) of this Manual. You should be familiar with the front panel (local) operation of the instrument before attempting to use the 3456A in the remote (HP-IB) operating mode. The front panel operational information is located in the Operating Characteristics paragraphs (starting with Paragraph 3-10) in this section of the Manual.

NOTE

HP-IB is Hewlett-Packard's implementation of IEEE Std. 488-1975, "Standard Digital Interface for Programmable Instrumentation".

3-118. HP-IB Description (in Appendix A).

3-119. A general description of the HP-IB is in this Manual's Appendix A. Refer to it for any non-3456A related HP-IB information. Included in the appendix is a worksheet you can use to tabulate the 3456A's HP-IB capabilities and of other Bus compatible devices. It is assumed, in the following paragraphs, that you are knowledgeable about the HP-IB.

3-120. 3456A Response to Bus Messages.

3-121. The following paragraphs deal with the implementation of the HP-IB using the 3456A. The instrument's Bus capabilities are listed in Table 3-5. The following also explains the 3456A's response to Bus Messages, also known as Meta Messages.

Table 3-5. Interface Functions.

Mnemonic	Interface Function Name
SH1	Source Handshake Capability
AH1	Acceptor Handshake Capability
T5	Talker (Basic Talker, Serial Poll, Talk Only Model, Unaddressed to Talk if Addressed to Listen)
L4	Listener (Basic Listener, Unaddressed to Listen if Addressed to Talk)
SR1	Service Request Capability
RL1	Remote/Local Capability
PPO	No Parallel Poll Capability
DC1	Device Clear Capability
DT1	Device Trigger Capability
CO	No Controller Capability
E1	Open Collector Bus Drivers

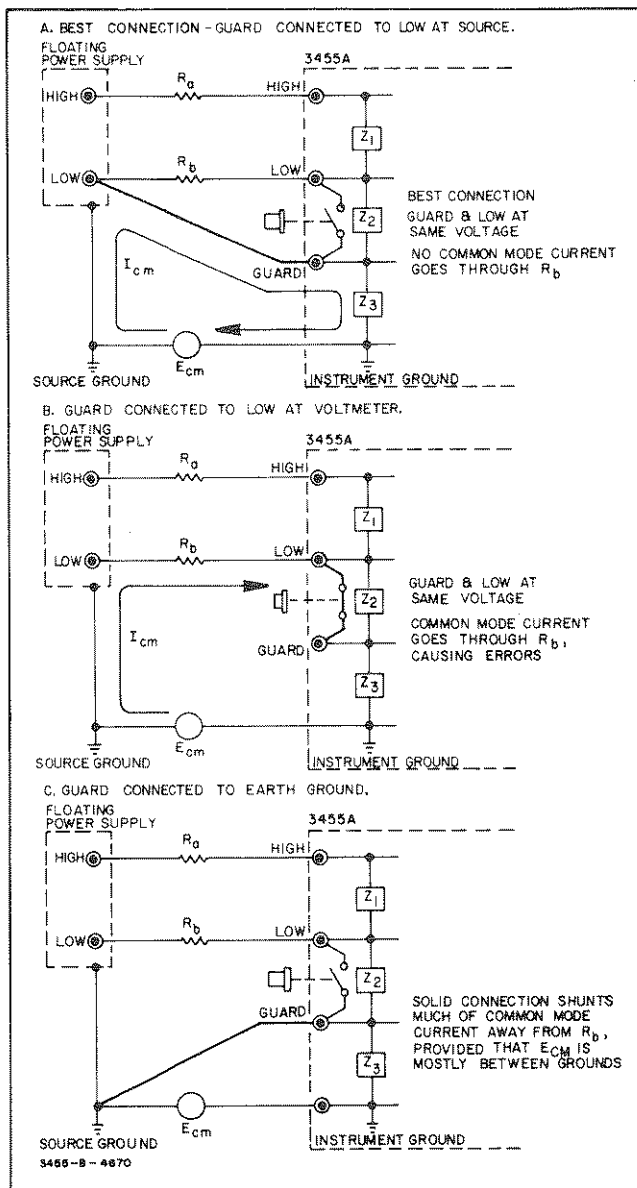

Figure 3-9. Guard Connection.

3-122. Data.

3-123. The Data Message is used to transfer information between the 3456A and the controller. It is used either to send data or receive data. A description is as follows.

a. Send Data is the 3456A's set up information (set to DCV, etc.). The instrument has to be in Remote and Listen (a listener) and the controller a Talker.

b. Receive Data is the 3456A's output. This includes readings and instrument status. To send the data, the 3456A is the talker and the controller is a listener.

3-124. Trigger.

3-125. The Trigger Message causes the 3456A to initiate

a measurement cycle. It is an HP-IB Trigger and triggers the instrument in any front panel Trigger mode, since it has priority over other trigger conditions. If the 3456A is triggered during a measurement cycle, the cycle is aborted. If the instrument is executing a measurement cycle, it will be aborted upon receipt of a Bus Trigger. The 3456A has to be programmed to "listen" to execute the trigger.

3-126. Clear.

3-127. The Clear Message sets the 3456A to the turn-on state. This action is similar to pressing the RESET button on the instrument's front panel. The Clear, Turn-On, and Reset differences are listed in Table 3-6.

Table 3-6. 3456A Clear, Home, and Reset Differences.

	Status Byte Byte Reset	HP-IB Address Reset	Hardware Reset	Program Memory and Reading Storage Clear	Time
Power-On	Y	Y	Y	Y	= 3 sec
Reset	Y	Y	N	N	< .5 sec
Clear	Y	N	N	N	< 5 msec
Home	Y	N	N	N	< 5 msec

Note: Y = YES, N = NO

3-128. Remote.

3-129. The 3456A is in the local front panel mode when first turned on. A Remote Message allow the 3456A to be controlled over the HP-IB. In Remote, the front panel controls are disabled (except the LOCAL button) and are then controllable over the HP-IB. The instrument's initial set up is determined by the front panel setting before being placed in remote.

3-130. Local.

3-131. This message clears the remote operation of the 3456A and enables the front panel operation. Pressing the front panel LOCAL button also sets the instrument to local, provided the button has not been disabled by the Local Lockout Message (see next paragraph).

3-132. Local Lockout.

3-133. This message disables the 3456A's Local Front Panel controls, including the LOCAL button. The message is in effect until the message is cleared over the HP-IB or power is cycled.

3-134. Clear Lockout and Set Local.

3-135. This message places the 3456A to local and clears the Lockout.

3-136. Require Service (SRQ).

3-137. The Require Service Message (SRQ) is indepen-

dent of all other HP-IB activity and is sent on a single line called the SRQ line. Its state is either true or false, with low being true and high being false. When the Require Service Message is sent and more than one device on the HP-IB has the capability to send this message, the user must decide which device is sending the message. This is done by conducting a "Serial Poll" for the device(s) on the Bus. The device polled responds by sending a Status Byte. The Status Byte indicates whether the device has requested service and if so, for what reason. If the device polled shows that it did not send the Require Service Message, the other devices would typically be polled. Paragraph 3-140 describes the 3456A's Status Byte.

3-138. When the 3456A sends a Require Service Message, the front panel SRQ LED is on. The message and LED are cleared when the 3456A is polled, although some of the messages are cleared by the instrument (i.e. Front Panel SRQ, Program Memory Complete, and Data Ready). The following are the conditions that can cause a Require Service Message.

- Front Panel SRQ (can be cleared by the 3456A)
- Program Memory Execution Complete (can be cleared by the 3456A)
- Data Ready (can be cleared by the 3456A)
- Trigger Too Fast
- Illegal Instrument State/Internal Error/Syntax Error
- Program Memory Error
- Limits Failure

3-139. The 3456A requires service only if told to do so. It has to be programmed to output the Require Service Message for the previously listed conditions. This is done by setting the Service Request Mask. The mask is set by sending certain program codes to the 3456A and is explained in Paragraph 3-169.

3-140. Status Byte.

3-141. The Status Byte Message is output by the 3456A in response to a Serial Poll. Each bit represents a message. Table 3-7 lists the bits which are defined as follows.

NOTE

Remember to set the SRQ mask to output the Require Service Message.

a. Front Panel SRO. A Require Service Message can be output when pressing the 3456A's front panel SRQ button. The button is only enabled in Local operation.

b. Program Memory Execution Complete. A Require Message is output when the 3456A's internally programmed operation, called Program Memory, is completed. Information on the Program Memory Operation is in Paragraph 3-200.

Table 3-7. Status Byte Definition.

Octal Code	Decimal Code	Bit	Definition
101	65	0	Front Panel SRQ - When the front panel SRQ button is pressed, this Require Service is output. Pressing the button a second time will clear the Service Request.
102	66	1	Program Memory Execution Complete -Indicates to the controller that all the program codes in the 3456A's internal memory are executed. The Require Service condition is cleared when the Program Memory is executed again.
104	68	2	Data Ready - Indicates to the controller that measurement data is ready to be output. The Require Service is cleared when a new measurement cycle is initiated.
110	72	3	Trigger Too Fast - Indicates that the 3456A was triggered while executing a measurement cycle. This only occurs in External Trigger.
120	80	4	Illegal Instrument State - Indicates that the 3456A is unable to do an operation because of an invalid set-up (e.g. 10 M ohm range in DCV) Internal Error - Indicates a failure in the 3456A Syntax Error - Indicates to the controller that invalid Program Code(s) where sent to the 3456A (e.g. code F9)
140	96	5	Program Memory Error - Indicates that the Program Memory Execution command or the Test function was stored in memory, or an overflow of memory occurred while loading into memory.
300	192	7	Limits Failure - Indicates that the Pass/Fail measurement made is out of the selected limits.

Note: Bit 6 is not in this table, because it is the SRQ bit.

c. Data Ready. A Require Service Message is output when the 3456A's measurement cycle is completed (e.g. a DCV reading is taken). More information on Data Ready is in Paragraph 3-206.

d. Trigger Too Fast. This Require Service Message is output if the 3456A is triggered while outputting data over the HP-IB. This can only be caused by the External Trigger.

e. Illegal Instrument State/Internal Error/Syntax Error. This Message is output for the following conditions:

1. Illegal Instrument State. An Illegal Instrument State is when the 3456A is, for example, unable to complete internal operations. An example is programming the instrument to the 10 M ohm range while in the DCV function. This range is invalid in the DCV function.

2. Internal Error. An Internal Error occurs is when a digital failure occurs in the 3456A. If this may happen, refer the instrument to a Service Trained Person.

3. Syntax Error. A Syntax Error is when invalid programs codes are sent to the 3456A. An invalid program code is F9.

f. Program Memory Error. This error occurs under the following two conditions.

1. When trying to execute the program memory from memory (program codes X1 in program memory) and when enabling the Internal Test from memory (program codes TE1 in memory). Both conditions terminate the Program Memory Operation.

2. When exceeding internal memory space during program memory loading (storing more than 1400 bytes into memory).

g. Limits Failure. A Limits Failure occurs when a limit is exceeded in the 3456A's Pass/Fail math operation. More information on the Pass/Fail feature is in Paragraph 3-81.

3-142. The Status Byte Message in Figure 3-10 is represented in octal code. Each bit, except for bit 6, indicates a particular Require Service condition. Bit 6 (seventh bit) is the Service Request bit and is true when service is required. The bit lets the controller know that a Require Service condition exists. Remember, set the SRQ mask to output the Require Service Message.

3-143. If the SRQ mask has been set for more than one condition, more than one bit of the Status Byte Message may be true. For example:

a. A Require Service condition sets bits 1, 2, and 6 true. (Remember, bit 6 is true for any Require Service.) The conditions are caused by Program Memory Execution Complete and Data Ready.

b. The Status Byte looks like:

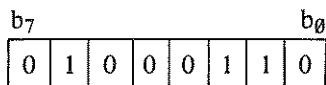

NOTE

A "1" in this example indicates a true condition.

c. The byte is output in octal code and the corresponding octal number is:

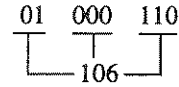

The resultant decimal number of octal 106 is 70.

3-144. Status Bit.

3-145. The 3456A does not respond to a Parallel Poll.

NOTE

The Status Bit is not part of the Status Byte Message and should not be confused with the bits in the Status Byte Message.

3-146. Pass Control.

3-147. The 3456A does not have controller capabilities.

3-148. Abort (Interface Clear).

3-149. All HP-IB communication is terminated, including the 3456A's Bus communication. Control is returned to the system controller. The Abort Message does not remove the 3456A from remote control.

3-150. 3456A Addressing.

3-151. HP-IB requires that a device on the Bus needs to be identified as a Listener or a Talker, in order to execute the Bus Messages and commands. Because of this requirement, each device on the HP-IB has a unique "listen" and "talk" address to distinguish themselves from each other. The device is then able to receive programming instructions when addressed to listen or sent data when addressed to talk.

3-152. The 3456A's address is set by the address switch located at the instrument's rear panel. The switch is a seven section "DIP" switch with five switches used for

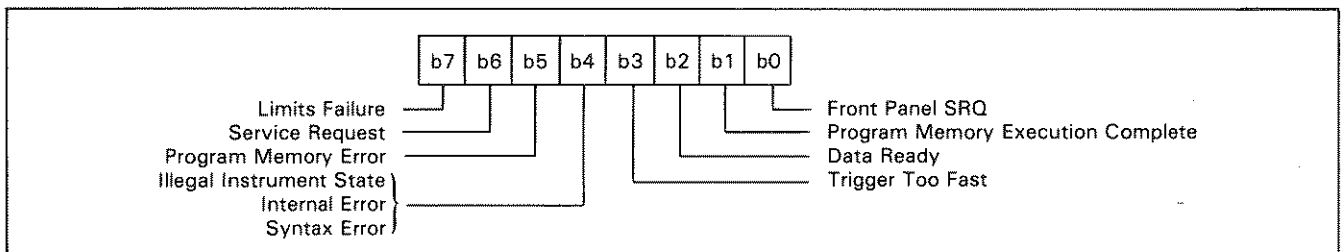

Figure 3-10. Status Byte.

address selection, as shown in Table 3-8. The sixth switch is not used and the seventh switch sets the instrument to the "Talk-Only" mode (see Paragraph 3-154). The 3456A's allowable address settings are listed in Table 3-8. Its factory address setting is a listen address of 22 decimal (ASCII character "6") and a talk address of 54 decimal (character "V").

NOTE

Setting the 3456A's Address Switch to the Listen Address' corresponding decimal code will also set the Talk Address.

3-153. Instrument address commands are usually in this form:

universal unlisten, device talk, device listen.

Table 3-8. 3456A Address Codes.

ASCII Code Character		Address Switches					5-bit Decimal Code
Listen	Talk	A5	A4	A3	A2	A1	
SP	@	0	0	0	0	0	00
!	A	0	0	0	0	1	01
"	B	0	0	0	1	0	02
#	C	0	0	0	1	1	03
\$	D	0	0	1	0	0	04
%	E	0	0	1	0	1	05
&	F	0	0	1	1	0	06
'	G	0	0	1	1	1	07
(H	0	1	0	0	0	08
)	I	0	1	0	0	1	09
*	J	0	1	0	1	0	10
+	K	0	1	0	1	1	11
,	L	0	1	1	0	0	12
-	M	0	1	1	0	1	13
.	N	0	1	1	1	0	14
/	O	0	1	1	1	1	15
0	P	1	0	0	0	0	16
1	Q	1	0	0	0	1	17
2	R	1	0	0	1	0	18
3	S	1	0	0	1	1	19
4	T	1	0	1	0	0	20
5	U	1	0	1	0	1	21
6	V	1	0	1	1	0	22 ← 3456A FACTORY Setting
7	W	1	0	1	1	1	23
8	X	1	1	0	0	0	24
9	Y	1	1	0	0	1	25
:	Z	1	1	0	1	0	26
;	[1	1	0	1	1	27
<	\	1	1	1	0	0	28
=]	1	1	1	0	1	29
>	~	1	1	1	1	0	30

The universal unlisten command removes all listeners from the HP-IB to allow only the addressed listener to receive information. The information is sent by a talker which is designated by the device talk code.

3-154. Talk-Only (No Controller).

3-155. Setting the 3456A to the "Talk-Only" mode can provide measurement data to another device, like a printer, without a Bus controller. The 3456A is placed to the "Talk-Only" mode by setting the rear "DIP" switch to the mode (set the seventh switch to "1"). Once this is done measurement data is output after each trigger. Instrument set up (function, range, etc.) is done from the front panel.

3-156. 3456A HP-IB Programming.

3-157. Now that the basic HP-IB operation is known, the next thing is to program and use the 3456A over the Bus. First, determine the measurement or instrument operation you want. Then determine the 3456A's program codes. The codes are ASCII characters transmitted over the HP-IB to the instrument.

3-158. Once you have defined the instrument criteria and program codes, next write an algorithm on how to make the measurement. When you have done this, convert the Algorithm to controller language. Refer to your controller's operating manual for the language.

3-159. Algorithm.

3-160. The algorithm should show exactly how to set up and use the instrument in a certain function. To simplify the algorithm, use the twelve Bus Messages as key words in the algorithm. The messages are repeated here for your reference.

1. DATA
2. TRIGGER
3. CLEAR
4. REMOTE
5. LOCAL
6. LOCAL LOCKOUT
7. CLEAR LOCKOUT AND SET LOCAL
8. REQUIRE SERVICE
9. STATUS BYTE
10. STATUS BIT
11. PASS CONTROL
12. ABORT

3-161. The definitions of the Bus Messages are given in this manual's Appendix A, Paragraph A-11. Remember, refer to your controller manual to convert the messages. If you have an -hp- Model 9825A Controller, the controller's Extended I/O Manual (-hp- Part Number 09825-90025) has a listing of the codes. For the 9835A/B, refer to the I/O Programming Manual (-hp- Part Number 09835-90060). If your controller manual does not have a code conversion chart, you may be able

to use the technical description of the messages located in Appendix A.

3-162. Here is an example Algorithm for the 3456A. Note that only the key words are used, not the codes.

a. In this algorithm, the 3456A is set up to make a DCV measurement, output it over the HP-IB and print the reading. The program ends if the 3456A sends a Require Service Message. The algorithm is as follows.

1. ABORT all previous operations
2. Set the 3456A to REMOTE
3. CLEAR the 3456A
4. LOCAL LOCKOUT the Instrument
5. Send DATA to set up the 3456A to
 - a) the dc function
 - b) autorange
 - c) hold trigger
 - d) set SRQ mask to Illegal Instrument State, Internal Error, and Syntax Error.
6. TRIGGER the 3456A
7. Send the measurement DATA to the controller and store in a variable
8. Check the 3456A to see if it REQUIRE's SERVICE
9. If REQUIRE SERVICE, check the STATUS BYTE; otherwise skip the next step
10. If the 3456A sent the STATUS BYTE, it did REQUIRE SERVICE and the program is ended
11. Print out the DATA from the variable
12. CLEAR LOCKOUT AND SET LOCAL
13. End program

3-163. Programming the 3456A over the HP-IB.

3-164. Programming the 3456A is done by DATA messages. Remember, DATA is sent or received. The DATA received by the 3456A is for instrument set up (function, range, etc.). The DATA sent by the 3456A is output data. Included in the following paragraph are programming examples of the Bus Messages and the algorithm. They are given in the HP-IB format, HPL (9825A Controller Language), and Enhanced Basic (9835A/B and 9845B Controller Language).

3-165. Program Codes (Data received by the 3456A).

3-166. Program codes are used for the 3456A's set up information. A listing of the codes is in Table 3-9. The instrument must be in "remote" and "listen" to receive the codes. An example is as follows.

a. HP-IB Format:

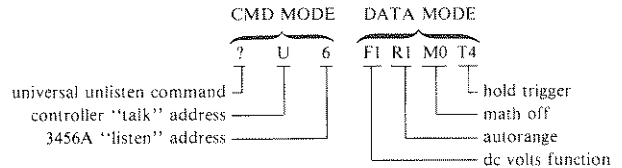

b. HPL (9825A Controller Language).

wrt 722, "F1 R1 M0 T4"

c. Enhanced Basic (9835A/B, 9845B Controller Language).

OUTPUT 722; "F1 R1 M0 T4"

NOTE

The "7" in the "722" address code is the 9825A, 9835A/B and 9845B Controllers I/O Card select code.

NOTE

The spaces between the program codes (F1spaceR1, etc.) shown in the example are not necessary. They are only included to separate the different program codes.

3-167. Storing into Registers (Y, Z, Delay, etc.) over the HP-IB.

3-168. Storing into register is similar to the front panel method. First enter the number to be stored and then store it into the register. The following examples shows how to do it, by storing "10" into the Number of Readings/Trigger register. The DCV function's program codes is also included in the example to show that other than register program codes can be in the same string.

a. HP-IB Format.

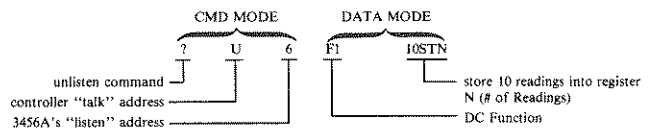

b. HPL (9825A Controller Language).

wrt 722, "F1 10STN"

Table 3-9A. 3456A Program Codes.

	Control	Program Code	
FUNCTION	Shift Function Off (Unshifted)	S0	
	DCV	F1	
	ACV	F2	
	ACV + DCV	F3	
	2 Wire K Ohms	F4	
	4 Wire K Ohms	F5	
	Shift Function On (Shifted)	S1	
	DCV/DCV Ratio	F1	
	ACV/DCV Ratio	F2	
	ACV + DCV/DCV Ratio	F3	
	O.C. 2 Wire K Ohms	F4	
	O.C. 4 Wire K Ohms	F5	
	RANGE	Auto	R1
		100 mV or .1 K Ohms	R2
		1000 mV or 1 K Ohms	R3
10 V or 10 K Ohms		R4	
100 V or 100 K Ohms		R5	
1000 V or 1 M Ohms		R6	
10 M Ohms		R7	
100 M Ohms		R8	
1000 M Ohms		R9	
TRIGGER		Internal	T1
	External	T2	
	Single	T3	
	Hold	T4	
AUTOZERO	On	Z1	
	Off	Z0	
FILTER	On	FL1	
	Off	FL0	
TEST	On	TE1	
	Off	TE0	
REGISTERS	Storing into Registers	ST	
	Recalling Registers	RE	
	Number of Readings	N	
	Number of Digits Displayed	G	
	Number of Power Line Cyc. Int.	I	
	Delay	D	
	Mean Register (Read only)	M	
	Variance Register (Read only)	V	
	Count Register (Read only)	C	
	Lower Register	L	
	R Register	R	
	Upper Register	U	
	Y Register	Y	
Z Register	Z		
MATH	Off	M0	
	Pass/Fail	M1	
	Statistic (Mean, Variance, Count)	M2	
	Null	M3	
	dBm	M4	
	Thermistor (°F)	M5	
	Thermistor (°C)	M6	
	Scale [(X - Z)/Y]	M7	
	%Error [(X - Y)/Y x 100]	M8	
	dB (20 Log X/Y)	M9	
READING STORAGE	On	RS1	
	Off	RS0	
SYSTEM OUTPUT MODE	On	SO1	
	Off	SO0	
DISPLAY	On	D1	
	Off	D0	
OUTPUT FORMAT	Packed Format On	P1	
	Packed Format Off (ASCII Format)	P0	
CLEAR-CONTINUE	Active	CL1	
NUMERIC SEPARATOR	Separates Numbers (e.g. F1W10STN)	W	
HOME COMMAND	Software Reset	H	
FRONT/REAR SWITCH SENSE	1 = Front, 0 = Rear	SW1	
EOI	Enable	O1	
	Disable	O0	
PROGRAM MEMORY	Load Program (Syntax) On	L1	
	Load Program (Syntax) Off	Q	
	Execute Program Memory	X1	

c. Enhanced Basic (9835A/B, 9845B Controller Language).

OUTPUT 722; "F1 10STN"

In the example, "F1" and "10STN" is separated by a space to keep the numbers apart. This is not necessary but may be less confusing. You can, however, enter a "W" instead of a space. The "W" is ignored by the 3456A but can be used to separate numerical entries from commands. The same program string with "W" looks like this:

"FIW10STN"

3-169. Programming the SRQ Mask.

3-170. Program codes are used to set the SRQ Mask. Use the programming procedure in Paragraph 3-165 to send the codes. Remember, the 3456A has to be in "remote" and "listen" to receive the codes. Since the Status Byte Message is in octal, the mask is programmed in octal by using the corresponding octal codes of the message. For example, bit 2 (Data Ready) is to be set and is done by sending its octal code, 004. The following example illustrates this.

a. HP-IB Format.

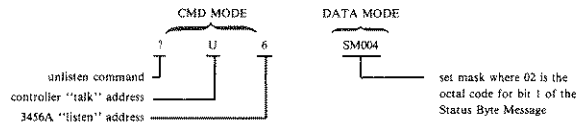

b. HPL (9825A Controller Language).

wrt 722, "SM004"

c. Enhanced Basic (9835A/B, 9845B Controller Language).

OUTPUT 722; "SM004"

3-171. Any, all, or combinations of the Require Service conditions can be set by programming the SRQ mask. All the bits can be disabled by programming the mask to "000".

3-172. 3456A's Measurement DATA (Data sent by the 3456A).

3-173. 3456A measurement data can be sent to the controller in two different formats, ASCII or Packed Format. The following explains the formats.

3-174. ASCII Format.

3-175. Output Statement. The 3456A's output data in the ASCII Format consists of 14 bytes and is in this form:

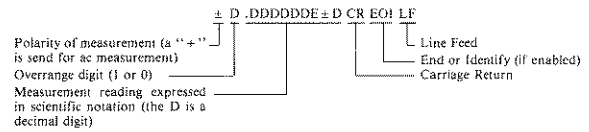

NOTE

The decimal point in the output statement is "free field" and can move to any place on the left side of the "E" and the right of the overrange digit.

Each character in the output statement is one byte and adds up to 14 bytes (the Carriage Return and Line Feed are one character each). The first digit (D) is the overrange digit and is either "1" or "0". The decimal point can be anywhere between the right of the overrange digit (shown in this example) and the left of the exponent ("E"). The Carriage Return and Line Feed are used to terminate the output statement. The End or Identify (EOI) line is normally set by the 3456A prior to the Line Feed if enabled. The EOI statement can be disabled over the HP-IB (see Paragraph 3-186).

3-176. Overload Output Statement. The output statement from an overload condition is in this form:



The overload polarity depends on the type of overload condition. A "+" is normally output when a measurement overload is present. A "-" can be output when a math overload condition is present.

3-177. Multiple Reading Output. The output statement for multiple readings (Number of Readings per Trigger feature) is similar to the normal output statement. The only difference is that no Carriage Return (CR), Line Feed (LF), and End or Identify (EOI) is output until all readings are taken. A comma (,) is used in their place to separate the readings. An example for 3 multiple readings is as follows:

+ D.DDDDDDE + D,-DD.DDDDE + D,
+ DDD.DDDDE-D CR EOI LF

3-178. Packed Format.

3-179. Unlike the ASCII Format, the Packed Format outputs 4 bytes instead of 14. A faster reading transfer is possible using the Packed Format. Before the 3456A can output readings in the packed mode, it must be remotely programmed. The codes are "P1" (see Table 3-9) to enable and "P0" to disable the Packed Format. The ASCII Format is automatically selected at turn-on.

3-180. Output Statement. Once the 3456A is programmed to output data in the Packed Format, each measurement is output in 4 bytes. Each byte shows a certain part of the measurement data. Here is a graphic description of the packed mode.

First Byte

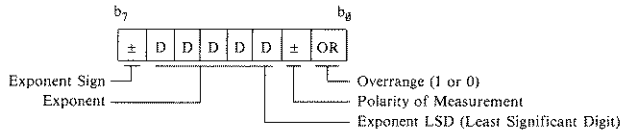

NOTE

The decimal point in the Packed Format is implied to the Overrange Digit's left.

Second Byte

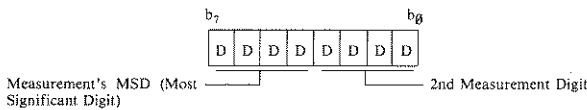

Third Byte

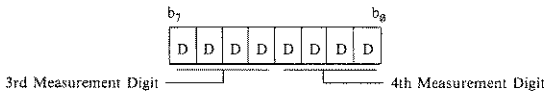

Fourth Byte

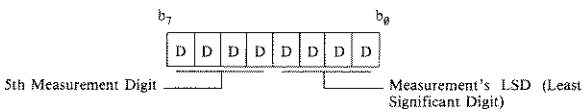

The sign (polarity) is indicated with “+” as a “0” and “-” as a “1”. The exponent and the measurement digits are in packed Binary Coded Decimal (BCD). The decimal point is implied to the overrange digit's left. The End or Identify (EOI) line is normally set prior to the 4th byte.

3-181. Overload Output Statement. The Overload Output Statement in the Packed Format follows the same number convention as the ASCII overload statement. The difference is that the numbers representing the overload condition is output in the Packed mode.

3-182. Multiple Reading Output. No delimiters are used between the readings with the End or Identify (EOI) being suppressed. The EOI will not be activated until all readings are output.

3-183. Unpacking the Packed Output. Since only four bytes of data is output in the Packed Format, some sort

of unpacking should be done for the reading(s) to make sense. This is done simply by converting each 8 bit binary number to a decimal number. An unpacking program using Enhanced Basic (9835A/B, 9845B Controller Language) is in Appendix A.

3-184. Reading the 3456A's Output Data.

3-185. First choose the output format you wish to use. The ASCII Format is chosen in this example. To output data, the 3456A has to be addressed to “talk” and the device receiving the data is the listener. Here is an example.

a. HP-IB Format.



b. HPL (9825A Controller Language).

red 722,A

c. Enhanced Basic (9835A/B, 9845B Controller Language).

ENTER 722;A

NOTE

Although it is not specified in the HP-IB Format, the output of the 3456A is normally stored in a variable. This is the reason why variable “A” is used in the controller language examples.

3-186. Disabling the End or Identify (EOI) Statement.

3-187. The End or Identify (EOI) statement can be disabled over the HP-IB for a faster transfer of readings. This is done by sending program codes “O0” to the 3456A using the programming procedure in Paragraph 3-165. Disabling the EOI statement and using the 3456A's Internal Trigger mode allows the faster possible reading transfer. The EOI statement is enabled by sending codes “O1” and at turn-on.

3-188. System Output Mode.

3-190. With the 3456A's System Output Mode enabled, a new measurement cycle is not initiated until the present reading is output by the instrument. The reading is output by addressing the 3456A to “talk”. Once this is done, a new measurement cycle is started. As long as the System Output mode is enabled and no reading is output, the instrument does not take any new readings. The mode is an advantage when using controllers slower than the 3456A. For example, if the Number of

Readings per Trigger operation is selected to output readings, the readings are output one after another. A slow controller may not be able to accept the readings at the 3456A's output speed and lose some or all readings. The System Output mode prevents this from happening. The 3456A waits until the controller is able to receive data. The mode is enabled by sending program codes "SO1" and disabled by codes "SO0". Use the programming procedure in Paragraph 3-165 to send the codes.

3-191. Home Command.

3-192. The Home Command is used to reset the 3456A to the same conditions as sending the CLEAR message, except faster. The differences between Home, Clear, Reset, and Turn-On are listed in Table 3-6. The Home Command is sent by program code "H" using the programming procedure in Paragraph 3-165.

3-193. Front/Rear Switch Position.

3-194. The Front/Rear Switch position can be remotely determined over the HP-IB. This is done by sending program codes "SW1" to the 3456A and then reading its output. If "0" is output, the switch is set to REAR and "1" indicates FRONT. Use the programming procedure in Paragraph 3-165 to send the codes and the procedure in Paragraph 3-184 to read the output data (switch position). The output is as follows:

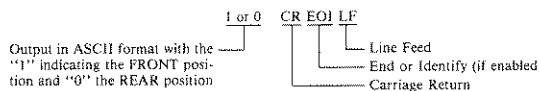

3-195. Complete Program Example.

3-196. After you know how to program the 3456A using the HP-IB, the next step is to write a program of the algorithm in Paragraph 3-162. Again, the program is given in the HP-IB Format, HPL (9825A Controller Language), and Enhanced Basic (9835A/B, 9845B Controller Language).

a. HP-IB Format.

- 1. Interface clear ABORT all previous operation
- 2. ?U6 REMOTE the 3456A
- 3. ?U6 004 CLEAR the instrument
- 4. 021 LOCAL LOCKOUT the 3456A (including the other devices on the controller's select code)
- 5. ?U6 Send DATA to set up the instrument to the dc function, autorange, hold trigger, and set SRQ bit 4 mask (15 is CR and 12 is LF)
- FIR1T4SM020 15
- 12
- 6. ?U6 010 TRIGGER the 3456A

- 7. ?U5V Send the measurement DATA to the controller and store in a variable
- +D.DDDDDDE+D
- 015 EOI 012
- 8. ?5V 030 If REQUIRE SERVICE, check the STATUS BYTE; otherwise skip the next step (the 030 is the Serial Poll enable)
- 9, 10. 031 No STATUS BYTE is sent by the 3456A (the 031 is the Serial Poll disable)
- 11. Controller Language Print out the DATA in variable A
- 12. ?U, 001 CLEAR LOCKOUT AND SET LOCAL (in this case, only for the 3456A)
- 13. Controller Language Ends the program

b. HPL (9825A Controller Language).

- 0: cli 7 ABORT
- 1: rem 722 REMOTE 3456A
- 2: clr 722 CLEAR 3456A
- 3: llo 7 LOCAL LOCKOUT
- 4: wrt 722, DATA. Set up instrument
- "FIR1T4SM020"
- 5: trg 722 TRIGGER 3456A
- 6: red 722,A DATA. Output of 3456A into variable
- 7: rds (722) - S REQUIRE SERVICE?
- 8: if S=0; goto 10 If no STATUS BIT, skip the next line
- 9: stp Stop the program
- 10: prt A Print output DATA in variable
- 11: lcl 722 CLEAR LOCKOUT AND SET LOCAL (3456A)
- 12: end Ends the program

c. Enhanced Basic (9835A/B, 9845B Controller Language).

- 10 ABORTIO 7 ABORT
- 20 REMOTE 722 REMOTE 3456A
- 30 CLEAR 722 CLEAR 3456A
- 40 LOCAL LOCAL LOCKOUT
- LOCKOUT 7
- 50 OUTPUT 722; DATA. Set up instrument
- "FIR1T4SM020"
- 60 TRIGGER 722 TRIGGER 3456A
- 70 ENTER 722;A DATA. Output of 3456A into variable
- 80 STATUS 722;S REQUIRE SERVICE?
- 90 IF S=0 THEN If no STATUS BIT, skip the next line
- GOTO 110
- 100 STOP Stop the program
- 110 PRINT A Print output DATA in variable

120 LOCAL 722 CLEAR LOCKOUT AND SET LOCAL
 130 END Ends the program

3-197. The information you have received in the preceding paragraphs should give you a good start in programming the 3456A over the HP-IB. The following paragraphs explain some more unique remote operations.

3-198. Front Panel SRQ.

3-199. The Front Panel SRQ feature of the 3456A outputs a Require Service Message when the Front Panel SRQ button is pressed. Before this can take place, set bit 0 on the SRQ mask (refer to Paragraph 3-169 to set the mask). Once this is done, press the SRQ button. The front panel SRQ LED will turn on and the Require Service Message is output. This condition will remain until the SRQ button is pressed a second time or a Serial Poll is done by the controller.

3-200. Instrument Program memory Operation.

3-201. With this feature, you can store into the 3456A's internal memory any valid remote operations (excluding Test and Program Memory Execution) using program codes. Total available memory size is 1400 bytes. Because a program code takes one byte of memory you can store 1400 codes. The memory is also used with Reading Storage and any stored codes takes space away for storing readings.

3-202. **Storing Program Codes.** The 3456A has to be told to store into its internal memory. The program used are "L1" to enable the storage and "Q" to disables the storage. This is illustrated in the following example.

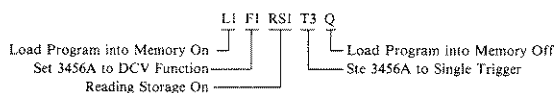

Program codes "L1" and "Q" are not stored into memory. The total memory used is 7 bytes. The codes remain in memory until the 3456A is turned off (Reset, Clear, and Home do not clear the memory). The memory can be cleared by sending codes "L1Q".

NOTE

Unlike regular remote operation, program memory only ignores blanks. Other invalid characters can produce a Syntax Error during program memory execution.

3-203. **Program Execution.** Once the program codes are stored in memory they can be executed. This is done by sending program codes "X1" to the 3456A. The instrument then performs the operation. In the previous

example, when Program Memory is executed, a dc reading is taken and stored into memory.

NOTE

The Execute (X1) and Internal Test (TE1) codes can cause a program memory execution error.

NOTE

With Home (H) command stored in program memory while executing the memory the 3456A is reset to the Turn-On state and stops the program memory operation.

3-204. **Multiple Operations.** You can store and execute more than one remote operation into memory. For example, the 3456A can be programmed to do a DCV measurement, Trigger it, do an ACV measurement, Trigger it, and so on. The next example illustrates this.

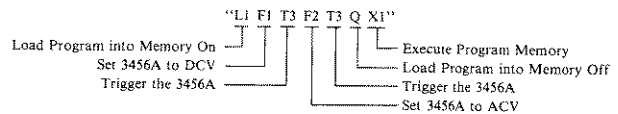

3-205. **Recall of Readings from Memory.** Readings are remotely recalled and output from memroy similar to the front panel recall operation (see Paragraph 3-104). This is done by storing into register R the corresponding number of the reading you wish to recall. Then recall the register and output the reading. The following procedure illustrates this operation. In the procedure, reading #1 and #2 are to be recalled.

a. Set the 3456A to listen. Sent the program codes for Hold Trigger, Reading Storage On, and store a "1" (reading #1) into register R.

"T4 RS1 1STR"

b. Sent program codes to recall the R register.

"RER"

c. Set the 3456A to talk. Output the reading (#1) over the HP-IB.

d. Set the 3456A to listen. Sent the program codes to store a "2" (reading #2) into register R.

"2STR"

e. Sent program codes to recall the R register.

"RER"

f. Set the 3456A to talk. Output the reading (#2) over the HP-IB.

NOTE

Make sure the 3456A is programmed to Hold or Single Trigger when recalling readings.

The remote recall operation is similar to the front panel operation. Scrolling is also done similar to front panel operation. An example to scroll the readings, starting with #10, is as follows.

a. Set the 3456A to listen. Sent program codes for Hold Trigger, Reading Storage On, and store "-10" into register R. (The -10 is used to scroll the readings starting with reading #10.)

"T4 RS1 -10STR"

b. Sent program codes to recall the R register.

"RER"

c. Set the 3456A to talk. The readings are now output over the HP-IB starting with reading #10 and ending with #1.

In the example, multiple readings are output the same as explained in paragraph 3-177. A program example using HPL (9825A Controller Language) and Enhanced Basic (9835A/B and 9845B Controller Language) is given in Appendix A.

3-206. Data Ready.

3-207. The Data Ready feature, when enabled, outputs a Require Service Message for a completed measurement cycle. The SRQ mask has to be set before the message is output. Set the mask by sending program codes "SM004" (for bit 2 of the Status Byte). When the Require Service message is sent, the front panel SRQ LED is on. The LED remains on until a new measurement cycle is started (the 3456A is triggered), when the present reading is output over the HP-IB, or when the 3456A is polled (Serial Poll). If the 3456A is set up to take a number of readings per trigger, the require service condition will be true, at the end of each reading,

for about 320µs. The condition will remain true and the SRQ LED turns on, after all the readings are taken.

3-208. 3456A's Numeric Entry Format and other Input Considerations.

3-209. The 3456A's Numeric Entry Format (used in program codes) are in this form:

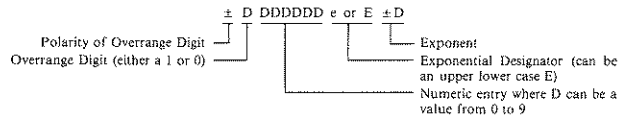

The decimal point is optional and ranges from the right of the overrange digit to the Exponential Designator's left.

3-210. When sending data to the 3456A in remote, all lower case (except "e") alpha characters, spaces, carriage return, and line feed are ignored. All other invalid ASCII characters are illegal. The optional "W" character can be used as a prefix to a numeric string like this"

F1W10STN

3-211. OPERATOR'S CHECK.

3-212. The following is an Operator's Check you can perform to check the major DCV, ACV, Ohms, and Digital circuitry. The checks are not used to verify performance accuracy. They are only used to check the operating capabilities of the 3456A. The following can be used as the Operator's Check.

a. Remove everything from the 3456A's input terminals.

b. press the TEST button. The display should go blank while doing an internal test. When the test passes and is completed, +1.8.8.8.8.8.8. +8. is displayed including all of the front panel LEDs. The cycle will then be repeated. If a negative integer is displayed, refer the 3456A to a service trained person. Press the TEST button a second time.

APPENDIX A

A-1. INTRODUCTION.

A-2. The following chapters in this appendix contain certain general and specific HP-IB information. The general information is non-controller dependent but may be dependent on the 3456A. The specific information is controller and/or instrument dependent.

A-3. GENERAL HP-IB DESCRIPTION.

A-4. The Hewlett-Packard Interface Bus (HP-IB) is a carefully defined interface which simplifies the integration of various instruments, calculators, and computers into systems. The interface provides for messages in digital form to be transferred between two or more HP-IB compatible devices. A compatible device can be an instrument, calculator, computer, or peripheral device that is designed to be interfaced using the HP-IB.

A-5. The HP-IB is a parallel bus of 16 active signal lines grouped into three sets, according to function, to interconnect up to 15 instruments. A diagram of the Interface Connections and Bus Structure is in Figure A-1.

A-6. Eight signal lines, termed as DATA lines, are in the first set. The Data lines are used to transmit data in the form of coded messages. These messages are used to program instrument function, transfer measurement data, coordinate instrument operation, and to manage the system. This allows you to set-up the instrument and read its measurement data. Input and output of messages in bit-parallel, byte-serial form are also transferred in the Data lines. A 7-bit ASCII code normally represents each piece of DATA.

A-7. Data is transferred by means of an interlocking "handshake" technique which permits data transfer (asynchronously) at the rate of the slowest active device used in that particular transfer. The three DATA BYTE CONTROL lines coordinate the transfer and form the second set of lines.

A-8. The remaining five GENERAL INTERFACE MANAGEMENT lines are used to manage the devices on the HP-IB. This includes activating all connected devices at once, clearing the interface, and others. A condensed description of the HP-IB is available in the

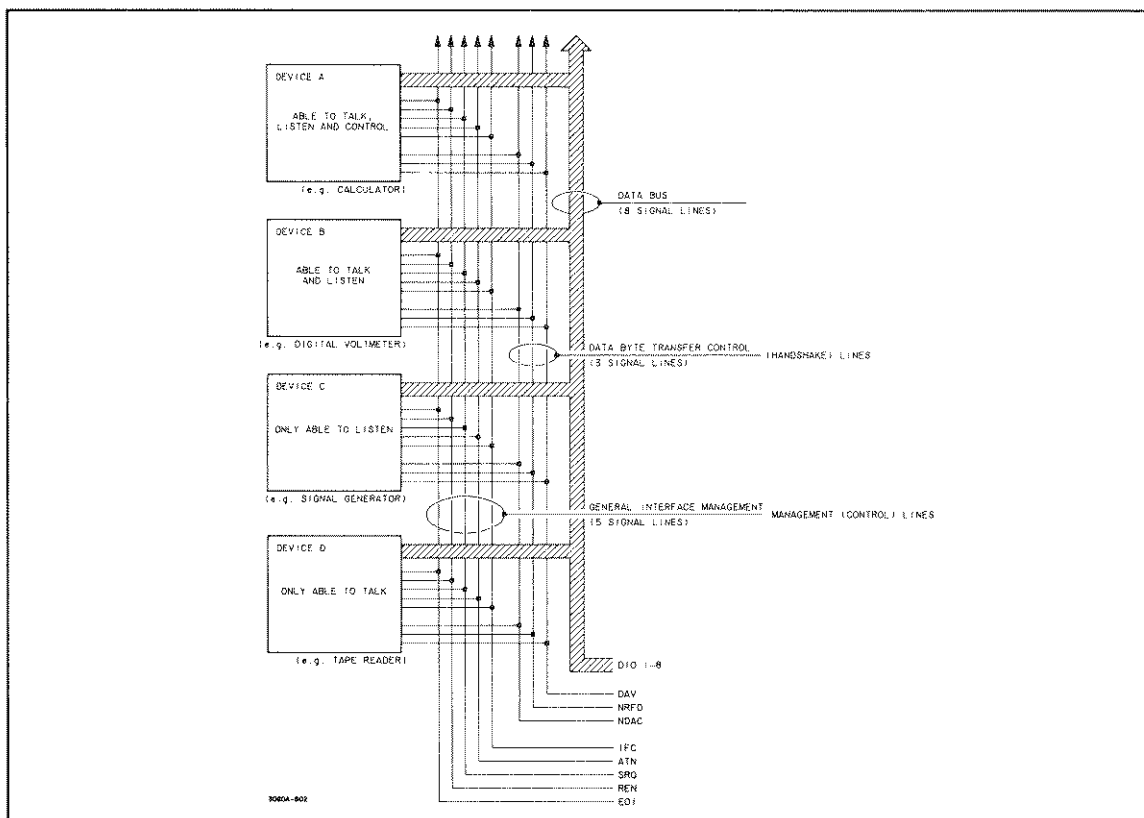

Figure A-1. Interface Connection and Bus Structure.

Condensed Description of the Hewlett-Packard Interface Bus Manual, -hp- Part Number 59401-90030. The manual is available through your nearest -hp- Sales and Service Office.

A-9. HP-IB SYSTEM OVERVIEW.

A-10. The following chapters define the terms and concepts used to describe HP-IB (Bus) system operations.

A-11. HP-IB System Terms.

a. Address: The characters sent by a controlling device to specify which device will send information on the HP-IB and which device(s) will receive that information. Addressing may also be accomplished by hardwiring a device to only send information or only receive information.

b. Byte: A unit of information consisting of 8 binary digits (bits).

c. Device: A unit that is compatible with the IEEE Standard 488-1975.

d. Device Dependent: An action a device performs in response to information sent over the HP-IB. The action is characteristic of an individual device and may vary from device to device.

e. Polling: This process typically is used by a controller to locate a device that needs to interact with the controller. There are two types of polling, as follows:

1. Serial Poll: This method obtains one byte of operational information about an individual device in the system. The process must be repeated for each device from which information is desired.
2. Parallel Poll: This method obtains information about a group of devices simultaneously.

A-12. Basic Device Communication Capabilities.

A-13. Devices which communicate along the interface bus can be classified into three basic categories:

a. Talker: Any device that is able to send information over the HP-IB, when it has been addressed. Only one talker may be active at a time; usually the one that is currently directed to send data. All HP-IB type calculators and computers are generally talkers.

b. Listener: Devices which receive information over the HP-IB, when they have been addressed. A device may or may not be both a talker and a listener. Calculators or computers are generally both a talker and a listener (at different times).

c. Controller: The device that can specify which

devices(s) on the Bus is a talker or a listener. There can be two types of controllers, an Active Controller and a System Controller. The Active Controller is the current controlling device. The System Controller can, however, take control of the HP-IB even if it is not the active controller. There can also be only one controller at a time, even if several controllers are on the Bus.

A-14. HP-IB Messages.

A-15. Different types of information can be passed over the HP-IB to one or more devices. Some of this information is in the form of messages, most of which can be separated into two parts. One part can be classified as the address portion specified by the controller and the information that comprises the messages. The second part can be classified as HP-IB management messages. These messages are comprised of twelve messages and are called meta messages. In this manual they are referred to as Bus Messages and are defined as follow.

a. Data: The actual information (binary bytes) sent by a talker to one or more listener. The information (data) can either be in a numeric form or a character string.

b. Trigger: The trigger message causes the listening device or devices to perform a device dependent action when addressed.

c. Clear: The clear message causes the listening device(s) or all of the devices on the HP-IB to return to their predefined device-dependent state.

d. Remote: This message causes the listening device(s) to switch from local front panel control to remote program control when addressed to listen.

e. Local: This message clears the REMOTE message from the listening device(s) and returns the device(s) to local front panel control.

f. Local Lockout: This message prevents a device operator from manually inhibiting remote program control.

g. Clear Lockout and Set Local: With this message, all devices are removed from the local lockout mode and revert to local. The remote message is also cleared for all devices.

h. Require Service: A device can send this message at any time to signify the device needs some type of interaction with this controller. The message is cleared by the device's STATUS BYTE message if the device no longer requires service.

i. Status Byte: A byte that represents the status of a single device on the HP-IB. One bit indicates whether the device sent the required service message and the re-

maining seven bits indicate operational conditions defined by the device. This byte is sent from the talking device in response to a "Serial Poll" operation performed by the controller.

j. Status Bit: A byte that represents the operational conditions of a group of devices on the HP-IB. Each device responds on a particular bit of the byte thus identifying a device dependent condition. This bit is typically sent by devices in response to a parallel poll operation.

k. Pass Control: The bus management responsibility is transferred from the active controller to another controller by this message.

l. Abort: The system controller sends this message to

unconditionally assume control of the HP-IB from the active controller. The message will terminate all bus communication but does not implement the CLEAR message.

A-16. HP-IB WORKSHEET.

A-17. The HP-IB Worksheet (Table A-1) can be used to determine the HP-IB capabilities of the other HP-IB compatible instruments may have. The sheet may be filled in with the Bus messages applicability for your controller and each HP-IB device. The Bus capability of the 3456A has already been filled in. Refer to your controller manual and the manual(s) of your other device(s) for their Bus Messages capabilities. Once the sheet is filled out, you should then have the HP-IB capabilities of your device(s).

Table A-1. HP-IB Worksheet.

MESSAGE	HP-IB BUS IMPLEMENTATION WORKSHEET									
	DEVICE									
INSTRUMENT IDENTIFICATION AND HP-IB ADDRESS	MODEL 3456A						MODEL			
	LISTEN YES						LISTEN			
	TALK YES						TALK			
	5 BIT VALUE 22						5 BIT VALUE			
DATA	S & R									
TRIGGER	R									
CLEAR	R									
LOCAL	R									
REMOTE	R									
LOCAL LOCKOUT	R									
CLEAR LO & SET LOCKOUT	R									
REQUIRE SERVICE	S									
STATUS BYTE	S									
STATUS BIT	N									
PASS CONTROL	N									
ABORT	N									

S = SEND ONLY R = RECEIVE ONLY S & R = SEND AND RECEIVE N = NOT IMPLEMENTED

A-18. UNPACKING PROGRAM.

The program is given in the Enhanced Basic (9835A/B and 9845B Controller) Language.

A-19. The following is an unpacking program used to unpack the 3456A's readings taken in the Packed mode.

Unpacking Program

```

10  ! The following program illustrates one method for unpacking data from
20  ! the 3456A. You can program this routine to take "any" number of readings
30  ! by changing the DIM statement in line 20, the 3456A programming syntax
40  ! in line 30, and the buffered transfer statement in line 40. The
50  ! numerical array Out is dimensioned to contain the number of readings that
60  ! will be taken. The string variable In$ is dimensioned to 4 times the
70  ! number of readings taken. That is, a packed reading contains 4 bytes of
80  ! data per reading.
90  !
100 ! In this particular example, the 3456A is programmed to the following
110 ! states:
120 ! Function: DCV (F1)
130 ! Data Output Format: Packed (P1)
140 ! Range: Autorange (R1)
150 ! Delay: 0 (0STD)
160 ! Integration Time: .1 Line Cycles (.1STI)
170 ! Number of Readings: 9 (9STN)
180 ! System Output Mode: On (SO1)
190 ! Trigger: Single (T3)
200 !
210 ! You can follow the comment statements on each line of the program to
220 ! understand the basic operation. Explaining the operation of the
230 ! unpacking subprogram is beyond the scope of this manual.
240 !
250 !
260 OPTION BASE 1 ! Specifies first element in numeric array Out is Out(1).
270 DIM In$[36],Out(9) ! Dimensions the string variable and numeric array.
280 OUTPUT 722:"P1F1R10STD.1STI9STNSO1T3" ! Programs the 3456A.
290 ENTER 722 BFHS 36 NOFORMAT;In$ ! Enters 36 data bytes into the string In$.
300 CALL Unpk56(In$,Out(9)) ! Calls Unpacking routine; passes the packed data.
310 FOR I=1 TO 9 ! Sets up loop to print out the number of readings taken.
320 PRINT "NUMBER ";I;" VOLTAGE READING = ";Out(I)
330 NEXT I
340 END
350 SUB Unpk56(In$,Out(9))
360 INTEGER N,J,I,B1,B2,B3,B4
370 N=LEN(In$)
380 J=0
390 FOR I=1 TO N STEP 4
400 J=J+1
410 B1=NUM(In$[I])
420 B2=NUM(In$[I+1])
430 B3=NUM(In$[I+2])
440 B4=NUM(In$[I+3])
450 Out(J)=.1*BIT(B1,0)+.01*SHIFT(B2,4)+.001*BINAND(B2,15)+.0001*SHIFT(B3,4)+
.00001*BINAND(B3,15)+.000001*SHIFT(B4,4)+.0000001*BINAND(B4,15)
460 Out(J)=Out(J)*((1-2*BIT(B1,1))*10↑((1-2*BIT(B1,7))*SHIFT(BINAND(B1,124),2)))
470 NEXT I
480 SUBEND

```

A-20. MULTIPLE READING TRANSFER PROGRAMS.

A-21. The following programs show how to transfer multiple readings from the 3456A to the controller. The programs are given in the HPL(9825A Controller) and Enhanced Basic (9835A/B and 9845B Controller) Language. The programs do the following.

- a. The 3456A is set up to do this:
 1. Clear the 3456A and set SRQ Mask to bit 1 (Program Memory Execution Complete).
 2. Enter into memory to enable Reading Storage, select 10 Number of Readings per Trigger, and Single Trigger.
 3. Execute Program Memory.
- b. Read 3456A Status and remain in a loop until Program Memory has completed its execution.
- c. Set up the 3456A to enable its System Output Mode and scroll the internally stored readings starting with #10.
- d. Store readings into variables.

HPL Program.

```

0: dim A[10]
1: wrt 722:"HSM002L1RS110STNT3QX1"
2: if rds(722)#661jmp 0
3: wrt 722:"S01-10STRRER"
4: for I=1 to 10
5: red 722:A[I]
6: next I
7: for I=1 to 10
8: prt A[I]
9: next I
10: end
*22514
    
```

Enhanced Basic Program

```

10 OPTION BASE 1
20 DIM A(10)
30 OUTPUT 723:"HSM002L1RS110STNT3QX1"
40 STATUS 723:S
50 IF S(>66 THEN GOTO 40
60 OUTPUT 723:"S01-10STRRER"
70 ENTER 723:A(*)
80 MAT PRINT A
90 END
    
```

A-22. BUS MESSAGE IMPLEMENTATION.

A-23. The following figures provide a description on the implementation of the Bus Messages using the 3456A. The codes used in the figures are:

- T = True
- F = False
- X = Don't Care
- oct = Octal Code

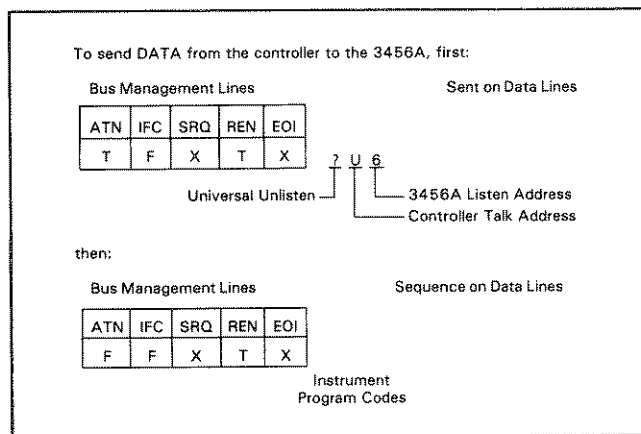

Figure A-2. Data Message (Controller to 3456A).

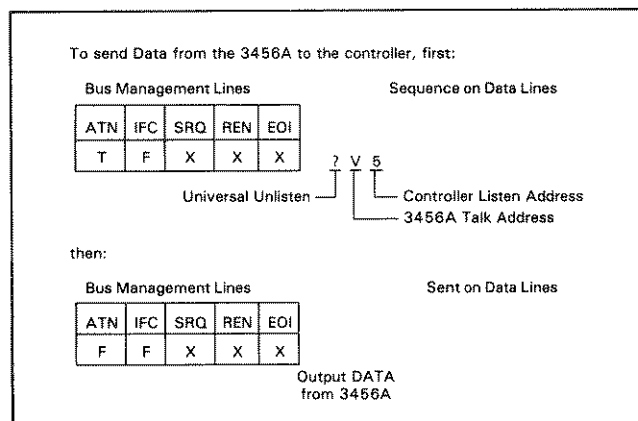

Figure A-3. Data Message (3456A to Controller or Other Device(s)).

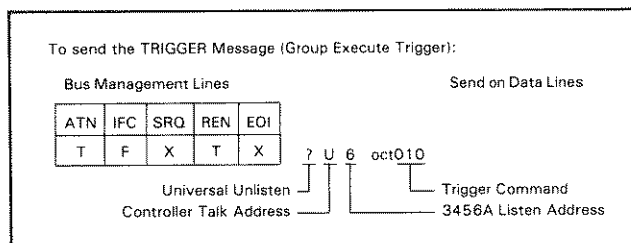

Figure A-4. Trigger Message (from Controller to Device(s)).

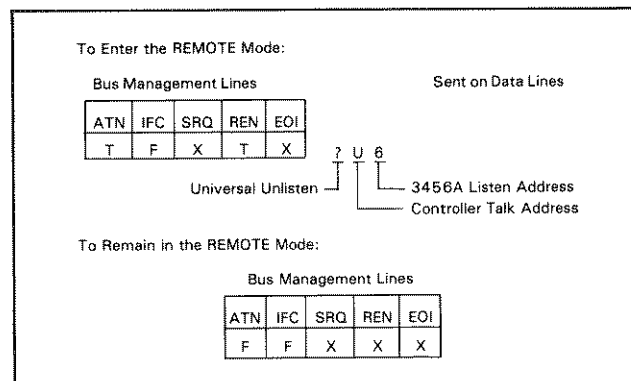

Figure A-5. Remote Message.

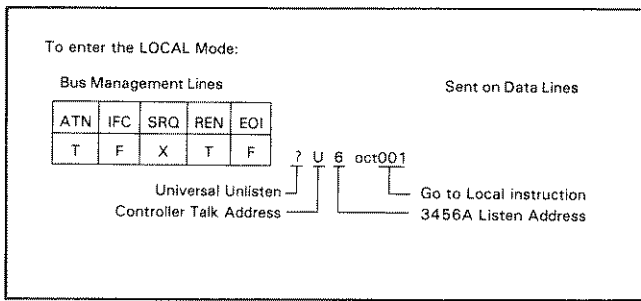

Figure A-6. Local Message.

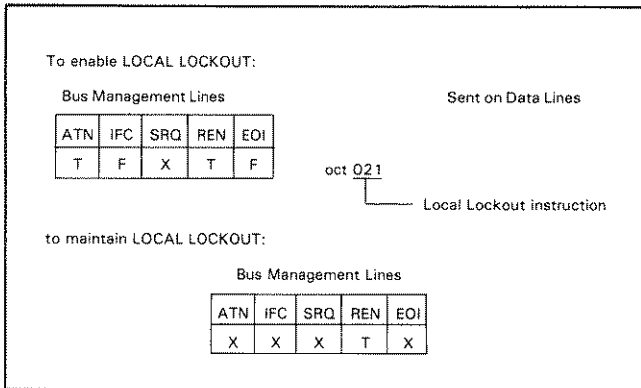

Figure A-7. Local Lockout Message.

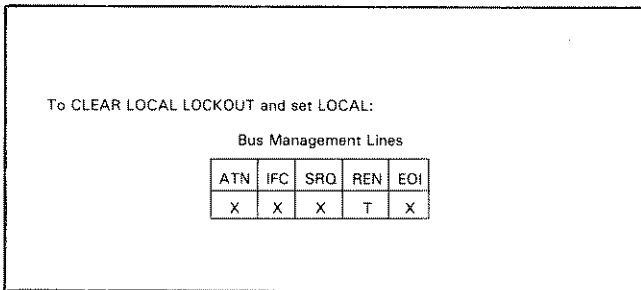

Figure A-8. Clear Lockout/Set Local Message.

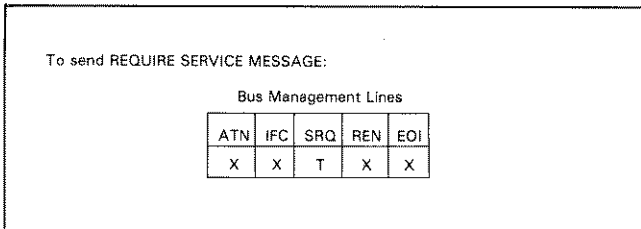

Figure A-9. Require Service Message.

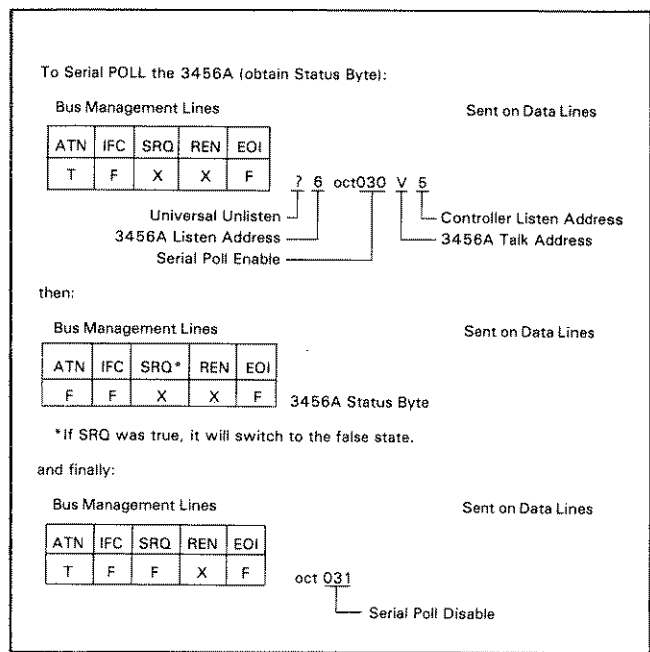

Figure A-10. Status Byte Message.

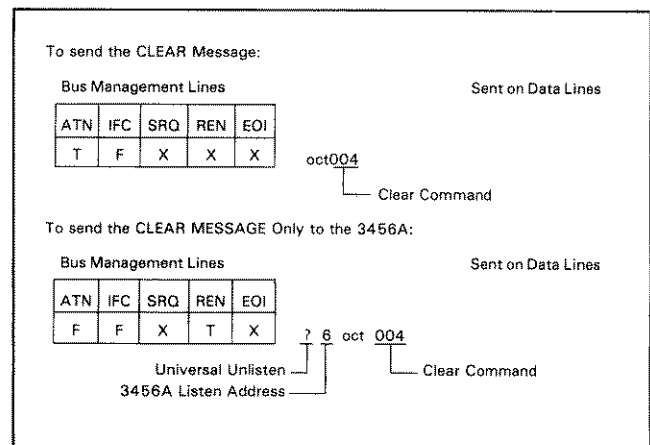

Figure A-11. Clear Message.

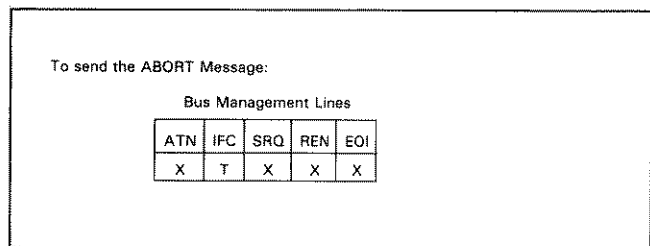

Figure A-12. Abort Message.

APPENDIX B

B-1. FRONT/REAR SWITCH LOCK PROCEDURE.

B-2. The Front/Rear Switch can be locked in either the FRONT or REAR position by the installation of a lock. The following procedures show how to install and remove the lock.

a. Lock Installation Procedure.

1. Locate the front panel section located at the front panel's input terminals.
2. Remove the front panel section by loosening the hold down screws located to the left and right of the panel. (Note: The screws are fastened to the panel section and should not be forced out of the section.)
3. Remove the switch cap from the Front/Rear Switch. The cap can be removed by holding the cap between the index finger and thumb and pulling it away from the switch.
4. Set the Front/Rear Switch to the desired position (FRONT or REAR).

5. Locate the Locking Cap and front panel section. Install the cap into the panel section's slot marked FRONT and REAR until it snaps in place. Make sure the arrow on the cap points to the lettering which corresponds to the Front/Rear Switch position.

6. Reinstall the front panel section into the front panel and tighten the screws.

b. Lock Removal Procedure.

1. Do step a and b of the Lock Installation Procedure.
2. Remove the lock from the front panel section. Do this by squeezing the cap's locking fingers and push the lock out of the slot. A pair of needlenose pliers or something similar can be used.
3. Locate the cap which was removed from the Front/Rear Switch when the lock was installed. Reinstall it on the Front/Rear Switch.
4. Reinstall the front panel section into the front panel and tighten the screws.



Product Line Sales/Support Key

Key Product Line
A Analytical
CM Components
C Computer Systems Sales only
CH Computer Systems Hardware Sales & Services
CS Computer Systems Software Sales & Services
E Electronic Instruments & Measurement Systems
M Medical Products
MP Medical Products Primary SRO
MS Medical Products Secondary SRO
P Personal Computing Products
 * Sales only for specific product line
 ** Support only for specific product line

IMPORTANT: These symbols designate general product line capability. They do not insure sales or support availability for all products within a line, at all locations. Contact your local sales office for information regarding locations where HP support is available for specific products.

HP distributors are printed in italics.

ANGOLA

Telectra
Empresa Técnica de Equipamentos
Eléctricos, S.A.R.L.
R. Barbosa Rodrigues, 41-1 DT.
Caixa Postal 6487
LUANDA
 Tel: 35515,35516
 E,M,P

ARGENTINA

Hewlett-Packard Argentina S.A.
 Avenida Santa Fe 2035
 Marlinéz 1640 BUENOS AIRES
 Tel: 798-5735, 792-1293
 Telex: 122443 AR CIGY
 Cable: HEWPACARG
 A,E,CH,CS,P

Biotron S.A.C.I.y.M
Av Paseo Colon 221, 9 Piso
1399 BUENOS AIRES
 Tel: 30-4846, 30-1851, 30-8384
 Telex: 17595 BION/AR
 M

Fate S.A. I.C.I./Electronica
Venezuela 1326
1095 BUENOS AIRES
 Tel: 379026, 379027
 Telex: 18137, 22754 ALVAR AR
 P

AUSTRALIA**Adelaide, South Australia Office**

Hewlett-Packard Australia Pty.Ltd.
 153 Greenhill Road
PARKSIDE, S.A. 5063
 Tel: 272-5911
 Telex: 82536
 Cable: HEWPARD Adelaide
 A*,CH,CM,,E,MS,P

Brisbane, Queensland Office

Hewlett-Packard Australia Pty.Ltd.
 5th Floor
 Teachers Union Building
 495-499 Boundary Street
SPRING HILL, Queensland 4000
 Tel: 229-1544
 Telex: 42133
 Cable: HEWPARD Brisbane
 A,CH,CM,,E,MS,P

Canberra, Australia Capital Territory Office

Hewlett-Packard Australia Pty.Ltd.
 121 Wollongong Street
FYSHWICK, A.C.T. 2609
 Tel: 80 4244 Telex: 62650
 Cable: HEWPARD Canberra
 A*CH,CM,E,MS,P

Melbourne, Victoria Office

Hewlett-Packard Australia Pty.Ltd.
 31-41 Joseph Street
BLACKBURN, Victoria 3130
 Tel: 89-6351
 Telex: 31-024
 Cable: HEWPARD Melbourne
 A,CH,CM,CS,E,MS,P

Perth, Western Australia Office

Hewlett-Packard Australia Pty.Ltd.
 141 Stirling Highway
NEDLANDS, W.A. 6009
 (effective 28 Sept. 1981:
 261 Stirling Highway
CLAREMONT, W.A. 6010)
 Tel: 386-5455
 Telex: 93859
 Cable: HEWPARD Perth
 A,CH,CM,,E,MS,P

Sydney, New South Wales Office

Hewlett-Packard Australia Pty.Ltd.
 17-23 Talavera Road
 P.O. Box 308
NORTH RYDE, N.S.W. 2113
 Tel: 887-1611
 Telex: 21561
 Cable: HEWPARD Sydney
 A,CH,CM,CS,E,MS,P

AUSTRIA

Hewlett-Packard Ges.m.b.h.
 Grottenhofstrasse 94
 Verkaufsburo Graz
A-8052 GRAZ
 Tel: 21-5-66
 Telex: 32375
 CH,CM,E*

Hewlett-Packard Ges.m.b.h.
 Wehlstrasse 29
 P.O. Box 7
A-1205 VIENNA
 Tel: (222) 35-16-210
 Telex: 135823/135066
 A,CH,CM,CS,E,MS,P

BAHRAIN

Green Salon
P.O. Box 557
BAHRAIN
 Tel: 25503-250950
 Telex: 84419
 P

Wael Pharmacy

P.O. Box 648
BAHRAIN
 Tel: 256123
 Telex: 8550 WAEI G.J
 M

BELGIUM

Hewlett-Packard Belgium S.A./N.V.
 Blvd de la Woluwe, 100
 Woluwedal
B-1200 BRUSSELS
 Tel: (02) 762-32-00
 Telex: 23-494 paloben bru
 A,CH,CM,CS,E,MP,P

BRAZIL

Hewlett-Packard do Brasil I.e.C.
 Ltda.
 Alameda Rio Negro, 750
ALPHAVILLE 06400 Barueri SP
 Tel: 421-1311
 Telex: 011 33872
 Cable: HEWPACK Sao Paulo
 A,CH,CM,CS,E,MS
 Hewlett-Packard do Brasil I.e.C.
 Ltda.
 Avenida Epitacio Pessoa, 4664
 22471 RIO DE JANEIRO-RJ
 Tel: 286-0237
 Telex: 021-21905 HPBR-BR
 Cable: HEWPACK Rio de Janeiro
 A,CH,CM,E,MS,P*

CANADA

Alberta
 Hewlett-Packard (Canada) Ltd.
 210, 7220 Fisher Street S.E.
CALGARY, Alberta T2H 2H8
 Tel: (403) 253-2713
 A,CH,CM,E*,MS,P*

Hewlett-Packard (Canada) Ltd.
 11620A-168th Street
EDMONTON, Alberta T5M 3T9
 Tel: (403) 452-3670
 A,CH,CM,CS,E,MS,P*

British Columbia

Hewlett-Packard (Canada) Ltd.
 10691 Shelbridge Way
RICHMOND, British Columbia V6X 2W7
 Tel: (604) 270-2277
 Telex: 610-922-5059
 A,CH,CM,CS,E*,MS,P*

Manitoba

Hewlett-Packard (Canada) Ltd.
 380-550 Century Street
WINNIPEG, Manitoba R3H 0Y1
 Tel: (204) 786-6701
 A,CH,CM,E,MS,P*

New Brunswick

Hewlett-Packard (Canada) Ltd.
 190 Wilbur Street
MONCTON, New Brunswick E2B 2V0
 Tel: (506) 386-1677
 Telex: 01931470
 CH**

Nova Scotia

Hewlett-Packard (Canada) Ltd.
 P.O. Box 931
 900 Windmill Road
DARTMOUTH, Nova Scotia B2Y 3Z6
 Tel: (902) 469-7820
 Telex: 01931470
 CH,CM,CS,E*,MS,P*

Ontario

Hewlett-Packard (Canada) Ltd.
 552 Newbold Street
LONDON, Ontario N6E 2S5
 Tel: (519) 686-9181
 Telex: 610-352-1201
 A,CH,CM,E*,MS,P*

Hewlett-Packard (Canada) Ltd.
 6877 Goreway Drive
MISSISSAUGA, Ontario L4V 1M8
 Tel: (416) 678-9430
 Telex: 610-492-4246
 A,CH,CM,CS,E,MP,P

Hewlett-Packard (Canada) Ltd.
 2670 Queensview Dr.
OTTAWA, Ontario K2B 8K1
 Tel: (613) 820-6483
 Telex: 610-563-1636
 A,CH,CM,CS,E*,MS,P*

Quebec

Hewlett-Packard (Canada) Ltd.
 17500 South Service Road
 Trans-Canada Highway
KIRKLAND, Quebec H9J 2M5
 Tel: (514) 697-4232
 Telex: 05821521
 A,CH,CM,CS,E,MP,P*

Hewlett-Packard (Canada) Ltd.
 Les Galeries du Vallon
 2323 Boulevard du Versant Nord
STE. FOY, Quebec G1N 4C2
 Tel: (418) 687-4570
 CH

CHILE

Jorge Calcagni y Cia. Ltda.
Arturo Burthie 065
Casilla 16475
SANTIAGO 9
 Tel: 222-0222
 Telex: Public Booth 0001
 A,CM,E,M

Olympia (Chile) Ltd.
Rodrico de Araya 1045
Casilla 256-V
SANTIAGO 21
 Tel: 225-5044
 Telex: 40565 OLYMP CL
 C,P

CHINA, People's Republic of

CEIEC Inc.
44 Beiwei Rd.
BEIJING, China
 Telex: 22475 CEIEC CN
 A,CH,CM,CS,E,P

COLOMBIA

Instrumentación
H. A. Langebaek & Kier S.A.
Apartado Aéreo 6287
BOGOTÁ 1, D.E.
Carrera 7 No. 48-75
BOGOTÁ, 2 D.E.
 Tel: 287-8877
 Telex: 44400
 Cable: AARIS Bogota
 A,CM,E,M,P

COSTA RICA

Científica Costarricense S.A.
Avenida 2, Calle 5
San Pedro de Montes de Oca
Apartado 10159
SAN JOSE
 Tel: 24-38-20, 24-08-19
 Telex: 2367 GALGUR
 CM,E,M

CYPRUS

Telerexa Ltd.
P.O. Box 4809
14C Stassinios Avenue
NICOSIA
 Tel: 62698
 Telex: 2894 Leviodoc
 E,M,P

CZECHOSLOVAKIA

Hewlett-Packard
Obchodni Zastupitelstvi v CSSR
Post. schranka 27
CS: 118 01 PRAHA 011
 Tel: 66-296
 Telex: 121353 IHC

DENMARK

Hewlett-Packard A/S
 Datavej 52
DK-3460 BIRKEROD
 Tel: (02) 81-66-40
 Telex: 37409 hpas dk
 A,CH,CM,CS,E,MS,P

Hewlett-Packard A/S
 Navervej 1
DK-8600 SILKEBORG
 Tel: (06) 82-71-66
 Telex: 37409 hpas dk
 CH,CM,E

ECUADOR

CYEDE Cia. Ltda.
Avenida Eloy Alfaro 1749
Casilla 6423 CCI
QUITO
 Tel: 450-975, 243-052
 Telex: 2548 CYEDE ED
 A,CM,E,P

Hospitalar S.A.
Robles 625
Casilla 3590
QUITO
 Tel: 545-250, 545-122
 Telex: 2485 HOSPITL ED
 Cable: HOSPITALAR-Quito
 M

EGYPT

International Engineering Associates
24 Hussein Hegazi Street
Kasr-el-Aini
CAIRO
 Tel: 23-829
 Telex: 93830
 CH,CS,E,M

Informatic For Systems
22 Talaat Harb Street
CAIRO
 Tel: 759006
 Telex: 93938 FRANK UN
 CH,CS,P

Egyptian International Office
for Foreign Trade
P.O.Box 2558
CAIRO
 Tel: 984935
 Telex: 93337 EGPOR
 P

EL SALVADOR

IPESA de El Salvador S.A.
Boulevard de los Heroes 1148
SAN SALVADOR
 Tel: 252787, 259621
 Telex: Public Booth 20107
 A,CH,CM,CS,E,P

FINLAND

Hewlett-Packard Oy
 Revontulentie 7
SF-02100 ESPOO 10
 Tel: (90) 455-0211
 Telex: 121563 hewpa sf
 A,CH,CM,CS,E,MS,P



SALES & SUPPORT OFFICES

Arranged alphabetically by country

FRANCE

Hewlett-Packard France
Le Ligoures
Bureau de Vente de Aix-en-Provence
Place Romée de Villeneuve
F-13090 AIX-EN-PROVENCE
Tel: (42) 59-41-02
Telex: 410770F
A,CH,CM,E,MS,P*

Hewlett-Packard France
Boite Postale No. 503
F-25026 BESANCON
28 Rue de la Republique
F-25000 BESANCON
Tel: (81) 83-16-22
CH,M

Hewlett-Packard France
Bureau de Vente de Lyon
Chemin des Mouilles
Boite Postale No. 162
F-69130 ECULLY Cédex
Tel: (78) 33-81-25
Telex: 310617F
A,CH,CM,CS,E,MP

Hewlett-Packard France
Immeuble France Evry
Tour Lorraine
Boulevard de France
F-91035 EVRY Cédex
Tel: (60) 77-96-60
Telex: 692315F
CM,E

Hewlett-Packard France
5th Avenue Raymond Chanas
F-38320 EYBENS
Tel: (76) 25-81-41
Telex: 980124 HP GRENOS EYBE
CH,CM

Hewlett-Packard France
Bâtiment Ampère
Rue de la Commune de Paris
Boite Postale 300
F-93153 LE BLANC MESNIL
Tel: (01) 865-44-52
Telex: 211032F
CH,CM,CS,E,MS

Hewlett-Packard France
Le Montlesquieu
Avenue du President JF Kennedy
F-33700 MERIGNAC
Tel: (56) 34-00-84
Telex: 550105F
CH,CM,E,MS

Hewlett-Packard France
32 Rue Lothaire
F-57000 METZ
Tel: (87) 65-53-50
CH,CM

Hewlett-Packard France
3 Rue Julien Videment
F-44200 NANTES
Tel: (40) 48-09-44
CH**

Hewlett-Packard France
Zone Industrielle de Courtaboeuf
Avenue des Tropiques F-91947 Les
Ulis Cédex ORSAY
Tel: (1) 907-78-25
Telex: 600048F
A,CH,CM,CS,E,MP,P

Hewlett-Packard France
Paris Porte-Maillot 13, 15 25
Boulevard De L'Amiral Bruix
F-75782 PARIS Cédex 16
Tel: (01) 502-12-20
Telex: 613663F
CH,CM,MS,P

Hewlett-Packard France
2 Allee de la Bourgonette
F-35100 RENNES
Tel: (99) 51-42-44
Telex: 740912F
CH,CM,E,MS,P*

Hewlett-Packard France
98 Avenue de Bretagne
F-76100 ROUEN
Tel: (35) 63-57-66 CH** ,CS

Hewlett-Packard France
4 Rue Thomas Mann
Boite Postale 56
F-67200 STRASBOURG
Tel: (88) 28-56-46
Telex: 890141F
CH,CM,E,MS,P*

Hewlett-Packard France
20 Chemin de la Cèpière
F-31081 TOULOUSE Cédex
Tel: (61) 40-11-12
Telex: 531639F
A,CH,CM,CS,E,P*

Hewlett-Packard France
Bureau de Vente de Lille
Immeuble Péricentre
Rue Van Gogh
F-59650 VILLENEUVE D'ASQ
Tel: (20) 91-41-25
Telex: 160124F
CH,CM,E,MS,P*

GERMAN FEDERAL REPUBLIC

Hewlett-Packard GmbH
Technisches Büro Berlin
Keithstrasse 2-4
D-1000 BERLIN 30
Tel: (030) 24-90-86
Telex: 018 3405 hpbin d
A,CH,CM,E,M,P,X

Hewlett-Packard GmbH
Technisches Büro Böblingen
Herrenberger Strasse 110
D-7030 BÖBLINGEN
Tel: (07031) 667-1
Telex: 07265739 bbn or 07265743
A,CH,CM,CS,E,MP,P

Hewlett-Packard GmbH
Technisches Büro Dusseldorf
Emanuel-Leutze-Strasse 1
D-4000 DUSSELDORF
Tel: (0211) 5971-1
Telex: 085/86 533 hpdd d
A,CH,CM,CS,E,MS,P

Hewlett-Packard GmbH
Vertriebszentrale Frankfurt
Bernier Strasse 117
Postfach 560 140
D-6000 FRANKFURT 56
Tel: (0611) 50-04-1
Telex: 04 13249 hpftm d
A,CH,CM,CS,E,MP,P

Hewlett-Packard GmbH
Technisches Büro Hamburg
Kapstadttring 5
D-2000 HAMBURG 60
Tel: (040) 63804-1
Telex: 21 63 032 hphh d
A,CH,CM,CS,E,MS,P

Hewlett-Packard GmbH
Technisches Büro Hannover
Am Grossmarkt 1
D-3000 HANNOVER 91
Tel: (0511) 46-60-01
Telex: 092 3259
A,CH,CM,E,MS,P

Hewlett-Packard GmbH
Technisches Büro Mannheim
Rosslauer Weg 2-4
D-6800 MANNHEIM
Tel: (621) 70050
Telex: 0462105
A,C,E

Hewlett-Packard GmbH
Technisches Büro Neu Ulm
Messerschmittstrasse 7
D-7910 NEU ULM
Tel: 0731-70241
Telex: 712816 HP ULM-D
A,C,E*

Hewlett-Packard GmbH
Technisches Büro Nürnberg
Neumeyerstrasse 90
D-8500 NÜRNBERG
Tel: (0911) 56-30-83
Telex: 0623 860
CH,CM,E,MS,P

Hewlett-Packard GmbH
Technisches Büro München
Eschensstrasse 5
D-8021 TAUFKIRCHEN
Tel: (089) 6117-1
Telex: 0524985
A,CH,CM,E,MS,P

Hewlett-Packard Ltd.
Trafalgar House
Navigation Road
ALTRINCHAM
Cheshire WA14 1NU
Tel: (061) 928-6422
Telex: 668068
A,CH,CS,E,M

Hewlett-Packard Ltd.
Oakfield House, Oakfield Grove
Clifton
BRISTOL BS8 2BN
Tel: 36806
Telex: 444302
CH,CM,M,P

Hewlett-Packard Ltd.
14 Wesley Street
CASTLEFORD
Yorkshire WF10 1AE
Tel: (0977) 550016
Telex: 5557355
CH

Hewlett-Packard Ltd.
Fourier House
257-263 High Street
LONDON COLNEY
Herts., AL2 1HA
Tel: (0727) 24400
Telex: 1-8952716
CH,CS,E

Hewlett-Packard Ltd
Tradax House, St. Mary's Walk
MAIDENHEAD
Berkshire, SL6 1ST
Tel: (0628) 39151
CH,CS,E,P

Hewlett-Packard Ltd.
308/314 Kings Road
READING, Berkshire
Tel: 61022
Telex: 84-80-68
CM,P

Hewlett-Packard Ltd.
Quadrangle
106-118 Station Road
REDHILL, Surrey
Tel: (0737) 68655
Telex: 947234 CH,CS,E

GREAT BRITAIN

Hewlett-Packard Ltd.
Westminster House
190 Stratford Road
SHIRLEY, Solihull
West Midlands B90 3BJ
Tel: (021) 7458800
Telex: 339105
CH

Hewlett-Packard Ltd.
King Street Lane
WINNERSH, Wokingham
Berkshire RG11 5AR
Tel: (0734) 784774
Telex: 847178
A,CS,E,M

Hewlett-Packard Ltd.
7 Hare Street
CALCUTTA 700 001
Tel: 12-01-31
Telex: 021-7655
Cable: BLUESTAR
A,M

Hewlett-Packard Ltd.
133 Kodambakkam High Road
MADRAS 600 034
Tel: 82057
Telex: 041-379
Cable: BLUESTAR
A,M

Hewlett-Packard Ltd.
Bhandari House, 7th/8th Floors
91 Nehru Place
NEW DELHI 110 024
Tel: 682547
Telex: 031-2463
Cable: BLUESTAR
A,CH,CM,CS,E,M

Hewlett-Packard Ltd.
15/16: C Wellesley Rd.
PUNE 411 011
Tel: 22775
Cable: BLUE STAR
A

Hewlett-Packard Ltd.
1-1-117/1 Sarojini Devi Road
SECUNDERABAD 500 033
Tel: 70126
Telex: 0155-459
Cable: BLUEFROST
A,E

Hewlett-Packard Ltd.
T.C. 7/603 Poornima
Maruthankuzhi
TRIVANDRUM 695 013
Tel: 65799
Telex: 0884-259
Cable: BLUESTAR
E

Hewlett-Packard Ltd.
BERCA Indonesia P.T.
P.O.Box 496/JKT.
Jl. Abdul Muis 62
JAKARTA
Tel: 373009
Telex: 46748 BERSAL IA
Cable: BERSAL JAKARTA
P

Hewlett-Packard Ltd.
Wisma Antara Bldg., 17th floor
JAKARTA
A,CS,E,M

Hewlett-Packard Ltd.
Band Box House
Prabhadevi
BOMBAY 400 025
Tel: 422-3101
Telex: 011-3751
Cable: BLUESTAR
A,M

Hewlett-Packard Ltd.
Westminster House
190 Stratford Road
SHIRLEY, Solihull
West Midlands B90 3BJ
Tel: (021) 7458800
Telex: 339105
CH

Hewlett-Packard Ltd.
King Street Lane
WINNERSH, Wokingham
Berkshire RG11 5AR
Tel: (0734) 784774
Telex: 847178
A,CS,E,M

GREECE

Kostas Karayannis S.A.
8 Omirou Street
ATHENS 133
Tel: 32-30-303, 32-37-371
Telex: 21 59 62 RKAR GR
A,CH,CM,CS,E,M,P

PLAISIO S.A.
G. Gerardos
24 Stournara Street
ATHENS
Tel: 36-11-160
Telex: 21 9492
P

GUATEMALA

IPESA
Avenida Reforma 3-48
GUATEMALA 9
Tel: 316627, 314786
Telex: 4192 TELETRO GU
A,CH,CM,CS,E,M,P

HONG KONG

Hewlett-Packard Hong Kong, Ltd.
G.P.O. Box 795
5th Floor, Sun Hung Kai Centre
30 Harbour Road
HONG KONG
Tel: 5-8323211
Telex: 66678 HEWPA HX
Cable: HP ASIA LTD Hong Kong
E,CH,CS,P

Schmidt & Co. (Hong Kong) Ltd.
Wing On Centre, 28th Floor
Connaught Road, C.
HONG KONG
Tel: 5-455644
Telex: 74766 SCHMX HX
A,M

ICELAND

Elðing Trading Company inc.
Hafnarvölli-Tryggvagötu
P.O. Box 895
IS-REYKJAVIK
Tel: 1-58-20, 1-63-03
M

INDIA

Blue Star Ltd.
11 Magarath Road
BANGALORE 560 025
Tel: 55668
Telex: 0845-430
Cable: BLUESTAR
A,CH,CM,CS,E

Blue Star Ltd.
Band Box House
Prabhadevi
BOMBAY 400 025
Tel: 422-3101
Telex: 011-3751
Cable: BLUESTAR
A,M

Blue Star Ltd.
Sahas
414/2 Vir Savarkar Marg
Prabhadevi
BOMBAY 400 025
Tel: 422-6155
Telex: 011-4093
Cable: FROSTBLUE
A,CH,CM,CS,E,M

Blue Star Ltd.
Kalyan, 19 Vishwas Colony
Alkapuri, BORDA, 390 005
Tel: 65235
Cable: BLUE STAR
A

Blue Star Ltd.
7 Hare Street
CALCUTTA 700 001
Tel: 12-01-31
Telex: 021-7655
Cable: BLUESTAR
A,M

Blue Star Ltd.
133 Kodambakkam High Road
MADRAS 600 034
Tel: 82057
Telex: 041-379
Cable: BLUESTAR
A,M

Blue Star Ltd.
Bhandari House, 7th/8th Floors
91 Nehru Place
NEW DELHI 110 024
Tel: 682547
Telex: 031-2463
Cable: BLUESTAR
A,CH,CM,CS,E,M

Blue Star Ltd.
15/16: C Wellesley Rd.
PUNE 411 011
Tel: 22775
Cable: BLUE STAR
A

Blue Star Ltd.
1-1-117/1 Sarojini Devi Road
SECUNDERABAD 500 033
Tel: 70126
Telex: 0155-459
Cable: BLUEFROST
A,E

Blue Star Ltd.
T.C. 7/603 Poornima
Maruthankuzhi
TRIVANDRUM 695 013
Tel: 65799
Telex: 0884-259
Cable: BLUESTAR
E

INDONESIA

BERCA Indonesia P.T.
P.O.Box 496/JKT.
Jl. Abdul Muis 62
JAKARTA
Tel: 373009
Telex: 46748 BERSAL IA
Cable: BERSAL JAKARTA
P

BERCA Indonesia P.T.
Wisma Antara Bldg., 17th floor
JAKARTA
A,CS,E,M

BERCA Indonesia P.T.
P.O. Box 174/SBY.
Jl. Kutei No. 11
SURABAYA
Tel: 68172
Telex: 31146 BERSAL SB
Cable: BERSAL-SURABAYA
A*,E,M,P

**IRAQ**

Hewlett-Packard Trading S.A.
Mansoor City 9B/3/7
BAGHDAD
Tel: 551-49-73
Telex: 2455 HEPAIRAQ IK
CH,CS

IRELAND

Hewlett-Packard Ireland Ltd.
Kestrel House
Clanwilliam Court
Lower Mount Street
DUBLIN 2, Eire
Tel: 680424, 680426
Telex: 30439
A,CH,CM,CS,E,M,P
Cardiac Services Ltd.
Kilmore Road
Artane
DUBLIN 5, Eire
Tel: (01) 351820
Telex: 30439
M

ISRAEL

Electronics Engineering Division
Motorola Israel Ltd.
16 Kremenetski Street
P.O. Box 25016
TEL-AVIV 67899
Tel: 3-338973
Telex: 33569 Motil IL
Cable: BASTEL Tel-Aviv
A,CH,CM,CS,E,M,P

ITALY

Hewlett-Packard Italiana S.p.A.
Traversa 99C
Giulio Petrone, 19
I-70124 **BARI**
Tel: (080) 41-07-44
M

Hewlett-Packard Italiana S.p.A.
Via Martin Luther King, 38/111
I-40132 **BOLOGNA**
Tel: (051) 402394
Telex: 511630
CH,CM,E,MS

Hewlett-Packard Italiana S.p.A.
Via Principe Nicola 43G/C
I-95126 **CATANIA**
Tel: (095) 37-10-87
Telex: 970291 C,P

Hewlett-Packard Italiana S.p.A.
Via G. Di Vittorio 9
I-20063 **CERNUSCO SUL NAVIGLIO**
Tel: (2) 903691
Telex: 334632
A,CH,CM,CS,E,MP,P

Hewlett-Packard Italiana S.p.A.
Via Nuova san Rocco A
Capodimonte, 62/A
I-80131 **NAPOLI**
Tel: (081) 7413544
A,CH,CM,E

Hewlett-Packard Italiana S.p.A.
Viale G. Modugno 33
I-16156 **GENOVA PEGLI**
Tel: (010) 68-37-07 E,C

Hewlett-Packard Italiana S.p.A.
Via Turazza 14
I-35100 **PADOVA**
Tel: (49) 664888
Telex: 430315
A,CH,CM,E,MS

Hewlett-Packard Italiana S.p.A.
Viale C. Pavese 340
I-00144 **ROMA**
Tel: (06) 54831
Telex: 610514
A,CH,CM,CS,E,MS,P*

Hewlett-Packard Italiana S.p.A.
Corso Giovanni Lanza 94
I-10133 **TORINO**
Tel: (011) 682245, 659308
Telex: 221079
CH,CM,E

JAPAN

Yokogawa-Hewlett-Packard Ltd.
Inoue Building
1-1348-3, Asahi-cho
ATSUGI, Kanagawa 243
Tel: (0462) 24-0451
CM,C*,E

Yokogawa-Hewlett-Packard Ltd.
Sannomiya-Daichi Seimei-Bldg. 5F
69 Kyo-machi Chuo-ku
KOBE 650
Tel: (078) 392-4791
C,E

Yokogawa-Hewlett-Packard Ltd.
Kumagaya Asahi Yasoji Bldg 4F
3-4 Chome Tsukuba
KUMAGAYA, Saitama 360
Tel: (0485) 24-6563
CH,CM,E

Yokogawa-Hewlett-Packard Ltd.
Mito Mitsui Building
1-4-73, San-no-maru
MITO, Ibaragi 310
Tel: (0292) 25-7470
CH,CM,E

Yokogawa-Hewlett-Packard Ltd.
Sumitomo Seimei Nagoya Bldg.
11-2 Shimo-sasajima-cho
Nakamura-ku
NAGOYA, Aichi 450
Tel: (052) 571-5171
CH,CM,CS,E,MS

Yokogawa-Hewlett-Packard Ltd.
Chuo Bldg., 4th Floor
5-4-20 Nishinakajima, 5-chome
Yodogawa-ku
OSAKA, 532
Tel: (06) 304-6021
Telex: YHPOSA 523-3624
A,CH,CM,CS,E,MP,P*

Yokogawa-Hewlett-Packard Ltd.
3-29-21 Takaida-Higashi 3-chome
Suginami-ku
TOKYO 168
Tel: (03) 331-6111
Telex: 232-2024 YHPTOK
A,CH,CM,CS,E,MP,P*

Yokogawa-Hewlett-Packard Ltd.
3-30-4 Tsuruya-cho
Kanagawa-ku,
YOKOHAMA Kanagawa, 221
Tel: (045) 312-1252
CH,CM,E

JORDAN

Mouasher Cousins Company
P.O. Box 1387
AMMAN
Tel: 24907, 39907
Telex: 21456 SABCO JO
CH,E,M,P

KENYA

ADCOM Ltd., Inc.
City House, Wabera Street
P.O. Box 30635
NAIROBI
Tel: 331955
Telex: 22639
E,M

KOREA

Samsung Electronics
Industrial Products Div.
76-561 Yeoksam-Dong
Kangnam-Ku
C.P.O. Box 2775
SEOUL
Tel: 555-7555, 555-5447
Telex: K27364 SAMSAN
A,CH,CM,CS,E,M,P

KUWAIT

Al-Khalidya Trading & Contracting
P.O. Box 830 Safat
KUWAIT
Tel: 42-4910, 41-1726
Telex: 2481 Areeg K1
CH,E,M

Photo & Cine Equipment
P.O. Box 270 Safat
KUWAIT
Tel: 42-2846, 42-3801
Telex: 2247 Malin
P

LEBANON

G.M. Dolmadjian
Achratieh
P.O. Box 165.167
BEIRUT
Tel: 290293
MP

LUXEMBOURG

Hewlett-Packard Belgium S.A./N.V.
Blvd de la Woluwe, 100
Woluwedal
B-1200 **BRUSSELS**
Tel: (02) 762-32-00
Telex: 23-494 paioben bru
A,CH,CM,CS,E,MP,P

MALAYSIA

Hewlett-Packard Sales (Malaysia)
Sdn. Bhd.
Suite 2.21/2.22
Bangunan Angkasa Raya
Jalan Ampang
KUALA LUMPUR
Tel: 483544
Telex: MA31011
A,CH,E,M,P*
Protel Engineering
Lot 319, Satok Road
P.O. Box 1917
Kuching, SARAWAK
Tel: 53544
Telex: MA 70904 PROMAL
Cable: PROTELENG
A,E,M

MALTA

Philip Toledo Ltd.
Natabile Rd.
MRIEHEL
Tel: 447 47, 455 66
Telex: MW.649
P

MEXICO

Hewlett-Packard Mexicana, S.A. de
C.V.
Avenida Periferico Sur No. 6501
Tepepan, Xochimilco
MEXICO CITY 23, D.F.
Tel: (905) 676-4600
Telex: 017-74-507
A,CH,CS,E,MS,P
Hewlett-Packard Mexicana, S.A. de
C.V.
Rio Volga 600
Colonia del Valle
MONTERREY, N.L.
Tel: 78-42-93, 78-42-40, 78-42-41
Telex: 038-410
CH

MOROCCO

Dolbeau
81 rue Karatchi
CASABLANCA
Tel: 3041-82, 3068-38
Telex: 23051, 22822
E

Gerep

2 rue d'Agadir
Boite Postale 156
CASABLANCA
Tel: 272093, 272095
Telex: 23 739
P

NETHERLANDS

Hewlett-Packard Nederland B.V.
Van Heuven Goedhartlaan 121
NL 1181KK AMSTELVEEN
P.O. Box 667
NL 1080 AR AMSTELVEEN
Tel: (20) 47-20-21
Telex: 13 216
A,CH,CM,CS,E,MP,P

Hewlett-Packard Nederland B.V.

Bongerd 2
NL 2906VK CAPPELLE, A/D IJssel
P.O. Box 41
NL 2900 AA CAPELLE, IJssel
Tel: (10) 51-64-44
Telex: 21261 HEPAC NL
A,CH,CM,CS
Koning en Hartman Electrotechniek
B.V.
Koperwerf 30
2544 En den Haag
The **NETHERLANDS**
Tel: 070-210101
Telex: 31528
CM

NEW ZEALAND

Hewlett-Packard (N.Z.) Ltd.
169 Manukau Road
P.O. Box 26-189
Epsom, AUCKLAND
Tel: 687-159
Cable: HEWPACK Auckland
CH,CM,E,P*

Hewlett-Packard (N.Z.) Ltd.
4-12 Cruickshank Street
Kilbirnie, **WELLINGTON 3**
P.O. Box 9443
Courtenay Place, **WELLINGTON**
Tel: 877-199
Cable: HEWPACK Wellington
CH,CM,E,P
Northrop Instruments & Systems
Ltd.
369 Khyber Pass Road
P.O. Box 8602
AUCKLAND
Tel: 794-091
Telex: 60605
A,M

Northrop Instruments & Systems
Ltd.
110 Mandeville St.
P.O. Box 8388
CHRISTCHURCH
Tel: 486-928
Telex: 4203
A,M

Northrop Instruments & Systems
Ltd.
Sturdee House
85-87 Ghuznee Street
P.O. Box 2406
WELLINGTON
Tel: 850-091
Telex: NZ 3380
A,M

NORTHERN IRELAND

Cardiac Services Company
95A Finaghy Road South
BELFAST BT 10 OBY
Tel: (0232) 625-566
Telex: 747626
M

NORWAY

Hewlett-Packard Norge A/S
Folke Bernadottesvei 50
P.O. Box 3558
N-5033 FYLLINGSDALEN (BERGEN)
Tel: (05) 16-55-40
Telex: 16621 hpnas n
CH,CM,E

Hewlett-Packard Norge A/S

Oesterdalen 18
P.O. Box 34
N-1345 OESTERAAS
Tel: (02) 17-11-80
Telex: 16621 hpnas n
A*,CH,CM,E,MS,P

OMAN

Khimji Ramdas
P.O. Box 19
MUSCAT
Tel: 72-22-17, 72-22-25
Telex: 3289 BROKER MB MUSCAT
P

PAKISTAN

Mushko & Company Ltd.
10, Bazar Road
Sector G-6/4
ISLAMABAD
Tel: 26875
Cable: FEMUS Rawalpindi
A,E,M

Mushko & Company Ltd.
Oosman Chambers
Abdullah Haroon Road
KARACHI 0302
Tel: 511027, 512927
Telex: 2894 MUSKO PK
Cable: COOPERATOR Karachi
A,E,M,P*

PANAMA

Electrónico Balboa, S.A.
Calle Samuel Lewis
Apartado 4929
Panama 5
Edificio "Alfa" No. 2
CIUDAD DE PANAMA
Tel: 64-2700
Telex: 0383 ELECTRON PG
A,CM,E,M,P



SALES & SUPPORT OFFICES

Arranged alphabetically by country

PANAMA (Con't.)

Foto Internacional, S.A.
Free Zone Colon
Apartado 2068
COLON 3
Tel: 45-2333
Telex: 379 8626, 386 8722
P

PERU

Cia Electro Médica S.A.
Los Flamencos 145, San Isidro
Casilla 1030
LIMA 1
Tel: 41-4325, 41-3703
Telex: Pub. Booth 25306
A,CM,E,M,P

PHILIPPINES

The Online Advanced Systems
Corporation
Rico House, Amorsolo Cor. Herrera
Street
Legaspi Village, Makati
P.O. Box 1510
Metro MANILA
Tel: 85-35-81, 85-34-91, 85-32-21
Telex: 3274 ONLINE
A,CH,CS,E,M
Electronic Specialists and
Proponents Inc.
690-B Epifanio de los Santos
Avenue
Cubao, QUEZON CITY
P.O. Box 2649 Manila
Tel: 98-96-81, 98-96-82, 98-96-83
Telex: 40018, 42000 ITT GLOBE
MACKAY BOOTH
P

POLAND

Buro Informacji Technicznej
Hewlett-Packard
Ul. Slawki 2, 6P
PL00-950 WARSZAWA
Tel: 39-59-62, 39-67-43
Telex: 812453 hepa pl

PORTUGAL

SOQUIMICA
Av. da Liberdade 220-2
P-1298 LISBOA Codex
Tel: 56 21 81, 56 21 82
Telex: 13316
Telectra-Empresa Técnica de
Equipamentos Eléctricos S.a.r.l.
Rua Rodrigo da Fonseca 103
P.O. Box 2531
P-LISBON 1
Tel: (19) 68-60-72
Telex: 12598
CH,CS,E,P
Mundinter
Intercambio Mundial de Comércio
S.a.r.l.
P.O. Box 2761
Avenida Antonio Augusto de Aguiar
138
P-LISBON
Tel: (19) 53-21-31, 53-21-37
Telex: 16691 munter p
M

PUERTO RICO

Hewlett-Packard Puerto Rico
P.O. Box 4407
CAROLINA, Puerto Rico 00630
Calle 272 Edificio 203
Urb. Country Club
RIO PIEDRAS, Puerto Rico 00924
Tel: (809) 762-7255
Telex: 345 0514
A,CH,CS

QATAR

Nasser Trading & Contracting
P.O. Box 1563
DOHA
Tel: 22170
Telex: 4439 NASSER
M

Computearabia
P.O. Box 2570
DOHA
Tel: 329515
Telex: 4806 CHPARB
P

ROMANIA

Hewlett-Packard Reprezentanta
Boulevard Nicolae Balcescu 16
BUCURESTI
Tel: 130725
Telex: 10440

SAUDI ARABIA

Modern Electronic Establishment
P.O. Box 193
AL-KHOBAR
Tel: 44-678, 44-813
Telex: 670136
Cable: ELECTA AL-KHOBAR
CH,CS,E,M,P
Modern Electronic Establishment
P.O. Box 1228, Baghdadiah Street
JEDDAH
Tel: 27-798
Telex: 401035
Cable: ELECTA JEDDAH
CH,CS,E,M,P
Modern Electronic Establishment
P.O. Box 2728
RIYADH
Tel: 62-596, 66-232
Telex: 202049
CH,CS,E,M,P

SCOTLAND

Hewlett-Packard Ltd.
Royal Bank Buildings
Swan Street
BRECHIN, Angus, Scotland
Tel: 3101, 3102
CH,CM
Hewlett-Packard Ltd.
SOUTH QUEENSFERRY
West Lothian, EH30 9GT
GB-Scotland
Tel: (031) 3311000
Telex: 72682
A,CH,CM,CS,E,M

SINGAPORE

Hewlett-Packard Singapore (Pty.)
Ltd.
P.O. Box 58 Alexandra Post Office
SINGAPORE, 9115
6th Floor, Inchcape House
450-452 Alexandra Road
SINGAPORE 0511
Tel: 631788
Telex: HPGSSO RS 34209
Cable: HEWPACK, Singapore
A,CH,CS,E,MS,P

SOUTH AFRICA

Hewlett-Packard South Africa (Pty.)
Ltd.
P.O. Box 120
Howard Place
Pine Park Center, Forest Drive,
Pinelands
CAPE PROVINCE 7450
Tel: 53-7955, 53-7956, 53-7957
Telex: 57-0006
A,CH,CM,E,MS,P

Hewlett-Packard South Africa (Pty.)
Ltd.
P.O. Box 37099
Overport
DURBAN 4067
Tel: 28-4178, 28-4179, 28-4110
CH,CM

Hewlett-Packard South Africa (Pty.)
Ltd.
P.O. Box 33345
Glenstantia 0010 TRANSVAAL
1st Floor East
Constantia Park Ridge Shopping
Centre
Constantia Park
PRETORIA
Tel: 01298-1126
Telex: 32163
CH,E

Hewlett-Packard South Africa (Pty.)
Ltd.
Private Bag Wendywood
SANDTON 2144
Tel: 802-5111, 802-5125
Telex: 89-84782
Cable: HEWPACK Johannesburg
A,CH,CM,CS,E,MS,P

SPAIN

Hewlett-Packard Española S.A.
c/Entenza, 321
E-BARCELONA 29
Tel: (3) 322-24-51, 321-73-54
Telex: 52603 hpbee
A,CH,CM,CS,E,MS,P
Hewlett-Packard Española S.A.
c/San Vicente S/N
Edificio Albia II, 7 B
E-BILBAO 1
Tel: (944) 423-8306, 423-8206
A,CH,CM,E,MS
Hewlett-Packard Española S.A.
Calle Jerez 3
E-MADRID 16
Tel: 458-2600
Telex: 23515 hpe
A,CM,E
Hewlett-Packard Española S.A.
c/o Costa Brava 13
Colonia Mirasierra
E-MADRID 34
Tel: 734-8061, 734-1162
CH,CS,M

Hewlett-Packard Española S.A.
Av Ramón y Cajal 1-9
Edificio Sevilla 1,
E-SEVILLA 5
Tel: 64-44-54, 64-44-58
Telex: 72933
A,CM,CS,MS,P
Hewlett-Packard Española S.A.
C/Ramon Gordillo, 1 (Entlo.3)
E-VALENCIA 10
Tel: 361-1354, 361-1358
CH,CM,P

SWEDEN

Hewlett-Packard Sverige AB
Enighetsvägen 3, Fack
P.O. Box 20502
S-16120 BROMMA
Tel: (08) 730-0550
Telex: (854) 10721 MESSAGES
Cable: MEASUREMENTS
STOCKHOLM
A,CH,CM,CS,E,MS,P

Hewlett-Packard Sverige AB
Sunnavägen 14K
S-22226 LUND
Tel: (46) 13-69-79
Telex: (854) 10721 (via BROMMA
office)
CH,CM

Hewlett-Packard Sverige AB
Vastra Vintergatan 9
S-70344 ÖREBRO
Tel: (19) 10-48-80
Telex: (854) 10721 (via BROMMA
office)
CH,CM

Hewlett-Packard Sverige AB
Frötällsgatan 30
S-42132 VÄSTRA-FRÖLUNDA
Tel: (031) 49-09-50
Telex: (854) 10721 (via BROMMA
office)
CH,CM,E,P

SWITZERLAND

Hewlett-Packard (Schweiz) AG
Clarastrasse 12
CH-4058 BASEL
Tel: (61) 33-59-20
A,CM

Hewlett-Packard (Schweiz) AG
Bahnhofstrasse 44
CH-1015 BERN
Tel: (031) 56-24-22
CH,CM

Hewlett-Packard (Schweiz) AG
47 Avenue Blanc
CH-1202 GENEVA
Tel: (022) 32-30-05, 32-48-00
CH,CM,CS

Hewlett-Packard (Schweiz) AG
29 Chemin Château Bioc
CH-1219 LE LIGNON-Geneva
Tel: (022) 96-03-22
Telex: 27333 hpag ch
Cable: HEWPACKAG Geneva
A,CM,E,MS,P

Hewlett-Packard (Schweiz) AG
Zürcherstrasse 20
Allmend 2
CH-8967 WIDEN
Tel: (022) 50-1111
Telex: 59933 hpag ch
Cable: HPAG CH
A,CH,CM,CS,E,MS,P

SYRIA

General Electronic Inc.
Nuri Basha-Ahmad Ebn Kays Street
P.O. Box 5781

DAMASCUS
Tel: 33-24-87
Telex: 11215 ITIKAL
Cable: ELECTROBOR DAMASCUS
E

Middle East Electronics
Place Azmé

Boite Postale 2308
DAMASCUS
Tel: 334592
Telex: 11304 SATACO SY
M,P

TAIWAN

Hewlett-Packard Far East Ltd.
Kaohsiung Office
2/F 68-2, Chung Cheng 3rd Road
KAOHSIUNG
Tel: 241-2318, 261-3253
E,MS,P

Hewlett-Packard Far East Ltd.
Taichung Office
#33, Cheng Tr Rd.
10th Floor, Room 5
TAICHUNG
Tel: (042) 289274

Hewlett-Packard Far East Ltd.
Taiwan Office
5th Floor
205 Tun Hwa North Road
TAIPEI
Tel: (02) 751-0404
Cable: HEWPACK Taipei
A,CH,CS,E,MS,P

Ing Lih Trading Co.
3rd Floor 18, Po-Ai Road
TAIPEI (100)
Tel: (02) 311-1914
Cable: INGLIH TAIPEI
A

THAILAND

Unimesa
30 Patpong Ave., Sunwong
BANGKOK 5
Tel: (234-091) (234-092)
Telex: TH 81160, TH 81038
Cable: UNIMESA Bangkok
A,C,E,M
Bangkok Business Equipment Ltd.
5/5-6 Dejo Road
BANGKOK
Tel: 234-8670, 234-8671
Telex: 87669-BEQUIPT TH
Cable: BUSIQUIPT Bangkok
P

TRINIDAD & TOBAGO

Caribbean Telecoms Ltd.
50/A Jerningham Avenue
P.O. Box 732
PORT-OF-SPAIN
Tel: 624-4213, 624-4214
Telex: 3235, 3272 HUGCO WG
A,CM,E,M,P

TUNISIA

Tunisie Electronique
31 Avenue de la Liberté
TUNIS
Tel: 280-144
E,P
Corema
1 ter. Av. de Carthage
TUNIS
Tel: 253-821
Telex: 12319 CABAM TN
M

TURKEY

Teknim Company Ltd.
Iran Caddesi No. 7
Kavaklidere, ANKARA
Tel: 275800
Telex: 42155
E
E.M.A.
Medina Eldem Sokak No.41/6
Yukseki Caddesi
ANKARA
Tel: 175 622
M,P

UNITED ARAB EMIRATES

Emilat Ltd.
P.O. Box 1641
SHARJAH
Tel: 354121, 354123
Telex: 68136 Emilat SL
CH,CS,E,M,P



UNITED KINGDOM
see: GREAT BRITAIN
NORTHERN IRELAND
SCOTLAND

UNITED STATES

Alabama

Hewlett-Packard Co.
 700 Century Park South
 Suite 128
 BIRMINGHAM, AL 35226
 Tel: (205) 822-6802
 CH,CM,MP
 Hewlett-Packard Co.
 P.O. Box 4207
 8290 Whitesburg Drive, S.E.
 HUNTSVILLE, AL 35802
 Tel: (205) 881-4591
 CH,CM,CS,E,M*

Alaska

Hewlett-Packard Co.
 1577 "C" Street, Suite 252
 ANCHORAGE, AK 99510
 Tel: (206) 454-3971
 CH*,CM

Arizona

Hewlett-Packard Co.
 2336 East Magnolia Street
 PHOENIX, AZ 85034
 Tel: (602) 273-8000
 A,CH,CM,CS,E,MS
 Hewlett-Packard Co.
 2424 East Aragon Road
 TUCSON, AZ 85702
 Tel: (602) 889-4631
 CH,CM,E,MS**

Arkansas

Hewlett-Packard Co.
 P.O. Box 5646
 Brady Station
 LITTLE ROCK, AR 72215
 Tel: (501) 376-1844, (501) 664-8773
 CM,MS

California

Hewlett-Packard Co.
 99 South Hill Dr.
 BRISBANE, CA 94005
 Tel: (415) 330-2500
 CH,CM,CS
 Hewlett-Packard Co.
 7621 Canoga Avenue
 CANOGA PARK, CA 91304
 Tel: (213) 702-8300
 A,CH,CM,CS,E,P
 Hewlett-Packard Co.
 1579 W. Shaw Avenue
 FRESNO, CA 93771
 Tel: (209) 224-0582
 CM,MS
 Hewlett-Packard Co.
 1430 East Orangethorpe
 FULLERTON, CA 92631
 Tel: (714) 870-1000
 CH,CM,CS,E,MP
 Hewlett-Packard Co.
 5400 W. Rosecrans Boulevard
 LAWDALE, CA 90260
 P.O. Box 92105
 LOS ANGELES, CA 90009
 Tel: (213) 970-7500
 CH,CM,CS,MP
 Hewlett-Packard Co.
 3939 Lankershim Blvd.
 NORTH HOLLYWOOD, CA 91604
 Tel: (213) 877-1282
 Regional Headquarters

Hewlett-Packard Co.
 3200 Hillview Avenue
 PALO ALTO, CA 94304
 Tel: (415) 857-8000
 CH,CM,CS,E

Hewlett-Packard Co.
 646 W. North Market Boulevard
 SACRAMENTO, CA 95834
 Tel: (916) 929-7222
 A*,CH,CM,CS,E,MS
 Hewlett-Packard Co.
 9606 Aero Drive
 P.O. Box 23333 SAN DIEGO, CA
 92123

Tel: (714) 279-3200
 CH,CM,CS,E,MP
 Hewlett-Packard Co.
 Suite A
 5553 Hollister
 SANTA BARBARA, CA 93111
 Tel: (805) 964-3390

Hewlett-Packard Co.
 3003 Scott Boulevard
 SANTA CLARA, CA 95050
 Tel: (408) 988-7000
 A,CH,CM,CS,E,MP

Colorado

Hewlett-Packard Co.
 24 Inverness Place, East
 ENGLEWOOD, CO 80112
 Tel: (303) 771-3455
 A,CH,CM,CS,E,MS

Connecticut

Hewlett-Packard Co.
 47 Barnes Industrial Road South
 P.O. Box 5007
 WALLINGFORD, CT 06492
 Tel: (203) 265-7801
 A,CH,CM,CS,E,MS

Florida

Hewlett-Packard Co.
 P.O. Box 24210
 2727 N.W. 62nd Street
 FORT LAUDERDALE, FL 33309
 Tel: (305) 973-2600
 CH,CM,CS,E,MP

Hewlett-Packard Co.
 4080 Woodcock Drive, #132
 Brownell Building
 JACKSONVILLE, FL 32207
 Tel: (904) 398-0663
 CM,C*,E*,MS**

Hewlett-Packard Co.
 P.O. Box 13910
 6177 Lake Ellenor Drive
 ORLANDO, FL 32809
 Tel: (305) 859-2900
 A,CH,CM,CS,E,MS

Hewlett-Packard Co.
 6425 N. Pensacola Blvd.
 Suite 4, Building 1
 PENSACOLA, FL 32575
 Tel: (904) 476-8422
 A,CM,MS

Hewlett-Packard Co.
 110 South Hoover, Suite 120
 Vanguard Bldg.
 TAMPA, FL 33609
 Tel: (813) 872-0900
 A*,CH,CM,CS,E*,M*

Georgia

Hewlett-Packard Co.
 P.O. Box 105005
 2000 South Park Place
 ATLANTA, GA 30339
 Tel: (404) 955-1500
 Telex: 810-766-4890
 A,CH,CM,CS,E,MP

Hewlett-Packard Co.
 Executive Park Suite 306
 P.O. Box 816
 AUGUSTA, GA 30907
 Tel: (404) 736-0592
 CM,MS

Hewlett-Packard Co.
 P.O. Box 2103
 1172 N. Davis Drive
 WARNER ROBINS, GA 31098
 Tel: (912) 923-8831
 CM,E

Hawaii

Hewlett-Packard Co.
 Kawaiahao Plaza, Suite 190
 567 South King Street
 HONOLULU, HI 96813
 Tel: (808) 526-1555
 A,CH,CM,E,MS

Idaho

Hewlett-Packard Co.
 11311 Chinden Boulevard
 BOISE, ID 83707
 Tel: (208) 376-6000
 CH,CM,M*

Illinois

Hewlett-Packard Co.
 211 Prospect Road
 BLOOMINGTON, IL 61701
 Tel: (309) 663-0383
 CH,CM,MS**

Hewlett-Packard Co.
 1100 31st Street
 DOWNERS GROVE, IL 60515
 Tel: (312) 960-5760
 CH,CM,CS

Hewlett-Packard Co.
 5201 Tollview Drive
 ROLLING MEADOWS, IL 60008
 Tel: (312) 255-9800
 A,CH,CM,CS,E,MP

Indiana

Hewlett-Packard Co.
 P.O. Box 50807
 7301 No. Shadeland Avenue
 INDIANAPOLIS, IN 46250
 Tel: (317) 842-1000
 A,CH,CM,CS,E,MS

Iowa

Hewlett-Packard Co.
 5815 S.W. 5th Street
 DES MOINES, IA 50315
 Tel: (515) 243-5876
 CH,CM,MS**

Hewlett-Packard Co.
 2415 Heinz Road
 IOWA CITY, IA 52240
 Tel: (319) 351-1020
 CH,CM,E*,MS

Kansas

Hewlett-Packard Co.
 1644 S. Rock
 WICHITA, KA 67207
 Tel: (316) 265-5200
 CH,CM

Kentucky

Hewlett-Packard Co.
 10170 Linn Station Road
 Suite 525
 LOUISVILLE, KY 40223
 Tel: (502) 426-0100
 A,CH,CM,CS,MS

Louisiana

Hewlett-Packard Co.
 P.O. Box 1449
 3229 Williams Boulevard
 KENNER, LA 70062
 Tel: (504) 443-6201
 A,CH,CM,CS,E,MS

Maryland

Hewlett-Packard Co.
 7121 Standard Drive
 HANOVER, MD 21076
 Tel: (301) 796-7700
 A,CH,CM,CS,E,MS

Hewlett-Packard Co.
 2 Choke Cherry Road
 ROCKVILLE, MD 20850
 Tel: (301) 948-6370
 Telex: 710-828-9685
 A,CH,CM,CS,E,MP

Massachusetts

Hewlett-Packard Co.
 32 Hartwell Avenue
 LEXINGTON, MA 02173
 Tel: (617) 861-8960
 A,CH,CM,CS,E,MP

Michigan

Hewlett-Packard Co.
 23855 Research Drive
 FARMINGTON HILLS, MI 48024
 Tel: (313) 476-6400
 A,CH,CM,CS,E,MP

Hewlett-Packard Co.
 4326 Cascade Road S.E.
 GRAND RAPIDS, MI 49506
 Tel: (616) 957-1970
 CH,CM,CS,MS

Minnesota

Hewlett-Packard Co.
 2025 W. Larpenteur Ave.
 ST. PAUL, MN 55113
 Tel: (612) 644-1100
 A,CH,CM,CS,E,MP

Mississippi

Hewlett-Packard Co.
 P.O. Box 5028
 322 N. Mart Plaza
 JACKSON, MS 39216
 Tel: (601) 982-9363
 CM,MS

Missouri

Hewlett-Packard Co.
 11131 Colorado Avenue
 KANSAS CITY, MO 64137
 Tel: (816) 763-8000
 Telex: 910-771-2087
 A,CH,CM,CS,E,MS

Hewlett-Packard Co.
 1024 Executive Parkway
 ST. LOUIS, MO 63141
 Tel: (314) 878-0200
 A,CH,CM,CS,E,MP

Nebraska

Hewlett-Packard
 7101 Mercy Road
 Suite 101, IBX Building
 OMAHA, NE 68106
 Tel: (402) 392-0948
 CM,MS

Nevada

Hewlett-Packard Co.
 Suite D-130
 5030 Paradise Blvd.
 LAS VEGAS, NV 89119
 Tel: (702) 736-6610
 CM,MS**

New Jersey

Hewlett-Packard Co.
 Crystal Brook Professional Building
 Route 35
 EATONTOWN, NJ 07724
 Tel: (201) 542-1384
 A*,CM,C*,E*,P*
 Hewlett-Packard Co.
 W120 Century Road
 PARAMUS, NJ 07652
 Tel: (201) 265-5000
 A,CH,CM,CS,E,MP

Hewlett-Packard Co.
 60 New England Av. West
 PISCATAWAY, NJ 08854
 Tel: (201) 981-1199
 A,CH,CM,CS,E

New Mexico

Hewlett-Packard Co.
 P.O. Box 11634
 11300 Lomas Blvd., N.E.
 ALBUQUERQUE, NM 87123
 Tel: (505) 292-1330
 Telex: 910-989-1185
 CH,CM,CS,E,MS

New York

Hewlett-Packard Co.
 5 Computer Drive South
 ALBANY, NY 12205
 Tel: (518) 458-1550
 Telex: 710-444-4691
 A,CH,CM,E,MS
 Hewlett-Packard Co.
 9600 Main Street
 CLARENCE, NY 14031
 Tel: (716) 759-8621
 Telex: 710-523-1893
 CH

Hewlett-Packard Co.
 200 Cross Keys Office
 FAIRPORT, NY 14450
 Tel: (716) 223-9950
 Telex: 510-253-0092
 CH,CM,CS,E,MS

Hewlett-Packard Co.
 No. 1 Pennsylvania Plaza
 55th Floor
 34th Street & 8th Avenue
 NEW YORK, NY 10119
 Tel: (212) 971-0800
 CH,CM,CS,E*,M*
 Hewlett-Packard Co.
 5858 East Molloy Road
 SYRACUSE NY 13211
 Tel: (315) 455-2486
 A,CH,CM,E,MS

Hewlett-Packard Co.
 3 Crossways Park West
 WOODBURY, NY 11797
 Tel: (516) 921-0300
 Telex: 510-221-2183
 A,CH,CM,CS,E,MS

North Carolina

Hewlett-Packard Co.
 P.O. Box 15579
 2905 Guess Road (27705)
 DURHAM, NC 27704
 Tel: (919) 471-8466
 C,M

Hewlett-Packard Co.
 5605 Roanne Way
 GREENSBORO, NC 27409
 Tel: (919) 852-1800
 A,CH,CM,CS,E,MS

Ohio

Hewlett-Packard Co.
 9920 Carver Road
 CINCINNATI, OH 45242
 Tel: (513) 891-9870
 CH,CM,CS,MS

Hewlett-Packard Co.
 16500 Sprague Road
 CLEVELAND, OH 44130
 Tel: (216) 243-7300
 Telex: 810-423-9430
 A,CH,CM,CS,E,MS

Hewlett-Packard Co.
 962 Crupper Ave.
 COLUMBUS, OH 43229
 Tel: (614) 436-1041
 CH,CM,CS,E*



SALES & SUPPORT OFFICES

Arranged alphabetically by country

Ohio (Con't)

Hewlett-Packard Co.
330 Progress Rd.
DAYTON, OH 45449
Tel: (513) 859-8202
A,CH,CM,E*,MS

Oklahoma

Hewlett-Packard Co.
P.O. Box 366
1503 W. Gore Blvd., Suite #2
LAWTON, OK 73502
Tel: (405) 248-4248
C

Hewlett-Packard Co.
P.O. Box 32008
304 N. Meridian Avenue, Suite A
OKLAHOMA CITY, OK 73107
Tel: (405) 946-9499
A*,CH,CM,E*,MS

Hewlett-Packard Co.
Suite 121
9920 E. 42nd Street
TULSA, OK 74145
Tel: (918) 665-3300
A**,CH,CM,CS,M*

Hewlett-Packard Co.
Suite 121
9920 E. 42nd Street
TULSA, OK 74145
Tel: (918) 665-3300
A**,CH,CM,CS,M*

Oregon

Hewlett-Packard Co.
1500 Valley River Drive, Suite 330
EUGENE, OR 97401
Tel: (503) 683-8075
C

Hewlett-Packard Co.
9255 S. W. Pioneer Court
WILSONVILLE, OR 97070
Tel: (503) 682-8000
A,CH,CM,CS,E*,MS

Pennsylvania

Hewlett-Packard Co.
1021 8th Avenue
King of Prussia Industrial Park
KING OF PRUSSIA, PA 19406
Tel: (215) 265-7000
Telex: 510-660-2670
A,CH,CM,CS,E,MP

Hewlett-Packard Co.
111 Zeta Drive
PITTSBURGH, PA 15238
Tel: (412) 782-0400
A,CH,CM,CS,E,MP

Hewlett-Packard Co.
111 Zeta Drive
PITTSBURGH, PA 15238
Tel: (412) 782-0400
A,CH,CM,CS,E,MP

South Carolina

Hewlett-Packard Co.
P.O. Box 6442
6941-0 N. Trenholm Road
COLUMBIA, SC 29260
Tel: (803) 782-6493
CH,CM,E,MS

Hewlett-Packard Co.
814 Wade Hampton Blvd.
Suite 10
GREENVILLE, SC 29609
Tel: (803) 232-0917
C

Tennessee

Hewlett-Packard Co.
P.O. Box 22490
224 Peters Road
Suite 102
KNOXVILLE, TN 37922
Tel: (615) 691-2371
A*,CH,CM,MS

Hewlett-Packard Co.
3070 Directors Row
MEMPHIS, TN 38131
Tel: (901) 346-8370
A,CH,CM,MS

Hewlett-Packard Co.
Suite 103
478 Craighead Street
NASHVILLE, TN 37204
Tel: (615) 383-9136
CM,MS**

Texas

Hewlett-Packard Co.
Suite 310W
7800 Shoal creek Blvd.
AUSTIN, TX 78757
Tel: (512) 459-3143
CME

Hewlett-Packard Co.
Suite C-110
4171 North Mesa
EL PASO, TX 79902
Tel: (915) 533-3555
CH,CM,E*,MS**

Hewlett-Packard Co.
5020 Mark IV Parkway
FORT WORTH, TX 76106
Tel: (817) 625-6361
CM,C*

Hewlett-Packard Co.
P.O. Box 42816
10535 Harwin Street
HOUSTON, TX 77036
Tel: (713) 776-6400
A,CH,CM,CS,E,MP

Hewlett-Packard Co.
3309 67th Street
Suite 24
LUBBOCK, TX 79413
Tel: (806) 799-4472
M

Hewlett-Packard Co.
P.O. Box 1270
930 E. Campbell Rd.
RICHARDSON, TX 75081
Tel: (214) 231-6101
A,CH,CM,CS,E,MP

Hewlett-Packard Co.
205 Billy Mitchell Road
SAN ANTONIO, TX 78226
Tel: (512) 434-8241
CH,CM,CS,E,MS

Utah

Hewlett-Packard Co.
3530 W. 2100 South Street
SALT LAKE CITY, UT 84119
Tel: (801) 974-1700
A,CH,CM,CS,E,MS

Virginia

Hewlett-Packard Co.
P.O. Box 9669
2914 Hungary Spring Road
RICHMOND, VA 23228
Tel: (804) 285-3431
A,CH,CM,CS,E,MS

Hewlett-Packard Co.
P.O. Box 4786
3110 Peters Creek Road, N.W.
ROANOKE, VA 24015
Tel: (703) 563-2205
CH,CM,E**

Hewlett-Packard Co.
P.O. Box 12778
5700 Thurston Avenue
Suite 111
VIRGINIA BEACH, VA 23455
Tel: (804) 460-2471
CH,CM,MS

Washington

Hewlett-Packard Co.
15815 S.E. 37th Street
BELLEVUE, WA 98006
Tel: (206) 643-4000
A,CH,CM,CS,E,MP

Hewlett-Packard Co.
Suite A
708 North Argonne Road
SPOKANE, WA 99206
Tel: (509) 922-7000
CH,CM,CS

West Virginia

Hewlett-Packard Co.
4604 MacCorkle Ave., S.E.
CHARLESTON, WV 25304
Tel: (304) 925-0492
A,CM,MS

Wisconsin

Hewlett-Packard Co.
150 S. Sunny Slope Road
BROOKFIELD, WI 53005
Tel: (414) 784-8800
A,CH,CM,CS,E*,MP

URUGUAY

Pablo Ferrando S.A.C. e.l.
Avenida Italia 2877
Casilla de Correo 370
MONTEVIDEO
Tel: 80-2586
Telex: Public Booth 901
A,CM,E,M

Guillermo Kraft del Uruguay S.A.
Av. Lib. Brig. Gral. Lavalleja 2083
MONTEVIDEO
Tel: 234588, 234808, 208830
Telex: 6245 ACTOUR UY
P

U.S.S.R.

Hewlett-Packard Co.
Representative Office
Pokrovsky Blvd. 4/17 KV 12
MOSCOW 101000 Tel: 294-2024
Telex: 7825 HEWPACK SU

VENEZUELA

Hewlett-Packard de Venezuela C.A.
Apartado 50933
3A Transversal Los Ruices Norte
Edificio Segre
CARACAS 1071
Tel: 239-4133
Telex: 25146 HEWPACK
A,CH,CS,E,MS,P

YUGOSLAVIA

Iskra-Commerce-Representation of
Hewlett-Packard
Sava Centar Delegacija 30
Milentija Popovica 9
11170 BEOGRAD
Tel: 638-762
Telex: 12042, 12322 YU SAV CEN
Iskra-Commerce-Representation of
Hewlett-Packard
Kopraska 46
61000 LJUBLJANA
Tel: 321674, 315879
Telex:

ZAIRE

Computer & Industrial Engineering
25 Avenue de la Justice
B.P. 10-976
Kinshasa I/Zaire
GOMBE
Tel: 32063
Telex: 21-457 SGEKIN ZR
CH,CS

ZIMBABWE

Field Technical Sales
45 Kelvin Road, North
P.B. 3458
SALISBURY
Tel: 705 231
Telex: 4-122 RH
C,E,M,P

FOR COUNTRIES AND AREAS NOT LISTED:

CANADA

Ontario
Hewlett-Packard (Canada) Ltd.
6877 Goreway Drive
MISSISSAUGA, Ontario L4V 1M8
Tel: (416) 678-9430
Telex: 610-492-4246

EASTERN USA

Maryland

Hewlett-Packard Co.
4 Choke Cherry Road
Rockville, MD 20850
Tel: (301) 258-2000

MIDWESTERN USA

Illinois

Hewlett-Packard Co.
5201 Tollview Drive
ROLLING MEADOWS, IL 60008
Tel: (312) 255-9800

SOUTHERN USA

Georgia

Hewlett-Packard Co.
P.O. Box 105005
450 Interstate N. Parkway
ATLANTA, GA 30339
Tel: (404) 955-1500

WESTERN USA

California

Hewlett-Packard Co.
3939 Lankersim Blvd.
LOS ANGELES, CA 91604
Tel: (213) 877-1282

EUROPEAN AREAS NOT LISTED, CONTACT

SWITZERLAND

Hewlett-Packard S.A.
7 Rue du Bois-du-Lan
CH-1217 MEYRIN 2, Switzerland
Tel: (022) 83-81-11
Telex: 27835 hpse
Cable: HEWPACKSA Geneve

EAST EUROPEAN AREAS NOT LISTED, CONTACT

AUSTRIA

Hewlett-Packard Ges.m.b.H.
Wehlstrasse 29
P.O. Box 7
A-1205 VIENNA
Tel: (222) 35-16-210
Telex: 135823/135066

MEDITERRANEAN AND MIDDLE EAST AREAS NOT LISTED, CONTACT

GREECE

Hewlett-Packard S.A.
Mediterranean & Middle East
Operations
32 Kifissias Ave.
Atrina Center
PARADISOS, Amaroussion
Tel: 808-1741-4
Telex: 21-6588 HPAT GR
Cable: HEWPACKSA Athens

INTERNATIONAL AREAS NOT LISTED, CONTACT

OTHER AREAS

Hewlett-Packard Co.
Intercontinental Headquarters
3495 Deer Creek Road
PALO ALTO, CA 94304
Tel: (415) 857-1501
Telex: 034-8300
Cable: HEWPACK

FOR COUNTRIES AND AREAS NOT LISTED, CONTACT:

AFRICA

NORTHERN AND CENTRAL AFRICA

SWITZERLAND

Hewlett-Packard S.A.
7 Rue du Bois-du-Lan
CH-1217 MEYRIN 2, Switzerland
Tel: (022) 98-96-51
Telex: 27835 hpse
Cable: HEWPACKSA Geneve

ASIA

HONG KONG

Hewlett-Packard Asia Ltd.
6th Floor, Sun Hung Kai Center
30 Harbor Rd.
G.P.O. Box 795
HONG KONG
Tel: 5-832 3211
Telex: 66678 HEWPA HX
Cable: HP ASIA LTD Hong Kong

EUROPE

EASTERN EUROPE

AUSTRIA

Hewlett-Packard Ges.m.b.H.
Wehlstrasse 29
P.O.Box 7
A-1205 VIENNA
Tel: (222) 35-16-210
Telex: 135823/135066

NORTHERN EUROPE

THE NETHERLANDS

Hewlett-Packard S.A.
Uilenstede 475
NL-1183 AG AMSTELVEEN, The Netherlands
P.O.Box 999
NL-1180 AZ AMSTELVEEN, The Netherlands
Tel: 20 437771

SOUTH EASTERN EUROPE

SWITZERLAND

Hewlett-Packard S.A.
7 Rue du Bois-du-Lan
CH-1217 MEYRIN 2, Switzerland
Tel: (022) 98-96-51
Telex: 27835 hpse
Cable: HEWPACKSA Geneve
(Offices in the World Trade Center)

MEDITERRANEAN AND MIDDLE EAST

GREECE

Hewlett-Packard S.A.
Mediterranean and Middle East
Operations
Atrina Centre
32 Kifissias Ave.
Amaroussion, ATHENS, Greece
Tel: 808-0359 808-0429
Telex: 21-6588
Cable: HEWPACKSA Athens

OTHER INTERNATIONAL AREAS

Hewlett-Packard Co.
Intercontinental Headquarters
3495 Deer Creek Road
PALO ALTO, CA 94304
Tel: (415) 857-1501
Telex: 034-8300
Cable: HEWPACK
August 1981 5952-6900