

HP 3563A Operating Manual

Control Systems Analyzer

Volume II

(Includes Data Operations, Appendices, and Installation Guide)



HP Part No. 03563-90000
Microfiche No. 03563-90200

Printed in U.S.A.

Print Date: February 1990

©Hewlett-Packard Company, 1989, 1990. All rights reserved.
8600 Soper Hill Road
Everett, Washington 98205-1298 U.S.A.



CERTIFICATION

Hewlett-Packard Company certifies that this product met its published specifications at the time of shipment from the factory. Hewlett-Packard further certifies that its calibration measurements are traceable to the United States National Bureau of Standards, to the extent allowed by the Bureau's calibration facility, and the calibration facilities of other International Standards Organization Members.

WARRANTY

This Hewlett-Packard product is warranted against defects in material and workmanship for a period of one year from date of shipment. During the warranty period, Hewlett-Packard Company will, at its option, either repair or replace products which prove to be defective. For warranty service or repair, this product must be returned to a service facility designated by HP. Buyer shall prepay shipping charges to -hp- and -hp- shall pay shipping charges to return the product to Buyer. However, Buyer shall pay all shipping charges, duties, and taxes for products returned to -hp- from another country.

HP software and firmware products which are designated by HP for use with a hardware product, when properly installed on the hardware product, are warranted not to fail to execute their programming instructions due to defects in materials and workmanship. If HP receives notice of such defects during their warranty period, HP shall repair or replace software media and firmware which do not execute their programming instructions due to such defects. HP does not warrant that the operation of the software, firmware or hardware shall be uninterrupted or error free.

LIMITATION OF WARRANTY

The foregoing warranty shall not apply to defects resulting from improper or inadequate maintenance by Buyer, Buyer-supplied software or interfacing, unauthorized modification or misuse, operation outside of the environmental specifications for the product, or improper site preparation or maintenance.

NO OTHER WARRANTY IS EXPRESSED OR IMPLIED. HEWLETT-PACKARD SPECIFICALLY DISCLAIMS THE IMPLIED WARRANTIES OF MERCHANTABILITY AND FITNESS FOR PARTICULAR PURPOSE.

EXCLUSIVE REMEDIES

THE REMEDIES PROVIDED HEREIN ARE BUYER'S SOLE AND EXCLUSIVE REMEDIES. HEWLETT-PACKARD SHALL NOT BE LIABLE FOR ANY DIRECT, INDIRECT, SPECIAL, INCIDENTAL, OR CONSEQUENTIAL DAMAGES, WHETHER BASED ON CONTRACT, TORT, OR ANY OTHER LEGAL THEORY.

ASSISTANCE

Product maintenance agreements and other customer assistance agreements are available for Hewlett-Packard products.

For any assistance, contact your nearest Hewlett-Packard Sales and Service Office. Addresses are provided at the back of this manual.



SAFETY SUMMARY

The following general safety precautions must be observed during all phases of operation, service, and repair of this instrument. Failure to comply with these precautions or with specific warnings elsewhere in this manual violates safety standards of design, manufacture, and intended use of the instrument. Hewlett-Packard Company assumes no liability for the customer's failure to comply with these requirements. This is a Safety Class 1 instrument.

GROUND THE INSTRUMENT

To minimize shock hazard, the instrument chassis and cabinet must be connected to an electrical ground. The instrument is equipped with a three-conductor ac power cable. The power cable must either be plugged into an approved three-contact electrical outlet or used with a three-contact to two-contact adapter with the grounding wire (green) firmly connected to an electrical ground (safety ground) at the power outlet. The power jack and mating plug of the power cable meet International Electrotechnical Commission (IEC) safety standards.

DO NOT OPERATE IN AN EXPLOSIVE ATMOSPHERE

Do not operate the instrument in the presence of flammable gases or fumes. Operation of any electrical instrument in such an environment constitutes a definite safety hazard.

KEEP AWAY FROM LIVE CIRCUITS

Operating personnel must not remove instrument covers. Component replacement and internal adjustments must be made by qualified maintenance personnel. Do not replace components with power cable connected. Under certain conditions, dangerous voltages may exist even with the power cable removed. To avoid injuries, always disconnect power and discharge circuits before touching them.

DO NOT SERVICE OR ADJUST ALONE

Do not attempt internal service or adjustment unless another person, capable of rendering first aid and resuscitation, is present.

DO NOT SUBSTITUTE PARTS OR MODIFY INSTRUMENT

Because of the danger of introducing additional hazards, do not install substitute parts or perform any unauthorized modification to the instrument. Return the instrument to a Hewlett-Packard Sales and Service Office for service and repair to ensure the safety features are maintained.

DANGEROUS PROCEDURE WARNINGS

Warnings, such as the example below, precede potentially dangerous procedures throughout this manual. Instructions contained in the warnings must be followed.









Warning



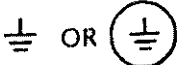

Dangerous voltages, capable of causing death, are present in this instrument. Use extreme caution when handling, testing, and adjusting.

SAFETY SYMBOLS

General Definitions of Safety Symbols Used On Equipment or In Manuals.

	Instruction manual symbol: the product will be marked with this symbol when it is necessary for the user to refer to the instruction manual in order to protect against damage to the instrument.
	Indicates dangerous voltage (terminals fed from the interior by voltage exceeding 1000 volts must be so marked.)
	Protective conductor terminal. For protection against electrical shock in case of a fault. Used with field wiring terminals to indicate the terminal which must be connected to ground before operating equipment.
	Low-noise or noiseless, clean ground (earth) terminal. Used for a signal common, as well as providing protection against electrical shock in case of a fault. A terminal marked with this symbol must be connected to ground in the manner described in the installation (operating) manual, and before operating the equipment.
	Frame or chassis terminal. A connection to the frame (chassis) of the equipment which normally includes all exposed metal structures.
	Alternating current (power line.)
	Direct current (power line.)
	Alternating or direct current (power line.)

Warning  The **WARNING** sign denotes a hazard. It calls attention to a procedure, practice, condition or the like, which if not correctly performed or adhered to, could result in injury or death to personnel.

Caution  The **CAUTION** sign denotes a hazard. It calls attention to an operating procedure, practice, condition or the like, which, if not correctly performed or adhered to, could result in damage to or destruction of part or all of the product.

Note  The **NOTE** sign denotes important information. It calls attention to procedure, practice, condition or the like, which is essential to highlight.

Table of Contents

Volume II

Chapter 15: Math & Auto Math

Purpose Of This Chapter	15-1
Waveform Math	15-1
Waveform Math Overview	15-2
Softkey Descriptions	15-4
Algebraic Operations	15-6
Square Root	15-8
Reciprocation	15-8
Negation	15-9
Differentiation/Integration	15-9
Artificial Integration/Differentiation	15-11
Calculating Open-loop Response	15-12
Real Part	15-12
Complex Conjugation	15-13
Logs and Antilogs	15-13
FFT and Inverse FFT	15-15
Compress	15-16
Expand	15-16
Extract	15-17
Auto Math	15-18
Programming the Auto Math table	15-18
Softkey Descriptions	15-20
The Auto Math Label	15-22
The Auto Math table Can Be Started In Two Ways:	15-23

Chapter 16: Curve Fit

Purpose of This Chapter	16-1
Curve Fit Overview	16-2
Curve Fit Operating Modes	16-3
Basic Curve Fit Set Up	16-4
Starting the Curve Fitter	16-7
Basic Example: s-Domain Curve Fit	16-10
When to Use Auto Order or User Order	16-15
Obtaining a Good Model	16-16
Data Errors	16-16
Accounting for Response Outside Measurement Span	16-19
The Fit Region	16-20
S-Domain Fit Region	16-20
Z-Domain Fit Region	16-26

Table of Contents

How Coherence is Used in Curve Fitting	16-35
How Auto Order Defines a Good Fit	16-36
Effect on Weighting Function	16-36
The Weighting Function	16-37
Fitting Measurements With Delay	16-38
S-Domain	16-38
Z-Domain	16-38
Fixed Poles and Zeros	16-39
Curve Fit Setup Steps	16-40
Step 1: Choose the source of the data	16-40
Step 2: Choose the Domain (s or z)	16-40
Step 3: Select Auto Order or User Order	16-41
Step 4: Specify the System Order	16-41
Step 5: Set the sample or scaling frequency	16-41
Step 6: Specify Markers	16-42
Step 7: Add known poles and zeros (Optional)	16-43
Step 8: Enter any known delays (Optional)	16-43
Step 9: Specify the Weighting Function (Optional)	16-43
Step 10: Create the Fit	16-45
Step 11: View and Edit the Curve Fit Table	16-46
Key Reference	16-47
The CREATE FIT Menu	16-49
The EDIT TABLE Menu	16-50
The FIT FCTN Menu	16-54
Chapter 17: Synthesis	
Purpose of This Chapter	17-1
Synthesis Overview	17-2
Entering Data in a Synthesis Table	17-2
How Analyzer Configuration Affects Synthesis	17-3
Performing the Synthesis	17-4
Changing Data Formats in a Synthesis Table	17-4
Converting the Domain of a Synthesis Table	17-5
The Synthesis Calculation	17-6
X-axis Units	17-6
Entering a Time Delay	17-6
Entering a Scale Frequency	17-7
The SYNTH Hardkey	17-8
Creating a Synthesis Trace	17-9
The Synthesis Table	17-12
Pole-Zero Data	17-13
Entering Pole-Zero Data: s-Domain	17-13
Entering Pole-Zero Data: z-Domain	17-14
s-Domain Exercise: Pole-Zero Data	17-15
z-Domain Exercise: Pole-Zero Data	17-20
Polynomial Data	17-26
Entering Polynomial Data: s-Domain	17-26
Entering Polynomial Data: z-Domain	17-26
s-Domain Exercise: Polynomial Data	17-28
z-Domain Exercise: Polynomial Data	17-30

Partial Fraction (Pole-Residue) Data	17-34
Entering Pole-Residue Data: s-Domain	17-34
Entering Pole-Residue Data: z-Domain	17-35
Reconstructing Simple Poles	17-37
Reconstructing Complex Conjugate Pole-Pairs	17-38
s-Domain Exercise: Pole-Residue Data	17-40
z-Domain Exercise: Pole-Residue Data	17-43
Converting Domains	17-48
Converting From the s-Domain to the z-Domain	17-48
Converting from the z-Domain to the s-Domain	17-53
Converting Table Formats	17-54
Transferring Synthesis Tables to Curve-Fit Tables	17-55
Key Reference	17-56
Pole-Zero Editing Softkeys	17-57
Polynomial Editing Softkeys	17-59
Pole-Residue Editing Softkeys	17-59
The Synthesis Functions Menu	17-60
Convert to s Menu	17-65
Convert to z Menu	17-68

Chapter A: Connector/Indicator Descriptions

Introduction	A-1
Front Panel	A-3
Rear Panel	A-6

Chapter B: Error And Status Messages

Introduction	B-1
Error Messages	B-2
Status Messages	B-21

Chapter C: Menu Diagrams

Introduction	C-1
A-Z Menu Diagrams	C-3/C-32

Index

Sales Offices

Introduction

This section contains three chapters that describe the analyzer's data operation features:

- Chapter 15: Math & Auto Math
- Chapter 16: Curve Fit
- Chapter 17: Synthesis

Chapter 15 describes the math and auto-math features. The math feature lets you perform mathematical operations on the data block represented by the displayed trace. The auto-math feature lets you program and automate one or more math operations.

Chapter 16 describes the curve-fit feature. This feature lets you generate an $H(s)$ or $H(z)$ model (in pole zero, pole residue, or polynomial format) from measured or synthesized frequency-response data.

Chapter 17 describes the synthesis feature. This feature lets you generate frequency-response curves from an $H(s)$ model, an $H(z)$ model, or the product of both — with or without the effects of a zero-order hold.

Math & Auto Math

Purpose Of This Chapter

This chapter shows you how to use the HP 3563A's math and auto math features — part of the Operators group. It assumes you are familiar with the basic operation of the instrument (at the minimum, you should be familiar with chapter 1 “Introduction” and chapter 2 “Measurement Overview”).

Waveform Math

The HP 3563A offers a number of waveform math capabilities, including:

- Algebraic (+, -, *, /, x)
- Square root
- Reciprocation
- Negation
- Integration/differentiation
- Complex integration/differentiation
- Open-loop from closed-loop response
- Real part
- Complex conjugation
- Logarithm and antilogarithm
- FFT and inverse FFT
- Compress, Expand and Extract

Waveform Math Overview

All softkeys that perform waveform math operations are located under the **MATH** hardkey. Figure 15-1 shows the menu diagram for this key.

Waveform math operates on the data block represented by the displayed trace, not on the trace itself. These operations apply to the active trace(s); if both traces are active, the selected operation applies to both. With the exception of the algebraic operations, compress, expand, and extract, the calculation is performed immediately after the operation is selected. To enter complex values, enter the real and imaginary parts separated by a comma. Floating point numbers are represented by 24-bit mantissas and 8-bit exponents; their numeric range is $\pm 10^{\pm 38}$. Integers are represented in 2's complement, 16-bit form, with a numeric range of $-32,768$ to $+32,767$.

The results of waveform math are noted on the display with M: preceding the display label. For example, if you add a constant to a frequency response trace, the label becomes M:FREQ RESP.

The error message "Trace Not Compatible" is displayed if you attempt math on incompatible traces. The operations not allowed are:

1. ADD,SUB,MPY,DIV on 2 traces where the domain, lin/log x-scale, or number of elements do not match
2. $j\omega$ and $j\omega^{-1}$ on nonfrequency domain traces
3. FFT and FFT^{-1} on log x-axis, histogram/PDF/CDF, orbits, or demod polar
4. Any math on time capture buffer or demod preview displays.
5. COMPRESS or EXPAND on other than baseband 1024 complex-point linear frequency resolution traces.
6. EXTRACT on other than linear frequency resolution traces.

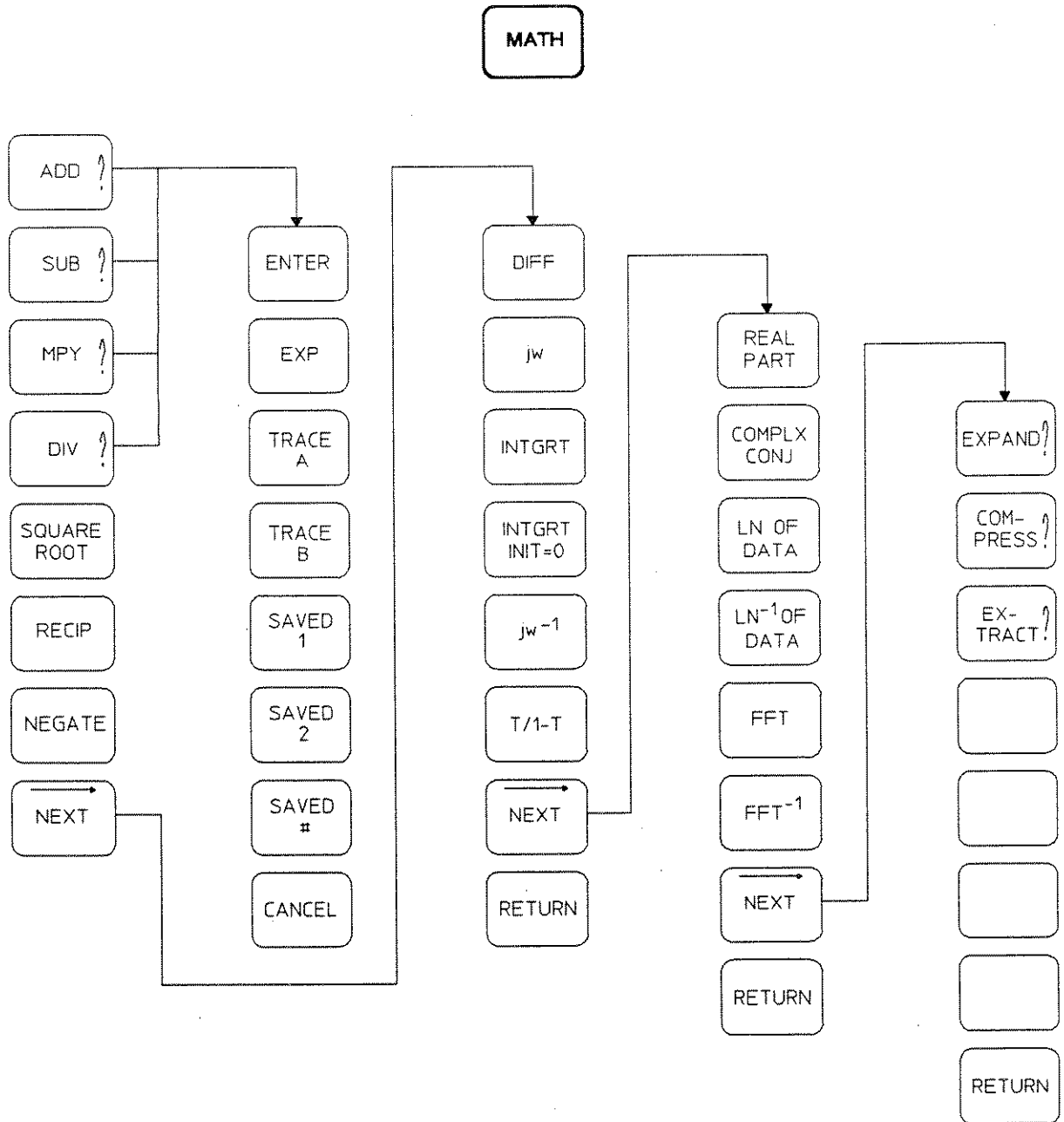

Figure 15-1. MATH Menu Diagram

Softkey Descriptions

The softkeys that appear when you press **MATH** do the following:

ADD	Selects addition; see “Algebraic Operations.”
SUB	Selects subtraction; see “Algebraic Operations.”
MPY	Selects multiplication; see “Algebraic Operations.”
DIV	Selects division; see “Algebraic Operations.”
SQUARE ROOT	Calculates the square root of the active trace; see “Square Root.”
RECIP	Reciprocates the active trace; see “Reciprocation.”
NEGATE	Negates the active trace; see “Negation.”
NEXT	Displays other math options.

The softkeys that appear when you press **MATH NEXT** do the following:

DIFF	Differentiates the active trace; see “Differentiation/ Integration.”
$j\omega$	Multiplies the active frequency domain trace by $j\omega$; see “Artificial Differentiation/Integration.”
INTGRT	Integrates the active trace; see “Differentiation/Integration.”
INTGRT INIT = 0	Integrates the active trace without including the first bin; see “Differentiation/Integration.”
$j\omega^{-1}$	Divides the active frequency domain trace by $j\omega$; see “Artificial Differentiation/Integration.”
$\frac{T}{1-T}$	Calculates open-loop response from measured closed loop response, where T is the active trace; see “Calculating Open-Loop Response.” T must be positive.
NEXT	Displays other math options.
RETURN	Displays the previous menu.

The softkeys that appear when you press **MATH**, **NEXT**, **NEXT** do the following:

REAL PART	Zeros out the imaginary part of complex measurement data; see “Real Part.”
COMPLX CONJ	Calculates the complex conjugate of the active trace; see “Complex Conjugation.”
LN OF DATA	Calculates the natural logarithm of the active trace; see “Logs and Antilogs.”
LN ⁻¹ OF DATA	Calculates the natural anti-logarithm (exponential) of the active trace; see “Logs and Antilogs.”
FFT	Calculates the fast Fourier transform (FFT) of the active trace; see “FFT and Inverse FFT.”
FFT ⁻¹	Calculates the inverse FFT of the active trace; see “FFT and Inverse FFT.”
NEXT	Displays other math options.
RETURN	Displays the previous menu.

The softkeys that appear when you press **MATH**, **NEXT**, **NEXT**, **NEXT** do the following:

EXPAND	Expands a segment in a block to fill the entire block (you enter an integer (N) to specify the size of the segment (1/N of the points)); see “Expand”.
COM- PRESS	Compresses a block into a segment and replicates the segment to fill the entire block (you enter an integer (N) to specify the size of the segment (1/N of the points)); see “Compress”.
EX- TRACT	Extracts a segment in a block and fills the entire block with the segment (you enter a start and stop frequency to specify the size of the segment); see “Extract”.
RETURN	Displays the previous menu.

Algebraic Operations

The algebraic operations (ADD, SUB, DIV, MPY) require three steps:

1. Select the active trace as the first operand.
2. Select the math operation.
3. Select a displayed or stored trace or a numeric constant as the second operand.

When the operation is selected, the following menu is displayed to allow you to choose the second operand:

ENTER	Used to enter a numeric constant as the second operand.
EXP	Used to enter a numeric constant in exponential notation. Numbers entered before EXP is pressed are the base, and number entered after are the exponent. For example, 100000 is entered as 1 EXP 5.
TRACE A	Selects trace A as the second operand.
TRACE B	Selects trace B as the second operand.
SAVED 1	Selects saved data trace #1 as the second operand. See "Saving and Recalling States and Displays" in chapter 8 for information on the saved traces.
SAVED 2	Selects saved data trace #2 as the second operand. See "Saving and Recalling States and Displays" in chapter 8 for information on the saved traces.
SAVED #	Enters the trace stored in a User Save Data Block for math operations. The trace is available from any of the five data blocks, User Save Data 1, 2, 3, 4, or 5. This softkey is a terminator key type. Press the data block number before pressing SAVED #. For example, to add User Save Data Block 5 to the active trace, press ADD, press 5 (Entry group), and then press SAVED #. Autosequence and Auto Math tables containing this softkey <i>cannot</i> be recalled on the HP 3562A. For more information about the use of the User Save Data Block, refer to the description of the SAVE DATA# softkey in chapter 8.
CANCEL	Cancels the math operation.

Note



To divide log magnitude traces, use the DIV softkey, not SUB. A log magnitude trace is strictly a function of the display. The data are stored in linear format, so division is required.

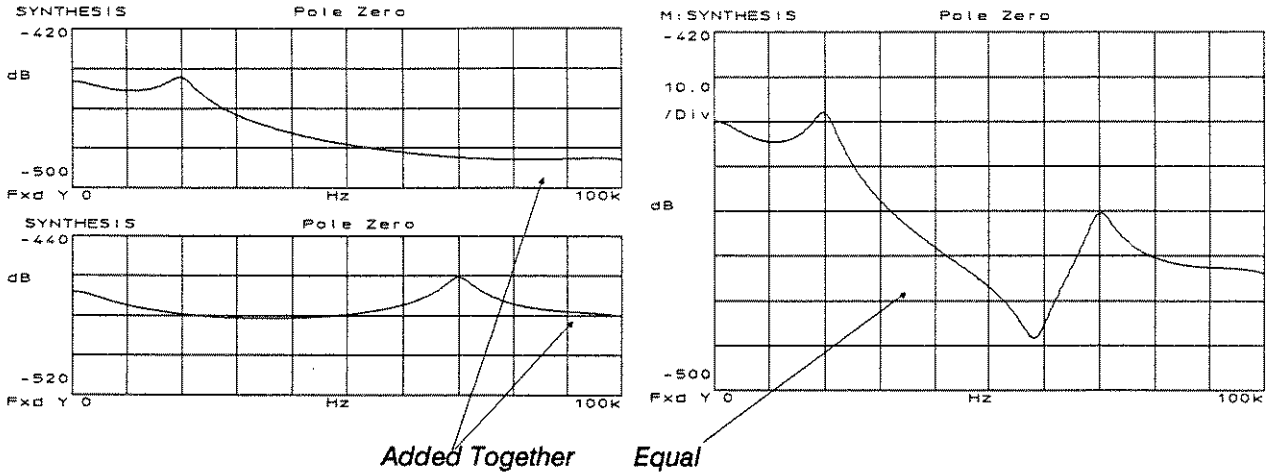

Figure 15-2. Addition

Figure 15-2 shows an example of adding two traces.

Square Root

If the trace is a baseband time record (2048 real points), SQUARE ROOT calculates the square root of the absolute value of each point in the active trace. For all other traces (1024 complex points), SQUARE ROOT calculates the complex square root of each point in the active trace, resulting in a complex trace.

Figure 15-3 shows an example square root operation.

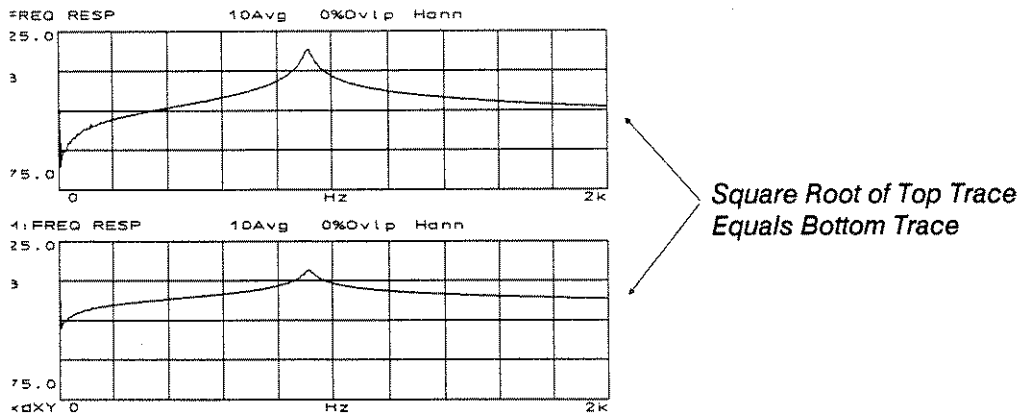

Figure 15-3. Square Root

Reciprocation

RECIP divides each point in the active trace into one; figure 15-4 shows an example.

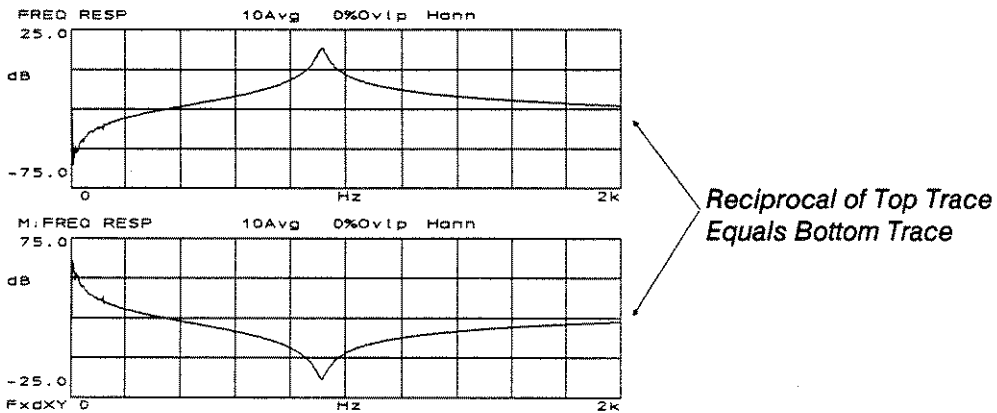

Figure 15-4. Reciprocation

Negation

NEGATE individually multiplies the real and imaginary parts of the measurement data by minus one; figure 15-5 shows an example. The traces in figure 15-5 show the results of negating a frequency response. The top trace shows the frequency response magnitude: the bottom trace shows the real data. The left traces show the frequency response before negation. The right traces show the results after negation.

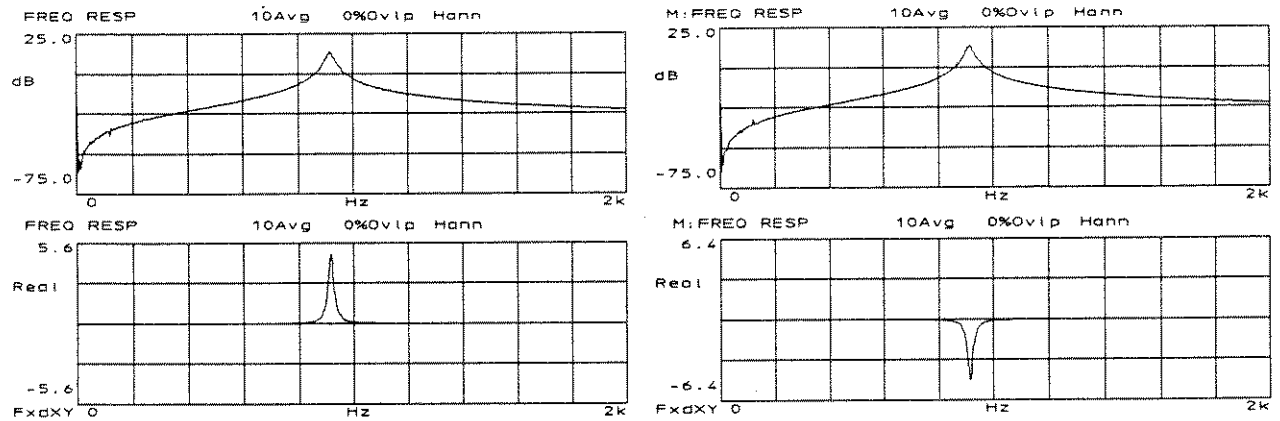
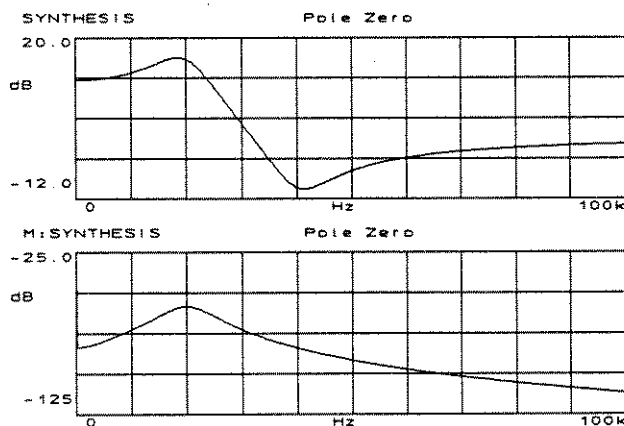

Figure 15-5. Negation

Differentiation/Integration

DIFF differentiates the active trace by calculating the difference between adjacent points on the X-axis, then divides each difference by the bin spacing; figure 15-6 shows an example.



Trace B is the Derivative of Trace A

Figure 15-6. Differentiation

INTGRT integrates the active trace by summing the discrete areas contained at each point on the display. Figure 15-7 shows an example of integration. INTGRT sums all points, while INTGRT INIT = 0 initializes the first point to zero.

Trace B is the Numeric Integral of Trace A

Notice that the y-axis on Trace B is scaled by Δt (in this case, $\Delta t = 512\text{ms}/2048\text{ points} = 250\mu\text{s}$). The marker position shown is at 249.75 ms, which covers the first 1000 points. The marker readout on Trace B (Yb) shows 253.849 mV at this marker position ($1.01537\text{V} \times 1000\text{ points} \times 250\mu\text{s} = 253.849\text{ mV}$).

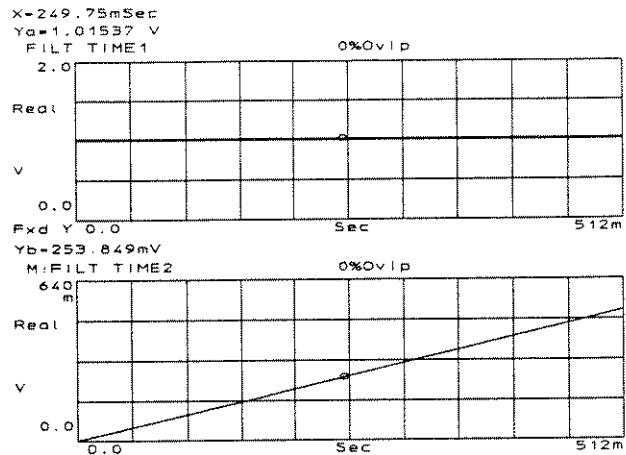

Figure 15-7. Integration (INTGRT)

INTGRT INIT = 0 initializes the first point in the display to zero (effectively excluding it from the integration), then integrates the active trace in the same manner as INTGRT. Figure 15-8 shows an example.

Similar to previous figure.

However, notice that the marker readout on Trace B (Yb) shows 253.595 mV instead of 253.849 mV as in the previous figure. This occurs because INTGRT INIT = 0 sets the first point to zero ($1.01537\text{V} \times 999\text{ points} \times 250\mu\text{s} = 253.595\text{ mV}$).

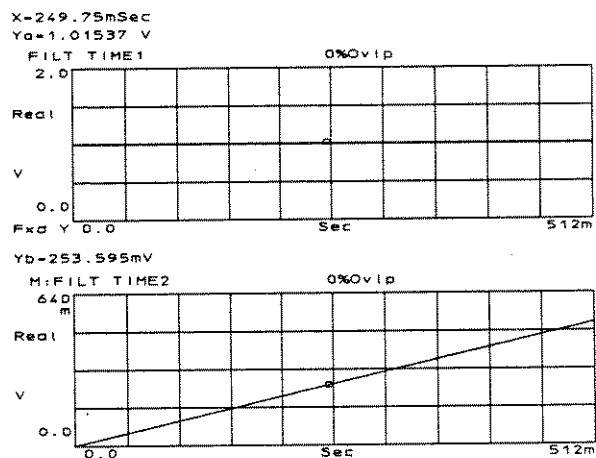

Figure 15-8. Integration (INTGRT INIT = 0)

Artificial Integration/Differentiation

Artificial differentiation is performed by multiplying the trace by $j2\pi \Delta f$. This function provides the frequency spectrum of the time domain derivative.

Value at X Marker Readout on Trace B equals:

400 Bins (50 kHz divided by Δf of 125 Hz)
Times Δf of 125 Times 2π Times Value of Trace A (about 1.0) = 314.885 K

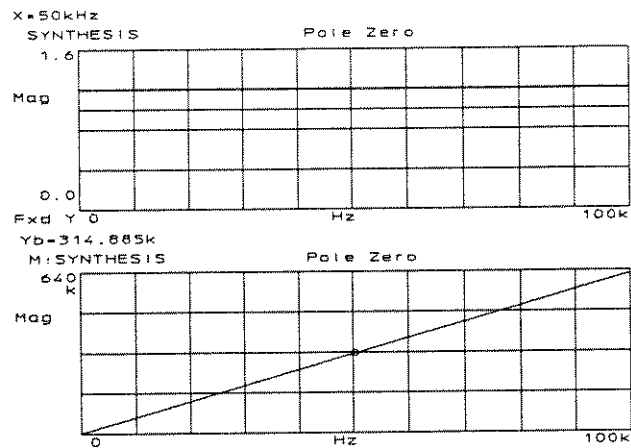

Figure 15-9. Artificial Differentiation

Artificial integration is performed by dividing the trace by $j2\pi \Delta f$. This function provides the frequency spectrum of the time domain integral.

Trace B is the result of Artificially Integrating Trace A

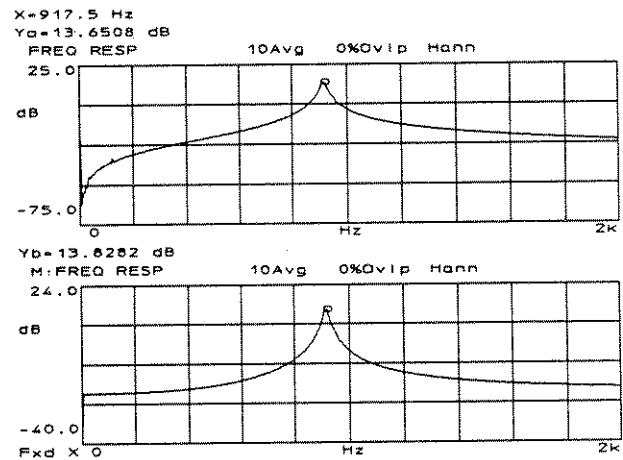

Figure 15-10. Artificial Integration

Calculating Open-loop Response

T/1 - T calculates open-loop response from a measured closed-loop frequency response curve, as the example in figure 15-11 shows. To yield a valid result, the measured response (T) must be the active trace.

Trace B = T/1-T

Where T is Trace A

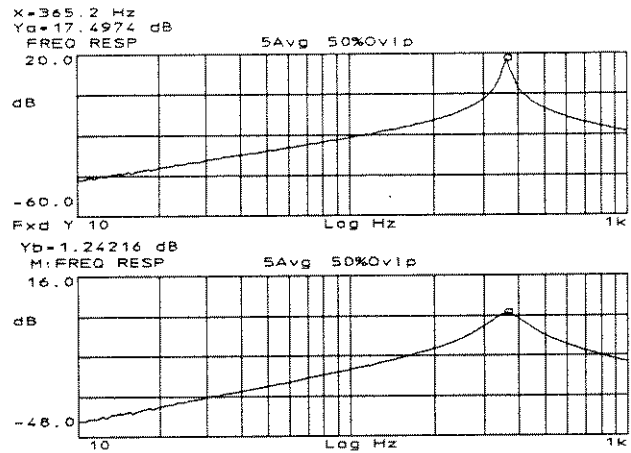

Figure 15-11. Calculating Open-Loop Response

Real Part

REAL PART zeros out the imaginary part of complex measurement data. This differs from the REAL display coordinate (under **COORD**) which only displays the real part of a complex block and leaves the imaginary part untouched.

*Trace B is Real Part of
Frequency Response
in Trace A*

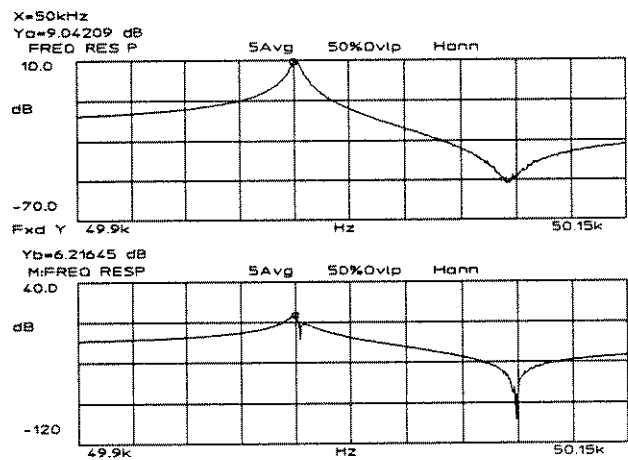

Figure 15-12. Real Part

Complex Conjugation

COMPLX CONJ calculates the complex conjugate of the active trace; figure 15-13 shows an example.

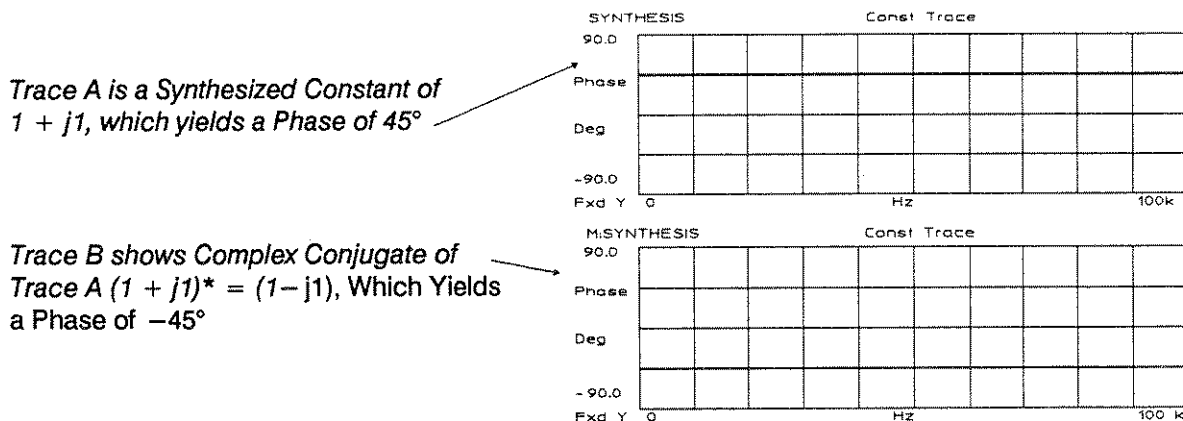

Figure 15-13. Complex Conjugation

Logs and Antilogs

LN OF DATA calculates the \log_e of the active trace, leaving the natural log of the magnitude in the real part and the phase in radians in the imaginary part. Figure 15-14 shows an example.

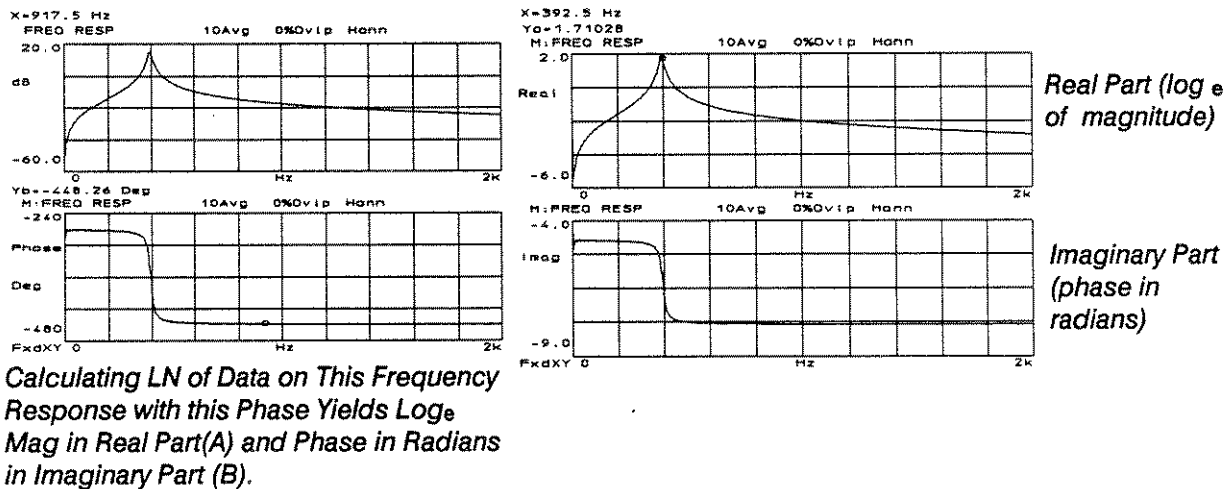
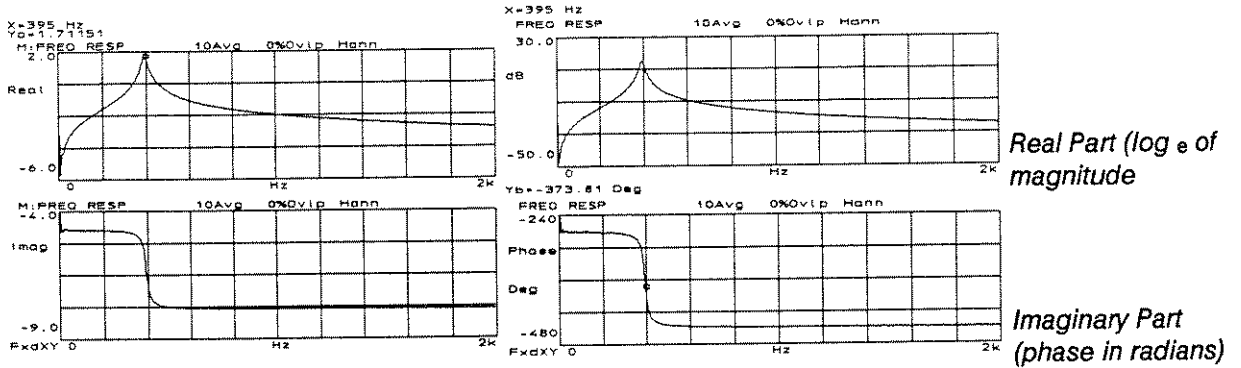

Figure 15-14. LN OF DATA

LN^{-1} OF DATA calculates the antilog (\log_e) of the active trace, taking phase in radians from the imaginary part of the data and \log_e of the magnitude from the real part. The magnitude is assumed to be in the real part; phase in the imaginary part.



With Log_e Mag in Real and Phase in Radians in Imaginary, Calculating LN^{-1} of Data Yields this Frequency Response with this Phase

Figure 15-15. LN^{-1} OF DATA

FFT and Inverse FFT

FFT computes a 1024-line FFT from either a 1024-point complex record or a 2048-point real record. For FFTs on time domain traces, 1024 lines are produced; 801 or 1024 lines are saved and displayed (depending on the selection of **WINDOW LINES** 801 or **LINES** 1024). Because of dithering in the computation, FFTs on identical data do not always produce identical results. The scale factor for the FFT operation is 1/1024. Figure 15-16 shows an example of the FFT command.

Trace B Linear Spectrum Resulting from Computing FFT of 5 kHz Sine Wave in Trace A

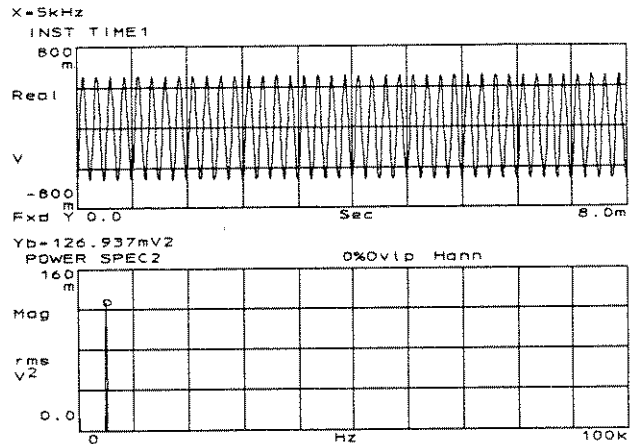

Figure 15-16. FFT

FFT^{-1} performs an inverse fast Fourier transform (FFT) on the active trace. Figure 15-17 shows an example. If you have performed an FFT on a time record, then transformed it back to the time domain using FFT^{-1} , the analyzer adds 223 zeros outside the frequency span to fill the 223 lines discarded by the FFT (if it was an 801 point data block; see the description in chapter 3 for **LINES** 801). The FFT^{-1} is 6 to 10 dB noisier than FFT. The scale factor for the inverse FFT operation is 1.

Impulse Response in Trace B resulted from Computing Inverse FFT of Frequency Response in Trace B.

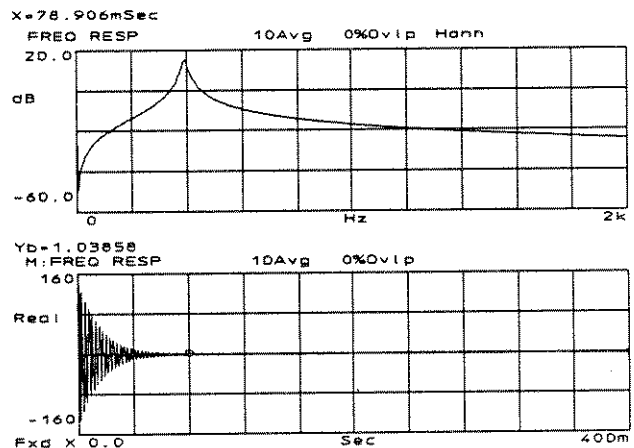

Figure 15-17. Inverse FFT

Compress

COMPRESS squeezes the active trace into a segment and replicates the segment with a mirror image in successive block segments to fill the entire block. This results in reflecting the data around the Nyquist frequency, $1/2$ of the sampling frequency, $F_s/2$. You define the segment by specifying the denominator of a fraction, $1/N$. N can equal any power of 2 up to 512.

Note



COMPRESS can only be used with linear resolution or linear swept sine frequency domain traces with 1024 complex points. COMPRESS can not be used with traces from log resolution or log swept sine measurements.

This operation allows you to increase the bin spacing of a trace by a power of two and thus make direct comparisons between measurements with effective sample rates differing by powers of two.

Expand

EXPAND enlarges a segment of the data in the active trace to fit the entire trace. This operation allows you to decrease the bin spacing of a trace by a power of two and thus make direct comparisons between measurements with effective sample rates differing by powers of two. You define the segment by specifying the denominator of a fraction, $1/N$. N can equal any power of 2 up to 512.

Note



COMPRESS can only be used with linear resolution or linear swept sine frequency domain traces with 1024 complex points. COMPRESS can not be used with traces from log resolution or log swept sine measurements.

EXPAND uses the first $1/N$ points of the active trace to fit the entire block. A linear interpolation between the data points is used to fill up the block.

Extract

EXTRACT takes a segment of data in the active trace (between your Start and Stop values) and fills the entire block with the segment. This operation allows you to decrease the bin spacing of a trace by a rational factor and thus make direct comparisons between measurements with different sample rates. Values may be expressed in terms of Hertz (Hz) or defined by the X1 and X2 marker values. The first value entered is the start value; the second value entered is the stop value.

Note



EXTRACT can only be used with linear resolution or linear swept frequency-domain traces. EXTRACT cannot be used with traces from log resolution or log swept sine measurements.

Interpolation between the data points is used to fill up the block as needed. There must be at least three points in the source trace between your start and stop values to extract data.

You can change the number of lines in the resultant trace (801 to 1024 or 1024 to 801) by setting the LINES softkey in the **WINDOW** menu.

Auto Math

The HP 3563A's auto math feature allows you to program math operations using the Active Trace keys and the softkeys in the **MATH** and **MEAS DISP** menus. The current auto math table is saved in nonvolatile memory inside the instrument and is not erased when power is removed. Tables can also be stored in disc memory; see chapter 11 for instructions. The next two sections explain how to program and start the auto math table.

An important feature of auto math is that it can be selected as a measurement display in the linear, log and swept sine modes. This allows you to view the math results while a measurement is in progress.

The table is limited to 99 lines, but it may fill with fewer than 99 lines depending on the commands used. (The limit is 99 lines or 1200 characters.) The message in the top right corner of the table "xxx Keys Left" tells you how many key strokes are available. Also, keep in mind the instrument states under which you may run the auto math table. A table created to operate on a given set of traces may not work if you (or the analyzer) provide different traces.

Programming the Auto Math table

Commands are programmed in the auto math table in the same manner as they are executed directly from the front panel. For example, to add trace B to the active trace, enter **MATH**, **ADD**, **TRACE B** as a command. You can select one measurement display for each trace, and the **MEAS DISP** selections must precede the **MATH** selections. To fill or edit the auto math table, press **AUTO MATH**. Figure 15-18 shows the menu diagram for **AUTO MATH**.

Note



You must pause the measurement (press **PAUSE/CONT**) to edit the auto-math table.

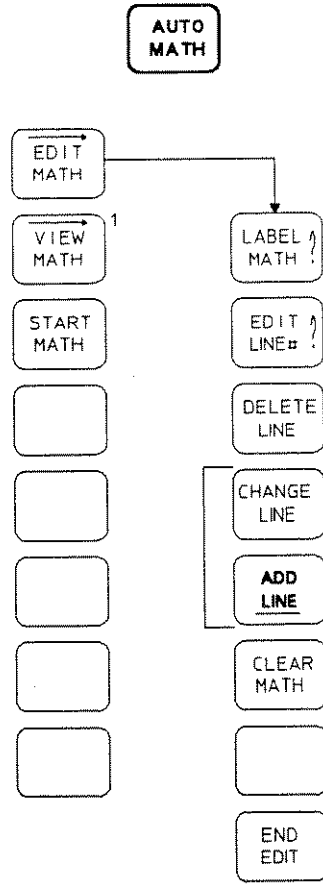

¹This softkey has the same effect as pressing [EDIT MATH] followed by [END EDIT]

Figure 15-18. AUTO MATH Menu Diagram

Softkey Descriptions

The softkeys available under **AUTO MATH** do the following (described in the order that they appear in figure 15-18):

EDIT MATH	Displays the auto math table and its editing menu.
VIEW MATH	Displays the auto math table but does not allow any editing. This is useful to display the table for plotting or saving to disc.
START MATH	Starts the auto math table; see the next section, "Starting the Auto Math table."
LABEL MATH	Used to add a label to the auto math table; see "The Auto Math Label" following this menu.
EDIT LINE#	Used to select a line for editing. This only selects the line; the actual editing is done with DELETE LINE, CHANGE LINE and ADD LINE.
DELETE LINE	Deletes the edit line.
CHANGE LINE	Allows the edit line to be changed. When this is active, the edit line changes as you enter new commands.
ADD LINE	Allows a line to be added after the edit line. To add a line before the current line #1, use EDIT LINE# to move the pointer to line #0, then add the new line.
CLEAR MATH	Press twice to clear the auto math table. The message "Push Again to Clear" is displayed to allow you to confirm that the table is to be cleared.
END EDIT	Exits the editing mode and saves the changes made during the current editing session.

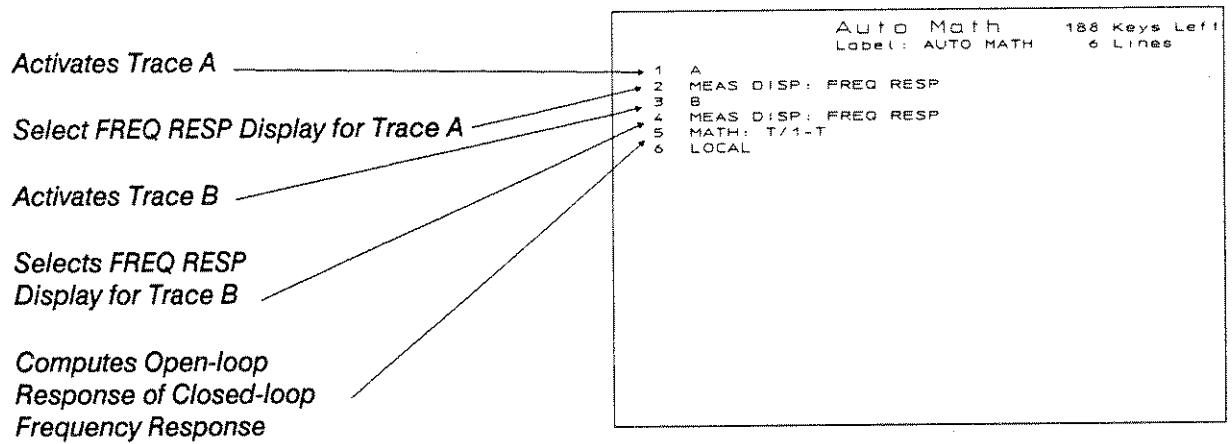

Figure 15-19. The Auto Math Table

The Auto Math Label

The label (entered with LABEL MATH) serves three purposes:

1. It is displayed at the top of the table to identify the function of each table. This is helpful when tables are plotted or stored on disc.
2. It replaces the AUTO MATH softkey label in the **MEAS DISP** menu (linear resolution, log resolution, and swept sine modes only). This allow you to start the auto math table and display the results while a measurement is in progress.
3. It appears on top of the active trace (in the same field as the other **MEAS DISP** selections).

To enter the label, press LABEL MATH, and the HP 3563A shifts into the alpha mode. In this mode, the hardkeys (except **LINE** and **HELP**) are converted to their blue labels, and the following menu is displayed:

ENTER	Saves the current alpha entry, displays the label in the table, and exits the alpha mode.
SPACE FORWRD	Moves the cursor one space forward to edit an entry. Use the ARROW keys and the "BL" key to add blanks.
SPACE BACKWD	Moves the cursor one space backward without erasing any characters. To erase, use BACK SPACE .
INSERT ON OFF	When this is pressed ON, characters are inserted at the cursor position. When pressed OFF, characters are written over existing ones.
DELETE CHAR	Deletes the character at the cursor position.
CLEAR LINE	Clears the alpha entry from the cursor position to the end of the line,
CANCEL ALPHA	Clears the current entry and exits the alpha mode.

Labels are limited to two lines of six characters each. Enter the first and second lines separated by a comma (,).

The Auto Math table Can Be Started In Two Ways:

1. Press **AUTO MATH**, then the START MATH softkey.
2. Press **MEAS DISP**, then the AUTO MATH softkey. Note that the AUTO MATH softkey label is replaced by the math label, if one was programmed in the table (POWER TEST, for example). The auto math table can be started from the **MEAS DISP** menu in linear resolution, log resolution, and swept sine modes.

```

Auto Math      1189 Keys Left
Label: OPENLO  5 Lines
1 A
2 MEAS DISP: FREQ RESP
3 B
4 MEAS DISP: FREQ RESP
5 MATH: T/1-T
    
```

Calculates Open-loop Response from a Measured Close-loop Response

```

Auto Math      1186 Keys Left
Label: CEPSTR   4 Lines
1 A
2 MEAS DISP: POWER SPEC1
3 MATH: LN OF DATA
4 MATH: FFT
    
```

Computes Cepstrum

```

Auto Math      1189 Keys Left
Label: COHER    5 Lines
1 A
2 MEAS DISP: COHER
3 B
4 MEAS DISP: POWER SPEC2
5 MATH: MPY: TRACE A
    
```

Calculates Coherent Output Power

```

Auto Math      1182 Keys Left
Label: NONCOH   6 Lines
1 A
2 MEAS DISP: POWER SPEC2
3 B
4 MEAS DISP: COHER
5 MATH: NEGATE
6 MATH: ADD 1
7 A
8 MATH: MPY: TRACE B
    
```

Calculates Noncoherent Output Power

```

Auto Math      1193 Keys Left
Label: CAL CU   3 Lines
1 A
2 MEAS DISP: POWER SPEC1
3 MATH: MPY: SAVED 1
    
```

Multiplies Trace A by a Trace Stored in SAVE DATA #1

```

Auto Math      1182 Keys Left
Label: S/N RA   6 Lines
1 A
2 MEAS DISP: COHER
3 B
4 MEAS DISP: COHER
5 MATH: NEGATE
6 MATH: ADD 1
7 A
8 MATH: DIV: TRACE B
    
```

Computes S/N Ratio

Figure 15-20. Auto Math Examples

Curve Fit

Purpose of This Chapter

This chapter shows you how to use the HP 3563A's curve-fit feature. The curve-fit feature allows you to find a mathematical model which closely approximates the frequency response data obtained from measured or synthesized data.

This chapter is divided into two parts. The first half explains how to use the curve-fit features. The second half is a key reference that contains detailed descriptions of the softkeys available under the **CURVE FIT** hardkey. Begin with the first half of this chapter to learn the curve-fit features. As you read, refer to the key reference if you need additional information.

Note



See chapter 4 in the *HP 3563A Getting Started Guide* for additional curve-fit examples and applications.

Also, see Product Note HP 3562A-3, "Curve Fitting in the HP 3562A", for basic information on the HP 3563A curve fitter.

Additionally, see Product Note HP 3563A-1, "z-Domain Curve Fitting in the HP 3563A Analyzer", for z-domain curve-fit examples. Among other things, this product note explains the difference between the curve-fit sample rate and the measurement sample rate, which is important to understand when using the z-domain curve fitter in some of its more powerful applications.

Curve Fit Overview

Curve fitting is a powerful analytical tool that is basically the opposite of synthesis. With synthesis, you enter a known transfer function model into a table and create a frequency response trace. With curve fitting, you start with a frequency response trace and find a model which corresponds to that trace. Often, the trace math capabilities of the HP 3563A will be used to manipulate the data, or to combine it with data from another source before the curve fitting is performed.

The HP 3563A has two curve fitters that can derive a linear system model from either measured or synthesized frequency response data. The pole/zero model is developed by calculating a weighted least-squares fit of the frequency response data to a rational polynomial.

The two curve fitters in the HP 3563A are:

- s-Domain Curve Fitter
- z-Domain Curve Fitter

Each curve fitter has its own curve fit table. The tables are completely independent and are used to display set up information and curve fit results. The operation of one curve fitter does not affect the contents of the other curve fitter's table.

The s-domain curve fitter finds $H(s)$ models, where s is a complex variable with units of Hz. The **s-domain curve fit** is of the form:

$$H(s) = K \frac{(a_1s^0 + a_2s^1 + a_3s^2 + \dots a_ns^{n-1})}{(b_1s^0 + b_2s^1 + b_3s^2 + \dots b_ms^{m-1})}$$

where: K is the system Gain

The z-domain curve fitter finds $H(z)$ models based on the frequency response data and on the specified sample frequency. The sample frequency determines the periodicity of the frequency response for the $H(z)$ model found. Usually, for measured data, this sample frequency is the same as that used in the frequency response measurement on the system under test. However, if the goal is to redesign a digital filter to operate at a lower sample frequency, then the lower sample frequency can be used to develop the model. The curve fitter develops the model by calculating a weighted least-squares curve fit of a rational polynomial to the measured frequency response. The **z-domain curve fit** is of the form:

$$H(z) = K \frac{(a_1z^0 + a_2z^1 + a_3z^2 + \dots a_nz^{n-1})}{(b_1z^0 + b_2z^1 + b_3z^2 + \dots b_mz^{m-1})}$$

where: K is the system Gain

Once either an s-domain or z-domain polynomial curve fit is complete, the numerator polynomial and denominator polynomial are factored to obtain poles and zeros. Only real coefficients are found for the polynomials. Hence, the roots of the polynomials (zeros and poles) appear as real terms. The results are tabulated in the s- or z-domain curve-fit tables. Each table is read in the same way as its corresponding pole-zero synthesis table.

Curve Fit Operating Modes

Each curve fitter (the s-domain curve fitter and the z-domain curve fitter) has two operating modes:

- User Order
- Auto Order

User Order

In user order, the curve-fit routine uses only the specified numerator and denominator order. A model is developed, with these orders, that has a frequency response which comes as close as possible to the frequency response data in a least-squares sense.

In user-order mode, there is no higher level curve-fit algorithm as in auto-order mode. Thus, user order does not perform a search for the best fit by trying different numerator and denominator orders. In user-order mode, the least-squares curve-fit technique is not iterative. Given the same frequency response and coherence functions, the fit model is unique. Therefore, if you repeat a curve fit in user order (using the same data and set up parameters), you obtain the same answer.

User order does not search for pole and zero terms to cancel. This allows you to find a system with pole-zero pairs which might otherwise be cancelled during an auto-order curve fit (auto order looks for pole and zero terms close enough together to cancel).

Auto Order

In auto-order mode, the auto-order algorithm operates the curve-fit routine with successively larger system orders until it finds a good model, or until the maximum system order is reached. Both the maximum numerator order (number of zeros) and the maximum denominator order (number of poles) can be specified. For example, entering 3 for the numerator upper bound restricts the auto-order algorithm to finding a model that has a maximum of three zeros.

The auto-order algorithm starts with a numerator/denominator order of 1,1 and does a fit using the curve-fit routine given this order. The auto-order algorithm automatically performs a synthesis on the fit model and compares this frequency response to the measured frequency response. If the fit is poor, the orders are incremented to 2,2, and another fit is done. This search upwards in order continues until a good match is found or the upper bounds are reached. The upper bounds do not have to be equal. The auto-order algorithm holds the order at the first upper bound reached, and lets the other order climb to the higher order if the fits are poor. If both upper bounds are reached before a good fit is found, the auto-order algorithm returns the fit which came closest to the measured frequency response.

When a good fit is found, the auto-order algorithm tries to reduce the numerator order and denominator order if it determines that this has the potential of creating a lower-order model that still provides a close match to the measured frequency response. This order reduction usually results in a numerator order lower than the denominator order. The s-domain curve-fit algorithm automatically imposes the restriction that the numerator order can never be larger than the denominator order (the z-domain curve-fit algorithm does not have this restriction).

The curve-fit algorithm uses the coherence function to determine how large the difference can be between the synthesis of the fit model and the measured frequency response in defining a good fit. See "How Coherence is Used in Curve Fitting" for more details on the definition of a good fit.

Once a good fit is found (or a fit with minimum error is returned if none of the fits meet the 'good' criterion), the numerator and denominator polynomials from the fit are factored into pole/zero form. Then, the curve-fit algorithm searches for coincident poles and zeros to cancel. Coherence determines how close terms need to be before cancellation can occur. The final results are tabulated in the curve-fit table.

Basic Curve Fit Set Up

The following steps are the minimum required for performing a curve fit. They do not need to be done in the order shown.

1. Select the Curve Fitter (s or z)
2. Specify the numerator order and denominator order
3. Select the source of data to be fit
4. Select Auto Order or User Order
5. Specify the Sample Frequency for the z-Domain curve-fit model (if in z domain)
6. Place X-markers
7. Start the curve fitter.

These and other optional steps are covered in more detail in "Curve Fit Setup Steps."

Once these setup parameters are entered, they do not need to be reentered before subsequent curve fits unless they need to be changed. For example, once the number of poles and zeros have been entered, several curve-fits can be performed. The only table entries that change after a curve fit are the un-fixed poles and zeros, and the gain. Any pole or zero terms which have an arrow symbol by them are considered fixed, and are not overwritten. Instead, they are forced to be present in the final model. For more information on fixed poles and zeros, see "Fixed Poles and Zeros."

Selecting the Curve Fitter

The choice of a curve fitter is usually determined by the source of the data. For measured data from continuous systems, use the s-domain curve fitter. For discrete time systems (digital), use the z-domain curve fitter. However, there is no restriction against using the z-domain fitter on continuous system data (and vice-versa). This might be done, for example, to design a digital filter that closely approximates an analog filter.

Specify the numerator order and denominator order

If user order is selected, enter the number of poles and zeros to be used in the model.

If auto order is selected, enter the maximum number of poles and zeros to be used in the curve fit. By default, auto order uses a maximum of 40 poles and 40 zeros.

The maximum number of poles and zeros that you can specify affects the amount of time that it takes the curve fitter to perform preliminary calculations. For 40 poles and 40 zeros (the default values), these calculations can take over a minute. You can reduce this setup time by reducing the maximum of the poles and zeros bounds. For example, preliminary calculations for the s-domain curve fitter takes about 35 seconds with 10 poles and 10 zeros as the upper bounds.

Select the Source of Data to be Fit

The curve fitters always fit to the frequency response data displayed in trace A, and place the synthesis of the resulting fit model in trace B. If the frequency response data from the last measurement is to be curve-fit, then the **LAST MEAS** softkey can be selected. This selection causes the curve fitter to automatically place the frequency response function in trace A and the coherence function in trace B, replacing any existing trace data. If any math operations are performed on the frequency response data, or the data comes from a source other than the last measurement, then the **A&B TRACES** softkey must be selected. This prevents the curve-fitter from changing the data in traces A and B prior to the start of the curve-fit operation. If an appropriate coherence function is available, it should be displayed in trace B before **START FIT** is pressed. Some math operations produce complex data blocks. The coherence function in trace B must be a real data block, so if you have performed math operations on the coherence function, you may want to use **REAL PART** under **MATH** to produce a real data block. Math operations place a prefix 'M:' on the data type, such as 'M: Frequency Response' or 'M: Coherence.' This prefix is ignored by both the s- and z-domain curve fitters.

Select Auto Order or User Order

If a model with a pre-determined number of poles and zeros is desired, then use the user-order mode. If the order of the model is not known, then use the auto-order mode.

Specify the Sample Frequency or Scaling Frequency

If the z-domain curve fitter is to be used, a sample frequency must be specified before the curve fit is started. The sample frequency can be entered directly into the table, or it can be made to track the measurement sample frequency.

If the s-domain curve fitter is selected, a scale frequency can be entered. By default, a scale frequency of 1 Hz/Hz is used. For example, to obtain an H(s) model with "s" having units of radians, a scale frequency of $1/(2\pi)$ must be entered.

Place X-markers

X-markers can be used to reduce the number of frequency points used in the curve fit. To fit the entire trace, X-markers should be turned off. For more information about X-markers, refer to "The Fit Region".

Note

The LINES 1024 and LINES 801 softkeys do not affect curve fitting.



Starting the Curve Fitter

After the curve-fitter has been properly set up, it can be started using the START FIT softkey in the CREATE FIT menu (see figure 16-7). While the fit is in progress, the **UPPER LOWER** and **FRONT BACK** keys may be used to change the display format.

If you see a fit which you like while the fitter is running, you can press CREATE FIT followed by STOP FIT to abort the fitter. However, only the frequency response synthesis of the curve-fit model in trace B is valid — poles and zeros in the table are usually the values left over from the previous fit (aborting the curve-fitter does not cause pole and zero factoring).

Auto Order Operation

As mentioned earlier in this section, there are two operating modes: auto order and user order. Auto order uses an automated search algorithm; user order does not. The following paragraphs describe the operation of auto order.

When preliminary calculations are finished, the auto-order algorithm starts with an order 1,1 fit (1 pole and 1 zero). The result is placed in trace B, overwriting the coherence. If the fit is not good, the auto-order algorithm does an order 2,2 fit and places the result in trace B, overwriting the order 1,1 fit. The orders are displayed in the lower right corner as the fit order increases.

When a good fit is found, the auto-order algorithm checks to see if a reduced order may also yield a good fit. This process is called order reduction. Order reduction can lower an order by more than one. If a fit with reduced order results in too large an error, the auto-order algorithm increments the order and tries another fit. The order is repeatedly incremented (to no higher than where the order was before order reduction began) until a good fit is found. If the incremented order yields a good fit, the auto-order algorithm again checks to see if order reduction is possible. This can occasionally cause the curve fitter to repeat two fits. Otherwise, order reduction successively reduces the fit order(s), and then finishes the search process after determining that further order reduction probably won't yield an acceptable fit. Some example sequences for reduction are shown in table 16-1.

Table 16-1. Example sequences for curve-fit order reduction

Example 1	Example 2
(poles,zeros)	(poles,zeros)
5,5	6,6
5,3	6,1
5,1	6,2
complete	6,3
	6,2
	6,3
	complete

When the auto-order algorithm finishes order reduction, it factors the polynomial-ratio fit into poles and zeros. Then a search is done on the pole and zero terms to determine if any are close enough to each other to be cancelled. If terms can be cancelled, the new order is briefly displayed in the lower right corner before being written over with 'Fit Complete', and the result display (trace B) is updated with a synthesized transfer function from the remaining poles and zeros. The poles and zeros remaining after cancellation (or all the poles and zeros from factoring if no cancellation occurs) are placed in the curve-fit table along with the gain found. The message 'Fit Complete' indicates that curve-fitting is done, and that the curve-fit table may now be displayed by pressing EDIT TABLE.

If you want to have the frequency response in trace A overlaid with the fits as the order increases, wait 5 seconds after pressing START FIT (the wait is necessary if you use LAST MEAS, since it activates UPPER LOWER at the beginning of a fit) and press FRONT BACK.

Note



The number of poles and zeros found from an auto-order curve fit are not indicated by the numbers at the top of the curve-fit table. Those numbers are the system bounds entered using NUMBER POLES and NUMBER ZEROS. The number of poles or zeros obtained in the fit is determined by counting the entries listed in the table. Complex poles (or zeros) constitute a pair.

User Order Operation

The following paragraphs describe the operation of user order.

After initial calculations are completed, the curve-fit routine uses your system order entries to find a curve-fit model with a frequency response which comes as close as is possible in a least-squares sense to the measured frequency response. No search for an optimal fit is performed; no pole zero cancellation checks are performed. User order simply displays the message 'Fit Complete' along with the results in trace B when it is finished. Factored poles and zeros are placed in the curve-fit table along with the gain found.

If you have good data (coherence is greater than .9995 on average) and you overspecify the system order, the message 'May be Inaccurate' may appear. Some table values may therefore be inaccurate. If this message appears, you should abort the fit (or wait until the 'Fit Complete' message appears) and try another user-order curve fit with a lower order for the numerator and denominator. Keep lowering the orders until a fit can be performed without the 'May be Inaccurate' warning appearing.

View the results

After the curve fit has finished, trace B contains the synthesized result of the curve fit. To view the curve fit table, press EDIT TABLE.

Note



In the s-domain table, unstable poles are indicated by a positive real coefficient. For the z-domain table, unstable poles (which lie outside the unit circle) are highlighted. Occasionally, a 1.0 is highlighted, indicating that extra precision not displayed has placed the pole just outside the unit circle.

Note



When using the curve fitter, here are some things you should be aware of:

- All filtered-input displays are corrupted by the curve fitting operation (filtered-input displays are those in the **MEAS DISP FILTRD INPUT** menu).
 - For measured frequency response data with a 0 Hz start frequency (or within one frequency bin of 0 Hz), the first two frequency bins in the measured data are not included in the fit. The first two bins in trace B are given a linear magnitude of 0.0 (log magnitude of -780 dB). The first two bins in an auto-weighting function are also set to 0.0.
-

Basic Example: s-Domain Curve Fit

This example uses the s-domain curve fitter to find a model for a synthesized frequency response trace. The model obtained by curve fitting to synthesized data is usually quite similar to the model used in the synthesis. This is to be expected, given the high quality of the synthesized data. Unlike measured data, the synthesized data is essentially noise free and representative of a perfectly linear system.

This example uses the s-domain synthesis example used in chapter 17. Refer to “s-Domain Exercise: Pole-Zero Data” in that chapter for entering and synthesizing this frequency response. The data from that exercise is used in this curve fit example. When you have finished the chapter 17 exercise, you should have the trace shown in Figure 16-1.

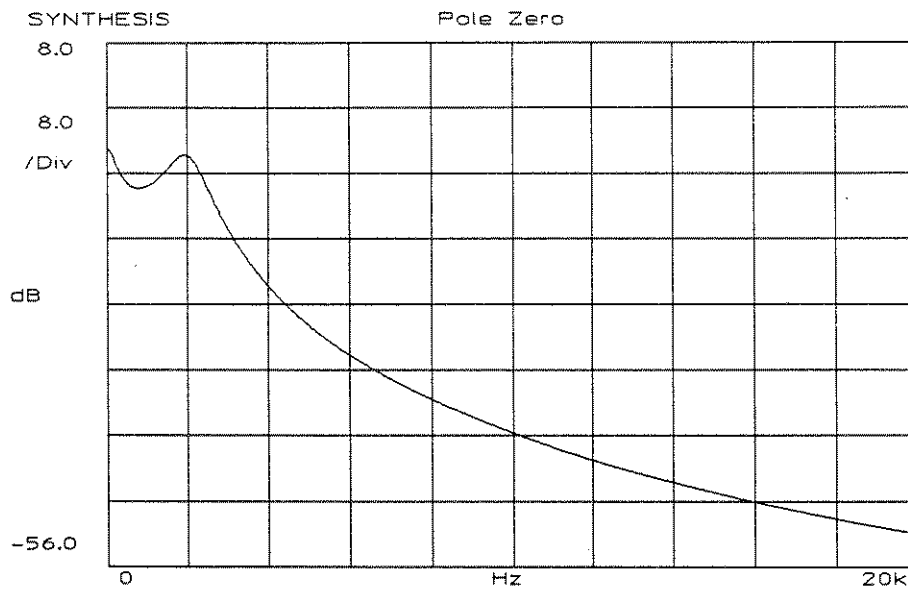

Figure 16-1. Example s-Domain Frequency Response
 Used for s Curve Fit

Curve Fit

Basic Example: s-Domain Curve Fit

Next, make sure X-axis markers are off (they are ON if the yellow LED above **X** is lit). If necessary, press **X OFF** to deactivate the X-axis marker(s). Then press the following keys:

CURVE FIT	Displays the main curve-fit menu
DOMAIN S Z	Toggle this key to the s domain (so that S is highlighted)
NUMBER POLES	Prompts you for the denominator order
5	Press ENTER to complete numeric input
NUMBER ZEROS	Prompts you for the numerator order
5	This will be an auto-order fit. Thus, the auto-order algorithm searches up to a maximum system order of 5 poles and 5 zeros.
A&B TRACES	Instructs the curve fitter to use the frequency response data in trace A and the coherence (if available) in trace B.
FIT FCTN	Displays the fit-function menu
AUTO ORDER	This is the default mode of curve fitting. It instructs the auto-order algorithm to find a good pole-zero model for the frequency response data in trace A, up to the maximum system orders set by NUMBER POLES and NUMBER ZEROS softkeys.
AUTO WEIGHT	Instructs the curve fitter to create a weighting function from the frequency response data (default mode).
RETURN	
EDIT TABLE	
TABLE FCTNS	
TIME DELAY	Make sure this parameter is 0.0 Seconds
SCALE FREQ	Make sure this parameter is 1.0 (Hz/Hz)
RETURN	
RETURN	
CREATE FIT	Displays the create-fit menu. This does not start the curve fit.
START FIT	Starts the curve fit. Notice that you are returned to the main curve-fit menu. If you want to abort the fit, press CREATE FIT followed by STOP FIT .
	 <i>Wait about 5 seconds</i>
FRONT BACK	Shows the curve-fit results in trace B overlaid with trace A frequency response during auto-order search.

When the fit is finished, the message 'Fit Complete' is displayed. The resulting display should look like figure 16-2. Notice the Fxd Y indication in the lower left corner. This indicates the y-scale is fixed to 0, -80 dB on trace B (trace A has the same indication, but it is on y default scale). Remember to change the y-scaling for traces A and B using **SCALE** for future displays (to Y AUTO SCALE or Y DFLT SCALE).

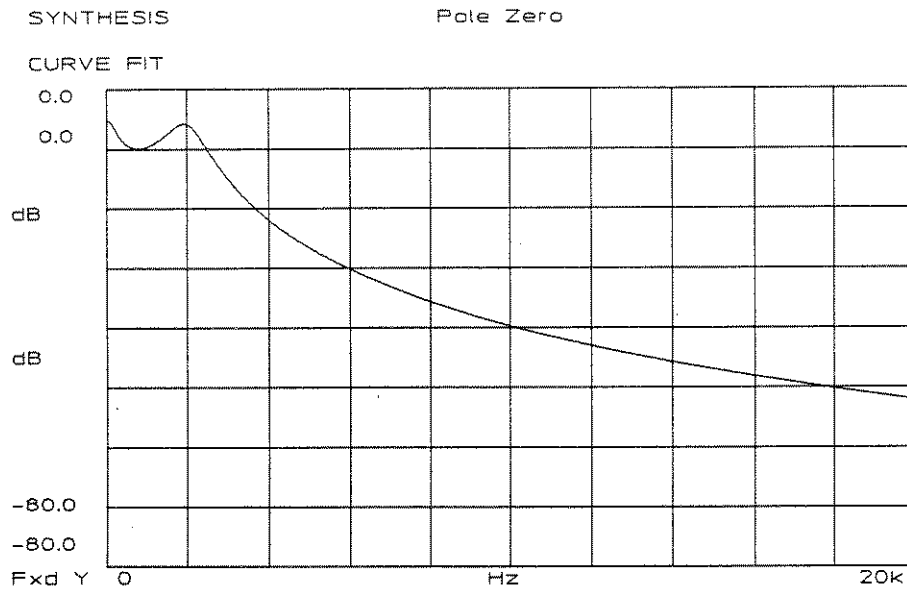

Figure 16-2. Example s Curve-Fit to an s-Domain Synthesis

Curve Fit
Basic Example: s-Domain Curve Fit

You can now edit the curve-fit table by pressing **CURVE FIT** followed by **EDIT TABLE**. Your table should look like figure 16-3.

S Curve Fit				
	POLES		ZEROS	
1	-250.0		600.0	
2	-500.0 ± j	2.0k		
Time delay= 0.0 S		Gain= 1.0M		
Scale Frequency= 1.0				

Figure 16-3. Example s Curve-Fit Table for Figure 16-2

When to Use Auto Order or User Order

If you know your system order ahead of time, you can specify the number of poles and zeros and perform a user-order curve fit. For example, if you want to model your system with two poles, and no zeros, enter 2 for the denominator order (NUMBER POLES), and 0 for the numerator order (NUMBER ZEROS) and perform a user-order curve fit. User order will create a 2 pole, 0 zero model that is as close as is possible (in a least-squares sense) to the measured frequency response.

A model for the system you are measuring is ideal, however, and the real system may have resonances or other parameters that correspond to additional poles and zeros. Consequently, you may need to allow for higher orders in your curve fit model. Thus, beginning with an auto-order curve fit with upper bounds on the system order set several orders (3 or 4) above where you think a reasonable order exists for your system, allows the auto-order algorithm to automatically find a linear model which comes close to your measured frequency response. You will find that if nonlinearities exist in the measurement, the curve fitter will try to find extra poles and zeros to give a response to closely approximate the effects of nonlinearities on the frequency response.

Typically, you want your model to contain a small number of poles and zeros in order to be practical to work with. Thus, if measurement nonlinearities cause the curve-fit orders to climb unacceptably high, you may want to either lower your system bounds and start the auto-order curve fit over again, or return to user-order curve fitting.

User order is useful when auto order returns an unsatisfactory model. For example, the auto-order fit may increment the system order beyond a point at which you feel the accuracy of the fit has become acceptable (you can visually check the accuracy of the fits during curve fitting by pressing **FRONT BACK** several seconds after the curve fit is started). If this happens, you can set the system orders at the point where you saw a good fit and perform a user-order fit to find that model. Afterwards, you can try lower numerator orders with user order as a way of manually doing order reduction.

Note



Remember, the auto-order algorithm is essentially an expert system that uses the curve-fit routine as a tool to try and find a good answer. When auto order does not provide an acceptable answer, you can turn to user order and use the curve-fit routine directly to experiment with different system orders until you find a reasonable model.

Obtaining a Good Model

The fundamental assumption in curve fitting is that the measured frequency response corresponds to a finite-order rational-polynomial (linear) model. There are several challenges involved in making accurate measurements which fulfill this assumption, and in utilizing measurements inevitably subject to contamination and finite frequency span to obtain reasonable models.

Data Errors

There are four basic sources of data errors in frequency response measurements that prevent any curve-fit algorithm from easily finding a linear model:

- Nonlinearities
- Noise
- Quantization Errors
- Digital Overflows

Nonlinearities

Frequency response measurements on systems that are either all-analog, or contain analog subsystems (such as in sampled data systems), may be contaminated by distortion products introduced by system nonlinearities. This contamination can cause the auto-order algorithm to search for sufficiently high system orders to compensate for these errors in the fit model. For example, although a measured system may contain only 4 poles and 3 zeros, errors may perturb the frequency response enough to look like a system with 10 poles and 10 zeros. In other words, there is no way in which the auto-order algorithm can differentiate between measurement errors and correct data (user order will also do its best to fit measurement errors with the numerator order and denominator order you set).

Measurements using the linear resolution mode and logarithmic resolution mode are based on the Fast Fourier Transform (FFT). Broadband stimuli are used for FFT-based measurements. There are two different types of broadband stimuli used in this analyzer:

- Random noise
- Periodic chirp.

If a truly random source is used (that is, RANDOM NOISE or BURST RANDOM), nonlinearities will cause distortion products to randomly appear across the measurement span. Therefore, averaging reduces the effects of nonlinearities on the frequency response measurement, and results in a linear least-squares estimate of the system frequency response.

When using the RANDOM NOISE source, a Hanning window must be applied to the time-domain data to reduce leakage in the frequency domain. However, multiplication in the time domain corresponds to convolution in the frequency domain. This means that the frequency response is convoluted with the fourier transform of the Hanning window, which produces slight frequency smearing (the main lobe of the window is approximately three bins in width). This frequency smearing can affect measurements on systems with sharp peaks in the frequency response — frequency smearing moves resonant poles a little further away from the $j\omega$ axis. Thus, a better measurement results if you use the BURST RANDOM source with SOURCE TRIG and a UNIFORM (NONE) window (burst random is a self-windowing stimulus when source trigger is used).

The other broadband source offered is PERIODIC CHIRP (Periodic Chirp). This source type is completely predictable in that it provides exactly the same stimulus from one measurement to the next. Thus, nonlinearities produce the same distortion products with each average. Consequently, averaging is of no value in reducing the effects of nonlinearities when a periodic-chirp source is used. In addition, the periodic-chirp source makes coherence very high, giving a false impression of a good measurement when nonlinearities may be significant. The periodic-chirp source works best when the system under test is reasonably linear.

One difficulty with using broadband stimuli in some systems is that a signal which is sufficiently strong to provide good signal-to-noise ratios over one portion of the measured span may be too strong for another portion. This leads to a compromise stimulus signal that balances distortion against signal-to-noise ratio.

A third measurement mode, swept sine, is available to provide a solution to this problem. Stimulating the system with a sine wave allows for control of the signal level at a single frequency (rather than broadband noise) over the frequency response measurement. The AUTO GAIN feature can be used to automatically adjust the source level, as the sweep progresses, to maintain a constant reference level on one of the input channels. Typically, the input channel chosen as the reference is the channel connected to the output of the system under test. With this configuration, the output of the system is held constant rather than the input. This reduces the overall level of distortion while maintaining the signal-to-noise ratio.

The swept-sine algorithm tends to reject distortion products (harmonics) caused by system nonlinearities. However, nonlinearities can also cause errors in the measurement of the fundamental frequency (the frequency of the source sine wave). One symptom of measurement nonlinearities that can be observed using the auto-order mode of the curve fitter, is a failure of the curve fitter to stop incrementing system orders after the fit appears to be very good. This can occur on FFT based measurements as well.

Another way to check for nonlinearities is to stimulate the system with a fixed frequency sine wave (in linear resolution or swept sine measurement modes) and observe the linear spectrum in the response channel. If harmonic distortion is evident in the spectrum, then the system contains some form of nonlinearity.

Curve Fit Obtaining a Good Model

In summary, swept sine is best used in situations where a high signal-to-noise ratio cannot be obtained without introducing distortion. The FFT based measurements tend to be faster, and have the advantage of generating a coherence function (coherence is generated in swept-sine measurements, but is not used). With the random source types, the effects of nonlinearities can be averaged out. This is not true of the chirp source types which typically provide better signal to noise ratios. Both the burst chirp and burst random source types are self-windowing, provided source triggering is enabled.

Noise

Noise causes measurement errors. As in the case of distortion products, the curve fitter cannot differentiate measurement errors introduced by noise from correct data. The effects of noise on FFT-based measurements can be minimized by averaging measurements, or for swept sine measurements, by using longer integration times. This assumes that the noise source is uncorrelated to the stimulus (source type) used.

To completely remove errors due to unwanted noise and nonlinearities would theoretically require an infinite number of averages. Since this is not practical, you must choose a compromise. Thus, some error is always present. Averaging reduces the variance of each point in the frequency response measurement as the number of averages increases. The curve-fit routine uses coherence (coherence is calculated from the tri-spectrum averaging process) and the number of averages to calculate the variance on the measurement. The variance is then used as an estimate of the mean error on the measured transfer function. This information is used to improve the accuracy of curve fitting in the presence of noise. Additionally, the auto-order algorithm uses the calculated measurement variance to determine how close the curve fit must come to the measured frequency response to be considered a 'good' fit. See "How Coherence is Used in Curve Fitting" for additional information.

Quantization Errors

Quantization error, which is better described by the term "quantization distortion" than by "quantization noise", is present in any digital system. The effects of noise and distortion on the curve fitter have already been described. To minimize the effects of quantization error, the maximum dynamic range of the system should be utilized in the measurement. For example, driving the input of an A/D converter at only half of full scale wastes dynamic range (about 6 dB in this example). The effects of quantization can also be minimized through source selection. The random source types, random and burst random, generate quantization errors that are relatively uncorrelated to the stimulus. With these source types, averaging can be used to decrease the effects of quantization errors on the measured data. The number of bits used in your A/D converter (and D/A converter) determines the limitation on how much dynamic range can be obtained by averaging: the theoretical limit is approximately 6 dB of dynamic range per bit.

Digital Overflows

Avoid mathematical overflows in digital systems. Overflows can cause clipping or wraparound errors which result in considerable distortion. Use a fixed sinewave and a linear spectrum display to check for this distortion at the output of a digital system. Severe distortion is usually visible in the time domain data as well.

Accounting for Response Outside Measurement Span

s Domain

Curve fitting in the s domain is performed over a finite portion of the theoretical frequency response. This can cause the s-domain curve-fit routine to introduce unexpected poles and zeros. These extra terms (frequently zeros) are necessary to account for the poles and zeros in the system beyond the measurement frequency span that have a significant effect inside the measurement span. For example, a typical op-amp has an open-loop response that begins to roll-off between 10 Hz and 100 Hz due to a single pole. Closing the loop pushes this roll-off farther out (for example, to 150 kHz). Thus, an active filter may be designed to have two poles, but is actually affected by another pole farther out, which may be accounted for in a curve fit depending upon the auto-order curve-fit error tolerance (determined by the measurement variance) in conjunction with the size of the effect.

z Domain

Curve fitting in the z-domain usually involves fitting the frequency response from 0 Hz to $F_s/2$ (F_s is an abbreviation for the sample frequency), which uniquely describes the entire frequency response (the amplitude response of a digital system is mirrored about $F_s/2$, and is periodic about F_s). However, fitting to a digital measurement in which the span is smaller than 0 Hz to $F_s/2$ may require the z-domain curve fitter to introduce unexpected poles and zeros in the same manner as in the s domain.

The Fit Region

Curve fitting is always done over a finite range of frequencies. This is referred to as the fit region. The entire frequency response trace displayed on the analyzer is used as the fit region if X-markers are not turned on. Otherwise, the region between the markers (and including the marker frequencies) is used as the fit region. The curve fitter (whether in auto order or user order) attempts to match the measured frequency response in the fit region. The behavior of the frequency response of the curve-fit model outside the fit region depends upon whether the fit is in the s- or z-domain.

X-markers are useful when a fit over the entire frequency response trace does not provide an acceptable fit over some part of the response. For example, the fit may be very good about a sharp resonance, but may begin to diverge from the measurement as the response dips into higher noise regions. If this region is important, you can use X-markers to restrict the fit region to that portion of the measurement trace where you need a closer match between the fit and the measurement. If this still doesn't provide a good fit, auto weight may not be sufficiently emphasizing the region of importance. In this case, use **USER WEIGHT** to emphasize the region of importance. Assign a value such as .5 to the weighting function between the X-markers. The region outside the X-markers is assigned a value of 0.0, whether **AUTO WEIGHT** or **USER WEIGHT** is used.

Note



A single X-marker results in a fit region of 41 bins in width, centered about the X-marker. This can be useful if you are trying to identify a single resonant peak in the frequency response. A resonance can also be identified (in the s domain only) by using **FREQ & DAMP**, under **SPCL MARKER**.

The following sections discuss the behavior of the curve fit outside the fit region and the use of markers when working with the z-domain curve fitter.

S-Domain Fit Region

The auto-order algorithm finds only those poles and zeros needed to provide a good match to the measurement over the fit region. Thus, the frequency response of the curve-fit model outside the fit region tends to follow the behavior of the response near the boundaries of the fit region. Simple poles or complex-conjugate pole pairs (or zeros) can be found outside the fit region if the actual poles and zeros outside the fit region significantly affect the response inside the fit region. Complex-conjugate pairs found outside the fit region are not underdamped.

The behavior of the curve fitter when terms exist outside the fit region can be demonstrated by entering the table shown in figure 16-4 (note the gain of 1E10), following the same approach as in the s-domain synthesis example used in chapter 17. Refer to "s-Domain Exercise: Pole-Zero Data" in that chapter for entering and synthesizing this frequency response. Synthesize over a 20 kHz span using 801 lines (the internal sample rate of 256 kHz is needed to make this span available under **FREQ**).

S Synthesis			
	POLES		ZEROS
		4	1
1	-250.0		600.0
2	-500.0 ±j	2.0k	
3	-40.0k		
Time delay= 0.0 S		Gain= 10.00E+09	
Scale Frequency= 1.0			

Figure 16-4. Example s Synthesis Table for Observing Effect of Limited Fit Region

Curve Fit
The Fit Region

Now, press the following keys to set up the fit region before starting the curve fitter:

- UPPER LOWER** Displays traces A and B in upper/lower format.
- X**
- X VALUE** Places the X marker at the position you specify (in this case, 1.325 kHz).
- 1.325 kHz** Press 1.325 on the numeric keypad, then press the kHz softkey.
- HOLD X LEFT**

Now rotate the marker knob clockwise until Δx reads 1.25 kHz (see the top status display shown in figure 16-5).

Now, go through the same curve fit procedure given in “Basic Example: s-Domain Curve Fit”, except don’t press **FRONT BACK**. When the auto-order curve fit is finished, you should see a display as shown in figure 16-5.

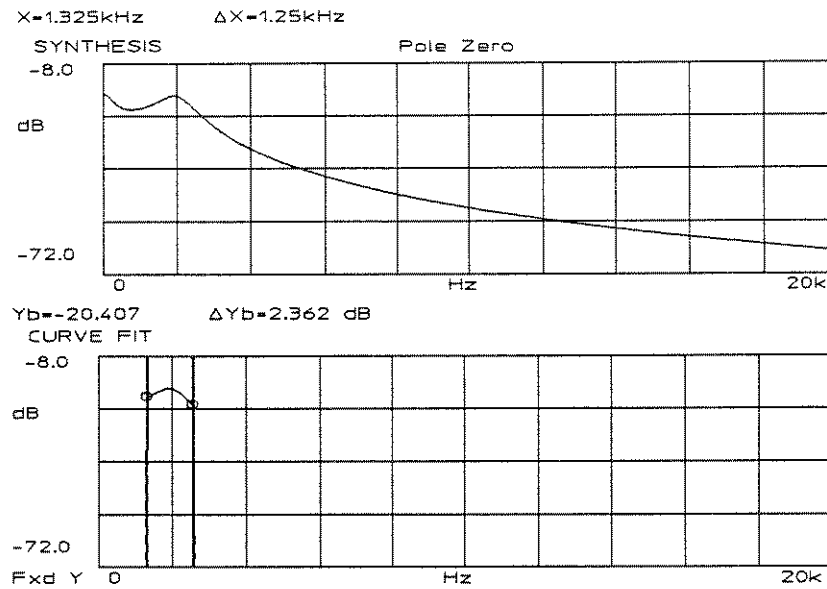

Figure 16-5. Results From an s-Domain Curve Fit Over a Small Fit Region

Notice that the curve fit results are synthesized only over the fit region. The trace outside is at -780 dB (0.0 linear magnitude).

The important point here is that the curve fitter did not find the same model as was in the synthesis table. To see the results, press **CURVE FIT** followed by **EDIT TABLE** — you should see the results shown in figure 16-6.

S Curve Fit				
	POLES		ZEROS	
	S		S	
1	-249.914		599.871	
2	-500.0	$\pm j 1.99997k$	20.3755k	$\pm j 34.9837k$
Time delay-		0.0 S	Gain-	
Scale Frequency-		1.0	152.524 μ	

Figure 16-6. Curve-Fit Table After Fitting Over a Limited Region in the s Domain

Given only a limited picture of the s-domain frequency response, the curve fitter has successfully located the poles and zeros below 5 kHz. The effect of the pole at -40 kHz was small enough inside the fit region that the curve fitter found two additional zeros instead. The additional zeros cause an adjustment of the gain term.

Curve Fit
The Fit Region

It may appear that the curve fitter has given an incorrect answer, but transferring the curve fit table into the synthesis table and re-synthesizing to see the entire response of the curve-fit model demonstrates that the curve fitter provides a good fit given limited information on the frequency response. To see the response of both the original $H(s)$, and the curve-fitted $H(s)$ out to 50 kHz, do the following:

FREQ

FREQ SPAN

50 kHz

Resynthesize original $H(s)$, except now to 50 kHz.

A

SYNTH

CREATE TRACE

S DOMAIN

Perform synthesis in trace A.

B

CURVE FIT

FIT FCTN

FIT -> SYNTH

Transfer curve fit results to s domain synth table.

SYNTH

CREATE TRACE

S DOMAIN

Perform synthesis in trace B.

A & B

SCALE

Y FIXD SCALE

- 10, - 90 dB

Fix the y scaling to be the same for both traces.

Press “- 10, - 90” on the numeric keypad followed by the dB softkey.

You should now see the results shown in Figure 16-7. Observe that the traces match at low frequencies. However, the curve fitter did not have sufficient data to know that the response of the input trace was dropping at -60 dB per decade out at higher frequencies. Thus, an answer with two additional zeros instead, which causes the frequency response to flatten out at high frequencies, works just as well inside the fit region.

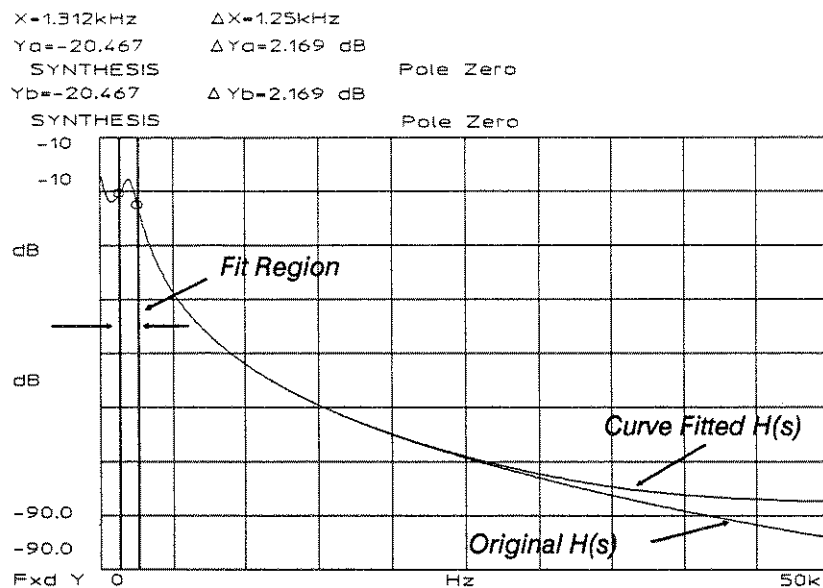

Figure 16-7. Comparison of Original H(s) to Results From Curve Fitting to Limited Region

Z-Domain Fit Region

When using the z-domain curve fitter, markers may be needed to decrease the fit region to a span that is less than half the curve-fit sample frequency (that is, the sample frequency in the curve-fit table; not the sample frequency for the measured or synthesized data). This is necessary because of the periodicity of the model's z-domain response. Attempting a curve fit using a fit region that is greater than $F_s/2$ creates a condition in which the curve fitter attempts to minimize the error between a periodic response and non-periodic data (or data that may repeat with a different period). As an analogy, consider the problems of trying to model a decaying exponential with a sinusoid.

Curve Fitting to Digital Measurements

If the frequency response you want to curve fit to is all-digital (that is, the frequency response is entirely periodic), there are two distinct situations for using the z-domain curve fitter:

- Z-Domain Curve-Fit Sample Frequency = Measurement Sample Frequency
- Z-Domain Curve-Fit Sample Frequency \neq Measurement Sample Frequency

When the curve-fit sample frequency equals the measurement sample frequency, X-markers are not necessary. The results of the curve fitter very closely match the measured frequency response, assuming the data has only a small amount of contamination.

On the other hand, if the z-domain curve-fit sample frequency does not equal the measurement sample frequency, the z-domain curve fitter will do its best to come up with a transfer function with a new periodicity (defined again by the curve-fit sample frequency) that closely matches the measured frequency response over the fit region. However, the fit region must not extend beyond half the curve-fit sample frequency. Thus, you must use X-markers if the curve-fit sample frequency is set below the measurement sample frequency in order to restrict the fit region to frequencies below half the curve-fit sample frequency.

A key point here is that when the curve-fit sample frequency is different than the measurement sample frequency, a finite-order rational polynomial in the z domain no longer represents a valid model for an exact curve fit. In fact, from the point of view of the curve fitter, your measurement may as well have come from a continuous system. At best, you can only obtain a z-domain curve-fit model which approximates the measured frequency response.

To illustrate these points, set the frequency span to 10 kHz (use **FREQ**) and synthesize the z-domain example used in chapter 17. Refer to "z-Domain Exercise: Pole-Zero Data" in that chapter for entering and synthesizing this frequency response (do not use 20 kHz for the span as is used in chapter 17; be sure you use 801 LINES).

When you have performed the exercise in Chapter 17, you should have the trace shown in figure 16-8 (you may need to refer to the s-domain pole-zero exercise in chapter 17 if this is your first time entering a synthesis table).

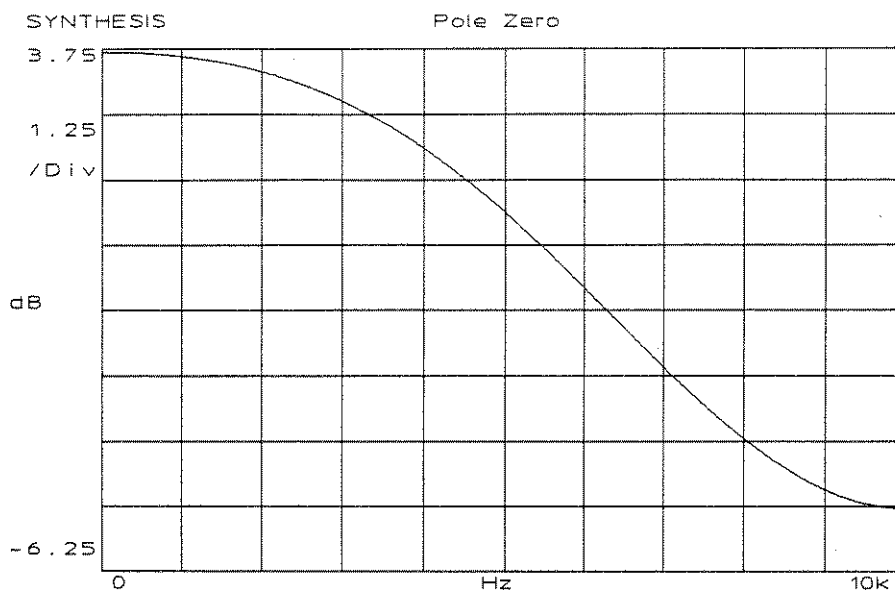

Figure 16-8. z-Domain Synthesis of a Digital Frequency Response out to Half the Sample Frequency for Which the Filter is Designed

Curve Fit
The Fit Region

Following steps similar to those in "Basic Example: s-Domain Curve Fit," perform the following with X-markers off:

CURVE FIT

DOMAIN S Z Toggle this key to the z domain (so that Z is highlighted)
NUMBER POLES
 3
NUMBER ZEROS
 3 We'll use 3 for both orders (we know that 2 is the highest order involved).
A&B TRACES
FIT FCTN
 AUTO ORDER Make sure this is highlighted
 AUTO WEIGHT Make sure this is highlighted
 RETURN
EDIT TABLE
 TABLE FCTNS
 TIME DELAY Make sure this parameter is 0.0 Seconds
 SAMPLE FREQ Highlights this softkey and prompts for user input.
 20 kHz
 RETURN
 RETURN
CREATE FIT
START FIT

Wait about 4 seconds

FRONT BACK

When the fit is finished, 'Fit Complete' is displayed. Press EDIT TABLE to view the z-domain curve fit table. Observe that the table entries are very close to those of the synthesis table. This is the case of z-domain curve fitting when the curve-fit sample frequency equals the measurement sample frequency (we used synthesis to get a digital frequency response for convenience).

Now suppose your goal is to come up with a new digital filter operating at 16 kHz, whose frequency response matches trace A up to 8 kHz. A new sample frequency requires a new curve-fit model (running the original $H(z)$ at 16 kHz instead of 20 kHz simply scales the frequency response down to 16 kHz).

As a first attempt, perform the following:

CURVE FIT

EDIT TABLE

TABLE FCTNS

SAMPLE FREQ

16 kHz

Now design a z domain model to run at 16 kHz and still match trace A

X

X VALUE

0 Hz

HOLD X LEFT

Marker Knob

Rotate the marker knob clockwise until Δx reads 8 kHz (see top display line in Figure 16-9)

CURVE FIT

CREATE FIT

START FIT

When the fit is finished, you should see the display shown in figure 16-9.

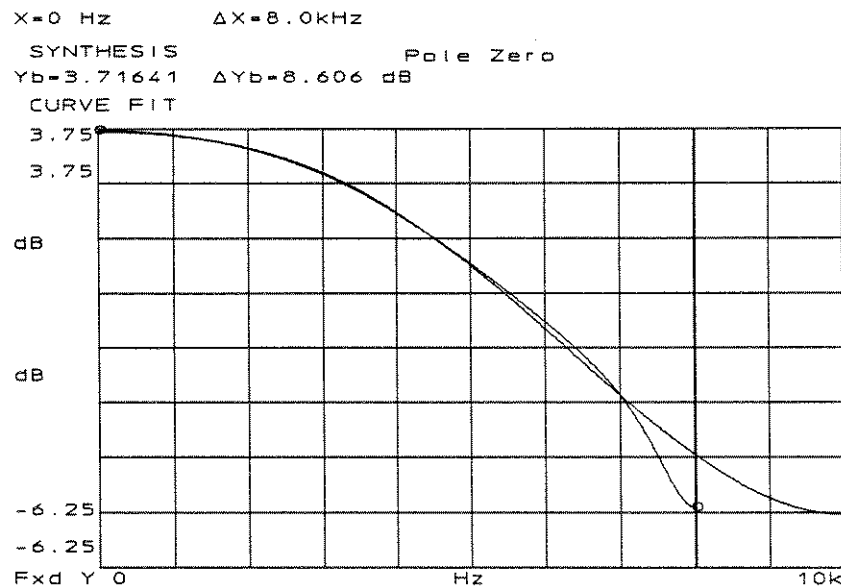

Figure 16-9. Curve Fit With a 16 kHz Sample Frequency and a Fit Region up to Half the Curve-Fit Sample Frequency

The fit comes close to the original model, and diverges near half the curve-fit sample frequency. Unlike the previous fit, which stopped at the original order of 2 poles and 1 zero, the new model required the maximum order set by the system bounds, 3 poles and 3 zeros (if these had been higher,

Curve Fit
The Fit Region

the fit would have climbed still higher in order). This illustrates the important concept of no longer having an exact $H(z)$ rational polynomial model when the curve-fit sample frequency is set to some value other than the one used for the measurement.

Edit the new z-domain curve-fit model. You should see the table shown in figure 16-10.

Z Curve Fit				
	POLES	3	ZEROS	3
1	-1.42226		-17.0954	
2	10.7097m + j ±142.216m		-1.26694	
3			-216.229m	
Time delay = 0.0 S		Gain = 74.3959m		
Sample Frequency = 16.0kHz		+Zpower		

Figure 16-10. Curve-Fit Table with 16 kHz Sample Frequency and a Fit Region up to Half the Curve-Fit Sample Frequency

Observe that the pole in line one is highlighted. This is a feature which automatically indicates whether a pole is outside the unit circle (by computing the square root of the sum of the squares of the real and imaginary part of the pole). This is an unstable, and therefore unusable digital filter design.

This curve could just as well have been generated from an s-domain synthesis (or measurement). Thus, using the curve fitter to find a digital replacement for an analog filter faces the same difficulties.

Finding a stable digital filter which still provides a reasonable match is not hard to do. These two steps provide success in finding a stable model:

1. Reduce the highest frequency of the fit region to below half the curve-fit sample frequency. The farther the better, in terms of finding a stable fit. Of course, the tradeoff is that a smaller portion of the original transfer function is matched.
2. Restrict the maximum number of poles (set the maximum number of zeros equal to the number of poles) to the number of stable poles found in the higher order, but unstable design.

Thus, as a second attempt, do the following:

CURVE FIT

NUMBER POLES

2

The number of stable poles found in the previous fit

NUMBER ZEROS

2

To keep the filter causal, restrict the number of zeros to be no more than the number of poles

X

X VALUE

0 Hz

HOLD X LEFT

Marker Knob

Rotate the marker knob clockwise until delta x reads 6 kHz (see top display line in Figure 16-11).

CURVE FIT

CREATE FIT

START FIT

Curve Fit
The Fit Region

You should now observe the response as shown in Figure 16-11.

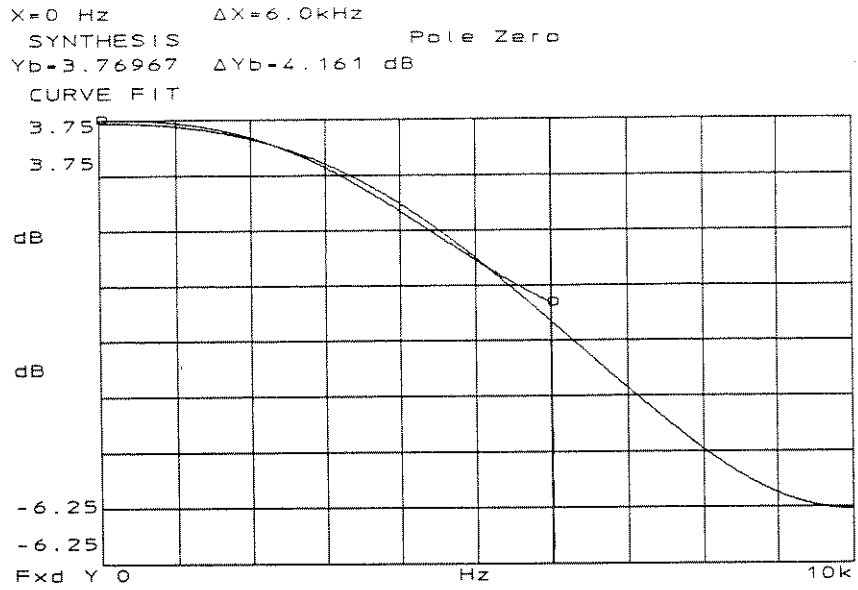

**Figure 16-11. Curve Fit with a 16 kHz Sample Frequency
With Restricted Fit Order and Reduced Fit Region**

The fit is still reasonable inside the fit region, and most important, the curve fit model is now stable. Edit the curve fit table to check this. You should observe the table shown in figure 16-12.

Z Curve Fit				
POLES		2	ZEROS	2
1	122.451m+ j	±186.976m	- 10.5512	
2			42.0148m	
Time delay= 0.0 S		Gain= 112.285m		
Sample Frequency= 16.0kHz		+Zpower		

Figure 16-12. Curve Fit Table With 16 kHz Sample Frequency, With Restricted Fit Order and Reduced Fit Region

his approach is useful for s to z conversions using the z domain curve fitter, and redesigning digital filters to operate at lower sample rates.

If the sample rate is selected to be higher than 20 kHz in this example, the curve-fit model is again an approximation. You may also need to restrict the fit order. Although the fit region is already less than half the curve-fit sample frequency, it may require further restriction using the X-markers.

Z-Domain Curve Fitting to Analog Responses

Performing a z-domain curve fit to an analog response requires the fit region to be restricted to half the curve-fit sample frequency. This problem is identical in nature to a z-domain curve fit to a digital measurement where the curve-fit sample frequency is less than the measurement sample frequency. See the above discussion "Curve Fitting to Digital Measurements" for an example of this case.

Curve Fitting to Mixed Measurements

In a mixed measurement, where one channel is analog (assuming the analog channel is alias protected with respect to the analog channel's sample rate) and the other digital, the frequency response is part periodic and part non-periodic. For example, a D/A converter is modeled as:

$$\frac{1 - z^{-1}}{s}$$

In this example the numerator is a periodic function of s (using the relation $z=e^{-sT}$), whereas the denominator is non-periodic. Neither the s -domain or z -domain curve fitter should be used on this type of frequency response unless the response is made to be all periodic, or all non-periodic.

How Coherence is Used in Curve Fitting

Coherence is a function of frequency. Each frequency point in the coherence function is a real value between 0.0 and 1.0. A value of 1.0 implies that noise does not interfere with the measurement at that frequency. Averaging allows the measured coherence to converge on the true coherence, which is a measure of the noise in the system, not the measurement. Additional averaging gives a better estimate of the coherence and a smaller measurement variance. Thus, as the coherence at a specific frequency converges to a value farther below 1.0, additional averaging is needed to obtain a small measurement variance at that frequency.

The results of either the s-domain or z-domain curve fitter can be improved by reducing the measurement variance across the fit region. As an example, if the average value of the coherence across the fit region is .9995, only 10 averages may be needed to obtain a good fit. However, if the average value of the coherence drops to .95, then 200 averages may be needed for a good fit. There is not a specific relationship between the number of averages and the average value of the coherence needed to obtain a good fit.

Note

Coherence is not used by the curve fitter under any of the following conditions:



- When the data comes from a swept-sine measurement. (Coherence is still displayed if LAST MEAS is selected.)
 - When the data is synthesized.
 - When the measured data is the result of fewer than four averages.
-

How Auto Order Defines a Good Fit

To prevent the auto-order algorithm from always searching to the upper bounds, a variance function is used to establish an error tolerance that gives the auto-order algorithm some margin when fitting contaminated data.

The auto-order algorithm uses the number of averages and the coherence function to calculate a variance function on the measurement. The auto-order algorithm calculates an error-to-signal level, and compares this to a noise-to-signal level. When the error-to-signal level drops below the noise-to-signal level, the fit is defined as good. As a rough approximation, each .9 in the coherence function corresponds to -10 dB in the noise-to-signal level. For example, 0.99 corresponds to a noise level at 20 dB below the signal level, and 0.9999 corresponds to a noise level at 40 dB below the signal level. Since the variance function is used, rather than the coherence function, these figures are merely presented as typical — additional averaging lowers the measurement noise level in the noise-to-signal level calculation.

The curve-fit routine calculates a psuedo coherence when fitting to swept sine measurements. Measurement coherence in swept sine is much higher than obtained with FFT-based measurements. A psuedo coherence allows for a more realistic error tolerance in the presence of nonlinearities.

Effect on Weighting Function

The auto-order algorithm uses the number of averages and the coherence function to calculate a variance function on the measurement. Regions of high variance (low coherence, depending upon the number of averages) are not emphasized in the weighting function when AUTO WEIGHT is used. Also, regions of low variance are not necessarily emphasized: the weighting function only emphasizes regions about peaks, valleys (under some conditions), and frequencies near dc if the variance is low.

The Weighting Function

Like coherence, the weighting function is a real-valued function of frequency which varies between 0.0 and 1.0. The weighting function is used to emphasize important areas of the curve during a curve fit and to de-emphasize areas of high variance. The weighting function can be automatically calculated from measured data, or manually created by the user.

When USER WEIGHT is selected, the curve fitter uses the weighting function created and stored by the user. The user-defined weighting function is usually created by modifying a weighting function created in a previous curve fit using AUTO WEIGHT. When a curve fit using AUTO WEIGHT is finished, EDIT WEIGHT followed by VIEW WEIGHT displays the calculated weighting function in the active trace. This can then be stored with STORE WEIGHT and used in place of an automatically calculated weighting function by selecting USER WEIGHT before performing a new curve fit.

When AUTO WEIGHT is selected and a curve fit is performed on measured data, the curve-fitter automatically derives a weighting function based on an initial estimate of pole and zero locations and on the variance function. The auto-weighting algorithm tends to emphasize low frequencies, peaks, and valleys. Thus, as the frequency increases, the emphasis is on resonances (complex poles) rather than simple poles which may change only the rate of amplitude roll-off.

For synthesized data, the weighing function is not critical to obtaining a good fit, so the auto-weighting algorithm creates a weighting function which has a value of 1.0 at all frequencies (except at 0 Hz).

Under most circumstances the auto-weighting algorithm creates an acceptable weighting function. When the curve fit result doesn't match the measured frequency response in an area that you consider important, it is probably because the auto-weighting algorithm has de-emphasized that portion of the response. In this situation, the best approach to obtaining an acceptable fit is to edit the existing weighting function. Use either the DATA EDIT softkey in the **SPCL MARKER MARKER CALC** menu, or set a region using WEIGHT REGION and WEIGHT VALUE. After re-storing the weighting function, USER WEIGHT should be selected and another curve fit performed.

Fitting Measurements With Delay

Both the s- and z-domain curve fitters can have trouble finding a model when pure delay is present in the measurement.

S-Domain

Any pure delay in a system affects the phase of the frequency response without affecting its magnitude. If these delays are known, they should be entered into the s-domain curve fit table before starting a curve fit. Pure delays cannot be modeled with a finite-order rational polynomial in the s domain. For more information on the effects of excess phase refer to product note HP 3562A-3, "Curve Fitting in the HP 3562A".

Z-Domain

In the z-domain there are two types of delay — partial and full sample delays. As with the s-domain curve fitter, it is best to remove the effects of the delays on the frequency response by entering the delay value into the curve fit table before starting a curve fit. Partial sample delays must be entered as a delay in the curve-fit table. A full sample delay can be entered into the curve-fit table as either a delay, or as a fixed pole at the origin.

Full sample delays can be modeled in the z domain as z^{-n} , where n refers to the number of sample delays. However, noise causes these poles to appear scattered near the origin. Thus, best results are obtained by fixing n poles at the origin.

Example: Curve Fitting to FIR filters

Any z-domain model which contains more zeros than poles is non-causal (since z-domain curve-fit models are only expressed in +Zpower) unless delay terms are added. You should add poles at the origin to make such a design causal. However, the phase then has a linear ramp. Thus, you may want to resynthesize the transfer function.

The product note on z-domain curve fitting mentions FIR filters as an example of a design with more zeros than poles. Note that FIR filters can be thought of as all-zero transfer functions if expressed in negative powers of z. Expressing an FIR filter in terms of positive powers of z produces a pole at the origin with a multiplicity equal to the system order. Thus, in positive powers of z, an FIR filter has an equal number of poles and zeros and does not require extra delay terms to make it causal. Alternatively, the filter can be expressed as the product of z^{-k} (a consequence of the multiple-order pole at the origin), where k is the system order, and an all-zero filter expressed in positive powers of z.

Poles at the origin correspond to unit sample delays (since poles at the origin appear as z^{-k} terms). This delay needs to be taken out of the curve-fit process before curve fitting to an FIR filter by fixing poles at the origin in the curve-fit table (that is, place 0.0 entries in the poles column). If you do not account for delay before curve fitting, poles appear in a scatter pattern near the origin. Larger quantization errors move these farther from the origin.

Fixed Poles and Zeros

When poles or zeros are fixed (using the FIX LINE# key), the curve fitter assumes they are correct and includes them in the next fit. Any pole or zero manually added to the curve-fit table is also tagged as fixed. A fixed term is indicated by an arrow to the right of the term. The fixed line feature allows the results of one curve fit to be included in the results of another. For example, a curve fit could be performed on a narrow region around a resonance. The resonant pole from this fit would be fixed and another curve fit performed on the entire frequency span. Pole and zero locations found in the first fit and set as fixed are retained and used in the second fit. The UNFIX LINE# softkey allows a fixed pole or zero to be replaced in subsequent curve fits.

Curve Fit Setup Steps

These steps are the general procedure for curve fitting. The steps do not have to be performed in the order shown. Steps may be repeated as many times as needed to obtain the best fit.

Step 1: Choose the source of the data

Input data for the curve fitter must be a complex data record. Normally, the curve fitter uses frequency response data, either measured or synthesized. However, any complex data record, such as a cross spectrum, can be fit and is interpreted as frequency response data. If you are using measured data, the measurement may be made in the linear resolution, log resolution or swept sine mode. (Refer to Chapters 3, 4 or 5, respectively, for instructions on making frequency response measurements.)

There are two ways of providing the input data: A & B TRACES or LAST MEAS (both are in the **CURVE FIT** menu). A & B TRACES requires that the frequency response data be in trace A and the coherence data be in trace B. To do this:

Press **A**, then **MEAS DISP**, then **FREQ RESP**

Press **B**, then **COHER**

LAST MEAS uses the last measurement made since power-on as the input to the curve fitter, regardless of the current display. The curve fitter automatically displays the measurement frequency response and measurement coherence. Thus, whatever is in the traces is lost unless it is one of the measurement data records. For example, if a synthesis trace was present, LAST MEAS writes over it and you must repeat the synthesis.

Use **SAVE RECALL** to recall measurement data from either internal data banks (1-5) or disc, and A & B TRACES to curve-fit any measurement not in measurement memory (the data banks 1-5 are not the measurement memory).

Step 2: Choose the Domain (s or z)

Curve fitting may be done in the s or z domains. For this step, press **CURVE FIT** and toggle **DOMAIN S Z** to the correct domain. For example, if you want to perform a curve fit in the s domain, toggle **DOMAIN S Z** so that S is underlined and highlighted.

Step 3: Select Auto Order or User Order

There are two different modes of curve fitting. Auto order experiments with successively larger orders in search of a good model. User order finds a model with a frequency response as close as is possible with the numerator order and denominator order specified with NUMBER ZEROS and NUMBER POLES.

Auto order uses the orders specified with NUMBER POLES and NUMBER ZEROS as the upper bounds for the search.

Step 4: Specify the System Order

The system orders have two different uses. In auto order, the system orders represent upper bounds for an auto-order algorithm which searches for a good fit. The number of poles and zeros is entered with NUMBER POLES and NUMBER ZEROS. Note that the number of poles and zeros indicated at the top of the table is the number you entered, not the number found with auto order. The auto-order algorithm in auto order begins with 1 pole and 1 zero and tries a fit using a weighted least-squares fit. It searches upwards until it finds a good fit, then attempts to reduce the orders if the fitter determines that this may produce a lower-order model with a good fit.

In user order, no search is performed; the numerator order (NUMBER ZEROS) and denominator order (NUMBER POLES) is fed to the curve-fit routine and a model with these orders is found using a weighted least-squares fit.

There are several considerations when specifying the system order. If the order is known, selecting USER ORDER and entering the number of poles and zeros results in a faster fit than using AUTO ORDER. Keep in mind that selecting too few poles and zeros reduces the accuracy of the fit. As a general rule, use two poles for each positive peak in the trace, plus several extra to provide for hidden poles. Likewise, use two zeros for each valley in the trace, plus several extra to provide for hidden zeros.

Step 5: Set the sample or scaling frequency

This step is necessary only for z-domain curve fits. A sample frequency is required for z-domain curve fitting (set with the SAMPLE FREQ softkey). A scale frequency is optional for s-domain curve fitting (set with the SCALE FREQ softkey). See the description of these two softkeys in "The TABLE FCTNS Menu" for additional details.

Step 6: Specify Markers

If you do not want to fit the entire trace, set the markers to limit the range of the curve fit. Set the range with the HOLD X LEFT or HOLD X RIGHT softkeys (under the X hardkey). A single marker causes a ± 20 bin fit. If performing a curve fit in the z domain on data from a continuous system, band markers should be used to limit the fit to frequencies below one-half the curve-fit sample frequency. Otherwise, the curve fitter attempts to match the fundamental z-domain response and any images present in the selected span to the continuous response. This results in a less accurate fit over the fundamental portion of the z-domain response.

Note



The region outside the markers is not synthesized in trace B. Data outside the markers has a linear magnitude of 0.0 (-780 dB). To see the complete response after fitting, you may transfer the fit table to the synthesis table by pressing the following keys:

CURVE FIT

FIT FCTN

FIT -> SYNTH Transfers the curve fit table into the synthesis table. The domain transferred is determined by the current curve fit domain.

B

Sets the active trace to B

SYNTH

CREATE TRACE

S DOMAIN (if you want the s domain)
or Z DOMAIN (if you want the z domain)

Notice that the synthesis domain is changed to match the curve fit domain.

Step 7: Add known poles and zeros (Optional)

Edit the curve-fit table to add known poles or zeros. For example, if a continuous system contains an integrator, add a pole at 0 Hz. Fixed terms are indicated by an arrow. Line numbers must be used explicitly to delete these. See the previous description of the EDIT TABLE softkey for additional details.

Note



When transferring a synthesis table to the curve-fit table, all terms are fixed. Fitting to any table when all terms are fixed is a null fit. This is due to the process of removing fixed terms from the transfer function: a transfer function for only the fixed terms is generated, and then divided out of the frequency response in trace A (done internally, so that trace A is unaffected). Then a fit to the reduced transfer function is performed. Fixing all terms leaves the reduced function as a constant. Thus, the original table is simply returned. The idea of fixing terms is to fix only some of the terms believed to be in a partially unknown transfer function.

Step 8: Enter any known delays (Optional)

Enter any known delays with the TIME DELAY softkey. To do this, press **CURVE FIT** followed by EDIT TABLE, TABLE FCTNS, and TIME DELAY. Then enter the time delay. See the description of the TIME DELAY softkey in “The TABLE FCTNS Menu” for additional details.

This should be done if a phase ramp exists in the frequency response in the s domain. This should also be done if a partial sample delay has imposed a phase ramp in the frequency response in the z domain (a phase ramp is non-periodic, and if caused by a partial sample delay, cannot be modeled as z^{-n}).

Step 9: Specify the Weighting Function (Optional)

The value of any portion of the curve can be specified by first identifying it with WEIGHT REGION, and then entering the value with WEIGHT VALUE. You can enter values between 0.0 and 1.0.

Curve Fit
Curve Fit Setup Steps

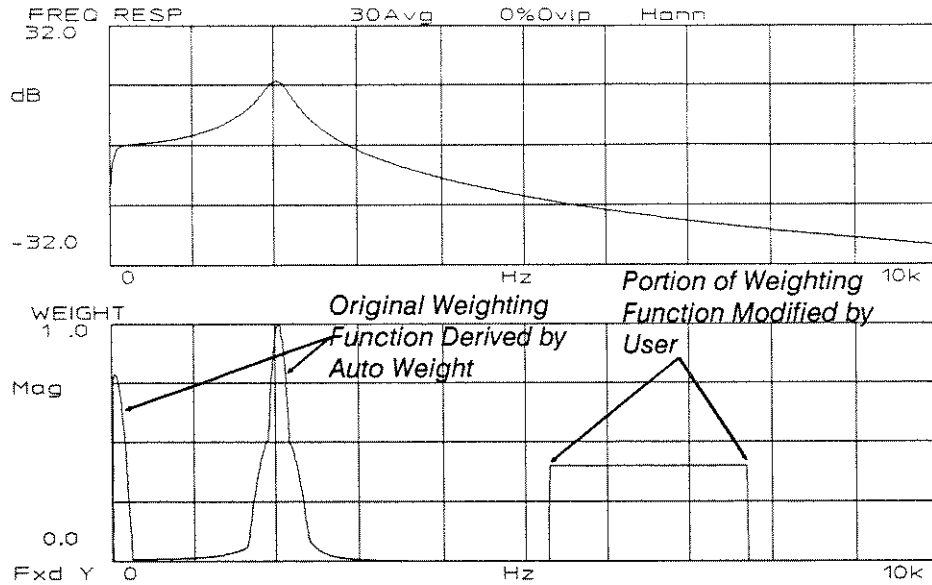

Figure 16-13. User-Modified Weighting Function

The user-defined weighting function must be saved using STORE WEIGHT for the changes to take effect. For example, you can view the weighting function returned from a curve fit using AUTO WEIGHT, modify a portion of the weighting function and then save it in internal memory (used only by the curve fitter for weighting functions) using STORE WEIGHT. You must then change AUTO WEIGHT to USER WEIGHT for your modified weighting function to be used in the next curve fit. You can specify and modify more than one region. Starting a new measurement, or a new curve fit with AUTO WEIGHT, erases your saved weighting function.

Figure 16-13 shows an example of a user-defined weighting function.

Figure 16-14 shows an example of a weighting function where a valley (caused by a conjugate pair of zeros near the $j\omega$ axis) is emphasized by the curve fitter.

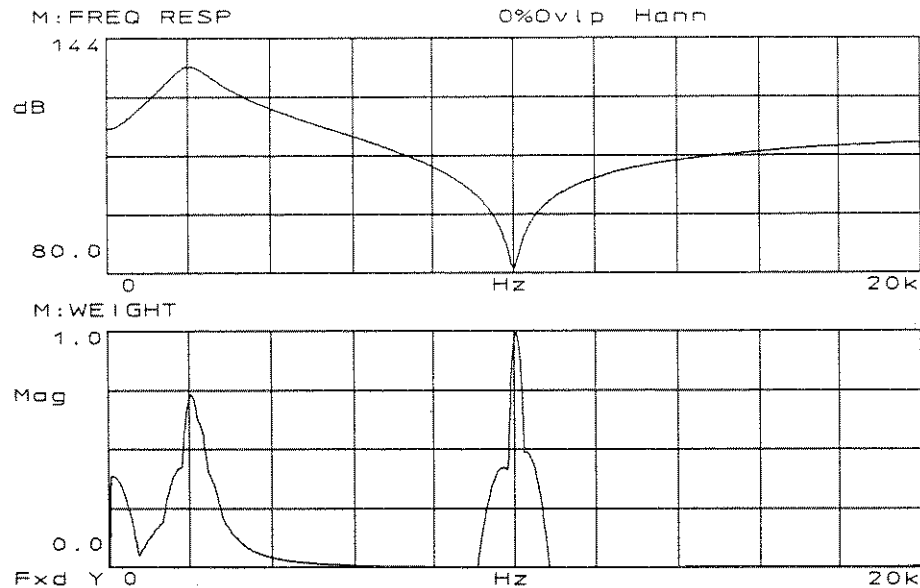

Figure 16-13. Example Auto Weight Emphasizing Both Poles and Zeros

Step 10: Create the Fit

The fit is created when **CREATE FIT** in the **CURVE FIT** menu is pressed. The message “Curve Fit in Progress” is displayed while the fit is in progress. When the fit is complete, the extracted pole and zero locations can be viewed in the curve fit table; press **EDIT TABLE**.

You can fit any portion of the displayed frequency response trace. Use the **X** marker (see Chapter 8 for instructions) to identify the band of interest, then press **CREATE FIT**. The curve is then fitted only inside the marker band.

If an acceptable fit is achieved before the specified number of poles and zeros have been extracted, the fit can be stopped by pressing **STOP FIT**. It is helpful to press **FRONT BACK** while the fit is in progress. This superimposes the measured response and the fit results so you can monitor the progress. The fit can also be stopped if it becomes clear that the setup is inappropriate. Because fitting high-order systems can be time consuming, stop the fit if it is obviously incorrect. The aborted curve fit does not factor the last polynomial fit into a table of poles and zeros — the previous table is left.

Curve Fit
Curve Fit Setup Steps

To judge the accuracy of a fit, view the **FRONT BACK** display when the fit is complete. Because this superimposes the measured frequency response and the curve fit result, it quickly indicates any differences.

Step 11: View and Edit the Curve Fit Table

The curve-fit table, displayed by pressing **EDIT TABLE**, contains the pole and zero locations extracted by the curve fitter. Figure 16-15 shows an example of the curve-fit table. Lines identified with arrows are either set or added by the user, and are fixed during curve fitting.

Pressing **EDIT TABLE** also displays the menu used to edit the table. This menu allows you to alter the pole and zero information to obtain the desired fit. The four editing softkeys (**FIX LINE#**, **UNFIX LINE#**, **ADD LINE#** and **DELETE LINE#**) apply to either the poles or zeros, depending on whether **EDIT POLES** or **EDIT ZEROS** is active.

S Curve Fit						
POLES			6	ZEROS		6
1	-250.015			599.992		←
2	-500.007 ±j	2.0k	←	-99.9834 ±j	10.0k	
Time delay- 0.0 S				Gain- 1.0M		
Scale Frequency- 1.0						

Figure 16-15. The s-Domain Curve-Fit Table with Several Fixed Terms

Key Reference

All of the softkeys used in setting up and performing a curve fit are accessed with the **CURVE FIT** hardkey. Figure 16-16 shows the available softkeys, each of which are described in the remainder of this chapter.

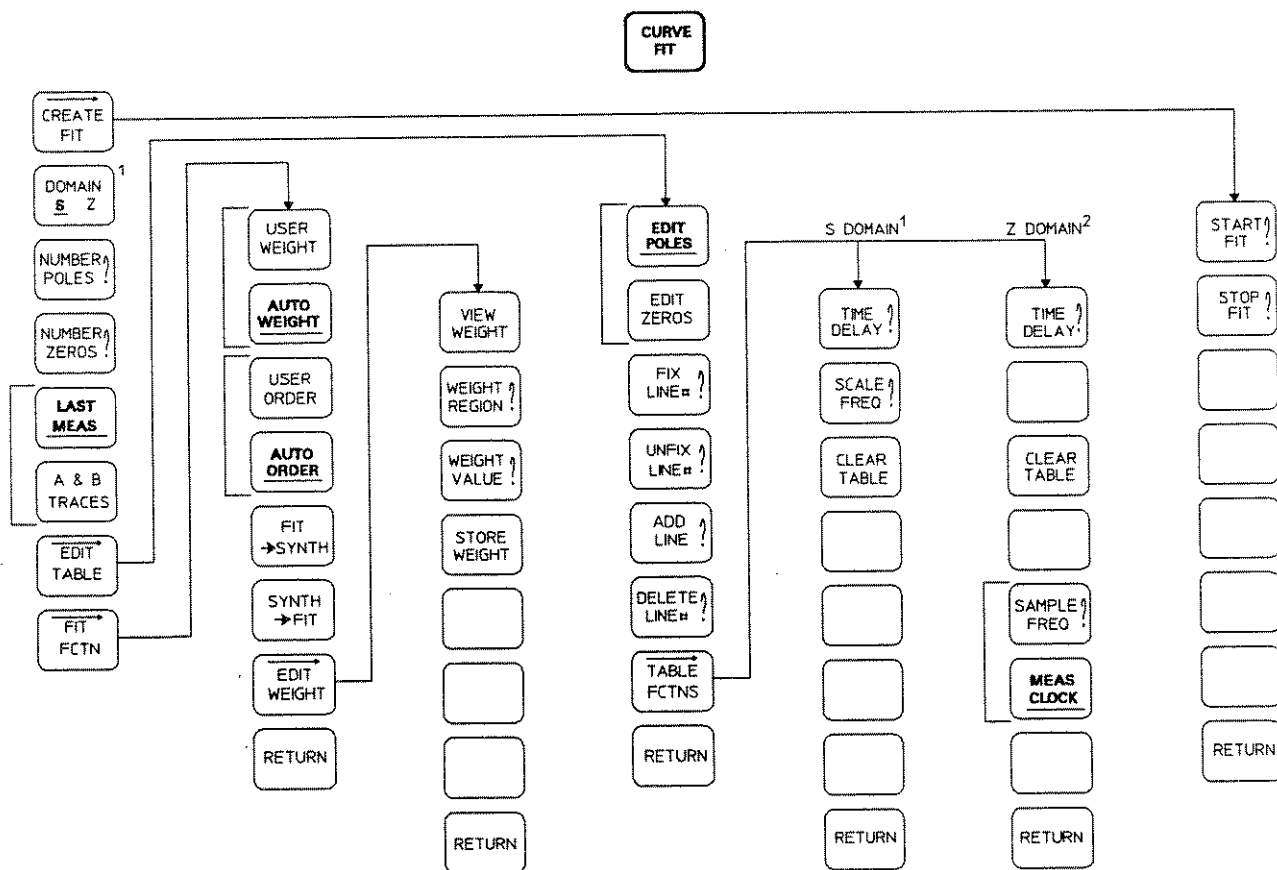

¹ This menu appears when [DOMAIN S Z] is selected.
² This menu appears when [DOMAIN SZ] is selected.

Figure 16-16. CURVE FIT Menu Diagram

The **CURVE FIT** softkeys do the following:

CREATE FIT	Displays another menu that allows you to start or stop a curve fit operation. See “The CREATE FIT Menu” for details.
DOMAIN S Z	Selects between the s- and z-domain curve fitters and their associated tables. Two tables exist at all times: one for the s-domain curve fitter; one for the z-domain curve fitter. The operation of one curve fitter does not affect the other curve fitter’s table. The default selection at power-on or reset is the s-domain.
NUMBER POLES	<p>Used to enter the number of poles, or maximum number of poles, depending on whether USER ORDER or AUTO ORDER is selected. If USER ORDER is selected, then the curve fitter finds a model with the specified number of poles. If AUTO ORDER is selected, the curve fitter finds the optimum number of poles, without exceeding the number you have specified. When AUTO ORDER is used, the number of poles shown in the curve-fit table is the number entered with NUMBER POLES, not the number of poles actually fitted. The value entered must be between 0 and 40 poles. The default is 40 poles.</p> <p>To determine the number of poles in the system after an auto-order curve fit, press the EDIT TABLE softkey and count the entries in the curve-fit table. If an entry is complex, two poles (a conjugate pair) appear on a line; if real, one pole appears on a line. If the system order is unknown, it is best to specify a large number of poles, then use the AUTO ORDER feature in the FIT FCTN menu to determine the actual order.</p>

Note



The auto-order algorithm always starts with one pole, even if NUMBER ZEROS is set to 0.

Thus, when curve fitting in the z domain to an FIR filter, fix poles at the origin, rather than setting NUMBER POLES to 0 and compensating with Time Delay in the curve-fit table.

NUMBER ZEROS	Used to enter the number of zeros, from 0 to 40 (a conjugate pair is considered 2 zeros) — 40 zeros is the default. The actual number of zeros used depends on the order selected, as described for NUMBER POLES.
-----------------	---

**LAST
MEAS**

Selects the results of the last frequency response measurement as the input to the curve fitter. When the curve fit operation begins, trace A changes to display the measured frequency response data. If coherence is available, it is placed in trace B.

Use the A & B TRACES softkey if the measured data is to be modified before a curve fit is started.

Note

The data displayed in traces A and B is lost when LAST MEAS is selected and START FIT is pressed. It is replaced by the data from the last frequency response measurement.

**A & B
TRACES**

Selects the data in the A and B traces as the input to the curve fitter. You must place frequency response data in trace A. You must place a coherence plot in trace B, or else the curve fitter (s and z) calculates a pseudo coherence. Curve fits to synthesized functions ignore trace B and use a default coherence of 1.0.

**EDIT
TABLE**

Displays the table of values resulting from a fit and its editing menu. This allows you to add, delete, or fix or unfix poles and zeros. See "The EDIT TABLE Menu" for additional details.

**FIT
FCTN**

Displays the curve fit functions menu, which is used to specify user/auto weight and user/auto order, transfer synthesis and curve fit tables, and view and edit the weighting function. See "The FIT FCTN Menu" for details.

The CREATE FIT Menu**START
FIT**

Starts the curve fit operation using the current setup. Poles and zeros in the curve fit table which are not fixed are changed (or deleted).

The curve fitter always fits to the function in trace A and places the synthesized result in trace B. Under certain conditions, a coherence function in trace B is used in the curve fit operation. If A & B TRACES is selected, the trace data must be present before START FIT is pressed. If LAST MEAS is selected, the results of the last frequency response measurement is automatically displayed when START FIT is pressed.

**STOP
FIT**

Stops the curve fit. Use STOP FIT if the fit is not converging. The pole and zero values in the current estimate are lost when STOP FIT is pressed. The table will be empty or contain the values from the previous curve fit operation.

The EDIT TABLE Menu

Each curve fit table displays setup information as well as curve fit results. The EDIT TABLE softkey allows you to view or edit the active (s- or z-domain) curve-fit table. You can add, delete, fix or unfix the poles and zeros in the table. If a curve fit has not been performed since power-on or reset, the table is empty. Removing power, or resetting the analyzer erases the table. The curve fit tables are always displayed in pole-zero format. For the z-domain table, positive powers of z are used. To change the format of the table to something other than pole/zero form, it must be transferred into a synthesis table. For more information on transferring tables refer to "The FIT FCTN Menu."

Use the following softkeys to view or edit the curve-fit table:

EDIT POLES	<p>Shifts the editing softkeys to the poles in the curve-fit table. The word "POLES", displayed at the top of the curve fit table, is highlighted to indicate that FIX LINE#, ADD LINE, and DELETE LINE # affect only the poles. If you are editing an empty table, press the ADD LINE softkey. To enter a complex conjugate pair, enter the real value with the Entry group keypad, enter a comma (,) enter the imaginary value, then press one of the unit softkeys. Entered values are fixed.</p> <p>If you are editing an existing table, press the DELETE LINE# softkey to delete the pole on the specified line number. Use the Entry group keypad to enter the number of the line you want to delete and then press ENTER. The z-domain poles outside the unit circle are highlighted.</p>
EDIT ZEROS	<p>Shifts the editing softkeys to the zeros in the curve-fit table. The word "ZEROS", displayed at the top of the curve fit table, is highlighted to indicate that FIX LINE#, ADD LINE, and DELETE LINE # affect only the zeros. If you are editing an empty table, press the ADD LINE softkey. To enter a complex conjugate pair, enter the real value with the Entry group keypad, enter a comma (,) enter the imaginary value, then press one of the unit softkeys. Entered values are fixed. If you are editing an existing table, press the DELETE LINE # softkey to delete the desired line. Use the Entry group keypad to enter the number of the line you want to delete and then press ENTER.</p>
FIX LINE #	<p>Fixes (holds constant) a pole or zero in the curve-fit table, depending on whether EDIT POLES or EDIT ZEROS is active. Fixed poles or zeros are identified by an arrow in the table. For example, to fix a pole press EDIT POLES, FIX LINE#, and enter the line number of the pole to be fixed.</p>

When a pole or zero is fixed, the curve fitter assumes it is accurate and attempts to find a model which includes the fixed term. If poles or zeros are known to exist at the origin, fixing them usually improves the accuracy of the fit. To allow the curve fitter to change a fixed pole or zero, use the UNFIX LINE # softkey or delete the entry with the DELETE LINE # softkey.

UNFIX
LINE #

Unfixes a previously fixed pole or zero in the curve-fit table, depending on whether EDIT POLES or EDIT ZEROS is active. Once a pole or zero is unfixes, it may be changed (or deleted) by the curve fitter in the next curve fit operation. Fixed poles (or zeros) are identified in the table by an arrow on the right side of the column. Fixed pole/zero entries are created when the table is transferred from a synthesis table, when a pole or zero is manually added (using the ADD LINE softkey), or when the FIX LINE # softkey is used.

ADD
LINE

Used to add a pole or zero to the curve-fit table, depending on whether EDIT POLES or EDIT ZEROS is active. The entry is automatically fixed so that it is included in the next curve fit (See "FIX LINE #"). To add a real-only value, enter the value then press one of the unit softkeys. To add a complex conjugate pair, enter the real value with the Entry group keypad, enter a comma (,) enter the imaginary value, then press one of the unit softkeys. Lines are rearranged in ascending frequency after each fit. The location of where a line is added to the table does not impact the curve fit process.

DELETE
LINE #

Deletes a pole or zero in the curve-fit table, depending on whether EDIT POLES or EDIT ZEROS is active. The entry is deleted immediately, and the remaining lines are renumbered. To abort deleting a line after the line number has been entered, press CANCEL instead of ENTER.

TABLE
FCTNS

Displays the table functions menu, which allows you to add time delays and system gains to the curve-fit table. This menu also allows you to clear the curve-fit table. See "The TABLE FCTN Menu."

RETURN

Saves the changes made in the current editing session and redisplay the **CURVE FIT** menu.

The TABLE FCTNS Menu

The TABLE FCTNS softkey displays another menu that allows you to further modify the curve-fit table. The menu displayed is appropriate for selected domain (DOMAIN S Z)

Note



The following softkeys operate the same for both the s- and z-domains, except as noted.

TIME DELAY

Used to enter time delay values. If the system being fitted has an extraneous time delay in its response, this value must be included to obtain an accurate fit. The default value is 0.0 seconds. For curve fit operations in the z-domain, partial sample delays present in the measured frequency response must be entered. Full sample delays present in the measured frequency response can also be accounted for by entering the appropriate number of fixed poles at the origin. Curve fits can be improved by accounting for full sample delays with fixed poles.

Positive delay is entered as a positive value. The delay can be in terms of microseconds, milliseconds or seconds. The time delay can be measured directly using the cross-correlation measurement (see "The Cross Correlation Measurement" in chapter 3). Note that partial sample delays in digital systems cannot be measured using correlation.

The computational delay entered for a digital measurement with the COMPUT DELAY softkey (DATA CLOCK menu under **INPUT CONFIG**) is not added to the time delay value in the table and does not affect the curve fitting operation. If computational delay is used to negate delay in the digital or mixed measurement, then the delay time can be left as 0.0 in the curve fit table.

SCALE FREQ

This softkey is available when the s-domain curve fitter is selected. It allows a scaling frequency to be entered for s-domain curve fits. The scaling frequency is used during a curve fit to re-scale the frequency axis without scaling amplitude.

The frequency can be entered in units of Hz, RPM or Orders. Use the units in which the trace is displayed. The range is 0.00001 to 1,000,000 (the default is 1.0 Hz/Hz). To be used, SCALE FREQ must be set before the curve fit is started.

The scale frequency feature also provides a method for the pole/zero model to be returned in units of radians. To work in radians, enter a scale frequency of $1/(2\pi)$.

The following tables are identical:

Hz	Scale Freq	Gain
Pole at -1	1	1

Radians	Scale Freq	Gain
Pole at - 6.28318	0.159155	6.28

**CLEAR
TABLE**

Allows you to clear the curve-fit table. This erases all values found by the curve fitter, as well as values added or fixed by the user. Clearing the table also resets the system gain to 1.0 and the time delay to 0.0 seconds. After CLEAR TABLE is pressed, the message "Push Again to Clear" is displayed. Press CLEAR TABLE again to confirm your request to clear the curve-fit table. Once cleared, tables cannot be recovered. Before a table is cleared, it can be saved in disc memory; see chapter 11, "Disc/Plotter/HP-IB Operation".

The HP-IB command to clear a table only needs to be sent one time.

**SAMPLE
FREQ**

This softkey is available when the z-domain curve fitter is selected. It is used to enter the sample frequency for a z-domain curve fit. *The sample frequency must be set before the curve fit process is started.*

The curve fit operation requires a sampling frequency to determine the z-domain model. The curve fit sample frequency does not have to match the sample frequency of the measured or synthesized frequency response data. You can specify a sample frequency by entering a value with the SAMPLE FREQ softkey. This sample frequency is entirely independent of any other "sample frequency" used in the analyzer.

The curve fit sample frequency can be made to automatically track the measurement sample frequency by selecting the MEAS CLOCK softkey. In this case a numeric entry using the SAMPLE FREQ softkey is not necessary.

**MEAS
CLOCK**

This softkey is available when the z-domain curve fitter is selected. It provides an alternate method of setting the sample frequency used in the curve fit. When MEAS CLOCK is selected, the sample frequency used by the curve fitter is the same as that used in a measurement. The measurement sample frequency is set under the **FREQ** or **INPUT CONFIG** hardkeys. When the measurement sample frequency is changed, the change is reflected in the next z-domain curve fit performed. It is not necessary to press MEAS CLOCK again.

The FIT FCTN Menu

The FIT FCTN softkey displays another menu that allows you to view and edit the weighting function, select user or auto order, or transfer curve-fit and synthesis tables. The FIT FCTN menu is shown in figure 16-16.

The softkeys in this menu function as follows:

USER WEIGHT	Selects user weighting, which prevents the curve fitter from creating a new weighting function when a curve fit is started. The existing weighting function can be viewed, edited, and stored using softkeys available in the EDIT WEIGHT menu.
----------------	---

Note



The effect of any previously stored weight is removed if a new measurement is made. To save a weighting function for later use, it must be displayed using VIEW WEIGHT and the saved using softkeys in either the **SAVE RECALL** menu or in the **DISC** menu. To use the saved weighting function it must be recalled from memory or disc into a trace and then stored using STORE WEIGHT.

AUTO WEIGHT	Selects auto weighting, which causes the HP 3563A to automatically calculate a new weighting function with each curve fit. Auto weighting emphasizes the high-coherence portions of the curve and de-emphasizes the low-coherence portions. It also tends to emphasize low frequencies, peaks, and valleys.
----------------	---

USER ORDER	Selects user order, which causes the HP 3563A to fit with the number of poles and zeros specified by NUMBER POLES and NUMBER ZEROS. Select USER ORDER if the system order is known and you want the curve fitter to extract a specific number of poles and zeros. AUTO ORDER should be used for the first fit on a system with unknown order.
---------------	---

A better fit can often be obtained with user order if a few extra poles and zeros are allowed. The extra poles and zeros improve the curve fit even though they may end up being coincident in the final result.

AUTO ORDER	Selects auto order, which causes the HP 3563A to select the optimum number of poles and zeros — up to the maximum number specified with NUMBER POLES and NUMBER ZEROS. USER ORDER is faster than AUTO ORDER and should be used if the system order is known.
---------------	--

The default values used for the maximum number of poles and zeros is 40. Some of the preliminary curve fit calculations are based on the specified number of poles and zeros. The time necessary to perform these calculations can be reduced by reducing the maximum number of poles and zeros that can be used by the auto-order algorithm.

Unlike the user-order mode where a single curve fit is performed using a specified number of poles and zeros, many curve fits are performed in auto-order mode — each with a different number of poles and zeros. The auto-order algorithm also attempts to further reduce the order of the system after a good fit has been found.

FIT->
SYNTH

Copies the active curve-fit table (s or z domain) to the appropriate synthesis table. Note that any values already in the synthesis table are erased when the curve-fit table is copied. The curve fit table remains unchanged. The curve fit table is copied into the synthesis table in pole-zero form.

SYNTH->
FIT

Copies a pole/zero synthesis table to the appropriated curve-fit table. Note that any values already in the curve fit table are erased when the synthesis table is copied. All pole/zero entries copied into the curve fit table become fixed. You may want to unfix some of the entries before starting a curve fit.

The only synthesis table format that can be copied into a curve fit table is pole-zero. The message, "Data Blocks Incompatible", appears if you try to transfer a Pole Residue or Polynomial synthesis table. To transfer a Pole Residue or Polynomial table to the curve fitter, first convert the table to Pole Zero format using the CONVRT TABLE softkey (under **SYNTH**), then move the table using this softkey. See the description of the CONVRT TABLE softkey in chapter 17 for additional information about converting tables to different formats.

EDIT
WEIGHT

Displays the edit weight menu, which is used to view, modify and store the weighting function. See "The EDIT WEIGHT Menu" for further details.

The EDIT WEIGHT Menu

The EDIT WEIGHT softkey displays another menu that allows you view, modify and store the curve-fitter's weighting function. The weighting function determines which portions of the trace are fitted with the greatest accuracy. The weighting function varies between 0.0 and 1.0 where 1.0 is maximum weighting.

If USER WEIGHT is selected, the next curve fit operation does not create a new weighting function. Instead, it uses the last stored weighting function saved with the STORE WEIGHT softkey.

If AUTO WEIGHT is selected, a new weighting function is created when the curve fit is started — overwriting the existing weighting function.

The following list of steps outline the procedure for creating a custom weighting function:

1. Press **A** or **B** to select a trace in which to edit the weighting function.
2. Press VIEW WEIGHT to view a copy of the current weighting function.
3. Use WEIGHT REGION and WEIGHT VALUE to modify the weighting function.
4. Press STORE WEIGHT to replace the current weighting function with the weighting function in the active trace.

Note



Storing the weighting function is not a **SAVE RECALL** operation. It does not protect the weighting function from being overwritten by new measurements. See "STORE WEIGHT" for more information on saving a weighting function.

VIEW
WEIGHT

Displays a copy of the existing weighting function in the active trace.

WEIGHT
REGION

Used to specify a portion of the weighting function to be modified by WEIGHT VALUE. Enter the minimum and maximum frequencies separated by a comma. Or, you may want to use the X marker (Markers group) and the **MARKER VALUE** hardkey to enter the minimum and maximum frequencies. In this case, use the X marker to bracket the area of interest in the frequency response measurement. Then, press WEIGHT REGION followed by **MARKER VALUE** to enter both frequencies. Portions of the function outside the weight region retain their original values. More than one region can be modified.

The **SPCL MARKER/MARKER CALC/DATA EDIT** softkeys can also be used to edit the weighting function trace. The DATA EDIT softkey allows a ramp to be created over a portion of the trace. The WEIGHT REGION and WEIGHT VALUE softkeys can only generate constant valued functions over a region.

WEIGHT
VALUE

Used to define the value of the weighting function inside the region identified by WEIGHT VALUE. Press WEIGHT VALUE, then enter the weighting constant, a value between 0.0 and 1.0, for the specified over that region. Any portion of the weighting function outside the region will retain its original value. Regions that have a value of zero will not be used in a curve fit.

STORE
WEIGHT

Replaces the current weighting function with the function displayed in the active trace.

VIEW WEIGHT is used to copy the current weighting function into the active trace. If the trace is modified for the purposes of creating a new weighting function, then the current weighting function must be replaced. This is accomplished with the STORE WEIGHT softkey.

There are two ways to save a weighting function for later use. Use the VIEW WEIGHT softkey to copy the weighting function into the active trace. Then use either the **SAVE RECALL** softkeys to save the trace into a data register, or use the **DISC** softkeys to save the trace into a disc file. For more information on saving and recalling trace data, refer to Chapter 8.

To use a saved trace as a weighting function, it must first be recalled into the active trace and then stored using the STORE WEIGHT softkey. USER WEIGHT should be selected to prevent a new weighting function from being calculated when the curve fit is started.

RETURN

Redisplays the previous menu (see figure 16-16). Note that changes made to the user weighting function are lost if STORE WEIGHT is not pressed before pressing this softkey.

Synthesis

Purpose of This Chapter

This chapter shows you how to use the analyzer's synthesis feature. The synthesis feature enables you to generate frequency-response traces based on an $H(s)$ model, an $H(z)$ model, or the product of both — with or without the effects of a zero-order hold.

This chapter is divided into two parts. The first half shows how to use the synthesis features. The second half is a key reference that contains detailed descriptions of the softkeys available under the **SYNTH** hardkey. Begin with the first half of this chapter to learn the synthesis features. As you read, refer to the key reference if you need additional information.

Note



Synthesis examples and applications are also available in chapter 4 of the *HP 3563A Getting Started Guide*.

Synthesis Overview

Synthesis allows you to create a trace based on the transfer function of a system. Synthesis is set up and controlled using softkey menus under the **SYNTH** hardkey (as shown in figure 17-1). To perform synthesis, you enter parameters from your transfer function into the analyzer's synthesis table. Parameters can be represented in one of the following data formats:

- Pole-Zero
- Partial Fraction (Pole-Residue)
- Polynomial

There are two synthesis tables that exist in the analyzer at all times: one for the s domain and another for the z domain. Both tables are stored in non-volatile memory and are not erased when power is removed. A synthesis table can also be stored in disc memory; see chapter 11 for instructions.

Each synthesis table can have a maximum of 22 lines of data. Since conjugate pole (or zero) pairs occupy one line, pole-zero and pole-residue tables can contain up to 44 poles and 44 zeros.

Entering Data in a Synthesis Table

To enter data in a synthesis table, press **SYNTH** and select the domain with the **DOMAIN S Z** softkey. To work in the s domain (in other words, to enter data in the s -domain synthesis table), toggle **DOMAIN S Z** such that **S** is highlighted. To work in the z domain (in other words, to enter data in the z -domain synthesis table) toggle **DOMAIN S Z** such that **Z** is highlighted. Then press **POLE ZERO**, **POLE RESIDU**, or **POLYNOMIAL** (see figure 17-1). **POLE ZERO** lets you enter pole-zero data. **POLE RESIDU** lets you enter pole-residue data. **POLYNOMIAL** lets you enter polynomial data.

How Analyzer Configuration Affects Synthesis

Analyzer configuration affects the synthesis frequency span and the x-axis data spacing of the synthesis trace. The following sections tell you how analyzer configuration affects synthesis.

Determining the Synthesis X-Axis Spacing

Synthesis data spacing for the x-axis can be either linear or logarithmic. The linear resolution mode produces linear spacing; the log resolution mode produces log spacing. Swept sine mode can produce linear or log spacing: press **MEAS MODE LINEAR SWEEP** to produce linear spacing; press **MEAS MODE LOG SWEEP** to produce log spacing.

Determining the Number of Data Points Generated by the Synthesis

The number of data points generated by the synthesis depends on the measurement mode. In log resolution mode, the synthesis generates 80 points per decade. In swept sine mode, the synthesis generates 801 points. In linear resolution mode, you can select either 801 points or 1024 points for the synthesis (press **WINDOW** followed by 801 LINES or 1024 LINES). If you are making digital measurements and you want to do a z-domain synthesis up to the Nyquist frequency (half the sample frequency), you must select 1024 points.

The frequency span for 801 lines is determined by dividing factors of 1, 2 and 5 into $F_s/2.56$ (F_s is an abbreviation for the measurement sample frequency). The frequency span for 1024 lines is determined by dividing factors of 1, 2 and 5 into $F_s/2$, and then subtracting one frequency bin. For example, suppose your measurement sample frequency is 10 kHz and you want to synthesize up to 20 kHz (as might be done with a s & z with zero-order hold on). In this case, you could set both channels to analog to use the analyzer's internal sample frequency of 256 kHz. Now, using 801 lines you can obtain spans of 50kHz, 25kHz, 20 kHz, 10 kHz, and so forth. The inconvenience here is that you must recall your digital set up state from disc if you want to make more digital measurements.

Determining the Synthesis Start and Stop Frequencies

The analyzer uses the frequency-span set up for measurements to determine the synthesis start and stop frequencies. As a reminder, the measurement frequency span is set with the **FREQ** hardkey. Furthermore, the maximum frequency span set with the **FREQ** hardkey is limited by the measurement sample frequency.

For example, if the analyzer is configured for a digital measurement, and the measurement sample frequency is 20 kHz, the s-domain or z-domain synthesis span is limited to 10 kHz.

Performing the Synthesis

After data is entered in a synthesis table, you're ready to perform the synthesis. First, you need to let the analyzer know which synthesis table to use. Press **CREATE TRACE** to choose a synthesis table. If you are in the s domain, you can choose the s-domain synthesis table, or a combination of both the s-domain and the z-domain tables. If you are in the z-domain, you can choose the z-domain synthesis table or a combination of both the s-domain and the z-domain tables.

If you select a synthesis that involves the z-domain, you can include the effect of a digital-to-analog (D/A) converter (commonly called a zero-order hold function). To do this, toggle **0 HOLD ON OFF** to **ON** before you select a synthesis table.

When you press **CREATE TRACE** and choose a synthesis table, the analyzer immediately begins to create a trace based on data in the table. The trace is plotted in the active trace. If both trace A and B are active, the trace is plotted in both the A and B traces. In this way you can obtain two different traces from a single synthesis. For example, to obtain a Bode plot, press **COORD** and set the coordinates for trace A to **MAG (dB)** and the coordinates for trace B to **PHASE**. Then press **A & B** to activate both traces. Then use **CREATE TRACE** to perform the synthesis.

Changing Data Formats in a Synthesis Table

You can change the data format in a synthesis table to any other data format with the **CONVRT TABLE** softkey. This softkey brings up a menu with three softkeys — one softkey for each data format.

Caution



Always use **CONVRT TABLE** to change the data format in a synthesis table. If you try to change the data format using any other method, the data in the synthesis table will be destroyed.

Converting the Domain of a Synthesis Table

The analyzer lets you convert s-domain synthesis tables into z-domain synthesis tables, and vice-versa. The **CONVRT TO Z** softkey lets you convert an s-domain synthesis table into a z-domain synthesis table; the **CONVRT TO S** softkey lets you convert a z-domain synthesis table into an s-domain synthesis table. The **CONVRT TO Z** softkey appears if you are in the z domain; the **CONVRT TO S** softkey appears if you are in the s domain (as determined by the **DOMAIN S Z** softkey; see figure 17-1).

You must set the sample frequency for the conversion process before you press **CONVRT TO S** or **CONVRT TO Z**. When you press either softkey, the table in the target domain (for example, the z-domain synthesis table if you are doing an s-to-z conversion) is erased and replaced with the results of the conversion. Three conversion methods are provided:

- Bilinear
- Impulse Invariance
- Step Invariance

The Bilinear conversion method is affected by frequency warping. The Impulse Invariance and Step Invariance conversion methods are affected by aliasing. The HP 3563A provides another, more powerful, conversion method which does not suffer from frequency warping or aliasing. This alternate method uses the s-domain or z-domain curve fitter to obtain a fit in the opposite domain (for example, z-domain fitting to an s-domain synthesis). The *HP 3563A-1 Product Note* on z-domain curve fitting discusses this alternate method. This alternate method takes longer to do because you must follow the normal setup procedures for curve fitting; whereas the three methods of conversion shown above are activated by a single softkey.

The Synthesis Calculation

A transfer function is represented in a synthesis table as a list of parameters. The analyzer uses these parameters to create a synthesized trace. You put parameters for $H(s)$ in the s-domain synthesis table; you put parameters for $H(z)$ in the z-domain synthesis table. Later, in “The Synthesis Table”, you will learn how to put parameters in a synthesis table.

X-axis Units

The synthesized trace is displayed with the x-axis in Hertz. Consequently, for $H(s)$, the parameters (such as pole positions) must be in Hertz. Since the x-axis is in Hertz, the synthesis equations for $H(s)$ and $H(z)$ are as follows:

$$\text{s domain: } H(s) \mid s = jf$$

$$\text{z domain: } H(z) \mid z = e^{j2\pi fT}$$

where: f is frequency in Hertz
 $\pi = 3.1415\dots$
 T is the sample period.

Notice that the $H(z)$ parameters are unitless — terms are normalized with respect to the unit circle. Also, remember that $H(s)$ transfer functions are frequently expressed in radians. The analyzer expects parameters from the transfer function to be in Hertz. Sometimes you may be starting with an $H(s)$ expressed in radians.

If you modify $H(s)$ to express it in Hertz, you must adjust the gain of $H(s)$ to keep the dc gain constant. To do this for pole-zero or polynomial transfer functions, adjust the gain by a factor of $(2\pi)^{(n - m)}$, where n is the order of the numerator, and m is the order of the denominator. To do this for pole-residue transfer functions, you must adjust the gain for each term in the partial-fraction-expansion. For a simple pole, this means dividing the residue by 2π . For a complex-conjugate pole pair, this means dividing the residue by $(2\pi)^2$.

Entering a Time Delay

Time delay is entered as a separate table parameter with the TIME DELAY softkey. The default is 0 seconds, which has no effect on the synthesis. If you enter a non-zero time delay (t), the $H(s)$ or $H(z)$ synthesis includes multiplication by:

$$e^{-j2\pi ft}$$

where: f is frequency in Hertz
 t is time delay

Entering a Scale Frequency

Additionally, in the s domain, you can enter a scale frequency. The scale frequency is entered with the SCALE FREQ softkey. It scales the frequency axis (the x-axis) by:

$$\frac{f}{\text{scalefreq}}$$

where: f is frequency in Hertz
 scalefreq is the scale frequency

Thus, if you want the frequency axis to be in radians, enter a scale frequency of $1/(2\pi)$. Then enter parameters for $H(s)$ in terms of radians (even though the unit keys still say mHz, kHz, and Hz). The frequency axis is always labeled Hz (Hertz); however, the x-axis cursor should now be interpreted as radians. Units *are not* displayed by scale frequency in the s-domain synthesis table because this is a frequency scaling operation, and hence has units such as Hz/Hz, Hz/kHz, or Hz/mHz — all of which are unitless (except for the k or m base).

The SYNTH Hardkey

You use the **SYNTH** hardkey to set up and perform synthesis. Figure 17-1 shows the softkeys available for this hardkey. The remainder of this chapter tells you how to use these softkeys to set up and perform synthesis.

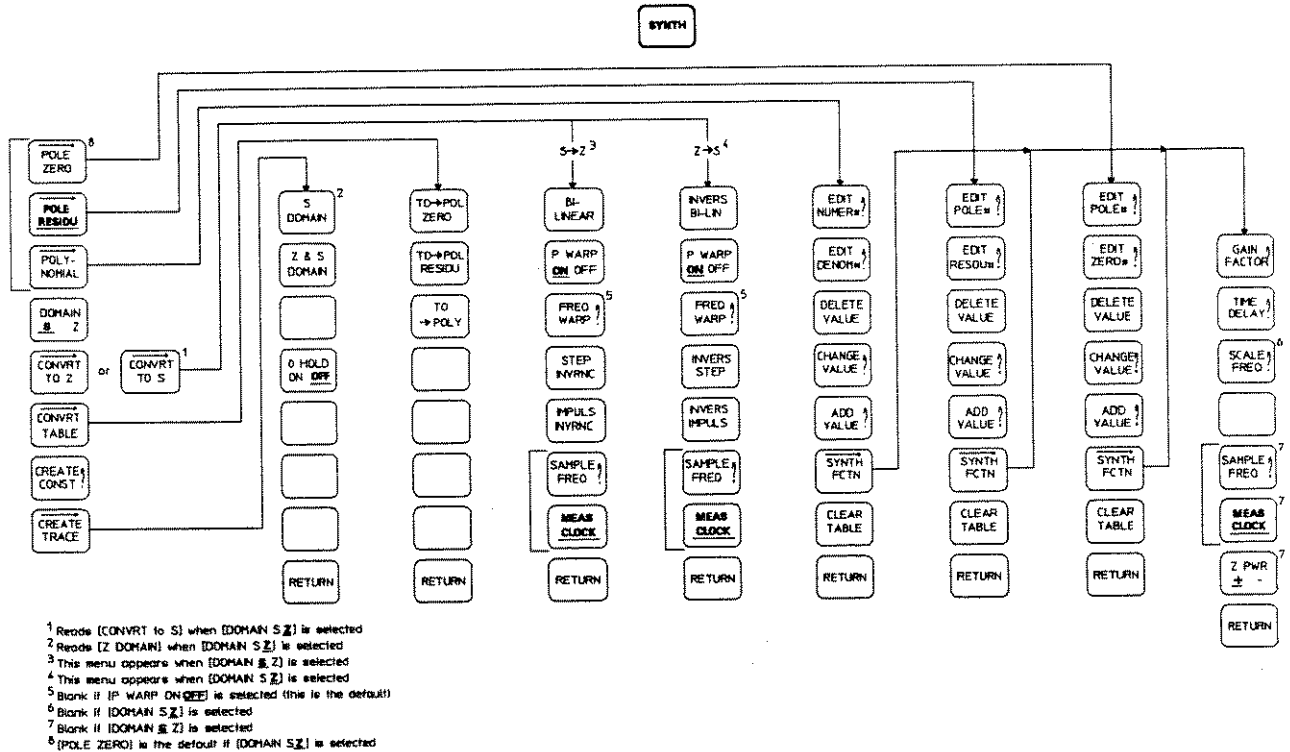

Figure 17-1. SYNTH Menu Diagram

Creating a Synthesis Trace

Use **CREATE TRACE** to create a frequency-response curve based on the current synthesis table. Synthesis is performed over the selected measurement frequency-span. With external sampling, the maximum frequency-span is half the measurement sample frequency ($F_s/2$) if **LINES 1024** is selected (in the **WINDOW** menu). The analyzer displays the message "Synthesis in Progress" as it creates the trace. When finished, the analyzer displays the synthesized trace in the active trace.

The types of models you can synthesize are shown in figure 17-2.

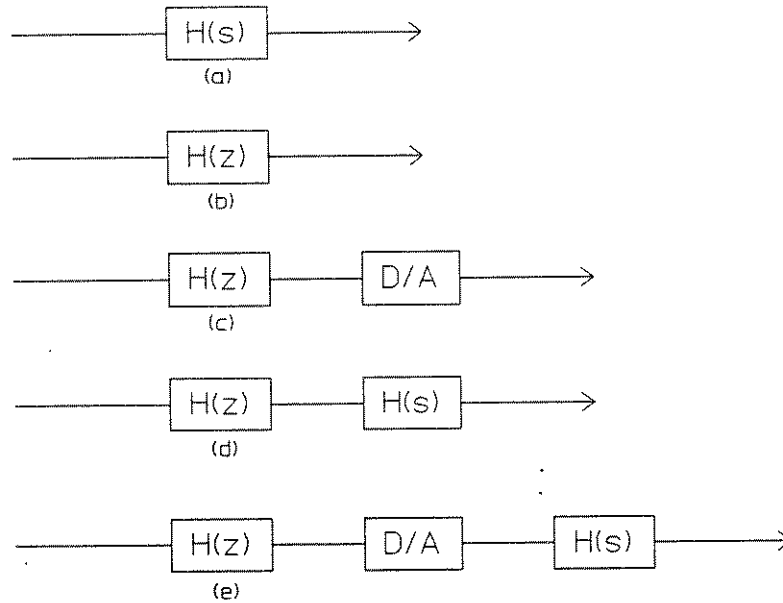

Figure 17-2. Synthesis Modeling Options

The following softkeys appear when you press CREATE TRACE. Use these softkeys to synthesize the models shown in figure 17-2..

- S
DOMAIN** Creates a trace using the s-domain synthesis table. Use this softkey for the $H(s)$ model shown in figure 17-2a. This softkey is available only when the s domain is selected (in other words, when DOMAIN S Z is toggled such that S is highlighted). If the z-domain is selected, this softkey reads Z DOMAIN. The 0 HOLD ON OFF softkey has no affect on s-domain synthesis.
- Z
DOMAIN** Creates a trace using the current z-domain synthesis table. Use this softkey for the $H(z)$ model shown in figure 17-2b. This softkey is available only when the z domain is selected (in other words, when DOMAIN S Z is toggled such that Z is highlighted). If the s-domain is selected, this softkey reads S DOMAIN.
- You may place a zero-order hold after the synthesis table (as modeled in figure 17-2c). With zero-order hold ON, the synthesized trace is interpreted as having a D/A converter after $H(z)$, producing continuous output. With zero-order hold OFF, the synthesized trace represents the frequency response of a sampled system. This is the default condition. See the description of the 0 HOLD ON OFF softkey for a description of zero-order hold.
- Z & S
DOMAIN** Creates a trace using the current z-domain synthesis table followed by the current s-domain synthesis table (as modeled in figure 17-2d). As a reminder, both synthesis tables exist at all times.
- You may place a zero-order hold between the tables (as modeled in figure 17-2e). See the description of the 0 HOLD ON OFF softkey for a description of zero-order hold. Although the zero-order hold doesn't have to be selected, you should toggle it to ON unless you plan on taking into account a different digital-to-analog reconstruction scheme.

Note



For Z & S DOMAIN traces, the time delays of both synthesis tables are effectively added together.

Additionally, the effect of computational delay for a digital filter can be simulated by entering a delay term into either the s-domain or z-domain synthesis table (using the TIME DELAY softkey).

0 HOLD
ON OFF

Places a zero-order hold after a z-domain synthesis table or between the z-domain and the s-domain synthesis tables when Z & S DOMAIN is selected. Zero-order hold produces a $(\sin x)/x$ gain/phase vs frequency plot. A zero-order hold is defined as:

$$[(1 - e^{-Ts}) / s] / T$$

where: s is replaced by $j2\pi f$
 T is the sample period.

The factor of $1/T$ forces the gain to equal 1.0 at 0 Hz, instead of T. Note that in an actual circuit, there is another multiplying gain term. This term corresponds to the maximum voltage (V_{max}) used in the A/D and D/A converters, and the gain associated with any reconstruction filter after the D/A converter (which could be handled in the gain term in either the H(s) or H(z) table).

For example, suppose you want to synthesize the model in figure 17-2e. In this case, press CREATE TRACE and toggle 0 HOLD ON OFF to ON. Then press Z & S DOMAIN. Don't forget to toggle 0 HOLD ON OFF to OFF if you want to exclude the D/A model from future synthesis operations using Z DOMAIN or Z & S DOMAIN.

The Synthesis Table

The synthesis table contains data used by the analyzer for the synthesis operation. It contains the pole and zero (or pole/residue or polynomial) locations plus any gain, time delay or scaling frequency parameters. There are two synthesis tables that exist at all times: one for the s domain, and another for the z domain. Either table may contain data in one of the following formats:

- Pole zero
- Partial fraction (pole residue)
- Polynomial data.

Use the DOMAIN S Z softkey to select a synthesis table. Toggle DOMAIN S Z to S to select the s-domain synthesis table; toggle DOMAIN S Z to Z to select the z-domain synthesis table.

Note



Number sizes in a synthesis table are limited to a maximum of 99.999 E36, and a minimum of 1.47 E- 39.

Also, you may change the data format in a synthesis table at any time. When you change data formats, the contents of the synthesis table are erased- unless you use the CONVRT TABLE softkey. For example, assume the synthesis table is filled with pole-zero data and you want to fill it with pole-residue data. If you press POLE RESIDU, the synthesis table is erased when you press any of the POLE RESIDU editing softkeys. If instead, you press CONVRT TABLE followed by TO → POL RESIDU, the data in the synthesis table is not erased; it is converted from pole-zero to pole-residue. See “Converting Data Formats” for details.

Pole-Zero Data

To enter pole-zero data in a synthesis table, press POLE ZERO. When you press this softkey, the synthesis table appears for the selected domain. For pole-zero data, the synthesis table is split into two columns: the left side for poles and the right side for zeros. Poles (or zeros) can be either real or complex conjugate pairs. Conjugate pairs occupy one line. Real poles or zeros also occupy one line (real poles are called simple poles; real zeros are called simple zeros). A $\pm j$ distinguishes a complex conjugate pair from a simple pole or zero.

Any order of simple or conjugate pairs can be entered in the synthesis table. However, the synthesis table is limited to a maximum of 22 lines. Therefore, you can enter up to a maximum of 44 poles and 44 zeros if every line contains a conjugate pair.

Note



The requirement of conjugate pairs means that only Hermitian symmetric pole-zero data is supported.

Entering Pole-Zero Data: s-Domain

To express your s-domain transfer function in pole-zero format, use the following formula:

$$H(s) = K \frac{(s - Z_1)(s - Z_2)(s - Z_2^*) \dots (s - Z_n)}{(s - P_1)(s - P_2)(s - P_3)(s - P_3^*) \dots (s - P_m)}$$

where: * is the conjugate
K is the system Gain
P is the pole position
Z is the zero position

This formula makes it easy to enter pole-zero data into the s-domain synthesis table. Pole and zero positions are in Hertz. During synthesis, the analyzer replaces s with jf (where f is frequency in Hertz).

Entering Pole-Zero Data: z-Domain

To enter pole-zero data in the z-domain synthesis table, you must be aware of *Zpower* parameters. In the z-domain synthesis table, the status line indicates either +Zpower or -Zpower. Unlike the s domain, z domain $H(z)$ transfer functions are sometimes written in negative exponential powers of z. This is usually done with partial fraction expansion or polynomial ratio expressions. The HP 3563A includes a -Zpower for pole-zero data to provide a complete feature set.

Entering Pole-Zero Data: +Zpower

For +Zpower, express your transfer function in pole-zero format using the following formula:

$$H(z) = K \frac{(z - Z_1)(z - Z_2)(z - Z_2^*) \dots (z - Z_n)}{(z - P_1)(z - P_2)(z - P_3)(z - P_3^*) \dots (z - P_m)}$$

where: * is the conjugate
K is the system Gain
P is the pole position
Z is the zero position

This formula makes it easy to enter transfer function parameters into the z-domain synthesis table for +Zpower. Pole and zero positions are unitless (because the z plane is unitless). During synthesis, the analyzer replaces z with $e^{j2\pi fT}$ (where f is frequency in Hertz, and T is the sample period).

Entering Pole-Zero Data: -Zpower

For -Zpower, express your transfer function in pole-zero format using the following formula:

$$H(z) = K \frac{(1 - Z_1 z^{-1})(1 - Z_2 z^{-1})(1 - Z_2^* z^{-1}) \dots (1 - Z_n z^{-1})}{(1 - P_1 z^{-1})(1 - P_2 z^{-1})(1 - P_3 z^{-1})(1 - P_3^* z^{-1}) \dots (1 - P_m z^{-1})}$$

where: * is the conjugate
K is the system Gain
P is the pole position
Z is the zero position

This formula makes it easy to enter transfer function parameters into the z-domain synthesis table for -Zpower. During synthesis, the analyzer replaces z with $e^{j2\pi fT}$. See "Polynomial Data" and "Pole-Residue Data" for additional -Zpower examples.

s-Domain Exercise: Pole-Zero Data

This exercise shows you how to enter pole-zero data into the s-domain synthesis table. It then shows you how to synthesize the data. The transfer function for this exercise is:

$$H(s) = \frac{1 \times 10^6 (s - 600)}{(s + 250)(s + 500 - j2000)(s + 500 + j2000)}$$

where pole and zero terms are in Hz (thus, scale frequency = 1.0 will be used).

Note



The remainder of this chapter contains s-domain and z-domain exercises for all three data formats. All s-domain exercises use the same transfer function. Likewise, all z-domain exercises use the same transfer function. The s-domain and z-domain exercises in “Polynomial Data” and “Pole-Residue Data” are presented so that you do not have to reenter data in the synthesis table. Instead, the exercises show you how to use the CONVRT TABLE softkey to convert the data from the previous format.

Therefore, you may want to complete the s-domain exercises for all three data formats first. Then read the z-domain exercises (starting with the pole-zero data).

Clearing the Synthesis Table

The following steps show you how to clear the s-domain synthesis table. They also show you how to select the pole-zero data format:

1. If a measurement is running, press **PAUSE/CONT** to stop the measurement.
2. Press **SYNTH** to display the synthesis softkeys. Notice that one of the softkeys for the three data formats is highlighted. Furthermore, the **DOMAIN S Z** key has either **S** or **Z** highlighted.
3. If necessary, toggle **DOMAIN S Z** to the s domain (so that **S** is highlighted).
4. Press the highlighted data-format softkey (**POLE ZERO**, **POLE RESIDU**, or **POLYNOMIAL**). This brings up the table edit softkeys.
5. Press **CLEAR TABLE** twice to clear the existing table.
6. Press **RETURN** to go back to the main synthesis menu.
7. Press **POLE ZERO**. If a data-format softkey other than **POLE ZERO** is highlighted, a message appears indicating that further editing will erase the contents of the synthesis table. Since you want to erase the synthesis table, disregard this message.

Caution



When you press an unhighlighted data-format softkey, the analyzer expects you to enter a new data format in the synthesis table. Thus, the analyzer clears the screen and displays a message indicating that further editing will erase the contents of the synthesis table. If you unintentionally press an unhighlighted data-format softkey, simply press **RETURN** followed by the highlighted data-format softkey to redisplay the synthesis table. Use **CONVRT TABLE** to convert the data to another data format (see “Converting Data Formats” for details).

Entering Pole-Zero Data

The following information shows you how to enter pole-zero data in the synthesis table. The information is presented in two columns. Press the keys in the left column to enter the data. Read the brief description in the right column to learn the results of pressing a key. Refer to the softkey descriptions for the "Pole-Zero Editing Softkeys" later in this chapter if you need additional details.

EDIT POLE#	Activates editing of the pole column.
ADD VALUE	Lets you add values to the synthesis table. If you make a typing error, press the BACK SPACE hardkey to retype digits. Furthermore, if you enter an incorrect value, press EDIT POLE# again and use the up arrow key (or knob) to move the highlighted line to the line in error. Then press DELETE VALUE.
- 250 Hz	Adds a real pole at - 250 Hz, corresponding to $s + 250$. Enter the number - 250 with the numeric entry pad. Then press the Hz softkey to terminate numeric entry and enter the number in the synthesis table. The lower left side of the display shows what you are typing.
- 500,2000 Hz	Adds the conjugate pole pair, corresponding to $(s + 500 - j2000) \times (s + 500 + j2000)$. Again, use the numeric entry pad to enter both numbers separated by a comma. Press the Hz softkey to terminate numeric entry.
EDIT ZERO#	Activates editing of the zero column.
ADD VALUE	
600 Hz	
SYNTH FCTN	Adds a real zero at 600 Hz, corresponding to $(s - 600)$. Displays another menu that lets you add functions such as gain factor or time delay.
GAIN FACTOR	
1E6	Adds a gain factor of 1E6. Enter the number 1 with the numeric entry pad, press the EXP softkey, then enter the number 6. Press the ENTER softkey to complete entry.
RETURN	
RETURN	

At this point, your synthesis table should look like figure 17-3.

Synthesis
Pole-Zero Data

S Synthesis					
	POLES		3	ZEROS	1
1	-250.0			600.0	
2	-500.0 ± j		2.0k		

Time delay= 0.0 S
Scale Frequency= 1.0

Gain= 1.0M

Figure 17-3. Example s-Domain Synthesis Table:
Pole-Zero Data

Performing the Synthesis

You are now ready to synthesize the pole-zero transfer function, $H(s)$. This exercise synthesizes $H(s)$ from 0 Hz to 20 kHz. The easiest way to do this is to use the analyzer's internal sample frequency (which runs at 256 kHz). The analyzer uses its internal sample frequency when both input channels are configured for analog data. At this time, press **INPUT CONFIG** and make sure that both channel 1 and channel 2 are configured for analog data (in other words, CHAN 1 AN DIG and CHAN 2 AN DIG are toggled to AN). Then complete the following steps:

FREQ

FREQ SPAN

(Optional. Although START FREQ is highlighted, notice that the lower left corner of the display prompts you to enter the frequency span.)

20 kHz

Sets the span to 20 kHz. Enter the number 20 on the numeric entry pad, then press the kHz softkey.

START FREQ

Check to see that 0 Hz is shown in the lower left corner of the display.

WINDOW

LINES 801

Synthesize with 801 lines (you must use 801 lines for all examples in this chapter.

A

Activates trace A.

COORD

MAG (dB)

Sets trace A to display the magnitude in dB.

SYNTH

Displays the synthesis menu.

CREATE TRACE

Displays the create trace menu.

S DOMAIN

Creates the s-domain synthesis of $H(s)$. Plots the results in trace A.

SCALE

Y AUTO SCALE

At this point, you should have a plot in trace A as shown in figure 17-4. To go back to the synthesis table, press **SYNTH** followed by the highlighted data-format softkey. Press **A** to redisplay the trace.

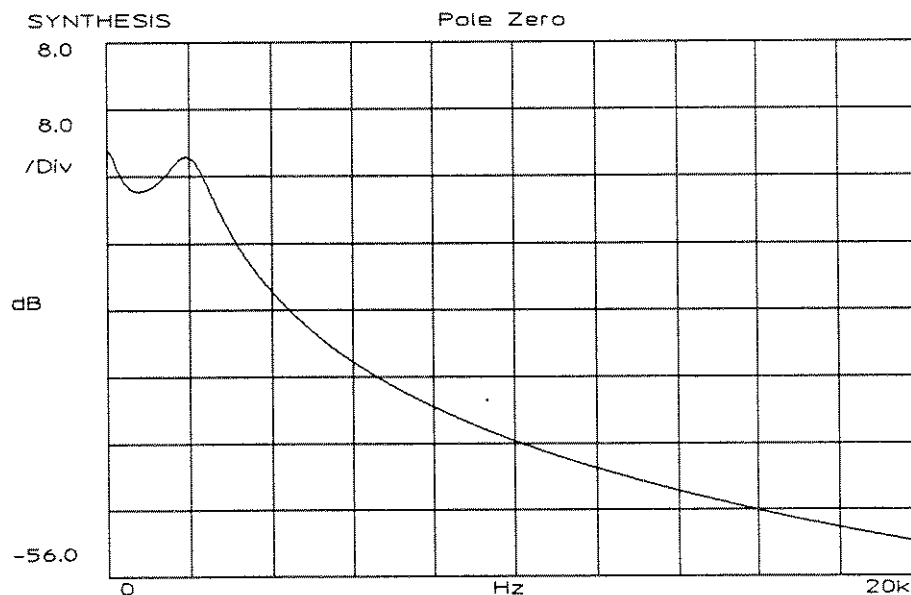

Figure 17-4. Example s-Domain Synthesis Plot

z-Domain Exercise: Pole-Zero Data

This exercise shows you how to enter pole-zero data into the z-domain synthesis table. It then shows you how to synthesize the data. The transfer function for this exercise is:

$$H(z) = \frac{(z + .3)}{(z - .1 - j.2)(z - .1 + j.2)}$$

Note



The following z-domain exercise assumes you have completed the previous s-domain exercise. Information presented previously in the s-domain exercise is not duplicated here. See the s-domain exercise if you do not understand a concept presented here.

Clearing the Synthesis Table

You use similar procedures to clear both the s-domain and z-domain synthesis tables. First, press **SYNTH** and toggle **DOMAIN S Z** to the z domain (so that **Z** is highlighted). Then press the highlighted data-format softkey and press **CLEAR TABLE** twice.

Entering Pole-Zero Data

Before you enter data in the z-domain synthesis table, you must first select the **Zpower**. Since the equation for this exercise is written in terms of positive powers of **z**, select **+Zpower**. To select **+Zpower**, press **SYNTH FCTN** to display the synthesis function menu (this menu is shown in figure 17-1). Toggle **Z PWR + -** so that **+** is highlighted. The status line on the display should now indicate **+Zpower**.

At this time, add pole-zero data to the synthesis table as shown in figure 17-5. Notice that units are not used for z-domain data because **H(z)** terms are normalized with respect to the unit circle. You will need to enter the pole as **.1, .2** and the zero as **-.3** (the **m** indicates millia).

Z Synthesis			
POLES	z	ZEROS	1
1	100.0m ± j	200.0m	-300.0m
Time delay- 0.0 S		Gain- 1.0	
Sample Frequency- 20.0kHz		+Zpower	

**Figure 17-5. Example z-Domain Synthesis Table:
+Zpower Pole-Zero Data**

Entering Sample Frequency

Observe that the table status line displays Scale Frequency for s-domain synthesis tables (see figure 17-3) and Sample Frequency for z-domain synthesis tables (see figure 17-5). You may set the Scale Frequency for s-domain synthesis tables (default is 1). You must set the Sample Frequency for z-domain synthesis tables because the $H(z)$ synthesis calculation requires a sample period, T , to determine the period of the digital frequency response. The sample period is obtained from the reciprocal of the Sample Frequency in the synthesis table.

To set the z-domain sample frequency, press **SYNTH FCTN** to display the synthesis function menu. Then press **SAMPLE FREQ** and enter 20 kHz. Press **RETURN** twice to return to the main synthesis menu.

Performing the Synthesis

The following information shows you how to synthesize $H(z)$ from 0 Hz to 20 kHz, without the effects of a zero-order hold. The procedure for setting the frequency span is identical for both domains (s and z). However, if you have been making digital measurements, you must return the analyzer to the internal sample rate, 256 kHz. To do this, press **INPUT CONFIG** and make sure that both channel 1 and channel 2 are configured for analog data (in other words, CHAN 1 AN DIG and CHAN 2 AN DIG are toggled to AN).

Note



If you use external sampling for digital or mixed measurements, the maximum span is limited by the measurement sample frequency (see “Determining the Number of Data Points Generated by the Synthesis” at the beginning of this chapter).

This example synthesizes beyond the Nyquist rate (half the sample frequency). If you are making digital measurements with a sample frequency of 20 kHz, the maximum span allowed is 10 kHz (minus one frequency bin). Thus, you must return the analyzer to the internal sample rate (256 kHz) to get spans beyond 10 kHz.

If you are continuing from the previous s -domain exercise (you are using the internal sample rate, 256 kHz), you don't need to set the frequency parameters or the trace coordinates — these should be configured properly. If you have modified the frequency parameters, press **FREQ** and set the start frequency to 0 Hz and the stop frequency to 20 kHz. Press **WINDOW** and make sure the **LINES 801** softkey is selected. Then press **A** to activate trace A. Then press **COORD** and set the trace coordinates to **MAG (dB)**.

You are now ready to synthesize the pole-zero transfer function, $H(z)$. Press **CREATE TRACE** followed by **Z DOMAIN** (make sure **0 HOLD ON OFF** is **OFF**). You should see a trace like figure 17-6 (you may need to do **Y AUTO SCALE** to obtain proper scaling). Notice how the frequency response from 10 kHz to 20 kHz is a mirror image of the frequency response from 0 Hz to 10 kHz. This entire shape repeats every 20 kHz if you extend the frequency span and perform a new synthesis. This frequency-response replication is a fundamental nature of the digital frequency-response. Therefore, if you are designing a digital filter to replace an analog filter, you should select the sample frequency to be high enough to cover the frequency range of interest in the analog filter.

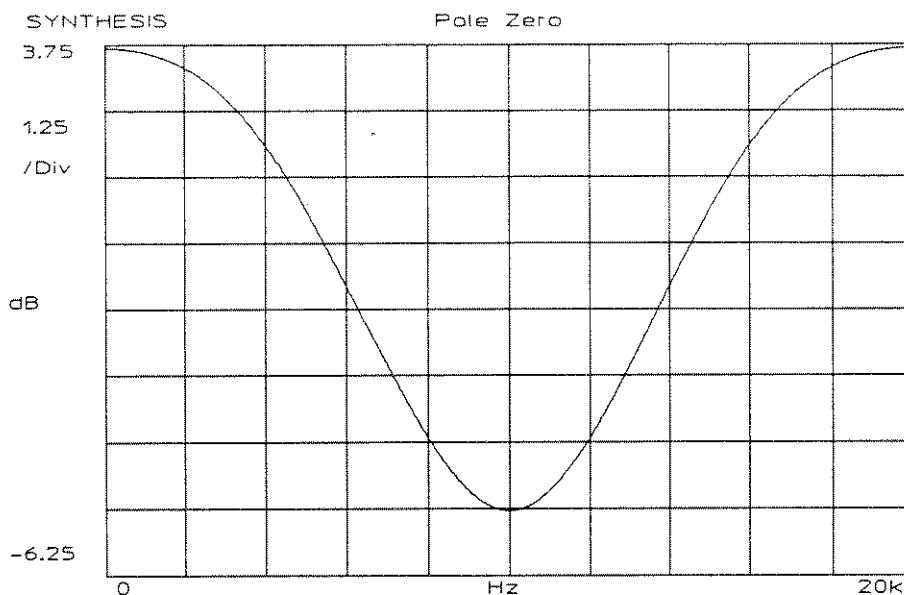

**Figure 17-6. Example z-Domain Synthesis Plot:
+ Zpower Pole-Zero Data**

Performing the Synthesis With a Zero-Order-Hold

To perform the synthesis with the effects of a zero-order hold, toggle 0 HOLD ON OFF to ON before you select Z DOMAIN. In this case, you will see D/A rolloff on the response out to the sample frequency. Try this again with a frequency span of 50 kHz and you will see the $(\sin x)/x$ rolloff imposed on the replicated frequency response. The $(\sin x)/x$ null points occur at multiples of the sample frequency.

Performing the Synthesis With a -Zpower

To perform the synthesis with a -Zpower, return to the top of the synthesis menu (to do this, press **SYNTH**). Press the highlighted data-format softkey. Then press **SYNTH FCTN** and toggle **Z PWR + - to -**. Your synthesis table should now look identical to figure 17-7.

Z Synthesis				
	POLES		ZEROS	
	1	2	1	2
1	100.0m±j	200.0m	-300.0m	
2			0.0	
Time delay= 0.0 S		Gain= 1.0		
Sample Frequency= 20.0kHz		-Zpower		

**Figure 17-7. Example z-Domain Synthesis Table:
-Zpower Pole-Zero Data**

Notice that -Zpower introduces a 0.0 term in the zero column of the synthesis table. This results from transforming the +Zpower equation into a -Zpower equation, as follows:

$$\begin{aligned}
 \text{+Zpower equation: } H(z) &= \frac{(z + .3)}{(z - .1 - j.2)(z - .1 + j.2)} \\
 &= \frac{z(1 + .3z^{-1})}{z^2(1 - (.1 + j.2)z^{-1})(1 - (.1 - j.2)z^{-1})} \\
 \text{-Zpower equation:} &= \frac{z^{-1}(1 + .3z^{-1})}{(1 - (.1 + j.2)z^{-1})(1 - (.1 - j.2)z^{-1})}
 \end{aligned}$$

When z is factored out of the pole and zero terms, an extra factor of z^{-1} appears in the synthesis table. In fact, multiple factors of z^{-1} may appear, depending on the difference in order of the denominator and numerator. For example, if the +Zpower equation contains 1 pole and 2 zeros, one (2 zeros - 1 pole) extra z^{-1} term appears in the synthesis table's pole column when you convert to -Zpower. Conversely, if the +Zpower equation contains 2 poles and 1 zero, one extra z^{-1} term appears in the synthesis table's zero column when you convert to -Zpower. This means that many extra poles in +Zpower create many 0.0 terms in the zero column when converted to -Zpower. Likewise, many extra zeros in +Zpower create many 0.0 terms in the pole column when converted to -Zpower. This creates a size limitation for -Zpower orders.

Note



In $-Z$ power, the synthesis table is still limited to a maximum of 22 lines. When converting a table that is in $+Z$ power and has, for example, 12 lines of complex conjugate pole-pairs, and no zeros, changing to $-Z$ power requires 24 lines of 0.0 entries. Since there is not enough table space, the analyzer displays the error message "Table Overflow in Cnvt" if you try to change to $-Z$ power.

Additionally, in $-Z$ power, table entry checks for potential overflows. Hence, if you have a table with 11 lines of complex conjugate pole-pairs and are entering data while in $-Z$ power, you will get an "Out of Range" error message if you try to type in the 12th line.

Note



Since the $+Z$ power and $-Z$ power conversions are simply rearrangements of $H(z)$, synthesis using either form gives the same frequency response.

Polynomial Data

To enter polynomial data in a synthesis table, press POLYNOMIAL. When you press this softkey, the synthesis table appears for the selected domain. For polynomial data, the synthesis table is split into two columns: the left side for the numerator polynomial and the right side for the denominator polynomial. Table entries are interpreted as coefficients of the s or z polynomial. Entries should be real (you are actually allowed to enter complex coefficients, and can synthesize such a table, but you can't perform table conversions on them — a table with complex coefficients is not Hermitian symmetric).

The first line in the synthesis table corresponds to the numerator and denominator coefficients for s^0 , the second line corresponds to s^1 , and the nth line corresponds to s^{n-1} . Column lengths can be different, up to a maximum of 22 lines.

Entering Polynomial Data: s-Domain

To express your s-domain transfer function in polynomial format, use the following formula:

$$H(s) = K \frac{(a_1s^0 + a_2s^1 + a_3s^2 + \dots + a_ns^{n-1})}{(b_1s^0 + b_2s^1 + b_3s^2 + \dots + b_ms^{m-1})}$$

where: K is the system Gain

This formula makes it easy to enter polynomial data into the s-domain synthesis table. Polynomial coefficients are in Hertz. During synthesis, the analyzer replaces s with jf (where f is frequency in Hertz).

Entering Polynomial Data: z-Domain

To enter polynomial data into the z-domain synthesis table, you must be aware of Zpower parameters. In the z-domain synthesis table, the status line indicates either +Zpower or -Zpower. Unlike the s domain, z domain H(z) transfer functions are sometimes written in negative exponential powers of z. This is quite common with polynomial data: the coefficients for a digital filter are found by putting the H(z) equation in terms of negative z powers, where the numerator coefficients correspond to the input delay terms, and the denominator coefficients correspond to the output delay terms.

Entering Polynomial Data: + Zpower

For +Zpower, express your transfer function in polynomial format using the following formula:

$$H(z) = K \frac{(a_1z^0 + a_2z^1 + a_3z^2 + \dots a_nz^{n-1})}{(b_1z^0 + b_2z^1 + b_3z^2 + \dots b_mz^{m-1})}$$

where: K is the system Gain

This formula makes it easy to enter transfer function parameters into the z-domain synthesis table for +Zpower. Polynomial coefficients are unitless (because the z plane is unitless). During synthesis, the analyzer replaces z with $e^{j2\pi fT}$ (where f is frequency in Hertz, and T is the sample period).

Entering Polynomial Data: - Zpower

For - Zpower, express your transfer function in polynomial format using the following formula:

$$H(z) = K \frac{(a_1z^0 + a_2z^{-1} + a_3z^{-2} + \dots a_nz^{-(n-1)})}{(b_1z^0 + b_2z^{-1} + b_3z^{-2} + \dots b_mz^{-(m-1)})}$$

where: K is the system Gain

This formula makes it easy to enter transfer function parameters into the z-domain synthesis table for - Zpower. Again, the polynomial coefficients are unitless. During synthesis, the analyzer replaces z with $e^{j2\pi fT}$.

s-Domain Exercise: Polynomial Data

This exercise shows you how to enter polynomial data into the s-domain synthesis table. It then shows you how to synthesize the data.

Note



This exercise is a continuation of the s-domain, pole-zero exercise. Information presented previously for that exercise is not duplicated here. Therefore, see “s-Domain Exercise: Pole-Zero Data” if you do not understand a concept presented here.

The transfer-function equation used earlier for the pole-zero s-domain exercise can be expanded to form the polynomial ratio as follows:

$$\text{Pole-zero equation: } H(s) = \frac{1 \times 10^6 (s - 600)}{(s + 250)(s + 500 - j2000)(s + 500 + j2000)}$$

$$\text{Polynomial equation: } = \frac{1.0 \times 10^6 s - 600 \times 10^6}{s^3 + 1.25 \times 10^3 s^2 + 4.5 \times 10^6 s + 1.062 \times 10^9}$$

Figure 17-8 shows the s-domain synthesis table for this polynomial equation.

S Synthesis		
	NUMERATOR 1	DENOMINATOR 3
1	-600.0M	1.062E+09
2	1.0M	4.5M
3		1.25K
4		1.0
	s^0 s^1	s^0 s^1 s^2 s^3
Time delay= 0.0 S		Gain= 1.0
Scale Frequency= 1.0		

Figure 17-8. Example s-Domain Synthesis Table: Polynomial Data

Converting to Polynomial Data

If you have not erased the synthesis table you created in “s-Domain Exercise: Pole-Zero Data”, you can obtain the table shown in figure 17-8 by simply converting the data in the table to polynomial format. If you did erase the synthesis table, skip this section and go to “Entering the Polynomial Data.”

To convert data in the synthesis table to polynomial format, press the following keys:

SYNTH

DOMAIN S Z	Make sure this key is toggled to the s domain (S is highlighted).
CONVRT TABLE	Brings up the data format conversion menu.
TO→ POLY	Converts the data in the synthesis table to polynomial format.

The data in the synthesis table is now in polynomial format. Furthermore, the POLYNOMIAL softkey is highlighted. If you wanted to return the data to the pole-zero format, you could press CONVRT TABLE followed by TO→ POL ZERO.

Entering the Polynomial Data

If you erased the synthesis table created in “s-Domain Exercise: Pole-Zero Data”, you must reenter the data to perform this exercise. To do this, press the following keys:

SYNTH

POLYNOMIAL	Begins entry of data in polynomial format.
EDIT NUMER#	Begins editing the numerator column.
ADD VALUE	
- 600 EXP 6	Use the ENTER softkey after typing 6.
1 EXP 6	
EDIT DENOM#	Begins editing the denominator column.
ADD VALUE	
1.062 EXP 9	
4.5 EXP 6	
1.25 EXP 3	
1	
RETURN	
RETURN	

Performing the Synthesis

You are now ready to synthesize the polynomial transfer function, $H(s)$. This exercise synthesizes $H(s)$ from 0 Hz to 20 kHz. If you are continuing from the pole-zero s-domain exercise, you don't need to set the frequency parameters or the trace coordinates — these should be configured properly. Otherwise, press **FREQ** and set the start frequency to 0 Hz and the stop frequency to 20 kHz. Press **WINDOW** and make sure the **LINES 801** softkey is selected. Then press **A** to activate trace A. Next, press **COORD** and set the trace coordinates to **MAG (dB)**. Furthermore, make sure that both input channels are analog so that the exercise uses the analyzer's internal sample frequency (see "s-Domain Exercise: Pole-Zero Data" for details).

To perform the synthesis, press **SYNTH CREATE TRACE** followed by **S DOMAIN**. Notice that the Gain from a table conversion to polynomial format is multiplied into the numerator terms. Your response should be the same as that obtained for the s-domain pole-zero exercise (see figure 17-4).

z-Domain Exercise: Polynomial Data

This exercise shows you how to enter polynomial data into the z-domain synthesis table. It then shows you how to synthesize the data.

Note

This exercise is a continuation of the z-domain, pole-zero exercise. Information presented previously for that exercise is not duplicated here. Therefore, see "z-Domain Exercise: Pole-Zero Data" if you do not understand a concept presented here.

The transfer-function equation used earlier for the pole-zero z-domain exercise can be expanded to form the polynomial ratio as follows:

$$\text{Pole-zero equation: } H(z) = \frac{(z + .3)}{(z - .1 - j.2)(z - .1 + j.2)}$$

$$\text{Polynomial equation: } = \frac{.3 + z}{.05 - .2z + z^2}$$

Figure 17-9 shows the z-domain synthesis table for this polynomial equation.

Z Synthesis					
	NUMERATOR	1	DENOMINATOR	2	
1		300.0m		50.0m	
2		1.0		-200.0m	
3				1.0	
Time delay-		0.0 S		Gain-	1.0
Sample Frequency-		20.0kHz		+Zpower	

**Figure 17-9. Example z-Domain Synthesis Table:
+Zpower Polynomial Data**

Converting to the Polynomial Format

If you have not erased the z-domain synthesis table you created in “z-Domain Exercise: Pole-Zero Data”, you can obtain the table shown in figure 17-9 by simply converting the data in the table to polynomial format. If you did erase the z-domain synthesis table, skip this section and go to “Entering the Polynomial Data.”

To convert data in the z-domain synthesis table to polynomial format, press the following keys:

SYNTH

- DOMAIN S Z Toggle this to select the z domain.
- POLE ZERO Pole zero is the highlighted data-format softkey.
- SYNTH FCTN Press this key and check the resultant menu to make sure that Z PWR + - is toggled to +.
- RETURN
- RETURN
- CONVRT TABLE
- TO→POLY Converts data in the synthesis table to polynomial format.

The data in the synthesis table is now in polynomial format (as shown in figure 17-9). Furthermore, the POLYNOMIAL softkey is highlighted. If you wanted to return the data to the pole-zero format, you could press CONVRT TABLE followed by TO→POL ZERO.

Entering Polynomial Data

If you erased the z-domain synthesis table created in “z-Domain Exercise: Pole-Zero Data”, you must reenter the data to perform this exercise. To do this, press the following keys:

SYNTH

POLYNOMIAL	Disregard the warning message: we want to erase the other data format anyway.
SYNTH FCTN	
Z PWR + -	Toggle this softkey to highlight +.
RETURN	
EDIT NUMER#	Begins editing the numerator column.
ADD VALUE	
.3	Use the ENTER softkey after typing “.3”.
1	
EDIT DENOM#	Begins editing the denominator column.
ADD VALUE	
.05	
-.2	
1	
RETURN	
RETURN	

Performing the Synthesis

You are now ready to synthesize the polynomial transfer function, $H(z)$. This exercise synthesizes $H(z)$ from 0 Hz to 20 kHz. If you are continuing from the pole-zero z-domain exercise, you don't need to set the frequency parameters or the trace coordinates — these should be configured properly. Otherwise, press **FREQ** and set the start frequency to 0 Hz and the stop frequency to 20 kHz. Press **WINDOW** and make sure the **LINES 801** softkey is selected. Then press **A** to activate trace A. Next, press **COORD** and set the trace coordinates to **MAG (dB)**. Furthermore, make sure the sample frequency is still 20 kHz (press **SYNTH FCTN** followed by **SAMPLE FREQ**). See “z-Domain Exercise: Pole-Zero Data” for details.

To perform the synthesis, press **SYNTH CREATE TRACE** followed by **Z DOMAIN** (make sure **0 HOLD ON OFF** is **OFF**). Your response should be the same as that obtained for the z-domain pole-zero exercise (see figure 17-6).

Performing the Synthesis With a - Zpower

To perform the synthesis with a - Zpower, return to the top of the synthesis menu (to do this, press **SYNTH**). Press the highlighted data-format softkey. Then press **SYNTH FCTN** and toggle **Z PWR + -** to **-**. Your synthesis table should now look identical to figure 17-10.

Z Synthesis				
	NUMERATOR	Z	DENOMINATOR	Z
1	0.0	← Z ⁰	1.0	← Z ⁰
2	1.0	← Z ⁻¹	-200.0m	← Z ⁻¹
3	300.0m	← Z ⁻²	50.0m	← Z ⁻²
Time delay- 0.0 S		Gain- 1.0		
Sample Frequency- 20.0kHz		-Zpower		

Figure 17-10. Example z-Domain Synthesis Table:
-Zpower Polynomial Data

Notice that the numerator z⁰ place is filled with a 0.0, and the order of the coefficients is reversed. This results from transforming the +Zpower equation into a -Zpower equation, as follows:

$$\begin{aligned}
 \text{+Zpower equation: } H(z) &= \frac{.3 + z}{.05 - .2z + z^2} \\
 &= \frac{z^2(.3z^{-2} + z^{-1} + 0z^0)}{z^2(.05z^{-2} - .2z^{-1} + 1)} \\
 \text{-Zpower equation: } &= \frac{0 + z^{-1} + .3z^{-2}}{1 - .2z^{-1} + .05z^{-2}}
 \end{aligned}$$

The power of z factored out of the numerator and denominator is always the highest order of z present in the transfer function. Thus, after entering a +Zpower polynomial equation, converting to -Zpower results in columns of equal length if the equation did not have any contiguous 0.0 entries at the top of the table. If you do, these are taken into account during factoring and result in columns of different lengths.

Note



Since the +Zpower and -Zpower conversions are simply rearrangements of H(z), synthesis using either form gives the same frequency response.

Partial Fraction (Pole-Residue) Data

To enter partial-fraction (pole-residue) data, press POLE RESIDU. When you press this softkey, the synthesis table appears for the selected domain. For pole-residue data, the synthesis table is split into two columns: the left column for poles; the right column for residues (a residue is another name for the numerator constant) for each pole term in the partial-fraction expansion. Poles can be simple (real), or entered as a complex conjugate pair. A pole and its residue are always on the same line in the synthesis table (unlike pole-zero tables, where order doesn't matter). A $\pm j$ distinguishes a complex conjugate pole-pair from a simple pole. Since a complex conjugate pole-pair corresponds to two terms in a partial-fraction expansion, the residue is also interpreted as being a complex-conjugate pair.

Entering Pole-Residue Data: s-Domain

To express your s-domain transfer function in pole-residue format, use the following formula:

$$H(s) = K [c_1s^0 + c_2s^1 + \dots$$
$$\frac{A_1}{(s - P_1)} + \frac{A_2}{(s - P_2)} + \frac{A_2^*}{(s - P_2^*)} + \frac{A_3}{(s - P_3)} + \frac{A_3^*}{(s - P_3^*)} +$$
$$\frac{A_4}{(s - P_3)^2} + \frac{A_4^*}{(s - P_3^*)^2} + \dots]$$

where: * is the conjugate
K is the system Gain
P is the pole position
A is the residue (a constant, possibly complex)
c terms caused by numerator order \geq denominator order

This formula makes it easy to enter pole-residue data into the s-domain synthesis table. Pole positions are in Hertz. During synthesis, the analyzer replaces s with jf (where f is frequency in Hertz). If the same pole (real or conjugate) is entered more than once, the pole term is surrounded by parenthesis and its order is indicated by s^k , where k is the multiplicity. There are no c terms if the numerator order is less than the denominator order.

Note For pole-residue, the values in the synthesis table must be identical in order to be identified as a multiple order pole. Thus, if you convert the synthesis table to pole-residue format, then add a pole that appears to be the same, it probably won't be identified as the same pole due to rounding errors in the conversion.

Entering Pole-Residue Data: z-Domain

To enter pole-residue data into the z-domain synthesis table, you must be aware of *Zpower* parameters. In the z-domain synthesis table, the status line indicates either +Zpower or -Zpower. Unlike the s-domain, z-domain $H(z)$ transfer functions in partial-fraction expansion form are often written in the form $A/(1 - Pz^{-1})$. This form gives an exponential time-domain decay of the form $A \times P^n$, where n is the index in a discrete-time sequence. Notice that $A/(z - P)$ does not have a nice closed-form inverse z transform giving an exponential time-domain decay, whereas this same form in the s-domain does have an exponential decay.

If you write $A/(1 - Pz^{-1})$ in terms of positive powers of z , you get: $(A \times z)/(z - P)$, which is not compatible with the analyzer's s-domain interpretation. To avoid confusion, the analyzer uses +Zpower partial-fraction expansion equations in the same form as that used in the s-domain, except s is replaced with z .

Entering Pole-Residue Data: +Zpower

For +Zpower, express your transfer function in pole-residue format using the following formula:

$$H(z) = K [c_1 z^0 + c_2 z^1 + \dots + \frac{A_1}{(z - P_1)} + \frac{A_2}{(z - P_2)} + \frac{A_2^*}{(z - P_2^*)} + \frac{A_3}{(z - P_3)} + \frac{A_3^*}{(z - P_3^*)} + \frac{A_4}{(z - P_3)^2} + \frac{A_4^*}{(z - P_3^*)^2} + \dots]$$

where: * is the conjugate
 K is the system Gain
 P is the pole position
 A is the residue (a constant, possibly complex)
 c terms caused by numerator order \geq denominator order

This formula makes it easy to enter transfer function parameters into the z-domain synthesis table for +Zpower. Pole positions are unitless (because the z plane is unitless). During synthesis, the analyzer replaces z with $e^{j2\pi fT}$ (where f is frequency in Hertz, and T is the sample period).

Entering Pole-Residue Data: – Zpower

For – Zpower, express your transfer function in pole-residue format using the following formula:

$$H(z) = K [c_1 z^0 + c_2 z^1 + \dots$$

$$\frac{A_1}{(1 - P_1 z^{-1})} + \frac{A_2}{(1 - P_2 z^{-1})} + \frac{A_2^*}{(1 - P_2^* z^{-1})} + \frac{A_3}{(1 - P_3 z^{-1})} + \frac{A_3^*}{(1 - P_3^* z^{-1})} +$$

$$\frac{A_4}{(1 - P_3 z^{-1})^2} + \frac{A_4^*}{(1 - P_3^* z^{-1})^2} + \dots]$$

where: * is the conjugate
 K is the system Gain
 P is the pole position
 A is the residue (a constant)
 c terms caused by numerator order \geq denominator order

This formula makes it easy to enter transfer function parameters into the z-domain synthesis table for – Zpower. Again, the polynomial coefficients are unitless. During synthesis, the analyzer replaces z with $e^{j2\pi fT}$. Notice that with – Zpower, the C terms (called Laurent terms) are still in terms of positive powers of z .

Note

For the z domain:

Converting between +Zpower and – Zpower in pole-residue form requires a new partial-fraction-expansion calculation — it is not a trivial process of factoring out powers of z (as is the case for pole-zero and polynomial data). Consequently, the analyzer displays the message 'Do Manually for Pole-Res' if you are in pole-residue form and you try to toggle the Zpower.

To change the Zpower for pole-residue form, first convert the data to another format (such as polynomial). Then toggle the Zpower with Z PWR + – and convert the data back into pole-residue form.

If you clear the pole-residue table, you can change the Zpower sign before entering new table parameters.

Reconstructing Simple Poles

To reconstruct the pole-residue equation from the synthesis table, you must associate poles with their residues. Poles and their residues are always on the same line in the synthesis table. Simple poles and residues are easy to reconstruct. The equation for a simple residue over a simple pole is:

$$\frac{(\text{Residue})}{s - (\text{Simple Pole})}$$

where: (*residue*) is the real residue in the table and its sign
 (*simple pole*) is the real pole and its sign in the table across from its residue

Note Placing a complex conjugate residue over a simple pole creates a non-Hermitian symmetric transfer function. These should not be synthesized. Also, table conversions are not allowed.

Reconstructing Complex Conjugate Pole-Pairs

For complex conjugate pole-pairs, you must associate poles with their residues to reconstruct the pole-residue equation from the synthesis table. Poles and their residues are always on the same line in the synthesis table.

Complex poles and their residues use a formula similar to that shown in the previous section. However, the sign of the imaginary part of a complex residue is now significant. Unlike complex pole terms, the imaginary part of a complex residue can have a sign. An example table entry is: $1.0 \pm j - 2.0$. Here, the $\pm j$ indicates a complex residue, and the minus sign in front of the imaginary part (2.0) indicates the sign of the imaginary part of the residue in the First Conjugate Term. The equation for a complex residue over a complex pole is:

$$\frac{(\text{Real part in table}) + j (\text{Imaginary part in table})}{s - (\text{Real part in table}) - j(\text{Imaginary part in table})} + \frac{(\text{Real part in table}) - j (\text{Imaginary part in table})}{s - (\text{Real part in table}) + j(\text{Imaginary part in table})}$$

← First Conjugate Term

where: *(real part in table)* is the real number and its sign
(imaginary part in table) is the imaginary number (no sign for poles)

Associating the sign of the imaginary part of a complex residue with the First Conjugate Term establishes the sign convention for the imaginary part of the complex conjugate pole-pair. Notice that the second conjugate term is formed by conjugating the residue and pole in the First Conjugate Term.

In the case of a simple (real) residue over a complex conjugate pole-pair, the formula used is:

$$\frac{(\text{Residue})}{s - (\text{Real part in table}) - j(\text{Imaginary part in table})} + \frac{(\text{Residue})}{s - (\text{Real part in table}) + j(\text{Imaginary part in table})}$$

where: *(residue)* is the real residue in the table
(real part in table) is the real number and its sign
(imaginary part in table) is the imaginary number (no sign for poles)

In this case, the residue has no imaginary part. Thus, there is no sign association between the residue and the complex conjugate pole-pair.

The following tables show how to reconstruct the First Conjugate Term for all possible sign entries in the synthesis table. Since both the real and imaginary parts of the residue can be minus, there are four possible table entries for residues (see table 17-1). Since only the real part of the pole can be minus, there are only two possible table entries for poles (see table 17-2). Table 17-1 shows the numerator constant and table 17-2 shows its denominator for example table entries.

Table 17-1 Reconstructing the First Conjugate Term: Residue

Table Entry	Numerator Constant (residue)
.5 ± j 1.0	.5 + j 1.0
-.5 ± j 1.0	-.5 + j 1.0
-.5 ± j -1.0	-.5 - j 1.0
.5 ± j -1.0	.5 - j 1.0

Table 17-2. Reconstructing the First Conjugate Term: Pole

Table Entry	Denominator (pole)
.6 ± j 2.0	s - .6 - j2.0
-.6 ± j 2.0	s + .6 - j2.0

Example

As an example, look at the synthesis table in figure 17-11. Notice that the table contains the following:

- One simple pole and an associated simple residue
- One complex conjugate pole and an associated complex conjugate residue

Using the preceding formulas, the equation for this table is as follows (generate the *second conjugate term* by conjugating the *first conjugate term*):

$$\begin{aligned}
 H(s) &= \frac{\overbrace{(-209.231)}^{\text{real number in table}}}{s - \overbrace{(-250)}^{\text{real number in table}}} + \frac{\overbrace{(104.615)}^{\text{real number in table}} + \overbrace{j(-263.077)}^{\text{imaginary number in table}}}{s - \overbrace{(-500)}^{\text{real number in table}} - \overbrace{j(2000)}^{\text{imaginary number in table}}} + \frac{\overbrace{(104.615)}^{\text{real number in table}} - \overbrace{j(-263.077)}^{\text{imaginary number in table}}}{s - \overbrace{(-500)}^{\text{real number in table}} + \overbrace{j(2000)}^{\text{imaginary number in table}}} \\
 &= \frac{-209.231}{s + 250} + \frac{104.615 - j263.077}{s + 500 - j2000} + \frac{104.615 + j263.077}{s + 500 + j2000} \\
 &\quad \text{First Conjugate Term}
 \end{aligned}$$

s-Domain Exercise: Pole-Residue Data

This exercise shows you how to enter pole-residue data into the s-domain synthesis table. It then shows you how to synthesize the data.

Note

This exercise is a continuation of the s-domain, pole-zero and polynomial exercises. Information presented previously for these exercises is not duplicated here. Therefore, if you do not understand a concept presented here, first see "s-Domain Exercise: Pole-Zero Data", then see "s-Domain Exercise: Polynomial Data."

A partial-fraction-expansion can be performed on the transfer-function equation used earlier for the pole-zero s-domain exercise to give a pole-residue equation as follows:

$$\text{Pole-zero equation: } H(s) = \frac{1 \times 10^6 (s - 600)}{(s + 250)(s + 500 - j2000)(s + 500 + j2000)}$$

$$\text{Pole-residue equation: } = \frac{-209.231}{s + 250} + \frac{104.615 - j263.077}{s + 500 - j2000} + \frac{104.615 + j263.077}{s + 500 + j2000}$$

First Conjugate Term

Figure 17-11 shows the s-domain synthesis table for the pole-residue equation.

S Synthesis		
	POLES	RESIDUES
1	-250.0	-209.231
2	-500.0 ± j	104.615 ± j-263.077
	3	2.0k
Time delay- 0.0 S		Gain- 1.0
Scale Frequency- 1.0		

**Figure 17-11. Example s-Domain Synthesis Table:
 Pole-Residue Data**

Converting to Pole-Residue Data

If you have not erased the synthesis table you created in the previous s-domain exercises (see “s-Domain Exercise: Pole-Zero Data” or “s-Domain Exercise: Polynomial Data”), you can obtain the table shown in figure 17-11 by simply converting the data to pole-residue. If you did erase the s-domain synthesis table, skip this section and go to “Entering the Pole-Residue Data.”

To convert data in the synthesis table to pole-residue format, press the following keys:

SYNTH

CONVRT TABLE Brings up the table format conversion menu.

TO→POL RESIDU Converts the data in the synthesis table to the pole-residue format.

The data in the synthesis table is now in pole-residue format. Furthermore, the **POLE RESIDU** softkey is highlighted. If you wanted to return the data to the pole-zero format, you could press **CONVRT TABLE** followed by **TO→POL ZERO**. Or, press **CONVRT TABLE** followed by **TO→POLY** to return the data to polynomial format.

Entering Pole-Residue Data

If you erased the s-domain synthesis table created in "s-Domain Exercise: Pole-Zero Data" or in "s-Domain Exercise: Polynomial Data", you must reenter the data to perform this exercise. To reenter data, press the following keys:

SYNTH

POLE RESIDU	Begins entry of a new table in pole-residue form.
EDIT POLE#	Begins editing of the pole column.
ADD VALUE	
- 250 Hz	
- 500,2000 Hz	
EDIT RESDU#	Begins editing of the residue column.
ADD VALUE	
- 209.231	Use ENTER to complete the numeric entry.
104.615, - 263.077	
RETURN	

Performing the Synthesis

You are now ready to synthesize the pole-residue transfer function, $H(s)$. This exercise synthesizes $H(s)$ from 0 Hz to 20 kHz. If you are continuing from the pole-zero or polynomial s-domain exercise, you don't need to set the frequency parameters or the trace coordinates — these should be configured properly. Otherwise, press **FREQ** and set the start frequency to 0 Hz and the stop frequency to 20 kHz. Press **WINDOW** and make sure the **LINES 801** softkey is selected. Then press **A** to activate trace A. Next, press **COORD** and set the trace coordinates to **MAG (dB)**. Furthermore, make sure that both input channels are analog so that the exercise uses the analyzer's internal sample frequency (see "s-Domain Exercise: Pole-Zero Data" for details).

To perform the synthesis, press **SYNTH CREATE TRACE** followed by **S DOMAIN**. Notice that the Gain from a table conversion to pole-residue format is multiplied into the numerator terms. Your response should be the same as that obtained for the s-domain pole-zero exercise (see figure 17-4).

z-Domain Exercise: Pole-Residue Data

This exercise shows you how to enter pole-residue data into the z-domain synthesis table. It then shows you how to synthesize the data.

Note This exercise is a continuation of the z-domain, pole-zero and polynomial exercises. Information presented previously for these exercises is not duplicated here. Therefore, if you do not understand a concept presented here, first see "z-Domain Exercise: Pole-Zero Data", then see "z-Domain Exercise: Polynomial Data."

The transfer-function equation used earlier for the pole-zero z-domain exercise can be expanded to give a pole-residue equation as follows:

$$\text{Pole-zero equation: } H(z) = \frac{(z + .3)}{(z - .1 - j.2)(z - .1 + j.2)}$$

$$\text{Pole-residue equation: } = \frac{.5 - j1.0}{z - .1 - j.2} + \frac{.5 + j1.0}{z - .1 + j.2}$$

First Conjugate Term

Figure 17-12 shows the z-domain synthesis table for the pole-residue equation.

Synthesis
 Partial Fraction (Pole-Residue) Data

Z Synthesis			
	POLES	Z	RESIDUES
1	100.0m±j	200.0m	500.0m±j -1.0
Time delay- 0.0 S		Gain- 1.0	
Sample Frequency- 20.0kHz		+Zpower	

**Figure 17-12. Example z-Domain Synthesis Table:
 +Zpower Pole-Residue Data**

Converting to Pole-Residue Format

If you have not erased the z-domain synthesis table you created in “z-Domain Exercise: Pole-Zero Data” or “z-Domain Exercise: Polynomial Data”, you can obtain the table shown in figure 17-12 by simply converting the data to pole-residue format. If you did erase the z-domain synthesis table, skip this section and go to “Entering the Pole-Residue Data.”

To convert data in the z-domain synthesis table to pole-residue format, press the following keys:

SYNTH

- DOMAIN S Z Toggle this to select the z domain.
- POLYNOMIAL Polynomial is the highlighted data-format softkey (if polynomial was the last exercise you did).
- SYNTH FCTN exercise you did).
- RETURN Press this key and check to make sure that Z PWR + - is toggled to +.
- RETURN
- CONVRT TABLE
- TO POL→RESIDU Converts data in the synthesis table to pole-residue format.

The data in the synthesis table is now in pole-residue format (as shown in figure 17-12). Furthermore, the POLE RESIDU softkey is highlighted. Notice that the Gain from a table conversion to pole-residue format is multiplied into the numerator terms. If you wanted to return the data to the pole-zero format, you could press CONVRT TABLE followed by TO→POL ZERO. Or, if you wanted to return the data to the polynomial format, you could press CONVRT TABLE followed by TO→POLY.

Entering Pole-Residue Data

If you erased the z-domain synthesis table created in the previous z-domain exercises (see “z-Domain Exercise: Pole-Zero Data” or “z-Domain Exercise: Polynomial Data”), you must reenter the data to perform this exercise. To do this, press the following keys:

SYNTH

POLE RESIDU	Disregard the warning message: we want to erase the other data format anyway.
SYNTH FCTN	
Z PWR + -	Toggle this softkey to highlight +.
RETURN	
EDIT POLE#	Begins editing of the pole column.
ADD VALUE	
.1,2	Use ENTER to complete the numeric entry.
EDIT RESDU#	Begins editing of the residue column.
ADD VALUE	
.5,- 1	Use ENTER to complete the numeric entry.
RETURN	

You should now see the synthesis table shown in figure 17-12.

Performing the Synthesis

You are now ready to synthesize the pole-residue transfer function, $H(z)$. This exercise synthesizes $H(z)$ from 0 Hz to 20 kHz. If you are continuing from the pole-zero or polynomial z-domain exercise, you don't need to set the frequency parameters or the trace coordinates — these should be configured properly. Otherwise, press **FREQ** and set the start frequency to 0 Hz and the stop frequency to 20 kHz. Then press **A** to activate trace A. Next, press **COORD** and set the trace coordinates to **MAG (dB)**. Furthermore, make sure the sample frequency is still 20 kHz (press **SYNTH FCTN** followed by **SAMPLE FREQ**). See “z-Domain Exercise: Pole-Zero Data” for details.

To perform the synthesis, press **SYNTH CREATE TRACE** followed by **Z DOMAIN** (make sure **0 HOLD ON OFF** is **OFF**). Your response should be the same as that obtained for the z-domain pole-zero exercise (see figure 17-6).

Performing the Synthesis With a - Zpower

In pole-residue format, to perform the synthesis with a - Zpower, you must first convert the data in the synthesis table to another format (see “Entering - Zpower Pole-Residue Data” earlier in this section).

For this exercise, convert the data in the synthesis table to pole-zero format. Then change to - Zpower and convert the table back to pole-residue form. Your table should appear like figure 17-13.

Synthesis
Partial Fraction (Pole-Residue) Data

Z Synthesis				
POLES		Z	RESIDUES	
1	100.0m ± j	200.0m	-3.0 ± j	-4.0
2	Z=0		6.0	

Time delay- 0.0 S Gain- 1.0
Sample Frequency- 20.0kHz -Zpower

Figure 17-13. Example z-Domain Synthesis Table:
-Zpower Pole-Residue Data

The pole-residue equation that corresponds to the table in figure 17-13 is as follows:

$$H(z) = 6 + \frac{-3 - j4}{1 - (.1 + j.2)z^{-1}} + \frac{-3 + j4}{1 - (.1 - j.2)z^{-1}}$$

First Conjugate Term →

Notice that the table values now look quite different from those of figure 17-12. Getting a new partial fraction expansion from the equation for this example involves putting the equation into pole-zero form (the theory is easier to understand if you look at it from pole-zero form, rather than polynomial form) and changing to -Zpower form. Now make the substitution $x = z^{-1}$ and rewrite pole and zero terms in the form $(x + \text{pole position})$, which involves reciprocating pole and zero positions and adjusting the gain. Proceed with a partial-fraction-expansion in terms of x , and you get the equation shown above.

Observe that with -Zpower, the rule for the denominator of the first conjugate term is (the first conjugate term is described earlier in "Reconstructing Complex Conjugate Pole-Pairs"):

$$1 - (\text{real part in table} + j \text{imaginary part in table})z^{-1}$$

As another example, the following equation corresponds to figure 17-14:

$$H(z) = \frac{-j2.5}{1 - (-.1 + j.2)z^{-1}} + \frac{j2.5}{1 - (-.1 - j.2)z^{-1}} + \frac{-.3}{1 + .4z^{-1}} + \frac{1.5}{(1 + .4z^{-1})^2}$$

Z Synthesis			
POLES		4	RESIDUES
1	-100.0m ± j	200.0m	0.0 ± j -2.5
2	400.0m		-300.0m
3	(400.0m)~2		1.5
Time delay= 0.0 S		Gain= 1.0	
Sample Frequency= 20.0kHz		-Zpower	

**Figure 17-14. Example z-Domain Synthesis Table:
 -Zpower Pole-Residue Data**

The indication of 4 poles in figure 17-14 reflects the denominator order (though at first it might seem that there are 5 poles, collecting a common denominator yields an order of 4).

Converting Domains

The HP 3563A allows you to convert a synthesis table from the s domain to the z domain, and vice-versa. To do this, press **SYNTH** followed by **CONVRT TO S** or **CONVRT TO Z** (see figure 17-1). Only one of these softkeys is displayed, depending upon the selected domain. **CONVRT TO Z** is displayed if the s-domain is selected; **CONVRT TO S** is displayed if the z-domain is selected. The synthesis table can be in any data format before performing a domain conversion.

Note

The analyzer displays **SYNTH TABLE CONVERSION** as it converts the synthesis table from one domain to another. In the case of the step invariance transform, this message appears and disappears several times before the conversion completes.

Furthermore, converting between the s and z domains changes the contents of the target synthesis table. Moving between the s and z domains (by selecting the domain with the **DOMAIN S Z** softkey) does *not* affect the contents of the synthesis table.

Additional examples are available in chapter 4 of the *HP 3563A Getting Started Guide*.

Converting From the s-Domain to the z-Domain

The HP 3563A lets you convert s-domain synthesis tables into z-domain synthesis tables, and vice-versa. The **CONVRT TO Z** softkey lets you convert an s-domain synthesis table into a z-domain synthesis table; the **CONVRT TO S** softkey lets you convert a z-domain synthesis table into an s-domain synthesis table. The **CONVRT TO Z** softkey appears if you are in the z domain; the **CONVRT TO S** softkey appears if you are in the s domain (as determined by the **DOMAIN S Z** softkey; see figure 17-1).

There is no perfect way to go between the s and z domain. A digital filter frequency-response repeats every multiple of the sample frequency to produce a periodic frequency response. An analog filter frequency-response is non-periodic. The HP 3563A provides the most popular transforms used by digital designers to transform analog designs into digital approximations. The three methods available are:

- Impulse Invariance Transformation
- Step Invariance Transformation
- Bilinear Transformation

If you start with a stable $H(s)$, these three methods provide a stable digital filter design by mapping left-half s-plane poles inside the unit circle of the z-domain.

The Impulse and Step Invariance Transforms

The Impulse and Step Invariance Transforms are very similar in nature: they preserve the impulse or step response of the analog filter. In other words, the digital filter's discrete impulse or step response matches the sampled version of the analog filter response. However, the frequency response of the digital filter does not exactly match the analog filter. This is because the Impulse Invariance Transformation has the effect of adding a shifted version of the analog frequency response to the original frequency response. The shifting occurs at multiples of the sample frequency (the theory requires inclusion of the negative frequency axis as well; the negative response is simply a reflection across the y axis of the positive response). Thus, unless the analog frequency response is bandlimited to half the sample frequency, tails of shifted versions are added on top of the original frequency response, causing an 'aliased' response (the theory behind the step response is basically the same).

The Bilinear Transformation

Alternately, aliasing can be avoided with the Bilinear Transform. However, the Bilinear Transform introduces frequency warping (The HELP text, on page 2 of the P WARP ON OFF softkey, shows how this warping occurs). With frequency warping, the entire $j\omega$ axis of the s plane is mapped into the frequency range of zero to $F_s/2$. The higher analog frequencies are compressed more as you approach $F_s/2$. This mapping process follows a tangential curve; therefore, it is roughly linear for frequencies well below $F_s/2$ (assuming pre-warping is off).

This mapping process can be modified to match the frequency response between the s and z domain at a specific frequency. To do this, use the analyzer's pre-warping feature (see the description of the P WARP ON OFF softkey in "Key Reference").

Domain Transform Using the Curve Fitter

The Bilinear conversion method is affected by frequency warping. The Impulse Invariance and Step Invariance conversion methods are affected by aliasing. The HP 3563A provides another, more powerful, conversion method which does not suffer from frequency warping or aliasing. This alternate method uses the s -domain or z -domain curve fitter to obtain a fit in the opposite domain (for example, z -domain fitting to an s -domain synthesis). The *HP 3563A-1 Product Note* on z -domain curve fitting discusses this alternate method. Chapter 11 also discusses this method (see "z-Domain Curve Fitting to Analog Responses" in that chapter). This alternate method takes longer to do because you must follow the normal setup procedures for curve fitting; whereas the three methods of conversion shown above are activated by a single softkey.

Note The time delay term does not affect the transformation. It is, however, copied into the target table.

Furthermore, the sample frequency, $1/T$, used for these transformations is taken from the current z -domain table.

Impulse Invariance Exercise

This exercise shows you how to convert a synthesis table from the s-domain to the z-domain using the Impulse Invariance Transformation. To do this exercise, you need the s-domain synthesis table used in the data format exercises. The synthesis table can be in any of the three forms: figure 17-3, figure 17-8, or figure 17-11. To compare the analog design with the transformed digital design, this exercise synthesizes the magnitude response of both and uses **FRONT BACK** to compare them.

Begin by pressing the following keys:

SYNTH

DOMAIN S Z	Toggle this key to the s domain.
CONVRT TO Z	Displays the convert menu.
SAMPLE FREQ	Make sure 20 kHz is displayed for the sample frequency. If needed, type in 20 kHz. If the a trace had been displayed, this would have caused the synthesis table to be displayed: this is okay; no conversion has been done yet.
IMPULS INVRNC	Performs the Impulse Invariance Transformation. You are placed in the z domain. The result is presented in pole-residue form because these terms correspond to the components of the impulse response, and are the basis of the method.

You should now see the synthesis table shown in figure 17-15.

A	Activates trace A.
DOMAIN S Z	Toggle back to the s domain.
CREATE TRACE	If you have been following the exercises, your span should be 0 to 20 kHz. See the pole-zero exercise if you need instructions to do this.
S DOMAIN	Creates an S domain trace in A.
B	Activates trace B.
DOMAIN S Z	Toggle this key to the z domain.
CREATE TRACE	Make sure 0 HOLD ON OFF is toggled to OFF.
Z DOMAIN	Creates a z-domain trace in B.
A&B	
SCALE	
Y FIXD SCALE	
10, - 60 (dB)	Match both y scales.
FRONT BACK	

You should now observe the plot shown in figure 17-16.

Z Synthesis		
	POLES	RESIDUES
1	924.465m	-1.31464k
2	691.415m ± j 502.342m	657.318 ± j -1.65296k
Time delay = 0.0 S		Gain = 50.0μ
Sample Frequency = 20.0kHz		-Zpower

**Figure 17-15. Example z-Domain Synthesis Table:
Impulse Invariance**

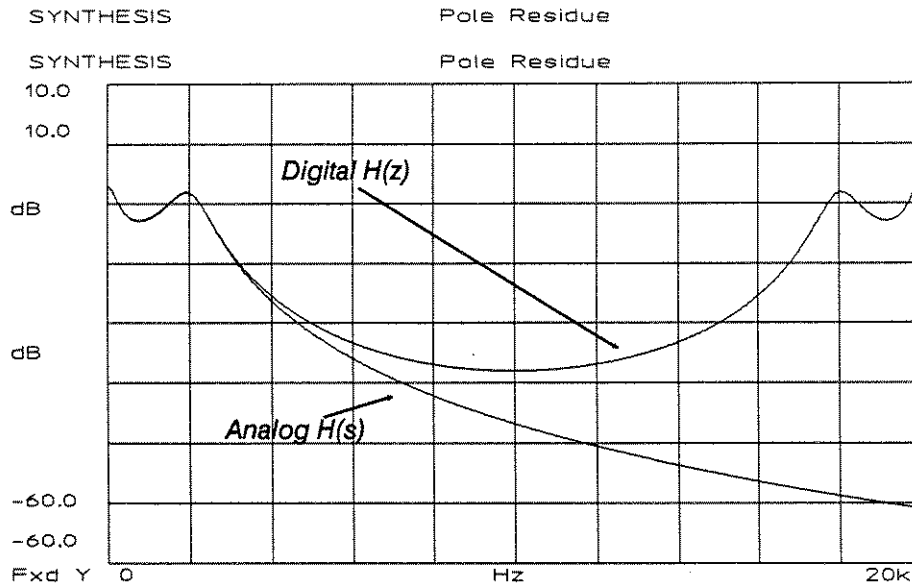

**Figure 17-16. Analog Synthesis vs. Digital Synthesis:
Impulse Invariance**

Bilinear Transform Exercise

This exercise shows you how to convert a synthesis table from the s-domain to the z-domain using the Bilinear Transform. This exercise is a continuation of the previous "Impulse Invariance Exercise."

Begin by pressing the following keys:

- B** Activates trace B.
- SYNTH**
- DOMAIN S Z** Toggle this key to the s domain.
- CONVRT TO Z** Displays the convert menu.
- P WARP ON OFF** Toggle to ON.
- FREQ WARP**
- 4 kHz** This exercise designs the z-domain filter to match the s domain response at 4 kHz. The synthesis table is displayed. This is okay; no conversion has happened yet.
- BILINEAR** Performs the bilinear transformation.
- DOMAIN S Z** Toggle this key to the z domain.
- CREATE TRACE**
- Z DOMAIN**

Now press **FRONT BACK** if needed (have you kept the y scales fixed the same for A and B?).

You should see the response shown in figure 17-17.

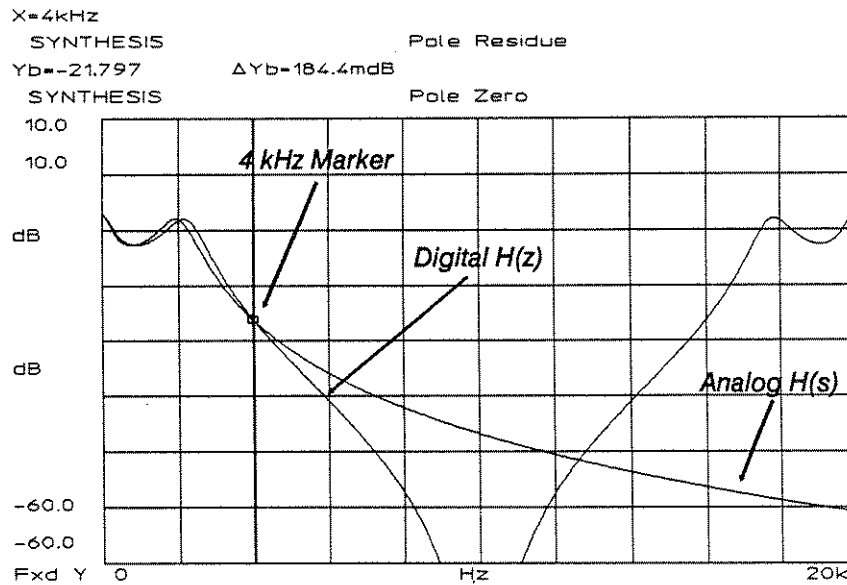

**Figure 17-17. Analog Synthesis vs. Digital Synthesis:
 Bilinear Transformation**

Note that the vertical marker in figure 17-17 is $x = 4$ kHz, the frequency at which both the s and z domain frequency response magnitudes match. Phase matches as well at the pre-warp frequency (4 kHz).

For a description of the softkeys that appear when you press CONVRT TO S, see “Key Reference” later in this chapter.

Converting from the z-Domain to the s-Domain

You use the CONVRT TO S softkey to convert a synthesis table from the s domain to the z domain. This softkey is available only when the z domain is selected (in other words, when DOMAIN S Z is toggled such that Z is underlined and highlighted). If the s domain is selected, this softkey reads CONVRT TO Z. There are many z to s conversion methods. They vary in the type of approximation used to relate z to s. The HP 3563A provides the following three methods:

- Inverse Bilinear Transformation
- Inverse Step Invariance Transformation
- Inverse Impulse Invariance Transformation

For a description of these conversion methods, see the description of the CONVRT TO Z softkey in the following section, “Key Reference.”

Converting Table Formats

As mentioned, the data in a synthesis table may be in pole-zero, pole-residue, or polynomial format. The CONVRT TABLE softkey allows you to convert from one data format to another. When you press CONVRT TABLE, the following softkeys appear:

TO POL ZERO	Converts pole-residue or polynomial data into pole-zero format.
TO POL RESIDU	Converts pole-zero or polynomial data into pole-residue format.
TO POLY	Converts pole-zero or pole-residue data into polynomial format.

Note

Avoid converting tables unnecessarily. Table conversions are not exact because of finite precision in the math operations. It may not always be possible to convert from one representation to another and back, without resulting in slight variations. Also, keep in mind the range of the analyzer's number system (roughly $\pm 10^{37}$).

The message "Not Hermitian" is displayed if coefficients from Pole Residue or Polynomial synthesis-tables are in a table when table format conversion is attempted. The analyzer's curve fitter will not work with a non-Hermitian frequency-response trace (because it is not possible for our pole-zero format to have non-Hermitian table entries).

Transferring Synthesis Tables to Curve-Fit Tables

A Pole-zero synthesis table can be transferred to a curve-fit table. To do this, you must use the **CURVE FIT** hardkey; press **CURVE FIT**, **FIT FCTN**, **SYNTH**→**FIT** (see chapter 16, "Curve Fit", for instructions). To transfer a pole-residue or polynomial synthesis-table to a curve-fit table, first convert the data in the synthesis table to pole-zero format. When you do this, all pole-zero terms in the table become *fixed*. There are conditions for curve-fitting when a table has all pole-zero terms fixed. See chapter 16 for an explanation of *fixed* and additional details.

Key Reference

This section contains detailed information for all softkeys available under the **SYNTH** hardkey. When you press **SYNTH**, the following softkeys appear:

POLE ZERO	Selects pole/zero synthesis and displays the synthesis table and its editing menu; see “Pole-Zero Data” for details. Or, see “The Pole-Zero Editing Softkeys” later in this section for a description of the softkeys that appear when this key is pressed.
POLE RESIDU	Selects pole/residue synthesis and displays the synthesis table and its editing menu; see “Partial Fraction (Pole-Residue) Data” for details. Or, see “The Pole-Residue Editing Softkeys” later in this section for a description of the softkeys that appear when this key is pressed.
POLY- NOMIAL	Selects polynomial synthesis and displays the synthesis table and its editing menu; see “Polynomial Data” for details. Or, see “The Polynomial Editing Softkeys” later in this section for a description of the softkeys that appear when this key is pressed.
DOMAIN S Z	Selects the synthesis table’s domain. The selected domain is underlined and highlighted (the default is the s domain). See “The Synthesis Table” for further details.
CONVRT TO Z	Displays the menu which allows you to convert from the s- domain to the z-domain. This softkey is available only when the s domain is selected (in other words, when DOMAIN S Z is toggled such that S is underlined and highlighted). If the z domain is selected, this softkey reads CONVRT TO S. See “Converting Domains” for details. Or, see “The Convert to z Menu” for a description of the softkeys that appear when this key is pressed.
CONVRT TO S	Displays the menu which allows you to convert from the z- domain to the s-domain. This softkey is available only when the z domain is selected (in other words, when DOMAIN S Z is toggled such that Z is underlined and highlighted). If the s domain is selected, this softkey reads CONVRT TO Z. See “Converting Domains” for details. Or, see “The Convert to s Menu” for a description of the softkeys that appear when this key is pressed.
CONVRT TABLE	Displays the convert tables menu; see “Converting Table Formats” for complete details.

**CREATE
CONST** Creates real or complex constants for use in waveform math. Real values are entered as a single number; complex values are entered as real, imaginary separated by a comma (,). As an example, $6 \pm j3$ is entered as 6,3.

**CREATE
TRACE** Creates a frequency-response curve based on the current synthesis table. The message "Synthesis in Progress" is displayed while the trace is being created, and the trace is displayed in the active trace when the synthesis is complete. See "Creating a Synthesis Trace" for complete details.

Pole-Zero Editing Softkeys

Pressing POLE ZERO displays the editing softkeys for pole-zero data (see figure 17-1) and also displays the synthesis table. Use the editing softkeys to add entries to or change entries in the synthesis table, as follows:

**EDIT
POLE#** Selects the line number of the pole you want to edit. EDIT POLE# does not change the value of the pole, it only selects the pole to be edited. Editing is done with DELETE VALUE, CHANGE VALUE and ADD VALUE.

If you are editing an empty synthesis table, press EDIT POLE# followed by ADD VALUE. Then enter the value of the new pole using the Entry group keypad. To edit an existing synthesis table, press EDIT POLE#, enter the line number of the pole you wish to edit using the Entry group keypad, then press ENTER. (If the appropriate pole is already highlighted you can begin editing immediately- you don't need to press EDIT POLE#).

Poles in the left-half plane are entered with negative real values. The sign of the imaginary value is arbitrary because a pole with a non-zero imaginary part represents a complex conjugate pole pair.

EDIT
ZERO#

Selects the line number of the zero you want to edit. EDIT ZERO# does not change the value of the zero, it only selects the zero to be edited. Editing is done with DELETE VALUE, CHANGE VALUE and ADD VALUE.

If you are editing an empty synthesis table, press the EDIT ZERO# followed by ADD VALUE. Then enter the value of the new zero using the Entry group keypad. To edit an existing synthesis table, press EDIT ZERO#, enter the line number of the zero you wish to edit using the Entry group keypad, then press ENTER. (If the appropriate zero is already highlighted you can begin editing immediately- you don't need to press EDIT ZERO#).

Zeros in the left-half plane are entered as negative values.

DELETE
VALUE

Deletes the highlighted line in the synthesis table. When in pole residue form, be sure to delete both the pole and its corresponding residue.

CHANGE
VALUE

Changes the highlighted line in the synthesis table. When this is active, the highlighted line changes as you enter new values. To change a real-only value, enter the value then press one of the units softkeys. To change a complex value, enter the real value by means of the Entry group keypad, enter a comma (,) enter the imaginary value, then press one of the units softkeys.

In pole residue form, the sign of the imaginary value is significant. It indicates which complex residue is associated with each complex pole.

ADD
VALUE

Adds a new line after the highlighted line in the synthesis table. Enter the new value in mHz, Hz or kHz. Real values are entered as single numbers; complex values are separated by a comma (real,imaginary). For example, $6 \pm j3$ is entered as 6,3 Hz. To insert a new line before the first line in the current table, move the pointer to line #0 (above line #1) and then enter the new value.

You do not need to repeatedly press ADD VALUE. Once you press ADD VALUE, you can enter a sequence of values .

In pole residue form, the sign of the imaginary value is significant. It indicates which complex residue is associated with each complex pole.

SYNTH FCTN	Displays the synthesis functions menu, which is used to enter system gains, time delays and scaling frequencies; see “The Synthesis Functions Menu.”
CLEAR TABLE	Press twice to clear the table. The message “Push Again to Clear” is displayed after the first press to allow you to confirm that the table is to be cleared. Once cleared, tables cannot be recovered. Tables can be saved to disc (see chapter 11 for details).

Polynomial Editing Softkeys

Pressing POLYNOMIAL displays the editing softkeys for polynomial data (see figure 17-1) and also displays the synthesis table. Use the editing softkeys to add entries to or change entries in the synthesis table. The polynomial editing softkeys are identical to the pole-zero editing softkeys with two exceptions- the pole-zero editing softkeys that read EDIT POLE# and EDIT ZERO# change to EDIT NUMER# and EDIT DENOM# for polynomial data. However, the function of the softkeys remains the same. You use EDIT NUMER# to select the line in the synthesis table that contains the polynomial numerator you want to edit; you use EDIT DENOM# to select the line in the synthesis table that contains the polynomial denominator you want to edit.. See “Pole-Zero Editing Softkeys” for a complete description of all editing softkeys.

Pole-Residue Editing Softkeys

Pressing POLE RESIDU displays the editing softkeys for pole-residue data (see figure 17-1) and also displays the synthesis table. Use the editing softkeys to add entries to or change entries in the synthesis table. The pole-residue editing softkeys are identical to the pole-zero editing softkeys with one exception — the pole-zero editing softkey that reads EDIT ZERO# changes to EDIT RESIDU# for pole-residue data. However, the function of the softkey remains the same. You use EDIT RESIDU# to select the line in the synthesis table that contains the residue you want to edit. See “Pole-Zero Editing Softkeys” for a complete description of all editing softkeys.

The Synthesis Functions Menu

The synthesis functions menu (see figure 17-1) allows you to add system gains, time delays and sampling and scaling frequencies to the synthesis table. It also allows you to track the measurement sample frequency (press MEAS CLOCK) and change the sign of z in z -domain synthesis tables. The values entered are used by the instrument when it creates the trace. Note that the values must be entered before the trace is synthesized.

Pressing SYNTH FCTN displays the following menu:

GAIN
FACTOR

Used to enter the constant (K), if needed, to set the desired gain of a synthesized frequency-response function (see the example following this menu). The default value for new tables is 1.0. Gain is entered as a unitless number and cannot be 0. To enter the gain value in exponential notation, enter the base using the Entry group keypad. Then press EXP followed by ENTER.

The gain value is displayed in the lower right corner of the table. See “GAIN FACTOR: Analog Circuits” and “GAIN FACTOR: Digital Circuits” for additional information.

TIME
DELAY

Adds time delays to synthesized functions, either digital or analog (s , z , and s & z). The delay is entered in microseconds, milliseconds or seconds; the default is 0.0 seconds. Time delay can be used to simulate computational delay in a sampled system. Negative delays correspond to an advance. Enter the time delay using the Entry group and the units softkeys. The delay you enter is displayed in the lower left corner of the synthesis table.

When synthesizing with both s and z tables, the time delay for each table is added together. The computational delay entered for a digital measurement with the COMPUT DELAY softkey (DATA CLOCK menu under INPUT CONFIG) is not added to the time delay and does not affect the synthesis. The delay will show the “phase racking” normally associated with long computational or transport delay associated with normal feedback control systems.

SCALE
FREQ

This softkey is valid only for the s domain. In the s domain, it allows you to enter the scaling frequency. This frequency is multiplied by the values in the table to scale the x-axis up or down in frequency without having to change every value. This allows you to change horizontal scaling (for example, frequency) without scaling the amplitude.

The frequency can be entered in Hz; the range is 10^{-6} to 10^{+6} . The default value is 1 Hz/Hz (i.e. unitless, even though the units key is used to complete numeric entry).

An example use of scale frequencies is entering normalized values from a filter design handbook then translating the function to the desired range.

The scale frequency feature can also be used to scale s-domain values (pole-zeros) from radian per second to Hz by setting the scaling value to $1/(2\pi)$. Or, you could use the scale frequency feature to enter normalized values from a filter design handbook, then translate the function to the desired range. The following are identical:

Hz	Scale Freq	Gain
Pole at -1	1	1

Radians	Scale Freq	Gain
Pole at - 6.28318	0.159155	6.28

The pole is entered as - 6.28 Hz but with frequency scaling set to $1/(2\pi)$, the pole will appear to be at - 1 Hz, which is - 6.28 radians.

SAMPLE
FREQ

This softkey is valid only for the z domain. It allows you to enter the sample frequency used for z-domain synthesis. It is important to know that z-domain synthesis does not use the measurement sample frequency (set with **FREQ** or **INPUT CONFIG**). Instead, z-domain synthesis uses the sample frequency specified with this key. If you want z-domain synthesis to use the measurement sample frequency, press **MEAS CLOCK** (see the description that follows). The value that you enter for **SAMPLE FREQ** does not change the measurement sample frequency — it only changes the sample frequency in the z-domain synthesis table.

The synthesis is performed over the selected measurement frequency-span. With external sampling, the maximum span is 1/2 the sampling frequency if the **LINES** softkey (in the **WINDOW** menu) is set to 1024.

MEAS
CLOCK

This softkey is valid only for the z-domain. When this key is active, z-domain synthesis uses the measurement sample frequency (set with **FREQ** or **INPUT CONFIG**) instead of the sample frequency specified with **SAMPLE FREQ**.

The synthesis is performed over the selected measurement frequency span. With external sampling, the maximum span is 1/2 the sampling frequency if the **LINES** softkey (in the **WINDOW** menu) is set to 1024.

Z PWR
+ -

This softkey is valid only for the z domain. It changes the power of z in the synthesis table. The softkey's current selection (+ or -) is highlighted on the softkey and appears in the status line of the table (lower right hand corner).

This softkey should be set before editing an empty synthesis table. To change the power of z for a Pole Zero table, a Polynomial table, or an empty Pole Residue table, press the Z PWR key which will toggle z to the other sign. However, if you are using a Pole Residue table which has entries, you must manually change the z power by converting to a different data format (using the **CONVRT TABLE** softkey), change the z power, and then convert back to the Pole Residue form (using the **CONVRT TABLE** softkey).

Caution

Be aware that use of **CONVRT TABLE** more than once will introduce numerical truncation and roundoff errors which can corrupt the results. Save the original table on a disk.

Furthermore, **CONVRT TABLE** is the only feature that changes the data format without erasing the synthesis table. If you use one of the other data format softkeys to change the data format (such as **POLE ZERO**), the contents of the synthesis table are erased. In this case you will see the message **EDIT ERASES LAST TABLE** in the status line of the display (lower right-hand corner). To cancel, press return. See "Converting Data Formats" for details.

GAIN FACTOR: Analog Circuits

The following example shows you how to use GAIN FACTOR for an analog circuit. Assume that you want to synthesize a 20 kHz low-pass filter (single pole) that has the following equation:

$$H(s) = \frac{1}{s + 20000}$$

The equation shows a pole (in pole-zero format) at -20 kHz. Therefore, enter a pole in pole-zero format at -20 kHz. It also yields a pass band gain (at 0 Hz) of $1/20000$ (-86 dB). To obtain a gain of 0 dB, press GAIN FACTOR, then enter 20000. This changes the equation to:

$$H(s) = \frac{20000}{(s + 20000)}$$

Now the gain is 1 (0 db) at 0 Hz.

GAIN FACTOR: Digital Circuits

The following example shows you how to use GAIN FACTOR for a digital circuit. Assume that you want to synthesize a low-pass digital filter (single pole) that has the following equation:

$$H(z) = \frac{1}{(z - 0.3)}$$

The equation shows a pole (in pole-zero format) at + 0.3. Therefore, enter a pole in pole-zero format at + 0.3.

To obtain the frequency response, you must replace z with $e^{j2\pi fT}$ in the frequency response calculation. At 0 Hz (where $f = 0$), this equals 1. Thus, at 0 Hz, the dc gain is computed as follows:

$$\frac{1}{(1 - 0.3)} = 3.098 \text{ dB}$$

To obtain a gain of 1 (0 dB), press GAIN FACTOR and enter the value 0.7 (using the Entry group keypad). This changes the equation to:

$$H(z) = \frac{0.7}{(z - 0.3)}$$

The gain is now 1 (0 dB) at 0 Hz.

Convert to s Menu

The convert to s menu lets you convert a synthesis table from the z domain to the s domain. This menu appears when you press **SYNTH CONVRT TO S**. The **CONVRT TO S** softkey appears only when the domain is z (in other words, when **DOMAIN S Z** is toggled such that **Z** is highlighted). If the s domain is selected, this softkey reads **CONVRT TO Z**. When you press **CONVRT TO S**, the following softkeys appear:

**BI-
LINEAR** Converts the current s-domain synthesis table into the z- domain using the Bilinear Transformation. The results are placed into the z-domain synthesis table leaving the s-domain table unchanged. The Bilinear transformation maps s poles in the left-half-plane into z poles inside the unit circle. Therefore, it maps stable systems in the s-domain to stable systems in the z-domain.

There is no aliasing with this transformation. However, the frequency mapping is non-linear. Frequency pre-warping is provided. See the description of the **P WARP** softkey. The sample frequency in the z-domain table is used in computing this transformation.

**P WARP
ON OFF**

Selects the frequency pre-warping feature for the Bilinear transformation. The softkey toggles between the **ON** and **OFF** position. The default is **OFF**. When pre-warping is off, the amplitude of the s-domain frequency response matches the amplitude of the z-domain frequency response at dc and remains close at low frequencies. However, warping accelerates as you approach $F_s/2$. To match the amplitude of the frequency response at a specific frequency in the s and z domains, press the softkey to the **ON** position and specify the frequency with the **FREQ WARP** softkey.

**STEP
INVRNC**

Converts the current s-domain synthesis table into the z- domain using the Step Invariance Transformation. The sample frequency in the z-domain table is used in computing this transformation. The results are placed into the z-domain synthesis table leaving the s-domain table unchanged. The numerator order must be less than or equal to the denominator order.

The z-domain frequency response is formed by the replication of the continuous s-domain response at multiples of F_s . A $1/s$ term is multiplied by $H(s)$ before the conversion and then multiplied by $(z-1)/z$ after the conversion to compensate for the $1/s$ continuous step. Unless $H(s)$ is bandlimited to $F_s/2$, aliasing is evident in the $H(z)$ frequency response near $F_s/2$.

For more information about this transformation, refer to the application note, "Fundamentals of the z-Domain and Mixed Analog/Digital Measurements", in the *HP 3563A Getting Started Guide*.

IMPULS
INVRNC

Converts the current s-domain synthesis table into the z-domain using the Impulse Invariance Transformation. The sample frequency in the z-domain table is used in computing this transformation. The results are placed into the z-domain synthesis table leaving the s-domain table unchanged. The numerator order must be less than or equal to the denominator order.

The z-domain frequency response is formed by the replication of the continuous s-domain response at multiples of F_s . Unless $H(s)$ is bandlimited to $F_s/2$, aliasing is evident in the $H(z)$ frequency response near $F_s/2$.

For more information about this transformation, refer to the application note, "Fundamentals of the z-Domain and Mixed Analog/Digital Measurements", in the *HP 3563A Getting Started Guide*.

SAMPLE
FREQ

Enter the sample frequency to be used for the digital filter designed by the transform. The higher the sample frequency, the further the analog response that can be uniquely represented in the periodic z domain filter response. After conversion, this sample frequency will be displayed in the z domain synthesis table.

MEAS
CLOCK

Highlight this softkey if you wish to have the measurement sample frequency used for the z domain design. After conversion, this sample frequency will be displayed in the z domain synthesis table.

The Bilinear, Step Invariance and Impulse Invariance Transformations preserve stability by mapping poles in the left-half of the s plane into poles inside the unit circle in the z plane.

Use of the z domain fitter can match gain and phase fairly well up close to the Nyquist rate (one half the sample frequency), but is not guaranteed to give a stable z domain filter design. See chapter 16, and Product Note HP 3563A-1, "z-Domain Curve Fitting in the HP 3563A Analyzer", for further information.

Note

When sample frequency is not specified in the CONVRT TO Z menu, the sample frequency is taken from the current z domain table.

Also, time delay is merely copied from the s domain table into the z domain table; it does not affect the transformation.

Furthermore, the scale frequency is used in the transformation. Refer to the beginning of this chapter for a description of the SCALE FREQ.

This conversion process overwrites any existing z-domain table. If you wish to keep the current z-domain table, save it to a disc. Refer to the description for the SAVE FILE softkey in chapter 11.

Convert to z Menu

The convert to z menu lets you convert a synthesis table from the s domain to the z domain. This menu appears when you press **SYNTH CONVRT TO Z**. The **CONVRT TO Z** softkey appears only when the domain is s (in other words, when **DOMAIN S Z** is toggled such that **S** is highlighted). If the z domain is selected, this softkey reads **CONVRT TO S**. When you press **CONVRT TO Z**, the following softkeys appear:

INVERS BI-LIN	Converts the current z-domain synthesis table into the s- domain using the Inverse Bi-linear transformation. The results are placed into the s-domain synthesis table leaving the z-domain table unchanged. The sample frequency in the z-domain table is used in computing this transformation. Frequency pre-warping is provided (see the description of the FREQ WARP softkey for details).
P WARP ON OFF	Selects the frequency pre-warping feature for the Inverse- Bilinear transformation. The softkey toggles between the ON and OFF position. The default is OFF . When pre-warping is off, the amplitude of the s-domain frequency response matches the amplitude of the z-domain frequency response at dc and remains close at low frequencies. However, warping accelerates as you approach $F_s/2$. To match the amplitude of the frequency response at a specific frequency in the s and z domains, press the softkey to the ON position and specify the frequency with the FREQ WARP softkey.
FREQ WARP	Specifies the frequency at which the amplitude of the z-domain frequency response matches the amplitude of the s-domain frequency response. Also known in the literature as a frequency pre-warping process. The value is entered in Hz and is not affected by the scaling frequency. The default value, 1 Hz, is an arbitrary value. It is necessary to specify a frequency which is within your frequency span and is less than $F_s/2$.
INVERS STEP	Converts the current z-domain synthesis table into the s- domain using the Inverse Step Invariance Transformation. The results are placed into the s-domain synthesis table leaving the z-domain table unchanged. The sample frequency in the z-domain table is used in computing this transformation.

For more information about this transformation, refer to the application note, "Fundamentals of the z-Domain and Mixed Analog/Digital Measurements", in the HP 3563A Getting Started Guide.

INVERS
IMPULS

This transformation converts the current z-domain synthesis table into the s-domain using the Inverse Impulse Invariance Transformation. The sample frequency in the z-domain table is used in computing this transformation. The results are placed into the s-domain synthesis table leaving the z-domain table unchanged.

For more information about this transformation, refer to the application note, "Fundamentals of the z-Domain and Mixed Analog/Digital Measurements", in the *HP 3563A Getting Started Guide*.

The Inverse Bilinear, Inverse Step Invariance and Inverse Impulse Invariance Transformations preserve stability by mapping poles inside the unit circle in the z plane into poles in the left-half of the s plane. The Inverse Impulse and Inverse Step Invariance Transformations match the samples of the Impulse/Step Response of the continuous (s-domain) system to the Unit/Step Sample Response of the sampled (z-domain) system. The frequency mapping of the Inverse Impulse and Inverse Step Invariance Transformations is linear, however, the frequency mapping of the Inverse Bilinear Transformation is not linear.

Note

The time delay term does not affect the transformation. It is, however, copied into the target table.

Furthermore, the sample frequency, $1/T$, used for these transformations is taken from the current z-domain table.

To enter the desired sample frequency, use the **SAMPLE FREQ** softkey. If you wish to use the measurement clock frequency as the sample frequency, select **MEAS CLOCK**.

This conversion process overwrites any existing s-domain table. If you wish to keep the current s-table, save it to a disc. Refer to the description for the **SAVE FILE** softkey in chapter 11.

Introduction

This section contains three appendices:

- Appendix A: Connector/Indicator Descriptions
- Appendix B: Error & Status Messages
- Appendix C: Menu Diagrams

Appendix A describes all connectors and indicators. It first describes these for the analyzer's front panel, then for the analyzer's rear panel.

Appendix B lists and describes all error and status messages. The descriptions include helpful information to help you fix or avoid errors.

Appendix C contains menu diagrams for all hardkeys. A menu diagram shows all softkeys available when you press a hardkey.

Connector/Indicator Descriptions

Introduction

This appendix contains descriptions of all connectors, indicators, and switches on the HP 3563A (see figure A-1 for locations). The first section in this appendix describes all connectors, indicators, and switches on the analyzer's front panel. The next section describes these for the analyzer's rear panel.

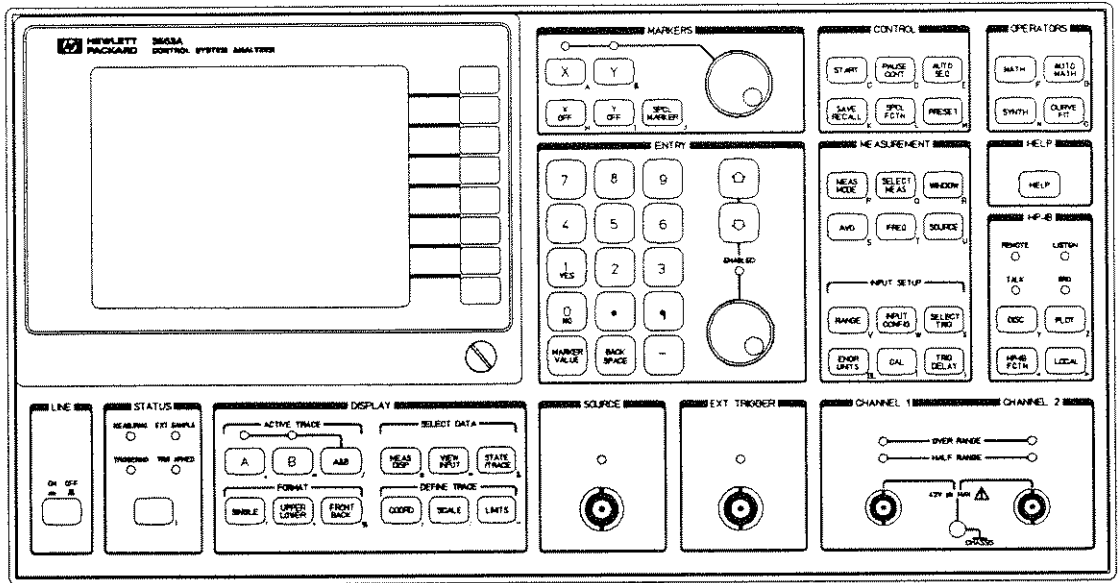

Figure A-1. HP 3563A Front and Rear View

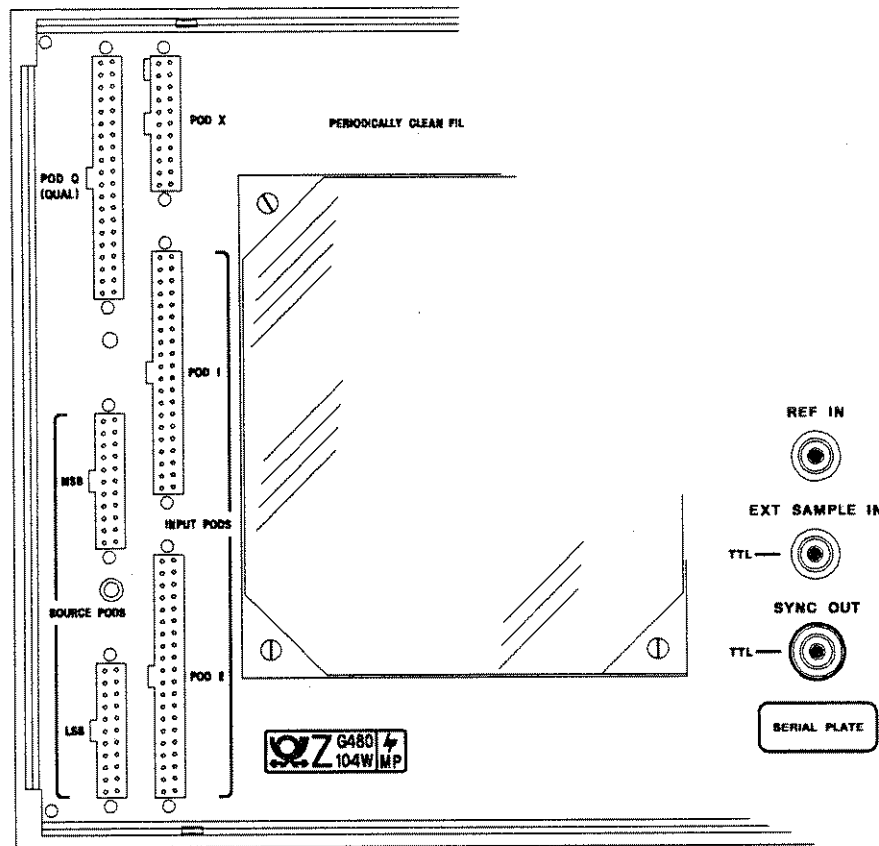

Figure A-2. HP 3563A Connections

Front Panel

This section describes the connectors, indicators and switches on the analyzer's front panel (see figures A-1 and A-2). The descriptions are arranged in alphabetical order.

A (indicator) This LED indicates when trace A is active.

B (indicator) This LED indicates when trace B is active.

CHANNEL 1 (Connector) The maximum input signal level is ± 42 V_{peak}. The input impedance is $1\text{M}\Omega \pm 5\%$, shunted by < 100 pF. The input may be ac or dc coupled as well as grounded or floated.

CHANNEL 2 (Connector) The maximum input signal level is ± 42 V_{peak}. The input impedance is $1\text{M}\Omega \pm 5\%$, shunted by < 100 pF. The input may be ac or dc coupled as well as grounded or floated.

CHASSIS (Connector) Used to connect to the instrument's chassis ground.

ENABLED (indicator) When this LED is on, the Entry group can be used to make numeric entries.

EXT TRIGGER (connector) Used to connect an external trigger signal. This input is enabled when EXT (in the AVG menu) is pressed and the EXT TRIGGER indicator is illuminated. The maximum voltage allowed at this input is ± 10 volts. Note that the external trigger signal level must be at least 200 mV_{pk}. The external trigger signal is subject to the slope and level conditions.

EXT TRIGGER (indicator) This LED indicates that an external trigger signal is expected at the EXT TRIGGER input. When external triggering is active, any signal present at this input is treated as the trigger signal.

HALF RANGE (indicators) These LEDs indicate that the input signal levels on the respective channels are at least half the current input range. To ensure maximum measurement sensitivity and avoid distortion, maintain the input range such that HALF RANGE remains on and OVER RANGE stays off. For more information see **RANGE**.

LINE (switch) Controls ac power to the HP 3563A. When LINE is OFF, all circuits are shut off except the battery backed RAM and circuitry that detects when AC power is supplied to the power supply.

LISTEN (indicator) This LED indicates when the HP 3563A is operating as a listener on the HP-IB.

MEASURING (indicator) This LED indicates when the HP 3563A is measuring data, either input signals or digital data from disc or capture memory.

OVER RANGE (indicators) These LEDs indicate when the analog input-signal level on the respective channel is exceeding the input range. When this occurs, distortion results and measurement quality is degraded. The ideal input range is achieved when HALF RANGE is on and OVER RANGE is off. See Chapter 7 for information on setting the input range or using autoranging. The *over range* indicators are hardwired to the Channel 1 and Channel 2 front panel BNCs. Therefore, if a channel is digital, and you have an analog signal connected to one of these BNCs, the channel's *over range* indicator may light. Since the *over range* indicator is used only for analog data, ignore it when the channel is digital.

REMOTE (indicator) Indicates when the HP 3563A is in the HP-IB remote mode. In this mode, the instrument is under the control of an external controller on the HP-IB. When REMOTE is on, all keys and softkeys (except the **LOCAL** key) are disabled. Pressing LOCAL returns front panel control. However, if a controller has issued the HP 3563A the LOCAL LOCKOUT command, **LOCAL** is disabled, and remains so until the controller issues the GO TO LOCAL command.

SOURCE (connector) Provides the source output signal. The source's output impedance is 50 Ω (nominal). The maximum current is 20 mA.

SOURCE (indicator) This LED indicates when the source output is active. For the burst output types, the LED can be active when no signal is actually present at the output.

SRQ (indicator) This LED indicates when the HP 3563A has issued a service request (SRQ) to the HP-IB. Chapter 6 in the HP 3563A Programming Manual provides information on handling SRQs.

TALK (indicator) This LED indicates that the HP 3563A is in the HP-IB talk mode.

TRIG ARMED (indicator) This LED indicates that the trigger has been armed. If ARM AU MAN is set to AU (auto arm), the trigger is armed automatically. If it is set to MAN (manual arm), the **ARM** key in the Status group must be pressed to arm the trigger. Once it is armed, the trigger will start looking for the trigger signal.

TRIGGERING (indicator) Indicates triggering and trigger signal status. For free run, the LED is on while the time record is being filled. (For real time measurements, it remains on without flashing.) For input channel and external triggering, the LED flashes when the signal is received, if a record is not already in progress. For source triggering, the LED flashes at the beginning of the time record, when the trigger from the source is generated.

Exceptions: For free run and source triggering, the LED does not flash if the measurement is paused. For all triggering modes, the LED does not flash after averaged measurements have been completed.

X (indicator) When this LED is on, the knob in the Markers group moves the X marker and operates with the softkeys in the **X** menu.

Y (indicator) When this LED is on, the knob in the Markers group moves the Y marker and operates with the softkeys in the **Y** menu.

Rear Panel

This section describes the connectors and switches on the analyzer's rear panel (see figure A-2). There are no indicators on the rear panel. The descriptions are arranged in alphabetical order.

DISPLAY OUTPUTS X,Y,Z (connectors) Connects to large-screen displays, such as the HP 1310B.

EXT SAMPLE IN (connector) Used to input sampling signals when the instrument is in external sampling mode. This signal must be TTL-compatible and not greater than 256 kHz. Refer to the descriptions of the E SMPL ON OFF and SAMPLE FREQ softkeys in the FREQ menu for more information.

HP-IB (connector) Connects the HP 3563A to the Hewlett-Packard Interface Bus (HP-IB). For information on using plotters and disc drives, see Chapter 11. For information on programming the instrument with an external HP-IB controller, refer to the HP 3563A *Programming Manual*.

LSB (connector; see chapter 13)

MSB (connector; see chapter 13)

POD 1 and POD 2 (connector; see chapter 13)

POD Q (connector; see chapter 13)

POD X (connector; see chapter 13)

REF IN (connector) Used to phase-lock the HP 3563A to an external clock signal. This reference input replaces the internal 20.48 MHz clock. The signal frequency must be at 1, 2, 5, or 10 Mhz \pm 0.01%. The signal level must be between 0 and 20 dBm. This is a 50 Ω input.

SOURCE PODS (connectors: MSB/LSB; see chapter 13)

SYNC OUT (connector) This output provides a TTL-level signal synchronized to the source. When the burst chirp or burst random is active, the duty cycle of the SYNC OUT square wave equals the burst percentage. (This is the signal that controls the bursts.) When random noise, periodic chirp or fixed sine is active or the source is off, the duty cycle of SYNC OUT is indeterminate. Figure A-3 shows the SYNC OUT signal (upper trace) with the burst random source output (lower trace).

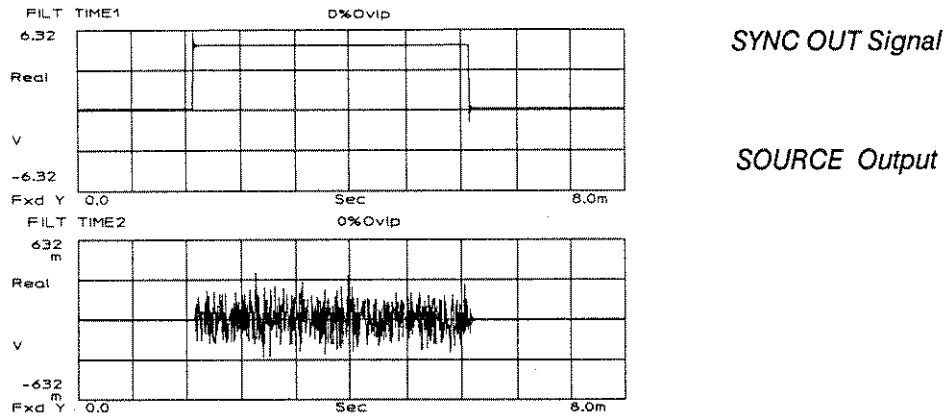

Figure A-3. The SYNC OUT Signal

VOLTAGE SELECTOR (switch) Selects 115 or 230 volt operation. Refer to the *HP 3563A Installation Guide* for instructions on setting this switch and selecting the proper fuse for each setting.

Connector/Indicator Descriptions
Rear Panel

Error And Status Messages

Introduction

This appendix provides explanations of the error and status messages displayed by the HP 3563A. Error messages are displayed when the analyzer detects an operator error. Status messages are displayed during various operations to inform you of the analyzer's status. The first part of this appendix lists the error messages alphabetically with explanations. The second part of this appendix lists the status messages alphabetically with explanations.

Error Messages

This section explains error messages generated by the HP 3563A. Error messages are displayed in the lower left corner of the display, just above the command echo line. Errors are accompanied by an audible beep (if **SPCL FCTN BEEPER ON OFF** is ON).

If the corrective action is not obvious from the displayed message, refer to the descriptions that follow. The number following each message is the error code returned on the HP-IB with the **ERR?** command. The error message falls into six categories, according to number:

1. 100—199: Execution errors
2. 200—299: Command errors
3. 300—399: Parameter errors
4. 400—499: HP-IB errors
5. 500—599: Plotter errors
6. 600—699: Disc errors

The error explanations give you one of two types of corrective action. If the operation you attempted is fundamentally valid, but the details were not correct, you are told how to correct the command. An example of this is the “Out Of Range” error. The entry you are attempting is probably valid, you have just exceeded its limits.

If the operation you are attempting is not valid at all, you are given suggestions for avoiding the error. An example of this is the “Function Inactive” error. You are trying to activate a function that is incompatible with the current instrument state — selecting triggering while in the swept sine mode, for example.

Alpha Too Long (303)

Occurs when an alpha entry greater than 45 characters is attempted.

To avoid this error, keep alpha entries shorter than 45 characters.

Already Running (137)

Occurs when a curve fit is in progress and START FIT is pressed.

To avoid this error, do not press START FIT while a curve fit is in progress. Press STOP FITD if you want to stop the current fit.

Auto Carrier Selected (308)

Occurs when a demodulated measurement is started and a user carrier is selected that is outside the current measurement span. The analyzer has selected AUTO CARRIER for you.

To avoid this error, activate AUTO Carrier or enter a user carrier that is inside the current span.

Auto Order Bounds Invalid (162)

In curve fit auto-order, the numerator order cannot be greater than the denominator order. See chapter 16, "Curve Fit", for additional details.

Bad Auto Sequence table (120)

Occurs if an error is detected when an auto sequence table is being validated. This can happen at power-on and when recalling an auto sequence from disc. The table cannot be recovered.

To avoid future errors, several things should be checked. If the error message was displayed at power-on, either power was lost while the auto sequence was being created or transferred, or the nonvolatile battery needs replacement (servicing required).

If the error message was displayed during recall, power may have been lost while the auto sequence was created or transferred, there may be a problem with your HP-IB cabling, or the storage medium may need replacing.

Bad Capture (131)

This occurs when recalling a capture from disc and the header is not valid. The capture data cannot be recovered.

To avoid future errors, change your storage medium.

Bad Curve Fit table (130)

Occurs when recalling a curve fit table from disc and the table is not valid. The table cannot be recovered. To avoid future errors, change your storage medium.

Bad Data Block (123)

Occurs when a data block is loaded into the analyzer that is not valid.

To correct this error, verify that the data block you are trying to load meets the requirements of the load command you are using. Chapter 3 in the HP 3562A Programming Manual explains the use of the data transfer commands. If the block was dumped from the analyzer, verify that it was not corrupted while in storage; there may be a problem with your HP-IB cabling or medium.

This error also occurs if you try to curve fit a trace that is not a measured or synthesized frequency response function.

Bad Data Header (124)

Occurs when a data block is loaded into the analyzer and the header for that block is not valid.

To correct this error, verify that the header associated with the data block you are trying to load meets the requirements of the load command you are using. Chapter 3 in the HP 3563A Programming Manual explains the use of the data transfer commands. If the block was dumped from the analyzer, verify that it was not corrupted while in storage; there may be a problem with your HP-IB cabling or medium.

Bad Delete Frequency table (140)

Occurs when a delete frequency table is loaded into the analyzer that is not valid. The table cannot be recovered.

To avoid future errors, several things should be checked. Power may have been lost while the table was created or transferred, there may be a problem with your HP-IB cabling, or the storage medium may need replacing.

Bad Nonvolatile State (122)

Occurs at power-on if the nonvolatile state is not valid. The “non-volatile state” comprises those parameters stored in nonvolatile memory and not affected by power-down or presetting (HP-IB addresses, for example). The bad variables cannot be recovered.

To avoid future errors, two things need to be checked. The nonvolatile battery needs replacing (servicing required), or power was lost while one of the nonvolatile parameters was being updated.

Bad # of Parameters (307)

Occurs when you attempt to enter an incorrect number of parameters for the current entry (e.g., entering three variables when only two are requested).

To correct this error, review and correct the entry requirements for the current entry. The command echo field in the lower left corner of the screen shows the number of parameters expected for each entry.

Bad Plotter Data Read (500)

Occurs when START PLOT, READ PEN → P1 or READ PEN → P2 is pressed and the analyzer receives bad data from the plotter.

To correct the error, reset the plotter first by cycling power. If this does not correct the error, check the HP-IB cabling. If this does not work, the plotter is in need of servicing.

Bad Primitive Block (134)

Occurs when a primitive block is loaded into the analyzer and its header is not valid, the amount of data is too long for the block, or the block number is out of range.

To correct the error, verify that the block meets the requirements for primitive blocks. Chapter 4 in the HP 3563A Programming Manual explains these requirements.

Bad Setup State (119)

Occurs if an error is detected when the instrument state is being validated. This can happen at power-on and when recalling a state. The state cannot be recovered.

To avoid future errors, several things should be checked. If the error message was displayed at power-on or when recalling from internal memory, either power was lost while the state was being changed or transferred, or the nonvolatile battery needs replacement (servicing required).

If the error message was displayed during recall from disc, power may have been lost while the state was being changed or transferred, there may be a problem with your HP-IB cabling, or the storage medium may need replacing.

Bad Synth table (121)

Occurs if an error is detected when the synthesis table is being validated. This can happen at power-on and when recalling the table from disc. The table cannot be recovered.

To avoid future errors, several things should be checked. If the error message was displayed at power-on, either power was lost while the table was being changed or transferred, or the nonvolatile battery needs replacement (servicing required). If the error message was displayed during recall from disc, power may have been lost while the table was being changed or transferred, there may be a problem with your HP-IB cabling, or the storage medium may need replacing.

Bad Thrupt (132)

This occurs when a throughput file is measured from disc and its header is bad or the file is empty. The file may be recoverable.

To correct the error, fill the file with data (use START THRUPT), then try to measure it again. If this does not correct the problem, the header is bad and the file cannot be recovered. In this case, to avoid future errors, several things should be checked. Power may have been lost during the throughput session, there may be a problem with your HP-IB cabling, or the storage medium may need replacing.

Buffer Overflow (106)

Occurs when more characters are entered into a display buffer than it was specified to hold. To correct the error, compare the DBSZ statement for the buffer in question with all subsequent display commands in that buffer. Then either increase the buffer size or eliminate some of the buffer's commands.

Calibration in Progress (148)

Occurs when attempting any operation while calibration is in progress.

To avoid this error, wait until calibration is finished.

Cannot Be Complex (139)

Occurs when you attempt to convert a polynomial synthesis table containing complex coefficients to another type.

To avoid the error, do not attempt to convert complex polynomial tables. To be converted, coefficients must be real-only.

Cannot Recall Thruput (600)

Occurs if you attempt to recall a throughput file. These can be measured from disc when throughput is active only — they cannot be recalled as other disc files can.

To avoid the error, do not specify a throughput file when recalling a file from disc. If you want to measure the file, specify it as the active file. Chapter 9 shows the steps required for throughput measurements.

Can't Cnvrt Empty Table (158)

In synthesis, you can't convert a synthesis table (by pressing CONVRT TABLE) that has no data.

Catalog Full (603)

Occurs when attempting to save, create or copy a file on disc and there is no room for another catalog entry. This differs from the "Disc Full" error in which there is no more space for data.

To avoid the error, switch to another disc. Once a catalog has been initialized, there is no way to request more catalog space without erasing the entire disc. If you need to store or create the file on this particular disc, you can delete another file then pack the disc to recover another entry. Depending on the number of sectors already deleted, you may be able to pack without deleting any more.

Catalog Not In Memory (617)

Occurs when you attempt to activate the disc catalog pointer and no catalog file has been read from disc (or it has been erased).

To avoid this error, read the disc catalog (press VIEW CATLOG in the DISC menu) before attempting to activate the pointer.

Cannot Use Zoom Data (136)

Occurs when attempting to use a zoomed throughput file as the source for a log resolution measurement.

To avoid this error, use only baseband throughput files for log resolution measurements.

Command Too Long (203)

Occurs when an HP-IB mnemonic is received that contains more than four alpha characters.

To correct this error, review and correct the syntax for the command in question.

Conversion Error (163)

Numerator order is greater than denominator order. Make sure the numerator order is less than or equal to the denominator order.

Conversion Error (-Zpwr) (164)

In -Zpower and when converting from the z domain to the s domain using the Inverse Impulse Invariance or Inverse Step Invariance conversion methods, this error occurs when there are more zeros than poles in the z-domain table. The number of zeros in the z-domain table must be less than or equal to the number of poles.

Cross Corr, No 1 Ch Demod (103)

Occurs when the cross correlation measurement is selected and you are demodulating on only one channel.

To avoid the error, turn demod off, activate DEMOD BOTH (in the DEMOD SELECT menu), or choose a single-channel measurement.

Data Blocks Incompatible (113)

Occurs when an operation is requested that is incompatible with the specified blocks (complex division on real blocks, for example).

To avoid the error, review the requirements for the signal processing command in question and specify data blocks accordingly. Chapter 4 in the HP 3563A Programming Manual explains the requirements of each command.

Data Type Incompatible (112)

Occurs when an operation is requested and the data blocks involved are incompatible (different number of points or different data types, for example). To avoid the error, review and modify the attempted operation or the blocks involved.

Do Manually For Pole-res (157)

In synthesis, occurs if you try to change from +Zpower to -Zpower when data is in pole-residue format. See "Entering Pole-Residue Data: -Zpower" in chapter 17 for additional details.

Alpha Delimiter Expected (204)

Occurs when an alpha entry is attempted via HP-IB and the command was not terminated by an acceptable delimiter (pair of double quote marks (".") or a single quote (') — it must match the opening delimiter. To correct this error, review and correct the delimiter used.

Demod in Zoom Only (142)

Occurs when a demodulation measurement is attempted and the start frequency is 0 Hz (i.e., baseband).

To avoid the error, set the start frequency to any nonzero value.

Destination Too Small (624)

Occurs when attempting an image backup where the destination disc or tape is too small to receive the entire data image of the source.

To avoid the error, replace the destination with one having at least the same storage capacity as the source. You can also selectively copy files to the destination until it is full.

Disc Fault (613)

Occurs when a disc access is requested and a disc drive failure is detected.

To correct the error, view the disc status display to determine the cause of the failure. Refer servicing to qualified personnel.

Disc Full (607)

Occurs when attempting to save, create or copy a file on disc and there is not enough data space available. To avoid the error, you have several options. First, switch to another disc. Second, delete files from the disc then pack it to reclaim data space. (Depending on the number sectors already deleted, you may be able to just pack without deleting any more.) Third, when creating throughput files, you may be able to reduce the file size and fit a smaller file on the disc.

Disc Reject (608)

Occurs when a disc access is requested and the disc rejected the access.

To correct the error, view the disc status display to determine the source of the error. If necessary, refer servicing to qualified personnel. You should also check the HP-IB cabling and other devices on the bus.

Disc Transfer Error (614)

Occurs when a disc access is requested and the data did not get transferred to disc correctly (such as an aborted throughput).

To correct the error, view the disc status display to determine the source of the error. If necessary, refer servicing to qualified personnel. Ignore this if you have just aborted a throughput session.

Disc Write Protected (612)

Occurs when saving or creating a file on a disc that is write protected.

To avoid this error, determine why the disc was write protected in the first place. If you then decide you want to write to the disc anyway, remove the write protection according to the instructions in the disc drive's operating manual.

ENTRY Not Enabled (309)

Occurs when attempting to use the Entry group (lower knob, up/down arrows, 0-9 keys or **MARKER VALUE**) and the analyzer has not requested an input. To avoid this error, verify that you have enabled an entry before using the Entry group.

Extra Chars in Command (206)

Occurs when a command line sent over HP-IB has extra characters following a valid command. (For example, SRLV 5V ABC.)

File Not Found (606)

Occurs when recalling or deleting a file from disc and the file cannot be found (or recalling locally and no data was saved).

To avoid the error, verify spelling of the desired file name and verify that it is an HP 3563A file. Chapter 11 has information on file handling.

File Size Not Specified (618)

Occurs when attempting to create a throughput file without first specifying the file size (using THRUPT SIZE).

To avoid this error, specify file size before attempting to create throughput files. If you want to use the previously specified size, press THRUPT SIZE to confirm this, then create the file.

Freq Resp, No 1 Ch Demod (102)

Occurs when the frequency response measurement is selected and you are demodulating on only one channel.

To avoid the error, turn demod off, activate DEMOD BOTH (in the DEMOD SELECT menu), or choose a single-channel measurement.

Function Inactive (207)

Occurs when attempting to activate a function that is incompatible with the current instrument state. To avoid this error, review the function you are trying to activate and the current instrument state to determine the conflict.

Invalid: Log Data (145)

Occurs when special markers are activated with log x-axis data.

To avoid this error, do not attempt special marker functions with log x-axis data.

Invalid: Nichols/Nyquist (144)

Occurs if special markers are activated with Nichols or Nyquist display.

To avoid the error, do not attempt special marker functions on these displays.

Line Too Long (202)

Occurs if an HP-IB command line with greater than 80 characters is sent to the analyzer.

To correct the error, limit your command lines to 80 characters. For example, in BASIC do not send more than 80 characters with the OUTPUT statement.

Loops Nested Too Deep (141)

Occurs when an auto sequence is started then has loops nested greater than three levels deep. To avoid the errors, limit loop nesting to three levels.

Marker Not On (125)

Occurs when the **MARKER VALUE** key is pressed and a marker is not on.

To correct the error, activate a marker or make the entry manually.

May Be Inaccurate (138)

Occurs when the pole/zero finder part of the curve fitter or synth table is slow to converge. This implies that the resulting pole and zero locations may be less accurate than normal.

Measurement in Progress (110)

Occurs when a measurement is in progress and you attempt to activate functions such as auto math, auto sequence and synthesis.

To correct, wait until the measurement is finished, or press **PAUSE CONT** to pause the measurement.

Missing Input (300)

Occurs when the analyzer is expecting a numeric input and you terminate the entry without entering a number. For example, the key sequence MATH: ADD: ENT generates this error.

To correct the error, enter a number before terminating the entry.

No Active Display Buffer (116)

Occurs when attempting to use the graphics commands without first activating a user display buffer. To correct the error, activate a buffer first using DBAC (display buffer active clear) or DBAA (display buffer active append). Chapter 6 in the HP 3563A Programming Manual explains the steps for using display buffers.

No Avg For Demod Hist (149)

Occurs when attempting to average histogram measurements while in demod.

To avoid this error, select AVG OFF

No Capture Data (127)

Occurs when START is pressed in capture mode or you try to enable the capture pointer or change the capture increment and the capture buffer does not contain any captured data.

To avoid this error, avoid these operations until the capture buffer contains valid data as a result of a time capture.

No Carrier (146)

Occurs when attempting the MOD INDEX calculation and the carrier is outside the measurement span. To correct the error, enter a carrier that is inside the current frequency span.

No Coord Change Allowed (107)

Occurs when attempting to select display coordinates for the ORBITS T1vsT2 or DEMOD POLAR displays. To avoid this error, do not attempt to change the coordinates on these displays: they are not user-definable.

No Data (109)

Occurs when there are no valid data for the display. To correct, put a data trace on the display using the Display group of keys.

No Dig Src In Src Protct (152)

Source protection cannot be activated when the source is digital.

No Disc In Drive (611)

Occurs when a disc access is attempted and there is no disc in the specified drive unit.

To correct this error, insert a disc if the drive is empty or verify the disc address and unit number to make certain the analyzer is accessing the drive you want it to access.

No From Src In Mix Ratio (161)

Channel 1 cannot be connected to the analyzer's internal source if the sample clock mixed-ratio is greater than 1.

No Fundamental (104)

Occurs when attempting the THD calculation and the fundamental frequency is outside the measurement span.

To correct the error, enter a fundamental that is inside the current frequency span.

No Input Trg On Dig Chan (154)

CHAN 1 INPUT trigger is not allowed if Channel 1 is digital. Likewise, CHAN 2 INPUT trigger is not allowed if Channel 2 is digital.

No Peak Avg in CORR Meas (101)

Occurs when a correlation measurement is selected and peak hold or continuous peak averaging is active.

To avoid this error, do not use these combinations of measurement and averaging type. Peak averaging applies only to frequency domain measurements.

No Peak Avg in HIST Meas (100)

Occurs when the correlation measurement is selected and peak hold or continuous peak averaging is active.

To avoid this error, do not use these combinations of measurement and averaging type. Peak averaging applies only to frequency domain measurements.

No Peak Hold In Time Avg (147)

Occurs when attempting peak hold averaging when time averaging is ON.

To avoid this error, turn time averaging OFF.

No Protct In More Src (156)

Source protection cannot be activated when the source type is PULSE, STEP, RAMP, or USER SAVD 2.

No Src Protct In Dig Src

Source protection cannot be activated when the source is digital.

No Spares or Fault Area (615)

Occurs when attempting to spare block on a medium that has no remaining spares, or a fault has occurred and the disc has no room to record it.

To avoid this error, do not attempt to spare blocks on such media. NOTE: Any medium that does not have any spares or fault area available should be backed up and replaced.

No Thrupt Data (128)

Occurs when THRUPT TIME 1, THRUPT TIME 2 or NEXT RECORD is pressed and there are no throughput data in the throughput file for that channel. To avoid the error, throughput on the desired channel or do not try to display it.

No Thrupt File (616)

Occurs when attempting a throughput session 0 measurement, when reading the throughput header, or when using the THRUPT TIME 1 and 2 softkeys and the specified active file cannot be found. To correct this error, either specify a valid active file or create a throughput file under the desired name.

No Valid Marker Units (126)

Occurs when MARKER VALUE is used to make an entry and the marker units do not match those requested by the analyzer.

To correct the error, change the units to match the units requested (may not be possible) or make the entry manually.

Not a Valid Auto Math (118)

Occurs when AUTO MATH is selected as a measurement display and the auto math table contains keys or softkeys other than **A**, **B**, **A&B**, **MATH** and its softkeys, or **MEAS DISP** and its softkeys (or a **MATH** softkey after **MEAS DISP**).

To correct the error, edit the auto math table to remove all commands that are not valid. An "R" is displayed by each line in the listing that generated an error.

Not A Valid Block Length (400)

Occurs when the length of a block is ≤ 0 or > 32767 bytes. Length is specified by the 16-bit word following the mode indicator (#A or #I).

To correct the error, review the transfer you are attempting and change either the length word or the mode indicator of the block.

Not a Valid Block Mode (401)

Occurs when an invalid data format is used for data transfers to or from an external controller. Only #A (ANSI and internal binary) and #1 (ASCII) block modes are allowed.

To avoid the error, do not attempt transfers using invalid data formats.

Not A Valid Catalog (601)

Occurs when attempting to read a catalog that is not valid. This could be a result of data corruption on the medium, power loss during a data access, or using a medium that has been formatted but has not had a catalog initialized on it.

To correct this error, first verify that it is the proper disc, then restore or initialize the catalog as necessary.

Not a Valid Display (605)

Occurs when attempting to save a display to disc that cannot be saved (a disc catalog, for example).

To avoid the error, change the display before attempting to save it.

Not a Valid Number (302)

Occurs when entering a numeric parameter that is not a valid number. For example, the entry 5..0 generates this error.

To correct the error, match the entry format required for the current parameter. The requirements of each entry are displayed in the command echo line in the lower left corner of the display.

Not a Valid Name (604)

Occurs when specifying a disc file or volume name that is not compatible with Hewlett-Packard's Logical Interchange Format (LIF) or the requirements of the HP 3563A.

To avoid the error, make sure your file names start with an alphanumeric character (0-9, A-Z) and include only alphanumerics and underscores. Disc file names are limited to eight characters. Volume names (INIT CATLOG & INIT DISC), must start with a letter (A-Z), cannot contain underscores, and are limited to six characters.

Not a Valid Terminator (205)

Occurs when a command with a number was entered and it was not properly terminated. To correct the error, review the syntax of the command in question. Entries that are terminated by the ENTER or ENT softkeys do not require termination over the bus; all other entries need a terminator. For example, NAVG10 (number of averages) is valid, but CF10 (center frequency) is not.

Not a Valid User Window (133)

Occurs when the user-defined window is selected and the SAVED DATA#1 area does not contain a real-only time domain function.

To correct this error, replace the function in SAVE DATA#1 with a valid windowing function or switch to another window type.

Not Active Softkey (200)

Occurs when making a selection via HP-IB and the function in question is not active. For example, you cannot clear an auto sequence without first selecting and displaying it.

Not HP-IB Controller (402)

Occurs when attempting to copy files or output command strings while the analyzer is in addressable-only mode.

To correct this error, select SYSTEM CNTRLR before starting these operations.

Not in Frequency Domain (108)

Occurs when the sideband or harmonic markers are activated and the active trace is not in the frequency domain. The markers remain active, but will not be displayed until you change the trace to the frequency domain.

To avoid the error, turn the markers off or switch to a frequency domain display.

Not Valid Binary Digit (302)

For qualifiers, only "0", "1", and "X" are valid digits. See the description of the CLOCK QUALFR softkey in chapter 7 for additional details.

Not Valid For This Disc (623)

Occurs when attempting disc service diagnostics on disc drive command sets not supported by the HP 3563A.

To avoid this error, use the disc servicing diagnostics only with Hewlett-Packard Command Set/80 and Subset/80 disc drives. Note that some of the SS/80 diagnostics are not implemented.

Not Valid Format Option (622)

Occurs when selecting a Subset/80 format option that is not valid for this disc.

To correct the error, refer to your disc drive's manual for acceptable values.

Not Valid In Src Protct

The following source types are not available when source protection is ON: PULSE, STEP, RAMP, and USER SAVD 2. This is true when the source is analog or digital.

Not Valid Units (301)

Occurs when a frequency or time entry is made with a terminator that is incompatible with the sampling units. For example, entering frequency in orders while in internal sampling.

To correct the error, use compatible units or change the sampling mode.

Number Too Long (304)

Occurs when a number greater than 24 characters is entered.

To correct the error, limits numeric entries to 24 characters.

Numeric Overflow (143)

Occurs when the floating point representation of a two's complement 16-bit integer is too large in a transferred block.

To correct the error, review the data format being used and constrain all data to that format.

Out Of Range (305)

Occurs when the attempted entry is outside the allowable range of the current entry function.

To correct this error, constrain the entry to the limits allowed for the current function.

Recall Active Auto Seq (609)

Occurs when an auto sequence is recalled from disc into an auto sequence that is currently running. Either the auto sequence recalled itself or recalled another auto sequence into its own table.

To avoid the error, remove or modify the recall command that caused the error.

Recursive Call (117)

Occurs when an auto sequence calls itself, either directly or indirectly.

To avoid the error, remove or modify the command that caused the error. If you need to loop an auto sequence, use the LOOP TO or GO TO softkey.

Sector Size 256 Bytes (621)

Occurs when attempting to access a disc with sector size other than 256 bytes.

To avoid this error, use only discs that are formatted at 256/bytes sector. This is the only sector size compatible with the HP 3563A. (See the "Formatting Discs" in chapter 11.)

Select Capture to Recall (619)

Occurs when trying to recall a capture file from disc and the analyzer is not in the time capture mode.

To correct the error, first verify that this is the file you want to recall. If so, select the time capture mode (press **MEAS DISP** followed by **TIME CAPTUR**) before attempting to recall it.

Source Block Empty (114)

Occurs when attempting a signal processing operation and the source data block is empty.

To correct the error, fill the source block first or avoid the operation.

Source = Destination (620)

Occurs when attempting a file copy or image backup and the source address and unit match the destination address and unit (you cannot copy or backup a disc to itself).

To correct this error, review the source and destination addresses and unit numbers and change them so they are no longer equal.

Table Overflow in Convrt (150)

In synthesis, occurs when you try to change from +Zpower to – Z power (and vice-versa) and there is not enough space in the synthesis table. See “Performing the Synthesis With a – Zpower” with pole-zero data in chapter 17 for details.

Thrupt Data Too Long (129)

The active throughput file is not large enough to accept the session length you have set up.

To correct, set the session length equal to or smaller than the file size. Remember that two-channel sessions require twice the number of records. Also, if you have changed the frequency span, session length entries in units of time may no longer be valid because the corresponding record length has changed.

Trace Not Compatible (111)

Occurs when attempting math operations on traces that are not compatible.

To correct, review the desired operation and the traces involved to see if they are compatible. For example, you cannot add a frequency domain trace to a time domain trace. Chapter 15 has more information.

Unable to Curve Fit (306)

Occurs when a frequency response measurement is so poor in quality that the curve fitter is unable to fit it. Can also occur if the curve fit is set up incorrectly.

To correct the error, use a better-quality frequency response and review your curve fit setup.

Unformatted Disc (602)

Occurs when attempting to access a disc that has not been formatted.

To correct this error, format the disc (using INIT DISC) before attempting data accesses to it.

Unknown Disc Command Set (610)

Occurs when attempting to access a disc drive whose command set is not supported by the HP 3563A. Hewlett-Packard Command Set/80, Subset/80, and Amigo command sets are supported.

To avoid the error, use only supported disc drives.

Unknown Mnemonic (201)

Occurs when sending an HP-IB command the analyzer does not recognize.

To correct this error, review the command string that generated the error message and change the incorrect mnemonic.

User 2 Not Valid For Src (153)

The trace in user saved #2 is not a valid user source. A user source must be a 2048 point real (not complex) time record. See the description of the arbitrary source in chapter 3 for additional details.

User Display Not Enabled (115)

Occurs when attempting to send display graphics commands without first creating and activating a display buffer.

To correct the error, first create a buffer with DBSZ then activate it with DBAC. Chapter 5 of the HP 3563A Programming Manual explains the steps needed to generate custom displays.

View Input Disabled (135)

Occurs if you try to view the input signals during a capture or throughput measurement. The input channels are disabled while you are measuring captured data from the time buffer or throughputted data from a disc file.

To avoid the error, don't try to view the input signals during capture or throughput measurements.

X Marker Must be Active (105)

Occurs when one of the read X marker commands is sent to the analyzer and the X marker is not on. To correct this error, activate the X marker before using RDMK.

Status Messages

This section lists and describes the analyzer's status messages. The HP 3563A displays status messages at various times to inform you of its current state. These messages are displayed in the lower right corner of the screen in bold capital letters. The primary purpose of including status messages in this appendix is to refer you to the proper sections in the operating and programming manuals for additional information.

ACCEPT DATA? (YES/NO)

Displayed when manual previewing is active and the analyzer is waiting for you to accept or reject the displayed record. To accept, press the **YES (1)** key. To reject, press the **NO (0)** key (ACPT, REJT from HP-IB). For information on previewing, see chapter 3.

ALPHA MODE

Displayed while the analyzer is in the alpha input mode. This mode is entered automatically whenever an alphanumeric entry is required (after pressing TRACE TITLE, for example). In this mode, the keys (except **LINE**, **HELP** and **0-9**) are converted to their blue labels.

AUTO MATH EDIT

Displayed while the auto math table is being edited. In this mode, any key press is entered in the table. To exit, press END EDIT. Chapter 15 has information on auto math.

AUTO MATH LOAD

Displayed while the auto math table is being loaded from the analyzer's internal memory. The contents of the table are listed on the display. Chapter 15 has information on auto math.

AUTO MATH RUNNING

Displayed while the auto math table is running. Chapter 15 has information on auto math.

AUTO SEQUENCE EDIT

Displayed while an auto sequence table is being edited. In this mode, any key press is entered into the auto sequence. To exit, press END EDIT. Chapter 10 has information on auto sequences.

AUTO SEQUENCE LOAD

Displayed while an auto sequence is being loaded from internal memory. The contents of the auto sequence are listed on the display. Chapter 10 has information on auto sequences.

AUTO SEQUENCE RUNNING

Displayed while an auto sequence is running. Chapter 10 has information on auto sequences.

BINARY

When entering data for qualifiers (using the CLOCK QUALFR softkey), you can only enter binary data (represented as a "0", "1", or "X" [don't care]).

CALCULATION IN PROGRESS

Displayed while lengthy math calculations are in progress. Chapter 15 has information on waveform math.

CALIBRATION IN PROGRESS

Displayed while the analyzer is calibrating the inputs. Chapter 7 has information on the calibration feature.

CAPTURE IN PROGRESS

Displayed while a time capture is in progress. The captured time buffer is displayed when the capture is finished. To abort the capture, press ABORT CAPTUR. Chapter 6 has information on the time capture mode.

CREATE WEIGHT

Displayed while the curve fitter is creating a weighting function from the curve fit data. Chapter 16 has information on curve fitting.

CURVE FIT IN PROGRESS

Displayed while a curve fit is in progress. To abort the fit, press STOP FITD. Chapter 16 has information on the curve fitter.

DATA REJECTED

Displayed when a time record has been rejected by the overload rejection feature, indicating that some part of the record exceeded the input range. Chapter 3 has information on overload rejection.

DEMODULATION IN PROGRESS

Displayed while a demodulation measurement is in progress. Because of the number of calculations involved, demodulation measurements require more time than normal linear resolution measurements. Chapter 3 has information on demodulation.

DIAGNOSTIC IN PROGRESS

Displayed while a service diagnostic test is in progress. This occurs in two situations of interest to operators. At power-on, the self test is run and this status message and "Start Pending" are displayed together. As long as the messages disappear and the analyzer starts normal operation, there is no need for concern. The other time it is displayed for operators is after the SELF TEST softkey is pressed. As with power-on, if the message disappears after several seconds, the analyzer is operating properly. However, if a test failure indication is displayed in either case, the analyzer needs servicing. Refer to the HP 3563A Service Manual for more information.

DIGITAL OVER RANGE 1

Channel 1 is digital and it overflowed. This can happen if the data size is 16 bits, the lower 13 bits are selected, and the number overflows the lower 13 bits (i.e. upper 4 bits are not the same value). This can also happen if X OVFL (external overflow) is turned on the channel 1 and this line indicates an overflow.

DIGITAL OVER RANGE 2

Channel 2 is digital and it overflowed. This can happen if the data size is 16 bits, the lower 13 bits are selected, and the number overflows the lower 13 bits (i.e. upper 4 bits are not the same value). This can also happen if X OVFL (external overflow) is turned on the channel 2 and this line indicates an overflow.

DIGITAL OVER RANGE 1&2

Both Channels are digital and the both overflowed. This can happen if the data size is 16 bits, the lower 13 bits are selected, and the number overflows the lower 13 bits (i.e. upper 4 bits are not the same value). This can also happen if X OVFL (external overflow) is turned on a channel and this line indicates an overflow.

EXT REFERENCE NOT LOCKED

Displayed when an external reference signal is applied and the analyzer is not phase-locked to it. Refer to "Ref In (connector)" in Appendix A for the signal requirements.

FAST AVERAGING

Displayed while fast averaging is in effect (the display does not update). Chapter 3 has information on fast averaging.

FILE COPY IN PROGRESS

Displayed while a disc file is being copied. Chapter 11 has more information on file copying.

FILLING TIME RECORD

Displayed when the analyzer is measuring the first record on lower-frequency spans. Partial block FFTs can be displayed while the time record is filling.

FILTERS SETTling

Displayed when the analyzer's digital filter is settling. Averaged measurements do not start until the filters settle. The nominal settling time is 102 points.

FORMAT DISC IN PROGRESS

Displayed while a disc format is in progress. Chapter 11 has information on disc formatting.

HELP MODE, PRESS ANY KEY

Displayed after you press the **HELP** key. The next key or softkey you press will display a description of that feature. The Help mode is exited after each press. Press any key in the Display group to return the previous display.

IMAGE BACKUP IN PROGRESS

Displayed while an image backup is in progress. Chapter 11 has more information on image backups.

MARKER CALC IN PROGRESS

Displayed when lengthy special marker calculations are in progress.

MISSED SAMPLE

Displayed if a sample of the input signal is missed because the external sampling frequency is too high (>256 kHz). Chapters 3, 7, 13, and 14 have information on external sampling.

PACK DISC IN PROGRESS

Displayed while disc is being packed. Chapter 11 has information on disc packing.

PLOT IN PROGRESS

Displayed while a plot is in progress. The plot can be aborted by pressing the **ABORT HP-IB** softkey. Chapter 11 has information on using a plotter.

RAMPING SOURCE

Displayed while the source is being ramped up or down. Refer to "Source Protection" in chapters 3-6, depending on the current mode.

READ ERT IN PROGRESS

Displayed while the read-only ERT is in progress. Chapter 11 has information on the ERT and the other disc servicing features.

RESTORE DISC IN PROGRESS

Displayed while a disc restoration is in progress. Chapter 11 has information on restoring discs.

SWEEP POINT READY

Displayed when the sweep point ready bit in the instrument status register is set and the analyzer is in the addressable-only mode. Chapter 6 in the HP 3563A Programming Manual shows how to read sweep points via HP-IB.

SYNTH TABLE CONVERSION

Displayed while the synthesis table is being converted from one type to another. Chapter 17 has information on synthesis.

SYNTHESIS IN PROGRESS

Displayed after CREATE TRACE is pressed and a frequency response synthesis is in progress. The resultant trace is displayed when the synthesis is finished. Chapter 17 has information on synthesis.

SYSTEM FAILURE

Displayed when a system failure is detected and an error is logged in the fault log. Refer servicing to qualified personnel.

THROUGHPUT IN PROGRESS

Displayed while a throughput session is in progress. Chapter 9 has information on the time throughput feature.

TIMED PREVIEW (YES/NO)

Displayed when timed previewing is active and the analyzer is pausing for you to accept or reject the displayed record. Press **YES (1)** to approve or **NO (0)** to reject. Chapter 3 has information on timed previewing.

WAITING FOR ARM

Displayed when the trigger is waiting to be armed. This occurs when ARM AU MAN is set the MAN (manual arming). To arm the trigger, press the **ARM** key. Chapter 7 has information on manual triggering.

WAITING FOR DISC

Displayed when a disc access is requested and the specified action is not occurring. Press **ABORT HP-IB** to halt access. Chapter 11 has more information on using disc drives. You should also verify your HP-IB addressing and cabling.

WAITING FOR HP-IB

Displayed when the analyzer is waiting for a response from a device on the bus. If necessary, verify your addressing and cabling, then try the operation again.

WAITING FOR TRIG

Displayed when the trigger has been armed (either auto or manually), and it is now waiting for the specified trigger signal conditions (slope and level) to be met. Chapter 7 has information on triggering.

Menu Diagrams

Introduction

This appendix provides diagrams of the HP 3563A's softkey menus. Each diagram is a "map" that allows you to view all the softkeys under a particular hardkey. Several menus are variable (they depend on other softkey selections); in these cases, notes are provided to explain the cause of each variance.

The menu diagrams are arranged in alphabetical order by hardkey.

ALPHA

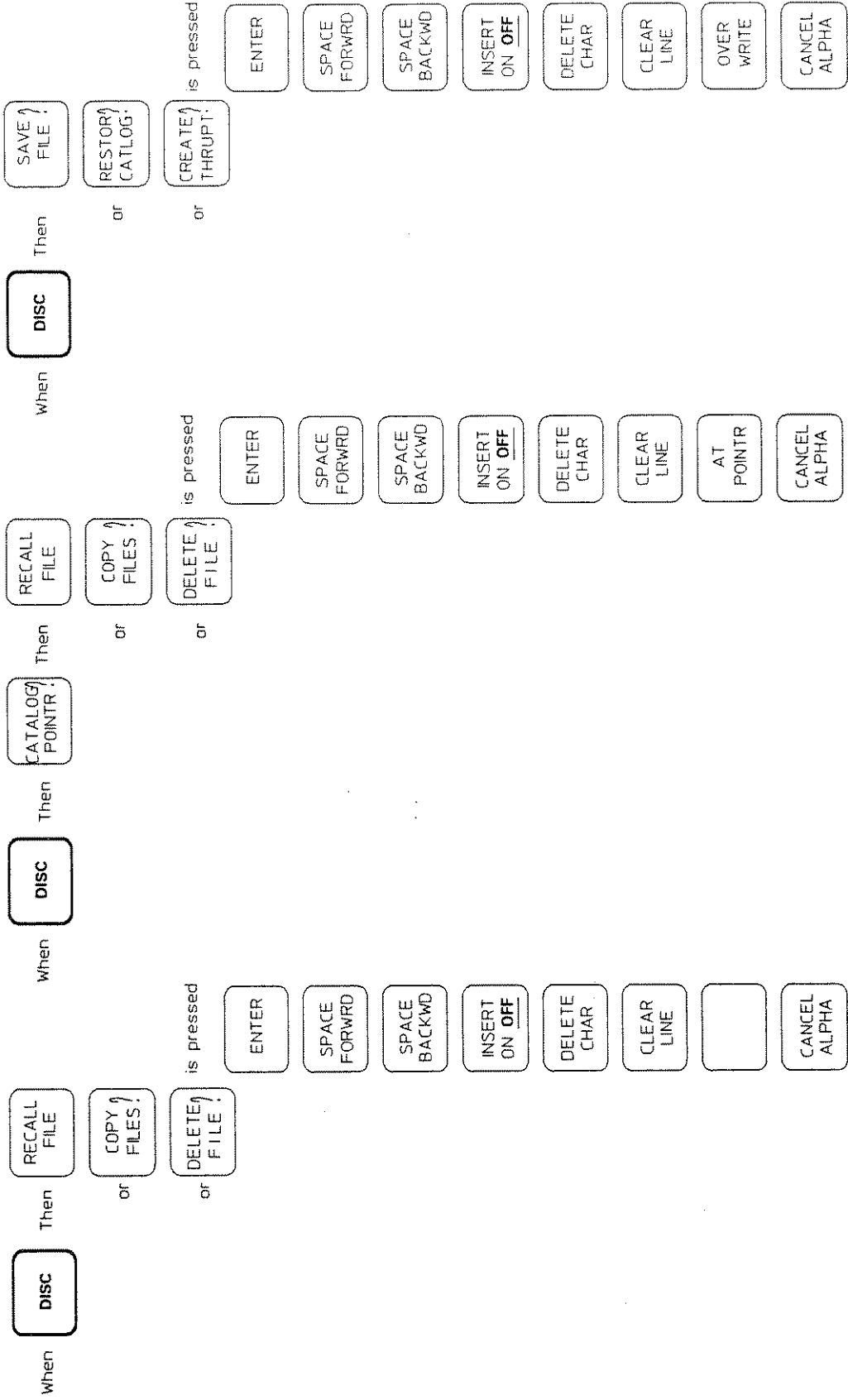

Alpha Menu Diagram

AUTO
MATH

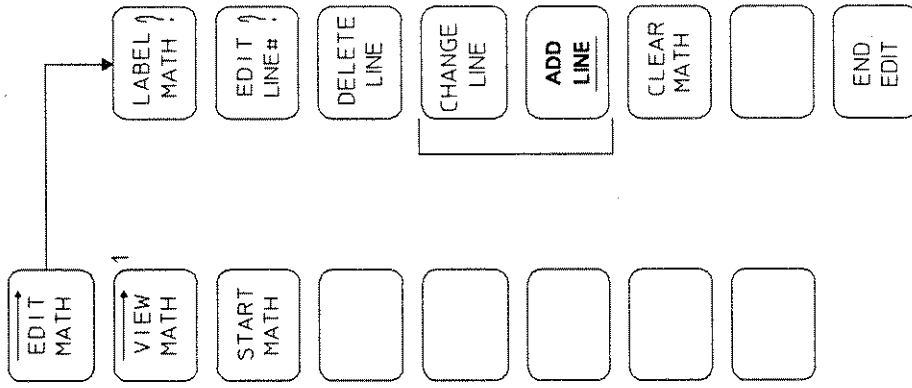

¹This softkey has the same effect as pressing [EDIT MATH] followed by [END EDIT]

AUTO SEQ

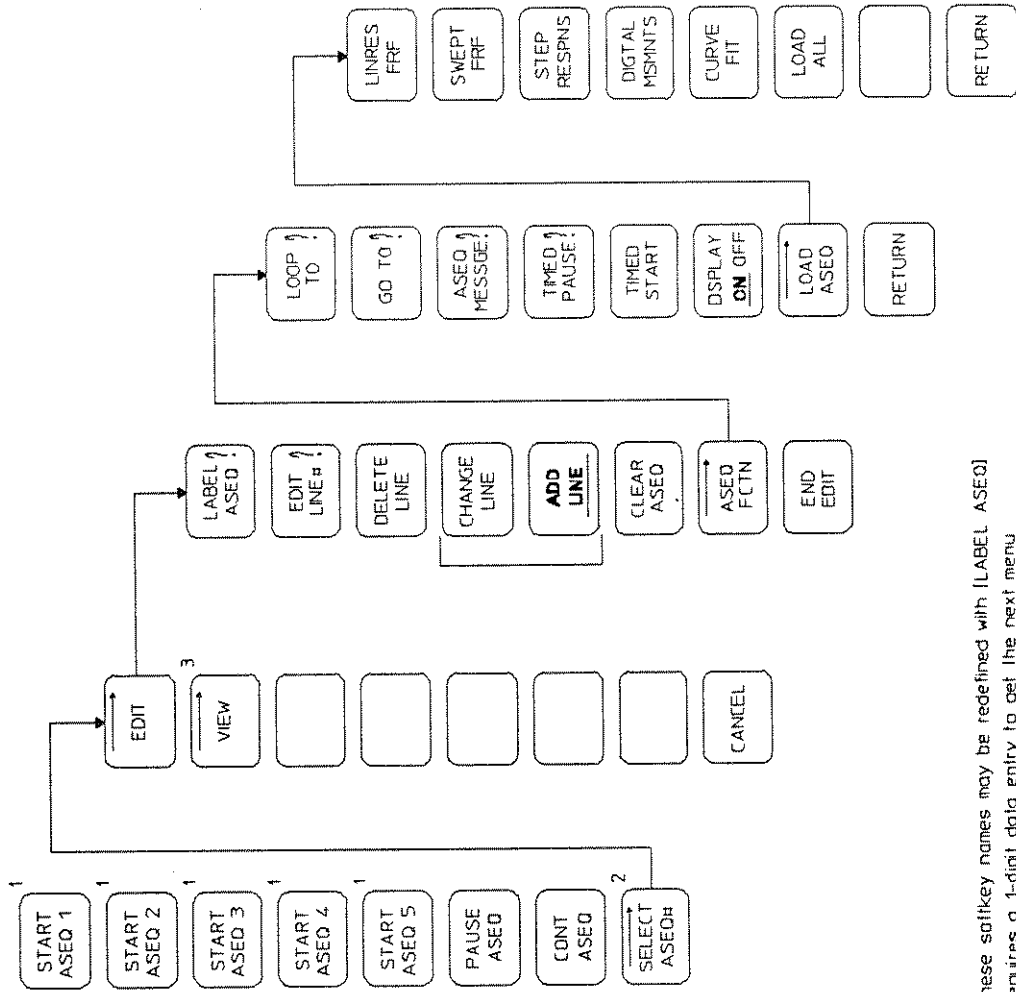

1 These softkey names may be redefined with [LABEL ASEQ]
 2 Requires a 1-digit data entry to get the next menu
 3 This softkey has the same effect as pressing [EDIT] followed by [END EDIT]

AVG

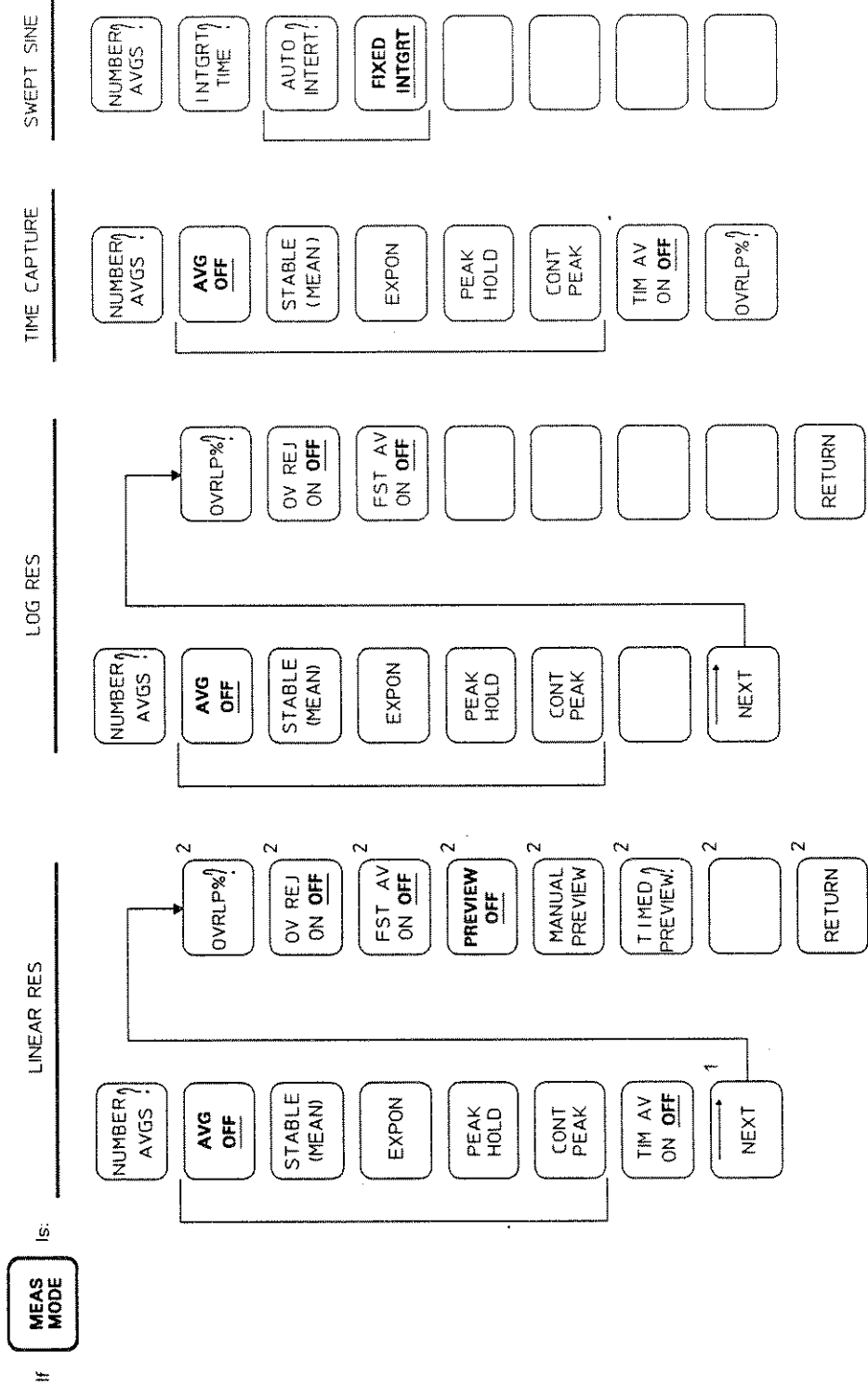

1 Reads [OV REJ ON OFF] if **MEAS MODE** [DEMO ON OFF] is selected
 2 These softkeys are unavailable if **MEAS MODE** [DEMOD ON OFF] is selected

Average Menu Diagram

CAL

AUTO
ON OFF

SINGLE
CAL

COORD

MAG
(dB)

MAG
(dBm)

MAG
(LOG)

MAG
(LIN)

PHASE

REAL

IMAG

NEXT

NYOUST

NICHOL

LOG X

LIN X

RETURN

Calibration Menu Diagram

Coordinates Menu Diagram

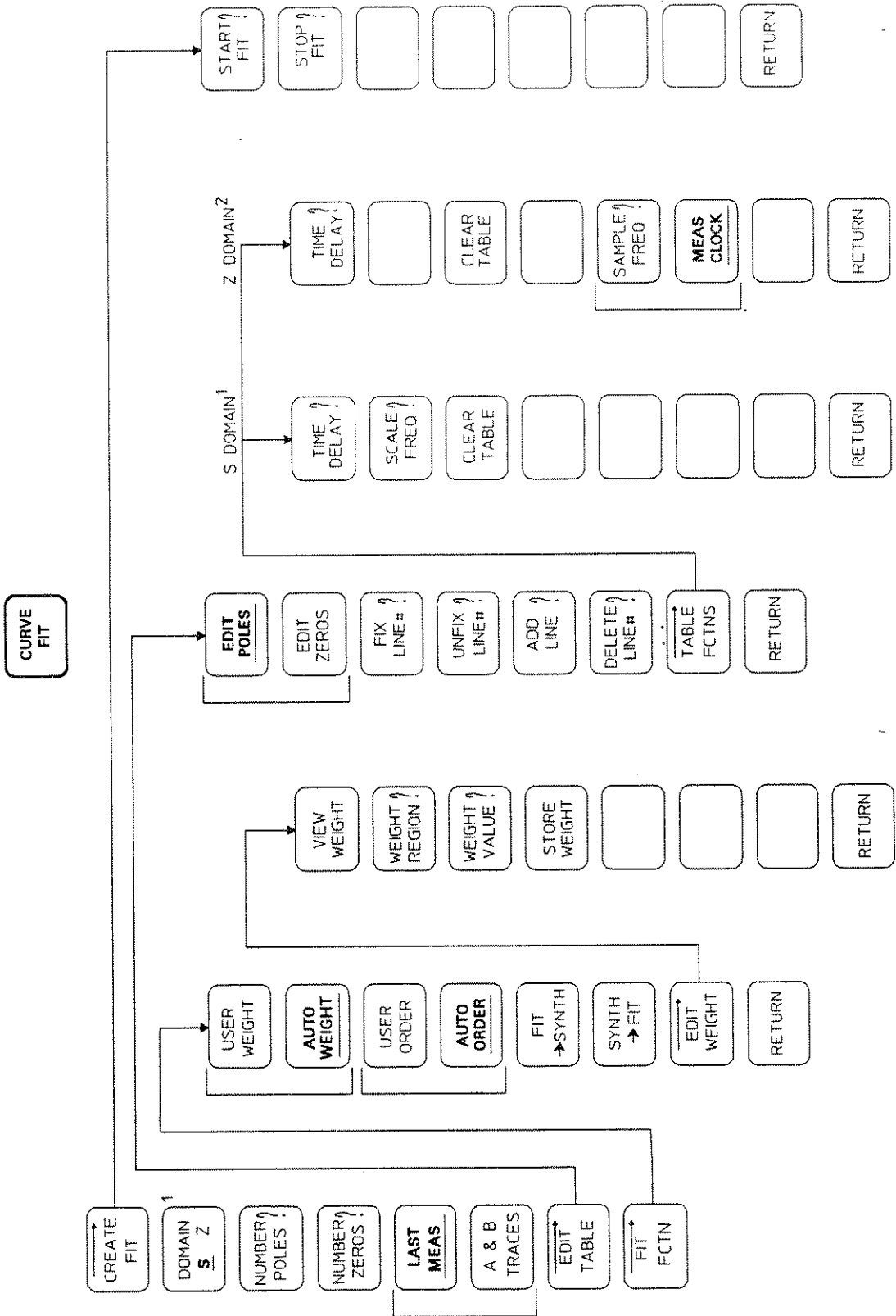

¹ This menu appears when [DOMAIN S Z] is selected.

² This menu appears when [DOMAIN S Z] is selected.

Curve Fit Menu Diagram

DISC

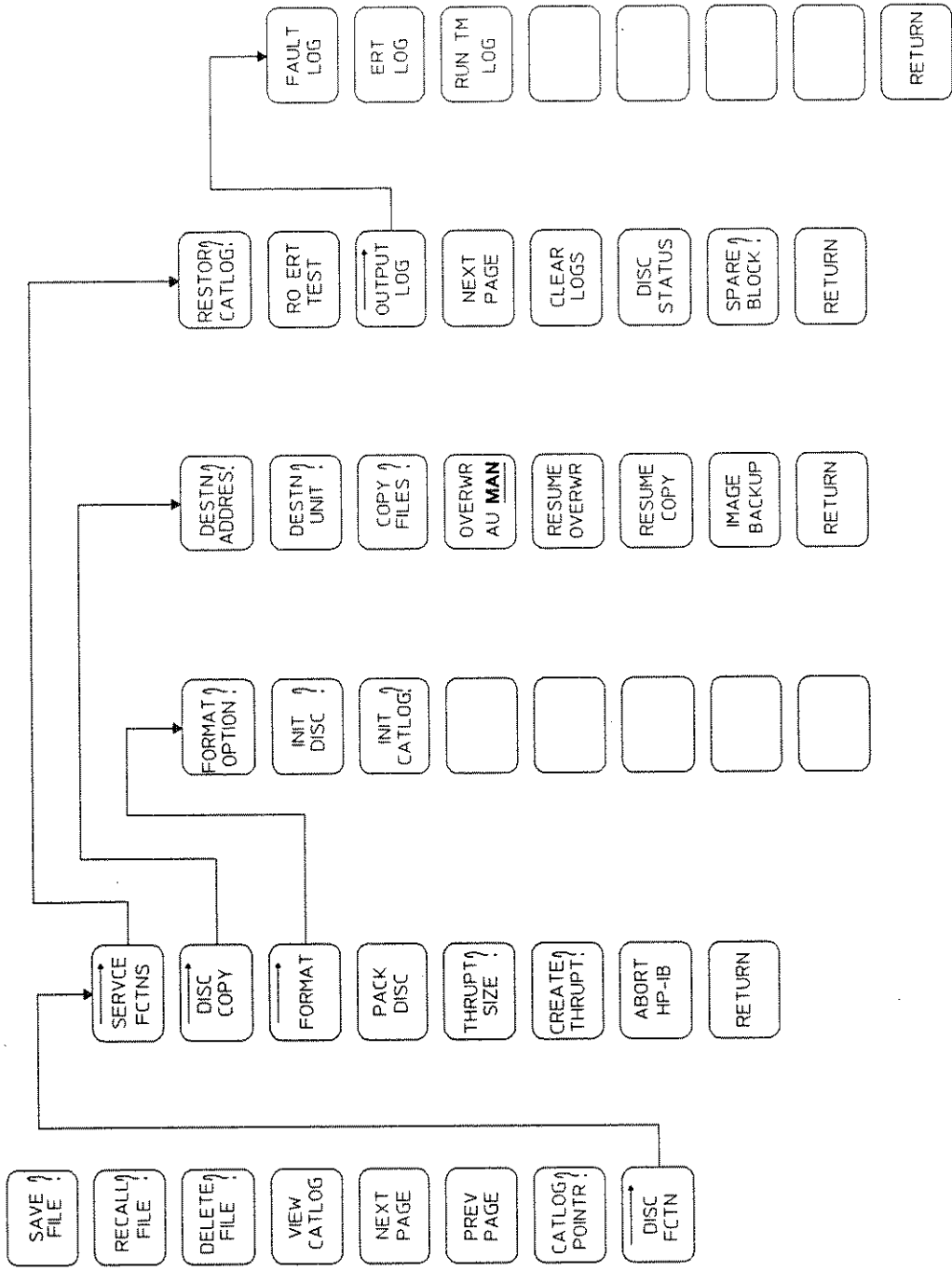

Disc Menu Diagram

ENGR
UNITS

EU VAL
CHAN 1:

VOLTS
CHAN 1

EU LBL
CHAN 1:

EU VAL
CHAN 2:

VOLTS
CHAN 2

EU LBL
CHAN 2:

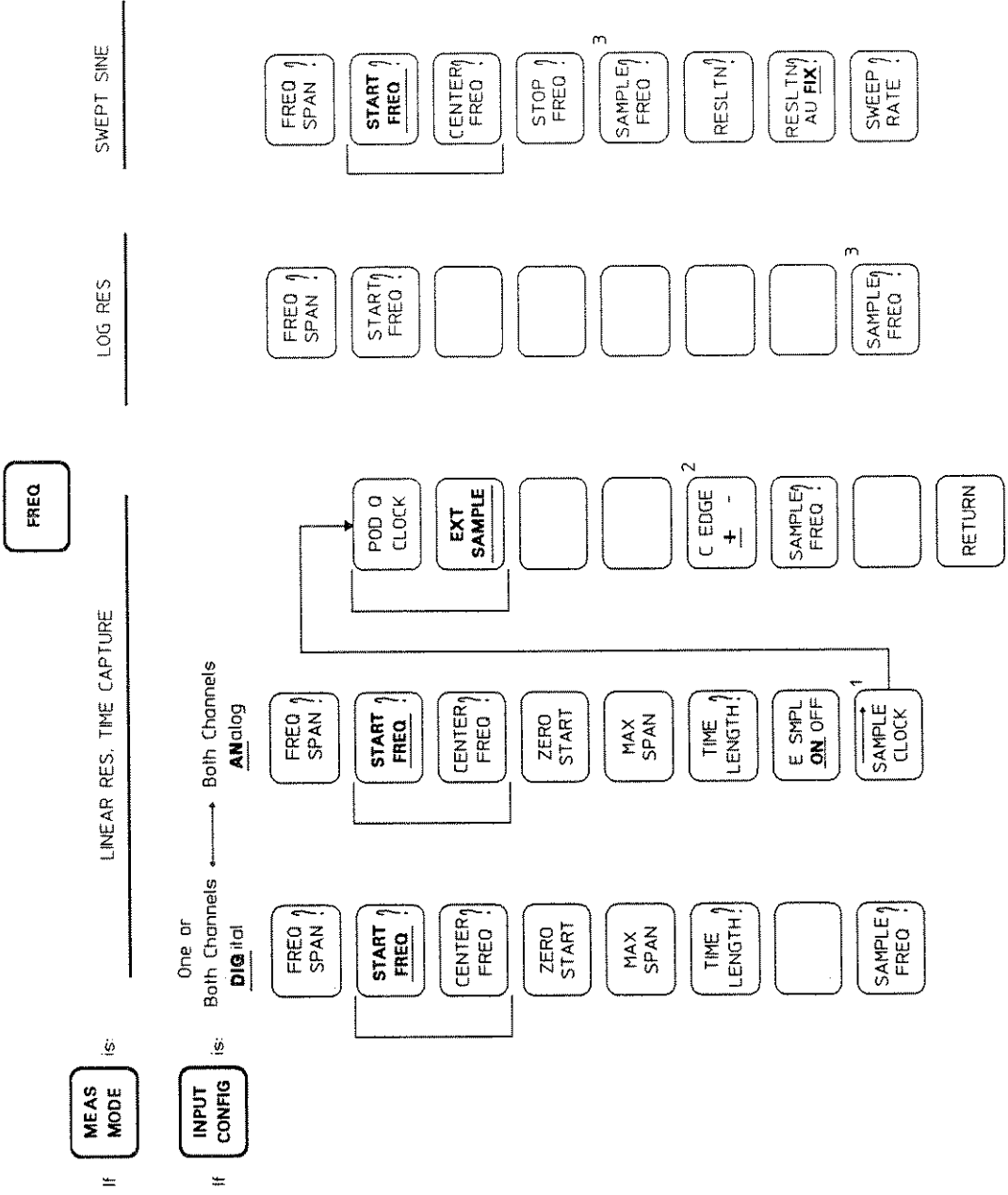

1 Blank if [E SMPL ON OFF] is selected (this is the default)

2 Blank if [EXT SAMPLE] is selected

3 Blank if both channels are ANALog

HP-IB
FCTN

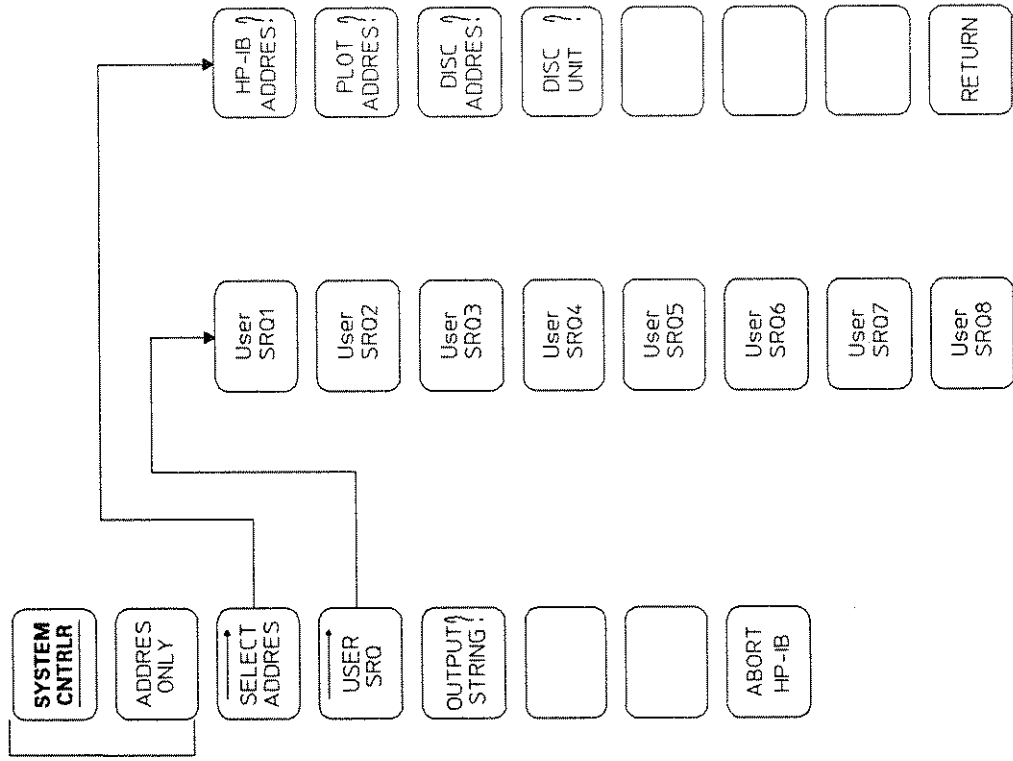

HP-IB Function Menu Diagram

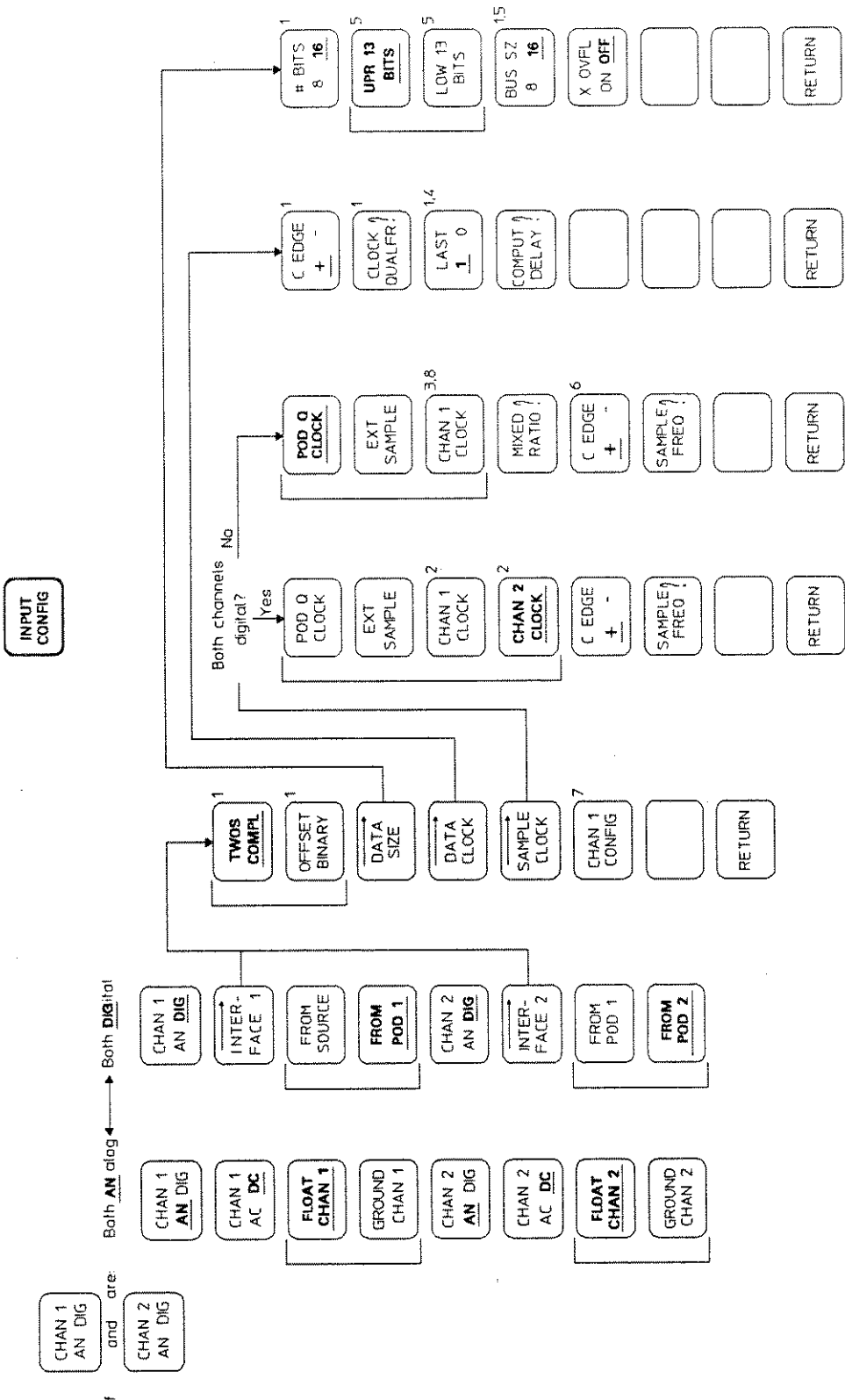

- 1 Blank for [INTERFACE 1] if Chan 1 is [FROM SOURCE]
- 2 If Chan 1 is [FROM SOURCE] then sample clock is [CHAN 2 CLOCK] (no option)
- 3 Reads [CHAN 2 CLOCK] if [CHAN 2 AN DIG] is selected
- 4 Blank except when [#Bits 8 16] and [Bus Sz 8 16] is selected
- 5 Blank if [#Bits 8 16] is selected
- 6 Blank if [EXT SAMPLE], [CHAN 1 CLOCK], or [CHAN 2 CLOCK] is selected
- 7 Reads [CHAN 2 CONFIG] for [INTERFACE 2]
- 8 Blank if chan 1 is [FROM SOURCE] and [CHAN 2 AN DIG] is selected

Input Configuration Menu Diagram

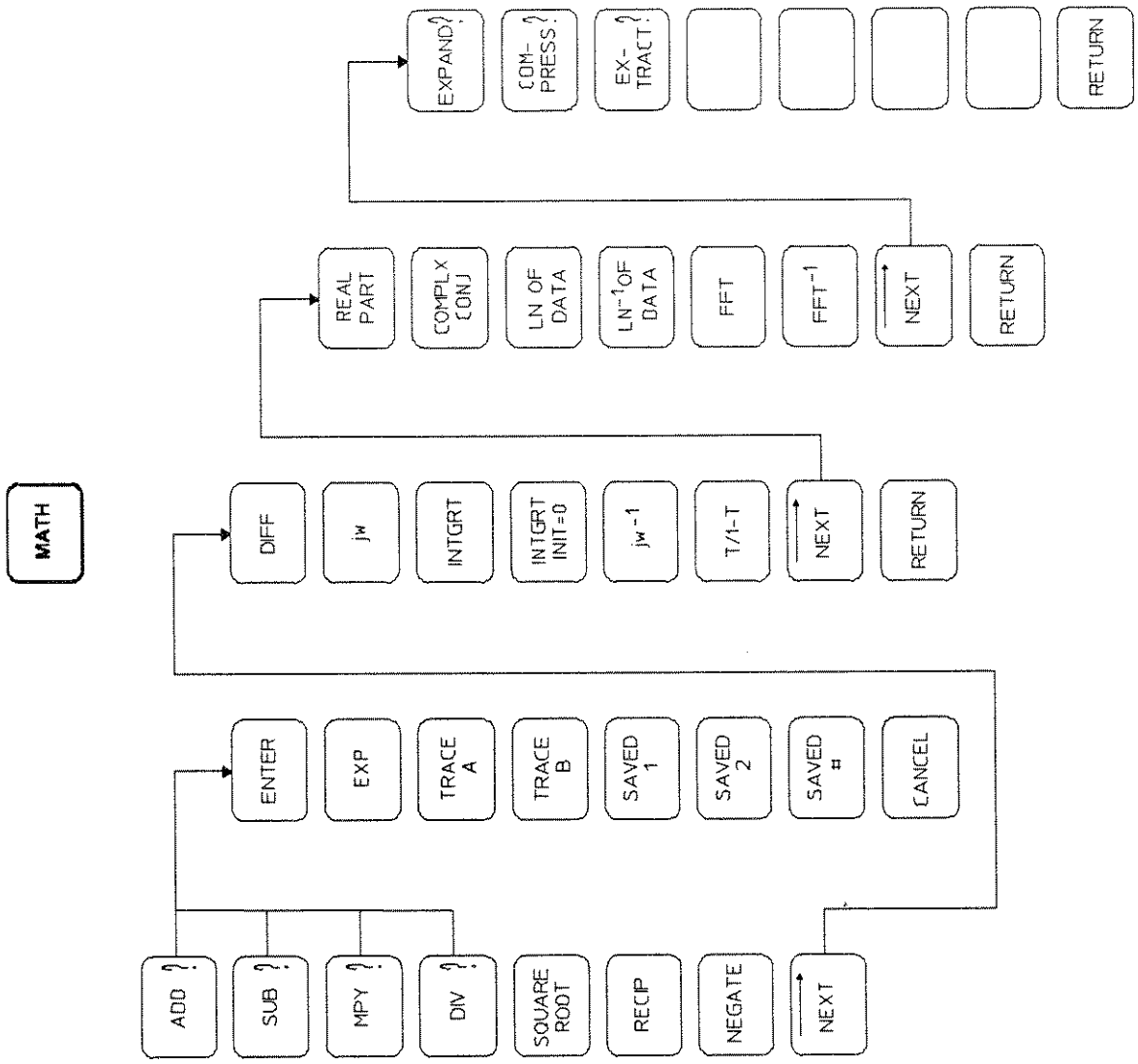

Math Menu Diagram

MEAS DISP

LINEAR RES

If MEAS MODE is

And SELECT MEAS is

And AVG is

FREQ RESP		POWER SPEC		CROSS CORR		AUTO CORR		HIST			
TIM AV OFF		TIM AV ON		Both Channels Active		One Channel Active		Both Channels Active		One Channel Active	
FREQ RESP	COHER	POWER SPEC 1	CROSS CORR	AUTO CORR 1	HIST 1	POWER SPEC 1	POWER SPEC 1	CROSS CORR	AUTO CORR 1	HIST 1	HIST 1
COHER		POWER SPEC 2	AUTO CORR 1	AUTO CORR 2	HIST 2	POWER SPEC 2	POWER SPEC 2	AUTO CORR 1	AUTO CORR 2	HIST 2	HIST 2
POWER SPEC 1	POWER SPEC 1	CROSS SPEC	AUTO CORR 2		PDF 1	CROSS SPEC	CROSS SPEC			PDF 1	PDF 1
POWER SPEC 2	POWER SPEC 2	IMPLS RESP			PDF 2	IMPLS RESP	IMPLS RESP			PDF 2	PDF 2
CROSS SPEC	IMPLS RESP				CDF 1					CDF 1	CDF 1
IMPLS RESP	AUTO MATH				CDF 2					CDF 2	CDF 2
AUTO MATH	FILTRD INPUT				AUTO MATH					AUTO MATH	AUTO MATH
FILTRD INPUT					FILTRD INPUT					FILTRD INPUT	FILTRD INPUT

1 If channel 1 is active, this key selects a measurement for channel 1.
 If channel 2 is active, it selects a measurement for channel 2.
 2 See "Filtered Input Menu Diagram: Both Channels Active" on following pages.
 3 See "Filtered Input Menu Diagram: One Channel Active" on following pages.
 4 The default Auto Math key label is shown. This softkey label is user modifiable.

Measurement Display Menu Diagram

MEAS DISP

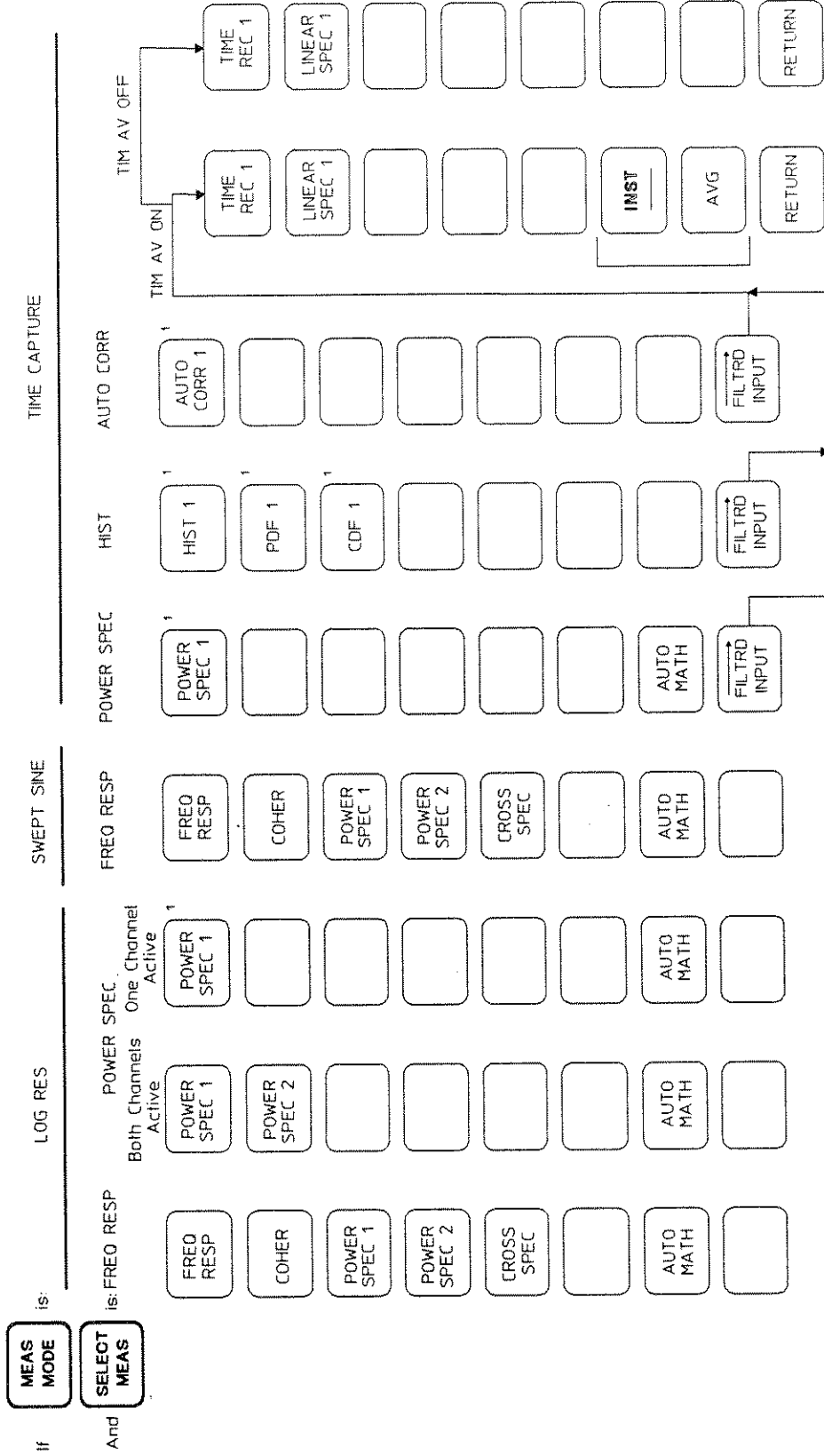

¹ If Channel 1 is active, this key selects a measurement display for Channel 1.
 If Channel 2 is active, it selects a measurement display for Channel 2.

MEAS DISP

FILTRD INPUT

Filtered Input Menu When One Channel is Active
(Continued from Figure 3-6)

When demodulation is OFF¹
and averaging is ON³
and previewing is ON⁴
and WINDOW is FORCE EXPON

When demodulation is ON²
and Channel 1 is AM CHAN 1⁵
and Channel 2 is PM CHAN 2⁵
All other configurations

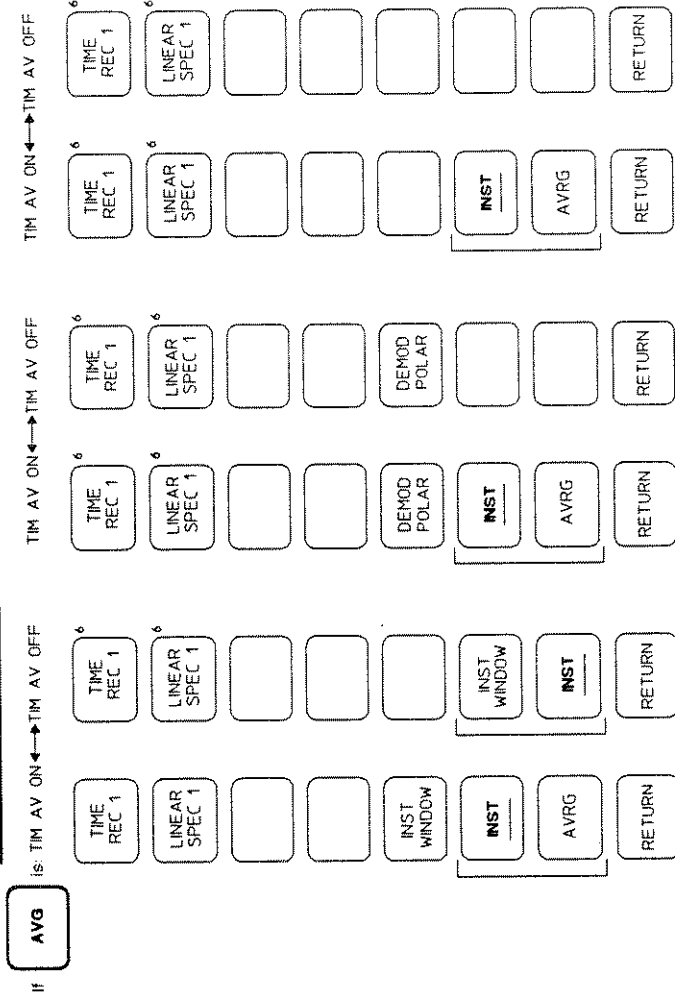

¹ Demodulation is OFF when MEAS MODE [DEMOD ON OFF] is selected.
² Demodulation is ON when MEAS MODE [DEMOD ON OFF] is selected.
³ Averaging is ON when any average type is selected (in other words, when AVG is not [AVG OFF]).
⁴ Previewing is ON when AVG [NEXT] [MANUAL PREVIEW] or [TIMED PREVIEW] is selected.
⁵ Press MEAS MODE [DEMOD SELECT] [DEMOD BOTH] to configure both channels for demodulation.
⁶ If Channel 1 is active, this key selects a measurement for Channel 1. If Channel 2 is active, it selects a measurement for Channel 2.

Filtered Input Menu Diagram: One Channel Active



Filtered Input Menu When Both Channels are Active
(Continued from MEAS DISP Menu Diagram)

When demodulation is OFF¹
AND averaging is ON²
AND previewing is ON⁴
AND WINDOW is FORCE EXPON

When demodulation is ON²
AND Channel 1 is AM CHAN 1⁵
AND Channel 2 is PM CHAN 2⁵ All other configurations

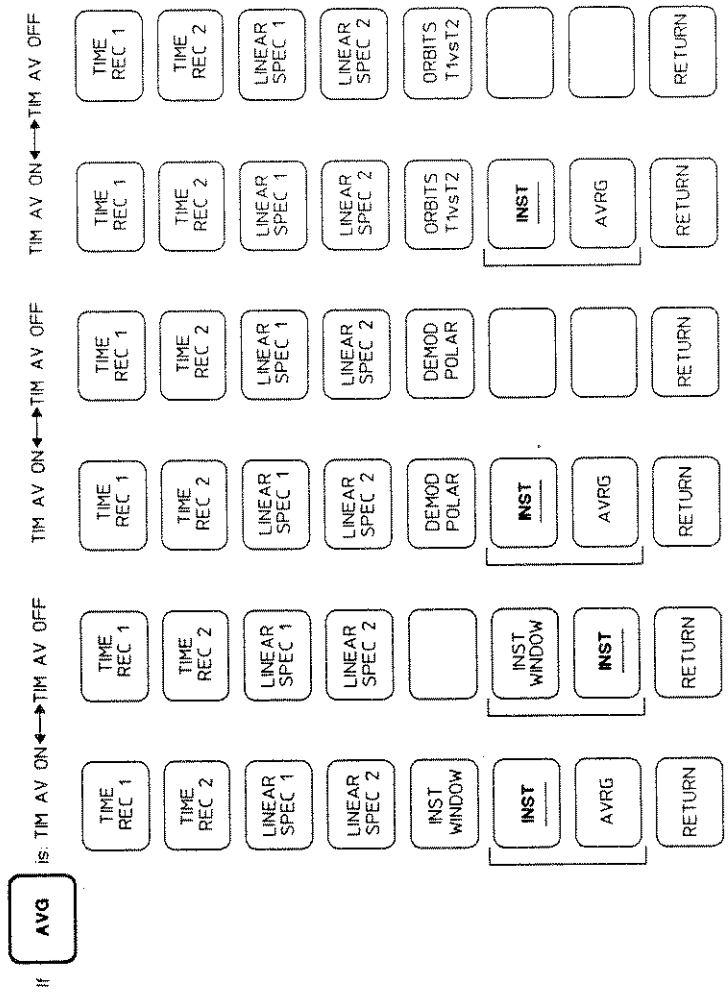

¹ Demodulation is OFF when MEAS MODE [DEMOD ON OFF] is selected.
² Demodulation is ON when MEAS MODE [DEMOD ON OFF] is selected.
³ Averaging is ON when any average type is selected (in other words, when AVG is not [AVG OFF]).
⁴ Previewing is ON when AVG [NEXT] [MANUAL PRVIEW] or [TIMED PRVIEW] is selected.
⁵ Press MEAS MODE [DEMOD SELECT] [DEMOD BOTH] to configure both channels for demodulation

Filtered Input Menu Diagram: Both Channels Active

**MEAS
MODE**

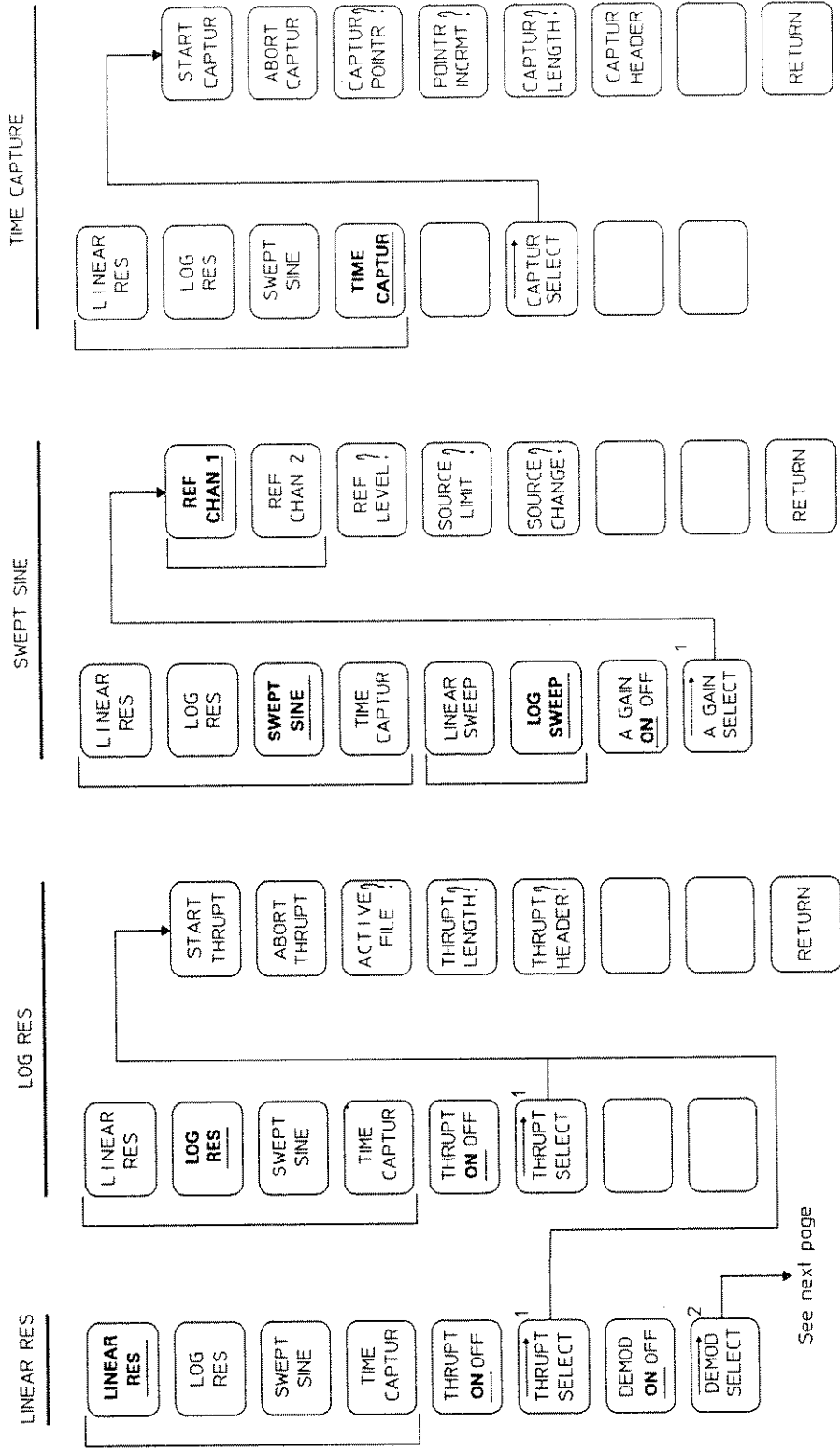

¹ Blank if [THRPT ON OFF] is selected (this is the default)

² Blank if [DEMOD ON OFF] is selected (this is the default)

³ Blank if [A GAIN ON OFF] is selected (this is the default)

MEAS MODE
 DEMOD SELECT

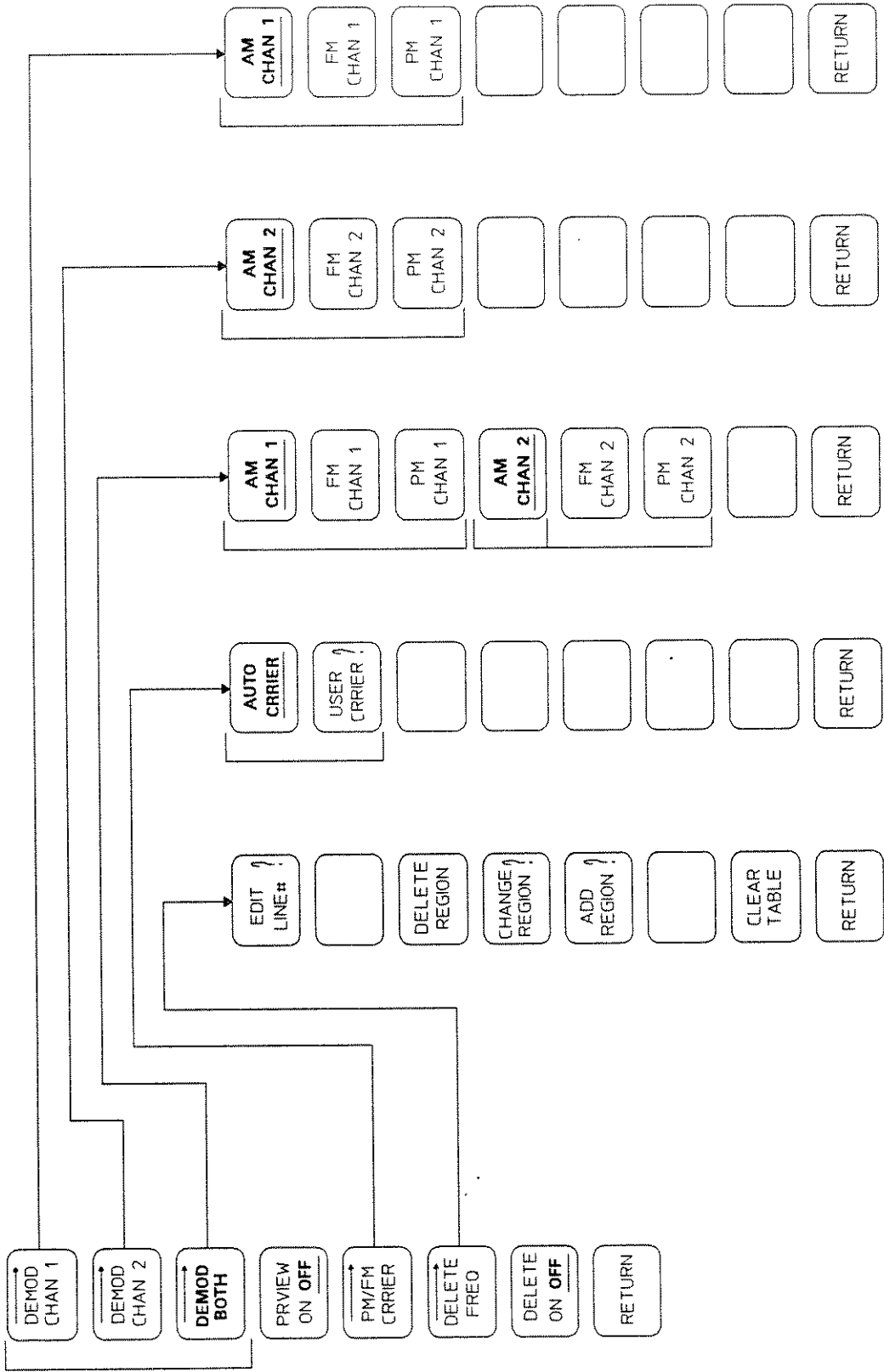

MEAS MODE DEMOD SELECT Menu Diagram

PLOT

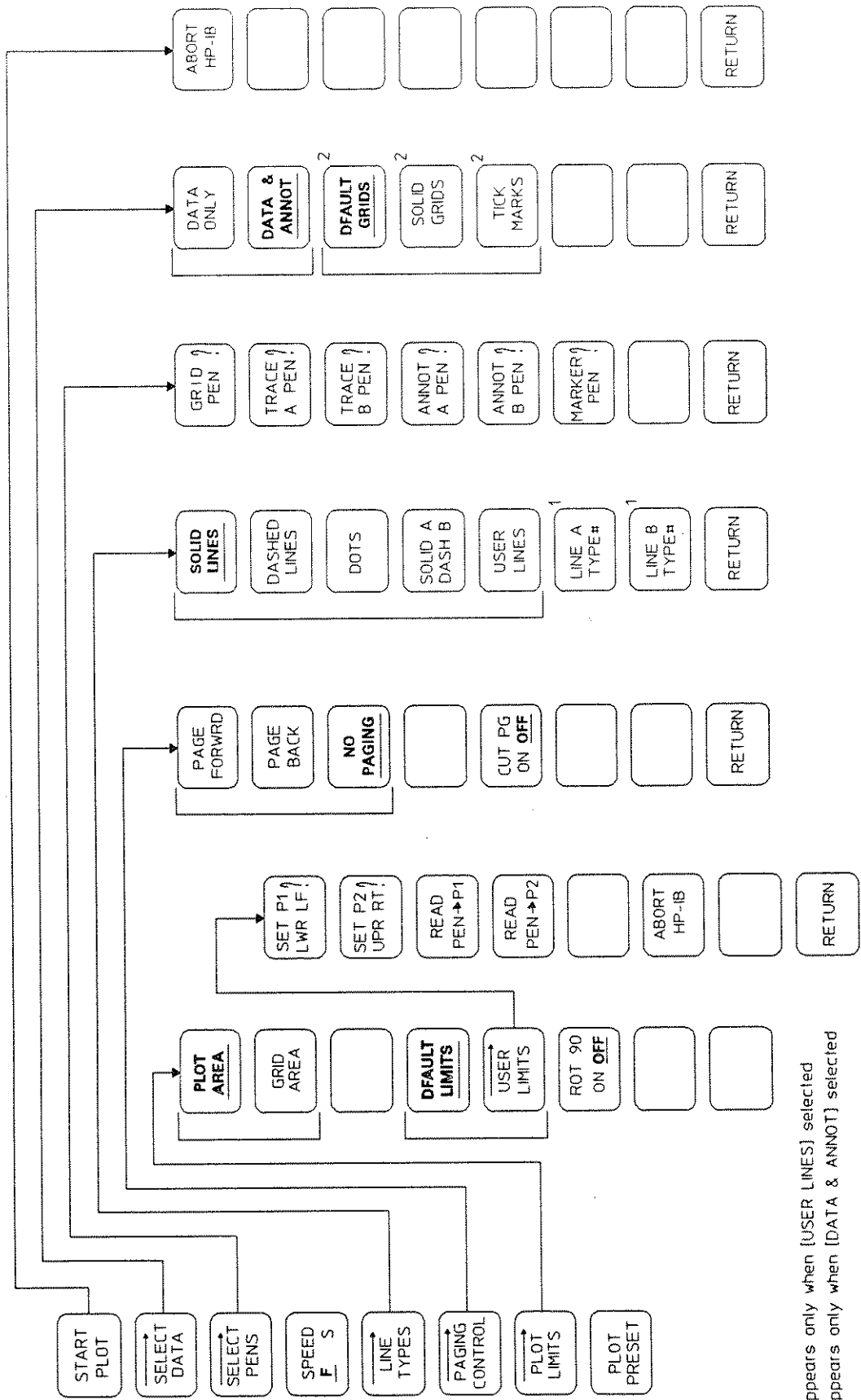

1 Appears only when [USER LINES] selected
 2 Appears only when [DATA & ANNOT] selected

Plot Menu Diagram

PRESET

F RESP
LINRES

F RESP
LOGRES

F RESP
SWEPT

P SPEC
LINRES

TIME
CAPTUR

TIME
THRUPT

RESET

Preset Menu Diagram

RANGE

MEAS MODE is: LINEAR RES. LOG RES. TIME CAPTURE SWEPT SINE

INPUT CONFIG is: Both Channels Analog Both Channels Digital

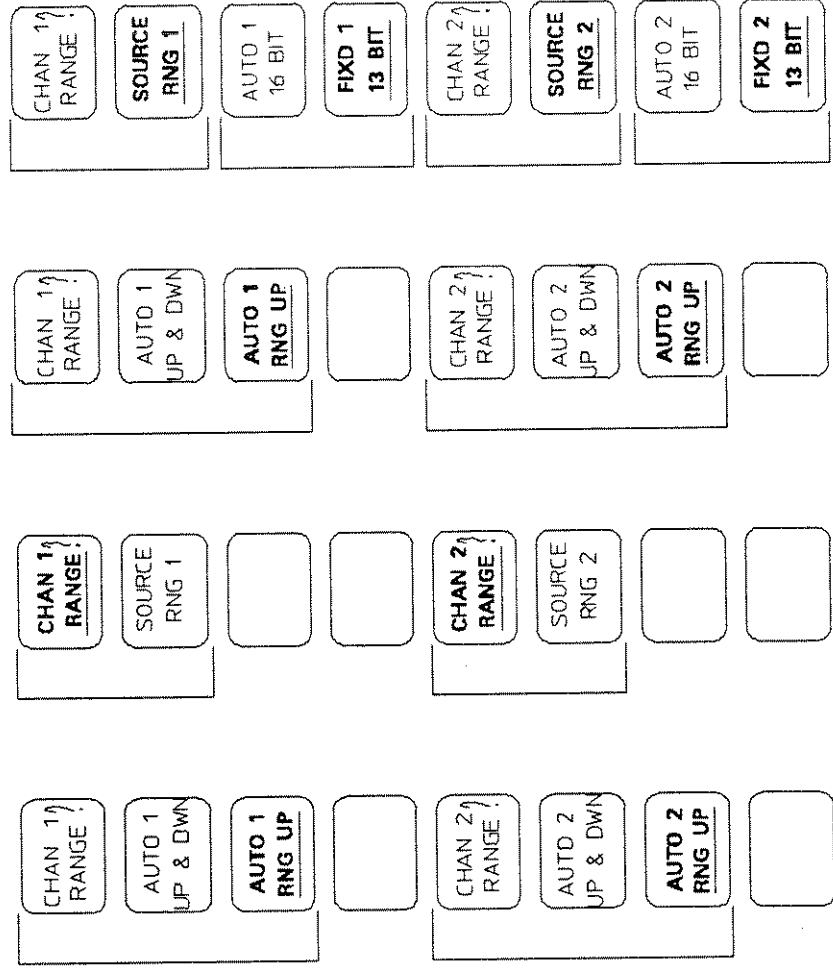

Range Menu Diagram

SAVE
RECALL

RECALL
PWR ON

RECALL
STATE#;

SAVE
STATE#;

RECALL
DATA#;

SAVE
DATA#;

SCALE

X FIXD
SCALE ?

X MRKR
SCALE

X AUTO
SCALE

Y FIXD
SCALE ?

Y MRKR
SCALE

Y AUTO
SCALE

Y DFLT
SCALE

Save Recall Menu Diagram

Scale Menu Diagram

**SELECT
MEAS**

**MEAS
MODE**

if is:

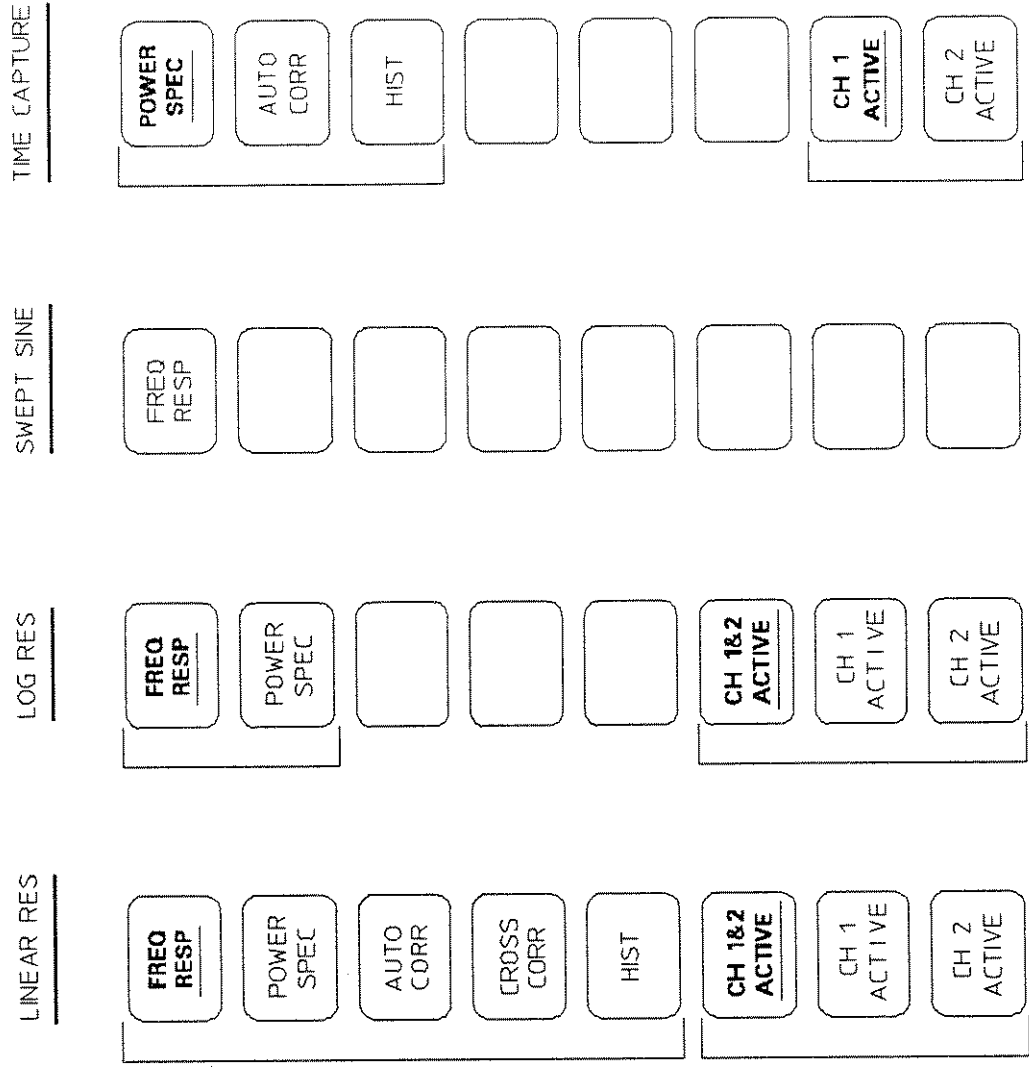

Select Measurement Menu Diagram

SELECT TRIG

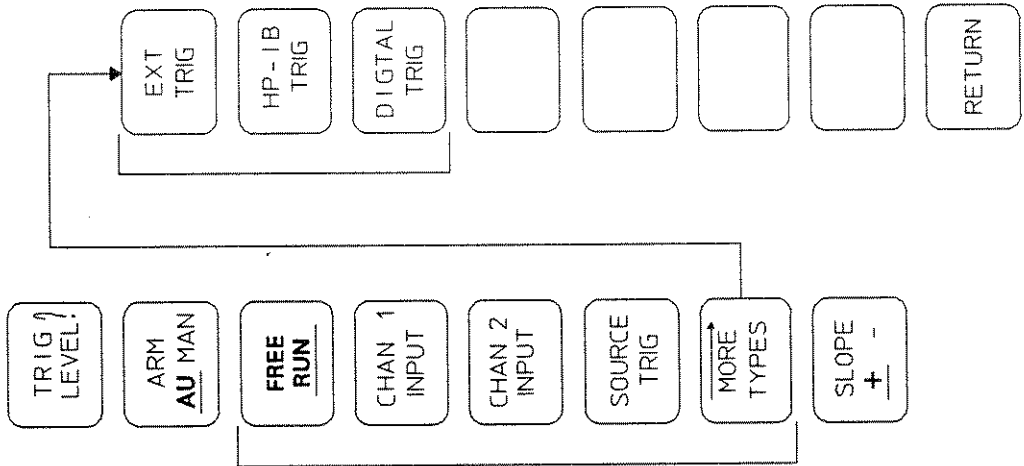

Select Trigger Menu Diagram

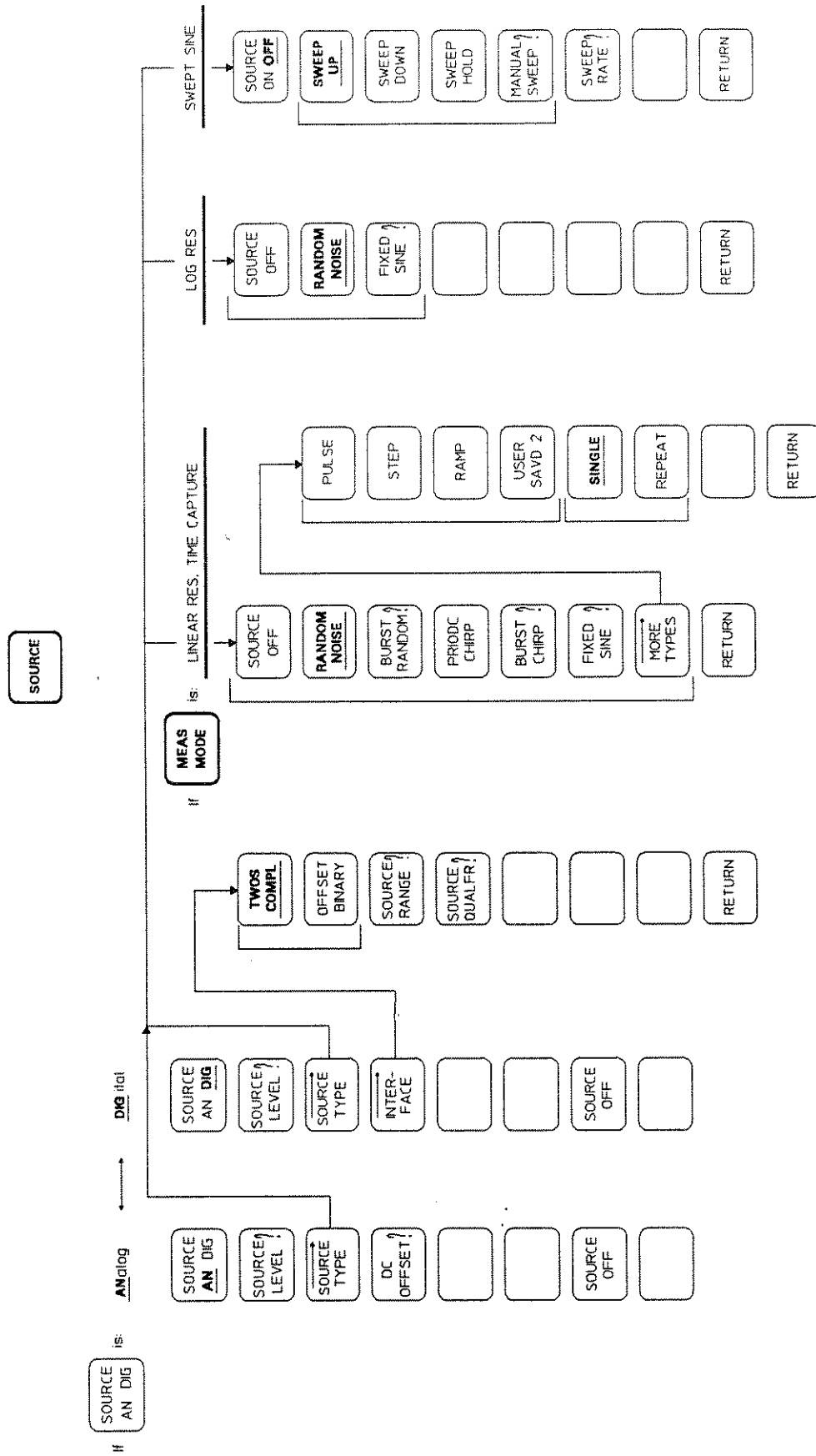

Source Menu Diagram

**SPCL
FCTN**

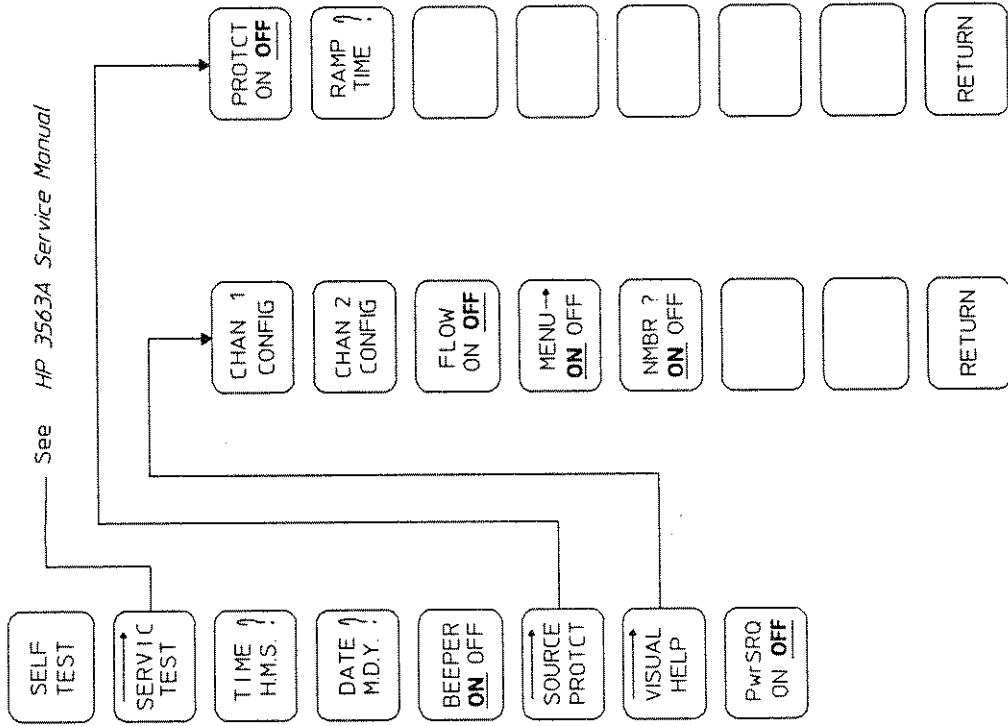

Special Function Menu Diagram

**SPCL
MARKER**

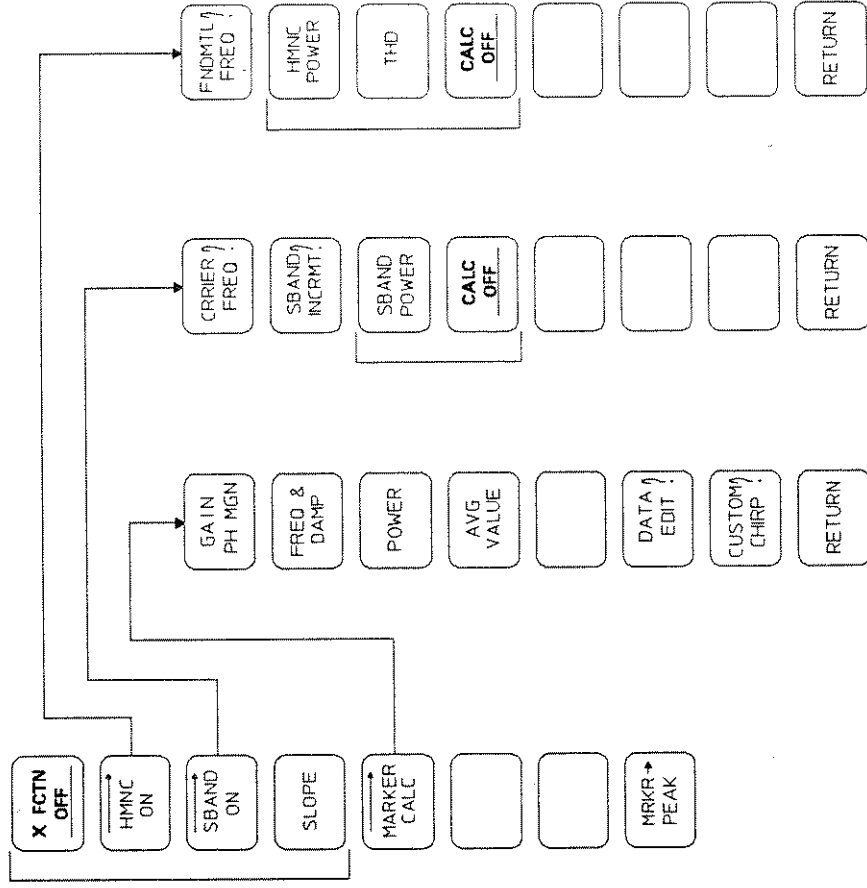

Special Marker Menu Diagram

See HP 3563A Service Manual

SYNTH

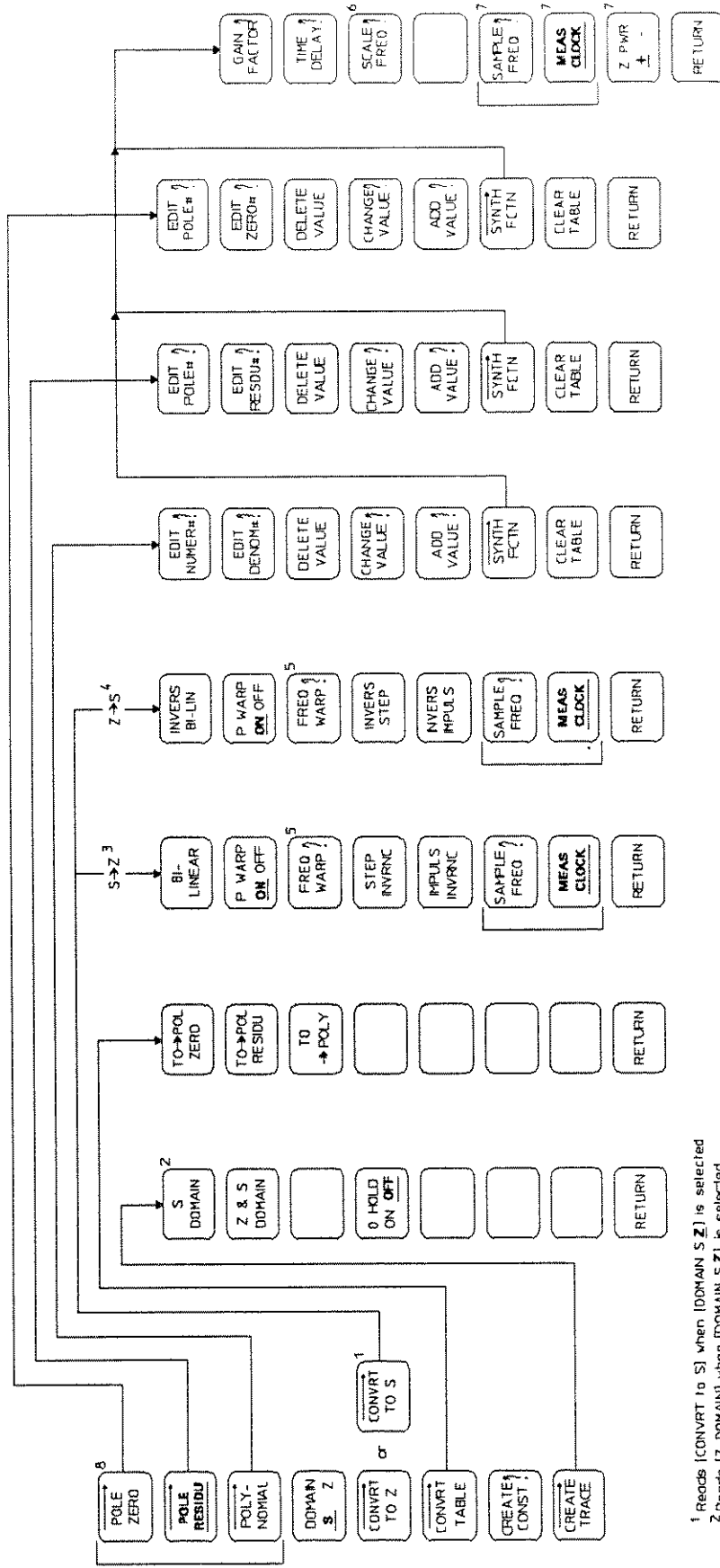

1 Reads [CONVERT TO S] when [DOMAIN S Z] is selected
 2 Reads [Z DOMAIN] when [DOMAIN S Z] is selected
 3 This menu appears when [DOMAIN S Z] is selected
 4 This menu appears when [DOMAIN S Z] is selected
 5 Blank if [P WARP ON OFF] is selected (this is the default)
 6 Blank if [DOMAIN S Z] is selected
 7 Blank if [DOMAIN S Z] is selected
 8 [POLE ZERO] is the default if [DOMAIN S Z] is selected

Synthesis Menu Diagram

TRIG
DELAY

CHAN 1)
DELAY:

CHAN 2)
DELAY:

Trigger Delay Menu Diagram

UNITS

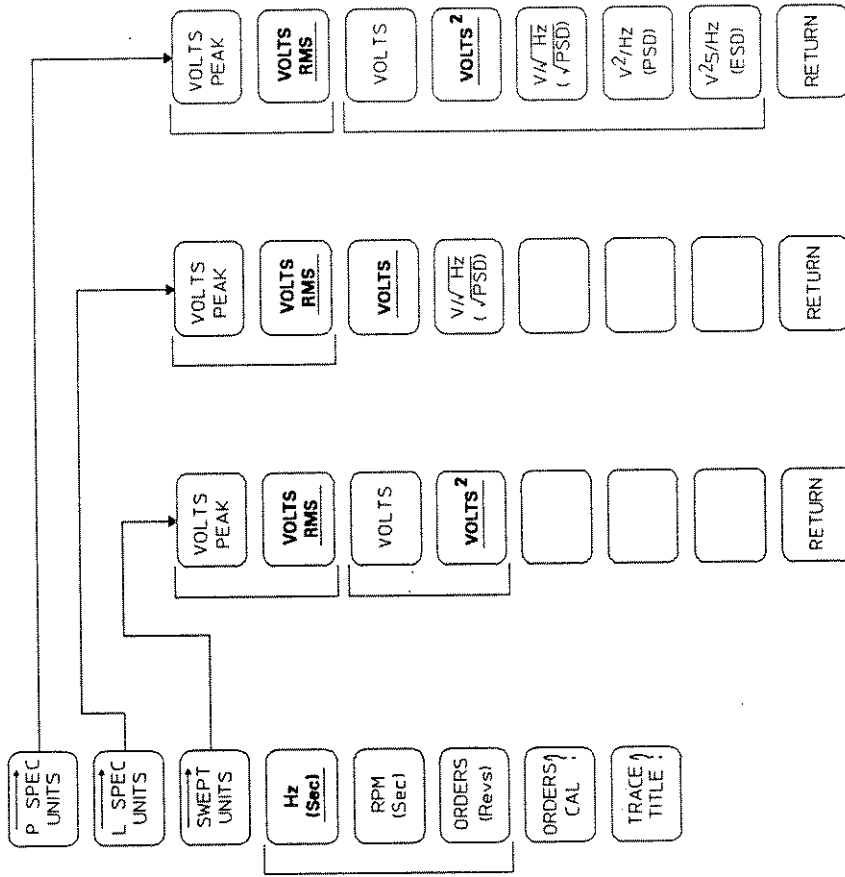

Units Menu Diagram

VIEW INPUT

MEAS MODE

If

LINEAR RES. LOG RES

SWEPT SINE

TIME CAPTURE

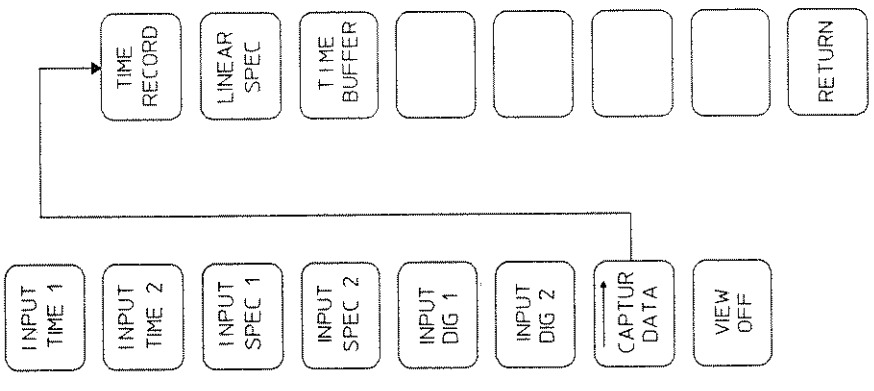
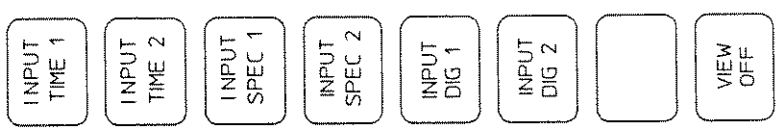
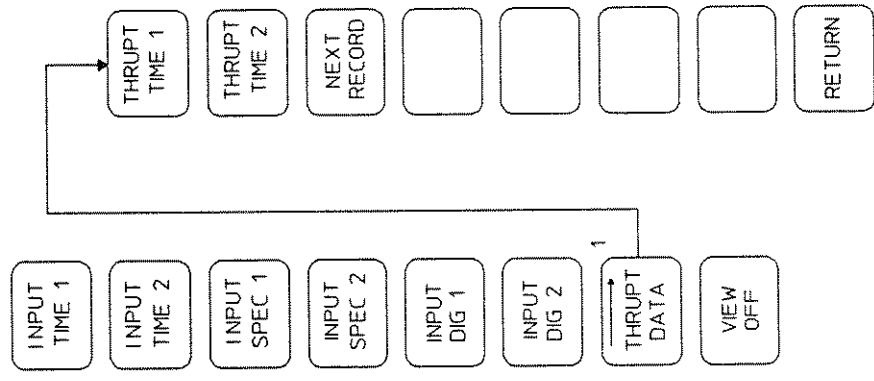

1 Blank if MEAS MODE [THRUPT ON OFF] is selected

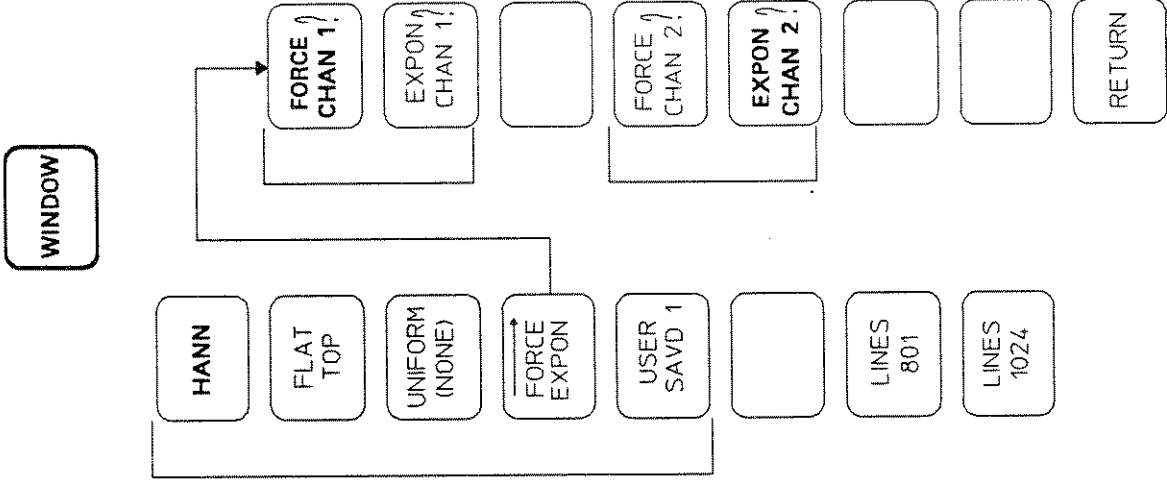

Window Menu Diagram

X

X
VALUE?

X MRKR
SCALE

X AUTO
SCALE

SCROLL
ON OFF

HOLD **X**
CENTER

HOLD **X**
RIGHT

HOLD **X**
LEFT

HOLD **X**
OFF

X Menu Diagram

Y

Y
VALUE?

Y MRKR
SCALE

Y AUTO
SCALE

Y DFLT
SCALE

HOLD **Y**
CENTER

HOLD **Y**
RIGHT

HOLD **Y**
LEFT

HOLD **Y**
OFF

Y Menu Diagram

Index

- ! Attention symbol 1-7
- Instantaneous displays
 - See also view input displays
- RNG 1: digital operation 7-36
- View input displays
 - See also instantaneous displays
- 8-Bit Bus
 - Clocking in 16-bit words 7-13
- A**
- A & B TRACES 16-49
- A (Indicator LED) A-3
- A GAIN ON OFF 5-4, 5-12
- A GAIN SELECT 5-4, 5-12
- A&B (key) 8-3
- ABORT CAPTUR 6-7
- ABORT HP-IB 11-3
 - During disc copy 11-26
 - During throughput 11-13, 11-23
 - In Time throughput 9-7
- ABORT THRUPT 9-12, 9-17
- AC coupling 7-5
- Accessories, digital 13-8
- ACTIVE FILE 9-12, 9-17, 9-22
- Active throughput file 9-17, 9-19
- Active Trace
 - selecting 8-3
 - When saving traces 8-33
- Active trace keys 1-9
- ADD 15-4
- ADD LINE 16-51
- ADD LINE (auto math) 15-20
- ADD LINE (Auto sequences) 10-4
- ADD REGION 3-90
- Addition 15-4
- ADDRES ONLY 11-3
- Addresses, HP-IB 11-3
- Addressing disc drives 11-1
- Advanced analysis 1-12
- Aliasing
 - With external sampling 3-64
- Alpha menu 9-9
 - Entering EU labels 7-46
 - Entering trace titles 8-9
 - Labeling auto sequences 10-11
 - Selecting disc files 11-22 - 11-23
- AM demodulation 3-92
- Amplitude accuracy
 - Log resolution mode 4-21
 - With windows 3-70
- Analog channel
 - autoranging 7-30
 - range 7-29
- Analog inputs
 - block diagram 7-7
 - data paths 7-2
- ANNOT A PEN 11-10
- ANNOT B PEN 11-10
- Anti-aliasing protection
 - With external sampling 3-65
- Antilog 15-14
- Arbitrary source 3-19
 - normalizing 3-22
 - restrictions 3-20
- ARM 7-42
- ARM AU MAN 7-38
- ARM hardkey 1-14
- Arrow keys 1-11
- Artificial Differentiation 15-4
- Artificial integration 15-11
- ASEQ FCTN 10-4
- ASEQ MESSGE 10-5
- AT POINTR 11-21, 11-26
- AUTO 1 16-BIT 7-36
- AUTO 1 RNG UP 7-29
- AUTO 1 UP&DWN 7-29
- AUTO 2 RNG UP 7-30
- AUTO 2 UP&DWN 7-30
- Auto alignment 7-35
- Auto arming 7-42
- Auto arming vs manual arming 7-42
- AUTO CORR
 - Linear res mode 3-32, 3-44
 - Time capture mode 6-17, 6-21
- AUTO CORR 1
 - Linear res mode 3-45, 3-47 - 3-48, 6-21
- AUTO CORR 2
 - Linear res mode 3-45, 3-47 - 3-48, 6-21
- Auto correlation 2-6
- Auto correlation display
 - Linear res mode 3-46, 3-48
- Auto correlation measurement
 - Linear res mode 3-44
 - Time capture mode 6-21
- AUTO CARRIER 3-89, 3-94

Index

Auto gain (swept sine) 5-10
AUTO INTGRT 5-31
Auto math
 introduction to 15-18 - 15-24
 Labels 15-22
 Programming auto math table 15-18
 Starting auto math 15-20
Auto math (key) 15-18
AUTO MATH (softkey)
 Linear res mode 3-35, 3-42, 3-45, 3-47
 Log res mode 4-15, 4-22
 Swept sine mode 5-17
Auto math table 15-20
Auto Math, overview 15-1 - 15-24
AUTO ON OFF 7-43
AUTO ORDER 16-54
Auto resolution (swept sine) 5-29
AUTO SEQ 10-11
 description of 10-2
AUTO SEQ hardkey 1-13
Auto sequence programs
 Autostarts 10-12
 Creating 10-3, 10-6 - 10-8
 Editing existing programs 10-3
 Examples 10-13 - 10-14
 Indefinite processes in 10-1
 Overview 10-1 - 10-14
 Saving to disc 10-12
 Toggle entries in 10-1
 With more than 99 lines 10-10
AUTO WEIGHT 16-54
AUTOMATH hardkey 1-12
Autorange
 analog channel 7-30
 digital channel 7-33
Autoranging
 Swept sine mode 5-34
Average value (marker function) 1-10
Averaging
 in measurement modes 2-17
 overview 2-17
AVG hardkey 1-8
AVG OFF
 Linear res mode 3-75
Axis
 vertical units 2-15

B

B (Indicator LED) A-3
B (key) 8-3
Band-limiting 3-8
Beeper control 1-13
BEEPER ON OFF 12-3

BITS 8 16 7-24
Block Diagrams 12-6
BURST CHIRP
 Linear res mode 3-14
Burst chirp signal
 Linear res mode 3-16
BURST RANDOM
 Linear res mode 3-13
Burst random noise
 Linear res mode 3-17
BUS SZ 8 16 7-24

C

C EDGE
 Linear res mode 3-65
C EDGE + - 7-25, 7-27
Calculating the mixed-ratio value 14-17
CAL 7-43
CAL hardkey 1-8
CALC OFF 8-27
Calendar
 internal 12-3
Calibration 7-43 - 7-44
 at power-up 7-44
 automatic 7-44
 failure 7-43
 inputs 7-43
CAPTUR DATA 6-9
CAPTUR HEADER 6-7, 6-14
CAPTUR LENGTH 6-7
CAPTUR POINTR 6-7, 6-13
CAPTUR SELECT 6-13
Capture channel, selecting 6-11
Capture header 6-14
Capture length 6-11
Captured data
 As input to throughput measurements
 6-28, 9-22
 Measuring 6-15 - 6-27
 Viewing 6-13
Carrier, auto or user 3-94
Catalog, disc 11-21
CATLOG POINTR 11-18, 11-21
CDF 1
 Linear res mode 3-49, 3-52
 Time capture mode 6-22
CDF 2
 Linear res mode 3-49, 3-52
 Time capture mode 6-22
CDF display
 Linear res mode 3-52

- CENTER FREQ
 - Linear res mode 3-57
 - Swept sine mode 5-26
- CH 1 ACTIVE
 - Linear res mode 3-32
 - Log res mode 4-12
 - Time capture mode 6-11, 6-17
 - Time throughput 9-16
- CH 1&2 ACTIVE
 - Linear res mode 3-32
 - Log res mode 4-12
 - Time throughput 9-16
- CH 2 ACTIVE
 - Linear res mode 3-32
 - Log res mode 4-12
 - Time capture mode 6-11, 6-17
 - Time throughput 9-16
- CHAN 1 AN DIG 7-6, 7-21
- Chan 1 Clock 7-16, 7-26
 - when active 7-16
- CHAN 1 CONFIG 7-23, 12-6
- CHAN 1 RANGE: analog operation 7-29
- CHAN 1 RANGE: digital operation 7-35 - 7-36
- CHAN 2 AC DC 7-6
- CHAN 2 AN DIG 7-6, 7-21
- Chan 2 Clock 7-16, 7-27
 - when active 7-16
- CHAN 2 CONFIG 7-23, 12-6
- CHAN 2 RANGE: digital operation 7-35 - 7-36
- CHAN 2 RANGE: analog operation 7-30
- CHAN1 AC DC 7-6
- CHAN1 DELAY 7-42
- CHAN1 INPUT 7-38
- CHAN2 DELAY 7-42
- CHAN2 INPUT 7-38
- CHANGE LINE (auto math) 15-20
- CHANGE LINE (Auto sequence) 10-4
- CHANGE REGION 3-90
- Channel 1 (connector) A-3
- Channel 2 (connector) A-3
- Channel Clock 7-16, 14-4
- Channel clocks
 - when active 7-16
- Channel configuration 12-4
 - diagrams 2-2, 12-6
- Chassis (connector) A-3
- Checklists
 - Demodulation 3-91
 - Linear Res mode 3-2
 - Log res mode 4-2
 - Swept sine mode 5-2
 - Time capture mode 6-2
 - Time throughput 9-2 - 9-3
- Choosing a sample clock 14-6
- CLEAR ASEQ 10-4
- CLEAR LOGS 11-28
- CLEAR MATH 15-20
- CLEAR TABLE 16-53
- CLEAR TABLE (DELETE FREQ table) 3-90
- Clock
 - internal 12-3
- CLOCK QUALFR 7-16, 7-25
- Clock stability 14-18
- Clocks 14-4
- COHER
 - Linear res mode 3-35
 - Log res mode 4-15
 - Swept sine mode 5-17
- Coherence display
 - Linear res mode 3-37
 - Log res mode 4-17
 - Swept sine mode 5-19
- Command strings, HP-IB 11-38
- COMPLEX CONJ 15-5, 15-13
- Complex conjugation 15-13
- COMPRESS 15-5, 15-16
- COMPUT DELAY 7-25
- Computational delay 7-25, 14-6
- Configuration diagrams 2-2
- Configuring the inputs 7-4
- Conjugation 15-13
- Connecting disc drives 11-15
- CONT ASEQ 10-11
- CONT PEAK
 - Linear res mode 3-75
- Control block (key group) 1-13
- Controlling other HP-IB devices 11-38
- Converting V < MV > rms < D > to
V < MV > pk < D > 7-34
- COORD 8-3 - 8-4
- COORD hardkey 1-9
- Coordinates 2-13
 - available 2-13
 - Combining with units 8-4
 - Selecting 8-4 - 8-7
- COPY FILES 11-25 - 11-26
- coupling
 - ac/dc 7-6
- CREATE FIT 16-48

Index

- CREATE THRUPT 9-7 - 9-9, 11-23
 - CROSS CORR (MEAS DISP menu) 3-47
 - CROSS CORR (SELECT MEAS menu) 3-32, 3-47
 - cross Correlation 2-6
 - Cross correlation display 3-48
 - Cross correlation measurement 3-47
 - CROSS SPEC
 - Linear res mode 3-35
 - Log res mode 4-15
 - Swept sine mode 5-17
 - Cross spectrum display
 - Linear res mode 3-39
 - Log res mode 4-19
 - Swept sine mode 5-22
 - CARRIER FREQ (sideband markers) 8-28
 - CURVE FIT 10-8
 - overview 16-2
 - two curve-fitters 16-2
 - 0 Hz start frequency 16-9
 - auto order 16-36
 - auto order, when to use 16-15
 - coherence 16-35
 - creating 16-45
 - data, source of 16-5, 16-40
 - delay 16-38
 - delay, entering 16-43
 - delay, s-domain 16-38
 - delay, z-domain 16-38
 - distortion 16-18
 - domain, selecting 16-40
 - errors 16-16
 - example, FIR filters 16-38
 - example, s domain 16-10
 - fit region, s-domain 16-20
 - fit region, z-domain 16-26
 - formula, s-domain 16-2
 - formula, z-domain 16-2
 - frequency, sample 16-41
 - frequency, scaling 16-41
 - key descriptions 16-47
 - LINES 1024 16-6
 - LINES 801 16-6
 - measurement span 16-19
 - measurements, analog 16-33
 - measurements, mixed 16-34
 - menu diagram 16-47
 - noise and errors 16-18
 - obtaining good results 16-16
 - operating mode, auto order 16-3
 - operating mode, user order 16-3
 - operating modes 16-3
 - operation, auto order 16-7
 - operation, user order 16-8
 - order reduction 16-8
 - order, selecting 16-41
 - order, specifying 16-5
 - overflows, digital 16-18
 - poles, adding 16-43
 - poles, fixed 16-39
 - poles, unstable 16-9
 - quantization error 16-18
 - results, where placed 16-9
 - sample frequency 16-6
 - sample frequency, curve-fit 16-26
 - sample frequency, measurement 16-26
 - scaling frequency 16-6
 - setup procedures 16-4, 16-40
 - softkeys 16-47
 - start freq of 0 Hz 16-9
 - starting 16-7
 - stimuli, broadband 16-16
 - stimuli, fixed sine 16-17
 - stimuli, periodic chirp 16-16
 - stimuli, random noise 16-16
 - stimuli, swept sine 16-17
 - systems with distortion 16-16
 - systems with nonlinearities 16-16
 - table, editing 16-46
 - table, viewing 16-46
 - tables 16-2
 - user order, when to use 16-15
 - weighting function 16-36 - 16-37
 - weighting function, entering 16-43
 - z-domain, analog responses 16-33
 - zeros, adding 16-43
 - zeros, fixed 16-39
 - CURVE FIT hardkey 1-12
 - Curve fit region 16-20
 - CUSTOM CHIRP 8-31
 - CUT PG ON OFF 11-12
- ## D
- DASHED LINES 11-11
 - Data
 - Editing (marker function) 1-10
 - Storage registers 1 through 5 1-13
 - DATA & ANNOT 11-9
 - Data clock 7-23, 14-4
 - menu 7-23, 7-25
 - setting up 7-15
 - Data clock menu 7-25
 - DATA EDIT 8-30
 - Data format 7-23
 - examples 7-14
 - selecting 7-14
 - DATA ONLY (plotting) 11-9

- Data paths 7-2
- Data size 7-23
 - menu 7-24
 - selecting 7-13
- Data size menu 7-24
- Data truncation 14-8
- DATE M, D, Y 12-3
- Date settings 1-13
- DC coupling 7-6
- DC OFFSET
 - Linear res mode 3-10
- Defining the trace 8-3
- Delay, partial-sample 14-6
- DELETE FILE 11-18, 11-21 - 11-22
- DELETE FREQ 3-89, 3-94
- Delete frequency table 3-94
- DELETE LINE # 16-51
- DELETE LINE (auto math) 15-20
- DELETE LINE (Auto sequence) 10-4
- DELETE ON OFF 3-89, 3-94
- DELETE REGION 3-90
- Delta markers 1-10
- DEMOM BOTH 3-89, 3-91
- DEMOM CHAN 1 3-89, 3-91
- DEMOM CHAN 2 3-89, 3-91
- DEMOM ON OFF 3-91
- DEMOM POLAR 3-91, 3-95
- DEMOM POLAR display
 - Scaling 8-15
 - Selecting 3-91, 3-95
 - With COORD menu 8-4
- Demod previewing 3-95
- DEMOM SELECT 3-91
- Demodulated measurements
 - available filtered-input displays 2-11
- Demodulation
 - Activating 3-91
 - Overview 3-87 - 3-96
 - Setup procedures 3-91
- Demodulation types, selecting 3-92
- DESTN ADDRES 11-25
- DESTN UNIT 11-25
- DFAULT GRIDS 11-9
- DFAULT LIMITS 11-12
- Diagrams, menu
 - definition 1-5
- DIFF 15-4, 15-9
- Differentiation 15-9
- Digital
 - Over range message 13-15
- Digital accessories 13-8
- Digital cable length 13-5
- Digital inputs
 - range 7-34
 - # of bits 7-24
 - 16-bit performance 7-36
 - auto alignment 7-35
 - bits used 7-24
 - block diagram 7-7
 - bus size 7-24
 - computational delay 7-25
 - configuring 7-7
 - data clock 7-15
 - Data clock menu 7-25
 - data format 7-14
 - data from source 7-21
 - data paths 7-2
 - data size 7-13
 - Data size menu 7-24
 - Interface menu 7-23
 - overflow 7-33
 - overflows 7-33
 - qualifiers 7-15
 - range 7-33
 - Sample clock menu 7-26
 - selecting data paths 7-9
 - trigger 7-39
- Digital range 14-8
- DIGITAL TRIG 7-39
- Digital trigger 7-39
- DIGITAL MSMNTS 10-8
- DISC 11-17
- DISC ADDRES 11-3, 11-16
- DISC COPY 11-23, 11-25 - 11-26
- Disc drives
 - Addressing 11-16
 - Connecting 11-15
- Disc errors
 - Testing for 11-30
- DISC FCTN
 - Use in throughput 9-7 - 9-8, 11-18, 11-23
- DISC hardkey 1-14
- Disc memory
 - Connecting and addressing 11-15
 - Copy files 11-25 - 11-27
 - Disc functions 11-23
 - Introduction 11-14 - 11-16
 - Saving & recalling displays 11-17 - 11-22
 - Service functions 11-28 - 11-37
 - Using the disc catalog 11-21
- Disc service functions 11-28
- Disc space 11-19
- DISC STSTUS 11-28 - 11-29
- DISC UNIT 11-3, 11-16

Index

Display

- Block (key group) 1-9
 - Coordinates 8-4 - 8-7
 - coordinates and units 2-13
 - Description 8-2
 - Format keys 1-9
 - Formatting 8-3
 - frequency lines 3-67
 - Saving and recalling 8-32 - 8-34
 - Scaling 8-13 - 8-15
 - Selecting display data 8-16 - 8-17
 - Units 8-8
- Display coordinates
available 2-13
- Display Format keys 8-3
- DISPLAY ON OFF (Auto sequence) 10-5
- Display Outputs X,Y,Z (connectors) A-6
- Display units
available 2-14
- Displays
available 2-8
- filtered-input 2-8
 - how derived 2-6
 - instantaneous 2-8
 - measurement displays 2-8
 - measurement modes 2-8
 - overview 2-8
 - view input 2-8
- Displays, instantaneous
linear res mode 3-4 - 3-7
- Displays, selecting
Linear resolution mode 3-33
- Log resolution mode 4-13
 - Swept sine mode 5-15
 - Time capture mode 6-17
- Distortion, quantization 14-8
- DIV 15-4
- Division 15-4
- DOMAINS Z 16-48
- DOTS 11-11
- E**
- E SMPL ON OFF
Linear res mode 3-57
- EDIT 10-3
- EDIT LINE# (auto math) 15-20
 - EDIT LINE# (Auto sequences) 10-4
 - EDIT LINE# (DELETE FREQ table) 3-90
 - EDIT MATH 15-20
 - EDIT POLES 16-50
 - EDIT TABLE 16-49
 - EDIT WEIGHT 16-55
 - EDIT ZEROS 16-50

- ENABLED (Indicator LED) A-3
- END EDIT (auto math) 15-20
- END EDIT (Auto sequences) 10-4
- Engineering units 7-45 - 7-46
 - labels 7-46
- ENGR UNITS 7-45
- ENGR UNITS hardkey 1-8
- Entering trace titles 8-12
- Entry block (key group) 1-11
- Error messages
 - Introduction to B-1
- Error rate test (ERT)
 - Disc 11-30 - 11-31
 - Tapes 11-34
- ERT LOG 11-28
- EU Labels 7-46
 - entering 7-46
- EU LBL CHAN1 7-45 - 7-46
- EU LBL CHAN2 7-45 - 7-46
- EU VAL CHAN1 7-45
- EU VAL CHAN2 7-45
- EUs 7-45
- EXPAND 15-5, 15-16
- EXPON
 - Linear res mode 3-75
- EXPON CHAN 1
 - Linear res mode 3-68
- EXPON CHAN 2
 - Linear res mode 3-68
- Exponential averaging
 - Linear res mode 3-77
- Exponential window
 - Combined with force window 3-72
 - Linear res mode 3-68, 3-72
 - Viewing windowed data 3-73
- EXT SAMPLE 7-26
 - Linear res mode 3-65
- EXT SAMPLE IN (connector) A-6
- EXT TRIG (triggering) 7-39
- EXT TRIGGER (connector) A-3
- EXT TRIGGER (Indicator LED) A-3
- External overflow 14-8
- External overflow rejection (softkey) 13-15
- External sampling
 - linear res mode 3-60
 - both channels analog 3-64
 - definition of 3-64
 - Linear res mode 3-64
 - log res mode 4-27
- External trigger 13-15
- EXTRACT 15-5, 15-17

F

- F RESP LINRES 12-9
- F RESP LOGRES 12-9
- F RESP SWEPT 12-10
- Fast averaging
 - Linear res mode 3-80
- FAULT LOG (disc service only) 11-28, 11-35
- FFT (math function) 15-5, 15-15
- FFT-1 (inverse FFT) 15-5, 15-15
- Filtered input displays
 - Linear res mode 3-82 - 3-86
 - Time capture 6-19
- Filtered-input displays 2-11
- FILTRD INPUT
 - Linear res mode 3-35, 3-42, 3-45, 3-47, 3-49, 3-85, 6-20 - 6-21
 - Time capture mode 6-22
- FIT - SYNTH 16-55
- FIT FCTN 16-49
- FIX LIN # 16-50
- FIXD 1 13-BIT 7-36
- Fixed integration (swept sine mode) 5-32
- FIXED INTGRT 5-31
- Fixed sampling
 - Linear res mode 3-64
- FIXED SINE
 - Linear res mode 3-14
- Fixed sine source output
 - Linear res mode 3-14, 3-17
- FLAT TOP
 - Linear res mode 3-67
- Flat top window
 - Linear res mode 3-67, 3-70
- FLOAT CHAN 1 7-6
- FLOAT CHAN 2 7-6
- Floating the inputs 1-7
- Flow Diagrams 12-6
- FLOW ON OFF 12-6
- FM demodulation 3-92 - 3-93
- FNDMTL FREQ 8-27
- FORCE CHAN 1
 - Linear res mode 3-68, 3-71
- FORCE CHAN 2
 - Linear res mode 3-68, 3-71
- FORCE EXPON
 - Linear res mode 3-67
- Force window
 - Combined with exponential window 3-72
 - Linear res mode 3-68, 3-71
 - Viewing windowed data 3-73
- FORMAT 11-23 - 11-24
- FORMAT OPTION 11-24
- Formatting discs 11-24
- FREE RUN 7-38
- FREQ
 - Linear res mode 3-56
 - Log res mode 4-25
 - Swept sine mode 5-24
- FREQ & DAMP 8-29
- FREQ hardkey 1-8
- FREQ RESP (MEAS DISP menu)
 - Linear res mode 3-35
 - Linear resolution mode 3-35
 - Log res mode 4-12, 4-15
 - Swept sine mode 5-17
- FREQ RESP (SELECT MEAS menu)
 - Linear res mode 3-32
 - Log res mode 4-12
- FREQ SPAN
 - Linear res mode 3-57
 - Log res mode 4-26
 - Swept sine mode 5-26
- Frequency and damping (marker function) 1-10
- Frequency lines
 - 1024 3-67, 6-23
 - 801 3-67, 6-23
- Frequency response 2-6
- Frequency response display
 - linear res mode 3-36
 - Log res mode 4-16
 - Swept sine mode 5-18
- Frequency response measurement
 - Linear res mode 3-35
 - Log res mode 4-15
 - Swept sine mode 5-17
- Frequency span
 - valid, log res mode 4-27
 - valid, swept sine mode 5-27
- Frequency spans
 - Linear res mode 3-56
 - Log res mode 4-24 - 4-28
 - Relation to time record length 3-63
 - Swept sine mode 5-24 - 5-29
 - Time capture 6-11, 6-24, 9-16
 - valid, linear res mode 3-59
- FROM POD 1 7-21 - 7-22
- FROM POD 2 7-22
- FROM SOURCE 7-21
- FRONT BACK 8-3

Index

Front-panel key groups 1-7
Control block 1-13
Display block 1-9
Entry block 1-11
Help block 1-15
HP-IB block 1-14
Markers block 1-10
Measurement block 1-8
Operators block 1-12
Status block 1-14

FST AV ON OFF
Linear res mode 3-76, 3-80
Full range 7-34

G

GAIN & PH MGN 8-29
Gain margin 1-10
GO TO 10-5
Grabbers (digital) 13-5
Graphical help 2-2
GRID AREA 11-12
GRID PEN 11-10
GROUND CHAN 1 7-6
GROUND CHAN 2 7-6
Grounding
Analog 1-7
Grounds (digital probe) 13-5

H

HALF RANGE (Indicator LED) 7-30, A-3
HANN
Linear res mode 3-66, 6-23
Hann window
Linear res mode 3-67, 3-69
Hardkey 1-5
Hardkeys
ARM 1-14
AUTO SEQ 1-13
AUTOMATH 1-12
AVG (average) 1-8
CAL (calibration) 1-8
COORD 1-9
CURVE FIT 1-12
DISC 1-14
ENGR UNITS 1-8
FREQ 1-8
HELP 1-15
HP-IB FCTN 1-14
INPUT CONFIG 1-8
LOCAL 1-14
MARKER VALUE 1-11
MATH 1-12

MEAS DISP 1-9
MEAS MODE 1-8
PAUSE/CONT 1-13
PLOT 1-14
PRESET 1-13
RANGE 1-8
SAVE/RECALL 1-13
SCALE 1-9
SELECT MEAS 1-8
SELECT TRIG 1-8
SOURCE 1-8
SPCL FCTNS 1-13
SPCL MARKER 1-10
START 1-13
STATE/TRACE 1-9
SYNTH 1-12
TRIG DELAY 1-8
UNITS 1-9
VIEW INPUT 1-9
WINDOW 1-8
X (marker) 1-10
X OFF 1-10
Y (marker) 1-10
Y OFF 1-10
Harmonic markers 1-10, 8-27
Harmonic power 8-27
Help
state display 7-10
visual 2-2
visual, displaying 7-10
Help block (key group) 1-15
HELP hardkey 1-15
Helptext 2-2
HIST
Linear res mode 3-32
Time capture mode 6-17
HIST 1
Linear res mode 3-49 - 3-50
Time capture mode 6-22
HIST 2
Linear res mode 3-49 - 3-50
Time capture mode 6-22
Histogram 2-6
Histogram measurement
Linear res mode 3-49
Time capture 6-15, 6-22
HMNC ON 8-26 - 8-27
HMNC POWER 8-27
HOLD RIGHT 8-20
HOLD X CENTER 8-20 - 8-21
HOLD X LEFT 8-20
HOLD X OFF 8-20

- HOLD X softkeys
 - Description 8-19 - 8-21
 - Use in creating bands 8-18
 - Use in relative measurements 8-24
- HOLD Y CENTER 8-23
- HOLD Y LOWER 8-23
- HOLD Y OFF 8-23
- HOLD Y softkeys
 - Descriptions 8-22 - 8-23
 - Use in creating bands 8-18
 - Use in relative measurements 8-24
- HOLD Y UPPER 8-23
- HP logo, plotting 11-8
- HP-IB
 - abort 11-3
 - HP-IB (Connector) A-6
 - HP-IB ADDRES 11-3
 - HP-IB addresses 11-3
 - HP-IB block (key group) 1-14
 - HP-IB FCTN 11-2
 - HP-IB FCTN hardkey 1-14
 - HP-IB TRIG 7-39
 - Hz (Sec) 8-9
- I
- I/O, general signal 13-2
- IMAG 8-6
- IMAGE BACKUP 11-25, 11-27
- IMPLS RESP
 - Linear res mode 3-35
- INIT CATLOG 11-24
- INIT DISC 11-24
- Initializing discs 11-24
- Input
 - Front-panel connector grounding 1-7
 - Maximum signal level (analog) 1-7
 - Input cables (digital) 13-3
 - Input calibration 7-43 - 7-44
 - INPUT CONFIG
 - menu diagram 7-4
 - softkey descriptions 7-21
 - INPUT CONFIG hardkey 1-7 - 1-8
 - Input Configuration Menu 7-4
 - Input data path
 - selecting 7-9
 - INPUT DIG 1 3-6
 - INPUT DIG 2 3-7
 - Input pods 13-11
 - Input range 7-28 - 7-36
 - setting 7-28
 - Input setup, introduction 7-1
 - INPUT SPEC 1
 - Linear res mode 3-6
 - INPUT SPEC 2
 - Linear res mode 3-6
 - INPUT TIME 1
 - Linear res mode 3-6
 - INPUT TIME 2
 - Linear res mode 3-6
 - Input, setting up
 - Time capture 6-7
 - Inputs
 - analog data, configuring 7-5
 - block diagram 7-7
 - configuring 7-4
 - digital data, configuring 7-7
 - floating/grounding 7-6
 - setup procedures 7-9
 - Inputs, setting up 7-1
 - Throughput 9-14
- INST
 - Linear res mode 3-73, 3-83
 - Time capture 6-19
- INST WINDOW
 - Linear res mode 3-73, 3-83
- Instantaneous displays 2-10
 - linear res mode 3-4 - 3-7
- Integration 15-10
- Integration (swept sine mode) 5-30 - 5-33
- INTERFACE 3-12
- INTERFACE 1 7-21
- INTERFACE 2 7-22
- Interface Menu 7-23
 - softkey descriptions 7-23
- Intergration time (swept sine mode) 5-32
- INTGRT 15-4, 15-10
- INTGRT INIT = 0 15-10
- INTGRT TIME (swept sine mode) 5-31
- Inverse FFT 15-1
- J
- jw 15-4
- jw-1 15-4
- K
- Key groups 1-7
- Knob (entry block) 1-11
- L
- l 3-63
- L SPEC UNITS 8-9 - 8-10
- LABEL ASEQ 10-4, 10-11
- LABEL MATH 15-20, 15-22
- Labeling auto sequences 10-11
 - When saved to disc 10-12

Index

LAST 10 7-25
LAST 10 softkey 13-12
LAST MEAS 16-49
Layout, rear panel 13-2
Leakage
 defined 3-66, 6-23
 With source output signals 3-13
Least-significant byte (LSB) 13-12, 13-16
Lin res mode 2-4
LIN X 8-7
LINE A-3
LINE A TYPE# 11-11
LINE B TYPE# 11-11
LINE TYPES 11-8, 11-11
 Default state 11-9
Linear averaging
 Linear res mode 3-78
LINEAR RES 3-3
 To activate throughput 9-12
Linear resolution mode 3-1
 Comparison to Log res mode 4-1
 Introduction to 3-1
 measurement overview 2-1
LINEAR SPEC 6-9
LINEAR SPEC 1
 Linear res mode 3-83, 3-85
 Time capture 6-19
LINEAR SPEC 2
 Linear res mode 3-83, 3-85
 Time capture 6-19
Linear spectrum displays
 Linear res mode 3-85
LINEAR SWEEP 5-4
LINES 1024 3-59, 3-67, 6-23
LINES 801 3-59, 3-67, 6-23
LINRES FRF 10-6
LISTEN (Indicator LED) A-3
LN OF DATA 15-5, 15-13
LN-1 OF DATA 15-5, 15-14
LOAD ALL 10-8
LOAD ASEQ 10-5
LOCAL hardkey 1-14
LOG RES
 Log res mode 4-6
 To activate Time throughput 9-12
Log res mode 2-4
Log resolution mode
 Comparison to Linear res mode 4-1
 Introduction to 4-1
 measurement overview 2-1
 Measurement process in 4-4
LOG SWEEP 5-23
Log sweeps 5-4

LOG X 8-7
Loge 15-13
LOOP TO 10-5, 10-10
LOW 13 BITS 7-24

M

MAG (dB) 8-6
MAG (dBm) 8-6
MAG (LIN) 8-6
MAG (LOG) 8-6
Manual Arming 7-42
Manual arming vs auto arming 7-42
MANUAL PRVIEW 3-76, 3-80
Manual sweep 5-9 - 5-10
Marker bands
 Creating 8-18
MARKER CALC 8-26, 8-29
Marker Calculation Menu 8-29
Marker fields on display 8-2
MARKER PEN 11-10
MARKER VALUE 8-18
MARKER VALUE hardkey 1-11
Markers
 calculations 8-29
 Introduction to 8-18
Markers
 Duplicated softkeys in SCALE 8-13
Markers block (key group) 1-10
Markers knob 8-18
Math 15-1 - 15-17
 Use in auto math 15-18
MATH hardkey 1-12
Math, overview 15-1 - 15-24
MAX SPAN
 Linear res mode 3-57
Maximum input signal level 1-7
MEAS CLOCK 16-53
MEAS DISP
 Linear res mode 3-35, 3-42, 3-46, 3-48, 3-50 - 3-52,
 3-84 - 3-86, 5-17
 Log res mode 4-15, 4-22 - 4-23
 Swept sine mode 5-15
 Time capture mode 6-20 - 6-21
 Use in auto math 15-18
 With other display features 8-16
MEAS DISP hardkey 1-9

MEAS MODE

- Activating Linear res mode 3-3
- Activating Log res mode 4-6
- Activating Swept sine mode 5-3
- Activating Time capture mode 6-5
- Activating Time throughput 9-12
- For CAPTUR SELECT menu 6-13
- For DEMOND SELECT menu 3-91
- For THRUPT SELECT menu 9-12
- In auto sequences 10-1
- MEAS MODE hardkey 1-8
- Measurement
 - Block (key group) 1-8
- Measurement displays
 - auto correlation 3-45
 - cross correlation 3-47
 - filtered input 3-82, 6-19
 - Frequency response 3-35, 5-17
 - histogram 3-49, 6-22
- Measurement displays, selecting
 - Linear res mode 3-42
 - Log res mode 4-15, 4-22
 - Time capture mode 6-20 - 6-21
- Measurement mode
 - linear resolution 3-1
- Measurement Modes
 - Variant menus 2-5
- Measurement overview 2-1
- Measurement process 2-6
- Measurement setup
 - Linear resolution 3-2
 - Log resolution 4-2
 - overview 2-2
 - Swept sine 5-2
 - Time capture 6-2
- Measurement with averaging off
 - Linear res mode 3-76
- Measurements
 - available 2-6
 - measurement modes 2-6
 - setting up 2-1
- Measurements, selecting
 - Linear resolution mode 3-30 - 3-52, 4-10 - 4-23
 - Log res mode 4-10
 - Swept Sine mode 5-15 - 5-22
 - Time capture mode 6-15
- MEASURING (Indicator LED) A-4
- Menu Diagram
 - definition 1-5
- MENU ON OFF 12-6
- Menus (definition of term) 1-5
- MIXED RATIO 7-27
 - softkey 7-27

Modes

- A comparison 2-4
- Linear resolution 3-1, 3-3
- Log resolution 4-1, 4-6
- Overview 2-4
- Swept sine 5-1, 5-3 - 5-4
- Time capture 6-1, 6-5
- MORE TYPES 3-14
- Most-significant byte (MSB) 13-12, 13-16
- Moving 16-bit data on an 8-bit bus 13-12
- Moving digital data 13-3 - 13-10
- MPY 15-4
- MRKR - 8-26
- Multiplication 15-4

N

- Narrow band correction
 - Flat top window 3-70
 - Hann window 3-69
- Natural antilog 15-14
- Natural log 15-13
- NEGATE 15-4, 15-9
- Negation 15-9
- NEXT PAGE (DISC menu) 11-18
- NEXT PAGE (disc service) 11-28
- NICHOL
 - Scaling 8-15
 - Selecting 8-7
- NMBR ? ON OFF 12-6
- NO PAGING 11-12
- NO(0)
 - With previewing 3-80
- Normalizing a waveform 3-22
- NUMBER AVGS
 - Linear res mode 3-75
 - Swept sine mode 5-31
- NUMBER POLES 16-48
- NUMBER ZEROS 16-48
- Numeric keypad 1-11
- NYQUST
 - Scaling 8-15
 - Selecting 8-7

O

- OFFSET BINARY 3-12, 7-23
- Offset binary number format 7-14
- Open-loop response, calculating 15-12
- Operators block (key group) 1-12
- Orbit diagram 3-86
- Orbits diagram 3-83

Index

- ORBITS T1vsT2
 - Linear res mode 3-83, 3-86
 - Scaling 8-15
 - With COORD menu 8-4
- Orders (Revs) 8-9
- Orders CAL 8-9
- Out-of-band excitation, Linear res mode 3-8
- Output cables (digital) 13-4
- OUTPUT LOG (disc service) 11-28
- OUTPUT STRING 11-3, 11-38
- Output strings 11-38
- OV REJ ON OFF
 - Linear res mode 3-76, 3-80
- OVER RANGE (Indicator LED) 7-30, A-4
- OVER WRITE 11-19
- Overflow 14-8
- Overflow signal 13-15
- Overlap processing
 - Linear res mode 3-76, 3-79
 - Log res mode 4-5
 - Time capture 6-25
- Overload rejection 7-32
 - Linear res mode 3-76
 - Time capture 6-25
 - Time throughput 9-16
- Overload vs overflow 14-8
- Overloads
 - analog channel 7-29
 - time throughput 7-32
- OVERWR AU MAN 11-25 - 11-26
- OVF signal 13-15, 14-8
- OVL RP%
 - Linear res mode 3-76, 3-79
- P**
- P SPEC LINRES 12-10
- P SPEC UNITS 8-9 - 8-10
- P1 (plotter pen location) 11-13
- P2 (plotter pen location) 11-13
- PACK DISC 11-23
- PAGE BACK 11-12
- PAGE FORWRD 11-12
- PAGING CONTRL 11-8, 11-12
 - Default state 11-9
- Parital-sample delay 14-6
- Part numbers
 - Digital accessories 13-8
- PAUSE ASEQ 10-11
- PAUSE CONT
 - With averaging 3-77
- PAUSE/CONT hardkey 1-13
- PDF 1
 - Linear res mode 3-49, 3-51
 - Time capture mode 6-22
- PDF 2
 - Linear res mode 3-49, 3-51
 - Time capture mode 6-22
- Peak continuous function
 - Linear res mode 3-77
- PEAK HOLD
 - Linear res mode 3-75
- Peak hold function
 - Linear res mode 3-77
- Pen numbers 11-10
- Periodic chirp
 - Linear res mode 3-18
- PHASE
 - Dependence on scaling 8-6
 - Selecting 8-6
 - where referenced 7-41
 - With frequency response measurement 3-35, 5-17
- Phase margin 1-10
- Pin-strip header 13-7
- PLOT 11-7
- PLOT ADDRESS 11-3
- PLOT AREA 11-12
- PLOT hardkey 1-14
- PLOT LIMITS 11-8, 11-12
 - Default state 11-9
- PLOT PRESET 11-8 - 11-9
- Plotters
 - Addressing 11-6
 - connecting 11-5
- Plotting
 - Connecting and addressing 11-5
 - Introduction 11-5 - 11-13
- PM demodulation 3-92 - 3-94
- PM/FM CARRIER 3-89, 3-94
- Pod 1 13-11
 - two-channel measurements 7-17
- Pod 2 13-11
- Pod assembly 13-7
- POD Q CLOCK 7-26, 13-15
 - Linear res mode 3-64
- Pod X 13-18
- POINTR INCRMT 6-7, 6-13
- Post-trigger delay 7-42
- POWER 8-29
- Power (marker function) 1-10
- POWER SPEC
 - Linear res mode 3-32, 3-42
 - Log res mode 4-12, 4-21
 - Time capture mode 6-17, 6-19

POWER SPEC 1

- Linear res mode 3-35, 3-42, 6-20
- Log res mode 4-15, 4-22 - 4-23
- Swept sine mode 5-17

POWER SPEC 2

- Linear res mode 3-35, 3-42, 6-20
- Log res mode 4-15, 4-22 - 4-23
- Swept sine mode 5-17

Power spectrum 2-6

Power spectrum averaging 3-78

Power spectrum display

- Linear res mode 3-39, 3-43
- Log res mode 4-19, 4-23
- Swept sine mode 5-21

Power spectrum measurement

- Linear res mode 3-42
- Log res mode 4-21
- Time capture 6-17

Power spectrum units menu 8-10

Power-down state, recalling 8-33

Power-on SRQ 12-4

Pre-trigger delay 7-42

PRESET

- Plot preset 11-9

PRESET ASEQ 10-6 - 10-8

Preset auto sequences 10-6 - 10-8

Preset conditions 12-1

PRESET hardkey 1-13, 12-7 - 12-12

PREV PAGE (DISC menu) 11-18

Previewing, linear resolution 3-80

PRIODC CHIRP

- Linear res mode 3-13

Probe adapter 13-7

Probe ground 13-5

PROTECT ON OFF 12-5

- Linear res mode 3-29

PRVIEW OFF 3-76

PRVIEW ON OFF 3-89, 3-95

PULSE 3-15

Pulse signal

- Linear res mode 3-19

Pulses/rev 3-65

Pwr SRQ ON OFF 12-4

Q

Q-CLK 13-15

Qualifier bit Q0 13-12

Qualifiers 14-4

- disabling 7-16
- operation of 7-16
- setting pattern 7-16
- setting up 7-15

Quantization distortion 14-8

R

RAMP 3-15

Ramp signal

- Linear res mode 3-19

RAMP TIME 12-5

- Linear res mode 3-29

RANDOM NOISE

- Linear res mode 3-13

Random noise signal

- Linear res mode 3-13, 3-19

RANGE 7-28 - 7-36

- analog channel 7-29
- analog channels 7-29
- choosing best, analog channel 7-31
- digital channels 7-33
- digital data 7-33
- setting 7-28

Range (digital) 7-34

RANGE hardkey 1-8

Range menu

- digital data 7-35
- digital data, swept sine mode 7-35

RC network (digital cable) 13-5

READ PEN - 11-13

REAL 8-6

REAL PART 15-5, 15-12

Real time bandwidth

- Definition 3-62
- Demodulation 3-87
- Linear res mode 3-39, 3-42, 3-62
- Log res mode 4-5, 4-19, 4-21, 4-28
- Relation to overlapping 3-79
- Time capture 2-4
- Time throughput 9-5

Real time message 3-62, 4-28

Rear panel layout 13-2

RECALL DATA# 8-33

Recall data/state 1-13

RECALL FILE 11-18, 11-21 - 11-22

RECALL PWR DN 8-33

Recall state at last power shutdown 1-13

RECALL STATE# 8-33

Recalling files from disc 11-21

Recalling from local memory 8-32

RECIP 15-4

REF CHAN 1 5-12

REF CHAN 2 5-12

REF IN (connector) A-6

REF LEVEL 5-12

Reference channel (swept sine) 5-12

Relative marker measurements 8-24

REMOTE (Indicator LED) A-4

REPEAT 3-15

Index

- Reset 12-1, 12-11
- RESET softkey 1-13
- RESLTN 5-26, 5-29
- RESLTN AU FIX 5-26, 5-29
- Resolution, frequency
 - Linear res mode 3-53 - 3-65
 - Log res mode 4-3
 - Swept sine mode 5-28
- RESTOR CATLOG 11-28, 11-30
- Restoring catalogs 11-30
- RESUME COPY 11-25 - 11-26
- RESUME OVERWR 11-25 - 11-26
- RNG 1: digital operation 7-35
- RO ERT TEST 11-28, 11-31
- ROT 90 ON OFF 11-12
- RPM (Sec) 8-9
- Run time log 11-33
- RUN TM LOG 11-28

- S**
- Sample clock 7-23, 13-19 - 13-23, 14-4
 - and source types 3-8
 - block diagram 7-18
 - both channels connected to Pod 1 7-19
 - Chan 1 Clock 7-26
 - Chan 2 Clock 7-27
 - configuring 7-18
 - EXT SAMPLE 7-26
 - See also External sampling frequency 7-20, 7-27
 - information, where to find 7-20
 - Linear res mode 3-57
 - menu 7-23, 7-26
 - Pod Q clock 7-26
 - selecting 7-18
- Sample clock menu 7-26
- Sample clock, choosing 14-6
- Sample clocks
 - available 7-18
- SAMPLE FREQ 7-27, 16-53
 - Linear res mode 3-57, 3-65, 4-26
 - Swept sine mode 5-26
- Sample out (pod X signal) 13-18
- Sampling rate
 - With external sampling 3-64
- SAVE DATA# 8-33
 - Saving user-defined windows 3-73
- SAVE RECALL 8-32
 - Storing user-defined windows 3-73
- SAVE RECALL hardkey 1-13
- SAVE STATE# 8-33
- Save state/data 1-13
- SAVED # 15-6
- SAVED 1 15-6
- SAVED 2 15-6
- Saving & recalling states and traces
 - Local memory 8-32
- Saving auto sequences to disc 10-12
- SBAND INCRMT 8-28
- SBAND ON 8-26, 8-28
- SBAND POWER 8-28
- SCALE 8-3, 8-13
- SCALE FREQ 16-52
- SCALE hardkey 1-9
- SCOLL ON OFF
 - Description 8-20
- SCROLL ON OFF
 - Example 8-21
- Scrolling display traces 8-21
- SELECT ADDRES 11-3
 - For disc drives 11-16
 - For plotters 11-5
- SELECT ASEQ # 10-3
- SELECT DATA (plotting) 11-8 - 11-9
 - Default state 11-9
- Select Data keys 8-16
- SELECT MEAS
 - In auto sequences 10-1
 - Linear res mode 3-35, 3-42, 3-44, 3-47
 - Log res mode 4-15, 4-21
 - Time capture mode 6-19, 6-21
 - Time throughput 9-16
- SELECT MEAS hardkey 1-8
- SELECT PENS 11-8, 11-10
- SELECT TRIG 7-37
- SELECT TRIG hardkey 1-8
- Selecting clocks and qualifiers 14-4
- Selecting disc files 11-26
- SELF TEST 12-3
- Self-tests 1-13
 - See also Installation Guide
- SERVIC TEST 12-3
- SERVICE FCTNS (disc service only) 11-23, 11-28
- Service requests
 - at power-on 12-4
- Service tests 12-3
- SET P1 LWR LF 11-13
- SET P2 UPR RT 11-13
- Setup diagrams 12-4
- Setup procedures
 - Linear resolution 3-2
 - Log resolution 4-2
 - overview 2-2
 - Swept sine 5-2
 - Time capture 6-2
- Sideband 1-10

- Sideband markers 8-28
- Sideband power 8-28
- SINGLE 3-15, 8-3
- SINGLE CAL 7-43
- SLOPE 8-26
- Slope (marker function) 1-10
- SLOPE + - 7-39
- SMP-OUT (pod X signal) 13-18
- Softkey menu (definition) 1-5
- Softkey types 1-5
- Softkeys 1-5
- SOLID GRIDS 11-9
- SOLID LINES 11-11
- SOLIDA DASH B 11-11
- SOUCE TRIG 7-39
- Source
 - arbitrary 3-19 - 3-20
 - arbitrary, example 3-22
 - User Saved 2 3-20
 - arbitrary, normalizing 3-22
 - arbitrary, restrictions 3-20
 - Clock signal 13-18
 - Enable signal 13-18
 - Linear res mode 3-8 - 3-29
 - Log res mode 4-8 - 4-9
 - swept sine 5-7
 - Swept sine mode 5-7 - 5-13
 - throughput 9-16
 - Time capture 6-9, 9-16
 - Time capture mode 6-9
 - tracking resolution 5-12
 - types available 2-18
- SOURCE (connector) A-4
- SOURCE (Indicator LED) A-4
- SOURCE AN DIG 3-10 - 3-11
- SOURCE CHANGE 5-12
- SOURCE hardkey 1-8
- SOURCE LEVEL
 - Linear res mode 3-10 - 3-11
- SOURCE LIMIT (swept sine) 5-12
- SOURCE OFF
 - Linear res mode 3-10, 3-12 - 3-13
- SOURCE ON OFF 5-9
- Source Output
 - limiting, swept sine 5-13
- Source output signals, selecting
 - Linear res mode 3-8
 - Linear resolution 3-8
 - Log resolution 4-8
 - Swept sine 5-7
 - Time capture 6-9, 9-16
- SOURCE PROTCT 12-4
 - Linear res mode 3-29
- Source protection 12-5
 - Linear res mode 3-29
 - Swept sine mode 5-7
- SOURCE QUALFR 3-12
- Source qualifiers 14-5
- SOURCE RANGE 3-12
- SOURCE RNG 2: digital operation 7-35 - 7-36
- SOURCE TYPE 3-10, 3-12
- Source types
 - and sample clock 3-8
 - available 2-18
 - Linear res mode 3-8, 3-13
 - Log res mode 4-8
 - Swept sine mode 5-9
 - Time capture mode 6-9
 - triggering from 7-38
- Span
 - valid, linear res mode 3-59
 - valid, log res mode 4-27
 - valid, swept sine mode 5-27
- SPARE BLOCK 11-28, 11-34
- Sparring blocks 11-34
- SPCL FCTN 3-29
- SPCL FCTN Hardkey 12-2 - 12-6
- SPCL FCTNS hardkey 1-13
- SPCL MARKER 8-25
- SPCL MARKER hardkey 1-10
- Special Functions 12-1
- Special marker functions 1-10
- Special markers 8-25
- SPEED F S 11-8
- Square pin connector 13-7
- SQUARE ROOT 15-4, 15-8
- SRC-CLK (pod X signal) 13-18
- SRC-CLK signal 13-16
- SRC-EN (pod X signal) 13-18
- SRC-EN (source enable signal) 14-5
- SRQ (Indicator LED) A-4
- Stability, clock 14-18
- STABLE (MEAN)
 - Linear res mode 3-75
- Stable (rms) averaging
 - Linear res mode 3-74 - 3-81
- START
 - Demodulation 3-91
 - In auto sequences 10-10
 - Time capture 6-27
- START CAPTUR 6-7, 6-12
- START FIT 16-49
- START FREQ
 - Linear res mode 3-57
 - Log res mode 4-24
 - swept sine mode 5-26

Index

START hardkey 1-13
START MATH 15-20, 15-23
START PLOT 11-8
Start points
 Capture measurements 6-27
 Throughput measurements 9-20
START THRUPT 9-12, 9-17
Starting captures 6-12
Starting measurements
 Demodulation 3-91
 Time capture 6-25
 Time throughput 9-21
Starting throughputs 9-17
State display 7-10, 8-16
STATE TRACE 8-16
STATE/TRACE hardkey 1-9
Status block (key group) 1-14
STEP 3-15
STEP RESPNS 10-7
Step signal
 Linear res mode 3-19
STOP FIT 16-49
STOP FREQ 5-26
Storage registers 1 through 5 1-13
STORE WEIGHT 16-57
SUB 15-4, 15-8
SUBBrocation 15-8
Subtraction 15-4
SWEEP DOWN 5-9
 sweep hold 5-9
SWEEP RATE 5-9, 5-26, 5-28
SWEEP UP 5-9
SWEPT FRF 10-7
SWEPT SINE 5-3
Swept sine mode 2-4
 measurement overview 2-1
 Setting up 5-3
SWEPT UNITS 8-9, 8-11
SYNC OUT (connector) A-7
SYNTH - FIT 16-55
SYNTH hardkey 1-12
SYSTEM CNTRLR 11-3

T

T/1 - T 15-12
T/1-T 15-4
TABLE FCTNS 16-51
TALK (indicator LED) A-4
Tape drives 11-14
Termination adapter (digital) 13-9
Terms 1-5 - 1-6
THD 8-27

Throughput
 Activating 9-12
 Data collection 9-10 - 9-18
 Opening throughput files 9-7 - 9-9
 Overview 9-4
 Selecting throughput channels 9-16
 throughput session 9-10
 using capture blocks 6-28
Throughput data
 Measuring 9-19 - 9-21
 Viewing 9-19
Throughput files
 Naming 9-9
 Setting size 9-8
Throughput header 9-18
THRUPT HEADER 9-12, 9-18
THRUPT LENGTH
 Relation to THRUPT SIZE 9-12
 Setting length 9-16
THRUPT ON OFF 9-12
THRUPT SELECT 9-12
THRUPT SIZE 9-7 - 9-9, 9-16 - 9-17
 Relation to THRUPT LENGTH 9-16, 11-23
TICK MARKS 11-9
Time and date settings 1-13
TIME BUFFER 6-12, 6-27
Time buffer-display 6-13
TIME CAPTUR 6-5, 12-10
TIME CAPTUR (MEAS MODE menu) 6-13
Time capture
 and throughput 6-28
Time capture mode 2-4, 6-3
 measurement overview 2-1
 Overview 6-4
TIME DELAY 16-52
TIME H, M, S 12-3
TIME LENGTH
 Linear res mode 3-57
TIME REC 1
 Linear res mode 3-83 - 3-84
 Time capture 6-19
TIME REC 2
 Linear res mode 3-83
 Time capture 6-19
Time record
 Demodulation 3-87
 In overlap processing 3-79
 Linear res mode 3-84
 Time capture 6-9
TIME RECORD (capture bufferdisplays)6-9,6-13

- Time record length
 - Formula for 3-63
 - How to set 3-56
 - Linear res mode 3-84
 - Time throughput 2-6
 - TIME THRUPT 12-11
 - TIMED PAUSE 10-5
 - TIMED PRVIEW 3-76, 3-80
 - TIMED START 10-5
 - Timing between clocks 13-19
 - TM AVG ON OFF
 - Linear res mode 3-75
 - Trace
 - coordinates and units 2-13
 - Trace A 15-6
 - TRACE A PEN 11-10
 - Trace B 15-6
 - TRACE B PEN 11-10
 - TRACE TITLE 8-12
 - Transform (FFT) 15-15
 - Tri-state signal 14-5
 - TRIG ARMED (indicator LED) A-4
 - TRIG DELAY hardkey 1-8
 - TRIG LEVEL 7-38, 7-41
 - TRIG signal 13-15
 - Trigger
 - arming 7-42
 - delaying 7-42
 - operation 7-40
 - setting up 7-37
 - slope 7-39
 - softkeys 7-38
 - Trigger conditions 7-41
 - level and slope 7-41
 - Trigger delay 7-42
 - Time throughput 9-8, 9-20
 - Trigger signals
 - reliability 7-41
 - Triggering 7-38
 - conditions 7-41
 - TRIGGERING (Indicator LED) A-4
 - Truncation (of digital data) 14-8
 - TWOS COMPL 3-12, 7-23
 - Twos-complement number format 7-14
 - Types of softkeys 1-5
- U**
- UNFIX LINE # 16-51
 - Uniform window
 - Linear res mode 3-67, 3-70
 - UNIFRM (NONE)
 - Linear res mode 3-67
 - Units 2-13, 8-3, 8-8 - 8-12
 - available 2-14
 - Combining with coordinates 8-4
 - Selecting 8-8, 8-10
 - vertical axis 2-15
 - UNITS hardkey 1-9
 - Up/down arrow keys 1-11
 - UPPER LOWER 8-3
 - UPR 13 BITS 7-24
 - USER CARRIER 3-89, 3-94
 - USER LIMITS 11-12 - 11-13
 - USER LINES 11-11
 - USER ORDER 16-54
 - USER SAVD 2 3-15
 - USER SAVD1
 - Linear res mode 3-67, 3-73
 - User service requests 11-4
 - USER SRQ 11-3
 - USER WEIGHT 16-54
 - User-defined windows
 - Linear res mode 3-68, 3-73
 - User-Saved-2
 - Linear res mode 3-19
- V**
- V//Hz (/PSD) 8-10
 - V/Hz (PSD) 8-10
 - V2/Hz(psd)
 - Power spectrum units menu 8-10
 - V2s/Hz(esd)
 - Power spectrum units menu 8-10
 - Variant menus
 - measurement mode 2-5
 - VIEW 10-3
 - VIEW CATLOG 11-18, 11-21
 - View input displays
 - Linear res mode 3-4
 - Log res mode 4-7
 - Swept sine mode 5-5
 - Time capture mode 6-7
 - Time throughput 9-14
 - VIEW INPUT hardkey 1-9
 - VIEW MATH 15-20
 - VIEW OFF
 - Linear res mode 3-7
 - VIEW WEIGHT 16-56
 - Viewing windowed data 3-73
 - Visual help 1-13, 12-4, 12-6
 - Voltage selection A-7
 - VOLTS
 - Power spectrum units menu 8-10
 - Swept units menu 8-11
 - VOLTS CHAN1 7-45

Index

VOLTS CHAN2 7-45

VOLTS PEAK

Power spectrum units menu 8-10 - 8-11

VOLTS RMS

Linear spectrum units menu 8-10

power spectrum units menu 8-10

swept units menu 8-11

VOLTS2 2-16, 8-10 - 8-11

W

Waveform math 15-1 - 15-17

WEIGHT REGION 16-56

WEIGHT VALUE 16-57

WINDOW hardkey 1-8

Windows

Time capture mode 6-23

Windows selecting

linear res mode 3-66 - 3-73

log res mode 4-1, 4-4

Use with source outputs 3-13, 3-69

X

X (indicator LED) A-5

X (key) 8-18 - 8-19

X (marker) hardkey 1-10

X AUTO SCALE 8-14 - 8-15, 8-20

X FCTN OFF 8-26

X FIXD SCALE 8-14 - 8-15

X marker 8-19

X MRKR SCALE 8-14 - 8-15, 8-20 - 8-21

X OFF hardkey 1-10

X OVFL ON OFF 7-24

X OVFL ON/OFF softkey 13-15

X VALUE

Description 8-20

Use in creating bands 8-18

X-axis scaling 8-15

Y

Y (marker) hardkey 1-10

Y AUTO SCALE 8-14 - 8-15, 8-23

Y DFLT SCALE 8-14 - 8-15, 8-23

Y FIXD SCALE 8-14 - 8-15

Y marker 8-22 - 8-23

Y MRKR SCALE 8-14 - 8-15, 8-23

Y OFF hardkey 1-10

Y VALUE

Use in creating bands 8-18

Y VALVE

Description 8-23

Y (Indicator LED) A-5

Y (key) 8-18, 8-22

Y-axis scaling 8-15

YES (1)

With previewing 3-80

Z

ZERO START

Linear res mode 3-57

Zero-fill 14-12

Zero-order hold example 14-16

Zoom measurements 3-63

Hewlett-Packard Sales and Service Offices

To obtain Servicing information or to order replacement parts, contact the nearest Hewlett-Packard Sales and Service Office listed in HP Catalog, or contact the nearest regional office listed below:

In the United States

California

P.O. Box 4230
1421 South Manhattan Avenue
Fullerton 92631

Georgia

P.O. Box 105005
2000 South Park Place
Atlanta 30339

Illinois

5201 Tollview Drive
Rolling Meadows 60008

New Jersey

W. 120 Century Road
Paramus 07652

In Canada

Hewlett-Packard (Canada) Ltd.
17500 South Service Road
Trans-Canada Highway
Kirkland, Quebec H9J 2M5

In France

Hewlett-Packard France
F-91947 Les Ulis Cedex
Orsay

In German Federal Republic

Hewlett-Packard GmbH
Vertriebszentrale Frankfurt
Berner Strasse 117
Postfach 560 140
D-6000 Frankfurt 56

In Great Britain

Hewlett-Packard Ltd.
King Street Lane
Winnersh, Wokingham
Berkshire RG11 5AR

In Other European Countries

Switzerland

Hewlett-Packard (Schweiz) AG
7, rue du Bois-du-Lan
Case Postale 365
CH-1217 Meyrin

In All Other Locations

Hewlett-Packard Inter-Americas
3155 Porter Drive
Palo Alto, California 94304

