



**HEWLETT  
PACKARD**

**OPERATING MANUAL**

**3776B**

**PCM TERMINAL TEST SET**

**(Including Options 001, 002 and 004)**

**SERIAL NUMBER**

This manual applies directly to instruments with serial numbers prefixed 2309U and includes update information which applies to instruments with serial numbers 2404U-00242 and above.

For additional important information about serial numbers, see INSTRUMENTS COVERED BY MANUAL in Section 1.

© Copyright HEWLETT-PACKARD LIMITED 1984  
SOUTH QUEENSFERRY, WEST LOTHIAN, SCOTLAND

Manual Part Number 3776-90003  
Microfiche Part Number 3776-90028

Printed: April 1984



## WARNING

*READ THE FOLLOWING NOTES BEFORE INSTALLING OR SERVICING THE INSTRUMENT.*

1. IF THIS INSTRUMENT IS TO BE ENERGIZED VIA AN AUTO-TRANSFORMER MAKE SURE THAT THE COMMON TERMINAL OF THE AUTO-TRANSFORMER IS CONNECTED TO THE NEUTRAL POLE OF THE POWER SOURCE.
2. THE INSTRUMENT MUST ONLY BE USED WITH THE MAINS CABLE PROVIDED. IF THIS IS NOT SUITABLE, CONTACT YOUR NEAREST HP SERVICE OFFICE. THE MAINS PLUG SHALL ONLY BE INSERTED IN A SOCKET OUTLET PROVIDED WITH A PROTECTIVE EARTH CONTACT. THE PROTECTIVE ACTION MUST NOT BE NEGATED BY THE USE OF AN EXTENSION CORD (POWER CABLE) WITHOUT A PROTECTIVE CONDUCTOR (GROUNDING).
3. THE SERVICE INFORMATION FOUND IN THIS MANUAL IS OFTEN USED WITH POWER SUPPLIED TO AND PROTECTIVE COVERS REMOVED FROM THE INSTRUMENT. ENERGY AVAILABLE AT MANY POINTS MAY, IF CONTACTED, RESULT IN PERSONAL INJURY.
4. BEFORE SWITCHING ON THIS INSTRUMENT:
  - (a) Make sure the instrument input voltage selector is set to the voltage of the power source.
  - (b) Ensure that all devices connected to this instrument are connected to the protective (earth) ground.
  - (c) Ensure that the line power (mains) plug is connected to a three-conductor line power outlet that has a protective (earth) ground. (Grounding one conductor of a two-conductor outlet is not sufficient).
  - (d) Check that the instrument fuse(s) is of the correct type and rating.
5. SERVICING INFORMATION:
  - (a) This manual contains information, cautions, and warnings which must be followed to ensure safe operation and to retain the instrument in safe condition. Service and adjustments should be performed only by qualified service personnel.
  - (b) Any adjustment, maintenance, and repair of the opened instrument under voltage should be avoided as much as possible and, when inevitable, should be carried out only by a skilled person who is aware of the hazard involved.
  - (c) Capacitors inside the instrument may still be charged even if the instrument has been disconnected from its source of supply.
  - (d) Whenever it is likely that the protection has been impaired, the instrument must be made inoperative and be secured against any unintended operation.



TABLE OF CONTENTS

SECTION I GENERAL INFORMATION

	Page
INTRODUCTION . . . . .	1-1
SPECIFICATION . . . . .	1-1
SAFETY CONSIDERATION . . . . .	1-1
INSTRUMENTS COVERED BY MANUAL . . . . .	1-1
DESCRIPTION . . . . .	1-2
ACCESSORIES SUPPLIED . . . . .	1-3
EQUIPMENT AVAILABLE . . . . .	1-3
OPTIONS . . . . .	1-4
Index to Specifications . . . . .	1-5
Specifications . . . . .	1-6

SECTION II INSTALLATION

	Page
INTRODUCTION . . . . .	2-1
INITIAL INSPECTION . . . . .	2-1
PREPARATION FOR USE . . . . .	2-1
Power Requirements . . . . .	2-2
Line Voltage selection and Fuse . . . . .	2-2
Power Cable . . . . .	2-2
Power Receptacles . . . . .	2-2
Operating Environment . . . . .	2-3
MATING CONNECTORS . . . . .	2-3
Connector Configuration . . . . .	2-4
Front Panel Connectors . . . . .	2-4
RACK MOUNTING . . . . .	2-5
HEWLETT-PACKARD INTERFACE (HP-IB) BUS INSTALLATION . . . . .	2-6
Connection to the HP-IB . . . . .	2-6
HP-IB Interface Cables . . . . .	2-6
3776 CONFIGURATION . . . . .	2-7
3776 in TALK ONLY Mode . . . . .	2-7
3776 Configured as an Addressable Device . . . . .	2-7
HP-IB Output Format . . . . .	2-8
DIG Rx DATA OUTPUT (rear panel) Connector . . . . .	2-9
STORAGE and SHIPMENT . . . . .	2-9
Packaging . . . . .	2-9
INTERNAL BATTERY . . . . .	2-10

SECTION III GETTING STARTED

	Page
INTRODUCTION . . . . .	3-1
BEFORE GETTING STARTED . . . . .	3-1
GETTING STARTED . . . . .	3-2
The Default State . . . . .	3-2



ANALOG MEASUREMENTS . . . . .	3-3
SETTING THE ANALOG Tx TLP . . . . .	3-4
SETTING THE ANALOG Rx TLP . . . . .	3-5
RUNNING A SINGLE POINT MEASUREMENT . . . . .	3-5
STORE AND RECALL . . . . .	3-6
MULTI-POINT MEASUREMENTS . . . . .	3-7
CHANGING PARAMETERS . . . . .	3-8
INSERTING MEASUREMENT POINTS . . . . .	3-9
THE DELETE FUNCTION . . . . .	3-10
USING THE CONTROL KEYS . . . . .	3-11
DIGITAL MEASUREMENTS . . . . .	3-12
SETTING BACKGROUND PCM . . . . .	3-13
TRANSMIT TIMESLOT SELECTION . . . . .	3-14
RECEIVE TIMESLOT SELECTION . . . . .	3-14
DIGITAL TIMESLOT MANIPULATION . . . . .	3-15

SECTION IV MEASUREMENTS

SETTING UP THE INSTRUMENT CONFIGURATION

	Page
INTRODUCTION . . . . .	4-1
OPERATING MODES . . . . .	4-2
INTERFACE SETTINGS . . . . .	4-2
ANALOG TRANSMIT INTERFACE SETTING . . . . .	4-3
Analog Transmitter Impedance . . . . .	4-3
Analog Transmitter TLP . . . . .	4-3
ANALOG RECEIVE INTERFACE SETTING . . . . .	4-3
Analog Receiver Impedance . . . . .	4-3
Analog Receiver TLP . . . . .	4-3
DIGITAL TRANSMIT INTERFACE SETTING . . . . .	4-4
Synthesised or Thru PCM . . . . .	4-4
Digital Transmit Timeslot Selection . . . . .	4-4
DIGITAL RECEIVE INTERFACE SETTING . . . . .	4-4
Terminated or Monitor Input . . . . .	4-4
Digital Receive Timeslot Selection . . . . .	4-5
PCM FORMAT . . . . .	4-5
Signalling . . . . .	4-5
Code . . . . .	4-5
Frame Format . . . . .	4-5
SETTING FRAMING AND SIGNALLING BITS . . . . .	4-5
SETTING BACKGROUND PCM . . . . .	4-6
TIMESLOT TRANSLATION . . . . .	4-6

MEASUREMENT INFORMATION

Measurement Groups . . . . .	4-7
Measurement Selection . . . . .	4-7
Table of Measurements . . . . .	4-8
Gain tone . . . . .	4-8
Gain dig mW . . . . .	4-8
Digital Tx-Rx . . . . .	4-9





Gain v frequency . . . . .	4-10
Gain v level tone . . . . .	4-11
Gain v level 2kHz sync . . . . .	4-12
Notched noise . . . . .	4-13
Idle state weighted filter . . . . .	4-13
Idle state selective . . . . .	4-14
Idle state PCM codes (coder offset) . . . . .	4-14
Idle state other filters . . . . .	4-15
Auxiliary input for level measurements . . . . .	4-15
Communication over the line under test . . . . .	4-15, appendix D
Level weighted filter . . . . .	4-16
Level selective . . . . .	4-17
Level PCM codes . . . . .	4-18
Level other filters . . . . .	4-19
Intermod 4 tone . . . . .	4-20
Intermod 2 tone . . . . .	4-21
Quantising distortion . . . . .	4-22
Envelope delay distortion . . . . .	4-23
Remodulation . . . . .	4-25
Absolute delay . . . . .	4-26
Return loss (4 W) . . . . .	4-27
Dialling . . . . .	4-27
Transients . . . . .	4-28
Framing and signalling bits . . . . .	4-30
Ft bits (normal frame) . . . . .	4-31
Fe bits (extended frame) . . . . .	4-31
Fs bits . . . . .	4-31
CRC bits . . . . .	4-32
Sig bits . . . . .	4-32
Loop timing . . . . .	4-32
Phase jitter . . . . .	4-33

## SETTING UP THE MEASUREMENT CONFIGURATION

PARAMETER SELECTION . . . . .	4-34
Changing Parameters in Multi-point Measurements . . . . .	4-34
Insertion and Deletion of Points . . . . .	4-36
STORE AND RECALL FUNCTIONS . . . . .	4-37
STORE AND RECALL WITH FRAMING,SIGNALLING AND BACKGROUND PCM . . . . .	4-38
USER DEFINED INTERFACE DEFAULT PARAMETERS . . . . .	4-39
MEASUREMENT SEQUENCES . . . . .	4-40
Continuous Measurements in Sequences . . . . .	4-41
THE COMPLETE NON-VOLATILE MEMORY . . . . .	4-42

## SECTION V MEASUREMENT MODES AND CONFIGURATIONS

INTRODUCTION . . . . .	Page 5-1
ASSOCIATED EQUIPMENT . . . . .	5-1
LOOPBACK CONFIGURATIONS . . . . .	5-1
A-D Local Coder Test . . . . .	5-1



A-A Local Coder/Decoder Test . . . . . 5-2  
 A-A Local and Remote Coder/Decoder Test . . . . . 5-2  
 D-D Local and Remote Coder/Decoder Test . . . . . 5-2  
 Coder/Decoder Test Using Digital Loopthrough . . . . . 5-3  
 PCM Terminal Testing (sequential) . . . . . 5-4  
 PCM System Digital Testing (without interrupting traffic) . . . . . 5-5  
 Simultaneous Testing of More Than One Timeslot . . . . . 5-6  
 END TO END MEASUREMENTS . . . . . 5-6  
 A-A Local Coder/Remote Decoder Test . . . . . 5-7  
 Multi Purpose End to End Testing . . . . . 5-8  
 THE AUXILIARY INPUT . . . . . 5-9  
 EXTERNAL CLOCK . . . . . 5-9  
 MONITOR OUTPUT . . . . . 5-9  
 OBTAINING HARD COPY OF MEASUREMENT RESULTS . . . . . 5-9

**SECTION VI HP-IB INFORMATION**

	Page
INTRODUCTION . . . . .	6-1
HP-IB CAPABILITY . . . . .	6-1
CALIBRATION IN REMOTE MODE . . . . .	6-2
HP-IB MESSAGES . . . . .	6-2
HP-IB COMMANDS . . . . .	6-2
HP-IB COMMAND CATEGORIES . . . . .	6-3
HP-IB ? form of commands . . . . .	6-3
HP-IB FUNCTION/MNEMONIC/CATEGORY/VALIDITY TABLE . . . . .	6-5
HP-IB key codes, quick reference . . . . .	6-6
HP-IB INPUT/OUTPUT DATA FORMATS . . . . .	6-7
HP-IB INSTRUMENT STATUS COMMANDS . . . . .	6-8
HP-IB Provide Status Output . . . . .	6-8
HP-IB SRQ Disable/Enable . . . . .	6-8
HP-IB SRQ Mask Selection . . . . .	6-8
HP-IB Report Errors . . . . .	6-9
HP-IB Measurement Parameter Output . . . . .	6-9
HP-IB Device Identification . . . . .	6-9
HP-IB INSTRUMENT CONFIGURATION COMMANDS . . . . .	6-10
HP-IB Analog Transmitter Impedance . . . . .	6-10
HP-IB Analog Receiver Impedance . . . . .	6-10
HP-IB Digital Transmit Synthesis . . . . .	6-10
HP-IB timeslot translation . . . . .	6-10
HP-IB PCM Format . . . . .	6-10
HP-IB Framing and Signalling Bits . . . . .	6-10
HP-IB Background Idle Codes . . . . .	6-11
HP-IB Digital Receive Termination . . . . .	6-11
HP-IB Operating Mode . . . . .	6-11
HP-IB Analog Transmit TLP . . . . .	6-11
HP-IB Analog Receive TLP . . . . .	6-11
HP-IB Digital Transmit Timeslot(s) . . . . .	6-11
HP-IB Digital Receive Timeslot . . . . .	6-12
HP-IB Disable/Enable Idle Cal . . . . .	6-12
HP-IB Idle State (instrument) . . . . .	6-12



HP-IB holding tone . . . . .	6-12
HP-IB Network Delay Time . . . . .	6-12
HP-IB Loudspeaker Volume . . . . .	6-12
<b>HP-IB MEASUREMENT CONFIGURATION COMMANDS . . . . .</b>	<b>6-13</b>
All Off . . . . .	6-13
Gain tone . . . . .	6-13
Gain dig mW . . . . .	6-13
Digital Tx-Rx . . . . .	6-13
Level selective . . . . .	6-14
Level weighted filter . . . . .	6-14
Level other filters . . . . .	6-15
Level PCM codes . . . . .	6-15
Idle state selective . . . . .	6-15
Idle state weighted filter . . . . .	6-16
Idle state other filters . . . . .	6-16
Idle state PCM codes (coder offset) . . . . .	6-16
Gain v level tone . . . . .	6-16
Gain v level 2kHz sync . . . . .	6-16
Gain v frequency . . . . .	6-17
Notched noise . . . . .	6-17
Quantising distortion . . . . .	6-17
Intermod 4 tone . . . . .	6-17
Intermod 2 tone . . . . .	6-17
Transients . . . . .	6-18
Return loss (4W) . . . . .	6-18
Loop timing . . . . .	6-18
Envelope delay distortion . . . . .	6-18
Remodulation . . . . .	6-19
Absolute delay . . . . .	6-19
Phase jitter . . . . .	6-19
Ft bits . . . . .	6-19
Fs bits . . . . .	6-19
Fe bits . . . . .	6-20
Sig bits . . . . .	6-20
CRC bits . . . . .	6-20
Dialling . . . . .	6-20
<b>HP-IB STORE AND RECALL FUNCTIONS . . . . .</b>	<b>6-20</b>
<b>HP-IB MEASUREMENT RUNNING COMMANDS . . . . .</b>	<b>6-20</b>
HP-IB Single Step Command . . . . .	6-20
HP-IB Repeat Command . . . . .	6-20
HP-IB Stop Command . . . . .	6-21
<b>HP-IB DATA OUTPUT COMMANDS . . . . .</b>	<b>6-21</b>
HP-IB Result Header Output . . . . .	6-21
HP-IB Result Output . . . . .	6-21
HP-IB Result Trailer Output . . . . .	6-21
HP-IB Error Output . . . . .	6-21
HP-IB Identification Output . . . . .	6-21
<b>HP-IB SEQUENCE COMMANDS . . . . .</b>	<b>6-21</b>
HP-IB Sequence, Clear Command . . . . .	6-21
HP-IB Sequence, Add Command . . . . .	6-21
HP-IB Sequence, number of measurements enquiry . . . . .	6-21
<b>HP-IB DIALLING COMMANDS . . . . .</b>	<b>6-22</b>



HP-IB Multifrequency Dialling Tones . . . . . 6-22  
 HP-IB Signalling Bit Dialling Parameter Setting . . . . . 6-23  
 HP-IB Continuous Pulse Signalling . . . . . 6-23  
 HP-IB Dial via Signalling . . . . . 6-23  
 HP-IB Multifrequency Dialling . . . . . 6-23  
 HP-IB SELF TEST COMMANDS . . . . . 6-24  
 HP-IB STATUS BYTES . . . . . 6-25  
 HP-IB NOTES ON MEASUREMENT CONTROL . . . . . 6-26

SECTION VII MANUAL UPDATE

	Page
UPDATE INFORMATION . . . . .	7-1
DEFINITION OF UNITS . . . . .	APPENDIX A
PCM FRAME STRUCTURE . . . . .	APPENDIX B
PLOTTER CONFIGURATIONS . . . . .	APPENDIX C
SELF TEST . . . . .	APPENDIX D
OPERATIONAL TROUBLESHOOTING . . . . .	APPENDIX E
DIGITAL RECEIVER DATA OUTPUT . . . . .	APPENDIX F
CODED SELECTABLE FILTERS . . . . .	APPENDIX G
ERROR CODES . . . . .	APPENDIX H





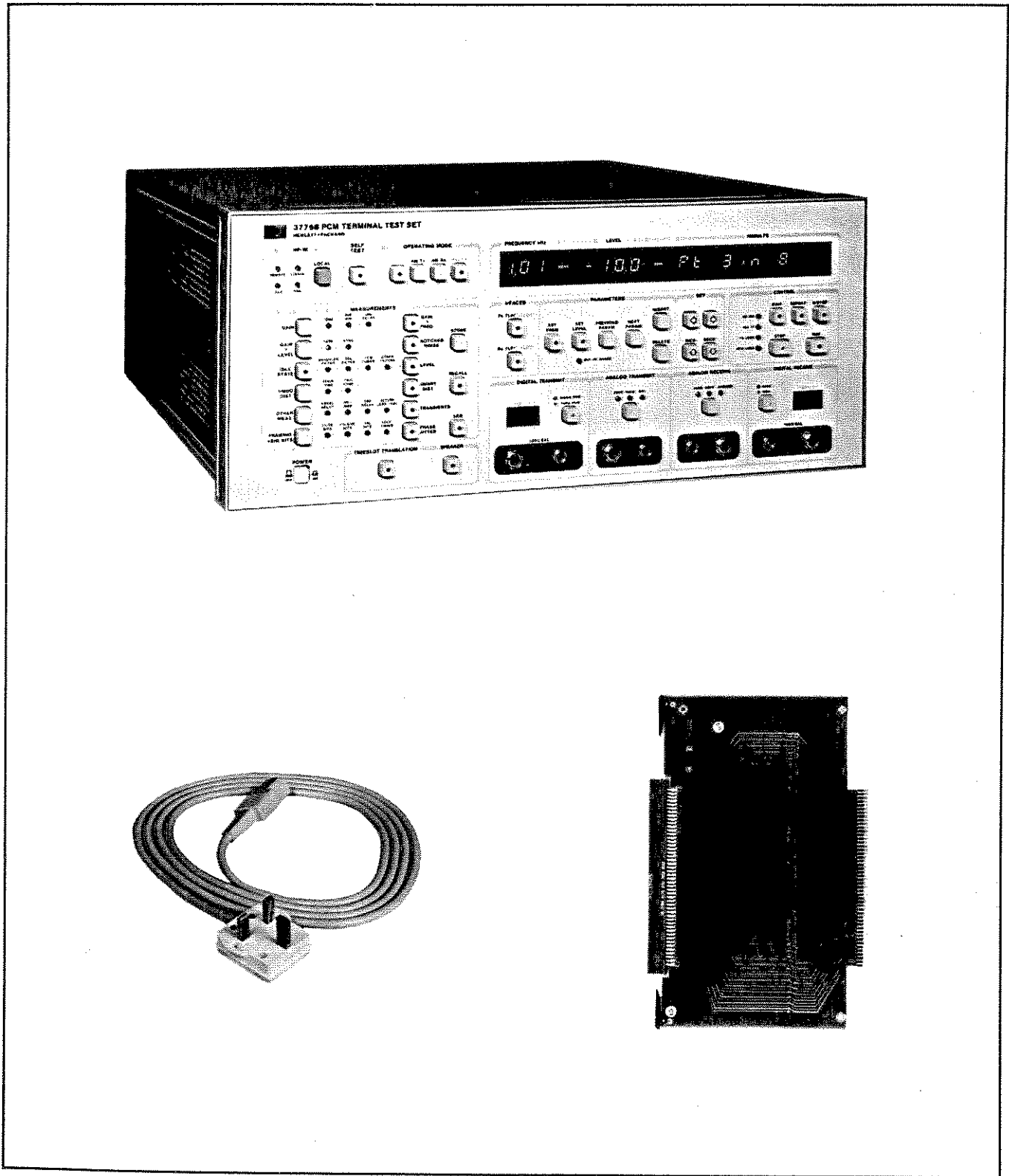

Figure 1-1 The 3776B PCM Terminal Test Set with Accessories supplied



## SECTION I GENERAL INFORMATION

### 1-1 INTRODUCTION

1-2 This Operating Manual contains information required to install and operate the Hewlett-Packard Model 3776A and 3776B PCM Terminal Test Set. A PCM Terminal Test Set together with the power cable and extender board supplied are shown in Figure 1-1.

1-3 The Operating instructions in this manual cover both manual and HP-IB (Hewlett-Packard Interface Bus) operation. Operating instructions are supplied in the OPERATORS GUIDE.

1-4 On the title page of this manual is a Microfiche Part Number. This number can be used to order 4 x 6 inch microfilm transparencies of the manual. Each microfiche contains up to 96 photo duplicates of the manual pages.

### 1-5 SPECIFICATION

1-6 Instrument specifications are listed in Table 1-3. These specifications are the performance standards or limits against which the instrument is tested. Table 1-2 (page 1-5) is a tabular index to facilitate location of individual measurement specifications within Table 1-3.

### 1-7 SAFETY CONSIDERATION

1-8 This product is a Safety Class 1 instrument (provided with a protective earth terminal). The instrument and manual should be reviewed for safety markings and instructions before operation. Also read the Warning on Page 2.

### 1-9 INSTRUMENTS COVERED BY MANUAL

1-10 Attached to the instrument is a serial number plate. This serial number is in the form XXXXUXXXXX. It is in two parts; the first four digits and the letter are the serial prefix and the last five are the suffix. The prefix is the same for all identical instruments, it changes only when a change is made to the instrument. The suffix however, is assigned sequentially and is different for each instrument. The contents of this manual apply to instruments with the serial number prefix(es) listed under SERIAL NUMBERS on the title page.

1-11 An instrument manufactured after the printing of this manual may have a serial number prefix that is not listed on the title page. This unlisted serial number prefix indicates the instrument is different from those described in this manual. The manual for this new instrument is accompanied by a Manual Changes supplement. This supplement contains "change information" that explains how to adapt the manual to the newer instrument.

1-12 In addition to change information, the supplement may contain information for correcting errors in the manual. To keep this manual as current and accurate as possible, Hewlett-Packard recommends that you periodically request the latest Manual Changes supplement. The supplement for this manual is identified with the manual print data and part number, both of which appear on the manual title page. Complimentary copies of the supplement are available from Hewlett-Packard.

1-13 For information concerning a serial number prefix that is not listed on the title page or in the Manual Changes supplement, contact your nearest Hewlett-Packard office.

1-14 DESCRIPTION

1-15 The 3776A and 3776B PCM Terminal Test Sets make comprehensive voice and data measurements on 4kHz bandwidth, analog and digital channels. Besides testing PCM multiplexers and channel banks, these instruments also provide powerful facilities for testing transmultiplexers and digital switching systems. Both versions of HP's Terminal Test Set are fully programmable from an external controller via the HP-IB.

1-16 The 3776A fulfils the measurement needs of CEPT/CCITT transmission networks while the 3776B covers North American/Bell and Japanese systems.

1-17 HP's PCM Terminal Test Sets perform the measurements needed for both analog and digital testing on 4kHz channels. They replace the collection of independent analog and digital test equipment previously used in a mixed system environment with one test set. A summary of the measurements available is given in Table 1-1.

Table 1-1 Summary of Measurements Available

Standard Measurements	A-A	A-D	D-A	D-D	AN	DIG	DIG	AN
					Tx	Tx	Rx	Rx
Gain	*	*	*	*	*	*	*	*
Digital mW gain			*	*		*	*	*
Level (including harmonic distortion)	*	*	*	*	*	*	*	*
Gain v level (using tone)	*	*	*	*	*	*	*	*
Gain v level (using noise - 3776A)	*	*	*	*	*	*	*	*
Gain v level (using sync 2kHz)			*	*		*	*	*
Gain v frequency	*	*	*	*	*	*	*	*
Idle state (choice of filters)	*	*	*	*	*	*	*	*
Coder offset and peak codes		*		*	*	*	*	
Noise with tone	*	*	*	*	*	*	*	*
Quantizing distortion (using tone)	*	*	*	*	*	*	*	*
Quantizing distortion (using noise - 3776A)	*	*	*	*	*	*	*	*
Intermodulation (using two tones)	*	*	*	*	*	*	*	*
Intermodulation (using four tones - 3776B)	*	*	*	*	*	*	*	*
Digital Tx/Rx				*		*	*	
Return loss 4W (ERL - 3776B)	*	*	*	*	*	*	*	*
Loop timing (selected by using the OTHER MEAS key)				*				
Option 001 Measurements								
Group delay distortion (3776A)	*	*	*	*	*	*	*	*
Envelope delay distortion	*	*	*	*				
Absolute delay	*	*	*	*				
Phase jitter (choice of filters)	*	*	*	*	*	*	*	*
Re-modulation	*	*						
Transients: (Amplitude/gain hits	*	*	*	*	*	*	*	
Phase hits								
Interruptions/dropouts								
Impulse noise)								

1-18 The main features incorporated into the 3776A and 3776B are listed as follows:

- Pre-programmed measurement default parameters
- User-modified measurement parameters held in non-volatile memory
- Automatic validity checks carried out on parameter entries
- Measurement sequences can be loaded into non-volatile memory from an external controller
- Once entered, measurement sequences can be run with or without an external controller
- Hard-copy measurement parameters results output via HP-IB without an external controller

1-19 The 3776A can be used to set and to monitor the PCM stream's framing and signalling bits, ie frame word, non-frame word, TS16 frame 0 and TS16 signalling bits. When control of the frame word is selected, simulated error ratio, frame alignment, AIS and loss of 2.048Mb/s signal parameters can be inserted into the transmitter's output stream for checking alarms in the PCM multiplex.

1-20 The 3776B provides the capability to set and to monitor the PCM stream's  $F_T$ ,  $F_S$  and signalling bits. It can also generate a DS-1 (Extended Framing Format Fe) digital stream containing any framing and signalling bits set by the user. This checks channel bank alignment and alarms. A looped timing check is also available and this indicates whether or not a remote channel bank is loop-timed, in addition to detecting the presence of timing jitter on the line.

**1-21 ACCESSORIES SUPPLIED**

1-22 Figure 1-1 shows the HP Model 3776 together with the power cable and extender board supplied.

a) The line power cable is supplied in one of six configurations depending upon the country of destination of the instrument (see INSTALLATION, SECTION II).

b) The following manuals are also supplied with each instrument:

- Service Manual (combined 3776A/B manual)
- Operating Manual (separate 3776A and 3776B manual)
- Operating Booklet (separate 3776A and 3776B booklet)

**1-23 EQUIPMENT AVAILABLE**

1-24 A Loop Holding Accessory is available for use with either the 3776A or 3776B. There are three Loop Holding Accessories and their model numbers are listed here:

- HP 15518A available with 3776A only
- HP 15518B available with 3776B only
- HP 15518C available with 3776B fitted with Japanese option

1-25 A Channel Selector, printer, plotter and external controller may also be used with this instrument. A typical example of each is listed here:

HP 3777A.....	Channel Selector
HP 85.....	Controller
HP 2631B.....	80 Column Printer
HP 7470A.....	HP-GL Plotter

1-26 Two sets of cables are available with 3776B Option 004, viz:

- HP 15567A (450mm).....cable assy (D/D)
- HP 15568A (260mm).....cable assy (A/A)

**1-27 OPTIONS**

1-28 The following options are available and are covered by this manual:

	3776A	3776B
OPTION 001	<p>Adds the following data measurements;</p> <p>group delay distortion                      envelope delay distortion                      absolute delay                      phase jitter                      transients of amplitude hits,                      phase hits, interruptions and                      3 level impulse noise.                      Also adds rear panel MONITOR O/P.</p>	<p>Add the following data measurements;</p> <p>envelope delay distortion                      remodulation                      absolute delay                      phase jitter                      transients of gain hits, phase                      hits, dropouts and 3 level                      impulse noise.                      Also adds rear panel MONITOR O/P.</p>
OPTION 002	<p>Replaces front panel BNC connectors with Siemens 75ohms UNBALANCED coaxial (1.6mm/5.6mm) connector.</p>	<p>Japanese option requirements same as standard 3776B except for the following:</p> <p>a) Psophometric weighted filter in place of C-message.                      b) 810Hz default test frequency instead of 1010Hz.                      c) Front panel connectors replaced by Japanese I-214 type BALANCED connector.</p>
OPTION 004		<p>Front panel connectors change to TROMPETER and mounted on rear panel.</p>
OPTION 801	<p>Front cover including foam insert to hold Loop Holding Accessory.</p>	<p>Front cover including foam insert to hold Loop Holding Accessory.</p>

Table 1-2 Index to Specifications in Table 1-3

A/B/ OPT	MEASUREMENT	SPECIFICATION/PAGE NUMBER							
		A-A	A-D	D-A	D-D	AN Tx	DIG Tx	AN Rx	DIG Rx
A & B	GAIN (Tone)	1-19	1-25	1-32	1-37	1-42	1-46	1-50	1-53
	GAIN (Digital MW)			1-32	1-37		1-46	1-50	1-53
	GAIN (Digital Tx-Rx)				1-37		1-46		1-53
	GAIN V FREQUENCY	1-19	1-25	1-32	1-37	1-42	1-46	1-50	1-53
A	GAIN V LEVEL (Using Noise)	1-19	1-25	1-32	1-38	1-42	1-46	1-50	1-53
A & B	GAIN V LEVEL (Using Tone)	1-19	1-26	1-33	1-38	1-43	1-47	1-50	1-53
	GAIN V LEVEL (Synchronising 2kHz)			1-33	1-39		1-47	1-51	1-54
	NOISE WITH TONE	1-20	1-26	1-34	1-39	1-43	1-47	1-51	1-54
	IDLE STATE					1-43	1-48		
	IDLE STATE (Weighted, Selective, Other Filters)	1-20	1-27	1-34	1-39			1-51	1-54
	IDLE STATE (PCM Codes)		1-27		1-39				1-54
	LEVEL					1-44	1-48		
	LEVEL (Weighted, Other Filters)	1-21	1-27						
	LEVEL (Selective)	1-22	1-28						
	LEVEL (Weighted, Selective, Other Filters)			1-34	1-40			1-51	1-54
LEVEL (PCM Codes)		1-29		1-40				1-54	
A	QUANTISING DISTORTION (Using Noise)	1-22	1-29	1-35	1-40	1-44	1-48	1-51	1-55
A & B	QUANTISING DISTORTION (Using Tone)	1-23	1-30	1-35	1-40	1-44	1-48	1-52	1-55
	INTERMODULATION (2-Tone)	1-23	1-30	1-36	1-41	1-45	1-48	1-52	1-55
B	INTERMODULATION (4-Tone)	1-23	1-31	1-36	1-41	1-45	1-49	1-52	1-56
	RETURN LOSS (ERL)	1-24	1-31	1-36	1-41	1-45	1-49	1-52	1-56
A	GROUP DELAY					1-58	1-60	1-59	1-60
A & B	ABSOLUTE DELAY					1-60	1-61	1-61	1-61
	ENVELOPE DELAY					1-61	1-62	1-62	1-62
B	RE-MODULATION					1-63		1-63	1-63
A & B	PHASE JITTER					1-63	1-64	1-63	1-64
	TRANSIENTS					1-65	1-67	1-65	1-67
	(A) GAIN HITS							1-65	1-67
	(B) PHASE HITS							1-66	1-68
A	(C) INTERRUPTIONS							1-66	1-68
B	(D) DROPOUTS							1-66	1-68
A & B	(E) IMPULSE NOISE							1-66	1-68

ADDITIONAL ITEMS FOR OPT 001 ONLY

Table 1-3 Hardware and Measurement Specifications

Except where otherwise indicated, the following parameters are warranted performance specifications. Parameters described as "typical" or "nominal" are supplemental characteristics which provide a useful indication of typical, but non-warranted, performance characteristics.

### HARDWARE SPECIFICATIONS

#### 1. ANALOG TRANSMITTER

##### SIGNALS

##### Sinewave

Frequency range: 200 to 3900Hz (50 to 4600Hz for level  
 Frequency accuracy: 50ppm (measurements)  
 Frequency resolution: 10Hz  
 Harmonics, spurious signals: >65dB down  
 (for output levels >-40dBm)

##### Two Tone

Frequency range  $f_A$  and  $f_B$ : 200 to 3900Hz  
 Frequency accuracy: 50ppm  
 Frequency resolution: 10Hz  
 Relative amplitude ( $f_A$  relative to  $f_B$ ): +/-0.1dB  
 Harmonics, spurious signals: >65dB down  
 (for output levels >-40dBm)

##### Noise

##### 3776A only

Meets CCITT Rec. 0.131  
 Amplitude distribution: gaussian nominal  
 Frequency distribution (3dB points): 375 to 525Hz nominal  
 Spectral line spacing: 3.9Hz  
 Crest Factor: 10.5 +/-0.5dB nominal  
 Repetition rate: 256ms +/-50ppm

##### Four Tone

##### 3776B only

Meets BSTR Pub. 41009  
 Lower tones centre frequencies: 860Hz +/-50ppm  
 Lower tones separation: 6Hz +/-1Hz  
 Upper tones centre frequencies: 1380Hz +/-50ppm  
 Upper tones separation: 16Hz +/-1Hz  
 Relative level of four tones: +/-0.1dB  
 Harmonic distribution: <-35dB  
 Spurious signals 1877 to 1923Hz: <-70dB  
                   503 to 537Hz: <-70dB  
                   2223 to 2257Hz: <-70dB



**Echo Return Loss (ERL)**  
3776B only

Meets BSTR pub. 41009

**Group Delay**  
3776A option 001 only

Reference frequency range: 500 to 3000Hz  
 Measurement frequency range: 200 to 3600Hz  
 Modulation method and measurement: conforms to CCITT  
 Rec. 0.81

**Envelope Delay**  
(option 001 only)

- A Modulation frequency: 41 2/3Hz +/-50ppm  
 Modulation depth: 0.40 +/-0.05  
 Carrier frequency range: 300 to 3500Hz
- B Meets BSTR Pub. 41009  
 Modulation frequency: 83 1/3Hz +/-50ppm  
 Carrier frequency range: 300 to 3500Hz

**Absolute Delay**  
(option 001 only)

Same as envelope delay

**LEVEL**  
Maximum Output Level

sinewave: +10dBm  
 two tone: +7dBm  
 noise (3776A only): +2dBm  
 four tone (3776B only): +4dBm  
 echo return loss (3776B only): 0dBm  
 group delay (3776A option 001 only): +5dBm  
 envelope delay (option 001 only): +5dBm

**Minimum Output level**

-76.5dBm nominal  
 Level resolution: 0.1dB nominal  
 Transmit dBr (TLP) range: -20 to +10dB  
 Level accuracy: (includes return loss effects)

Nominal Signal Level (dBm)	Accuracy (+/-dB)
>-30	0.09
>-60	0.11
>-76	0.13

**Level Flatness**

50 to 200Hz: +/-0.3dB  
 200 to 3900Hz: +/-0.04dB

**OUTPUT**

Max dc isolation: +/-56V  
 Impedance: selectable 600ohm/900ohm nominal,  
 balanced/unbalanced  
 Connectors: 3776A - Siemens 3-pin  
 3776B - WECO 310 and Bantam jack

**2. ANALOG RECEIVER****INPUT**

Noise floor: <-100dBmp (<-10dBrnC)  
 Maximum continuous ac signal level: 9V p-p  
 Maximum continuous dc signal level: +/-56V  
 Input flatness (200 to 3900Hz): +/-0.03dB  
 Receiver dBr (TLP) range: -20 to +10dB  
 Impedance: selectable 600ohm/900ohm/50kohm, nominal  
 Connectors: 3776A - Siemens 3-pin  
 3776B - WECO 310 and Bantam jack

**FILTERS**

The following filters are provided and are selected as appropriate by the measurement software:

Selective: 85Hz nominal noise bandwidth over frequency range 200 to 3900Hz  
 3kHz flat: meets BSTR Pub. 41009  
 Wideband: flat filter with dc rejection  
 4100Hz high pass: filter used for out-of-band measurements

**Filters used in 3776A only:**

Quantising distortion reference and measurement: meets CCITT Rec. 0.13  
 Psophometric\*: meets CCITT Rec. P53A  
 810Hz notch\*: meets CCITT Rec. 0.132

\*These filters are also used in 3776B Option 002 (Japanese)

**Filters used in 3776B only:-**

Four-tone intermodulation: meets BSTR Pub. 41009  
 C-message: meets IEEE P743/D3\*  
 C-message notch: meets IEEE P743/D3\*  
 200Hz high pass: filter used for echo return loss (ERL)

\*Not used in 3776B option 002.

Filters used when option 001 is fitted:-

Impulse noise:

3776A - selectable three notched band-pass filters to CCITT Rec. 0.71

3776B - C-notched filter to IEEE P743/D3

Phase jitter: selectable as

Fil A - 30 to 300Hz

Fil B - 4 to 300Hz

### 3. DIGITAL TRANSMITTER

#### SIGNALS

As analog transmitter except bandwidth limited to 200 to 3600Hz

#### LEVEL

##### Maximum Output Level

sinewave: +3.1dBm0

two tone: 0.0dBm0

noise (3776A only): -5.0dBm0

four tone (3776B only): -3.0dBm0

echo return loss (3776B only): -7.0dBm0

group delay (3776A Option 001 only): -2.0dBm0

envelope delay (Option 001 only): -2.0dBm0

##### Minimum output level:

-60.0dBm0 nominal

Level resolution: 0.1dBm0 nominal

Level accuracy:

Nominal Signal Level (dBm0)	A-law	u-law
>-40	0.01	0.01
>-55	0.03	0.03
>-60	0.03	0.05

#### TEST CHANNEL OR TIMESLOT

Insertion of test signals into one selectable timeslot, all timeslots or all timeslots except one in the PCM stream.

## FRAMING & SIGNALLING BITS MANIPULATION

Selectable bit patterns of:-

- 3776A - timeslot 0 in frame 0; timeslot 0 in non-frame 0;  
timeslot 16 in frame 0; timeslot 16 signalling bits in all other frames
- 3776B (FT frame format) - FT bits, FS bits, signalling A & B bits
- (FE frame format) - FE bits, signalling ABCD bits

## SIMULATION OF TERMINAL ALARMS (3776A only)

Timeslot 0 in frames containing alignment word  
Error Ratio -  $1 \times 10^{-5}$ ,  $5 \times 10^{-5}$ ,  $1 \times 10^{-4}$ ,  $5 \times 10^{-4}$ ,  $1 \times 10^{-3}$   
can be simulated in the frame alignment word  
Frame alignment - 1 in 2, 2 in 4, 3 in 4 frame alignment word in  
error can be simulated in the PCM stream  
AIS - an all ones signal can be inserted in PCM stream  
OFF - no 2048kb/s PCM stream signal

Timeslot 0 in non-frames containing alignment word  
Frame alignment - 1 in 2 or 3 in 4 of bit 3 in error can be  
simulated in the PCM stream

## UNSELECTED AUDIO TIMESLOTS

THRU PCM: as received from digital receiver  
SYNTH PCM: background signal  
(Two user programmable PCM codes alternating at 1kHz.  
The two PCM codes are accessible via the Digital Tx-Rx measurement  
on the front panel.)

## PCM OUTPUT

Frame format:

- 3776A - conforms to CCITT Rec. G.732. Rear panel switch selects 30  
or 31 audio channels (timeslot 16 is used as an audio channel)
- 3776B - rear panel switch selects
  - FT - standard frame format conforming to BSTR Pub. 43801  
(CCITT Rec. G.733)
  - or FE - extended superframe (ESF) format conforming to AT & T  
Technical Advisory No. 70

Frame source: Synthesized from internal source or looped through  
from digital receiver

Compression characteristics: conforms to CCITT Rec. G.711  
3776A - A-law with alternate digit inversion (ADI), ideal  
3776B - U-law, ideal

Signalling: rear panel switch selects channel associated signalling  
(CAS) or common channel signalling (CCS)

**Coding:**

- 3776A - rear panel switch selects HDB3 or AMI
- 3776B - rear panel switch selects AMI (AZS) or B8ZS

**Impedance:**

- 3776A - 120ohm balanced nominal and 75ohm unbalanced nominal
- 3776B - 100ohm balanced nominal

**Connectors:**

- 3776A - Siemens 3-pin (balanced); BNC (unbalanced)
- 3776B - WECD 310 and Bantam jack

**Amplitude:**

	3776A, 3776B balanced outputs	3776A unbalanced output
Mark	+/-3V +/-10%	+/-2.37V +/-10%
Space	+/-0.3V max	+/-0.24V max

- Overshoot: <10% amplitude
- Width (at 50% amplitude): 50% +/-6%
- Transition times: <30ns

**CLOCKS**

**Internal**

- Frequency: 3776A - 2048kHz +/-50ppm
- 3776B - 1544kHz +/-50ppm

**External**

- Frequency: internal bit rate
- Level: TTL into 75ohm, nominal
- Connector: BNC

**4. DIGITAL RECEIVER**

**TEST CHANNEL**

Selected timeslot in the PCM stream

**PCM INPUT**

**Frame format:**

- 3776A - meeting CCITT Rec. G.732
- 3776B - meeting BSTR Pub. 43801 (CCITT Rec. 733) if FT selected
- meeting AT+T Technical Advisory Note No. 70 if FE selected

Expansion characteristics: conforms to CCITT Rec. G.711

- 3776A - A-law ideal
- 3776B - u-law ideal

Frame alignment: automatic

Multi-frame alignment: automatic if CAS selected

Signalling: selectable as CAS or CCS

Coding:

3776A - selectable HDB3 or AMI

3776B - selectable AMI (AZS) or B8ZS

Impedance:

3776A - 120ohm balanced nominal; 75ohm unbalanced nominal

3776B - 100ohm balanced nominal

Connector:

3776A - Siemens 3-pin (balanced); BNC (unbalanced)

3776B - WECO 310 and Bantam jack

Maximum input level: +/-8V

Minimum input levels (equivalent cable loss):

3776A - 6dB at 1MHz

3776B - 6dB at 0.75MHz

Modes: selectable as

TERMinated - PCM input terminated by characteristic impedance

MONitor

3776A - provides 30dB gain      PCM input terminated by

3776B - provides 20dB gain      characteristic impedance

LED status indicators:

no signal - >15 consecutive zeros or signal level too low

all ones - >4096 consecutive ones

frame alignment loss

3776A - complies with CCITT Rec. G.732

3776B - 3 out of 7 FT bits in error

multi-frame alignment loss

3776A - complies with CCITT Rec. G.732

3776B - 2 consecutive FS bits in error

## FRAMING & SIGNALLING BITS MONITORING

Bit pattern monitoring of

3776A - timeslot 0 in frame 0; timeslot 0 in non-frame 0;

timeslot 16 in frame 0; timeslot 16 signalling bits in all other frames

3776B (FT frame format) - FT bits, FS bits, signalling A&B bits

(FE frame format) - FE bits, CRC bits, signalling ABCD bits

## FILTERS

As analog receiver up to channel bandwidth of 3600Hz

**CLOCK**

Clock recovered from PCM input.  
 Frequency: 3776A - 2048kHz nominal  
 3776B - 1544kHz nominal  
 Max number of consecutive zeros: 15

**DIGITAL TTL OUTPUT: (rear panel)**

Received PCM bit pattern available as a serial output  
 Format: Low true  
 Signal levels: TTL, open collector  
 Receiver timing outputs: framing synchronisation; multi-frame  
 synchronisation; clock; selected data valid  
 Connector: Cannon 15 way

**TIMESLOT TRANSLATION**

3776A - contents of TS (n) and TS (16+n) exchanged  
 3776B - contents of TS (n) and TS (n+1) exchanged for all timeslots,  
 where n is odd

**AUXILIARY ANALOG INPUT: (rear panel)**

An external level source can be applied for retransmission from the analog or digital transmitter.

Impedance: 600ohm balanced  
 Connector: binding posts  
 Additional parameters:

Analog transmitter only  
 Additional flatness to internal source: +/-0.2dB nominal over 200 to 3600Hz

Digital transmitter only  
 Aux input dBr (TLP): -14dB (3776A)  
 -16dB (3776B)

Aux input flatness (nominal):

Frequency (Hz)	Accuracy (dB)
>200 to <300	+0.15, -2
>300 to <3000	+/-0.2
>3000 to <3300	+0.1, -0.4

**ANALOG MONITOR OUTPUT option 001 only: (rear panel)**

Analog output of the received analog or digital input after filtering.  
 Impedance: 600ohm balanced  
 Connector: binding posts

**SPEAKER**

Simple amplified loudspeaker output of analog input or selected timeslot decoded to allow channel monitoring/talk over channel.

**HP-IB: (rear panel)**

Flags: Remote, Listen, Talk, and Service Request

Implementation: (IEEE 488, 1978)

SH1 (complete capability)

AH1 (complete capability)

T5 (basic talker, serial poll, talk only mode, unaddress if MLA)

L4 (basic listener, unaddress if MTA)

SR1 (complete SRQ capability)

RL1 (complete remote-local capability)

DC1 (complete device clear capability)

The IEEE 728 codes and formats capabilities are ...

**PM2 (program messages as Fig 24 and 25(b) in IEEE 728)**

NRD1 (implicit point numeric data)

NRD2 (fixed point numeric data)

NRD3 (floating point numeric data)

CHDF (character data field)

BDFA (binary block data, length specified, no check)

BDFI (binary block data, length unspecified, no check)

BDFH (hexadecimal data)

, (comma parameter separator)

; (semicolon command separator)

CRLE (CRLE command string terminator)

NL (NL command string terminator)

END (EOI command string terminator)

**M41 (measurement messages as Fig 21(a) and 21(b) in IEEE 728)**

NRD1 (implicit point numeric data)

NRD2 (fixed point numeric data)

BDFA (binary block data, length specified, no check)

, (comma data separator)

CRLE (CRLE data list separator)

END (EOI data list terminator)

Modes: selectable as

'addressable' - when an external controller is connected

'talk-only' - when no external controller is connected

Print format: (talk-only mode)

dual in line (DIL) switches select result output string to

'listen only' printer or plotter connected.

binary 2 - print output

binary 8 to 31 - plot option of various configurations



PLOT OPTIONS

Binary Format Number	Scale X Axis	Scale Y Axis	Auto Paper Eject	Plot Title and Axes	Plot CCITT Mask
8				yes	yes
9	yes			yes	yes
10		yes		yes	yes
11	yes	yes		yes	yes
12			yes	yes	yes
13	yes		yes	yes	yes
14		yes	yes	yes	yes
15	yes	yes	yes	yes	yes
16				yes	
17	yes			yes	
18		yes		yes	
19	yes	yes		yes	
20			yes	yes	
21	yes		yes	yes	
22		yes	yes	yes	
23	yes	yes	yes	yes	
24					
25	yes				
26		yes			
27	yes	yes			
28			yes		
29	yes		yes		
30		yes	yes		
31	yes	yes	yes		

Power on SRQ: selectable DIL switch

EOI: sets end or identify (EOI) with serial poll byte in addressable mode only; selectable DIL switch

Connector: Cannon 24 way

5. GENERAL

Supply voltages: 115V ac +10%, -22%  
 220V ac +10%, -22%

Power consumption: 85W nominal

Dimensions:

55178mm (7in) high  
 425mm (16.75in) wide  
 440mm (17.25in) deep

Weight: 15kg (33lb) nominal

Temperature range: operating 0degrees to 55degrees centigrade  
 storage -40degrees to 75degrees centigrade

## 6. OPTIONS

3776A  
Option 001

Adds data measurements of:  
group delay distortion  
envelope delay distortion  
absolute delay  
phase jitter  
transients\* of  
amplitude hits  
phase hits  
interruptions  
3-level impulse noise

3776B  
Option 001

Adds data measurements of:  
envelope delay distortion  
remodulation  
absolute delay  
phase jitter  
transients\* of  
gain hits  
phase hits  
dropouts  
3-level impulse noise

\*All four parameters in transients are measured simultaneously.

Option 002

Replaces front panel BNC connectors with Siemens 75ohm unbalanced coaxial (1.6mm/5.6mm) connectors

Option 002 - Japanese requirement same as standard instrument with the following exceptions:

- a) Psphometric weighting filter in place of C-message
- b) 810Hz default test frequency instead of 1010Hz
- c) Front panel connectors replaced with Japanese I-214 type balanced connectors

Option 004

Front panel analog & digital interface connectors on std. instrument located on rear panel.  
Connector: balanced triaxial trompeter type BJ77

## OTHER COMMON OPTIONS

Option 801

Front panel cover

Option 909

Rack flange & front handle combination kit

Option 907

Front handle kit

Option 910

Extra set of operating and service manuals.

Option 908

Rack flange kit

MEASUREMENT SPECIFICATIONS

GENERAL

In a PCM Channel, the apparent gain for tones varies with the phase of the signal at the start of the measurement. The size of the variation depends on the number (n) of independent values present in the sampled wave  $n = fs/h$ , where h is the highest common factor of the tone frequency (Hz) and fs = Sampling frequency = 8000 or 16000. This governs the choice of test tones; frequencies such as 800 or 1000Hz have few independent samples and large gain variations, while 810 or 1010Hz have  $n = 800$  give stable results.

The standard test frequencies in this instrument have >400 independent samples, and the specifications for A-D and D-A measurements include a corresponding allowance for gain variation with phase. The specifications for A-A measurements do not include this effect, which is present only on PCM Channels. Its magnitude may be formed from the following table:

Level (dBm0)	Gain Variation with Phase (+/-dB)		
	A-law	u-law CCS	u-law CAS
>-40	0.005	0.005	0.01
>-60	0.015	0.01	0.03
>-75	0.03	0.03	0.05

The A-A measurements affected are shown below:

A-A Measurement	Number of error contributions
Gain Quantising distortion (tone) Level	one
Gain v Frequency Gain v Level (tone) Intermodulation (2-tone)	two

**ERROR CONTRIBUTIONS**

Each measurement accuracy is calculated as the total sum of the worst case values of all the individual component specification that make up the measurement. Error contributions due to transmission impairments in the system under test (eg QD in Gain vs Level measurement) are not included. Attempting to measure a tone where the frequency is not tied to the 3776 transmitter will result in an error in the following measurements:

Measurement Affected	Maximum additional error (dB)	
	Frequency	Error
Gain (tone) Gain (digital mW) Gain vs Frequency Intermod (2-tone)	200-400Hz >400Hz	0.04dB +0.01dB/Hz 0.02dB +0.01dB/Hz
Level (selective) Idle State (selective)	200-400Hz >400Hz	0.01dB +0.01dB/Hz 0.01dB/Hz

(For <5Hz offset between actual and selected Rx frequencies).

**ANALOG-TO-ANALOG (A-A) MEASUREMENTS**

**GAIN (TONE)**

Accuracy: +/-0.05dB (Tx and Rx levels >-30dBm, 200Hz to 3900Hz)

**GAIN v FREQUENCY**

Accuracy: +/-0.10dB (Tx and Rx levels >-30dBm, 200Hz to 3900Hz)

**GAIN v LEVEL (USING NOISE) - 3776A ONLY**

Accuracy (+/-dB):

Tx level (dBm)	Rx level (dBm)		
	>-46	>-66	>-76
>-46	0.15		
>-66	0.18	0.20	
>-76		0.22	0.30

Tx and Rx reference level >-36dBm0

**GAIN v LEVEL (USING TONE)**

Accuracy (+/-dB):

Tx level (dBm)	Rx level (dBm)		
	>-40	>-60	>-76
>-40	0.12		
>-60	0.12	0.16	
>-70		0.18	
>-76		0.22	0.30

Tx and Rx reference level >-40dBm0

**NOISE WITH TONE**

Transmit signal

Frequency range:

3776A - 810 to 850Hz

3776B - 1010 to 1020Hz

Level accuracy: +/-0.10dB

(for Level >-30dBm)

Accuracy (+/-dB):

S+N/N Ratio (dB)	Accuracy (+/-dB)
<30	0.5
<40	0.6
<45	0.8

Rx noise level >-80dBm

**IDLE STATE (WEIGHTED, SELECTIVE OR OTHER FILTERS)**

Accuracy (+/-dB):

Filter Type	Rx Level (dBm)	
	>-40	>-80
Psophometric	0.3	0.5
C-message	0.3	0.5
Selective	0.2	0.3
other filters:		
Filter A: 3Hz	0.3	0.5
Filter B: flat	0.3	0.75
Filter C: high pass	0.3	0.75

Rx signal crest factor assumed <12

**LEVEL (WEIGHTED, OTHER FILTERS)**

**Internal Source**

Frequency range: 50 to 4600Hz

Accuracy (+/-dB):

Nominal Signal Level (dBm)	Signal Level Accuracy (+/-dB)	
	50-200Hz	200-4600Hz
>-30	0.20	0.09
>-60	-	0.11
>-76	-	0.13

**Auxiliary input**

Gain between aux input (50kohms nominal) & analog transmit (600ohm balanced): +/-0.5dB (nominal)

Frequency range: 50 to 4600Hz

**Receiver**

Accuracy (+/-dB):

Filter type	Rx Level (dBm)	
	>-40	>-80
Psophometric	0.3	0.5
C-Message	0.3	0.5
other filters:		
Filter A: 3kHz	0.3	0.5
Filter B: flat	0.3	0.75
Filter C: high pass	0.3	0.75

**LEVEL (SELECTIVE)**

Internal source: same as LEVEL (weighted)  
 Auxiliary input: same as LEVEL (weighted)

**Receiver**

Frequency range: 200 to 3900Hz  
 Accuracy (+/-dB):

a) Transmit (ref) frequency same as receive (measure) frequency

Receive level (dBm)	Receive Accuracy (+/-dB)
>-40	0.10
>-80	0.14

Rx level >-80dBm

b) Transmit (ref) frequency not the same as receive (measure) frequency

Ref/Meas Ratio (dB)	Receive Accuracy (+/-dB)
<40	0.7
<45	1.1

Rx level >-80dBm

**QUANTISING DISTORTION (USING NOISE) - 3776A ONLY**

Accuracy (+/-dB):

S/N Ratio (dB)	Rx distortion level (dBm)	
	>-72	>-76
<40	0.5	0.9
<45	1.0	1.2

Rx noise level >-66dBm



**QUANTISING DISTORTION (USING TONE)**

Transmit signal

Frequency range:

3776A - 810 to 850Hz  
 3776B - 1010 to 1020Hz

Accuracy (+/-dB):

S+N/N Ratio (dB)	Accuracy (+/-dB)
<30	0.3
<40	0.5
<45	0.8

Rx noise level >-80dBm

**INTERMODULATION (2 TONE)**

Frequency range of  $f_A$  and  $f_B$ : 200 to 3900Hz

Intermodulation product,  $f_p$  ( $2f_A - f_B$ ) frequency range: 200 to 3900Hz

Tones at  $|f_A - f_B|$ ,  $|f_p - f_A|$  and  $|f_p - f_B|$  >150Hz

Accuracy (+/-dB):

Tone $f_A$ /Tone $f_p$ (dB)	Accuracy (+/-dB)
<30	0.1
<40	0.2
<45	0.5

Rx level (tone A) >-36dBm

**INTERMODULATION (4 TONE) - 3776B ONLY**

Accuracy (+/-dB):

Measured intermodulation (dB)	Accuracy (+/-dB)
<45	0.5
<55	1.0

Rx stimulating signal >-30dBm

**RETURN LOSS (ERL) - 3776B ONLY**

**Tx level accuracy: +/-0.25dB**

(Tx levels >-30dBm)

**Rx accuracy:**

Rx signal level (dBm)	Accuracy (+/-dB)
>-40	0.3
>-80	0.5

**ANALOG-TO-DIGITAL (A-D) MEASUREMENTS**

**GAIN (TONE)**

Accuracy (+/-dB):

	Accuracy (+/-dB)
3776A; 3776B (CCS)	0.10
3776B (CAS)	0.11

Tx level >-30dBm; Rx level >-20dBm0  
800 independent samples

**GAIN v FREQUENCY**

Accuracy (+/-dB):

	Accuracy (+/-dB)
3776A; 3776B (CCS)	0.08
3776B (CAS)	0.11

Tx level >-30dBm; Rx level >-20dBm0  
800 independent samples

**GAIN v LEVEL (USING NOISE) - 3776A ONLY**

Accuracy (+/-dB):

Tx level (dBm)	Rx level (dBm0)		
	>-40	>-55	>-60
>-46	0.11	0.12	0.18
>-56	0.12	0.13	0.19
>-66	0.13	0.14	0.20
>-76	0.15	0.16	0.22
>-82	0.18	0.20	0.25

Tx reference level >-30dBm  
Rx reference level >-20dBm0

**GAIN v LEVEL (USING TONE)**

Frequency range: 200 to 3900Hz

Accuracy (+/-dB):

3776A and 3776B (CCS) -

Tx level (dBm)	Rx level (dBm0)		
	>-40	>-50	>-60
>-50	0.11	0.13	-
>-60	0.12	0.15	0.30
>-70	0.14	0.17	0.32
>-76	0.18	0.20	0.35

3776B (CAS) -

Tx level (dBm)	Rx level (dBm0)		
	>-40	>-50	>-60
>-50	0.12	0.15	-
>-60	0.14	0.20	0.35
>-70	0.16	0.22	0.37
>-76	0.20	0.25	0.40

Tx reference level >-30dBm; Rx reference level >-20dBm0

**NOISE WITH TONE**

Accuracy (+/-dB):

S+N/N Ratio (dB)	Accuracy (+/-dB)
<30	0.2
<40	0.4
<45	0.6

**Transmit Signal**

Frequency range:

3776A: 810 to 850Hz

3776B: 1010 to 1020Hz

Level accuracy: +/-0.10dB

(for level >-30dBm)

Rx noise level >-60dBm0

**IDLE STATE (WEIGHTED, SELECTIVE, OTHER FILTERS)**

Accuracy (+/-dB):

Filter type	Rx level (dBm0)	
	>-60	>-75
Psophometric	0.15	0.3
C-message	0.15	0.3
Selective	0.25	0.7
other filters:		
Filter A: 3kHz	0.15	0.7
Filter B: Flat	0.15	0.7

**IDLE STATE (PCM CODES)**

Transmitter: terminated with characteristic impedance

Receiver: detects average of 800 codes; result expressed as number of compressed code level steps from centre of coding law.

Signal range: bottom two segments of coding law

Resolution: +/-0.5 coded step

**LEVEL (WEIGHTED, OTHER FILTERS)**

Internal Source

Frequency range: 50 to 4600Hz

Accuracy (+/-dB):

Nominal Signal Level (dBm)	Signal Level Accuracy (+/-dB)	
	50-200Hz	200-4600Hz
>-30	0.2	0.09
>-60	-	0.11
>-76	-	0.13

**Auxiliary input**

Gain between aux input (50kohms nominal) & analog transmit (600ohms balanced): +/-0.5dB

Frequency range: 50 to 4600Hz

Accuracy (+/-dB):

Nominal Signal Level (dBm)	Signal Level Linearity (+/-dB)
>-30	0.25
>-60	0.28
>-76	0.30

**Receiver**

Accuracy (+/-dB):

Filter type	Rx Level (dBm0)	
	>-60	>-75
Psophometric	0.3	0.5
C-Message	0.3	0.5
other filters:		
Filter A: 3kHz	0.2	0.7
Filter B: flat	0.2	0.7

**LEVEL (SELECTIVE)**

**Transmitter**

Internal source same as LEVEL (weighted)

Auxiliary input

**Receiver**

Frequency range: 200 to 3900Hz

Accuracy (+/-dB):

- a) Transmit (ref) frequency same as receive (measure) frequency

Receive Level (dBm0)	Receive Accuracy (+/-dB)
>-40	0.1
>-60	0.25

- b) Transmit (ref) frequency not the same as receive (measure) frequency

Ref/Meas Ratio (dB)	Rx level (dBm0)	
	>-40	>-60
<40	0.12	0.3
<45	0.25	0.4

**LEVEL (PCM CODES)**

**Transmitter**

Internal source same as LEVEL (weighted)

Auxiliary input

**Receiver**

Detection: display the peak positive and peak negative PCM codes in 800 samples. Result expressed in compressed codes.

**QUANTISING DISTORTION (USING NOISE) - 3776A ONLY**

Accuracy (+/-dB):

S/N Ratio (dB)	Rx distortion level (dBm0) >-60
<40	0.3
<45	0.6

Rx noise level >-60dBm0

### QUANTISING DISTORTION (USING TONE)

#### Transmit signal

##### Frequency range:

3776A - 810 to 850Hz

3776B - 1010 to 1020Hz

##### Accuracy (+/-dB):

S+N/N Ratio (dB)	Accuracy (+/-dB)
<30	0.2
<40	0.4
<45	0.6

Rx tone level >-60dBm0

### INTERMODULATION (2 TONE)

Frequency range of  $f_A$  and  $f_B$ : 200 to 3900Hz

Intermodulation product  $f_p$  ( $2f_A - f_B$ ) frequency range: 200 to 3900Hz

Tones at  $|f_A - f_B|$ ,  $|f_p - f_A|$  and  $|f_p - f_B| > 150$ Hz

##### Accuracy (+/-dB):

Tone $f_A$ /Tone $f_p$ (dB)	Accuracy (+/-dB)
<30	0.2
<40	0.3
<45	0.5

Rx level (tone  $f_A$ ) >-20dBm0

Rx level (tone  $f_p$ ) >-50dBm0



**INTERMODULATION (4 TONE) - 3776B ONLY**

Accuracy (+/-dB):

Measured intermodulation (dB)	Accuracy (+/-dB)
<45	0.5
<55	1.0

Rx Stimulating signal >-20dBm0

Intermod Rx level >-50dBm0

**RETURN LOSS (ERL) - 3776B ONLY**

Tx level accuracy: +/-0.25dB

(Tx levels >-30dBm)

Rx accuracy: +/-0.3dB

(Rx levels >-60dBm)

**DIGITAL-TO-ANALOG (D-A) MEASUREMENT**

**GAIN (TONE)**

Frequency range: 200 to 3900Hz  
 Accuracy (+/-dB):

	Accuracy (+/-dB)
3776A; 3776B (CCS)	0.11
3776B (CAS)	0.12

Tx level >-20dBm0; Rx level >-30dBm

**GAIN (DIGITAL mW)**

Accuracy (+/-dB): 0.10

**GAIN v FREQUENCY**

Frequency range: 200 to 3900Hz  
 Accuracy (+/-dB):

	Accuracy (+/-dB)
3776A; 3776B (CCS)	0.10
3776B (CAS)	0.11

Tx level >-20dBm0; Rx level >-30dBm

**GAIN v LEVEL (USING NOISE) - 3776A ONLY**

Accuracy (+/-dB):

Tx level (dBm0)	Rx level (dBm)		
	>-46	>-66	>-82
>-40	0.10	0.15	-
>-55	0.12	0.16	-
>-60	-	0.16	0.20

Tx reference level >-20dBm0  
 Rx reference level >-48dBm

**GAIN v LEVEL (USING TONE)**

Frequency range: 200 to 3900Hz

Accuracy (+/-dB):

3776A and 3776B (CCS)

Tx Level (dBm0)	Rx Level (dBm)		
	>-40	>-60	>-76
>-40	0.08	0.12	-
>-55	-	0.15	0.20
>-60	-	0.17	0.22

3776B (CAS)

Tx level (dBm0)	Rx Level (dBm)		
	>-40	>-60	>-76
>-40	0.09	0.13	-
>-55	-	0.17	0.22
>-60	-	0.20	0.25

Tx reference level >-20dBm0; Rx reference level >-40dBm

**GAIN v LEVEL (SYNCHRONISED 2kHz)**

Tx PCM code levels: ideal

Frequency: 2kHz

Accuracy (+/-dB):

	Rx level (dBm)		
	>-40	>-60	>-76
3776A; 3776B (CCS)	0.05	0.10	0.20
3776B (CAS)	0.05	0.10	0.20

Rx reference level >-20dBm

**NOISE WITH TONE**

**Transmit Signal**

Frequency range:

3776A - 810 to 850Hz

3776B - 1010 to 1020Hz

Level accuracy: +/-0.01dB

(for levels >-40dBm0)

Accuracy (+/-dB):

S+N/N Ratio (dB)	Accuracy (+/-dB)
<-30	0.5
<-40	0.6
<-45	0.8

Rx noise level >-80dBm

**IDLE STATE (WEIGHTED, SELECTIVE, OTHER FILTERS)**

Accuracy (+/-dB): same as IDLE STATE (A-A)

**LEVEL (WEIGHTED, SELECTIVE, OTHER FILTERS)**

**Internal Source**

Frequency range: 50 to 3900Hz

Accuracy (+/-dB):

Nominal Signal Level (dBm0)	Signal Level Accuracy (+/-dB)
>-40	0.01
>-55	0.03
>-60	0.05

**Auxiliary input**

Aux input dBr (TLP):

-14dB (3776A)

-16dB (3776B)

Level accuracy: +/-0.5dB  
 Aux input flatness (nominal):

Frequency (Hz)	Accuracy (dB)
>200 to <300	+0.15, -2
>300 to <3000	+/-0.2
>3000 to <3300	+0.1, 0.4

**Receiver**

Accuracy (+/-dB): same as LEVEL (weighted) (A-A)

**QUANTISING DISTORTION (USING NOISE) - 3776A ONLY**

Accuracy (+/-dB):

S/N Ratio (dB)	Rx distortion level (dBm)	
	>-72	>-76
<-40	0.5	0.9
<-45	0.9	1.2

Rx noise levels >-68dBm

**QUANTISING DISTORTION (USING TONE)**

**Transmit signal**

Frequency range:

- 3776A - 810 to 850Hz
- 3776B - 1010 to 1020Hz

Accuracy (+/-dB):

S+N/N Ratio (dB)	Accuracy (+/-dB)
<-30	0.5
<-40	0.6
<-45	0.8

Rx noise level >-80dBm

**INTERMODULATION (2-TONE)**

Frequency range of  $f_A$  and  $f_B$ : 200 to 3900Hz  
 Intermodulation product,  $f_p$  ( $2f_A - f_B$ ) frequency range: 200 to 3900Hz  
 Tones at  $|f_A - f_B|$ ,  $|f_p - f_A|$  and  $|f_p - f_B| > 150\text{Hz}$

Accuracy (+/-dB):

Tone $f_A$ /Tone $f_p$ (dB)	Accuracy (+/-dB)
<30	0.1
<40	0.2
<45	0.5

Rx level (tone  $f_A$ )  $> -36\text{dBm}$

**INTERMODULATION (4 TONE) - 3776B ONLY**

Accuracy (+/-dB):

Measured intermodulation (dB)	Accuracy (+/-dB)
<45	0.5
<55	1.0

Rx stimulating signal  $> -36\text{dBm}$

**RETURN LOSS (ERL) - 3776B ONLY**

Tx level accuracy: +/-0.01dB  
 (Tx levels  $> -20\text{dBm0}$ )  
 Rx accuracy:

Rx Signal level (dBm)	Accuracy (+/-dB)
$> -40$	0.3
$> -80$	0.5

**DIGITAL-TO-DIGITAL (D-D) MEASUREMENTS**

**GAIN (TONE)**

Accuracy (+/-dB):

	Accuracy (+/-dB)
3776A; 3776B (CCS)	0.04
3776B (CAS)	0.05

Tx, Rx levels > -20dBm0  
800 independent samples

**GAIN (DIGITAL mW)**

Accuracy (+/-dB):

	Accuracy (+/-dB)
3776A; 3776B (CCS)	0.02
3776B (CAS)	0.03

Rx level > -20dBm0

**GAIN (DIGITAL Tx-Rx)**

Transmit signal: alternates two 8-bit PCM codes at 1kHz rate.  
Receiver: displays the positive peak and negative peak PCM codes.  
(3776B CAS signalling bits suppressed)

**GAIN v FREQUENCY**

Accuracy (+/-dB):

	Accuracy (+/-dB)
3776A; 3776B (CCS)	0.05
3776B (CAS)	0.08

Tx, Rx levels > -20dBm0; 800 independent samples.

**GAIN v LEVEL (USING NOISE) - 3776A ONLY**

Accuracy (+/-dB):

Tx level (dBm0)	Rx level (dBm0)		
	>-40	>-55	>-60
>-40	0.08	0.10	0.15
>-55	0.10	0.12	0.18
>-60	-	0.12	0.18

**GAIN v LEVEL (USING TONE)**

Frequency range: 200 to 3900Hz

Accuracy (+/-dB):

3776A and 3776B (CCS)

Tx level (dBm0)	Rx level (dBm0)		
	>-40	>-50	>-60
>-40	0.08	0.10	-
>-50	0.10	0.12	0.25
>-60	-	0.14	0.30

3776B (CAS)

Tx level (dBm0)	Tx level (dBm0)		
	>-40	>-50	>-60
>-40	0.10	0.12	-
>-50	0.14	0.16	0.35
>-60	-	0.13	0.35

Tx, Rx reference levels >-20dBm0



**GAIN v LEVEL (SYNCHRONIZED 2kHz)**

Tx PCM code levels: ideal  
 Frequency: 2kHz  
 Accuracy (+/-dB):

	Rx level (dBm0)		
	>-20	>-40	>-60
3776A; 3776B (CCS)	0.05	0.06	0.08
3776B (CAS)	0.08	0.08	0.10

Rx reference level >-20dBm0

**NOISE WITH TONE**

Transmit signal  
 Frequency range:  
 3776A - 810 to 850Hz  
 3776B - 1010 to 1020Hz  
 Level accuracy: +/-0.01dB  
 (for levels >-40dBm0)

Accuracy (+/-dB):

S+N/N Ratio (dB)	Accuracy (+/-dB)
<-30	0.2
<-40	0.4
<-45	0.6

Rx noise levels >-60dBm0

**IDLE STATE (WEIGHTED, SELECTIVE, OTHER FILTERS)**

Accuracy (+/-dB): same as IDLE STATE (A-D)

**IDLE STATE (PCM CODES)**

Transmitter: quiet background  
 Receiver: detects average of 800 codes; result expressed as number of compressed PCM code level steps from centre of coding law

Signal range: bottom two segments of coding law  
 Resolution: +/-0.5 coded step

**LEVEL (WEIGHTED, SELECTIVE, OTHER FILTERS)**

Internal source  
 Auxiliary input Tx level accuracy same as LEVEL (D-A)

Receiver accuracy (+/-dB): same as LEVEL (A-D)

**LEVEL (PCM CODES)**

Detects the peak positive and peak negative PCM codes in 800 samples.  
 Result expressed in compressed codes.

**QUANTISING DISTORTION (USING NOISE) - 3776A ONLY**

Accuracy (+/-dB):

S/N Ratio (dB)	Rx distortion level (dBm0) >-60
<-40	0.3
<-45	0.6

Rx noise levels >-60dBm0

**QUANTISING DISTORTION (USING TONE)**

Transmit signal

Frequency range:

3776A - 810 to 850Hz  
 3776B - 1010 to 1020Hz

Accuracy (+/-dB):

S+N/N Ratio	Accuracy (+/-dB)
<30	0.2
<40	0.4
<45	0.6

Rx tone level >-60dBm0

**INTERMODULATION (2 TONE)**

Frequency range of  $f_A$  and  $f_B$ : 200 to 3900Hz  
 Intermodulation product  $f_p$  ( $2f_A - f_B$ ) frequency range: 200 to 3900Hz  
 Tones at  $|f_A - f_B|$ ,  $|f_p - f_A|$  and  $|f_p - f_B| > 150\text{Hz}$

Accuracy (+/-dB):

Tone $f_A$ /Tone $f_p$ (dB)	Accuracy (+/-dB)
<30	0.2
<40	0.3
<45	0.5

Rx level (tone  $f_A$ ) > -20dBm0  
 Rx level (tone  $f_p$ ) > -50dBm0  
 800 independent samples

**INTERMODULATION (4-TONE) - 3776B ONLY**

Accuracy (+/-dB):

Measured intermodulation (dB)	Accuracy (+/-dB)
<45	0.5
<55	1.0

Rx stimulating signal > -20dBm0  
 Intermod Rx level > -50dBm0

**RETURN LOSS (ERL) - 3776B ONLY**

Tx level accuracy: +/-0.01dB  
 (Tx levels > -20dBm0)  
 Rx accuracy: +/-0.3dB  
 (Rx levels > -60dBm0)

**ANALOG TRANSMITTER (AN Tx) ONLY**

**GAIN (TONE)**

Frequency range: 200 to 3900Hz  
 Tx Level accuracy: +/-0.09dB

**GAIN v FREQUENCY**

Frequency range: 200 to 3900Hz  
 Tx level accuracy: +/-0.09dB  
 Tx level flatness: +/-0.04dB  
 (Tx levels >-30dBm)

**GAIN v LEVEL (USING NOISE) - 3776A ONLY**

Level accuracy:

Nominal Signal Level (dBm)	Signal Level Accuracy (+/-dB)
>-36	0.09
>-66	0.11
>-82	0.13

Level Linearity:

Nominal Signal Level (dBm)	Signal Level Linearity (+/-dB)
>-46	0.05
>-56	0.06
>-66	0.07
>-76	0.09
>-82	0.12

(Reference levels >-38dBm)

**GAIN v LEVEL (USING TONE)**

Frequency Range: 200 to 3900Hz

Level accuracy:

Nominal Signal Level (dBm)	Signal Level Accuracy (+/-dB)
>-30	0.09
>-60	0.11
>-76	0.13

Level linearity:

Nominal Signal Level (dBm)	Signal Level Linearity (+/-dB)
>-40	0.05
>-50	0.06
>-60	0.07
>-70	0.09
>-76	0.12

(Reference levels &gt;-30dBm)

**NOISE WITH TONE**

Tx frequency range:

3776A - 810 to 850Hz

3776B - 1010 to 1020Hz

Tx level accuracy: +/-0.10dB

(Tx levels &gt;-30dBm)

**IDLE STATE**

Tx: terminated with characteristic impedance  
(ie 600ohms/900ohms, balanced/unbalanced)

**LEVEL**

Frequency range: 50 to 4600Hz

Internal Source:

Nominal Signal Level (dBm)	Signal Level Accuracy (+/-dB)	
	50 to 200Hz	200 to 4600Hz
>-30	0.2	0.09
>-60	-	0.11
>-76	-	0.13

Auxiliary input:

Auxiliary input to analog Tx gain: +/-0.5dB (nominal)

**QUANTISING DISTORTION (USING NOISE) - 3776A ONLY**

Nominal Signal Level (dBm)	Signal Level Accuracy (+/-dB)
>-36	0.09
>-66	0.11
>-82	0.13

**QUANTISING DISTORTION (USING TONE)**

Frequency range:

3776A - 810 to 850Hz

3776B - 1010 to 1020Hz

Tx level accuracy: same as Level (internal source)  
as above

**INTERMODULATION (2 TONE)**

Tone  $f_A$ /Tone  $f_B$  level ratio:  $<0.1$ dB

Tx level accuracy:  $\pm 0.10$ dB

Tx spurious level:  $>65$ dB down

(Tx levels  $>-30$ dBm)

**INTERMODULATION (4 TONE) - 3776B ONLY**

Tx level accuracy:  $\pm 0.10$ dB

(Tx levels  $>-30$ dBm)

**RETURN LOSS (ERL) - 3776B ONLY**

Tx level accuracy:  $\pm 0.25$ dB

(Tx levels  $>-30$ dBm)

**DIGITAL TRANSMITTER (DIG Tx) ONLY**

**GAIN (TONE)**

Frequency range: 200 to 3900Hz  
 Tx level accuracy: +/-0.01dB

**GAIN (DIGITAL mW)**

Transmits fixed sequence of PCM codes as defined in CCITT Rec G711  
 Tx send level: ideal

**GAIN (DIGITAL Tx-Rx)**

Transmits two programmable PCM codes alternating at 1kHz rate  
 Tx send level: ideal

**GAIN v FREQUENCY**

Frequency range: 200 to 3900Hz  
 Tx level accuracy: +/-0.01dB  
 Tx level flatness: ideal  
 (Tx levels >-40dBm0)

**GAIN v LEVEL (USING NOISE) - 3776A ONLY**

Level accuracy:

Nominal Signal Level (dBm0)	Signal Level Accuracy (+/-dB)
>-55	0.01
>-60	0.03

Level Linearity:

Nominal Signal Level (dBm0)	Signal Level Linearity (+/-dB)
>-55	0.02
>-60	0.04

(Reference levels >-40dBm0)



**GAIN v LEVEL (USING TONE)**

Frequency range: 200 to 3900Hz

Level Accuracy:

Nominal Signal Level (dBm0)	Signal Level Accuracy (+/-dB)	
	3776A	3776B
>-40	0.01	0.01
>-55	0.01	0.03
>-60	0.03	0.05

Level linearity:

Nominal Signal Level (dBm0)	Signal Level Linearity (+/-dB)	
	3776A	3776B
>-40	0.02	0.02
>-55	0.02	0.04
>-60	0.04	0.06

(Reference levels >-40dBm0)

**GAIN v LEVEL (SYNCHRONISED 2kHz)**

Transmits sequence of PCM codes at 2kHz rate; level programmable

Tx send level: ideal

**NOISE WITH TONE**

Tx Frequency range:

3776A - 810 to 850Hz

3776B - 1010 to 1020Hz

Tx level accuracy: +/-0.01dB

(Tx levels >-40dBm0)

**IDLE STATE**

**Tx code:**

3776A - 11010101 [after alternate digit inversion (ADI)]

3776B - alternates 11111111 and 01111111 at 1kHz rate

**LEVEL**

**Frequency range:** 200 to 3900Hz

**Internal Source:**

Nominal Signal Level (dBm0)	Signal Level Accuracy (+/-dB)	
	3776A	3776B
>-40	0.01	0.01
>-55	0.03	0.03
>-60	0.03	0.05

**Auxiliary input:**

Same as LEVEL (D-A) measurement

**QUANTISING DISTORTION (USING NOISE) - 3776A ONLY**

Nominal Signal Level (dBm0)	Signal Level Accuracy (+/-dB)
>-40	0.01
>-60	0.03

**QUANTISING DISTORTION (USING TONE)**

**Tx frequency range:**

3776A - 810 to 850Hz

3776B - 1010 to 1020Hz

**Tx level accuracy:** same as LEVEL (internal source) as above

**INTERMODULATION (2 TONE)**

**Tone f<sub>A</sub>/Tone f<sub>B</sub> ratio:** ideal (0.0dB)

**Tx level accuracy:** +/-0.01dB

(Tone f<sub>A</sub> and tone f<sub>B</sub> >-20dBm0)

**INTERMODULATION (4 TONE) - 3776B ONLY**

**Tx level accuracy: +/-0.01dB**  
(Tx levels >-20dBm0)

**RETURN LOSS (ERL) - 3776B ONLY**

**Tx level accuracy: +/-0.01dB**  
(Tx levels >-20dBm0)

**ANALOG RECEIVER (AN Rx) ONLY**

**GAIN (TONE)**

Frequency range: 200 to 3900Hz  
 Accuracy: +/-0.10dB  
 (Rx level >-30dBm; assume perfect Tx level)

**GAIN (DIGITAL mW)**

Accuracy: +/-0.10dB  
 (Rx level >-30dBm; assume perfect Tx level)  
 As defined in CCITT REC G711

**GAIN v FREQUENCY**

Frequency range: 200 to 3900Hz  
 Accuracy: +/-0.08dB  
 (Rx level >-30dBm; assume perfect Tx level)

**GAIN v LEVEL (USING NOISE) - 3776A ONLY**

	Rx level (dBm)		
	>-46	>-66	>-82
Accuracy (+/-dB)	0.08	0.12	0.30

(Rx reference level >-28dBm; assume perfect Tx levels)

**GAIN v LEVEL (USING TONE)**

Frequency range: 200 to 3900Hz

	Rx level (dBm)		
	>-40	>-60	>-76
Accuracy (+/-dB)	0.06	0.10	0.18

(Rx reference level >-20dBm, assume perfect Tx levels)

**GAIN v LEVEL (SYNCHRONISED 2kHz)**

	Rx level (dBm)		
	>-40	>-60	>-76
Accuracy (+/-dB)	0.05	0.1	0.2

(Rx reference level >-20dBm; assume ideal Tx levels)

**NOISE WITH TONE**

S+N/N Ratio (dB)	Accuracy (+/-dB)
<30	0.5
<40	0.6
<45	0.8

(Rx noise levels >-80dBm)

**IDLE STATE (WEIGHTED, SELECTIVE, OTHER FILTERS)**

Rx accuracy: same as IDLE STATE (A-A)

**LEVEL (WEIGHTED, SELECTIVE, OTHER FILTERS)**

Rx accuracy: same as Level (A-A)

**QUANTISING DISTORTION (USING NOISE) - 3776A ONLY**

Accuracy (+/-dB):

S/N Ratio (dB)	Rx distortion level (dBm)	
	>-72	>-76
<40	0.5	0.9
<45	0.9	1.2

(Rx noise levels >-68dBm)

**QUANTISING DISTORTION (USING TONE)**

Accuracy (+/-dB):

S+N/N Ratio (dB)	Accuracy (+/-dB)
<30	0.5
<40	0.6
<45	0.8

(Rx noise levels >-80dBm)

**INTERMODULATION (2-TONE)**

Tones at  $|f_A - f_B|$ ,  $|f_p - f_A|$  and  $|f_p - f_B| > 150\text{Hz}$   
Accuracy (+/-dB):

Tone $f_A$ /Tone $f_p$ (dB)	Accuracy (+/-dB)
<30	0.1
<40	0.2
<45	0.5

(Rx level (tone A) <-36dBm)

**INTERMODULATION (4 TONE) - 3776B ONLY**

Accuracy (+/-dB):

Measured intermodulation (dB)	Accuracy (+/-dB)
<45	0.5
<55	1.0

(Rx stimulating signal >-36dBm)

**RETURN LOSS (ERL) - 3776B ONLY**

Rx accuracy (+/-dB):

Rx Signal Level (dBm)	Accuracy (+/-dB)
>-40	0.3
>-80	0.5

**DIGITAL RECEIVER (DIG Rx) ONLY**

**GAIN (TONE)  
GAIN (DIGITAL mW)**

	Accuracy (+/-dB)
3776A; 3776B (CCS)	0.03
3776B (CAS)	0.04

(Rx levels >-20dBm0; assume perfect Tx level; 800 independent samples)

**GAIN (DIGITAL Tx-Rx)**

Receiver: detects peak positive and peak negative PCM codes

**GAIN v FREQUENCY**

	Accuracy (+/-dB)
3776A; 3776B (CCS)	0.05
3776B (CAS)	0.07

(Rx levels >-20dBm0; assume perfect Tx level; 800 independent samples)

**GAIN v LEVEL (USING NOISE) - 3776A ONLY**

Accuracy (+/-dB):

Rx level (dBm0)	Accuracy (+/-dB)
>-40	0.07
>-55	0.08
>-60	0.13

(Rx reference level >-20dBm0; assume perfect Tx level)

**GAIN v LEVEL (USING TONE)**

Accuracy (+/-dB):

Rx Level (dBm0)	3776A	3776B (CCS)	3776B (CAS)
>-40	0.07	0.06	0.08
>-50	0.08	0.08	0.12
>-60	0.25	0.25	0.30

(Rx reference level >-20dBm0; assume perfect Tx level; 800 independent samples)

**GAIN v LEVEL (SYNCHRONISED 2kHz)**

Accuracy (+/-dB):

Rx Level (dBm0)	3776A	3776B (CCS)	3776B (CAS)
>-40	0.06	0.05	0.08
>-60	0.08	0.08	0.10

(Rx reference level &gt;-20dBm0; assume ideal Tx level)

**NOISE WITH TONE**

Accuracy (+/-dB):

S+N/N Ratio (dB)	Accuracy (+/-dB)
<30	0.2
<40	0.4
<45	0.6

(Rx noise levels &gt;-60dBm0)

**IDLE STATE (WEIGHTED, SELECTIVE, OTHER FILTERS)**

Rx accuracy: same as IDLE STATE (A-D)

**IDLE STATE (PCM CODES)**

Receiver: detects average of 800 codes; result expressed as number of compressed PCM code level steps from centre of coding law.

Signal range: bottom two segments of coding law

Resolution: +/-0.5 coded step

**LEVEL (WEIGHTED, SELECTIVE, OTHER FILTERS)**

Rx accuracy: same as LEVEL (A-D)

**LEVEL (PCM CODES)**Detects the peak positive and peak negative PCM codes in 800 samples.  
Result expressed in compressed codes.



**QUANTISING DISTORTION (USING NOISE) - 3776A ONLY**

Accuracy (+/-dB):

S/N Ratio (dB)	Rx distortion level (dBm0) >-60
<-40	0.3
<-45	0.6

(Rx noise levels >-60dBm0)

**QUANTISING DISTORTION (USING TONE)**

Accuracy (+/-dB):

S+N/N Ratio (dB)	Accuracy (+/-dB)
<30	0.2
<40	0.4
<45	0.6

(Rx noise levels >-60dBm0)

**INTERMODULATION (2 TONE)**

Tones at  $|f_A - f_B|$ ,  $|f_p - f_A|$  and  $|f_p - f_B| > 150\text{Hz}$

Accuracy (+/-dB)

Tone $f_A$ /Tone $f_p$ (dB)	Accuracy (+/-dB)
<30	0.2
<40	0.3
<45	0.5

[Rx (tone A) >-20dBm0; Rx (tone fp) >-50dBm0; assume perfect Tx levels; assume Tx spurious <-60dB; 800 independent samples]

**INTERMODULATION (4 TONE) - 3776B ONLY**

Accuracy (+/-dB):

Measured intermodulation (dB)	Accuracy (+/-dB)
45	0.5
55	1.0

(Rx level &gt;-20dBm0; intermod Rx level &gt;-50dBm0)

**RETURN LOSS (ERL) - 3776B ONLY**

Accuracy: +/-0.3dB

(Rx levels &gt;-60dBm0).

**MEASUREMENT SPECIFICATIONS  
OPTION 001**

The specifications on pages 1-58 to 1-69 apply only to Models 3776A and 3776B fitted with Option 001.

**MEASUREMENT SPECIFICATIONS  
OPTION 001**

The following specifications apply only to the 3776A/B PCM Terminal Test Set with Option 001 fitted. Option 001 provides measurements of:

**3776A**

Group delay distortion  
Envelope delay distortion  
Absolute delay  
Phase jitter  
Transients:  
    amplitude hits  
    phase hits  
    interruptions  
    impulse noise (3-level)

**3776B**

Envelope delay distortion  
Remodulation  
Absolute delay  
Phase jitter  
Transients:  
    gain hits  
    phase hits  
    dropouts  
    impulse noise (3-level)

The following table shows the various operating modes in which the measurements are valid:

Measurements	A-A	A-D	D-A	D-D	An Tx	Dig Tx	An Rx	Dig Rx
Group delay distortion	*	*	*	*	*	*	*	*
Envelope delay distortion	*	*	*	*	-	-	-	-
Remodulation	*	*	-	-	-	-	-	-
Absolute delay	*	*	*	*	-	-	-	-
Phase jitter	*	*	*	*	*	*	*	*
Transients	*	*	*	*	*	*	*	*

An Tx - Analog Transmit only  
Dig Tx - Digital Transmit only  
An Rx - Analog Receive only  
Dig Rx - Digital Receive only

**MEASUREMENTS**

**1. GROUP DELAY - 3776A ONLY**

**Analog Transmitter**

Frequency range: 200 to 3600Hz

Error introduced by Tx: <+/-10us

Tx signal level: >-40dBm

Tx carrier level accuracy: 0.3dB

Note: 40% modulation adds approximately 0.33dB to signal level.

**Analog Receiver**

Frequency range: 200 to 3600Hz

Measurement range:

relative delay - 0 to +/-10ms

relative amplitude - 0 to +/-10dB

Signal level range (Ref and Meas): >-40dBm

**a) Relative delay measurement  
measurement error:**

Frequency range (Hz)	Rx error (us)
200 to 400	+/-35
400 to 600	+/-15
600 to 3600	+/-10

(< +/-3dB relative attenuation, REF to MEAS;  
100ppm, signal freq to Rx freq)

Typical additional error due to relative levels, REF to MEAS:

REF to MEAS (dB)	Error (us)
< +/-6	+10
< +/-10	+20
< -15	+60

Typical error due to gaussian white noise 26dB below carrier: <20us RMS  
Typical error due to single tone 150Hz from carrier, +26dB  
below carrier: <20us

(NOTE: When the received test signal has passed through a PCM system,  
the sampling and quantising process of the system under test will  
cause spreading of results, with deviation of approximately 50 to 60us).

**b) Relative amplitude measurement  
Rx accuracy: +/-0.2dB nominal**

**c) Frequency measurement  
Accuracy: +/-10Hz nominal**

**Digital Transmitter**

Frequency range: 200 to 3600Hz  
 Delay error introduced by Tx: nil  
 Tx signal level: > -20dBm0  
 Tx carrier level accuracy: 0.3dB  
 Note: 40% modulation adds approximately 0.33dB to signal level

**Digital Receiver**

Frequency range: 200 to 3600Hz  
 Measurement range:  
     relative delay - 0 to +/-10ms  
     relative amplitude - 0 to +/-10dB  
 Signal level range (Ref and Meas): > -30dBm0

**a) Relative delay measurement**

Rx error: +/-10us  
 (< +/-3dB relative attenuation, REF to MEAS;  
 < 100ppm, signal freq to Rx freq)

Typical additional error due to relative levels:

REF to MEAS (dB)	Error (us)
< +/-6	+/-10
< +/-10	+/-20
< -15	+/-60

Typical additional error for 1% f, signal freq to Rx freq: +/-15us  
 Typical error due to gaussian white noise 26dB below carrier: < 20us RMS  
 Typical error due to single tone, 150Hz from carrier, +26dB below carrier: < 20us

(NOTE: When the received test signal has passed through a PCM system, the sampling and quantising process of the system under test will cause spreading of results, with deviation of approximately 50 to 60us).

**b) Relative amplitude measurement**

Accuracy: +/-0.2dB nominal

**c) Frequency measurement**

Accuracy: +/-10Hz nominal

**2. ABSOLUTE DELAY**

**Analog Transmitter**

Signal: modulated fixed frequency carrier  
 Carrier frequency range: 300 to 3500Hz

**Modulation index:**

3776A - 0.4 +/-0.05

3776B - 0.5 +/-0.05

**Modulation frequency:**

3776A - 41 2/3 +/-0.1%

3776B - 83 1/3 +/-0.1%

**Analog Receiver****Signal range:** >-40dBm**Measurement error:** <20us**Measurement range:**

3776A - 0 to 24ms

3776B - 0 to 12ms

**Digital Transmitter****Signal:** modulated, fixed frequency carrier**Carrier frequency range:** 300 to 3500Hz**Modulation index:**

3776A - 0.4 +/-0.05

3776B - 0.5 +/-0.05

**Modulation frequency:**

3776A - 41 2/3 +/-0.1%

3776B - 83 1/3 +/-0.1%

**Digital Receiver****Signal level:** >-20dBm0**Measurement error:** <20us**Measurement range:**

3776A - 0 to 24ms

3776B - 0 to 12ms

(NOTE: When the received test signal has passed through a PCM system, the sampling & quantising process of the system under test will cause spreading of the results, deviating by a few micro-seconds.)

**3. ENVELOPE DELAY****Analog Transmitter****Frequency range:** 300 to 3500Hz**Error introduced by Tx:** <+/-10us**Tx Signal level:** >-40dBm**Tx flatness:** <+/-0.2dB

**Analog Receiver**

Frequency range: 300 to 3500Hz

Measurement range:

relative delay 3776A - +/-12ms  
3776B - -3 to +9ms

Signal level range: >-40dBm

**a) Relative delay measurement**

Measurement error:

Frequency (Hz)	Error (us)
> 300	< +/-20
> 500	< +/-15

(S/N Ratio > 35dB)

Typical additional error (S/N Ratio of 24dB): < +/-10us

(NOTE: When the received test signal has passed through a PCM system, the sampling & quantising process of the system under test will cause spreading of the results, deviating by a few micro-seconds.)

**b) Relative amplitude measurement**

Rx accuracy: +/-0.2dB nominal

**c) Frequency measurement**

Accuracy: +/-10Hz nominal

**Digital Transmitter**

Frequency range: 300 to 3500Hz

Delay error introduced by Tx: nil

Tx signal level: > -20dBm0

Tx flatness: ideal

**Digital Receiver**

Frequency range: 300 to 3500Hz

Measurement range:

relative delay 3776A - +/-12ms  
3776B - -3 +9ms

Signal level range: >-20dBm0

**a) Relative delay measurement**

Measurement error (S/N ratio > 35dB): +/-5us

Typical additional error (S/N ratio of 24dB): +/-10us

(NOTE: When the received test signal has passed through a PCM system, the sampling & quantising process of the system under test will cause



spreading of the results, deviating by a few micro-seconds.)

b) Relative amplitude measurement

Rx accuracy: +/-20dB nominal

c) Frequency measurement

Accuracy: +/-10Hz nominal

4. RE-MODULATION - 3776B ONLY

Analog Transmitter

Frequency range: 300 to 3500Hz

Error introduced by Tx: <+/-10us

Tx signal level: >-40dBm

Tx flatness: <+/-0.2dB

Analog Receiver

Received frequency measurement accuracy: +/-10Hz

Rx Signal level: >-40dBm

Envelope delay introduced by receiver:

300 to 500Hz - <+/-50us

500 to 3500Hz - <+/-15us

Digital Receiver

Received frequency measurement accuracy: +/-10Hz

Rx signal level: >-40dBm

Envelope delay introduced by receiver: nil

5. PHASE JITTER

Analog Transmitter

Frequency range: 1010 to 1020Hz

Level accuracy: +/-0.10dB

(for levels >-30dBm)

Analog Receiver

Frequency range: 990 to 1030Hz

Carrier level: >-40dBm

Measurement range: 30 degrees p-p

Measurement accuracy: +/-5% +/-0.2 degrees

Spread of readings: <0.7 degrees

Selectable filters

Filter A - 20 to 300Hz

Filter B - 4 to 300Hz

Detection: true peak-to-peak

Settling time: (within 0.7° of final reading)

Filter A - <4 seconds

Filter B - <25 seconds

Typical white noise rejection at S/N ratio 30dB: <4 degrees p-p jitter

Modulation measurement weighting characteristics  
(two tone method):

f using filter A (Hz)	2	5	10	-	-	12	20-240	300	500	700
f using filter B (Hz)	0.4	1	2	4	6	-	8-240	300	500	700
Reading (degree p-p)	<1	<3	<8	9.2 to 12.2	10.2 to 12.2	<10	10.8 to 12.2	10 to 12.2	<3	<1

Amplitude modulation to phase modulation conversion:

3776A - < 0.2 degrees over 20 to 300Hz

3776B - < 1 degree p-p over 2 to 900Hz

Averaging time:

Gate frequency	5Hz	1Hz
Display variation	<10%	>40%

**Digital Transmitter**

Frequency range: 1010 to 1020Hz

Level accuracy: +/-0.01dB

(for levels >-30dBm0)

**Digital Receiver**

Frequency range: 900 to 1030Hz

Carrier level: >-40dBm0

Measurement range: 30 degrees p-p

Measurement accuracy: +/-5% +/-0.02 degrees

Spread of readings: <0.7 degrees

Selectable filters:

Filter A - 20 to 300Hz

Filter B - 4 to 300Hz

Detection: true peak-to-peak

Settling time:

Filter A - < 4 seconds

Filter B - < 25 seconds

Typical white noise rejection at S/N ratio 30dB: <4 degrees p-p jitter

**Modulation measurement weighting characteristics  
(two tone method):**

f using filter A (Hz)	2	5	10	-	-	12	20-240	300	500	700
f using filter B (Hz)	0.4	1	2	4	6	-	8-240	300	500	700
Reading (degree p-p)	<1	<3	<8	9.2 to 12.2	10.2 to 12.2	<10	10.8 to 12.2	10 to 12.2	<3	<1

**Amplitude modulation to phase modulation conversion:**

3776A - < 0.2 degrees over 20 to 300Hz

3776B - < 1 degree p-p over 2 to 900Hz

**Averaging time:**

Gate frequency (Hz)	5	1
Display variation (%)	<10	>40

**6. TRANSIENTS**

**Analog Transmitter**

Frequency range: 1010 to 1020Hz

Level accuracy: +/-0.10dB

(for levels >-30dBm)

**Analog Receiver**

**Simultaneous measurements of:**

- gain hits
- phase hits
- interruptions (3776A)
- dropouts (3776B)
- impulse noise (3-levels)

**GENERAL**

Measurement time: programmable between 1min and 9hr 59min in 1min steps; or continuous

Count capacity: up to 9998 counts for each measurement; 9999 indicates overflow

Carrier Rx frequency range: 995 to 1025Hz

**a) GAIN HITS**

Carrier level: >-40dBm

Thresholds: selectable 2, 3, 4 or 6dB

Accuracy: +/-0.5dB

Qualification period: 3.5 to 4.5ms

Loop recovery: with a 4dB change in carrier level in time T  
 - to register 2dB hit: T <200ms  
 - not to register 2dB hit: T >600ms

**Count rate:**

slow count - nominal 8 counts/s  
 fast count (3776B only) - nominal 100 counts/s

Phase to amplitude conversion: nominal 180 degrees phase change in  
 <0.2ms does not count on 2dB threshold

**Dead time:**

slow - 125ms +/-10% nominal  
 fast (3776B) - 10ms +/-20% nominal

**b) PHASE HITS**

Carrier level: >-40dBm

Threshold accuracy on slow count: +/-10% of threshold +/-0.5 degrees

Range: 5 degrees to 40 degrees in 5 degrees steps

Qualification period: 3.5 to 4.5ms

Loop recovery: with a linear phase variation of carrier over  
 100° in either direction in time T

- for 20° hit to be registered: T <20ms  
 - for 20° hit not to register: T >50ms

**Count rate:**

slow - nominal 8 counts/s  
 fast (3776B) - nominal 100 counts/s

Amplitude to phase modulation conversion: 10dB gain hit in < 0.2ms  
 does not record 10 degrees phase hit.

**Dead time:**

slow - 125ms +/-10% nominal  
 fast (3776B) - 10ms +/-20% nominal

**c) INTERRUPTIONS (3776A)**

Carrier level: >-30dBm at start of measurement

Threshold/ref carrier level at start: -10dB +/-1dB

Qualification period: 2.5 to 4.0ms

**Dead time:**

slow - 125ms +/-25ms nominal  
 fast - 3ms +/- 1ms nominal

Lockout: an interruption blocks counting of other transients for  
 duration of interruptions plus 1s +/-10% nominal.

**d) DROPOUTS (3776B)**

Carrier level: >-28dBm at start of measurement

Threshold/ref carrier level at

start of measurement: -12dB +/-1dB

Qualification period: 3.5 to 4.5ms

**Count rate:**

slow - nominal 1 counts/s  
 fast - nominal 100 counts/s

Interlock: (a dropout blocks counting of other transients)

slow - duration of dropout plus 1s +/-10%  
 fast - duration of dropout plus 6ms nominal

**e) IMPULSE NOISE**

Thresholds: three thresholds; programmable in 1dB steps

Threshold spacing:

3776A - +3dB

3776B - +4dB

Threshold range: (lowest threshold)

3776A - -6 to -40dBm

3776B - -8 to -40dBm

Threshold accuracy (for thresholds  $> -25\text{dBm}$ ):  $\pm 1\text{dB}$

Carrier rejection:  $> 55\text{dB}$

Filters:

3776A - Selectable as

Filter A: 200Hz high pass, with 1kHz notch

Filter B: 600 to 3000Hz, with 1kHz notch

Filter C: 300 to 500Hz, with 1kHz notch

3776B - notched C-message

Count rate:

slow - nominal 8 counts/s

fast - nominal 100 counts/s

Dead time:

slow - 125ms  $\pm 10\%$  nominal

fast - 10ms  $\pm 10\%$  nominal

**Digital Transmitter**

Frequency range: 1010 to 1020Hz

Level accuracy:  $\pm 0.01\text{dB}$

(for levels  $> -30\text{dBm0}$ )

**Digital Receiver**

Simultaneous measurements of:

gain hits

phase hits

interruptions (3776A)

dropouts (3776B)

impulse noise (3-levels)

Measurement time: programmable between 1 min and 9hr 59min in 1min

steps; or continuous

Count capacity: up to 9998 counts for each measurement; 9999

indicates over flow

Carrier Rx frequency range: 995 to 1025Hz

**a) GAIN HITS**

Carrier level:  $> -30\text{dBm0}$

Thresholds: selectable 2, 3, 4 or 6dB

Accuracy:  $\pm 0.5\text{dB}$

Qualification period: 3.5 to 4.5ms

Loop recovery: with a 4dB change in carrier level in time T

- to register 2dB hit:  $T < 200\text{ms}$

- not to register 2dB hit:  $T > 600\text{ms}$

**Count rate:**

slow - nominal 8 counts/s  
 fast (3776B) - nominal 100 counts/s

**Phase to amplitude conversion:** nominal 180 degrees phase change in  
 <0.2ms does no count on 2dB threshold

**Dead time:**

slow - 125ms +/-10% nominal  
 fast (3776B) - 10ms +/-20% nominal

**b) PHASE HITS**

**Carrier level:** >-30dBm0

**Threshold accuracy on slow count:** +/-10% of threshold +/-0.5 degrees  
**Range:** 5 degrees to 40 degrees in 5 degrees steps

**Qualification period:** 3.5 to 4.5ms

**Loop recovery:** with a linear phase variation of carrier level over  
 100° in either direction in time T

- for 20° hit to be registered: T <20ms
- for 20° hit not to register: T >50ms

**Count rate:**

slow - nominal 8 counts/s  
 fast (3776B) - nominal 100 counts/s

**Amplitude to phase modulation conversion:**

10dB gain hit in < 0.2ms does not record 10 degrees phase hit

**Dead time:**

slow - 125ms +/-10% nominal  
 fast (3776B) - 10ms +/-20% nominal

**c) INTERRUPTIONS (3776A)**

**Carrier level:** >-30dBm0

**Threshold/ref carrier level at start of measurement:** -10dB +/-1dB

**Qualification period:** 2.5 to 3.5ms

**Dead time:**

slow - 125ms +/-25ms nominal  
 fast - 3ms +/- 1ms nominal

**Lockout:** an interruption blocks counting of other transients for  
 duration of interruption plus 1s +/-10% nominally

**d) DROPOUTS (3776B)**

**Carrier level:** >-18dBm0 at start of measurement

**Threshold/ref carrier level at start of measurement:** -12dB +/-1dB

**Qualification period:** 3.5 to 4.5ms

**Count rate:**

slow - nominal 1 counts/s  
 fast - nominal 100 counts/s

**Interlock:** (a dropout blocks counting of other transients)

slow - duration of dropout plus 1s +/-10% nominal  
 fast - duration of dropout plus 6ms nominal

**e) IMPULSE NOISE**

**Thresholds:** three thresholds; programmable in 1dB steps

**Threshold spacing:**

3776A - +3dB

3776B - +4dB

**Threshold range:** (lowest threshold)

3776A - -9 to -40dBm0

3776B - -11 to -40dBm0

**Threshold accuracy (for thresholds >-25dBm):** +/-1dB

**Carrier rejection:** >55dB

**Filters:**

3776A - selectable as

Filter A: 200Hz high pass, with 1kHz notch

Filter B: 600 to 3000Hz, with 1kHz notch

Filter C: 300 to 500Hz, with 1kHz notch

3776B - notched C-message

**Count rate:**

slow - nominal 8 counts/s

fast - nominal 100 counts/s

**Dead time:**

slow - 125ms +/-10% nominal

fast - 10ms +/-10% nominal









## SECTION II INSTALLATION

### 2-1 INTRODUCTION

2-2 This section provides installation instructions for the Hewlett-Packard Models 3776A and 3776B PCM Terminal Test Sets and their accessories. This section also includes information about initial inspection and damage claims, preparation for use, packaging, storage and shipment.

### 2-3 INITIAL INSPECTION

#### WARNING

**TO AVOID HAZARDOUS ELECTRICAL SHOCK, DO NOT PERFORM ELECTRICAL TESTS WHEN THERE ARE SIGNS OF SHIPPING DAMAGE TO ANY PORTION OF THE OUTER ENCLOSURE (COVERS, PANELS, METERS).**

2-4 Inspect the shipping container for damage. If the shipping container or cushioning material is damaged, it should be kept until the contents of the shipment have been checked for completeness and the instrument has been checked mechanically and electrically. The contents of the shipment should be as shown in Figure 1-1; procedures for checking electrical performance are given in Section IV. If the contents are incomplete, if there is mechanical damage or defect or if the instrument does not pass the Performance Tests, notify the nearest Hewlett-Packard office. If the shipping container is damaged or the cushioning material shows signs of stress, notify the carrier as well as the Hewlett-Packard office. Keep the shipping materials for the carriers inspection. The HP office will arrange for repair or replacement at HP option without waiting for claim settlement.

### 2-5 PREPARATION FOR USE

#### WARNING

**TO AVOID THE POSSIBILITY OF INJURY OR DEATH, THE FOLLOWING PRECAUTIONS MUST BE FOLLOWED BEFORE THE INSTRUMENT IS SWITCHED ON.**

(A) NOTE THAT THE PROTECTION PROVIDED BY GROUNDING THE INSTRUMENT CABINET MAY BE LOST IF ANY POWER CABLE OTHER THAN THE THREE-PRONGED TYPE SUPPLIED IS USED TO COUPLE THE AC LINE VOLTAGE TO THE INSTRUMENT.

(B) IF THIS INSTRUMENT IS TO BE ENERGIZED VIA AN AUTO-TRANSFORMER TO REDUCE OR INCREASE THE LINE VOLTAGE, MAKE SURE THAT THE COMMON TERMINAL IS CONNECTED TO THE NEUTRAL POLE OF THE POWER SOURCE.

(C) THE POWER CABLE PLUG SHALL ONLY BE INSERTED INTO A SOCKET OUTLET PROVIDED WITH A PROTECTIVE EARTH CONTACT. THE PROTECTIVE ACTION MUST NOT BE NEGATED BY THE USE OF AN EXTENSION CORD WITHOUT A PROTECTIVE CONDUCTOR (GROUNDING).

**2-6 Power Requirements**

2-7 The instrument requires a power source of 115V or 240V ac, +10% -22%, 48 to 66Hz single phase. The maximum power consumption is 100VA. Refer to Para 2-49 for details of the internal battery associated with Assembly A14 (Memory).

**2-8 Line Voltage Selection and Fuse**

2-9 The line voltage is selected by the rear panel switch labelled 115V and 230V.

**CAUTION**

Before connecting the instrument to a power outlet ensure that the line voltage selector is correctly set, and that a fuse of the correct rating is fitted.

2-10 Fuse ratings are given in Table 2-1.

**Table 2-1 Fuses**

Nominal Line	Fuse Rating	HP Part Number
115V	3AT	2110-0381
230V	2AT	2110-0303

**2-11 Power Cable**

2-12 This instrument is equipped with a three-wire power cable. When connected to a power outlet, this cable grounds the instrument case. The type of power cable shipped with each instrument depends on the country of destination. Refer to Figure 2-1 for part numbers of the power cable and plug configurations available. The number shown below each plug is the Hewlett-Packard part number of a power cord equipped with that plug. If the appropriate power cord is not included with the instrument, notify the nearest Hewlett-Packard Sales and Service Office and a replacement will be provided.

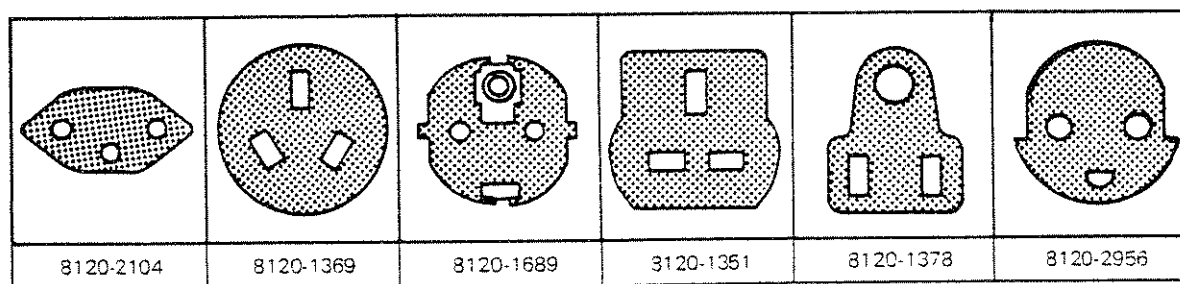

**Figure 2-1 Power Receptacles**

2-13 The colour code used in each power cable is given below:

Line: Brown  
Neutral: Blue

Ground: Green/Yellow

## 2-14 Operating Environment

2-15 Temperature - The instrument may be operated in temperatures from 0 degrees centigrade to +55 degrees centigrade.

2-16 Humidity - The instrument may be operated in environments with humidity up to 95%. However, the instrument should also be protected from temperature extremes which may cause condensation within the instrument.

2-17 Altitude - The instrument may be operated at altitudes up to 4600m (15,000ft).

2-18 Air flow - The air intake to the instrument is via a fan mounted on the rear panel. The air exhaust is via the perforated side panels. To provide adequate cooling, an air gap of approximately 3 inch should be maintained around the instrument.

## 2-19 MATING CONNECTORS

2-20 The connectors listed in Tables 2-2 and 2-3 mate with the 3776 PCM Terminal Test Set. Details of HP-IB cables are given in Table 2-4 and details of the mains power cables are given in 2-1. Figure 2-2 identifies the front panel connectors.

Table 2-2 Rear Panel Connectors

Reference	Function	HP Part Number	Mating Connector
J1 - J4	SEE NOTE BELOW		
J9	DIG Tx CLOCK	1250-1253	Standard: 50Ω BNC to suit cable diameter. e.g.: Body: 1250-0052 Contact: 1250-0298 Bush/Clamp: 1250-0050
A23J2	HP-IB Connector	1251-4040	1251-0293
A23J3	DIG Rx DATA OUTPUT	1251-5503	1251-0219

Note: J1 - J4 fitted on rear panel on 3776B Option 004 only.

For details and connector configuration refer to Table 2-3 and Figure 2-2 on following page.

Table 2-3 Front Panel Connectors

Function	Ref	3776A/B/ Option	Connector Type	HP Part Number	Mating Conn. Part No.		
DIGITAL	Rx	J1*	A	STD. 001, 002	Siemens <i>BANTAM</i>	1251-5586	5060-4444
			B	STD. 001 002 004	<del>WECO 310</del> I240 Trompeter	1251-3059 1251-8589 1250-1639	1251-3060 Ord. Banana 1250-1413
		J5	A	STD. 001 002	BNC (75Ω) Siemens	1250-0610 1250-1077	1250-1448 1250-1078
			B	STD. 001	<i>WECO 310</i> <del>Bantam</del>	1251-3677	1251-0695
	Tx	J4*	A	STD. 001, 002	Siemens	1251-5586	5060-4444
			B	STD. 001 002 004	WECO 310 I240 Trompeter	1251-3059 1251-8589 1250-1639	1251-3060 Ord. Banana 1250-1413
		J6	A	STD. 001 002	BNC (75Ω) Siemens	1250-0610 1250-1077	1250-1448 1250-1078
			B	STD. 001	Bantam	1251-3677	1251-0695
ANALOG	Rx	J2*	A	STD. 001, 002	Siemens	1251-5586	5060-4444
			B	STD. 001 002 004	WECO 310 I240 Trompeter	1251-3059 1251-8589 1250-1639	1251-3060 Ord. Banana 1250-1413
		J8	B	STD. 001	Bantam	1251-3677	1251-0695
	Tx	J3*	A	STD. 001, 002	Siemens	1251-5586	5060-4444
			B	STD. 001 002 004	WECO 310 I240 Trompeter	1251-3059 1251-8589 1250-1639	1251-3060 Ord. Banana 1250-1413
		J7	B	STD. 001	Bantam	1251-3677	1251-0695

\* Located on rear panel on 3776B Option 004. Two sets of cables are available (see para 1-26 on Page 1-4).

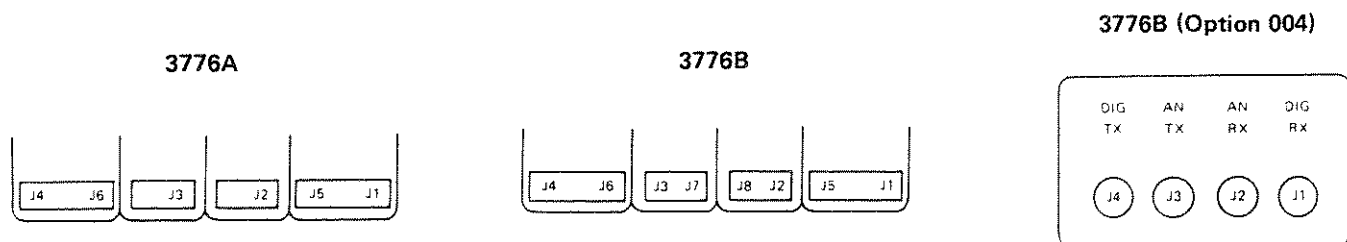
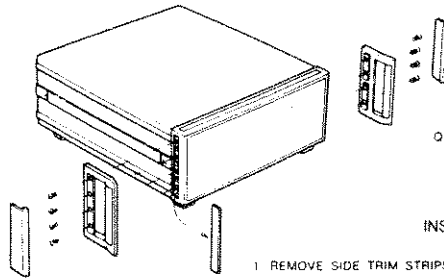

Figure 2-2 Connector Configuration

**2-21 RACK MOUNTING**

2-22 Illustrated in Figure 2-3 are the three Rack Mount Kits available with the 3776. See Paragraph 2-18 regarding the cooling of rack mounted instruments.

**7H FRONT HANDLE KIT**  
 [PRODUCT HT 1770mm 6 969 in]  
 HP PART NUMBER 5061-0090 (OPTION 907)



QTY	CONTENTS	PART NO
2	FRONT HANDLE ASSY	5060-9900
2	FRONT HANDLE TRIM	5020-8897
8	#8-32 x 3/8 SCREW	2510-0195

**INSTRUCTIONS**

- 1 REMOVE SIDE TRIM STRIPS.
- 2 ATTACH FRONT HANDLE ASSY WITH 4 SCREWS PER SIDE
- 3 PRESS FRONT HANDLE TRIM IN PLACE

**7H RACK MOUNT KIT WITH FRONT HANDLES**  
 [PRODUCT HT 1770mm 6 969 in]  
 HP PART NUMBER 5061-0084 (OPTION 908)

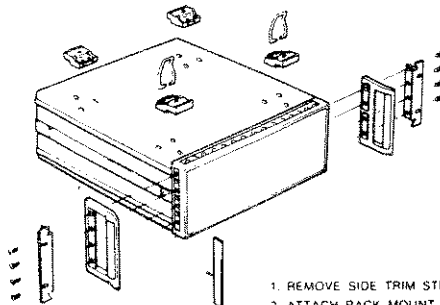

QTY	CONTENTS	PART NO
2	RACK MOUNT FLANGE	5020-8875
2	FRONT HANDLE ASSY	5060-9900
8	#8-32 x 5/8 SCREW	2510-0194

**INSTRUCTIONS**

1. REMOVE SIDE TRIM STRIPS.
- 2 ATTACH RACK MOUNT FLANGE AND FRONT HANDLE ASSY WITH 4 SCREWS PER SIDE.
- 3 REMOVE FEET AND TILT STANDS BEFORE RACK MOUNTING

**7H RACK MOUNT KIT WITHOUT FRONT HANDLES**  
 [PRODUCT HT 1770mm 6 969 in]  
 HP PART NUMBER 5061-0078 (OPTION 908)

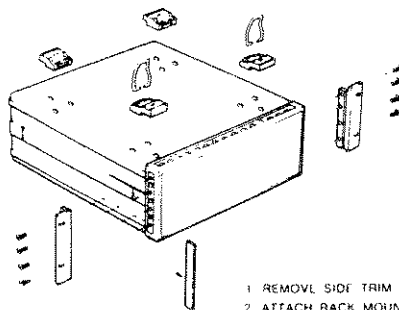

QTY	CONTENTS	PART NO
2	RACK MOUNT FLANGE	5020-8863
8	8-32 x 3 8 SCREW	2510-0193

**INSTRUCTIONS**

- 1 REMOVE SIDE TRIM STRIPS
- 2 ATTACH RACK MOUNT FLANGE WITH 4 SCREWS PER SIDE.
- 3 REMOVE FEET AND TILT STANDS BEFORE RACK MOUNTING

Figure 2-3 Rack Mount Kits

**2-23 HEWLETT-PACKARD INTERFACE (HP-IB) BUS INSTALLATION**

2-24 This section contains information and instructions on the installation of the 3776A and 3776B PCM Terminal Test Set into a Hewlett-Packard Interface Bus (HP-IB) system.

2-25 The HP-IB is Hewlett-Packard's implementation of the IEEE Standard 488-1978 (Digital Interface for Programmable Instrumentation). This standard defines a physical interface and protocol which enables the remote control of instrumentation systems.

**2-26 Connection to the HP-IB**

**Logic Levels**

The HP-IB logic levels are TTL compatible ie the true (1) state is 0V dc to 0.5V dc and the false (0) state is +2.5V to 5V dc.

**Mating Connector**

HP 1251-0293;  
Amphenol 57-302040

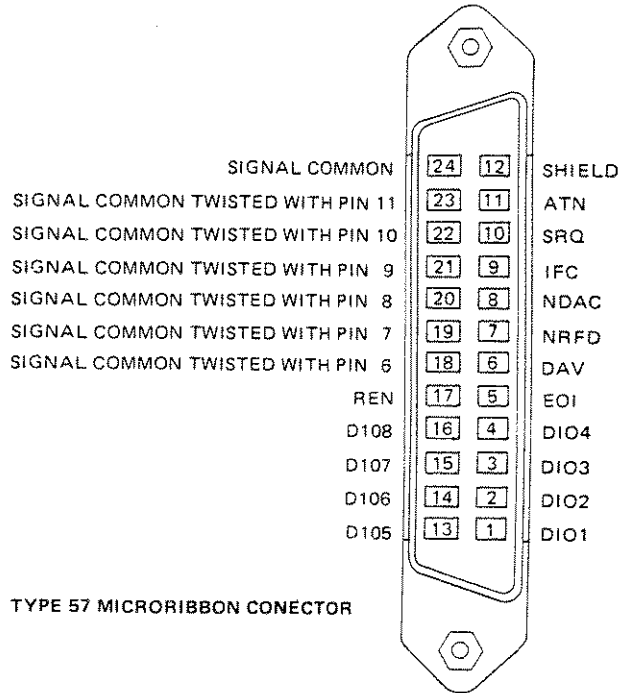

**Figure 2-4 HP-IB (rear panel) Connector**

2-27 The HP-IB connector on the rear panel of the 3776 provides the physical interface to connect the 3776 into an HP-IB system. Figure 2-4 illustrates the connector pin configuration. Devices in the HP-IB system may be interconnected in any suitable arrangement (star, delta, etc) using the HP-IB cables listed in Table 2-4 provided the restrictions given in Paragraph 2-28 are obeyed.

**Table 2-4 HP-IB Interface Cables**

HP-IB Part Numbers	Cable Lengths
HP10833A	1m (3.3ft)
HP10833B	2m (6.6ft)
HP10833C	4m (13.2ft)
HP10833D	0.5m (1.6ft)



2-28 To achieve design performance, restrictions are placed on the length of HP-IB system cable as follows:

- 1 The total length of HP-IB cable used to interconnect devices on the HP-IB must not exceed 2 metres (6 feet) times the number of devices in the system.
- 2 The total length of HP-IB cable used to interconnect all devices must not exceed 20 metres (65 feet).

**2-29 3776 CONFIGURATION**

2-30 The 3776 may be configured either in the TALK only mode in an HP-IB system containing a printer/plotter or as a device (addressable) under the remote control of a separate system controller (normally a computer or computing controller).

**2-31 3776 in TALK ONLY Mode**

2-32 In the talk only mode, an output suitable for a printer or plotter is provided at the rear panel HP-IB connector.

2-33 When the rear panel HP-IB ADDRESSABLE/TALK ONLY switch is set to TALK ONLY, the required output format is selected with the HP-IB ADDRESS/PRINT FORMAT switches (A23S1).

2-34 The output formats available are illustrated in Table 2-5.

2-35 Suitable 80 column printers are: Hewlett Packard HP 2631B, HP 2671A/G and HP 2673A.

2-36 Suitable HP GL plotters are the Hewlett Packard HP 7470A or for programmable paper advance, HP 9872C/D.

**2-37 3776 Configured as an Addressable Device**

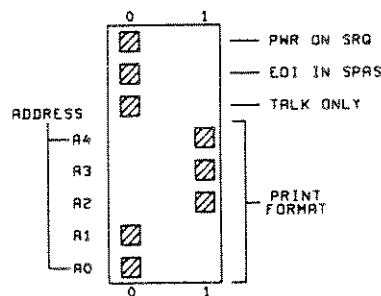

**Figure 2-5 HB-IB Switches - 3776 as an Addressable Device**

2-38 The setting of the TALK ONLY switch (see Figure 2-5) on the 3776 rear panel to the OFF (0) position configures the 3776 as an HP-IB addressable device under the remote control of a separate HP-IB controller. Each device in the HP-IB system requires a unique address to enable the system controller to differentiate between the devices. The address switches A0 to A4 shown in Figure A2-5 define the 3776 address (addresses range from 0 to 31).

Table 2-5 HP-IB Output Format

Binary value of PRINT FORMAT switches (A0 to A4)	Output format	Typical HP-IB ADDRESS/PRINT FORMAT Switch Setting
0 1	ASCII BINARY	
2	The 80 column printer output format comprises a header which includes the measurement code, operating mode and measurement parameters; and the measurement results output.	<p>Setting for 80 column printer output.</p>
8 to 31	Plotter outputs HP-GL* A3 or A4 must = 1 A3 and A4=1 not title axes A4=1 no CCITT mask A2=1 auto paper advance A1=1 Y axis scaled A0=1 X axis scaled	<p>Setting for HP-GL* plotter output. with title and axes with CCIT mask without programmable paper advance with fixed X and Y axes</p>

\*HP-GL Hewlett-Packard Graphics Language

**2-39 DIG Rx DATA OUTPUT (rear panel) Connector**

2-40 PCM bit patterns applied to the 3776 front panel DIG Rx input may be applied to other measuring equipment through a suitable TTL interface via the 3776 rear panel DIG Rx DATA OUTPUT. Figure 2-6 illustrates the pin connections of the DIG Rx DATA OUTPUT. N DATA is the serial TTL data and is formatted low true.

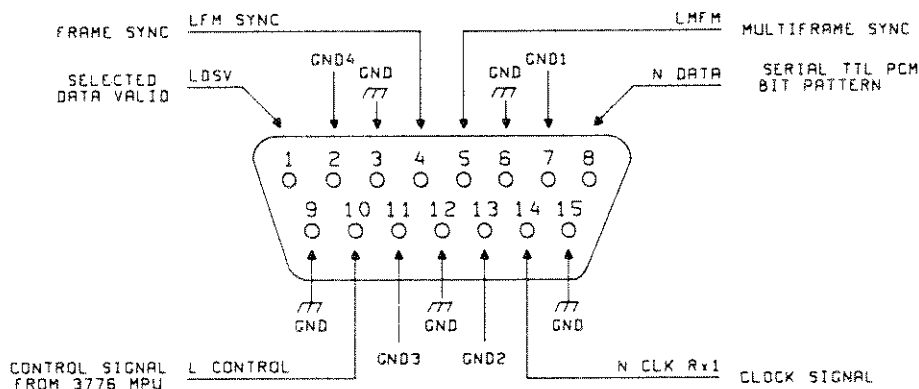

**Figure 2-6 DIG Rx DATA OUTPUT Connector**

**2-41 STORAGE AND SHIPMENT**

**2-42 Environment**

2-43 The instrument may be stored or shipped in environments within the following limits:

- Temperature.....-40 degrees centigrade to +75 degrees centigrade
- Humidity.....90%
- Altitude.....15,300m (50,000ft)

2-44 The instrument should also be protected from temperature extremes which may cause condensation within the instrument.

**2-45 Packaging**

2-46 Tagging for Service - If the instrument is being returned to Hewlett-Packard for service, please complete one of the blue repair tags located at the front of this manual and attach it to the instrument.

2-47 Original Packaging - Containers and material identical to those used in the factory packaging are available through Hewlett-Packard offices. If the instrument is being returned to Hewlett-Packard for servicing, attach a tag indicating the type of service required, return address, model number, and full serial number. Also mark the container "FRAGILE" to ensure careful handling. In any correspondence, refer to the instrument by model number and full serial number.

2-48 Other Packaging - The following general instructions should be used for re-packing with commercially available materials:

- (a) Wrap instrument in heavy paper or plastic. (If shipping to Hewlett-Packard office or service centre, attach a tag indicating type of service required, return address, model number and full serial number.)
- (b) Use strong shipping container. A double-walled carton of 350-pound test material is adequate.
- (c) Use a layer of shock absorbing material 70 to 100mm (3 to 4 inch) thick around all sides of the instrument to provide firm cushioning and prevent movement inside the container. Protect the control panel with cardboard.
- (d) Seal shipping container securely.
- (e) Mark the shipping container "FRAGILE" to ensure careful handling.
- (f) In any correspondence, refer to instrument by model number and full serial number.

#### 2-49 INTERNAL BATTERY

**WARNING**  
**DO NOT INCINERATE OR MUTILATE THE BATTERY. IT**  
**MIGHT BURST OR RELEASE TOXIC MATERIALS CAUSING**  
**PERSONAL INJURY.**

2-50 The lithium battery on A14 (used as a power supply to the non-volatile memory) should be checked annually. Life expectancy of the battery is approximately 5 years.





**SECTION III  
GETTING STARTED**

**3-1 INTRODUCTION**

3-2 This section provides a few exercises which are designed to give you a basic familiarity with the front panel controls. The main operations featured are:

- Setting transmit and receive TLPs
- Running a single point measurement
- Storing and recalling measurement parameters
- Displaying the points of a multi-point measurement
- Changing parameters in a multi-point measurement
- Inserting and deleting measurement points
- Using the CONTROL keys
- Setting up background and foreground PCM
- Setting up timeslots
- Transmitting and receiving background and foreground PCM

3-3 At the end of the section there are some notes on features not covered in these exercises but which may be usefully used as part of a familiarisation exercise.

**3-4 BEFORE GETTING STARTED**

3-5 Check that the VOLTAGE SELECTOR on the rear panel is set to the correct position for the supply being used.

Check that the DIG CLOCK INT/EXT switch is set to INT.

Check that the other rear panel switches are set as follows:

PCM FORMAT . . . . . FT  
   CCS  
   AMI(AZS)

TALK ONLY/ADDRESSABLE . . . ADDRESSABLE

Connect the DIGITAL TRANSMIT output to the DIGITAL RECEIVE input.

Connect the ANALOG TRANSMIT output to the ANALOG RECEIVE input.

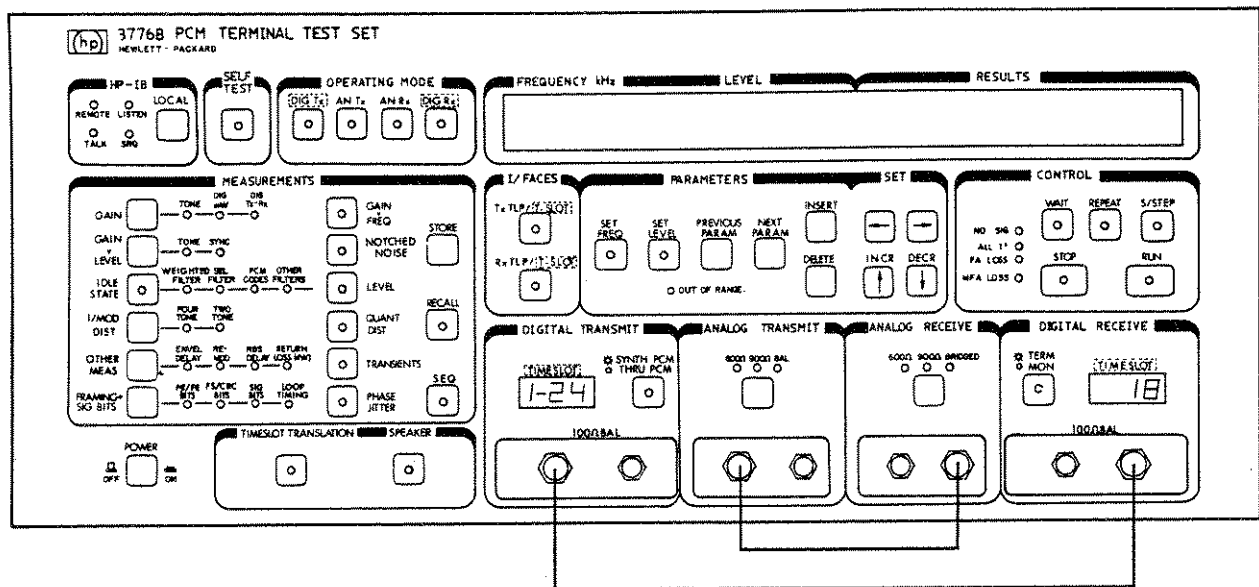

### 3-6 GETTING STARTED

3-7 A few things happen fairly quickly at switch-on and you will want to know what to expect before you push the button.

3-8 The switch-on routine performs some basic self checks. These take a few seconds and only produce a display (an error message) if one of the tests fails completely.

3-9 The last part of the switch-on routine reads the HP-IB ADDRESS switch and displays the HP-IB ADDRESS or OUTPUT FORMAT depending on the setting of the TALK ONLY/ADDRESSABLE switch. In this case, with the switch set to ADDRESSABLE, the HP-IB ADDRESS will be displayed.

### 3-10 The Default State

3-11 The instrument then defaults to:

AN Tx AN Rx OPERATING MODE, selects the GAIN TONE measurement,\* and displays the default PARAMETERS 1.01kHz, 0.0dBmO. The AN Tx and AN Rx impedances and TLPs, and DIG Tx and DIG Rx timeslots are set to their values at last switch off.

OK now you now what to expect ...SWITCH ON.

\*Except if the instrument was last switched off in transients or remod.



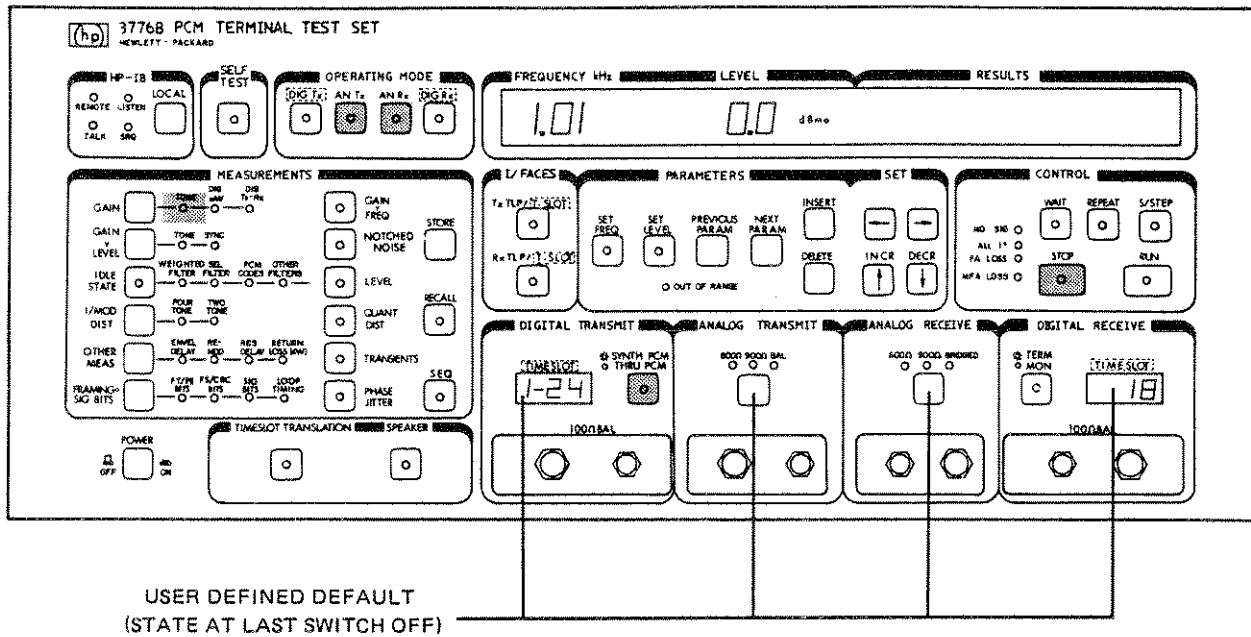

**3-12 ANALOG MEASUREMENTS**

3-13 The following exercise uses an analog to analog GAIN TONE measurement to demonstrate TLP selection and the effect of TLP on GAIN measurement results.

3-14 In this example the measurement is to be between a point at -7dB relative to the 0TLP ie -7TLP and a point at +3dB relative to the 0TLP ie 3TLP.

### 3-15 SETTING THE ANALOG Tx TLP

3-16 Press the I/FACES Tx key to display the Tx TLP, one of the level digits should start to flash (SET LEVEL is automatically enabled).

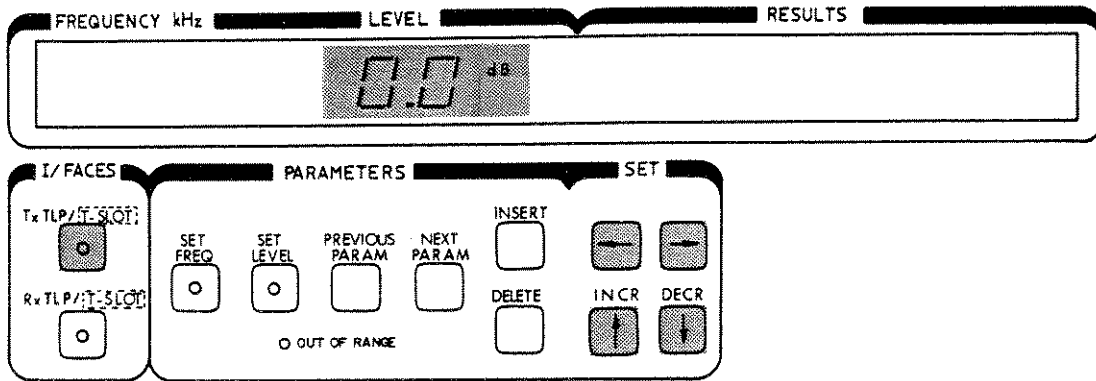

Use the ← →↑↓ keys to set the level to -7.0dB.

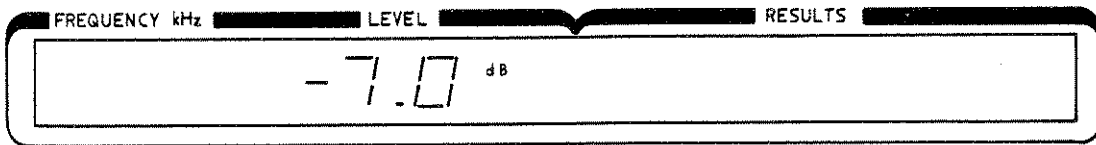

### 3-17 SETTING THE ANALOG Rx TLP

3-18 Now press the I/FACES Rx key and set the Rx TLP to 3.0dB

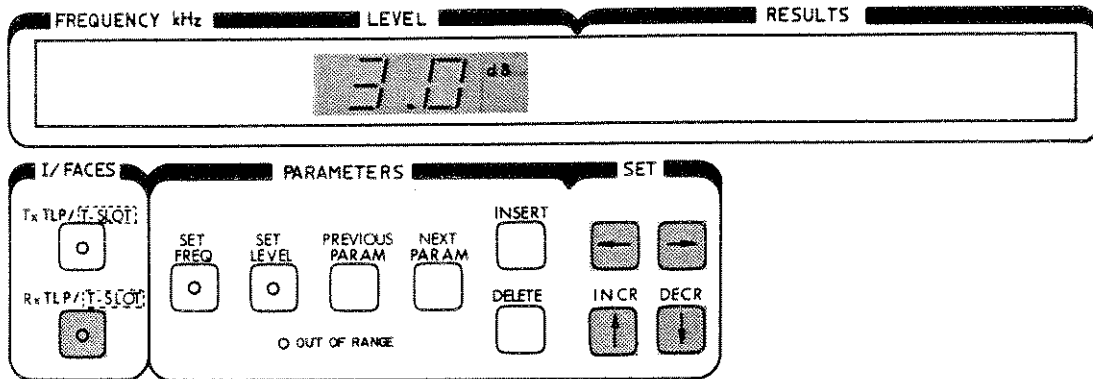

### 3-19 RUNNING A SINGLE POINT MEASUREMENT

3-20 The measurement selected before the I/FACES key was pressed remains selected. It is therefore possible to run the GAIN TONE measurement at this point by pressing the RUN key. You can check this by toggling the I/FACES key off; the GAIN TONE measurement is indicated and the measurement parameters are displayed.

You have now set up the measurement ...PRESS RUN.

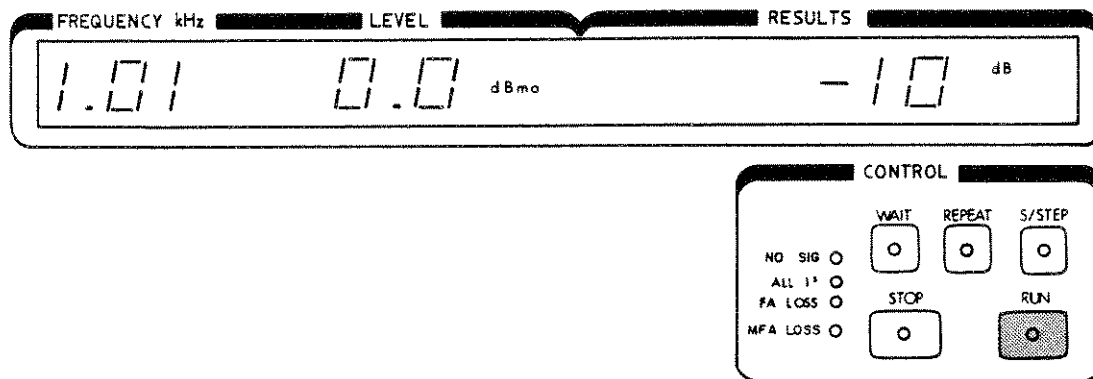

3-21 The receiver expected a signal 10dB higher than the Tx output because of the TLP settings. But you have directly connected them. The measurement result (gain, which is relative) will therefore be -10dB.

**3-22 STORE AND RECALL**

3-23 In that example the measurement level was 0.0dBm0. Suppose you chose to measure gain at a different level, say -10dBm0. Here's how you can set up the instrument for your own requirements, and store this setting for future use.

Press SET LEVEL and use the ← →↑↓ keys to set the level to -10.0dBm0.

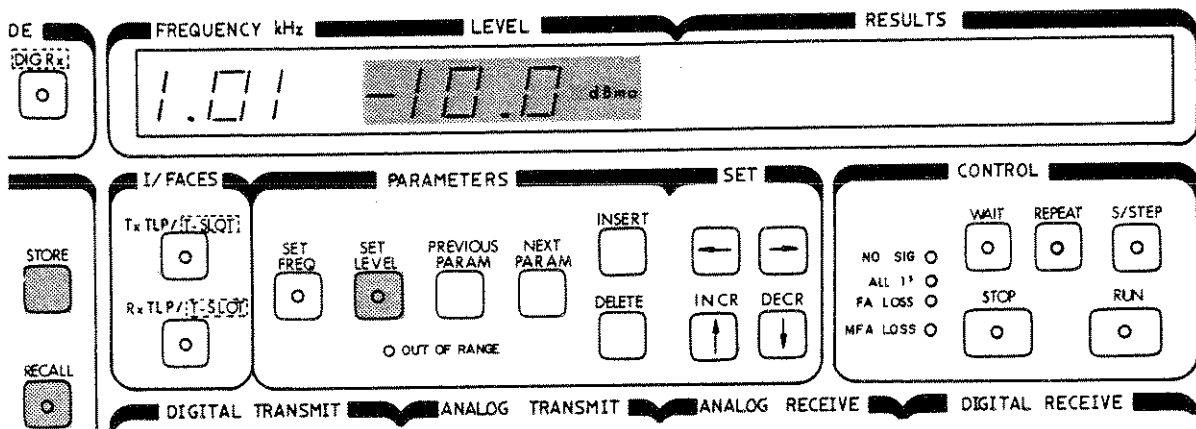

3-24 Press STORE. The indicator on the RECALL key should come on as confirmation that the storing action has taken place. The displayed parameters are now stored in non-volatile memory Toggle RECALL; the LEVEL display alternates between 0.0 and -10.0 i.e. between the ROM based default parameter settings and the RAM based user defined settings.

3-25 With the LEVEL set to -10.0dBm0, press RUN.

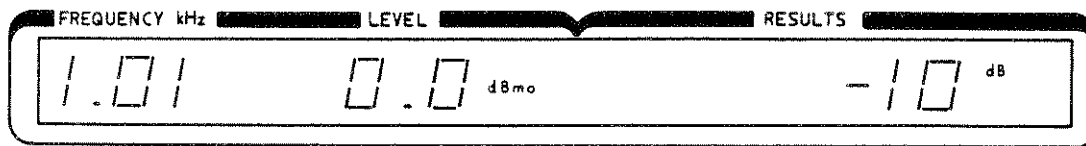

3-26 The result will still be -10dB, the gain has not changed, only the reference level. Remember for end to end measurements that this reference level must be set to the same value in both instruments.

Set the Tx and Rx TLPs to 0.0 before proceeding.

NOTE: when the TLP is set to 0.0, the values of dBm0 and dBm are the same.

NOTE: You can store a user defined version of each of the instruments measurements in NVM.

### 3-27 MULTI-POINT MEASUREMENTS

3-28 The following exercise uses a GAIN v FREQUENCY measurement to demonstrate manipulation and operation of multi-point measurements. The features demonstrated are: Changing parameters, insertion and deletion of points and running measurements.

### 3-29 Select GAIN v FREQUENCY

3-30 The first display you get shows the reference frequency and measurement level. All points in any one measurement run will be at one level.

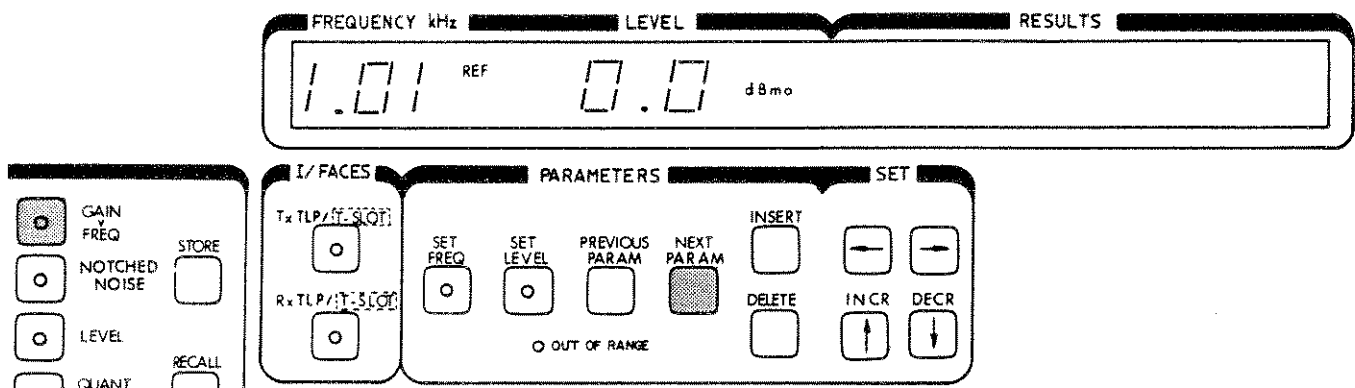

Press the NEXT PARAM key.

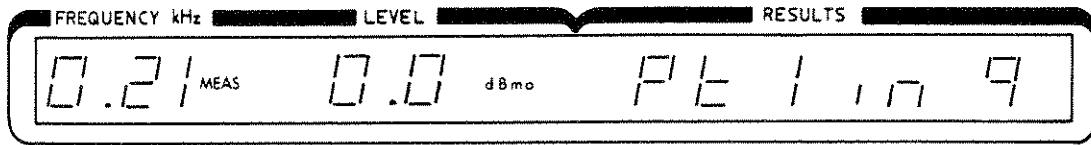

3-31 The Pt 1 in 9 display flag indicates that the point displayed is the first measurement point of a 9 point measurement.

3-32 Use the NEXT PARAM key to display each measurement point in turn. The displays obtained are:

FREQUENCY kHz	LEVEL	RESULTS
0.21 meas	0.0 dBm0	Pt 1 in 9
0.31	0.0	Pt 2 in 9
0.61	0.0	Pt 3 in 9
1.21	0.0	Pt 4 in 9
1.81	0.0	Pt 5 in 9
2.39	0.0	Pt 6 in 9
2.99	0.0	Pt 7 in 9
3.39	0.0	Pt 8 in 9
3.59	0.0	Pt 9 in 9

### 3-33 CHANGING PARAMETERS

3-34 Use the PREVIOUS PARAM key to display Pt 7 in 9

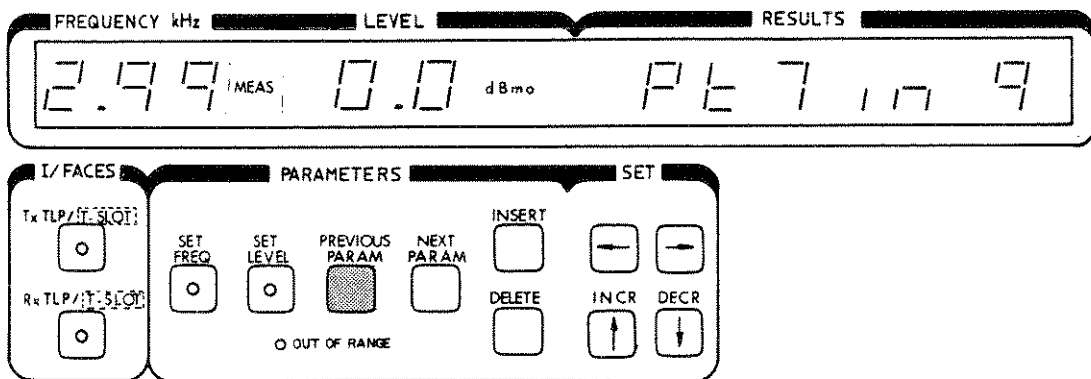

3-35 Press SET FREQ, the on key indicator should come on. Now use the ← →↑↓ keys to set the frequency to 0.99kHz. Note how you can increment/decrement the left hand digit (by positioning the flashing cursor with the ← key) so that the frequency can be quickly changed. As the frequency changes the Pt indicator flag will change from Pt 7 in 9 to Pt 4 in 9.

3-36 As a result of the frequency change, the points in the measurement are now:

FREQUENCY kHz	LEVEL	RESULTS
0.21 meas	0.0 dBm0	Pt 1 in 9
0.31	0.0	Pt 2 in 9
0.61	0.0	Pt 3 in 9
0.99	0.0	Pt 4 in 9
1.21	0.0	Pt 5 in 9
1.81	0.0	Pt 6 in 9
2.39	0.0	Pt 7 in 9
3.39	0.0	Pt 8 in 9
3.59	0.0	Pt 9 in 9

Note that the instruments software has automatically re-ordered the measurement points.

**3-37 INSERTING MEASUREMENT POINTS**

3-38 Now to insert an additional measurement point at 2.51kHz. This is done by duplicating one of the existing mask points (with the INSERT key) and changing the frequency of one of the duplicated points to the required value. You can chose any point to duplicate. Normally, for convenience you would chose a point with a value close to the value about to be inserted but in this case we are going to chose a point well away from the point to be inserted in order to demonstrate the automatic re-ordering of measurement points.

3-39 Display point 3 in 9, 0.61kHz by using the NEXT PARAM and PREVIOUS PARAM keys.

NOTE: Any point can be used for this exercise.

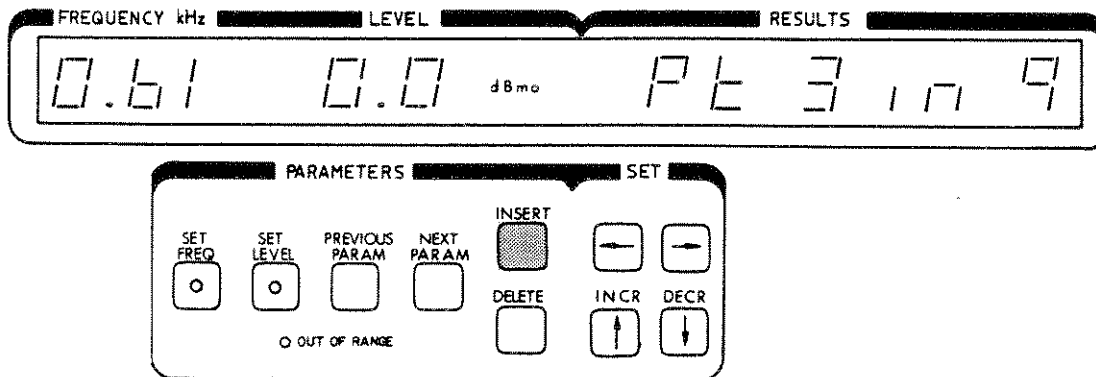

3-40 Press the INSERT key.

The measurement point has been duplicated, it is now shown as point 3 in 10

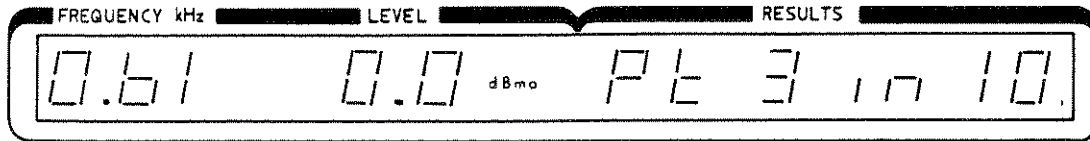

NOTE: At this stage there are two points at 0.61kHz Point 3 in 10 and Point 4 in 10

3-41 Press SET FREQ and watch the display as you set the frequency, as before, to 2.51kHz. The new point has been loaded in "ascending frequency" order. It is now point 8 in 10.

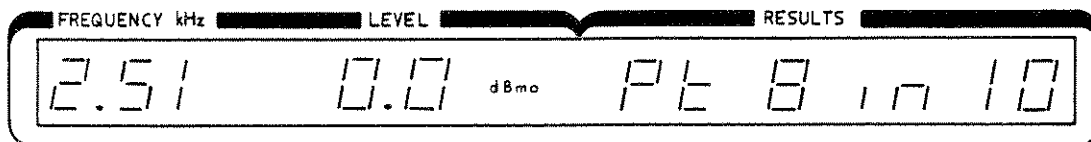

3-42 The complete list of points in the measurement is now:

FREQUENCY kHz	LEVEL	RESULTS
0.21 meas	0.0 dBm0	Pt 1 in 10
0.31	0.0	Pt 2 in 10
0.61	0.0	Pt 3 in 10
0.99	0.0	Pt 4 in 10
1.21	0.0	Pt 5 in 10
1.81	0.0	Pt 6 in 10
2.39	0.0	Pt 7 in 10
2.51	0.0	Pt 8 in 10
3.39	0.0	Pt 8 in 10
3.59	0.0	Pt 9 in 10

### 3-43 THE DELETE FUNCTION

3-44 When the instrument is in the STOP state, use the NEXT PARAM and PREVIOUS PARAM keys to display point 1 in 10 0.21kHz.



3-45 Press the DELETE key to delete that point. The next point will be displayed point 1 in 9 0.31kHz.

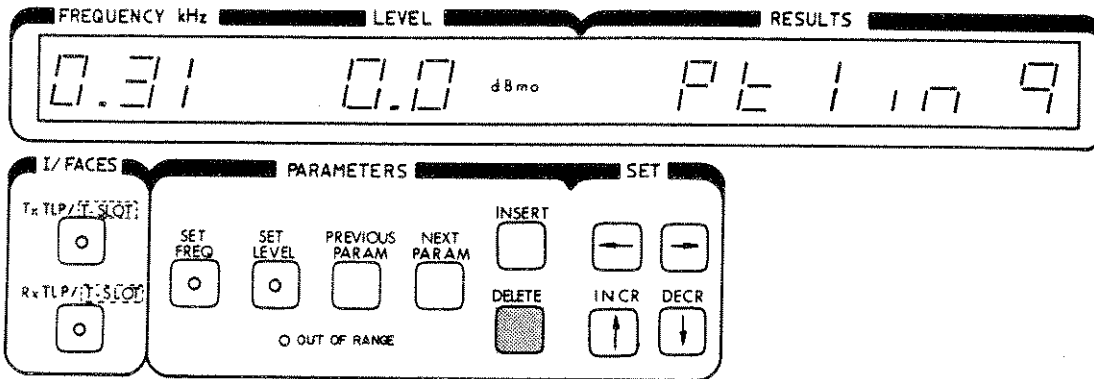

3-46 Press the delete key again. Point 1 in 8 0.61kHz will be displayed. The two lowest frequencies have been deleted from the mask leaving the eight higher frequency measurement points.

**3-47 USING THE CONTROL KEYS**

3-48 Press RUN, the measurement will run displaying results and will end in the STOP state ie with the indicator on the STOP key on.

3-49 Step through the measurement with the S/STEP key. The instrument will go to the WAIT state when each measurement point has been completed.

3-50 Press REPEAT when in the WAIT state to repeat that measurement point once.

3-51 Press RUN and then REPEAT (before the run has been completed). The current measurement point and the reference point will be continuously repeated. Toggle the speaker key for volume and off.

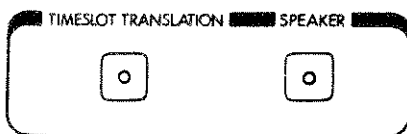
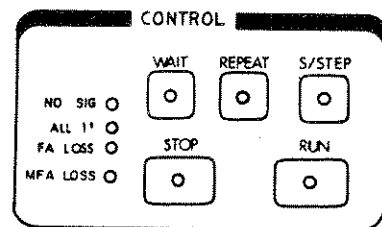

3-52 Press STOP to abort the measurement run.

3-53 Press RUN and then WAIT (before the run has been completed). The measurement will pause at the end of the current point. Now press RUN again and the measurement will continue.

**3-54 DIGITAL MEASUREMENTS**

3-55 The following exercise uses the PCM CODES LEVEL measurement to demonstrate manipulation and operation of background PCM and codes in the timeslot of interest. In this exercise we are going to have one pair of PCM codes in timeslots 2 to 24 as a background PCM and different codes in timeslot 1, the "test" timeslot, as foreground PCM.

3-56 Then we can look at the received codes in timeslots 1 and 2.

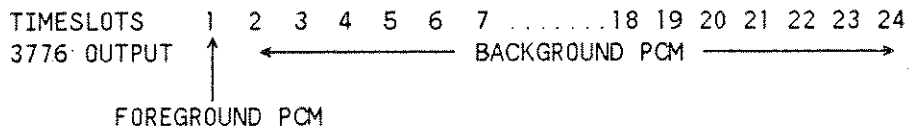

3-57 Select OPERATING MODE DIG Tx DIG Rx

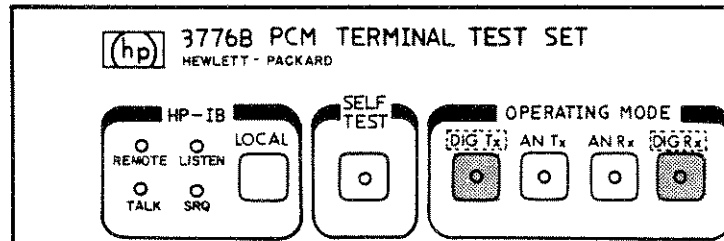

3-58 SET UP BACKGROUND PCM

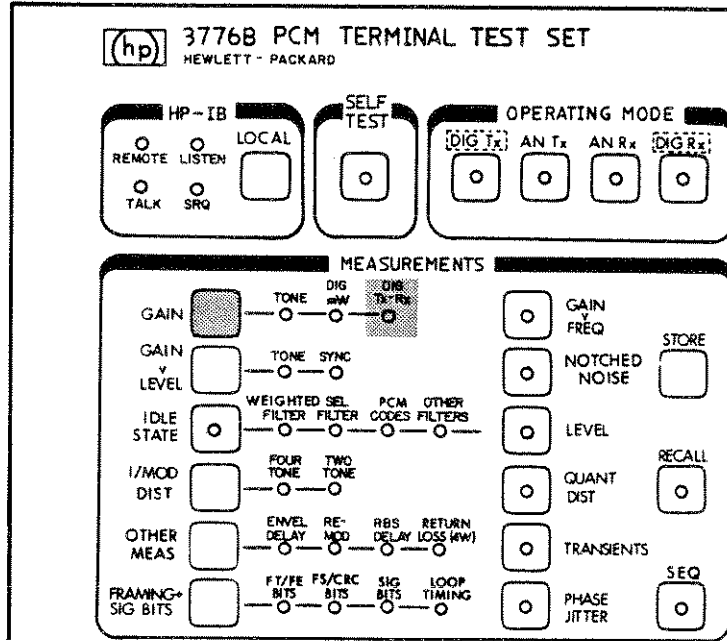

3-59 Press the MEASUREMENTS GAIN key to get the DIG Tx-Rx indicator "on".

3-60 With the DIG Tx-Rx measurement, the digital transmitter transmits a pair of codes and the digital receiver detects the received pair of codes and displays them. The pair of codes selected for this measurement are automatically selected as background idle codes, i.e. the PCM signal in the unselected timeslots, for other digital measurements.

The display shows one of the pair of Tx codes.

3-61 Use SET LEVEL AND  $\leftarrow \rightarrow \uparrow \downarrow$  to change the display to 15.

The 1 of 2 display flag is "on", so use the NEXT PARAM key to GET THE second display, Tx code.

Change this code to -15, and press STORE.

3-62 The STORE operation in this case puts the new values in non-volatile memory and these become the background idle codes. The operation can be repeated later with the original values to return the instrument to the state you found it in.

**3-63 TRANSMIT TIMESLOT SELECTION**

3-64 Press the I/FACES Tx key to enable Tx timeslot selection

Use the  $\uparrow \downarrow$  keys to set the Tx timeslot to 1

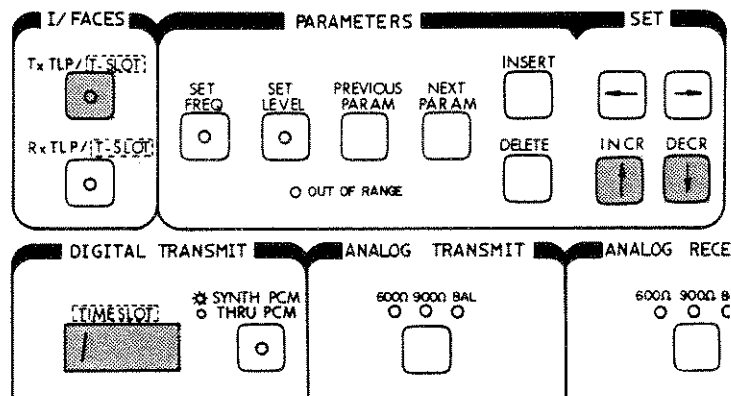

**3-65 RECEIVE TIMESLOT SELECTION**

3-66 Press the I/FACES Rx key to enable Rx timeslot selection

Use the  $\uparrow\downarrow$  keys to set the Rx timeslot to 1

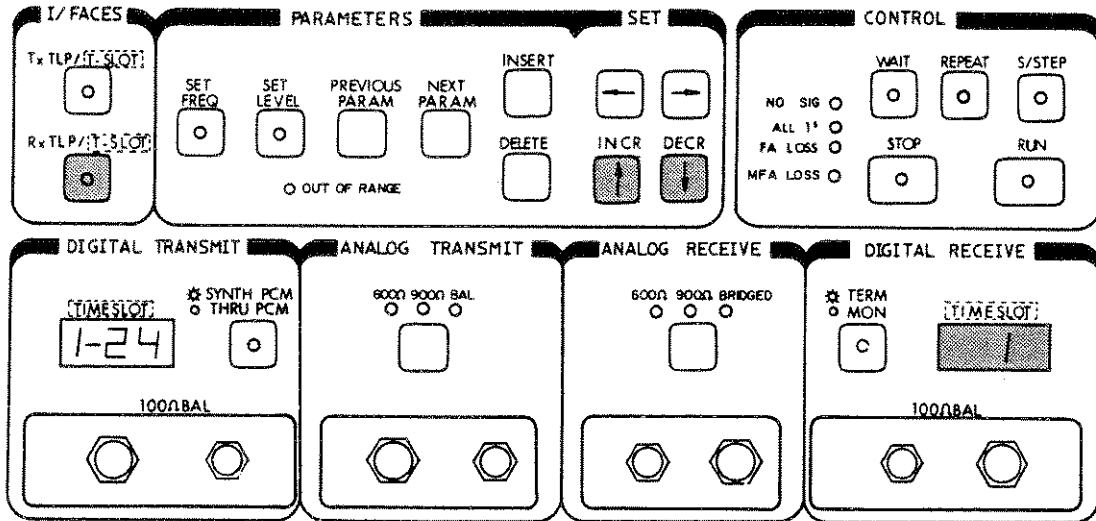

### 3-67 DIGITAL TIMESLOT MANIPULATION

3-68 Press MEASUREMENTS LEVEL to get the PCM CODES indicator on. With this measurement, a signal is coded and transmitted, and the peak positive and negative codes received are displayed. The display shows the frequency and level of the output in the Tx timeslot.

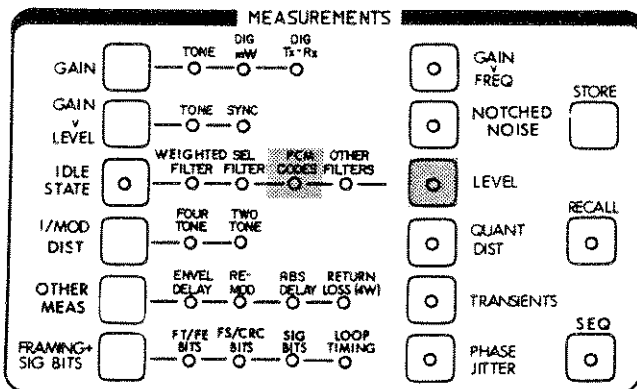
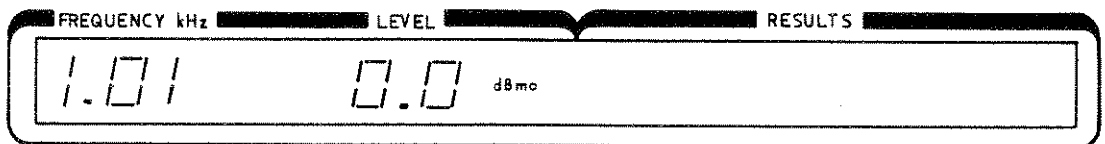









## SECTION IV MEASUREMENTS

### 4-1 INTRODUCTION

4-2 This section contains both measurement information and setting up information which may be required before running measurements.

4-3 The section comprises three parts:

#### 1 SETTING UP THE INSTRUMENT CONFIGURATION

(Operating mode, Interface setting, PCM format, Framing and signalling and background PCM)

#### 2 MEASUREMENT INFORMATION

(Details of individual measurements)

#### 3 SETTING UP THE MEASUREMENT CONFIGURATION

(Parameter selection, Store and recall, Interface default parameters and Measurement sequences)

4-4 The following table lists the contents of this section:

### SETTING UP THE INSTRUMENT CONFIGURATION

OPERATING MODES  
 INTERFACE SETTINGS  
 ANALOG TRANSMIT INTERFACE SETTING  
 Analog Transmitter Impedance  
 Analog Transmitter TLP  
 ANALOG RECEIVE INTERFACE SETTING  
 Analog Receiver Impedance  
 Analog Receiver TLP  
 DIGITAL TRANSMIT INTERFACE SETTING  
 Synthesised or Thru PCM  
 Digital Transmit Timeslot Selection  
 DIGITAL RECEIVE INTERFACE SETTING  
 Terminated or Monitor Input  
 Digital Receive Timeslot Selection  
 PCM FORMAT  
 Signalling  
 Code  
 Frame Format  
 SETTING FRAMING AND SIGNALLING BITS  
 SETTING BACKGROUND PCM  
 TIMESLOT TRANSALATION

### MEASUREMENT INFORMATION

MEASUREMENTS  
 Measurement Groups  
 Measurement Selection  
 Table of Measurements  
 INDIVIDUAL MEASUREMENT INFORMATION

**SETTING UP THE MEASUREMENT CONFIGURATION**

**PARAMETER SELECTION**

Changing Parameters in Multi-point Measurements

Insertion and Deletion of Points

**STORE AND RECALL FUNCTIONS**

STORE AND RECALL WITH FRAMING SIGNALLING AND BACKGROUND PCM

USER DEFINED INTERFACE DEFAULT PARAMETERS

**MEASUREMENT SEQUENCES**

THE COMPLETE NON-VOLATILE MEMORY

**4-5 OPERATING MODES**

4-6 The operator can independently select the analog or digital transmitter and/or the analog or digital receiver. The modes available are therefore:

ANALOG TRANSMIT only	AN Tx
DIGITAL TRANSMIT only	DIG Tx
ANALOG RECEIVE only	AN Rx
DIGITAL RECEIVE only	DIG Rx
ANALOG TRANSMIT ANALOG RECEIVE	AN Tx-AN Rx
ANALOG TRANSMIT DIGITAL RECEIVE	AN Tx-DIG Rx
DIGITAL TRANSMIT ANALOG RECEIVE	DIG Tx-AN Rx
DIGITAL TRANSMIT DIGITAL RECEIVE	DIG Tx-DIG Rx

4-7 These modes are selected with the front panel OPERATING MODE keys AN Tx, DIG Tx, AN Rx, DIG Rx. The mode selected is indicated by led indicators on the appropriate key(s). As selection is limited to one transmit mode and one receive mode, selection of one transmitter or receiver automatically switches off the other transmitter or receiver e.g. If AN Tx and AN Rx are on, the selection of DIG Tx will automatically switch AN Tx off.

**4-8 PCM Loopthrough**

4-9 An additional mode of operation is available in DIGITAL TRANSMIT/ DIGITAL RECEIVE, the THRU PCM mode. This mode provides retransmission of the received PCM stream with the ability to insert a digital test signal in the selected timeslot(s). Timeslot translation is available in the THRU PCM mode. Examples of PCM LOOPTHROUGH operation are given in the Measurement Modes and Configurations section of this manual.

**4-10 INTERFACE SETTINGS**

4-11 The interface settings available are as follows:

AN Tx	select	600/900 BALANCED/UNBALANCED,	TRANSMIT TLP (dBr)
AN Rx	select	600/900 BRIDGED/TERMINATED,	RECEIVE TLP (dBr)
DIG Tx	select	SYNTHESISED PCM/THRU PCM,	TRANSMIT TIMESLOT(S)
DIG Rx	select	TERMINATED/MONITOR,	RECEIVE TIMESLOT

**4-12 DEFAULT VALUES OF INTERFACE SETTINGS**

4-13 The selected values of interface settings are stored in non-volatile memory and automatically become new default values.

**4-14 ANALOG TRANSMIT INTERFACE SETTING**

**4-15 Analog Transmitter Impedance**

4-16 Selection of analog transmitter impedance and balanced or unbalanced output is performed by repeatedly pressing the single key in the ANALOG TRANSMIT section of the front panel. Indication of the impedance selected is provided by the three led indicators.

	600Ω	900Ω	BAL
600Ω BALanced	●	○	●
900Ω BALanced	○	●	●
600Ω UNBALanced	●	○	○
900Ω UNBALanced	○	●	○

**4-17 Analog Transmitter TLP (dBr)**

4-18 The analog transmitter TLP (dBr) setting is enabled with the I/FACES Tx TLP/T-SLOT key. When the analog transmitter is selected, the I/FACES Tx TLP key automatically enables SET LEVEL and the ← →↑↓ keys may be used to set the required TLP.

**4-19 ANALOG RECEIVE INTERFACE SETTING**

**4-20 Analog Receiver Impedance**

4-21 Selection of analog receiver impedance and bridged or terminated input is performed by repeatedly pressing the single key in the ANALOG RECEIVE section of the front panel. Indication of the impedance selected is provided by the three led indicators.

	600Ω	900Ω	BRIDGED
600Ω terminated	●	○	○
900Ω terminated	○	●	○
600Ω BRIDGED	●	○	●
900Ω BRIDGED	○	●	●

**4-22 Analog Receiver TLP (dBr)**

4-23 The analog receiver TLP (dBr) setting is enabled with the I/FACES Rx TLP/T-SLOT key. When the analog receiver is selected, the I/FACES Rx TLP key automatically enables SET LEVEL and the ← →↑↓ keys may be used to set the required TLP.

**4-24 DIGITAL TRANSMIT INTERFACE SETTING**

**4-25 Synthesised or Thru PCM**

4-26 Selection of synthesised (internally generated) or thru (as received) PCM is performed by toggling the single key in the DIGITAL TRANSMIT section of the front panel. Indication of the mode selected is provided by a single indicator on the key.

SYNTHesised PCM	●
THRU PCM	○

NOTE: THRU PCM is required if TIMESLOT TRANSLATION is to be selected.

**4-27 Digital Transmit Timeslot Selection**

4-28 Selection of the timeslot under test is enabled with the I/FACES Tx TLP/T-SLOT key. When the digital transmitter is selected, the I/FACES Tx T-SLOT key automatically enables Tx timeslot selection with the ↑↓ keys. The timeslot(s) selected are indicated on the TIMESLOT display in the DIGITAL TRANSMIT section of the front panel. The ↑↓ keys step the display through the available range.

1	
:	
:	individual timeslots
:	
24	
1..24	all timeslots
-1	all timeslots except timeslot 1
:	:
:	:
-24	all timeslots except timeslot 24

**4-29 DIGITAL RECEIVE INTERFACE SETTING**

**4-30 Terminated or MONitor Input**

4-31 Selection of terminated or monitor input is performed by toggling the single key in the DIGITAL RECEIVE section of the front panel. Indication of the mode selected is provided by a single indicator on the key. The MONitor input provides 20dB gain.

TERMinated	●
MONitor	○

**4-32 Digital Receive Timeslot Selection**

4-33 Selection of the timeslot under test is enabled with the I/FACES Rx TLP/T-SLOT key. When the digital receiver is selected, the I/FACES Rx T-SLOT key automatically enables Rx timeslot selection with the  $\uparrow\downarrow$  keys. The timeslot selected is indicated on the TIMESLOT display in the DIGITAL RECEIVE section of the front panel. The  $\uparrow\downarrow$  keys step the display through the available range.

```

1
:
:   individual timeslots
:
24

```

**4-34 SET PCM FORMAT**

4-35 The PCM format is set with rear panel switches. The format selected applies to both DIG Tx and DIG Rx. The selection available is as follows:

Signalling	CAS CCS	Channel Associated Signalling Common Channel Signalling
Code	AMI (AZS) B8ZS	Alternate Mark Inversion with All Zeros Suppression (Zero Code Suppression) Binary 8 Zeros Suppression
Frame Format	FT FE	normal frame (DS1) extended super frame (extended DS1)

**4-36 SETTING FRAMING AND SIGNALLING BITS**

4-37 Framing and signalling bits can be selected either for measurements on the framing and signalling bits themselves or as the framing and signalling bits to be used in the digital output PCM stream with the measurement signal.

4-38 For this reason the "default" framing and signalling bits are not default parameters in the normal sense. The default condition is set by selecting the required bits on the display and pressing STORE. The selected bits are stored in the non-volatile "default parameters" memory and will automatically be selected at the next switch on. If framing and signalling bits are displayed and changed and the RECALL key is pressed, the currently displayed bits are lost and the "default" bits are recalled. Details of the framing and signalling bits are given in the MEASUREMENTS SECTION.

NOTE: When the appropriate "MEASUREMENT" has been selected the bits are presented on the RESULTS display and are automatically enabled for change with the  $\leftarrow \rightarrow \uparrow\downarrow$  keys.

4-39 The following figure shows the relationship between the framing and signalling bits and the non-volatile memory.

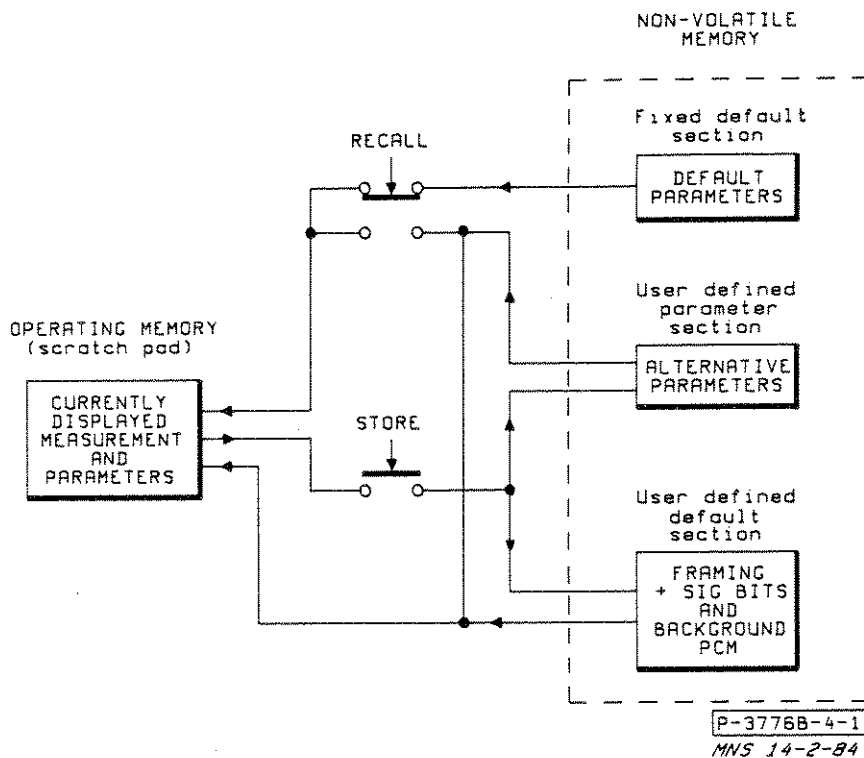

#### 4-40 SET BACKGROUND PCM

4-41 The background PCM comprises a pair of codes alternating in groups of 4. The codes are programmable and, when stored, become the new default state.

4-42 The procedure for selecting background PCM is as follows:

- Select the DIG Tx-Rx mode to display the first code
- Use SET LEVEL and  $\leftarrow \rightarrow \uparrow \downarrow$  to set the first code
- Press NEXT PARAM to display the second code
- Use SET LEVEL and  $\leftarrow \rightarrow \uparrow \downarrow$  to set the second code
- Press STORE to set these codes as new background PCM

#### 4-43 TIMESLOT TRANSLATION

4-44 For measurements on 2 wire systems timeslot translation, between the digital receiver input and the digital transmitter output, can be performed. The content of timeslot  $n$ , where  $n$  is an odd number, is exchanged with the content of timeslot  $n+1$ . The content of timeslot  $n$ , where  $n$  is an even number, is exchanged with the content of timeslot  $n-1$ . The pairs of timeslots which exchange contents are therefore: 1 and 2, 3 and 4, 5 and 6 . . . 23 and 24.

NOTE: TIMESLOT TRANSLATION requires THRU PCM selection.

## Index to Measurement Information and Operating Modes

MEASUREMENT	TYPE	A-A	A-D	D-A	D-D	AN Tx only	DIG Tx only	AN Rx only	DIG Rx only
GAIN(Tone)	SP	8	8	8	8	8	8	8	8
GAIN(Digital mW)	SP			8	8		8	8	8
GAIN(Digital Tx-Rx)	SP				9		9		9
GAIN v FREQUENCY	MP+R	10	10	10	10	10	10	10	10
GAIN v LEVEL(Tone)	MP+R	11	11	11	11	11	11	11	11
GAIN v LEVEL(SYNC)	MP+R			12	12		12	12	12
NOTCHED NOISE	SP	13	13	13	13	13	13	13	13
IDLE STATE									
(Weighted Filter)	SP	13	13	13	13	13	13	13	13
(Selective Filter)	SP	14	14	14	14	14	14	14	14
(PCM Codes)	SP		14		14	14	14		14
(Other Filters)	SP	15	15	15	15	15	15	15	15
LEVEL									
(Weighted Filter)	SP	16	16	16	16	16	16	16	16
(Selective Filter)	SP	17	17	17	17	17	17	17	17
(PCM Codes)	SP		18		18	18	18		18
(Other Filters)	SP	19	19	19	19	19	19	19	19
INTERMODULATION									
(4 Tone)	*	20	20	20	20	20	20	20	20
(2 Tone)	SP	21	21	21	21	21	21	21	21
QUANTISING DISTORTION	MP	22	22	22	22	22	22	22	22
ENVELOPE DELAY	*	23	23	23	23				
RE-MODULATION	CONT	25	25						
ABSOLUTE DELAY	SP	26	26	26	26				
RETURN LOSS (4W)	SP	27	27	27	27	27	27	27	27
TRANSIENTS	TIMED	28	28	28	28	28	28	28	28
FT BITS normal frame	CONT						31		31
FE BITS extended frame	CONT						31		31
FS BITS	CONT						31		31
CRC BITS	CONT						32		32
SIG BITS	CONT						32		32
LOOP TIMING	CONT				44				
PHASE JITTER	CONT	33	33	33	33	33	33	33	33

The numbers in the table refer to pages in Section 4 e.g. GAIN (Tone) information is on Page 4-8.

TYPE SP = SINGLE POINT, MP = MULTI POINT, \* = SPECIAL CASE, SEE TEXT MP+R = MULTI-POINT WITH A REFERENCE POINT, CONT = CONTINUOUS

**4- 52 GAIN TONE**

4- 53 The gain of the system under test is measured using a single tone stimulus and rms responding selective detector.

Tx-Rx modes	point(s)	variables	results
all	single	frequency level	1 in dB

DISPLAYS:	Initial,	measurement frequency	measurement level
		D.DDkHz	±DD.DdBm0
	Default values,	1.01	0.0

	Results,	measurement frequency	measurement level	result
		D.DDkHz	±DD.DdBm0	±DD.DDdB

**4- 54 GAIN DIG mW**

4- 55 The D-A or D-D gain of the system under test is measured at 1kHz using the CCITT defined codes as the stimulus and an rms responding selective detector.

Tx-Rx modes	point(s)	variables	results
AN Tx prohibited	single	none	1 in dB

DISPLAYS:	Initial,	measurement frequency	measurement level
		1.00kHz	0.0dBm0

	Results,	measurement frequency	measurement level	result
		1.00kHz	0.0dBm0	±DD.DDdB



**4- 56 DIGITAL Tx-Rx**

4- 57 A pair of codes, alternating in groups of 4, i.e. at approximately 1kHz, is transmitted in the PCM stream. The peak codes in the received timeslot are detected during the measurement period. Digital Tx-Rx can be used to set up quiet codes. If the values selected are STORED they become the codes automatically selected for background codes where appropriate.

Tx-Rx modes	point(s)	variables	results
analog prohibited	single	Tx code pair	peak +ve code peak -ve code

DISPLAYS: Initial, measurement frequency, measurement level

NEXT PARAM  $\pm$ DDD  
 $\pm$ DDD

Default as selected values, and stored 0 factory preset  
 -0 values

Results, measurement frequency, measurement level, result  
 $\pm$ DDD  $\pm$ DDD

4- 58 GAIN v FREQUENCY

4- 59 The gain of the system under test is measured at each of the selected frequencies relative to the gain at the reference frequency. The measurement is made via a selective filter and an rms responding detector. When calibration corrections are required for the different frequencies in the mask, they are generated as required. The reference point is measured once, at the start of the measurement, in the RUN mode, and with each point in the REPEAT mode.

Tx-Rx modes	point(s)	variables	results
all	30 max	reference level, reference frequency, measurement frequency, no of points	one per point, max 30, in dB
DISPLAYS:	Initial,	reference frequency	reference level
		D.DDkHz	±DD.DdBm0
NEXT PARAM		measurement frequency	measurement level
:		D.DDkHz	(= ref level) Pt 1 in N
:			:
:			:
NEXT PARAM			Pt N in N
Default values,	reference frequency	reference level	
	1.01	0.0	
	measurement frequency	measurement level	
	0.21	0.0	Pt 1 in 9
	0.31	0.0	2 in 9
	0.61	0.0	3 in 9
	1.21	0.0	4 in 9
	1.81	0.0	5 in 9
	2.39	0.0	6 in 9
	2.99	0.0	7 in 9
	3.39	0.0	8 in 9
	3.59	0.0	9 in 9
Results,	measurement frequency	measurement level	result
	D.DDkHz	±DD.DdBm0	±DD.DDdB

4- 60 GAIN v LEVEL TONE

4- 61 The gain of the system under test is measured at each of the selected levels using a single tone stimulus and rms responding detector. The reference point is measured once, at the start of the measurement, in the RUN mode, and once before each run in the REPEAT mode.

Tx-Rx modes	point(s)	variables	results
all	30 max	reference level, reference frequency, measurement levels, no of points	one per point, max 30, in dB

DISPLAYS:	Initial,	reference frequency	reference level	
		D.DDkHz	±DD.DdBm0	
NEXT PARAM		measurement frequency	measurement level	
:		(= ref frequency)	±DD.DdBm0	Pt 1 in N
:				:
:				:
:				:
NEXT PARAM				Pt N in N

Default values	reference frequency	reference level	
	1.01	-10.0	
	measurement frequency	measurement level	
	1.01	3.0	Pt 1 in 8
	1.01	0.0	2 in 8
	1.01	-10.0	3 in 8
	1.01	-20.0	4 in 8
	1.01	-30.0	5 in 8
	1.01	-40.0	6 in 8
	1.01	-50.0	7 in 8
	1.01	-55.0	8 in 8

Results,	measurement frequency	measurement level	result
	D.DDkHz	±DD.DdBm0	±DD.DDdB

4- 62 GAIN v LEVEL 2kHz SYNC

4- 63 The gain of the decoder under test is measured at each of the selected code levels relative to the reference code, using a digital signal, +0, +CODE, -0, -CODE. The received signal is passed through a 2kHz centre frequency selective filter and detected using an rms detector. The reference point is measured once, at the start of the measurement, in the RUN mode, and once before each run in the REPEAT mode.

Tx-Rx modes	point(s)	variables	results
AN Tx prohibited	30 max	reference code, measurement codes, no of points	one per point, max 30, in dB
DISPLAYS: Initial,	reference frequency	reference code	
	2.00kHz	±DDD code	
NEXT PARAM	measurement frequency	measurement code	
:	2.00kHz	±DDD code	Pt 1 in N
:			:
:			:
:			:
NEXT PARAM			Pt N in N
default values	reference frequency	reference code	
	2.00	92	
	measurement frequency	measurement code	
	2.00	127	Pt 1 in 9
	2.00	111	2 in 9
	2.00	95	3 in 9
	2.00	79	4 in 9
	2.00	63	5 in 9
	2.00	47	6 in 9
	2.00	31	7 in 9
	2.00	15	8 in 9
	2.00	1	9 in 9
Results,	measurement frequency	measurement code	result
	2.00kHz	±DDD code	±DD.DDdB

**4- 64 NOTCHED NOISE**

4- 65 A tone at the specified frequency (1010 to 1020 Hz) and level is transmitted. The tone is removed in the receiver by a standard notch filter, the remaining signal is C-message weighted and measured using the rms detector. The result is corrected for the notched bandwidth.

Tx-Rx modes	point(s)	variables	results
all	single	frequency, level	1 in dBrnC0

DISPLAYS: Initial, measurement frequency measurement level  
 D.DDkHz ±DD.DdBm0

Default values, 1.01 0.0

Results,	measurement frequency	measurement level	result
	D DDkHz	±DD.DdBm0	±DDD.DdBmC0

**4- 66 IDLE STATE WEIGHTED FILTER**

4- 67 When AN Tx is selected, the analog transmitter is terminated. When DIG Tx is selected, the quiet code is transmitted in the PCM stream. The receive level is measured via a C-MESSAGE filter at the Rx frequency using an rms detector.

Tx-Rx modes	point(s)	variables	results
all	single	none	1 in dBrnC0

DISPLAYS: Initial, MEAS flag only

Results,	MEAS flag	result
		±DD.DDdBmC0

**4- 68 IDLE STATE SELECTIVE**

4- 69 When AN Tx is selected,the analog transmitter is terminated When DIG Tx is selected,the idle code is transmitted in the PCM stream. The receive level is measured via a selective filter at the Rx frequency using an rms detector.

Tx-Rx modes	point(s)	variables	results
all	single	Rx frequency	l in dBm0

DISPLAYS: Initial, measurement frequency

Default values, D.DDkHz  
1.01

Results, measurement frequency  
D.DDkHz result  
±DD.DDdBm0

**4- 70 IDLE STATE PCM CODES (CODER OFFSET)**

4- 71 When AN Tx is selected,the analog transmitter is terminated When DIG Tx is selected,the quiet code is transmitted in the PCM stream. When DIG Rx only is selected, the background PCM (stored DIG Tx/Rx values)is transmitted. The received codes are averaged during the measurement period and the result, the average of 800 codes, is the number of compressed code level steps from the centre of the coding law.

Tx-Rx modes	point(s)	variables	results
AN Rx prohibited	single	quiet code	l in code

DISPLAYS: Initial, MEAS flag only

Results, MEAS flag result  
±DDD code

**4- 72 IDLE STATE OTHER FILTERS**

4- 73 When AN Tx is selected, the analog transmitter is terminated. When DIG Tx is selected, the quiet code is transmitted in the PCM stream. The receive level is measured via the chosen filter using an rms detector.

Tx-Rx modes	point(s)	variables	results
all	single	quiet code Rx filter A=3kHz B=dc block high pass C=4.1kHz high pass (AN Rx only)	1 in dBm0
DISPLAYS: Initial, Rx filter			
Default			
values. fil A			
Results, filter _			result
			±DD.DDdBm0

**4- 74 LEVEL MEASUREMENTS USING THE AUXILIARY INPUT**

4- 75 Level measurements may be performed using either the internally generated signal or by using an external source applied to the rear panel AUXiliary I/P. The auxiliary input signal is routed either to the selected channel(s) for digital output, or to the analog output by pressing the DELETE key when the LEVEL measurement has been selected.

4- 76 The auxilliary input TLP is -16dB. The analog transmit output level can be varied by suitable selection of the TLP setting. The digital transmitter output is band limited to 3.6kHz.

4- 77 When the AUX I/P is used, the SET FREQ and SET LEVEL controls are inoperative and the results output will not contain transmitted frequency and level information.

4- 78 As autoranging takes place on the receiver input in this mode, it is not suitable for communication over the line under test. Communication over the test path (AUX I/P to MON O/P) is achieved by selecting OPERATING MODE and TIMESLOT, pressing SELF TEST, selecting Pt 22 and pressing RUN. In this mode autoranging does not occur and compensation is made for the AUX I/P TLP.

4- 79 Other details are the same as for level measurements using the internally generated source.

**4- 80 LEVEL MEASUREMENTS USING THE INTERNALLY GENERATED SOURCE**

**4- 81 LEVEL WEIGHTED FILTER**

4- 82 A tone is transmitted at the specified frequency and level and the received level is measured through a C-MESSAGE filter using an rms responding detector.

Tx-Rx modes	point(s)	variables	results
all	single	Tx frequency Tx level	1 in dBmC0

DISPLAYS:

Initial,	Tx frequency	Tx level
	D.DDkHz	±DD.DdBm0
Default values,	1.01	0.0

Results,	Tx frequency	Tx level	result
	D.DDkHz	±DD.DdBm0	±DD.DDdBmC0

For AUXILIARY I/P information see LEVEL MEASUREMENTS USING AUXILIARY INPUT Page 4-15.



**4- 83 LEVEL SELECTIVE**

4- 84 A tone at the specified frequency and level is transmitted and the received level is measured through a selective filter at the receive frequency using an rms responding detector.

Tx-Rx modes	point(s)	variables	results
all	single	Tx frequency Tx level Rx frequency	1 in dBm0

DISPLAYS: Initial, Tx frequency Tx level  
D.DDkHz ±DD.DdBm0

NEXT PARAM Rx frequency  
D.DDkHz

default values 1.01 0.0  
1.01

Results, Rx frequency result  
D.DDkHz ±DD.DDdBm0

For AUXILIARY I/P information see LEVEL MEASUREMENTS USING AUXILIARY INPUT Page 4-15.

4- 85 LEVEL PCM CODES

4- 86 A tone is transmitted at the specified frequency and level and the peak codes received during the gating period are measured.

Tx-Rx modes	point(s)	variables	results
AN Rx prohibited	single	Tx frequency Tx level	1 code pair

DISPLAYS:

Initial,	Tx frequency	Tx level
	D.DDkHz	±DD.DdBm0
Default values,	1.01	0.0

Results,	Tx frequency	Tx level	result
	D.DDkHz	±DD.DdBm0	±DDD ±DDD

For AUXILIARY I/P information see LEVEL MEASUREMENTS USING AUXILIARY INPUT Page 4-15.

4- 87 LEVEL OTHER FILTERS

4- 88 A tone is transmitted at the specified frequency and level and the received level is measured through the selected filter using an rms responding detector. After the measurement has been selected, the NEXT PARAM key is used to select the required filter.

Tx-Rx modes	point(s)	variables	results
all	single	Tx frequency Tx level Rx filter A=3kHz B=dc block high pass C=4.1kHz high pass (AN Rx only)	1 in dBm0

DISPLAYS: Initial, Tx frequency Tx level  
D.DDkHz ±DD.DdBm0

NEXT PARAM filter \_

default values 1.01 0.0  
filter A(3kHz)

Results, Tx frequency Tx level result  
D.DDkHz ±DD.DdBm0 ±DD.DDdBm0

For AUXILIARY I/P information see LEVEL MEASUREMENTS USING AUXILIARY INPUT Page 4-15.

**4- 89 INTERMOD DISTORTION 4 TONE**

4- 90 The 4 tone intermod measurement takes place in two parts:

NOTE: all levels are measured using an rms detector.

1 Two tones at 857 and 863Hz are combined and transmitted at a level equal to the measurement level. The noise received in three bands centered around 520,2240 and 1900Hz is measured to provide a correction figure for the idle noise of the system at the second order bands and third order band in the second part of the measurement.

2 Four tones at 857, 863, 1372 and 1388Hz are combined and transmitted at the measurement level. The level of the total received signal is measured through a flat filter. The levels at the second and third order product bands (520, 2240 and 1900Hz) are measured separately. The average level of the second order products (520 and 2240Hz) and the level of the third order product (1900Hz) relative to the total power received are calculated using the idle noise correction measured in part 1.

4- 91 The second order product is automatically displayed as the result. The NEXT PARAM and PREVIOUS PARAM keys will toggle the results display between the second and third order products.

4- 92 In the REPEAT mode the second part of the measurement is repeated, the idle noise correction figure obtained at the start of the measurement is reused for each repeat.

Tx-Rx modes	point(s)	variables	results
all	single	measurement level	2 in dB

DISPLAYS: Initial, measurement frequency, measurement level

Default values, fixed 860+-3Hz, 1380+-8Hz

-DD.DdBm0

-3.0

Results,	measurement frequency	measurement level	result
NEXT PARAM		-DD.DdBm0 2nd	-DDD.DdB
		-DD.DdBm0 3rd	-DDD.DdB

4- 93 INTERMOD 2 TONE

4- 94 The selectable frequencies f1 and f2 are combined to produce the transmitted signal at the measurement level. The levels of f1 and 2f1-f2 are measured using selective filters and an rms detector. The measurement result is the level of 2f1-f2 relative to the level of f1.

Tx-Rx modes	point(s)	variables	results
all	single	frequencies f1 and f2 level	1 in dB

Note: frequencies f1 and f2 must not be within 150Hz of each other or of 2f1-f2.  
2f1-f2 must be in the range 200 to 3900Hz.

DISPLAYS: Initial, frequency f1 measurement level

D.DDkHz ±DD.DdBm0

NEXT PARAM frequency f2 measurement level  
(=PREVIOUS PARAM)  
D.DDkHz

Default values, (f1) 0.47 -4.0  
(f2) 0.32

Results, frequency measured measurement level result

D.DDkHz ±DD.DdBm0 ±DD.DdB

4- 95 QUANTIZING DISTORTION TONE

4- 96 The noise level of the system under test is measured relative to the received level of the stimulating tone. The frequency range of the stimulating tone is 1010 to 1020Hz. The measurement frequency range is 990 to 1020Hz. The received signal is C-message weighted and its level is measured using the rms responding detector. The tone is then removed by the standard notch filter, the remaining noise is C-message weighted and the level of the weighted noise is measured using the rms detector. The result (SIGNAL + NOISE)/NOISE is corrected for the notched bandwidth.

Tx-Rx modes	point(s)	variables	results
all	30 max	measurement levels, measurement frequency, no of points	one per point, max 30 in dB (see above)
DISPLAYS:	Initial,	measurement frequency	measurement level
		D.DDkHz	±DD.DdBm0
NEXT PARAM		measurement frequency	measurement level Pt 1 in N
:		(= Pt 1 frequency)	±DD.DdBm0 Pt 2 in N
:			
:			
:			
NEXT PARAM			Pt N in N
Default values,	measurement frequency	measurement level	
	1.01	0.0	Pt 1 in 6
	1.01	-10.0	2 in 6
	1.01	-20.0	3 in 6
	1.01	-30.0	4 in 6
	1.01	-40.0	5 in 6
	1.01	-45.0	6 in 6
Results,	measurement frequency	measurement level	result
	D.DDkHz	±DD.DdBm0	±DD.DdB

**4- 97 ENVELOPE DELAY DISTORTION (optional measurement)**

4- 98 The instrument is designed to transmit and receive signals which conform to BSTR41009. There are three possible configurations for envelope delay distortion measurement:

- 1 Loop-back, measuring the combined go and return paths
- 2 Single path, using another instrument at the far end set to REMOD AN Tx, to return the received signal remodulated on a fixed frequency carrier (see REMOD).
- 3 End to end, on a homochronous system (i.e. a system in which corresponding significant instants of the clock have a constant but uncontrolled phase relationship). The clock of the transmitting instrument must also be system clock. This may be achieved by using the rear panel EXT CLOCK INPUT. This mode can be used on a non-synchronous system but the accuracy is impaired by an amount dependent on the clock skew. [100ppm → 100us/(second ref to meas separation)].

4- 99 The receiver compares the phase of the envelopes of both the reference and measurement signals with an internal reference and then compares the two results obtained to produce the envelope delay distortion result. Similarly the amplitudes of the envelopes are compared to produce the relative attenuation result. This method applies a correction for the internal attenuation and EDD of the 3776. When the measurement is running the measurement parameters are displayed. The received reference frequency can be displayed by pressing the NEXT PARAM key. The PREVIOUS PARAM key will restore the measurement frequency display.

4-100 The result produced at the reference frequency is intended for use as a settling time indicator, in particular when there is a remote remodulating instrument. The reference frequency can be repeated until the result approaches zero, to indicate that the network including the remote instrument has settled.

4-101 The measurement range for envelope delay is -3 to +9ms. Result displays beyond this range are "wrapped around" as follows:

RESULT DISPLAYED ms		+8 -3.. 0		+9 -2.....
ENVELOPE DELAY ms		-4 -3.. 0		+9 +10.....

Tx-Rx modes	point(s)	variables	results
all	30 max	reference level, reference frequency, measurement frequencies, no of points.	one pair per point max 30 in dB and ms

DISPLAYS: Initial, reference frequency reference level

D.DDkHz ±DD.DdBm0

NEXT PARAM	measurement frequency	measurement level	
:	D.DDkHz	(=reference level)	Pt 1 in N
:			:
:			:
:			:
NEXT PARAM			Pt N in N

Default values,	reference frequency	reference level	
	1.81	-5.0	
	measurement frequency	measurement level	
	0.51	-5.0	Pt 1 in 13
	0.61	-5.0	2 in 13
	0.81	-5.0	3 in 13
	1.01	-5.0	4 in 13
	1.21	-5.0	5 in 13
	1.41	-5.0	6 in 13
	1.61	-5.0	7 in 13
	1.81	-5.0	8 in 13
	2.01	-5.0	9 in 13
	2.21	-5.0	10 in 13
	2.41	-5.0	11 in 13
	2.59	-5.0	12 in 13
	2.79	-5.0	13 in 13

Results,	measurement frequency	measurement level	result
	D.DDkHz	±DD.DdBm0	±D.DdB±D.DDms



## 4-102 REMOD

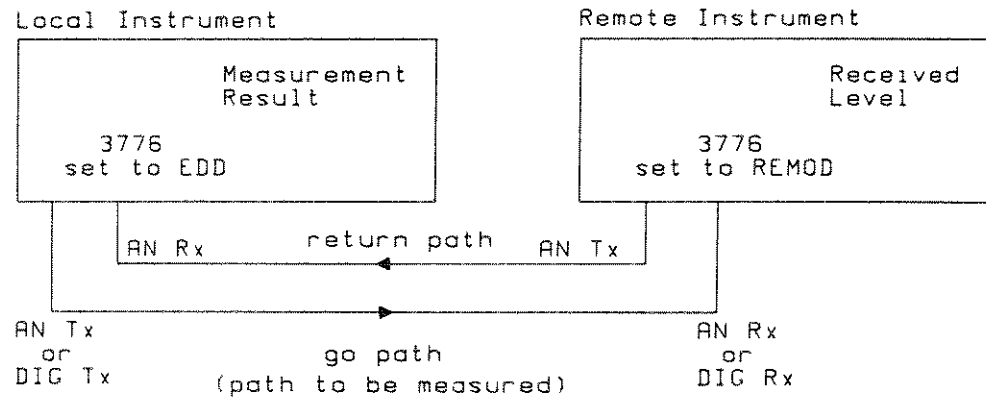

4-103 The remodulation facility is required when the Envelope Delay Distortion of one path of a loop is to be measured.

4-104 The remote instrument, set to REMOD, transmits an analog signal comprising the reference frequency, used as a fixed frequency carrier, modulated with the envelope recovered from the received signal. The remote instrument normally displays the measurement frequency and received level. The reference frequency can be displayed by pressing the NEXT PARAM key and the display returned to measurement frequency with the PREVIOUS PARAM key. REMOD is a "continuous measurement". It is necessary to use the STOP key to exit from this mode.

4-105 The local instrument, set to EDD, operates as for any other EDD measurement except for the operating mode which is limited to AN Rx.

NOTE: Amplitude information is lost during remodulation by the 3776.

4-106 ABSOLUTE DELAY (optional measurement)

4-107 A carrier at the selected frequency, amplitude modulated with a 83.33Hz sinewave is transmitted. The phase of the envelope of the received signal is compared with an internal reference and the absolute delay is derived. The measurement range is 0 to 12ms. The result display is "wrapped around" for delays beyond this range as follows:

```

                                |
RESULT DISPLAY ms    0.....12|1.....
ABSOLUTE DELAY ms   0.....12|13.....
                                |
    
```

Tx-Rx modes	point(s)	variables	results
Tx only or Rx only prohibited	single	frequency, level	1 in ms

DISPLAYS:	Initial,	reference frequency	measurement level
		D.DDkHz	±DD.DdBm0
	Default values,	1.80	0.0

Results,	measurement frequency	measurement level	result
	D.DDkHz	±DD.DdBm0	±DD.DDms

**4-108 RETURN LOSS (4 W)**

4-109 A signal conforming to the BSTR echo return loss requirements is transmitted at the selected level. The received signal is routed via an ERL wideband filter to the rms detector.

Tx-Rx modes	point(s)	variables	results
all	single	level	l in dB
DISPLAYS: Initial,		measurement level	
		±DD.DdBm0	
Default values,		-10.0	
Results,		measurement level	result
		±DD.DdBm0	±DD.DDdB

**4-110 DIALLING**

4-111 Dialling is performed in the same way as a measurement. Although dialling can only normally be performed via HP-IB, and is therefore described in the HP-IB section of this manual, it is possible to include dialling in a sequence for manual operation. The dialled digits can be altered by leaving the sequence and using the NEXT/PREVIOUS PARAM keys to display the digit to be changed and changing it with the SET LEVEL and ↑↓ keys. The changed digits will be lost when another measurement or mode is selected. For additional information see Page 6-22.

**4-112 TRANSIENTS (optional measurement)**

4-113 The transmitter produces a holding tone at the selected frequency (1010 to 1020Hz) and level. Gain hits, phase hits, dropouts and impulse counts are measured by the receiver. Dropouts inhibit all other measurements.

**4-114 Selectable Parameters**

4-115 The count rate is selectable:       SLO = 8 counts/second  
  FAST = 100 counts/second

The measurement duration is selectable in units of hours and minutes from 0 hours 01 minute to 9 hours 59 minutes or CONTINUOUS. CONTINUOUS is selected by increasing the duration above 9.59.

**4-116 Gain Hits, Phase Hits and Dropouts**

4-117 Thresholds are displayed using the NEXT PARAM key and are selectable as follows:

- Gain hits.....2,3,4 or 6dB.
- Phase hits..... 5° to 40° in 5° steps.
- Dropouts..... 12dB fixed.

4-118 The signal is routed via a 400 to 1600Hz band limiting filter to level and phase monitors. Falls of greater than 12dB lasting for more than 4ms are detected as dropouts. Level or phase excursions beyond the selected thresholds and lasting for more than 4ms are detected as gain hits and phase hits respectively, except when they occur during dropouts.

**4-119 Impulse Counts (Three Levels).**

4-120 The low threshold is displayed using the NEXT PARAM key and the value is selected. The mid and high thresholds are automatically set to 4 and 8dB respectively above the selected low threshold. The received signal is routed via a C-message filter and a notch filter to level monitors. Excursions above each threshold are counted independently.

4-121 If a power failure occurs, the instrument will recover and continue from the point of interruption when the power is restored. The instrument will display ERROR 45 when power has been restored to indicate that a power failure has occurred during measurement run time. This display will be cleared at the end of the measurement when the result is displayed, or when the NEXT PARAM or PREVIOUS PARAM keys are used during the measurement run. In HP-IB operation, provision is made for power failure indication with the rear panel POWER ON SRQ switch.

Tx-Rx modes	point(s)	variables	results
all	time period meas	hold tone frequency, hold tone level, slow/fast count, measurement time, gain hit threshold, phase hit threshold, impulse count "low" threshold.	6 counts scrolled with NEXT PARAM and PREVIOUS PARAM keys

DISPLAYS: Initial, measurement measurement  
frequency level  
D.DDkHz ±DD.DdBm0

NEXT PARAM	count rate	SLO/FAST	count
NEXT PARAM	duration	DDhrsDDmin	h-min
NEXT PARAM	gain hit threshold	DdB	g hit
NEXT PARAM	phase hit threshold	DD°	p hit
NEXT PARAM	dropout threshold (fixed)	-12dB	d out
NEXT PARAM	impulse count lo threshold	-DDdBm0	I count
	mid	low+4dB	
	high	low+8dB	
	Default values,	1.01	0.0

NEXT PARAM	count rate	SLO	count
NEXT PARAM	duration	00hrs05min	h-min
NEXT PARAM	gain hit threshold	2dB	g hit
NEXT PARAM	phase hit threshold	5°	p hit
NEXT PARAM	dropout threshold	-12dB	d out
NEXT PARAM	impulse count lo threshold	-20dBm0	I count
	mid	low+4dB	
	high	low+8dB	

Results, level result

NOTE: using PREVIOUS PARAM to display count rate or hold tone clears results.

		selected values		
NEXT PARAM	duration	DDhrsDDmin	h-min	D.DD
NEXT PARAM	gain hits	DdB	g hit	DDDD
NEXT PARAM	phase hits	DD°	p hit	DDDD
NEXT PARAM	dropouts	-12dB	d out	DDDD
NEXT PARAM	impulse counts low	-DDdBm0	I count	DDDD
NEXT PARAM	mid	-DD	I count	DDDD
NEXT PARAM	high	-DD	I count	DDDD

4-122 FRAMING and SIGNALLING BITS

4-123 MODES DIG Tx or DIG Rx only

4-124 The default framing and signalling bits are under the control of the operator. The store facility,un-like its function with other parameters, sets the currently displayed framing and signalling bits as the new default condition.

NOTE: For PCM inputs the receiver requires:

- Frame Alignment Word 1010101 and
- Frame pattern sequence (ESF) 001011
- Ft CAS Multi-frame Alignment or Signalling framing word 001110

4-125 The received framing and signalling bits are presented on the RESULTS display. The first word detected is displayed and the display is updated each time the detected word differs from the displayed word. The last word detected before loss of alignment is displayed until alignment is regained. When the display changes, there is a short delay before monitoring continues. The rear panel DIG Rx OUTPUT provides a TTL output of the received PCM stream with a data valid signal at appropriate points for the currently selected framing or signalling bits. The frame structure is described in appendix B.

4-126 The following table gives a summary of the modes in which the various framing and signalling bits are available.

BITS	NORMAL FRAME				EXTENDED FRAME			
	CAS		CCS		CAS		CCS	
	DIG Tx	DIG Rx	DIG Tx	DIG Rx	DIG Tx	DIG Rx	DIG Tx	DIG Rx
SIG	SIG	SIG			SIG	SIG		
Ft/Fe	← Ft →				← Fe →			
Fs/CRC	← Fs →					CRC		CRC

**4-127 FT BITS****4-128 DIG Tx**

4-129 The FT bit sequence in the transmitted PCM stream is formed from the selected 6 bits.

**4-130 DIG Rx**

4-131 Displays the received FT bits in groups of 6 bits. The frame order may not be maintained following loss of alignment.

DIG Rx OUTPUT (rear panel) TTL1 1 bit at half frame rate.

**4-132 FE BITS (Extended frame format only)****4-133 DIG Tx**

4-134 The FE bit sequence in the transmitted PCM stream is formed from the selected 6 bits.

**4-135 DIG Rx**

4-136 Displays the received FE bits in groups of 6 bits. The frame order may not be maintained following loss of alignment.

DIG Rx OUTPUT (rear panel) TTL1 1 bit at half frame rate.

**4-137 FS BITS (normal frame, CAS only)****4-138 DIG Tx**

4-139 The Fs bit sequence in the transmitted PCM stream is formed from the selected 6 bits.

**4-140 DIG Rx**

4-141 Displays the received Fs bits in groups of 6 bits in frame order. The frame order may not be maintained following loss of alignment(CAS multi-frame alignment).

DIG Rx OUTPUT (rear panel) TTL1 1 bit at half frame rate.

**4-142 TS SIG BITS**

**4-143 DIG Tx**

4-144 Timeslot Selection. The selected signalling bits can be inserted in all timeslots or in particular timeslot(s) with the default signalling bits in the remaining timeslots as follows:

TIMESLOT(S) SELECTED	TIMESLOT(S) CONTAINING CURRENTLY SELECTED SIG BITS	TIMESLOT(S) CONTAINING DEFAULT SIG BITS
1..24	all	none
1	1	2..24
:	:	:
24	24	1..23
-1	2..24	1
:	:	:
-24	1..23	24

4-145 NORMAL FRAME, CAS. The two bit word comprising bits A and B is selectable. The first bit (A) is allocated to frame 6 and the second bit (B) is allocated to frame 12.

4-146 EXTENDED FRAME (FE), CAS. The four bit word comprising bits A to D is selectable. The first bit (A) is allocated to frame 6, B to frame 12, C to 18 and the last bit (D) to frame 24.

**4-147 DIG Rx**

4-148 The Rx timeslot of interest must be selected.

4-149 The result display is a two or four bit word depending on the selection of normal or extended frame. the words displayed correspond to the words selected in the Tx mode (see above).

DIG Rx OUTPUT (rear panel) TTLI 1 bit at 1/6 frame rate.

**4-150 CRC BITS DIG Rx Fe only**

4-151 The result display is a six bit word comprising the cyclic redundancy code (CRC) bits from frames 2, 6, 10, 14, 18 and 22.

**4-152 LOOP TIMING**

4-153 The instrument provides an indication of loop timing using a pictorial display. The RESULTS display is stationary when the received clock frequency is nominally the same as the transmitted clock frequency. Rotation of the marker indicates a frequency difference and jitter of the marker indicates timing jitter. As the loop timing measurement compares the received clock with the generated clock it is only valid in the DIG Tx-DIG Rx operating mode. Loop timing is a continuous measurement. When loop timing is selected the instrument will continue to operate in the loop timing mode until the STOP key is pressed.



**4-154 PHASE JITTER (optional measurement)**

4-155 The transmitted signal is a 1010Hz tone at the selected level. The settling time required depends on the receiver filter selected, 4 seconds for filter A (fast) or 25 seconds for filter B (slow). The detected jitter is available at the MONITOR OUTPUT for further analysis if required.

PHASE JITTER is a "continuous measurement". It is necessary to use the STOP key to exit from this measurement.

Tx-Rx modes	point(s)	variables	results
all	single	level, Rx filter A=20 to 300Hz B=4 to 300Hz	continuous in degrees pk-pk

DISPLAYS: Initial, measurement frequency, measurement level  
 1.01kHz ±DD.DdBm0

NEXT PARAM fil \_

Default values, 1.01 0.0

NEXT PARAM fil A

Results, measurement frequency, measurement level, result  
 fil \_ ±DD.DdBm0 ±DD.Ddeg p-p

**4-164 Insertion and Deletion of Points**

4-165 Points can be inserted into or deleted from multi-point measurements using the INSERT and DELETE keys. The INSERT key duplicates the currently displayed measurement point which can then be changed to the the parameters required as described above. the DELETE key deletes the currently displayed measurement point.

4-166 The following example shows the steps required to insert a measurement point.

The multi-point measurement in this example is the same 4 point gain v frequency measurement used in the previous example.

	FREQUENCY kHz		LEVEL		RESULTS
1st display is reference.	1.01	ref	0.0	dBm0	
2nd display first meas point obtained with NEXT PARAM key.	0.21	meas	0.0	dBm0	Pt 1 in 4
other displays available with NEXT PARAM key.	0.31	meas	0.0	dBm0	Pt 2 in 4
	0.61	meas	0.0	dBm0	Pt 3 in 4
	1.21	meas	0.0	dBm0	Pt 4 in 4

With Pt 3 in 4 displayed the INSERT key will insert another point with the same parameters. When the frequency is changed, the new point will go to a logical location in the frequency order.

	0.61	meas	0.0	dBm0	Pt 3 in 4
INSERT	0.61	meas	0.0	dBm0	Pt 3 in 5
SET FREQ ↓	0.28	meas	0.0	dBm0	Pt 2 in 5
NEXT PARAM	0.31	meas	0.0	dBm0	Pt 3 in 5

The complete new sequence is now:

	FREQUENCY kHz		LEVEL		RESULTS
	1.01	ref	0.0	dBm0	
	0.21	meas	0.0	dBm0	Pt 1 in 5
	0.28	meas	0.0	dBm0	Pt 2 in 5
	0.31	meas	0.0	dBm0	Pt 3 in 5
	0.61	meas	0.0	dBm0	Pt 4 in 5
	1.21	meas	0.0	dBm0	Pt 5 in 5

4-167 STORE AND RECALL FUNCTIONS

4-168 The selected parameters can be stored in non-volatile memory by pressing the STORE key while they are displayed. The RECALL key can then be used to toggle between the default parameters and the user defined parameters. The following figure shows the operation of the STORE and RECALL functions.

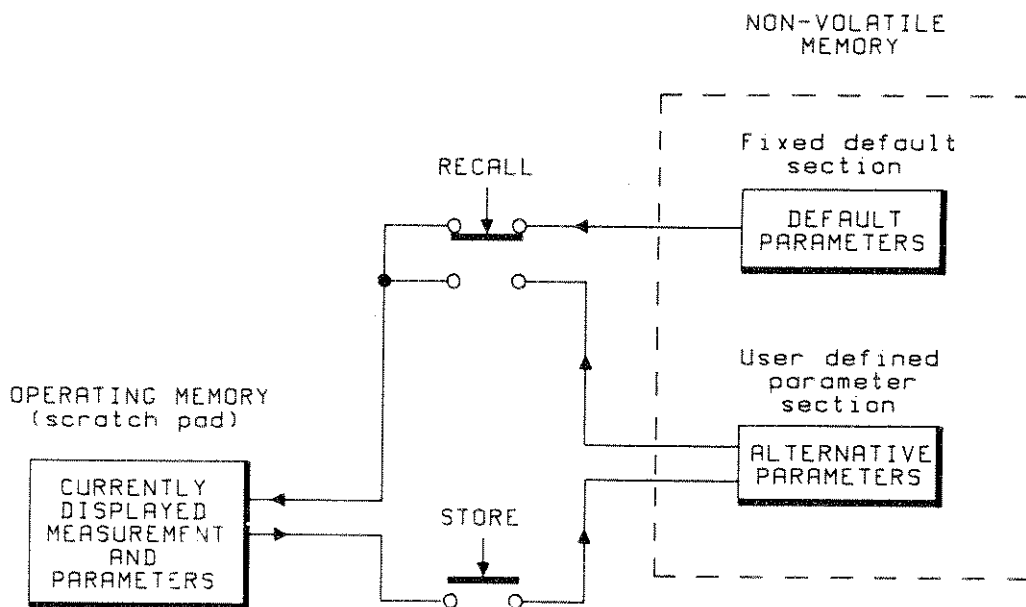

#### 4-173 MEASUREMENT SEQUENCES

4-174 A measurement sequence can be loaded into the non-volatile memory of the instrument using an external controller. The sequence can be run from the front panel of the instrument (without the use of a controller) with the SEQUENCE and RUN keys. The parameters of the measurements in the sequence can be the same as, or different from the default parameters or the user defined stored set. The sequence can comprise up to approximately 50 points depending on the number of parameters which apply to each point.

4-175 The procedure for compiling a sequence is as follows:

- 1 Select the addressable mode and connect a controller to the rear panel HP-IB connector.
- 2 Clear the sequence memory if required by addressing the 3776 and sending the command "CS".
- 3 Press the LOCAL key.
- 4 Set up the first point of the measurement as for manual operation
- 5 Append the first measurement point to the sequence by addressing the 3776 and sending the command "AS".
- 6 Repeat the procedure steps 3 thru 5 for each subsequent measurement point.

4-176 An alternative to steps 3 thru 6 is to set up the measurement points via HP-IB. In this case the whole operation is performed in the remote mode.

4-177 A sequence, stored in the instrument is not intended for running via HP-IB, it is normally run manually from the front panel.

4-178 The sequence is enabled by pressing the SEQ key, and run with either the RUN or S/STEP keys. When sequence operation is enabled, the "on key" indicator comes on, the display flags Pt 1 to indicate the first measurement of the sequence and the MODE and MEASUREMENT indicators show the mode and measurement of that sequence point. The NEXT PARAM and PREVIOUS PARAM keys will scroll the sequence points (measurements) at this stage, producing display flags of Pt 1 to Pt n, the last measurement in the sequence. When the SEQ key indicator is on, the RUN key will run the complete sequence and the S/STEP key will run the currently selected measurement.

4-179 The SEQ key can be used to toggle in and out of the sequence, as indicated with the "on key" indicator. When the SEQ key is used to toggle out of the sequence ("on key" indicator off) the first (or only) parameter display of the selected measurement (sequence point) is displayed. The NEXT PARAM and PREVIOUS PARAM keys will scroll the measurement parameters. At this stage the instrument is no longer in the sequence mode and operates as if the measurement had been selected manually i.e. the parameters can be changed and a measurement run performed with the chosen parameters.

4-180 The chosen parameters can only be inserted in the sequence by the use of a controller. If the sequence is re-selected the original sequence, modes, measurements, and parameters are restored.

4-181 Although the operating modes allowed in sequences are normally limited to loop-back modes, the DIALING "measurement" can be included in the sequence. As with other sequence measurements, it is possible to toggle out of the sequence when dialling is the current point, change the parameters e.g. digits dialled, and run dialling. A complete sequence is performed in the same way as a multi-point measurement. The functions performed on a sequence by the CONTROL keys are the same as those performed on a measurement (see RUNNING MEASUREMENTS).

NOTE: The STOP key aborts the current sequence and returns to the sequence start state.

4-182 The preferred method of running a sequence of measurements remotely is to compile and store it as individual measurements in the controller, making suitable provision for the output of results.

4-183 In general sequence measurements are limited to loopback modes of operation i.e. modes where one instrument is transmitting and receiving, however it is possible to include dialling as part of a sequence. As dialling is an HP-IB only function the dialling information must be entered from a controller.

**4-184 Continuous Measurements In Sequences**

4-185 A sequence run cannot pass a continuous measurement. When one continuous measurement is to be included in a sequence, it should be made the last measurement in the sequence. If TRANSIENTS and one other continuous measurement e.g. PHASE JITTER are to be included in the sequence, the TRANSIENTS measurement should be timed (less than 9hrs 59min) not set to CONT.

4-186 The following figure shows the operation of the SEQUENCE function.

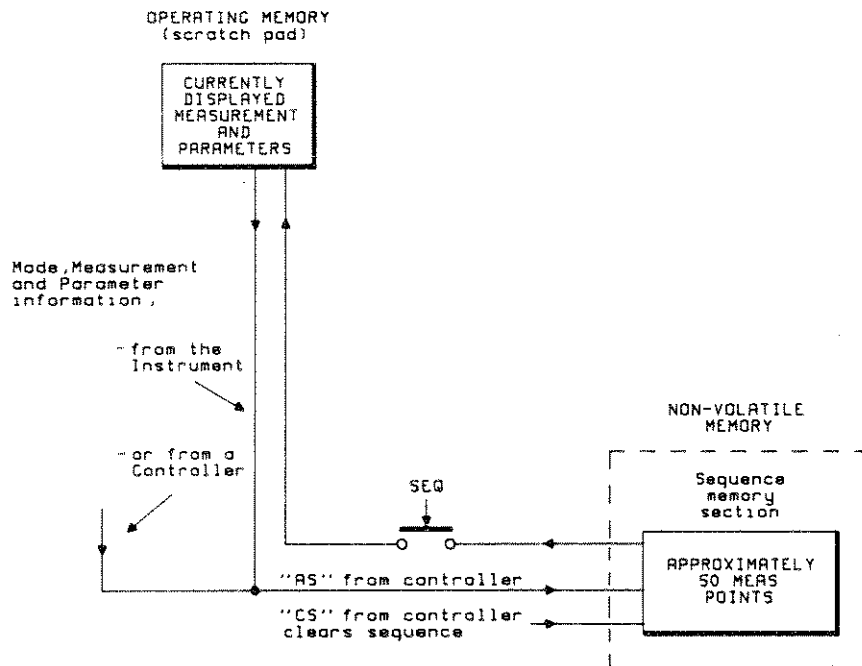

4-187 THE COMPLETE NON-VOLATILE MEMORY

4-188 By combining the facilities of the store/recall function and the sequence function, further facilities can be more readily seen. e.g. The sequence store can be used to hold additional stored parameters.

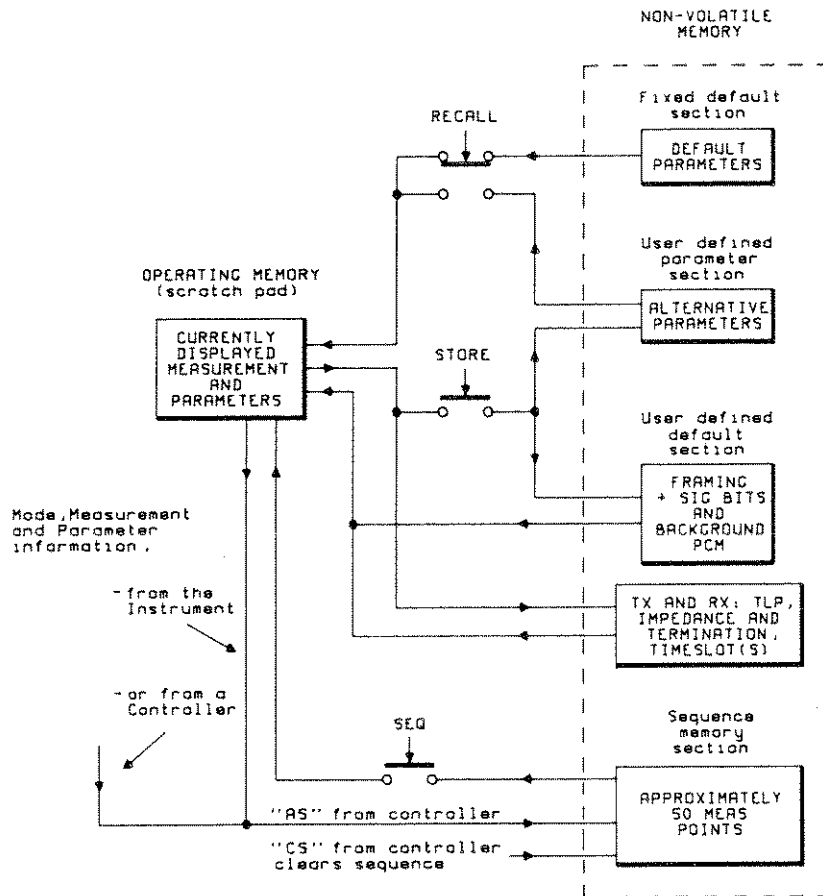







**SECTION V  
MEASUREMENT MODES AND CONFIGURATIONS**

**5- 1 INTRODUCTION**

5- 2 The 3776 is capable of operating in two basic measurement configurations, LOOPBACK or END-TO-END. These configurations include the digital loop-through capability of the instrument. An additional mode (REMOD) is available with ENVELOPE DELAY DISTORTION measurements.

5- 3 The ANALOG or DIGITAL TRANSMITTER and/or the ANALOG or DIGITAL RECEIVER are independently selectable to give complete coverage of the OPERATING MODES available. The table on page 4-8 gives the operating modes available for particular measurements. Invalid modes cannot be selected.

**5- 4 ASSOCIATED EQUIPMENT**

5- 5 In all modes, a hard copy of the measurement result can be obtained by connecting an 80 COLUMN PRINTER (for single point measurements) or an HP-GL PLOTTER (for multi-point measurements) to the rear panel HP-IB connector, see OBTAINING HARD COPY OF MEASUREMENT RESULTS paragraph, 5-26, APPENDIX C Plot Options and Section 2 (The Talk Only Mode).

5- 6 Commands are available to obtain hard copy of the measurement results in the REMOTE mode via HP-IB, see section 6 HP-IB

5- 7 Individual analog voice channels of a PCM terminal can be accessed using an HP 3777A CHANNEL SELECTOR and an HP-IB controller.

5- 8 The following examples show typical, but not all, measurement configurations:

**5- 9 LOOPBACK CONFIGURATIONS**

**5-10 A-D Local Coder Test**

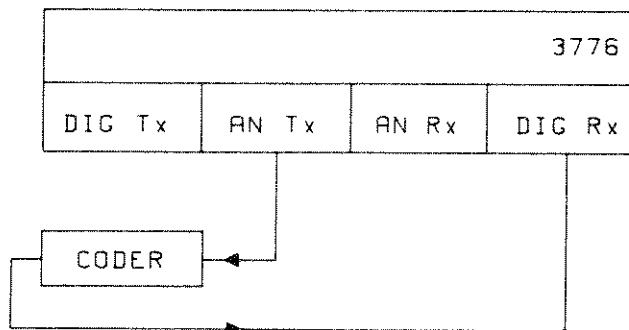

5-11 A-A Local Coder/Decoder Test

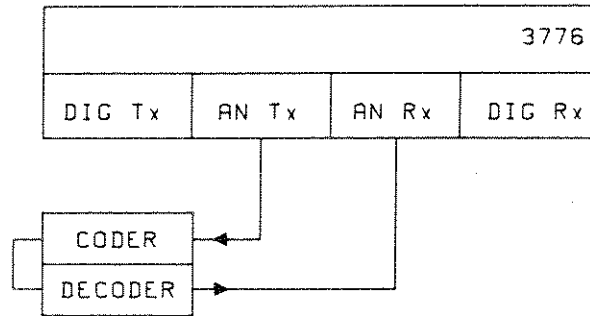

5-12 A-A Local and Remote Coder/Decoder Test

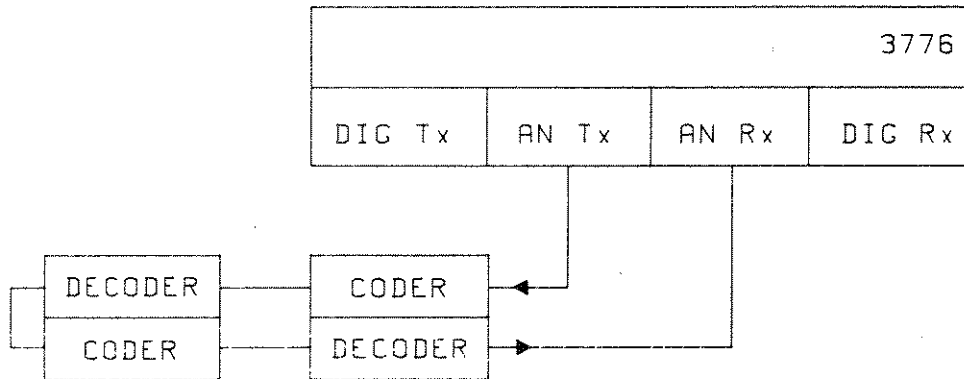

5-13 D-D Remote Coder/Decoder Test

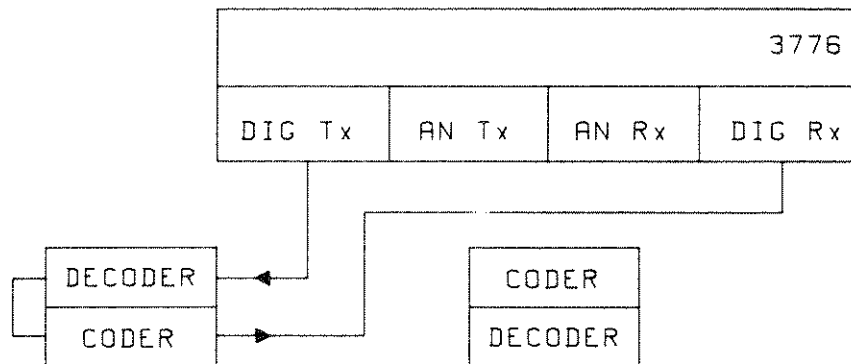

**5-14 Coder/Decoder Test Using Digital Loopthrough**

5-15 This method of connection allows rapid switching between A-A, A-D and D-A operating modes.

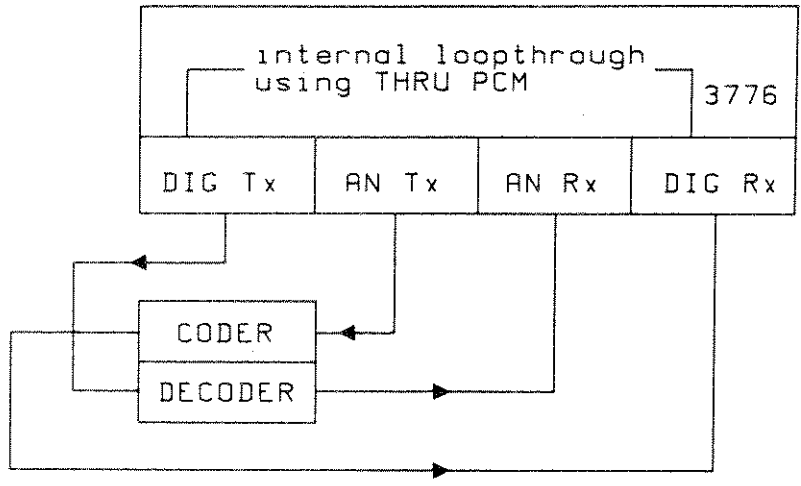

NOTE: The coder must not rely on the 3776 clock.

5-16 PCM Terminal Testing (sequential)

5-17 The HP-IB controller is required for two purposes:

- 1 To control the CHANNEL SELECTOR for routing the analog signals to and from individual voice channels.
- 2 To select the 3776 DIG Tx and DIG Rx timeslots which correspond to the analog channel selected (this will depend on the particular channel/timeslot mapping used) and to run the measurement when the appropriate path has been established.

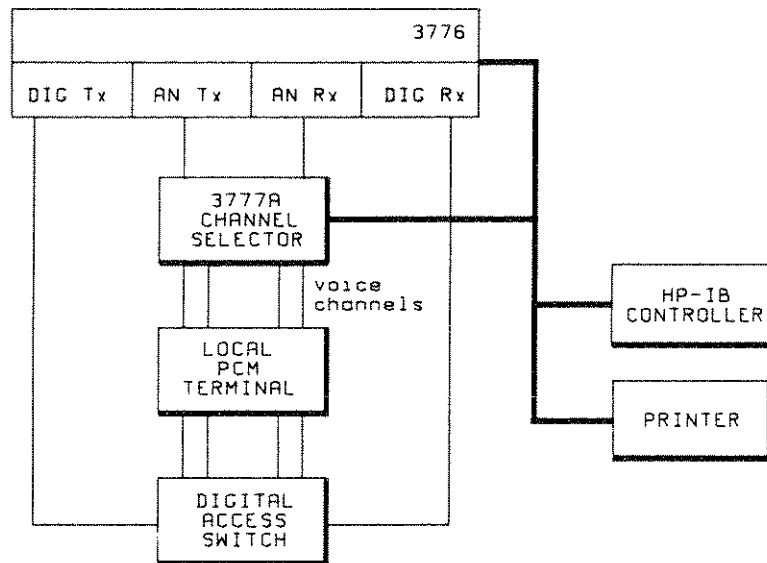

5-18 PCM System Digital Testing (without interrupting traffic)

5- 19 The HP-IB controller is required for two purposes,

- 1 To control the CHANNEL SELECTOR for looping the test signals to return them to the measuring instrument.
- 2 To select the 3776 DIG Tx and DIG Rx timeslots, see figure. and to run the measurement when the appropriate path has been established.

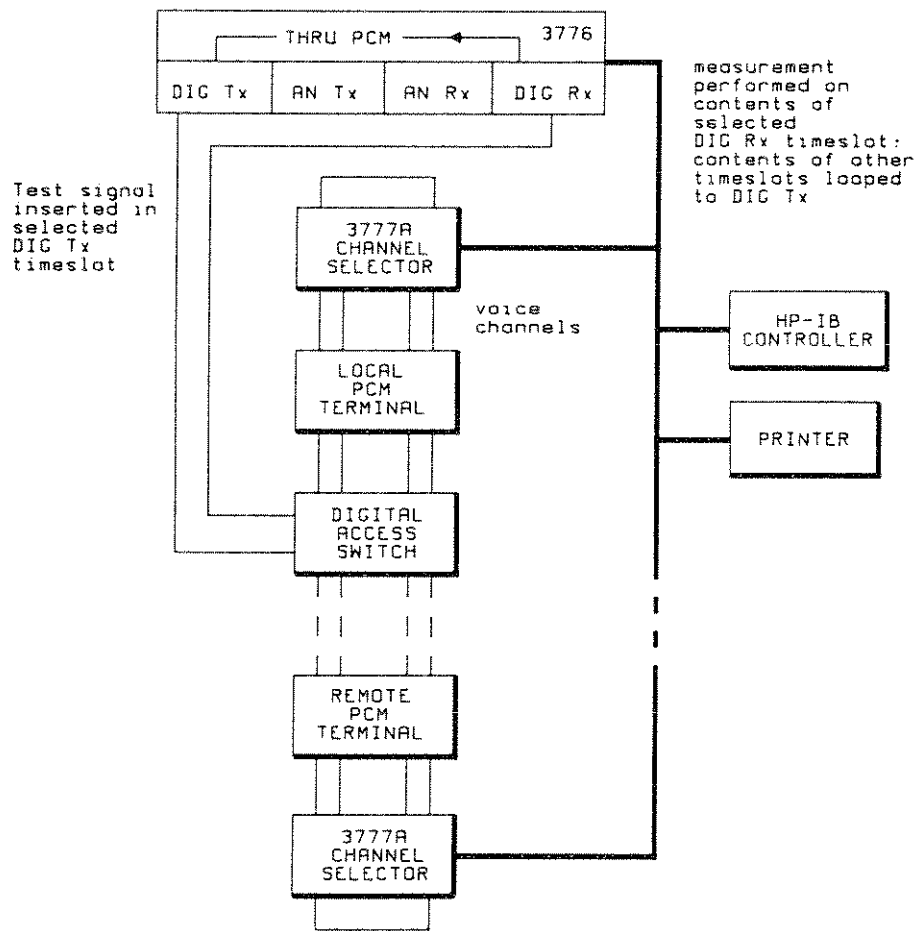

**5-20 Simultaneous Testing of More Than One Timeslot**

5-21 It is possible to cascade a number of instruments using THRU PCM. Each instrument can insert a test signal and make measurements on one timeslot without affecting traffic in the remaining timeslots.

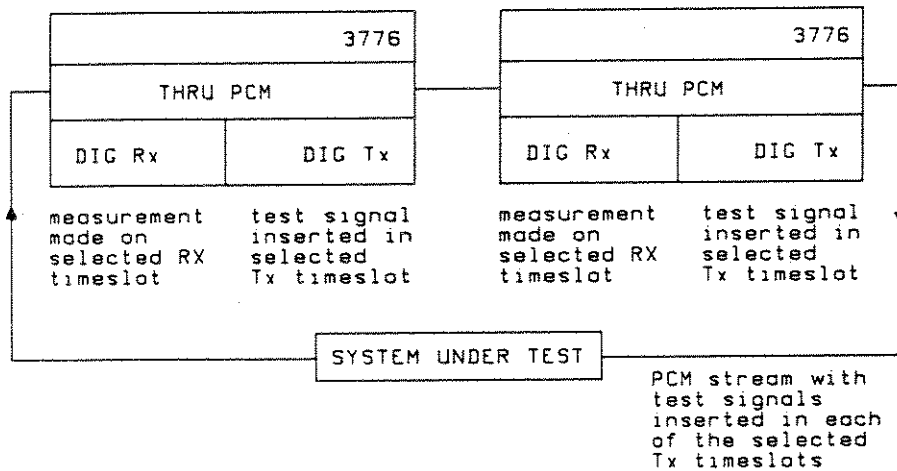

**5-22 END TO END MEASUREMENTS**

5-23 End to end measurements require two instruments, the local instrument providing the stimulus AN Tx or DIG Tx and the remote instrument making the measurement, AN Rx or DIG Rx. For end to end measurements the receiving instrument must initially be set to the reference levels and frequencies selected on the transmitting instrument.

**5-24 Communication Over The Line Under Test**

5-25 Voice communication over the line under test can be achieved by selecting SELF TEST 22. This enables a communication path between the AUXilliary I/P of the transmitting instrument to the MONitor O/P of the receiving instrument.

NOTE: the above technique has an advantage over selecting the AUX I/P, as for a level measurement, as SELF TEST 22 disables the receiver level autorange capability.

The procedure for selecting SELF TEST 22 is as follows:

- Press SELF TEST. The display will show CAL "TEST 1"
- Press PREVIOUS PARAM to scroll the test numbers in reverse sequence, the first display obtained is Pt22 "TEST 22".
- Press RUN.
- TEST 22 is a continuous state. To leave the communication mode press STOP.

5-26 A-A Local Coder/Remote Decoder Test

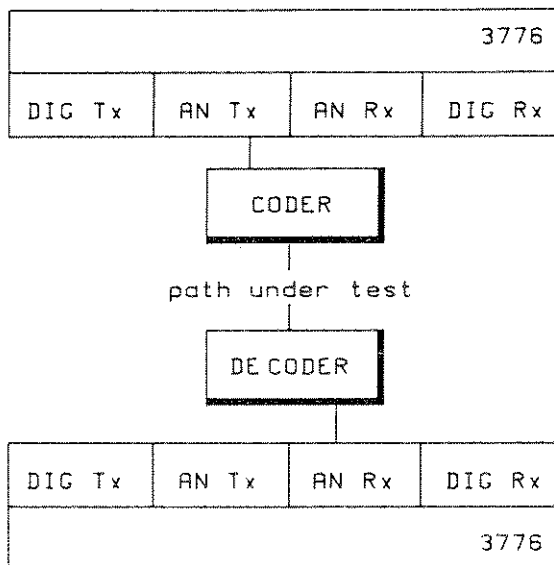

5-27 Multi Purpose End to End Testing

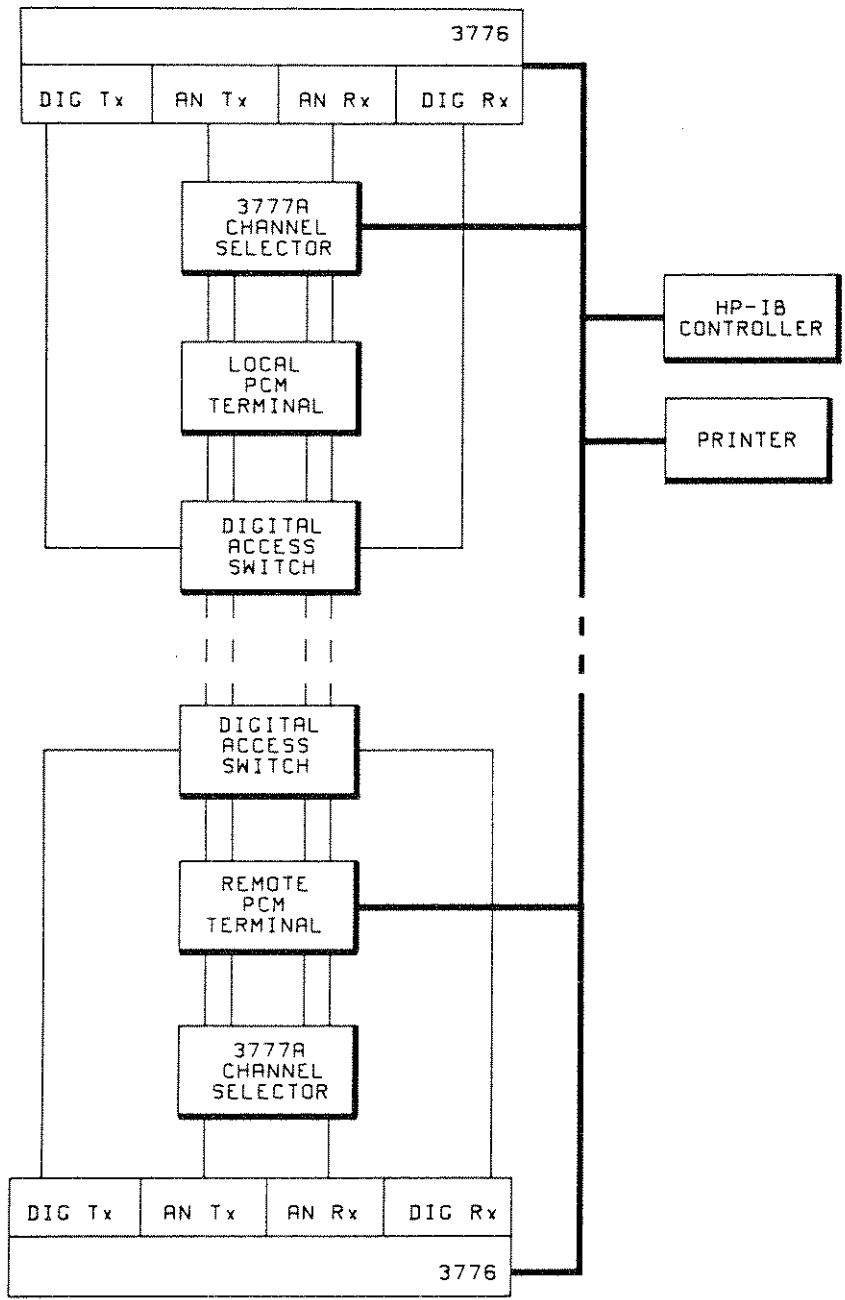



**5-28 THE AUXILIARY INPUT**

5-29 Signals applied to the rear panel auxiliary input (AUX I/P) can be routed to the analog or digital output. The digital output timeslot(s) can be selected as for operation with the internally generated signals.

5-30 Details of the use of the AUX I/P are given with LEVEL MEASUREMENTS on page 4-15

5-31 When the AUX I/P is used for communication over the line under test, it should be used in conjunction with SELF TEST 22, see page 4-15 and Appendix D.

**5-32 EXTERNAL CLOCK**

Provision is made for a 75Ω external digital clock input on the rear panel to allow, for example, synchronisation of the transmitter with an external "master" clock.

**5-33 DIGITAL DATA OUTPUT**

The rear panel DIG Rx DATA OUTPUT provides a TTL output of the received digital signal. Details are given in Appendix F.

**5-34 MONITOR OUTPUT**

the rear panel MON O/P (option 001 only) provides a monitor 600Ω balanced output of the measured signal after internal filtering. In the case of phase jitter measurements this output is the demodulated signal.

5-35 When the MONITOR OUTPUT is used for communication over the line under test, it should be used in conjunction with SELF TEST 22, see page 4-15 and Appendix D.

**5-36 OBTAINING HARD COPY OF MEASUREMENT RESULTS**

5-37 In the talk only mode, an output, suitable for a printer or plotter is provided at the rear panel HP-IB connector.

5-38 The 80 column printer output format comprises a header which includes the measurement code, operating mode and measurement parameters; and the measurement results output.

5-39 When the rear panel HP-IB ADDRESSABLE/ TALK ONLY switch is set to TALK ONLY, the required format is selected with the HP-IB ADDRESS/PRINT FORMAT switches.

5-40 The formats available are as follows:

PRINT FORMAT switch setting	Output format
0	ASCII
1	BINARY
2	80 column printer
8 to 31	plotter outputs HP GL
	A3 or A4 must = 1
	A3 and A4=1 no title or axes
	A4=1 no CCITT mask
	A2=1 auto paper advance
	A1=1 Y axis scaled
	A0=1 X axis scaled

5-41 Suitable 80 column printers are: Hewlett Packard HP 2631B, HP 2671A/G and HP 2673A. Suitable HP GL plotters are the Hewlett Packard HP 7470A, or for programmable paper advance, HP 9872C/T.

	0	1	
			PWR ON SRQ
			EOI IN SPAS
ADDR			TALK
			ONLY
A4			
A3			
A2			PRINT
A1			FORMAT
A0			
	0	1	

Setting for 80 column printer output.

	0	1	
			PWR ON SRQ
			EOI IN SPAS
ADDR			TALK
			ONLY
A4			
A3			
A2			PRINT
A1			FORMAT
A0			
	0	1	

Setting for HP GL plotter output,  
 with title and axes  
 with CCITT mask  
 without programmable paper advance  
 with fixed X and Y axes

## SECTION VI HP-IB INFORMATION

### 6- 1 INTRODUCTION

6- 2 Information on installation of HP-IB, including connecting information, rear panel ADDRESSABLE/TALK ONLY switch setting and talk only mode output selection, is given in section 2 of this manual. It should be noted that the HP-IB ADDRESS is determined by the state of the HP-IB ADDRESS switches at instrument switch on. The address cannot be changed with power applied to the instrument.

6- 3 This section provides information under the following headings:

- HP-IB CAPABILITY
- HP-IB MESSAGES
- HP-IB COMMANDS
- Types of commands
- The ? form of commands
- DATA INPUT OUTPUT FORMATS
- INSTRUMENT STATUS COMMANDS
- INSTRUMENT CONFIGURATION COMMANDS
- MEASUREMENT CONFIGURATION COMMANDS
- SEQUENCE CONSTRUCTION COMMANDS
- MEASUREMENT RUNNING COMMANDS
- DATA OUTPUT COMMANDS
- DIALLING COMMANDS
- SELF TEST COMMANDS
- THE STATUS BYTES
- NOTES ON MEASUREMENT CONTROL

### 6- 4 HP-IB Capability

IEEE488/1978			IEEE 728	
Code	Function	Capability	Code	Format/Capability
SH	source handshake	complete	PM2	program messages as fig 24/25b in IEEE 728
AH	acceptor handshake	complete	NRD1	implicit point numeric data
T5	talker	basic talker	NRD2	fixed point numeric data
		serial poll	NRD3	floating point numeric data
		talk only mode	CHDF	character data field
		untalk if MLA	BDFA	binary block data, length specified, no check
TE	extended talker	none	BDFI	binary block data, length unspecified, no check
L4	listner	basic listner	BDFH	hexadecimal data
		unlisten if MTA	,	comma parameter separator
LE	extended listner	none	;	semicolon command separator
SR	service request	complete	CRLF	CRLF command string terminator
RL	remote/local	complete	NL	NL command string terminator
PP	parallel poll	none	END	EOI command string terminator
DC	device clear	complete		
DT	device trigger	none		
C0	controller	none		

## IEEE 728 (cont)

Code	Format/Capability
MM1	measurement messages as fig 21a/21b in IEEE 728
NRD1	implicit point numeric data
NRD2	fixed point numeric data
BDFA	binary block data, length specified, no check
,	comma data separator
CRLF	CRLF data list separator
END	EOI data list terminator

**6- 5 CALIBRATION IN REMOTE (HP-IB) MODE**

6- 6 The instrument automatically self calibrates during its idle periods ie when the instrument is in the STOP state. If sufficient idle time is not available ie, with continuous operation from a controller, a 15 second wait period should be included in the program at frequent intervals for approximately 30 minutes after switch on, and then at intervals of approximately 15 minutes.

**6- 7 HP-IB MESSAGES****6- 8 Device Clear and Selective Device Clear**

6- 9 The device clear and selective device clear messages will return the instrument to its initial state. The control state is set to STOP. The HP-IB input and output buffers are cleared. The error queue is cleared. A-A GAIN (tone) is selected. PCM format and auxiliary input are set to rear panel switch settings. All other parameters retain the setting prior to the device clear.

**6- 10 Serial Poll**

6- 11 Serial poll at any time retrieves the the value of the primary status byte and clears the rsv message (SRQ) line if the 3776 requested service.

*CAUTION: The 3776 must be unaddressed after each serial poll. This occurs automatically with most HP-IB controllers.*

**6- 12 Remote Enable and Local Lockout**

6- 13 The instrument can be put into the remote state by setting the REN line and addressing the instrument to listen. It can then be returned to local either by pressing the LOCAL key or by sending the GTL message. Local lockout can be acheived by sending the REN and then the LLO messages. As the LOCAL key causes bit 3 (decimal 8) of the primary status byte to be set. The controller can be alerted to the desire to return to local control and take appropriate action.

**6- 14 HP-IB COMMANDS**

6- 15 HP-IB commands comprise a string with two or more components. The first component is always an alpha mnemonic. When it is necessary to specify parameters, the second component represents one or more parameters. This component must contain all of the necessary parameter information in the correct order, the parameters being separated with commas. The final component of a simple string, ie a single command,

or of a complex string, ie a series commands separated with semi-colons must be one of the three terminators:

- ASCII newline (identical to linefeed)
- ASCII carriage return + linefeed
- An interface EOI with the last byte of the command.

#### 6- 16 Examples of Commands

**Single command.** To set the analog transmit output to 600Ω balanced the command is: AT 600,1 Cr Lf

**Compound command.** To set the following conditions:

- operating mode AN Tx DIG Rx,
- measurement GAIN TONE,
- ANALOG TRANSMIT impedance 600Ω BAL,

the command is: M05;ME1;AT 600,1 Cr Lf

#### 6- 17 COMMAND CATEGORIES

##### 6- 18 ? Form of Commands

6- 19 Many commands have a ? form which can be used to enquire about the currently set state. The information returned is in the same form as the input using that command. The ? form can be used with all of the INSTRUMENT CONFIGURATION COMMANDS and with the MEASUREMENT SELECTION command ME?. Other uses of the ? form are given with the relevant commands.

6- 20 The 3776 responds to commands which belong to one of three categories:

- IE Immediate execution commands
- CN Configuration commands
- DO Data output commands

##### 6- 21 Immediate Execution Commands

6- 22 These are commands which do not cause data to be returned to the controller. When it is received by the 3776 it is executed and the 3776 is ready for the next command.

##### 6- 23 Configuration Commands

6- 24 There are two forms of configuration command:

- 1 A mnemonic followed by a list of parameters. These commands are similar to immediate execution commands.
- 2 A mnemonic followed by a question mark character ? These commands cause the 3776 to produce an output of the currently set parameters as a data list, identical in layout to the command format.

## 6- 25 Data Output Commands

6- 26 When a data output command is received and executed, the instrument is ready to return a data list. The controller should address the 3776 to talk and read the entire data list. The end of the data list is always marked by EOI. An instrument "hang up" as a result of failure to read the complete data list can be cleared by "device clear" or by pressing the LOCAL key twice. The output format is ASCII under the following conditions:

- No output format is specified.
- The output format parameter is 0.
- The output format parameter is omitted.

Other output format information is given with the relevant commands and in the DATA INPUT/OUTPUT FORMATS on page 6-7.

6- 27 A list of commands with the categories to which they belong is given in the following table.

FUNCTION	NUMBER OF PARAMETERS			VALIDITY			
	CATEGORY	MNEMONIC		LOCAL	REMOTE		
					STATE	STOP	RUN
Set AN Rx impedance	AR	CN	2	?	V	?	?
Add to sequence	AS	IE	0	I	V	I	I
Set AN Tx impedance	AT	CN	2	?	V	?	?
Enable/disable idle cal	CA	CN	1	I	V	I	I
Clear sequence	CS	IE	0	I	V	I	I
Set DIG Rx termination	DR	CN	1	?	V	?	?
Set DIG Tx synthesis	DT	CN	3	?	V	?	?
Report errors	ERR?	D0	0	V	V	V	V
Set PCM framing and signalling words	FS	CN	6	?	V	?	?
Device identification	ID?	D0	0	V	V	V	V
Set up idle state	IS	CN	4	I	V	I	I
Set multifrequency dialling tones	MD	CN	35	?	V	?	?
Select Measurement	ME	CN	1	?	V	?	?
Select operating mode	MO	CN	1	?	V	?	?
Set measurement parameters	MP	CN	N	?	V	?	?
Set network delay time	ND	CN	1	?	V	?	?
Output error code	OE	D0	0	V	V	V	V
Output result header	OH	D0	1	V	V	V	V
Output identifier	OI	D0	0	V	V	V	V
Output result	OR	D0	1	V*	V*	V*	V*
Output status	OS	D0	1	V	V	V	V
Output result trailer	OT	D0	1	V*	V*	V*	V*
Set PCM background idle codes	PC	CN	2	?	V	?	?
Set PCM format	PF	CN	4	?	V	?	?
Set DIG Rx timeslot	RC	CN	1	?	V	?	?
Set AN Rx TLP (dBr level)	RL	CN	1	?	V	?	?
Recall mask	RM	IE	0	I	V	I	I
Repeat current measurement point	RP	IE	0	I	I	V	V
Enable/disable SRQ response	RQS	IE	1	V	V	V	V
Recall measurement from sequence	RS	CN	1	?	V	?	?
Set signalling dialling bits	SD	CN	5	?	V	?	?
Store mask	SM	IE	0	I	V	I	I
Set SRQ response mask	SRQ	CN	1	V	V	V	V
Single step (run next measurement point)	SS	IE	0	I	V	V	V
Stop measurement	ST	IE	0	I	V	V	V
Select loudspeaker volume	SV	CN	1	?	V	V	V
Set DIG Tx timeslot	TC	CN	1	?	V	?	?
Select self test	TE	CN	1	?	V	?	?
Set AN Tx TLP (dBr level)	TL	CN	1	?	V	?	?

N=variable, V=valid, I=invalid, ?? form of command valid, V\*=valid if last result is still available.





6- 28 HP-IB INPUT/OUTPUT DATA FORMATS

6- 29 Two formats are available ASCII or binary

	ASCII	BINARY
	In the ASCII format the 3776 uses a free field input algorithm, in the following table D represents one available ASCII numeric character or sign.	In the binary format all items are sixteen bit two's complement integers; the most significant byte is sent first. The binary preamble required is "#A"
Frequency	DDDDDD Hz	A sixteen bit integer Hz
Filter	DDDD (ASCII character code of filter letter code)	A null byte followed by a single ASCII character
Level	DDDD.DD dB, dBm, dBm0...	A sixteen bit integer in mbel(0.01dB)
Code	DDDD 0 to 127 use 1 to 127 -0 to -127 use 128 to 255 or -0 to -127 if suitable for controller -128 is also acceptable for -0	A null byte followed by a single byte sign +magnitude value
NOTE: Result of IDLE STATE PCM codes (average code) measurement is TWICE coder offset.		
Ts word	DDDD decimal equivalent of the framing/signalling bit pattern	A null byte followed by a single byte containing the framing/signalling bit pattern if, < 8 bits right hand justify within 2nd byte.
Phase	DDDDD.D degrees Pk-Pk input in 5° steps	A sixteen bit integer in units of 0.1°, input in 5° steps.
Delay	DDDDDDD Seconds	A sixteen bit integer in milliseconds
Time	DDD.DDD Seconds	A sixteen bit integer in milliseconds
Duration	DDDDDD minutes	A sixteen bit integer in minutes
Count	DDDDDD	A sixteen bit positive integer
Any other	DDDD or DDDDDD	4 or 6 digit integer depending on dynamic range
NOTE: Duration used for transients, time used for network delay time and dialling.		

## 6- 30 INSTRUMENT STATUS COMMANDS

### 6- 31 Provide Status Output

```

        format
        ASCII
0S ASCII/binary
0S      0/1

```

output comprises three(4 character)fields:

```

    primary status byte  |_ see status byte information
    secondary status byte |
        control state   negative value = WAIT state
                        0 = STOP state
                        positive value = RUN state

```

cr lf

NOTE: When the data list has been read the primary status bits #2 (decimal 2) PCM and #3 (decimal 4) LOCAL are cleared. Bit #6 (decimal 32) SRQ is cleared when all of the causes of SRQ are removed, or by a Serial Poll.

### 6- 32 SRQ Disable/Enable

```

        disable/enable
RQS      0/1
RQS      OFF/ON

```

### 6- 33 SRQ Mask Selection

Use arithmetic sum of mask codes for conditions required.

```

SRQ      mask code
         1=result ready
         2=end of point
         4=digital receiver state change
         8=local key operation
        16=ready for next command
        32=error
        64/128 not selectable

```

Provide SRQ mask setting            SRQ?

```

        output comprises currently selected mask code
        in form used for SRQ mask selection above.

```

NOTE:The rear panel PON SRQ switch can be set to cause SRQ at power on.

**6- 34 Report Errors**

Two commands are available OE and ERR?

- (1) OE clears instrument error code buffer.  
resets bit 5 (decimal 32) of the  
primary status byte

output comprises:

error code 0=no errors,  
cr lf

- (2) ERR? clears instrument error code buffer.  
resets bit 5 (decimal 32) of the  
primary status byte

output comprises error code list in 4 categories:

Measurement errors. (detected during measurement execution)  
Idle errors. detected when setting up instrument idle state  
Operator errors. operation or HP-IB programming error  
P on error. Power on self Test errors

**6- 35 Provide Measurement Parameter Output**

format  
MP? ASCII

output comprises: Header MP  
Parameter list as for parameter input

**6- 36 Device Identification**

Two commands are available OI and ID?

- (1) OI  
output format ASCII  
output comprises 5 character string:3776B cr lf

- (2) ID?  
output format ASCII  
output comprises: A string with the following components  
separated with commas.  
HP3776B  
OPT 0/1 1=option 001  
OPT 0/2 2=option 002  
0 not currently used  
REV DDDD cr lf Firmware status code

## 6- 37 INSTRUMENT CONFIGURATION COMMANDS

NOTE: The ? form of each instrument configuration command can be used to enquire the current state of the relevant parameters eg, AT? will cause "AT 600 ,1 cr lf" to be returned if the analog transmitter output impedance is set to 600Ω balanced.

### 6- 38 Setting-up

#### 6- 39 Analog Transmit Impedance

```

      impedance,unbalanced/balanced
AT 600/900 ,          0/1

```

AT? causes output in above format followed by cr lf

#### 6- 40 Analog Receive Impedance

```

      impedance,terminated/bridged
AR 600/900 ,          0/1

```

AR? causes output in above format followed by cr lf

#### 6- 41 Digital Transmit Synthesis

The digital transmitter synthesis command needs only one parameter if synth PCM is selected as timeslot translation is not available in this mode.

```

      pcm ,t-slot translation
      synth/thru, disabled/enabled
DT    0
DT    0/1          0/1

```

DT? causes output in above format followed by cr lf

#### 6- 42 PCM Format

```

      format,      code      , signalling, pcm clock
      ft/fe , AMI(AZS)/B8ZS, CCS/CAS , int/ext
PF 0/1 ,          0/1      , 0/1      , 0/1

```

PF? causes output in above format followed by cr lf

#### 6- 43 PCM Framing and Signalling Bits

```

      bits
      Ft,Fe,Fs(CAS),Fs(CCS),foreground signalling (CAS),
      background signalling (CCS)
FS decimal equivalents of binary bit patterns

```

FS? causes output in above format followed by cr lf

6- 44 PCM Background Idle Codes

```

        idle code 1, idle code 2
PC  idle codes in PCM code format
    0 to 127 use 0 to 127
    -0 to -127 use 128 to 255 (preferred)
    -0 to -127 (acceptable)
    -128 is also acceptable for -0

```

PC? causes output in above format followed by cr lf

6- 45 Digital Receive Termination

```

        terminated/monitor(20dB gain)
DR          0/1

```

DR? causes output in above format followed by cr lf

6- 46 Operating Mode

```

M0  operating mode code
    0=all off
    8=DIG Tx only
    4=AN Tx only
    2=AN Rx only
    1=DIG Rx only
    9=DIG Tx - DIG Rx
    10=DIG Tx - AN Rx
    5=AN Tx - DIG Rx
    6=AN Tx - AN Rx

```

M0? causes output in above format followed by cr lf

6- 47 Analog Transmit TLP Level

TL tlp

TL? causes output in above format followed by cr lf

6- 48 Analog Receive TLP Level

RL tlp

RL? causes output in above format followed by cr lf

6- 49 Digital Transmit Timeslots

```

TC 0  all timeslots
TC +n timeslot n                (n=1 to 24)
TC -n all timeslots except timeslot n

```

TC? causes output in above format followed by cr lf

**6- 50 Digital Receive Timeslot**

RC timeslot n (n=1 to 24)

RC? causes output in above format followed by cr lf

**6- 51 Disable/Enable Idle Cal**

Idle cal is automatic calibration in STOP state

CA OFF/ON  
CA 0/1

**6- 52 Idle State (Idle state of instrument)**

6- 53 When the analog and digital transmitters are not in use (e.g. when the instrument is in the STOP state or when receive only is selected) they transmit a "background idle" signal:

AN Tx.....quiet termination  
DIG TX (SYNTH PCM).....a pair of codes, see PC command  
DIG Tx (THRU PCM).....the received PCM.

By use of the IS command this can be replaced with a foreground idle signal (holding tone) with selectable frequency and level. For the digital transmitter,the holding tone and signalling bits are transmitted in the currently selected timeslots.

6- 54 Automatic calibration in the stop state must be inhibited to permit holding tone transmission. For HP-IB operation this is achieved with the CA 0 command. If the internal "cancel auto cal" switch (A 13 switch 3) is set to off (up),the instrument will transmit the programmed holding tone instead of performing auto cal in future manual operation.

NOTE: The instrument idle state is stored in non volatile memory and is retained when the instrument is switched off. Any change will become the new default value. It should therefore be remembered that it is not possible to change the idle state from the front panel.

		AN Tx		DIG Tx	
IS		bck-gnd/f-gnd, bck-gnd/f-gnd, freq, level			
IS		0		0	
IS		0/1		0/1	freq, level

**6- 55 Network Delay Time**

ND delay in milliseconds (Rx waits before measuring)

Max value 30seconds

**6- 56 Loudspeaker Volume**

SV volume  
SV 0=off  
1=quiet  
2=loud

**6- 57 MEASUREMENT CONFIGURATION COMMANDS**

6- 58 The following information combines measurement codes with their corresponding parameter codes. The measurement code (ME measurement number) alone will call up that measurement with its default parameters. The parameter selection code (MP followed by a set of measurement parameters) will replace the parameters of the currently selected measurement.

NOTE: IM must be followed with cr lf

ME? will cause the number of the currently set measurement to be returned.

MP? will cause the currently set parameter values to be returned.

**6- 59 All Off**

ME0

**6- 60 Gain (Tone)**

ME1; MP meas freq, meas level

Result header: meas, mode, Tx timeslot, Rx timeslot

Result: meas freq, meas level, result level

**6- 61 Gain (DIG mW)**

ME2 fixed parameters 1.00kHz, 0.0dBm0

Result header: meas, mode, Tx timeslot, Rx timeslot

Result meas freq, meas level, result level

**6- 62 Digital Tx-Rx**

NOTE: Rx only modes, no parameters required

ME3; MP code 1, code 2  
codes -0 to -127, use of 128 to 255 preferred

Result header: meas, mode, Tx timeslot, Rx timeslot,  
Tx code 1\*, Tx code 2\*  
\*omitted in Rx only modes

Result result code 1, result code 2

**6- 63 Level (Selective)**

NOTE: Tx only modes, omit meas freq

Rx only modes, meas freq is the only parameter required

## Internal Signal

ME4; MP 0,Tx freq,Tx level,meas freq

## Auxiliary Input

ME4; MP 1,meas freq

Result header: meas,mode,Tx timeslot,Rx timeslot,

Aux flag\*,Tx freq\*,Tx level\*

\*omitted in Rx only mode.

Tx freq and level omitted if Aux input selected.

Result meas freq,result level

**6- 64 Level (Weighted)**

NOTE: Rx only modes, no parameters required

## Internal Signal

ME5; MP 0,Tx freq,Tx level

## Auxiliary Input

ME5; MP 1

Result header: meas,mode,Tx timeslot,Rx timeslot,

Aux flag\*,Tx freq\*,Tx level\*

\*omitted in Rx only mode.

Tx freq and level omitted if Aux input selected.

Result result level



**6- 65 Level (Other Filters)**

NOTE: Tx only mode, omit meas filter  
 Rx only mode, meas filter is the only parameter required

Internal signal

```
ME6; MP 0,Tx freq,Tx level,meas filter
                        65=3 kHz flat
                        66=DC block high pass
                        67=4.1 to 4.6kHz high pass
```

Auxiliary input

```
ME6; MP 1,meas filter

Result header: meas,mode,Tx timeslot,Rx timeslot
                Aux flag*,Tx freq*,Tx level*
                *omitted in Rx only mode.
                Tx freq and level omitted if Aux input selected.

Result      meas filter,result level
```

**6- 66 Level (Peak Codes)**

NOTE: Rx only modes, no parameters required

Internal Signal

```
ME7; MP 0,Tx freq,Tx level
```

Auxiliary input

```
ME7; MP 1

Result header: meas,mode,Tx timeslot,Rx timeslot
                Aux flag*,Tx freq*,Tx level*
                *omitted in Rx only mode.
                Tx freq and level omitted if Aux input selected.

Result      peak +ve code,peak -ve code
```

**6- 67 Idle State (Selective)**

```
ME8; MP meas freq (meas freq not applicable in
                  Tx only modes)

Result header: meas,mode,Tx timeslot,Rx timeslot

Result      meas freq,result level
```

**6- 68 Idle State (Weighted)**

ME9 no parameters with this measurement  
(MP and MP? should not be used)

Result header: meas,mode,Tx timeslot,Rx timeslot

Result result level

**6- 69 Idle State (Other Filters)**

ME10;MP meas filter (meas filter not applicable  
Tx only modes)

65=3kHz flat

66=DC block high pass

67=4.1 to 4.6kHz high pass

\*Result header: meas,mode,Tx timeslot,Rx timeslot

Result meas filter,result level

**6- 70 Idle State (Average Code)**

ME11; no parameters with this measurement  
(MP and MP? should not be used)

Result header: meas,mode,Tx timeslot,Rx timeslot

Result average code

NOTE: Result is twice coder offset. Result output is positive, -0 to -127 provided as 128 to 255

**6- 71 Gain v Level (Tone)**

ME13;MP ref freq,ref level,meas level 1,...meas level n

Result header meas,mode, Tx timeslot,Rx timeslot, ref freq,ref level

Result meas level,result level

**5- 72 Gain v Level (Sync 2kHz)**

ME14;MP ref freq,ref code,meas code 1,...meas code n

NOTE: ref freq must =2000Hz for this measurement

Result header meas,mode,Tx timeslot,Rx timeslot, ref freq,ref code

Result meas code,result level

**6- 73 Gain v Frequency**

ME15;MP ref freq,ref level,meas freq 1,...meas freq n

Result header meas,mode,Tx timeslot,Rx timeslot, ref freq,ref level

Result meas freq,result level

**6- 74 Noise with Tone**

NOTE: Rx only modes, no parameters required

ME16;MP Tx freq,Tx level

Result header meas,mode,Tx timeslot,Rx timeslot, Tx freq\*,Tx level\*  
\*omitted in Rx only modes

Result result level

**6- 75 Quantising Distortion (Tone)**

ME18;MP meas freq,meas level 1,...meas level n

Result header meas,mode,Tx timeslot,Rx timeslot

Result meas freq,measlevel,result level

**6- 76 Intermod Distortion (4 Tone)**

ME19;MP meas level

Result header meas,mode,Tx timeslot,Rx timeslot,ref level

Result 2nd order level,3rd order level

**6- 77 Intermod Distortion (2 Tone)**

ME20;MP ref freq 1,ref freq 2,ref level

Result header meas,mode,Tx timeslot,Rx timeslot, ref freq 1,ref freq  
2,ref level

Result level

**6- 78 Transients**

ME21;MP holding freq\*, holding level\*, slow/fast count, duration, gain hits threshold code: 0=2dB 1=3dB 2=4dB 3=6dB, phase hits threshold, drop outs threshold, impulse counts threshold

\*omit for Rx only mode

Result header meas,mode,Tx timeslot,Rx timeslot holding freq\*,holding level\*, slow/fast count,duration, gain hit threshold code,phase hit threshold, dropout threshold,impulse count threshold

\*omitted in Rx only mode

Result elapsed time,gain hits,phase hits,drop outs, impulse count,+4dB impulse count,+8dB impulse count

**6- 79 Return Loss**

ME22;MP meas level

Result header meas,mode,Tx timeslot,Rx timeslot,ref level

Result result level

**6- 80 Loop Timing**

ME23 no parameters required for this measurement

Result header meas,mode,Tx timeslot,Rx timeslot

Result clock phase (number 0 to 15)

**6- 81 Envelope Delay**

NOTE: In the RX only modes, envelope delay operates as a single point measurement.No parameters are required in these modes and the MP and MP? commands should not be used.

ME26;MP ref freq,ref level,meas freq 1,..meas freq n

Result header meas,mode,Tx timeslot,Rx timeslot, ref freq\*,ref level\*

\*omitted in Rx only modes

Result Tx meas freq\*,Rx ref freq,Rx meas freq,relative level, delay

\*omitted in Rx only modes

NOTE: EDD runs as a multipoint measurement without a reference point i.e. the reference point produces a result in the same way as the measurement points.

**6- 82 Remodulation**

ME27;MP Tx level

Result header meas,mode,Tx timeslot,Rx timeslot,  
Tx freq,Tx level

Result Rx ref freq,Rx meas freq,relative level

NOTE: WHERE REMOD is used a suitable NETWORK DELAY TIME should be selected.

**6- 83 Absolute Delay**

ME29;MP meas freq,meas level

Result header meas,mode,Tx timeslot,Rx timeslot

Result meas freq,meas level,delay

**6- 84 Phase Jitter**

NOTE: In the Tx only modes, omit the Rx filter parameter. In the Rx only modes, omit The Tx freq and Tx level parameters.

ME30;MP Tx freq,Tx level,Rx filter  
65=20 to 300Hz  
66= 3 to 300HzResult header meas,mode,Tx timeslot,Rx timeslot,  
Tx freq\*,Tx level\*

\*omitted in Rx only modes

Result Rx filter,result jitter

**6- 85 FT Bits (not valid with extended frame format)**ME35;MP Tx timeslot word (decimal equivalent of binary  
framing bit pattern)

Result header meas,mode,Tx timeslot,Rx timeslot

Result Rx timeslot word

**6- 86 FS Bits**ME36;MP Tx timeslot word (decimal equivalent of binary  
signalling bit pattern)

Result header meas,mode,Tx timeslot,Rx timeslot

Result Rx timeslot word

**6- 87 FE Bits (only valid with extended frame format PF, 1, .)**

ME37;MP Tx timeslot word (decimal equivalent of binary framing bit pattern)

Result header meas,mode,Tx timeslot,Rx timeslot

Result Rx timeslot word

**6- 88 Timeslot Signalling Bits (only valid with CAS format PF, ., ., 1, .)**

ME38;MP Tx timeslot word

Result header meas,mode,Tx timeslot,Rx timeslot

Result Rx timeslot word

**6- 89 CRC Bits (digital receive extended frame format only)**

ME39 no parameters required  
MP and MP? commands should not be used

Result header meas,mode,Tx timeslot,Rx timeslot

Result CRC bits

**6- 90 Dialling**

ME40; for details see dialling section

**6- 91 THE STORE AND RECALL FUNCTIONS****6- 92 Store Measurement Mask**

SM equivalent to front panel STORE key

**6- 93 Recall Measurement Mask**

RM equivalent to front panel RECALL key

**6- 94 MEASUREMENT RUNNING COMMANDS**

6- 95 Measurements are performed via HP-IB using the S/STEP command. The wait state is automatically entered on completion of each step.

**6- 96 Single Step**

SS (only valid in the stop or wait states)

**6- 97 Repeat**

RP (only valid in the wait state )

**6-98 Stop**

ST (aborts current measurement)

**6-99 DATA OUTPUT COMMANDS**

6-100 The formats available with data outputs in this section are as follows:

none=ASCII 0=ASCII 1=BINARY 2=80 column printer 8 to 31=HP-GL plotter, see Appendix C for details.

**6-101 Output Result Header**

OH,format

**6-102 Output Result**

OR,format

**6-103 Output Result Trailer**

OT,format

**6-104 Output Error**

OE,output in decimal cr lf

**6-105 Output Identification**

OI,output 5 characters string cr lf

**6-106 MEASUREMENT SEQUENCE CONSTRUCTION COMMANDS****6-107 Clear Measurement Sequence**

CS

**6-108 Add Measurement to Sequence**

AS

**6-109 Recall from Sequence**

RS,seq point (number of the measurement point in the sequence, first point =1)

**6-110 Enquire, Number of Measurements in Sequence**

RS? multi-point measurements count 1.

5-111 DIALLING COMMANDS

6-112 SET MULTIFREQUENCY DIALLING TONES

MD on time,off time,level,tone pair1,...tone pair 16

on time and off time in Seconds,resolution .001s  
tone pairs in Hz.

tone pairs	digit(s) dialled
1 to 9	1 to 9
10	0
11	*
12	#
13	A
14	B
15	C
16	D

6-113 FACTORY PRESET DEFAULT VALUES

6-114 The instrument is shipped from the factory with the following tone pairs programmed:

digits	tone pair Hz
1	697 1209
2	697 1336
3	697 1477
4	770 1209
5	770 1336
6	770 1477
7	852 1209
8	852 1336
9	852 1477
0	941 1336
11	941 1209
12	941 1477
13	697 1633
14	770 1633
15	852 1633
16	941 1633



## 6-115 SET SIGNALLING BIT DIALLING PARAMETERS

SD on-hook code,off-hook code,mark time,space time,interdig time

on-hook code |  
 | - decimal equivalent of binary signalling  
 off-hook code | bit pattern

mark time,space time,interdigit time integers in seconds

## Factory Preset Default Parameters

on-hook code	0
off-hook code	15
mark time	0.000
space time	0.120
interdig time	0.500

## 6-116 Dial Line Required

## 6-117 DIAL VIA SIGNALLING (DIG Tx ONLY)

ME40;MP 1,number required (n digits [MAX 40]  
 separated by commas);SS

## 6-118 MULTIFREQUENCY DIALLING (AN Tx OR DIG Tx)

NOTE: Before using analog signalling the internal calibration of the instrument should be switched off (CA 0 or CA OFF)

ME40;MP 2,number required (n digits [MAX 40]  
 separated by commas);SS

code for digits of number dialled as for tone pairs above.

## 6-119 CONTINUOUS PULSE SIGNALLING (DIG Tx ONLY)

ME40;MP 0

6-120 SELF TEST COMMANDS

Perform self test           TE test number  
 Enquire, currently set    TE?  
 test number

test number	test function
0	exit self test mode, return to previous meas set-up
1	full self calibration (tests 2 to 11)
2	A Tx gain
3	A Rx gain
4	A RX autorange paths gain
5	calibrate A Rx autorange
6	A Tx attenuator paths Gain
7	calibrate A Tx attenuator
8	A Tx flatness (16kHz path)
9	A Rx flatness
10	A Tx flatness (8kHz path)
11	transients circuit gain
12	A Rx flatness / CCITT weighting mask
13	processor ROM (CRCs)
14	non volatile RAM
15	plot results RAM
16	internal instrument bus
17	front panel display test
18	analog Tx-Rx via internal test link
19	digital Tx-Rx via internal test link
20	digital filter confidence Test
21	PCM functions test
22	conversation mode

6-121 THE STATUS BYTES

1 primary status byte

decimal equivalent of status byte	
1	result ready
2	end of measurement point
4	change of state of the digital receiver signal/alignment
8	LOCAL key has been pressed
16	instrument ready for next command (always 0 with OS)
32	an error code has been produced
64	service requested
128	instrument has just powered up (cleared by device clear or instrument configuration change)

2 secondary status byte

decimal equivalent of status byte	
1	digital Rx multiframe alignment loss
2	digital Rx frame alignment loss
4	digital Rx detected all 1s
8	no PCM signal for digital Rx
16	not assigned
32	option 001 fitted to instrument
64	option 002 fitted to instrument
128	instrument identification 3776B

**6-121 NOTES ON MEASUREMENT CONTROL**

6-122 Running 3776 measurements remotely is slightly different to local control using the front panel control keys. The "ST", "SS" and "RP" commands correspond to the STOP, STEP and REPEAT front panel keys, but there are no remote equivalents of RUN and WAIT. Note also that the "RP" command is only valid in the wait state and the "SS" command is only valid in the stop or wait states.

6-123 Two bits in the primary status register are of importance in the correct control of 3776 measurements. These are bit #0 (Result Ready) and bit #1 (End-of-Point).

6-124 The 'Result Ready' bit is set whenever the 3776 has a new result available. The "OR" command can be used to recover this result as long as this bit remains set. The bit is cleared by the "OR" command, when a "SS" or "RP" command causes the instrument to re-enter the run state, or when the instrument configuration is altered. Note that when the instrument is in a transmit only operating mode results are never generated and the 'Result Ready' will always be clear.

6-125 The 'End-of-Point' bit is set when the instrument enters the wait state at the end of a measurement point, or the stop state at the end of a measurement. It is cleared by a "SS" or "RP" control command.

6-126 Care should be taken when designing the section of controller program that waits for changes in the above bits. The preferred method is to enable the 3776 to SRQ on the appropriate status change. A SRQ interrupt routine is then required in the controller to handle these interrupts. This may be over-complex for some operations. As an alternative the controller can implement these waits by continually reading the 3776 status until the required event happens. If this latter method is chosen, serial poll should be used to read the status. Continual execution of the "OS" command puts a high overhead on 3776 processor which will cause any measurement to progress very slowly. In very fast controllers (such as the HP9826 series) even a looped serial poll may slow down measurements significantly. If this happens insert a small delay (say 10ms) in the wait loop before each serial poll.

6-127 Be careful when using serial poll immediately following a programming command that may change a primary status (e.g. the "SS" command). Here always make sure that the READY bit (bit #4) is set before acting on value of any other status bits. This ensures that the execution of the preceding command has been completed.

6-128 As far as the measurement control is concerned, there are five

- Single Point
- Multipoint
- Multipoint + Reference
- Framing/Signalling
- Special

6-129 In Tx + Rx operating mode the first three types are controlled in a similar manner. Single point measurements are just multipoint ones with only one point. Multipoint + Reference type measurements run a reference point before the first measurement point, but this is transparent to the controller. A typical sequence for one measurement point is performed as follows:

```

CONTROLLER                                3776

UNL                                        #
controller talk                           #
3776 listen                                #
"SS" ----->                             #
#                                           run (next) point
wait for RESULT                            #
# <----- generate result
UNL                                        #
controller talk                           #
3776 listen                                #
"OR" ----->                             #
# <----- output result
read result                                #
wait for EOP                              #
# <----- enter wait state

```

6-130 This sequence is repeated for each measurement point in the mask. The "SS" command will return the 3776 to the stop state when there are no more points to be run. Replacing the "SS" command by a "RP" command in the above sequence will run the current point again, instead of the next point.

6-131 Tx only and Rx only operating mode control is more complicated. These modes will generally only be utilised when two 3776s are used, one at each end of the circuit under test. One instrument would be in the Tx only mode and the other in the Rx only mode. A typical control sequence is performed as follows:

```

CONTROLLER                                Tx 3776                                Rx 3776

UNL
controller talk
Tx 3776 listen
"SS" ----->                                #
#                                           run (next) point
wait for EOP                                #
# <----- enter wait state
UNL                                        #
controller talk                             #
Rx 3776 listen                              #
"SS" ----->                                #
#                                           run (next) point
wait for result                             #
# <----- generate result
UNL                                        #
controller talk                             #
Rx 3776 listen                              #
"OR" ----->                                #
# <----- output result
read result                                #
wait for EOP                                #
# <----- enter wait state
#                                           #

```

6-132 With the Multipoint + Reference type of measurement there is an added complication in Tx only and Rx only modes. Here the reference point is not transparent to the controller. It appears as an additional point prior to the first measurement point, except that no result is generated. In the following typical sequence it is assumed that both instruments are initially in the stop state.

CONTROLLER	Tx 3776	Rx 3776
UNL		
controller talk		
Tx 3776 listen		
"SS" ----->	#	
#	run ref point	
wait for EOP	#	
# <-----	enter wait state	
UNL	#	
controller talk	#	
Rx 3776 listen	#	
"SS" ----->		#
#		run ref point
wait for EOP		#
# <-----		enter wait state
UNL		#
controller talk		
Tx 3776 listen		
"SS" ----->	#	
#	run first point	
wait for EOP	#	
# <-----	enter wait state	
UNL		
controller talk		
Rx 3776 listen		
"SS" ----->		#
#		run first point
wait for result		#
# <-----		generate result
UNL		#
controller talk		#
Rx 3776 listen		#
"OR" ----->		#
#		output result
read result		#
wait for EOP		#
# <-----		enter wait state
#		#

**6-133 Miscellaneous Notes**

6-134 The Framing/Signalling measurements are only applicable in DIG Tx only and DIG Rx only modes. These measurements never enter the wait state. In the DIG Rx mode they produce a result whenever a relevant bit changes state.

6-135 The EDD measurement runs as a multipoint measurement WITHOUT a reference point. i.e. the reference point generates a result in the same way as the measurement points. When running EDD with remote remodulation in the signal path, the controller should set up a suitable network delay time (see the "ND" command) to allow for remodulation settling. Further details of this measurement can be obtained in "Getting The Most Out Of Your Group Delay and Envelope Delay Measurements" HP Publication 5953-5461.

6-136 The Transients measurements are a special single point measurement, they never enter the wait state. A result is produced each time an event occurs in a one minute window (although the controller does not have to read every result). The "OR" command can be used at any time during this measurement and the 3776 will return the latest event counts.

6-137 The Phase Jitter and Loop Timing measurements run in a continuous repeat mode and never enter the wait state. A continuous stream of results is produced which the controller has the option of reading. (Note The Phase Jitter measurement filter takes time to settle and the result should only be read after the appropriate settling time.)





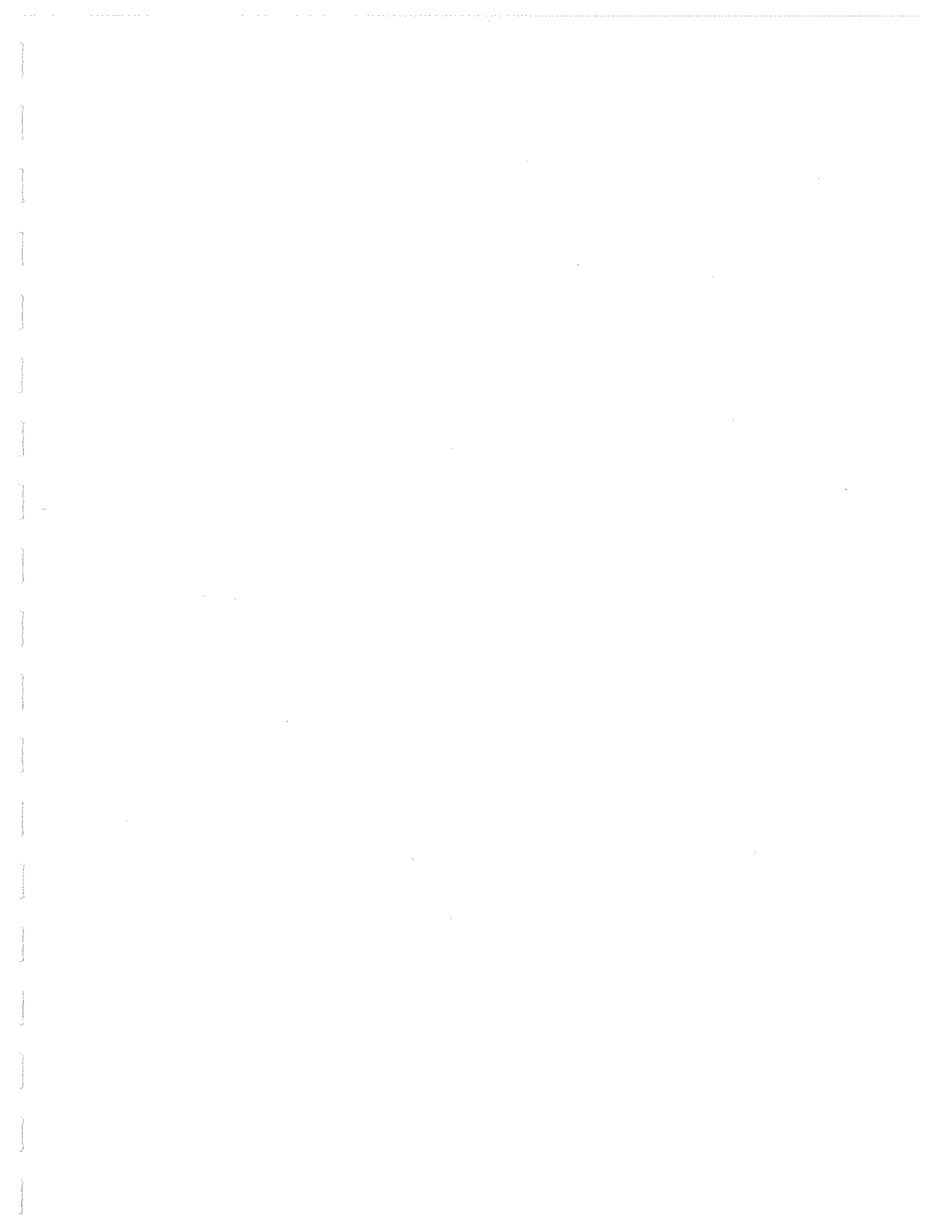



**SECTION VII  
MANUAL UPDATES**

**7-1 UPDATE INFORMATION**

Instruments with serial numbers of 2404U-00242 and above make change 1.

**7-2 CHANGE 1**

Add the following information:

Page 6-22:

The code for dialling digit 0 can be 0 or 10.

Page 6-23

**SINGLE FREQUENCY DIALLING (AN Tx or DIG Tx)**

**NOTE:** Before using single frequency dialling the internal calibration of the instrument should be switched off (CA 0 or CA OFF).

ME40;MP 3,number required (n digits [MAX 40] separated by commas);SS digit 16 is a null digit i.e. a space.

The frequency and level are selected from the multi-frequency dialling (MD) parameter list, the frequency being the first frequency of the first tone pair (default value 697Hz). The on time, off time and interdigit time are selected from the dial via signalling (SD) parameter list, The tone being transmitted during the "on time". All times are nominal.







**APPENDIX A**

Definitions of dBm, dBm0, TLP, dBr and their uses in the 3776.

**A1** In order to understand Tx TLP and Rx TLP values, it is helpful to know about the units (dBr, dBm and dBm0) used in a transmission system, and their relationship.

**A2 Definition of dBm**

**A2-1** dBm are logarithmic units of absolute power referred to 1mW. 0dBm = 1mW

**A3** The absolute power of a signal can be measured at any point in a transmission system, but it is only meaningful when related to the power which should occur at that point. This is achieved by defining a notional system reference point in the transmission system (the OTLP or 0dBr point) and describing the power of a signal at any point in the system in terms of the power which the same signal would have at the system reference point.

**A4 Definition of dBm0**

**A4-1** If a signal is applied to the system such that the power at the system reference point is xdBm, then the nominal power is said to be xdBm0 at all points in the transmission system.

dBm0 are units describing the relative power of a signal independent of the point at which it is measured.

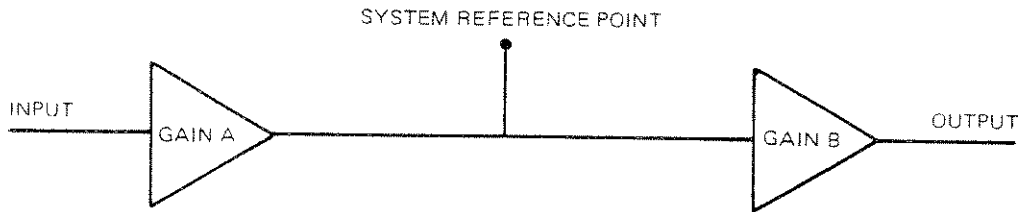

TRANSMISSION SYSTEM (as used in the following text)

**A5** Standard test signals are arranged to have a level of 0dBm at the system reference point, a condition known as the nominal loading level.

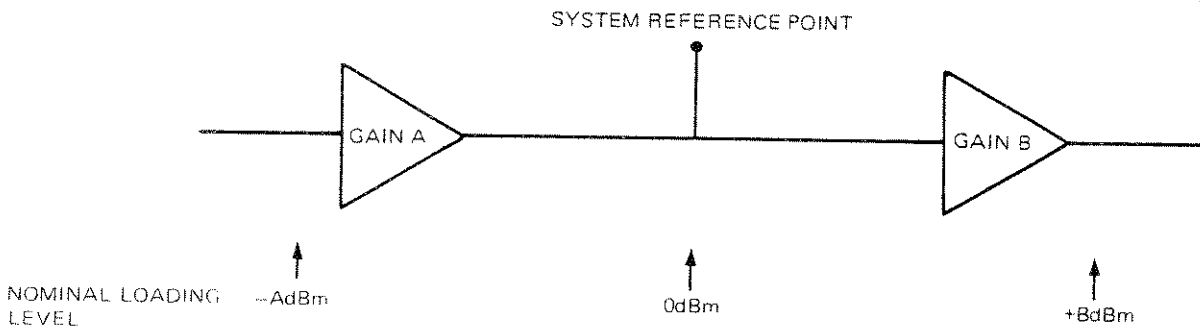

**A6** The relative power in dBm0 gives the relationship between the absolute power and the nominal loading level irrespective of the point in the system at which it is measured. dBm0 are therefore useful when making measurements over the whole length of a transmission system.

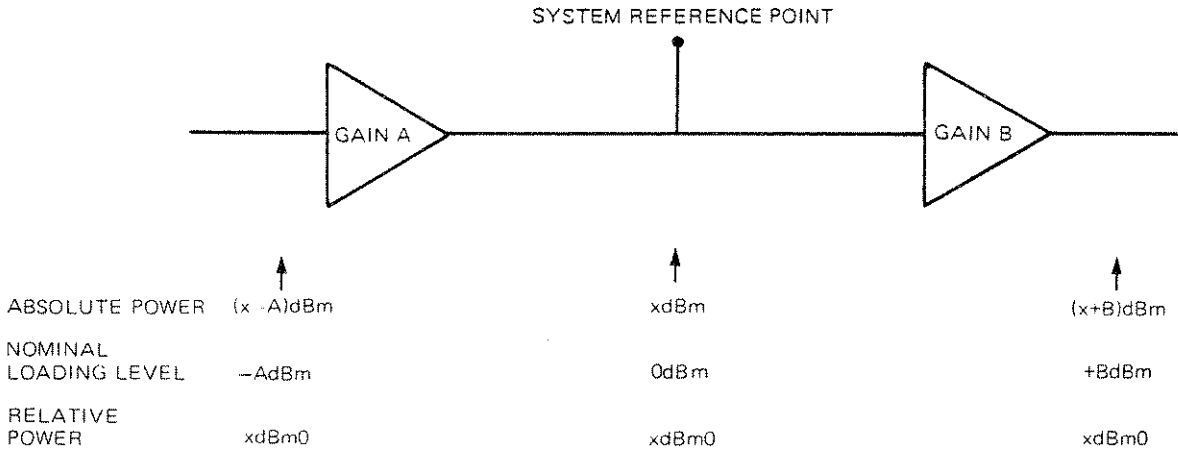

**A7 Definition of dBr**

**A7-1** The power expected at a point in a transmission system compared with that expected at the system reference point is described as the relative level of the point and has the units dBr. Physically, the relative level of a point describes the gain or attenuation between that point and the reference, and it has the same numerical value in dBr as the nominal loading level expressed in dBm.

**A7-2** If a signal is applied to a system such that the power at the system reference point is 0dBm, then the relative level of a point where the power is xdBm is said to be xdB. dBr are units describing the relative level at a point independent of the absolute power there.

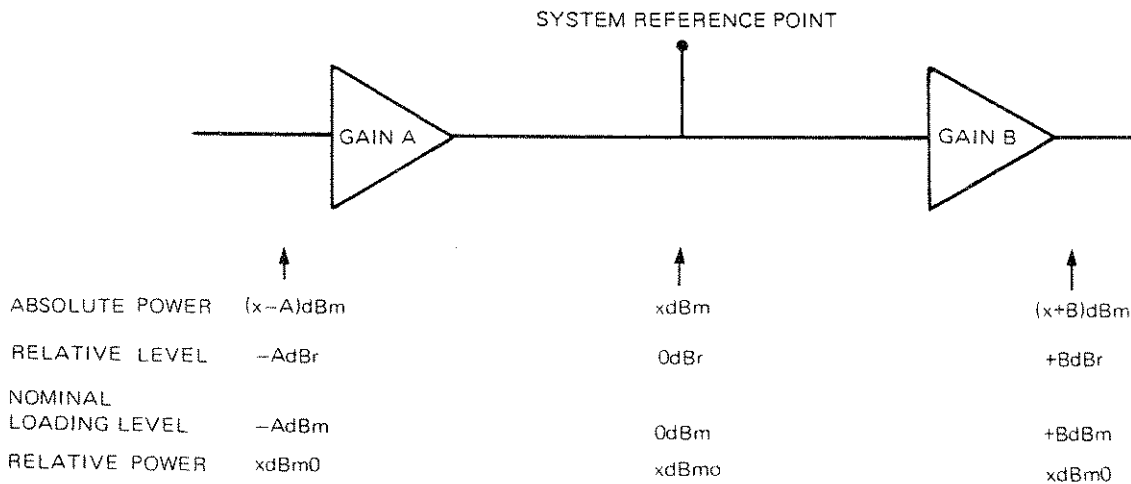



**A8** An example of a typical transmission system operating at a level of  $-10\text{dBm}_0$  is shown below.

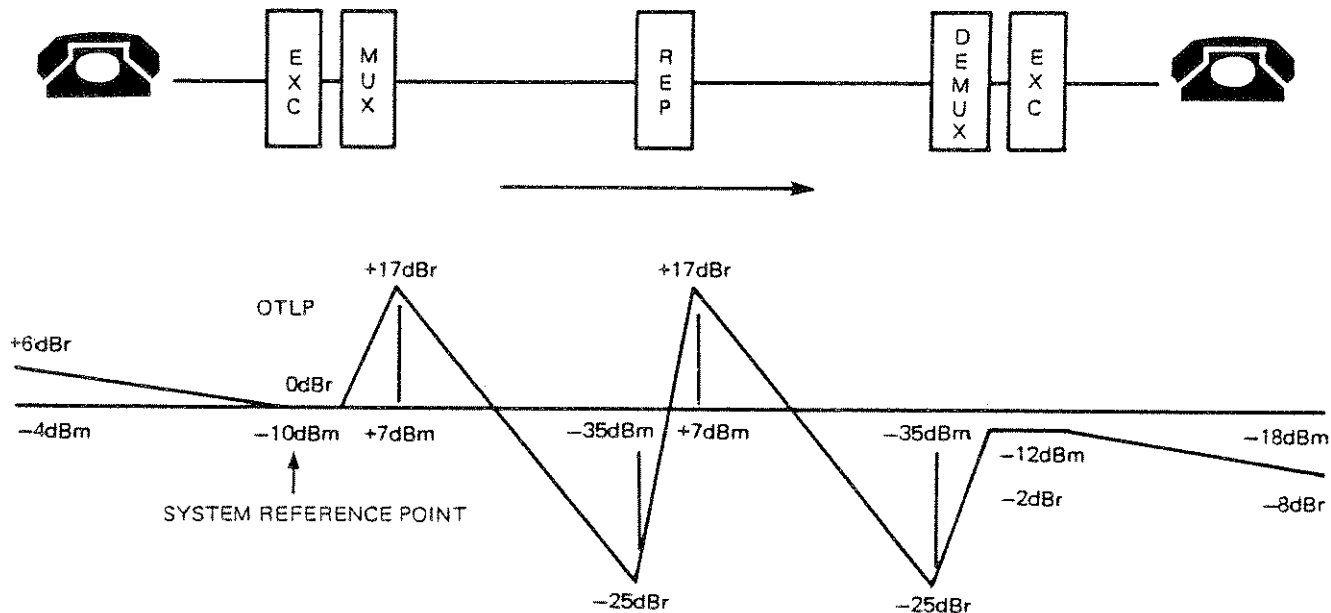

*NOTE: The relative power level (dBm-dBr) is  $-10\text{dBm}_0$  at all points.  
At the system reference point  $\text{dBm}_0 = \text{dBm}$ .*

**A9** In the 3776, LEVEL parameters are entered in units of  $\text{dBm}_0$ . A value in  $\text{dBm}_0$  alone does not define the absolute power appropriate for the system under test: in order to calculate the correct absolute power for the system input (i.e. at the 3776 output), the instrument must also know the relative level (dBr) at the system input i.e. Tx TLP.

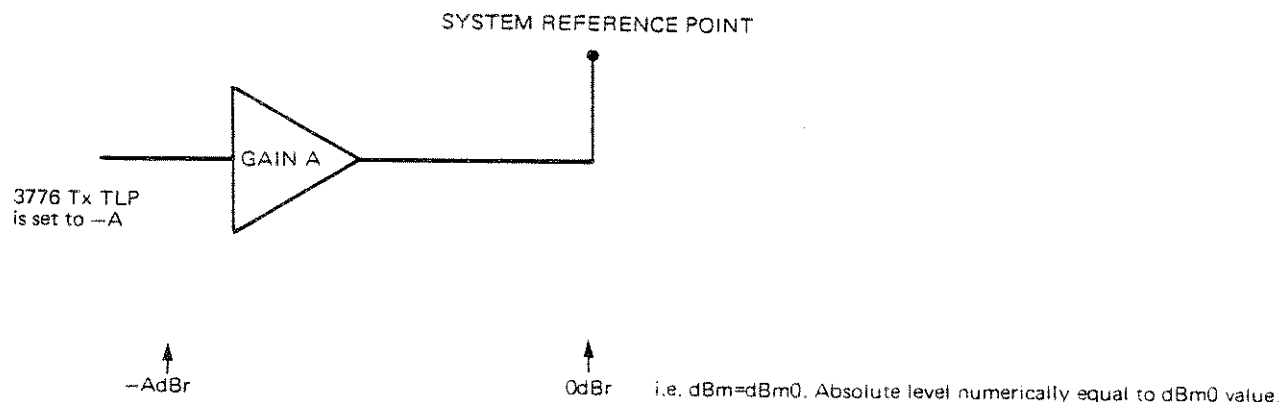

**A10** The Tx TLP can be thought of as the negative of the gain between the input point and the system reference point. The absolute input power to the system under test is (dBm0 + Tx TLP). Similarly, in order to interpret the absolute power measured at the output of the system under test in terms of power expected there, the 3776 uses the value of Rx TLP.

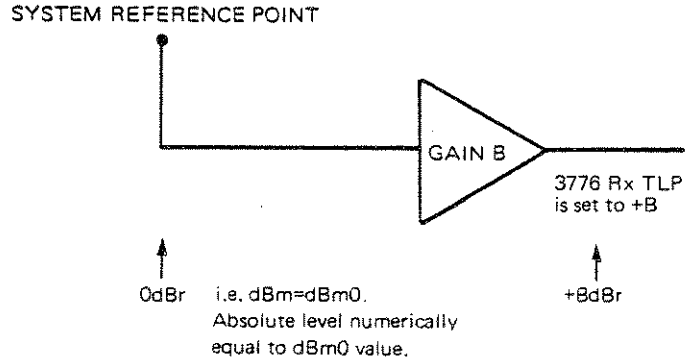

**A11** The Rx TLP can be thought of as the gain between the system reference point and the output point. The expected absolute power out is (dBm0 + Rx TLP).

**A12** For any transmission path, Rx TLP - Tx TLP is the expected gain. The result displayed by a GAIN measurement on a 3776 is the difference between the measured absolute gain and the expected gain (Rx TLP - Tx TLP).

**NOTE:** If the 3776 Tx output and Rx input are connected together, the displayed GAIN result will be - (Rx TLP - Tx TLP). This is because Tx TLP and Rx TLP compensate for the normal gain of the system.

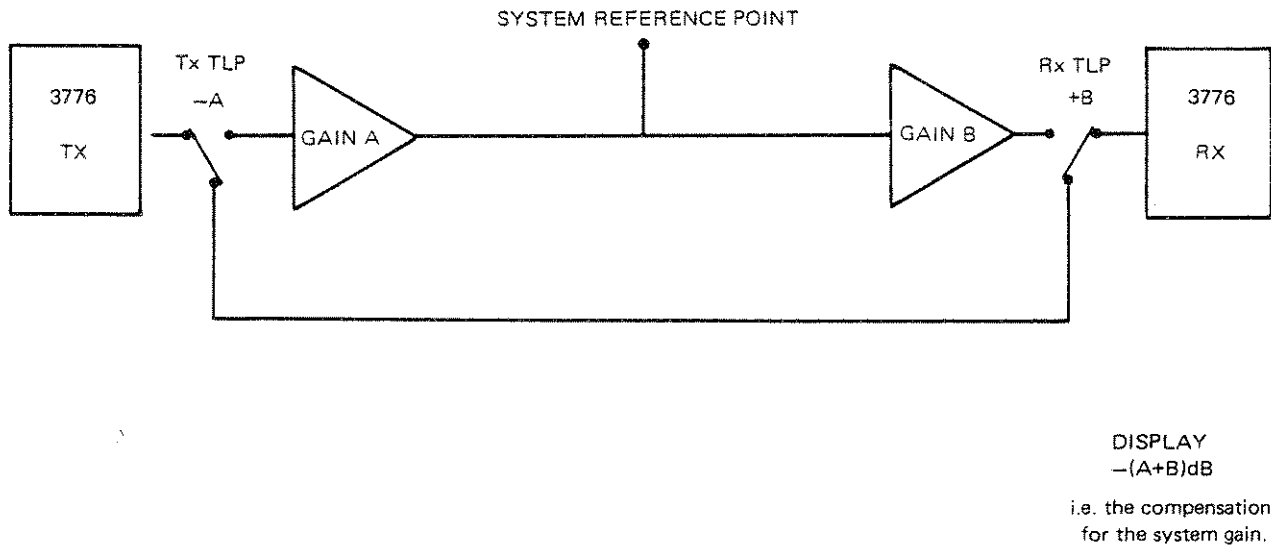

**A13**      **Definitions of Other Units**

- dBmOp**      Signal or noise level with psophometric weighting measured in dBmO. (Using CCITT telephone weighting filter in recommendation P. 53.)
- dBmO**      Signal or noise level relative to the level that a tone 90dB down on the standard test tone would have at the same point in the system.
- dBmCO**      Signal or noise level with C-Message weighting measured in dBmO.



## APPENDIX B Frame Structures

**B1**

**North American 1544 kbit/s PCM Frame Structure (CAS)  
(BSTR Pub 43801 [CCITT Rec G. 733] )**

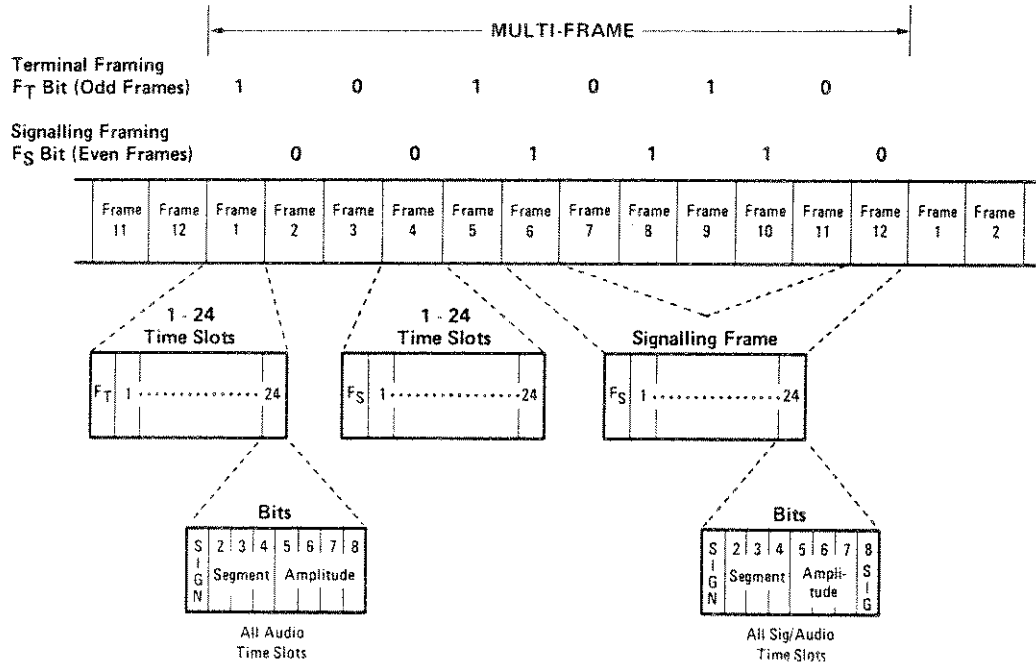

**B2** Extended Superframe (ESF) structure. The Extended Superframe (ESF) structure is denoted as FE on the 3776B.

**North American Extended Framing Format (F<sub>E</sub>)**

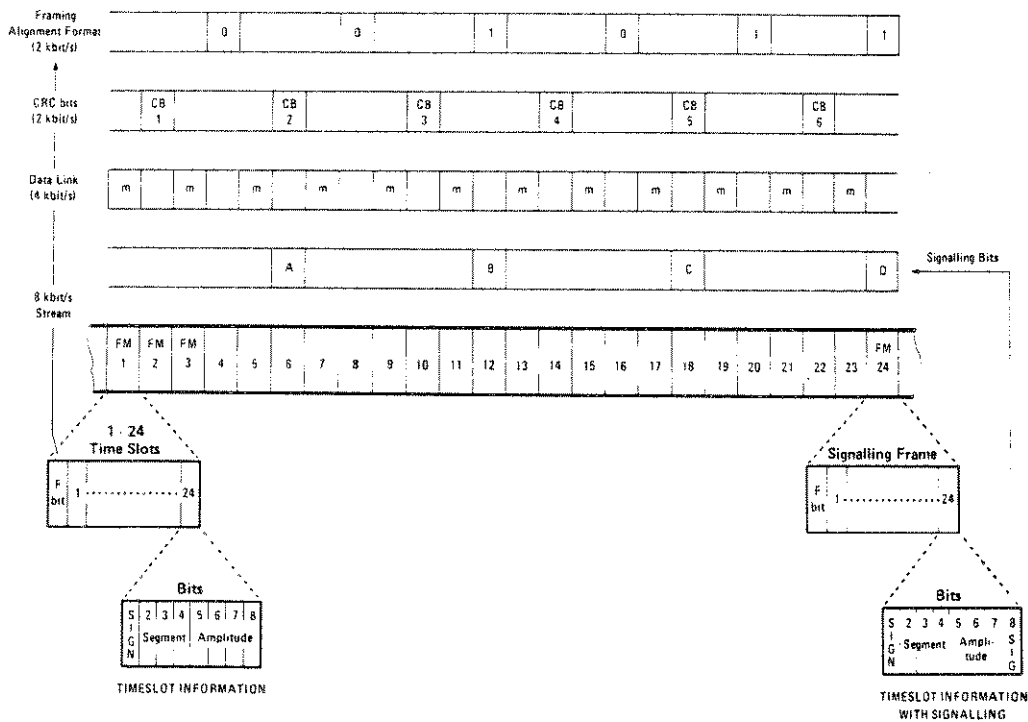

The extended framing format (FE) 'extends' the DS1 structure from 12 to 24 frames, giving a total of 4632 bits. Each frame contains 1 bit for framing control, followed by 192 (24x8) information bits. These framing/control bits, operating at 8 kbit/s are divided into three separate patterns.

- a) Framing bits; located in the 1 st. bit in frames: 4, 8, 12, 16, 20, and 24. The pattern is 001011.
- b) CRC-6 error checking bits; located in the 1 st. bit in frames: 2, 6, 10, 14, 18, and 22. These are designated CB1-CB6 respectively and are generated using a 6 th. order polynomial.
- c) A 4kbit/s general purpose data link; distributed throughout the 1 st. bits of the remaining frames, designated 'm'.

Signalling is similar to that of the DS1 frame structure. In addition to having 'robbed' bits in the 6 th and 12 th frames, there are also 'robbed' bits in the 18 th and 24 th frames. The four signalling bits per channel are designated A, B, C and D.

**APPENDIX C**

Plot Options

**C1** The following table gives the rear panel switch setting (Format Number) for the various plotter output formats available.

Format Number	Plot Title and Axes	Plot CCITT Mask	Auto Paper Eject	Scale Y Axis	Scale X Axis
8	•	•			
9	•	•			•
10	•	•		•	
11	•	•		•	•
12	•	•	•		
13	•	•	•		•
14	•	•	•	•	
15	•	•	•	•	•
16	•				•
17	•				•
18	•			•	
19	•			•	•
20	•		•		
21	•		•		•
22	•		•	•	
23	•		•	•	•
24					•
25					•
26				•	
27				•	•
28			•		
29			•		•
30			•	•	
31			•	•	•





## APPENDIX D SELF TEST AND CALIBRATION

### D1 Automatic Calibration

D1-1 The 3776 performs a number of self calibration and self test procedures. When the instrument is switched on it automatically performs a calibration cycle. If an attempt is made to run a measurement before the calibration cycle is complete the start of the measurement will be delayed. Any faults which prevent generation of the calibration correction figures are indicated at this stage. Note that when a measurement run is performed only the appropriate calibration figures are used. Recalibration occurs automatically when the instrument is in the STOP state.

### D2 Self Test

D2-1 The self test program contains 22 points or "tests". These "tests" include calibration, tests, and the facility to select communication over the system under test, "conversation mode". When the SELF TEST key is pressed, the display shows point 1. points 1 to 22 can be displayed by using the NEXT PARAM and PREVIOUS PARAM keys. Select the required point (listed in the table below) and press RUN to perform that "test".

D2-2 Note that test 1 "CAL" generates all of the internally needed calibration values which are generated individually in tests 2 to 11. In test 1 no attempt is made to use the values generated, it therefore indicates only major failures. Out of range calibration figures will be indicated when an attempt is made to use them, either during a measurement or when the individual test points 2 to 11 are performed.

D2-3 Note that "test" 22, conversation mode, is accessed in the same way as other tests. this mode provides connection between the rear panel AUX I/P, the MON O/P and the system under test without autoranging.

D2-4 The following table provides a list of tests with their corresponding numbers:

Test Number	Test Function
1	full self calibration (tests 2 to 11)
2	AN Tx gain
3	AN Rx gain
4	AN Rx autorange paths gain
5	calibrate AN Rx autorange
6	An Tx attenuator paths Gain
7	calibrate AN Tx attenuator
8	AN Tx flatness (16kHz path)
9	AN Rx flatness
10	AN Tx flatness (8kHz path)
11	transients circuit gain
12	AN Rx flatness/CCITT weighting mask
13	processor ROM (CRCs)
14	non volatile RAM
15	plot results RAM
16	internal instrument bus
17	front panel display test
18	analog Tx-Rx via internal test link (see Appendix E)
19	digital Tx-Rx via internal test link
20	digital filter confidence Test
21	PCM functions test
22	conversation mode

**APPENDIX E**  
**OPERATIONAL TROUBLESHOOTING 3776B**

E1 The following information details some of the conditions which can give rise to operational difficulties.

PROBLEM	POSSIBLE CAUSE/CURE
ANALOG GAIN/LEVEL measurement producing consistantly incorrect results	TLP not set, default value is automatically set to value at last switch off.
CLOCK ERRORS, ALL MODES	Rear panel DIG Rx CLOCK I/P set to EXT with no external input.
END TO END MEASUREMENT producing incorrect results	Reference level/frequency of receiving instrument must be set to reference of transmitting instrument.
FRAMING/SIGNALLING or BACKGROUND PCM preventing correct operation	Previously selected data stored and is now new default condition. Receiver expects frame word: 1010101. Multiframe alignment work or sig framing word: 001110.
IDLESTATE (WEIGHTED) digital operation. Wrong background PCM output.	For DIG TX only or DIG Tx DIG RX, transmitted background PCM is +0,-0. For DIG RX only, transmitted background PCM is stored DIG Tx/Rx codes.
I/MOD DISTORTION 4 TONE DIFFICULTY IN OBTAINING SECOND RESULT DISPLAY	Second result is displayed with NEXT PARAM key.
INSTRUMENT "HANGS UP" AS A RESULT OF NOT READING COMPLETE DATA LIST OVER HP-IB	Send DEVICE CLEAR or press LOCAL key twice.
KEYS INOPERATIVE	Instrument not in STOP state or in REMOTE mode.
MEASUREMENT SELECTION INHIBITED	Measurement not valid in currently selected operating mode e.g. selection of GAIN (Digital mW) with AN Tx OPERATING MODE selected. See also KEYS INOPERATIVE.
SELF TEST 18 FAILS	Analog receiver should not be set to BRIDGED.
TIMESLOT TRANSLATION INOPERATIVE	Timeslot translation requires THRU PCM selection.



## APPENDIX F THE DIG Rx DATA OUTPUT

### F1 INTRODUCTION

F1-1 The rear panel digital receive data output provides a TTL low true open collector output which can be used for further processing by other instruments or systems.

The outputs provided are:

OUTPUT	PIN NO
PCM BIT PATTERN	8
RECEIVER CLOCK	14
DATA VALID	1
FRAME SYNC	4
MULTIFRAME SYNC	5
CONTROL SIGNAL	10

The following information provides further details of these outputs.

**F2 PCM BIT PATTERN**

(serial,NRZ data,most significant bit first,sign bit inverted)

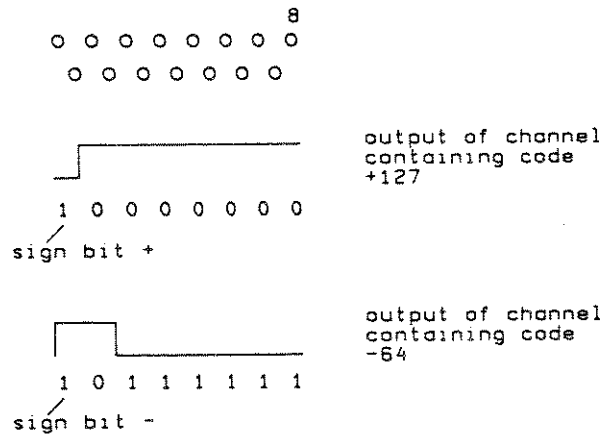

**F3 RECEIVER CLOCK**

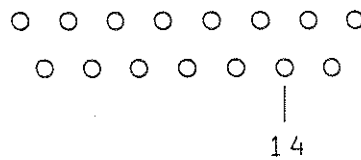

F3-1 The receiver clock signal is always present when the instrument is switched on.

The following figure shows the relationship between the receiver clock signal,the PCM bit pattern (pin 8) and data valid (pin1)

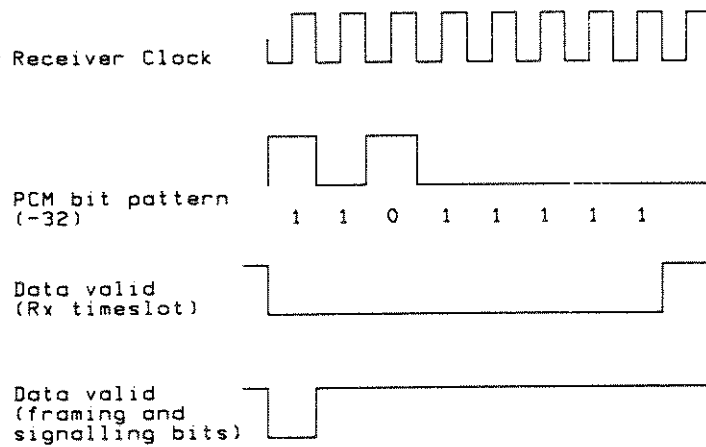

**F4 DATA VALID**

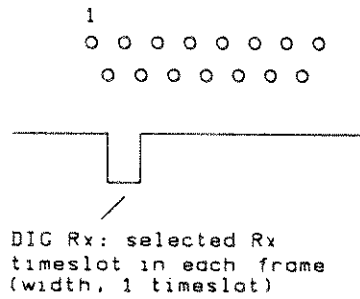

DIG Rx: selected Rx timeslot in each frame (width, 1 timeslot).

F4-1 DIG Rx FRAMING and SIGNALLING:  
 (width, one clock period)

**NORMAL FRAME**  
 location of : Ft bits, F's bits and signalling bits  
**EXTENDED FRAME**  
 location of: Fe bits, CRC bits and signalling bits

The following figure shows the DATA VALID signals for the Rx framing and signalling, relative to the frame sync (pin 4) and the multiframe sync (pin 5).

The relationship between data valid, PCM data and receiver clock signals is given in the RECEIVER CLOCK information.

**F4-2 Normal Frame**

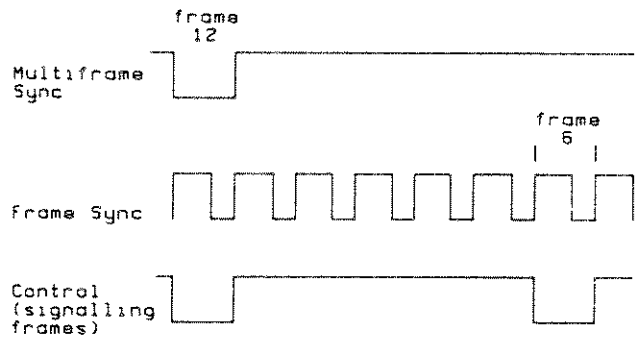

F4-3 Extended Frame

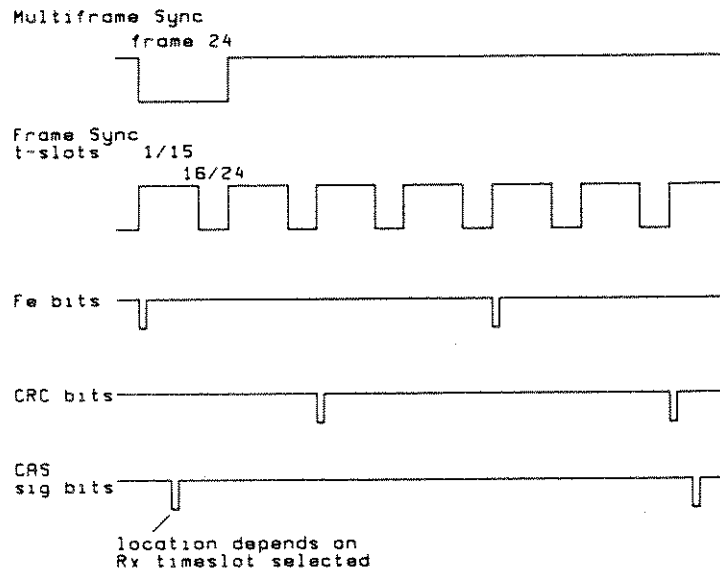

Further details of framing structures are given in appendix B.



F5 FRAME SYNC

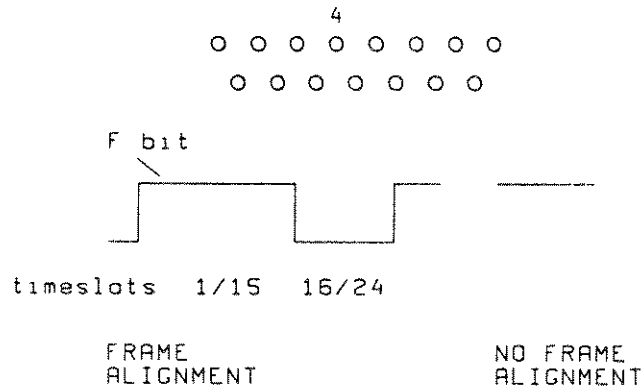

F6 MULTI FRAME SYNC

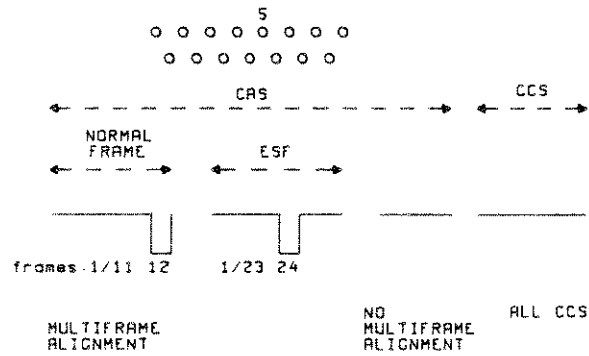

F7 CONTROL SIGNAL (CAS SIGNALLING FRAMES INDICATOR)

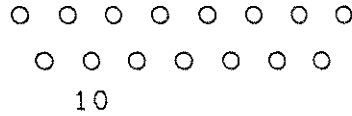

The following figures show the control signal relative to the multiframe sync (pin 5) and the frame sync (pin 4)

F7-1 Normal Frame

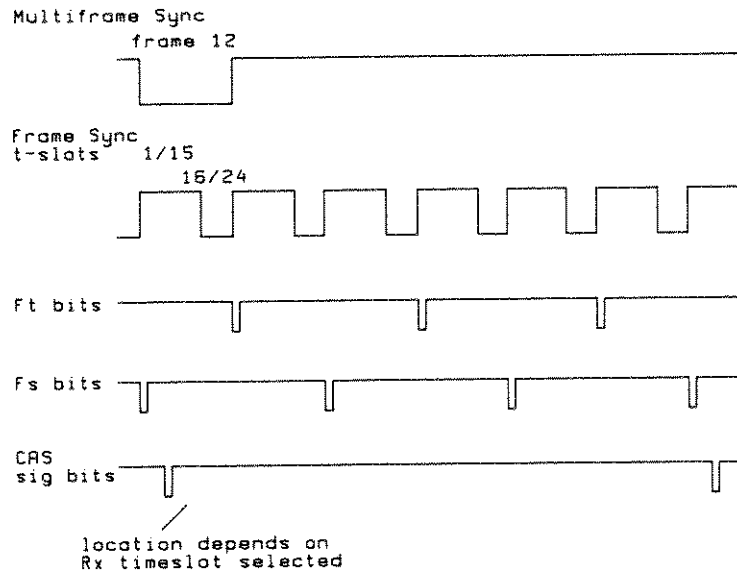

F7-2 Extended Frame

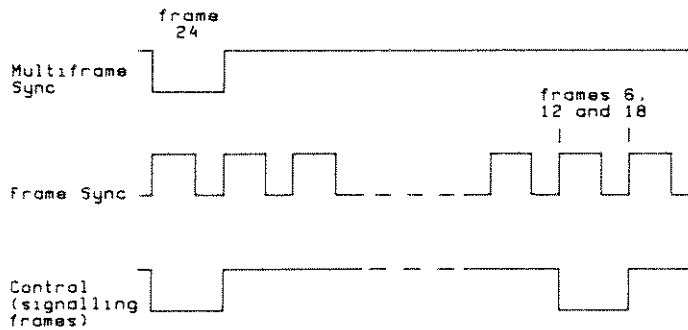

The output with CCS operation is a constant false (high) level.

APPENDIX G

Coded Selectable Filters

CODED SELECTABLE FILTERS

This table provides details of the filters which are defined by coded displays.

Filter Codes

Measurement	FILTER A (ascii 65)	FILTER B (ascii 66)	FILTER C (ascii 67)
LEVEL "OTHER FILTERS"	3kHz flat	dc block high pass	channel filter test filter 4.1 to 4.6kHz high pass
IDLE STATE "OTHER FILTERS"	3kHz flat	dc block high pass	channel filter test filter 4.1 to 4.6kHz high pass
TRANSIENTS- * IMPULSES	C-MESSAGE and 1010Hz notch fixed		
PHASE JITTER	20 to 300Hz	4 to 300Hz	

\*OPTION 002 FILTER A = 200Hz high pass with 1010Hz notch  
 FILTER B = 600Hz to 3kHz with 1010Hz notch  
 FILTER C = 300Hz to 500Hz

In other measurements the weighted filter  
 is psophometric.



APPENDIX H  
ERROR CODES

ERROR CODES

Abbreviations      AN analog  
                          DIG digital  
                          meas measurement  
                          Rx receiver  
                          Tx transmitter  
                          BDFA HP-IB binary data list  
                          (See IEEE 728)  
                          crc cyclic redundancy code

ERROR CODE	ERROR INDICATED	ERROR CODE	ERROR INDICATED
<b>OPERATING/PROGRAMMING ERRORS</b>			
1	Incorrect HP-IB command string syntax	22	Format parameter in OH OR or OT command is undefined
2	HP-IB command string too long	23	HP-IB interface error, Addressed to talk but no listeners present
3	Unrecognised HP-IB command	24	Rear panel switch changed when running
4	HP-IB command parameter out of range	25	Parameter out of range during run time
5	HP-IB command parameter missing	26	Provided for factory service
6	Too many command parameters	27	Not used
7	Unsupported block data format	28	Provided for factory service
8	Zero or negative byte count in BDFA data list	29	Not used
9	Byte count in BDFA data list is greater than the number of subsequent bytes	30	No clock for DIG Tx, check rear panel EXT CLOCK switch
10	Odd number of bytes in binary format data list	31	Loss of DIG Rx alignment/signal
11	Command ignored, instrument in local	32	No DIG Rx signal/alignment in THRU PCM mode, or suspect synthesiser clock because of alignment loss For analog operation SYNTH PCM must be selected
12	HP-IB command out of context	33	AN I/P level too high
13	Meas not defined for this instrument	34	Signal too small to measure
14	Meas not available in current mode	35	Signal too unstable for autorange
15	Option hardware not present for this meas	36	AN Rx overloaded following auto-range, signal too unstable
16	Incorrect PCM format for framing/ signalling meas selected	37	DIG filter overload, signal level too high or too unstable
17	Channel 31 requested with 30 channel format selected (rear panel switch)	38	Rx level too low to measure in reference section of meas
18	Add to sequence failed: meas cannot be sequenced, mode not back to back (ie A-A, D-A, A-D or D-D)	39	No modulation envelope present for delay meas
19	Add to sequence failed: not enough room in memory	40	Group delay carrier changeover irrecoverable, group delay signal may not be present
20	Recall from sequence failed: no sequence present or beyond end of sequence	41	DIG filter overload during settling group delay signal may not be suitable.
21	Recall mask failed: no mask stored for this meas		

ERROR CODE	ERROR INDICATED	ERROR CODE	ERROR INDICATED
42	Group delay sync loss, reference level too low or no 166Hz burst	99	Transient power failure detected
43	Meas section of group delay waveform is too small		<b>POWER-ON SELF TEST ERRORS</b>
44	Coder offset too great (outside bottom two segments), or >3276 expanded code steps	100	Processor memory fault
45	Power failure recovery, significant in transients, remod etc.	101	ROM or rom version number not present
46	Impulse threshold out of range because Rx signal level is too high or too low	102	ROM crc check failure
47	Group delay level too low,	103	Processor peripheral interface adaptor faulty
48, 49	Not used	104	Multiple interrupt requests from keyboard during keyboard test
	<b>MEASUREMENT SOFTWARE FAULTS</b>	105	Display bus test timeout
50	Repeat the operation to confirm the fault	106	Display ram test failure
::	These codes are provided for factory service purposes	107	Instrument bus test timeout
69	Details are given in the service manual	108	Instrument bus read/write test failure
	<b>CALIBRATION ERRORS</b>	109	Instrument bus hardware fault
70	Repeat the operation to confirm the error condition	110	Instrument bus timeout detection inoperative
::	These codes are provided for factory service purposes	111	-117 non-volatile memory test failures
79	Details are given in the service manual	111	Power-on defaults crc check failure
	<b>MEASUREMENT HARDWARE FAULTS</b>	112	Stored masks crc check failure
80	Primary autorange hardware fault	113	Measurement sequence crc check failure
81	Secondary autorange timeout	114	Dual tone multi-frequency dialing table crc check failure
82	Secondary autorange analog input high	115	NVM incorrect for this instrument
83	Secondary autorange hardware fault	116	NVM ram test failure
84	Secondary autorange analog input level too low	117	ROM mapping failure, possible faulty ram
85	Loss of sync between AN Rx and digital filter	118	Group delay/plot results list ram faulty
86	Loss of sync between DIG Rx and digital filter	119	Memory assembly faulty, do not continue
87	No digital filter handshake for more than 2ms	120	Configuration not saved at last power-down, will always occur when the A13 processor assy reset button is pressed
88	Digital filter 28 bit hardware overflow	121	Unable to restart power-fail protected measurement. inconsistent configuration. probably rear panel switches have been changed
89	Group delay frequency counter overflow	130	-137 digital filter self test errors (these affect both AN Rx and DIG Rx)
90	Option A/D converter failed to convert, data ready flag read 20 times.	130	Error in down loading program
91	Digital receiver timeout	131	LDATAREADY (status sign bit) at incorrect rate
92	Digital receiver not programming correctly	132	Input bus error
93 /94	Not used	133	Unable to clear data ram
95	HP-IB IC has misplaced an SRQ	134	Failed to increment carry-out counter
96	Spurious or untraceable interrupt	135	Digital filter hardware fault
97	Display bus timeout	136	Digital filter hardware fault
98	Instrument bus timeout		<b>SYSTEM SOFTWARE ERRORS</b>
		200	Repeat the operation to confirm the error
		::	These codes are provided for factory service purposes
		214	

## INDEX

Accessories available . . . . .	1-3
Accessories supplied . . . . .	1-3
Analog Rx impedance . . . . .	3-17
Analog Tx impedance . . . . .	3-17
Auxiliary input for level measurements . . . . .	4-15
Auxiliary input . . . . .	5-9
Background PCM selection, example . . . . .	3-13
Background PCM selection . . . . .	4-6
Battery, internal . . . . .	2-10
Calibration, automatic . . . . .	appendix D
Clock errors, all modes . . . . .	appendix E
CODE AMI(AZS)/B8ZS selection . . . . .	4-5
CODED SELECTABLE FILTERS . . . . .	appendix G
Communication over the line under test . . . . .	4-15, appendix D
Connectors, mating . . . . .	2-3
CONTROL kyes, example . . . . .	3-11
Data valid output, selected timeslot/framing and signalling . . . . .	appendix F
Data valid, PCM bit pattern, Rx clock relationship . . . . .	appendix F
dBm definition . . . . .	appendix A
dBm0 definition . . . . .	appendix A
dBm0p definition . . . . .	appendix A
dBr definition . . . . .	appendix A
dBrn0 definition . . . . .	appendix A
dBrnC0 definition . . . . .	appendix A
DELETE function, example . . . . .	3-10
Deletion of measurement points . . . . .	4-36
DIG Rx DATA OUTPUT . . . . .	appendix F
Digital Rx data output (rear panel connector) . . . . .	2-9
End to end operation . . . . .	5-1, 5-6
ERROR CODES . . . . .	appendix H
External clock . . . . .	5-9
Features available . . . . .	1-3
Filter selection, level/idle state, other filters . . . . .	3-17
Filters A, B and C identification . . . . .	appendix G
Foreground PCM selection, example . . . . .	3-15
FRAME FORMAT normal/extended selection . . . . .	4-5
Frame sync output . . . . .	appendix F
Framing and signalling bit selection . . . . .	4-5
Framing and signalling bits . . . . .	4-30
Framing and signalling bits HP-IB . . . . .	6-19
GENERAL INFORMATION . . . . .	SECTION 1
GETTING STARTED . . . . .	SECTION 3
Holding Tone . . . . .	6-12, appendix E
HP-IB ? form of commands, validity . . . . .	6-5
HP-IB ? form of commands, general . . . . .	6-3
HP-IB background idle code selection . . . . .	6-11
HP-IB balanced/unbalanced, analog transmitter . . . . .	6-10
HP-IB capability IEEE488 . . . . .	6-1
HP-IB capability IEEE728 . . . . .	6-1
HP-IB command categories . . . . .	6-3

HP-IB commands, examples . . . . .	6-3
HP-IB commands, general information . . . . .	6-2
HP-IB configuration commands, general information . . . . .	6-3
HP-IB connector . . . . .	2-6
HP-IB continuous pulse signalling . . . . .	6-23
HP-IB data output commands, general information . . . . .	6-4
HP-IB data output command . . . . .	6-21
HP-IB device clear . . . . .	6-2
HP-IB device identification . . . . .	6-9
HP-IB dial via signalling . . . . .	6-23
HP-IB dialling commands . . . . .	6-22
HP-IB digital receive termination . . . . .	6-11
HP-IB error output . . . . .	6-21
HP-IB frame format normal/extended selection . . . . .	6-10
HP-IB framing and signalling bit selection . . . . .	6-10
HP-IB function/number of parameters required . . . . .	6-5
HP-IB function/validity table . . . . .	6-5
HP-IB holding tone . . . . .	6-12
HP-IB identification output . . . . .	6-21
HP-IB idle cal disable/enable selection . . . . .	6-12
HP-IB idle state (instrument) . . . . .	6-12
HP-IB impedance, analog receiver . . . . .	6-10
HP-IB impedance, analog transmitter . . . . .	6-10
HP-IB Immediate execution commands, general information . . . . .	6-3
HP-IB INFORMATION . . . . .	SECTION 6
HP-IB input/output data formats . . . . .	6-7
HP-IB installation . . . . .	2-6
HP-IB instrument configuration commands . . . . .	6-10
HP-IB instrument status commands . . . . .	6-8
HP-IB internal/external clock selection . . . . .	6-10
HP-IB key codes, quick reference . . . . .	6-6
HP-IB local lockout . . . . .	6-2
HP-IB loudspeaker volume . . . . .	6-12
HP-IB measurement configuration commands . . . . .	6-13
HP-IB measurement parameter output . . . . .	6-9
HP-IB measurements---see measurements	
HP-IB messages . . . . .	6-2
HP-IB mnemonic listing . . . . .	6-5
HP-IB multifrequency dialling tones . . . . .	6-22
HP-IB multifrequency dialling . . . . .	6-23
HP-IB network delay time . . . . .	6-12
HP-IB operating mode selection . . . . .	6-11
HP-IB output formats(rear panel switches) . . . . .	2-8
HP-IB PCM code AMI(AZS)/B&ZS selection . . . . .	6-10
HP-IB PCM format . . . . .	6-10
HP-IB provide status output . . . . .	6-8
HP-IB recall measurement mask . . . . .	6-20
HP-IB remote enable . . . . .	6-2
HP-IB repeat command . . . . .	6-20
HP-IB report errors . . . . .	6-9
HP-IB result error output . . . . .	6-21
HP-IB result header output . . . . .	6-21



HP-IB result output . . . . .	6-21
HP-IB result trailer output . . . . .	6-21
HP-IB running measurements . . . . .	6-20
HP-IB selective device clear . . . . .	6-2
HP-IB self test commands . . . . .	6-24
HP-IB sequence commands . . . . .	6-21
HP-IB sequence, add command . . . . .	6-21
HP-IB sequence, clear command . . . . .	6-21
HP-IB sequence, number of measurements enquiry . . . . .	6-21
HP-IB serial poll . . . . .	6-2
HP-IB signalling CCS/CAS selection . . . . .	6-10
HP-IB signalling bit dialling parameter setting . . . . .	6-23
HP-IB single frequency dialling . . . . .	7-1
HP-IB single step command . . . . .	6-20
HP-IB SRQ disable/enable . . . . .	6-10
HP-IB SRQ mask selection . . . . .	6-8
HP-IB status bytes . . . . .	6-25
HP-IB stop command . . . . .	6-21
HP-IB store measurement mask . . . . .	6-20
HP-IB synthesised/thru PCM selection . . . . .	6-10
HP-IB terminated/bridged, analog receiver . . . . .	6-10
HP-IB timeslot digital receive . . . . .	6-12
HP-IB timeslot translation . . . . .	6-10
HP-IB timeslot(s) digital transmit . . . . .	6-11
HP-IB TLP, analog receive . . . . .	6-11
HP-IB TLP, analog transmit . . . . .	6-11
Holding tone . . . . .	6-12, appendix E
Impedance, see Interface	
Incomplete HP-IB data list read "hang up" . . . . .	appendix E
Incorrect background PCM in idle state weighted . . . . .	appendix E
Incorrect operation, framing/signalling/background PCM . . . . .	appendix E
Incorrect results for end to end measurements . . . . .	appendix E
Incorrect results in analog gain/level measurements . . . . .	appendix E
Inoperative keys . . . . .	appendix E
Inoperative timeslot translation . . . . .	appendix E
INSERT function, example . . . . .	3-9
Insertion of measurement points . . . . .	4-36
Inspection, initial . . . . .	2-1
INSTALLATION . . . . .	SECTION 2
Instrument description . . . . .	1-2
Instruments covered by manual . . . . .	1-1
Interface setting, analog receiver impedance, bridged/terminated . . . . .	4-3
Interface setting, analog receiver TLP . . . . .	4-3
Interface setting, analog transmitter impedance, bal/unbal . . . . .	4-3
Interface setting, analog transmitter TLP . . . . .	4-3
Interface setting, digital receiver terminated/monitor . . . . .	4-4
Interface setting, digital receiver timeslot . . . . .	4-5
Interface setting, digital transmitter PCM, synth/thru . . . . .	4-4
Interface setting, digital transmitter timeslot(s) . . . . .	4-4
Intermodulation distortion 4-tone . . . . .	3-17
Keys inoperative . . . . .	appendix E
Loopback operation . . . . .	5-1

Loopthrough, PCM . . . . .	4-2
MANUAL UPDATE . . . . .	SECTION 7
Mating connectors . . . . .	2-3
Measurement configuration examples . . . . .	5-2/5-8
Measurement detail information, key . . . . .	4-7
MEASUREMENT MODES AND CONFIGURATIONS . . . . .	SECTION 5
Measurement selection . . . . .	4-7
Measurement sequences . . . . .	4-40
Measurement/specification index . . . . .	1-5
MEASUREMENTS . . . . .	SECTION 4
Measurements, Absolute delay . . . . .	4-26
Measurements, Absolute delay HP-IB . . . . .	6-19
Measurements, CRC bits . . . . .	4-32
Measurements, CRC bits HP-IB . . . . .	6-20
Measurements, Dialling . . . . .	4-27
Measurements, Dialling HP-IB . . . . .	6-20
Measurements, Digital Tx-Rx . . . . .	4-9
Measurements, Digital Tx-Rx HP-IB . . . . .	6-13
Measurements, Envelope delay distortion . . . . .	4-23
Measurements, Envelope delay distortion HP-IB . . . . .	6-18
Measurements, Fe bits (extended frame) . . . . .	4-31
Measurements, Fe bits HP-IB . . . . .	6-20
Measurements, Fs bits . . . . .	4-31
Measurements, Fs bits HP-IB . . . . .	6-19
Measurements, Ft bits (normal frame) . . . . .	4-31
Measurements, Ft bits HP-IB . . . . .	6-19
Measurements, Gain dig mW . . . . .	4-8
Measurements, Gain dig mW HP-IB . . . . .	6-13
Measurements, Gain tone . . . . .	4-8
Measurements, Gain tone HP-IB . . . . .	6-13
Measurements, Gain v frequency . . . . .	4-10
Measurements, Gain v frequency HP-IB . . . . .	6-17
Measurements, Gain v level tone . . . . .	4-11
Measurements, Gain v level 2kHz sync . . . . .	4-12
Measurements, Gain v level 2kHz sync HP-IB . . . . .	6-16
Measurements, Idle state other filters . . . . .	4-15
Measurements, Idle state other filters HP-IB . . . . .	6-16
Measurements, Idle state PCM codes (coder offset) . . . . .	4-14
Measurements, Idle state PCM codes (coder offset) HP-IB . . . . .	6-16
Measurements, Idle state selective . . . . .	4-14
Measurements, Idle state selective HP-IB . . . . .	6-15
Measurements, Idle state weighted filter . . . . .	4-13
Measurements, Idle state weighted filter HP-IB . . . . .	6-16
Measurements, Intermod 2 tone . . . . .	4-21
Measurements, Intermod 2 tone HP-IB . . . . .	6-17
Measurements, Intermod 4 tone . . . . .	4-20
Measurements, Intermod 4 tone HP-IB . . . . .	6-17
Measurements, Level PCM codes . . . . .	4-18
Measurements, Level PCM codes HP-IB . . . . .	6-15
Measurements, Level other filters . . . . .	4-19
Measurements, Level other filters HP-IB . . . . .	6-15
Measurements, Level selective . . . . .	4-17

Measurements, Level selective HP-IB . . . . .	6-14
Measurements, Level weighted filter . . . . .	4-16
Measurements, Level weighted filter HP-IB . . . . .	6-14
Measurements, Loop timing . . . . .	4-32
Measurements, Loop timing HP-IB . . . . .	6-18
Measurements, Notched noise . . . . .	4-13
Measurements, Notched noise HP-IB . . . . .	6-17
Measurements, Phase jitter . . . . .	4-33
Measurements, Phase jitter HP-IB . . . . .	6-19
Measurements, Quantising distortion . . . . .	4-22
Measurements, Quantising distortion HP-IB . . . . .	6-17
Measurements, Remod . . . . .	4-25
Measurements, Remodulation HP-IB . . . . .	6-19
Measurements, Return Loss (4W) . . . . .	4-27
Measurements, Return loss (4W) HP-IB . . . . .	6-18
Measurements, Sig bits . . . . .	4-32
Measurements, Sig bits HP-IB . . . . .	6-20
Measurements, Transients . . . . .	4-28
Measurements, Transients HP-IB . . . . .	6-18
Measurements, throw clear index/valid modes . . . . .	4-8
Monitor output . . . . .	5-9
Multi point measurement operation, example . . . . .	3-7
Multiframe sync output . . . . .	appendix F
Non-volatile memory . . . . .	4-42
NOTES ON MEASUREMENT CONTROL . . . . .	6-26
Operating environment . . . . .	2-3
Operating mode selection . . . . .	4-2
OPERATIONAL TROUBLESHOOTING . . . . .	appendix E
Options . . . . .	1-4
PCM bit pattern output . . . . .	appendix F
PCM format selection . . . . .	4-5
PCM FRAME STRUCTURE . . . . .	appendix B
Parameter changing, multi point example . . . . .	3-8
Parameter changing, single point example . . . . .	3-6
Parameters selection . . . . .	4-34
Parameters, changing in multipoint measurements . . . . .	4-34
PLOTTER CONFIGURATIONS (rear panel switches) . . . . .	appendix C
Plotter output . . . . .	5-9
Power cable . . . . .	2-2
Power requirements . . . . .	2-2
Preparation for use . . . . .	2-1
Print format switch settings (plotter configurations) . . . . .	appendix C
Print/plot output formats . . . . .	2-8
Printer output . . . . .	5-9
Rack mounting . . . . .	2-5
RECALL, function example . . . . .	3-6
RECALL function . . . . .	4-37
Safety information . . . . .	2-1
Selection of measurements inhibited . . . . .	appendix E
SELF TEST . . . . .	appendix D
Self test 18 failure . . . . .	appendix E
Sequences containing continuous measurements . . . . .	4-41

Sequences . . . . .	3-17
SEQUENCE operation . . . . .	4-40
Shipment . . . . .	2-9
SIGNALLING CAS/CCS selection . . . . .	4-5
Single point measurement running, example . . . . .	3-5
SPEAKER key, example . . . . .	3-11
Specification/measurement index . . . . .	1-5
Specifications . . . . .	1-6
Storage . . . . .	2-9
STORE function . . . . .	4-37
STORE, function example . . . . .	3-6
Store and recall framing, signalling and background PCM . . . . .	4-38
Store and recall user defined interface default parameters . . . . .	4-39
Store/recall user defined parameters . . . . .	4-37
Switch on, default state . . . . .	3-2
Switch on, instrument routine . . . . .	3-2
Talk only configuration . . . . .	2-7
Timeslot 16 upper/lower nibble indicator . . . . .	appendix F
Timeslot Rx selection, example . . . . .	3-14
Timeslot selection, also see Interface	
TIMESLOT TRANSLATION . . . . .	4-6
Timeslot translation inoperative . . . . .	appendix E
Timeslot(s) Tx selection, example . . . . .	3-14
TLP, also see Interface	
TLP definition . . . . .	appendix A
TLP, effect on gain/level measurements . . . . .	3-6
TLP, Rx setting example . . . . .	3-5
TLP, Tx setting example . . . . .	3-4
Transients . . . . .	3-17
UNITS, DEFINITIONS . . . . .	appendix A
UPDATE INFORMATION . . . . .	7-1