Parameter Analyzer

Quick Start Guide

© Copyright Hewlett-Packard Company 1993

All Right Reserved.

Reproduction, adaptation, or translation without prior written permission is prohibited, except as allowed under the copyright laws.

HP Part Number

04155-90200

First edition, September 1993

Printed in Japan

Product Warranty

This Hewlett-Packard product is warranted against defects in material and workmanship for a period of one year from date of shipment. During the warranty period, Hewlett-Packard will, at its option, either repair or replace products which prove to be defective.

Warranty service of this product will be performed at Buyer's facility at no charge within Hewlett-Packard service travel areas. Outside Hewlett-Packard service travel areas, warranty service will be performed at Buyer's facility only upon Hewlett-Packard's prior agreement and Buyer shall pay Hewlett-Packard's round trip travel expenses. In all other cases, products must be returned to a service facility designated by Hewlett-Packard.

For products returned to Hewlett-Packard for warranty service, Buyer shall prepay shipping charges to Hewlett-Packard and Hewlett-Packard shall pay shipping charges to return the product to Buyer. However, Buyer shall pay all shipping charges, duties, and taxes for products returned to Hewlett-Packard from another country.

Hewlett-Packard warrants that its software and firmware designated by Hewlett-Packard for use with an instrument will execute its programming instructions when properly installed on that instrument. Hewlett-Packard does not warrant that the operation of the instrument, or software, or firmware will be uninterrupted or error free.

Limitation of Warranty

The foregoing warranty shall not apply to defects resulting from improper or inadequate maintenance by Buyer, Buyer-supplied software or interfacing, unauthorized modifications or misuse, operation outside of the environment specifications for the products, or improper site preparation or maintenance.

No other warranty is expressed or implied. Hewlett-Packard specifically disclaims the implied warranties of merchantability and fitness for a particular purpose.

Exclusive Remedies

The remedies provided herein are the Buyer's sole and exclusive remedies. Hewlett-Packard shall not be liable for any direct, indirect, special, incidental, or consequential damages, whether based on contract, tort, or any other legal theory.

Assistance

Product maintenance agreements and other customer assistance agreements are available for Hewlett-Packard products.

For any assistance, contact your nearest Hewlett-Packard Sales Office.

Certification

Hewlett-Packard Company certifies that this product met its published specifications at the time of shipment [from the factory]. Hewlett-Packard further certifies that its calibration measurements are traceable to the **National Institute of Standards and Technology** [NIST], to the extent allowed by the Institute's calibration facility, and to the calibration facilities of other International Standards Organization members.

Yokogawa-Hewlett-Packard, Ltd.

9-1, Takakura-cho, Hachioji-shi, Tokyo 192 Japan

HP 4155A and HP 4156A

HP 4155A Semiconductor Parameter Analyzer and HP 4156A Precision Semiconductor Parameter Analyzer are full automatic and high performance instruments designed to measure, to display graphically, and to analyze the dc parameters and characteristics of semiconductor devices such as diodes, transistors, ICs, solar cells, and wafers during the fabrication process. So you can evaluate device design, process design, fabrication environments, and so on with the HP 4155A/4156A.

In semiconductor research and development laboratories, the HP 4155A/4156A provides precise characteristics evaluation, which is an important step in the development of new high performance devices, and gives design engineers an easy to use method of device parameter acquisition—an essential element in computer aided design (CAD).

On the production line, the HP 4155A/4156A provides real-time feedback on wafer evaluation to improve the semiconductor process and to increase production yields.

For semiconductor end users, the HP 4155A/4156A is ideal for circuit design applications and incoming inspection.

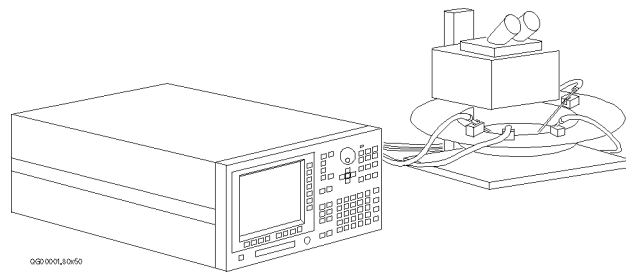

HP 4155A/4156A—At a Glance

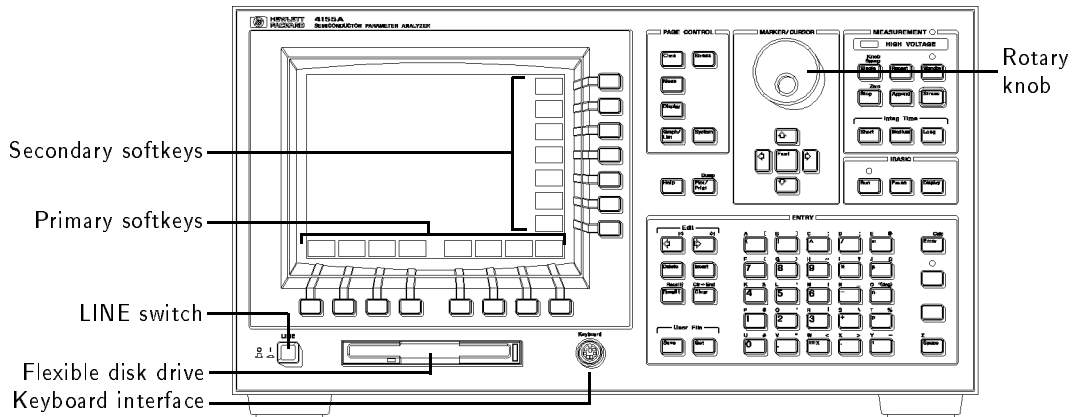

- | | |
|---------------------|---|
| LINE switch | You use the LINE switch to apply electric power. |
| Flexible disk drive | You can use 3.5-inch diskette as the mass storage, which is inserted in this flexible disk drive. |
| Keyboard interface | You can control the HP 4155A/4156A from keyboard, which is connected to the keyboard interface, as well as from the front-panel keys. |
| Primary softkeys | You use primary softkeys to move pages and to change the secondary softkey menu. |
| Secondary softkeys | You use secondary softkeys to select variable names, alternatives, and changing items. |
| Rotary knob | You use rotary knob to change the setting value and to move a marker. |

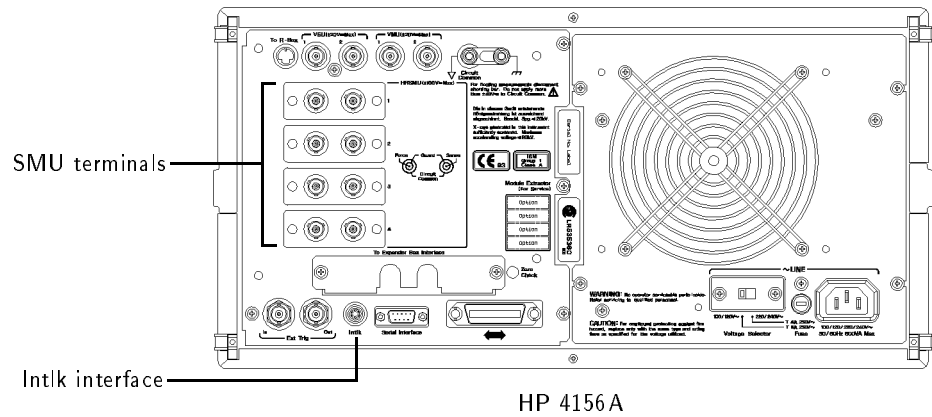
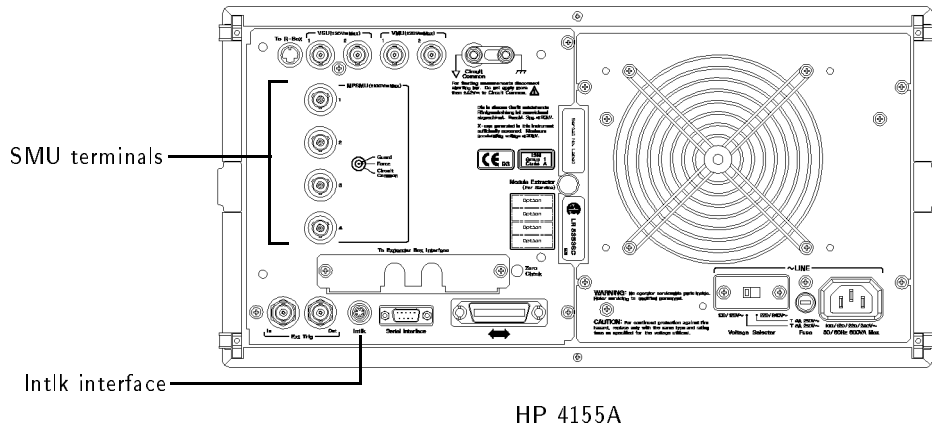

SMU terminals

Either voltage or current output is forced from the SMU terminals, and measurement signal is put to the SMU terminals.

Intlk interface

To prevent you from electric shock, the HP 4155A/4156A has interlock function. The signals for the interlock function go through the Intlk interface.

In This Guide Book

This guide book is a quick start guide for HP 4155A and HP 4156A. It introduces a basic measurement and its analysis without a lot of explanation and details. You can perform the following measurement and analysis through this guide book:

- Measuring $V_g - \sqrt{I_d}$ characteristics of a MOS FET.
- Analyzing its graph and finding threshold voltage (V_{th}).

You will find quick instructions for starting measurements with an HP 4155A/4156A.

Key Conventions.

The following key conventions are used in this guide:

Front-panel key	Text shown like this represents a key physically located on the HP 4155A/4156A.
Softkey	Text shown like this represents a softkey.
Screen Text	Text printed in this typeface indicates text displayed on the HP 4155A/4156A.
Bold	Text shown like this indicates a term defined in the glossary.
<i>Italic</i>	Text shown like this refers to a related document, or is used for emphasis.

Finding Further Information.

This guide book is written for beginners of HP 4155A/4156A. See the following books for further information on the HP 4155A/4156A:

HP 4155A/4156A User's Guide (HP part number 04155-90000) provides information on how to use the HP 4155A/4156A.

HP 4155A/4156A Programmer's Guide (HP part number 04155-90100) provides information on how to control the HP 4155A/4156A with remote commands.

HP Instrument BASIC Users Handbook (HP part number E2083-90000) provides information on how to use HP Instrument BASIC, which is programming language built-in the HP 4155A/4156A.



Getting Started

Getting Started

This guide introduces how to use HP 4155A Semiconductor Parameter Analyzer and HP 4156A Precision Semiconductor Parameter Analyzer. Basic operations of the HP 4155A/4156A are provided.

This guide consists of the following three sections:

- **Making a measurement:** preparing for measurements and measuring a sample device (MOS FET).
- **Analyzing a result:** analyzing the results graphically and searching for the threshold voltage (V_{th}) of the MOS FET.
- **If you have a problem:** providing solutions to problems you may encounter while using this guide.

Before going to the next page, make sure you have prepared the following:

- HP 4155A or HP 4156A
- HP 16442A test fixture
- Test device (n-channel MOS FET, enhancement type)
In this guide, the test device used is a Siliconix SD214DE.

This guide book assumes that you have already installed your HP 4155A/4156A. If not, refer to “Installation” in the *HP 4155A/4156A User's Task Guide*.

Making a Measurement

In this section, you learn how to execute the measurements with an HP 4155A/4156A and to display the measurement results graphically. Id-Vg measurement of a MOS FET is provided as an example. You learn step-by-step how to perform this measurement.

You measure the device under test (DUT) by using the measurement circuit as shown in the following diagram. SMU2 and SMU3 sweep the same voltage to the gate and drain. SMU3 measures the drain current (Id). The source and substrate are connected to circuit common.

You should get result similar to the following figure. Gate voltage V_g (swept from 0 V to 2 V) is assigned to X axis, $\sqrt{I_d}$ is assigned to Y1 axis, and $\frac{\partial}{\partial V_g} \sqrt{I_d}$ is assigned to Y2 axis.

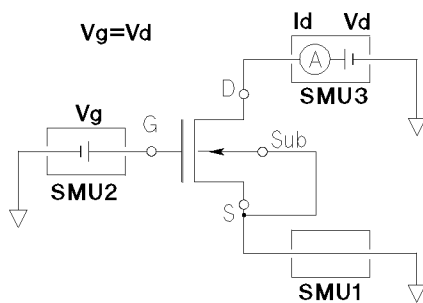

QG01024,145x60

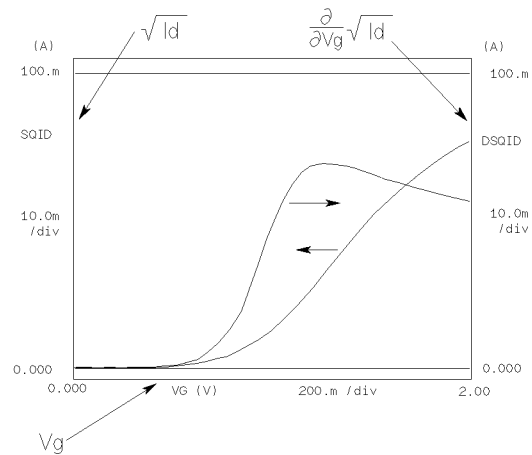

Step 1. Prepare for the measurement

Before executing measurement, configure HP 4155A/4156A and accessories.

1. Make sure that the HP 4155A/4156A is off.
2. Connect the HP 16442A test fixture to HP 4155A/4156A. See next figure.
3. If you use the keyboard, connect it to the HP 4155A/4156A.

When you use the HP 4155A, connect as follows:

HP 4155A	cable	HP 16442A	HP 4155A	cable	HP 16442A
Intlk	⇐Interlock/LED ¹ ⇒	Intlk	VSU 1	⇐Coaxial ³ ⇒	VSU 1
SMU 1	⇐Triaxial ² ⇒	SMU 1 blue label	VSU 2	⇐Coaxial ³ ⇒	VSU 2
SMU 2	⇐Triaxial ² ⇒	SMU 2 blue label	VMU 1	⇐Coaxial ³ ⇒	VMU 1
SMU 3	⇐Triaxial ² ⇒	SMU 3 blue label	VMU 2	⇐Coaxial ³ ⇒	VMU 2
SMU 4	⇐Triaxial ² ⇒	SMU 4 blue label			

1 Interlock/LED cable: HP 16493J

2 Triaxial cable: HP 16493C. You do not need to connect SMU4 for this measurement.

3 Coaxial cable: HP 16493B. You do not need to connect VSUs and VMUs for this measurement.

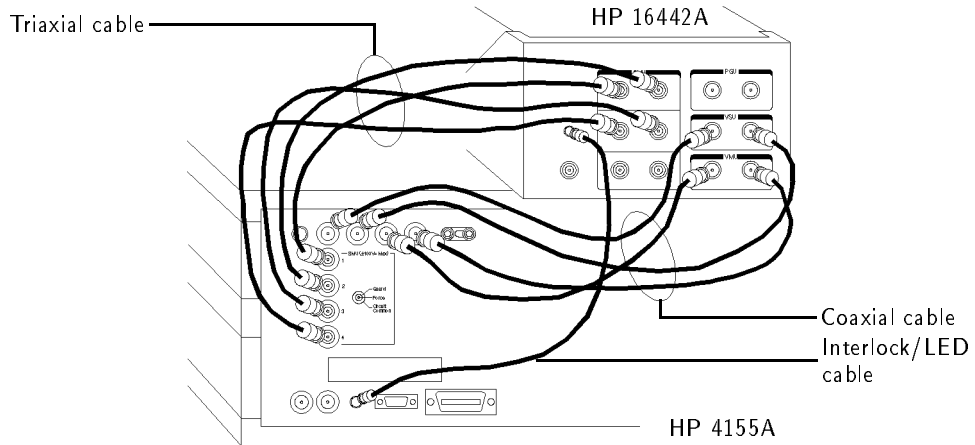

Connecting HP 4155A to HP 16442A Test Fixture

When you use the HP 4156A, connect as follows:

HP 4156A	cable	HP 16442A	HP 4156A	cable	HP 16442A
Intlk	↔ Interlock/LED ¹ ↔	Intlk	VSU 1	↔ Coaxial ³ ↔	VSU 1
SMU 1	↔ Kelvin triaxial ² ↔	SMU 1	VSU 2	↔ Coaxial ³ ↔	VSU 2
SMU 2	↔ Kelvin triaxial ² ↔	SMU 2	VMU 1	↔ Coaxial ³ ↔	VMU 1
SMU 3	↔ Kelvin triaxial ² ↔	SMU 3	VMU 2	↔ Coaxial ³ ↔	VMU 2

- 1 Interlock/LED cable: HP 16493J
- 2 Kelvin triaxial cable: HP part number 04155-61602
- 3 Coaxial cable: HP 16493B. You do not need to connect VSUs and VMUs for this measurement.

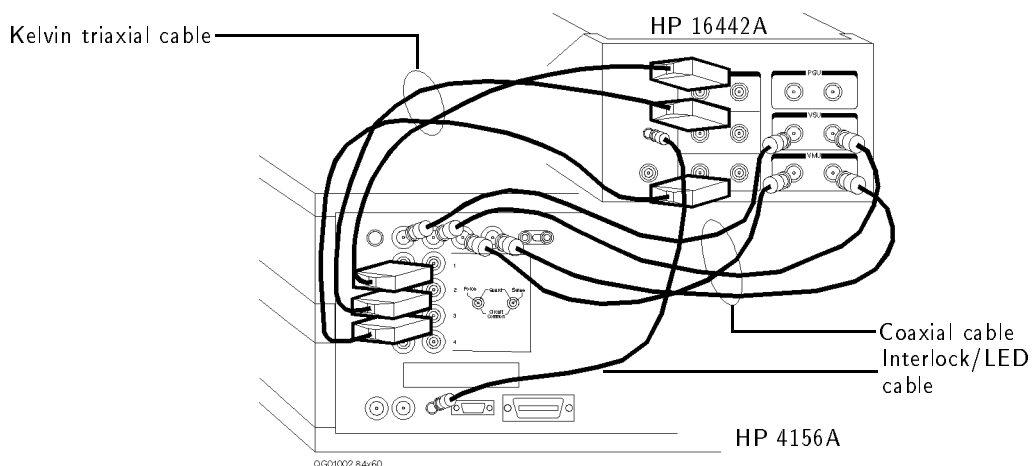

Connecting HP 4156A to HP 16442A Test Fixture

Step 2. Mount your DUT on the test fixture

1. Select a suitable socket module for your DUT.
2. Mount the socket module on the test fixture.

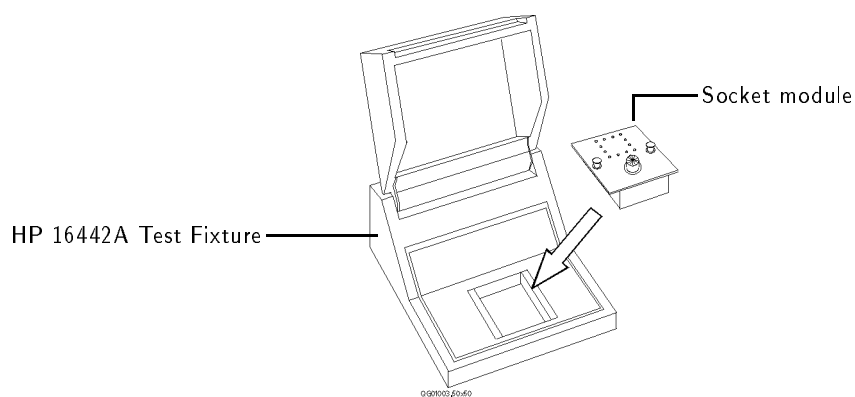

3. Mount your DUT on the socket module.
4. Make connections with four connection cables (miniature banana - pin plug).

You make the following connections:

Source—SMU1
Gate—SMU2
Drain—SMU3
Substrate—SMU1

Both the source and substrate terminals are connected to SMU1.

5. After finishing connections, shut the lid of the test fixture.

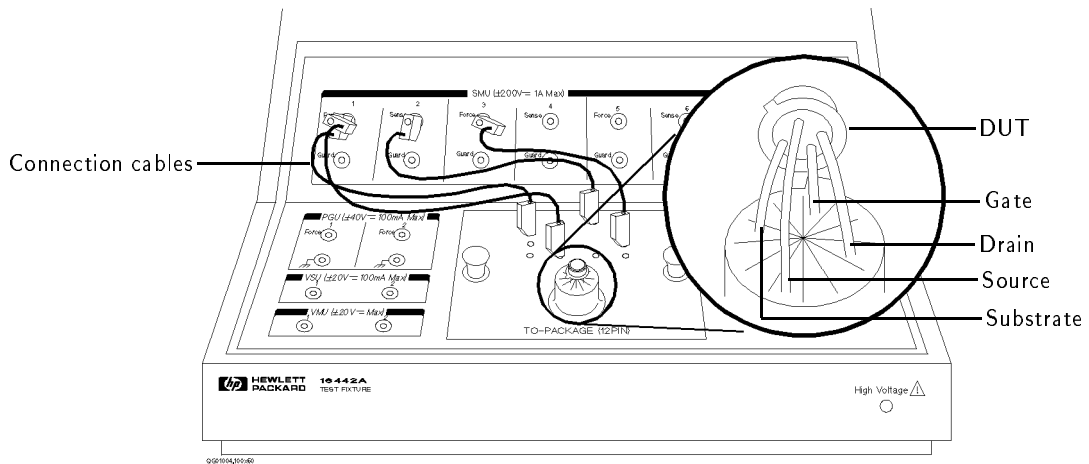

Wiring for HP 4155A

For this measurement by the HP 4156A, non-Kelvin connections are used. So, connect only the force terminals as shown in the following figure:

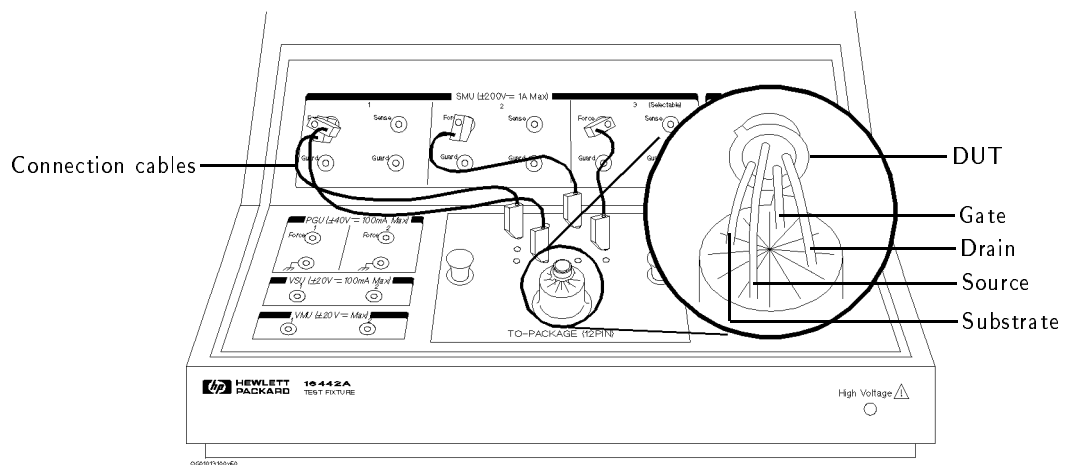

Wiring for HP 4156A

Step 3. Define the channel assignments

You set the connection information on the CHANNELS: CHANNEL DEFINITION page.

1. Switch on the HP 4155A/4156A. Self-test starts.
2. After self-test is finished, make sure that CHANNELS: CHANNEL DEFINITION page appears on the screen of the HP 4155A/4156A. If not, press **(Chan)** front-panel key.

CHANNELS: CHANNEL DEFINITION page

MEASUREMENT MODE

Secondary softkeys

Primary softkeys

*CHANNELS		MEASURE				STBY	SERIES
UNIT	VNAME	I/NAME	MODE	FCTN		RESISTANCE	
SMU1:MP	V1	I1	COMMON	CONST		0 ohm	
SMU2:MP	V2	I2	I	VAR2		0 ohm	
SMU3:MP	V3	I3	V	VAR1			
SMU4:MP	V4	I4	V	CONST			
VSU1	VSU1	-----	V	CONST			
VSU2	VSU2	-----	V	CONST			
VMU1	VMU1	-----	V	-----	----		
VMU2	VMU2	-----	V	-----	----		

SWEET

CHANNEL DEF USER FCTN B NEXT PAGE

3. Make sure that **SWEEP** is displayed in the MEASUREMENT MODE field. If not, select **SWEEP** secondary softkey in the MEASUREMENT MODE field.
4. Set the connection information in the CHANNELS table as follows:

*CHANNELS						SERIES RESISTANCE
UNIT	VNAME	INAME	MODE	FCTN	STBY	
SMU1:MP	VS	IS	COMMON	CONST		0 ohm
SMU2:MP	VG	IG	V	VAR1'		0 ohm
SMU3:MP	VD	ID	V	VAR1		
SMU4:MP						
VSU1		-----				
VSU2		-----				
VMU1		-----				
VMU2		-----				

0601006,7b/40

Action	on Front Panel	on Keyboard
To move the pointer,	use , , , or of MARKER/CURSOR area.	use , , , or .
To move the cursor to edit in display area,	use or of Edit area.	use Backspace key.
To enter "VS" in VNAME field,	press V , S \, then Enter .	type VS , then press Enter .
To enter "IS" in INAME field,	press I ? , S \, then Enter .	type IS , then press Enter .
To set "V" in the MODE field,	select V secondary softkey.	press Shift F1 keys.
To set "VAR1'" in FCTN field,	select VAR1' secondary softkey.	press Shift F4 keys.
To set "VAR1" in FCTN field,	select VAR1 secondary softkey.	press Shift F2 keys.
To disable a unit,	select DISABLE UNIT secondary softkey.	press Shift F7 keys.

Step 4. Define the user functions

You define the user functions on the CHANNELS: USER FUNCTION DEFINITION page.

1. Select **USER FCTN** primary softkey. The CHANNELS: USER FUNCTION DEFINITION page appears.
2. Enter the user function information in the table as follows:

CHANNELS: USER FUNCTION DEFINITION page

NAME	UNIT	DESCRIPTION
SQID	A	SQRT(ID)
DSQID	A	DIFF(SQID,VG)

DELETE ENTRY

DISABLE FUNCTION

CHANNEL DEF USER FCTN PREV PAGE NEXT PAGE

You enter the following two user functions:

$$SQID = \sqrt{Id}$$

$$DSQID = \frac{\partial}{\partial Vg} SQID = \frac{\partial}{\partial Vg} \sqrt{Id}$$

Where, Id is drain current and Vg is gate voltage.

Action	on Front Panel	on Keyboard
To move the pointer,	use \leftarrow , \rightarrow , \uparrow , or \downarrow of MARKER/CURSOR area.	use \leftarrow , \rightarrow , \uparrow , or \downarrow .
To move the cursor to edit in display area,	use \leftarrow or \rightarrow of Edit area.	use Backspace key.
To enter "SQID" in NAME field,	press $S(+)$, $Q(2)$, $I(*)?$, $D(/)$, then Enter .	type SQID, then press Enter .
To enter "SQRT(ID) ¹ " in DEFINITION field,	press $S(+)$, $Q(2)$, $R(3)$, $T(p)\%$, \square (blue key), $A(\square)$, ID , $B(\square)$, then Enter .	type SQRT(ID), then press Enter .
To enter "DSQID" in NAME field,	press $D(/)$, $S(+)$, $Q(2)$, $I(*)?$, $D(/)$, then Enter .	type DSQID, then press Enter .
To enter "DIFF(SQID, VG) ² " in DEFINITION field,	press $D(/)$, $I(*)?$, $F(7)$, $\{$, $F(7)$, $\{$, \square (blue key), $A(\square)$, \square (blue key), $S(+)$, $Q(2)$, $I(*)?$, $D(/)$, \square (blue key), $X(\square)$, $>$, VG , $B(\square)$, then Enter .	type DIFF(SQID, VG), then press Enter .
To disable a user function,	select DISABLE FUNCTION secondary softkey.	press Shift - F7 key.

1 Square root operator $\sqrt{\quad}$ is defined by "SQRT" built-in function.

2 Partial difference $\frac{\partial}{\partial}$ is defined by "DIFF" built-in function.

Step 5. Set up the measurement parameters

You set the output parameters on the MEASURE: SWEEP SETUP page.

1. Press **Meas** front-panel key. The MEASURE: SWEEP SETUP page appears.

MEASURE: SWEEP SETUP page

*VARIABLE	VAR1	VAR2
UNIT	SMU3:MP	
NAME	VD	
SWEEP MODE	SINGLE	
LIN LOG	LINEAR	
START	0.0000 V	
STOP	1.0000 V	
SETP	10.00 mV	
NO OF STEP	101	
COMPLIANCE	100.00mA	
POWER COMP	OFF	

UNIT	VAR1'
SMU2:MP	
VG	
OFFSET	0.0000 V
RATIO	1.000
COMPLIANCE	100.00mA
POWER COMP	OFF

2. Set the VAR1 information as follows:

*VARIABLE	VAR1	VAR2
UNIT	SMU3:MP	
NAME	VD	
SWEEP MODE	SINGLE	
LIN LOG	LINEAR	
START	0.0000 V	
STOP	2.0000 V	
SETP	10.00 mV	
NO OF STEP	101	
COMPLIANCE	100.00mA	
POWER COMP	OFF	

Drain voltage sweeps from 0 V to 2 V with 10 mV step. The current compliance is set to 100 mA.

Action	on Front Panel	on Keyboard
To move the pointer,	use \leftarrow , \rightarrow , \uparrow , or \downarrow .	use \leftarrow , \rightarrow , \uparrow , or \downarrow .
To set "SINGLE" in SWEEP MODE field,	select SINGLE secondary softkey.	press Shift - F1 keys.
To set "LINEAR" in LIN/LOG field,	select LINEAR secondary softkey.	press Shift - F1 keys.
To enter "2.000 V" in STOP field,	press Q 2 , then Enter .	type 2, then press Enter .
To enter "10.00 mV" in STEP field,	press P 1 $\text{\$}$, U 0 \# , E m \@ , then Enter .	type 10m, then press Enter .

3. Set the VAR1' information as follows:

	VAR1'
UNIT	SMU2:MP
NAME	VG
OFFSET	0.0000 V
RATIO	1.000
COMPLIANCE	100.00mA
POWER COMP	OFF

To force the same voltage to the drain and gate, set $RATIO = 1$ and $OFFSET = 0$. Because VAR1' is defined as follows:

$$(VAR1' \text{ output}) = RATIO \times (VAR1 \text{ output}) + OFFSET$$

Action	on Front Panel	on Keyboard
To enter "0.000 V" in OFFSET field,	press U 0 \# , then Enter .	type 0, then press Enter .
To enter "1.000" in RATIO field,	press P 1 $\text{\$}$, then Enter .	type 1, then press Enter .

Step 6. Set up the results display

You set the results display information on the DISPLAY: DISPLAY SETUP page.

1. Press **Display** front-panel key. The DISPLAY: DISPLAY SETUP page appears.

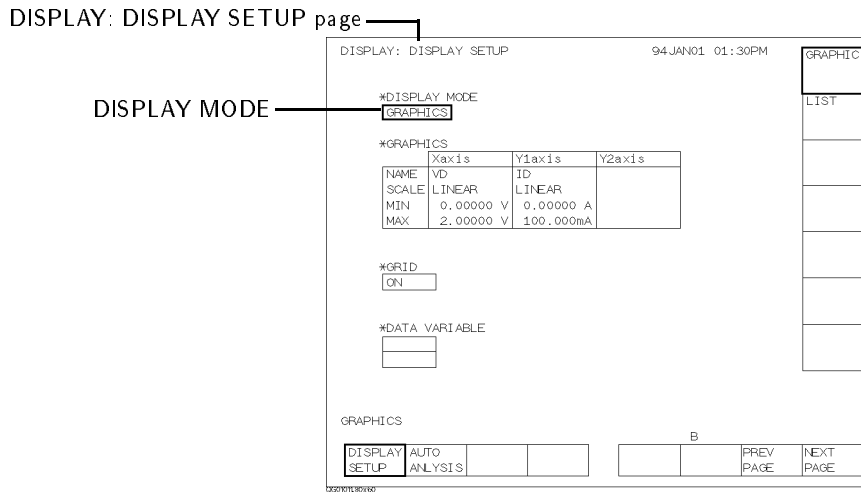

2. Make sure **GRAPHICS** is displayed in the DISPLAY MODE field. If not, select **GRAPHIC** secondary softkey in the DISPLAY MODE field.
3. Set the X-, Y1-, and Y2-axes information as follows:

*GRAPHICS

	Xaxis	Y1axis	Y2axis
NAME	VG	SQID	DSQID
SCALE	LINEAR	LINEAR	LINEAR
MIN	0.00000 V	0.00000 A	0.00000 A
MAX	2.00000 V	100.000mA	100.000mA

0001012.80x26

Action	on Front Panel	on Keyboard
To enter "VG" in NAME field,	select VG secondary softkey.	press (Shift)(F3) keys.
To set "LINEAR" in SCALE field,	select LINEAR secondary softkey.	press (Shift)(F1) keys.
To enter "0.00000 V" in MIN field,	press U(0)# , then (Enter) .	type 0, then press (Enter) .
To enter "2.00000 V" in MAX field,	press Q(2) , then (Enter) .	type 2, then press (Enter) .
To enter "SQID" in NAME field,	select MORE 1/2 , then SQID secondary softkeys.	press (Shift)(F7) keys, then (Shift)(F3) keys.
To enter "0.00000 A" in MIN field,	press U(0)# , then (Enter) .	type 0, then press (Enter) .
To enter "100.000mA" in MAX field,	press P(1)\$, U(0)# , U(0)# , E(m)® , then (Enter) .	type 100m, then press (Enter) .
To enter "DSQID" in NAME field,	select MORE 1/2 , then DSQID secondary softkeys.	press (Shift)(F7) keys, then (Shift)(F4) keys.

Step 7. Execute the measurement

- Press **[Single]** front-panel key to execute the measurement.

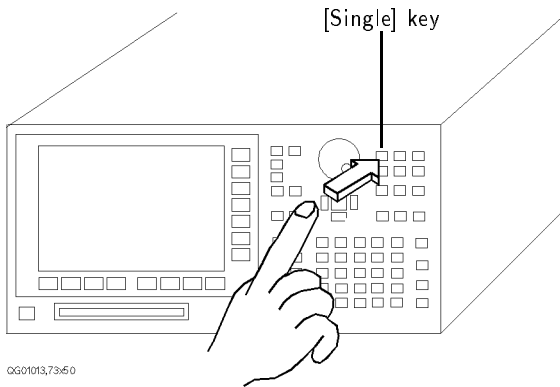

You should get measurement results similar to the following figure.

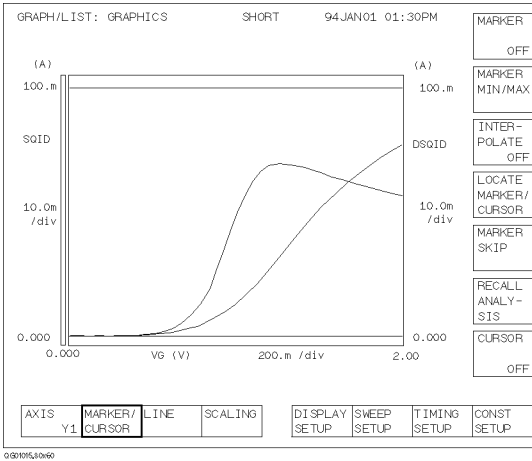

Analyzing the Results

In the previous section, you measured the drain current (I_d) while performing a synchronous sweep of the gate voltage (V_g) and drain voltage (V_d). And the measurement results were drawn graphically on the screen.

In this section, you analyze the measurement results on the graph and search threshold voltage (V_{th}) of the DUT.

The basic algorithm to search for the threshold voltage is:

1. Assign gate voltage (V_g) to X-axis, $\sqrt{I_d}$ to Y1-axis, and $\frac{\partial}{\partial V_g}\sqrt{I_d}$ to Y2-axis.
2. Search for the maximum value of $\frac{\partial}{\partial V_g}\sqrt{I_d}$ curve, which is also the point where the gradient of $\sqrt{I_d}$ curve is maximum.
3. Draw a tangent line to the point where the gradient of $\sqrt{I_d}$ curve is maximum.
4. Read the X-coordinate value where the tangent line crosses the X-axis. This value is threshold value (V_{th}).

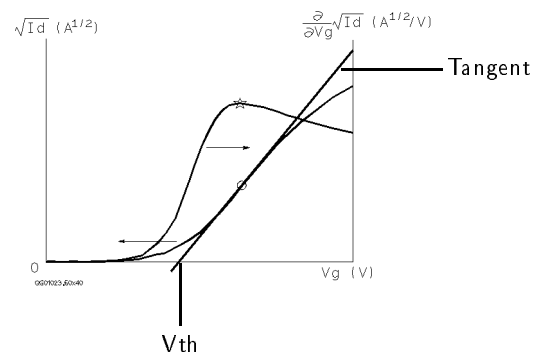

Find the threshold voltage

1. Make sure that **MARKER/CURSOR** primary softkey is highlighted. If not, select the **MARKER/CURSOR** primary softkey.

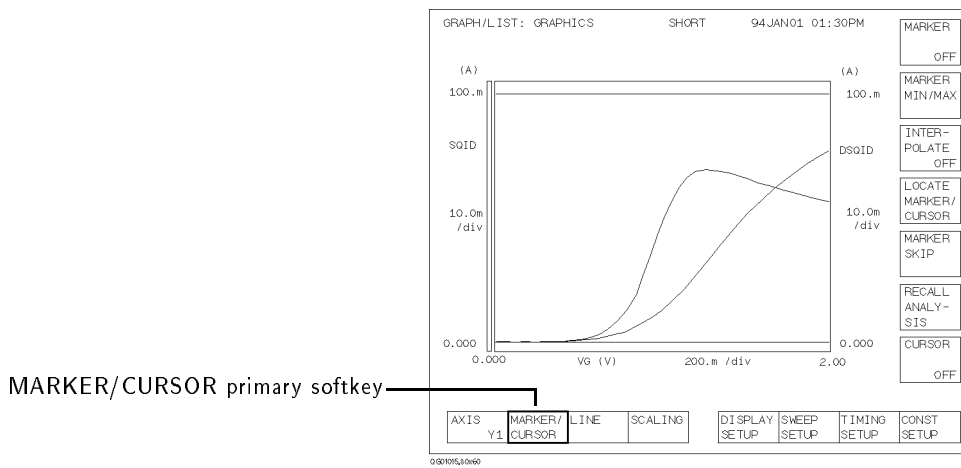

2. Select **MARKER** secondary softkey so that **ON** appears on the softkey. The **MARKER** softkey is highlighted, and the markers appears on the measurement curve.

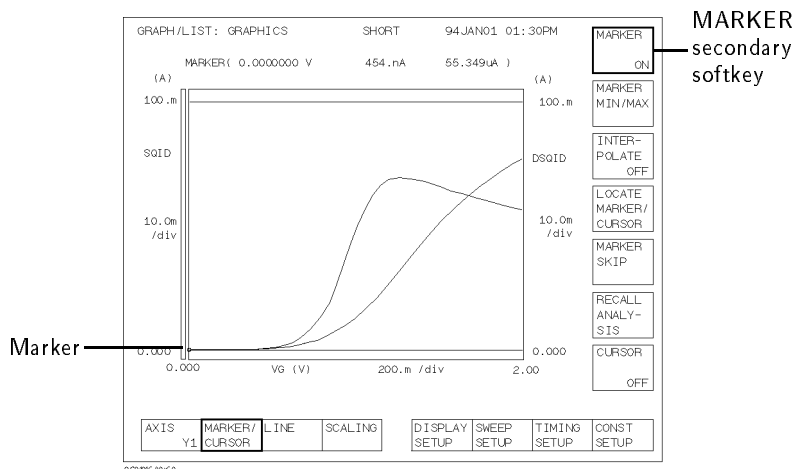

3. Select **AXIS** primary softkey so that **Y2** appears on the softkey. The **Y2** axis is highlighted.

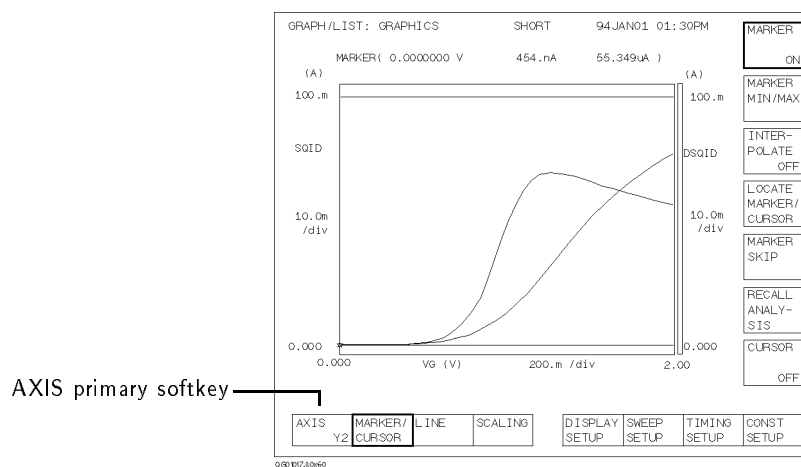

Getting Started
Analyzing the Results

4. Select **MARKER MIN/MAX** secondary softkey until the * marker moves to the maximum point on the Y2 curve. The o marker (on Y1 curve) also moves to same X-axis point, which is maximum gradient of Y1 curve.

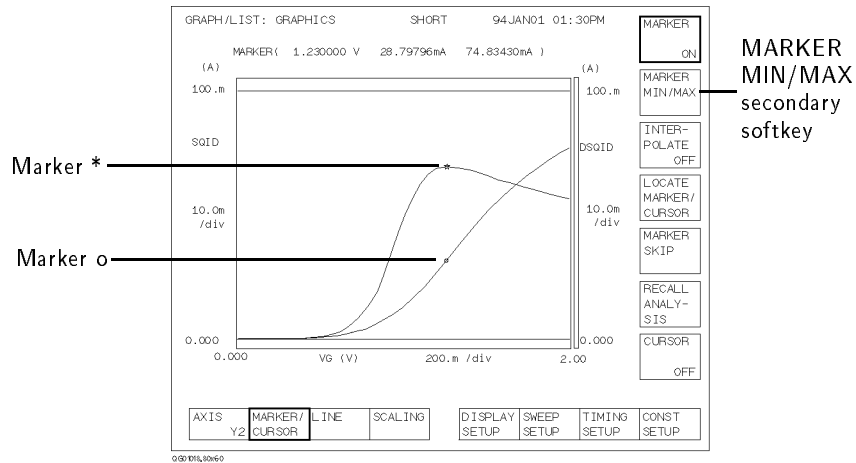

5. Select **AXIS** primary softkey so that Y1 appears on the softkey. The Y1 axis is highlighted.

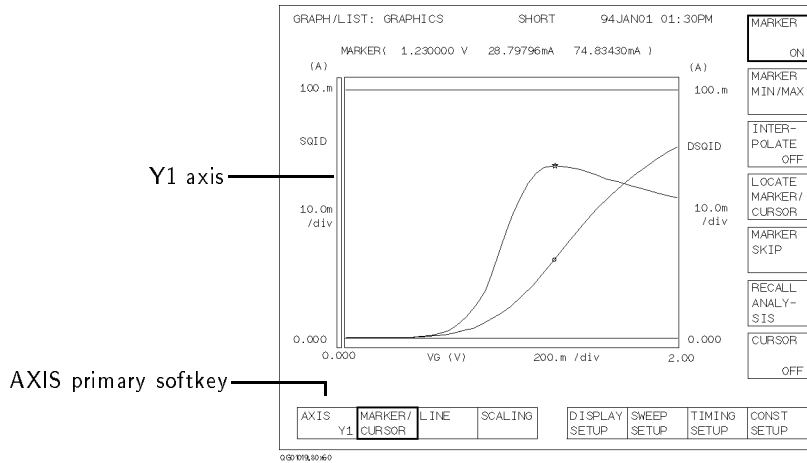

6. Select **LINE** primary softkey. The secondary softkey menu changes.

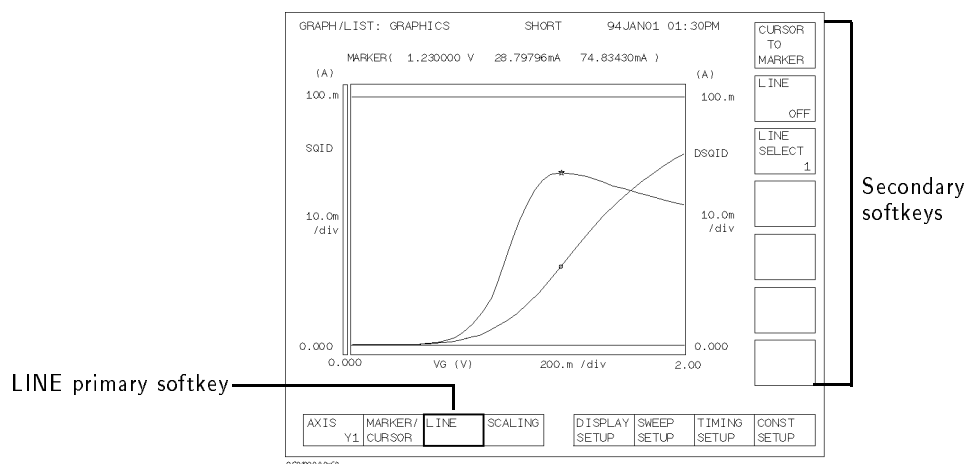

7. Select **LINE** secondary softkey so that **ON** appears on the softkey. The **LINE** softkey is highlighted, and a vertical line appears in the center of the plotting area.

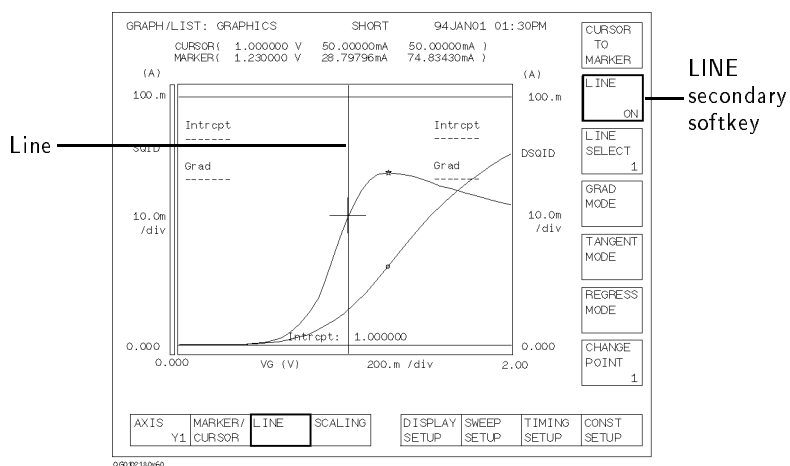

Getting Started
Analyzing the Results

8. Select **TANGENT MODE** secondary softkey. The line becomes tangent to the \circ marker of the Y1 curve.

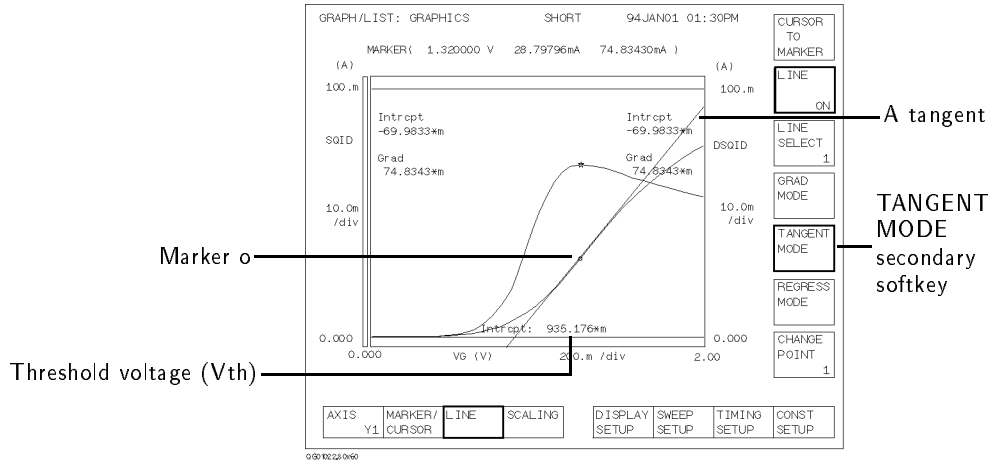

Read the X-axis intercept value of the tangent line. This is the threshold voltage (V_{th}). In the example above, V_{th} is 935 mV.

If You Have a Problem

This section describes how to solve the following unexpected problems:

- If HP 4155A/4156A cannot be powered on
- If display page does not appear after applying power
- If HP 16442A test fixture is not stable

If HP 4155A/4156A cannot be powered on

- Check that the power cable is firmly connected to HP 4155A/4156A and to power outlet.
- Check that the front-panel LINE switch is on.
- Check that the voltage selector switch is set properly.

The voltage selector switch is located in the lower-right corner of the rear panel. The following table shows the line voltage selector setting.

Line Voltage	Position
84-124 Vac	left
200-248 Vac	right

- Check that the fuse is good.

The fuse holders located in the lower-right corner of the rear panel.

1. Turn the HP 4155A/4156A off and disconnect the power cable from the power outlet.
2. Unscrew the fuse holder on the rear panel.
3. Inspect that the correct fuse is installed, and wire inside the fuse is *not* broken by using a tester.

Line	Fuse Type	HP Part Number
110/120 Vac	Time-delay type 8A, 250 Vac	2110-0383
220/240 Vac	Time-delay type 4A, 250 Vac	2110-0014

4. Replace the fuse, if necessary. Then, screw in the fuse holder.
5. Turn the HP 4155A/4156A on.

If display page does not appear after applying power

- If HP 41501 is installed, *first* turn on the HP 41501, *then* turn on HP 4155A/4156A.
- If the self-test fails, see “If You Have a Problem” in the *HP 4155A/4156A User’s Task Guide*.

If HP 16442A test fixture is not stable

- Install stabilizers on the HP 16442A.
For this procedure, see “Installation” in the *HP 4155A/4156A User’s Task Guide*.
- If you use the HP 16442A test fixture with HP 16440A selector or HP 16441A R-BOX, attach HP 16442A to HP 16440A or HP 16441A by using plates and screws.
For this procedure, see “Installation” in the *HP 4155A/4156A User’s Task Guide*.

Getting Started
If You Have a Problem
