

SCPI Command Reference

**Agilent 4155C Semiconductor Parameter Analyzer
Agilent 4156C Precision Semiconductor Parameter Analyzer**

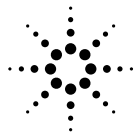

Agilent Technologies

Agilent Part No. 04156-90060

Printed in Japan January 2001

Edition 1

Legal Notice

The information contained in this document is subject to change without notice.

Copyright © 2001 Agilent Technologies

This document contains information which is protected by copyright. All rights are reserved. Reproduction, adaptation, or translation without prior written permission is prohibited, except as allowed under the copyright laws.

- **Product Warranty**

Agilent Technologies warrant Agilent Technologies hardware, accessories and supplies against defects in materials and workmanship for the period of one year from the warranty start date specified below. If Agilent Technologies receive notice of such defects during the warranty period, Agilent Technologies will, at its option, either repair or replace products which prove to be defective. Replacement products may be either new or like-new.

Warranty service of this product will be performed at Agilent Technologies. Buyer shall prepay shipping charges to Agilent Technologies and Agilent Technologies shall pay shipping charges to return the product to Buyer. However, Buyer shall pay all shipping charges, duties, and taxes for products returned to Agilent Technologies from another country.

Agilent Technologies do not warrant that the operation of Agilent Technologies products will be uninterrupted or error free. If Agilent is unable, within a reasonable time, to repair or replace any product to a condition as warranted, customer will be entitled to a refund of the purchase price upon prompt return of the product.

The Agilent Technologies products may contain remanufactured parts equivalent to new in performance or may have been subject to incidental use.

The warranty period begins on the date of delivery or on the date of installation if installed by Agilent Technologies. If customer schedules or delays Agilent Technologies installation more than 30 days after delivery, warranty begins on the 31st day from delivery.

Warranty does not apply to defects resulting from (a) improper or inadequate maintenance or calibration, (b) software, interfacing, parts or supplies not supplied by Agilent Technologies, (c) unauthorized modification or misuse, (d) operation outside of the published environmental specifications for the product, or (e) improper site preparation or maintenance.

To the extent allowed by local law, the above warranties are exclusive and no other warranty or condition, whether written or oral, is expressed or implied and Agilent Technologies specifically disclaim any implied warranties or conditions of merchantability, satisfactory quality, and fitness for a particular purpose.

Agilent Technologies will be liable for damage to tangible property per incident up to the greater of \$300,000 or the actual amount paid for the product that is the subject of the claim, and for damages for bodily injury or death, to the extent that all such damages are determined by a court of competent jurisdiction to have been directly caused by a defective Agilent Technologies product.

To the extent allowed by local law, the remedies in this warranty statement are customer's sole and exclusive remedies. Except as indicated above, in no event will Agilent Technologies or its suppliers be liable for loss of date or for direct, special, incidental, consequential (including lost profit or date), or other damage, whether based in contract, tort, or otherwise.

For consumer transactions in Australia and New Zealand: the warranty terms contained in this statement, except to the extent lawfully permitted, do not exclude, restrict or modify and are in addition to the mandatory statutory rights applicable to the sale of this product to you.

- **Assistance**

Product maintenance agreements and other customer assistance agreements are available for Agilent Technologies products.

For any assistance, contact your nearest Agilent Technologies Sales Office.

- **Certification**

Agilent Technologies Inc. certifies that this product met its published specifications at the time of shipment from the factory. Agilent further certifies that its calibration measurements are traceable to the National Institute of Standards and Technology (NIST), to the extent allowed by the Institute's calibration facility, and to the calibration facilities of other International Standards Organization members.

Printing History

Edition 1: January 2001

Microsoft, Windows, MS-DOS and Excel are registered trademarks of Microsoft Corporation.

NFS is a trademark of Sun Microsystems, Inc.

UNIX is a registered trademark in the United States and other countries, licensed exclusively through X/Open Company Limited.

In This Manual

Agilent 4155C/4156C provides three command modes to control the 4155C/4156C via GPIB interface. You can control the 4155C/4156C using one of the following command modes.

- *4155/4156 SCPI command mode*

SCPI means Standard Commands for Programmable Instruments. This mode is the default mode of the 4155C/4156C, and allows you to control *all* functions of the 4155C/4156C.

- *4155/4156 FLEX command mode*

FLEX means Fast Language for EXecution. This mode allows you to control *measurement* functions of the 4155C/4156C. Command execution is faster than the SCPI command mode.

- *4145 syntax command mode*

This mode allows you to execute the 4145A/B programs on the 4155C/4156C directly with little or no modification. In this command mode, you *cannot* control all functions of the 4155C/4156C.

To confirm the present control mode, see the language mode indicator on the screen, or enter the CMD? command.

Language mode
indicator

The indicator is located between the fourth primary softkey and the fifth primary softkey, and next to the screen lock indicator. The meaning of the indicator is as follows:

S: SCPI command mode

F: FLEX command mode

4: 4145 syntax command mode

CMD? command

This query command returns the present command mode. The response is as follows:

0: SCPI command mode

1: FLEX command mode

2: 4145 syntax command mode

This command is effective for all command mode.

This manual describes about the 4155C/4156C SCPI command set, and consists of the following chapters:

- **Functional Syntax Conventions**
Explains the functional syntax required to create program messages that are transmitted to a 4155C/4156C.
- **Response Message Syntax**
Explains the syntax of the response messages from the 4155C/4156C.
- **Status Reporting Structure**
Explains the status reporting structure of the 4155C/4156C.
- **Common Commands**
Lists SCPI common commands available for the 4155C/4156C, and provides description, command syntax, example statements, and so on.
- **SCPI Commands**
Lists device specific SCPI commands of the 4155C/4156C, and provides description, command syntax, example statements, and so on.
- **Error Messages**
Lists the 4155C/4156C error messages, and provides error number, error message and description.

For information about the 4155C/4156C FLEX command set and the 4145 Syntax command set, refer to *GPIB Command Reference*.

See *User's Guide General Information* and *User's Guide Measurement and Analysis* for information about the 4155C/4156C itself.

Refer to *Programmer's Guide* to make a program and use built-in Instrument BASIC.

Text Conventions

The following text conventions are used in this manual:

- | | |
|---------------|--|
| Screen Text | Represents text that appears on screen of the 4155C/4156C. |
| <i>Italic</i> | Refers to a related document, or is used for emphasis. |

Contents

1. Functional Syntax Conventions

Program Message Syntax	1-3
Subsystem Command Syntax	1-4
Common Command Syntax	1-5
Parameter Types	1-6
(Decimal) Numeric Parameter	1-6
String Parameter	1-8
Character Parameter	1-9
Arbitrary Block Parameter	1-10
Non-decimal Numeric Parameter	1-11
Boolean Parameter	1-12

2. Response Message Syntax

NR1 Numeric Response Data	2-3
NR2 numeric response data	2-4
NR3 Numeric Response Data	2-5
Hexadecimal Numeric Response Data	2-6
Octal Numeric Response Data	2-7
Binary Numeric Response Data	2-8
String Response Data	2-9
Character Response Data	2-10
Definite Length Arbitrary Block Response Data	2-11
Indefinite length arbitrary block response data	2-12

3. Status Reporting Structure

Status Byte Register	3-3
Service Request Enable Register	3-5

Contents

Standard Event Status Register	3-6
Standard Event Status Enable Register	3-8
Output Queue	3-9
Operation Status Register	3-10
Questionable Status Register	3-12
Emergency Status Register	3-14
Measurement/Stress Status Register	3-15

4. Common Commands

*CAL?	4-3
*CLS	4-4
*ESE	4-5
*ESR?	4-7
*IDN?	4-8
*OPC	4-9
*OPT?	4-10
*PCB	4-11
*RST	4-12
*SRE	4-13
*STB?	4-15
*TRG	4-16
*TST?	4-17
*WAI	4-18

Contents

5. SCPI Commands

CALibration Subsystem	5-4
:CALibration[:ALL]?	5-5
:CALibration:AUTO	5-6
:CALibration:ERRor?	5-7
:CALibration:SElected?	5-8
DATA TRACe Subsystem	5-9
:DATA :TRACe:CATalog?	5-10
:DATA :TRACe[:DATA]	5-11
:DATA :TRACe:DEFine	5-13
:DATA :TRACe:DELeTe:ALL	5-14
:DATA :TRACe:DELeTe[:NAME]	5-14
:DATA :TRACe:FREE?	5-14
:DATA :TRACe:POINts	5-15
:DATA :TRACe:STATus?	5-16
:DATA :TRACe:UNIT	5-17
DIAGnostic Subsystem	5-18
:DIAGnostic:TEST:ABORt	5-19
:DIAGnostic:TEST:CONTInue	5-19
:DIAGnostic:TEST:ERRor?	5-20
:DIAGnostic:TEST[:EXECute]	5-20
:DIAG:TEST:RESult?	5-23
DISPlay Subsystem	5-24
:DISPlay:BRIGHtness	5-25
:DISPlay:CMAP:COLor<n>:HSL	5-26
:DISPlay:CMAP:DEFault	5-27
:DISPlay:CONTrast	5-27
:DISPlay[:WINDow]:ALLocation	5-28
:DISPlay[:WINDow][:STATe]	5-29

Contents

FORMat Subsystem	5-30
:FORMat:BORDER	5-31
:FORMat[:DATA]	5-32
HCOPy Subsystem	5-33
:HCOPy:ABORt	5-36
:HCOPy:DATA?	5-36
:HCOPy:DESTination	5-36
:HCOPy:DEVice:CMOD	5-38
:HCOPy:DEVice:COLor	5-39
:HCOPy:DEVice:LANGuage	5-40
:HCOPy:DEVice:RESolution	5-40
:HCOPy[:IMMEDIATE]	5-41
:HCOPy:INIT	5-41
:HCOPy:ITEM:ALL:DATA?	5-42
:HCOPy:ITEM:ALL[:IMMEDIATE]	5-42
:HCOPy:ITEM:ANNotation:STATe	5-42
:HCOPy:ITEM:ANNotation2:STATe	5-43
:HCOPy:ITEM:FFEed:STATe	5-44
:HCOPy:ITEM:LABEL:STATe	5-44
:HCOPy:ITEM:LABEL:TEXT	5-45
:HCOPy:ITEM:TDSamp:STATe	5-46
:HCOPy:ITEM:PNUMBER:STATe	5-46
:HCOPy:ITEM[:WINDow]:TEXT:STATe	5-47
:HCOPy:ITEM[:WINDow]:TEXT2:STATe	5-48
:HCOPy:ITEM[:WINDow]:TEXT3:STATe	5-48
:HCOPy:ITEM[:WINDow]:TRACe:DATA?	5-49
:HCOPy:ITEM[:WINDow]:TRACe:GRATICule:STATe	5-50
:HCOPy:ITEM[:WINDow]:TRACe[:IMMEDIATE]	5-50
:HCOPy:ITEM[:WINDow]:TRACe:STATe	5-51
:HCOPy:LINDEX	5-52
:HCOPy:OPAGe	5-52

Contents

:HCOPy:PAGE:COLumn	5-53
:HCOPy:PAGE:DIMensions:LLEFt	5-54
:HCOPy:PAGE:DIMensions:QUADrant<n>	5-54
:HCOPy:PAGE:DIMensions:URIGht	5-55
:HCOPy:PAGE:DIMensions:WHOLe	5-55
:HCOPy:PAGE:FDIRection	5-56
:HCOPy:PAGE:LENGth	5-56
:HCOPy:PAGE:LINE	5-57
:HCOPy:PAGE:SIZE	5-58
:HCOPy:PAGE:UNIT	5-58
:HCOPy:PAGE:WIDTh	5-59
:HCOPy:SDUMp:DATA?	5-60
:HCOPy:SDUMp[:IMMediate]	5-60
:HCOPy:TRAIler	5-61
MMEMory Subsystem	5-62
:MMEMory:CATalog?	5-63
:MMEMory:CDIRectory	5-64
:MMEMory:COpy	5-65
:MMEMory:DELeTe	5-66
:MMEMory:DESTination	5-67
:MMEMory:INITialize	5-69
:MMEMory:LOAD:STATe	5-70
:MMEMory:LOAD:TRACe	5-71
:MMEMory:MOVE	5-72
:MMEMory:NAME	5-73
:MMEMory:STORe:SSHeet	5-74
:MMEMory:STORe:SSHeet:DELimiter	5-74
:MMEMory:STORe:SSHeet:LINDex	5-75
:MMEMory:STORe:SSHeet:SMARK	5-76
:MMEMory:STORe:SSHeet:UNIT	5-76
:MMEMory:STORe:STATe	5-77

Contents

:MMEMory:STORe:TRACe	5-78
PAGE Subsystem	5-79
:PAGE:CHAN Commands	5-81
:PAGE:CHANnels[:CDEFinition]:ALL:DISable	5-83
:PAGE:CHANnels[:CDEFinition]:COMMeNt	5-83
:PAGE:CHANnels[:CDEFinition]:DEFault	5-84
:PAGE:CHANnels[:CDEFinition]:GNdu:DISable	5-84
:PAGE:CHANnels[:CDEFinition]:GNdu:MODE?	5-84
:PAGE:CHANnels[:CDEFinition]:GNdu:VNAME	5-85
:PAGE:CHANnels[:CDEFinition][:MENU]	5-85
:PAGE:CHANnels[:CDEFinition]:MODE	5-86
:PAGE:CHANnels[:CDEFinition]:PGU<n>:DISable	5-86
:PAGE:CHANnels[:CDEFinition]:PGU<n>:MODE	5-86
:PAGE:CHANnels[:CDEFinition]:PGU<n>:STANdbY	5-87
:PAGE:CHANnels[:CDEFinition]:PGU<n>:VNAME	5-88
:PAGE:CHANnels[:CDEFinition]:SMU<n>:DISable	5-88
:PAGE:CHANnels[:CDEFinition]:SMU<n>:FUNcTION	5-89
:PAGE:CHANnels[:CDEFinition]:SMU<n>:INAME	5-90
:PAGE:CHANnels[:CDEFinition]:SMU<n>:MODE	5-91
:PAGE:CHANnels[:CDEFinition]:SMU<n>:SRESistance	5-92
:PAGE:CHANnels[:CDEFinition]:SMU<n>:STANdbY	5-92
:PAGE:CHANnels[:CDEFinition]:SMU<n>:VNAME	5-93
:PAGE:CHANnels[:CDEFinition]:VMU<n>:DCHarge	5-94
:PAGE:CHANnels[:CDEFinition]:VMU<n>:DISable	5-95
:PAGE:CHANnels[:CDEFinition]:VMU<n>:MODE	5-95
:PAGE:CHANnels[:CDEFinition]:VMU<n>:VNAME	5-96
:PAGE:CHANnels[:CDEFinition]:VSU<n>:DISable	5-96
:PAGE:CHANnels[:CDEFinition]:VSU<n>:FUNcTION	5-97
:PAGE:CHANnels[:CDEFinition]:VSU<n>:MODE?	5-98
:PAGE:CHANnels[:CDEFinition]:VSU<n>:STANdbY	5-98
:PAGE:CHANnels[:CDEFinition]:VSU<n>:VNAME	5-99

Contents

:PAGE:CHANnels:MATrix:CONNectioN	5-99
:PAGE:CHANnels:MATrix:CONTRoL	5-100
:PAGE:CHANnels:MATrix:GPIB:ADDReSS	5-101
:PAGE:CHANnels:UFUNctioN:CATalog?	5-101
:PAGE:CHANnels:UFUNctioN:DEFine	5-102
:PAGE:CHANnels:UFUNctioN:DELete:ALL	5-103
:PAGE:CHANnels:UFUNctioN:DELete[:NAME]	5-103
:PAGE:CHANnels:UFUNctioN[:MENU]	5-104
:PAGE:CHANnels:UVARiablE:CATalog?	5-104
:PAGE:CHANnels:UVARiablE:DEFine	5-105
:PAGE:CHANnels:UVARiablE:DELete:ALL	5-106
:PAGE:CHANnels:UVARiablE:DELete[:NAME]	5-106
:PAGE:CHANnels:UVARiablE[:MENU]	5-106
:PAGE:DISP Commands	5-107
:PAGE:DISPlay:ANALySis:INTerpolate	5-110
:PAGE:DISPlay:ANALySis:LINE(1 2):ASElect	5-110
:PAGE:DISPlay:ANALySis:LINE(1 2):GRADient	5-111
:PAGE:DISPlay:ANALySis:LINE(1 2):MODE	5-112
:PAGE:DISPlay:ANALySis:LINE(1 2):POINt(1 2) :AFter	5-112
:PAGE:DISPlay:ANALySis:LINE(1 2):POINt(1 2) :AFter:STATe	5-113
:PAGE:DISPlay:ANALySis:LINE(1 2):POINt(1 2):MODE	5-114
:PAGE:DISPlay:ANALySis:LINE(1 2):POINt(1 2) :POSitioN	5-114
:PAGE:DISPlay:ANALySis:LINE(1 2):POINt(1 2):X	5-115
:PAGE:DISPlay:ANALySis:LINE(1 2):POINt(1 2):Y	5-116
:PAGE:DISPlay:ANALySis:LINE(1 2):TANGent:AFter	5-116
:PAGE:DISPlay:ANALySis:LINE(1 2):TANGent:AFter :STATe	5-117
:PAGE:DISPlay:ANALySis:LINE(1 2):TANGent :POSitioN	5-118
:PAGE:DISPlay:ANALySis:MARKer:AFter	5-118
:PAGE:DISPlay:ANALySis:MARKer:AFter:STATe	5-119
:PAGE:DISPlay:ANALySis:MARKer:DISablE	5-120
:PAGE:DISPlay:ANALySis:MARKer:POSitioN	5-120

Contents

:PAGE:DISPlay:ANALysis[:MENU]	5-121
:PAGE:DISPlay[:SETup]:DRESOL	5-121
:PAGE:DISPlay[:SETup]:DVARiables:DELeTe:ALL	5-122
:PAGE:DISPlay[:SETup]:DVARiables:DELeTe[:NAME]	5-122
:PAGE:DISPlay[:SETup]:DVARiables[:SELeCt]	5-123
:PAGE:DISPlay[:SETup]:GRAPhics:GRID	5-124
:PAGE:DISPlay[:SETup]:GRAPhics:LPAram	5-124
:PAGE:DISPlay[:SETup]:GRAPhics:X :Y1 :Y2:DELeTe	5-125
:PAGE:DISPlay[:SETup]:GRAPhics:X :Y1 :Y2:MAX	5-125
:PAGE:DISPlay[:SETup]:GRAPhics:X :Y1 :Y2:MIN	5-126
:PAGE:DISPlay[:SETup]:GRAPhics:X :Y1 :Y2:NAME	5-127
:PAGE:DISPlay[:SETup]:GRAPhics:X :Y1 :Y2:SCALE	5-127
:PAGE:DISPlay[:SETup]:LIST:DELeTe:ALL	5-128
:PAGE:DISPlay[:SETup]:LIST:DELeTe[:NAME]	5-128
:PAGE:DISPlay[:SETup]:LIST[:SELeCt]	5-129
:PAGE:DISPlay[:SETup][:MENU]	5-129
:PAGE:DISPlay[:SETup]:MODE	5-130
:PAGE:GLIS Commands	5-131
:PAGE:GLISt[:GRAPhics]:AANalysis	5-133
:PAGE:GLISt[:GRAPhics]:ASELeCt	5-133
:PAGE:GLISt[:GRAPhics]:CURSOR:DIRect:X :Y1 :Y2	5-133
:PAGE:GLISt[:GRAPhics]:CURSOR[:STATe]	5-134
:PAGE:GLISt[:GRAPhics]:DISPlay:DVARiables	5-135
:PAGE:GLISt[:GRAPhics]:DISPlay:OVERlay:STOVERlay	5-135
:PAGE:GLISt[:GRAPhics]:DISPlay:OVERlay[:PLANE]	5-136
:PAGE:GLISt[:GRAPhics]:DISPlay:OVERlay:SINFO	5-136
:PAGE:GLISt[:GRAPhics]:DISPlay:GRID	5-137
:PAGE:GLISt[:GRAPhics]:DISPlay:LPAram	5-137
:PAGE:GLISt[:GRAPhics]:INTerpolate	5-138
:PAGE:GLISt[:GRAPhics]:LINE:CTMarker	5-138
:PAGE:GLISt[:GRAPhics]:LINE:GRADient	5-139

Contents

:PAGE:GLIST[:GRAPhics]:LINE:LSElect	5-139
:PAGE:GLIST[:GRAPhics]:LINE:MODE	5-140
:PAGE:GLIST[:GRAPhics]:LINE:SCURsor	5-140
:PAGE:GLIST[:GRAPhics]:LINE[:STATE]	5-141
:PAGE:GLIST[:GRAPhics]:MARKer:DIRect:X :Y1 :Y2	5-141
:PAGE:GLIST[:GRAPhics]:MARKer:LIMit	5-142
:PAGE:GLIST[:GRAPhics]:MARKer:SKIP	5-142
:PAGE:GLIST[:GRAPhics]:MARKer[:STATE]	5-143
:PAGE:GLIST[:GRAPhics][:MENU]	5-143
:PAGE:GLIST[:GRAPhics]:SCALing:AUTO	5-143
:PAGE:GLIST[:GRAPhics]:SCALing:CANCel	5-144
:PAGE:GLIST[:GRAPhics]:SCALing:CENTer	5-144
:PAGE:GLIST[:GRAPhics]:SCALing:CTMarker	5-144
:PAGE:GLIST[:GRAPhics]:SCALing:ZOOM	5-145
:PAGE:GLIST:LIST:ASElect	5-145
:PAGE:GLIST:LIST:MARKer:DIRect	5-146
:PAGE:GLIST:LIST:MARKer:SKIP	5-147
:PAGE:GLIST:LIST:MARKer[:STATE]	5-147
:PAGE:GLIST:LIST[:MENU]	5-147
:PAGE:KSW Commands	5-148
:PAGE:KSWeep:CURSor:X	5-149
:PAGE:KSWeep:CURSor:Y	5-149
:PAGE:KSWeep:DISPlay:DIRect:ion:X	5-150
:PAGE:KSWeep:DISPlay:DIRect:ion:Y	5-151
:PAGE:KSWeep:DISPlay:GRID	5-151
:PAGE:KSWeep:DISPlay:REGion:X	5-152
:PAGE:KSWeep:DISPlay:REGion:Y	5-152
:PAGE:KSWeep[:MENU]	5-153
:PAGE:KSWeep:SCOpY	5-153
:PAGE:KSWeep:VAR1:EXTent	5-153
:PAGE:KSWeep:VAR1:MODE	5-154

Contents

:PAGE:KSWeep:VAR1:POINts	5-155
:PAGE:KSWeep:VAR1:POLarity	5-156
:PAGE:KSWeep:VAR1:RANGe	5-156
:PAGE:KSWeep:VAR1:STIME	5-157
:PAGE:KSWeep:Y	5-158
:PAGE:MEAS Commands	5-159
:PAGE:MEASure:MSETup:ITIME:LONG:APERture?	5-165
:PAGE:MEASure:MSETup:ITIME:LONG[:NPLCycle]	5-165
:PAGE:MEASure:MSETup:ITIME:MEDIum:APERture?	5-166
:PAGE:MEASure:MSETup:ITIME:MEDIum:NPLCycles?	5-166
:PAGE:MEASure:MSETup:ITIME[:MODE]	5-167
:PAGE:MEASure:MSETup:ITIME:SHORt[:APERture]	5-168
:PAGE:MEASure:MSETup:ITIME:SHORt:NPLCycles?	5-169
:PAGE:MEASure:MSETup[:MENU]	5-169
:PAGE:MEASure:MSETup:SMU<n>:VMU<n>:RANGe	5-170
:PAGE:MEASure:MSETup:SMU<n>[:VMU<n>]:RANGe:MODE	5-171
:PAGE:MEASure:MSETup:WTIME	5-172
:PAGE:MEASure:MSETup:ZCANcel:SMU<n>[:VMU<n>?]	5-172
:PAGE:MEASure:MSETup:ZCANcel[:STATe]	5-173
:PAGE:MEASure:OSEquence[:MENU]	5-174
:PAGE:MEASure:OSEquence:MODE	5-174
:PAGE:MEASure:OSEquence:OSEquence	5-174
:PAGE:MEASure:OSEquence:TRIGger:FUNCTion	5-175
:PAGE:MEASure:OSEquence:TRIGger:POLarity	5-176
:PAGE:MEASure:OSEquence:TRIGger[:STATe]	5-176
:PAGE:MEASure:OSEquence:TRIGger:TIME	5-177
:PAGE:MEASure:PGUSetup:CONStant:PGU<n>[:SOURce]	5-178
:PAGE:MEASure:PGUSetup[:MENU]	5-178
:PAGE:MEASure:PGUSetup:PULSe:PGU<n>:BASE	5-179
:PAGE:MEASure:PGUSetup:PULSe:PGU<n>:COUNT	5-180
:PAGE:MEASure:PGUSetup:PULSe:PGU<n>:DELay	5-181

Contents

:PAGE:MEASure:PGUSetup:PULSe:PGU<n>:IMPedance	5-182
:PAGE:MEASure:PGUSetup:PULSe:PGU<n>:LEADing	5-183
:PAGE:MEASure:PGUSetup:PULSe:PGU<n>:PEAK	5-184
:PAGE:MEASure:PGUSetup:PULSe:PGU<n>:PERiod	5-185
:PAGE:MEASure:PGUSetup:PULSe:PGU<n>:TRAILing	5-186
:PAGE:MEASure:PGUSetup:PULSe:PGU<n>:WIDTh	5-187
:PAGE:MEASure:QSCV:CINteG	5-188
:PAGE:MEASure:QSCV:CNAME	5-189
:PAGE:MEASure:QSCV:CONStant:SMU<n>:COMPLiance	5-190
:PAGE:MEASure:QSCV:CONStant:SMU<n>[:SOURce]	5-191
:PAGE:MEASure:QSCV:CONStant:VSU<n>[:SOURce]	5-192
:PAGE:MEASure:QSCV:DELay	5-193
:PAGE:MEASure:QSCV:HTIME	5-194
:PAGE:MEASure:QSCV:IINteG	5-195
:PAGE:MEASure:QSCV:LCANcel	5-196
:PAGE:MEASure:QSCV:LNAME	5-197
:PAGE:MEASure:QSCV[:MENU]	5-197
:PAGE:MEASure:QSCV:RANGe	5-198
:PAGE:MEASure:QSCV:SSTop	5-199
:PAGE:MEASure:QSCV:UNIT	5-200
:PAGE:MEASure:QSCV:VAR1:COMPLiance	5-201
:PAGE:MEASure:QSCV:VAR1:CSTEp	5-202
:PAGE:MEASure:QSCV:VAR1:MODE	5-203
:PAGE:MEASure:QSCV:VAR1:START	5-204
:PAGE:MEASure:QSCV:VAR1:STEP	5-205
:PAGE:MEASure:QSCV:VAR1:STOP	5-206
:PAGE:MEASure:QSCV:ZCANcel	5-207
:PAGE:MEASure:SAMPling:CONStant:SMU<n>:COMPLiance	5-208
:PAGE:MEASure:SAMPling:CONStant:SMU<n>[:SOURce]	5-209
:PAGE:MEASure:SAMPling:CONStant:VSU<n>[:SOURce]	5-210
:PAGE:MEASure:SAMPling:FILTer	5-211
:PAGE:MEASure:SAMPling:HTIME	5-211

Contents

:PAGE:MEASure:SAMPling:IINterval	5-212
:PAGE:MEASure:SAMPling[:MENU]	5-212
:PAGE:MEASure:SAMPling:MODE	5-212
:PAGE:MEASure:SAMPling:PERiod	5-213
:PAGE:MEASure:SAMPling:PERiod:AUTO	5-214
:PAGE:MEASure:SAMPling:POINts	5-214
:PAGE:MEASure:SAMPling:SCONdition:ECOunt	5-215
:PAGE:MEASure:SAMPling:SCONdition:EDELay	5-216
:PAGE:MEASure:SAMPling:SCONdition:EVENt	5-216
:PAGE:MEASure:SAMPling:SCONdition:NAME	5-217
:PAGE:MEASure:SAMPling:SCONdition[:STATe]	5-218
:PAGE:MEASure:SAMPling:SCONdition:THReshold	5-218
:PAGE:MEASure[:SWEep]:CONStant:SMU<n>:COMPLiance	5-219
:PAGE:MEASure[:SWEep]:CONStant:SMU<n>[:SOURce]	5-220
:PAGE:MEASure[:SWEep]:CONStant:VSU<n>[:SOURce]	5-221
:PAGE:MEASure[:SWEep]:DELay	5-222
:PAGE:MEASure[:SWEep]:HTIME	5-222
:PAGE:MEASure[:SWEep][:MENU]	5-223
:PAGE:MEASure[:SWEep]:PULSe:BASE	5-223
:PAGE:MEASure[:SWEep]:PULSe:PERiod	5-224
:PAGE:MEASure[:SWEep]:PULSe:WIDTh	5-224
:PAGE:MEASure[:SWEep]:SSTop	5-225
:PAGE:MEASure[:SWEep]:VAR1:COMPLiance	5-226
:PAGE:MEASure[:SWEep]:VAR1:MODE	5-226
:PAGE:MEASure[:SWEep]:VAR1:PCOMpliance	5-227
:PAGE:MEASure[:SWEep]:VAR1:PCOMpliance:STATe	5-228
:PAGE:MEASure[:SWEep]:VAR1:SPACing	5-229
:PAGE:MEASure[:SWEep]:VAR1:STARt	5-230
:PAGE:MEASure[:SWEep]:VAR1:STEP	5-230
:PAGE:MEASure[:SWEep]:VAR1:STOP	5-231
:PAGE:MEASure[:SWEep]:VAR2:COMPLiance	5-232
:PAGE:MEASure[:SWEep]:VAR2:PCOMpliance	5-232

Contents

:PAGE:MEASure[:SWEep]:VAR2:PCOMpliance:STATe	5-233
:PAGE:MEASure[:SWEep]:VAR2:POINts	5-234
:PAGE:MEASure[:SWEep]:VAR2:STARt	5-234
:PAGE:MEASure[:SWEep]:VAR2:STEP	5-235
:PAGE:MEASure[:SWEep]:VARD:COMPLiance	5-236
:PAGE:MEASure[:SWEep]:VARD:OFFSet	5-237
:PAGE:MEASure[:SWEep]:VARD:PCOMpliance	5-238
:PAGE:MEASure[:SWEep]:VARD:PCOMpliance:STATe	5-239
:PAGE:MEASure[:SWEep]:VARD:RATio	5-240
:PAGE:SCON Commands	5-241
:PAGE:SCONtrol:KSWeep[:STARt]	5-242
:PAGE:SCONtrol[:MEASurement]:APPend	5-242
:PAGE:SCONtrol[:MEASurement]:REPeat	5-243
:PAGE:SCONtrol[:MEASurement]:SINGle	5-243
:PAGE:SCONtrol:STANdbY	5-244
:PAGE:SCONtrol:STATe?	5-244
:PAGE:SCONtrol:STOP	5-245
:PAGE:SCONtrol:STRess[:STARt]	5-245
:PAGE:SCONtrol:TRIGger:INPut?	5-245
:PAGE:SCONtrol:TRIGger:OUTPut:LEVel	5-246
:PAGE:SCONtrol:TRIGger:OUTPut[:PULSe]	5-246
:PAGE:SCONtrol:ZERO	5-246
:PAGE:STR Commands	5-247
:PAGE:STRess[:CDEFinition]:ALL:DISable	5-250
:PAGE:STRess[:CDEFinition]:COMMENT	5-250
:PAGE:STRess[:CDEFinition]:GNDU:DISable	5-250
:PAGE:STRess[:CDEFinition]:GNDU:FUNCTion?	5-251
:PAGE:STRess[:CDEFinition]:GNDU:MODE?	5-251
:PAGE:STRess[:CDEFinition]:GNDU:NAME	5-252
:PAGE:STRess[:CDEFinition][:MENU]	5-252
:PAGE:STRess[:CDEFinition]:PGU<n>:DISable	5-253

Contents

:PAGE:STRess[:CDEFinition]:PGU<n>:FUNCTION	5-253
:PAGE:STRess[:CDEFinition]:PGU<n>:MODE	5-254
:PAGE:STRess[:CDEFinition]:PGU<n>:NAME	5-254
:PAGE:STRess[:CDEFinition]:SElectoR<n>:MEASure	5-255
:PAGE:STRess[:CDEFinition]:SElectoR<n>:STRess	5-256
:PAGE:STRess[:CDEFinition]:SMU<n>:DISable	5-256
:PAGE:STRess[:CDEFinition]:SMU<n>:FUNCTION	5-257
:PAGE:STRess[:CDEFinition]:SMU<n>:MODE	5-258
:PAGE:STRess[:CDEFinition]:SMU<n>:NAME	5-259
:PAGE:STRess[:CDEFinition]:TRIGger:POLarity	5-260
:PAGE:STRess[:CDEFinition]:TRIGger[:STATe]	5-260
:PAGE:STRess[:CDEFinition]:VSU<n>:DISable	5-261
:PAGE:STRess[:CDEFinition]:VSU<n>:FUNCTION	5-261
:PAGE:STRess[:CDEFinition]:VSU<n>:MODE?	5-262
:PAGE:STRess[:CDEFinition]:VSU<n>:NAME	5-262
:PAGE:STRess:FORCe:ACCumulate	5-263
:PAGE:STRess:FORCe[:MENU]	5-263
:PAGE:STRess:FORCe:STATus	5-264
:PAGE:STRess:SETup:ACCumulate	5-264
:PAGE:STRess:SETup:CONStant:PGU<n>[:SOURce]	5-265
:PAGE:STRess:SETup:CONStant:SMU<n>:COMpliance	5-266
:PAGE:STRess:SETup:CONStant:SMU<n>[:SOURce]	5-267
:PAGE:STRess:SETup:CONStant:VSU<n>[:SOURce]	5-268
:PAGE:STRess:SETup:DURation	5-268
:PAGE:STRess:SETup:FILTer	5-269
:PAGE:STRess:SETup:HTIME	5-270
:PAGE:STRess:SETup[:MENU]	5-270
:PAGE:STRess:SETup:MODE	5-270
:PAGE:STRess:SETup:PCOunt	5-271
:PAGE:STRess:SETup:PULSe:PGU<n>:BASE	5-272
:PAGE:STRess:SETup:PULSe:PGU<n>:DELay	5-272
:PAGE:STRess:SETup:PULSe:PGU<n>:IMPedance	5-273

Contents

:PAGE:STResS:SETup:PULSe:PGU<n>:LEADing	5-274
:PAGE:STResS:SETup:PULSe:PGU<n>:PEAK	5-275
:PAGE:STResS:SETup:PULSe:PGU<n>:PERiod	5-276
:PAGE:STResS:SETup:PULSe:PGU<n>:TRAILing	5-276
:PAGE:STResS:SETup:PULSe:PGU<n>:WIDTh	5-277
:PAGE:STResS:SETup:SSTop	5-278
:PAGE:SYST Commands	5-279
:PAGE:SYSTem:CDIagnostic[:MENU]	5-280
:PAGE:SYSTem:COLor[:MENU]	5-280
:PAGE:SYSTem:CONFig[:MENU]	5-280
:PAGE:SYSTem:FILer[:MENU]	5-280
:PAGE:SYSTem:MISC[:MENU]	5-281
:PAGE:SYSTem:PRINt[:MENU]	5-281
PROGram Subsystem	5-282
:PROGram:CATalog?	5-284
:PROGram[:SELEcted]:DEFine	5-284
:PROGram[:SELEcted]:DELete[:SELEcted]	5-285
:PROGram[:SELEcted]:DELete:ALL	5-285
:PROGram[:SELEcted]:EXECute	5-285
:PROGram[:SELEcted]:MALLocate	5-286
:PROGram[:SELEcted]:NAME	5-286
:PROG[:SELEcted]:NUMBer	5-286
:PROG[:SELEcted]:STATe	5-287
:PROG[:SELEcted]:STRing	5-288
:PROG[:SELEcted]:WAIT	5-288
STATus Subsystem	5-289
:STATus:EMERgency:ENABle	5-291
:STATus:EMERgency[:EVENT]?	5-291
:STATus:MEASurement:ENABle	5-292
:STATus:MEASurement[:EVENT]?	5-292

Contents

:STATus:OPERation:CONDition?	5-293
:STATus:OPERation:ENABle	5-293
:STATus:OPERation[:EVENT]?	5-294
:STATus:OPERation:NTRansition	5-294
:STATus:OPERation:PTRansition	5-295
:STATus:PRESet	5-295
:STATus:QUEStionable:CONDition?	5-296
:STATus:QUEStionable:ENABle	5-297
:STATus:QUEStionable[:EVENT]?	5-297
:STATus:QUEStionable:NTRansition	5-298
:STATus:QUEStionable:PTRansition	5-299
SYSTem Subsystem	5-300
:SYSTem:BEEPer:STATe	5-302
:SYSTem:COMMunicate:GPIB:RDEvice:ADDReSS	5-302
:SYSTem:COMMunicate:NETwork:FILEr:DELeTe	5-303
:SYSTem:COMMunicate:NETwork:FILEr:NET:DIRectory	5-304
:SYSTem:COMMunicate:NETwork:FILEr:NET:IPADdress	5-305
:SYSTem:COMMunicate:NETwork:FILEr:NET:NAME	5-306
:SYSTem:COMMunicate:NETwork:FILEr:SET	5-307
:SYSTem:COMMunicate:NETwork:PRINter:DELeTe	5-308
:SYSTem:COMMunicate:NETwork:PRINter:NET:GRAPhoption	5-309
:SYSTem:COMMunicate:NETwork:PRINter:NET:IPADdress	5-310
:SYSTem:COMMunicate:NETwork:PRINter:NET:NAME	5-311
:SYSTem:COMMunicate:NETwork:PRINter:NET:TEXToption	5-312
:SYSTem:COMMunicate:NETwork:PRINter:NET:TYPE	5-313
:SYSTem:COMMunicate:NETwork:PRINter:SET	5-314
:SYSTem:COMMunicate:NETwork[:SELF]:GATEway	5-315
:SYSTem:COMMunicate:NETwork[:SELF]:GROUpid	5-316
:SYSTem:COMMunicate:NETwork[:SELF]:IPADdress	5-317
:SYSTem:COMMunicate:NETwork[:SELF]:NAME	5-318
:SYSTem:COMMunicate:NETwork[:SELF]:SNETmask	5-319

Contents

:SYSTem:COMMunicate:NETwork[:SELF]:USERid	5-320
:SYSTem:CONFig:ALL?	5-321
:SYSTem:CONFig:CREVision?	5-322
:SYSTem:CONFig:ETHErnet?	5-322
:SYSTem:CONFig:SLOT?	5-323
:SYSTem:DATE	5-324
:SYSTem:ERRor?	5-324
:SYSTem:LANGUage	5-325
:SYSTem:LFRequency	5-325
:SYSTem:NTMOut	5-326
:SYSTem:SSAVer	5-327
:SYSTem:TIME	5-328
:SYSTem:VERSion?	5-329

6. Error Messages

No Error	6-3
Command Error	6-4
Execution Error	6-8
Device-Dependent Error	6-11
Query Error	6-12

Contents

1 **Functional Syntax Conventions**

Functional Syntax Conventions

Functional syntax is required to create program messages that are transmitted to Agilent 4155C/4156C.

Program Message Syntax

Program messages are composed of sequences of commands.

Figure 1-1

Program Message Syntax

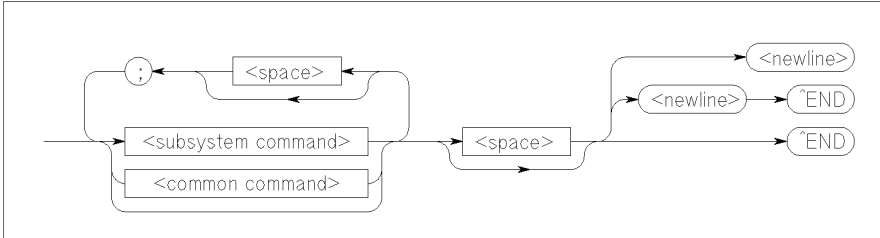

pg04011 120x40

Figure 1-1 shows the syntax of a program message.

You can send multiple commands in the same message by separating them with a semicolon. Refer to the following example:

To terminate a program message, use one of the three program message terminators, which are <newline>, <^END> or <newline><^END>.

<^END> means that EOI is asserted on the GPIB interface at the same time the last data byte is sent.

Subsystem Command Syntax

Figure 1-2 shows the syntax of subsystem commands:

Figure 1-2

Subsystem Command Syntax

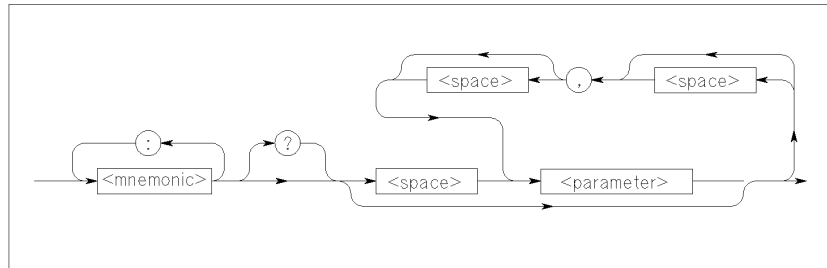

pg040012 120x50

Query requires ? at the end of the command header.

Many command <mnemonic>s have both long and a short form. For example, CHAN is the short form and CHANNELS is the long form of CHANnelS.

Command <mnemonic> is *not* case sensitive, so ChAnNeLs is just as valid as CHANNELS.

Common Command Syntax

Figure 1-3 shows the syntax of common commands:

Figure 1-3

Common Command Syntax

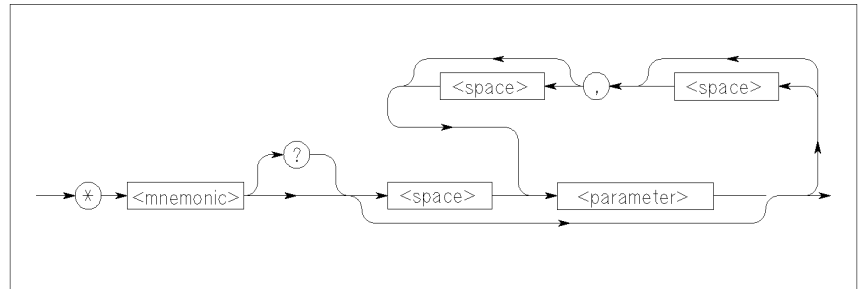

pg04031 120x50

Query requires ? at the end of the command header.

Command <mnemonic> is *not* case sensitive.

Parameter Types

The following data types of command parameters are available:

- (Decimal) Numeric
- String
- Character
- Arbitrary Block
- Non-decimal Numeric
- Boolean

(Decimal) Numeric Parameter

A (decimal) numeric parameter type is decimal data including optional signs, decimal points, and scientific notation defined as follows:

Figure 1-4

(Decimal) Numeric Parameter

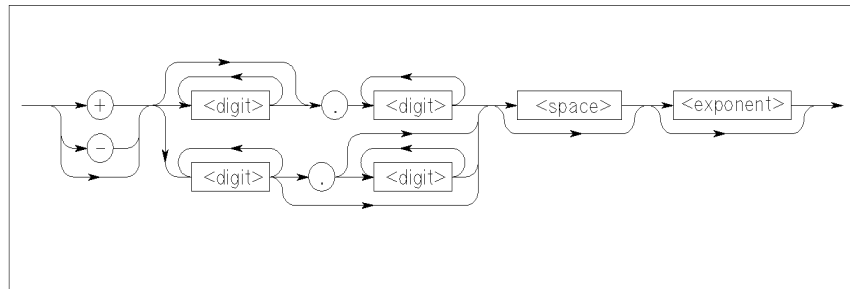

pg040013 120x40

where <exponent> is defined as follows:

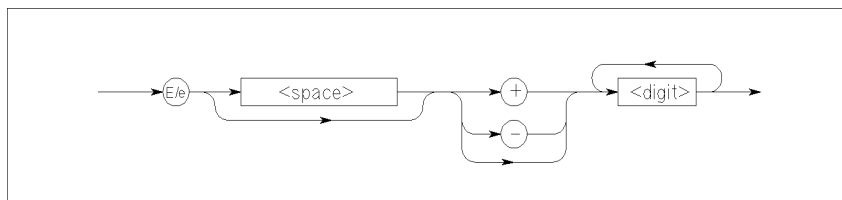

pg040014 120x30

The following shows example numeric parameters that pass the same value:

```
:PAGE:MEAS:CONS:SMU1 123
:PAGE:MEAS:CONS:SMU1 +123.
:PAGE:MEAS:CONS:SMU1 1.23e 100
:PAGE:MEAS:CONS:SMU1 1.23E+100
```

For some numeric parameters, you can use the following character parameters to specify the minimum or maximum allowable value:

MINimum minimum allowable value.

MAXimum maximum allowable value.

For commands that allow MIN or MAX parameter, you can use MIN or MAX to query the minimum or maximum allowable value.

Refer to the following examples:

```
:PAGE:MEAS:CONS:SMU1 MAX specify the maximum allowable value
:PAGE:MEAS:CONS:SMU1? MAX query the maximum allowable value
```

String Parameter

A string parameter type is defined as follows:

Figure 1-5

String Parameter

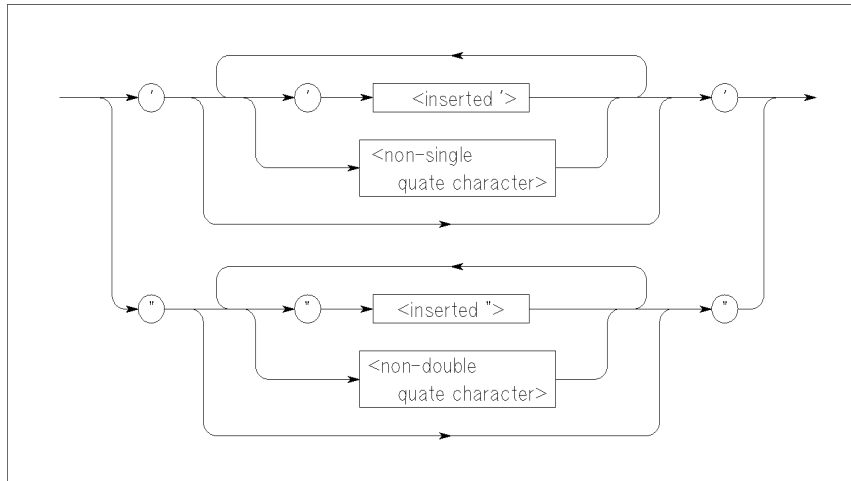

pg040015 120x70

<inserted'> or <inserted"> means when you want to actually use ' or " in the string. For example, for the string don't, you must enter ' don ' t ' .

String parameter is case sensitive.

Refer to the following examples:

```
:PAGE:CHAN:COMM 'This is the example'
```

specifies string: This is the example

```
:PAGE:CHAN:COMM 'This is the ""example""'
```

specifies string: This is the "example"

Character Parameter

A character parameter type is for command parameters that have a specific number of allowed settings. For example, the allowed parameters for :PAGE:CHAN:CDEF:MODE command are *SWEep* and *SAMPling*.

Figure 1-6

Character Parameter

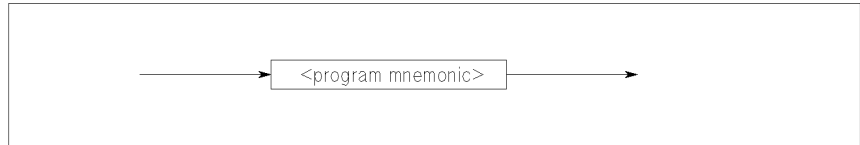

pg040016 120x30

Many <program mnemonic>s have a long form and a short form. For example, you can use *SWE* as short form of *SWEEP*.

<program mnemonic> is *not* case sensitive. For example, the following have the same meaning:

```
:PAGE:CHAN:MODE SWEEP  
:PAGE:CHAN:MODE Sweep
```

Arbitrary Block Parameter

An arbitrary block parameter type is used for binary data transmission and defined as follows:

Figure 1-7

Definite Length Arbitrary Block Parameter

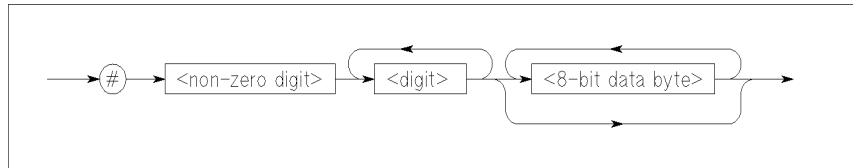

pg04029 120x30

The single decimal digit <non-zero> digit specifies how many <digit>s will follow. The decimal number <digit>s specifies how many <8-bit data byte>s will follow.

Figure 1-8

Indefinite Length Arbitrary Block Parameter

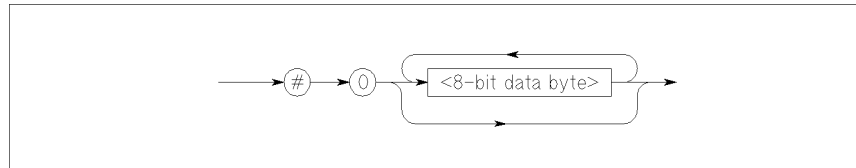

pg04030 120x30

For indefinite length data, use zero 0 digit as shown above.

Non-decimal Numeric Parameter

A non-decimal numeric parameter type allows passing numeric information other than decimal (base 10) numeric data.

There are three types of non-decimal numeric parameters:

Figure 1-9

Non-decimal Numeric Parameter

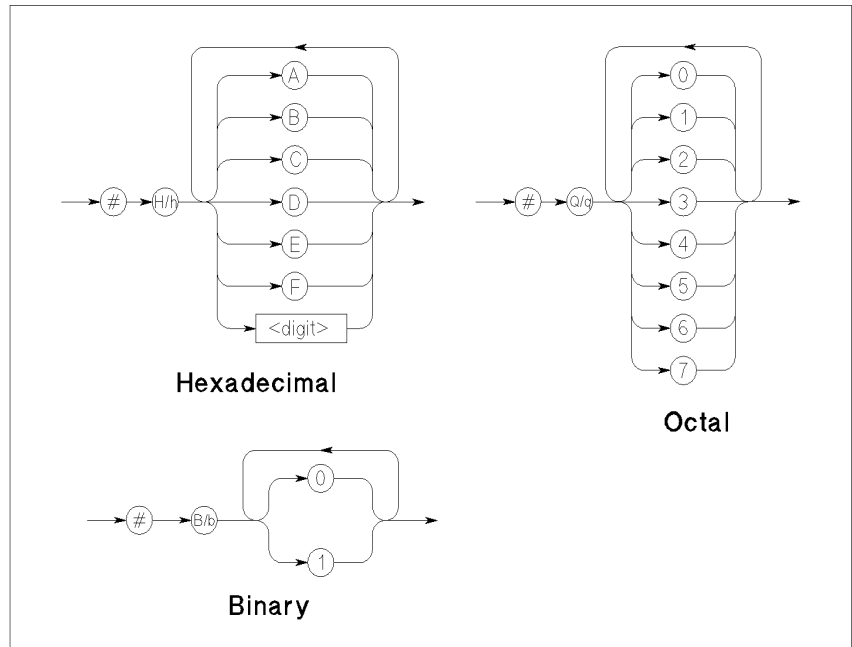

pg040018 12.0x110

Boolean Parameter

A boolean parameter type represents a single binary condition that is either true or false and is defined as follows:

Figure 1-10

Boolean Parameter

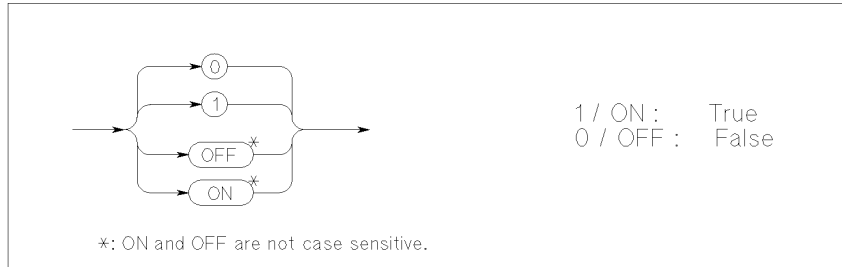

pg04032 120x50

2 **Response Message Syntax**

Response Message Syntax

Figure 2-1 shows the syntax for response messages.

Figure 2-1

Response Message Syntax

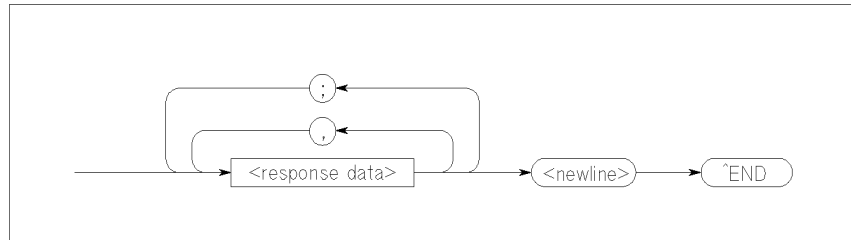

pg040019 120x40

Response messages may contain both commas and semicolons as separators. When a single query command returns multiple values, a comma is used to separate each data item. When multiple queries are sent in the same message, the groups of data items corresponding to each query are separated by a semicolon.

<newline><^END> is always sent as a response message terminator.

A <response data> can be the following data types:

- NR1 numeric response data
- NR2 numeric response data
- NR3 numeric response data
- Hexadecimal numeric response data
- Octal numeric response data
- Binary numeric response data
- String response data
- Character response data
- Definite length arbitrary block response data
- Indefinite length arbitrary block response data

NR1 Numeric Response Data

An NR1 numeric response data is decimal data defined as follows:

Figure 2-2

NR1 Numeric Response Data

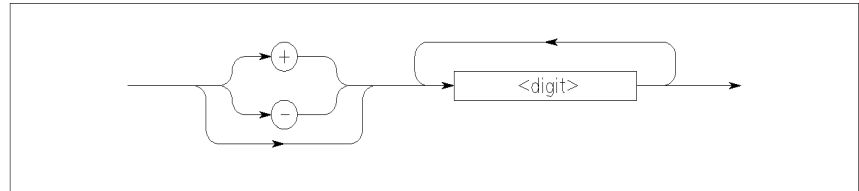

pg040020 120x30

NR2 numeric response data

An NR2 numeric response data is decimal data defined as follows:

Figure 2-3

NR2 Numeric Response Data

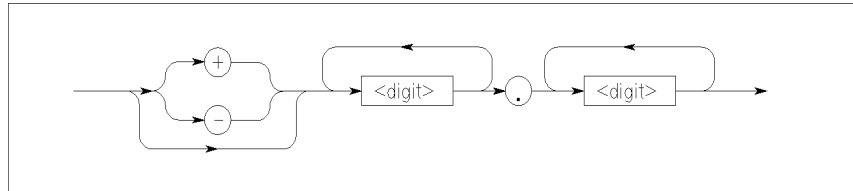

pg040021 120x30

NR3 Numeric Response Data

An NR3 numeric response data is decimal data defined as follows:

Figure 2-4

NR3 numeric response data

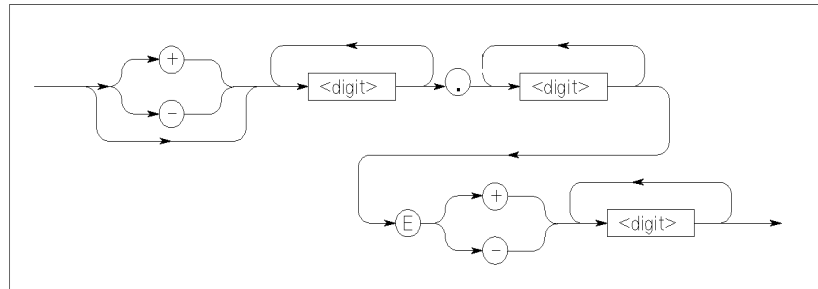

pg040022 120x40

Hexadecimal Numeric Response Data

A hexadecimal numeric response data is defined as follows:

Figure 2-5

Hexadecimal Numeric Response Data

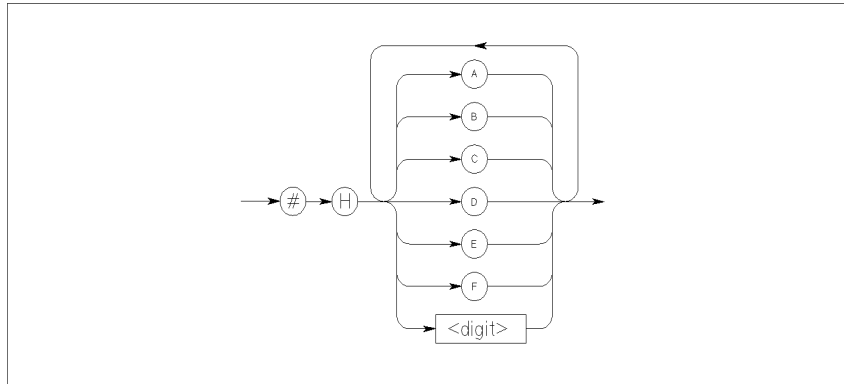

pg040023 120x60

Octal Numeric Response Data

An octal numeric response data is defined as follows:

Figure 2-6

Octal Numeric Response Data

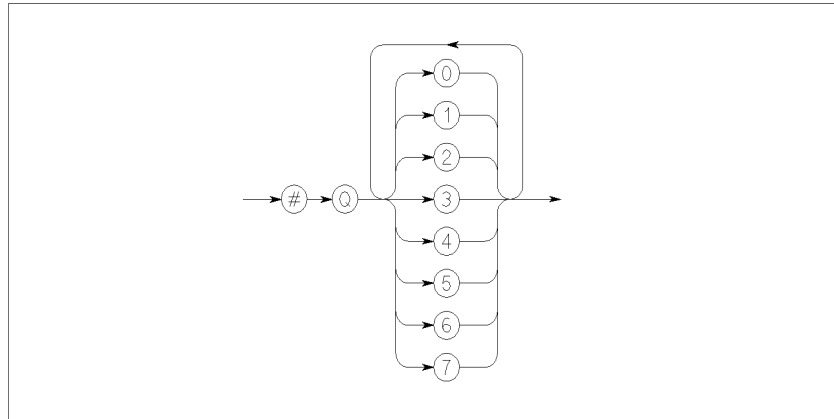

pg04024 120x60

Binary Numeric Response Data

A binary numeric response data is defined as follows:

Figure 2-7

Binary Numeric Response Data

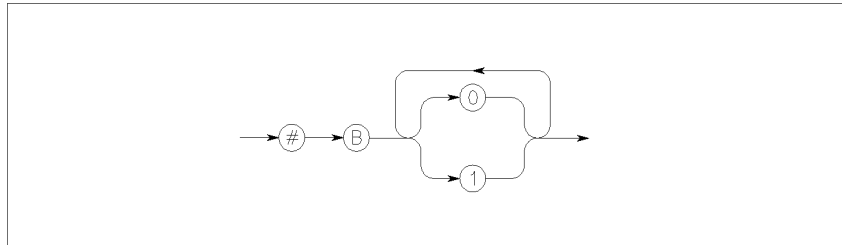

pg04025 120x40

String Response Data

A string response data is defined as follows:

Figure 2-8

String Response Data

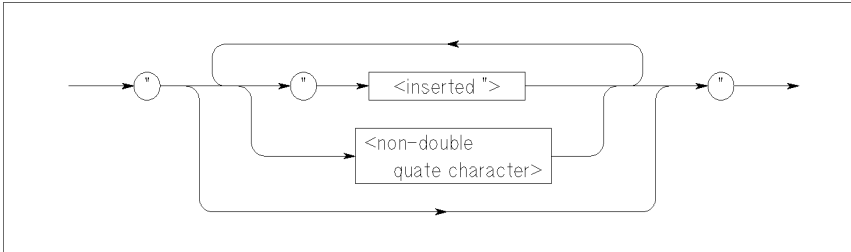

pg04026 120x40

Character Response Data

A character response data is similar to character parameter. The main difference is that character response data returns only the short form of a particular mnemonic, in all uppercase letters.

Figure 2-9

Character Response Data

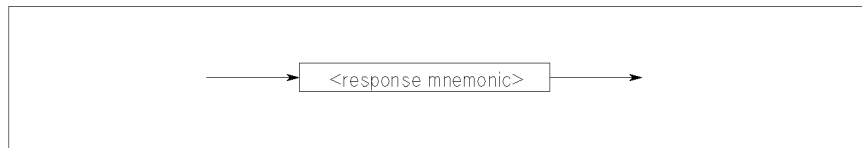

pg04027 120x30

where <response mnemonic> is defined as follows:

Figure 2-10

<response mnemonic>

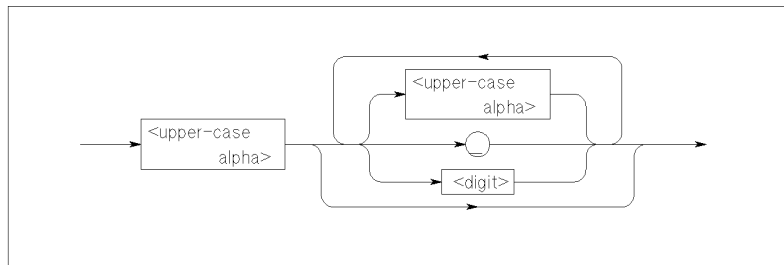

pg04028 120x40

Definite Length Arbitrary Block Response Data

A definite length arbitrary block response data is for a large number of related data and defined as follows:

Figure 2-11

Definite Length Arbitrary Block Response Data

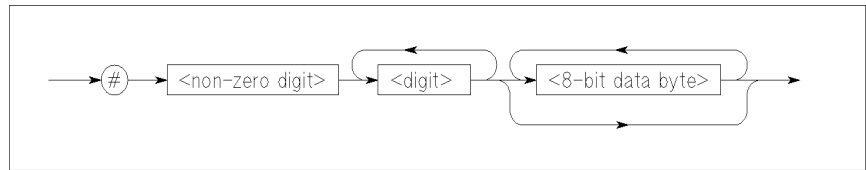

pg04029 120x30

The single decimal digit <non-zero digit> specifies how many <digit>s will follow.
The decimal number <digit>s specifies how many <8-bit data byte>s will follow.

Indefinite length arbitrary block response data

An indefinite length arbitrary block response data is defined as follows:

Figure 2-12

Indefinite Length Arbitrary Block Response Data

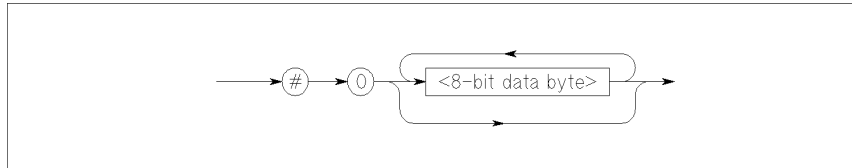

pg04030 120x30

3 **Status Reporting Structure**

Status Reporting Structure

This section describes the status reporting structure used in Agilent 4155C/4156C. These are IEEE488.2 status structures except for the following:

- Standard Operation Status Register (for SCPI)
- Questionable Status Register (for SCPI)
- Emergency Status Register (for 4155C/4156C)
- Measurement Stress/Status Register (for 4155C/4156C)

For more information about these non-IEEE488.2 status structures, see “STATUS Subsystem” in Chapter 5.

In general, the status data structure is used to "request service" or indicate a specific condition (for example, operation complete) via SRQ (Service Request). Note that the user may be notified that certain events have occurred even if the user did not request the information.

Refer to the following figures for a model of the status data structure.

Figure 3-1 Status Reporting Structure

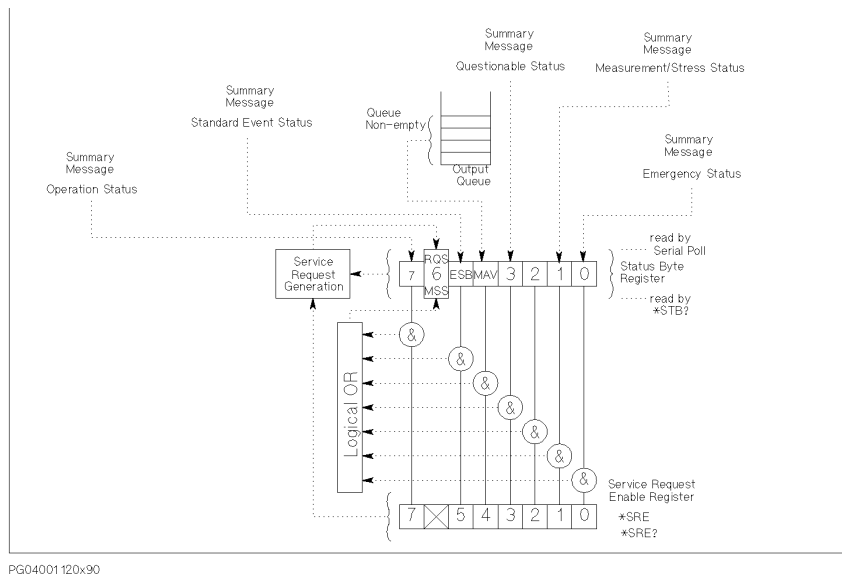

Status Byte Register

The Status Byte register contains bits related to the instrument's Status Byte (STB) summary messages, Request Service (RQS) messages, and Master Summary Status (MSS) messages. Refer to Figure 3-2 and Table 3-1.

Figure 3-2

Status Byte Register

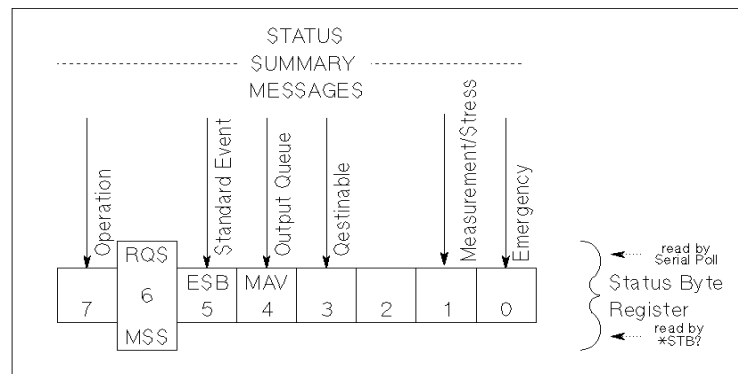

PG04002 100x40

The Status Byte Register can be read with either a serial poll or the *STB? common query command (refer to Chapter 4).

Serial poll is a low-level GPIB command that can be executed by SPOLL in HP BASIC, such as the following:

```
Status=SPOLL (@Hp4155)
```

Both serial poll and STB? read the Status Byte Register identically, but have following difference:

- SPOLL returns RQS for bit6
- STB? returns MSS for bit6

RQS and MSS are always the same value, so returned Status Byte value is always the same for these two methods.

In general, use serial polling (not *STB?) inside interrupt service routines. Use *STB? in other cases (not in interrupt service routine) when you want to know the value of Status Byte.

Status Reporting Structure
 Status Byte Register

Table 3-1

Status Byte Register

Bit	Definition	Explanation
0	Emergency Status Bit Summary Message	Indicates whether one or more of the enabled Emergency Status Register bits is set.
1	Measurement/Stress Status Bit Summary Message	Indicates whether one or more of the enabled Measurement/Stress Status Register bits is set.
2	NOT USED	Always zero.
3	Questionable Status Bit Summary Message	Indicates whether one or more of the enabled Questionable Status Register bits is set.
4	Message Available (MAV) Queue Summary Message	Indicates whether the Output Queue is empty.
5	Standard Event Status Bit (ESB) Summary Message	Indicates whether one or more of the enabled Standard Events Status Register bits is set.
6	Request Service (RQS) Message	Indicates whether a SRQ (Service Request) has occurred.
	Master Summary Status (MSS) Summary Message	Indicates that the instrument has at least one reason for requesting service.
7	Operation Status Bit Summary Message	Indicates whether one or more of the enabled Operation Status Register bits is set.

Service Request Enable Register

The Service Request Enable Register is an 8-bit register that can be used by the programmer to select which summary messages in the Status Byte Register may cause service requests. Refer to Figure 3-3.

Figure 3-3 Service Request Enable Register

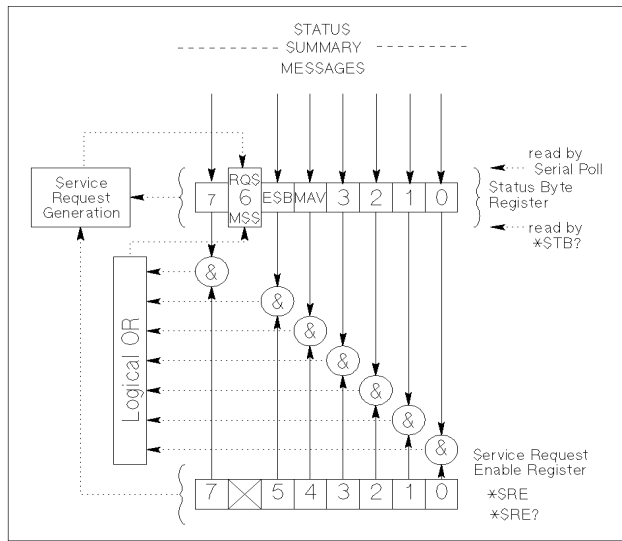

PG04003

Standard Event Status Register

The Standard Event Status Register has specific events assigned to specific bits. Refer to Figure 3-4 and Table 3-2.

Figure 3-4 Standard Event Status Register

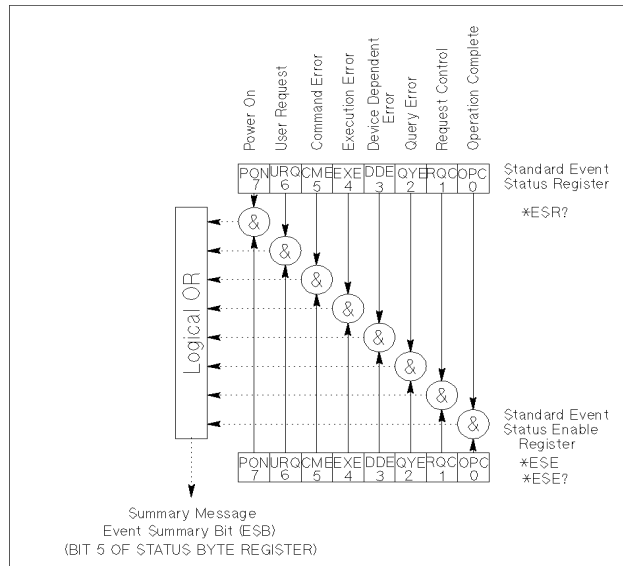

pg04004

Table 3-2 **Standard Event Status Register**

Bit	Definition	Explanation
0	Operation Complete (OPC)	This event bit has meaning only if a request to monitor is set by the *OPC command. Refer to "*OPC" earlier in this chapter. This bit is set to 1 if there are no pending operations.
1	Request Control (RQC)	This event bit indicates to the controller that instrument is requesting permission to become the active controller-in-charge.
2	Query Error (QYE)	<ul style="list-style-type: none"> • An attempt is being made to read data from the Output Queue when no data is present or pending. • Data in the Output Queue has been lost.
3	Device Dependent Error (DDE)	This event bit indicates that an error has occurred which is neither a Command Error, a Query Error, or an Execution Error.
4	Execution Error (EXE)	Syntax of command is correct, but cannot be executed due to some condition of instrument.
5	Command Error (CME)	A command syntax error has been detected.
6	Not Used	Always 0.
7	Power On (PON)	This event bit indicates that an off-to-on transition has occurred in instrument's power supply.
8 to 15	Reserved	Always 0.

Standard Event Status Enable Register

The Standard Event Status "Enable" Register is an 8-bit register that can be used by the program to select which bits of Standard Event Status Register are enabled. The enabled bits are ORed together, and reported to the ESB bit (Bit5) of the Status Byte Register.

The 8 bits of this register correspond to the 8 bits of the Standard Event Status Register. Refer to Figure 3-4.

Output Queue

The Output Queue stores response messages until they are read. If an unread message exists, Bit4 (Message Available - MAV) of the Status Byte Register is set to 1. So, Bit4 is used to synchronize information exchange with the controller. Refer to Figure 3-5.

Figure 3-5

Output Queue

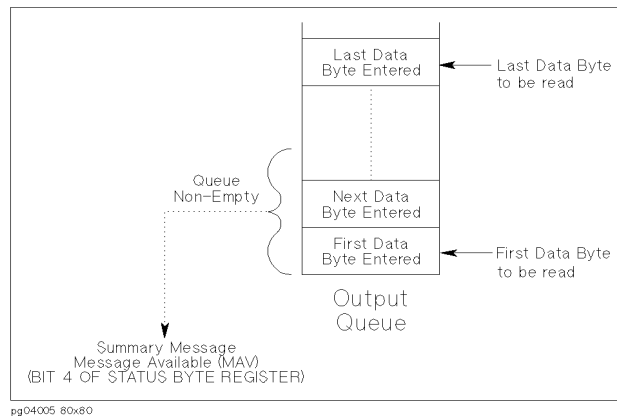

The Response Formatter places Data Byte Messages and END messages into the Output Queue in response to query commands. These messages are removed from the Output Queue as they are read by the controller. As long as the Output Queue contains an unread message, MAV is 1.

Operation Status Register

This register consists of CONDITION, TRANSITION FILTER, EVENT, and event enable (MASK) registers.

- You enable the desired bits of the EVENT register by using the MASK register. 1 enables, 0 masks the corresponding bit of EVENT register. The MASK register is set by the :STATus:OPERation:ENABLE command.
- The TRANSITION FILTER register consists of positive and negative transition filters.

If a bit in the *positive transition filter* is set to 1, then a 0 to 1 transition in the corresponding bit of the CONDITION register causes a 1 to be written in the corresponding EVENT register bit. The positive transition filter is set by the :STATus:OPERation:PTRansition command.

If a bit in the *negative transition filter* is set to 1, then a 1 to 0 transition in the corresponding bit of the CONDITION register causes a 1 to be written in the corresponding EVENT register bit. The negative transition filter is set by the :STATus:OPERation:NTRansition command.

See “STATus Subsystem” in Chapter 5 for details about these commands.

Figure 3-6

Operation Status Register

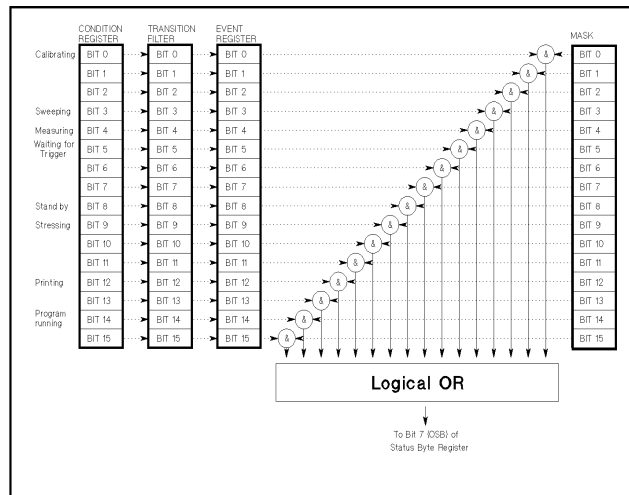

This is a standard SCPI register, but non-IEEE488.2.

Table 3-3

Operation Status Register

Bit	Definition	Explanation
0	Calibrating	4155C/4156C is currently performing a calibration.
1 to 2	NOT USED	Always zero.
3	Sweeping	A sweep is in progress.
4	Measuring	4155C/4156C is actively measuring (sweep or sampling measurement).
5	Waiting for Trigger	4155C/4156C is currently waiting for a trigger input.
6 to 7	NOT USED	Always zero.
8	Standby	4155C/4156C is currently in the standby state.
9	Stressing	4155C/4156C is currently in the stress forcing state.
10 to 11	NOT USED	Always zero.
12	Printing	A print/plot operation is in progress.
13	NOT USED	Always zero.
14	Program running	A user-defined program is currently in the run state.
15	NOT USED	Always zero.

Questionable Status Register

This register consists of CONDITION, TRANSITION FILTER, EVENT, and event enable (MASK) registers.

- You enable the desired bits of the EVENT register by using the MASK register. 1 enables, 0 masks the corresponding bit of EVENT register. The MASK register is set by the :STATus:QUEStionable:ENABle command.
- The TRANSITION FILTER register consists of positive and negative transition filters.

If a bit in the *positive transition filter* is set to 1, then a 0 to 1 transition in the corresponding bit of the CONDITION register causes a 1 to be written in the corresponding EVENT register bit. The positive transition filter is set by the :STATus:QUEStionable:PTRansition command.

If a bit in the *negative transition filter* is set to 1, then a 1 to 0 transition in the corresponding bit of the CONDITION register causes a 1 to be written in the corresponding EVENT register bit. The negative transition filter is set by the :STATus:QUEStionable:NTRansition command.

See “STATus Subsystem” in Chapter 5 for details about these commands.

Figure 3-7

Questionable Status Register

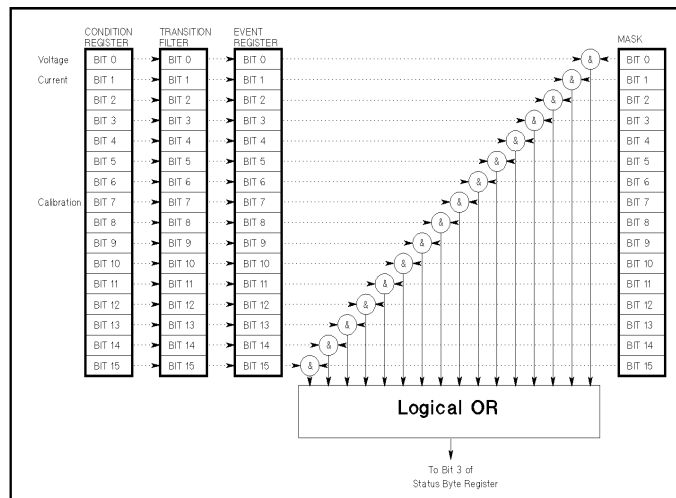

This is a standard SCPI register, but non-IEEE488.2.

Table 3-4 **QUEStionable Status Register**

Bit	Definition	Explanation
0	Voltage	This bit indicates whether the 4155C/4156C forced or measured voltage without error.
1	Current	This bit indicates whether the 4155C/4156C forced or measured current without error.
2 to 6	NOT USED	These bits are always zero.
7	CALibration	This bit indicates whether the 4155C/4156C completed the self-calibration without error.
8 to 15	NOT USED	These bits are always zero.

Emergency Status Register

This register consists of EVENT and event enable (MASK) registers.

You enable the desired bits of the EVENT register by using the MASK register. 1 enables, 0 masks the corresponding bit of EVENT register. The MASK register is set by the :STATus:EMERgency:ENABLE command. See “STATus Subsystem” in Chapter 5 for details about this command.

Figure 3-8 Emergency Status Register

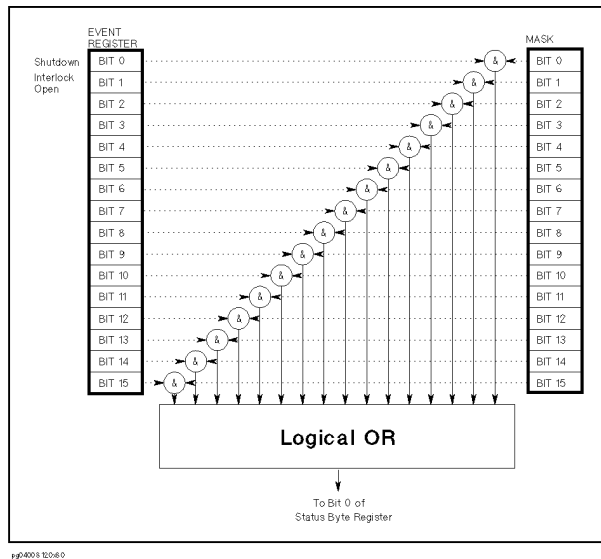

This register is not a standard SCPI register.

Table 3-5 EMERGENCY Status Register

Bit	Definition	Explanation
0	Shut down	This bit is set when SMU output is shut down by the instrument to prevent damage to SMU.
1	Interlock open	This bit is set when the fixture lid is opened.
2 to 15	NOT USED	These bits are always zero.

Measurement/Stress Status Register

This register consists of EVENT and event enable (MASK) registers.

You enable the desired bits of the EVENT register by using the MASK register. 1 enables, 0 masks the corresponding bit of EVENT register. The MASK register is set by the :STATUS:MEASurement:ENABLE command. See “STATUS Subsystem” in Chapter 5 for details about this command.

Figure 3-9 Measurement/Stress Status Register

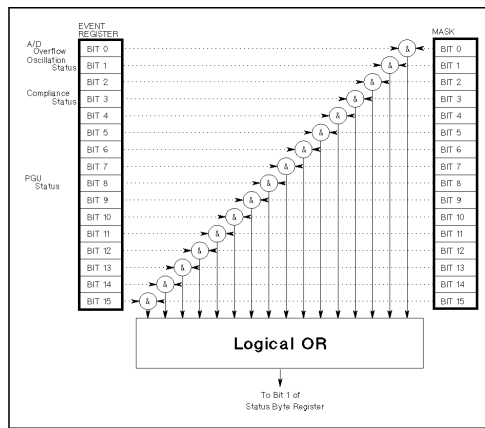

This register is not a standard SCPI register.

Table 3-6 Measurement/Stress Status Register

Bit	Definition	Explanation
0	A/D Overflow	This bit is set if A/D converter overflows.
1	Oscillation Status	This bit is set if SMU oscillates.
2	NOT USED	This bit is always zero.
3	Compliance Status	This bit is set if SMU reaches compliance.
4 to 7	NOT USED	These bits are always zero.
8	PGU Status	This bit is set if PGU reaches the current limit.
9 to 15	NOT USED	These bits are always zero.

Status Reporting Structure
Measurement/Stress Status Register

Common Commands

This chapter describes common commands and queries of *IEEE 488.2*.

The following table shows some common commands that are supported for the 4155C/4156C.

Table 4-1

Common Commands

Mnemonic	Name
*CAL?	Calibration Query
*CLS	Clear Status
*ESE(?)	Standard Event Status Enable Command (Query)
*ESR?	Standard Event Status Register Query
*IDN?	Identification Query
*OPC(?)	Operation Complete Command (Query)
*OPT?	Option Identification Query
*PCB	Pass Control Back Command
*RST	Reset Command
*SRE(?)	Service Request Enable Command (Query)
*STB?	Read Status Byte Query
*TRG	Trigger Command
*TST?	Self-Test Query
*WAI	Wait-to-Continue Command

*CAL?

This query command performs a full calibration of the instrument, then returns a <numeric_value> to indicate the calibration result.

Query response

error_no <newline><^END>

<i>error_no</i>	Explanation
0	PASS
1	FAIL

Response data type is NR1.

Example

```
OUTPUT @Hp4155;"*CAL?"  
ENTER @Hp4155;A
```

Common Commands

*CLS

***CLS**

This command clears the Status Byte Register, the Standard Event Status Register, and the Error Queue. This command does *not* clear the enable registers. Refer to Chapter 3.

Also, this command stops the monitoring of pending operations by the *OPC command.

This command does not have query form.

Syntax

*CLS

Example

```
OUTPUT @HP4155; " *CLS "
```

*ESE

This command sets the bits of the Standard Event Status "Enable" Register. 1 enables, 0 masks.

Syntax

*ESE *mask_number*

Parameter

Parameter	Type	Explanation
<i>mask_number</i>	decimal or non-decimal numeric	numeric value that is the sum of the binary-weighted values for the desired bits

Query response

mask_number <newline><^END>

mask_number is decimal numeric value that is the sum of the binary-weighted values for each bits. Response data type is NR1.

Semantics

The Standard Event Status "Enable" Register determines which bits of the Standard Event Status Register are enabled. Enabled bits are ORed together, and the result is reported to bit5 of the Status Byte Register.

The Standard Event Status "Enable" Register consists of 16 bits, but only the lower 8 bits are used, which correspond to the bits of the Standard Event Status Register.

Refer to Chapter 3 for details about the Standard Event Status "Enable" Register operation.

You can send a *mask_number* parameter in decimal numeric or non-decimal numeric type.

Common Commands

*ESE

The following table shows the bits of the Standard Event Status Register and binary-weighted decimal value.

bit	binary-weight	description
0	1	OPC (Operation Complete)
1	2	RQC (Request Control)
2	4	QYE (Query ERROR)
3	8	DDE (Device-Dependent ERROR)
4	16	EXE (Execution ERROR)
5	32	CME (Command ERROR)
6	64	NOT USED
7	128	PON (Power on)

Example

The following four lines enable the same bit (CME bit):

```
OUTPUT @Hp4155;"*ESE 32"           using decimal numeric
OUTPUT @Hp4155;"*ESE #B100000"    using binary numeric
OUTPUT @Hp4155;"*ESE #Q40"        using octal numeric
OUTPUT @Hp4155;"*ESE #H20"        using hexadecimal numeric
```

The following is example for query:

```
OUTPUT @Hp4155;"*ESE?"
ENTER @Hp4155;A
```

*ESR?

This query command returns the present contents of the Standard Event Status Register.

Syntax

*ESR?

Query response

register <newline><^END>

Parameter	Type	Explanation
<i>register</i>	NR1	0 to 255 (decimal integer value that is the sum of the binary-weighted values for the set bits)

Semantics

The following table shows the bits of the Standard Event Status Register. Refer to Chapter 3 for details about the register.

bit	binary-weight	description
0	1	OPC (Operation Complete)
1	2	RQC (Request Control)
2	4	QYE (Query ERROR)
3	8	DDE (Device-Dependent ERROR)
4	16	EXE (Execution ERROR)
5	32	CME (Command ERROR)
6	64	URQ NOT USED
7	128	PON (Power on)

Example

```
OUTPUT @Hp4155;"*ESR?"
ENTER @Hp4155;A
```

Common Commands

*IDN?

*IDN?

This query command returns the ID of your 4155C/4156C.

Syntax

*IDN?

Query response

HEWLETT-PACKARD,*model*,0,*revision* <newline><^END>

Response	Type	Explanation
<i>model</i>	character	4155C or 4156C
<i>revision</i>	character	<i>HOSTC revision</i> : <i>SMUC revision</i> : <i>ADC revision</i>

Example

```
DIM A$ [50]
OUTPUT @Hp4155;"*IDN?"
ENTER @Hp4155;A$
PRINT A$
```

An example result of above program is:

```
HEWLETT-PACKARD, 4155C, 0, 01.00:01.00:01.00
```

*OPC

This command starts to monitor pending operations, and sets/clears the Operation Complete (OPC) bit in the Standard Event Status Register as follows:

- If there is no pending operation, sets the OPC bit to 1.
- If there are any pending operations, sets the OPC bit to 0. The bit will be set to 1 again when all pending operations are completed.

So, *OPC command is required to enable the OPC bit. To stop monitoring pending operations (disable OPC bit), execute the *CLS command.

For details about the Standard Event Status Register, refer to Chapter 3. Also, see *WAI command.

When the operations initiated by the following commands are finished, the OPC bit in the Standard Event Status Register is set:

- :PAGE:SCONtrol[:MEASurement]:SINGle
- :PAGE:SCONtrol[:MEASurement]:APPend
- :PAGE:SCONtrol:STRes[:START]
- :PAGE:SCONtrol:KSWeep[:START]
- :DIAGnostic:TEST[:EXECute]
- :HCOPy[:IMMEDIATE]
- :HCOPy:ITEM:ALL[:IMMEDIATE]
- :HCOPy:ITEM[:WINDow]:TRACe[:IMMEDIATE]
- :HCOPy:SDUMp[:IMMEDIATE]

Syntax

*OPC

Query response

1 <newline><^END>

*OPC? places ASCII character 1 into the Output Queue when all pending operations are completed.

For details about the Output Queue, refer to Chapter 3.

Example

```
OUTPUT @Hp4155; "*OPC"
```

The following example is for query:

```
OUTPUT @Hp4155; "*OPC?"  
ENTER @Hp4155;A
```

*OPT?

*OPT?

This query command returns the reportable device options, which are the units in the expander.

Syntax

*OPT?

Query response

0 | GNDU, 0 | SMU5, 0 | SMU6, 0 | PGU <newline><^END>

Example

```
DIM A$[20]
OUTPUT @Hp4155;"*OPT?"
ENTER @Hp4155;A$
```

*PCB

This command is used to tell a potential controller which address should be used when passing control back.

This command does not have query form.

Syntax

*PCB *address* { ,*second_address* }

Parameter

Parameter	Type	Explanation
<i>address</i>	numeric	0 to 30
<i>second_address</i>	numeric	0 to 30

Common Commands

*RST

***RST**

This command performs an instrument reset.

Syntax

*RST

***SRE**

This command sets the Service Request "Enable" Register bits.

1 enables, 0 masks.

Syntax

*SRE *mask number*

Parameter

Parameter	Type	Explanation
<i>mask_number</i>	decimal or non-decimal numeric	numeric value that is the sum of the binary-weighted values for the desired bits

Query response

mask_number <newline><^END>

mask_number is decimal numeric value that is the sum of the binary-weighted values for each bits. Response data type is NR1.

Semantics

The Service Request "Enable" Register determines which bits of the Status Byte Register are enabled. Enabled bits are ORed together, and the result is reported to the Master Summary Status.

The Service Request "Enable" Register consists of 8 bits: Bit0 to Bit7. Bit6 is not defined, and is always 0.

Refer to Chapter 3 for details about the Service Request "Enable" Register.

You can send a *mask_number* parameter in decimal numeric or non-decimal numeric type.

The following table shows the bits of the Status Byte Register.

bit	binary-weight	description
0	1	EMERgency Status
1	2	Measurement/Stress Status
2	4	NOT USED
3	8	QUEStionable Status

Common Commands

*SRE

bit	binary-weight	description
4	16	MAV (Message Available summary-message)
5	32	ESB (Event Status Bit)
6	64	MSS (Master Summary Status)
7	128	OPERation Status

Example

The following following four lines enable the same bits (bit 7, 4, 1):

```
OUTPUT @Hp4155;"*SRE 146"      using decimal numeric
OUTPUT @Hp4155;"*SRE #B10010010" using binary numeric
OUTPUT @Hp4155;"*SRE #Q222"    using octal numeric
OUTPUT @Hp4155;"*SRE #H92"     using hexadecimal numeric
```

The following is example for query:

```
OUTPUT @Hp4155;"*SRE?"
ENTER @Hp4155;A
```

*STB?

This query command reads the Status Byte Register (reads Master Summary Status bit, not Request for Service Message).

Syntax

*STB?

Query response

register <newline><^END>

Parameter	Type	Explanation
<i>register</i>	NR1	0 to 255 (decimal integer value that is the sum of the binary-weighted values for the set bits)

Semantics

The following table shows the bits of the Status Byte Register.

bit	binary-weight	description
0	1	EMERgency Status
1	2	Measurement/Stress Status
2	4	NOT USED
3	8	QUESTionable Status
4	16	MAV (Message Available summary-message)
5	32	ESB (Event Status Bit)
6	64	MSS (Master Summary Status)
7	128	OPERation Status

Example

```
OUTPUT @Hp4155;"*STB?"
ENTER @Hp4155;A
```

***TRG**

This command causes the following action depending on present display page.

- If the present display page is the Stress Group page (STRESS CHANNEL DEFINITION, STRESS SETUP or STRESS FORCE), this command starts the stress force operation.

This action is as same as PAGE:SCONtrol:STress[:START] command.

- If the present display page is KNOB SWEEP page, this command generates error "Init ignored"(-213).
- If the present display page is not the Stress Group page or KNOB SWEEP page, this command starts the single measurement operation.

This action is as same as PAGE:SCONtrol[:MEASurement]:SINGle command.

If this command is received while the 4155C/4156C is in the measurement or stress state, this command generates error "Init ignored"(-213).

Syntax

*TRG

*TST?

This query command executes an internal self-test, then returns the result.

Syntax

*TST?

Query response

pass/fail_code <newline><^END>

<i>pass/fail code</i>	Explanation
0	pass
1	fail

Example

```
OUTPUT @Hp4155;"*TST?"
ENTER @Hp4155;A
```

Common Commands

*WAI

***WAI**

This command stops execution of any commands until the Operation Complete (OPC) bit is set to 1, which means there is no pending operation. Refer to *OPC command.

Syntax

*WAI

Example

```
OUTPUT @Hp4155;"*WAI"
```

SCPI Commands

This chapter explains the SCPI commands available for Agilent 4155C/4156C in alphabetical order.

SCPI commands

SCPI is a universal programming language for electronic test and measurement instruments, and based on IEEE 488.1 and IEEE 488.2.

SCPI commands are divided into two types: subsystem commands and common commands.

- Subsystem commands

Subsystem commands are mostly measurement related and some are general purpose. Subsystem commands have a hierarchical structure distinguished by the colon used between keywords.

The following subsystems are included:

CALibration	performs system calibration.
DIAGnostic	performs system diagnostics.
DISPlay	controls display condition.
FORMat	sets a data format for transferring numeric and array information.
HCOPY	performs print/plot function.
MMEMory	provides mass storage capability.
PAGE	defines the fields on the user interface pages of the 4155C/4156C and controls the user interface page operation.
PROGram	generates and controls the user-defined Instrument BASIC program resident in an instrument.
STATus	controls the status reporting structures.
SYSTEM	controls other functions, which are not related to instrument performance.
TRACe DATA	provides user variable operation.

- Common commands

Common commands are not measurement related, and are defined by IEEE 488.2. All common commands begin with an asterisk, such as *RST. Refer to Chapter 4.

Textual Notation**CAPITAL
LETTERS**

Capital letters are the minimally required letters of the command or query program header. Lowercase letters are the long form (complete spelling), which you can omit if desired.

< >

Angular brackets indicate that the word or words enclosed represent something other than themselves.

[]

Square brackets are used to enclose optional information not required for execution of the command sequence.

|

The vertical bar can be read as "or" and is used to separate alternative parameter options.

{ }

Braces (or curly brackets) are used to enclose one or more parameters that may be included zero or more times.

NOTE**CMD? Command**

This command returns the current control language mode of the 4155C/4156C. This command has only the query form.

Syntax CMD?

Query response *language_mode* <terminator>

language_mode is NR1 response data type.

<terminator> depends on the language mode.

The values of *language_mode* and <terminator> are as follows:

Value	Control Language Mode	<terminator>
0	SCPI command control mode	<LF^EOI>
1	Agilent FLEX command control mode (US mode or US42 mode)	<LF^EOI>
2	4145 syntax command control mode	<CR/LF^EOI>

Example

```
OUTPUT @Hp4155;"CMD?"
ENTER @Hp4155;A
```

CALibration Subsystem

The CALibration subsystem has the function of performing system calibration.

The following table is the command tree of CALibration subsystem.

Command	Parameter
:CALibration	
[:ALL] ?	
:AUTO	0 1 OFF ON
:ERRor?	<test_number>
:SElected?	<test_number>

:CALibration[:ALL]?

This command performs a full calibration of the instrument, then returns a numeric_value that indicates the result of the calibration.

A zero is returned if calibration is completed successfully. Otherwise, one is returned.

In addition to the error reported by this query response, the 4155C/4156C still reports calibration errors through the normal status-reporting mechanism.

This command has query form *only*.

Syntax

:CALibration [:ALL] ?

Query response

result <newline><^END>

Result	Explanation
0	PASS
1	FAIL

The data type of *result* is NR1 response data.

Example

```
OUTPUT @Hp4155; ":CAL?"
ENTER @Hp4155;A
```

SCPI Commands
:CALibration:AUTO

:CALibration:AUTO

This command sets whether the instrument automatically performs calibration every 30 minutes.

At *RST, this value is set to OFF.

Syntax :CALibration: AUTO OFF | ON | 0 | 1

Parameter

Parameter	Type	Explanation
OFF or 0	boolean	Do not perform auto calibration
ON or 1	boolean	Perform auto calibration

Query response 0 | 1 <newline><^END>

Example
OUTPUT @Hp4155;":CAL:AUTO ON"
OUTPUT @Hp4155;":CAL:AUTO?"
ENTER @Hp4155;A

:CALibration:ERRor?

This command returns a list of the calibration error numbers for the specified calibration item.

A zero is returned if no errors are detected.

If more than seven errors are detected, only the first seven errors are returned.

Syntax

:CALibration:ERRor? *test_number*

Parameter

Parameter	Type	Explanation
<i>test_number</i>	numeric	item number of the calibration
		111 : ALL Unit
		100 : VSU1,2/VMU1,2
		101 : SMU1
		102 : SMU2
		103 : SMU3
		104 : SMU4
		105 : SMU5
		106 : SMU6
		107 : PGU1,2
		108 : GNDU
		109 : ADC

Query response

error_list <newline><^END>

error_list is a comma-separated list of error numbers.

The data type of *error_list* is string response data, but does not contain double quote characters at the beginning and end of the string.

When no errors are detected, 0 is returned.

Example

```
OUTPUT @Hp4155;":CAL:ERR? 101"
ENTER @Hp4155;A$
```

SCPI Commands
:CALibration:SElected?

:CALibration:SElected?

This command performs the specified calibration item (*test_number*) of the instrument, then returns a number that indicates the calibration result.

A zero is returned if calibration is completed successfully. Otherwise, a non-zero value (error number) is returned.

In addition to the error reported by this query response, the 4155C/4156C still reports calibration errors through the normal status-reporting mechanism.

This command has query form *only*.

Syntax

:CALibration:SElected? *test_number*

Parameter

Parameter	Type	Explanation
<i>test_number</i>	numeric	item number of the calibration
		100 : VSU1,2/VMU1,2
		101 : SMU1
		102 : SMU2
		103 : SMU3
		104 : SMU4
		105 : SMU5
		106 : SMU6
		107 : PGU1,2
		108 : GNDU
		109 : ADC

Query response

result <newline><^END>

Result	Explanation
0	PASS
1	FAIL
2	DONE
3	NOT DONE

Example

```
OUTPUT @Hp4155;":CAL:SEL? 101"  
ENTER @Hp4155;A
```

DATA | TRACe Subsystem

DATA | TRACe subsystem sets or loads user variables and reads out the values of other data variables.

The following table is the command tree of DATA subsystem.

Command	Parameter
:DATA TRACe	
:CATalog?	
[:DATA]	<variable_name>, (<block> <numeric_value> {,<numeric_value>})
:DEFine	<variable_name> [,<numeric_value>]
:DELete	
:ALL	
[:NAME]	<variable_name>
:FREE?	
:POINTs	<variable> [,<numeric_value>]
:UNIT	<variable_name> [,<unit>]
:STATus?	<variable_name>

SCPI Commands
:DATA|:TRACe:CATalog?

:DATA|:TRACe:CATalog?

This command returns a comma-separated list that contains the names of scientific constant, read out functions, and all data variables.

The data variables are:

- VNAMEs and INAMEs defined by :PAGE:CHANnels:CDEFinition subsystem.
- User functions defined by :PAGE:CHANnels:UFUNction subsystem.
- User variables defined by :DATA | :TRACe subsystem (this subsystem).
- PGU output data defined by :PAGE:MEASure:PGUSetup subsystem.
- Time data of sampling measurement
- Index of the measurement result data.

If no data variables are defined, a single empty string is returned.

This command has query form *only*.

Syntax :DATA | :TRACe:CATalog?

Query response *data_variable_list* <newline><^END>

data_variable_list is string response data type, but does not contain double quote characters at the beginning and end of the string.

Example
OUTPUT @Hp4155;" :DATA:CAT?"
ENTER @Hp4155;A\$

:DATA|:TRACe[:DATA]

This command assigns the specified values to the specified *user variable*.

The user variable must first be defined by the :DATA|:TRACe:DEFine or :PAGE:CHANnels:UVARiable:DEFine command, or on the CHANNELS: USER VARIABLE DEFINITION page.

To transfer a block of data (REAL), you must set up the format by using FORMat Subsystem commands. Block transfer is fast because the block is directly loaded into the specified user variable.

To transfer ASCII data, the default is ASCII, so you do not need to set up the format unless you changed it to REAL. ASCII transfer is slower than block transfer because the data is transferred in ASCII, then converted and loaded into the specified user variable.

If the data source is a single *numeric_value*, each element of the specified user variable is set to the *numeric_value*.

Also, you can specify a different *numeric_value* for each element of the user variable.

If the number of *numeric_values* are less than the defined size of user variable, the remaining data elements are filled with last sent data.

If too many *numeric_values* are sent, the 4155C/4156C generates error -223 (too much data), and the extra data are ignored.

The query of this command returns the data values for the specified *data variable*, according to the format determined by commands in the FORMat subsystem. For the possible data variables that you can specify, see the previous command (:DATA:CATalog?).

Syntax

```
:DATA | :TRACe [ :DATA] user_variable_name,(block_data | numeric_value
{ ,numeric_value } )
```

Query syntax is as follows:

```
:DATA | :TRACe [ :DATA]? data_variable_name
```

SCPI Commands
:DATA|:TRACe[:DATA]

Parameter

Parameter	Type	Explanation
<i>user_variable_name</i>	string or character	user variable name to fill
<i>block</i>	arbitrary block	block of data whose format is determined by the FORMat Subsystem
<i>numeric_value</i>	numeric	numeric value

When *user_variable_name* is sent as character parameter type, all alpha characters are treated as uppercase in the 4155C/4156C.

Query response *data_variable_data* <newline><^END>

The data format of *data_variable_data* is determined by the FORMat Subsystem (ASCIi or REAL).

Example

```
OUTPUT @Hp4155;":TRAC 'Vdata',1,2,3,4,5"  
OUTPUT @Hp4155;":TRAC? 'Vdata'"  
ENTER @Hp4155;A(*)
```

:DATA|:TRACe:DEFine

This command defines (allocates and initializes) a new user variable.

The first parameter specifies the new user variable name. The second parameter specifies the size of user variable.

A new user variable is allocated with the specified number of data elements. The user variable is initialized with invalid data.

If the second parameter is omitted, the new user variable size is the number of VARI steps for sweep measurement, or the number of the sample points for sampling measurement mode.

This command does not have query form.

Syntax

:DATA | :TRACe:DEFine *user_variable_name* [, *user_variable_size*]

Parameter

Parameter	Type	Explanation
<i>user_variable_name</i>	string or character	user variable name to define
<i>user_variable_size</i>	numeric	size of the user variable

When *user_variable_name* is sent as character parameter type, all alpha characters are treated as upper case in the 4155C/4156C.

Example

```
OUTPUT @Hp4155;":TRAC:DEF 'Vdata',1024"
```

SCPI Commands
:DATA|:TRACe:DELeTe:ALL

:DATA|:TRACe:DELeTe:ALL

This command deletes all the user variable names on the CHANNELS: USER VARIABLE DEFINITION page.

This command does not have query form.

Syntax :DATA | :TRACe:DELeTe:ALL

Example OUTPUT @Hp4155;":TRAC:DEL:ALL"

:DATA|:TRACe:DELeTe[:NAME]

This command deletes the specified user variable name on the CHANNELS: USER VARIABLE DEFINITION page.

This command does not have query form.

Syntax :DATA | :TRACe:DELeTe [:NAME] *user_variable_name*

Parameter

Parameter	Type	Explanation
<i>user_variable_name</i>	string or character	user variable name to delete

When *user_variable_name* is sent in character program data format, all alpha characters are treated as upper case in the 4155C/4156C.

Example OUTPUT @Hp4155;":TRAC:DEL 'Vdata'"

:DATA|:TRACe:FREE?

This command returns the amount of user memory space available for data variables.

This command has query form *only*.

Syntax :DATA | :TRACe:FREE?

SCPI Commands
:DATA|:TRACe:STATus?

:DATA|:TRACe:STATus?

This command returns the status of the specified data variable.

This command has query form *only*.

Syntax

:DATA | :TRACe:STATus? *data_variable_name*

Parameter

Parameter	Type	Explanation
<i>data_variable_name</i>	string or character	data variable name

Query response

status <newline><<^END>

bit	binary-weight	description
0	1	Stack Register Overflow
1	2	Calculation error
2	4	Insufficient data
3	8	Not used (always 0)
4	16	A/D converter overflow occurs.
5	32	SMU or VSU oscillates.
6	64	Other SMU reaches its compliance setting.
7	128	This SMU reaches its compliance setting.
8 to 15		Not used (always 0)

If the ASCII transfer format was selected by the FORMat subsystem, *status* is an integer value that is the sum of the binary-weighted values for the bits in NR1 response data format.

If the REAL transfer format was selected by the FORMat subsystem, *status* is definite length block data with 16-bit integer format. The length of the returned block depends on the specified *data_variable_name*.

Example

```
OUTPUT @Hp4155;":TRAC:STAT? 'Vdata'"  
ENTER @Hp4155;A(*)
```

:DATA|:TRACe:UNIT

This command sets the unit for data of the specified user variable.

The user variable must first be defined by the :DATA | :TRACe:DEFine or :PAGE:CHANnels:UVAriable:DEFine command, or on the CHANNELS: USER VARIABLE DEFINITION page.

Syntax

:DATA | :TRACe:UNIT *user_variable_name* ,*unit*

Parameter

Parameter	Type	Explanation
<i>user_variable_name</i>	string or character	user variable name to specify unit for
<i>unit</i>	string	unit of the user variable data

Query response

unit <newline><^END>

Example

```
OUTPUT @Hp4155;":TRAC:UNIT 'Vdata','mV'"
OUTPUT @Hp4155;":TRAC:UNIT? 'Vdata'"
ENTER @Hp4155;A$
```

DIAGnostic Subsystem

The DIAGnostic subsystem has diagnostic functions that are used in routine maintenance and repair.

The following table is the command tree of DIAGnostic subsystem.

Command	Parameter
:DIAGnostic	
:TEST	
:ABORt	
:CONTinue	
:ERRor?	<test_number>
[:EXECute]	<test_number>
:RESult?	

:DIAGnostic:TEST:ABORt

This command forcibly terminates the diagnostics operation.

This command may set the Operation Complete flag to true since it terminates the executing diagnostics operation.

This command does not have query form.

Syntax :DIAGnostic:TEST:ABORt

Example OUTPUT @Hp4155;":DIAG:TEST:ABOR"

:DIAGnostic:TEST:CONTinue

This command is used for interactive testing.

For interactive testing, operation pauses to wait for operation by user.

This command continues the test from pause status.

This command does not have query form.

Syntax :DIAGnostic:TEST:CONTinue

Example OUTPUT @Hp4155;":DIAG:TEST:RES?"
ENTER @Hp4155;A
IF A=-1 THEN !-1 means pause status(waiting to continue)
 OUTPUT @Hp4155;":DIAG:TEST:CONT"
END IF

SCPI Commands
:DIAGnostic:TEST:ERRor?

:DIAGnostic:TEST:ERRor?

This command returns a list of error numbers for the specified diagnostic test item.

A zero is returned if no errors are detected.

If more than seven errors are detected, only the first seven errors are returned.

This command has query form *only*.

Syntax :DIAGnostic:TEST:ERRor? *test_number*

Parameter The definitions of *test_number* are the same as for the :DIAGnostic:TEST:EXECute command.

Query response *error_list* <newline><^END>

error_list is a list of comma-separated error numbers.

The data type of *error_list* is string response data but does not contain double quote at the beginning and end of the string.

Example OUTPUT @Hp4155;":DIAG:TEST:ERR? 101"
ENTER @Hp4155;A\$

See also :DIAGnostic:TEST:EXECute

:DIAGnostic:TEST[:EXECute]

This command performs the specified diagnostic test item (*test_number*) of the instrument.

This command sets the Operation Complete flag to false until the diagnostics initiated by this command finishes. This affects the execution of the *OPC, *OPC?, and *WAI commands.

This command does not have query form.

Syntax :DIAGnostic:TEST [:EXECute] *test_number*

Parameter

Parameter	Type	Explanation
<i>test_number</i>	numeric	item number of the diagnostic test

The following *test_number* values are available:

Unit test	Explanation
111	Test all units
100	VSU1, VSU2, VMU1, VMU2
101	SMU1
102	SMU2
103	SMU3
104	SMU4
105	SMU5
106	SMU6
107	PGU1, PGU2
108	GNDU
109	ADC

LCD test	Explanation
201	ALL White
202	ALL Red
203	ALL Green
204	ALL Blue
205	16 Step Gray Scale
212	Repeating Gray Scale
213	Color Rainbow
214	Character Set

CPU test	Explanation
311	All cpu tests
301	HOSTC DRAM
302	HOST Memories (ROM, SRAM)
303	Real Time Clock
305	Parallel I/F Controller
306	Host <-> SMUC I/F

SCPI Commands

:DIAGnostic:TEST[:EXECute]

CPU test	Explanation
307	SMUC Memories, Timer
308	Graphics Controllers
309	Graphic Memories
310	Sound Generator
312	LAN Interface ^a

a. Need to connect the LAN IF test adapter (Agilent Part Number 04155-61631).

NOTE

In Display Lock State

When the 4155C/4156C screen is set to the update disable state by :DISP OFF (or 0) command, available values for *test_number* are 100 to 111.

To execute *test_number* 201 to 413, enter :DISP ON (or 1) command.

IO Peripheral test	Explanation
401	Parallel I/F ^a
402	Trigger Input/Output
404	Flexible Disk Controller
405	Flexible Disk Read/Write
406	Post regulator
407	Front Key Circuit
409	Front Key LED
410	External Key Controller
412	SMU/PGU Selector Control
413	R-box Control

a. Need to connect the parallel IF test adapter (Agilent Part Number 04155-61632).

Example

```
OUTPUT @Hp4155;":DIAG:TEST 101"
```

:DIAG:TEST:RESult?

This query command returns the result of the diagnostic test.

Syntax

:DIAG:TEST:RESult?

Query response

result <newline><^END>

The data type of *result* is NR1 response data.

The *result* values have the following meaning.

result	Explanation
-2	Test in progress
-1	Not complete (now pause status waiting to continue)
0	PASS
1	FAIL
2	DONE
3	NOT DONE

Example

```
OUTPUT @Hp4155;":DIAG:TEST 101"
OUTPUT @Hp4155;":DIAG:TEST:RES?"
ENTER @Hp4155;A
```

DISPlay Subsystem

The DISPlay subsystem controls the display conditions.

The following table is the command tree of DISPlay subsystem.

Command	Parameter
:DISPlay	
:BRIGhtness	<numeric>
:CMAp	
:COLOr<n>	
:HSL	<hue>,<sat>,<lum>
:DEFault	
:CONTrast	<numeric>
[:WINDow]	
:ALLocation	INSTRument BASic BStatus
[:STATe]	0 1 OFF ON

:DISPlay:BRIGhtness

This command controls the intensity of the display.

At *RST, this value is 0.843.

Syntax :DISPlay:BRIGhtness *intensity* | MINimum | MAXimum

Parameter

Parameter	Type	Explanation
<i>intensity</i>	numeric	0.15 to 1. 1 is full intensity, and 0.15 is fully blanked.

Query response *intensity* <newline><^END>

The data type of *intensity* is NR3 response data.

Example

```
OUTPUT @Hp4155;":DISP:BRIG 0.5"
```

```
OUTPUT @Hp4155;":DISP:BRIG?"
```

```
ENTER @Hp4155;A
```

SCPI Commands
:DISPlay:CMAP:COLor<n>:HSL

:DISPlay:CMAP:COLor<n>:HSL

This command sets the instrument's color map based on the Hue/Saturation/Luminance color model.

<n> is required to specify the color numbers. Valid COLor numbers are COLor1 through COLor15.

Color Number	Explanation	Color Number	Explanation
1	Background	9	Advisory
2	Softkey Background	10	Y1 Axis
3	Active Field Background	11	Y2 Axis
4	Graph Background	12	Marker/Cursor/Line
5	Foreground	13	Active Mkr/Csr/Lne
6	Active Field Foreground	14	Overlay
7	Title	15	Grid
8	Frame		

Syntax

:DISPlay:CMAP:COLor<n>:HSL *hue* | MINimum | MAXimum,
sat | MINimum | MAXimum, *lum* | MINimum | MAXimum

Parameter

Parameter	Type	Explanation
<i>hue</i>	numeric	Hue ranges circularly from 0 to 1 with a value of 0 resulting in the same hue as a value of 1. The approximate color progression is (starting at 0): red, orange, yellow, green, cyan, blue, magenta, and back to red.
<i>sat</i>	numeric	Saturation is the amount of pure color to be mixed with white. The saturation value ranges from 0 to 1, with 0 specifying no color (only white or gray, depending on intensity) and 1 specifying no white.
<i>lum</i>	numeric	Luminance specifies the brightness per unit area of color. The luminance value ranges from 0 to 1. A luminance of 0 results in black; a luminance of 1 results in the brightest color variable.

Query response *hue, sat, lum* <newline><^END>

The data type of *hue, sat, and lum* are NR3 response data.

Example
 OUTPUT @Hp4155;":DISP:CMAP:COLor1:HSL 0.5,0.5,0.5"
 OUTPUT @Hp4155;":DISP:CMAP:COLor1:HSL?"
 ENTER @Hp4155;A,B,C

:DISPlay:CMAP:DEFault

This command sets the color map to the instrument's default values for all colors.

This command does not have query form.

Syntax :DISP:CMAP:DEFault

Example OUTPUT @Hp4155;":DISP:CMAP:DEF"

:DISPlay:CONTRast

The 4155C/4156C does not do anything by this command. This command is only for keeping the compatibility with the 4155A/4156A.

AT *RST, this value is 0.608.

Syntax :DISPlay:CONTRast *contrast* | MINimum | MAXimum

Parameter

Parameter	Type	Explanation
<i>contrast</i>	numeric	0 to 1. 0 means no difference between data and background, and 1 means maximum contrast.

Query response *contrast* <newline><^END>

The data type of *contrast* is NR3 response data.

Example
 OUTPUT @Hp4155;":DISP:CONT 0.5"
 OUTPUT @Hp4155;":DISP:CONT?"
 ENTER @Hp4155;A

SCPI Commands
:DISPlay[:WINDow]:ALLocation

:DISPlay[:WINDow]:ALLocation

This command controls the display allocation.

At RST, this value is set to "INST".

Syntax :DISPlay[:WINDow] :ALLocation INSTrument | BASic | BSTatus

Parameter

Parameter	Type	Explanation
INSTrument	character	display "All Instrument" screen
BASic	character	display "All IBASIC" screen
BSTatus	character	display "IBASIC Status" screen (instrument screen, but bottom three lines and softkeys are for IBASIC).

Query response INST | BAS | BST <newline><^END>

Example
OUTPUT @Hp4155;":DISP:ALL INS"
OUTPUT @Hp4155;":DISP:ALL?"
ENTER @Hp4155;A\$

:DISPlay[:WINDow][:STATe]

This command controls whether the instrument screen is updated or not.

AT *RST, this value is ON.

Syntax :DISPlay[:WINDow] [:STATe] OFF | ON | 0 | 1

Parameter

Parameter	Type	Explanation
OFF <i>or</i> 0	boolean	screen is not updated
ON <i>or</i> 1	boolean	screen is updated (update <i>enable</i> state)

Query response 0 | 1 <newline><<^END>

Remarks The :DISP OFF (or 0) command is *not* available when the 4155C/4156C screen displays the following page:

- SYSTEM: FILER
- SYSTEM: MISCELLANEOUS
- SYSTEM: CONFIGURATION
- SYSTEM: SELF-CALIBRATION/DIAGNOSTICS
- SYSTEM: PRINT/PLOT SETUP
- SYSTEM: COLOR SETUP
- KNOB SWEEP

To enter the following command, the 4155C/4156C screen must be set to the update *enable* state.

- :PAGE:KSweep command group
- :PAGE:SCONtrol:KSweep[:STARt] command
- :DIAGnostic:TEST[:EXECute] *test_no* command (*test_no*: 201 to 413)

Example

```
OUTPUT @Hp4155;":DISP ON"
OUTPUT @Hp4155;":DISP?"
ENTER @Hp4155;A
```

FORMat Subsystem

The FORMat subsystem sets a data format for transferring numeric and array information.

This data format is used for both command and response data by those commands that are specifically designated to be affected by the FORMat subsystem. The designation is either given as part of a command description, or in the definition of block or array data used by a command.

The data format for command data may override the definition of FORMat if the data received is self typing (indicates its type), for the duration of that data transfer.

The following table is the command tree of FORMat subsystem.

Command	Parameter
:FORMat	
:BORDER	NORMAL SWAPPED
[:DATA]	ASCII REAL{,<length>}

:FORMat:BORDER

This command controls whether binary data is transferred in normal or swapped byte order. To set up binary data transfer, you must specify `REAL` in the `:FORMat[:DATA]` command.

At `*RST`, this value is set to `NORMal`.

Syntax

:FORMat:BORDER NORMal | SWAPped

Parameter

Parameter	Type	Explanation
NORMal	character	Normal byte order.
SWAPped	character	Swapped byte order.

Query response

NORM | SWAP <newline><^END>

Example

OUTPUT @Hp4155;":FORM:BORD NORM"

OUTPUT @Hp4155;":FORM:BORD?"

ENTER @Hp4155;A\$

SCPI Commands
:FORMat[:DATA]

:FORMat[:DATA]

This command specifies the data format, which only has meaning for the :DATA|:TRACe:DEFine and :DATA|:TRACe:STATus commands.

For other commands, the query response is usually ASCII.

At *RST, this value is set to ASCii.

Syntax

:FORMat [:DATA] ASCii | REAL {,*length*}

Parameter

Parameter	Explanation
ASCii	Numeric data is transferred as ASCii bytes in NR1, NR2, or NR3 response data format, as appropriate. The numbers are separated by commas as specified in <i>IEEE 488.2</i> .
REAL	Data is transferred in a block of <i>IEEE 754</i> floating point numbers with the specified bit <i>length</i> . Valid <i>length</i> are 32 and 64 bits. (Default is 64 bits).

Query response

ASC | REAL, *length* <newline><^END>

The data type of *length* is NR1 response data.

Example

```
OUTPUT @Hp4155;":FORM ASC"  
OUTPUT @Hp4155;":FORM?"  
ENTER @Hp4155;A$
```

HCOPY Subsystem

The Hard COPY subsystem controls the print/plot function of the 4155C/4156C.

The following tables are the command tree of HCOPI subsystem.

Command	Parameter
:HCOPY	
:ABORT	
:DATA?	
:DESTINATION	PARALLEL RDEVICE MEMORY NET1 NET2 NET3 NET4
:DEVICE	
:CMOD	BW FULL FIX
:COLOR	0 1 OFF ON
:LANGUAGE	PCL HPGL HRPCL TIFF HRTIFF
:RESOLUTION	<numeric>
[:IMMEDIATE]	
:INIT	<string>
:ITEM	
:ALL	
:DATA?	
[:IMMEDIATE]	
:ANNOTATION	
:STATE	0 1 OFF ON
:ANNOTATION2	
:STATE	0 1 OFF ON

SCPI Commands

Command	Parameter
:HCOPY	
:ITEM	
:FFEed	
:STATE	0 1 OFF ON
:LABel	
:STATE	0 1 OFF ON
:TEXT	<string>
:PNUMber	
:STATE	0 1 OFF ON
:TDSTamp	
:STATE	0 1 OFF ON
[:WINDow]	
:TEXT	
:STATE	0 1 OFF ON
:TEXT2	
:STATE	0 1 OFF ON
:TEXT3	
:STATE	0 1 OFF ON
:TRACe	
:DATA?	
:GRATICule	
:STATE	0 1 OFF ON
[:IMMediate]	
:STATE	0 1 OFF ON
:LINDex	<numeric>, <numeric>

Command	Parameter
:HCOpy	
:OPAGe	CURRent GROUp ALL
:PAGE	
:COLumn	<numeric>
:DIMensions	
:LLEFt	<numeric>, <numeric>
:QUADranTn	
:URIGHt	<numeric>, <numeric>
:WHOLe	
:FDIREction	LSIDe SSIDe
:LENGth	<numeric>
:LINE	<numeric>
:SIZE	CUSTom A B A3 A4 B4 B5
:UNIT	IN MM
:WIDTh	<numeric>
:SDUMp	
:DATA?	
[:IMMEDIATE]	
:TRAILer	<string>

SCPI Commands
:HCOpy:ABORt

:HCOpy:ABORt

This command aborts the current print or plot operation.

This command does not have query form.

Syntax :HCOpy:ABORt

Example OUTPUT @Hp4155;":HCOP:ABOR"

:HCOpy:DATA?

This command returns hardcopy (PCL or HP-GL) data of the plot or print out.

The items to be returned have been selected by :HCOpy:ITEM subsystem commands.

This command has query form *only*.

Syntax :HCOpy:DATA?

Query response #0{data element} <newline><^END>

Response is in indefinite length arbitrary block response data format.

Example Refer to *Programmer's Guide*.

:HCOpy:DESTination

This command selects the print or plot destination.

If you use a remote printer via your print server, set the 4155C/4156C network setup and network printer setup on the SYSTEM: MISCELLANEOUS page, or enter the :SYST:COMM:NET:SELF commands and the following commands before executing this command.

- :SYST:COMM:NET:PRIN:NET:NAME
- :SYST:COMM:NET:PRIN:NET:IPAD
- :SYST:COMM:NET:PRIN:NET:TEXT
- :SYST:COMM:NET:PRIN:NET:GRAP
- :SYST:COMM:NET:PRIN:NET:TYPE
- :SYST:COMM:NET:PRIN:SET

This command does not have query form.

This command has no *RST state and you must use this command before printing or plotting.

Syntax

:HCOPY:DESTINATION PARallel | RDEvice | NET1 | NET2 | NET3 | NET4 |
MMEMory

Parameter

Parameter	Type	Explanation
PARallel	character	parallel port
RDEvice	character	GPIB port
NET1	character	printer set by :SYST:COMM:NET:PRIN:SET NET1 or assigned to the top softkey for the PRINTER field on the SYSTEM: MISCELLANEOUS screen.
NET2	character	printer set by :SYST:COMM:NET:PRIN:SET NET2 or assigned to the second softkey for the PRINTER field on the SYSTEM: MISCELLANEOUS screen.
NET3	character	printer set by :SYST:COMM:NET:PRIN:SET NET3 or assigned to the third softkey for the PRINTER field on the SYSTEM: MISCELLANEOUS screen.
NET4	character	printer set by :SYST:COMM:NET:PRIN:SET NET4 or assigned to the fourth softkey for the PRINTER field on the SYSTEM: MISCELLANEOUS screen.
MMEMory	character	Not make hardcopy. Outputs to a file in the mass storage device specified by the :MMEM:DEST command. File name is specified by :MMEM:NAME command.

Example

OUTPUT @Hp4155;":HCOP:DEST RDEV"

See also

:MMEMory:NAME
:SYSTem:COMMunicate:NETwork[:SELF]
:SYSTem:COMMunicate:NETwork:PRINter:NET
:SYSTem:COMMunicate:NETwork:PRINter:SET

SCPI Commands
:HCOpy:DEVice:CMOD

:HCOpy:DEVice:CMOD

This command selects color mode for hardcopy.

At *RST, the value of this parameter is BW.

Syntax

:HCOpy:DEVice:CMOD BW | FULL | FIX

Parameter

Parameter	Type	Explanation
BW	character	monochrome mode
FULL	character	color mode for HP-GL or PCL printers that have sixteen color capability, for example, HP DeskJet 1200C and HP PaintJet. You can make a color print that has exactly the same colors as display.
FIX	character	color mode for HP-GL pen plotters and PCL color printers that have only eight color capability, for example, HP DeskJet 500C, 550C, and 560C.

NOTE

FIX mode

By PCL color printer, you can make a color copy that uses eight fixed colors: black, red, green, yellow, blue, magenta, cyan, and white.

You can change the color to print or pen assignment for each screen item by using the SYSTEM: COLOR SETUP page. For details, refer to "SYSTEM: COLOR SETUP screen" in Chapter 5 of *User's Guide: General Information*.

Although this mode allows only the eight fixed colors, this mode is also available for HP-GL or PCL printers that have sixteen color capability.

Query response

BW | FULL | FIX <newline><<^END>

Example

```
OUTPUT @Hp4155;":HCOpy:DEV:CMOD FIX"  
OUTPUT @Hp4155;":HCOpy:DEV:CMOD?"  
ENTER @Hp4155;A$
```

:HCOPY:DEvice:COLor

This command is just to keep compatibility with the 4155A/4156A. Use :HCOPY:DEvice:CMOD instead of this command.

This command selects color or monochrome (black/white) mode.

At *RST, the value of this parameter is OFF.

Syntax

:HCOPY:DEvice:COLor OFF | ON | 0 | 1

Parameter

Parameter	Type	Explanation
OFF <i>or</i> 0	boolean	monochrome mode
ON <i>or</i> 1	boolean	color mode for the HP-GL or PCL printers which have sixteen colors capability, for example, HP DeskJet 1200C and HP PaintJet. You can get a color copy which uses exactly same colors as display.

Query response

0 | 1 <newline><<^END>

Example

OUTPUT @Hp4155;":HCOP:DEV:COL ON"

OUTPUT @Hp4155;":HCOP:DEV:COL?"

ENTER @Hp4155;A

SCPI Commands
:HCOPY:DEVice:LANGuage

:HCOPY:DEVice:LANGuage

This command selects the printer or plotter control language.

At *RST, this value is set to PCL.

Syntax

:HCOPY:DEVice:LANGuage PCL | HPGL | HRPCl | TIFF | HRTiff

Parameter

Parameter	Type	Explanation
PCL	character	Printer Control Language (PCL)
HRPCl	character	high resolution PCL
HPGL	character	Hewlett-Packard's Graphics Language (HP-GL)
TIFF	character	Tagged Image File Format (TIFF)
HRTiff	character	high resolution TIFF

Query response

PCL | HPGL | HRPCl | TIFF | HRTiff <newline><^END>

Example

```
OUTPUT @Hp4155;":HCOP:DEV:LANG PCL"
```

```
OUTPUT @Hp4155;":HCOP:DEV:LANG?"
```

```
ENTER @Hp4155;A$
```

:HCOPY:DEVice:RESolution

This command sets the resolution of the print out on the printer.

This command is effective only if the printer or plotter control language is set to PCL by :HCOP:DEV:LANG command.

At *RST, this value is set to 75 DPI.

Syntax

:HCOPY:DEVice:RESolution *resolution* | MINimum | MAXimum

Parameter

Parameter	Type	Explanation
<i>resolution</i>	numeric	75, 90, 100, 150, 180, 300, 600 (DPI) Suffix is not allowed.

Query response *resolution* <newline><^END>
The data type of *resolution* is NR1 response data.

Example
OUTPUT @Hp4155;":HCOP:DEV:RES 75"
OUTPUT @Hp4155;":HCOP:DEV:RES?"
ENTER @Hp4155;A

:HCOPY[:IMMediate]

This command immediately initiates the plot or print according to the current setup.

The output items to be plotted or printed out are the items selected by the :HCOPY:ITEM subsystem commands.

This command does not have query form.

Syntax :HCOPY [:IMMediate]

Example
OUTPUT @Hp4155;":HCOP"

:HCOPY:INIT

This command sets INIT STRING, which are initialization commands you want to send to the printer or plotter.

At *RST, this value is set to the empty string.

Syntax :HCOPY:INIT *init_string*

Parameter

Parameter	Type	Explanation
<i>init_string</i>	string	initialization commands

You can specify non-printable ASCII characters by a backslash and octal code (ASCII code). For example, \033 specifies the <ESC> character.

Query response *init_string* <newline><^END>

Example
OUTPUT @Hp4155;":HCOP:INIT '\033E'"
OUTPUT @Hp4155;":HCOP:INIT?"
ENTER @Hp4155;A\$

SCPI Commands
:HCOPY:ITEM:ALL:DATA?

:HCOPY:ITEM:ALL:DATA?

This command returns hardcopy (PCL or HP-GL) data of all output items, including items not selected by the :HCOPY:ITEM subsystem commands.

This command has query form *only*.

Syntax :HCOPY:ITEM:ALL:DATA?

Query response #0{*data element*} <newline><^END>

Response is in indefinite length arbitrary block response data format.

:HCOPY:ITEM:ALL[:IMMEDIATE]

This command immediately plots or prints all output items, including items not selected by the :HCOPY:ITEM subsystem commands.

This command does not have query form.

Syntax :HCOPY:ITEM:ALL [:IMMEDIATE]

Example OUTPUT @Hp4155;":HCOPY:ITEM:ALL"

:HCOPY:ITEM:ANNOTATION:STATE

This command sets whether the title of the print or plot out (TITLE) should be plotted or printed when the :HCOPY:IMMEDIATE command or :HCOPY:DATA? query is sent.

At *RST, the value of this parameter is ON.

Syntax :HCOPY:ITEM:ANNOTATION:STATE OFF | ON | 0 | 1

Parameter

Parameter	Type	Explanation
OFF <i>or</i> 0	boolean	Title is not plotted or printed.
ON <i>or</i> 1	boolean	Title is plotted or printed.

Query response 0 | 1 <newline><^END>

Example

```
OUTPUT @Hp4155;":HCOP:ITEM:ANN:STAT ON"
OUTPUT @Hp4155;":HCOP:ITEM:ANN:STAT?"
ENTER @Hp4155;A
```

:HCOPY:ITEM:ANNotation2:STATe

This command sets whether the user defined comment for each page group (USER COMMENT) should be plotted or printed when the :HCOPY:IMMediate command or :HCOPY:DATA? query is sent.

At *RST, the value of this parameter is ON.

Syntax :HCOPY:ITEM:ANNotation2:STATe OFF | ON | 0 | 1

Parameter

Parameter	Type	Explanation
OFF <i>or</i> 0	boolean	USER COMMENT is not plotted or printed.
ON <i>or</i> 1	boolean	USER COMMENT is plotted or printed.

Query response 0 | 1 <newline><^END>

Example

```
OUTPUT @Hp4155;":HCOP:ITEM:ANN2:STAT ON"
OUTPUT @Hp4155;":HCOP:ITEM:ANN2:STAT?"
ENTER @Hp4155;A
```

SCPI Commands
:HCOPY:ITEM:FFEd:STATe

:HCOPY:ITEM:FFEd:STATe

This command sets whether the printer or plotter feeds a sheet after plot or print out by the :HCOPY:IMMEDIATE command or :HCOPY:DATA? query.

At *RST, the value of this parameter is OFF.

Syntax :HCOPY:ITEM:FFEd:STATe OFF | ON | 0 | 1

Parameter

Parameter	Type	Explanation
OFF <i>or</i> 0	boolean	Disable form feed function
ON <i>or</i> 1	boolean	Enable form feed function

Query response 0 | 1 <newline><<^END>

Example
OUTPUT @Hp4155;":HCOP:ITEM:FFE:STAT ON"
OUTPUT @Hp4155;":HCOP:ITEM:FFE:STAT?"
ENTER @Hp4155;A

:HCOPY:ITEM:LABel:STATe

This command sets whether the user defined comment for the plot or print out (PRINT/PLOT COMMENT), which is defined by :HCOPY:ITEM:LABel:TEXT command, should be plotted or printed when the :HCOPY:IMMEDIATE command or :HCOPY:DATA? query is sent.

At *RST, the value of this parameter is ON.

Syntax :HCOPY:ITEM:LABel:STATe OFF | ON | 0 | 1

Parameter

Parameter	Type	Explanation
OFF <i>or</i> 0	boolean	PRINT/PLOT COMMENT is not plotted or printed.
ON <i>or</i> 1	boolean	PRINT/PLOT COMMENT is plotted or printed.

Query response 0 | 1 <newline><<^END>

Example

```
OUTPUT @Hp4155;":HCOP:ITEM:LAB:STAT ON"
OUTPUT @Hp4155;":HCOP:ITEM:LAB:STAT?"
ENTER @Hp4155;A
```

See also :HCOPY:ITEM:LABel:TEXT

:HCOPY:ITEM:LABel:TEXT

This command defines the user defined comment for the plot or print out (PRINT/PLOT COMMENT).

If the PRINT/PLOT COMMENT is an empty string, it will be plotted or printed as a single blank line.

At *RST, this comment is set to empty string.

Syntax :HCOPY:ITEM:LABel:TEXT *string*

Parameter

Parameter	Type	Explanation
<i>string</i>	string	PRINT/PLOT COMMENT

Query response *string* <newline><^END>

Example

```
OUTPUT @Hp4155;":HCOP:ITEM:LAB:TEXT 'DEVICE:A NO.123'"
OUTPUT @Hp4155;":HCOP:ITEM:LAB:TEXT?"
ENTER @Hp4155;A$
```

SCPI Commands
:HCOPY:ITEM:TDSTamp:STATe

:HCOPY:ITEM:TDSTamp:STATe

This command sets whether the present date and time of the built-in clock (DATE&TIME) should be plotted or printed when the :HCOPY:IMMediate command or :HCOPY:DATA? query is sent.

At *RST, the value of this parameter is ON.

Syntax

:HCOPY:ITEM:TDSTamp:STATe OFF | ON | 0 | 1

Parameter

Parameter	Type	Explanation
OFF <i>or</i> 0	boolean	DATE&TIME is not plotted or printed.
ON <i>or</i> 1	boolean	DATE&TIME is plotted or printed.

Query response

0 | 1 <newline><<^END>

Example

```
OUTPUT @Hp4155;":HCOP:ITEM:TDST:STAT ON"  
OUTPUT @Hp4155;":HCOP:ITEM:TDST:STAT?"  
ENTER @Hp4155;A
```

:HCOPY:ITEM:PNUMber:STATe

This command sets whether the page number of the plot or print out (PAGE NO.) should be plotted or printed when the :HCOPY:IMMediate command or :HCOPY:DATA? query is sent.

At *RST, the value of this parameter is ON.

This command does not comply with SCPI.

Syntax

:HCOPY:ITEM:PNUMber:STATe OFF | ON | 0 | 1

Parameter

Parameter	Type	Explanation
OFF <i>or</i> 0	boolean	PAGE NO is not plotted or printed.
ON <i>or</i> 1	boolean	PAGE NO is plotted or printed.

Query response 0 | 1 <newline><<^END>

Example
 OUTPUT @Hp4155;":HCOP:ITEM:PNUM:STAT ON"
 OUTPUT @Hp4155;":HCOP:ITEM:PNUM:STAT?"
 ENTER @Hp4155;A

:HCOPY:ITEM[:WINDow]:TEXT:STATe

This command sets whether the GRAPH TEXT (marker and cursor coordinate values, data variables, and line parameters) should be plotted or printed when the :HCOPY:IMMediate command or :HCOPY:DATA? query is sent.

At *RST, the value of this parameter is ON.

Syntax :HCOPY:ITEM [:WINDow] :TEXT:STATe OFF | ON | 0 | 1

Parameter

Parameter	Type	Explanation
OFF <i>or</i> 0	boolean	GRAPH TEXT is not plotted or printed.
ON <i>or</i> 1	boolean	GRAPH TEXT is plotted or printed.

This command has meaning only when :HCOPY:DEvice:LANGUage is set to HP-GL. If set to PCL, GRAPH TEXT is always printed or plotted.

Query response 0 | 1 <newline><<^END>

Example
 OUTPUT @Hp4155;":HCOP:ITEM:TEXT:STAT ON"
 OUTPUT @Hp4155;":HCOP:ITEM:TEXT:STAT?"
 ENTER @Hp4155;A

SCPI Commands
:HCOPY:ITEM[:WINDow]:TEXT2:STATe

:HCOPY:ITEM[:WINDow]:TEXT2:STATe

This command sets whether the GRAPH AXIS TEXT (names, units, and scale of the graph axis) should be plotted or printed when the :HCOPY:IMMEDIATE command or :HCOPY:DATA? query is sent.

At *RST, the value of this parameter is ON.

This command does not comply with SCPI.

Syntax

:HCOPY:ITEM [:WINDow] :TEXT2:STATe OFF | ON | 0 | 1

Parameter

Parameter	Type	Explanation
OFF <i>or</i> 0	boolean	GRAPH AXIS TEXT is not plotted or printed.
ON <i>or</i> 1	boolean	GRAPH AXIS TEXT is plotted or printed.

This command has meaning only when :HCOPY:DEVIce:LANGUage is set to HP-GL. If set to PCL, GRAPH AXIS TEXT is always printed or plotted.

Query response

0 | 1 <newline><^END>

Example

```
OUTPUT @Hp4155;":HCOP:ITEM:TEXT2:STAT ON"  
OUTPUT @Hp4155;":HCOP:ITEM:TEXT2:STAT?"  
ENTER @Hp4155;A
```

:HCOPY:ITEM[:WINDow]:TEXT3:STATe

This command sets whether the measurement setup data should be plotted or printed when the :HCOPY:IMMEDIATE command or :HCOPY:DATA? query is sent to output graphics results.

At *RST, the value of this parameter is OFF.

This command does not comply with SCPI.

Syntax

:HCOPY:ITEM [:WINDow] :TEXT3:STATe OFF | ON | 0 | 1

Parameter

Parameter	Type	Explanation
OFF <i>or</i> 0	boolean	Measurement setup data is not plotted or printed.
ON <i>or</i> 1	boolean	Measurement setup data is plotted or printed.

Query response 0 | 1 <newline><^END>

Example
 OUTPUT @Hp4155;":HCOP:ITEM:TEXT3:STAT ON"
 OUTPUT @Hp4155;":HCOP:ITEM:TEXT3:STAT?"
 ENTER @Hp4155;A

:HCOPY:ITEM[:WINDow]:TRACe:DATA?

This command returns hardcopy (PCL or HP-GL) data of the graphics plot curve on the GRAPH/LIST: GRAPHICS page.

This command also changes the current display to GRAPH/LIST: GRAPHICS page.

This command has query form *only*.

Syntax :HCOPY:ITEM [:WINDow] :TRACe:DATA?

Query response #0{*data element*} <newline><^END>

Example Refer to *Programmer's Guide*

SCPI Commands

:HCOPY:ITEM[:WINDow]:TRACe:GRATICule:STATe

:HCOPY:ITEM[:WINDow]:TRACe:GRATICule:STATe

This command sets whether the frame and grid on the GRAPH/LIST: GRAPHICS page (GRAPH FRAMEGRID) should be plotted or printed when the HCOpy:IMMediate command or HCOpy:DATA? query is sent.

At RST, the value of this parameter is ON.

Syntax

:HCOPY:ITEM [:WINDow] :TRACe:GRATICule:STATe OFF | ON | 0 | 1

Parameter

Parameter	Type	Explanation
OFF <i>or</i> 0	boolean	GRAPH FRAMEGRID is not plotted or printed.
ON <i>or</i> 1	boolean	GRAPH FRAMEGRID is plotted or printed.

This command has meaning only when :HCOPY:DEvIce:LANGUage is set to HP-GL. If set to PCL, GRAPH FRAMEGRID is always printed or plotted.

Query response

0 | 1 <newline><<^END>

Example

```
OUTPUT @Hp4155;":HCOP:ITEM:TRAC:GRAT:STAT ON"
OUTPUT @Hp4155;":HCOP:ITEM:TRAC:GRAT:STAT?"
ENTER @Hp4155;A
```

:HCOPY:ITEM[:WINDow]:TRACe[:IMMediate]

This command immediately plots or print outs the graphics plot curve of the GRAPH/LIST: GRAPHICS page.

This command also changes the current display to GRAPH/LIST: GRAPHICS page.

This command does not have query form.

Syntax

:HCOPY:ITEM [:WINDow] :TRACe [:IMMediate]

Example

```
OUTPUT @Hp4155;":HCOP:ITEM:TRAC"
```

:HCOPY:ITEM[:WINDow]:TRACe:STATe

This command sets whether the graphics plot curve on the GRAPH/LIST: GRAPHICS page (GRAPH TRACE) should be plotted or printed when the :HCOPY:IMMEDIATE command or :HCOPY:DATA? query is sent.

At *RST, the value of this parameter is ON.

Syntax

:HCOPY:ITEM [:WINDow] :TRACe:STATe OFF | ON | 0 | 1

Parameter

Parameter	Type	Explanation
OFF <i>or</i> 0	boolean	GRAPH TRACE is not plotted or printed.
ON <i>or</i> 1	boolean	GRAPH TRACE is plotted or printed.

This command has meaning only when :HCOPY:DEVIce:LANGUage is set to HP-GL. If set to PCL, GRAPH TRACE is always printed or plotted.

Query response

0 | 1 <newline><^END>

Example

```
OUTPUT @Hp4155;":HCOP:ITEM:TRAC:STAT ON"  
OUTPUT @Hp4155;":HCOP:ITEM:TRAC:STAT?"  
ENTER @Hp4155;A
```

SCPI Commands
:HCOpy:LINDex

:HCOpy:LINDex

This command specifies the range of measurement results to output by using index numbers.

You use this command only if the current display page is GRAPH/LIST: LIST.

This command also changes the value of :MMEMemory:STORe:SSHeet:LINDex.

At *RST, this value is set to (1,MAX).

This command does not comply with SCPI.

Syntax

:HCOpy:LINDex *first* | MINimum | MAXimum, *last* | MINimum | MAXimum

Parameter

Parameter	Type	Explanation
<i>first</i>	numeric	first index number to output
<i>last</i>	numeric	last index number to output

Query response

first,last <newline><^END>

The data type of *first* and *last* are NR1 response data.

Example

```
OUTPUT @Hp4155;":HCOP:LIND 1,MAX"
```

```
OUTPUT @Hp4155;":HCOP:LIND?"
```

```
ENTER @Hp4155;A,B
```

See also

:MMEMemory:STORe:SSHeet:LINDex

:HCOpy:OPAGe

This command sets the range of the setup data to be output.

At *RST, this value is set to CURRent.

Syntax

:HCOpy:OPAGe CURRent | GROup | ALL

Parameter

Parameter	Type	Explanation
CURR	character	setup data of <i>only the page</i> where the print/plot function is invoked.
GRO	character	setup data of the <i>page group</i> where the print/plot function is invoked.
ALL	character	all setup data.

Query response CURR | GRO | ALL <newline><^END>

Example
 OUTPUT @Hp4155;":HCOP:OPAG CURR"
 OUTPUT @Hp4155;":HCOP:OPAG?"
 ENTER @Hp4155;A\$

:HCOPY:PAGE:COLumn

This command sets the number of characters (columns) in one line of the print out. At *RST, the value of this parameter is 80.

Syntax :HCOPY:PAGE:COLumn *column*

Parameter

Parameter	Type	Explanation
<i>column</i>	numeric	number of characters in a line.

Query response *column* <newline><^END>

The data type of *column* is NR1 response data.

Example
 OUTPUT @Hp4155;":HCOP:PAGE:COL 80"
 OUTPUT @Hp4155;":HCOP:PAGE:COL?"
 ENTER @Hp4155;A

See also :HCOPY:DEVICE:LANGuage

SCPI Commands
:HCOPY:PAGE:DIMensions:LLEft

:HCOPY:PAGE:DIMensions:LLEft

This command sets the lower left corner of the output region.

At *RST, the value of this parameter is (0,0).

Syntax

:HCOPY:PAGE:DIMensions:LLEft *x* | MINimum | MAXimum,
y | MINimum | MAXimum

Parameter

Parameter	Type	Explanation
<i>x</i>	numeric	percentage from the left side of the paper
<i>y</i>	numeric	percentage from the bottom of the paper

Query response

x, *y* <newline><^END>

The data type of *x* and *y* are NR3 response data.

Example

OUTPUT @Hp4155;":HCOP:PAGE:DIM:LLEF 10,90"

OUTPUT @Hp4155;":HCOP:PAGE:DIM:LLEF?"

ENTER @Hp4155;A,B

:HCOPY:PAGE:DIMensions:QUADrant<n>

This command sets LOWER LEFT and UPPER RIGHT so that the setup data is printed on the upper right quarter, upper left quarter, lower left quarter, or lower right quarter of the page.

A numeric suffix is required to specify the quadrant.

<n>	quadrant
1	upper right quarter
2	upper left quarter
3	lower left quarter
4	lower right quarter

This command defines an event and thus has no *RST state or query form.

Syntax :HCOPY:PAGE:DIMensions:QUADrant<n>

Example OUTPUT @Hp4155;":HCOP:PAGE:DIM:QUAD1"

See also :HCOPY:PAGE:DIMensions:LLEFt, :HCOPY:PAGE:DIMensions:URIGht

:HCOPY:PAGE:DIMensions:URIGht

This command sets the upper right corner of the output region.

At *RST, the value of this parameter is (100,100).

Syntax :HCOPY:PAGE:DIMensions:URIGht *x*, *y*

Parameter

Parameter	Explanation
<i>x</i>	percentage from the left side of the paper
<i>y</i>	percentage from the bottom of the paper

Query response *x*, *y* <newline><^END>

The data type of *x* and *y* are NR3 response data.

Example OUTPUT @Hp4155;":HCOP:PAGE:DIM:URIG 90,10"
OUTPUT @Hp4155;":HCOP:PAGE:DIM:URIG?"
ENTER @Hp4155;A,B

:HCOPY:PAGE:DIMensions:WHOLE

This command sets the output region to *full* size available for the paper.

Syntax :HCOPY:PAGE:DIMensions:WHOLe

Example OUTPUT @Hp4155;":HCOP:PAGE:DIM:WHOL"

SCPI Commands
:HCOPY:PAGE:FDIRrection

:HCOPY:PAGE:FDIRrection

This command sets the direction of the paper-feed into the plotter.

At *RST, the value of this parameter is SSIDe.

Syntax

:HCOPY:PAGE:FDIRrection SSIDe | LSIDe

Parameter

Parameter	Type	Explanation
SSIDe	character	Direction is shorter side of the paper
LSIDe	character	Direction is longer side of the paper

Query response

SSID | LSID <newline><^END>

Example

```
OUTPUT @Hp4155;":HCOP:PAGE:FDIR SSID"  
OUTPUT @Hp4155;":HCOP:PAGE:FDIR?"  
ENTER @Hp4155;A$
```

:HCOPY:PAGE:LENGth

This command sets the vertical length of the paper.

Unit of length is set by :HCOPY:PAGE:UNIT command.

At *RST, the value of this parameter is set to 11 inch.

Syntax

:HCOPY:PAGE:LENGth *length* | MINimum | MAXimum

Parameter

Parameter	Explanati on	
<i>length</i>	numeric	vertical length of the paper 7 to 20 (inch) or 177.793 to 507.98 (mm)

Query response

length <newline><^END>

The data type of *length* is NR3 response data.

Example OUTPUT @Hp4155;":HCOP:PAGE:LENG 10"
 OUTPUT @Hp4155;":HCOP:PAGE:LENG?"
 ENTER @Hp4155;A

See also :HCOPY:PAGE:UNIT

:HCOPY:PAGE:LINE

This command sets the number of lines on a page.

At *RST, the value of this parameter is 60.

This command does not comply with SCPI.

Syntax :HCOPY:PAGE:LINE *length*

Parameter

Parameter	Type	Explanation
<i>length</i>	numeric	number of lines on a page

Query response *length* <newline><^END>

Example OUTPUT @Hp4155;":HCOP:PAGE:LINE 60"
 OUTPUT @Hp4155;":HCOP:PAGE:LINE?"
 ENTER @Hp4155;A

See also :HCOPY:DEVIce:LANGuage

SCPI Commands
:HCOpy:PAGE:SIZE

:HCOpy:PAGE:SIZE

This command sets the paper size.

If :HCOpy:PAGE:LENGth or :HCOpy:PAGE:WIDTh are set, the value of this setting becomes CUSTom.

At *RST, the value of this parameter is CUSTom.

Syntax

:HCOpy:PAGE:SIZE CUSTom | A | B | A3 | A4 | B4 | B5

Parameter

Parameter	Type	Explanation
CUSTom	character	size is defined by LENGth and WIDTh
A, B, A3, A4, B4, B5	character	A, B, A3, A4, B4, B5 size

Query response

CUST | A | B | A3 | A4 | B4 | B5 <newline><^END>

A (letter) = 8.5 by 11 in, B = 11 by 17 in, A3 = 297 by 420 mm A4 = 210 by 297 mm, B4 = 257 by 364 mm, B5 = 182 by 257 mm.

Example

OUTPUT @Hp4155;":HCOpy:PAGE:SIZE A4"

OUTPUT @Hp4155;":HCOpy:PAGE:SIZE?"

ENTER @Hp4155;A\$

See also

:HCOpy:PAGE:LENGth, :HCOpy:PAGE:WIDTh

:HCOpy:PAGE:UNIT

This command sets the unit for LENGth and WIDTh.

At *RST, the value of this parameter is IN (inch).

Syntax

:HCOpy:PAGE:UNIT IN | MM

Parameter

Parameter	Type	Explanation
IN	character	inch
MM	character	millimeter

Query response IN | MM <newline><^END>

Example
 OUTPUT @Hp4155;":HCOP:PAGE:UNIT IN"
 OUTPUT @Hp4155;":HCOP:PAGE:UNIT?"
 ENTER @Hp4155;A\$

See also :HCOPY:PAGE:LENGTh, :HCOPY:PAGE:WIDTh

:HCOPY:PAGE:WIDTh

This command sets the horizontal width of the paper.
 Unit of width is set by :HCOPY:PAGE:UNIT command.
 At *RST, the value of this parameter is set to 8.5 inch.

Syntax :HCOPY:PAGE:WIDTh *width*

Parameter

Parameter	Type	Explanation
<i>width</i>	numeric	width of the paper

Query response *width* <newline><^END>

The data type of *width* is NR3 response data.

Example
 OUTPUT @Hp4155;":HCOP:PAGE:WIDTh 10"
 OUTPUT @Hp4155;":HCOP:PAGE:WIDTh?"
 ENTER @Hp4155;A

See also :HCOPY:PAGE:UNIT

SCPI Commands
:HCOPY:SDUMp:DATA?

:HCOPY:SDUMp:DATA?

This command returns hardcopy (PCL or HP-GL) data of the current screen image.

This command has query form *only*.

Syntax :HCOPY:SDUMp:DATA?

Query response #0{*data element*} <newline><^END>

Response is in indefinite length arbitrary block response data format.

Example Refer to *Programmer's Guide*

:HCOPY:SDUMp[:IMMEDIATE]

This command plots or prints out the current screen image.

This command does not have query form.

Syntax :HCOPY:SDUMp [:IMMEDIATE]

Example OUTPUT @Hp4155;":HCOPY:SDUM"

:HCOPY:TRAILer

This command sets the TRAILER STRING, which are the commands you want to send to the printer or plotter after printing or plotting.

At *RST, this value is set to the empty string.

Syntax :HCOPY:TRAILer *trailer_string*

Parameter

Parameter	Type	Explanation
<i>trailer_string</i>	string	trailer string

You can specify non-printable ASCII characters by backslash and octal code (ASCII code). For example, \033 specifies the <ESC> character.

Query response *trailer_string* <newline><^END>

Example
 OUTPUT @Hp4155;":HCOP:TRA '\033E'
 OUTPUT @Hp4155;":HCOP:TRAILER?"
 ENTER @Hp4155;A\$

MMEMory Subsystem

The MMEMory (Mass MEMory) subsystem provides mass storage capabilities.

You can select one from the available mass memory devices: internal memory, built-in flexible disk drive and file system on your NFS server. But the internal memory is a restricted mass memory device, which has only four fixed names (MEM1, MEM2, MEM3, MEM4) and their file extensions for data type (MES, STR, DAT or MAT).

The following table is a command tree of MMEMory subsystem.

Command	Parameter
:MMEMory	
:CATalog?	[<msus>]
:CDIRectory	<dir_name> [,<msus>]
:COPY	<file_name>, <file_name> <file_name>, <msus>, <file_name>, <msus>
:DELete	file_name [,msus]
:DESTination	INTernal NET1 NET2 NET3 NET4
:INITialize	{LIF DOS}
:LOAD	
:STATe	<state_no>, <file_name> [,<msus>]
:TRACe	<label>, <file_name> [,<msus>]
:MOVE	<file_name>, <file_name> <file_name>, <msus>, <file_name>, <msus>
:NAME	<file_name> [,<msus>]
:STORE	
:SSheet	<file_name>
:DELimiter	SPACe TAB COMMa
:LINDEX	<numeric>, <numeric>
:SMARK	NONE DQUote SQUote
:UNIT	OFF ON 0 1
:STATe	<state_no>, <file_name> [,<msus>]
:TRACe	<label>, <file_name> [,<msus>]

:MMEMory:CATalog?

This command returns information about the present contents and state of the mass storage that specified by the :MMEM:DEST command.

Syntax :MMEMory:CATalog? [*msus*]

Parameter

Parameter	Type	Explanation
<i>msus</i>	string	mass storage (Only 'DISK' can be entered as the value)

Query response

used,available { , file_entry_list }<newline><^END>

The *used* indicates the remaining amount of storage currently used in bytes. The data type of *used* is NR1 response data. If NET1, NET2, NET3 or NET4 is set by the :MMEM:DEST command, *used* returns 0 (zero).

The *available* indicates the remaining amount of storage available in bytes. The data type of *available* is NR1 response data. If NET1, NET2, NET3 or NET4 is set by the :MMEM:DEST command, *available* returns 0 (zero).

The *file_entry_list* is a list of *file_entrys* separated by commas. The data type of *file_entry_list* is string response data format, but does not contain double quote characters at the beginning and end of the string.

Each *file_entry* indicates the name, type, and size of one file.

file_entry = *file_name*, *file_type*, *file_size*

The *file_name* is the name of a file including the extension.

The *file_size* is the size of the file in bytes.

The *file_type* is indicated by one of the following:

- ASC ASCII text file
- BIN binary file
- STAT instrument (setting) state
- TRAC trace (display) data
- MACR instrument macro

The following is the example of the *file_entry_list*:

```
BTR.MES,STAT,3833,GENE.MES,STAT,3833,VDS-ID.MES,STAT,3833
```

SCPI Commands
:MMEMory:CDIRectory

Example The following two examples show the same result.

```
OUTPUT @Hp4155;":MMEM:CAT?"  
ENTER @Hp4155;A,B,C$
```

```
OUTPUT @Hp4155;":MMEM:CAT? 'DISK'"  
ENTER @Hp4155;A,B,C$
```

See also :MMEMory:DESTination

:MMEMory:CDIRectory

This command changes the working directory on the NFS server specified by :MMEM:DEST command.

Before entering this command, the :MMEM:DEST command must set the present mass storage device to NET1, NET2, NET3 or NET4.

Query returns the present working directory.

Syntax :MMEMory:CDIRectory *dir_name* [, *msus*]

Parameter

Parameter	Type	Explanation
<i>dir_name</i>	string	Next working directory name
<i>msus</i>	string	mass storage (Only 'DISK' can be entered as the value)

Query response *directory* <newline><^END>

directory means the present working directory.

Example The following two examples produce the same result.

```
OUTPUT @Hp4155;":MMEM:CDIR 'next_dir'"  
OUTPUT @Hp4155;":MMEM:CDIR 'next_dir','DISK'"
```

Query Example:

```
OUTPUT @Hp4155;":MMEM:CDIR?"  
ENTER @Hp4155;A$
```

See also :MMEMory:DESTination

:MMEMory:COPY

This command copies an existing file to a new file.

If the source file doesn't exist or the destination file already exists, an error is generated.

This command does not have query form.

Syntax

- Syntax 1:
:MMEMory:COPY *src_file*, *dest_file*
- Syntax 2:
:MMEMory:COPY *src_file*, *src_msus*, *dest_file*, *dest_msus*

Parameter

Parameter	Type	Explanation
<i>src_file</i>	string	source file name including extension
<i>dest_file</i>	string	destination file name including extension
<i>src_msus</i>	string	source mass storage ('DISK' or 'MEMORY' is available)
<i>dest_msus</i>	string	destination mass storage ('DISK' or 'MEMORY' is available)

The default mass storage is the device specified by :MMEM:DEST command. You must specify file extension with the file name. To specify the device, set *src_msus* and/or *dest_msus* to 'DISK', or use Syntax 1.

If you copy an internal memory data, set *src_msus* and/or *dest_msus* to 'MEMORY'. The extension is optional, so file name can be MEM1, MEM2, MEM3, or MEM4 or with applicable file type extension (MES, STR, DAT, or MAT).

Example

To copy a file to another file on the default device:

```
OUTPUT @Hp4155;":MMEM:COPY 'CMOS.MES', 'CMOS2.MES'"
```

To copy an internal memory data to a file in the default device:

```
OUTPUT @Hp4155;":MMEM:COPY 'MEM3.MES', 'MEMORY', 'CMOS.MES', 'DISK'"
```

To copy an internal memory data to another internal memory:

```
OUTPUT @Hp4155;":MMEM:COPY 'MEM3.MES', 'MEMORY', 'MEM4', 'MEMORY'"
```

SCPI Commands
:MMEMory:DELeTe

:MMEMory:DELeTe

This command removes a file from the mass storage device specified by the :MMEM:DEST command.

This command does not have query form.

Syntax

:MMEMory:DELeTe *file_name* [, *msus*]

Parameter

Parameter	Type	Explanation
<i>file_name</i>	string	file name including extension
<i>msus</i>	string	mass storage ('DISK' or 'MEMORY' is available)

The default mass storage is the device specified by the :MMEM:DEST command. To specify the device, set *msus* to 'DISK', or ignore *msus* parameter.

If you delete an internal memory data, set *msus* to 'MEMORY'. The file name must be MEM1, MEM2, MEM3, or MEM4 with file type extension (MES, STR, DAT, or MAT).

Example

To delete a file from the default mass storage device:

```
OUTPUT @Hp4155;":MMEM:DEL 'CMOS.MES' "
```

To delete data in an internal memory:

```
OUTPUT @Hp4155;":MMEM:DEL 'MEM3.MES' , 'MEMORY' "
```

:MMEMory:DESTination

This command sets either the built-in flexible disk drive or the file system on your NFS server as the mass storage device. You must enter this command before doing file operation.

This command has no *RST state. This command also has a query form.

Execution Conditions

To use the file system on your NFS server, do one of below. The :MMEM:DEST command makes the NFS mount immediately.

Set the 4155C/4156C network setup and network drive setup on the SYSTEM: MISCELLANEOUS screen.

Enter the commands of the :SYST:COMM:NET:SELF group and the following commands to set the 4155C/4156C network setup and network drive setup:

- :SYST:COMM:NET:FILE:NET:NAME
- :SYST:COMM:NET:FILE:NET:IPAD
- :SYST:COMM:NET:FILE:NET:DIR
- :SYST:COMM:NET:FILE:SET

Syntax

:MMEMory:DESTination INTernal | NET1 | NET2 | NET3 | NET4
:MMEMory:DESTination?

Parameter

See Table 5-1.

Query response

INT | NET1 | NET2 | NET3 | NET4 <newline><^END>

Example

```
OUTPUT @Hp4155;":MMEM:DEST NET3"  
OUTPUT @Hp4155;":MMEM:DEST?"  
ENTER @Hp4155;A$
```

See also

:SYSTem:COMMunicate:NETwork[:SELF]
:SYSTem:COMMunicate:NETwork:FILE:NET
:SYSTem:COMMunicate:NETwork:FILE:SET

SCPI Commands
:MMEMory:DESTination

Table 5-1

:MMEMory:DESTination Command Parameter

Parameter	Type	Explanation
INTernal	character	Built-in flexible disk drive. In the Power On state, INTernal is set.
NET1	character	The drive assigned to the top softkey of the LABEL field on the SYSTEM: MISCELLANEOUS screen or set by the :SYST:COMM:NET:FILE:SET NET1 command.
NET2	character	The drive assigned to the second softkey of the LABEL field on the SYSTEM: MISCELLANEOUS screen or set by the :SYST:COMM:NET:FILE:SET NET2 command.
NET3	character	The drive assigned to the third softkey of the LABEL field on the SYSTEM: MISCELLANEOUS screen or set by the :SYST:COMM:NET:FILE:SET NET3 command.
NET4	character	The drive assigned to the fourth softkey of the LABEL field on the SYSTEM: MISCELLANEOUS screen or set by the :SYST:COMM:NET:FILE:SET NET4 command.

:MMEMory:INITialize

This command initializes the diskette that is in the built-in flexible disk drive.

This command does not have query form.

Syntax

:MMEMory:INITialize { DOS | LIF }

Parameter

Parameter	Type	Explanation
DOS	character	MS-DOS format
LIF	character	LIF format

The default setting is "DOS".

Example

```
OUTPUT @Hp4155;":MMEM:INIT DOS"
```

SCPI Commands
:MMEMory:LOAD:STATe

:MMEMory:LOAD:STATe

This command loads the specified setup data from the mass memory device specified by the :MMEM:DEST command.

This command does not have query form.

Execution Conditions

If you load a MAT file, enter the :PAGE:CHANnels:MATrix:CONTROL ON command before this command.

Syntax

:MMEMory:LOAD:STATe *state_no*, *file_name* [, *msus*]

Parameter

Parameter	Type	Explanation
<i>state_no</i>	numeric	no meaning for 4155C/4156C. 0 is recommended.
<i>file_name</i>	string	file name.
<i>msus</i>	string	mass storage ('DISK' or 'MEMORY' is available)

The default mass storage is the device set by the :MMEM:DEST command. To specify the device, set *msus* to 'DISK', or ignore *msus* parameter. You must specify file extension with the file name.

If you load the data from an internal memory, set *msus* to 'MEMORY'. The extension is optional, so file name can be MEM1, MEM2, MEM3, or MEM4 or with applicable file type extension (MES, STR, or MAT).

Example

Following two examples produce the same result.

```
OUTPUT @Hp4155;":MMEM:LOAD:STAT 0, 'CMOS.MES'"
```

```
OUTPUT @Hp4155;":MMEM:LOAD:STAT 0, 'CMOS.MES', 'DISK'"
```

:MMEMory:LOAD:TRACe

This command loads the measurement data from specified mass memory device.

This command defines does not have query form.

Syntax

:MMEMory:LOAD:TRACe *label*, *file_name* [, *msus*]

Parameter

Parameter	Type	Explanation
<i>label</i>	character	Default only
<i>file_name</i>	string	file name.
<i>msus</i>	string	mass storage ('DISK' or 'MEMORY' is available)

The default mass storage is the device set by the :MMEM:DEST command. To specify the device, set *msus* to 'DISK', or ignore *msus* parameter. You must specify file extension with the file name.

If you load the data from an internal memory, set *msus* to 'MEMORY'. The extension is optional, so file name can be MEM1, MEM2, MEM3, or MEM4 or with file extension (DAT).

Example

```
OUTPUT @Hp4155;":MMEM:LOAD:TRAC DEF, 'MEM1', 'MEMORY'"
```

SCPI Commands
:MMEMory:MOVE

:MMEMory:MOVE

This command moves (renames) an existing file to another file name.

Both the source and destination files must be on the device specified by the :MMEM:DEST command.

If the specified source file does not exist, error -256 "File name not found" will be generated.

If the specified destination file already exists, error -257 "File name error" will be generated.

This command does not have query form.

Syntax

:MMEMory:MOVE *src_file* , *dest_file*

or

:MMEMory:MOVE *src_file* , *src_msus* , *dest_file* , *dest_msus*

Parameter

Parameter	Type	Explanation
<i>src_file</i>	string	source file name including extension
<i>dest_file</i>	string	destination file name including extension
<i>src_msus</i>	string	source mass storage (Only 'DISK' can be set as the value)
<i>dest_msus</i>	string	destination mass storage (Only 'DISK' can be set as the value)

Example

The following two examples produce the same result.

```
OUTPUT @Hp4155;":MMEM:MOVE 'CMOS.MES', 'CMOS2.MES'"
```

```
OUTPUT @Hp4155;":MMEM:MOVE 'CMOS.MES', 'DISK', 'CMOS2.MES', 'DISK'"
```

:MMEMory:NAME

This command sets the name of the file for saving hardcopy image.

Before entering this command, do following:

- Set the mass storage using the :MMEM:DEST command.
- Set the hardcopy destination to file using the :HCOP:DEST MMEM command.

AT *RST, this value is a null string.

Syntax

:MMEMory:NAME *file_name* [, *msus*]

Parameter

Parameter	Type	Explanation
<i>file_name</i>	string	file name
<i>msus</i>	string	mass storage (Only 'DISK' can be entered as the value)

Query response

file_name <newline><^END>

The data type of *file_name* is string response data, but does not contain double quote characters at the beginning and end of the string.

Example

```
OUTPUT @Hp4155;":MMEM:NAME 'DUMPFIL' "
OUTPUT @Hp4155;":MMEM:NAME?"
ENTER @Hp4155;A$
```

See also

HCOPy:DESTination, MMEMory:DESTination

SCPI Commands
:MMEMory:STORe:SSHeet

:MMEMory:STORe:SSHeet

This command creates/stores the spreadsheet file (ASCII format) of the result data.

Before executing this command, do following:

- Enter :MMEM:DEST to specify the mass storage device.
- Enter :MMEM:STOR:SSH:DEL to specify the delimiter.
- Enter :MMEM:STOR:SSH:LIND to specify the data index.
- Enter :MMEM:STOR:SSH:SMARK to specify the string mark.
- Enter :MMEM:STOR:SSH:UNIT to specify whether to include units.

This command does not have query form.

Syntax

:MMEMory:STORe:SSHeet *file_name*

Parameter

Parameter	Type	Explanation
<i>file_name</i>	string	file name

Example

```
OUTPUT @Hp4155;":MMEM:STOR:SSH 'ASCData'"
```

:MMEMory:STORe:SSHeet:DELimiter

This command specifies the data delimiter (that separates result data) to use in the spreadsheet file that is created by :MMEMory:STORe:SSHeet command.

At *RST, this value is SPAC.

Syntax

:MMEMory:STORe:SSHeet:DELimiter SPACe | TAB | COMMa

Parameter

Parameter	Type	Explanation
SPACe	character	space
TAB	character	tab
COMMa	character	comma

Query response SPAC | TAB | COMM <newline><^END>

Example OUTPUT @Hp4155;":MMEM:STOR:SSH:DEL TAB"

:MMEMory:STORe:SSHeet:LINdex

This command specifies the range of measurement results to store in the spreadsheet file that is created by :MMEMory:STORe:SSHeet command.

This command changes the value of :HCOPy:LINdex.

At *RST, this value is (1,MAX).

Syntax :MMEMory:STORe:SSHeet:LINdex *first* | MINimum | MAXimum,
last | MINimum | MAXimum

Parameter

Parameter	Type	Explanation
<i>first</i>	numeric	first index number to output
<i>last</i>	numeric	last index number to output

Query response *first,last* <newline><^END>

The data type of *first* and *last* are NR1 response data.

Example OUTPUT @Hp4155;":MMEM:STOR:SSH:LIND 1,MAX"
OUTPUT @Hp4155;":MMEM:STOR:SSH:LIND?"
ENTER @Hp4155;A,B

See also :HCOPy:LINdex

SCPI Commands
:MMEMory:STORe:SSHeet:SMARK

:MMEMory:STORe:SSHeet:SMARK

This command specifies the string mark to use in the spreadsheet file that is created by :MMEMory:STORe:SSHeet command.

At *RST, this value is NONE.

Syntax :MMEMory:STORe:SSHeet:SMARK NONE | DQUote | SQUote

Parameter

Parameter	Type	Explanation
NONE	character	no string mark
DQUote	character	double quotes
SQUote	character	single quotes

Query response NONE | DQU | SQU <newline><^END>

Example OUTPUT @Hp4155; ":MMEM:STOR:SSH:SMARK DQU"

:MMEMory:STORe:SSHeet:UNIT

This command specifies whether to include units with result data in the spreadsheet file created by :MMEMory:STORe:SSHeet command.

At *RST, this value is OFF.

Syntax :MMEMory:STORe:SSHeet:UNIT OFF | ON | 0 | 1

Parameter

Parameter	Type	Explanation
OFF or 0	boolean	do not include units
ON or 1	boolean	include units

Query response 0 | 1 <newline><^END>

Example OUTPUT @Hp4155; ":MMEM:STOR:SSH:UNIT ON"

:MMEMory:STORe:STATe

This command stores the specified type of setup data to the mass storage device specified by the :MMEM:DEST command.

This command defines an event and thus has no *RST state or query form.

Execution Conditions

If you store a MAT file, enter the :PAGE:CHANnels:MATrix:CONTROL ON command before this command.

Syntax

:MMEMory:STORe:STATe *state_no*, *file_name* [, *msus*]

Parameter

Parameter	Type	Explanation
<i>state_no</i>	numeric	no meaning for 4155C/4156C. 0 is recommended.
<i>file_name</i>	string	file name must have extension (MES, STR, MAT, or CST) which specifies type of setup data.
<i>msus</i>	string	mass storage ('DISK' or 'MEMORY' is available)

The default mass storage is the device specified by the :MMEM:DEST command. To specify the device, set *msus* to 'DISK', or ignore *msus* parameter. You must specify an extension with the file name.

If you store the data in an internal memory, set *msus* to 'MEMORY'. The file name must be MEM1, MEM2, MEM3, or MEM4 with applicable file extension (MES, STR, or MAT).

Example

```
OUTPUT @Hp4155;":MMEM:STOR:STAT 0, 'CMOS.MES'"
```

```
OUTPUT @Hp4155;":MMEM:STOR:STAT 0, 'MEM1.MES', 'MEMORY'"
```

SCPI Commands
:MMEMory:STORe:TRACe

:MMEMory:STORe:TRACe

This command stores the measurement setup and results to the mass memory device specified by the :MMEM:DEST command.

This command does not have query form.

Syntax

:MMEMory:STORe:TRACe *label*, *file_name* [, *msus*]

Parameter

Parameter	Type	Explanation
<i>label</i>	character	DEFault only
<i>file_name</i>	string	file name
<i>msus</i>	string	mass storage ('DISK' or 'MEMORY' is available)

The default mass storage is the device set by the :MMEM:DEST command. To specify the device, set *msus* to 'DISK', or ignore *msus* parameter. The file name must have extension (DAT).

If you store the data in an internal memory, set *msus* to 'MEMORY'. The extension is optional, so file name can be MEM1, MEM2, MEM3, or MEM4 or with file extension (DAT).

Example

```
OUTPUT @Hp4155;":MMEM:STOR:TRAC DEF, 'CMOS.DAT'"
```

```
OUTPUT @Hp4155;":MMEM:STOR:TRAC DEF, 'MEM1.DAT', 'MEMORY'"
```

PAGE Subsystem

The PAGE subsystem commands are divided into several sections. Each command sets the fields of the "fill in the blank" user interface pages.

The hierarchy of the PAGE subsystem command is similar to the user interface page structure, except for the SCONtrol Subsystem.

The SCONtrol Subsystem controls the state of the 4155C/4156C, such as measurement, stress forcing, standby, and idle.

The SYSTEM group page functions are not implemented in the PAGE subsystem. These functions are controlled by other subsystems, such as MMEMory and HCOpy.

The following table shows the relation between the upper level keywords of the PAGE Subsystem and the user interface pages. Basically the first level keywords correspond to the *page group*, and the second level keywords correspond to the *page name*.

Command Hierarchy	User Interface Page Name
:PAGE	
:CHANnels	
[:CDEFinition]	CHANNELS: CHANNEL DEFINITION
:MATrix	CHANNELS: E5250A PROPERTIES
:UFUNction	CHANNELS: USER FUNCTION DEFINITION
:UVARiable	CHANNELS: USER VARIABLE DEFINITION
:DISPlay	
[:SETup]	DISPLAY: DISPLAY SETUP
:ANALysis	DISPLAY: ANALYSIS SETUP

SCPI Commands

Command Hierarchy	User Interface Page Name
:PAGE	
:GLIST	
[:GRAPHics]	GRAPH/LIST: GRAPHICS
:LIST	GRAPH/LIST: LIST
:KSweep	KNOB SWEEP
:MEASure	
[:SWEep]	MEASURE: SWEEP SETUP
:SAMPling	MEASURE: SAMPLING SETUP
:QSCV	MEASURE: QSCV SETUP MEASURE: QSCV MEASURE SETUP
:PGUSetup	MEASURE: PGU SETUP
:MSETup	MEASURE: MEASURE SETUP
:OSEquence	MEASURE: OUTPUT SEQUENCE
:SCONtrol	(state control)
:STress	
[:CDEFinition]	STRESS: CHANNEL DEFINITION
:SETup	STRESS: STRESS SETUP
:FORCe	STRESS: STRESS FORCE
:SYSTEM	for changing pages only, not setting.
:FILer	SYSTEM: FILER
:MISC	SYSTEM: MISCELLANEOUS
:CONFig	SYSTEM: CONFIGURATION
:CDIagnostic	SYSTEM: SELF-CALIBRATION/DIAGNOSTICS
:PRINT	SYSTEM: PRINT/PLOT SETUP
:COLor	SYSTEM: COLOR SETUP

:PAGE:CHAN Commands

:PAGE:CHAN commands set the CHANNELS pages.

Command	Parameter
:PAGE	
:CHANnels	
[:CDEFinition]	
:ALL	
:DISable	
:COMMeNt	<string>
:DEFault	
:GNDU	
:DISable	
:MODE?	
:VNAME	<name>
[:MENU]	
:MODE	SWEep SAMPling
:PGU (1 2)	
:DISable	
:MODE	V VPULse
:STANdby	0 1 OFF ON
:VNAME	<name>
:SMU (1 2 3 4 5 6)	
:DISable	
:FUNction	VAR1 VAR2 VARD CONStant
:INAME	<name>
:MODE	V I VPULse IPULse COMMon
:SRESistance	0 10K 100K 1M
:STANdby	0 1 OFF ON
:VNAME	<name>

SCPI Commands

Command	Parameter
:PAGE	
:CHANnels	
[:CDEFinition]	
:VMU(1 2)	
:DCHarge	0 1 OFF ON
:DISable	
:MODE	V DVOLt
:VNAME	<name>
:VSU(1 2)	
:DISable	
:FUNction	VAR1 VAR2 VARD CONStant
:MODE?	
:STANdby	0 1 OFF ON
:VNAME	<name>
:MATrix	
:CONNECTION	
:CONTROL	0 1 OFF ON
:GPIB:ADDRESS	<address>
:UFUNction	
:CATalog?	
:DEFine	<name>, <unit>, <definition>
:DELete	
[:NAME]	<name>
:ALL	
[:MENU]	
:UVARIABLE	
:CATalog?	
:DEFine	<name>, <unit>, <size>
:DELete	
[:NAME]	<name>
:ALL	
[:MENU]	

:PAGE:CHANnels[:CDEFinition]:ALL:DISable

This command deletes the settings of all units (SMU,VSU,VMU,PGU,GNDU).

This command does not have query form.

Syntax :PAGE:CHANnels [:CDEFinition] :ALL:DISable

Example OUTPUT @Hp4155;":PAGE:CHAN:ALL:DIS"

:PAGE:CHANnels[:CDEFinition]:COMMENT

This command sets the USER DEFINED COMMENT for the measurement group.

At *RST, a comment is not defined.

Syntax :PAGE:CHANnels [:CDEFinition] :COMMENT *comment*

Parameter

Parameter	Type	Explanation
<i>comment</i>	string	String of up to 58 characters.

Query response *comment* <newline><^END>

comment is string response data.

Example OUTPUT @Hp4155;":PAGE:CHAN:COMM'V-Icurve'"
OUTPUT @Hp4155;":PAGE:CHAN:COMM?"
ENTER @Hp4155;A\$

SCPI Commands

:PAGE:CHANnels[:CDEFinition]:DEFault

:PAGE:CHANnels[:CDEFinition]:DEFault

This command sets the measurement and stress setup to the same state as after *RST is executed.

This command does not affect the setup parameters of SYSTEM page group except the following:

PRINT SETUP all settings

COLOR SETUP PLOTTER PEN NO.

MISCELLANEOUS COMMAND SET

This command does not have query form.

Syntax :PAGE:CHANnels [:CDEFinition] :DEFault

Example OUTPUT @Hp4155; ":PAGE:CHAN:DEF"

:PAGE:CHANnels[:CDEFinition]:GNDU:DISable

This command deletes the settings of GNDU.

This command does not have query form.

Syntax :PAGE:CHANnels [:CDEFinition] :GNDU:DISable

Example OUTPUT @Hp4155; ":PAGE:CHAN:GNDU:DIS"

:PAGE:CHANnels[:CDEFinition]:GNDU:MODE?

This command returns the output MODE of GNDU.

This command has query form *only*.

Syntax :PAGE:CHANnels [:CDEFinition] :GNDU:MODE?

Query response COMM | DIS <newline><^END>

When the GNDU is not used, the response data may be DIS (DISable).

Example OUTPUT @Hp4155; ":PAGE:CHAN:GNDU:MODE?"
ENTER @Hp4155;A\$

:PAGE:CHANnels[:CDEFinition]:GNDU:VNAME

This command sets the VNAME of GNDU.

At *RST, this value is not defined.

Syntax

:PAGE:CHANnels [:CDEFinition] :GNDU:VNAME *name*

Parameter

Parameter	Type	Explanation
<i>name</i>	string	String of up to 6 alphanumeric characters. 1st character must be alphabet.

Query response

name <newline><^END>

name is string response data, but does not contain double quote characters at the beginning and end of the string.

Example

```
OUTPUT @Hp4155;":PAGE:CHAN:GNDU:VNAME 'VD'"
OUTPUT @Hp4155;":PAGE:CHAN:GNDU:VNAME?"
ENTER @Hp4155;A$
```

:PAGE:CHANnels[:CDEFinition][:MENU]

This command changes the present display page to "CHANNELS: CHANNEL DEFINITION" page.

This command does not have query form.

Syntax

:PAGE:CHANnels [:CDEFinition] [:MENU]

Example

```
OUTPUT @Hp4155;":PAGE:CHAN"
```

SCPI Commands
:PAGE:CHANnels[:CDEFinition]:MODE

:PAGE:CHANnels[:CDEFinition]:MODE

This command sets the MEASUREMENT MODE. This command also has a query form. At *RST, this value is set to SWEep.

Syntax :PAGE:CHANnels [:CDEFinition] :MODE SWEep | SAMPling | QSCV
:PAGE:CHANnels [:CDEFinition] :MODE?

Parameter

Parameter	Type	Explanation
SWEep	character	Sweep measurement mode
SAMPling	character	Sampling measurement mode
QSCV	character	Quasi-static CV measurement mode

Query response SWE | SAMP | QSCV <newline><^END>

Example
OUTPUT @Hp4155; ":PAGE:CHAN:MODE SWEep"
OUTPUT @Hp4155; ":PAGE:CHAN:MODE?"
ENTER @Hp4155; A\$

:PAGE:CHANnels[:CDEFinition]:PGU<n>:DISable

This command deletes the settings of PGU<n>.

<n> is required to specify PGU number. Valid PGU numbers are PGU1 through PGU2.

This command does not have query form.

Syntax :PAGE:CHANnels [:CDEFinition] :PGU<n>:DISable

Example OUTPUT @Hp4155; ":PAGE:CHAN:PGU1:DIS"

:PAGE:CHANnels[:CDEFinition]:PGU<n>:MODE

This command sets the output MODE of PGU<n>.

<n> is required to specify PGU number. Valid PGU numbers are PGU1 through PGU2.

At *RST, this value is not defined.

Syntax :PAGE:CHANnels [:CDEFinition] :PGU<n>:MODE V | VPULse

Parameter

Parameter	Type	Explanation
V	character	voltage output mode
VPULse	character	voltage pulse output mode

Query response V | VPUL | DIS <newline><^END>

If PGU is not used, the response data may be DIS (DISable).

Example

```
OUTPUT @Hp4155;":PAGE:CHAN:PGU1:MODE VPUL"
OUTPUT @Hp4155;":PAGE:CHAN:PGU1:MODE?"
ENTER @Hp4155;A$
```

:PAGE:CHANnels[:CDEFinition]:PGU<n>:STANdby

This command sets the standby (STBY) function of PGU<n>.

<n> is required to specify PGU number. Valid PGU numbers are PGU1 through PGU2.

At *RST, this value is OFF.

Syntax :PAGE:CHANnels [:CDEFinition] :PGU<n>:STANdby OFF | ON | 0 | 1

Parameter

Parameter	Type	Explanation
OFF or 0	boolean	standby function is OFF
ON or 1	boolean	standby function is ON

Query response 0 | 1 <newline><^END>

Example

```
OUTPUT @Hp4155;":PAGE:CHAN:PGU1:STANDBY ON"
OUTPUT @Hp4155;":PAGE:CHAN:PGU1:STANDBY?"
ENTER @Hp4155;A
```

SCPI Commands

:PAGE:CHANnels[:CDEFinition]:PGU<n>:VNAME

:PAGE:CHANnels[:CDEFinition]:PGU<n>:VNAME

This command sets the VNAME of PGU<n>.

<n> is required to specify PGU number. Valid PGU numbers are PGU1 through PGU2.

At *RST, this value is not defined.

Syntax

:PAGE:CHANnels [:CDEFinition] :PGU<n>:VNAME *name*

Parameter

Parameter	Type	Explanation
<i>name</i>	string	String of up to 6 alphanumeric characters. 1 st character must be alphabet.

Query response

name <newline><^END>

name is string response data, but does not contain double quote characters at the beginning and end of the string.

Example

```
OUTPUT @Hp4155;":PAGE:CHAN:PGU1:VNAME 'VD'"
OUTPUT @Hp4155;":PAGE:CHAN:PGU1:VNAME?"
ENTER @Hp4155;A$
```

:PAGE:CHANnels[:CDEFinition]:SMU<n>:DISable

This command deletes the settings of SMU<n>.

<n> is required to specify SMU number. Valid SMU numbers are SMU1 through SMU6, depending on the configuration.

This command does not have query form.

Syntax

:PAGE:CHANnels [:CDEFinition] :SMU<n>:DISable

Example

```
OUTPUT @Hp4155;":PAGE:CHAN:SMU1:DIS"
```

:PAGE:CHANnels[:CDEFinition]:SMU<n>:FUNCTION

This command sets the function (FCTN) of SMU<n>. This command also has a query form.

The value <n> is required to specify the SMU number. Valid SMU numbers are SMU1 through SMU6, depending on the configuration.

At *RST, this value is set to:

SMU	FUNCTION
SMU1	CONStant
SMU2	VAR2
SMU3	VAR1
SMU4	CONStant
SMU5 and SMU6	Not defined

Syntax

:PAGE:CHANnels [:CDEFinition] :SMU<n>:FUNCTION VAR1 | VAR2 | VARD | CONStant

:PAGE:CHANnels [:CDEFinition] :SMU<n>:FUNCTION?

Parameter

Parameter	Type	Explanation
VAR1	character	VAR1 function (available for sweep and QSCV)
VAR2	character	VAR2 function (sweep mode only)
VARD	character	VAR1' function (sweep mode only)
CONStant	character	Constant

Query response

VAR1 | VAR2 | VARD | CONS | DIS <newline><^END>

If an SMU is not used, the response data may be DIS (DISable).

Example

```
OUTPUT @Hp4155; ":PAGE:CHAN:SMU1:FUNC VAR1"
```

```
OUTPUT @Hp4155; ":PAGE:CHAN:SMU1:FUNC?"  
ENTER @Hp4155; A$
```

SCPI Commands

:PAGE:CHANnels[:CDEFinition]:SMU<n>:INAME

:PAGE:CHANnels[:CDEFinition]:SMU<n>:INAME

This command sets the INAME of SMU<n>.

<n> is required to specify SMU number. Valid SMU numbers are SMU1 through SMU6, depending on the configuration.

At *RST, this value is:

SMU	INAME
SMU1 through SMU4	I<n>
SMU5 and SMU6	not defined

Syntax

:PAGE:CHANnels [:CDEFinition] :SMU<n>:INAME *name*

Parameter

Parameter	Type	Explanation
<i>name</i>	string	String of up to 6 alphanumeric characters. 1 st character must be alphabet.

Query response

name <newline><^END>

name is string response data, but does not contain double quote characters at the beginning and end of the string.

Example

```
OUTPUT @Hp4155;":PAGE:CHAN:SMU1:INAME 'ID'"
OUTPUT @Hp4155;":PAGE:CHAN:SMU1:INAME?"
ENTER @Hp4155;A$
```

:PAGE:CHANnels[:CDEFinition]:SMU<n>:MODE

This command sets the output MODE of SMU<n>. This command also has a query form.

The value <n> is required to specify an SMU number. Valid SMU numbers are SMU1 through SMU6, depending on the configuration.

At *RST, this value is set to:

SMU	OUTPUT MODE
SMU1	COMMon
SMU2	I
SMU3 and SMU4	V
SMU5 and SMU6	Not defined.

Syntax

:PAGE:CHANnels [:CDEFinition] :SMU<n>:MODE V | I | VPULse | IPULse | COMMon

:PAGE:CHANnels [:CDEFinition] :SMU<n>:MODE?

Parameter

Parameter	Type	Explanation
V	character	Voltage output mode
I	character	Current output mode
VPULse	character	Voltage pulse output mode (sweep mode only)
IPULse	character	Current pulse output mode (sweep mode only)
COMMon	character	Common

For the quasi-static CV measurements, V is available for the VAR1 channel, and V and COMMON are available for the measurement channel.

Query response

V | I | VPUL | IPUL | COMM | DIS <newline><^END>

If an SMU is not used, the response data may be DIS (DISable).

Example

```
OUTPUT @Hp4155; ":PAGE:CHAN:SMU1:MODE V"
OUTPUT @Hp4155; ":PAGE:CHAN:SMU1:MODE?"
ENTER @Hp4155;A$
```

SCPI Commands

:PAGE:CHANnels[:CDEFinition]:SMU<n>:SRESistance

:PAGE:CHANnels[:CDEFinition]:SMU<n>:SRESistance

This command sets the SERIES RESISTANCE of SMU<n>.

<n> is required to specify SMU number. Valid SMU numbers are SMU1 through SMU6, depending on the configuration.

At *RST, this value is 0 OHM.

Syntax

:PAGE:CHANnels [:CDEFinition] :SMU<n>:SRESistance *resistance* | MINimum | MAXimum

Parameter

Parameter	Type	Explanation
<i>resistance</i>	numeric	0, 1E4, 1E5, or 1E6

You can use the suffix of OHM, KOHM, and MOHM.

Query response

resistance <newline><^END>

resistance is NR3 response data type.

Example

```
OUTPUT @Hp4155;":PAGE:CHAN:SMU1:SRES 1E4"
OUTPUT @Hp4155;":PAGE:CHAN:SMU1:SRES 10KOHM"
OUTPUT @Hp4155;":PAGE:CHAN:SMU1:SRES 1MOHM"
OUTPUT @Hp4155;":PAGE:CHAN:SMU1:SRES MAX"
OUTPUT @Hp4155;":PAGE:CHAN:SMU1:SRES?"
ENTER @Hp4155;A
OUTPUT @Hp4155;":PAGE:CHAN:SMU1:SRES? MAX"
ENTER @Hp4155;A
```

:PAGE:CHANnels[:CDEFinition]:SMU<n>:STANdby

This command sets the standby (STBY) function of SMU<n>.

<n> is required to specify SMU number. Valid SMU numbers are SMU1 through SMU6, depending on the configuration.

At *RST, standby function is OFF.

Syntax

:PAGE:CHANnels [:CDEFinition] :SMU<n>:STANdby OFF | ON | 0 | 1

Parameter

Parameter	Type	Explanation
OFF <i>or</i> 0	boolean	standby function is OFF
ON <i>or</i> 1	boolean	standby function is ON

Query response 0 | 1 <newline><^END>

Example
 OUTPUT @Hp4155;":PAGE:CHAN:SMU1:STANDBY ON"
 OUTPUT @Hp4155;":PAGE:CHAN:SMU1:STANDBY?"
 ENTER @Hp4155;A

:PAGE:CHANnels[:CDEFinition]:SMU<n>:VNAME

This command sets the VNAME of SMU<n>.

<n> is required to specify SMU number. Valid SMU numbers are SMU1 through SMU6, depending on the configuration.

At *RST, this value is:

SMU	VNAME
SMU1 through SMU4	V<n>
SMU5 and SMU6	not defined

Syntax :PAGE:CHANnels [:CDEFinition] :SMU<n>:VNAME *name*

Parameter

Parameter	Type	Explanation
<i>name</i>	string	String of up to 6 alphanumeric characters. 1 st character must be alphabet.

Query response *name* <newline><^END>

name is string response data, but does not contain double quote characters at the beginning and end of the string.

Example
 OUTPUT @Hp4155;":PAGE:CHAN:SMU1:VNAME 'VD'"
 OUTPUT @Hp4155;":PAGE:CHAN:SMU1:VNAME?"
 ENTER @Hp4155;A\$

SCPI Commands

:PAGE:CHANnels[:CDEFinition]:VMU<n>:DCHarge

:PAGE:CHANnels[:CDEFinition]:VMU<n>:DCHarge

This command connects, or disconnects, the VMU input discharge resistor used to prevent the VMU inputs from becoming charged when the inputs are opened. This command also has a query form.

At *RST, this value is ON.

Syntax

:PAGE:CHANnels [:CDEFinition] :VMU<n>:DCHarge OFF | ON | 0 | 1

:PAGE:CHANnels [:CDEFinition] :VMU<n>:DCHarge?

<n> must be 1 or 2.

Parameter

Parameter	Type	Explanation
OFF or 0	Boolean	Disconnects the discharge resistors from the VMU inputs.
ON or 1	Boolean	Connects the discharge resistors to the VMU inputs, and automatically breaks the connection only when in the measurement state.

When an auto-calibration is executed, the setting is not changed.

Query response

0 | 1 <newline><^END>

Example

```
OUTPUT @Hp4155;":PAGE:CHAN:VMU1:DCH ON"
```

The command above specifies VMU1, but it connects the discharge resistor to both the VMU1 and VMU2 inputs.

```
OUTPUT @Hp4155;":PAGE:CHAN:VMU1:DCH?"  
ENTER @Hp4155;A
```

:PAGE:CHANnels[:CDEFinition]:VMU<n>:DISable

This command deletes the settings of VMU<n>.

<n> is required to specify VMU number. Valid VMU numbers are VMU1 through VMU2.

This command does not have query form.

Syntax :PAGE:CHANnels [:CDEFinition] :VMU<n>:DISable

Example OUTPUT @Hp4155;":PAGE:CHAN:VMU1:DIS"

:PAGE:CHANnels[:CDEFinition]:VMU<n>:MODE

This command sets the MODE of VMU<n>.

<n> is required to specify VMU number. Valid VMU numbers are VMU1 through VMU2.

At *RST, this value is V.

Syntax :PAGE:CHANnels [:CDEFinition] :VMU<n>:MODE V | DVOLT

Parameter

Parameter	Type	Explanation
V	character	voltage measurement mode
DVOLT	character	differential voltage measurement mode

Query response V | DVOL | DIS <newline><<^END>

If VMU is not used, the response data may be DIS (DISable).

Example OUTPUT @Hp4155;":PAGE:CHAN:VMU1:MODE V"

OUTPUT @Hp4155;":PAGE:CHAN:VMU1:MODE?"
ENTER @Hp4155;A\$

SCPI Commands

:PAGE:CHANnels[:CDEFinition]:VMU<n>:VNAME

:PAGE:CHANnels[:CDEFinition]:VMU<n>:VNAME

This command sets the VNAME of VMU<n>.

<n> is required to specify VMU number. Valid VMU numbers are VMU1 through VMU2.

At *RST, this value is VMU<n>.

Syntax

:PAGE:CHANnels [:CDEFinition] :VMU<n>:VNAME *name*

Parameter

Parameter	Type	Explanation
<i>name</i>	string	String of up to 6 alphanumeric characters. 1 st character must be alphabet.

Query response

name <newline><^END>

name is the string response data, but does not contain double quote characters at the beginning and end of the string.

Example

```
OUTPUT @Hp4155;":PAGE:CHAN:VMU1:VNAME 'VD'"
OUTPUT @Hp4155;":PAGE:CHAN:VMU1:VNAME?"
ENTER @Hp4155;A$
```

:PAGE:CHANnels[:CDEFinition]:VSU<n>:DISable

This command deletes the settings of VSU<n>.

<n> is required to specify VSU number. Valid VSU numbers are VSU1 through VSU2.

This command does not have query form.

Syntax

:PAGE:CHANnels [:CDEFinition] :VSU<n>:DISable

Example

```
OUTPUT @Hp4155;":PAGE:CHAN:VSU1:DIS"
```

:PAGE:CHANnels[:CDEFinition]:VSU<n>:FUNCTION

This command sets the function (FCTN) of VSU<n>.

<n> is required to specify VSU number. Valid VSU numbers are VSU1 through VSU2.

At *RST, this value is CONStant.

Syntax

:PAGE:CHANnels [:CDEFinition] :VSU<n>:FUNCTION VAR1 | VAR2 | VARD | CONStant

Parameter

Parameter	Type	Explanation
VAR1	character	VAR1 function
VAR2	character	VAR2 function
VARD	character	VAR1' function
CONStant	character	constant

Query response

VAR1 | VAR2 | VARD | CONS | DIS <newline><^END>

If VSU is not used, the response data may be DIS (DISable).

Example

```
OUTPUT @Hp4155;":PAGE:CHAN:VSU:FUNC VAR1"
OUTPUT @Hp4155;":PAGE:CHAN:VSU:FUNC?"
ENTER @Hp4155;A$
```

SCPI Commands

:PAGE:CHANnels[:CDEFinition]:VSU<n>:MODE?

:PAGE:CHANnels[:CDEFinition]:VSU<n>:MODE?

This command returns the output MODE of VSU<n>.

<n> is required to specify VSU number. Valid VSU numbers are VSU1 through VSU2.

This command has query form *only*.

Syntax

:PAGE:CHANnels [:CDEFinition] :VSU<n>:MODE?

Query response

V | DIS <newline><^END>

When the specified VSU is not used, the response data may be DIS (DISable).

Example

```
OUTPUT @Hp4155;":PAGE:CHAN:VSU1:MODE?"  
ENTER @Hp4155;A$
```

:PAGE:CHANnels[:CDEFinition]:VSU<n>:STANdby

This command sets the standby (STBY) function of VSU<n>.

<n> is required to specify VSU number. Valid VSU numbers are VSU1 through VSU2.

At *RST, standby function is OFF.

Syntax

:PAGE:CHANnels [:CDEFinition] :VSU<n>:STANdby OFF | ON | 0 | 1

Parameter

Parameter	Type	Explanation
OFF <i>or</i> 0	boolean	standby function is OFF
ON <i>or</i> 1	boolean	standby function is ON

Query response

0 | 1 <newline><^END>

Example

```
OUTPUT @Hp4155;":PAGE:CHAN:VSU1:STANDBY ON"  
OUTPUT @Hp4155;":PAGE:CHAN:VSU1:STANDBY?"  
ENTER @Hp4155;A
```

:PAGE:CHANnels[:CDEFinition]:VSU<n>:VNAME

This command sets the VNAME of VSU<n>.

<n> is required to specify VSU number. Valid VSU numbers are VSU1 through VSU2.

At *RST, this value is VSU<n>.

Syntax :PAGE:CHANnels [:CDEFinition] :VSU<n>:VNAME *name*

Parameter

Parameter	Type	Explanation
<i>name</i>	string	String of up to 6 alphanumeric characters. 1 st character must be alphabet.

Query response *name* <newline><^END>

name is the string response data, but does not contain double quote characters at the beginning and end of the string.

Example
 OUTPUT @Hp4155;":PAGE:CHAN:VSU1:VNAME 'VD'"
 OUTPUT @Hp4155;":PAGE:CHAN:VSU1:VNAME?"
 ENTER @Hp4155;A\$

:PAGE:CHANnels:MATrix:CONNECTION

This command sends the matrix connection setup to the Agilent E5250A Low Leakage Switch Mainframe.

Execution Conditions This command is executable only on the built-in IBASIC controller.

Syntax :PAGE:CHANnels:MATrix:CONNECTION

Example
 OUTPUT @Hp4155;":PAGE:CHAN:MAT:GPIB:ADDRESS 20"
 OUTPUT @Hp4155;":PAGE:CHAN:MAT:CONTROL ON"
 OUTPUT @Hp4155;":MMEM:DEST INTERNAL"
 OUTPUT @Hp4155;":MMEM:LOAD:STAT 0,'SET1.MAT','DISK'"
 DISP "MODIFY E5250A SETUP. THEN PRESS Continue."
 PAUSE
 DISP ""
 OUTPUT @Hp4155;":PAGE:CHAN:MAT:CONN"

SCPI Commands
:PAGE:CHANnels:MATrix:CONTROL

:PAGE:CHANnels:MATrix:CONTROL

This command enables, or disables, remote control of the Agilent E5250A Low Leakage Switch Mainframe. This command also has a query form.

At *RST, this value is OFF.

Execution Conditions

This command is executable only on the built-in IBASIC controller.

Syntax

:PAGE:CHANnels:MATrix:CONTROL OFF | ON | 0 | 1

:PAGE:CHANnels:MATrix:CONTROL?

Parameter

Parameter	Type	Explanation
OFF or 0	Boolean	The 4155C/4156C cannot control Agilent E5250A.
ON or 1	Boolean	The 4155C/4156C can control Agilent E5250A.

Query response

0 | 1 <newline><^END>

Example

```
OUTPUT @Hp4155;":PAGE:CHAN:MAT:CONTROL 1"  
OUTPUT @Hp4155;":PAGE:CHAN:MAT:CONTROL?"  
ENTER @Hp4155;A
```

:PAGE:CHANnels:MATrix:GPIB:ADDRess

This command sets the GPIB address of the Agilent E5250A Low Leakage Switch Mainframe to be controlled from the 4155C/4156C. This command also has a query form.

At *RST, this value retains its previous value.

Syntax :PAGE:CHANnels:MATrix:GPIB:ADDRess *address*

:PAGE:CHANnels:MATrix:GPIB:ADDRess?

Parameter

Parameter	Type	Explanation
<i>address</i>	numeric	GPIB address of the Agilent E5250A. 0 to 30. Initial setting: 22.

Query response *address* <newline><^END>

address is NR1 response data type.

Example OUTPUT @Hp4155;":PAGE:CHAN:MAT:GPIB:ADDR 10"
OUTPUT @Hp4155;":PAGE:CHAN:MAT:GPIB:ADDR?"
ENTER @Hp4155;A

:PAGE:CHANnels:UFUNction:CATalog?

This query command returns the number of and a list of currently defined functions.

This command has query form *only*.

Syntax :PAGE:CHANnels:UFUNction:CATalog?

Query response *num_function* ,*function_list* <newline><^END>

num_function is a numeric value, which is the number of user defined functions. The data type is NR1 response data.

function_list is a list of the user function names separated by commas. The data type is string response data, but does not contain double quote characters at the beginning and end of the string.

Example OUTPUT @Hp4155;":PAGE:CHAN:UFUN:CAT?"
ENTER @Hp4155;A, B\$

SCPI Commands

:PAGE:CHANnels:UFUNction:DEFine

:PAGE:CHANnels:UFUNction:DEFine

This command defines the USER FUNCTION.

If the specified function name already exists, this command overwrites the old data with the newly defined data.

If the specified function name does not exist, the new name appears in the uppermost blank field on the CHANNELS:USER FUNCTION DEFINITION page.

A maximum of six user functions can be defined. If this limit is exceeded, Unable to define more than 6 User functions. error (-182) is generated.

At *RST, all defined functions are deleted.

Syntax

:PAGE:CHANnels:UFUNction:DEFine *name, unit, definition*

For query:

:PAGE:CHANnels:UFUNction:DEFine? *name*

Parameter

Parameter	Type	Explanation
<i>name</i>	string	String of up to 6 alphanumeric characters. 1st character must be alphabet.
<i>unit</i>	string	String of up to 6 alphanumeric characters. The null string is allowed.
<i>definition</i>	string	expression

Query response

unit, definition <newline><^END>

unit and *definition* are string response data, but do not contain double quote characters at the beginning and end.

Example

```
OUTPUT @Hp4155;":PAGE:CHAN:UFUN:DEF 'VTH','V','@L1X'"
OUTPUT @Hp4155;":PAGE:CHAN:UFUN:DEF? 'VTH'"
ENTER @Hp4155;A$
```

:PAGE:CHANnels:UFUNction:DELeTe:ALL

This command deletes all specified USER FUNCTIONS, and frees the associated data area.

This command does not have query form.

Syntax :PAGE:CHANnels:UFUN:DEL:ALL

Example OUTPUT @Hp4155;":PAGE:CHAN:UFUN:DEL:ALL"

:PAGE:CHANnels:UFUNction:DELeTe[:NAME]

This command deletes the specified USER FUNCTION, and frees the function name and its data area for use by another definition.

This command does not have query form.

Syntax :PAGE:CHANnels:UFUNction:DELeTe [:NAME] *name*

Parameter

Parameter	Type	Explanation
<i>name</i>	string	defined user function name

Example OUTPUT @Hp4155;":PAGE:CHAN:UFUN:DEL 'VD'"

SCPI Commands

:PAGE:CHANnels:UFUNction[:MENU]

:PAGE:CHANnels:UFUNction[:MENU]

This command changes the present display page to CHANNELS: USER FUNCTION DEFINITION page.

This command does not have query form.

Syntax :PAGE:CHANnels:UFUNction [:MENU]

Example OUTPUT @Hp4155;":PAGE:CHAN:UFUN"

:PAGE:CHANnels:UVARiable:CATalog?

This query command returns the number and list of currently defined user variables.

This command has query form *only*.

Syntax :PAGE:CHANnels:UVARiable:CATalog?

Query response *num_variable,variable_name_list* <newline><^END>

num_variable is NR1 response data.

variable_name_list is a list of the user variable names separated by commas. The data type is string response data, but does not contain double quote characters at beginning and end of the string.

Example OUTPUT @Hp4155;":PAGE:CHAN:UVAR:CAT?"
ENTER @Hp4155;A,B\$

:PAGE:CHANnels:UVARiable:DEFine

This command defines the name, size, and unit of a user variable. This command is the same as the :DATA | :TRACe:DEFINE command. To assign data to the user variable, you use the :DATA| :TRACe[:DATA] command.

If the specified user variable already exists, this command redefines the user variable with the new parameters.

A maximum of six user variables can be defined.

At *RST, no user variables are defined.

Syntax

:PAGE:CHANnels:UVARiable:DEFine *name,unit,size*

Parameter

Parameter	Type	Explanation
<i>name</i>	string	up to 6 alphanumeric characters. The 1st character must be an alphabet.
<i>unit</i>	string	up to 6 alphanumeric characters. The null string is allowed.
<i>size</i>	numeric	1 to 10001

Query response

unit,size <newline><^END>

unit is string response data, but does not contain double quote characters at beginning and end of the string.

size is NR1 response data.

Example

```
OUTPUT @Hp4155;":PAGE:CHAN:UVAR:DEF 'VTH','V',1001"
OUTPUT @Hp4155;":PAGE:CHAN:UVAR:DEF? 'VTH'"
ENTER @Hp4155;A$
```

SCPI Commands

:PAGE:CHANnels:UVARiable:DELeTe:ALL

:PAGE:CHANnels:UVARiable:DELeTe:ALL

This command deletes all defined user variables.

This command does not have query form.

Syntax

:PAGE:CHANnels:UVAR:DELeTe:ALL

Example

OUTPUT @Hp4155;":PAGE:CHAN:UVAR:DEL:ALL"

:PAGE:CHANnels:UVARiable:DELeTe[:NAME]

This command deletes the specified user variable.

This command does not have query form.

Syntax

:PAGE:CHANnels:UVARiable:DELeTe [:NAME] *name*

Parameter

Parameter	Type	Explanation
<i>name</i>	string	defined user variable name

Example

OUTPUT @Hp4155;":PAGE:CHAN:UVAR:DEL 'VD' "

:PAGE:CHANnels:UVARiable[:MENU]

This command changes the present display page to CHANNELS: USER VARIABLE DEFINITION page.

This command does not query form.

Syntax

:PAGE:CHANnels:UVARiable [:MENU]

Example

OUTPUT @Hp4155;":PAGE:CHAN:UVAR"

:PAGE:DISP Commands

:PAGE:DISP commands set the DISPLAY pages.

Command	Parameter
:PAGE	
:DISPlay	
:ANALysis	
:INTerpolate	0 1 OFF ON
:LINE (1 2)	
:GRADient	<expr>
:MODE	NORMAL GRADient TANGent REGREssion DISable
:POINT (1 2)	
:AFTer	<var_name>, <expr>
:STATe	0 1 OFF ON
:MODE	XY OPLot
:POSition	<var_name>, <expr>
:X	<expr>
:Y	<expr>
:TANGent	
:AFTer	<var_name>, <expr>
:STATe	0 1 OFF ON
:POSition	<var_name>, <expr>
:YAXis	Y1 Y2
:MARKer	
:AFTer	<var_name>, <expr>
:STATe	0 1 OFF ON
:DISable	
:POSition	<var_name>, <expr>
[:MENU]	

SCPI Commands

Command	Parameter
:PAGE	
:DISPlay	
[:SETup]	
:DRESOL	NORMal EXTend
:DVARIABLE	
[:SElect]	<var_name> {, <var_name>}
:DElete	
:ALL	
[:NAME]	<name>
:GRAPHics	
:GRID	0 1 OFF ON
:LPARam	0 1 OFF ON
:X	
:DElete	
:MAX	<numeric_value>
:MIN	<numeric_value>
:NAME	<var_name>
:SCALE	LINear LOGarithmic
:Y1	
:DElete	
:MAX	<numeric_value>
:MIN	<numeric_value>
:NAME	<var_name>
:SCALE	LINear LOGarithmic
:Y2	
:DElete	
:MAX	<numeric_value>
:MIN	<numeric_value>
:NAME	<var_name>
:SCALE	LINear LOGarithmic

Command	Parameter
:PAGE	
:DISPlay	
[:SETup]	
:LIST	
[:SElect]	<var_name> {,<var_name>}
:DElete	
:ALL	
[:NAME]	<name>
[:MENU]	
:MODE	GRAPhics LIST

SCPI Commands
:PAGE:DISPlay:ANALysis:INTerpolate

:PAGE:DISPlay:ANALysis:INTerpolate

This command selects whether interpolation mode of marker is on or off.

At *RST, this value is OFF.

Syntax :PAGE:DISPlay:ANALysis:INTerpolate OFF | ON | 0 | 1

Parameter

Parameter	Type	Explanation
OFF or 0	boolean	interpolation is off
ON or 1	boolean	interpolation is on

Query response 0 | 1 <newline><^END>

Example
OUTPUT @Hp4155;":PAGE:DISP:ANAL:INT ON"
OUTPUT @Hp4155;":PAGE:DISP:ANAL:INT?"
ENTER @Hp4155;A

:PAGE:DISPlay:ANALysis:LINE(1|2):ASElect

This command selects whether the Y axis is Y1 or Y2.

At *RST, this value is Y1.

Syntax :PAGE:DISPlay:ANALysis:LINE(1 | 2):ASElect Y1 | Y2

Parameter

Parameter	Type	Explanation
Y1	character	y axis is Y1
Y2	character	y axis is Y2

Query response Y1 | Y2 <newline><^END>

Example
OUTPUT @Hp4155;":PAGE:DISP:ANAL:LINE1:ASEL Y1"
OUTPUT @Hp4155;":PAGE:DISP:ANAL:LINE1:ASEL?"
ENTER @Hp4155;A\$

:PAGE:DISPlay:ANALysis:LINE(1|2):GRADient

This command sets the gradient value of LINE1 or LINE2.

If LINE (1 | 2) :MODE is not GRADient, this parameter is ignored.

At *RST, this value is undefined.

Syntax

:PAGE:DISPlay:ANALysis:LINE(1 | 2):GRADient *gradient*

Parameter

Parameter	Type	Explanation
<i>gradient</i>	string	expression for gradient value of line

Query response

gradient <newline><^END>

gradient is string response data, but does not contain double quote characters at the beginning and end of the string.

Example

```
OUTPUT @Hp4155;":PAGE:DISP:ANAL:LINE1:GRAD '2.0'"
```

```
OUTPUT @Hp4155;":PAGE:DISP:ANAL:LINE1:GRAD?"
```

```
ENTER @Hp4155;A$
```

SCPI Commands
:PAGE:DISPlay:ANALysis:LINE(1|2):MODE

:PAGE:DISPlay:ANALysis:LINE(1|2):MODE

This command selects the line mode.

At *RST, this value is NORMa1.

Syntax :PAGE:DISPlay:ANALysis:LINE(1 | 2):MODE NORMAL | GRADient | TANGent | REGReSSion | DISable

Parameter

Parameter	Type	Explanation
NORMal	character	normal mode (use :POINT1 and :POINT2)
GRADient	character	gradient mode (use :POINT1 and :GRADient)
TANGent	character	tangent mode (use :TANGent)
REGReSSion	character	regression mode (use :POINT1 and :POINT2)
DISable	character	line is disabled

Query response NORM | GRAD | TANG | REGR | DIS <newline><<^END>

Example
OUTPUT @Hp4155;":PAGE:DISP:ANAL:LINE1:MODE GRAD"
OUTPUT @Hp4155;":PAGE:DISP:ANAL:LINE1:MODE?"
ENTER @Hp4155;A\$

:PAGE:DISPlay:ANALysis:LINE(1|2):POINT(1|2):AFTer

This command specifies the start position (AFT: *var_name*, *expr*) to search for the point specified by (POS: *var_name*, *expr*).

If POINTs:MODE is XY (not OPLot), this parameter is ignored.

At *RST, this value is undefined.

Syntax :PAGE:DISPlay:ANALysis:LINE(1 | 2):POINT(1 | 2):AFTer *var_name*, *expr*

Parameter

Parameter	Type	Explanation
<i>var_name</i>	string	data variable name
<i>expr</i>	string	condition expression

:PAGE:DISPlay:ANALysis:LINE(1|2):POINT(1|2) :AFTer:STATe

Query response *var_name, expr* <newline><^END>

var_name and *expr* are string response data, but do not contain double quote characters at the beginning and end.

Example

```
OUTPUT @Hp4155;":PAGE:DISP:ANAL:LINE1:POIN1:AFT 'DGM','M
AX(DGM) '"
```

```
OUTPUT @Hp4155;":PAGE:DISP:ANAL:LINE1:POIN1:AFT?"
ENTER @Hp4155;A$
```

:PAGE:DISPlay:ANALysis:LINE(1|2):POINT(1|2) :AFTer:STATe

This command selects whether the start position of search is valid.

If **AFTER** *var_name, expr* is set, the **STATe** is automatically set to ON.

If **POINTs:MODE** is XY (not **OPLot**), this parameter is ignored.

At ***RST**, this value is OFF.

Syntax

:PAGE:DISPlay:ANALysis:LINE(1 | 2):POINT(1 | 2):AFTer:STATe OFF | ON | 0 | 1

Parameter

Parameter	Type	Explanation
OFF or 0	boolean	search entire area for the point
ON or 1	boolean	search for point only after the specified start position

Query response 0 | 1 <newline><^END>

Example

```
OUTPUT @Hp4155;":PAGE:DISP:ANAL:LINE1:POIN1:AFT:STAT ON"
```

```
OUTPUT @Hp4155;":PAGE:DISP:ANAL:LINE1:POIN1:AFT:STAT?"
ENTER @Hp4155;A
```

SCPI Commands

:PAGE:DISPlay:ANALysis:LINE(1|2):POINT(1|2):MODE

:PAGE:DISPlay:ANALysis:LINE(1|2):POINT(1|2):MODE

This command selects the point specification mode for line.

If LINE (1 | 2) :MODE is TANGent, then POINT (1 | 2) are not used.

If LINE (1 | 2) :MODE is GRADient, then POINT2 is not used.

At *RST, this value is XY.

Syntax

:PAGE:DISPlay:ANALysis:LINE(1 | 2):POINT(1 | 2):MODE XY | OPLot

Parameter

Parameter	Type	Explanation
XY	character	specify the X-Y coordinates directly
OPLot	character	specify by a condition expression

Query response

XY | OPL <newline><<^END>

Example

```
OUTPUT @Hp4155;":PAGE:DISP:ANAL:LINE1:POIN1:MODE XY"
OUTPUT @Hp4155;":PAGE:DISP:ANAL:LINE1:POIN1:MODE?"
ENTER @Hp4155;A$
```

:PAGE:DISPlay:ANALysis:LINE(1|2):POINT(1|2):POSITION

This command specifies the desired point by using a condition expression.

If POINT (1 | 2) :MODE is XY (not OPLot), this parameter is ignored.

At *RST, this value is undefined.

Syntax

:PAGE:DISPlay:ANALysis:LINE(1 | 2):POINT(1 | 2):POSITION *var_name*, *expr*

Parameter

Parameter	Type	Explanation
<i>var_name</i>	string	data variable name
<i>expr</i>	string	condition expression

:PAGE:DISPlay:ANALysis:LINE(1|2):POINT(1|2):X

Query response *var_name, expr* <newline><^END>

var_name and *expr* are string response data, but do not contain double quote characters at the beginning and end.

Example

```
OUTPUT @Hp4155;":PAGE:DISP:ANAL:LINE1:POIN1:POS 'DGM','M
AX(DGM)*0.01'"
```

```
OUTPUT @Hp4155;":PAGE:DISP:ANAL:LINE1:POIN1:POS?"
ENTER @Hp4155;A$
```

:PAGE:DISPlay:ANALysis:LINE(1|2):POINT(1|2):X

This command specifies the X coordinate of the desired point.

If POINT(1|2):MODE is OPLot (not XY), this parameter is ignored.

At *RST, this value is undefined.

Syntax:PAGE:DISPlay:ANALysis:LINE(1|2):POINT(1|2):X *x_expression***Parameter**

Parameter	Type	Explanation
<i>x_expression</i>	string	expression of the X coordinate point

Query response

x_value <newline><^END>

x_value is string response data, but do not contain double quote characters at beginning and end of the string.

Example

```
OUTPUT @Hp4155;":PAGE:DISP:ANAL:LINE1:POIN1:X '0.5'"
```

```
OUTPUT @Hp4155;":PAGE:DISP:ANAL:LINE1:POIN1:X?"
ENTER @Hp4155;A$
```

SCPI Commands

:PAGE:DISPlay:ANALysis:LINE(1|2):POINT(1|2):Y

:PAGE:DISPlay:ANALysis:LINE(1|2):POINT(1|2):Y

This command specifies the Y coordinate of the desired point.

If POINT(1|2):MODE is OPLot (not XY), this parameter is ignored.

At *RST, this value is undefined.

Syntax

:PAGE:DISPlay:ANALysis:LINE(1|2):POINT(1|2):Y *y_expression*

Parameter

Parameter	Type	Explanation
<i>y_expression</i>	string	expression of the Y coordinate point

Query response

y_value <newline><^END>

y_value is string response data, but does not contain double quote characters at the beginning and end of the string.

Example

```
OUTPUT @Hp4155;":PAGE:DISP:ANAL:LINE1:POIN1:Y '0.1'"
```

```
OUTPUT @Hp4155;":PAGE:DISP:ANAL:LINE1:POIN1:Y?"
```

```
ENTER @Hp4155;A$
```

:PAGE:DISPlay:ANALysis:LINE(1|2):TANGent:AFter

This command specifies the start position (TANG:AFT *var_name, expr*) to search for the point (TANG:POS *var_name, expr*) at which to draw the tangent line.

If LINE(1|2):MODE is not TANGent, this parameter is ignored.

At *RST, this value is undefined.

Syntax

:PAGE:DISPlay:ANALysis:LINE(1|2):TANGent:AFter *var_name, expr*

Parameter

Parameter	Type	Explanation
<i>var_name</i>	string	data variable name
<i>expr</i>	string	condition expression

Query response

var_name, expr <newline><^END>

:PAGE:DISPlay:ANALysis:LINE(1|2):TANGent:AFTer :STATe

var_name and *expr* are string response data, but do not contain double quote characters at the beginning and end.

Example

```
OUTPUT @Hp4155;":PAGE:DISP:ANAL:LINE1:TANG:AFT 'DGM','MAX(DGM)'"
```

```
OUTPUT @Hp4155;":PAGE:DISP:ANAL:LINE1:TANG:AFT?"
ENTER @Hp4155;A$
```

:PAGE:DISPlay:ANALysis:LINE(1|2):TANGent:AFTer :STATe

This command selects whether the start position of search is valid.

If TANG:AFTER *var_name*, *expr* is set, the STATe is automatically set to ON.

If LINE (1 | 2) :MODE is not TANGent, this parameter is ignored.

At *RST, this value is OFF.

Syntax

:PAGE:DISPlay:ANALysis:LINE(1|2):TANGent:AFTer:STATe OFF | ON | 0 | 1

Parameter

Parameter	Type	Explanation
OFF <i>or</i> 0	boolean	search entire area for the point
ON <i>or</i> 1	boolean	search for point only after the specified start position

Query response

0 | 1 <newline><<^END>

Example

```
OUTPUT @Hp4155;":PAGE:DISP:ANAL:LINE1:TANG:AFT:STAT ON"
```

```
OUTPUT @Hp4155;":PAGE:DISP:ANAL:LINE1:TANG:AFT:STAT?"
ENTER @Hp4155;A
```

SCPI Commands

:PAGE:DISPlay:ANALysis:LINE(1|2):TANGent :POSition

:PAGE:DISPlay:ANALysis:LINE(1|2):TANGent :POSition

This command specifies the point at which to draw a tangent line. The point is specified by a condition expression.

If `LINE (1 | 2) :MODE` is not `TANGent`, this parameter is ignored.

At `*RST`, this value is undefined.

Syntax

:PAGE:DISPlay:ANALysis:LINE(1 | 2):TANGent:POSition *var_name*, *expr*

Parameter

Parameter	Type	Explanation
<i>var_name</i>	string	data variable name
<i>expr</i>	string	condition expression

Query response

var_name, *expr* <newline><^END>

var_name and *expr* are string response data, but do not contain double quote characters at the beginning and end.

Example

```
OUTPUT @Hp4155;":PAGE:DISP:ANAL:LINE1:TANG:POS 'DGM','MAX(DGM)*0.01'"
```

```
OUTPUT @Hp4155;":PAGE:DISP:ANAL:LINE1:TANG:POS?"  
ENTER @Hp4155;A$
```

:PAGE:DISPlay:ANALysis:MARKer:AFTer

This command specifies the start position (`MARK:AFT var_name, expr`) to search for the marker position specified by (`MARK:POS var_name, expr`).

At `*RST`, this value is undefined.

Syntax

:PAGE:DISPlay:ANALysis:MARKer:AFTer *var_name*, *expr*

Parameter

Parameter	Type	Explanation
<i>var_name</i>	string	data variable name
<i>expr</i>	string	condition expression

Query response

var_name, expr <newline><^END>

var_name and *expr* are string response data, but do not contain double quote characters at the beginning and end.

Example

```
OUTPUT @Hp4155;":PAGE:DISP:ANAL:MARK:AFT 'DGM','MAX(DGM)
'"
OUTPUT @Hp4155;":PAGE:DISP:ANAL:MARK:AFT?"
ENTER @Hp4155;A$
```

:PAGE:DISPlay:ANALysis:MARKer:AFTer:STATe

This command selects whether the start position of search is valid.

If MARK:AFTER *var_name, expr* is set, the STATe is automatically set to ON.

At *RST, this value is OFF.

Syntax

:PAGE:DISPlay:ANALysis:MARKer:AFTer:STATe OFF | ON | 0 | 1

Parameter

Parameter	Type	Explanation
OFF or 0	boolean	search entire area for the point
ON or 1	boolean	search only after the specified start position

Query response

0 | 1 <newline><^END>

Example

```
OUTPUT @Hp4155;":PAGE:DISP:ANAL:MARK:AFT:STAT ON"
OUTPUT @Hp4155;":PAGE:DISP:ANAL:MARK:AFT:STAT?"
ENTER @Hp4155;A
```

SCPI Commands
:PAGE:DISPlay:ANALysis:MARKer:DISable

:PAGE:DISPlay:ANALysis:MARKer:DISable

This command clears the marker settings.

This command does not have query form.

Syntax :PAGE:DISPlay:ANALysis:MARKer:DISable

Example OUTPUT @Hp4155;":PAGE:DISP:ANAL:MARK:DIS"

:PAGE:DISPlay:ANALysis:MARKer:POSition

This command specifies the marker's position by using a condition expression.

At *RST, this value is undefined.

Syntax :PAGE:DISPlay:ANALysis:MARKer:POSition *var_name*, *expr*

Parameter

Parameter	Type	Explanation
<i>var_name</i>	string	data variable name
<i>expr</i>	string	condition expression

Query response *var_name*, *expr* <newline><^END>

var_name and *expr* are string response data, but do not contain double quote characters at the beginning and end.

Example OUTPUT @Hp4155;":PAGE:DISP:ANAL:MARK:POS 'DGM','MAX(DGM)
*0.01'"
OUTPUT @Hp4155;":PAGE:DISP:ANAL:MARK:POS?"
ENTER @Hp4155;A\$

:PAGE:DISPlay:ANALysis[:MENU]

This command changes the present display page to DISPLAY: ANALYSIS SETUP page.

This command does not have query form.

Syntax :PAGE:DISPlay:ANALysis [:MENU]

Example OUTPUT @Hp4155;":PAGE:DISP:ANAL"

:PAGE:DISPlay[:SETup]:DRESOL

This command changes the resolution of the measurement data displayed on the screen. This command also has a query form.

At *RST, this value is set to set to NORM.

Syntax :PAGE:DISPlay [:SETup] :DRESOL NORMal | EXTend

:PAGE:DISPlay:SETup:DRESOL?

Parameter

Parameter	Type	Explanation
NORMal	character	The resolution depends on the measurement resolution described in the specifications. For example, 1 fA resolution on the 10 pA range.
EXTend	character	The resolution is extended up to the full scale of the internal A/D converter. For example, 10 aA resolution on the 10 pA range.

Query response NORM | EXT <newline><^END>

Example OUTPUT @Hp4155;":PAGE:DISP:SET:DRESOL EXT"
OUTPUT @Hp4155;":PAGE:DISP:SET:DRESOL?"
ENTER @Hp4155;A\$

SCPI Commands

:PAGE:DISPlay[:SETup]:DVARiables:DELeTe:ALL

:PAGE:DISPlay[:SETup]:DVARiables:DELeTe:ALL

This command deletes all names that are displayed in the DATA VARIABLES fields of the DISPLAY: DISPLAY SETUP page. This is effective for both LIST and GRAPHICS display pages.

This command does not have query form.

Syntax

:PAGE:DISPlay [:SETup] :DVARiables:DELeTe:ALL

Example

```
OUTPUT @Hp4155;":PAGE:DISP:DVAR:DEL:ALL"
```

:PAGE:DISPlay[:SETup]:DVARiables:DELeTe[:NAME]

This command deletes the specified variable name from the DATA VARIABLES field of the DISPLAY: DISPLAY SETUP page.

This command does not have query form.

Syntax

:PAGE:DISPlay [:SETup] :DVARiables:DELeTe [:NAME] *var_name*

Parameter

Parameter	Type	Explanation
<i>var_name</i>	string	data variable name that appears in the DATA VARIABLES field of DISPLAY: DISPLAY SETUP page.

Example

```
OUTPUT @Hp4155;":PAGE:DISP:DVAR:DEL 'VD'"
```

:PAGE:DISPlay[:SETup]:DVARiables[:SElect]

This command selects the *additional* data variables for the graph or list. The coordinate values of these variables will be displayed according to the position of the marker.

If the specified variable name already exists, this command overwrites the old data with the newly defined data.

A maximum of two data variables can be used. If this limit is exceeded, Cannot define more than 2 displayed data vars. error (-184) is generated.

On the DISPLAY:DISPLAY SETUP page, this command fills the DATA VARIABLE blank fields from upper field to lower.

At *RST, no variable is selected.

Syntax

```
:PAGE:DISPlay [ :SETup ] :DVARiables [ :SElect ] var_name { ,var_name }
```

Parameter

Parameter	Type	Explanation
<i>var_name</i>	string	data variable name

Query response

```
var_name { ,var_name } <newline><^END>
```

Response is a list of data variables separated by commas, and is string response data, but does not contain double quote characters at the beginning and end of the string.

Example

```
OUTPUT @Hp4155;":PAGE:DISP:DVAR 'VD','VG'"
OUTPUT @Hp4155;":PAGE:DISP:DVAR?"
ENTER @Hp4155;A$
```

SCPI Commands

:PAGE:DISPlay[:SETup]:GRAPhics:GRID

:PAGE:DISPlay[:SETup]:GRAPhics:GRID

This command selects whether the grid of graph is on or off.

At *RST, this value is ON.

Syntax

:PAGE:DISPlay [:SETup] :GRAPhics:GRID OFF | ON | 0 | 1

Parameter

Parameter	Type	Explanation
OFF or 0	boolean	grid is off
ON or 1	boolean	grid is on

Query response

0 | 1 <newline><<^END>

Example

```
OUTPUT @Hp4155;":PAGE:DISP:GRAP:GRID ON"
OUTPUT @Hp4155;":PAGE:DISP:GRAP:GRID?"
ENTER @Hp4155;A
```

:PAGE:DISPlay[:SETup]:GRAPhics:LPARam

This command selects whether the line parameters (gradients and intercepts of lines) will be displayed on the graph.

At *RST, this value is ON.

Syntax

:PAGE:DISPLAY [:SETup] :GRAPhics:LPARam OFF | ON | 0 | 1

Parameter

Parameter	Type	Explanation
OFF or 0	boolean	line parameters are not displayed
ON or 1	boolean	line parameters are displayed

Query response

0 | 1 <newline><<^END>

Example

```
OUTPUT @Hp4155;":PAGE:DISP:GRAP:LPAR ON"
OUTPUT @Hp4155;":PAGE:DISP:GRAP:LPAR?"
ENTER @Hp4155;A
```

:PAGE:DISPlay[:SETup]:GRAPhics:X|:Y1|:Y2:DELeTe

:PAGE:DISPlay[:SETup]:GRAPhics:X|:Y1|:Y2:DELeTe

This command deletes the assignment of the X, Y1, or Y2 axis.

This command does not have query form.

Syntax

:PAGE:DISPlay [:SETup] :GRAPhics:X|:Y1|:Y2:DELeTe

Example

```
OUTPUT @Hp4155; ":PAGE:DISP:GRAP:X:DEL"
```

:PAGE:DISPlay[:SETup]:GRAPhics:X|:Y1|:Y2:MAX

This command sets the maximum value of X, Y1, or Y2 axis.

At *RST, this value is:

AXIS	variable name
X	1 V
Y1	100 mA
Y2	0

Syntax:PAGE:DISPlay [:SETup] :GRAPhics:X|:Y1|:Y2:MAX *maximum***Parameter**

Parameter	Type	Explanation
<i>maximum</i>	numeric	maximum value of X, Y1, or Y2 axis

Query response

```
maximum <newline><^END>
```

maximum is NR3 response data type.

Example

```
OUTPUT @Hp4155; ":PAGE:DISP:GRAP:X:MAX 10"
```

```
OUTPUT @Hp4155; ":PAGE:DISP:GRAP:X:MAX?"
ENTER @Hp4155;A
```

SCPI Commands

:PAGE:DISPlay[:SETup]:GRAPhics:X|:Y1|:Y2:MIN

:PAGE:DISPlay[:SETup]:GRAPhics:X|:Y1|:Y2:MIN

This command sets the minimum value of X, Y1, or Y2 axis.

At *RST, this value is:

AXIS	variable name
X	0 V
Y1	0 A
Y2	0

Syntax

:PAGE:DISPlay [:SETup] :GRAPhics:X|:Y1|:Y2:MIN *minimum*

Parameter

Parameter	Type	Explanation
<i>minimum</i>	numeric	minimum value of X, Y1, or Y2 axis

Query response

minimum <newline><^END>

minimum is NR3 response data type.

Example

```
OUTPUT @Hp4155;":PAGE:DISP:GRAP:X:MIN 0"
```

```
OUTPUT @Hp4155;":PAGE:DISP:GRAP:X:MIN?"
```

```
ENTER @Hp4155;A
```

:PAGE:DISPlay[:SETup]:GRAPhics:X|:Y1|:Y2:NAME

:PAGE:DISPlay[:SETup]:GRAPhics:X|:Y1|:Y2:NAME

This command selects the variable name of X, Y1, or Y2 axis.

At *RST, this value is:

AXIS	variable name
X	V3
Y1	I3
Y2	not defined

Syntax:PAGE:DISPlay [:SETup] :GRAPhics:X|:Y1|:Y2:NAME *var_name***Parameter**

Parameter	Type	Explanation
<i>var_name</i>	string	data variable name

Query response*var_name* <newline><^END>

var_name is string response data, but does not contain double quote characters at beginning and end of the string.

Example

```
OUTPUT @Hp4155;":PAGE:DISP:GRAP:X:NAME 'VD'"
OUTPUT @Hp4155;":PAGE:DISP:GRAP:X:NAME?"
ENTER @Hp4155;A$
```

:PAGE:DISPlay[:SETup]:GRAPhics:X|:Y1|:Y2:SCALE

This command selects whether the scale of X, Y1, or Y2 axis is LINear or LOGarithmic.

At *RST, this value is LINear for X and Y1, and not defined for Y2.

Syntax

:PAGE:DISPlay [:SETup] :GRAPhics:X|:Y1|:Y2:SCALE LINear | LOGarithmic

SCPI Commands

:PAGE:DISPlay[:SETup]:LIST:DELeTe:ALL

Parameter

Parameter	Type	Explanation
LINear	character	linear scale
LOGarithmic	character	logarithmic scale

Query response

LIN | LOG <newline><^END>

Example

```
OUTPUT @Hp4155;":PAGE:DISP:GRAP:X:SCAL LIN"  
OUTPUT @Hp4155;":PAGE:DISP:GRAP:X:SCAL?"  
ENTER @Hp4155;A$
```

:PAGE:DISPlay[:SETup]:LIST:DELeTe:ALL

This command deletes all the variable names from the LIST display. This does not delete the DATA VARIABLES fields, only the variable names in columns of LIST table.

This command does not have query form.

Syntax

:PAGE:DISPlay [:SETup] :LIST:DELeTe:ALL

Example

```
OUTPUT @Hp4155;":PAGE:DISP:LIST:DEL:ALL"
```

:PAGE:DISPlay[:SETup]:LIST:DELeTe[:NAME]

This command deletes the specified variable name from the LIST display.

This command does not have query form.

Syntax

:PAGE:DISPlay [:SETup] :LIST:DELeTe [:NAME] *var_name*

Parameter

Parameter	Type	Explanation
<i>var_name</i>	string	data variable name that appears in LIST table.

Example

```
OUTPUT @Hp4155;":PAGE:DISP:LIST:DEL 'VD'"
```

:PAGE:DISPlay[:SETup]:LIST[:SElect]

This command selects the variable names for LIST display.

You can display a maximum of eight variables in the list. If this limit is exceeded, Cannot define more than 8 data vars in lists. error (-183) is generated.

On the DISPLAY:DISPLAY SETUP page, this command fills the blank LIST fields in the specified order.

At *RST, no variable is selected.

Syntax :PAGE:DISPlay [:SETup] :LIST [:SElect] *var_name* { ,*var_name*}

Parameter

Parameter	Type	Explanation
<i>var_name</i>	string	data variable name

Query response *var_name* <newline><^END>

var_name is a list of variable names separated by commas, and is string response data, but does not contain double quote characters at the beginning and end of the string.

Example
OUTPUT @Hp4155;":PAGE:DISP:LIST 'VD','VG'
OUTPUT @Hp4155;":PAGE:DISP:LIST?"
ENTER @Hp4155;A\$

:PAGE:DISPlay[:SETup][:MENU]

This command changes the present display page to DISPLAY: DISPLAY SETUP.

This command does not have query form.

Syntax :PAGE:DISPlay [:SETup] [:MENU]

Example OUTPUT @Hp4155;":PAGE:DISP"

SCPI Commands
:PAGE:DISPlay[:SETup]:MODE

:PAGE:DISPlay[:SETup]:MODE

This command selects the display mode.

At *RST, this value is GRAPhics.

Syntax

:PAGE:DISPlay [:SETup] :MODE GRAPhics | LIST

Parameter

Parameter	Type	Explanation
GRAPhics	character	graphics display mode
LIST	character	list display mode

Query response

GRAP | LIST <newline><^END>

Example

```
OUTPUT @Hp4155;":PAGE:DISP:MODE GRAP"  
OUTPUT @Hp4155;":PAGE:DISP:MODE?"  
ENTER @Hp4155;A$
```

:PAGE:GLIS Commands

:PAGE:GLIS commands set the GRAPH/LIST pages.

Command	Parameter
:PAGE	
:GLIS	
[:GRAPhics]	
:AANalysis	
:ASElect	Y1 Y2
:CURSor	
:DIRect	
:X	<numeric_value>
:Y1	<numeric_value>
:Y2	<numeric_value>
[:STATe]	OFF SHORT LONG
:DISPlay	
:DVARiable	0 1 OFF ON
:GRID	0 1 OFF ON
:LPARam	0 1 OFF ON
:OVERlay	
:PLANE	0 1 2 3 4 OFF
:SINFO	0 1 OFF ON
:STOVERlay	
:INTerpolate	0 1 OFF ON
:LINE	
[:STATe]	OFF ON
:LSElect	NONE LINE1 LINE2 1 2
:MODE	NORMAL GRADient TANGent REGression
:GRADient	<numeric_value>
:CTMARker	
:SCURsorCPOint	

SCPI Commands

Command	Parameter
:PAGE	
:GLIST	
[:GRAPHics]	
:MARKer	
:DIRect	
:X	<numeric_value>
:Y1	<numeric_value>
:Y2	<numeric_value>
:LIMit	
:SKIP	
[:STATe]	0 1 OFF ON
[:MENU]	
:SCALing	
:AUTO	ONCE
:ZOOM	IN OUT
:CENTer	
:CANCel	
:CTMarker	
:LIST	
:ASElect	Y1 Y2
:MARKer	
:DIRect	INDEX <var_name>, <numeric_value>
:SKIP	
[:STATe]	0 1 OFF ON
[:MENU]	

:PAGE:GLIS[:GRAPhics]:AANalysis

This command redisplay the marker, cursors, and lines at the same positions as after auto-analysis was performed when the measurement finished. Auto-analysis is determined by DISPLAY: ANALYSIS SETUP, which corresponds to the :PAGE:DISPLAY:ANALysis subsystem.

This command does not have query form.

Syntax :PAGE:GLIS [:GRAPhics] :AANalysis

Example OUTPUT @Hp4155; ":PAGE:GLIS:AAN"

:PAGE:GLIS[:GRAPhics]:ASElect

This command selects whether the Y axis is Y1 or Y2.

At *RST, this value is Y1.

Syntax :PAGE:GLIS [:GRAPhics] :ASElect Y1 | Y2

Parameter

Parameter	Type	Explanation
Y1	character	y axis is Y1
Y2	character	y axis is Y2

Query response Y1 | Y2 <newline><^END>

Example OUTPUT @Hp4155; ":PAGE:GLIS:ASEL Y1"
OUTPUT @Hp4155; ":PAGE:GLIS:ASEL?"
ENTER @Hp4155;A\$

:PAGE:GLIS[:GRAPhics]:CURSor:DIRect:X[:Y1]:Y2

This command moves the cursor to the point that has the specified X, Y1, or Y2 value.

For the query response, the returned data is the X value of the present cursor position.

Variable name must be assigned to the specified axis by using :PAGE:DISP:GRAP:X | :Y1 | :Y2:NAME command.

SCPI Commands

:PAGE:GLIS[:GRAPhics]:CURSor[:STATe]

At *RST, this value is undefined.

Syntax

:PAGE:GLIS [:GRAPhics] :CURSor:DIRect:X|Y1|Y2 *value*

Parameter

Parameter	Type	Explanation
<i>value</i>	numeric	x, y1, or y2 coordinate value

Query response

value <newline><^END>

value is NR3 response data type.

Example

```
OUTPUT @Hp4155;":PAGE:GLIS:CURS:DIR:X 0.5"  
OUTPUT @Hp4155;":PAGE:GLIS:CURS:DIR:X?"  
ENTER @Hp4155;A
```

:PAGE:GLIS[:GRAPhics]:CURSor[:STATe]

This command sets the state of cursor.

At *RST, this value is OFF.

Syntax

:PAGE:GLIS [:GRAPhics] :CURSor [:STATe] OFF | SHORt | LONG

Parameter

Parameter	Type	Explanation
OFF	character	cursor is off
SHORt	character	short cursor is on
LONG	character	long cursor is on

Query response

OFF | SHORt | LONG <newline><^END>

Example

```
OUTPUT @Hp4155;":PAGE:GLIS:CURS LONG"  
OUTPUT @Hp4155;":PAGE:GLIS:CURS?"  
ENTER @Hp4155;A$
```

:PAGE:GLIST[:GRAPHics]:DISPlay:DVARiables

This command selects whether the variables specified in the DATA VARIABLES fields of the DISPLAY: DISPLAY SETUP will be displayed on the graph or list.

At *RST, this value is OFF.

Syntax :PAGE:GLIST [:GRAPHics] :DISPlay:DVARiables OFF | ON | 0 | 1

Parameter

Parameter	Type	Explanation
OFF or 0	boolean	variable list is off
ON or 1	boolean	variable list is on

Query response 0 | 1 <newline><<^END>

Example
 OUTPUT @Hp4155;":PAGE:GLIS:DISP:DVAR ON"
 OUTPUT @Hp4155;":PAGE:GLIS:DISP:DVAR?"
 ENTER @Hp4155;A

:PAGE:GLIST[:GRAPHics]:DISPlay:OVERlay:STOVerlay

This command forces the scale of the present measurement data to that of the overlay plane.

This command does not have query form.

Syntax :PAGE:GLIST [:GRAPHics] :DISPlay:OVERlay:STOVerlay

Example OUTPUT @Hp4155;":PAGE:GLIS:DISP:OVER:STOV"

SCPI Commands

:PAGE:GLIST[:GRAPHics]:DISPlay:OVERlay[:PLANE]

:PAGE:GLIST[:GRAPHics]:DISPlay:OVERlay[:PLANE]

This command overlays data in the selected internal memory onto the plotting area.

At *RST, this value is OFF.

Syntax

:PAGE:GLIST [:GRAPHics] :DISPlay:OVERlay [:PLANE] *memory_no* | OFF | 0

Parameter

Parameter	Type	Explanation
<i>memory_no</i>	numeric	1 to 4
OFF or 0	boolean	overlay plane is off

Query response

memory_no <newline><^END>

memory_no is NR1 response data.

Example

```
OUTPUT @Hp4155;":PAGE:GLIS:DISP:OVER 1"
```

```
OUTPUT @Hp4155;":PAGE:GLIS:DISP:OVER?"
```

```
ENTER @Hp4155;A
```

:PAGE:GLIST[:GRAPHics]:DISPlay:OVERlay:SINFo

This command sets the "show overlay information" mode to on or off.

At *RST, this value is OFF.

Syntax

:PAGE:GLIST [:GRAPHics] :DISPlay:OVERlay:SINFo OFF | ON | 0 | 1

Parameter

Parameter	Type	Explanation
OFF or 0	boolean	"show overlay information" mode is off
ON or 1	boolean	"show overlay information" mode is on

Query response

0 | 1 <newline><^END>

Example

```
OUTPUT @Hp4155;":PAGE:GLIS:DISP:OVER:SINF ON"
```

```
OUTPUT @Hp4155;":PAGE:GLIS:DISP:OVER:SINF?"
```

```
ENTER @Hp4155;A
```

:PAGE:GLIS[:GRAPHics]:DISPlay:GRID

This command selects whether the grid of graph axis is on or off.

At *RST, this value is ON.

Syntax :PAGE:GLIS [:GRAPHics] :DISPlay:GRID OFF | ON | 0 | 1

Parameter

Parameter	Type	Explanation
OFF or 0	boolean	grid is off
ON or 1	boolean	grid is on

Query response 0 | 1 <newline><<^END>

Example
 OUTPUT @Hp4155;":PAGE:GLIS:DISP:GRID ON"
 OUTPUT @Hp4155;":PAGE:GLIS:DISP:GRID?"
 ENTER @Hp4155;A

:PAGE:GLIS[:GRAPHics]:DISPlay:LPARam

This command selects whether the line parameters (gradient and intercepts of lines) are displayed on the graph.

At *RST, this value is ON.

Syntax :PAGE:GLIS [:GRAPHics] :DISPlay:LPARam OFF | ON | 0 | 1

Parameter

Parameter	Type	Explanation
OFF or 0	boolean	line parameters are not displayed
ON or 1	boolean	line parameters are displayed

Query response 0 | 1 <newline><<^END>

Example
 OUTPUT @Hp4155;":PAGE:GLIS:DISP:LPAR ON"
 OUTPUT @Hp4155;":PAGE:GLIS:DISP:LPAR?"
 ENTER @Hp4155;A

SCPI Commands
:PAGE:GLIST[:GRAPHics]:INTerpolate

:PAGE:GLIST[:GRAPHics]:INTerpolate

This command selects whether interpolation mode of marker is on or off.

At *RST, this value is OFF.

Syntax :PAGE:GLIST [:GRAPHics] :INTerpolate OFF | ON | 0 | 1

Parameter

Parameter	Type	Explanation
OFF or 0	boolean	interpolation is off
ON or 1	boolean	interpolation is on

Query response 0 | 1 <newline><^END>

Example
OUTPUT @Hp4155;":PAGE:GLIS:INT ON"
OUTPUT @Hp4155;":PAGE:GLIS:INT?"
ENTER @Hp4155;A

:PAGE:GLIST[:GRAPHics]:LINE:CTMarker

This command moves the cursor to the marker's position.

This command does not have query form.

Syntax :PAGE:GLIST [:GRAPHics] :LINE:CTMarker

Example OUTPUT @Hp4155;":PAGE:GLIS:LINE:CTM"

:PAGE:GLIS[:GRAPHics]:LINE:GRADient

This command sets the gradient value of line.

If `LINE:LSElect` is `NONE`, this command is ignored.

At `*RST`, this value is undefined.

Syntax

:PAGE:GLIS [:GRAPHics] :LINE:GRADient *gradient*

Parameter

Parameter	Type	Explanation
<i>gradient</i>	numeric	gradient value of line

Query response

gradient <newline><^END>

gradient is NR3 response data type.

Example

OUTPUT @Hp4155;":PAGE:GLIS:LINE:GRAD 1.5"

OUTPUT @Hp4155;":PAGE:GLIS:LINE:GRAD?"

ENTER @Hp4155;A

:PAGE:GLIS[:GRAPHics]:LINE:LSElect

This command selects the line to operate on.

At `*RST`, this value is `NONE`.

Syntax

:PAGE:GLIS [:GRAPHics] :LINE:LSElect LINE1 | LINE2 | NONE |
line_number | MINimum | MAXimum

Parameter

Parameter	Type	Explanation
LINE1	character	line 1 is selected
LINE2	character	line 2 is selected
NONE	character	no lines are selected
<i>line_number</i>	numeric	1 or 2

SCPI Commands
:PAGE:GLIST[:GRAPhics]:LINE:MODE

Query response *line_number* <newline><^END>

Example
OUTPUT @Hp4155;":PAGE:GLIS:LINE:LSEL 1"
OUTPUT @Hp4155;":PAGE:GLIS:LINE:LSEL?"
ENTER @Hp4155;A

:PAGE:GLIST[:GRAPhics]:LINE:MODE

This command selects the line mode.

Although this value is not defined at *RST, if you select the line to operate on by using :PAGE:GLIST[:GRAPhics]:LINE:LSElect, this value is set to NORM.

Syntax :PAGE:GLIST [:GRAPhics] :LINE:MODE NORMal | GRADient | TANGent | REGReasion

Parameter

Parameter	Type	Explanation
NORMal	character	normal mode
GRADient	character	gradient mode
TANGent	character	tangent mode
REGReasion	character	regression mode

Query response NORM | GRAD | TANG | REGR <newline><^END>

Example
OUTPUT @Hp4155;":PAGE:GLIS:LINE:MODE GRAD"
OUTPUT @Hp4155;":PAGE:GLIS:LINE:MODE?"
ENTER @Hp4155;A\$

:PAGE:GLIST[:GRAPhics]:LINE:SCURsor

This command toggles which cursor you want to operate on.

This command does not have query form.

Syntax :PAGE:GLIST [:GRAPhics] :LINE:SCURsor

Example
OUTPUT @Hp4155;":PAGE:GLIS:LINE:SCUR"

:PAGE:GLIS[:GRAPhics]:LINE[:STATe]

This command selects the state of line.

At *RST, this value is not defined.

Syntax

:PAGE:GLIS [:GRAPhics] :LINE [:STATe] OFF | ON

Parameter

Parameter	Type	Explanation
OFF	character	line is not displayed
ON	character	line is displayed, and can be operated on

Query response

OFF | ON <newline><^END>

Example

```
OUTPUT @Hp4155;":PAGE:GLIS:LINE ON"
OUTPUT @Hp4155;":PAGE:GLIS:LINE?"
ENTER @Hp4155;A$
```

:PAGE:GLIS[:GRAPhics]:MARKer:DIRect:X|:Y1|:Y2

This command moves the marker to the point that has the specified X, Y1, or Y2 value.

For the query response, the returned data is the X, Y1, or Y2 value of the present marker position.

Variable name must be assigned to the specified axis by using
 :PAGE:DISP:GRAP:X|:Y1|:Y2:NAME command.

At *RST, this value is undefined.

Syntax

:PAGE:GLIS [:GRAPhics] :MARKer:DIRect:X|Y1|Y2 *value* | MINimum | MAXimum

Parameter

Parameter	Type	Explanation
<i>value</i>	numeric	x, y1, or y2 coordinate value

Query response

value <newline><^END>

SCPI Commands

:PAGE:GLIS[:GRAPhics]:MARKer:LIMit

value is NR3 response data type.

Example

```
OUTPUT @Hp4155;":PAGE:GLIS:MARK:DIR:X 0.5"  
OUTPUT @Hp4155;":PAGE:GLIS:MARK:DIR:X?"  
ENTER @Hp4155;A
```

:PAGE:GLIS[:GRAPhics]:MARKer:LIMit

This command moves the marker to the minimum or maximum Y axis point of curve.

The search direction is from present to last measurement point, then from first to present measurement point.

This command does not have query form.

Syntax

:PAGE:GLIS [:GRAPhics] :MARKer:LIMit

Example

```
OUTPUT @Hp4155;":PAGE:GLIS:MARK:LIM"
```

:PAGE:GLIS[:GRAPhics]:MARKer:SKIP

This command skips the marker to the next measurement curve that was added by VAR2 variable or APPEND data.

This command does not have query form.

Syntax

:PAGE:GLIS [:GRAPhics] :MARKer:SKIP

Example

```
OUTPUT @Hp4155;":PAGE:GLIS:MARK:SKIP"
```

:PAGE:GLIS[:GRAPHics]:MARKer[:STATe]

This command selects whether the marker is on or off.

At *RST, this value is OFF.

Syntax :PAGE:GLIS [:GRAPHics] :MARKer [:STATe] OFF | ON | 0 | 1

Parameter

Parameter	Type	Explanation
OFF or 0	boolean	marker is off
ON or 1	boolean	marker is on

Query response 0 | 1 <newline><<^END>

Example
OUTPUT @Hp4155;":PAGE:GLIS:MARK ON"
OUTPUT @Hp4155;":PAGE:GLIS:MARK?"
ENTER @Hp4155;A

:PAGE:GLIS[:GRAPHics][:MENU]

This command changes the present display page to GRAPH/LIST: GRAPHICS.

This command does not have query form.

Syntax :PAGE:GLIS [:GRAPHics] [:MENU]

Example OUTPUT @Hp4155;":PAGE:GLIS"

:PAGE:GLIS[:GRAPHics]:SCALing:AUTO

This command redraws the present graphic display with appropriate scale to plot the data in the plotting area.

This command does not have query form.

Syntax :PAGE:GLIS [:GRAPHics] :SCALing:AUTO ONCE

Example OUTPUT @Hp4155;":PAGE:GLIS:SCAL:AUTO ONCE"

SCPI Commands
:PAGE:GLIST[:GRAPHics]:SCALing:CANCel

:PAGE:GLIST[:GRAPHics]:SCALing:CANCel

This command redraws the plotting area with the "original settings".

"Original settings" means the most recent settings of the DISPLAY: DISPLAY SETUP page or RE-SETUP GRAPH secondary softkey.

This command does not have query form.

Syntax :PAGE:GLIST [:GRAPHics] :SCALing:CANCel

Example OUTPUT @Hp4155; ":PAGE:GLIS:SCAL:CANc"

:PAGE:GLIST[:GRAPHics]:SCALing:CENTer

This command redraws the graphic display so that it is centered around the present cursor position.

This command does not have query form.

Syntax :PAGE:GLIST [:GRAPHics] :SCALing:CENTer

Example OUTPUT @Hp4155; ":PAGE:GLIS:SCAL:CENt"

:PAGE:GLIST[:GRAPHics]:SCALing:CTMarker

This command moves the cursor to the marker's position.

This command does not have query form.

Syntax :PAGE:GLIST [:GRAPHics] :SCALing:CTMarker

Example OUTPUT @Hp4155; ":PAGE:GLIS:SCAL:CTM"

:PAGE:GLIST[:GRAPhics]:SCALing:ZOOM

This command zooms the graphic display around the present cursor position.

This command does not have query form.

Syntax :PAGE:GLIST [:GRAPhics] :SCALing:ZOOM IN | OUT

Parameter

Parameter	Type	Explanation
IN	character	zoom in
OUT	character	zoom out

Example OUTPUT @Hp4155;":PAGE:GLIS:SCAL:ZOOM IN"

:PAGE:GLIST:LIST:ASElect

This command selects whether the Y axis of GRAPHICS page is Y1 or Y2 and changes the setting by :PAGE:GLIST[:GRAPhics]:ASElect.

You use this command when you would like to assign data variables, which uses line parameters of graphics, on list.

At *RST, this value is Y1.

Syntax :PAGE:GLIST:LIST:ASElect Y1 | Y2

Parameter

Parameter	Type	Explanation
Y1	character	y axis is Y1
Y2	character	y axis is Y2

Query response Y1 | Y2 <newline><^END>

Example OUTPUT @Hp4155;":PAGE:GLIST:LIST:ASEL Y1"
OUTPUT @Hp4155;":PAGE:GLIST:LIST:ASEL?"
ENTER @Hp4155;A\$

SCPI Commands
:PAGE:GLIST:LIST:MARKer:DIRect

:PAGE:GLIST:LIST:MARKer:DIRect

This command moves the marker to the variable value that is closest to the specified value.

For the query response, the returned data is the value at the present marker position.

At *RST, this value is undefined.

Syntax

:PAGE:GLIST:LIST:MARKer:DIRect *var_name* | INDeX,
value | MINimum | MAXimum

Syntax of the query is as follows:

:PAGE:GLIST:LIST:MARKer:DIRect? *var_name*|INDeX{,MINimum|MAXimum}

Parameter

Parameter	Type	Explanation
<i>var_name</i>	string	name of variable that is in LIST column
INDeX	character	index field
<i>value</i>	numeric	variable value or index number

Query response

value <newline><^END>

value is NR3 response data.

Example

```
OUTPUT @Hp4155;":PAGE:GLIST:LIST:MARK:DIR 'VD',0.5"  
OUTPUT @Hp4155;":PAGE:GLIST:LIST:MARK:DIR 'VD',MAX"  
OUTPUT @Hp4155;":PAGE:GLIST:LIST:MARK:DIR? 'VD'  
ENTER @Hp4155;B  
OUTPUT @Hp4155;":PAGE:GLIST:LIST:MARK:DIR? 'VD',MAX"  
ENTER @Hp4155;B
```

:PAGE:GLIST:LIST:MARKer:SKIP

This command skips the marker to the next VAR2 value or to the next appended data.

This command does not have query form.

Syntax :PAGE:GLIST:LIST:MARKer:SKIP

Example OUTPUT @Hp4155;":PAGE:GLIST:LIST:MARK:SKIP"

:PAGE:GLIST:LIST:MARKer[:STATe]

This command selects whether the marker is on or off.

At *RST, this value is OFF.

Syntax :PAGE:GLIST:LIST:MARKer [:STATe] OFF | ON | 0 | 1

Parameter

Parameter	Type	Explanation
OFF or 0	boolean	marker is off
ON or 1	boolean	marker is on

Query response 0 | 1 <newline><<^END>

Example OUTPUT @Hp4155;":PAGE:GLIST:LIST:MARK ON"
OUTPUT @Hp4155;":PAGE:GLIST:LIST:MARK?"
ENTER @Hp4155;A

:PAGE:GLIST:LIST[:MENU]

This command changes the present display page to GRAPH/LIST: LIST page.

This command does not have query form.

Syntax :PAGE:GLIST:LIST [:MENU]

Example OUTPUT @Hp4155;":PAGE:GLIS:LIST"

:PAGE:KSW Commands

:PAGE:KSW commands set the KNOB SWEEP page. These commands are not available when the 4155C/4156C screen is set to the update disable state by :DISP OFF (or 0) command. To use :PAGE:KSW commands, enter :DISP ON (or 1) command.

Command	Parameter
:PAGE	
:KSWEEP	
:CURSOR	
:X	<numeric_value>
:Y	<numeric_value>
:DISPLAY	
:DIRECTION	
:X	NORMAL REVERSE
:Y	NORMAL REVERSE
:GRID	0 1 OFF ON
:REGION	
:X	POSITIVE NEGATIVE BIPOLAR
:Y	POSITIVE NEGATIVE BIPOLAR
[:MENU]	
:SCOPY	
:VAR1	
:EXTENT	<numeric_value>
:MODE	SINGLE DOUBLE
:POLARITY	POSITIVE NEGATIVE BIPOLAR
:POINTS	<numeric_value>
:RANGE	<numeric_value>
:STIME	<numeric_value>
:Y	<var_name>

:PAGE:KSWeep:CURSor:X

This command positions the cursor at the specified X coordinate. This command does not affect the Y coordinate of the cursor.

At *RST, the cursor is located at the center of the graph.

Syntax

:PAGE:KSWeep:CURSor:X *x_position* | MINimum | MAXimum

Parameter

Parameter	Type	Explanation
<i>x_position</i>	numeric	desired X coordinate of cursor

Query response

x_position <newline><^END>

x_position is NR3 response data.

Example

```
OUTPUT @Hp4155;":PAGE:KSW:CURS:X 1.35"
```

```
OUTPUT @Hp4155;":PAGE:KSW:CURS:X MAX"
```

```
OUTPUT @Hp4155;":PAGE:KSW:CURS:X?"
```

```
ENTER @Hp4155;A
```

```
OUTPUT @Hp4155;":PAGE:KSW:CURS:X? MIN"
```

```
ENTER @Hp4155;A
```

:PAGE:KSWeep:CURSor:Y

This command positions the cursor at the specified Y coordinate. This command does not affect the X coordinate of the cursor.

At *RST, the cursor is located at the center of the graph.

Syntax

:PAGE:KSWeep:CURSor:Y *y_position* | MINimum | MAXimum

Parameter

Parameter	Type	Explanation
<i>y_position</i>	numeric	desired Y coordinate of cursor

Query response

y_position <newline><^END>

y_position is NR3 response data type.

SCPI Commands

:PAGE:KSW:DISPlay:DIRection:X

Example

```
OUTPUT @Hp4155;":PAGE:KSW:CURS:Y 1.35"  
OUTPUT @Hp4155;":PAGE:KSW:CURS:Y MAX"  
OUTPUT @Hp4155;":PAGE:KSW:CURS:Y?"  
ENTER @Hp4155;A  
OUTPUT @Hp4155;":PAGE:KSW:CURS:Y? MIN"  
ENTER @Hp4155;A
```

:PAGE:KSW:DISPlay:DIRection:X

This command sets the display direction of the X axis for knob sweep.

At *RST, this value is NORMal.

Syntax

:PAGE:KSW:DISPlay:DIRection:X NORMal | REVerse

Parameter

Parameter	Type	Explanation
NORMal	character	Leftmost point on X axis is minimum value.
REVerse	character	Rightmost point on X axis is minimum value.

Query response

NORM | REV <newline><^END>

Example

```
OUTPUT @Hp4155;":PAGE:KSW:DISP:DIR:X NORM"  
OUTPUT @Hp4155;":PAGE:KSW:DISP:DIR:X?"  
ENTER @Hp4155;A$
```

:PAGE:KSW:DISPlay:DIRection:Y

This command sets the display direction of the Y axis for knob sweep.

At *RST, this value is NORMal.

Syntax :PAGE:KSW:DISPlay:DIRection:Y NORMAL | REVerse

Parameter

Parameter	Type	Explanation
NORMal	character	Lowermost point on Y axis is minimum value.
REVerse	character	Uppermost point on Y axis is minimum value.

Query response NORM | REV <newline><^END>

Example
 OUTPUT @Hp4155;":PAGE:KSW:DISP:DIR:Y NORM"
 OUTPUT @Hp4155;":PAGE:KSW:DISP:DIR:Y?"
 ENTER @Hp4155;A\$

:PAGE:KSW:DISPlay:GRID

This command selects whether the grid of graph is on or off for knob sweep.

At *RST, this value is ON.

Syntax :PAGE:KSW:DISPlay:GRID OFF | ON | 0 | 1

Parameter

Parameter	Type	Explanation
OFF or 0	boolean	grid is off
ON or 1	boolean	grid is on

Query response 0 | 1 <newline><^END>

Example
 OUTPUT @Hp4155;":PAGE:KSW:DISP:GRID ON"
 OUTPUT @Hp4155;":PAGE:KSW:DISP:GRID?"
 ENTER @Hp4155;A

SCPI Commands
:PAGE:KSWEEP:DISPLAY:REGION:X

:PAGE:KSWEEP:DISPLAY:REGION:X

This command sets the display region of X axis for knob sweep.

At *RST, this value is POSITIVE.

Syntax :PAGE:KSWEEP:DISPLAY:REGION:X POSITIVE | NEGATIVE | BIPOLAR

Parameter

Parameter	Type	Explanation
POSITIVE	character	display positive X region
NEGATIVE	character	display negative X region
BIPOLAR	character	display positive and negative X region

Query response POS | NEG | BIP <newline><^END>

Example
OUTPUT @Hp4155;":PAGE:KSW:DISP:REG:X POS"
OUTPUT @Hp4155;":PAGE:KSW:DISP:REG:X?"
ENTER @Hp4155;A\$

:PAGE:KSWEEP:DISPLAY:REGION:Y

This command sets the display region of Y axis for knob sweep.

At *RST, this value is POSITIVE.

Syntax :PAGE:KSWEEP:DISPLAY:REGION:Y POSITIVE | NEGATIVE | BIPOLAR

Parameter

Parameter	Type	Explanation
POSITIVE	character	display positive Y region
NEGATIVE	character	display negative Y region
BIPOLAR	character	display positive and negative Y region

Query response POS | NEG | BIP <newline><^END>

Example
OUTPUT @Hp4155;":PAGE:KSW:DISP:REG:Y POS"
OUTPUT @Hp4155;":PAGE:KSW:DISP:REG:Y?"
ENTER @Hp4155;A\$

:PAGE:KSweep[:MENU]

This command changes the present display page to KNOB SWEEP page.

This command does not have query form.

Syntax :PAGE:KSweep [:MENU]

Example OUTPUT @Hp4155; ":PAGE:KSW"

:PAGE:KSweep:SCOPY

This command copies the sweep and graphic display settings of KNOB SWEEP page to the corresponding parameters of normal sweep.

This command does not have query form.

Syntax :PAGE:KSweep:SCOPY

Example OUTPUT @Hp4155; ":PAGE:KSW:SCOP"

:PAGE:KSweep:VAR1:EXTent

This command adjusts the sweep extent of the knob sweep measurement. This parameter is multiplied times the VAR1 range setting to determine the knob sweep range. For example, if the parameter of this command is set to 0.7, and the VAR1 range is set to 2 V, then VAR1 is swept from 0 to 1.4 V.

At *RST, this value is 0.

Syntax :PAGE:KSweep:VAR1:EXTent *extent*

Parameter

Parameter	Type	Explanation
<i>extent</i>	numeric	0 to 1

Negative value is not allowed. Output polarity is determined by the :PAGE:KSweep:VAR1:POLarity command.

Query response *extent* <newline><^END>

extent is NR3 response data type.

SCPI Commands
:PAGE:KSW:VAR1:MODE

Example

```
OUTPUT @Hp4155;":PAGE:KSW:VAR1:EXT 0.1"  
OUTPUT @Hp4155;":PAGE:KSW:VAR1:EXT?"  
ENTER @Hp4155;A
```

:PAGE:KSW:VAR1:MODE

This command sets the SWEEP MODE of VAR1 for knob sweep measurement.
At *RST, this value is SINGLe.

Syntax

:PAGE:KSW:VAR1:MODE SINGle | DOUBle

Parameter

Parameter	Type	Explanation
SINGle	character	single stair sweep
DOUBle	character	double stair sweep

Query response

SING | DOUB <newline><^END>

Example

```
OUTPUT @Hp4155;":PAGE:KSW:VAR1:MODE SING"  
OUTPUT @Hp4155;":PAGE:KSW:VAR1:MODE?"  
ENTER @Hp4155;A$
```

:PAGE:KSW:VAR1:POINts

This command sets the number of steps for VAR1 of knob sweep measurement.

At *RST, this value is 101.

Syntax :PAGE:KSW:VAR1:POINts *points* | MINimum | MAXimum

Parameter

Parameter	Type	Explanation
<i>points</i>	numeric	1 to 1001

Query response *points* <newline><^END>

points is NR1 response data type.

Example

```
OUTPUT @Hp4155;":PAGE:KSW:VAR1:POIN 101"
OUTPUT @Hp4155;":PAGE:KSW:VAR1:POIN MAX"
OUTPUT @Hp4155;":PAGE:KSW:VAR1:POIN?"
ENTER @Hp4155;A
OUTPUT @Hp4155;":PAGE:KSW:VAR1:POIN?MAX"
ENTER @Hp4155;A
```

SCPI Commands
:PAGE:KSWEEP:VAR1:POLARITY

:PAGE:KSWEEP:VAR1:POLARITY

This command sets the polarity of VAR1 sweep area for knob sweep measurement.
At *RST, this value is POSITIVE.

Syntax :PAGE:KSWEEP:VAR1:POLARITY POSITIVE | NEGATIVE | BIPOLAR

Parameter

Parameter	Type	Explanation
POSITIVE	character	sweep in positive X direction
NEGATIVE	character	sweep in negative X direction
BIPOLAR	character	sweep in positive and negative X directions

Query response POS | NEG | BIP <newline><^END>

Example
OUTPUT @Hp4155;":PAGE:KSW:VAR1:POL POS"
OUTPUT @Hp4155;":PAGE:KSW:VAR1:POL?"
ENTER @Hp4155;A\$

:PAGE:KSWEEP:VAR1:RANGE

This command sets the range of VAR1 for knob sweep measurement.
At *RST, this value is 1 V.

Syntax :PAGE:KSWEEP:VAR1:RANGE *range*

Parameter

Parameter	Type	Explanation
<i>range</i>	numeric	0.1 V to 200 V, or 1E-9 A to 1 A

Query response *range* <newline><^END>
range is NR3 response data.

Example
OUTPUT @Hp4155;":PAGE:KSW:VAR1:RANG 1"
OUTPUT @Hp4155;":PAGE:KSW:VAR1:RANG?"
ENTER @Hp4155;A

:PAGE:KSW:VAR1:STIMe

This command sets the step time (length of each step) for knob sweep measurement. At *RST, this value is 0.5 ms.

Syntax :PAGE:KSW:VAR1:STIMe *step_time* | MINimum | MAXimum

Parameter

Parameter	Type	Explanation
<i>step_time</i>	numeric	0.5E-3 to 100E-3 s (Resolution: 100E-6)

Query response *step_time* <newline><^END>

step_time is NR3 response data type.

Example

```
OUTPUT @Hp4155;":PAGE:KSW:VAR1:STIM 0.005"
OUTPUT @Hp4155;":PAGE:KSW:VAR1:STIM MAX"
OUTPUT @Hp4155;":PAGE:KSW:VAR1:STIM?"
ENTER @Hp4155;A
OUTPUT @Hp4155;":PAGE:KSW:VAR1:STIM? MAX"
ENTER @Hp4155;A
```

SCPI Commands
:PAGE:KSweep:Y

:PAGE:KSweep:Y

This command selects the measurement channel name of Y axis for knob sweep measurement.

At *RST, this value is I3.

Syntax :PAGE:KSweep:Y *var_name*

Parameter

Parameter	Type	Explanation
<i>var_name</i>	string	previously defined <i>measurement</i> channel name

Query response *var_name* <newline><^END>

var_name is string response data, but does not contain double quote characters at the beginning and end of the string.

Example
OUTPUT @Hp4155;":PAGE:KSW:Y 'VD'"
OUTPUT @Hp4155;":PAGE:KSW:Y?"
ENTER @Hp4155;A\$

:PAGE:MEAS Commands

:PAGE:MEAS commands set the MEASURE pages.

Command	Parameter
:PAGE	
:MEASure	
:MSEtup	
:ITIME	
:LONG	
:APERTure?	
[:NPLCycles]	<numeric_value>
:MEDium	
:APERTure?	
:NPLCycles?	
[:MODE]	SHORT LONG MEDium
:SHORT	
[:APERTure]	<numeric_value>
:NPLCycles?	
[:MENU]	
:SMU (1 2 3 4 5 6)	
:RANGe	<numeric_value>
:MODE	AUTO FIXEd LIMited
:VMU (1 2)	
:RANGe	<numeric_value>
:MODE	AUTO FIXEd LIMited
:WTIME	<numeric_value>
:ZCANcel	
:SMU (1 2 3 4 5 6) ?	
[:STATe]	0 1 OFF ON
:VMU (1 2) ?	

SCPI Commands

Command	Parameter
:PAGE	
:MEASure	
:OSEQuence	
[:MENU]	
:MODE	SEQuential SIMultaneous
:OSEQuence	<unit >{, <unit >} DEFault
:TRIGger	
:FUNCTion	INPut OUTPut
:POLarity	POSitive NEGative
[:STATe]	0 1 OFF ON
:TIME	<numeric_value>
:PGUSetup	
:CONStant	
:PGU(1 2)	
[:SOURce]	<numeric_value>
[:MENU]	
:PULSe	
:PGU(1 2)	
:BASE	<numeric_value>
:COUNT	<numeric_value>
:DELay	<numeric_value>
:IMPedance	LOW R50
:LEADing	<numeric_value>
:PEAK	<numeric_value>
:PERiod	<numeric_value>
:TRAILing	<numeric_value>
:WIDTh	<numeric_value>

Command	Parameter
:PAGE	
:MEASure	
:QSCV	
:CINTeg	<numeric_value>
:CNAME	<name>
:CONSTant	
:SMU(1 2 3 4 5 6)	
:COMPLiance	<numeric_value>
[:SOURce]	<numeric_value>
:VSU(1 2)	
[:SOURce]	<numeric_value>
:DELay	<numeric_value>
:HTIME	<numeric_value>
:IINTeg	<numeric_value>
:LCANcel	0 1 OFF ON
:LNAME	<name>
[:MENU]	
:RANGe	<numeric_value>
:SSTop	ABNormal COMPLiance OFF
:UNIT	SMU1 SMU2 SMU3 SMU4 SMU5 SMU6 DEFault
:VAR1	
:COMPLiance	<numeric_value>
:CSTEP	<numeric_value>
:MODE	SINGle DOUBle
:START	<numeric_value>
:STEP	<numeric_value>
:STOP	<numeric_value>
:ZCANcel	0 1 OFF ON

SCPI Commands

Command	Parameter
:PAGE	
:MEASure	
:SAMPLing	
:CONStant	
:SMU(1 2 3 4 5 6)	
:COMPLiance	<numeric_value>
[:SOURce]	<numeric_value>
:VSU(1 2)	
[:SOURce]	<numeric_value>
:HTIME	<numeric_value>
:IINTerval	<numeric_value>
[:MENU]	
:MODE	LINEar L10 L25 L50 THINnedout
:PERiod	<numeric_value> INFINity
:AUTO	0 1 OFF ON
:POINTs	<numeric_value>
:SCONdition	
:ECOUNT	<numeric_value>
:EVENT	LOW HIGH ABSLow ABSHigh
:HOFF	<numeric_value>
:NAME	<var_name>
[:STATe]	0 1 OFF ON
:THREShold	<numeric_value>

Command	Parameter
:PAGE	
:MEASure	
[:SWEep]	
:CONStant	
:SMU(1 2 3 4 5 6)	
[:SOURce]	<numeric_value>
:COMPLiance	<numeric_value>
:VSU(1 2)	
[:SOURce]	<numeric_value>
:DELay	<numeric_value>
:HTIME	<numeric_value>
[:MENU]	
:PULSe	
:PERiod	<numeric_value>
:WIDTh	<numeric_value>
:BASE	<numeric_value>
:SSTop	ABNormal COMPLiance OFF
:VAR1	
:COMPLiance	<numeric_value>
:MODE	SINGle DOUBle
:PCOMPLiance	<numeric_value>
:STATe	0 OFF
:SPACing	LINear L10 L25 L50
:START	<numeric_value>
:STEP	<numeric_value>
:STOP	<numeric_value>

SCPI Commands

Command	Parameter
:PAGE	
:MEASure	
[:SWEep]	
:VAR2	
:COMPLiance	<numeric_value>
:PCOMpliance	<numeric_value>
:STATe	0 OFF
:POINTs	<numeric_value>
:START	<numeric_value>
:STEP	<numeric_value>
:VARD	
:COMPLiance	<numeric_value>
:OFFSet	<numeric_value>
:PCOMpliance	<numeric_value>
:STATe	0 OFF
:RATio	<numeric_value>

:PAGE:MEASure:MSETup:ITIME:LONG:APERture?

:PAGE:MEASure:MSETup:ITIME:LONG:APERture?

This command returns the LONG integration time in terms of the APERTURE, which means time.

The APERTURE value is related to NPLCycles by the following equation:

$$APERture = NPLCycles / selected\ line\ frequency$$

This command has query form *only*.

At *RST, this value is 16/*selected line frequency*.

Syntax :PAGE:MEASure:MSETup:ITIME:LONG:APERture?

Query response *aperture* <newline><^END>

aperture is NR3 response data type.

Example OUTPUT @Hp4155;":PAGE:MEAS:MSET:ITIM:LONG:APER?"
ENTER @Hp4155;A

:PAGE:MEASure:MSETup:ITIME:LONG[:NPLCycle]

This command sets the LONG integration time in terms of the Number of Power Line Cycles. At *RST, this value is 16.

Syntax :PAGE:MEASure:MSETup:ITIME:LONG [:NPLCycle] *nplcycle* | MINimum | MAXimum

Parameter

Parameter	Type	Explanation
<i>nplcycle</i>	numeric	2 to 100

Query response *nplcycle* <newline><^END>

nplcycle is NR3 response data type.

Example OUTPUT @Hp4155;":PAGE:MEAS:MSET:ITIM:LONG 16"
OUTPUT @Hp4155;":PAGE:MEAS:MSET:ITIM:LONG MAX"
OUTPUT @Hp4155;":PAGE:MEAS:MSET:ITIM:LONG?"
ENTER @Hp4155;A
OUTPUT @Hp4155;":PAGE:MEAS:MSET:ITIM:LONG? MAX"
ENTER @Hp4155;A

SCPI Commands

:PAGE:MEASure:MSETup:ITIME:MEDIum:APERture?

:PAGE:MEASure:MSETup:ITIME:MEDIum:APERture?

This command returns the MEDIUM integration time in terms of the APERTURE, which means time.

This command has query form *only*.

At *RST, this value is *1/selected line frequency*.

Syntax

:PAGE:MEASure:MSETup:ITIME:MEDIum:APERture?

Query response

aperture <newline><^END>

aperture is NR3 response data type.

Example

```
OUTPUT @Hp4155;":PAGE:MEAS:MSET:ITIM:MED:APER?"  
ENTER @Hp4155;A
```

:PAGE:MEASure:MSETup:ITIME:MEDIum:NPLCycles?

This command returns the MEDIUM integration time in terms of the Number of Power Line Cycles.

The returned value is always 1 because the medium table is fixed.

This command has query form *only*.

At *RST, this value is 1.

Syntax

:PAGE:MEASure:MSETup:ITIME:MEDIum:NPLCycles?

Query response

nplcycles <newline><^END>

nplcycles is NR3 response data type.

Example

```
OUTPUT @Hp4155;":PAGE:MEAS:MSET:ITIM:MED:NPLC?"  
ENTER @Hp4155;A
```

:PAGE:MEASure:MSETup:ITIME[:MODE]

This command selects the INTEGRATION TIME.

At *RST, this value is SHORt.

Syntax

:PAGE:MEASure:MSETup:ITIME [:MODE] SHORt | LONG | MEDium

Parameter

Parameter	Type	Explanation
SHORt	character	short integration time
LONG	character	long integration time
MEDium	character	medium integration time

Query response

SHOR | LONG | MED <newline><^END>

Example

```
OUTPUT @Hp4155;":PAGE:MEAS:MSET:ITIM LONG"  
OUTPUT @Hp4155;":PAGE:MEAS:MSET:ITIM?"  
ENTER @Hp4155;A$
```

SCPI Commands

:PAGE:MEASure:MSETup:ITIME:SHORT[:APERture]

:PAGE:MEASure:MSETup:ITIME:SHORT[:APERture] **]**

This command sets the SHORT integration time in terms of the APERTURE, which means time.

The parameter has units of seconds.

At *RST, this value is 640 μ s.

Syntax

:PAGE:MEASure:MSETup:ITIME:SHORT [:APERture] *aperture* | MINimum | MAXimum

Parameter

Parameter	Type	Explanation
<i>aperture</i>	numeric	8E-5 to 1.92E-3 (s)

Query response

aperture <newline><^END>

aperture is NR3 response data type.

Example

```
OUTPUT @Hp4155;":PAGE:MEAS:MSET:ITIM:SHORT 1E-3"  
OUTPUT @Hp4155;":PAGE:MEAS:MSET:ITIM:SHORT MIN"  
OUTPUT @Hp4155;":PAGE:MEAS:MSET:ITIM:SHORT?"  
ENTER @Hp4155;A  
OUTPUT @Hp4155;":PAGE:MEAS:MSET:ITIM:SHORT? MIN"  
ENTER @Hp4155;A
```

:PAGE:MEASure:MSETup:ITIME:SHORT:NPLCycles?

:PAGE:MEASure:MSETup:ITIME:SHORT:NPLCycles?

This command returns the SHORT integration time in terms of the Number of Power Line Cycles.

The NPLCycle value is related to APERTure by the equation:

$$NPLCycles = APERTure \times \text{selected line frequency}$$

This command has query form *only*.

At *RST, this value is $640 \mu\text{s} \times \text{selected line frequency}$.

Syntax :PAGE:MEASure:MSETup:ITIME:SHORT:NPLCycles?

Query response *nplcycle* <newline><^END>

nplcycle is NR3 response data type.

Example OUTPUT @Hp4155;":PAGE:MEAS:MSET:ITIM:SHORT:NPLC?"
ENTER @Hp4155;A

:PAGE:MEASure:MSETup[:MENU]

This command changes the present display page to MEASURE: MEASURE SETUP page.

This command does not have query form.

Syntax :PAGE:MEASure:MSETup [:MENU]

Example OUTPUT @Hp4155;":PAGE:MEAS:MSET"

SCPI Commands

:PAGE:MEASure:MSETup:SMU<n>|:VMU<n> :RANGe

:PAGE:MEASure:MSETup:SMU<n>|:VMU<n> :RANGe

This command sets the measurement RANGE of SMU<n> or VMU<n>.

<n> is required to specify SMU or VMU number. Valid numbers are SMU1 through SMU6 (depending on the configuration) and VMU1 through VMU2.

If the RANGE:MODE is AUTO, this parameter is not used.

The specified SMU or VMU must not be DISable.

Syntax

:PAGE:MEASure:MSETup:SMU<n> | :VMU<n>:RANGe *range* | MINimum | MAXimum

Parameter

Parameter	Type	Explanation
<i>range</i>	numeric	For voltage measurement using SMU: 2, 20, 40, 100, 200 V
		For current measurement using SMU: 10E-12, 100E-12, 1E-9, 10E-9, 100E-9, 1E-6, 10E-6, 100E-6, 1E-3, 10E-3, 100E-3, 1 A
		For VMU: 0.2, 2, 20 V

Query response

range <newline><^END>

range is NR3 response data type.

Example

```
OUTPUT @Hp4155;":PAGE:MEAS:MSET:SMU1:RANG 2"
```

```
OUTPUT @Hp4155;":PAGE:MEAS:MSET:VMU1:RANG MAX"
```

```
OUTPUT @Hp4155;":PAGE:MEAS:MSET:SMU1:RANG?"  
ENTER @Hp4155;A
```

```
OUTPUT @Hp4155;":PAGE:MEAS:MSET:SMU1:RANG? MAX"  
ENTER @Hp4155;A
```

:PAGE:MEASure:MSETup:SMU<n>|:VMU<n>:RANGe:MODE

:PAGE:MEASure:MSETup:SMU<n>|:VMU<n>:RANGe:MODE

This command selects the ranging MODE of SMU<n> or VMU<n>.

<n> is required to specify SMU or VMU number. Valid numbers are SMU1 through SMU6 (depending on the configuration) and VMU1 through VMU2.

The specified SMU or VMU must not be DISable.

Syntax

```
:PAGE:MEASure:MSETup:SMU<n> | :VMU<n>:RANGe:MODE AUTO | FIXed | LIMited
```

Parameter

Parameter	Type	Explanation
AUTO	character	auto range mode
FIXed	character	fixed range mode
LIMited	character	limited auto range mode

Query response

```
AUTO | FIX | LIM <newline><^END>
```

Example

```
OUTPUT @Hp4155;":PAGE:MEAS:MSET:SMU1:RANG:MODE AUTO"
OUTPUT @Hp4155;":PAGE:MEAS:MSET:SMU1:RANG:MODE?"
ENTER @Hp4155;A$
```

SCPI Commands
:PAGE:MEASure:MSETup:WTIME

:PAGE:MEASure:MSETup:WTIME

This command sets the WAIT TIME multiplier for the measurement. The default wait time is multiplied by this value.

Actual Wait Time = Default Wait Time × wait time

At *RST, this value is 1.

Syntax :PAGE:MEASure:MSETup:WTIME *wait_time* | MINimum | MAXimum

Parameter

Parameter	Type	Explanation
<i>wait_time</i>	numeric	0 to 10 with resolution 0.1.

Query response *wait_time* <newline><^END>

wait_time is NR3 response data type.

Example

```
OUTPUT @Hp4155;":PAGE:MEAS:MSET:WTIM 1.0"
OUTPUT @Hp4155;":PAGE:MEAS:MSET:WTIM MAX"
OUTPUT @Hp4155;":PAGE:MEAS:MSET:WTIM?"
ENTER @Hp4155;A
OUTPUT @Hp4155;":PAGE:MEAS:MSET:WTIM? MAX"
ENTER @Hp4155;A
```

:PAGE:MEASure:MSETup:ZCANcel:SMU<n>?:VMU<n>?

This command query returns whether the ZERO OFFSET CANCEL mode is enabled for the specified unit.

If :PAGE:MEAS:MSET:ZCANcel[:STATe] is OFF, this query always returns 0.

<n> is required to specify SMU or VMU number. Valid numbers are SMU1 through SMU6 (depending on the configuration) and VMU1 through VMU2.

The specified SMU or VMU must not be DISable.

This command has query form *only*.

Syntax :PAGE:MEASure:MSETup:ZCANcel:SMU<n>?|:VMU<n>?

Query response 0 | 1 <newline><<^END>

Parameter	Type	Explanation
0	boolean	zero offset cancel is not enabled.
1	boolean	zero offset cancel is enabled.

Example
 OUTPUT @Hp4155;":PAGE:MEAS:MSET:ZCAN:SMU1?"
 ENTER @Hp4155;A

See also :PAGE:MEAS:MSET:ZCAN[:STATe]

:PAGE:MEASure:MSETup:ZCANcel[:STATe]

This command controls whether the ZERO OFFSET CANCEL mode is enabled.

At *RST, this value is OFF.

Syntax :PAGE:MEASure:MSETup:ZCANcel [:STATe] OFF | ON | 0 | 1

Parameter

Parameter	Type	Explanation
OFF or 0	boolean	zero offset cancel is not enabled for any units.
ON or 1	boolean	zero offset cancel is enabled depending on the settings of each unit.

Query response 0 | 1 <newline><<^END>

Example
 OUTPUT @Hp4155;":PAGE:MEAS:MSET:ZCAN ON"
 OUTPUT @Hp4155;":PAGE:MEAS:MSET:ZCAN?"
 ENTER @Hp4155;A

SCPI Commands
:PAGE:MEASure:OSEquence[:MENU]

:PAGE:MEASure:OSEquence[:MENU]

This command changes the present display page to MEASURE: OUTPUT SEQUENCE page. This command does not have query form.

Syntax :PAGE:MEASure:OSEquence [:MENU]

Example OUTPUT @Hp4155; ":PAGE:MEAS:OSEQ"

:PAGE:MEASure:OSEquence:MODE

This command selects the output sequence mode for sampling measurement.

You use this command only if the measurement mode is sampling.

At *RST, this value is *SIMultaneous* for sampling measurement.

Syntax :PAGE:MEASure:OSEquence:MODE SEQuential | SIMultaneous

Parameter

Parameter	Type	Explanation
SEQuential	character	sequential output
SIMultaneous	character	simultaneous output

Query response SEQ | SIM <newline><^END>

Example OUTPUT @Hp4155; ":PAGE:MEAS:OSEQ:MODE SIM"
OUTPUT @Hp4155; ":PAGE:MEAS:OSEQ:MODE?"
ENTER @Hp4155;A\$

:PAGE:MEASure:OSEquence:OSEquence

This command sets the OUTPUT SEQUENCE.

The source channels output in the order specified by the OUTPUT SEQUENCE.

Unspecified units output in default order after the specified units.

At *RST, the output sequence is SMU1-SMU2-SMU3-SMU4-SMU5-SMU6-VSU1-VSU2-PGU1-PGU2.

Syntax :PAGE:MEASure:OSEquence:OSEquence *unit* { , *unit* } | DEFault

Parameter

Parameter	Type	Explanation
<i>unit</i>	string	SMU1, SMU2, SMU3, SMU4, SMU5, SMU6, VSU1, VSU2, PGU1, or PGU2. See Example.
<i>Default</i>	character	Sets source output order as follows: SMU1-SMU2-SMU3-SMU4-SMU5-SMU6- VSU1-VSU2-PGU1-PGU2.

Query response

unit { , *unit*} <newline><^END>

Response is a list of units separated by commas, and is string response data, but does not contain double quote characters at the beginning and end of the string.

Example

```
OUTPUT @Hp4155;":PAGE:MEAS:OSEQ:OSEQ SMU4,PGU1,SMU3"
```

The result order is SMU4-PGU1-SMU3-SMU1-SMU2-SMU5-SMU6-VSU1-VSU2-PGU2.

```
OUTPUT @Hp4155;":PAGE:MEAS:OSEQ:OSEQ?"  
ENTER @Hp4155;A$
```

:PAGE:MEASure:OSEquence:TRIGger:FUNCTION

This command selects the trigger function.

At *RST, this value is OUTPut.

Syntax

:PAGE:MEASure:OSEquence:TRIGger:FUNCTION INPut | OUTPut

Parameter

Parameter	Type	Explanation
INPut	character	trigger input function
OUTPut	character	trigger output function

Query response

INP | OUTP <newline><^END>

Example

```
OUTPUT @Hp4155;":PAGE:MEAS:OSEQ:TRIG:FUNC INP"
```

```
OUTPUT @Hp4155;":PAGE:MEAS:OSEQ:TRIG:FUNC?"  
ENTER @Hp4155;A$
```

SCPI Commands

:PAGE:MEASure:OSEquence:TRIGger:POLarity

:PAGE:MEASure:OSEquence:TRIGger:POLarity

This command sets the POLARITY of trigger signal.

At *RST, this value is POSitive.

Syntax

:PAGE:MEASure:OSEquence:TRIGger:POLarity POSitive | NEGative

Parameter

Parameter	Type	Explanation
POSitive	character	polarity is positive
NEGative	character	polarity is negative

Query response

POS | NEG <newline><^END>

Example

```
OUTPUT @Hp4155;":PAGE:MEAS:OSEQ:TRIG:POL POS"  
OUTPUT @Hp4155;":PAGE:MEAS:OSEQ:TRIG:POL?"  
ENTER @Hp4155;A$
```

:PAGE:MEASure:OSEquence:TRIGger[:STATe]

This command controls whether the trigger function is enabled.

At *RST, this value is OFF.

Syntax

:PAGE:MEASure:OSEquence:TRIGger [:STATe] OFF | ON | 0 | 1

Parameter

Parameter	Type	Explanation
OFF <i>or</i> 0	boolean	trigger function is disabled
ON <i>or</i> 1	boolean	trigger function is enabled

Query response

0 | 1 <newline><^END>

Example

```
OUTPUT @Hp4155;":PAGE:MEAS:OSEQ:TRIG ON"  
OUTPUT @Hp4155;":PAGE:MEAS:OSEQ:TRIG?"  
ENTER @Hp4155;A
```

:PAGE:MEASure:OSequence:TRIGger:TIME

This command sets the trigger output timing.

If TRIGger:FUNction is INPut, this parameter is not used.

At *RST, this value is 0, which means free run.

Syntax

:PAGE:MEASure:OSequence:TRIGger:TIME *time* | MINimum | MAXimum

Parameter

Parameter	Type	Explanation
<i>time</i>	numeric	0 to 1 (when SMU pulse is not used)
		0 to 0.0327 or pulse width, whichever is shorter. (when SMU pulse is used)

Query response

time <newline><^END>

time is NR3 response data type.

Example

```
OUTPUT @Hp4155;":PAGE:MEAS:OSEQ:TRIG:TIME 0.01"
OUTPUT @Hp4155;":PAGE:MEAS:OSEQ:TRIG:TIME MAX"
OUTPUT @Hp4155;":PAGE:MEAS:OSEQ:TRIG:TIME?"
ENTER @Hp4155;A
OUTPUT @Hp4155;":PAGE:MEAS:OSEQ:TRIG:TIME? MAX"
ENTER @Hp4155;A
```

SCPI Commands

:PAGE:MEASure:PGUSetup:CONStant:PGU<n>[:SOURce]

:PAGE:MEASure:PGUSetup:CONStant:PGU<n>[:SO URce]

This command sets the constant SOURCE value of PGU<n>.

<n> is required to specify PGU number. Valid PGU numbers are PGU1 through PGU2.

You use this command only if the specified PGU is set to V mode (not VPULSE) by the :PAGE:CHAN:PGU<n>:MODE command.

At *RST, this value is 0.

Syntax

:PAGE:MEASure:PGUSetup:CONStant:PGU<n> [:SOURce] *source* | MINImum | MAXImum

Parameter

Parameter	Type	Explanation
<i>source</i>	numeric	-40 to 40 V

Query response

source <newline><^END>

source is NR3 response data type.

Example

```
OUTPUT @Hp4155;":PAGE:MEAS:PGUS:CONS:PGU1 10"  
OUTPUT @Hp4155;":PAGE:MEAS:PGUS:CONS:PGU1 MAX"  
OUTPUT @Hp4155;":PAGE:MEAS:PGUS:CONS:PGU1?"  
ENTER @Hp4155;A  
OUTPUT @Hp4155;":PAGE:MEAS:PGUS:CONS:PGU1? MAX"  
ENTER @Hp4155;A
```

:PAGE:MEASure:PGUSetup[:MENU]

This command changes the present display page to MEASURE: PGU SETUP.

This command does not have query form.

Syntax

:PAGE:MEASure:PGUSetup [:MENU]

Example

```
OUTPUT @Hp4155;":PAGE:MEAS:PGUS"
```

:PAGE:MEASure:PGUSetup:PULSe:PGU<n>:BASE

This command sets the BASE VALUE of PGU<n>.

<n> is required to specify PGU number. Valid PGU numbers are PGU1 through PGU2.

You use this command only if the specified PGU is set to VPULSe mode (not V) by the :PAGE:CHAN:PGU<n>:MODE command.

At *RST, this value is 0.

Syntax

:PAGE:MEASure:PGUSetup:PULSe:PGU<n>:BASE *base* | MINimum | MAXimum

Parameter

Parameter	Type	Explanation
<i>base</i>	numeric	-40 to 40 V

Query response

base <newline><^END>

base is NR3 response data type.

Example

```
OUTPUT @Hp4155;":PAGE:MEAS:PGUS:PULS:PGU1:BASE 1"
OUTPUT @Hp4155;":PAGE:MEAS:PGUS:PULS:PGU1:BASE MIN"
OUTPUT @Hp4155;":PAGE:MEAS:PGUS:PULS:PGU1:BASE?"
ENTER @Hp4155;A
OUTPUT @Hp4155;":PAGE:MEAS:PGUS:PULS:PGU1:BASE? MIN"
ENTER @Hp4155;A
```

SCPI Commands

:PAGE:MEASure:PGUSetup:PULSe:PGU<n>:COUNT

:PAGE:MEASure:PGUSetup:PULSe:PGU<n>:COUNT

This command sets the output PULSE COUNT of PGU<n>.

<n> is required to specify PGU number. Valid PGU numbers are PGU1 through PGU2.

PGU1:COUNT and PGU2:COUNT are always set to the same value.

You use this command only if the specified PGU is set to VPULSe mode (not V) by the :PAGE:CHAN:PGU<n>:MODE command.

At *RST, this value is 0.

Syntax

:PAGE:MEASure:PGUSetup:PULSe:PGU<n>:COUNT *count* | MINimum | MAXimum

Parameter

Parameter	Type	Explanation
<i>count</i>	numeric	0 to 65535 (0 means free run)

Query response

count <newline><^END>

count is NR1 response data type.

Example

OUTPUT @Hp4155;":PAGE:MEAS:PGUS:PULS:PGU1:COUNT 10"

OUTPUT @Hp4155;":PAGE:MEAS:PGUS:PULS:PGU1:COUNT MAX"

OUTPUT @Hp4155;":PAGE:MEAS:PGUS:PULS:PGU1:COUNT?"

ENTER @Hp4155;A

OUTPUT @Hp4155;":PAGE:MEAS:PGUS:PULS:PGU1:COUNT? MAX"

ENTER @Hp4155;A

:PAGE:MEASure:PGUSetup:PULSe:PGU<n>:DELay

:PAGE:MEASure:PGUSetup:PULSe:PGU<n>:DELay

This command sets the DELAY TIME of PGU<n>.

<n> is required to specify PGU number. Valid PGU numbers are PGU1 through PGU2.

You use this command only if the specified PGU is set to VPULSe mode (not V) by the :PAGE:CHAN:PGU<n>:MODE command.

At *RST, this value is 0.

Syntax

:PAGE:MEASure:PGUSetup:PULSe:PGU<n>:DELay *delay_time* | MINimum | MAXimum

Parameter

Parameter	Type	Explanation
<i>delay_time</i>	numeric	0 to 10 (s)

Query response

delay_time <newline><^END>

delay_time is NR3 response data type.

Example

```
OUTPUT @Hp4155;":PAGE:MEAS:PGUS:PULS:PGU1:DEL 1"
```

```
OUTPUT @Hp4155;":PAGE:MEAS:PGUS:PULS:PGU1:DEL MAX"
```

```
OUTPUT @Hp4155;":PAGE:MEAS:PGUS:PULS:PGU1:DEL?"
ENTER @Hp4155;A
```

```
OUTPUT @Hp4155;":PAGE:MEAS:PGUS:PULS:PGU1:DEL? MAX"
ENTER @Hp4155;A
```

SCPI Commands

:PAGE:MEASure:PGUSetup:PULSe:PGU<n>:IMPedance

:PAGE:MEASure:PGUSetup:PULSe:PGU<n>:IMPedance

This command sets the output IMPEDANCE of PGU<n>.

<n> is required to specify PGU number. Valid PGU numbers are PGU1 through PGU2.

You use this command only if the specified PGU is set to `VPULSe` mode (not `V`) by the `:PAGE:CHAN:PGU<n>:MODE` command.

At `*RST`, this value is `LOW`.

Syntax

:PAGE:MEASure:PGUSetup:PULSe:PGU<n>:IMPedance `LOW` | `R50`

Parameter

Parameter	Type	Explanation
<code>LOW</code>	character	low impedance
<code>R50</code>	character	50 Ω

Query response

`LOW` | `R50` <newline><^END>

Example

```
OUTPUT @Hp4155;":PAGE:MEAS:PGUS:PULS:PGU1:IMP LOW"
```

```
OUTPUT @Hp4155;":PAGE:MEAS:PGUS:PULS:PGU1:IMP?"
```

```
ENTER @Hp4155;A$
```

:PAGE:MEASure:PGUSetup:PULSe:PGU<n>:LEADIn g

This command sets the leading-edge transition time (LEADING TIME) of PGU<n>.

<n> is required to specify PGU number. Valid PGU numbers are PGU1 through PGU2.

You use this command only if the specified PGU is set to *VPULSe* mode (not *V*) by the `:PAGE:CHAN:PGU<n>:MODE` command.

At *RST, this value is 100 ns.

Syntax

:PAGE:MEASure:PGUSetup:PULSe:PGU<n>:LEADIn *leading_time* | MINimum
| MAXimum

Parameter

Parameter	Type	Explanation
<i>leading_time</i>	numeric	1E-7 to 1E-2 (s)

Query response

leading_time <newline><^END>

leading_time is NR3 response data type.

Example

```
OUTPUT @Hp4155;":PAGE:MEAS:PGUS:PULS:PGU1:LEAD 0.001"
OUTPUT @Hp4155;":PAGE:MEAS:PGUS:PULS:PGU1:LEAD MIN"
OUTPUT @Hp4155;":PAGE:MEAS:PGUS:PULS:PGU1:LEAD?"
ENTER @Hp4155;A
OUTPUT @Hp4155;":PAGE:MEAS:PGUS:PULS:PGU1:LEAD? MIN"
ENTER @Hp4155;A
```

SCPI Commands

:PAGE:MEASure:PGUSetup:PULSe:PGU<n>:PEAK

:PAGE:MEASure:PGUSetup:PULSe:PGU<n>:PEAK

This command sets the PEAK VALUE of PGU<n>.

<n> is required to specify PGU number. Valid PGU numbers are PGU1 through PGU2.

You use this command only if the specified PGU is set to VPULSe mode (not V) by the :PAGE:CHAN:PGU<n>:MODE command.

At *RST, this value is 0.1 V.

Syntax

:PAGE:MEASure:PGUSetup:PULSe:PGU<n>:PEAK *peak* | MINimum | MAXimum

Parameter

Parameter	Type	Explanation
<i>peak</i>	numeric	-40 to 40 V

Query response

peak <newline><^END>

peak is NR3 response data type.

Example

```
OUTPUT @Hp4155;":PAGE:MEAS:PGUS:PULS:PGU1:PEAK 5"
```

```
OUTPUT @Hp4155;":PAGE:MEAS:PGUS:PULS:PGU1:PEAK MAX"
```

```
OUTPUT @Hp4155;":PAGE:MEAS:PGUS:PULS:PGU1:PEAK?"  
ENTER @Hp4155;A
```

```
OUTPUT @Hp4155;":PAGE:MEAS:PGUS:PULS:PGU1:PEAK? MAX"  
ENTER @Hp4155;A
```

:PAGE:MEASure:PGUSetup:PULSe:PGU<n>:PERiod

This command sets the pulse PERIOD of PGU<n>.

<n> is required to specify PGU number. Valid PGU numbers are PGU1 through PGU2.

PGU1:PERiod and PGU2:PERiod are always set to the same value.

You use this command only if the specified PGU is set to VPULse mode (not V) by the :PAGE:CHAN:PGU<n>:MODE command.

At *RST, this value is 10 ms.

Syntax

:PAGE:MEASure:PGUSetup:PULSe:PGU<n>:PERiod *period* | MINimum | MAXimum

Parameter

Parameter	Type	Explanation
<i>period</i>	numeric	2E-6 to 10 (s)

Query response

period <newline><^END>

period is NR3 response data type.

Example

```
OUTPUT @Hp4155;":PAGE:MEAS:PGUS:PULS:PGU1:PER 0.01"
```

```
OUTPUT @Hp4155;":PAGE:MEAS:PGUS:PULS:PGU1:PER MIN"
```

```
OUTPUT @Hp4155;":PAGE:MEAS:PGUS:PULS:PGU1:PER?"
```

```
ENTER @Hp4155;A
```

```
OUTPUT @Hp4155;":PAGE:MEAS:PGUS:PULS:PGU1:PER? MIN"
```

```
ENTER @Hp4155;A
```

SCPI Commands

:PAGE:MEASure:PGUSetup:PULSe:PGU<n>:TRAILing

:PAGE:MEASure:PGUSetup:PULSe:PGU<n>:TRAILing

This command sets the trailing-edge transition time (TRAILING TIME) of PGU<n>.

<n> is required to specify PGU number. Valid PGU numbers are PGU1 through PGU2.

You use this command only if the specified PGU is set to `VPULSe` mode (not `V`) by the `:PAGE:CHAN:PGU<n>:MODE` command.

At *RST, this value is 100 ns.

Syntax

:PAGE:MEASure:PGUSetup:PULSe:PGU<n>:TRAILing *trailing_time* | MINimum | MAXimum

Parameter

Parameter	Type	Explanation
<i>trailing_time</i>	numeric	1E-7 to 1E-2 (s)

Query response

trailing_time <newline><^END>

trailing_time is NR3 response data type.

Example

```
OUTPUT @Hp4155;":PAGE:MEAS:PGUS:PULS:PGU1:TRA 0.001"
```

```
OUTPUT @Hp4155;":PAGE:MEAS:PGUS:PULS:PGU1:TRA MIN"
```

```
OUTPUT @Hp4155;":PAGE:MEAS:PGUS:PULS:PGU1:TRA?"
```

```
ENTER @Hp4155;A
```

```
OUTPUT @Hp4155;":PAGE:MEAS:PGUS:PULS:PGU1:TRA? MIN"
```

```
ENTER @Hp4155;A
```

:PAGE:MEASure:PGUSetup:PULSe:PGU<n>:WIDTh

:PAGE:MEASure:PGUSetup:PULSe:PGU<n>:WIDTh

This command sets the pulse WIDTH of PGU<n>.

<n> is required to specify PGU number. Valid PGU numbers are PGU1 through PGU2.

You use this command only if the specified PGU is set to VPULSe mode (not V) by the :PAGE:CHAN:PGU<n>:MODE command.

At *RST, this value is 5 ms.

Syntax

:PAGE:MEASure:PGUSetup:PULSe:PGU<n>:WIDTh *width* | MINimum | MAXimum

Parameter

Parameter	Type	Explanation
<i>width</i>	numeric	1E-6 to 9.99 (s)

Query response

width <newline><<^END>

width is NR3 response data type.

Example

```
OUTPUT @Hp4155;":PAGE:MEAS:PGUS:PULS:PGU1:WIDTH 0.005"
OUTPUT @Hp4155;":PAGE:MEAS:PGUS:PULS:PGU1:WIDTH MIN"
OUTPUT @Hp4155;":PAGE:MEAS:PGUS:PULS:PGU1:WIDTH?"
ENTER @Hp4155;A
OUTPUT @Hp4155;":PAGE:MEAS:PGUS:PULS:PGU1:WIDTH? MIN"
ENTER @Hp4155;A
```

SCPI Commands
:PAGE:MEASure:QSCV:CINTeg

:PAGE:MEASure:QSCV:CINTeg

This command sets the integration time for the capacitance measurement in the Quasi-static CV measurement mode. The value is rounded as follows:

$$\text{integration time} = nplc / \text{selected line frequency}$$

where, *nplc* means the number of power line cycle. The value must be integer in the range: 2 to 20000.

At *RST, this value is $5 / \text{selected line frequency}$, so a 50 Hz line frequency has an integration time of 0.1 s, and a 60 Hz line frequency has an integration time of approximately 0.083 s.

This command also has a query form.

Syntax

:PAGE:MEASure:QSCV:CINTeg *integ_time*
:PAGE:MEASure:QSCV:CINTeg?

Parameter

Parameter	Type	Explanation
<i>integ_time</i>	numeric	Integration time in seconds. 0.04 to 400 s at 50 Hz line frequency. 0.033333 to 333.33 s at 60 Hz line frequency.

Query response

integ_time <newline><^END>

integ_time is an NR3 response data type.

Example

OUTPUT @Hp4155;":PAGE:MEAS:QSCV:CINT 0.4"

The above example sets the integration time to 0.4 s (=20/50=24/60) for both 50 Hz and 60 Hz line frequencies.

OUTPUT @Hp4155;":PAGE:MEAS:QSCV:CINT?"
ENTER @Hp4155;A

:PAGE:MEASure:QSCV:CNAME

This command sets the variable name of the measurement result data for the Quasi-static CV measurements. The variable is available only for the Quasi-static CV measurement mode. This command also has a query form.

At *RST, this value is set to CAP.

Syntax :PAGE:MEASure:QSCV:CNAME *name*
:PAGE:MEASure:QSCV:CNAME?

Parameter

Parameter	Type	Explanation
<i>name</i>	string	String of up to 6 alphanumeric characters. The first character must be an alpha character.

Query response *name* <newline><^END>

Example
OUTPUT @Hp4155;":PAGE:MEAS:QSCV:CNAME 'CDATA'"
OUTPUT @Hp4155;":PAGE:MEAS:QSCV:CNAME?"
ENTER @Hp4155;A\$

SCPI Commands

:PAGE:MEASure:QSCV:CONStant:SMU<n>:COMPLiance

:PAGE:MEASure:QSCV:CONStant:SMU<n>:COMPLiance

This command sets the COMPLIANCE value of the source SMU<n> for the Quasi-static CV measurement. This command also has a query form.

<n> is required to specify the SMU number. Valid SMU numbers are SMU1 through SMU6, depending on the configuration.

Use this command only if the function of the specified SMU is CONStant and the mode is not COMMon.

Syntax

:PAGE:MEASure:QSCV:CONStant:SMU<n>:COMPLiance *compliance* | MINimum | MAXimum

:PAGE:MEASure:QSCV:CONStant:SMU<n>:COMPLiance?

Parameter

Parameter	Type	Explanation
<i>compliance</i>	numeric	–200 to 200 V or –1 to 1 A. The range of this value depends on the SMU type being used.

Query response

compliance <newline><^END>

compliance is an NR3 response data type.

Example

```
OUTPUT @Hp4155;":PAGE:MEAS:QSCV:CONS:SMU1:COMP 0.1"
```

```
OUTPUT @Hp4155;":PAGE:MEAS:QSCV:CONS:SMU1:COMP?"  
ENTER @Hp4155;A
```

:PAGE:MEASure:QSCV:CONStant:SMU<n>[:SOURce]

:PAGE:MEASure:QSCV:CONStant:SMU<n>[:SOURce]

This command sets the SOURCE value of the constant source SMU<n> for the Quasi-static CV measurement. This command also has a query form.

Where <n> is required to specify the SMU number. Valid SMU numbers are SMU1 through SMU6, depending on the configuration.

Use this command only if the function of the specified SMU is CONStant and the mode is not COMMOn.

At *RST, this value is set to 0.

Syntax

:PAGE:MEASure:QSCV:CONStant:SMU<n>[:SOURce] *source* | MINimum | MAXimum

:PAGE:MEASure:QSCV:CONStant:SMU<n>[:SOURce]?

Parameter

Parameter	Type	Explanation
<i>source</i>	numeric	–200 to 200 V or –1 to 1 A. The range of this value depends on the type of SMU being used.

Query response

source <newline><^END>

source is an NR3 response data type.

Example

```
OUTPUT @Hp4155;":PAGE:MEAS:QSCV:CONS:SMU1 10"
```

```
OUTPUT @Hp4155;":PAGE:MEAS:QSCV:CONS:SMU1?"
ENTER @Hp4155;A
```

SCPI Commands

:PAGE:MEASure:QSCV:CONStant:VSU<n>[:SOURce]

:PAGE:MEASure:QSCV:CONStant:VSU<n>[:SOURce]

This command sets the SOURCE value of the constant source VSU<n> for the Quasi-static CV measurement. This command also has a query form.

Where <n> is required to specify VSU number. Valid VSU numbers are VSU1 and VSU2.

Use this command only if the function of the specified VSU is CONStant.

At *RST, this value is set to 0.

Syntax

:PAGE:MEASure:QSCV:CONStant:VSU<n>[:SOURce] *source* | MINimum | MAXimum

:PAGE:MEASure:QSCV:CONStant:VSU<n>[:SOURce]?

Parameter

Parameter	Type	Explanation
<i>source</i>	numeric	-20 to 20 V

Query response

source <newline><^END>

source is an NR3 response data type.

Example

```
OUTPUT @Hp4155;":PAGE:MEAS:QSCV:CONS:VSU1 10"
```

```
OUTPUT @Hp4155;":PAGE:MEAS:QSCV:CONS:VSU1?"  
ENTER @Hp4155;A
```

:PAGE:MEASure:QSCV:DELay

This command sets the DELAY TIME for Quasi-static CV measurements. The delay time is the time from the start of each sweep step to the start of the measurement. This command also has a query form.

At *RST, this value is set to 0.

Syntax :PAGE:MEASure:QSCV:DELay *delay_time*
:PAGE:MEASure:QSCV:DELay?

Parameter

Parameter	Type	Explanation
<i>delay_time</i>	numeric	0 to 65.535 (s). Resolution: 100 μ s.

Query response *delay_time* <newline><^END>

delay_time is an NR3 response data type.

Example
 OUTPUT @Hp4155;":PAGE:MEAS:QSCV:DEL 1.5"
 OUTPUT @Hp4155;":PAGE:MEAS:QSCV:DEL?"
 ENTER @Hp4155;A

SCPI Commands
:PAGE:MEASure:QSCV:HTIME

:PAGE:MEASure:QSCV:HTIME

This command sets the HOLD TIME for Quasi-static CV measurements. The hold time is the time from the start of the first sweep step to the start of the delay time. This command also has a query form.

At *RST, this value is set to 0.

Syntax :PAGE:MEASure:QSCV:HTIME *hold_time*

:PAGE:MEASure:QSCV:HTIME?

Parameter

Parameter	Type	Explanation
<i>hold_time</i>	numeric	0 to 655.35 (s). Resolution: 10 ms.

Query response *hold_time* <newline><^END>

hold_time is an NR3 response data type.

Example

```
OUTPUT @Hp4155;":PAGE:MEAS:QSCV:HTIM 1.5"  
OUTPUT @Hp4155;":PAGE:MEAS:QSCV:HTIM?"  
ENTER @Hp4155;A
```

:PAGE:MEASure:QSCV:IINTEg

This command sets the integration time for the leakage current measurement when in the Quasi-static CV measurement mode. The value is rounded as follows:

$$\text{integration time} = nplc / \text{selected line frequency}$$

where *nplc* means the number of power line cycle. The value must be integer in the range: 1 to 100.

At *RST, this value is 5 / *selected line frequency*. For a 50 Hz line frequency, the integration time is 0.1 s. For a 60 Hz line frequency, the integration time is approximately 0.083 s.

This command also has a query form.

Syntax

```
:PAGE:MEASure:QSCV:IINTEg integ_time
:PAGE:MEASure:QSCV:IINTEg?
```

Parameter

Parameter	Type	Explanation
<i>integ_time</i>	numeric	Integration time. in second. 0.02 to 2 s at 50 Hz line frequency. 0.016667 to 1.6667 s at 60 Hz line frequency.

Query response

```
integ_time <newline><^END>
```

integ_time is an NR3 response data type.

Example

```
OUTPUT @Hp4155;":PAGE:MEAS:QSCV:IINT 0.04"
```

The above example sets the integration time to 0.04 s for a 50 Hz line frequency, and to approximately 0.033 s for a 60 Hz line frequency.

Note that 0.04 is equal to 2/50 and 2.4/60. This means 0.04 s is not suitable as an integration time at 60 Hz because *n* must be integer. In this case, the integration time is automatically set to 0.033 s (=2/60) and *n* is rounded to 2, not 3.

```
OUTPUT @Hp4155;":PAGE:MEAS:QSCV:IINT?"
ENTER @Hp4155;A
```

SCPI Commands
:PAGE:MEASure:QSCV:LCANcel

:PAGE:MEASure:QSCV:LCANcel

This command enables or disables leakage current compensation for Quasi-static CV measurements. This command also has a query form.

At *RST, this value is OFF.

Syntax :PAGE:MEASure:QSCV:LCANcel OFF | ON | 0 | 1

:PAGE:MEASure:QSCV:LCANcel?

Parameter

Parameter	Type	Explanation
OFF or 0	Boolean	Leakage current compensation is disabled.
ON or 1	Boolean	Leakage current compensation is enabled.

Query response 0 | 1 <newline><^END>

Example
OUTPUT @Hp4155;":PAGE:MEAS:QSCV:LCAN ON"
OUTPUT @Hp4155;":PAGE:MEAS:QSCV:LCAN?"
ENTER @Hp4155;A

:PAGE:MEASure:QSCV:LNAME

This command sets the variable name of the leakage current data measured during the Quasi-static CV measurements. This command also has a query form.

At *RST, this value is set to LEAK.

Syntax :PAGE:MEASure:QSCV:LNAME *name*
:PAGE:MEASure:QSCV:LNAME?

Parameter

Parameter	Type	Explanation
<i>name</i>	string	String of up to 6 alphanumeric characters. The first character must be an alpha character.

Query response *name* <newline><^END>

Example
OUTPUT @Hp4155;":PAGE:MEAS:QSCV:LNAME 'ILEAK'"
OUTPUT @Hp4155;":PAGE:MEAS:QSCV:LNAME?"
ENTER @Hp4155;A\$

:PAGE:MEASure:QSCV[:MENU]

This command displays the MEASURE: QSCV SETUP screen.

Available only in the Quasi-static CV measurement mode. An error occurs if this command is entered in another measurement mode.

Syntax :PAGE:MEASure:QSCV[:MENU]

Example OUTPUT @Hp4155;":PAGE:MEAS:QSCV"

See also :PAGE:CHANnels:CDEFinition:MODE

SCPI Commands
:PAGE:MEASure:QSCV:RANGe

:PAGE:MEASure:QSCV:RANGe

This command sets the measurement RANGE of the measurement channel used in the Quasi-static CV measurements. This command also has a query form.

At *RST, this value is set to 1E-9.

Syntax

:PAGE:MEASure:QSCV:RANGe *range* | MINimum | MAXimum

:PAGE:MEASure:QSCV:RANGe?

Parameter

Parameter	Type	Explanation
<i>range</i>	numeric	10E-12, 100E-12, 1E-9, or 10E-9 for the 4156C. 1E-9 or 10E-9 for the 4155C, MPSMU, HPSMU.

Query response

range <newline><^END>

range is an NR3 response data type.

Example

```
OUTPUT @Hp4155;":PAGE:MEAS:QSCV:RANG MAX"  
OUTPUT @Hp4155;":PAGE:MEAS:QSCV:RANG?"  
ENTER @Hp4155;A
```

:PAGE:MEASure:QSCV:SSTop

This command sets the stop condition for an abnormal status during Quasi-static CV measurements. This command also has a query form.

The following abnormal status conditions can be detected:

1. Compliance on the non-measurement unit.
2. Compliance on the leakage current measurement unit.
3. Integration time too short at the capacitance measurement.
4. Overflow on ADC.
5. Oscillation on any unit.

At *RST, this value is OFF.

Syntax

:PAGE:MEASure:QSCV:SSTop ABNormal | COMpliance | OFF

:PAGE:MEASure:QSCV:SSTop?

Parameter

Parameter	Type	Explanation
ABNormal	character	Stops sweep if an abnormal condition is detected.
COMpliance	character	Stops sweep if the condition 2 or 3 shown above is detected.
OFF	character	Continues sweep even if an abnormal condition is detected.

Query response

OFF | ABN | COMP <newline><^END>

Example

OUTPUT @Hp4155;":PAGE:MEAS:QSCV:SST ABN"

OUTPUT @Hp4155;":PAGE:MEAS:QSCV:SST?"

ENTER @Hp4155;A\$

SCPI Commands

:PAGE:MEASure:QSCV:UNIT

:PAGE:MEASure:QSCV:UNIT

This command specifies the measurement channel for Quasi-static CV measurements. This command also has a query form.

At *RST, this value is set to DEF.

Syntax

:PAGE:MEASure:QSCV:UNIT SMU1 | SMU2 | SMU3 | SMU4 | SMU5 | SMU6 | DEFault

:PAGE:MEASure:QSCV:UNIT?

Parameter

Parameter	Type	Explanation
SMU n	character	SMU n is assigned as the measurement channel, where n is integer (1 to 6).
DEFault	character	VAR1 channel is assigned as the measurement channel.

Query response

SMU1 | SMU2 | SMU3 | SMU4 | SMU5 | SMU6 <newline><^END>

Example

```
OUTPUT @Hp4155;":PAGE:MEAS:QSCV:UNIT DEF"
OUTPUT @Hp4155;":PAGE:MEAS:QSCV:UNIT?"
ENTER @Hp4155;A$
```

See also

:PAGE:CHANnels:CDEFinition:SMU:FUNCTion

:PAGE:CHANnels:CDEFinition:SMU:MODE

:PAGE:MEASure:QSCV:VAR1:COMpliance

This command sets the compliance value of the VAR1 channel for Quasi-static CV measurements. This command also has a query form.

Syntax

:PAGE:MEASure:QSCV:VAR1:COMpliance *compliance* | MINimum | MAXimum
:PAGE:MEASure:QSCV:VAR1:COMpliance?

Parameter

Parameter	Type	Explanation
<i>compliance</i>	numeric	VAR1 compliance value. -1 to 1 A. The range of this value depends on the type of VAR1 unit being used.

Query response

compliance <newline><^END>

compliance is an NR3 response data type.

Example

```
OUTPUT @Hp4155;":PAGE:MEAS:QSCV:VAR1:COMP 0.1"
OUTPUT @Hp4155;":PAGE:MEAS:QSCV:VAR1:COMP?"
ENTER @Hp4155;A
```

SCPI Commands

:PAGE:MEASure:QSCV:VAR1:CSTEp

:PAGE:MEASure:QSCV:VAR1:CSTEp

This command sets the capacitance measurement voltage for Quasi-static CV measurements. This command also has a query form.

At *RST, this value is set to 0.1.

Syntax

:PAGE:MEASure:QSCV:VAR1:CSTEp *cstep* | MINimum | MAXimum

:PAGE:MEASure:QSCV:VAR1:CSTEp?

Parameter

In the QSCV measurement, the measurement unit executes the capacitance measurement for the sweep steps except for the sweep start voltage and stop voltage. At each sweep step, the capacitance measurement is executed over the voltage range: output voltage \pm *cstep*.

Parameter	Type	Explanation
<i>cstep</i>	numeric	Capacitance measurement voltage. The minimum value is double the resolution value of the output range, and the maximum value is 10 V.

The value must be $\leq |step|$ (sweep step voltage). If you set the value greater than $|step|$, the *cstep* is automatically set to the same value as $|step|$.

If you set the value greater than or equal to $|stop-start|$, the measurement unit executes a one-point capacitance measurement between the *start* and *stop* values.

Query response

cstep <newline><^END>

cstep is an NR3 response data type.

Remarks

If you set the sweep *start*, *stop*, *step*, and *cstep* values as shown below, the capacitance measurement is executed over the following voltage ranges:

start=0, *stop*=4, *step*=1 (number of sweep steps=3), *cstep*=1

measurement voltage at the 1st sweep step: 0.5 to 1.5 V

measurement voltage at the 2nd sweep step: 1.5 to 2.5 V

measurement voltage at the 3rd sweep step: 2.5 to 3.5 V

Example

```
OUTPUT @Hp4155;":PAGE:MEAS:QSCV:VAR1:CSTE 0.1"
```

```
OUTPUT @Hp4155;":PAGE:MEAS:QSCV:VAR1:CSTE?"
```

```
ENTER @Hp4155;A
```

:PAGE:MEASure:QSCV:VAR1:MODE

This command sets the VAR1 sweep mode for Quasi-static CV measurements. This command also has a query form.

At *RST, this value is set to SING

Syntax

:PAGE:MEASure:QSCV:VAR1:MODE SINGle | DOUBle

:PAGE:MEASure:QSCV:VAR1:MODE?

Parameter

Parameter	Type	Explanation
SINGle	character	Single mode (start to stop)
DOUBle	character	Double mode (start to stop to start)

Query response

SING | DOUB <newline><^END>

Example

```
OUTPUT @Hp4155;":PAGE:MEAS:QSCV:VAR1:MODE SING"
```

```
OUTPUT @Hp4155;":PAGE:MEAS:QSCV:VAR1:MODE?"
```

```
ENTER @Hp4155;A$
```

SCPI Commands

:PAGE:MEASure:QSCV:VAR1:START

:PAGE:MEASure:QSCV:VAR1:START

This command sets the VAR1 sweep start value for Quasi-static CV measurements. The sweep source forces the start voltage when starting the sweep output. This command also has a query form.

At *RST, this value is set to 0.

Syntax

:PAGE:MEASure:QSCV:VAR1:START *start* | MINimum | MAXimum

:PAGE:MEASure:QSCV:VAR1:START?

Parameter

Parameter	Type	Explanation
<i>start</i>	numeric	VAR1 sweep start value. –200 to 200 V. The range of this value depends on the type of VAR1 unit being used.

Query response

start <newline><^END>

start is an NR3 response data type.

Remarks

In the QSCV measurement, the measurement unit executes the capacitance measurement for the sweep steps except for the sweep start voltage and stop voltage. At each sweep step, the capacitance measurement is executed over the voltage range: output voltage \pm capacitance measurement voltage.

The number of sweep steps is calculated from the equation (fractions below decimal point are rounded down): $|start-stop| / |step| - 1$. You must set the start, stop, and step values so that the number of sweep steps value is in the range: 1 to 1001. If the calculation result is 0, the value is automatically set to 1. Then the measurement unit executes a one-point capacitance measurement between the start and stop values.

Example

```
OUTPUT @Hp4155;":PAGE:MEAS:QSCV:VAR1:START 0"
```

```
OUTPUT @Hp4155;":PAGE:MEAS:QSCV:VAR1:STAR?"
```

```
ENTER @Hp4155;A
```

See Also

:PAGE:MEASure:QSCV:VAR1:CSTEp

:PAGE:MEASure:QSCV:VAR1:STEP

This command sets the VAR1 sweep step value for Quasi-static CV measurements. This command also has a query form.

At *RST, this value is set to 0.1.

Syntax :PAGE:MEASure:QSCV:VAR1:STEP *step* | MINimum | MAXimum
:PAGE:MEASure:QSCV:VAR1:STEP?

Parameter

Parameter	Type	Explanation
<i>step</i>	numeric	VAR1 sweep step value. -400 to 400 V. The range of this value depends on the type of VAR1 unit being used. The minimum value is double the resolution value of the output range.

Query response *step* <newline><^END>
step is an NR3 response data type.

Remarks In the QSCV measurement, the measurement unit executes the capacitance measurement for the sweep steps except for the sweep start voltage and stop voltage. At each sweep step, the capacitance measurement is executed over the voltage range: output voltage ± capacitance measurement voltage.

The number of sweep steps is calculated from the equation (fractions below decimal point are rounded down): $|start-stop| / |step| - 1$. You must set the start, stop, and step values so that the number of sweep steps value is in the range: 1 to 1001. If the calculation result is 0, the value is automatically set to 1. Then the measurement unit executes a one-point capacitance measurement between the start and stop values.

Example OUTPUT @Hp4155;":PAGE:MEAS:QSCV:VAR1:STEP 0.1"
OUTPUT @Hp4155;":PAGE:MEAS:QSCV:VAR1:STEP?"
ENTER @Hp4155;A

See Also :PAGE:MEASure:QSCV:VAR1:CSTEp

SCPI Commands
:PAGE:MEASure:QSCV:VAR1:STOP

:PAGE:MEASure:QSCV:VAR1:STOP

This command sets the VAR1 sweep stop value for Quasi-static CV measurements. This value is the upper or lower limit of the sweep output. This command also has a query form.

At *RST, this value is set to 1.

Syntax

:PAGE:MEASure:QSCV:VAR1:STOP *stop* | MINimum | MAXimum

:PAGE:MEASure:QSCV:VAR1:STOP?

Parameter

Parameter	Type	Explanation
<i>stop</i>	numeric	VAR1 sweep stop value. -200 to 200 V. The range of this value depends on the type of VAR1 unit being used.

Query response

stop <newline><^END>

stop is an NR3 response data type.

Remarks

In the QSCV measurement, the measurement unit executes the capacitance measurement for the sweep steps except for the sweep start voltage and stop voltage. At each sweep step, the capacitance measurement is executed over the voltage range: output voltage \pm capacitance measurement voltage.

The number of sweep steps is calculated from the equation (fractions below decimal point are rounded down): $|start-stop| / |step| - 1$. You must set the start, stop, and step values so that the number of sweep steps value is in the range: 1 to 1001. If the calculation result is 0, the value is automatically set to 1. Then the measurement unit executes a one-point capacitance measurement between the start and stop values.

Example

```
OUTPUT @Hp4155;":PAGE:MEAS:QSCV:VAR1:STOP 10"
```

```
OUTPUT @Hp4155;":PAGE:MEAS:QSCV:VAR1:STOP?"
```

```
ENTER @Hp4155;A
```

See Also

:PAGE:MEASure:QSCV:VAR1:CSTEp

:PAGE:MEASure:QSCV:ZCANcel

This command enables or disables the offset capacitance cancel mode for Quasi-static CV measurements. This command also has a query form.

At *RST, this value is OFF.

Syntax

:PAGE:MEASure:QSCV:ZCANcel OFF | ON | 0 | 1

:PAGE:MEASure:QSCV:ZCANcel?

Parameter

Parameter	Type	Explanation
OFF or 0	Boolean	Offset capacitance cancel is disabled.
ON or 1	Boolean	Offset capacitance cancel is enabled.

Query response

0 | 1 <newline><^END>

Example

```
OUTPUT @Hp4155;":PAGE:MEAS:QSCV:ZCAN ON"
```

```
OUTPUT @Hp4155;":PAGE:MEAS:QSCV:ZCAN?"
```

```
ENTER @Hp4155;A
```

SCPI Commands

:PAGE:MEASure:SAMPLing:CONStant:SMU<n>:COMPLiance

:PAGE:MEASure:SAMPLing:CONStant:SMU<n>:COMPLiance

This command sets the constant COMPLIANCE value of SMU<n> for the sampling measurement.

<n> is required to specify SMU number. Valid SMU numbers are SMU1 through SMU6, depending on the configuration.

The mode of the specified SMU must be V or I.

Syntax

:PAGE:MEASure:SAMPLing:CONStant:SMU<n>:COMPLiance *compliance* | MINimum | MAXimum

Parameter

Parameter	Type	Explanation
<i>compliance</i>	numeric	-200 to 200 V or -1 to 1 A. The range of this value depends on the type of SMU.

Query response

compliance <newline><^END>

compliance is NR3 response data type.

Example

```
OUTPUT @Hp4155;":PAGE:MEAS:SAMP:CONS:SMU1:COMP 0.1"  
OUTPUT @Hp4155;":PAGE:MEAS:SAMP:CONS:SMU1:COMP MAX"  
OUTPUT @Hp4155;":PAGE:MEAS:SAMP:CONS:SMU1:COMP?"  
ENTER @Hp4155;A  
OUTPUT @Hp4155;":PAGE:MEAS:SAMP:CONS:SMU1:COMP? MAX"  
ENTER @Hp4155;A
```

:PAGE:MEASure:SAMPLing:CONStant:SMU<n>[:SOURce]

:PAGE:MEASure:SAMPLing:CONStant:SMU<n>[:SOURce]

This command sets the constant SOURCE value of SMU<n> for the sampling measurement.

<n> is required to specify SMU number. Valid SMU numbers are SMU1 through SMU6, depending on the configuration.

The mode of the specified SMU must be V or I.

Syntax

```
:PAGE:MEASure:SAMPLing:CONStant:SMU<n> [:SOURce] source | MINimum | MAXimum
```

Parameter

Parameter	Type	Explanation
<i>source</i>	numeric	-200 to 200 V or -1 to 1 A. The range of this value depends on the type of SMU.

Query response

```
source <newline><^END>
```

source is NR3 response data type.

Example

```
OUTPUT @Hp4155;":PAGE:MEAS:SAMP:CONS:SMU1 10"
OUTPUT @Hp4155;":PAGE:MEAS:SAMP:CONS:SMU1 MAX"
OUTPUT @Hp4155;":PAGE:MEAS:SAMP:CONS:SMU1?"
ENTER @Hp4155;A
OUTPUT @Hp4155;":PAGE:MEAS:SAMP:CONS:SMU1? MAX"
ENTER @Hp4155;A
```

SCPI Commands

:PAGE:MEASure:SAMPLing:CONStant:VSU<n>[:SOURce]

:PAGE:MEASure:SAMPLing:CONStant:VSU<n>[:SOURce]

This command sets the constant SOURCE value of VSU<n> for the sampling measurement.

<n> is required to specify VSU number. Valid VSU numbers are VSU1 through VSU2.

The specified VSU must not be DISable.

Syntax

:PAGE:MEASure:SAMPLing:CONStant:VSU<n> [:SOURce] *source* | MINimum | MAXimum

Parameter

Parameter	Type	Explanation
<i>source</i>	numeric	-20 V to 20 V

Query response

source <newline><^END>

source is NR3 response data type.

Example

```
OUTPUT @Hp4155;":PAGE:MEAS:SAMP:CONS:VSU1 10"  
OUTPUT @Hp4155;":PAGE:MEAS:SAMP:CONS:VSU1 MAX"  
OUTPUT @Hp4155;":PAGE:MEAS:SAMP:CONS:VSU1?"  
ENTER @Hp4155;A  
OUTPUT @Hp4155;":PAGE:MEAS:SAMP:CONS:VSU1? MAX"  
ENTER @Hp4155;A
```

:PAGE:MEASure:SAMPLing:FILTer

This command sets the SMU output filter state for sampling measurement.

Syntax

:PAGE:MEASure:SAMPLing:FILTer OFF | ON | 0 | 1

Parameter

Parameter	Type	Explanation
OFF or 0	boolean	Filter off
ON or 1	boolean	Filter on

Query response

0 | 1 <newline><<^END>

Example

```
OUTPUT @Hp4155;":PAGE:MEASure:SAMPLing:FILT ON"
OUTPUT @Hp4155;":PAGE:MEASure:SAMPLing:FILT?"
ENTER @Hp4155;A
```

:PAGE:MEASure:SAMPLing:HTIME

This command sets the HOLD TIME of sampling measurement.

Syntax

:PAGE:MEASure:SAMPLing:HTIME *hold_time* | MINimum | MAXimum

Parameter

Parameter	Type	Explanation
<i>hold_time</i>	numeric	3E-2 to 655.35 (s). Resolution: 100 μ s

Query response

hold_time <newline><<^END>

hold_time is NR3 response data type.

Example

```
OUTPUT @Hp4155;":PAGE:MEAS:SAMP:HTIM 1.5"
OUTPUT @Hp4155;":PAGE:MEAS:SAMP:HTIM MAX"
OUTPUT @Hp4155;":PAGE:MEAS:SAMP:HTIM?"
ENTER @Hp4155;A

OUTPUT @Hp4155;":PAGE:MEAS:SAMP:HTIM? MAX"
ENTER @Hp4155;A
```

SCPI Commands
:PAGE:MEASure:SAMPLing:IINterval

:PAGE:MEASure:SAMPLing:IINterval

This command sets the INITIAL INTERVAL for sampling measurement.

Syntax :PAGE:MEASure:SAMPLing:IINterval *initial_interval* | MINimum | MAXimum

Parameter

Parameter	Type	Explanation
<i>initial_interval</i>	numeric	60E-6 to 65.535 (s)

Query response *initial_interval* <newline><^END>

initial_interval is NR3 response data type.

Example

```
OUTPUT @Hp4155;":PAGE:MEAS:SAMP:IINT 0.5"  
OUTPUT @Hp4155;":PAGE:MEAS:SAMP:IINT MIN"  
OUTPUT @Hp4155;":PAGE:MEAS:SAMP:IINT?"  
ENTER @Hp4155;A  
OUTPUT @Hp4155;":PAGE:MEAS:SAMP:IINT? MIN"  
ENTER @Hp4155;A
```

:PAGE:MEASure:SAMPLing[:MENU]

This command changes the present display page to MEASURE: SAMPLING SETUP page.

This command does not have query form.

Syntax :PAGE:MEASure:SAMPLing [:MENU]

Example OUTPUT @Hp4155;":PAGE:MEAS:SAMP"

:PAGE:MEASure:SAMPLing:MODE

This command sets the MODE for sampling measurement.

The sampling mode determines the sampling interval.

Syntax :PAGE:MEASure:SAMPLing:MODE LINear | L10 | L25 | L50 | THINnedout

Parameter

Parameter	Type	Explanation
LINear	character	linear sampling mode
L10	character	logarithmic sampling (10 points per decade)
L25	character	logarithmic sampling (25 points per decade)
L50	character	logarithmic sampling (50 points per decade)
THINnedout	character	thinned-out sampling mode

Query response

LIN | L10 | L25 | L50 | THIN <newline><^END>

Example

```
OUTPUT @Hp4155;":PAGE:MEAS:SAMP:MODE LIN"
OUTPUT @Hp4155;":PAGE:MEAS:SAMP:MODE?"
ENTER @Hp4155;A$
```

:PAGE:MEASure:SAMPling:PERiod

This command sets the TOTAL SAMPLING TIME for sampling measurement. This command is available for LINear and THINnedout mode.

Syntax

:PAGE:MEASure:SAMPling:PERiod *total_samp_time* | INFIinity | MINimum | MAXimum

Parameter

Parameter	Type	Explanation
<i>total_samp_time</i>	numeric	60E-6 to 1E11 (s). minimum: <i>initial_interval</i> × (<i>no_of_samples</i> −1)
INFIinity	character	no limit (disables total sampling time and number of samples stop events.)

Query response

total_samp_time <newline><^END>

total_samp_time is NR3 response data type.

Example

```
OUTPUT @Hp4155;":PAGE:MEAS:SAMP:PER 10"
OUTPUT @Hp4155;":PAGE:MEAS:SAMP:PER?"
ENTER @Hp4155;A
```

SCPI Commands

:PAGE:MEASure:SAMPLing:PERiod:AUTO

:PAGE:MEASure:SAMPLing:PERiod:AUTO

This command sets the TOTAL SAMPLING TIME for sampling measurement. This command is available only for LINear mode.

If you set :PAGE:MEAS:SAMP:PER *total_samp_time*, then AUTO OFF is set.

Syntax

:PAGE:MEASure:SAMPLing:PERiod:AUTO OFF | ON | 0 | 1

Parameter

Parameter	Type	Explanation
OFF or 0	boolean	:PAGE:MEAS:SAMP:PER setting is effective.
ON or 1	boolean	auto (disables total sampling time stop event, and enables the number of samples stop event.)

Query response

0 | 1 <newline><^END>

Example

```
OUTPUT @Hp4155;":PAGE:MEAS:SAMP:PER:AUTO ON"  
OUTPUT @Hp4155;":PAGE:MEAS:SAMP:PER:AUTO?"  
ENTER @Hp4155;A
```

:PAGE:MEASure:SAMPLing:POINTs

This command sets the NUMBER OF SAMPLES for sampling measurement.

Syntax

:PAGE:MEASure:SAMPLing:POINTs *no_of_samples* | MINimum | MAXimum

Parameter

Parameter	Type	Explanation
<i>no_of_samples</i>	numeric	1 to 10001

Query response

no_of_samples <newline><^END>

no_of_samples is NR1 response data type.

Example

```

OUTPUT @Hp4155;":PAGE:MEAS:SAMP:POIN 5"
OUTPUT @Hp4155;":PAGE:MEAS:SAMP:POIN MAX"
OUTPUT @Hp4155;":PAGE:MEAS:SAMP:POIN?"
ENTER @Hp4155;A
OUTPUT @Hp4155;":PAGE:MEAS:SAMP:POIN? MAX"
ENTER @Hp4155;A

```

:PAGE:MEASure:SAMPing:SCONdition:ECOunt

This command sets the number of **EVENT** occurrences for the stop condition.

Sampling measurement continues until **EVENT** occurs the specified number of times (*event_number*).

Syntax

```
:PAGE:MEASure:SAMPing:SCONdition:ECOunt event_number | MINimum |
MAXimum
```

Parameter

Parameter	Type	Explanation
<i>event_number</i>	numeric	1 to 200

Query response

```
event_number <newline><^END>
```

event_number is NR1 response data type.

Example

```

OUTPUT @Hp4155;":PAGE:MEAS:SAMP:SCON:ECO 10"
OUTPUT @Hp4155;":PAGE:MEAS:SAMP:SCON:ECO?"
ENTER @Hp4155;A

```

:PAGE:MEASure:SAMPLing:SCONdition:EDELay

This command sets the ENABLE DELAY time for the stop condition of sampling measurement.

Syntax

:PAGE:MEASure:SAMPLing:SCONdition:EDELay *enable_delay* | MINimum | MAXimum

Parameter

Parameter	Type	Explanation
<i>enable_delay</i>	numeric	0 to (<i>initial_interval</i> × 32767)

Query response

enable_delay <newline><^END>

enable_delay is NR3 response data type.

Example

OUTPUT @Hp4155;":PAGE:MEAS:SAMP:SCON:EDEL 1.0"

OUTPUT @Hp4155;":PAGE:MEAS:SAMP:SCON:EDEL MAX"

OUTPUT @Hp4155;":PAGE:MEAS:SAMP:SCON:EDEL?"
ENTER @Hp4155;A

OUTPUT @Hp4155;":PAGE:MEAS:SAMP:SCON:EDEL? MAX"
ENTER @Hp4155;A

:PAGE:MEASure:SAMPLing:SCONdition:EVENT

This command sets the EVENT to use with the NAME and THRESHOLD to define the stop condition of sampling measurement.

EVENT describes the relation between THRESHOLD and the value of the NAME variable.

Syntax

:PAGE:MEASure:SAMPLing:SCONdition:EVENT LOW | HIGH | ABSLow | ABSHigh

Parameter

Parameter	Type	Explanation
LOW	character	NAME <i>value</i> < THReshold
HIGH	character	NAME <i>value</i> > THReshold
ABSLow	character	NAME <i>value</i> < THReshold
ABSHigh	character	NAME <i>value</i> > THReshold

Query response LOW | HIGH | ABSL | ABSH <newline><^END>

Example OUTPUT @Hp4155;":PAGE:MEAS:SAMP:SCON:EVENT HIGH"
 OUTPUT @Hp4155;":PAGE:MEAS:SAMP:SCON:EVENT?"
 ENTER @Hp4155;A\$

:PAGE:MEASure:SAMPLing:SCONdition:NAME

This command selects the variable NAME to use with the THReshold and EVENT to define the stop condition of sampling measurement.

Syntax :PAGE:MEASure:SAMPLing:SCONdition:NAME *var_name*

Parameter

Parameter	Type	Explanation
<i>var_name</i>	string	data variable name

Query response *var_name* <newline><^END>

var_name is string response data, but does not contain double quote characters at the beginning and end of the string.

Example OUTPUT @Hp4155;":PAGE:MEAS:SAMP:SCON:NAME 'VD'"
 OUTPUT @Hp4155;":PAGE:MEAS:SAMP:SCON:NAME?"
 ENTER @Hp4155;A\$

SCPI Commands

:PAGE:MEASure:SAMPLing:SCONdition[:STATe]

:PAGE:MEASure:SAMPLing:SCONdition[:STATe]

This command controls whether the sampling stop condition is enabled.

Syntax

:PAGE:MEASure:SAMPLing:SCONdition [:STATe] OFF | ON | 0 | 1

Parameter

Parameter	Type	Explanation
OFF or 0	boolean	stop condition is disabled
ON or 1	boolean	stop condition is enabled

Query response

0 | 1 <newline><<^END>

Example

```
OUTPUT @Hp4155;":PAGE:MEAS:SAMP:SCON ON"  
OUTPUT @Hp4155;":PAGE:MEAS:SAMP:SCON?"  
ENTER @Hp4155;A
```

:PAGE:MEASure:SAMPLing:SCONdition:THReshold

This command sets the THReshold value to use with the NAME and EVENT to define the stop condition of sampling measurement.

Syntax

:PAGE:MEASure:SAMPLing:SCONdition:THReshold *threshold* | MINimum | MAXimum

Parameter

Parameter	Type	Explanation
<i>threshold</i>	numeric	threshold value to define the stop condition of sampling measurement.

Query response

threshold <newline><<^END>

threshold is NR3 response data type.

Example

```
OUTPUT @Hp4155;":PAGE:MEAS:SAMP:SCON:THR 0.5"  
OUTPUT @Hp4155;":PAGE:MEAS:SAMP:SCON:THR?"  
ENTER @Hp4155;A
```

:PAGE:MEASure[:SWEep]:CONStant:SMU<n>:COMPLiance

:PAGE:MEASure[:SWEep]:CONStant:SMU<n>:COMPLiance

This command sets the constant COMPLIANCE value of SMU<n> for the sweep measurement.

<n> is required to specify SMU number. Valid SMU numbers are SMU1 through SMU6, depending on the configuration.

You use this command only if the function of the specified SMU is CONStant and the mode is not COMMon.

At *RST, this value is:

SMU	COMPLIANCE
SMU1	not defined
SMU2	2 V
SMU3	100 mA
SMU4	100 mA
SMU5 and SMU6	not defined

Syntax

:PAGE:MEASure [:SWEep] :CONStant:SMU<n>:COMPLiance *compliance* | MINimum | MAXimum

Parameter

Parameter	Type	Explanation
<i>compliance</i>	numeric	-200 to 200 V or -1 to 1 A. The range of this value depends on the type of SMU.

Query response

compliance <newline><^END>

compliance is NR3 response data type.

Example

```
OUTPUT @Hp4155;":PAGE:MEAS:CONS:SMU1:COMP 0.1"
OUTPUT @Hp4155;":PAGE:MEAS:CONS:SMU1:COMP MAX"
OUTPUT @Hp4155;":PAGE:MEAS:CONS:SMU1:COMP?"
ENTER @Hp4155;A
OUTPUT @Hp4155;":PAGE:MEAS:CONS:SMU1:COMP? MAX"
ENTER @Hp4155;A
```

SCPI Commands

:PAGE:MEASure[:SWEep]:CONStant:SMU<n>[:SOURce]

:PAGE:MEASure[:SWEep]:CONStant:SMU<n>[:SOURce]

This command sets the constant SOURCE value of SMU<n> for the sweep measurement.

<n> is required to specify SMU number. Valid SMU numbers are SMU1 through SMU6, depending on the configuration.

You use this command only if the function of the specified SMU is **CONStant** and the mode is not **COMMon**.

At *RST, this value is 0 V.

Syntax

:PAGE:MEASure [:SWEep] :CONStant:SMU<n> [:SOURce] *source* | MINimum | MAXimum

Parameter

Parameter	Type	Explanation
<i>source</i>	numeric	-200 to 200 V or -1 to 1 A. The range of this value depends on the type of SMU.

Query response

source <newline><^END>

source is NR3 response data type.

Example

```
OUTPUT @Hp4155;":PAGE:MEAS:CONS:SMU1 10"  
OUTPUT @Hp4155;":PAGE:MEAS:CONS:SMU1 MAX"  
OUTPUT @Hp4155;":PAGE:MEAS:CONS:SMU1?"  
ENTER @Hp4155;A  
OUTPUT @Hp4155;":PAGE:MEAS:CONS:SMU1? MAX"  
ENTER @Hp4155;A
```

:PAGE:MEASure[:SWEep]:CONStant:VSU<n>[:SOURce]

:PAGE:MEASure[:SWEep]:CONStant:VSU<n>[:SOURce]

This command sets the constant SOURCE value of VSU<n> for the sweep measurement.

<n> is required to specify VSU number. Valid VSU numbers are VSU1 through VSU2.

You use this command only if the function of the specified VSU is CONStant.

At *RST, this value is 0V.

Syntax

:PAGE:MEASure [:SWEep] :CONStant:VSU<n> [:SOURce] *source* | MINimum | MAXimum

Parameter

Parameter	Type	Explanation
<i>source</i>	numeric	-20 to 20 V

Query response

source <newline><^END>

source is NR3 response data type.

Example

```
OUTPUT @Hp4155; ":PAGE:MEAS:CONS:VSU1 10"
```

```
OUTPUT @Hp4155; ":PAGE:MEAS:CONS:VSU1 MAX"
```

```
OUTPUT @Hp4155; ":PAGE:MEAS:CONS:VSU1?"
```

```
ENTER @Hp4155;A
```

```
OUTPUT @Hp4155; ":PAGE:MEAS:CONS:VSU1? MAX"
```

```
ENTER @Hp4155;A
```

SCPI Commands

:PAGE:MEASure[:SWEep]:DELay

:PAGE:MEASure[:SWEep]:DELay

This command sets the DELAY TIME of SMU.

At *RST, this value is 0.

Syntax

:PAGE:MEASure [:SWEep] :DELay *delay_time* | MINimum | MAXimum

Parameter

Parameter	Type	Explanation
<i>delay_time</i>	numeric	0 to 65.535 (s). Resolution: 100 μ s.

Query response

delay_time <newline><^END>

delay_time is NR3 response data type.

Example

```
OUTPUT @Hp4155;":PAGE:MEAS:DEL 1.5"
```

```
OUTPUT @Hp4155;":PAGE:MEAS:DEL MIN"
```

```
OUTPUT @Hp4155;":PAGE:MEAS:DEL?"
```

```
ENTER @Hp4155;A
```

```
OUTPUT @Hp4155;":PAGE:MEAS:DEL? MAX"
```

```
ENTER @Hp4155;A
```

:PAGE:MEASure[:SWEep]:HTIME

This command sets the HOLD TIME of sweep measurement.

At *RST, this value is 0.

Syntax

:PAGE:MEASure [:SWEep] :HTIME *hold_time* | MINimum | MAXimum

Parameter

Parameter	Type	Explanation
<i>hold_time</i>	numeric	0 to 655.35 (s). Resolution: 10 ms.

Query response

hold_time <newline><^END>

hold_time is NR3 response data type.

Example

```
OUTPUT @Hp4155;":PAGE:MEAS:HTIM 1.5"
```



```
OUTPUT @Hp4155;":PAGE:MEAS:HTIM?"
ENTER @Hp4155;A
```

:PAGE:MEASure[:SWEep][:MENU]

This command changes the present display page to MEASure: SWEEP SETUP.

This command does not have query form.

Syntax

```
:PAGE:MEASure [ :SWEep] [ :MENU]
```

Example

```
OUTPUT @Hp4155;":PAGE:MEAS:SWE"
```

:PAGE:MEASure[:SWEep]:PULSe:BASE

This command sets the pulse BASE of SMU.

You use this command only if an SMU is set to VPULse or IPULse mode.

Syntax

```
:PAGE:MEASure [ :SWEep] :PULSe:BASE base | MINimum | MAXimum
```

Parameter

Parameter	Type	Explanation
<i>base</i>	numeric	-200 to 200 V or -1 to 1 A. The range of this value depends on the type of SMU.

Query response

```
base <newline><^END>
```

base is NR3 response data type.

Example

```
OUTPUT @Hp4155;":PAGE:MEAS:PULS:BASE 1.5"
OUTPUT @Hp4155;":PAGE:MEAS:PULS:BASE MIN"
OUTPUT @Hp4155;":PAGE:MEAS:PULS:BASE?"
ENTER @Hp4155;A
OUTPUT @Hp4155;":PAGE:MEAS:PULS:BASE? MIN"
ENTER @Hp4155;A
```

SCPI Commands

:PAGE:MEASure[:SWEep]:PULSe:PERiod

:PAGE:MEASure[:SWEep]:PULSe:PERiod

This command sets the pulse PERIOD of SMU.

You use this command only if an SMU is set to VPULse or IPULse mode.

Syntax

:PAGE:MEASure [:SWEep] :PULSe:PERiod *period* | MINimum | MAXimum

Parameter

Parameter	Type	Explanation
<i>period</i>	numeric	5E-3 to 1 (s). Resolution: 100 μ s.

Query response

period <newline><^END>

period is NR3 response data type.

Example

```
OUTPUT @Hp4155;":PAGE:MEAS:PULS:PER 0.1"
OUTPUT @Hp4155;":PAGE:MEAS:PULS:PER MAX"
OUTPUT @Hp4155;":PAGE:MEAS:PULS:PER?"
ENTER @Hp4155;A
OUTPUT @Hp4155;":PAGE:MEAS:PULS:PER? MAX"
ENTER @Hp4155;A
```

:PAGE:MEASure[:SWEep]:PULSe:WIDTh

This command sets the pulse WIDTH of SMU.

You use this command only if an SMU is set to VPULse or IPULse mode.

Syntax

:PAGE:MEASure [:SWEep] :PULSe:WIDTh *width* | MINimum | MAXimum

Parameter

Parameter	Type	Explanation
<i>width</i>	numeric	5E-4 to 1E-1 (s). Resolution: 100 μ s.

Query response

width <newline><^END>

width is NR3 response data type.

Example

```
OUTPUT @Hp4155;":PAGE:MEAS:PULS:WIDTH 0.1"
```

```
OUTPUT @Hp4155;":PAGE:MEAS:PULS:WIDTH MAX"
OUTPUT @Hp4155;":PAGE:MEAS:PULS:WIDTH?"
ENTER @Hp4155;A

OUTPUT @Hp4155;":PAGE:MEAS:PULS:WIDTH? MAX"
ENTER @Hp4155;A
```

:PAGE:MEASure[:SWEep]:SSTop

This command sets the sweep stop mode for an abnormal status.

The abnormal statuses that can be detected are as follows:

- SMU reaches its compliance setting.
- Current of VSU exceeds ± 100 mA.
- SMU or VSU oscillates.
- A/D converter overflow occurs.
- Average current of PGU exceeds ± 100 mA.

At *RST, this value is OFF.

If you set the SERIES RESISTANCE of SMU<n> to a non-zero value by :PAGE:CHANnels[:CDEFinition]:SMU<n>:SRESistance, this value is automatically changed to COMP.

Syntax

:PAGE:MEASure [:SWEep] :SSTop ABNormal | COMPLIance | OFF

Parameter

Parameter	Type	Explanation
ABNormal	character	Stop sweep if abnormal status is detected.
COMPLIance	character	Stop sweep if some SMU reaches its compliance setting.
OFF	character	Continue sweep even if abnormal status is detected.

If you set the power compliance for VAR1, you cannot specify OFF.

Query response

OFF | ABN | COMP <newline><^END>

Example

```
OUTPUT @Hp4155;":PAGE:MEAS:SST ABN"
OUTPUT @Hp4155;":PAGE:MEAS:SST?"
ENTER @Hp4155;A$
```

SCPI Commands
:PAGE:MEASure[:SWEep]:VAR1:COMpliance

:PAGE:MEASure[:SWEep]:VAR1:COMpliance

This command sets the COMPLIANCE value of VAR1.

If the unit type of VAR1 is VSU, this parameter is ignored.

At *RST, this value is 100 mA.

Syntax :PAGE:MEASure [:SWEep] :VAR1:COMpliance *compliance* | MINimum | MAXimum

Parameter

Parameter	Type	Explanation
<i>compliance</i>	numeric	-200 V to 200V or -1 A to 1 A. The range of this value depends on the unit type of VAR1.

Query response *compliance* <newline><^END>

compliance is NR3 response data type.

Example

```
OUTPUT @Hp4155;":PAGE:MEAS:VAR1:COMP 0.1"  
OUTPUT @Hp4155;":PAGE:MEAS:VAR1:COMP MAX"  
OUTPUT @Hp4155;":PAGE:MEAS:VAR1:COMP?"  
ENTER @Hp4155;A  
OUTPUT @Hp4155;":PAGE:MEAS:VAR1:COMP? MAX"  
ENTER @Hp4155;A
```

:PAGE:MEASure[:SWEep]:VAR1:MODE

This command sets the SWEEP MODE of VAR1 for normal (not knob) sweep measurement. At *RST, this value is SINGLE.

Syntax :PAGE:MEASure [:SWEep] :VAR1:MODE SINGLE | DOUBLE

Parameter

Parameter	Type	Explanation
SINGLE	character	single stair sweep
DOUBLE	character	double stair sweep

Query response SING | DOUB <newline><^END>

Example
 OUTPUT @Hp4155;":PAGE:MEAS:VAR1:MODE SINGLE"
 OUTPUT @Hp4155;":PAGE:MEAS:VAR1:MODE?"
 ENTER @Hp4155;A\$

:PAGE:MEASure[:SWEep]:VAR1:PCOMpliance

This command sets the power compliance value of VAR1.

If the unit type of VAR1 is VSU, this parameter is ignored.

At *RST, this value is not defined, but the PCOMpliance:STATe is OFF.

Syntax :PAGE:MEASure [:SWEep] :VAR1:PCOMpliance *pcompliance* | MINimum | MAXimum

Parameter

Parameter	Type	Explanation
<i>pcompliance</i>	numeric	1E-3 to 20. The range of this value depends on the unit type of VAR1.

If SMU for VAR1 unit is set to VPULSE or IPULSE mode, you *cannot* set power compliance for VAR1 unit.

Query response *pcompliance* <newline><^END>

pcompliance is NR3 response data type.

Example
 OUTPUT @Hp4155;":PAGE:MEAS:VAR1:PCOM 0.5"
 OUTPUT @Hp4155;":PAGE:MEAS:VAR1:PCOM MAX"
 OUTPUT @Hp4155;":PAGE:MEAS:VAR1:PCOM?"
 ENTER @Hp4155;A
 OUTPUT @Hp4155;":PAGE:MEAS:VAR1:PCOM? MAX"
 ENTER @Hp4155;A

SCPI Commands

:PAGE:MEASure[:SWEep]:VAR1:PCOMpliance:STATe

:PAGE:MEASure[:SWEep]:VAR1:PCOMpliance:STATe

This command sets the power compliance of VAR1 to disable.

If SMU for VAR1 unit is set to VPULse or IPULse mode, STATe is set to OFF. You cannot set power compliance for VAR1.

If the unit type of VAR1 is VSU, STATe is ignored.

If power compliance value is set by PCOMpliance *power compliance*, the query returns 1.

At *RST, this value is OFF.

Syntax

:PAGE:MEASure [:SWEep] :VAR1:PCOMpliance:STATe OFF | 0

Parameter

Parameter	Type	Explanation
OFF or 0	boolean	power compliance is disabled

Query response

0 | 1 <newline><^END>

Example

```
OUTPUT @Hp4155;":PAGE:MEAS:VAR1:PCOM:STATE OFF"
OUTPUT @Hp4155;":PAGE:MEAS:VAR1:PCOM:STATE?"
ENTER @Hp4155;A
```

:PAGE:MEASure[:SWEep]:VAR1:SPACing

This command selects the sweep type of VAR1: linear staircase or logarithmic staircase.

At *RST, this value is LINear.

Syntax

:PAGE:MEASure [:SWEep] :VAR1:SPACing LINear | L10 | L25 | L50

Parameter

Parameter	Type	Explanation
LINear	character	The sweep is incremented (decremented) by the stepsize until the stop value is reached.
L10	character	The sweep is performed logarithmically (10 steps per decade) between the stop and start values.
L25	character	The sweep is performed logarithmically (25 steps per decade) between the stop and start values.
L50	character	The sweep is performed logarithmically (50 steps per decade) between the stop and start values.

Query response

LIN | L10 | L25 | L50 <newline><^END>

Example

```
OUTPUT @Hp4155;":PAGE:MEAS:VAR1:SPAC LIN"
OUTPUT @Hp4155;":PAGE:MEAS:VAR1:SPAC?"
ENTER @Hp4155;A$
```

SCPI Commands

:PAGE:MEASure[:SWEep]:VAR1:START

:PAGE:MEASure[:SWEep]:VAR1:START

This command sets the sweep START value of VAR1.

At *RST, this value is 0 V.

Syntax

:PAGE:MEASure [:SWEep] :VAR1:START *start* | MINimum | MAXimum

Parameter

Parameter	Type	Explanation
<i>start</i>	numeric	-200 to 200 V or -1 to 1 A. The range of this value depends on the unit type of VAR1.

Query response

start <newline><^END>

start is NR3 response data type.

Example

```
OUTPUT @Hp4155;":PAGE:MEAS:VAR1:START 0"
OUTPUT @Hp4155;":PAGE:MEAS:VAR1:START MIN"
OUTPUT @Hp4155;":PAGE:MEAS:VAR1:START?"
ENTER @Hp4155;A
OUTPUT @Hp4155;":PAGE:MEAS:VAR1:START? MIN"
ENTER @Hp4155;A
```

:PAGE:MEASure[:SWEep]:VAR1:STEP

This command sets the sweep STEP value of VAR1 for the linear sweep. This parameter is not used for logarithmic sweep.

At *RST, this value is 0.01 V.

Syntax

:PAGE:MEASure [:SWEep] :VAR1:STEP *step* | MINimum | MAXimum

Parameter

Parameter	Type	Explanation
<i>step</i>	numeric	-400 to 400 V or -2 to 2 A. The range of this value depends on the unit type of VAR1.

The polarity of step value is automatically determined by the relation between start and stop values. So, for the step value you specify, only absolute value has meaning. The polarity has no meaning.

Query response *step* <newline><^END>

step is NR3 response data type.

Example
 OUTPUT @Hp4155;":PAGE:MEAS:VAR1:STEP 0.01"
 OUTPUT @Hp4155;":PAGE:MEAS:VAR1:STEP?"
 ENTER @Hp4155;A

:PAGE:MEASure[:SWEep]:VAR1:STOP

This command sets the sweep STOP value of VAR1.

At *RST, this value is 1 V.

Syntax :PAGE:MEASure [:SWEep] :VAR1:STOP *stop* | MINimum | MAXimum

Parameter

Parameter	Type	Explanation
<i>stop</i>	numeric	-200 to 200 V or -1 to 1 A. The range of this value depends on the unit type of VAR1.

Query response *stop* <newline><^END>

stop is NR3 response data type.

Example
 OUTPUT @Hp4155;":PAGE:MEAS:VAR1:STOP 1"
 OUTPUT @Hp4155;":PAGE:MEAS:VAR1:STOP MAX"
 OUTPUT @Hp4155;":PAGE:MEAS:VAR1:STOP?"
 ENTER @Hp4155;A
 OUTPUT @Hp4155;":PAGE:MEAS:VAR1:STOP? MAX"
 ENTER @Hp4155;A

SCPI Commands
:PAGE:MEASure[:SWEep]:VAR2:COMPLIance

:PAGE:MEASure[:SWEep]:VAR2:COMPLIance

This command sets the COMPLIANCE value of VAR2.

You use this command only if there is an SMU whose function (FCTN) is VAR2.

If the unit type of VAR2 is VSU, this parameter is ignored.

At *RST, this value is 2 V.

Syntax :PAGE:MEASure [:SWEep] :VAR2:COMPLIance *compliance* | MINimum | MAXimum

Parameter

Parameter	Type	Explanation
<i>compliance</i>	numeric	-200 to 200 V or -1 to 1 A. The range of this value depends on SMU type of VAR2.

Query response *compliance* <newline><^END>

compliance is NR3 response data type.

Example

```
OUTPUT @Hp4155;":PAGE:MEAS:VAR2:COMP 2"  
OUTPUT @Hp4155;":PAGE:MEAS:VAR2:COMP MAX"  
OUTPUT @Hp4155;":PAGE:MEAS:VAR2:COMP?"  
ENTER @Hp4155;A  
OUTPUT @Hp4155;":PAGE:MEAS:VAR2:COMP? MAX"  
ENTER @Hp4155;A
```

:PAGE:MEASure[:SWEep]:VAR2:PCOMPLIance

This command sets the power compliance value of VAR2.

You use this command only if there is an SMU whose function (FCTN) is VAR2.

If the unit type of VAR2 is VSU, this parameter is ignored.

At *RST, this value is not defined, but the PCOMpliance:STATe is OFF.

Syntax :PAGE:MEASure [:SWEep] :VAR2:PCOMPLIance *pcompliance* | MINimum | MAXimum

Parameter

Parameter	Type	Explanation
<i>pcompliance</i>	numeric	1E-3 to 20. The range of this value depends on SMU type of VAR2.

Query response *pcompliance* <newline><^END>

pcompliance is NR3 response data type.

Example

```
OUTPUT @Hp4155;":PAGE:MEAS:VAR2:PCOM 0.5"
OUTPUT @Hp4155;":PAGE:MEAS:VAR2:PCOM MAX"
OUTPUT @Hp4155;":PAGE:MEAS:VAR2:PCOM?"
ENTER @Hp4155;A
OUTPUT @Hp4155;":PAGE:MEAS:VAR2:PCOM? MAX"
ENTER @Hp4155;A
```

:PAGE:MEASure[:SWEep]:VAR2:PCOMpliance:STATe

This command sets the power compliance of VAR2 to disable.

You use this command only if there is an SMU whose function (FCTN) is VAR2.

If the unit type of VAR2 is VSU, this parameter is ignored.

If power compliance value is set by PCOMpliance *pcompliance*, the query returns 1.

At *RST, this value is OFF.

Syntax :PAGE:MEASure [:SWEep] :VAR2:PCOMpliance:STATe OFF | 0

Parameter

Parameter	Type	Explanation
OFF or 0	boolean	power compliance is disabled

Query response 0 | 1 <newline><^END>

Example

```
OUTPUT @Hp4155;":PAGE:MEAS:VAR2:PCOM:STATE OFF"
OUTPUT @Hp4155;":PAGE:MEAS:VAR2:PCOM:STATE?"
ENTER @Hp4155;A
```

SCPI Commands

:PAGE:MEASure[:SWEep]:VAR2:POINts

:PAGE:MEASure[:SWEep]:VAR2:POINts

This command sets the number of sweep steps of VAR2.

You use this command only if there is an SMU or VSU whose function (FCTN) is VAR2.

At *RST, this value is 5.

Syntax

:PAGE:MEASure [:SWEep] :VAR2:POINts *no_of_steps* | MINimum | MAXimum

Parameter

Parameter	Type	Explanation
<i>no_of_steps</i>	numeric	1 to 128

Query response

no_of_steps <newline><^END>

no_of_steps is NR1 response data type.

Example

```
OUTPUT @Hp4155;":PAGE:MEAS:VAR2:POINTS 5"  
OUTPUT @Hp4155;":PAGE:MEAS:VAR2:POINTS MAX"  
OUTPUT @Hp4155;":PAGE:MEAS:VAR2:POINTS?"  
ENTER @Hp4155;A  
OUTPUT @Hp4155;":PAGE:MEAS:VAR2:POINTS? MAX"  
ENTER @Hp4155;A
```

:PAGE:MEASure[:SWEep]:VAR2:STARt

This command sets the sweep START value of VAR2.

You use this command only if there is an SMU or VSU whose function (FCTN) is VAR2.

At *RST, this value is 20 μ A.

Syntax

:PAGE:MEASure [:SWEep] :VAR2:STARt *start* | MINimum | MAXimum

Parameter

Parameter	Type	Explanation
<i>start</i>	numeric	-200 to 200 V or -1 to 1 A. The range of this value depends on the unit type of VAR2.

Query response *start* <newline><^END>
start is NR3 response data type.

Example

```
OUTPUT @Hp4155;":PAGE:MEAS:VAR2:START 0"
OUTPUT @Hp4155;":PAGE:MEAS:VAR2:START MIN"
OUTPUT @Hp4155;":PAGE:MEAS:VAR2:START?"
ENTER @Hp4155;A
OUTPUT @Hp4155;":PAGE:MEAS:VAR2:START? MAX"
ENTER @Hp4155;A
```

:PAGE:MEASure[:SWEep]:VAR2:STEP

This command sets the sweep STEP value of VAR2.

You use this command only if there is an SMU or VSU whose function (FCTN) is VAR2.

At *RST, this value is 20 μ A.

Syntax :PAGE:MEASure [:SWEep] :VAR2:STEP *step* | MINimum | MAXimum

Parameter

Parameter	Type	Explanation
<i>step</i>	numeric	-400 to 400 V or -2 to 2 A. The range of this value depends on the unit type of VAR2.

Query response *step* <newline><^END>
step is NR3 response data type.

Example

```
OUTPUT @Hp4155;":PAGE:MEAS:VAR2:STEP 20E-6"
OUTPUT @Hp4155;":PAGE:MEAS:VAR2:STEP?"
ENTER @Hp4155;A
```

SCPI Commands
:PAGE:MEASure[:SWEep]:VARD:COMpliance

:PAGE:MEASure[:SWEep]:VARD:COMpliance

This command sets the COMPLIANCE value of VAR1'.

If the unit type of VAR1' is VSU, this parameter is ignored.

You use this command only if there is an SMU whose function (FCTN) is VAR1'.

Syntax

:PAGE:MEASure [:SWEep] :VARD:COMpliance *compliance* | MINimum | MAXimum

Parameter

Parameter	Type	Explanation
<i>compliance</i>	numeric	-200 to 200 V or -1 to 1 A. The range of this value depends on SMU type of VAR1'.

Query response

compliance <newline><^END>

compliance is NR3 response data type.

Example

```
OUTPUT @Hp4155;":PAGE:MEAS:VARD:COMP 2"  
OUTPUT @Hp4155;":PAGE:MEAS:VARD:COMP MAX"  
OUTPUT @Hp4155;":PAGE:MEAS:VARD:COMP?"  
ENTER @Hp4155;A  
OUTPUT @Hp4155;":PAGE:MEAS:VARD:COMP? MAX"  
ENTER @Hp4155;A
```

:PAGE:MEASure[:SWEep]:VARD:OFFSet

This command sets the OFFSET value of VARI'.

For each step of sweep, the output values of VARI' are determined by the following equation:

$$VARI' = VARI \times RATio + OFFSet$$

You use this command only if there is an SMU or VSU whose function (FCTN) is VARI'.

Syntax :PAGE:MEASure [:SWEep] :VARD:OFFSet *offset* | MINimum | MAXimum

Parameter

Parameter	Type	Explanation
<i>offset</i>	numeric	-400 to 400 V or -2 to 2 A. The range of this value depends on the unit type of VARI'.

Query response *offset* <newline><^END>

offset is NR3 response data type.

Example
 OUTPUT @Hp4155;":PAGE:MEAS:VARD:OFFSET 0.5"
 OUTPUT @Hp4155;":PAGE:MEAS:VARD:OFFSET?"
 ENTER @Hp4155;A

See also :PAGE:MEASure[:SWEep]:VARD:RATio

SCPI Commands
:PAGE:MEASure[:SWEep]:VARD:PCOMpliance

:PAGE:MEASure[:SWEep]:VARD:PCOMpliance

This command sets the power compliance value of VARD.

If the unit type of VARD is VSU, this parameter is ignored.

You use this command only if there is an SMU whose function (FCTN) is VAR1'.

Syntax

:PAGE:MEASure [:SWEep] :VARD:PCOMpliance *pcompliance* | MINimum | MAXimum

Parameter

Parameter	Type	Explanation
<i>pcompliance</i>	numeric	1E-3 to 20. The range of this value depends on SMU type of VAR1'.

If SMU for VAR1' unit is set to VPULSE or IPULSE mode, you *cannot* set power compliance for VAR1' unit.

Query response

pcompliance <newline><^END>

pcompliance is NR3 response data type.

Example

```
OUTPUT @Hp4155;":PAGE:MEAS:VARD:PCOM 0.5"  
OUTPUT @Hp4155;":PAGE:MEAS:VARD:PCOM MAX"  
OUTPUT @Hp4155;":PAGE:MEAS:VARD:PCOM?"  
ENTER @Hp4155;A  
OUTPUT @Hp4155;":PAGE:MEAS:VARD:PCOM? MAX"  
ENTER @Hp4155;A
```

:PAGE:MEASure[:SWEep]:VARD:PCOMpliance:STATe

This command sets the power compliance of VARI' to disable.

If SMU for VARI' unit is set to VPULse or IPULse mode, STATe is set to OFF. You cannot set power compliance for VARI'.

If the unit type of VARI' is VSU, this parameter is ignored.

You use this command only if there is an SMU whose function (FCTN) is VARI'.

If power compliance value is set by PCOMpliance *power compliance*, the query returns 1.

At *RST, this value is OFF.

Syntax

:PAGE:MEASure [:SWEep] :VARD:PCOMpliance:STATe OFF | 0

Parameter

Parameter	Type	Explanation
OFF or 0	boolean	power compliance is disabled

Query response

0 | 1 <newline><^END>

Example

```
OUTPUT @Hp4155; ":PAGE:MEAS:VARD:PCOM:STATE OFF"  
OUTPUT @Hp4155; ":PAGE:MEAS:VARD:PCOM:STATE?"  
ENTER @Hp4155;A
```

SCPI Commands

:PAGE:MEASure[:SWEep]:VARD:RATio

:PAGE:MEASure[:SWEep]:VARD:RATio

This command sets the RATIO of VARI'.

For each step of sweep, the output values of VARI' are determined by the following equation:

$$VARI' = VARI \times RATio + OFFSet$$

You use this command only if there is an SMU or VSU whose function (FCTN) is VARI'.

At *RST, this value is not defined.

Syntax

:PAGE:MEASure [:SWEep] :VARD:RATio *ratio* | MINimum | MAXimum

Parameter

Parameter	Type	Explanation
<i>ratio</i>	numeric	ratio of VARI'

Query response

ratio <newline><^END>

ratio is NR3 response data type.

Example

```
OUTPUT @Hp4155;":PAGE:MEAS:VARD:RATIO 0.1"
```

```
OUTPUT @Hp4155;":PAGE:MEAS:VARD:RATIO?"  
ENTER @Hp4155;A
```

See also

:PAGE:MEASure[:SWEep]:VARD:OFFSet

:PAGE:SCON Commands

:PAGE:SCON commands controls the state of the 4155C/4156C, such as measurement, stress forcing, standby, and idle.

Command	Parameter
:PAGE	
:SCONtrol	
:KSweep	
[:START]	
[:MEASurement]	
:APPend	
:REPeat	
:SINGle	
:STANdby	0 1 OFF ON
:STATe?	
:STOP	
:STress	
[:START]	
:TRIGger	
:INPut?	POSitive NEGative EITHER
:OUTPut	
[:PULSe]	POSitive NEGative
:LEVEl	HIGH LOW
:ZERO	

SCPI Commands

:PAGE:SCONtrol:KSWeep[:START]

:PAGE:SCONtrol:KSWeep[:START]

This command enables the start of the Knob SWeep operation.

After this command is executed, you start operation by rotating the front panel knob.

This command changes the present display page to the KNOB SWEEP page.

Executing this command is about the same as pressing Green front-panel key, then pressing Single front-panel key.

This command does not have query form.

Syntax :PAGE:SCONtrol:KSWeep [:START]

Remarks :PAGE:SCON:KSW command is not available when the 4155C/4156C screen is set to the update disable state by :DISP OFF (or 0) command. To use this command, enter :DISP ON (or 1) command.

Example OUTPUT @Hp4155; ":PAGE:SCON:KSW"

:PAGE:SCONtrol[:MEASurement]:APPend

This command starts the APPend measurement operation.

The executed measurement mode, SWEep or SAMPLing, is selected by the :PAGE:CHANnels[:CDEFinition]:MODE command.

This command changes the present display page to the GRAPH/LIST: LIST or GRAPH/LIST: GRAPH page, which is selected by the :PAGE:DISPlay[:SETup]:MODE command.

Executing this command is about the same as pressing Append front-panel key.

This command does not have query form.

Syntax :PAGE:SCONtrol [:MEASurement] :APPend

Example OUTPUT @Hp4155; ":PAGE:SCON:APP"

See also :PAGE:CHANnels[:CDEFinition]:MODE and :PAGE:DISPlay[:SETup]:MODE

:PAGE:SCONtrol[:MEASurement]:REPeat

This command starts the REPeat measurement operation.

The executed measurement mode, SWEEp or SAMPLing, is selected by the :PAGE:CHANnels[:CDEFinition]:MODE command.

This command changes the present display page to the GRAPH/LIST: LIST or GRAPH/LIST: GRAPHICS page, which is selected by the :PAGE:DISPlay[:SETup]:MODE command.

Executing this command is about the same as pressing Repeat front-panel key.

This command does not have query form.

Syntax :PAGE:SCONtrol [:MEASurement] :REPeat

Example OUTPUT @Hp4155; ":PAGE:SCON:REP"

See also :PAGE:CHANnels[:CDEFinition]:MODE and :PAGE:DISPlay[:SETup]:MODE

:PAGE:SCONtrol[:MEASurement]:SINGle

This command starts the SINGle measurement operation.

The executed measurement mode, SWEEp or SAMPLing, is selected by the :PAGE:CHANnels[:CDEFinition]:MODE command.

This command changes the present display page to the GRAPH/LIST: LIST or GRAPH/LIST: GRAPHICS page, which is selected by the :PAGE:DISPlay[:SETup]:MODE command.

Executing this command is about the same as pressing Single front-panel key.

This command does not have query form.

Syntax :PAGE:SCONtrol [:MEASurement] :SINGle

Example OUTPUT @Hp4155; ":PAGE:SCON:SING"

See also :PAGE:CHANnels[:CDEFinition]:MODE and :PAGE:DISPlay[:SETup]:MODE

SCPI Commands
:PAGE:SCONtrol:STANdby

:PAGE:SCONtrol:STANdby

This command controls the output of standby channels.

This command can be executed only when the present state is IDLE or STANDBY. But the query can be executed for any state.

Executing this command is about the same as pressing Standby front-panel key.

At *RST, this value is OFF.

Syntax :PAGE:SCONtrol:STANdby OFF | ON | 0 | 1

Parameter

Parameter	Type	Explanation
OFF or 0	boolean	change to IDLE state
ON or 1	boolean	change to STANDBY state

Query response 0 | 1 <newline><<^END>

Example
OUTPUT @Hp4155;":PAGE:SCON:STAN ON"
OUTPUT @Hp4155;":PAGE:SCON:STAN?"
ENTER @Hp4155;A

:PAGE:SCONtrol:STATe?

This command returns the present state of the 4155C/4156C.

This command has query form *only*.

Syntax :PAGE:SCONtrol:STATe?

Query response IDLE | STAN | MEAS | STR <newline><<^END>

Parameter	Type	Explanation
IDLE	character	IDLE state
STAN	character	STANdby state
MEAS	character	MEASurement state
STR	character	STRess state

Example
OUTPUT @Hp4155;":PAGE:SCON:STAT?"
ENTER @Hp4155;A\$

:PAGE:SCONtrol:STOP

This command stops the currently executing operation (SWEEP, SAMPLING, STRESS, or KNOB SWEEP).

Executing this command is about the same as pressing Stop front-panel key.

This command does not have query form.

Syntax :PAGE:SCONtrol:STOP

Example OUTPUT @Hp4155;":PAGE:SCON:STOP"

:PAGE:SCONtrol:STRes[s]:STARt]

This command starts the STRes[s] force operation.

This command changes the present display page to the STRESS: STRESS FORCE page.

Executing this command is about the same as pressing Stress front-panel key.

This command does not have query form.

Syntax :PAGE:SCONtrol:STRes[s] [:STARt]

Example OUTPUT @Hp4155;":PAGE:SCON:STR"

:PAGE:SCONtrol:TRIGger:INPut?

This command waits for the external trigger input and returns 1 just after detecting trigger. This command has query form *only*.

Syntax Parameter :PAGE:SCONtrol:TRIGger:INPut? POSitive | NEGative | EITHer

Parameter	Type	Explanation
POSitive	character	positive slope is regarded as the trigger
NEGative	character	negative slope is regarded as the trigger
EITHer	character	positive or negative slope is regarded as the trigger

Query response 1 <newline><^END>

Example OUTPUT @Hp4155;":PAGE:SCON:TRIG:INP? POS"
ENTER @Hp4155;A

SCPI Commands

:PAGE:SCONtrol:TRIGger:OUTPut:LEVel

:PAGE:SCONtrol:TRIGger:OUTPut:LEVel

This command outputs a level trigger from the external trigger output terminal.

This command does not have query form.

Syntax Parameter

:PAGE:SCONtrol:TRIGger:OUTPut:LEVel HIGH | LOW

Parameter	Type	Explanation
HIGH	character	output level is changed to HIGH
LOW	character	output level is changed to LOW

Example

```
OUTPUT @Hp4155;":PAGE:SCON:TRIG:OUTP:LEV HIGH"
```

:PAGE:SCONtrol:TRIGger:OUTPut[:PULSe]

This command outputs a pulse trigger from the external trigger output terminal.

This command does not have query form.

Syntax Parameter

:PAGE:SCONtrol:TRIGger:OUTPut [:PULSe] POSitive | NEGative

Parameter	Type	Explanation
POSitive	character	output level is changed to LOW-HIGH-LOW
NEGative	character	output level is changed to HIGH-LOW-HIGH

Example

```
OUTPUT @Hp4155;":PAGE:SCON:TRIG:OUTP POS"
```

:PAGE:SCONtrol:ZERO

This command measures the zero offset that will be used for zero offset cancellation.

Executing this command is about the same as pressing Green front-panel key, then pressing Stop front-panel key.

This command does not have query form.

Syntax

:PAGE:SCONtrol:ZERO

Example

```
OUTPUT @Hp4155;":PAGE:SCON:ZERO"
```

:PAGE:STR Commands

:PAGE:STR commands set the STRESS pages.

Command	Parameter
:PAGE	
:STress	
[:CDEFinition]	
:ALL	
:DISable	
:COMment	<string>
:GNDU	
:DISable	
:FUNCTion?	
:MODE?	
:NAME	<name>
[:MENU]	
:PGU(1 2)	
:DISable	
:FUNCTion	SYNC NSYNc
:MODE	V VPULse
:NAME	<name>
:SELector(1 2 3 4)	
:MEASure	SMU PGU OPEN POPen
:STress	SMU PGU OPEN POPen
:SMU(1 2 3 4 5 6)	
:DISable	
:FUNCTion	SYNC NSYNc
:MODE	V I COMMOn
:NAME	<name>

SCPI Commands

Command	Parameter
:PAGE	
:STress	
[:CDEFinition]	
:TRIGger	
:POLarity	POSitive NEGative
[:STATe]	0 1 OFF ON
:VSU(1 2)	
:DISable	
:FUNCTion	SYNC NSYNc
:MODE?	
:NAME	<name>
:FORCe	
:ACCumulate	RESet
[:MENU]	
:STATus	RESet
:SETup	
:ACCumulate	RESet <numeric_value>
:CONStant	
:PGU(1 2)	
[:SOURce]	<numeric_value>
:SMU(1 2 3 4 5 6)	
:COMPLiance	<numeric_value>
[:SOURce]	<numeric_value>
:VSU(1 2)	
[:SOURce]	<numeric_value>
:DURation	<numeric_value>
:FILTer	0 1 OFF ON
:HTIME	<numeric_value>
[:MENU]	
:MODE	PCOunt DURation
:PCOunt	<numeric_value>

Command	Parameter
:PAGE	
:STress	
:SETup	
:PULSe	
:PGU(1 2)	
:BASE	<numeric_value>
:DELay	<numeric_value>
:IMPedance	LOW R50
:LEADing	<numeric_value>
:PEAK	<numeric_value>
:PERiod	<numeric_value>
:TRAILing	<numeric_value>
:WIDTh	<numeric_value>
:SSTop	ABNormal COMPLIance OFF

SCPI Commands
:PAGE:STress[:CDEFinition]:ALL:DISable

:PAGE:STress[:CDEFinition]:ALL:DISable

This command deletes the stress settings of all units (SMU,VSU,PGU,GNDU).

This command does not have query form.

Syntax :PAGE:STress [:CDEFinition] :ALL:DISable

Example OUTPUT @Hp4155;":PAGE:STR:ALL:DIS"

:PAGE:STress[:CDEFinition]:COMMent

This command sets the USER DEFINED COMMENT for the stress group.

At *RST, this value is not defined.

Syntax :PAGE:STress [:CDEFinition] :COMMent *comment*

Parameter

Parameter	Type	Explanation
<i>comment</i>	string	String of up to 58 characters.

Query response *comment* <newline><^END>

Example OUTPUT @Hp4155;":PAGE:STR:COMM 'PulseStress'"
OUTPUT @Hp4155;":PAGE:STR:COMM?"
ENTER @Hp4155;A\$

:PAGE:STress[:CDEFinition]:GNDU:DISable

This command disables the stress settings of GNDU.

This command does not have query form.

Syntax :PAGE:STress [:CDEFinition] :GNDU:DISable

Example OUTPUT @Hp4155;":PAGE:STR:GNDU:DIS"

:PAGE:STress[:CDEFinition]:GNDU:FUNCTION?

This command returns the function (FCTN) of GNDU for stress.

This command has query form *only*.

Syntax :PAGE:STress [:CDEFinition] :GNDU:FUNCTION?

Query response NSYN | DIS <newline><^END>

When the GNDU is not used, the response data may be DIS (DISable).

Example
OUTPUT @Hp4155;":PAGE:STR:GNDU:FUNC?"
ENTER @Hp4155;A\$

:PAGE:STress[:CDEFinition]:GNDU:MODE?

This command returns the output MODE of GNDU for stress.

This command has query form *only*.

Syntax :PAGE:STress [:CDEFinition] :GNDU:MODE?

Query response COMM | DIS <newline><^END>

When the GNDU is not used, the response data may be DIS (DISable).

Example
OUTPUT @Hp4155;":PAGE:STR:GNDU:MODE?"
ENTER @Hp4155;A\$

SCPI Commands
:PAGE:STress[:CDEFinition]:GNDU:NAME

:PAGE:STress[:CDEFinition]:GNDU:NAME

This command sets the NAME of GNDU for stress.

At *RST, this value is undefined.

Syntax :PAGE:STress [:CDEFinition] :GNDU:NAME *name*

Parameter

Parameter	Type	Explanation
<i>name</i>	string	String of up to 6 alphanumeric characters. 1st character must be alphabet.

Query response *name* <newline><^END>

name is string response data, but does not contain double quote characters at the beginning and end of the string.

Example
OUTPUT @Hp4155;":PAGE:STR:GNDU:NAME 'VD'"
OUTPUT @Hp4155;":PAGE:STR:GNDU:NAME?"
ENTER @Hp4155;A\$

:PAGE:STress[:CDEFinition][:MENU]

This command changes the present display page to STRESS: CHANNEL DEFINITION page.

This command does not have query form.

Syntax :PAGE:STress [:CDEFinition] [:MENU]

Example OUTPUT @Hp4155;":PAGE:STR"

:PAGE:STress[:CDEFinition]:PGU<n>:DISable

This command deletes the stress settings of PGU<n>.

<n> is required to specify PGU number. Valid PGU numbers are PGU1 through PGU2.

This command does not have query form.

Syntax :PAGE:STress [:CDEFinition] :PGU<n>:DISable

Example OUTPUT @Hp4155; ":PAGE:STR:PGU1:DIS"

:PAGE:STress[:CDEFinition]:PGU<n>:FUNCTION

This command sets the function (FCTN) of PGU<n> for stress.

<n> is required to specify PGU number. Valid PGU numbers are PGU1 through PGU2.

At *RST, this value is not defined.

Syntax :PAGE:STress [:CDEFinition] :PGU<n>:FUNCTION SYNC | NSYNc

Parameter

Parameter	Type	Explanation
SYNC	character	synchronous stress output
NSYNc	character	non-synchronous (non-stress output)

Query response SYNC | NSYN | DIS <newline><^END>

If PGU is not used, the response data may be DIS (DISable).

Example OUTPUT @Hp4155; ":PAGE:STR:PGU1:FUNC SYNC"

```
OUTPUT @Hp4155; ":PAGE:STR:PGU1:FUNC?"
ENTER @Hp4155;A$
```

SCPI Commands

:PAGE:STress[:CDEFinition]:PGU<n>:MODE

:PAGE:STress[:CDEFinition]:PGU<n>:MODE

This command sets the output MODE of PGU<n> for stress.

<n> is required to specify PGU number. Valid PGU numbers are PGU1 through PGU2.

At *RST, this value is not defined.

Syntax

:PAGE:STress [:CDEFinition] :PGU<n>:MODE V | VPULse

Parameter

Parameter	Type	Explanation
V	character	voltage output mode
VPULse	character	voltage pulse output mode

Query response

V | VPUL | DIS <newline><^END>

If PGU is not used, the response data may be DIS (DISable).

Example

```
OUTPUT @Hp4155;":PAGE:STR:PGU1:MODE V"  
OUTPUT @Hp4155;":PAGE:STR:PGU1:MODE?"  
ENTER @Hp4155;A$
```

:PAGE:STress[:CDEFinition]:PGU<n>:NAME

This command sets the NAME of PGU<n> for stress.

<n> is required to specify PGU number. Valid PGU numbers are PGU1 through PGU2.

At *RST, this value is not defined.

Syntax

:PAGE:STress [:CDEFinition] :PGU<n>:NAME *name*

Parameter

Parameter	Type	Explanation
<i>name</i>	string	String of up to 6 alphanumeric characters. 1st character must be alphabet.

Query response *name* <newline><^END>

name is string response data, but does not contain double quote characters at the beginning and end of the string.

Example OUTPUT @Hp4155;":PAGE:STR:PGU1:NAME 'VD' "
 OUTPUT @Hp4155;":PAGE:STR:PGU1:NAME?"
 ENTER @Hp4155;A\$

:PAGE:STress[:CDEFinition]:SELector<n>:MEASure

This command selects the relay connection mode of Agilent 16440A SMU/PGU selector *for measurement state*.

<n> is required to specify the SMU/PGU selector number. Valid SMU/PGU selector numbers are SELector1 through SELector4.

At *RST, this value is OPEN.

Syntax :PAGE:STress [:CDEFinition] :SELector<n>:MEASure SMU | PGU | OPEN | POPen

Parameter

Parameter	Type	Explanation
SMU	character	connect to SMU port
PGU	character	connect to PGU port
OPEN	character	disconnect all
POPen	character	disconnect all, but disconnect PGU port with semiconductor switch, not normal switch. This parameter is valid only for selector 1 and 3.

Query response SMU | PGU | OPEN | POP <newline><^END>

Example OUTPUT @Hp4155;":PAGE:STR:SEL1:MEAS SMU"
 OUTPUT @Hp4155;":PAGE:STR:SEL1:MEAS?"
 ENTER @Hp4155;A\$

SCPI Commands

:PAGE:STress[:CDEFinition]:SELector<n>:STress

:PAGE:STress[:CDEFinition]:SELector<n>:STress

This command selects the relay connection mode of Agilent 16440A SMU/PGU selector *n* for stress state.

<n> is required to specify the SMU/PGU selector number. Valid SMU/PGU selector numbers are SELector1 through SELector4.

At *RST, this value is OPEN.

Syntax

:PAGE:STress [:CDEFinition] :SELector<n>:STress SMU | PGU | OPEN | POPen

Parameter

Parameter	Type	Explanation
SMU	character	connect to SMU port
PGU	character	connect to PGU port
OPEN	character	disconnect all
POPen	character	disconnect all, but disconnect PGU port with semiconductor switch, not normal switch. This parameter is valid only for selector 1 and 3.

Query response

SMU | PGU | OPEN | POP <newline><^END>

Example

```
OUTPUT @Hp4155;":PAGE:STR:SEL1:STR SMU"  
OUTPUT @Hp4155;":PAGE:STR:SEL1:STR?"  
ENTER @Hp4155;A$
```

:PAGE:STress[:CDEFinition]:SMU<n>:DISable

This command deletes the stress settings of SMU<n>.

<n> is required to specify SMU number. Valid SMU numbers are SMU1 through SMU6, depending on the configuration.

This command does not have query form.

Syntax

:PAGE:STress [:CDEFinition] :SMU<n>:DISable

Example

```
OUTPUT @Hp4155;":PAGE:STR:SMU1:DIS"
```

:PAGE:STress[:CDEFinition]:SMU<n>:FUNCTION

This command sets the function (FCTN) of SMU<n> for stress.

<n> is required to specify SMU number. Valid SMU numbers are SMU1 through SMU6, depending on the configuration.

At *RST, this value is:

SMU	FUNCTION
SMU1	NSYNC
SMU2 to 4	SYNC
SMU5 and SMU6	not defined

Syntax

:PAGE:STress [:CDEFinition] :SMU<n>:FUNCTION SYNC | NSYNc

Parameter

Parameter	Type	Explanation
SYNC	character	synchronous stress output
NSYNc	character	non-synchronous (non-stress output)

Query response

SYNC | NSYN | DIS <newline><^END>

If SMU is not used, the response data may be DIS (DISable).

Example

```
OUTPUT @Hp4155;":PAGE:STR:SMU1:FUNC SYNC"
OUTPUT @Hp4155;":PAGE:STR:SMU1:FUNC?"
ENTER @Hp4155;A$
```

SCPI Commands

:PAGE:STRes[s[:CDEFinition]:SMU<n>:MODE

:PAGE:STRes[s[:CDEFinition]:SMU<n>:MODE

This command sets the output MODE of SMU<n> for stress.

<n> is required to specify SMU number. Valid SMU numbers are SMU1 through SMU6, depending on the configuration.

At *RST, this value is:

SMU	OUTPUT MODE
SMU1	COMMon
SMU2 to SMU4	V
SMU5 and SMU6	not defined.

Syntax

:PAGE:STRes [:CDEFinition] :SMU<n>:MODE V | I | COMMon

Parameter

Parameter	Type	Explanation
V	character	voltage output mode
I	character	current output mode
COMMon	character	common

Query response

V | I | COMM | DIS <newline><^END>

If SMU is not used, the response data may be DIS (DISable).

Example

```
OUTPUT @Hp4155;":PAGE:STR:SMU1:MODE V"  
OUTPUT @Hp4155;":PAGE:STR:SMU1:MODE?"  
ENTER @Hp4155;A$
```

:PAGE:STress[:CDEFinition]:SMU<n>:NAME

This command sets the NAME of SMU<n> for stress.

<n> is required to specify SMU number. Valid SMU numbers are SMU1 through SMU6, depending on the configuration.

At *RST, this value is:

SMU	NAME
SMU1 through SMU4	V<n>
SMU5 and SMU6	not defined

Syntax

:PAGE:STress [:CDEFinition] :SMU<n>:NAME *name*

Parameter

Parameter	Type	Explanation
<i>name</i>	string	String of up to 6 alphanumeric characters. 1st character must be alphabet.

Query response

name <newline><^END>

name is string response data, but does not contain double quote characters at the beginning and end of the string.

Example

```
OUTPUT @Hp4155;":PAGE:STR:SMU1:NAME 'VD'"
OUTPUT @Hp4155;":PAGE:STR:SMU1:NAME?"
ENTER @Hp4155;A$
```

SCPI Commands

:PAGE:STress[:CDEFinition]:TRIGger:POLarity

:PAGE:STress[:CDEFinition]:TRIGger:POLarity

This command sets the POLARITY of trigger signal for stress.

At *RST, this value is POSitive.

Syntax

:PAGE:STress [:CDEFinition] :TRIGger:POLarity POSitive | NEGative

Parameter

Parameter	Type	Explanation
POSitive	character	polarity is positive
NEGative	character	polarity is negative

Query response

POS | NEG <newline><^END>

Example

```
OUTPUT @Hp4155;":PAGE:STR:TRIG:POL POS"  
OUTPUT @Hp4155;":PAGE:STR:TRIG:POL?"  
ENTER @Hp4155;A$
```

:PAGE:STress[:CDEFinition]:TRIGger[:STATe]

This command controls whether the trigger function is enabled for stress.

At *RST, this value is DISable.

Syntax

:PAGE:STress [:CDEFinition] :TRIGger [:STATe] OFF | ON | 0 | 1

Parameter

Parameter	Type	Explanation
OFF or 0	boolean	trigger function is disabled
ON or 1	boolean	trigger function is enabled

Query response

0 | 1 <newline><^END>

Example

```
OUTPUT @Hp4155;":PAGE:STR:TRIG ON"  
OUTPUT @Hp4155;":PAGE:STR:TRIG?"  
ENTER @Hp4155;A
```

:PAGE:STress[:CDEFinition]:VSU<n>:DISable

This command deletes the stress settings of VSU<n>.

<n> is required to specify VSU number. Valid VSU numbers are VSU1 through VSU2.

This command does not have query form.

Syntax :PAGE:STress [:CDEFinition] :VSU<n>:DISable

Example OUTPUT @Hp4155;":PAGE:STR:VSU1:DIS"

:PAGE:STress[:CDEFinition]:VSU<n>:FUNCTION

This command sets the function (FCTN) of VSU<n> for stress.

<n> is required to specify VSU number. Valid VSU numbers are VSU1 through VSU2.

At *RST, this value is NSYNC.

Syntax :PAGE:STress [:CDEFinition] :VSU<n>:FUNCTION SYNC | NSYNc

Parameter

Parameter	Type	Explanation
SYNC	character	synchronous stress output
NSYNc	character	non-synchronous (non-stress output)

Query response SYNC | NSYN | DIS <newline><^END>

If VSU is not used, the response data may be DIS (DISable).

Example OUTPUT @Hp4155;":PAGE:STR:VSU1:FUNC SYNC"

```
OUTPUT @Hp4155;":PAGE:STR:VSU1:FUNC?"
ENTER @Hp4155;A$
```

SCPI Commands

:PAGE:STress[:CDEFinition]:VSU<n>:MODE?

:PAGE:STress[:CDEFinition]:VSU<n>:MODE?

This command returns the output MODE of VSU<n> for stress.

<n> is required to specify VSU number. Valid VSU numbers are VSU1 through VSU2.

This command has query form *only*. At *RST, this value is V.

Syntax

:PAGE:STress [:CDEFinition] :VSU<n>:MODE?

Query response

V | DIS <newline><^END>

When the specified VSU is not used, the response data may be DIS (DISable).

Example

```
OUTPUT @Hp4155;":PAGE:STR:VSU1:MODE?"
ENTER @Hp4155;A$
```

:PAGE:STress[:CDEFinition]:VSU<n>:NAME

This command sets the NAME of VSU<n> for stress.

<n> is required to specify VSU number. Valid VSU numbers are VSU1 through VSU2.

At *RST, this value is VSU<n>.

Syntax

:PAGE:STress [:CDEFinition] :VSU<n>:NAME *name*

Parameter

Parameter	Type	Explanation
<i>name</i>	string	String of up to 6 alphanumeric characters. 1st character must be alphabet.

Query response

name <newline><^END>

name is string response data, but does not contain double quote characters at the beginning and end of the string.

Example

```
OUTPUT @Hp4155;":PAGE:STR:VSU1:NAME 'VD'"
OUTPUT @Hp4155;":PAGE:STR:VSU1:NAME?"
ENTER @Hp4155;A$
```

:PAGE:STress:FORCe:ACCumulate

This command resets the accumulated stress time to 0.

Query returns the accumulated stress time.

At *RST, the accumulated stress time is 0.

Syntax

:PAGE:STress:FORCe:ACCumulate RESet

Parameter

Parameter	Type	Explanation
RESet	character	reset accumulated time to zero

Query response

accumulate <newline><^END>

accumulate is NR3 response data type.

Example

```
OUTPUT @Hp4155;":PAGE:STR:FORC:ACC RES"
```

```
OUTPUT @Hp4155;":PAGE:STR:FORC:ACC?"
```

```
ENTER @Hp4155;A
```

:PAGE:STress:FORCe[:MENU]

This command changes the present display page to STRESS: STRESS FORCE.

This command does not have query form.

Syntax

:PAGE:STress:FORCe [:MENU]

Example

```
OUTPUT @Hp4155;":PAGE:STR:FORC"
```

SCPI Commands
:PAGE:STRes:FORCe:STATus

:PAGE:STRes:FORCe:STATus

This command resets the stress status (time and percent) to zero.

Query returns the stress time forced and percent completion of the stress duration setting.

At *RST, stress time and percent are 0.

Syntax :PAGE:STRes:FORCe:STATus RESet

Parameter

Parameter	Type	Explanation
RESet	character	reset the status to zero

Query response *time, rate* <newline><^END>

time and *rate* are NR3 response data type.

Example

```
OUTPUT @Hp4155;":PAGE:STR:FORC:STAT RES"  
OUTPUT @Hp4155;":PAGE:STR:FORC:STAT?"  
ENTER @Hp4155;A,B
```

:PAGE:STRes:SETup:ACCumulate

This command sets the amount of stress that has already been forced to the device.

At *RST, this value is 0.

Syntax :PAGE:STRes:SETup:ACCumulate RESet | *accumulate*

Parameter

Parameter	Type	Explanation
RESet	character	reset accumulated time to zero
<i>accumulate</i>	numeric	0 and above

Query response *accumulate* <newline><^END>

accumulate is NR3 response data type.

:PAGE:STress:SETup:CONStant:PGU<n>[:SOURce]

Example

```
OUTPUT @Hp4155;":PAGE:STR:SET:ACC RES"
OUTPUT @Hp4155;":PAGE:STR:SET:ACC?"
ENTER @Hp4155;A
```

:PAGE:STress:SETup:CONStant:PGU<n>[:SOURce]

This command sets the constant SOURCE value of PGU<n> for stress.

<n> is required to specify PGU number. Valid PGU numbers are PGU1 through PGU2.

You use this command only if the specified PGU is set to V mode (not VPULSE) by the :PAGE:STR:PGU<n>:MODE command.

At *RST, this value is 0.

Syntax

```
:PAGE:STress:SETup:CONStant:PGU<n> [ :SOURce] source | MINimum |
MAXimum
```

Parameter

Parameter	Type	Explanation
<i>source</i>	numeric	-40 to 40 V

Query response

```
source <newline><^END>
```

source is NR3 response data type.

Example

```
OUTPUT @Hp4155;":PAGE:STR:SET:CONS:PGU1 10"
OUTPUT @Hp4155;":PAGE:STR:SET:CONS:PGU1 MAX"
OUTPUT @Hp4155;":PAGE:STR:SET:CONS:PGU1?"
ENTER @Hp4155;A

OUTPUT @Hp4155;":PAGE:STR:SET:CONS:PGU1? MAX"
ENTER @Hp4155;A
```

SCPI Commands

:PAGE:STress:SETup:CONStant:SMU<n>:COMpliance

:PAGE:STress:SETup:CONStant:SMU<n>:COMpliance

This command sets the constant COMPLIANCE value of SMU<n> for stress.

<n> is required to specify SMU number. Valid SMU numbers are SMU1 through SMU6, depending on the configuration.

The mode of the specified SMU must be V or I.

At *RST, this value is:

SMU	COMPLIANCE
SMU1	not defined
SMU2 to SMU4	100 mA
SMU5 and SMU6	not defined

Syntax

:PAGE:STress:SETup:CONStant:SMU<n>:COMpliance *compliance* | MINmum | MAXimum

Parameter

Parameter	Type	Explanation
<i>compliance</i>	numeric	-200 to 200 V or -1 to 1 A. The range of this value depends on the type of SMU.

Query response

compliance <newline><^END>

compliance is NR3 response data type.

Example

```
OUTPUT @Hp4155;":PAGE:STR:SET:CONS:SMU1:COMP 0.1"
OUTPUT @Hp4155;":PAGE:STR:SET:CONS:SMU1:COMP MAX"
OUTPUT @Hp4155;":PAGE:STR:SET:CONS:SMU1:COMP?"
ENTER @Hp4155;A
OUTPUT @Hp4155;":PAGE:STR:SET:CONS:SMU1:COMP? MAX"
ENTER @Hp4155;A
```

:PAGE:STress:SETup:CONStant:SMU<n>[:SOURce]

:PAGE:STress:SETup:CONStant:SMU<n>[:SOURce]

This command sets the constant SOURCE value of SMU<n> for stress.

<n> is required to specify SMU number. Valid SMU numbers are SMU1 through SMU6, depending on the configuration.

The mode of the specified SMU must be V or I.

At *RST, this value is:

SMU	SOURCE
SMU1	not defined
SMU2 to SMU4	0 V

Syntax

:PAGE:STress:SETup:CONStant:SMU<n> [:SOURce] *source* | MINimum | MAXimum

Parameter

Parameter	Type	Explanation
<i>source</i>	numeric	-200 to 200 V or -1 to 1 A. The range of this value depends on the type of SMU.

Query response

source <newline><^END>

source is NR3 response data type.

Example

```
OUTPUT @Hp4155;":PAGE:STR:SET:CONS:SMU1 10"
OUTPUT @Hp4155;":PAGE:STR:SET:CONS:SMU1 MAX"
OUTPUT @Hp4155;":PAGE:STR:SET:CONS:SMU1?"
ENTER @Hp4155;A
OUTPUT @Hp4155;":PAGE:STR:SET:CONS:SMU1? MAX"
ENTER @Hp4155;A
```

SCPI Commands

:PAGE:STress:SETup:CONStant:VSU<n>[:SOURce]

:PAGE:STress:SETup:CONStant:VSU<n>[:SOURce]

This command sets the constant SOURCE value of VSU<n> for stress.

<n> is required to specify VSU number. Valid VSU numbers are VSU1 through VSU2.

The specified VSU must not be DISable.

At *RST, this value is 0.

Syntax

:PAGE:STress:SETup:CONStant:VSU<n> [:SOURce] *source* | MINimum | MAXimum

Parameter

Parameter	Type	Explanation
<i>source</i>	numeric	-20 to 20 V

Query response

source <newline><^END>

source is NR3 response data type.

Example

```
OUTPUT @Hp4155;":PAGE:STR:SET:CONS:VSU1 10"  
OUTPUT @Hp4155;":PAGE:STR:SET:CONS:VSU1 MAX"  
OUTPUT @Hp4155;":PAGE:STR:SET:CONS:VSU1?"  
ENTER @Hp4155;A  
OUTPUT @Hp4155;":PAGE:STR:SET:CONS:VSU1? MAX"  
ENTER @Hp4155;A
```

:PAGE:STress:SETup:DURation

This command sets the stress time in seconds.

If :SETup:MODE is PCOUNT, this parameter is not used.

At *RST, this value is 1 ms.

Syntax

:PAGE:STress:SETup:DURation *duration* | MINimum | MAXimum

Parameter

Parameter	Type	Explanation
<i>duration</i>	numeric	0 to 31536000 s (31536000 s is 1 year). 0 means free run.

Query response

duration <newline><^END>

duration is NR3 response data type.

Example

```
OUTPUT @Hp4155;":PAGE:STR:SET:DUR 10"
OUTPUT @Hp4155;":PAGE:STR:SET:DUR MAX"
OUTPUT @Hp4155;":PAGE:STR:SET:DUR?"
ENTER @Hp4155;A
OUTPUT @Hp4155;":PAGE:STR:SET:DUR? MAX"
ENTER @Hp4155;A
```

:PAGE:STResS:SETup:FILTER

This command sets the SMU output filter state for stress.

At *RST, this value is OFF.

Syntax

:PAGE:STResS:SETup:FILTER OFF | ON | 0 | 1

Parameter

Parameter	Type	Explanation
OFF <i>or</i> 0	boolean	filter is turned off.
ON <i>or</i> 1	boolean	filter is turned on.

Query response

0 | 1 <newline><^END>

Example

```
OUTPUT @Hp4155;":PAGE:STR:SET:FILT ON"
OUTPUT @Hp4155;":PAGE:STR:SET:FILT?"
ENTER @Hp4155;A
```

SCPI Commands
:PAGE:STress:SETup:HTIME

:PAGE:STress:SETup:HTIME

This command sets the hold time to wait between the non-synchronous (non-stress) channel output and the synchronous channel (stress) output.

At *RST, this value is 0.

Syntax :PAGE:STress:SETup:HTIME *hold_time* | MINimum | MAXimum

Parameter

Parameter	Type	Explanation
<i>hold_time</i>	numeric	0 to 655.35 (s)

Query response *hold_time* <newline><^END>

hold_time is NR3 response data type.

Example

```
OUTPUT @Hp4155;":PAGE:STR:SET:HTIM 0.5"  
OUTPUT @Hp4155;":PAGE:STR:SET:HTIM MAX"  
OUTPUT @Hp4155;":PAGE:STR:SET:HTIM?"  
ENTER @Hp4155;A  
OUTPUT @Hp4155;":PAGE:STR:SET:HTIM? MAX"  
ENTER Hp4155;A
```

:PAGE:STress:SETup[:MENU]

This command changes the present display page to STRESS: STRESS SETUP.

This command does not have query form.

Syntax :PAGE:STress:SETup [:MENU]

Example OUTPUT @Hp4155;":PAGE:STR:SET"

:PAGE:STress:SETup:MODE

This command selects the stress mode.

If no PGU is set to VPULse mode, stress mode must be set to DURation.

At *RST, this value is DURation.

Syntax :PAGE:STress:SETup:MODE DURation | PCOut

Parameter

Parameter	Type	Explanation
DURation	character	specify the stress time by duration
PCOut	character	specify the stress time by pulse count

Query response

DURation | PCOut <newline><^END>

Example

```
OUTPUT @Hp4155;":PAGE:STR:SET:MODE DUR"
OUTPUT @Hp4155;":PAGE:STR:SET:MODE?"
ENTER @Hp4155;A$
```

:PAGE:STResS:SETup:PCOut

This command sets the stress time by the number of output pulses.

If :SETup:MODE is DURation, this parameter is not used.

Syntax

:PAGE:STResS:SETup:PCOut *pcount* | MINimum | MAXimum

Parameter

Parameter	Type	Explanation
<i>pcount</i>	numeric	0 to 65535. 0 means free run.

Query response

pcount <newline><^END>

pcount is NR1 response data type.

Example

```
OUTPUT @Hp4155;":PAGE:STR:SET:PCO 10"
OUTPUT @Hp4155;":PAGE:STR:SET:PCO MAX"
OUTPUT @Hp4155;":PAGE:STR:SET:PCO?"
ENTER @Hp4155;A
OUTPUT @Hp4155;":PAGE:STR:SET:PCO? MAX"
ENTER @Hp4155;A
```

SCPI Commands

:PAGE:STRes:SETup:PULSe:PGU<n>:BASE

:PAGE:STRes:SETup:PULSe:PGU<n>:BASE

This command sets the BASE VALUE of PGU<n> for stress.

<n> is required to specify PGU number. Valid PGU numbers are PGU1 through PGU2.

The mode of the specified PGU must be VPULSe.

At *RST, this value is 0.

Syntax

:PAGE:STRes:SETup:PULSe:PGU<n>:BASE *base* | MINimum | MAXimum

Parameter

Parameter	Type	Explanation
<i>base</i>	numeric	-40 to 40 V

Query response

base <newline><^END>

base is NR3 response data type.

Example

```
OUTPUT @Hp4155;":PAGE:STR:SET:PULS:PGU1:BASE 1"  
OUTPUT @Hp4155;":PAGE:STR:SET:PULS:PGU1:BASE?"  
ENTER @Hp4155;A
```

:PAGE:STRes:SETup:PULSe:PGU<n>:DElay

This command sets the DELAY TIME of PGU<n> for stress.

<n> is required to specify PGU number. Valid PGU numbers are PGU1 through PGU2.

The mode of the specified PGU must be VPULSe.

At *RST, this value is 0.

Syntax

:PAGE:STRes:SETup:PULSe:PGU<n>:DElay *delay_time* | MINimum | MAXimum

Parameter

Parameter	Type	Explanation
<i>delay_time</i>	numeric	0 to 10 (s)

Query response *delay_time* <newline><^END>

delay_time is NR3 response data type.

Example

```
OUTPUT @Hp4155;":PAGE:STR:SET:PULS:PGU1:DEL 1"
OUTPUT @Hp4155;":PAGE:STR:SET:PULS:PGU1:DEL MAX"
OUTPUT @Hp4155;":PAGE:STR:SET:PULS:PGU1:DEL?"
ENTER @Hp4155;A
OUTPUT @Hp4155;":PAGE:STR:SET:PULS:PGU1:DEL? MAX"
ENTER @Hp4155;A
```

:PAGE:STress:SETup:PULSe:PGU<n>:IMPedance

This command sets the output IMPEDANCE of PGU<n> for stress.

<n> is required to specify PGU number. Valid PGU numbers are PGU1 through PGU2.

The mode of the specified PGU must be VPULse.

At *RST, this value is LOW.

Syntax

:PAGE:STress:SETup:PULSe:PGU<n>:IMPedance LOW | R50

Parameter

Parameter	Type	Explanation
LOW	character	low impedance
R50	character	50 Ω

Query response LOW | R50 <newline><^END>

Example

```
OUTPUT @Hp4155;":PAGE:STR:SET:PULS:PGU1:IMP LOW"
OUTPUT @Hp4155;":PAGE:STR:SET:PULS:PGU1:IMP?"
ENTER @Hp4155;A$
```

SCPI Commands

:PAGE:STResS:SETup:PULSe:PGU<n>:LEADing

:PAGE:STResS:SETup:PULSe:PGU<n>:LEADing

This command sets the leading-edge transition time (LEADING TIME) of PGU<n> for stress.

<n> is required to specify PGU number. Valid PGU numbers are PGU1 through PGU2.

The mode of the specified PGU must be VPULSe.

At *RST, this value is 100 ns.

Syntax

:PAGE:STResS:SETup:PULSe:PGU<n>:LEADing *leading_time* | MINimum | MAXimum

Parameter

Parameter	Type	Explanation
<i>leading_time</i>	numeric	100E-9 to 10E-3 (s)

Query response

leading_time <newline><^END>

leading_time is NR3 response data type.

Example

```
OUTPUT @Hp4155;":PAGE:STR:SET:PULS:PGU1:LEAD 0.001"  
OUTPUT @Hp4155;":PAGE:STR:SET:PULS:PGU1:LEAD MAX"  
OUTPUT @Hp4155;":PAGE:STR:SET:PULS:PGU1:LEAD?"  
ENTER @Hp4155;A  
OUTPUT @Hp4155;":PAGE:STR:SET:PULS:PGU1:LEAD? MAX"  
ENTER @Hp4155;A
```

:PAGE:STress:SETup:PULSe:PGU<n>:PEAK

This command sets the PEAK VALUE of PGU<n> for stress.

<n> is required to specify PGU number. Valid PGU numbers are PGU1 through PGU2.

The mode of the specified PGU must be VPULSe.

At *RST, this value is 0.1 V.

Syntax :PAGE:STress:SETup:PULSe:PGU<n>:PEAK *peak* | MINimum | MAXimum

Parameter

Parameter	Type	Explanation
<i>peak</i>	numeric	-40 to 40 V

Query response *peak* <newline><^END>

peak is NR3 response data type.

Example

```
OUTPUT @Hp4155;":PAGE:STR:SET:PULS:PGU1:PEAK 5"
OUTPUT @Hp4155;":PAGE:STR:SET:PULS:PGU1:PEAK MAX"
OUTPUT @Hp4155;":PAGE:STR:SET:PULS:PGU1:PEAK?"
ENTER @Hp4155;A
OUTPUT @Hp4155;":PAGE:STR:SET:PULS:PGU1:PEAK? MAX"
ENTER @Hp4155;A
```

SCPI Commands

:PAGE:STRes:SETup:PULSe:PGU<n>:PERiod

:PAGE:STRes:SETup:PULSe:PGU<n>:PERiod

This command sets the pulse PERIOD of PGU<n> for stress.

<n> is required to specify PGU number. Valid PGU numbers are PGU1 through PGU2.

PGU1:PERiod and PGU2:PERiod are always set to the same value.

The mode of the specified PGU must be VPULse.

At *RST, this value is 10 ms.

Syntax

:PAGE:STRes:SETup:PULSe:PGU<n>:PERiod *period* | MINimum | MAXimum

Parameter

Parameter	Type	Explanation
<i>period</i>	numeric	2E-6 to 10 (s)

Query response

period <newline><^END>

period is NR3 response data type.

Example

```
OUTPUT @Hp4155;":PAGE:STR:SET:PULS:PGU1:PER 0.01"
```

```
OUTPUT @Hp4155;":PAGE:STR:SET:PULS:PGU1:PER MAX"
```

```
OUTPUT @Hp4155;":PAGE:STR:SET:PULS:PGU1:PER?"
```

```
ENTER @Hp4155;A
```

```
OUTPUT @Hp4155;":PAGE:STR:SET:PULS:PGU1:PER? MAX"
```

```
ENTER @Hp4155;A
```

:PAGE:STRes:SETup:PULSe:PGU<n>:TRAILing

This command sets the trailing-edge transition time (TRAILING TIME) of PGU<n> for stress.

<n> is required to specify PGU number. Valid PGU numbers are PGU1 through PGU2.

The mode of the specified PGU must be VPULse.

At *RST, this value is 100 ns.

Syntax

:PAGE:STRes:SETup:PULSe:PGU<n>:TRAILing *trailing_time* | MINimum | MAXimum

Parameter

Parameter	Type	Explanation
<i>trailing_time</i>	numeric	100 ns to 10 ms

Query response

trailing_time <newline><^END>

trailing_time is NR3 response data type.

Example

```
OUTPUT @Hp4155;":PAGE:STR:SET:PULS:PGU1:TRA 0.001"
OUTPUT @Hp4155;":PAGE:STR:SET:PULS:PGU1:TRA MAX"
OUTPUT @Hp4155;":PAGE:STR:SET:PULS:PGU1:TRA?"
ENTER @Hp4155;A
OUTPUT @Hp4155;":PAGE:STR:SET:PULS:PGU1:TRA? MAX"
ENTER @Hp4155;A
```

:PAGE:STResS:SETup:PULSe:PGU<n>:WIDTh

This command sets the pulse WIDTH of PGU<n> for stress.

<n> is required to specify PGU number. Valid PGU numbers are PGU1 through PGU2.

The mode of the specified PGU must be VPULse.

At *RST, this value is 5 ms.

Syntax

:PAGE:STResS:SETup:PULSe:PGU<n>:WIDTh *width* | MINimum | MAXimum

Parameter

Parameter	Type	Explanation
<i>width</i>	numeric	1E-6 to 9.99 s

Query response

width <newline><^END>

width is NR3 response data type.

Example

```
OUTPUT @Hp4155;":PAGE:STR:SET:PULS:PGU1:WIDTH 0.005"
OUTPUT @Hp4155;":PAGE:STR:SET:PULS:PGU1:WIDTH MIN"
OUTPUT @Hp4155;":PAGE:STR:SET:PULS:PGU1:WIDTH?"
ENTER @Hp4155;A
```

SCPI Commands
:PAGE:STRes:SETup:SSTop

```
OUTPUT @Hp4155;":PAGE:STR:SET:PULS:PGU1:WIDTH? MIN"  
ENTER @Hp4155;A
```

:PAGE:STRes:SETup:SSTop

This command sets the stress stop mode for an abnormal status.

The abnormal statuses that can be detected are as follows:

- SMU reaches its compliance setting.
- Current of VSU exceeds ± 100 mA.
- SMU or VSU oscillates.
- A/D converter overflow occurs.
- Average current of PGU exceeds ± 100 mA.

At *RST, this value is OFF.

Syntax

:PAGE:STRes:SETup:SSTop ABNormal | COMPLIance | OFF

Parameter

Parameter	Type	Explanation
ABNormal	character	Stop stress if abnormal status is detected.
COMPLIance	character	Stops stress only if some SMU reaches its compliance setting.
OFF	character	Continue stress even if abnormal status is detected.

Query response

ABN | COMP | OFF <newline><^END>

Example

```
OUTPUT @Hp4155;":PAGE:STR:SET:SST ABN"  
OUTPUT @Hp4155;":PAGE:STR:SET:SST?"  
ENTER @Hp4155;A$
```

:PAGE:SYST Commands

:PAGE:SYST commands set the SYSTEM pages.

Command	Parameter
:PAGE	
:SYSTem	
:CDIagnostic	
[:MENU]	
:COLor	
[:MENU]	
:CONFig	
[:MENU]	
:FILer	
[:MENU]	
:MISC	
[:MENU]	
:PRINt	
[:MENU]	

SCPI Commands

:PAGE:SYSTem:CDIagnostic[:MENU]

:PAGE:SYSTem:CDIagnostic[:MENU]

This command changes the current display page to :SYSTEM: SELF-CALIBRATION/DIAGNOSTICS page.

This command does not have query form.

Syntax :PAGE:SYSTem:CDIagnostic [:MENU]

Example OUTPUT @Hp4155; ":PAGE:SYST:CDI"

:PAGE:SYSTem:COLor[:MENU]

This command changes the current display page to ":SYSTEM: COLOR SETUP" page.

This command does not have query form.

Syntax :PAGE:SYSTem:COLor [:MENU]

Example OUTPUT @Hp4155; ":PAGE:SYST:COL"

:PAGE:SYSTem:CONFig[:MENU]

This command changes the current display page to ":SYSTEM: CONFIGURATION" page.

This command does not have query form.

Syntax :PAGE:SYSTem:CONFig [:MENU]

Example OUTPUT @Hp4155; ":PAGE:SYST:CONF"

:PAGE:SYSTem:FILer[:MENU]

This command changes the current display page to ":SYSTEM: FILER" page.

This command does not have query form.

Syntax :PAGE:SYSTem:FILer [:MENU]

Example OUTPUT @Hp4155; ":PAGE:SYST:FIL"

:PAGE:SYSTem:MISC[:MENU]

This command changes the current display page to ":SYSTEM: MISCELLANEOUS" page.

This command does not have query form.

Syntax :PAGE:SYSTem:MISC [:MENU]

Example OUTPUT @Hp4155; ":PAGE:SYST:MISC"

:PAGE:SYSTem:PRINt[:MENU]

This command changes the current display page to ":SYSTEM: PRINT SETUP" page.

This command does not have query form.

Syntax :PAGE:SYSTem:PRINt [:MENU]

Example OUTPUT @Hp4155; ":PAGE:SYST:PRIN"

PROGram Subsystem

The PROGram subsystem downloads and controls the user-defined Instrument BASIC program in an instrument.

The following table is the command tree of PROGram subsystem.

Command	Parameter
:PROGram	
:CATalog?	
[:SElected]	
:DEFine	<program>
:DELete	
[:SElected]	
:ALL	
:EXECute	
:MALlocate	<nbytes> DEFault
:NAME	<prog_name>
:NUMBer	<varname> {,<nvalues>}
:STATE	RUN PAUSE STOP CONTinue
:STRing	<varname> {,<svalues>}
:WAIT	

To comply with SCPI, the following :EXPLicit subsystem is also implemented for the 4155C/4156C.

The function of :EXPLicit subsystem commands is same as corresponding above commands of :SELEcted subsystem.

The following table is the command tree of PROGram subsystem.

Command	Parameter
:PROGram	
:EXPLicit	
:DEFine	"PROG", <program>
:DELeTe	"PROG"
:EXECute	"PROG"
:MALLocate	"PROG", <nbytes> DEFault
:NUMBer	"PROG", <varname> {,<nvalues>}
:STATe	"PROG", RUN PAUSE STOP CONTinue
:STRing	"PROG", <varname> {,<svalues>}
:WAIT	"PROG"

SCPI Commands
:PROG:CATalog?

:PROG:CATalog?

For the 4155C/4156C, only one program can be downloaded. So, the response of this command is always "PROG".

Syntax :PROG:CATalog?

Query response "PROG" <newline><^END>

Example
OUTPUT @Hp4155;":PROG:CAT?"
ENTER @Hp4155;A\$

:PROG[:SElected]:DEFine

This command is used to create and download a program.

The query form of this command is used to upload a program.

Syntax :PROG [:SElected] :DEFine *program*

Parameter

Parameter	Type	Explanation
<i>program</i>	arbitrary block	block data of a program

Query response *program* <newline><^END>

program is uploaded as definite length arbitrary block response data.

Example
!Indefinite length example
OUTPUT @Hp4155;":PROG:DEF #0"
OUTPUT @Hp4155;"10 PRINT ""HELLO!""
OUTPUT @Hp4155;"20 END"
OUTPUT @Hp4155;" " END !Terminator

!Query example
DIM A\$[100000]
OUTPUT @Hp4155;":PROG:DEF?"
ENTER @Hp4155 USING "%,2A";HEAD\$
B=VAL(HEAD\$[2])
FOR I=1 TO B
ENTER @Hp4155 USING "%,A";HEAD\$
NEXT I
ENTER 717 USING "-K";A\$

:PROGram[:SELEcted]:DELEte[:SELEcted]

This command deletes the downloaded program.

This command does not have query form.

Syntax :PROGram [: SELEcted] :DELEte [: SELEcted]

Example OUTPUT @Hp4155; ": PROG:DEL"

:PROGram[:SELEcted]:DELEte:ALL

This command deletes the downloaded program.

For the 4155C/4156C, only one program can be downloaded. Therefore, this command is the same as :PROGram[:SELEcted]:DELEte[:SELEcted].

This command does not have query form.

Syntax :PROGram [: SELEcted] :DELEte:ALL

Example OUTPUT @Hp4155; ": PROG:DEL:ALL"

See also :PROGram[:SELEcted]:DELEte[:SELEcted]

:PROGram[:SELEcted]:EXECute

This command executes the specified Instrument BASIC command for the downloaded program.

The downloaded program must be in either the PAUSed or STOPped state.

This command does not have query form.

Syntax :PROGram [:SELEcted] :EXECute *command*

Parameter

Parameter	Type	Explanation
<i>command</i>	string	Instrument BASIC command

Example OUTPUT @Hp4155; ": PROG:EXEC 'STEP'"

SCPI Commands
:PROGram[:SElected]:MALLocate

:PROGram[:SElected]:MALLocate

This command is not implemented for the 4155C/4156C. This command is ignored, but does not cause an error.

:PROGram[:SElected]:NAME

This command is not implemented for the 4155C/4156C. This command is ignored, but does not cause an error.

The query form always returns "PROG" string.

:PROG[:SElected]:NUMBER

This command is used to set or query the contents of numeric variables and arrays in the downloaded program.

The specified variable must be the name of a variable in the downloaded program.

Syntax

:PROG [:SElected] :NUMBER *varname* { , *value* }

Parameter

Parameter	Type	Explanation
<i>varname</i>	string or character	name of the numeric variable or array
<i>value</i>	numeric	value to set for specified variable

When *varname* is numeric array, *values* are set from the first element of the array. If the number of *value* is less than number of array elements, the leftover elements are not changed. If the number of *value* is greater than number of array elements, extra *values* are ignored.

Query response

value { , *value* } <newline><^END>

value is NR3 response data type.

Example

```
OUTPUT @Hp4155;":PROG:NUMB A,5"
OUTPUT @Hp4155;":PROG:NUMB 'Ab',5,5,5,5,5"
OUTPUT @Hp4155;":PROG:NUMB? A"
ENTER @Hp4155;B

OUTPUT @Hp4155;":PROG:NUMB? 'Ab'"
ENTER @Hp4155;Ab(*)
```

:PROG[:SElected]:STATe

This command is used to set the state or query the state of the downloaded program.

The following table shows the result of setting the STATE for each of the possible current states.

desired state	current state		
	RUNNING	PAUSED	STOPPED
RUN	error (-221)	RUNNING	RUNNING
CONT	error (-221)	RUNNING	error (-221)
PAUSE	PAUSED	PAUSED	STOPPED
STOP	STOPPED	STOPPED	STOPPED

Syntax

:PROG [:SElected] :STATe RUN | PAUSE | STOP | CONTINUE

Query response

RUN | PAUS | STOP <newline><^END>

Example

```
OUTPUT @Hp4155;":PROG:STAT RUN"
OUTPUT @Hp4155;":PROG:STAT?"
ENTER @Hp4155;A$
```

SCPI Commands
:PROG[:SElected]:STRing

:PROG[:SElected]:STRing

This command is used to set or query the contents of string variables and arrays in the downloaded program.

The specified variable must be an existing variable in the downloaded program.

Syntax :PROG [:SElected] :STRing *varname* { , *string* }

Parameter

Parameter	Type	Explanation
<i>varname</i>	string or character	name of the string variable or array
<i>string</i>	string	string to set for specified variable

When *varname* is string array, *strings* are set from the first element of the array. If the number of *string* is less than number of array elements, the leftover elements are not changed. If the number of *string* is greater than number of array elements, extra *strings* are ignored.

Query response *string* { , *string* } <newline><^END>
string is string response data type.

Example
OUTPUT @Hp4155;":PROG:STR Ab, 'Voltage'"
OUTPUT @Hp4155;":PROG:STR 'Ab', 'Voltage', 'Current'"
OUTPUT @Hp4155;":PROG:STR? A"
ENTER @Hp4155;B\$

:PROG[:SElected]:WAIT

This command stops the execution of commands or queries until the downloaded program exits from the RUN state (that is, until program is STOPped or PAUSed).

Syntax :PROG [:SElected] :WAIT

Query response 1 <newline><^END>
A 1 is returned if the program is either STOPped or PAUSed.

Example
OUTPUT @Hp4155;":PROG:WAIT"
OUTPUT @Hp4155;":PROG:WAIT?"
ENTER @Hp4155;A

STATus Subsystem

The STATus subsystem accesses the non-IEEE488.2 status structures of the 4155C/4156C.

These status structures are as follows:

- Operation Status Register (for SCPI) Consists of CONDITION, TRANSITION FILTER, EVENT, and event enable (MASK) registers.
- Questionable Status Register (for SCPI) Consists of CONDITION, TRANSITION FILTER, EVENT, and event enable (MASK) registers.
- Emergency Status Register (for 4155C/4156C) Consists of EVENT and event enable (MASK) registers.
- Measure/Stress Status Register (for 4155C/4156C) Consists of EVENT and event enable (MASK) registers.

Refer to Chapter 3 for details about these registers and about the status-reporting structure of both non-IEEE488.2 and IEEE488.2 status structures.

The following table is the command tree of STATus subsystem.

Command	Parameter
:STATus	
:EMERgency	
:ENABle	<numeric_value>
[:EVENT] ?	
:MEASurement	
:ENABle	<numeric_value>
[:EVENT] ?	
:OPERation	
:CONDition?	
:ENABle	<numeric_value>
[:EVENT] ?	

SCPI Commands

Command	Parameter
:STATus	
:OPERation	
:PTRansition	<numeric_value>
:NTRansition	<numeric_value>
:PRESet	
:QUEStionable	
:CONDition?	
:ENABle	<numeric_value>
[:EVENT]?	
:PTRansition	<numeric_value>
:NTRansition	<numeric_value>

<numeric_value> can be a decimal integer, hexadecimal, octal, or binary value that is the sum of the binary-weighted values for the desired bits.

Register

Bit	15	14	13	12	11	10	9	8	7	6	5	4	3	2	1	0
Status	1	0	1	1	0	1	1	1	1	1	1	0	0	0	0	0

Decimal	$47072 = 2^{15} + 2^{13} + 2^{12} + 2^{10} + 2^9 + 2^8 + 2^7 + 2^6 + 2^5$
Binary	#B1011011111100000
Octal	$\begin{array}{cccccc} 001 & 011 & 011 & 111 & 100 & 000 \\ \hline & & & & & \\ \text{\#Q} & 1 & 3 & 3 & 7 & 4 & 0 \end{array}$
Hexadecimal	$\begin{array}{cccc} 1011 & 0111 & 1110 & 0000 \\ \hline & & & & \\ \text{\#H} & B & 7 & E & 0 \end{array}$

:STATus:EMERgency:ENABle

This command sets the event enable (MASK) for the Emergency Status "EVENT" register. 1 enables a bit, and 0 disables a bit.

Enabled "EVENT" bits are ORed together, then reported to Bit0 of the Status Byte Register.

Syntax :STATus:EMERgency:ENABle *register*

Parameter

Parameter	Type	Explanation
<i>register</i>	numeric or non-decimal numeric	decimal integer, hexadecimal, octal, or binary value that is the sum of the binary-weighted values for the desired bits.

Query response *register* <newline><^END>

register is a decimal integer value, which is the sum of the binary-weighted values, in NRI response data format.

Example

```
OUTPUT @Hp4155;":STAT:EMER:ENAB 16384"
OUTPUT @Hp4155;":STAT:EMER:ENAB #H4000"
OUTPUT @Hp4155;":STAT:EMER:ENAB #Q40000"
OUTPUT @Hp4155;":STAT:EMER:ENAB #B1000000000000000"

OUTPUT @Hp4155;":STAT:EMER:ENAB?"
ENTER @Hp4155;A
```

:STATus:EMERgency[:EVENT]?

This command returns the present status of the Emergency Status "EVENT" register.

Reading this register clears it.

This command has query form *only*.

Syntax :STATus:EMERgency [:EVENT] ?

Query response *register* <newline><^END>

register is a decimal integer value, which is the sum of the binary-weighted values, in NRI response data format.

Example

```
OUTPUT @Hp4155;":EMER:EMER?"
ENTER @Hp4155;A
```

SCPI Commands
:STATus:MEASurement:ENABLE

:STATus:MEASurement:ENABLE

This command sets the event enable (MASK) for the Measurement/Stress Status "EVENT" register. 1 enables a bit, and 0 disables a bit.

Enabled "EVENT" bits are ORed together, then reported to Bit1 of the Status Byte register.

Syntax :STATus:MEASurement:ENABLE *register*

Parameter

Parameter	Type	Explanation
<i>register</i>	numeric or non-decimal numeric	decimal integer, hexadecimal, octal, or binary value that is the sum of the binary-weighted values for the desired bits.

Query response *register* <newline><^END>

register is a decimal integer value, which is the sum of the binary-weighted values, in NR1 response data format.

Example

```
OUTPUT @Hp4155;":STAT:MEAS:ENAB 15"  
OUTPUT @Hp4155;":STAT:MEAS:ENAB #H000F"  
OUTPUT @Hp4155;":STAT:MEAS:ENAB #Q00000017"  
OUTPUT @Hp4155;":STAT:MEAS:ENAB #B000000000001111"  
  
OUTPUT @Hp4155;":STAT:MEAS:ENAB?"  
ENTER @Hp4155;A
```

:STATus:MEASurement[:EVENT]?

This command returns the present status of the Measurement/Stress Status "EVENT" register. Reading this register clears it.

This command has query form *only*.

Syntax :STATus:MEASurement [:EVENT] ?

Query response *register* <newline><^END>

register is a decimal integer value, which is the sum of the binary-weighted values, in NR1 response data format.

Example

```
OUTPUT @Hp4155;":STAT:MEAS?"  
ENTER @Hp4155;A
```

:STATus:OPERation:CONDition?

This command returns the present status of the Operation Status "CONDITION" register. Reading this register does *not* clear it.

This command has query form *only*.

Syntax :STATus:OPERation:CONDition?

Query response *register* <newline><^END>

register is a decimal integer value, which is the sum of the binary-weighted values, in NR1 response data format.

Example
 OUTPUT @Hp4155;":STAT:OPER:COND?"
 ENTER @Hp4155;A

:STATus:OPERation:ENABLE

This command sets the event enable (MASK) for the Operation Status "EVENT" register. 1 enables a bit, and 0 disables a bit.

Enabled "EVENT" bits are ORed together, then reported to Bit7 of the Status Byte Register.

Syntax :STATus:OPERation:ENABle *register*

Parameter

Parameter	Type	Explanation
<i>register</i>	numeric or non-decimal numeric	decimal integer, hexadecimal, octal, or binary value that is the sum of the binary-weighted values for the desired bits.

Query response *register* <newline><^END>

register is a decimal integer value, which is the sum of the binary-weighted values, in NR1 response data format.

Example
 OUTPUT @Hp4155;":STAT:OPER:ENAB 16384"
 OUTPUT @Hp4155;":STAT:OPER:ENAB #H4000"
 OUTPUT @Hp4155;":STAT:OPER:ENAB #Q40000"
 OUTPUT @Hp4155;":STAT:OPER:ENAB #B10000000000000000"
 OUTPUT @Hp4155;":STAT:OPER:ENAB?"
 ENTER @Hp4155;A

SCPI Commands
:STATus:OPERation[:EVENT]?

:STATus:OPERation[:EVENT]?

This command returns the present status of the Operation Status "EVENT" register.
Reading this register clears it. This command has query form *only*.

Syntax :STATus:OPERation [:EVENT] ?

Query response *register* <newline><^END>

register is a decimal integer value, which is the sum of the binary-weighted values, in NR1 response data format.

Example
OUTPUT @Hp4155;":STAT:OPER?"
ENTER @Hp4155;A

:STATus:OPERation:NTRansition

This command sets the negative transition filter of the Operation Status "CONDITION" register.

Syntax :STATus:OPERation:NTRansition *register*

Parameter

Parameter	Type	Explanation
<i>register</i>	numeric or non-decimal numeric	decimal integer, hexadecimal, octal, or binary value that is the sum of the binary-weighted values for the desired bits.

Query response *register* <newline><^END>

register is a decimal integer value, which is the sum of the binary-weighted values, in NR1 response data format.

Semantics
If a bit in the negative transition filter is set to 1, then a 1 to 0 transition in the corresponding bit of the Operation Status "CONDITION" register causes a 1 to be written in the corresponding "EVENT" register.

Example
OUTPUT @Hp4155;":STAT:OPER:NTR 16384"
OUTPUT @Hp4155;":STAT:OPER:NTR #H4000"
OUTPUT @Hp4155;":STAT:OPER:NTR #Q40000"
OUTPUT @Hp4155;":STAT:OPER:NTR #B1000000000000000"
OUTPUT @Hp4155;":STAT:OPER:NTR?"
ENTER @Hp4155;A

:STATus:OPERation:PTRansition

This command sets the positive transition filter for the Operation Status "CONDITION" register.

Syntax :STATus:OPERation:PTRansition *register*

Parameter

Parameter	Type	Explanation
<i>register</i>	numeric or non-decimal numeric	decimal integer, hexadecimal, octal, or binary value that is the sum of the binary-weighted values for the desired bits.

Query response *register* <newline><^END>

register is a decimal integer value, which is the sum of the binary-weighted values, in NR1 response data format.

Semantics

If a bit in the positive transition filter is set to 1, then a 0 to 1 transition in the corresponding bit of the Operation Status "CONDITION" register causes a 1 to be written in the corresponding "EVENT" register.

Example

```
OUTPUT @Hp4155;":STAT:OPER:PTR 16384"  
OUTPUT @Hp4155;":STAT:OPER:PTR #H4000"  
OUTPUT @Hp4155;":STAT:OPER:PTR #Q40000"  
OUTPUT @Hp4155;":STAT:OPER:PTR #B100000000000000000000"  
OUTPUT @Hp4155;":STAT:OPER:PTR?"  
ENTER @Hp4155;A
```

:STATus:PRESet

This command presets the event enable (MASK) register and TRANSITION FILTER registers of the Operation Status, Questionable Status, and Emergency Status registers.

This command does not have query form.

Syntax :STATus:PRESet

Example OUTPUT @Hp4155;":STAT:PRES"

SCPI Commands

:STATus:QUEStionable:CONDition?

The preset value of each register as follows:

Register	Filter/Enable	PREset value
OPERation	ENABLE	0s
	PTR	1s
	NTR	0s
QUEStionable	ENABLE	0s
	PTR	1s
	NTR	0s
EMERgency	ENABLE	1s
	PTR	1s
	NTR	0s

:STATus:QUEStionable:CONDition?

This command returns the present status of the Questionable Status "CONDITION" register.

Reading this register does *not* clear it.

This command has query form *only*.

Syntax

:STATus:QUEStionable:CONDition?

Query response

register <newline><^END>

register is a decimal integer value, which is the sum of the binary-weighted values, in NR1 response data format.

Example

```
OUTPUT @Hp4155;":STAT:QUES:COND?"  
ENTER @Hp4155;A
```

:STATus:QUEStionable:ENABle

This command sets the event enable (MASK) for the Questionable Status "EVENT" register. 1 enables a bit, and 0 disables a bit.

Enabled "EVENT" bits are ORed together, then reported to Bit3 of the Status Byte Register.

Syntax :STATus:QUEStionable:ENABle *register*

Parameter

Parameter	Type	Explanation
<i>register</i>	numeric or non-decimal numeric	decimal integer, hexadecimal, octal, or binary value that is the sum of the binary-weighted values for the desired bits.

Query response *register* <newline><^END>

register is a decimal integer value, which is the sum of the binary-weighted values, in NR1 response data format.

Example

```
OUTPUT @Hp4155;":STAT:QUES:ENAB 16384"
OUTPUT @Hp4155;":STAT:QUES:ENAB #H4000"
OUTPUT @Hp4155;":STAT:QUES:ENAB #Q40000"
OUTPUT @Hp4155;":STAT:QUES:ENAB #B1000000000000000"

OUTPUT @Hp4155;":STAT:QUES:ENAB?"
ENTER @Hp4155;A
```

:STATus:QUEStionable[:EVENT]?

This command returns the present status of the Questionable Status "EVENT" register. Reading this register clears it. This command has query form *only*.

Syntax :STATus:QUEStionable [:EVENT] ?

Query response *register* <newline><^END>

register is a decimal integer value, which is the sum of the binary-weighted values, in NR1 response data format.

Example

```
OUTPUT @Hp4155;":STAT:QUES?"
ENTER @Hp4155;A
```

SCPI Commands
:STATus:QUEStionable:NTRansition

:STATus:QUEStionable:NTRansition

This command sets the negative transition filter of the Questionable Status "CONDITION" register.

Syntax :STATus:QUEStionable:NTRansition *register*

Parameter

Parameter	Type	Explanation
<i>register</i>	numeric or non-decimal numeric	decimal integer, hexadecimal, octal, or binary value that is the sum of the binary-weighted values for the desired bits.

Query response *register* <newline><^END>

register is a decimal integer value, which is the sum of the binary-weighted values, in NR1 response data format.

Semantics If a bit in the negative transition filter is set to 1, then a 1 to 0 transition in the corresponding bit of the Questionable Status "CONDITION" register causes a 1 to be written in the corresponding "EVENT" register.

Example

```
OUTPUT @Hp4155;":STAT:QUES:NTR 16384"  
OUTPUT @Hp4155;":STAT:QUES:NTR #H4000"  
OUTPUT @Hp4155;":STAT:QUES:NTR #Q40000"  
OUTPUT @Hp4155;":STAT:QUES:NTR #B10000000000000000"  
OUTPUT @Hp4155;":STAT:QUES:NTR?"  
ENTER @Hp4155;A
```

:STATus:QUEStionable:PTRansition

This command sets the positive transition filter of the Questionable Status "CONDITION" register.

Syntax :STATus:QUEStionable:PTRansition *register*

Parameter

Parameter	Type	Explanation
<i>register</i>	numeric or non-decimal numeric	decimal integer, hexadecimal, octal, or binary value that is the sum of the binary-weighted values for the desired bits.

Query response *register* <newline><^END>

register is a decimal integer value, which is the sum of the binary-weighted values, in NR1 response data format.

Semantics

If a bit in the positive transition filter is set to 1, then a 0 to 1 transition in the corresponding bit of the Questionable Status "CONDITION" register causes a 1 to be written in the corresponding "EVENT" register.

Example

```
OUTPUT @Hp4155;":STAT:QUES:PTR 16384"  
OUTPUT @Hp4155;":STAT:QUES:PTR #H4000"  
OUTPUT @Hp4155;":STAT:QUES:PTR #Q40000"  
OUTPUT @Hp4155;":STAT:QUES:PTR #B10000000000000000"  
OUTPUT @Hp4155;":STAT:QUES:PTR?"  
ENTER @Hp4155;A
```

SYSTEM Subsystem

The SYSTEM subsystem is a collection of functions that are not related to instrument performance.

Examples include functions for performing general housekeeping and functions related to setting global configurations, such TIME or LANGUAGE.

The following table is the command tree of SYSTEM subsystem.

Command	Parameter
:SYSTEM	
:BEEPer	
:STATe	0 1 OFF ON
:CONFig	
:ALL?	
:CREVision?	
:ETHErnet?	
:SLOT?	<slot_number>
:DATE	<year>,<month>,<day>
:ERRor?	
:LANGUage	COMPAtibility
:LFRequency	<numeric_value>
:NTMOut	<second>
:SSAVer	<minute>
:TIME	<hour>,<minute>,<second>
:VERSion?	

Command	Parameter
:SYSTem	
:COMMunicate	
:GPIB	
:RDEvice	
:ADDRESS	<numeric_value>
:NETwork	
:FILEr	
:DELeTe	NET1 NET2 NET3 NET4
:NET	
:DIRectory	<directory>
:IPADdress	<ipaddress>
:NAME	<name>
:SET	NET1 NET2 NET3 NET4
:PRINTer	
:DELeTe	NET1 NET2 NET3 NET4
:NET	
:GRAPhoption	<option>
:IPADdress	<ipaddress>
:NAME	<name>
:TEXToption	<option>
:TYPE	BSD SYSV
:SET	NET1 NET2 NET3 NET4
[:SELF]	
:GATEWay	<ipaddress>
:GROUpid	<id>
:IPADdress	<ipaddress>
:NAME	<name>
:SNETmask	<subnetmask>
:USERid	<id>

SCPI Commands
:SYSTem:BEEPer:STATe

:SYSTem:BEEPer:STATe

This command controls whether the beeper is enabled.

At *RST, this value is ON.

Syntax :SYSTem:BEEPer:STATe OFF | ON | 0 | 1

Parameter

Parameter	Type	Explanation
OFF or 0	boolean	beeper is disabled
ON or 1	boolean	beeper is enabled

Query response 0 | 1 <newline><<^END>

Example
OUTPUT @Hp4155;":SYST:BEEP:STAT ON"
OUTPUT @Hp4155;":SYST:BEEP:STAT?"
ENTER @Hp4155;A

:SYSTem:COMMunicate:GPIB:RDEvice:ADDRESS

This command sets the GPIB bus address of hard copy.

This command does not affect the address of the peripheral device.

The 4155C/4156C sends hard copy data to the device which has specified GPIB bus address.

At *RST, the value of this parameter is 1.

Syntax :SYSTem:COMMunicate:GPIB:RDEvice:ADDRESS *address* | MINimum | MAXimum

Parameter

Parameter	Type	Explanation
<i>address</i>	numeric	0 to 30

Query response *address* <newline><<^END>
address is NR1 response data.

Example

```
OUTPUT @Hp4155;":SYST:COMM:GPIB:RDEV:ADDR 1"
OUTPUT @Hp4155;":SYST:COMM:GPIB:RDEV:ADDR?"
ENTER @Hp4155;A
```

:SYSTem:COMMunicate:NETwork:FILEr:DELeTe

This command deletes the network drive setup.

This command does not have query form.

Syntax

```
:SYSTem:COMMunicate:NETwork:FILEr:DELeTe NET1 | NET2 | NET3 | NET4
```

Parameter

Parameter	Type	Explanation
NET1	character	Specifies register 1 to delete the setup.
NET2	character	Specifies register 2 to delete the setup.
NET3	character	Specifies register 3 to delete the setup.
NET4	character	Specifies register 4 to delete the setup.

Example

```
OUTPUT @Hp4155;":SYST:COMM:NET:FILE:DEL NET1"
```

See also

```
:SYSTem:COMMunicate:NETwork:FILEr:SET
```

SCPI Commands

:SYSTem:COMMunicate:NETwork:FILEr:NET:DIRectory

:SYSTem:COMMunicate:NETwork:FILEr:NET:DIRectory

This command is one of the commands to register the network drive setup. To register a setup, the following commands must be entered:

- :SYSTem:COMMunicate:NETwork:FILEr:NET:NAME
- :SYSTem:COMMunicate:NETwork:FILEr:NET:IPADdress
- :SYSTem:COMMunicate:NETwork:FILEr:NET:DIRectory
- :SYSTem:COMMunicate:NETwork:FILEr:SET

You can register maximum 4 setups.

This command specifies the directory on the NFS server mounted by the 4155C/4156C. The directory is the root directory for the 4155C/4156C.

Confirm that the NFS server exports the directory for the 4155C/4156C.

If you do not enter the :SYST:COMM:NET:FILE:SET command, *RST clears this setting. Query returns the present setting.

Syntax

:SYSTem:COMMunicate:NETwork:FILEr:NET:DIRectory *directory*

Parameter

Parameter	Type	Explanation
<i>directory</i>	string	Directory mounted by the 4155C/4156C

Query response

directory <newline><^END>

Example

```
OUTPUT @Hp4155;":SYST:COMM:NET:FILE:NET:DIR "/TEST/SETUP
'"
OUTPUT @Hp4155;":SYST:COMM:NET:FILE:NET:DIR?"
ENTER @Hp4155;A$
```

:SYSTem:COMMunicate:NETwork:FILEr:NET:IPADdress

This command is one of the commands to register the network drive setup. To register a setup, the following commands must be entered:

- :SYSTem:COMMunicate:NETwork:FILEr:NET:NAME
- :SYSTem:COMMunicate:NETwork:FILEr:NET:IPADdress
- :SYSTem:COMMunicate:NETwork:FILEr:NET:DIRectory
- :SYSTem:COMMunicate:NETwork:FILEr:SET

You can register maximum 4 setups.

This command sets the IP address of your NFS server.

If you do not enter the :SYST:COMM:NET:FILE:SET command, *RST clears this setting. Query returns the present setting.

Syntax

:SYSTem:COMMunicate:NETwork:FILEr:NET:IPADdress *ipaddress*

Parameter

Parameter	Type	Explanation
<i>ipaddress</i>	string	IP address of the NFS server.

Query response

ipaddress <newline><^END>

Example

```
OUTPUT @Hp4155;":SYST:COMM:NET:FILE:NET:IPAD '172.0.0.1'
```

```
OUTPUT @Hp4155;":SYST:COMM:NET:FILE:NET:IPAD?"
ENTER @Hp4155;A$
```

SCPI Commands

:SYSTem:COMMunicate:NETwork:FILEr:NET:NAME

:SYSTem:COMMunicate:NETwork:FILEr:NET:NAME

This command is one of the commands to register the network drive setup. To register a setup, the following commands must be entered:

- :SYSTem:COMMunicate:NETwork:FILEr:NET:NAME
- :SYSTem:COMMunicate:NETwork:FILEr:NET:IPADdress
- :SYSTem:COMMunicate:NETwork:FILEr:NET:DIRectory
- :SYSTem:COMMunicate:NETwork:FILEr:SET

You can register maximum 4 setups.

This command sets the label or name for the network drive setup.

If you do not enter the :SYST:COMM:NET:FILE:SET command, *RST clears this setting. Query returns the present setting.

Syntax

:SYSTem:COMMunicate:NETwork:FILEr:NET:NAME *name*

Parameter

Parameter	Type	Explanation
<i>name</i>	string	Label or name for the network drive setup. Maximum 15 characters.

Query response

hostname <newline><^END>

Example

```
OUTPUT @Hp4155;":SYST:COMM:NET:FILE:NET:NAME 'mydir1'"
OUTPUT @Hp4155;":SYST:COMM:NET:FILE:NET:NAME?"
ENTER @Hp4155;A$
```

:SYSTem:COMMunicate:NETwork:FILEr:SET

This command is one of the commands to register the network drive setup. To register a setup, the following commands must be entered:

- :SYSTem:COMMunicate:NETwork:FILEr:NET:NAME
- :SYSTem:COMMunicate:NETwork:FILEr:NET:IPAddress
- :SYSTem:COMMunicate:NETwork:FILEr:NET:DIRectory
- :SYSTem:COMMunicate:NETwork:FILEr:SET

You can register maximum 4 setups.

This command registers the network drive setup. The setup data is stored in the internal memory. Query returns the present setting.

Syntax

:SYSTem:COMMunicate:NETwork:FILEr:SET NET1 | NET2 | NET3 | NET4

Parameter

Parameter	Type	Explanation
NET1	character	Specifies register 1 to store the setup.
NET2	character	Specifies register 2 to store the setup.
NET3	character	Specifies register 3 to store the setup.
NET4	character	Specifies register 4 to store the setup.

Query response

name, ipaddress, directory <newline><^END>

Example

```
OUTPUT @Hp4155;":SYST:COMM:NET:FILE:SET NET1"  
OUTPUT @Hp4155;":SYST:COMM:NET:FILE:SET? NET2"  
ENTER @Hp4155;A$
```

See also

:SYSTem:COMMunicate:NETwork:FILEr:DELete

SCPI Commands

:SYSTem:COMMunicate:NETwork:PRINter:DELeTe

:SYSTem:COMMunicate:NETwork:PRINter:DELeTe

This command deletes the network printer setup.

This command does not have query form.

Syntax

:SYSTem:COMMunicate:NETwork:PRINter:DELeTe NET1 | NET2 | NET3 | NET4

Parameter

Parameter	Type	Explanation
NET1	character	Specifies register 1 to delete the setup.
NET2	character	Specifies register 2 to delete the setup.
NET3	character	Specifies register 3 to delete the setup.
NET4	character	Specifies register 4 to delete the setup.

Example

OUTPUT @Hp4155;":SYST:COMM:NET:PRIN:DEL NET1"

See also

:SYSTem:COMMunicate:NETwork:PRINter:SET

:SYSTem:COMMunicate:NETwork:PRINter:NET:GRAPhoption

This command is one of the commands to register the network printer setup. To register a printer setup, the following commands must be entered:

- :SYSTem:COMMunicate:NETwork:PRINter:NET:NAME
- :SYSTem:COMMunicate:NETwork:PRINter:NET:IPAdDress
- :SYSTem:COMMunicate:NETwork:PRINter:NET:TEXToption
- :SYSTem:COMMunicate:NETwork:PRINter:NET:GRAPhoption
- :SYSTem:COMMunicate:NETwork:PRINter:NET:TYPE
- :SYSTem:COMMunicate:NETwork:PRINter:SET

You can register maximum 4 setups.

This command sets the graphic output option of *lpr* command which is sent to the remote printer via your print server.

If you do not enter the :SYST:COMM:NET:PRIN:SET command, *RST clears this setting. Query returns the present setting.

Syntax

:SYSTem:COMMunicate:NETwork:PRINter:NET:GRAPhoption *option*

Parameter

Parameter	Type	Explanation
<i>option</i>	string	graphic output option of <i>lpr</i> command.

Query response

option <newline><^END>

Example

```
OUTPUT @Hp4155;":SYST:COMM:NET:PRIN:NET:GRAP '-h-l'"
OUTPUT @Hp4155;":SYST:COMM:NET:PRIN:NET:GRAP?"
ENTER @Hp4155;A$
```

SCPI Commands

:SYSTem:COMMunicate:NETwork:PRINter:NET:IPADdress

:SYSTem:COMMunicate:NETwork:PRINter:NET:IPADdress

This command is one of the commands to register the network printer setup. To register a printer setup, the following commands must be entered:

- :SYSTem:COMMunicate:NETwork:PRINter:NET:NAME
- :SYSTem:COMMunicate:NETwork:PRINter:NET:IPADdress
- :SYSTem:COMMunicate:NETwork:PRINter:NET:TEXToption
- :SYSTem:COMMunicate:NETwork:PRINter:NET:GRAPHoption
- :SYSTem:COMMunicate:NETwork:PRINter:NET:TYPE
- :SYSTem:COMMunicate:NETwork:PRINter:SET

You can register maximum 4 setups.

This command sets the IP address of the print server.

If you do not enter the :SYST:COMM:NET:PRIN:SET command, *RST clears this setting. Query returns the present setting.

Syntax

:SYSTem:COMMunicate:NETwork:PRINter:NET:IPADdress *ipaddress*

Parameter

Parameter	Type	Explanation
<i>ipaddress</i>	string	IP address of the print server.

Query response

ipaddress <newline><^END>

Example

```
OUTPUT @Hp4155;":SYST:COMM:NET:PRIN:NET:IPAD '172.0.0.2'
```

```
OUTPUT @Hp4155;":SYST:COMM:NET:PRIN:NET:IPAD?"  
ENTER @Hp4155;A$
```

:SYSTem:COMMunicate:NETwork:PRINter:NET:NAME

:SYSTem:COMMunicate:NETwork:PRINter:NET:NAME

This command is one of the commands to register the network printer setup. To register a printer setup, the following commands must be entered:

- :SYSTem:COMMunicate:NETwork:PRINter:NET:NAME
- :SYSTem:COMMunicate:NETwork:PRINter:NET:IPADdress
- :SYSTem:COMMunicate:NETwork:PRINter:NET:TEXToption
- :SYSTem:COMMunicate:NETwork:PRINter:NET:GRAPHoption
- :SYSTem:COMMunicate:NETwork:PRINter:NET:TYPE
- :SYSTem:COMMunicate:NETwork:PRINter:SET

You can register maximum 4 setups.

This command sets the printer name assigned to the remote printer, and defined on the print server.

If you do not enter the :SYST:COMM:NET:PRIN:SET command, *RST clears this setting. Query returns the present setting.

Syntax

:SYSTem:COMMunicate:NETwork:PRINter:NET:NAME *name*

Parameter

Parameter	Type	Explanation
<i>name</i>	string	Printer name assigned to the printer. Maximum 15 characters. The name must be defined on the print server.

Query response

printer_name <newline><^END>

Example

```
OUTPUT @Hp4155;":SYST:COMM:NET:PRIN:NET:NAME 'printer1'"
OUTPUT @Hp4155;":SYST:COMM:NET:PRIN:NET:NAME?"
ENTER @Hp4155;A$
```

:SYSTem:COMMunicate:NETwork:PRINter:NET:TEXToption

:SYSTem:COMMunicate:NETwork:PRINter:NET:TEXToption

This command is one of the commands to register the network printer setup. To register a printer setup, the following commands must be entered:

- :SYSTem:COMMunicate:NETwork:PRINter:NET:NAME
- :SYSTem:COMMunicate:NETwork:PRINter:NET:IPADdress
- :SYSTem:COMMunicate:NETwork:PRINter:NET:TEXToption
- :SYSTem:COMMunicate:NETwork:PRINter:NET:GRAPhoption
- :SYSTem:COMMunicate:NETwork:PRINter:NET:TYPE
- :SYSTem:COMMunicate:NETwork:PRINter:SET

You can register maximum 4 setups.

This command sets the text output option of *lpr* command which is sent to a remote printer via your print server.

If you do not enter the :SYST:COMM:NET:PRIN:SET command, *RST clears this setting. Query returns the present setting.

Syntax:SYSTem:COMMunicate:NETwork:PRINter:NET:TEXToption *option***Parameter**

Parameter	Type	Explanation
<i>option</i>	string	Text output option of lpr command.

Query response*option* <newline><^END>**Example**

```
OUTPUT @Hp4155;":SYST:COMM:NET:PRIN:NET:TEXT '-h'"
OUTPUT @Hp4155;":SYST:COMM:NET:PRIN:NET:TEXT?"
ENTER @Hp4155;A$
```

:SYSTem:COMMunicate:NETwork:PRINter:NET:TYPE

This command is one of the commands to register the network printer setup. To register a printer setup, the following commands must be entered:

- :SYSTem:COMMunicate:NETwork:PRINter:NET:NAME
- :SYSTem:COMMunicate:NETwork:PRINter:NET:IPAdDress
- :SYSTem:COMMunicate:NETwork:PRINter:NET:TEXToption
- :SYSTem:COMMunicate:NETwork:PRINter:NET:GRAPhoption
- :SYSTem:COMMunicate:NETwork:PRINter:NET:TYPE
- :SYSTem:COMMunicate:NETwork:PRINter:SET

You can register maximum 4 setups.

This command sets the type of the print server (BSD or System V).

If you do not enter the :SYST:COMM:NET:PRIN:SET command, *RST clears this setting. Query returns the present setting.

Syntax

:SYSTem:COMMunicate:NETwork:PRINter:NET:TYPE BSD | SYSV

Parameter

Parameter	Type	Explanation
BSD	character	BSD format
SYSV	character	System V format

Query response

BSD | SYSV <newline><^END>

Example

```
OUTPUT @Hp4155;":SYST:COMM:NET:PRIN:NET:TYPE BSD"
OUTPUT @Hp4155;":SYST:COMM:NET:PRIN:NET:TYPE?"
ENTER @Hp4155;A$
```

SCPI Commands

:SYSTem:COMMunicate:NETwork:PRINter:SET

:SYSTem:COMMunicate:NETwork:PRINter:SET

This command is one of the commands to register the network printer setup. To register a printer setup, the following commands must be entered:

- :SYSTem:COMMunicate:NETwork:PRINter:NET:NAME
- :SYSTem:COMMunicate:NETwork:PRINter:NET:IPAdDress
- :SYSTem:COMMunicate:NETwork:PRINter:NET:TEXToption
- :SYSTem:COMMunicate:NETwork:PRINter:NET:GRAPhoption
- :SYSTem:COMMunicate:NETwork:PRINter:NET:TYPE
- :SYSTem:COMMunicate:NETwork:PRINter:SET

You can register maximum 4 setups.

This command registers the network printer setup. The setup is stored in the internal memory. Query returns the present setting.

Syntax

:SYSTem:COMMunicate:NETwork:PRINter:SET NET1 | NET2 | NET3 | NET4

Parameter

Parameter	Type	Explanation
NET1	character	Specifies register 1 to store the setup.
NET2	character	Specifies register 2 to store the setup.
NET3	character	Specifies register 3 to store the setup.
NET4	character	Specifies register 4 to store the setup.

Query response

name, ipaddress, textoption, graphoption, type <newline><^END>

Example

```
OUTPUT @Hp4155;":SYST:COMM:NET:PRIN:SET NET1"  
OUTPUT @Hp4155;":SYST:COMM:NET:PRIN:SET? NET2"  
ENTER @Hp4155;A$
```

See also

:SYSTem:COMMunicate:NETwork:PRINter:DELEte

:SYSTem:COMMunicate:NETwork[:SELF]:GATEway

This command sets the IP address of the gateway used for access outside the 4155C/4156C subnet.

The *RST command has no effect on the value of this parameter. The query returns the present setting.

Syntax

:SYSTem:COMMunicate:NET [:SELF]:GATEway *ipaddress*

:SYSTem:COMMunicate:NET [:SELF]:GATEway?

Parameter

Parameter	Type	Explanation
<i>ipaddress</i>	string	IP address of the gateway. String of up to 15 characters. A value of 0.0.0.0 disables this function.

Query response

ipaddress <newline><^END>

Example

```
OUTPUT @Hp4155;":SYST:COMM:NET:GATE '127.0.2.52'"  
OUTPUT @Hp4155;":SYST:COMM:NET:GATE?"  
ENTER @Hp4155;A$
```

SCPI Commands

:SYSTem:COMMunicate:NETwork[:SELF]:GROUpid

:SYSTem:COMMunicate:NETwork[:SELF]:GROUpid

This command is one of the commands to register the 4155C/4156C network setup. To register the 4155C/4156C network setup, enter the following commands:

- :SYSTem:COMMunicate:NETwork[:SELF]:NAME
- :SYSTem:COMMunicate:NETwork[:SELF]:IPADdress
- :SYSTem:COMMunicate:NETwork[:SELF]:USERid
- :SYSTem:COMMunicate:NETwork[:SELF]:GROUpid

This command sets your group ID.

*RST sets the value to 100. Query returns the present setting.

Syntax

:SYSTem:COMMunicate:NETwork [:SELF] :GROUpid *id*

Parameter

Parameter	Type	Explanation
<i>id</i>	numeric	ID number. 1 to 32767.

Query response

id <newline><^END>

id is NR1 response data.

Example

OUTPUT @Hp4155;":SYST:COMM:NET:SELF:GROU 55"

OUTPUT @Hp4155;":SYST:COMM:NET:SELF:GROU?"

ENTER @Hp4155;A

:SYSTem:COMMunicate:NETwork[:SELF]:IPADdress

This command is one of the commands to register the 4155C/4156C network setup. To register the 4155C/4156C network setup, enter the following commands:

- :SYSTem:COMMunicate:NETwork[:SELF]:NAME
- :SYSTem:COMMunicate:NETwork[:SELF]:IPADdress
- :SYSTem:COMMunicate:NETwork[:SELF]:USERid
- :SYSTem:COMMunicate:NETwork[:SELF]:GROUpid

This command sets the IP address assigned to the 4155C/4156C.

*RST has no effect on the value of this parameter. Query returns the present setting.

Syntax

:SYSTem:COMMunicate:NETwork [:SELF] :IPADdress *ipaddress*

Parameter

Parameter	Type	Explanation
<i>ipaddress</i>	string	IP address for the 4155C/4156C.

Query response

IP address <newline><^END>

Example

```
OUTPUT @Hp4155;":SYST:COMM:NET:SELF:IPAD '127.0.0.3'"
OUTPUT @Hp4155;":SYST:COMM:NET:SELF:IPAD?"
ENTER @Hp4155;A$
```

SCPI Commands

:SYSTem:COMMunicate:NETwork[:SELF]:NAME

:SYSTem:COMMunicate:NETwork[:SELF]:NAME

This command is one of the commands to register the 4155C/4156C network setup. To register the 4155C/4156C network setup, enter the following commands:

- :SYSTem:COMMunicate:NETwork[:SELF]:NAME
- :SYSTem:COMMunicate:NETwork[:SELF]:IPAdDress
- :SYSTem:COMMunicate:NETwork[:SELF]:USERid
- :SYSTem:COMMunicate:NETwork[:SELF]:GROUpid

This command sets the host name assigned to the 4155C/4156C.

*RST has no effect on the value of this parameter. Query returns the present setting.

Syntax

:SYSTem:COMMunicate:NETwork [:SELF] :NAME *name*

Parameter

Parameter	Type	Explanation
<i>name</i>	string	Host name for the 4155C/4156C. Maximum 15 characters.

Query response

host_name <newline><^END>

Example

```
OUTPUT @Hp4155;":SYST:COMM:NET:SELF:NAME 'analyzer1'"
OUTPUT @Hp4155;":SYST:COMM:NET:SELF:NAME?"
ENTER @Hp4155;A$
```

:SYSTem:COMMunicate:NETwork[:SELF]:SNETmask

This command sets the subnet mask of the network connection of the 4155C/4156C.

The *RST command has no effect on the value of this parameter. The query returns the present setting.

Syntax

:SYSTem:COMMunicate:NET [:SELF]:SNETmask *subnet*

:SYSTem:COMMunicate:NET [:SELF]:SNETmask?

Parameter

Parameter	Type	Explanation
<i>subnet</i>	string	Subnet mask. String of up to 15 characters. The value 255.255.255.255 is invalid.

When *subnet* = 0.0.0.0 the default value of the class specified by the IP address of the 4155C/4156C is automatically set. The default value is 255.0.0.0 for class A, 255.255.0.0 for class B, or 255.255.255.0 for class C.

You cannot set the subnet mask value for a class higher than the class of the 4155C/4156C.

Query response

subnet <newline><^END>

Example

```
OUTPUT @Hp4155;":SYST:COMM:NET:SNET '255.255.255.0'"
OUTPUT @Hp4155;":SYST:COMM:NET:SNET?"
ENTER @Hp4155;A$
```

SCPI Commands

:SYSTem:COMMunicate:NETwork[:SELF]:USERid

:SYSTem:COMMunicate:NETwork[:SELF]:USERid

This command is one of the commands to register the 4155C/4156C network setup. To register the 4155C/4156C network setup, enter the following commands:

- :SYSTem:COMMunicate:NETwork[:SELF]:NAME
- :SYSTem:COMMunicate:NETwork[:SELF]:IPADdress
- :SYSTem:COMMunicate:NETwork[:SELF]:USERid
- :SYSTem:COMMunicate:NETwork[:SELF]:GROUpid

This command sets your user ID.

*RST sets the value to 200. Query returns the present setting.

Syntax

:SYSTem:COMMunicate:NETwork [:SELF] :USERid *id*

Parameter

Parameter	Type	Explanation
<i>id</i>	numeric	ID number. 1 to 32767.

Query response

id <newline><^END>

id is NR1 response data.

Example

OUTPUT @Hp4155;":SYST:COMM:NET:SELF:USER 4156"

OUTPUT @Hp4155;":SYST:COMM:NET:SELF:USER?"

ENTER @Hp4155;A

:SYSTem:CONFig:ALL?

This command returns the name and revision of all modules installed in the 4155C/4156C. This command has only a query form.

Syntax :SYSTem:CONFig:ALL?

Query response *slot0; slot1; slot2; slot3; slot4; slot5; slot6; slot7; slot8* <newline><^END>
where, *slotN* (*N*: integer. 0 to 8.) = *name,revision*

Response	Type	Explanation		
<i>name</i>	string	module name.	<i>name</i>	description
			SMU:MP	MPSMU
			SMU:HR	HRSMU
			SMU:HP	HPSMU
			VSVMU	VSVMU
			VSVMU:HR	HRVSVMU
			PGU	PGU
			GNDU	GNDU
			NONE	Not installed in this slot.
			UNK	Module unknown.
<i>revision</i>	numeric	Hardware revision number of the module. <i>revision</i> is NR1 response data type.		

Example

```
DIM A$[100]
OUTPUT @Hp4155;":SYST:CONF:ALL?"
ENTER @Hp4155;A$
PRINT A$
```

SCPI Commands
:SYSTem:CONFIg:CREVision?

:SYSTem:CONFIg:CREVision?

This command returns the revision number of the CPU board. This command has query form only.

Syntax :SYSTem:CONFIg:CREVision?

Query response *revision* <newline><^END>

revision is an NR1 response data type.

This command returns 1 for the 4155C/4156C CPU board otherwise 0 is returned.

Example
OUTPUT @Hp4155;" :SYST:CONF:CREV?"
ENTER @Hp4155;A

:SYSTem:CONFIg:ETHErnet?

This command returns the ethernet address of the 4155C/4156C. This command has only a query form.

Syntax :SYSTem:CONFIg:ETHErnet?

Query response *address* <newline><^END>

address is string data. A 12 digits hexadecimal number.

If this command cannot read the ethernet address, it returns “-”. If this happens, you cannot use the network function.

Example
OUTPUT @Hp4155;" :SYST:CONF:ETHE?"
ENTER @Hp4155;A\$

:SYSTem:CONFig:SLOT?

This command returns the name and revision of the module specified by *number*.
This command has only a query form.

Syntax

:SYSTem:CONFig:SLOT? *number*

Parameter

Parameter	Type	Explanation
<i>number</i>	numeric	slot number. 0 to 8.

Query response

name,revision <newline><^END>

Response	Type	Explanation		
<i>name</i>	string	module name.	<i>name</i>	description
			SMU:MP	MPSMU
			SMU:HR	HRSMU
			SMU:HP	HPSMU
			VSVMU	VSVMU
			VSVMU:HR	HRVSVMU
			PGU	PGU
			GNDU	GNDU
			NONE	Not installed in this slot.
			UNK	Module unknown.
<i>revision</i>	numeric	Hardware revision number of the module. <i>revision</i> is NR1 response data type.		

Example

```
DIM A$[15]
OUTPUT @Hp4155;":SYST:CONF:SLOT? 1"
ENTER @Hp4155;A$
PRINT A$
```

SCPI Commands

:SYSTem:DATE

:SYSTem:DATE

This command sets the calendar.

*RST has no effect on the value of this parameter.

Syntax

:SYSTem:DATE *year* | MINimum | MAXimum, *month* | MINimum | MAXimum,
day | MINimum | MAXimum

Parameter

Parameter	Type	Explanation
<i>year</i>	numeric	1900 to 2099
<i>month</i>	numeric	1 to 12
<i>day</i>	numeric	1 to 31

Query response

year, month, day <newline><^END>

year, month, and day are NR1 response data.

Example

```
OUTPUT @Hp4155;":SYST:DATE 1997,9,1"  
OUTPUT @Hp4155;":SYST:DATE?"  
ENTER @Hp4155;A,B,C
```

:SYSTem:ERRor?

This command reads the error from the head of the error queue and removes that error from the queue. This command has query form *only*.

Syntax

:SYSTem:ERRor?

Query response

err_no, message <newline><^END>

err_no is numeric response data, and *message* is string response data..

If there has been no error (error queue is empty), the response to this query command is as follows:

0, "Noerror"

Example

```
OUTPUT @Hp4155;":SYST:ERR?"  
ENTER @Hp4155;A,B$
```

:SYSTem:LANGuage

This command performs reset, then switches the remote command language from the 4155/4156 (SCPI) to the 4145B syntax commands mode.

After switching the language to the 4145B syntax commands mode, only the *RST command can switch the language back to SCPI mode.

This command does not have query form.

At *RST, the remote command language is SCPI.

Syntax :SYSTem:LANGuage COMPatibility

Parameter

Parameter	Type	Explanation
COMPatibility	character	4145B syntax commands

Example OUTPUT @Hp4155;":SYST:LANG COMP"

:SYSTem:LFRequency

This command sets or queries the value that is set for the power line frequency (reference frequency). *RST has no effect on the value of this parameter.

Syntax :SYSTem:LFRequency *frequency*

Parameter

Parameter	Type	Explanation
<i>frequency</i>	numeric	50 or 60 (Hz)

"HZ" suffix can be used after *frequency*.

Query response *frequency* <newline><^END>

frequency is NR3 response data.

Example
OUTPUT @Hp4155;":SYST:LFR 50"
OUTPUT @Hp4155;":SYST:LFR 50HZ"

SCPI Commands
:SYSTem:NTMOut

:SYSTem:NTMOut

This command sets the maximum time allowed to establish the connection with the print server defined by the :SYST:COMM:NET:PRIN commands. The 4155C/4156C waits for the response from the printer server when the 4155C/4156C requests hardcopy.

If the 4155C/4156C does not receive the response within the time specified by this command, the 4155C/4156C occurs the timeout error.

*RST sets this parameter to 300 seconds. Query returns the present setting.

Syntax

:SYSTem:NTMOut *second*

Parameter

Parameter	Type	Explanation
<i>second</i>	numeric	Time to wait for the response from the print server. 1 to 32767 seconds in 1 second step.

Query response

second <newline><^END>

second is NR1 response data.

Example

```
OUTPUT @Hp4155;":SYST:NTMO 100"
```

```
OUTPUT @Hp4155;":SYST:NTMO?"  
ENTER @Hp4155;A
```

See also

:SYSTem:COMMunicate:NETwork:PRINter:NET commands
:SYSTem:COMMunicate:NETwork:PRINter:SET

:SYSTem:SSAVer

This command sets the time until the screen saver works.

*RST sets this parameter to 30 minutes. Query returns the present setting.

Syntax

:SYSTem:SSAVer *minute*

Parameter

Parameter	Type	Explanation
<i>minute</i>	numeric	Time until the screen saver works. 0 to 60 minutes in 1 minute step. 0 disables the screen saver.

Query response

minute <newline><^END>

minute is NR1 response data.

Example

```
OUTPUT @Hp4155;":SYST:SSAV 10"
```

```
OUTPUT @Hp4155;":SYST:SSAV?"
```

```
ENTER @Hp4155;A
```

SCPI Commands

:SYSTem:TIME

:SYSTem:TIME

This command sets the clock.

*RST has no effect on the value of this parameter.

Syntax

:SYSTem:TIME *hour* | MINimum | MAXimum, *minute* | MINimum | MAXimum, *second* | MINimum | MAXimum

Parameter

Parameter	Type	Explanation
<i>hour</i>	numeric	0 to 23
<i>minute</i>	numeric	0 to 59
<i>second</i>	numeric	0 to 60

Query response

hour, minute, second <newline><^END>

hour, minute, and second are NR1 response data.

Example

```
OUTPUT @Hp4155;":SYST:TIME 10,5,8"
```

```
OUTPUT @Hp4155;":SYST:TIME?"
```

```
ENTER @Hp4155;A,B,C
```

:SYSTem:VERSion?

This command returns the SCPI version number for which the current 4155C/4156C complies.

This command has query form *only*.

Syntax :SYSTem:VERSion?

Query response YYYY.V <newline><^END>

YYYY.V is string response data, but does not contain double quote at beginning and end of the string.

YYYY is the year-version (for example 1997), and V is the approved revision number for that year.

If no approved revisions are claimed, then this extension is 0.

Example
OUTPUT @Hp4155;":SYST:VERS?"
ENTER @Hp4155;A\$

SCPI Commands
:SYSTem:VERsion?

6 **Error Messages**

Error Messages

This chapter shows the error code/messages returned when any error occurred during a SCPI program is executed.

Error Messages are classified by error number as listed in the following table:

Error Range	Error Category
0	No error
-100 to -199	Command Error
-200 to -299	Execution Error
-300 to -399	Device-Dependent Error
-400 to -499	Query Error
1 to 32767	4155C/4156C specific error ^a

- a. For the 4155C/4156C specific error, refer to *If You Have a Problem* manual.

Negative error numbers (Command Error, Execution Error, Device-Dependent Error, Query Error) are standard SCPI errors.

Positive error numbers are the 4155C/4156C specific errors, not standard SCPI errors.

When the 4155C/4156C is in the remote control state, the occurrence of an error (except for error number 0 or Emergency Error) sets the corresponding bit in the Standard Event Status Register. An Emergency Error sets the corresponding bit in the Emergency Status Register.

Error Category	Standard Event Status Register Bit
Command Error	bit5
Execution Error	bit4
Device-Dependent Error	bit3
Query Error	bit2
Emergency Error	(sets Emer. Status register)
4155/4156 Specific Error	bit3

Error number and message are placed in the error queue, which can be read by the `:SYSTem:ERRor?` query command. The error queue is cleared by the common command `*CLS`, and when power is turned on. For these commands, see “SYSTem Subsystem” in Chapter 5 and Chapter 4.

No Error

This message indicates that the 4155C/4156C has no errors.

Error 0

No error

The error queue is completely empty. Every error/event in the queue has been read or the queue was purposely cleared by power-on, *CLS, and so on.

Command Error

If syntax of SCPI command is *not* valid, a `-1XX` error occurs. The error number and message are placed in the error queue, and bit5 of the Standard Event Status Register is set.

A SCPI command consists of a **command header** and zero or more **parameters**. The following are example SCPI commands:

- Subsystem command: `:PAGE:SCON:STAN 1`
`:PAGE:SCON:STAN` is the command header, and `1` is the parameter.
A subsystem command header consists of mnemonics (keywords) separated by colons. Query commands have a question mark (?) at end of last mnemonic.
- Common command: `*SRE 48`
`*SRE` is the command header, and `48` is the parameter.
A common command header consists of an asterisk (*) followed by 3 characters. Query commands have a question mark (?) at end of header.

Error -100

`Command error`

Generic syntax error that cannot be determined more specifically.

Error -101

`Invalid character`

An invalid character for the type of a syntax element was received; for example, a header containing an ampersand.

Error -102

`Syntax error`

An unrecognized command or data type was received; for example, a string was received when the 4155C/4156C does not accept strings.

Error -103

`Invalid separator`

An illegal character was received when a separator was expected; for example, the semicolon was omitted after a program message unit.

Error -104

`Data type error`

An improper data type was received; for example, numeric data was expected but string data was received.

- Error -105** GET not allowed
A group execute trigger was received within a program message.
- Error -108** Parameter not allowed
Too many parameters for the command were received.
- Error -109** Missing parameter
Fewer parameters were received than required for the command.
- Error -110** Command header error
An error was detected in the header. This error message is reported if the 4155C/4156C cannot determine the more specific header errors -111 through -114.
- Error -111** Header separator error
An illegal character for a header separator was received; for example, no white space between the header and parameter.
- Error -112** Program mnemonic too long
A keyword in the command header contains more than twelve characters.
- Error -113** Undefined header
An undefined command header was received; for example, *XYZ.
- Error -114** Header suffix out of range
The value of a numeric suffix attached to a program mnemonic is out of range; for example, :PAGE:CHAN:SMU7:MODE V specifies illegal SMU number 7.
- Error -120** Numeric data error
Numeric (including the nondecimal numeric types) data error. This error message is reported when the 4155C/4156C cannot determine the more specific errors -121 through -128.
- Error -121** Invalid character in number
An invalid character for the data type was received; for example, an alphacharacter was received when the type was decimal numeric.

Error Messages

Command Error

- Error -123** Exponent too large
The magnitude of the exponent was larger than 32000.
- Error -124** Too many digits
The mantissa of a decimal numeric data contained more than 255 digits excluding leading zeros.
- Error -128** Numeric data not allowed
Numeric data is not allowed in this position for this command.
- Error -130** Suffix error
An error was detected in the suffix. This error message is reported if the 4155C/4156C cannot determine the more specific suffix errors -131 through -138.
- Error -131** Invalid suffix
The suffix does not follow the correct syntax or the suffix is inappropriate.
- Error -134** Suffix too long
The suffix contains more than 12 characters.
- Error -138** Suffix not allowed
A suffix was received after a numeric parameter that does not allow suffixes.
- Error -140** Character data error
An error was detected in a character parameter. This error message is reported if the 4155C/4156C cannot determine the more specific errors -141 through -148.
- Error -141** Invalid character data
Either the character parameter contains an invalid character or the particular element received is not valid for the command header.
- Error -144** Character data too long
The character parameter contains more than 12 characters.
- Error -148** Character data not allowed
A character parameter is not allowed for this position.

- Error -150** String data error
An error was detected in a string parameter. This error is reported if the 4155C/4156C cannot determine a more specific error -151 and -158.
- Error -151** Invalid string data
An invalid string parameter data was received; for example, an END message was received before the terminal quote character.
- Error -158** String data not allowed
A string parameter data was received but was not allowed at this point.
- Error -160** Block data error
An error was detected in a block data. This error is reported if the 4155C/4156C cannot determine more specific errors -161 and -168.
- Error -161** Invalid block data
An invalid block data was received; for example, an END message was received before the length was satisfied.
- Error -168** Block data not allowed
A legal block data was received but was not allowed at this point.
- Error -170** Expression error
An error was detected in an expression. This error is reported if the 4155C/4156C cannot determine more specific errors -171 and -178.
- Error -171** Invalid expression
The expression was invalid; for example, unmatched parentheses or an illegal character.
- Error -178** Expression data not allowed
An expression was received but was not allowed at this point.

Execution Error

The 4155C/4156C reports -2XX errors when it is unable to perform a valid programming command.

- Error -200** Execution error
- Generic execution error for the 4155C/4156C that cannot be determined more specifically.
- Error -201** Invalid while in local
- A command is not executable while the 4155C/4156C is in local mode due to a Hard Local Control.
- Error -202** Settings lost due to rtl
- A setting associated with a Hard Local Control was lost when the 4155C/4156C changed to Local State (LOCS) from Remote State (REMS) or to Local with Lockout State (LWLS) from Remote with Lockout State (RWLS).
- Error -210** Trigger error
- Error -211** Trigger ignored
- A GET(Group Execution Trigger), *TRG, or triggering signal was received and recognized by the 4155C/4156C but was ignored because of timing considerations; for example, the 4155C/4156C was not ready to respond.
- Error -214** Trigger deadlock
- The trigger source for the initiation of a measurement is set to GET (Group Execution Trigger) and subsequent measurement query is received. The measurement cannot be started until a GET is received.
- Error -220** Parameter error
- A parameter related error occurred and the 4155C/4156C cannot determine the more specific errors -221 through -224.
- Error -221** Settings conflict
- A specified parameter setting could not be executed due to the present device state.

- Error -222** Data out of range
Interpreted value of the program was out of range as defined by the 4155C/4156C.
- Error -223** Too much data
Too many parameters for the 4155C/4156C was received.
- Error -224** Illegal parameter value
Illegal parameter value was received.
- Error -230** Data corrupt or stale
Possibly invalid data; new reading started but not completed since last access.
- Error -231** Data questionable
Measurement accuracy is suspect.
- Error -240** Hardware error
A hardware problem in the 4155C/4156C. This error message is reported if the 4155C/4156C cannot detect the more specific error -241.
- Error -241** Hardware missing
A program command or query could not be executed because of missing hardware; for example, an option was not installed.
- Error -250** Mass storage error
A mass storage error occurred. This error message is reported if the 4155C/4156C cannot determine the more specific errors -251 through -258.
- Error -251** Missing mass storage
A program command or query could not be executed because of missing mass storage.
- Error -252** Missing media
A program command or query could not be executed because of a missing media.

Error Messages

Execution Error

- Error -253** Corrupt media
- A program command or query could not be executed because of corrupt media; for example, bad disk or wrong format.
- Error -254** Media full
- A program command or query could not be executed because the media was full; for example, there is no room on the disk.
- Error -256** File name not found
- A program command or query could not be executed because the file name on the disk was not found.
- Error -257** File name error
- A program command or query could not be executed because the file name on the disk was in error.
- Error -258** Media protected
- A program command or query could not be executed because the media was protected.
- Error -260** Expression error
- An expression related error occurred. This error message is reported if the 4155C/4156C cannot detect the more specific error -261.
- Error -261** Math error in expression
- An expression could not be executed due to a math error; for example, a divide-by-zero was attempted.

Device-Dependent Error

-3XX errors indicate that the 4155C/4156C has detected an error that is not a command error, a query error, or an execution error; some device operations did not properly complete, possibly due to an abnormal hardware or firmware condition. These codes are also used for self-test response errors.

Error -300

Device-specific error

Generic device-dependent error for the 4155C/4156C that cannot be determined more specifically.

Error -310

System error

Some error, termed "system error" by the 4155C/4156C, has occurred.

Error -311

Memory error

An error was detected in the 4155C/4156C's memory.

Error -313

Calibration memory lost

Nonvolatile data saved by the *CAL? command has been lost.

Error -315

Configuration memory lost

Nonvolatile configuration data saved by the 4155C/4156C has been lost.

Error -330

Self-test failed

The self-test has failed.

Error -350

Queue overflow

This code is entered into the queue instead of the code that caused the error. This code indicates that there is no room in the queue and an error occurred but was not recorded.

Query Error

If the output queue control of the 4155C/4156C detects one of following problems, a -4XX error occurs:

- An attempt was made to read data from the output queue when no output data is present or pending.
- Data in the output queue has been lost.

If this type of error occurs, the error number and message are placed in the error queue, and bit2 of the Standard Event Status Register is set.

Error -400

Query error

Generic query error for the 4155C/4156C that cannot be determined more specifically.

Error -410

Query INTERRUPTED

A condition causing an INTERRUPTED query error occurred; for example, a query followed by DAB or GET before a response was completely sent.

Error -420

Query UNTERMINATED

A condition causing an UNTERMINATED query error occurred; for example, the 4155C/4156C was addressed to talk and an incomplete program message was received.

Error -430

Query DEADLOCKED

A condition causing a DEADLOCKED query error occurred; for example, both input buffer and output buffer are full and the 4155C/4156C cannot continue.

Error -440

Query UNTERMINATED after indefinite response

A query was received in the same program message after a query requesting an indefinite length response was executed.