

HP 4396A Network/Spectrum Analyzer
HP-IB Command Reference

SERIAL NUMBERS

This manual applies directly to instruments which has the serial number prefix 3413J, or firmware revision 3.0 or later. For additional important information about serial numbers, read "Serial Number" in Appendix A.



HP Part No. 04396-90004
Printed in JAPAN March 1994

Notice

The information contained in this document is subject to change without notice.

This document contains proprietary information that is protected by copyright. All rights are reserved. No part of this document may be photocopied, reproduced, or translated to another language without the prior written consent of the Hewlett-Packard Company.

Yokogawa-Hewlett-Packard, LTD.
Kobe Instrument Division
1-3-2, Murotani, Nishi-ku, Kobe-shi,
Hyogo, 651-22 Japan

Manual Printing History

The manual printing date and part number indicate its current edition. The printing date changes when a new edition is printed. (Minor corrections and updates that are incorporated at reprint do not cause the date to change.) The manual part number changes when extensive technical changes are incorporated.

December 1992. . . . First Edition

March 1993. . . . Second Edition

March 1994. . . . Third Edition

Safety Summary

The following general safety precautions must be observed during all phases of operation, service, and repair of this instrument. Failure to comply with these precautions or with specific **WARNINGS** given elsewhere in this manual violates safety standards of design, manufacture, and intended use of the instrument.

The Hewlett-Packard Company assumes no liability for the customer's failure to comply with these requirements.

Ground The Instrument

This is a Safety Class 1 product (provided with a protective earth terminal). An uninterruptible safety earth ground must be provided from the main power source to the product input wiring terminals, power source to the product input wiring terminals, power cord, or supplied power cord set. Whenever it is likely that the protection has been impaired, the product must be made inoperative and secured against any unintended operation.

DO NOT Operate In An Explosive Atmosphere

Do not operate the instrument in the presence of flammable gasses or fumes. Operation of any electrical instrument in such an environment constitutes a safety hazard.

Keep Away From Live Circuits

Operating personnel must not remove instrument covers. Component replacement and internal adjustments must be made by qualified maintenance personnel. Do not replace components with the power cable connected. Under certain conditions, dangerous voltages may exist even with the power cable removed. To avoid injuries, always disconnect power and discharge circuits before touching them.

DO NOT Service Or Adjust Alone

Do not attempt internal service or adjustment unless another person, capable of rendering first aid and resuscitation, is present.

DO NOT Substitute Parts Or Modify Instrument

Because of the danger of introducing additional hazards, do not substitute parts or perform unauthorized modifications to the instrument. Return the instrument to a Hewlett-Packard Sales and Service Office for service and repair to ensure the safety features are maintained.

Dangerous Procedure Warnings

Warnings, such as the example below, precede potentially dangerous procedures throughout this manual. Instructions contained in the warnings must be followed.

Warning



Dangerous voltages, capable of causing death, are present in this instrument. Use extreme caution when handling, testing, and adjusting this instrument.

Typeface Conventions

- Bold** Boldface type is used when a term is defined. For example: **icons** are symbols.
- Italics* Italic type is used for emphasis and for titles of manuals and other publications.
- Italic type is also used for keyboard entries when a name or a variable must be typed in place of the words in italics. For example: *copy filename* means to type the word *copy*, to type a space, and then to type the name of a file such as *file1*.
- Computer** Computer font is used for on-screen prompts and messages.
- HARDKEYS** Labeled keys on the instrument front panel are enclosed in □.
- SOFTKEYS** Softkeys located to the right of the CRT are enclosed in ◻.

Certification

Hewlett-Packard Company certifies that this product met its published specifications at the time of shipment from the factory. Hewlett-Packard further certifies that its calibration measurements are traceable to the United States National Institute of Standards and Technology, to the extent allowed by the Institution's calibration facility, or to the calibration facilities of other International Standards Organization members.

Warranty

This Hewlett-Packard instrument product is warranted against defects in material and workmanship for a period of one year from the date of shipment, except that in the case of certain components listed in *Specifications of Function Reference*, the warranty shall be for the specified period. During the warranty period, Hewlett-Packard Company will, at its option, either repair or replace products which prove to be defective.

For warranty service or repair, this product must be returned to a service facility designated by HP. Buyer shall prepay shipping charges to HP and HP shall pay shipping charges to return the product to Buyer. However, Buyer shall pay all shipping charges, duties, and taxes for products returned to HP from another country.

HP warrants that its software and firmware designated by HP for use with an instrument will execute its programming instruction when properly installed on that instrument. HP does not warrant that the operation of the instrument, or software, or firmware will be uninterrupted or error free.

Limitation Of Warranty

The foregoing warranty shall not apply to defects resulting from improper or inadequate maintenance by Buyer, Buyer-supplied software or interfacing, unauthorized modification or misuse, operation outside of the environmental specifications for the product, or improper site preparation or maintenance.

No other warranty is expressed or implied. HP specifically disclaims the implied warranties of merchantability and fitness for a particular purpose.

Exclusive Remedies

The remedies provided herein are buyer's sole and exclusive remedies. HP shall not be liable for any direct, indirect, special, incidental, or consequential damages, whether based on contract, tort, or any other legal theory.

Assistance

Product maintenance agreements and other customer assistance agreements are available for Hewlett-Packard products.

For any assistance, contact your nearest Hewlett-Packard Sales and Service Office. Addresses are provided at the back of this manual.

Safety Symbols

General definitions of safety symbols used on equipment or in manuals.



Instruction manual symbol: the product is marked with this symbol when it is necessary for the user to refer to the instruction manual in order to protect against damage to the instrument.



Indicates dangerous voltage (terminals fed from the interior by voltage exceeding 1000 volts must be so marked).

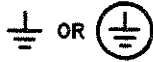

Protective conductor terminal. For protection against electrical shock in case of a fault. Used with wiring terminals to indicate the terminal which must be connected to ground before operating equipment.



Low-noise or noiseless, clean ground (earth) terminal. Used for a signal common, as well as providing protection against electrical shock in case of fault. A terminal marked with this symbol must be connected to ground in the manner described in the installation (Operation) manual, and before operating the equipment.

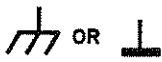

Frame or chassis terminal. A connection to the frame (chassis) of the equipment which normally includes all exposed metal structures.



Alternating current (power line).



Direct current (power line).



Alternating or direct current (power line).

Warning



Warning denotes a hazard. It calls attention to a procedure, practice, condition or the like, which, if not correctly performed or adhered to, could result in injury or death to personnel.

Caution



Caution sign denotes a hazard. It calls attention to a procedure, practice, condition or the like, which, if not correctly performed or adhered to, could result damage to or destruction of part or all of the product.

Note



Note denotes important information. It calls attention to a procedure, practice, condition or the like, which is essential to highlight.

Documentation Map

The following manuals are available for the analyzer.

User's Guide (HP Part Number 04396-90001)

The User's Guide walks you through system setup and initial power-on, shows you how to make basic measurements, explains commonly used features, and contains typical application measurement examples. After you receive your analyzer, begin with this manual.

Task Reference (HP Part Number 04396-90000)

The Task Reference helps you to learn how to use the analyzer. This manual provides simple step-by-step instructions without concepts.

Function Reference (HP Part Number 04396-90002)

The Function Reference describes all functions accessed from the front panel keys and softkeys. It also provides information on options and accessories available, specifications, system performance, and conceptual information about the analyzer's features.

Option 010 Operating Handbook (HP Part Number 04396-90006)

The Operating Handbook describes operations and functions which are unique to the impedance analyzer mode.

HP-IB Programming Guide (HP Part Number 04396-90003)

The HP-IB Programming Guide shows how to write and use BASIC programs to control the analyzer.

HP-IB Command Reference (HP Part Number 04396-90004)

The HP-IB Command Reference provides a summary of all available HP-IB commands. It also provides information on the status reporting structure and the trigger system (these features conform to the SCPI standard).

Using HP Instrument BASIC with the HP 4396A (Option 1C2 only) (HP Part Number 04396-90005)

The Using HP Instrument BASIC with the HP 4396A describes how HP Instrument BASIC works with the analyzer.

HP Instrument BASIC Users Handbook (Option 1C2 only), (HP Part Number E2083-90000)

The HP Instrument BASIC Users Handbook introduces you to the HP Instrument BASIC programming language, provide some helpful hints on getting the most use from it, and provide a general programming reference. It is divided into three books, *HP Instrument BASIC Programming Techniques*, *HP Instrument BASIC Interface Techniques*, and *HP instrument BASIC Language Reference*.

Performance Test Manual (HP Part Number 04396-90100)

The Performance Test Manual provides the tests required to verify that the analyzer conforms to its published specifications.

Service Manual (Option 0BW only), (HP Part Number 04396-90101)

The Service Manual explains how to adjust, troubleshoot, and repair the analyzer.

Contents

1. Introduction	
HP-IB Commands	1-3
Simple Commands	1-3
SCPI Commands	1-3
Common Commands	1-3
SCPI Subsystem Commands	1-3
Subsystem Command Tree	1-4
Command Abbreviations	1-5
Program Message Syntax	1-5
Case	1-5
Program Message Terminator	1-5
Multiple Messages	1-5
Query and Response Message Syntax	1-5
Parameters	1-6
Parameter Types	1-6
2. Commands Reference	
Simple Commands	2-3
ADDRCONT \sqcup <i><numeric></i>	2-3
ADDRPLOT \sqcup <i><numeric></i>	2-3
ADDRPRIN \sqcup <i><numeric></i>	2-3
ANAOCH1	2-4
ANAOCH2	2-4
ANAODATA	2-4
ANAOMEMO	2-4
ANARANG \sqcup <i><numeric1></i> , <i><numeric2></i>	2-5
ANARFULL	2-5
ASCEL \sqcup <i><string></i>	2-5
ATT \sqcup <i><numeric></i> [DB]	2-6
ATTAUTO \sqcup {OFF ON 0 1}	2-6
ATTP1 \sqcup <i><numeric></i> [DB]	2-6
ATTP2 \sqcup <i><numeric></i> [DB]	2-7
AUTO	2-7
AVER \sqcup {OFF ON 0 1}	2-7
AVERFACT \sqcup <i><numeric></i>	2-7
AVERREST	2-8
BACI \sqcup <i><numeric></i> [PCT]	2-8
BEEPDONE \sqcup {OFF ON 0 1}	2-8
BEEPFAIL \sqcup {OFF ON 0 1}	2-8
BEEPWARN \sqcup {OFF ON 0 1}	2-9
BOTV \sqcup <i><numeric></i>	2-9
BW \sqcup <i><numeric></i> [HZ KHZ MAHZ]	2-9
BWAUTO \sqcup {OFF ON 0 1}	2-10
BWSRAT \sqcup <i><numeric></i>	2-10
CO \sqcup <i><numeric></i>	2-11
C1 \sqcup <i><numeric></i>	2-11

C2	<numeric>	2-11
CALCASSI		2-11
CALECPARA		2-12
CALI	{NONE RESP RAI S111 S221 FUL2 ONE2 IMP}	2-12
CALK	{APC7 APC35 N50 N75 USED}	2-13
CALS	<numeric>	2-13
CBRI	<numeric>[PCT]	2-14
CENT	<numeric>[HZ KHZ MAHZ GHZ DBM]	2-14
CHAD	<string>	2-15
CHAN1		2-15
CHAN2		2-15
CIRF	{RI LIN LOG RX GB SWR}	2-16
CLAD		2-16
CLASIMP	{A B C}	2-16
CLASS11	{A B C}	2-17
CLASS22	{A B C}	2-17
CLEL		2-17
CLES		2-17
CNTS	<numeric>[HZ KHZ MAHZ GHZ]	2-17
CNTSAUTO	{OFF ON 0 1}	2-18
COLO	<parameter>	2-18
COLOR	<numeric>[PCT]	2-20
COMC	{A B C}	2-20
COMCDAT	{A B C} <{OFF ON 0 1}>	2-20
COMKDONE		2-21
COMP		2-21
COMS		2-21
COMSDONE		2-21
CONT		2-21
CONV	<parameter>	2-22
COPA		2-22
COPT	{OFF ON 0 1}	2-23
CORR	{OFF ON 0 1}	2-23
COUC	{OFF ON 0 1}	2-24
CRED	<string>	2-24
CRSC	{OFF ON 0 1}	2-25
CWFREQ	<numeric>[HZ KHZ MAHZ GHZ]	2-25
DATAOVAL	<numeric>	2-26
DATGAIN	<numeric>	2-26
DATMEM		2-26
DATOVAL	<numeric>	2-27
DAYYEAR		2-27
DEFC		2-27
DEFEC	{R1 C1 L1 C0} <numeric>	2-28
DEFGO		2-28
DEFS	{1-8}	2-29
DEFSLOAD	{R L} <numeric>	2-29
DEFSOPEN	{G C} <numeric>	2-30
DEFSSHOR	{R L} <numeric>	2-30
DET	{POS NEG SAM}	2-31
DFLT		2-31
DHOLD	{OFF MAX MIN}	2-31
DISA	{ALLI HIHB ALLB BASS}	2-32
DISECIRC		2-33
DISECPARA	{OFF ON 0 1}	2-33

DISF□{DOS LIF}	2-33
DISL	2-34
DISLLIST	2-34
DISMAMP□{UL MD}	2-34
DISMPRM□{STSP CTSP}	2-34
DISP□{DATA MEMO DATM}	2-35
DMKR□{ON FIX TRAC OFF}	2-35
DMKRAUV□<numeric>	2-36
DMKRPRM□<numeric>[HZ KHZ MAHZ GHZ DBM]	2-37
DMKRVAL□<numeric>	2-37
DONE	2-37
DSKEY	2-37
DUAC□{OFF ON 0 1}	2-38
EDITDONE	2-38
EDITLIML	2-38
EDITLIST	2-38
ELED□<numeric>[S MS US NS PS FS]	2-39
ENKEY	2-39
EQUCL□CIR{A B C D E}	2-39
EQU0?□<numeric>	2-40
EQUCPARA?	2-40
EQUCPARS?	2-40
EQUCPARS4?	2-40
EQU?□<numeric>	2-40
ESB?	2-41
ESNB□<numeric>	2-41
EXPP□{OFF ON 0 1}	2-41
FILCL□<string1>,<string2>,<string3>,<string4>	2-42
FIXEL□<numeric>	2-42
FIXKDONE	2-42
FIXTL□{NONE HP16191 HP16192 HP16193 HP16194 USED}	2-42
FMT□<parameter>	2-43
FORM2	2-44
FORM3	2-44
FORM4	2-45
FORM5	2-45
FREQ	2-45
FULS	2-45
FWDI	2-45
FWDM	2-45
FWDT	2-46
GATCTL□{LEV EDG}	2-46
GATDLY□<numeric>[US MS S]	2-46
GATLEN□<numeric>[US MS S]	2-47
GRAEL□<string>	2-47
GRODAPER□<numeric>[PCT]	2-47
HOLD	2-48
INID	2-48
INP8IO?	2-48
INPUCALC{1-12}□<numeric (1)>,<numeric (2)>,...,<numeric (n)>	2-49
INPUCALK□<block>	2-49
INPUCOMC{1 2 3}□<numeric>	2-49
INPUD	2-50
INPUDATA□<numeric (1)>,<numeric (2)>,...,<numeric (n)>	2-50
INPUDTRC□<numeric (1)>,<numeric (2)>,...,<numeric (n)>	2-51

INPULOAA	\sqcup <numeric (1)>,<numeric (2)>, ... ,<numeric (n)>	2-51
INPUOPEAL	\sqcup <numeric (1)>,<numeric (2)>, ... ,<numeric (n)>	2-51
INPURAW	{1-4} \sqcup <numeric (1)>,<numeric (2)>, ... ,<numeric (n)>	2-52
INPUSHOAL	\sqcup <numeric (1)>,<numeric (2)>, ... ,<numeric (n)>	2-52
INPZ	\sqcup {50 75}[OHM]	2-52
INTEL	\sqcup <numeric>[PCT]	2-53
ISOD		2-53
ISOL		2-53
KEY	\sqcup <numeric>	2-53
KITD		2-54
LABECOMK	\sqcup <string>	2-54
LABEFIX	\sqcup <string>	2-54
LABEIMP	{A B C} \sqcup <string>	2-55
LABEFD	{T M} \sqcup <string>	2-55
LABERES	{P I} \sqcup <string>	2-55
LABEREV	{T M} \sqcup <string>	2-56
LABES11	{A B C} \sqcup <string>	2-56
LABES22	{A B C} \sqcup <string>	2-56
LABK	\sqcup <string>	2-57
LABS	\sqcup <string>	2-57
LIMCLEL		2-57
LIMD	\sqcup <numeric>	2-57
LIMEDONE		2-58
LIMIAMPOL	\sqcup <numeric>	2-58
LIMILINEL	{OFF ON 0 1}	2-58
LIMIPRMO	\sqcup <numeric>	2-59
LIMITEST	{OFF ON 0 1}	2-59
LIML	\sqcup <numeric>	2-59
LIMM	\sqcup <numeric>	2-60
LIMPRM	\sqcup <numeric>[HZ KHZ MAHZ GHZ DBM]	2-60
LIMSADD		2-60
LIMSDEL		2-60
LIMSDON		2-60
LIMSEDI	\sqcup <numeric>	2-61
LIMU	\sqcup <numeric>	2-61
LINTDATA	{0-7}	2-61
LINTMEMO	{0-7}	2-62
LMAX?	\sqcup <numeric>	2-62
LMIN?	\sqcup <numeric>	2-62
LISV		2-62
LVCDT	\sqcup <numeric>[DB]	2-63
LVLCAL		2-63
MATH	{DATA DDVM DMNM DPLM}	2-63
MAXMLEV	\sqcup <numeric>[DBM]	2-64
MEAS	\sqcup <parameter>	2-64
MEASTAT	{OFF ON 0 1}	2-67
MKR	{OFF ON 0 1}	2-67
MKRAMPO		2-67
MKRAUV?		2-67
MKRCENT		2-68
MKRCONT	{OFF ON 0 1}	2-68
MKRCOUPL	{OFF ON 0 1}	2-68
MKRCSTE		2-68
MKRDCENT		2-69
MKRDCSTE		2-69

MKRDELA	2-69
MKRDSPAN	2-69
MKRL{OFF ON 0 1}	2-69
MKRMIDD	2-70
MKRNOI{OFF ON 0 1}	2-70
MKRO{DATA MEMO}	2-70
MKROFS	2-70
MKRP<numeric>	2-71
MKRPKD	2-71
MKRPRM<numeric>[HZ KHZ MAHZ GHZ DBM]	2-71
MKRREF	2-71
MKRSTAR	2-72
MKRSTOP	2-72
MKRSWPRM	2-72
MKRTHRE	2-72
MKRTIME{OFF ON 0 1}	2-73
MKRVAL?	2-73
MKRZM	2-73
MODII	2-73
MODICOMK	2-74
MODIFIX	2-74
MONDYEAR	2-74
NA	2-74
NEXP	2-75
NEXPK?	2-75
NUMG<numeric>	2-75
NUMLMAX?	2-76
NUMLMIN?	2-76
OFSD<numeric>[S]	2-76
OFSL<value>	2-76
OFSZ<numeric>[OHM]	2-77
OMII	2-77
OPEP	2-77
OSE<numeric>	2-77
OSER?	2-77
OSNT<numeric>	2-78
OSPT<numeric>	2-78
OSR?	2-78
OUT8IO<numeric>	2-78
OUTPCALC{1-12}?	2-79
OUTPCALK?	2-79
OUTPCERR?	2-79
OUTPCFIL?	2-79
OUTPCOMC{1 2 3}?	2-80
OUTPDATA?	2-80
OUTPDATAP?<numeric>	2-81
OUTPDMKR?	2-81
OUTPDTRC?	2-82
OUTPDTRCP?<numeric>	2-82
OUTPERRO?	2-83
OUTPFAIP?	2-83
OUTPFILT?	2-83
OUTPLIMF?	2-83
OUTPLIML?	2-84
OUTPLIMM?	2-85

OUTPMAX?	2-85
OUTPMEAN?	2-85
OUTPMEMO?	2-85
OUTPMEMOP?□<numeric>	2-86
OUTPMIN?	2-86
OUTPMINMAX?	2-86
OUTPMKR?	2-86
OUTPMSTA?	2-87
OUTPMTRC?	2-87
OUTPMTRCP?□<numeric>	2-88
OUTPMWID?	2-88
OUTPRAW{1-4}?	2-89
OUTPRESF?	2-89
OUTPRESO?	2-89
OUTPRESR?	2-89
OUTPSMKR{1-7}?	2-89
OUTPSWPRM?	2-90
OUTPSWPRMP?□<numeric>	2-90
OUTPXFIL?	2-90
PARS□{OFF ON 0 1}	2-91
PEAK?	2-91
PEAKCENT	2-91
PHAO□<numeric>[DEG]	2-92
PHAU {RAD DEG}	2-92
PKDLTX□<numeric>[HZ KHZ MAHZ GHZ DBM]	2-92
PKDLTY□<numeric>	2-93
PKPOL□{POS NEG}	2-93
PKTHREL□{OFF ON 0 1}	2-94
PKTHVAL□<value>	2-94
PLOC□{ALL DGRAT DONLY}	2-95
PLOS□{FAST SLOW}	2-96
PLOT	2-96
POIN□<numeric>	2-96
POLE?□<numeric>	2-97
POREL□{OFF ON 0 1}	2-97
PORT1□<numeric>[S MS US NS PS]	2-97
PORT2□<numeric>[S MS US NS PS]	2-98
PORTA□<numeric>[S MS US NS PS]	2-98
PORTB□<numeric>[S MS US NS PS]	2-98
PORTR□<numeric>[S MS US NS PS]	2-99
PORTZ□<numeric>	2-99
POWE□<numeric>[DBM]	2-99
PREP	2-100
PRES	2-100
PRIC	2-100
PRICFIXE	2-101
PRICVARI	2-101
PRINALL	2-101
PRIS	2-102
PRSMKRS	2-102
PSOFT□{OFF ON 0 1}	2-102
PURG□<string>	2-103
QUAD□{LEFU LEFL RIGU RIGL FULP}	2-103
RAID	2-104
RAISOL	2-104

RAIRESP	2-104
RECC	2-104
RECD \sqcup <i><string></i>	2-105
REFD	2-105
REFL	2-105
REFP \sqcup <i><numeric></i>	2-105
REFV \sqcup <i><numeric></i>	2-106
REFX \sqcup <i><numeric></i>	2-106
REFY \sqcup <i><numeric></i>	2-107
REPTSMP \sqcup {OFF ON 0 1}	2-107
RESAVD \sqcup <i><string></i>	2-108
RESC	2-108
RESCOM	2-108
RESD	2-109
RESPDONE	2-109
REST	2-109
REVI	2-109
REVM	2-109
REVT	2-109
RFO \sqcup {OFF ON 0 1}	2-110
RPLENV?	2-110
RPLHEI?	2-110
RPLLHEI?	2-110
RPLMEA?	2-111
RPLPP?	2-111
RPLRHEI?	2-111
RPLVAL?	2-111
RSCO	2-111
SA	2-112
SADD	2-112
SAUNIT \sqcup {DBM DBV DBUV W V}	2-112
SAV1	2-113
SAV2	2-113
SAVC	2-113
SAVCAL \sqcup {OFF ON 0 1}	2-114
SAVCOM	2-114
SAVDASC \sqcup <i><string></i>	2-114
SAVDAT \sqcup {OFF ON 0 1}	2-115
SAVDDAT \sqcup <i><string></i>	2-115
SAVDGRA \sqcup <i><string></i>	2-115
SAVDSTA \sqcup <i><string></i>	2-116
SAVDTRC \sqcup {OFF ON 0 1}	2-116
SAVEUSEK	2-117
SAVIMP	2-117
SAVMEM \sqcup {OFF ON 0 1}	2-117
SAVMTRC \sqcup {OFF ON 0 1}	2-117
SAVRAW \sqcup {OFF ON 0 1}	2-118
SAVUCOMK	2-118
SAVUFIXT	2-118
SCACL \sqcup {OFF ON 0 1}	2-118
SCAF \sqcup {DATA MEMO}	2-119
SCAL \sqcup <i><numeric></i>	2-119
SCAP \sqcup {FULL UGRT LGRT}	2-119
SCRN \sqcup {OFF ON 0 1}	2-120
SDEL	2-120

SDON	2-120
SEAL	2-120
SEAM␣{PEAK MAX MIN TARG PKSA PKSR PKSL OFF}	2-121
SEANPK	2-121
SEANPKL	2-122
SEANPKR	2-122
SEAR	2-122
SEARSTR	2-122
SEARSTRL	2-122
SEARSTRR	2-123
SEATARG␣<numeric>[DB DEG S OHM]	2-123
SEDI␣<numeric>	2-123
SETCDATE␣<numeric (year)>,<numeric (month)>,<numeric (day)>	2-124
SETCTIME␣<numeric (hour)>,<numeric (minute)>,<numeric (second)>	2-124
SETZ␣<numeric>[OHM KOHM MAOHM]	2-124
SGTRKL␣{OFF ON 0 1}	2-125
SIMFCHAR	2-125
SING	2-125
SLOP␣{OFF ON 0 1}	2-126
SLOPE␣<numeric>	2-126
SMKR{1-7}␣{OFF ON 0 1}	2-126
SMKRAUV{1-7}?	2-127
SMKRP{1-7}␣<numeric>	2-128
SMKRPRM{1-7}␣<numeric>[HZ KHZ MAHZ GHZ DBM]	2-128
SMKRVAL{1-7}?	2-129
SPAN␣<numeric>[HZ KHZ MAHZ GHZ DBM]	2-129
SPECFWD{M T}␣<numeric 1>[,<numeric 2>[,... [<numeric 7>]	2-130
SPECIMP{A B C}␣<numeric 1>[,<numeric 2>[,... [<numeric 7>]	2-130
SPECRES{I P}␣<numeric 1>[,<numeric 2>[,... [<numeric 7>]	2-131
SPECREV{M T}␣<numeric 1>[,<numeric 2>[,... [<numeric 7>]	2-131
SPECS1{A B C}␣<numeric 1>[,<numeric 2>[,... [<numeric 7>]	2-131
SPECS2{A B C}␣<numeric 1>[,<numeric 2>[,... [<numeric 7>]	2-132
SPLD␣{OFF ON 0 1}	2-132
SQUI	2-132
STAN{A-G}	2-133
STAR␣<numeric>[HZ KHZ MAHZ GHZ DBM]	2-133
STDD	2-133
STDT␣{OPEN SHOR LOAD DELA ARBI}	2-134
STOD{DISK MEMO}	2-134
STOP␣<numeric>[HZ KHZ MAHZ GHZ DBM]	2-134
SVCO	2-135
SWET␣<numeric>[S MS]	2-135
SWETAUTO␣{OFF ON 0 1}	2-135
SWPT␣{LINF LOGF LIST POWE}	2-135
TARL?	2-136
TARR?	2-136
TERI␣<numeric>[OHM KOHM]	2-136
TESS?	2-137
THRR␣<numeric>	2-137
TINT␣<numeric>	2-137
TITL␣<string>	2-138
TOPV␣<numeric>	2-138
TRACK␣{OFF ON 0 1}	2-138
TRAD	2-139
TRAN	2-139

TRGEVEL{SWE POIN}	2-139
TRGP{POS NEG}	2-140
TRGS{INT EXT BUS VID MAN GAT}	2-140
VBW<numeric>[HZ KHZ MAHZ]	2-141
VBWT{LIN LOG}	2-141
VELOFACT<numeric>	2-141
VIDLVL<numeric>	2-142
WIDSIN	2-142
WIDSOUT	2-142
WIDT{OFF ON 0 1}	2-142
WIDV<numeric>[DB DEG S OHM]	2-143
WIDVTYPE{DIVS2 MULS2 DIV2 FIXed}	2-143
ZA	2-143
ZMAPER<numeric>	2-144
Common Commands	2-145
*CLS	2-145
*ESE<numeric>	2-145
*ESR?	2-145
*IDN?	2-145
*OPC	2-146
*OPT?	2-146
*PCB<numeric>	2-146
*RST	2-147
*SRE<numeric>	2-147
*STB?	2-147
*TRG	2-147
*TST?	2-148
*WAI	2-148
SCPI Commands With No Equivalent Simple Command	2-149
:CALCulate:MATH1[:EXPReSSion]:CATALog?	2-149
:CALCulate:MATH2[:EXPReSSion]:CATALog?	2-149
:CALCulate:PATH?	2-149
:PROGram:CATALog?	2-150
:PROGram[:SELEcted]:DEFine<block>	2-150
:PROGram[:SELEcted]:DELete[:SELEcted]	2-151
:PROGram[:SELEcted]:DELete:ALL	2-151
:PROGram[:SELEcted]:EXECute<string>	2-151
:PROGram[:SELEcted]:MALLocate{<numeric> DEFault}	2-151
:PROGram[:SELEcted]:NAME<string>	2-151
:PROGram[:SELEcted]:NUMBer<string>,<numeric 1>[,<numeric 2> [, ... [,<numeric n>]	2-152
:PROGram[:SELEcted]:STATe{RUN PAUSE STOP CONTInue}	2-152
:PROGram[:SELEcted]:STRing<string (varname)>,<string (value 1)>[,<string (value 2)> [, ... [,<string (value n)>]	2-153
:PROGram[:SELEcted]:WAIT	2-153
:PROGram:EXPLicit:DEFine"PROG",<block>	2-154
:PROGram:EXPLicit:DELete"PROG"	2-154
:PROGram:EXPLicit:EXECute"PROG",<string>	2-154
:PROGram:EXPLicit:MALLocate"PROG",{<numeric> DEFault}	2-154
:PROGram:EXPLicit:NAME"PROG",<string>	2-154
:PROGram:EXPLicit:NUMBer"PROG",<varname>,<numeric 1>[,<numeric 2> [, ... [,<numeric n>] ...]]	2-154
:PROGram:EXPLicit:STATe"PROG",{RUN PAUSE STOP CONTInue}	2-154
:PROGram:EXPLicit:STRing"PROG",<varname>,<string 1>[,<string 2> [, ... [,<string n>] ...]]	2-154

:PROG:EXPLICIT:WAIT "PROG"	2-154
:STATUS:PRESET	2-155
:STATUS:QUESTIONABLE:CONDITION?	2-155
:STATUS:QUESTIONABLE:ENABLE<numeric>	2-155
:STATUS:QUESTIONABLE[:EVENT]?	2-155
:SYSTEM:VERSION?	2-155
Service Related Commands	2-156
:DIAG:REFERENCE:STATE?	2-156
:DIAG:FREVISION?	2-156
:DIAG:INIT:RESULT?	2-157
:DIAG:SERVICE:BUS:AZERO<{OFF ON 0 1}>	2-157
:DIAG:SERVICE:BUS:DC<numeric>	2-157
:DIAG:SERVICE:BUS:FREQ<numeric>	2-158
:DIAG:SERVICE:BUS:STATE<{OFF ON 0 1}>	2-158
:DIAG:SERVICE:BUS:WAIT<numeric>	2-158
:DIAG:SERVICE:CCONSTANT:FRESPONSE<{OFF ON 0 1}>	2-159
:DIAG:SERVICE:CCONSTANT:IFGAIN<{OFF ON 0 1}>	2-159
:DIAG:SERVICE:CCONSTANT:SOURCE<{OFF ON 0 1}>	2-159
:DIAG:SERVICE:CCONSTANT:XTAL<{OFF ON 0 1}>	2-160
:DIAG:SERVICE:IF:ADMX:MODEL<{AUTO ALTERNATE DEG0 DEG90}>	2-160
:DIAG:SERVICE:IF:BPFILTER:MODEL<{AUTO BW3M BW1M XTAL}>	2-161
:DIAG:SERVICE:IF:GAIN:MODEL<{AUTO MANUAL}>	2-161
:DIAG:SERVICE:IF:GAIN:W<{AUTO DB0 DB10}>	2-161
:DIAG:SERVICE:IF:GAIN:X<{AUTO DB0 DB18}>	2-162
:DIAG:SERVICE:IF:GAIN:Y<{AUTO DB0 DB6 DB12 DB18}>	2-162
:DIAG:SERVICE:IF:GAIN:Z<{AUTO DB0 DB2 DB4 DB18}>	2-163
:DIAG:SERVICE:IF:LPFILTER:MODEL<{AUTO BW5K BW15K BW50K BW150K THROUGH}>	2-163
:DIAG:SERVICE:IF:RANGE:FL<{HIGH LOW}>	2-164
:DIAG:SERVICE:IF:RANGE:MODEL<{AUTO MANUAL}>	2-164
:DIAG:SERVICE:IF:RANGE:RL<{HIGH LOW}>	2-164
:DIAG:SERVICE:IF:SHBW:MODEL<{AUTO NARROW MIDDLE WIDE}>	2-164
:DIAG:SERVICE:IF:TLOCAL:MODEL<{AUTO AC DC}>	2-165
:DIAG:SERVICE:MODEL<{ON 1}>	2-165
:DIAG:SERVICE:SOURCE:ALCLOOP<{OPEN CLOSE}>	2-165
:DIAG:SERVICE:SOURCE:ATTENUATOR<{AUTO DB0 DB10 DB20 DB30 DB40 DB50 DB60}>	2-166
:DIAG:SERVICE:SOURCE:GAIN:DAC:MODEL<{AUTO MANUAL}>	2-166
:DIAG:SERVICE:SOURCE:GAIN:DAC:VALUE<numeric>	2-167
:DIAG:SERVICE:SOURCE:LEVEL:DAC:MODEL<{AUTO MANUAL}>	2-167
:DIAG:SERVICE:SOURCE:LEVEL:DAC:VALUE<numeric>	2-167
:DIAG:SERVICE:SOURCE:MODEL<{AUTO MANUAL}>	2-168
:DIAG:SERVICE:SYNTHESIZER:FLOCAL:MODEL<{AUTO SINGLE TRIPLE}>	2-168
:DIAG:SERVICE:SYNTHESIZER:FN:MODEL<{AUTO NARROW WIDE}>	2-168
:DIAG:SERVICE:SYNTHESIZER:FREQUENCY:OFFSET<numeric>	2-169
:DIAG:SERVICE:SYNTHESIZER:STEP:DAC:MODEL<{AUTO MANUAL}>	2-169
:DIAG:SERVICE:SYNTHESIZER:STEP:DAC:VALUE<numeric>	2-169
:DIAG:SERVICE:SYNTHESIZER:STEP:LOOP<{OPEN CLOSE}>	2-170
:DIAG:SERVICE:SYNTHESIZER:STEP:MODEL<{AUTO MANUAL}>	2-170
:DIAG:SERVICE:SYNTHESIZER:STEP:OUTPUT<{OFF ON 0 1}>	2-170
:DIAG:SERVICE:SYNTHESIZER:STEP:POLARITY<{AUTO POSITIVE NEGATIVE}>	2-170
:DIAG:TEST<numeric>	2-171
:DIAG:TEST:CONTINUE	2-171
:DIAG:TEST:EXECUTE	2-171
:DIAG:TEST:RESULT?<numeric>	2-172

A. Manual Changes	
Introduction	A-1
Manual Changes	A-1
Change 1	A-2
Change 2	A-3
Serial Number	A-3
B. Command Summary	
C. SCPI Commands Summary	
D. Status Reporting	
OSPT, OSNT	D-5
OSPT (Operation Status Positive Transition Filter)	D-5
OSNT (Operation Status Negative Transition Filter)	D-5
E. Trigger System	
Trigger System	E-1
Analyzer Trigger System Configuration	E-1
Idle State	E-2
Initiate State	E-2
Trigger Event Detection State	E-2
Sequence Operation State	E-2
F. Calibration Types and Standard Classes, and Calibration Arrays	
G. Key Codes	
H. Data Format and Data Levels	
Data Format	H-1
Data Levels	H-2
Marker Readout	H-3
I. Waveform Analysis Commands	
Conventions and Definitions	I-2
Waveform Analysis Setup Commands	I-3
ANAOCH1	I-3
ANAOCH2	I-3
ANARANG	I-4
ANARFULL	I-4
ANAODATA	I-5
ANAOMEMO	I-5
THRR	I-6
Maximum/Minimum/Mean Value Search Commands	I-7
OUTPMAX?	I-7
OUTPMIN?	I-7
OUTPMINMAX?	I-8
OUTPMEAN?	I-8
PEAK?	I-9
NEXPK?	I-10
NUMLMAX?	I-11
NUMLMIN?	I-11
LMAX?	I-12
LMIN?	I-12
TARR?	I-13

TARL?	I-14
Ripple Analysis Commands	I-15
RPLPP?	I-15
RPLHEI?	I-17
RPLRHEI?	I-18
RPLLHEI?	I-19
RPLENV?	I-20
RPLMEA?	I-21
RPLVAL?	I-22
POLE?	I-23
Filter and Resonator Analysis Commands	I-25
OUTPFILT?	I-26
OUTPXFIL?	I-28
OUTPCFIL?	I-31
OUTPRESO?	I-34
OUTPRESR?	I-36
OUTPRESF?	I-38
OUTPCERR?	I-40
Equivalent circuit analysis commands	I-42
EQUCPARA?	I-43
EQUCPARS?	I-46
EQUC0? <i>value</i>	I-47
EQUCPARS4?	I-49

Messages

Index

Figures

I-1. Proper Use of the Colon and Semicolon	I-4
A-1. Serial Number Plate	A-3
D-1. Status Reporting Structure	D-1
D-2. Example of Reading Status Byte (1)	D-2
D-3. Example of Reading Status Byte (2)	D-2
D-4. Example of Generating a Service Request (SRQ)	D-5
E-1. Trigger System Configuration	E-1
E-2. Inside an Trigger Event Detection State	E-2
G-1. Key Codes	G-1
H-1. Form 2 Data Transfer Format	H-1
H-2. Form 3 Data Transfer Format	H-1
I-1. THRR	I-6
I-2. RPLPP?	I-15
I-3. RPLHEI?	I-17
I-4. RPLRHEI?	I-18
I-5. RPLLHEI?	I-19
I-6. RPLENV?	I-20
I-7. RPLMEA?	I-21
I-8. RPLVAL?	I-22
I-9. POLE?	I-23
I-10. OUTPFILT?	I-26
I-11. OUTPXFIL?	I-29
I-12. OUTPCFIL?	I-32
I-13. OUTPRESO?	I-34
I-14. OUTPRESR?	I-36
I-15. OUTPRESF?	I-38
I-16. OUTPCERR?	I-40
I-17. Six-Device Equivalent Circuit of Crystal Resonator	I-43
I-18. Four-Device Equivalent Circuit of Crystal Resonator	I-49
I-19. Admittance Characteristic Circle Diagram	I-50

Tables

A-1. Manual Changes by Serial Number	A-1
A-2. Manual Changes by Firmware Version	A-1
A-3. Additional Command of Firmware Revision 2.00	A-2
A-4. Additional Command of Firmware Revision 3.00	A-3
D-1. Status Bit Definitions of the Status Byte (STB)	D-2
D-2. Status Bit Definitions of the Standard Event Status Register (ESR)	D-3
D-3. Status Bit Definitions of the Event Status Register B (ESB)	D-4
D-4. Status Bit Definitions of the Operation Status Register (OSR)	D-4
F-1. Calibration Types and Standard Classes	F-1
F-2. Calibration Array	F-2
H-1. Marker Readout	H-3

Introduction

This manual provides a reference for the Hewlett-Packard Interface Bus (HP-IB) commands used to control the HP 4396A Network/Spectrum Analyzer (analyzer). These commands are implemented using an external controller or the HP Instrument BASIC (option 1C2).

The following is a brief description of each chapter and appendix.

Chapter 2 explains all the HP-IB commands.

Appendix A contains the information required to adapt this manual to earlier versions or configurations of the analyzer than the current printing date of this manual.

Appendix B lists all the HP-IB commands sorted by the function (key label).

Appendix C lists all the HP-IB commands in alphabetical order for the Standard Commands for Programmable Instruments (SCPI) commands.

Appendix D provides information about the status reporting structure for service request functions.

Appendix E provides information about the trigger system, which corresponds to the SCPI standard.

Appendix F describes the calibration types and the standard classes, and the calibration coefficients.

Appendix G provides the front-panel key codes for the KEY HP-IB commands.

Appendix H provides information about data formats and data levels.

Appendix I provides detail information about the waveform analysis commands.

Error Messages lists all error messages with an explanation for each error.

See the *HP-IB Programming Guide* for introduction to using the analyzer's HP-IB commands. See the *Using HP Instrument BASIC with the HP 4396A* for a description of how the HP Instrument BASIC works with the analyzer.

Note



You should become familiar with the operation of the analyzer before you attempt to control it using HP-IB commands. See the following documents which are better suited to this task.

For more information concerning the operation of the analyzer, see the following:

User's Guide

Task Reference

Function Reference

Option 010 Operating Handbook for impedance measurement mode.

Note

This manual is not intended to teach the BASIC programming language or the Standard Commands for Programmable Instruments (SCPI) commands. It also does not discuss HP-IB theory. See the following documents that are better suited to these tasks.

For more information concerning BASIC, see the manual set for the BASIC version being used:

BASIC Programming Techniques
BASIC Language Reference

For more information concerning SCPI, see the following:

Beginner's Guide to SCPI

For more information concerning HP-IB operation, see the following:

BASIC Interfacing Techniques
Tutorial Description of the Hewlett-Packard Interface Bus
Condensed Description of the Hewlett-Packard Interface Bus

HP-IB Commands

Most of the analyzer's functions have two corresponding HP-IB commands. One is unique to the analyzer (called a **Simple command**) and another corresponds to the Standard Commands for Programmable Instruments (called a **SCPI command**). You can use both commands in one program.

- For example, the command to select the analyzer type is as follows:

```
Simple command:  NA
SCPI command:   :INSTRument:TYPE NA
```

The analyzer also has other commands (called **Common command**) that are not measurement related. These include commands for functions such as status register control or synchronization.

- For example, the command to clear status registers is as follows:

```
*CLS
```

Simple Commands

All the analyzer's front-panel keys have corresponding HP-IB commands. The names of the simple commands are derived from their front panel key titles (where possible). Commands that have no equivalent front-panel key use a similar convention based on the common name of the function.

SCPI Commands

SCPI is the instrument command language for controlling instrument that goes beyond IEEE 488.2 standard to address a wide variety of instrument functions in a standard manner.

Common Commands

All common commands begin with an asterisk (*). Common commands are defined by IEEE 488.2.

SCPI Subsystem Commands

Subsystem commands include all measurement functions and some general purpose functions. Each subsystem is a set of commands that roughly corresponds to a functional block inside the instrument.

Subsystem commands have a hierarchical structure, called a **command tree**, that consists of several key words separated by a colon between each word.

Subsystem Command Tree

The top of the subsystem command tree is called the **root command**, or simply the **root**. To reach the low-level commands, you must specify a particular **path** (like a DOS file directory path). After Power ON or after presetting, the current path is set to the root. The path settings are changed as follows:

- Program Message Terminator** A program message terminator, such as <new line> character, sets the current path to the root.
- Colon (:)** When a colon is placed between two command mnemonics, the colon moves the current path down one level on the command tree. When the colon is the first character of a command, it specifies that the following command mnemonic is a root-level command.
- Semicolon (;)** A semicolon separates two commands in the same message without changing the current path.

Figure 1-1 shows examples of how to use the colon and semicolon to navigate efficiently through the command tree.

Common commands, such as *RST, are not part of any subsystem. The analyzer interprets them in the same way, regardless of the current path setting.

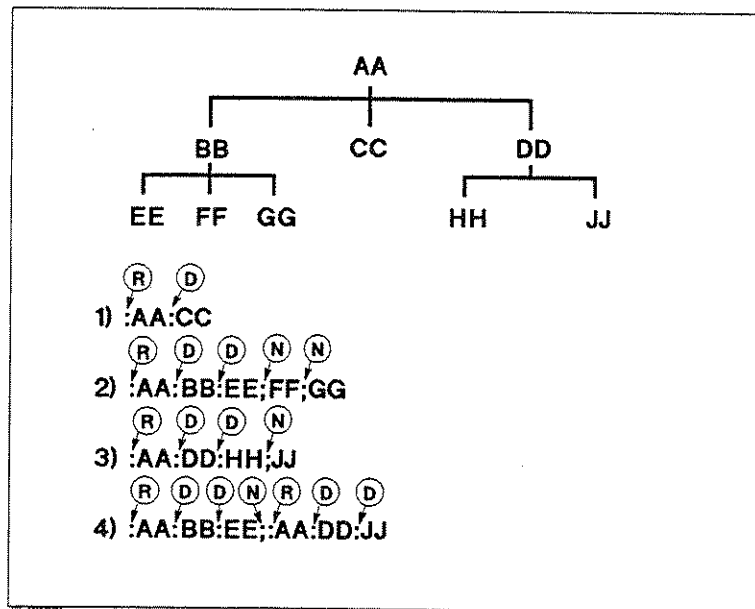

Figure 1-1. Proper Use of the Colon and Semicolon

- Ⓡ sets the current path to the root.
- Ⓧ moves the current path down one level.
- Ⓝ does not change the current path.

Command Abbreviations

Many commands have a long and a short form. In this manual, all commands are spelled out in the long form. The short form is obtained by deleting the lower case letters.

For example, the short form of :INITiate is :INIT and the long form of it is :INITIATE. (SCPI does *not* accept anything in between, such as :INITIA.)

Program Message Syntax

This section provides the construction of program messages. A program message is the message that you send from a computer to an instrument. Program messages consist of commands combined with appropriate punctuation and program message terminators.

Case

Letter cases (upper and lower) are ignored.

Program Message Terminator

A program message must end with one of the three **program message terminators**, <new line>, <^END>, or <new line><^END>. <^END> means that End Of Identify (EOI) is asserted on the HP-IB interface at the same time the preceding data byte is sent. For example, the HP BASIC OUTPUT statement is automatically sent after last data byte. If you are using a PC, you can usually configure your system to send whatever terminator you specify.

Multiple Messages

To send more than one command in the same message, you must separate them with a semicolon:

```
NA;CHAN1
```

Query and Response Message Syntax

All commands can be queried except the commands described as “no query” in the command reference. To send a query message, add ? after the last command mnemonic.

```
NA?
```

A response message may contain both commas and semicolons as separators. When a single query command returns multiple values, a comma is used to separate each data item. When multiple queries are sent in the same message, the group of data items corresponding to each query are separated by a semicolon. For example, the fictitious query :QUERY1?;QUERY2? might return a response message of:

```
<data1>,<data1>;<data2>,<data2>
```

After the message, <new line><^END> is always sent as a response message terminator.

Parameters

There must be a <space> between the last command mnemonic and the first parameter in a subsystem command.

CENT␣*parameter*

␣ means a space (ASCII character (decimal 32)).

If you send more than one parameter with a single command, each parameter must be separated by a comma.

Parameter Types

The analyzer accepts commands and parameters in various formats and responds to a particular query in a predefined and fixed format. Each command reference contains information about the parameter types available for the individual commands.

■ <*numeric*> represents numeric parameters as follows:

100	no decimal point required
100.	fractional digits optional
-1.23, +235	leading signs allowed
4.56e␣3	space allowed after e in exponentials
-7.89E-01	use either E or e in exponentials
.5	digits left of decimal point optional

The analyzer setting programmed with a numeric parameter can assume a finite number of values, so the analyzer automatically rounds off the parameter. For example, the analyzer has a programmable input attenuator value. If you specified 50.1, it would be rounded off to 50.

Query response of <*numeric_value*> is always a numeric value in <NR1> (integer) or <NR3> (floating point) format.

□ Suffix

When a command has a specified suffix, the suffix multiplier and suffix units can be used with parameters as follows. (The suffix multiplier must be used with the suffix unit.):

Frequency:	HZ (Hz; default), KHZ (kHz), MAHZ or MHZ (MHz), GHZ (GHz)
Power:	DBM (dBm; default)
Attenuator:	DB (dB; default)
Time:	S (second; default), MS (ms), US (μ s), NS (ns), PS (ps), FS (fs)
Scale:	DB (dB), DEG ($^{\circ}$), S (second), DBM (dBm), DBV (dBV), DBUV ($\text{dB}\mu\text{V}$), W (watt), V (Volt), OHM (Ω), SIE (siemens)
Phase:	DEG ($^{\circ}$; default)
Capacitance:	F (farad; default)
Percent:	PCT (%; default)
Impedance:	OHM (Ω ; default), KOHM (k Ω)
Loss:	DB (dB; default)

The suffix is optional and can be omitted.

■ <*string*> is a string parameter that contains ASCII characters. A string must begin with a single quote (ASCII 39 decimal) or a double quote (ASCII 34 decimal) and end with the same corresponding character, a single or double quote. The quote to mark the beginning and end of the string is called the delimiter. You can include the delimiter as part of the string by typing it twice without any characters in between.

Example of *<string>* TXT,

```
OUTPUT @Meter;"ASCE 'TXT'"      using single quote  
OUTPUT @Meter;"ASCE ""TXT""    using double quote
```

The query response is the string between double quote delimiters.

- *<block>* is typically used to transfer large quantities of related data. *<block>* can be sent as the definite length blocks.

General form of block parameters:

```
#<num_digits><num_bytes><data bytes>
```

The single decimal digit *<num_digits>* specifies how many digits are contained in *<num_bytes>*. The decimal number *<num_bytes>* specifies how many data bytes will follow in *<data bytes>*.

Example of *<block>* ABC+XYZ,

```
OUTPUT @Meter;"#17ABC+XYZ"
```

(1 means one digit follows, 7 means seven bytes follow.)

Commands Reference

This chapter provides a reference for the HP-IB commands of the analyzer. Use this information as a reference to the syntax requirements and general function of the individual commands.

This chapter is organized as follows:

- Simple Commands
- Common Commands
- SCPI Commands With No Equivalent Simple Command
- Service Related Commands

Within each group the commands are listed in alphabetical order. See Appendix B for a functional list of the commands. See Appendix C for a list of the SCPI commands in alphabetical order.

See the *Function Reference* for the details of each function. See *HP-IB Programming Guide* for an introduction to using the analyzer's HP-IB Commands.

The following conventions and definitions are used to describe the commands.

① → **AVER**␣{OFF|ON|0|1}

② → Turns the averaging function ON or OFF for the active channel. (**AVERAGING on off** under **Bw/Avg**)

③ →

Parameter	Description
OFF or 0	Averaging function OFF
ON or 1	Averaging function ON

④ → ■ Query Response

{0|1} <new line> <END>

⑤ → ■ Equivalent SCPI Command

:SENSe:AVERAge[:STATe] {OFF|ON|0|1}

⑥ → ■ Example

OUTPUT 717;"AVER ON"

OUTPUT 717;"AVER?"

ENTER 717;A

OUTPUT 717;":SENS:AVER ON"

OUTPUT 717;":SENS:AVER?"

ENTER 717;A

①	<p>Command name and required parameter.</p> <p>Upper case bold characters represent the command that must appear exactly as shown with no embedded spaces. Upper and lower case characters are equivalent.</p> <p>A constant or a pre-assigned simple or complex numeric or string variable transferred to the analyzer. There must be a space between it and the code. (␣ indicates a space.)</p> <p>Characters enclosed in the { } brackets are qualifiers attached to the root mnemonic. There can be no spaces or symbols between the root mnemonic and its appendage. For example, {OFF ON 0 1} means OFF, ON, 0, or 1, and {1-4} means 1, 2, 3, or 4.</p>
②	<p>Description.</p> <p>Key or softkey that has the same function is shown in the brackets. The brackets may include more additional information.</p>
③	<p>Parameter description of the Simple command and SCPI command.</p>
④	<p>Query response of the Simple command and SCPI command.</p> <p>If the query response of the SCPI command differs from the response of the Simple command, the query response of the SCPI command is described in "Equivalent SCPI Command."</p>
⑤	<p>Equivalent SCPI command to the Simple command.</p> <p>See "SCPI Commands" in Chapter 1 for more information about the SCPI command. Square brackets indicate that the enclosed information is optional.</p>
⑥	<p>Example of the usage of the Simple command and SCPI command (including their query forms).</p>

Simple Commands

ADDRCONT□<numeric>

Sets the HP-IB address the analyzer will use to communicate with the external controller.
(ADDRESS: CONTROLLER under (Local))

Parameter	Range	Unit
<numeric>	0 to 30	

- Query Response

{numeric} <new line><END>

- Equivalent SCPI Command

:SYSTEM:COMMunicate:GPIB2:ADDRESS□<numeric>

ADDRPLOT□<numeric>

Sets the HP-IB address the analyzer will use to communicate with the plotter.
(ADDRESS: PLOTTER under (Local))

Parameter	Range	Unit
<numeric>	0 to 30	

- Query Response

{numeric} <new line><END>

- Equivalent SCPI Command

:SYSTEM:COMMunicate:GPIB:HCOPY1:ADDRESS□<numeric>

ADDRPRIN□<numeric>

Sets the HP-IB address the analyzer will use to communicate with the printer.
(ADDRESS: PRINTER under (Local))

Parameter	Range	Unit
<numeric>	0 to 30	

- Query Response

{numeric} <new line><END>

- Equivalent SCPI Command

:SYSTEM:COMMunicate:GPIB:HCOPY2:ADDRESS□<numeric>

ANAOCH1

Selects channel 1 for waveform analysis. For details, see “ANAOCH1” in Appendix I. (Instrument BASIC EXECUTE executable; No equivalent SCPI command; Network and spectrum analyzer only)

■ Query Response

Parameter	Description
OFF or 0	Analysis for channel 1 is off.
ON or 1	Analysis for channel 1 is on.

ANAOCH2

Selects channel 2 for waveform analysis. For details, see “ANAOCH2” in Appendix I. (Instrument BASIC EXECUTE executable; No equivalent SCPI command; Network and spectrum analyzer only)

■ Query Response

Parameter	Description
OFF or 0	Analysis for channel 1 is off.
ON or 1	Analysis for channel 1 is on.

ANAODATA

Selects a data trace for waveform analysis. For details, refer to “ANAODATA” in Appendix I. (Instrument BASIC EXECUTE executable; No equivalent SCPI command; Network and spectrum analyzer only)

■ Query Response

Parameter	Description
OFF or 0	Analysis for data trace is off.
ON or 1	Analysis for data trace is on.

ANAOMEMO

Selects a memory trace for waveform analysis. For details, refer to “ANAOMEMO” in Appendix I. (Instrument BASIC EXECUTE executable; No equivalent SCPI command; Network and spectrum analyzer only)

■ Query Response

Parameter	Description
OFF or 0	Analysis for memory trace is off.
ON or 1	Analysis for memory trace is on.

ANARANG┘<numeric1>,<numeric2>

Sets the waveform analysis stimulus range by entering the START and STOP values. For details, see "ANARANG" in Appendix I. (Instrument BASIC EXECUTE executable; No equivalent SCPI command; Network and spectrum analyzer only)

Parameter	Range	Description (Unit)
<numeric1>	100000 (= 100 k) to 1.82×10^9 (= 1.82 G) (Network and Impedance analyzer) 0 to 1.82×10^9 (= 1.82 G) (Spectrum analyzer) -70 to 20	Start Frequency (Hz) Hz (frequency) Start Power (dBm)
<numeric2>	100000 (= 100 k) to 1.82×10^9 (= 1.82 G) (Network and Impedance analyzer) 0 to 1.82×10^9 (= 1.82 G) (Spectrum analyzer) -70 to 20	Stop Frequency (Hz) Hz (frequency) Stop Power (dBm)

- Query Response

```
{numeric1},{numeric2}<new line><END>
```

ANARFULL

Sets the analysis range equal to the full stimulus range. For details, see "ANARFULL" in Appendix I. (Instrument BASIC EXECUTE executable; No equivalent SCPI command; Network and spectrum analyzer only)

ASCE┘<string>

Changes the extension of an ASCII data file for DOS format. The extension is automatically attached to the file name when an ASCII data file is saved. The factory setting is ".TXT". A modified extension is kept in SRAM even if power is OFF. (ASCII DATA [.TXT] under **Save**)

Parameter	Description
<string>	Up to 3 characters.

- Query Response

```
{string} <new line><END>
```

- Equivalent SCPI Command

```
:MMEMory:FNAME:EXTension2┘<string>
```

- Example

```
OUTPUT 717;"ASCE ""TXT"""
```

ATT<numeric>[DB]

Changes the input attenuation when the S input is selected. Because the attenuators at the R, A, and B inputs are fixed, if either R, A, or B is selected, you can enter the value but not change. (Spectrum analyzer only) (ATTEN under [Scale Ref](#))

Parameter	Range	Unit
<numeric>	0, 10, 20, 30, 40, 50, 60	dB

■ Query Response

{numeric} <new line><END>

■ Equivalent SCPI Command

:SENSe:POWer:AC:ATTenuation:AUTO{OFF|0}
:SENSe:POWer:AC:ATTenuation<numeric>

■ Example

```
OUTPUT 717;"ATT 10DB"  
OUTPUT 717;":SENS:POW:AC:ATT:AUTO OFF"  
OUTPUT 717;":SENS:POW:AC:ATT 10"
```

ATTAUTO{OFF|ON|0|1}

Sets the automatic and manual spectrum analyzer input attenuator of the S input. (Spectrum analyzer only) (ATTEN AUTO man under [Scale Ref](#))

Parameter	Description
OFF or 0	Manual attenuator
ON or 1	Automatic attenuator

■ Query Response

{0|1} <new line><END>

■ Equivalent SCPI Command

:SENSe:POWer:AC:ATTenuation:AUTO{OFF|ON|0|1}

ATTP1<numeric>[DB]

Controls the attenuation at port 1 of an S-parameter Test Set connected to the analyzer. (Network analyzer only) (ATTENUATOR PORT 1 under [Source](#))

Parameter	Range	Unit
<numeric>	0, 10, 20, 30, 40, 50, 60, 70	dB

■ Query Response

{numeric} <new line><END>

■ Equivalent SCPI Command

:OUTPut:ATTenuation1<numeric>

ATTP2┘<numeric>[DB]

Controls the attenuation at port 2 of an S-parameter Test Set connected to the analyzer. (Network analyzer only) (ATTENUATOR PORT 2 under Source)

Parameter	Range	Unit
<numeric>	0, 10, 20, 30, 40, 50, 60, 70	dB

- Query Response
 {numeric} <new line><END>
- Equivalent SCPI Command
 :OUTPut:ATTenuation2┘<numeric>

AUTO

Brings the trace data, defined by the SCAF command, in view on the display. (Network and impedance analyzer only) (AUTO SCALE under Scale Ref; No query)

- Equivalent SCPI Command
 :DISPlay[:WINDow]:TRACe{[1]|2}:Y[:SCALE]:AUTO┘ONCE
 (TRACe[1] for the data trace; TRACe2 for the memory trace.)

AVER┘{OFF|ON|0|1}

Turns the averaging function ON or OFF for the active channel. (AVERAGING ON off under Bw/Avg)

Parameter	Description
OFF or 0	Averaging function OFF
ON or 1	Averaging function ON

- Query Response
 {0|1} <new line><END>
- Equivalent SCPI Command
 :SENSe:AVERage[:STATe]┘{OFF|ON|0|1}

AVERFACT┘<numeric>

Makes the averaging factor for the active function. (AVERAGING FACTOR under Bw/Avg)

Parameter	Range	Unit
<numeric>	1 to 999	

- Query Response
 {numeric} <new line><END>
- Equivalent SCPI Command

AVERFACT□<numeric>

:SENSe:AVERAge:COUNt□<numeric>

AVERREST

Resets the sweep-to-sweep averaging and restarts the sweep count at 1 at the beginning of the next sweep. (AVERAGING RESTART under **Bw/Avg**; No query)

- Equivalent SCPI Command

:SENSe:AVERAge:CLEAr

BACI□<numeric>[PCT]

Sets the background intensity of the display as a percent of the white level. (BACKGROUND INTENSITY under **Display**)

Parameter	Range	Unit
<numeric>	0 to 100 (simple command)	%
<numeric>	0 to 1 (SCPI command)	

- Query Response

{numeric} <new line><END>

- Equivalent SCPI Command

:DISPlay:CONTRast□<numeric>

BEEPDONE□{OFF|ON|0|1}

Sets an annunciator that sounds to indicate completion of certain operations such as calibration or instrument state save. (BEEP DONE ON off under **System**)

Parameter	Description
OFF or 0	Operation completion beeper OFF
ON or 1	Operation completion beeper ON

- Query Response

{0|1} <new line><END>

- Equivalent SCPI Command

:SYSTem:BEEPer1:STATe□{OFF|ON|0|1}

BEEPFALL□{OFF|ON|0|1}

Turns the limit fail beeper ON or OFF. When the limit testing is ON and the fail beeper is ON, a beep is emitted each time a limit test is performed and a failure is detected.

(BEEP FAIL ON off under **System**)

Parameter	Description
OFF or 0	Limit fail beeper OFF
ON or 1	Limit fail beeper ON

BW \square *<numeric>* [HZ|KHZ|MAHZ]

■ Query Response

{0|1} <new line><END>

■ Equivalent SCPI Command

:CALCulate:LIMit:BEEPer[:STATe] \square {OFF|ON|0|1}

BEEPWARN \square {OFF|ON|0|1}

Sets the warning annunciator. When the annunciator is ON, it sounds a warning when a cautionary message is displayed. (BEEP WARN ON off under **System**)

Parameter	Description
OFF or 0	Warning beeper OFF
ON or 1	Warning beeper ON

■ Query Response

{0|1} <new line><END>

■ Equivalent SCPI Command

:SYSTem:BEEPer2:STATe \square {OFF|ON|0|1}

BOTV \square *<numeric>*

Defines the bottom border of the display and adjusts the scale value. (BOTTOM VALUE under **Scale Ref**; Impedance analyzer only)

Parameter	Range	Unit
<i><numeric></i>	-500×10^6 to 500×10^6	y-axis unit

■ Query Response

{*numeric*} <new line><END>

■ Equivalent SCPI Command

:DISPlay[:WINDow]:TRACe{1|2}:Y[:SCALE]:BOTTom \square *<numeric>*

BW \square *<numeric>* [HZ|KHZ|MAHZ]

Sets the bandwidth value for IF bandwidth reduction, or sets the IF bandwidth of the list sweep table. (Network analyzer and Impedance analyzer) (IF BW under **Bw/Avg**, or IF BW under **Sweep**)

Sets the bandwidth value for the resolution bandwidth reduction, or sets the resolution bandwidth of the list sweep table. (Spectrum analyzer) (RES BW under **Bw/Avg**, or RES BW under **Sweep**)

2: Commands Reference

BW \square *<numeric>* [HZ|KHZ|MAHZ]

Parameter	Range	Unit
<i><numeric></i>	10, 30, 100, 300, 1000 (= 1 k), 3000 (= 3 k), 10000 (= 10 k), 40000 (= 40 k) (network analyzer and impedance analyzer) 1, 3, 10, 30, 100, 300, 1000 (= 1 k), 3000 (= 3 k), 10000 (= 10 k), 30000 (= 30 k), 100000 (= 100 k), 300000 (= 300 k), 1000000 (= 1 M), 3000000 (= 3 M) (spectrum analyzer)	Hz

■ Query Response

{numeric} <new line><END>

■ Equivalent SCPI Command

Network and impedance analyzer :SENSe:BANDwidth[:RESolution] \square *<numeric>*Spectrum analyzer :SENSe:BANDwidth[:RESolution]:AUTO \square {OFF|0}
:SENSe:BANDwidth[:RESolution] \square *<numeric>*IF BW, RES BW under **Sweep** :SENSe:LIST:SEGment:BANDwidth \square *<numeric>***BWAUTO** \square {OFF|ON|0|1}

Sets either the automatic or manual resolution bandwidth ON. (Spectrum analyzer only)

(RES BW AUTO man under Bw/Avg)

Parameter	Description
OFF or 0	Manual resolution bandwidth.
ON or 1	Automatic resolution bandwidth.

■ Query Response

{0|1} <new line><END>

■ Equivalent SCPI Command

:SENSe:BANDwidth[:RESolution]:AUTO \square {OFF|ON|0|1}**BWSRAT** \square *<numeric>*

Sets the RBW/SPAN ratio that specifies the resolution bandwidth in the AUTO mode. (Spectrum analyzer only)

(RBW/SPAN RATIO under Bw/Avg)

Parameter	Range	Unit
<i><numeric></i>	0.01 to 10 (of SPAN)	%

■ Query Response

{numeric} <new line><END>

■ Equivalent SCPI Command

:SENSe:BANDwidth[:RESolution]:RATIO \square *<numeric>*

C0 \square *<numeric>*

Enters the C_0 term, which is the constant term of the capacitance model equation. (Network and impedance analyzer only) (C0 under **Cal**); No query)

Parameter	Range	Unit
<i><numeric></i>	0 to 1000 ($\times 10^{-15}$)	F

- Equivalent SCPI Command

```
:SENSe:CORRection:CKIT:STANdard:C0  $\square$  <numeric>
```

C1 \square *<numeric>*

Enters the C_1 term, which is the constant term of the capacitance model equation. (Network and impedance analyzer only) (C1 under **Cal**); No query)

Parameter	Range	Unit
<i><numeric></i>	0 to 1000 ($\times 10^{-27}$)	F/Hz

- Equivalent SCPI Command

```
:SENSe:CORRection:CKIT:STANdard:C1  $\square$  <numeric>
```

C2 \square *<numeric>*

Enters the C_2 term, which is the constant term of the capacitance model equation. (Network and impedance analyzer only) (C2 under **Cal**); No query)

Parameter	Range	Unit
<i><numeric></i>	0 to 1000 ($\times 10^{-36}$)	F/Hz ²

- Equivalent SCPI Command

```
:SENSe:CORRection:CKIT:STANdard:C2  $\square$  <numeric>
```

CALCASSI

Shows the tabular listing of the calibration kit class assignment. (CLASS ASSIGNMENT under **Copy**); No query)

- Equivalent SCPI Command

```
:DISPlay[:WINDow]:TEXT3:PAGE  $\square$  1
:DISPlay[:WINDow]:TEXT3:STATe  $\square$  {ON|1}
```

CALECPARA

Calculates and displays the equivalent circuit parameters. (CALCULATE EQV PARAMS under **Display**); No query; Impedance analyzer only)

■ Equivalent SCPI Command

```
:CALCulate:EVALuate:EPARameters
:DISPlay[:WINDow]:TEXT18:STATel{ON|1}
```

CALIl{NONE|RESP|RAI|S111|S221|FUL2|ONE2|IMP}

Selects the measurement calibration type. (Network analyzer and impedance analyzer only) (CALIBRATE:NONE, RESPONSE, RESPONSE & ISOL'N, S11 1-PORT, S22 1-PORT, FULL 2-PORT, ONE PATH 2-PORT under **Cal** of network analyzer mode or CALIBRATE MENU under **Cal** of impedance analyzer mode.)

Parameter	Description
NONE	No calibration
RESP	Response measurement calibration
RAI	Response and isolation measurement calibration
S111	1-Port measurement calibration at port 1
S221	1-Port measurement calibration at port 2
FUL2	Full 2-Port measurement calibration
ONE2	One-path 2-Port measurement calibration
IMP	Calibration of the impedance analyzer mode. (Impedance analyzer only)

■ Query Response

```
{NONE|RESP|RAI|S111|S221|FUL2|ONE2|IMP} <new line><END>
```

■ Equivalent SCPI Command

```
CALIlNONE :SENSe:CORRection:COLLect:METhodlNONE
CALIlRESP :SENSe:CORRection:COLLect:METhodlRESPonse
CALIlRAI :SENSe:CORRection:COLLect:METhodlRAIisol
CALIlS111 :SENSe:CORRection:COLLect:METhodlS111
CALIlS221 :SENSe:CORRection:COLLect:METhodlS221
CALIlFUL2 :SENSe:CORRection:COLLect:METhodlTPORT
CALIlONE2 :SENSe:CORRection:COLLect:METhodlOOPTPort
CALIlIMP :SENSe:CORRection:COLLect:METhodlIMPedance
```

■ Example

```
OUTPUT 717;"CALI NONE"
OUTPUT 717;"CALI?"
ENTER 717;A$
OUTPUT 717;":SENS:CORR:COLL:METH NONE"
OUTPUT 717;":SENS:CORR:COLL:METH?"
ENTER 717;A$
```

CALK{APC7|APC35|N50|N75|USED}

Selects one of the default calibration kits available for different connector types. (Network and impedance analyzer only) (CAL KIT:7mm, 3.5mm, N 50 ohm, N 75 ohm, or USER KIT under **Cal**)

Parameter	Description
APC7	7 mm
APC35	3.5 mm
N50	Type-N 50 Ω
N75	Type-N 75 Ω
USED	User-defined

■ Query Response

{APC7|APC35|N50|N75|USED} <new line><END>

■ Equivalent SCPI Command

```
CALK<APC7> :SENSe:CORRection:CKIT<APC7>
CALK<APC35> :SENSe:CORRection:CKIT<APC35>
CALK<N50> :SENSe:CORRection:CKIT<N50>
CALK<N75> :SENSe:CORRection:CKIT<N75>
CALK<USED> :SENSe:CORRection:CKIT<UDEFined>
```

■ Example

```
OUTPUT 717;"CALC APC7"
OUTPUT 717;"CALC?"
ENTER 717;A$
OUTPUT 717;":SENS:CORR:CKIT APC7"
```

CALS<numeric>

Provides the tabular listing of the standard definitions. (Network and impedance analyzer only) (STD NO.1 to STD NO.8 under **Copy**); No query)

Parameter	Range	Unit
<numeric>	1 to 8	

■ Equivalent SCPI Command

```
CALS<1> :DISPlay[:WINDow]:TEXT4:PAGEL1
:DISPlay[:WINDow]:TEXT4:STATeL{ON|1}
CALS<2> :DISPlay[:WINDow]:TEXT5:PAGEL1
:DISPlay[:WINDow]:TEXT5:STATeL{ON|1}
CALS<3> :DISPlay[:WINDow]:TEXT6:PAGEL1
:DISPlay[:WINDow]:TEXT6:STATeL{ON|1}
CALS<4> :DISPlay[:WINDow]:TEXT7:PAGEL1
:DISPlay[:WINDow]:TEXT7:STATeL{ON|1}
CALS<5> :DISPlay[:WINDow]:TEXT8:PAGEL1
:DISPlay[:WINDow]:TEXT8:STATeL{ON|1}
```

CALS \square *<numeric>*

CALS \square 6 :DISPlay[:WINDow]:TEXT9:PAGEL \square 1
 :DISPlay[:WINDow]:TEXT9:STATe \square {ON|1}

CALS \square 7 :DISPlay[:WINDow]:TEXT10:PAGEL \square 1
 :DISPlay[:WINDow]:TEXT10:STATe \square {ON|1}

CALS \square 8 :DISPlay[:WINDow]:TEXT11:PAGEL \square 1
 :DISPlay[:WINDow]:TEXT11:STATe \square {ON|1}

CBRI \square *<numeric>*[PCT]

Adjusts the brightness of the color being modified. (BRIGHTNESS under Display); No equivalent SCPI command)

Parameter	Range	Unit
<i><numeric></i>	0 to 100	%

■ Query Response

{*numeric*} <new line><END>

CENT \square *<numeric>*[HZ|KHZ|MAHZ|GHZ|DBM]

Defines the center value of the sweep range, or the center value of the segment to be edited in the list sweep table. (Center, or CENTER under Sweep)

Parameter	Range	Unit
<i><numeric></i>	100000 (-100 k) to 1.8199999999 \times 10 ⁹ (-1.8199999999 G) (network analyzer)	Hz (frequency)
	0 to 1.819999999902 \times 10 ⁹ (-1.819999999902 G) (spectrum analyzer)	
	-70 to +20 (network analyzer)	dBm (power)

■ Query Response

{*numeric*} <new line><END>

■ Equivalent SCPI Command

Center :SENSe:FREQuency:CENTer \square *<numeric>* (frequency) or
 :SOURce:POWer:CENTer \square *<numeric>* (power)

CENTER under Sweep :SENSe:LIST:SEGMENT:FREQuency:CENTer \square *<numeric>*
 (List sweep table)

■ Example

OUTPUT 717;"CENT 899.95MAHZ"

CHAD \square *<string>*

Specifies changing the current directory of a DOS format disk. (**CHANGE DIRECTORY** under **Save**); No query

Parameter	Description
<i><string></i>	Directory path

- Equivalent SCPI Command

:MMEMory:CDIRectory \square *<string>*

- Example

```
OUTPUT 717;"CHAD ""..""
```

CHAN1

Selects channel 1 as the active channel. (**Ch 1**)

- Query Response

{0|1} <new line><END>

- Equivalent SCPI Command

```
:INSTrument[:SElect]  $\square$  CH1 or :INSTrument:NSElect  $\square$  1
:INSTrument:STATe  $\square$  {ON|1}
```

- Example

```
OUTPUT 717;"CHAN1"
OUTPUT 717;":INST CH1"
OUTPUT 717;":INST:STAT ON"
```

CHAN2

Selects channel 2 as the active channel. (**Ch 2**)

- Query Response

{0|1} <new line><END>

- Equivalent SCPI Command

```
:INSTrument[:SElect]  $\square$  CH2 or :INSTrument:NSElect  $\square$  2
:INSTrument:STATe  $\square$  {ON|1}
```

CHAN2

CIRF{RI|LIN|LOG|RX|GB|SWR}

Selects format to readout the value of a Smith, polar, or admittance chart using markers. (Network and impedance analyzer only) (REAL IMAG, LIN MAG PHASE, LOG MAG PHASE, R+jX, G+jB, SWR PHASE under **Utility**)

Parameter	Description
RI	Real and imaginary form
LIN	Linear magnitude and phase form
LOG	Log magnitude and phase form
RX	Complex impedance form (R+jX)
GB	Complex admittance form (G+jB)
SWR	SWR and phase form

■ Query Response

{RI|LIN|LOG|RX|GB|SWR} <new line><END>

■ Equivalent SCPI Commands

CIRF{RI} :CALCulate:EVALuate:R:FORMat{LR}IMaginary
CIRF{LIN} :CALCulate:EVALuate:R:FORMat{LML}IPhase
CIRF{LOG} :CALCulate:EVALuate:R:FORMat{LML}OPhase
CIRF{RX} :CALCulate:EVALuate:R:FORMat{LR}X
CIRF{GB} :CALCulate:EVALuate:R:FORMat{LGB}
CIRF{SWR} :CALCulate:EVALuate:R:FORMat{L}SWRPhase

■ Example

OUTPUT 717;"CIRF GB"

CLAD

Completes the class assignment and stores it. (Network and impedance analyzer only) (CLASS DONE (SPE'D) under **Cal**); No query)

■ Equivalent SCPI Command

:SENSe:CORRection:CKIT:SAVE{L}CLASs

■ Example

OUTPUT 717;"CLAD"

OUTPUT 717;":SENS:CORR:CKIT:SAVE CLAS"

CLASIMP{A|B|C}

Selects and acquires the impedance calibration classes. (CALIBRATION OPEN, SHORT, or LOAD under **Cal**), respectively; No query; Impedance analyzer only)

The order in which you acquire the OPEN, SHORT, and LOAD is changable. You can suspend a calibration sequence and do a different operation, and then resume the calibration sequence.

■ Equivalent SCPI Command

:SENSe:CORRection1:COLLect[:ACquire] {STANdard1|STANdard2|STANdard3}

CLASS11{A|B|C}

Selects port 1 (S11) calibration standard class: S11A (open), S11B (short), or S11C (load). (Network analyzer only) ([S11] : OPEN, SHORT, LOAD under Cal); No query

- Equivalent SCPI Command

:SENSe:CORRection:COLLect[:ACQuire]LSTANdard{1|2|3}

CLASS22{A|B|C}

Selects port 2 (S22) calibration standard class: S22A (open), S22B (short), or S22C (load). (Network analyzer only) ([S22] : OPEN, SHORT, LOAD under Cal); No query

- Equivalent SCPI Command

:SENSe:CORRection:COLLect[:ACQuire]LCS22{A|B|C}

CLEL

Clears the entire list. (CLEAR LIST under Sweep); No query

- Equivalent SCPI Command

:SENSe:LIST:CLEar

CLES

Clears the Status Byte register, the Standard Event Status register, the Event Status register B (Instrument Event Status register), and the Operational Status register. (No query)

- Equivalent Common Command

*CLS

CNTS<numeric>[HZ|KHZ|MAHZ|GHZ]

Changes the step size for the center frequency function. (CENTER STEP SIZE under Center)

Parameter	Range	Unit
<numeric>	0 to 1.8x10 ⁹ (=1.8 G)	Hz

- Query Response

{numeric} <new line><END>

- Equivalent SCPI Command

:SENSe:FREQuency:CENTer:STEP[:INCRement]L<numeric>

- Example

OUTPUT 717;"CNTS 1MAHZ"

CNTS \square <numeric> [HZ|KHZ|MAHZ|GHZ]

CNTSAUTO \square {OFF|ON|0|1}

Sets CENTER step policy. (STEP SIZE AUTO man under Center)

Parameter	Description
OFF or 0	Linear step
ON or 1	1-2-5 step

■ Query Response

{0|1} <new line><END>

■ Equivalent SCPI Commands

:SENSe:FREQuency:CENTer:STEP[:INCRement]:AUTO \square {OFF|ON|0|1}

COLO \square <parameter>

Specifies the display element to change color. (CH1 DATA, CH1 MEM LIMIT LN, CH2 DATA, CH2 MEM LIMIT LN, GRATICULE, IBASIC, PEN 1, PEN 2, PEN 3, PEN 4, PEN 5, PEN 6, TEXT, WARNING under Display)

Parameter	Description
CH1D	Channel 1 data
CH1M	Channel 1 memory and limit lines
CH2D	Channel 2 data
CH2M	Channel 2 memory and limit lines
GRAT	Graticule and a portion of softkey text
WARN	Warning annotation
TEXT	All the non-data text
IBT	Text on the BASIC screen (Option 1C2 only)
PEN1	Pen 1 (Option 1C2 only)
PEN2	Pen 2 (Option 1C2 only)
PEN3	Pen 3 (Option 1C2 only)
PEN4	Pen 4 (Option 1C2 only)
PEN5	Pen 5 (Option 1C2 only)
PEN6	Pen 6 (Option 1C2 only)

■ Query response

{CH1D|CH1M|CH2D|CH2M|WARN|TEXT|GRAT|IBT|PEN1|PEN2|PEN3|PEN4|PEN5|PEN6}
<new line><END>

■ Equivalent SCPI Command

- COLO□CH1D :DISPlay:CMAP:COLor1:HSL□<numeric (hue)> , <numeric (sat)> , <numeric (lum)>
- COLO□CH1M :DISPlay:CMAP:COLor2:HSL□<numeric (hue)> , <numeric (sat)> , <numeric (lum)>
- COLO□CH2D :DISPlay:CMAP:COLor3:HSL□<numeric (hue)> , <numeric (sat)> , <numeric (lum)>
- COLO□CH2M :DISPlay:CMAP:COLor4:HSL□<numeric (hue)> , <numeric (sat)> , <numeric (lum)>
- COLO□GRAT :DISPlay:CMAP:COLor5:HSL□<numeric (hue)> , <numeric (sat)> , <numeric (lum)>
- COLO□WARN :DISPlay:CMAP:COLor6:HSL□<numeric (hue)> , <numeric (sat)> , <numeric (lum)>
- COLO□TEXT :DISPlay:CMAP:COLor7:HSL□<numeric (hue)> , <numeric (sat)> , <numeric (lum)>
- COLO□IBT :DISPlay:CMAP:COLor8:HSL□<numeric (hue)> , <numeric (sat)> , <numeric (lum)>
- COLO□PEN1 :DISPlay:CMAP:COLor9:HSL□<numeric (hue)> , <numeric (sat)> , <numeric (lum)>
- COLO□PEN2 :DISPlay:CMAP:COLor10:HSL□<numeric (hue)> , <numeric (sat)> , <numeric (lum)>
- COLO□PEN3 :DISPlay:CMAP:COLor11:HSL□<numeric (hue)> , <numeric (sat)> , <numeric (lum)>
- COLO□PEN4 :DISPlay:CMAP:COLor12:HSL□<numeric (hue)> , <numeric (sat)> , <numeric (lum)>
- COLO□PEN5 :DISPlay:CMAP:COLor13:HSL□<numeric (hue)> , <numeric (sat)> , <numeric (lum)>
- COLO□PEN6 :DISPlay:CMAP:COLor14:HSL□<numeric (hue)> , <numeric (sat)> , <numeric (lum)>

Parameter	Range	Unit
<numeric (hue)>	(Hue) 0 to 100, circular, with a value of 0 resulting in the same hue as a value of 100. The approximate color is (starting at 0): red, orange, yellow, green, cyan, blue, magenta, and back to red.	%
<numeric (sat)>	(Saturation) 0 to 100, with 0 specifying no color (only white or gray, depending on intensity) and 1 specifying no white.	%
<numeric (lum)>	(Luminance) 0 to 100, with 0 resulting in black and 1 resulting in the brightest color available.	%

□ Query Response

{numeric (hue)}, {numeric (sat)}, {numeric (lum)} <new line><END>

■ Example

OUTPUT 717;"COLO CH1D"

OUTPUT 717;":DISP:CMAP:COL:HSL 17,100,100"

COLO \square <parameter>

COLOR \square <numeric>[PCT]

Adjusts the degree of whiteness of the color being modified. (COLOR under **Display**); No equivalent SCPI Command)

Parameter	Range	Unit
<numeric>	0 to 100	%

■ Query response

{numeric} <new line><END>

COMC{A|B|C}

Measures the standards for the fixture compensation. (COMPEN OPEN, SHORT, or LOAD under **Cal**); No query; Impedance analyzer only)

Parameter	Description
A	Measures OPEN.
B	Measures SHORT.
C	Measures LOAD.

■ Equivalent SCPI Commands

COMCA :SENSe:CORRection2:COLLect[:ACQuire] \square STANdard1
COMCB :SENSe:CORRection2:COLLect[:ACQuire] \square STANdard2
COMCC :SENSe:CORRection2:COLLect[:ACQuire] \square STANdard3

COMCDAT{A|B|C} \square {OFF|ON|0|1}

Sets the OPEN, SHORT, and LOAD fixture compensation ON or OFF. (OPEN ON off, SHORT ON off, or LOAD ON off under **Cal**); Impedance analyzer only)

Parameter	Description
A	Uses OPEN compensation data.
B	Uses SHORT compensation data
C	Uses LOAD compensation data
ON or 1	Turns on the selected data.
OFF or 0	Turns off the selected data.

■ Query response

{1|0} <new line><END>

■ Equivalent SCPI Commands

COMCDATA {ON|OFF} :SENSe:CORRection2:OPEN \square {ON|OFF|1|0}
COMCDATB {ON|OFF} :SENSe:CORRection2:SHORT \square {ON|OFF|1|0}
COMCDATC {ON|OFF} :SENSe:CORRection2:LOAD \square {ON|OFF|1|0}

COMKDONE

Complete modifying the fixture compensation kit. (KIT DONE (MODIFIED) under **Cal**)
COMPEN KIT [USER] MODIFY [USER]; Impedance analyzer only)

- Equivalent SCPI Command

```
:SENSE:CORRection2:CKIT:SAVE
```

COMP

Call the fixture compensation menu. You need send this command before sending COMC.
(COMPEN MENU under **Cal**) **FIXTURE COMPEN**; No query; Impedance analyzer only)

- Equivalent SCPI Command

```
:SENSE:CORRection2:COLLect:METHODIMPedance
```

COMS

Displays the fixture compensation definition on the display. (**COMPEN KIT DEFINITION** under **Copy**); No query; Impedance analyzer only)

- Equivalent SCPI Commands

```
DISPlay[:WINDow]:TEXT20:PAGE 1  

DISPlay[:WINDow]:TEXT20:STATe ON
```

COMSDONE

Complete defining the standard for the fixture compensation kit. (**STD DONE (DEFINED)** under **Cal**) **COMPEN KIT [USER] MODIFY [USER]**; Impedance analyzer only)

- Equivalent SCPI Command

```
:SENSE:CORRection2:CKIT:STANdard:SAVE
```

CONT

Triggers sweep automatically and continuously and the trace is updated with each sweep.
(CONTINUOUS under **Trig**)

- Query Response

```
{0|1} <new line><END>
```

- Equivalent SCPI Command

```
:INITiate:CONTInuous{1|ON}
```

CONT

CONV<parameter>

Selects the measurement data conversion setting (impedance, admittance, or multiple phase). (Network analyzer only) (OFF, Z:Refl, Z:Trans, Y:Refl, Y:Trans, 1/S, 4xPHASE, 8xPHASE, 16xPHASE under **Meas**)

Parameter	Description
OFF	Conversion OFF
ZREF	Z: reflection
ZTRA	Z: transmission
YREF	Y: reflection
YTRA	Y: transmission
ONEDS	Reciprocal (1/S)
MP4	Multiply phase by 4
MP8	Multiply phase by 8
MP16	Multiply phase by 16

■ Query Response

```
{OFF|ZREF|ZTRA|YREF|YTRA|ONEDS|MP4|MP8|MP16} <new line><END>
```

■ Equivalent SCPI Command

```
CONV<OFF> :CALCulate:MATH1[:EXPRession]:NAME< >""  
CONV<ZREF> :CALCulate:MATH1[:EXPRession]:NAME< >"ZREF"  
CONV<ZTRA> :CALCulate:MATH1[:EXPRession]:NAME< >"ZTRA"  
CONV<YREF> :CALCulate:MATH1[:EXPRession]:NAME< >"YREF"  
CONV<YTRA> :CALCulate:MATH1[:EXPRession]:NAME< >"YTRA"  
CONV<ONEDS> :CALCulate:MATH1[:EXPRession]:NAME< >"INVS"  
CONV<MP4> :CALCulate:MATH1[:EXPRession]:NAME< >"MP4"  
CONV<MP8> :CALCulate:MATH1[:EXPRession]:NAME< >"MP8"  
CONV<MP16> :CALCulate:MATH1[:EXPRession]:NAME< >"MP16"
```

□ Query Response

```
{""| "ZREF"| "ZTRA"| "YREF"| "YTRA"| "INVS"| "MP4"| "MP8"| "MP16"} <new line><END>
```

■ Example

```
OUTPUT 717;"CONV ZREF"
```

```
OUTPUT 717;":CALC:MATH1:NAME ""ZREF""
```

COPA

Aborts a plot or print in progress. (**COPY ABORT** under **Copy**); No query)

■ Equivalent SCPI Command

```
:HCOPY:ABORT
```

COPT{OFF|ON|0|1}

Turns printing or plotting time and date (the time stamp function) ON or OFF.
(COPY TIME ON off under **Copy**)

Parameter	Description
OFF or 0	Time stamp function OFF
ON or 1	Time stamp function ON

- Query Response

{0|1} <new line><END>

- Equivalent SCPI Command

:HCOpy:ITEM:TDSamp:STATe{OFF|ON|0|1}

CORR{OFF|ON|0|1}

Turns error correction ON or OFF. (Network analyzer only) (CORRECTION ON off under **Cal**)

Parameter	Description
OFF or 0	Error correction OFF
ON or 1	Error correction ON

- Query Response

{0|1} <new line><END>

- Equivalent SCPI Command

:SENSe:CORRection[:STATe]{OFF|ON|0|1}

- Example

```
OUTPUT 717;"CORR OFF"
```

```
OUTPUT 717;"CORR?"
```

```
ENTER 717;A
```

```
OUTPUT 717;":SENS:CORR OFF"
```

```
OUTPUT 717;":SENS:CORR?"
```

```
ENTER 717;A
```

CORR␣{OFF|ON|0|1}

COUC␣{OFF|ON|0|1}

Sets the channel coupling of sweep parameter values. (Between network or between impedance analyzers only) (COUPLED CH ON off under **Sweep**)

Parameter	Description
OFF or 0	Channel coupling OFF
ON or 1	Channel coupling ON

■ Query Response

{0|1} <new line><END>

■ Equivalent SCPI Command

:INSTrument:COUPlE␣{OFF|ON|0|1}

CRED␣<string>

Create a new directory in a DOS format disk. (CREATE DIRECTORY under **Save**; No query)

Parameter	Description
<string>	Up to 8 characters for directory name (and up to 3 characters for extension)

■ Equivalent SCPI Command

:MMEMory:CREate:DIRectory␣<string>

■ Example

```
OUTPUT 717;"CRED ""DATA""
```

```
OUTPUT 717;":MMEM:CRE:DIR ""DATA""
```

CRSC \square {OFF|ON|0|1}

Selects the destination channel of the marker→ functions. When a marker→ function is performed, the sweep parameter or amplitude value of the destination channel is changed. (CROSS CHAN ON off under **Marker→**)

Parameter	Description
OFF or 0	Current active channel as the destination channel
ON or 1	Current inactive channel as the destination channel ¹

¹ Can be selected only when the dual channel function is ON.

■ Query Response

{0|1} <new line><END>

■ Equivalent SCPI Command

:CALCulate:EVALuate:EFFect:ON \square {1|2}

Parameter	Description
1	Current active channel as the destination channel
2	Current inactive channel as the destination channel

CWFREQ \square <numeric> [HZ|KHZ|MAHZ|GHZ]

Sets the frequency for power sweep. (Network and impedance analyzer only) (CWFREQ under **Source**)

Parameter	Range	Unit
<numeric>	100000 (= 100 k) to 1.82×10^9 (= 1.82 G)	Hz

■ Query Response

{numeric} <new line><END>

■ Equivalent SCPI Command

:SOURce:FREQuency[:CW] \square <numeric>

■ Example

OUTPUT 717;"CWFREQ 500MAHZ"

CWFREQ \square *<numeric>* [HZ|KHZ|MAHZ|GHZ]

DATAOVAL \square *<numeric>*

Defines the imaginary part of the offset value when using the Smith, Polar, and admittance chart format. (Network and impedance analyzer only) (AUX OFFSET VALUE under **Display**)

Parameter	Range	Unit
<i><numeric></i>	-500 to 500	

■ Query Response

{numeric} <new line><END>

■ Equivalent SCPI Command

:DATA[:DATA] \square LAOFF, *<numeric>*

DATGAIN \square *<numeric>*

Defines the gain value of the data math function. (GAIN under **Display**)

Parameter	Range	Unit
<i><numeric></i>	-100 to -0.001, or 0.001 to 100	

■ Query Response

{numeric} <new line><END>

■ Equivalent SCPI Command

:DATA[:DATA] \square LGAIN, *<numeric>*

DATMEM

Stores the current active measurement data in the memory of the active channel. (DATA \rightarrow MEMORY under **Display**); No query

■ Equivalent SCPI Command

:TRACe{1|2}:COPY \square MTRace, DTRace

■ Example

OUTPUT 717;":TRAC: COPY MTR, DTR"

DATVAL <numeric>

Defines the offset value. When using Smith, Polar, and admittance chart format, this command defines the real part of the offset value. (**OFFSET** under **Display**)

Parameter	Range	Unit
<numeric>	-500000 to 500000	

- Query Response

{numeric} <new line><END>

- Equivalent SCPI Command

:DATA[:DATA]LOFFS,<numeric>

DAYMYEAR

Changes the displayed date to the “day:month:year” format. (**DayMonYear** under **System**)

- Query Response

{0|1} <new line><END>

(0 for the “month:day:year” format; 1 for the “day:month:year” format.)

- Equivalent SCPI Command

:SYSTem:DATE:MODELDMY

DEFC

Returns all the color settings back to the factory-set default values. (**DEFAULT COLORS** under **Display**); No query)

- Equivalent SCPI Command

:DISPlay:CMAP:DEFAult

DEFEC

DEFEC{R1|C1|L1|C0}□<numeric>

Defines the specified equivalent circuit parameter for simulation. (PARAMETER R1, C1, L1, C0 under Display); Impedance analyzer only)

Parameter	Description
R1	Parameter R ₁
C1	Parameter C ₁
L1	Parameter L ₁
C0	Parameter C ₀

Parameter	Range	Unit
<numeric>	-1×10 ¹⁸ to 1×10 ¹⁸	F(C0, C1) H(L1) OHM(R1)

■ Query Response

<numeric> <new line><END>

■ Equivalent SCPI Command

:DATA[:DATA]□EQ{R1|C1|L1|C0},<numeric>

■ Example

```
OUTPUT @Hp4396;"DEFEC R1,350HM"
```

```
OUTPUT @Hp4396;"DEFEC? C1"
```

```
ENTER @Hp4396;C1
```

DEFGO

Returns the gain and offset values back to the default values (gain=1, offset=0). (DEFAULT GAIN & OFS under Display); No query)

■ Equivalent SCPI Command

:DATA[:DATA]□GAIN,1

:DATA[:DATA]□OFFS,0

■ Example

```
OUTPUT 717;"DEFGO"
```

```
OUTPUT 717;":DATA GAIN,1"
```

```
OUTPUT 717;":DATA OFFS,0"
```

DEFS□{1-8}

Defines the number of the calibration standards to be modified. (DEFINE STANDARD under **Cal**;
No query)

Parameter	Description
1	Standard no. 1 (SHORT)
2	Standard no. 2 (OPEN)
3	Standard no. 3 (LOAD)
4	Standard no. 4 (DEL/THRU)
5	Standard no. 5 (LOAD)
6	Standard no. 6 (LOAD)
7	Standard no. 7 (SHORT)
8	Standard no. 8 (OPEN)

■ Equivalent SCPI Command

:SENSe:CORRection:CKIT:SElect□STANdard{1-8}

□ Query response

{ STAN{1-8} } <new line><END>

■ Example

```
OUTPUT 717;"DEFS 1"
OUTPUT 717;":SENS:CORR:CKIT:SEL STAN1"
OUTPUT 717;":SENS:CORR:CKIT:SEL?"
ENTER 717;A$
```

DEFSLOAD{R|L}□<numeric>

Defines the LOAD standard by entering resistance and reactance value.
(LOAD: RESIST. (R) , INDUCT. (L) under **Cal** CAL KIT □ . Impedance analyzer only)

Parameter	Description
R	Resistance value of the LOAD fixture compensation standard.
X	Inductance value of the LOAD fixture compensation standard.

Parameter	Range	Unit
<numeric>	-1×10 ⁶ to 1×10 ⁶	Ω (R)
<numeric>	-1×10 ⁶ to 1×10 ⁶	H (L)

■ Query Response

{numeric} <new line><END>

■ Equivalent SCPI Command

DEFSLOADR :SENSe:CORRection1:CKIT:STANdard3:R□<numeric>

DEFSLOADL :SENSe:CORRection1:CKIT:STANdard3:L□<numeric>

DEFSOPEN{G|C}□□<numeric>

Defines the OPEN standard by entering conductance and capacitance value.

(OPEN: CONDUCT. (G), CAP. (C) under CAL KIT . Impedance analyzer only)

Parameter	Description
G	Conductance value of the OPEN fixture compensation standard.
C	Capacitance value of the OPEN fixture compensation standard.

Parameter	Range	Unit
<numeric>	-1×10^6 to 1×10^6	S (G)
<numeric>	-1×10^{-9} to 1×10^{-9}	F (C)

■ Query Response

{numeric} <new line><END>

■ Equivalent SCPI Command

DEFSOPENG SENSE:CORRection1:CKIT:STANdard1:G□□<numeric>

DEFSOPENC SENSE:CORRection1:CKIT:STANdard1:C□□<numeric>

■ Example

```
OUTPUT @Hp4396;"DEFSOPEN G,OS"
```

```
OUTPUT @Hp4396;"DEFSOPEN C,53E-6F"
```

```
OUTPUT @Hp4396;"DEFSOPEN? G"
```

```
ENTER @Hp4396;G
```

```
OUTPUT @Hp4396;"SENS:CORR:CKIT:STAN1:G OS;C 53E-6F"
```

DEFSSHOR{R|L}□□<numeric>

Defines the SHORT calibration standard by entering resistance and inductance value.

(SHORT: RESIST. (R), INDUCT. (L) under CAL KIT . Impedance analyzer only)

Parameter	Description
R	Resistance value of the SHORT fixture compensation standard.
L	Inductance value of the SHORT fixture compensation standard.

Parameter	Range	Unit
<numeric>	-1×10^6 to 1×10^6	Ω (R)
<numeric>	-1×10^6 to 1×10^6	H (L)

■ Query Response

{numeric} <new line><END>

■ Equivalent SCPI Command

DEFSSHORR SENSE:CORRection1:CKIT:STANdard2:R□□<numeric>

DEFSSHORL SENSE:CORRection1:CKIT:STANdard2:L□□<numeric>

■ Example

```

OUTPUT @Hp4396;"DEFSSHORT R,OOHM"
OUTPUT @Hp4396;"DEFSSHORT L,OH"

OUTPUT @Hp4396;"DEFSSHORT? R"
ENTER @Hp4396;R

OUTPUT @Hp4396;"SENS:CORR:CKIT:STAN2:R OOHM;L OH"

```

DET{POS|NEG|SAM}

Selects the detection mode for the active channel. (Spectrum analyzer only) (POS PEAK, NEG PEAK, SAMPLE under **Meas**)

Parameter	Description
POS	Positive Detection
NEG	Negative Detection
SAM	Sample Detection

■ Query Response

```
{POS|NEG|SAM} <new line><END>
```

■ Equivalent SCPI Command

```
:SENSe:DETECTOR[:FUNCTION]{POSitive|NEGative|SAMple}
```

■ Example

```
OUTPUT 717;"DET POS"
```

DFLT

Returns the plotting parameters to their default values. (DEFAULT SETUP under **Copy**; No query)

■ Equivalent SCPI Command

```
:HCOPY:DEFAULT
```

DHOLD{OFF|MAX|MIN}

Selects the data hold operation. When the format is changed, the value held is initiated. (HOLD: OFF, MAX, MIN under **Display**)

Parameter	Description
OFF	Data hold operation is turned off
MAX	Maximum data hold
MIN	Minimum data hold

DHOLD {OFF|MAX|MIN}

■ Query Response

{OFF|MAX|MIN} <new line><END>

■ Equivalent SCPI Command

```
DHOLD OFF      :CALCulate:AVERage:STATe OFF
DHOLD MAX      :CALCulate:AVERage:TYPE MAXimum
                :CALCulate1:AVERage:STATe ON
DHOLD MIN      :CALCulate:AVERage:TYPE MINimum
                :CALCulate1:AVERage:STATe ON
```

■ Example

```
OUTPUT 717;"DHOLD MAX"
OUTPUT 717;"DHOLD?"
ENTER 717;A$

OUTPUT 717;":CALC:AVER:TYPE MAX"
OUTPUT 717;":CALC:AVER:STAT ON"

OUTPUT 717;":CALC:AVER:TYPE?"
ENTER 717;A$
OUTPUT 717;":CALC:AVER:STAT?"
ENTER 717;A
```

DISA {ALLI|HIHB|ALLB|BASS}

Selects the display allocation mode. (Option 1C2 only) (DISPLAY ALLOCATION under **Display**)

Parameter	Description
ALLI	All instrument
HIHB	Half instrument and half HP Instrument BASIC
ALLB	All HP Instrument BASIC
BASS	HP Instrument BASIC status

■ Query Response

{ALLI|HIHB|ALLB|BASS} <new line><END>

■ Equivalent SCPI Command

```
DISA ALLI      :DISPlay[:WINDow]:ALLOCATION INSTRument
DISA HIHB      :DISPlay[:WINDow]:ALLOCATION HIHB
DISA ALLB      :DISPlay[:WINDow]:ALLOCATION BASic
DISA BASS      :DISPlay[:WINDow]:ALLOCATION BStatus
```

■ Example

```
OUTPUT 717;"DISA HIHB"
OUTPUT 717;"DISA?"
ENTER 717;A$
```

DISECIRC

Displays the equivalent circuit models. (SELECT EQV CKT [A] under **Display**); Impedance analyzer only)

Parameter	Description
OFF or 0	Turns off the equivalent circuit parameter display.
ON or 1	Turns on the equivalent circuit parameter display.

- Query Response

{0|1} <new line><END>

- Equivalent SCPI Command

:DISPlay[:WINDow]:TEXT19:STATe {OFF|ON|0|1}

DISECPARA {OFF|ON|0|1}

Displays the equivalent circuit parameters. (DISP EQV PARM [ON] or [OFF] under **Display**); Impedance analyzer only)

Parameter	Description
OFF or 0	Turns off the equivalent circuit parameter display.
ON or 1	Turns on the equivalent circuit parameter display.

- Query Response

{0|1} <new line><END>

- Equivalent SCPI Command

:DISPlay[:WINDow]:TEXT18:STATe {OFF|ON|0|1}

DISF {DOS|LIF}

Selects the disk format (LIF or DOS) to be used when initializing a new disk. (FORMAT [.] under **Save**); No equivalent SCPI command)

Parameter	Description
DOS	Disk Operating System format
LIF	Logical Interchange format

- Query Response

{DOS|LIF} <new line><END>

- Example

OUTPUT 717; "DISF DOS"

DISFL{DOS|LIF}

DISL

Displays the list sweep table on the display. (DISLAY LIST under Copy; No query)

■ Equivalent SCPI Command

```
:DISPlay[:WINDow]:TEXT{12|13}:PAGE1
```

```
:DISPlay[:WINDow]:TEXT{12|13}:STATe{ON|1}
```

(TEXT12 for the "start & stop" format; TEXT13 for the "center & span" format)

DISLLIST

Displays the limit testing table on the display. (DISPLAY LIST under Copy; No query)

■ Equivalent SCPI Command

```
:DISPlay[:WINDow]:TEXT{14|15}:PAGE1
```

```
:DISPlay[:WINDow]:TEXT{14|15}:STATe{ON|1}
```

(TEXT14 for the "upper & lower" format; TEXT15 for the "middle & delta" format)

DISMAMP{UL|MD}

Selects the amplitude format to display the limit testing table to list on the screen.

(DISP MODE: UPR & LWR, MID & DLT under Copy; No equivalent SCPI command)

Parameter	Description
UL	Upper and lower format
MD	Middle and delta format

■ Query Response

```
{UL|MD} <new line><END>
```

■ Example

```
OUTPUT 717;"DISMAMP UL"
```

```
OUTPUT 717;"DISMAMP?"
```

```
ENTER 717;A$
```

DISMPRM{STSP|CTSP}

Selects the sweep parameter range format to display the list sweep table on the screen.

(DISP MODE: ST & SP, CTR & SPAN under Copy; No equivalent SCPI command)

Parameter	Description
STSP	Start and stop format
CTSP	Center and span format

■ Query Response

```
{STSP|CTSP} <new line><END>
```

- Example

```
OUTPUT 717;"DISMPRM STSP"
```

DISP{DATA|MEMO|DATM}

Selects the display trace type. (DISPLAY: DATA, MEMORY, DATA and MEMORY under **Display**)

Parameter	Description
DATA	Current data trace
MEMO	Memory trace
DATM	Current data and memory traces

- Query Response

```
{DATA|MEMO|DATM} <new line><END>
```

- Equivalent SCPI Command

```
DISPDATA :DISPlay[:WINDow]:TRACe1:STATe{ON|1}
           :DISPlay[:WINDow]:TRACe2:STATe{OFF|0}

DISPMEMO :DISPlay[:WINDow]:TRACe1:STATe{OFF|0}
           :DISPlay[:WINDow]:TRACe2:STATe{ON|1}

DISPDATM :DISPlay[:WINDow]:TRACe1:STATe{ON|1}
           :DISPlay[:WINDow]:TRACe2:STATe{ON|1}
```

- Example

```
OUTPUT 717;"DISP DATA"
OUTPUT 717;":DISP:TRAC1:STAT ON"
OUTPUT 717;":DISP:TRAC2:STAT OFF"
```

DMKR{ON|FIX|TRAC|OFF}

Displays the Δmarker (ON, FIX, TRAC) at the point of the marker and the marker mode changes to the Δmode. Erases (OFF) the Δmarker and the Δmode is turned off. (ΔMKR, FIXED ΔMKR, TRACKING ΔMKR, ΔMODE OFF under **Marker**)

Parameter	Description
ON	Puts the Δmarker on a current position of the marker.
FIX	Sets a user-specified fixed reference marker.
TRAC	Puts a Δmarker at the present active marker position and turns on the tracking Δmarker.
OFF	Turns off the Δmode.

DMKR{ON|FIX|TRAC|OFF}

■ Query Response

{ON|FIX|TRAC|OFF} <new line><END>

■ Equivalent SCPI Command

```
DMKR|ON      :DISPlay[:WINDow]:TRACe{[1]|2}:MARKer[1]:RELative|{ON|1}
              :DISPlay[:WINDow]:TRACe{[1]|2}:MARKer[1]:RELative:REFerence|MARKer
DMKR|FIX     :DISPlay[:WINDow]:TRACe{[1]|2}:MARKer[1]:RELative|{ON|1}
              :DISPlay[:WINDow]:TRACe{[1]|2}:MARKer[1]:RELative:REFerence|FIXed
DMKR|TRAC    :DISPlay[:WINDow]:TRACe{[1]|2}:MARKer[1]:RELative|{ON|1}
              :DISPlay[:WINDow]:TRACe{[1]|2}:MARKer[1]:RELative:REFerence|TRACked
DMKR|OFF     :DISPlay[:WINDow]:TRACe{[1]|2}:MARKer[1]:RELative|{OFF|0}
```

(TRACe[1] for the data trace; TRACe2 for the memory trace)

■ Example

OUTPUT 717;"DMKR ON"

OUTPUT 717;":DISP:TRAC:MARK:REL ON"

OUTPUT 717;":DISP:TRAC:MARK:REL:REF MARK"

DMKRAUV|<numeric>

Sets the auxiliary amplitude value of the fixed Δ marker. This command is used with a polar, Smith, or admittance chart. (Network and impedance analyzer only) (**DMKR AUX VALUE** under **Marker**)

Parameter	Range	Unit
<numeric>	-500000 to 500000	

■ Query Response

{numeric} <new line><END>

■ Equivalent SCPI Command

```
:CALCulate:EVALuate:REFerence:Y2|<numeric>
```

■ Example

OUTPUT 717;"DMKRAUV 0"

DMKRPRM \square *<numeric>* [HZ|KHZ|MAHZ|GHZ|DBM]

Sets the sweep parameter value of the Δ marker. (**AMKR SWP PRM** under **Marker**)

Parameter	Range	Unit
<i><numeric></i>	Start value to stop value	Hz (frequency) dBm (power)

- Query Response

{numeric} <new line><END>

- Equivalent SCPI Command

:CALCulate:EVALuate:REFerence:X \square *<numeric>*

DMKRVAL \square *<numeric>*

Sets the amplitude value of the fixed Δ marker. (**AMKR VALUE** under **Marker**)

Parameter	Range	Unit
<i><numeric></i>	- 500000 to 500000	

- Query Response

{numeric} <new line><END>

- Equivalent SCPI Command

:CALCulate:EVALuate:REFerence:Y1 \square *<numeric>*

DONE

Completes the measurement of the selected standard calibration. (**DONE: LOADS**, **DONE: OPENS**, **DONE: SHORTS**, **DONE: THRU** under **Cal**); No query

- Equivalent SCPI Command

:SENSe:CORRection:COLLect:SAVE1

DSKEY

Disables the front panel keys and the rotary knob. To enable the keys and knob again, send the ENKEY command. (No query for the Simple command)

- Equivalent SCPI Command

:SYSTem:KLOCK \square {1|ON}

- Example

```
OUTPUT 717;"DSKEY"
```

```
OUTPUT 717;":SYST:KLOC ON"
```

DSKEY

DUAC $\{OFF|ON|0|1\}$

Selects the display of both measurement channels or the active channel only.
(DUAL CHAN ON off under **Display**)

Parameter	Description
OFF or 0	Active channel only
ON or 1	Both channels

■ Query Response

$\{0|1\}$ <new line><END>

■ Equivalent SCPI Command

```
DUAC ON      :INSTRument[:SElect] CH1
              :INSTRument:STATe {ON|1}
              :INSTRument[:SElect] CH2
              :INSTRument:STATe {ON|1}

DUAC OFF     :INSTRument[:SElect] {CH1|CH2}
              :INSTRument:STATe {OFF|0}
```

■ Example

```
OUTPUT 717;"DUAC ON"
OUTPUT 717;":INST CH1"
OUTPUT 717;":INST:STAT ON"
OUTPUT 717;":INST CH2"
OUTPUT 717;":INST:STAT ON"
```

EDITDONE

Completes editing the frequency sweep list. (**LIST DONE** under **Sweep**); No query)

■ Equivalent SCPI Command

```
:SENSe:LIST:SAVE
```

EDITLIML

Begins editing the limit line table. (**EDIT LIMIT LINE** under **System**); No query; No equivalent SCPI command)

EDITLIST

Begins editing the frequency sweep list. (**EDIT LIST** under **Sweep**); No query; No equivalent SCPI command)

ELED | <numeric> [S|MS|US|NS|PS|FS]

Adjusts the electrical delay to balance the phase of the DUT. (Network analyzer only)
 (ELECTRICAL DELAY under **Scale Ref**)

Parameter	Range	Unit
<numeric>	-10 to 10	s

■ Query Response

{numeric} <new line><END>

■ Equivalent SCPI Command

:SENSe:CORRection:EDELay2|<numeric>

ENKEY

Reenables the front panel keys and the rotary knob that have been disabled by the DSKEY command. (No query for the Simple command)

■ Equivalent SCPI Command

SYSTem:KLOCK|{OFF|0}

■ Example

OUTPUT 717;"ENKEY"

OUTPUT 717;":SYST:KLOC OFF"

EQUC|CIR{A|B|C|D|E}

Selects the equivalent circuit. (SELECT EQV CKT under **Display**). Impedance analyzer only)

Parameter	Description
CIRA	For coils with high core loss.
CIRB	For coils and resistance.
CIRC	For high-value resistors.
CIRD	For capacitors.
CIRE	For resonators.

■ Query Response

CIR{A|B|C|D|E}<new line><END>

■ Equivalent SCPI Command

:CALCulate:EVALuate:EPARameters:CIRCuit|{A|B|C|D|E}

■ Example

OUTPUT @Hp4396;"EQUC CIRA"

EQUC0?□<numeric>

Returns a C_0 at the specified frequency. For more information, see “EQUC0? value” in Appendix I. (No equivalent SCPI command; Network analyzer only)

Parameter	Range	Unit
<numeric>	0 to 1.82×10^9 (= 1.82 G)	Hz

■ Query Response

<numeric><new line><END>

EQUCPARA?

Executes six elements equivalent circuit analysis of a crystal resonator, and outputs parameters. For more information, see “EQUCPARA?” in Appendix I. (No equivalent SCPI command; Network analyzer only)

■ Query Response

See “EQUCPARA?” in Appendix I.

EQUCPARS?

Executes six elements equivalent circuit analysis of a crystal resonator, and outputs parameters. For more information, see “EQUCPARS?” in Appendix I. (No equivalent SCPI command; Network analyzer only)

■ Query Response

See “EQUCPARS?” in Appendix I.

EQUCPARS4?

Executes four elements equivalent circuit analysis of a crystal resonator, and outputs parameters. For more information, see “EQUCPARS4?” in Appendix I. (No equivalent SCPI command; Network analyzer only)

■ Query Response

See “EQUCPARS4?” in Appendix I.

EQUM?□<numeric>

Specifies how many points are used for an approximation of a admittance circle for EQUCPARA? and EQUCPARS? equivalent circuit analysis commands for the crystal resonator. EQUCPARA? (or EQUCPARS?) thins the measured points out for the specified points, then make circle approximation. When the EQUM parameter is set greater than the number of points, EQUCPARA? (or EQUCPARS?) uses all points for the circle approximation. Default value is 8. (Instrument BASIC EXECUTE executable; No equivalent SCPI command; Network analyzer only)

Parameter	Range	Unit
<numeric>	2 to 801	N/A

■ Query Response

<numeric><new line><END>

ESB?

Outputs the Event Status register B (Instrument Event Status register) value. (Query Only)

- Query Response

{*numeric*} <new line><END>

- Equivalent SCPI Command

:STATus:INSTRument[:EVENT]?

ESNB<numeric>

Enables the bits of Event Status register B (Instrument Event Status register).

Parameter	Range	Unit
<numeric>	Decimal expression of the contents of the register, 0 to 32767 ($-2^{15}-1$)	

- Query Response

{*numeric*} <new line><END>

- Equivalent SCPI Command

:STATus:INSTRument:ENABle<numeric>

EXPP{OFF|ON|0|1}

Turns on and off the expanded phase display. (EXP PHASE on OFF under **Format**; Impedance analyzer only)

Parameter	Description
OFF or 0	Turns off the expanded phase display.
ON or 1	Turns on the expanded phase display.

- Query Response

{0|1} <new line><END>

- Equivalent SCPI Command

EXPPLOFF :CALCulate:MATH1:STATeLOFF
:CALCulate:FORMatLPHASe

EXPPLOON :CALCulate:MATH1:STATeLOFF
:CALCulate:FORMatLUPHAsE

EXPP \square {OFF|ON|0|1}

FILC \square <string1>, <string2>, <string3>, <string4>

Copies files. (**COPY FILE** under **Save**); No query)

Parameter	Description
<string1>	Source file name
<string2>	Source device name ("DISK" or "MEMORY") ¹
<string3>	Destination file name
<string4>	Destination device name ("DISK" or "MEMORY")

¹ "DISK" for the built-in flexible disk drive; "MEMORY" for the RAM disk memory.

■ Equivalent SCPI Command

:MMEMory:COPIE \square <string1>, <string2>, <string3>, <string4>

■ Example

```
OUTPUT @Hp4396;"FILC ""DAT1.TXT"",""MEMORY"",""DAT1.TXT"",""DISK""
```

```
OUTPUT @Hp4396;":MMEM:COPIE ""DAT1.TXT"",""MEMORY"",""DAT1.TXT"",""DISK""
```

FIXE \square <numeric>

Sets the electrical length of the fixture. (**DEFINE EXTENSION** under **Meas**); Impedance analyzer only.)

Parameter	Range	Unit
<numeric>	-10 to 10	m

■ Query Response

{<numeric>} <new line> <END>

■ Equivalent SCPI Command

:SYSTem:FIXTure:DIStance \square <numeric>

FIXKDONE

Terminates the user fixture setting. (**DONE** under **Meas**); No query; Impedance analyzer only.)

■ Equivalent SCPI Command

:SYSTem:FIXTure:SAVE

FIXT \square {NONE|HP16191|HP16192|HP16193|HP16194|USED}

Specifies the fixture in use in order to select which electrical length (recorded in the analyzer) is to be used. (**FIXTURE:NONE**, **HP16191**, **HP16192**, **HP16193**, **HP16194**, **USED** under **Meas**); **SELECT FIXTURE**; Impedance analyzer only.)

■ Query Response

{NONE|HP16191|HP16192|HP16193|HP16194|USED} <new line> <END>

■ Equivalent SCPI Command

:SYSTEM:FIXTURE{NONE|HP16191|HP16192|HP16193|HP16194|USED}

FMT <parameter>

Selects the display format. (FORMAT: LOG MAG, PHASE, DELAY, SMITH [Re Im], POLAR [Re Im], LIN MAG, SWR, FORMAT: REAL, IMAGINARY, EXPANDED PHASE, ADMITTANCE [Re Im], FORMAT: SPECTRUM, NOISE, LIN Y-AXIS, LOG Y-AXIS, COPLEX PLANE under (Format))

Parameter	Description
LOGM	Log magnitude format (Network analyzer only)
PHAS	Phase format (Network analyzer only)
DELA	Delay format (Network analyzer only)
SMITH	Smith chart format (Network and impedance analyzer only)
POLA	Polar chart format (Network and impedance analyzer only)
LINM	Linear magnitude format (Network analyzer only)
SWR	SWR format (Network analyzer only)
REAL	Real format (Network analyzer only)
IMAG	Imaginary format (Network analyzer only)
EXPP	Expanded phase format (Network analyzer only)
ADMIT	Admittance Smith chart (Network and impedance analyzer only)
SPECT	Spectrum measurement (Spectrum analyzer only)
NOISE	Noise level measurement (Spectrum analyzer only)
LINY	Linear Y-axis measurement (Impedance analyzer only)
LOGY	Log Y-axis measurement (Impedance analyzer only)
COMP	Complex plane measurement (Impedance analyzer only)

■ Query Response

```
{LOGM|PHAS|DELA|SMITH|POLA|LINM|SWR|REAL|IMAG|EXPP|ADMIT|SPECT|NOISE|
LINY|LOGY|COMP} <new line><END>
```

■ Equivalent SCPI Command

```
FMTULOGM      :DISPlay[:WINDow]:TRACe{[1]|2}:GRATicule:FORMatURECTangle
                :CALCulate:FORMatUMLLOGarithmic

FMTUPHAS      :DISPlay[:WINDow]:TRACe{[1]|2}:GRATicule:FORMatURECTangle
                :CALCulate:FORMatUMLPHASe

FMTUDELA      :DISPlay[:WINDow]:TRACe{[1]|2}:GRATicule:FORMatURECTangle
                :CALCulate:FORMatUMLGDElay

FMTUSMITH     :DISPlay[:WINDow]:TRACe{[1]|2}:GRATicule:FORMatUMLSMITH
                :CALCulate:FORMatUMLCOMplex

FMTUPOLA      :DISPlay[:WINDow]:TRACe{[1]|2}:GRATicule:FORMatUMLPOLar
                :CALCulate:FORMatUMLCOMplex

FMTULINM     :DISPlay[:WINDow]:TRACe{[1]|2}:GRATicule:FORMatUMLRECTangle
                :CALCulate:FORMatUMLLINear

FMTUSWR       :DISPlay[:WINDow]:TRACe{[1]|2}:GRATicule:FORMatUMLRECTangle
                :CALCulate:FORMatUMLSWR
```

FMT \downarrow <parameter>

FMT \downarrow REAL	:DISPlay[:WINDow]:TRACe{[1] 2}:GRATICule:FORMat \downarrow RECTangle :CALCulate:FORMat \downarrow REAL
FMT \downarrow IMAG	:DISPlay[:WINDow]:TRACe{[1] 2}:GRATICule:FORMat \downarrow RECTangle :CALCulate:FORMat \downarrow IMAGinary
FMT \downarrow EXPP	:DISPlay[:WINDow]:TRACe{[1] 2}:GRATICule:FORMat \downarrow RECTangle :CALCulate:FORMat \downarrow UPHase
FMT \downarrow ADMIT	:DISPlay[:WINDow]:TRACe{[1] 2}:GRATICule:FORMat \downarrow ADMittance :CALCulate:FORMat \downarrow COMPLex
FMT \downarrow SPECT	:SENSe:FUNCTion \downarrow "POWER \downarrow {1 2 3 4}"
FMT \downarrow NOISE	:SENSe:FUNCTion \downarrow "POWER{1 2 3 4}:PSDdensity" (TRACe[1] for the data trace; TRACe2 for the memory trace.)
FMT \downarrow LIN	DISPlay[:WINDow]:TRACe{1 2}:GRATICule:FORMat RECTangle DISPlay[:WINDow]:TRACe{1 2}:X::SPACing LINear
FMT \downarrow LOG	DISPlay[:WINDow]:TRACe{1 2}:GRATICule:FORMat RECTangle DISPlay[:WINDow]:TRACe{1 2}:X::SPACing LOGarithmic
FMT \downarrow COMP	DISPlay[:WINDow]:TRACe{1 2}:GRATICule:FORMat CPLane CALCulate:FORMat:COMPLex

■ Example

```
OUTPUT @Hp4396;"FMT LOGM"  
OUTPUT @Hp4396;"FMT?"  
ENTER @Hp4396;A$  
  
OUTPUT @Hp4396;":DISP:TRAC:GRAT:FORM RECT"  
OUTPUT @Hp4396;":CALC:FORM MLOG"  
  
OUTPUT @Hp4396;":DISP:TRAC:GRAT:FORM?"  
ENTER @Hp4396;A$  
OUTPUT @Hp4396;":CALC:FORM?"  
ENTER @Hp4396;B$
```

FORM2

Sets the IEEE 32-bit floating point format to transfer trace data via HP-IB. See Appendix H for more information. (No query for the Simple command)

■ Equivalent SCPI Command

```
:FORMat[:DATA] $\downarrow$ REAL,32
```

FORM3

Sets the IEEE 64-bit floating point format to transfer the trace data via HP-IB. See Appendix H for more information. (No query for the Simple command)

■ Equivalent SCPI Command

```
:FORMat[:DATA] $\downarrow$ REAL,64
```

FORM4

Sets the ASCII transfer format to transfer the trace data via HP-IB. See Appendix H for more information. (No query for the Simple command)

- Equivalent SCPI Command

:FORMat[:DATA]␣ASCIi

FORM5

Sets MS-DOS format to transfer the trace data via HP-IB. See Appendix H for more information. (No query for the Simple command)

- Equivalent SCPI Command

:FORMat[:DATA]␣PACKed,32

FREQ

Blanks the displayed frequency notation for security purposes. Frequency notation cannot be restored except by sending the :SYSTEM:PRESet or *RST command, or by turning the power OFF and ON. (FREQUENCY BLANK under **Display**)

- Query Response

{0|1} <new line><END>

- Equivalent SCPI Command

:DISPlay:ANNotation:FREQuency␣{OFF|0}

:SYSTem:SECurity[:STATe]␣{ON|1}

FULL

Sets the SPAN to the maximum range. (FULL SPAN under **Span**; No query)

- Equivalent SCPI Command

:SENSe:FREQuency:SPAN:FULL (frequency) or

:SOURce:POWer:SPAN:FULL (power)

FWDI

Measures S_{21} isolation. (Network analyzer only) (FWD ISOL'N ISOL'N STD under **Cal**; No query)

- Equivalent SCPI Command

:SENSe:CORRection:COLLect[:ACQuire]␣FWDI

FWDM

Measures S_{11} load match. (Network analyzer only) (FWD. MATCH THRU under **Cal**; No query)

- Equivalent SCPI Command

:SENSe:CORRection:COLLect[:ACQuire]␣FWDM

FWDM

FWDT

Measures S_{21} frequency response. (FWD. TRANS. THRU under Cal); No query)

■ Equivalent SCPI Command

```
:SENSe:CORRection:COLLect[:ACQuire]LFWDT
```

GATCTL{LEV|EDG}

Specifies the gate trigger mode. (Option 1D6 only) (GATE CTL: LEVEL, EDGE under Trigger)

Parameter	Description
LEV	Level gate trigger mode
EDG	Edge gate trigger mode

■ Query Response

```
{LEV|EDG} <new line><END>
```

■ Equivalent SCPI Command

```
GATCTLLEV :SENSe:SWEep:GATed:TRIGgerLEVEL
```

```
GATCTLEDG :SENSe:SWEep:GATed:TRIGgerEDGE
```

GATDLY<numeric>[US|MS|S]

Sets the gate delay. (Option 1D6 only) (GATE DELAY under Trigger)

Parameter	Range	Unit
<numeric>	0.000002 (-2 μ) to 3.2	s

■ Query Response

```
{numeric} <new line><END>
```

■ Equivalent SCPI Command

```
:SENSe:SWEep:GATed:DELay<numeric>
```

■ Example

```
OUTPUT @Hp4396;"GATDLY 10US"
```

GATLEN□<numeric>[US|MS|S]

Sets the gate length. (Option 1D6 only) (GATE LENGTH under **Trigger**)

Parameter	Range	Unit
<numeric>	0.000002 (-2 μ) to 3.2	s

- Query Response

{numeric} <new line><END>

- Equivalent SCPI Command

:SENSe:SWEep:GATed:LENGth□<numeric>

- Example

```
OUTPUT @Hp4396;"GATLEN 100US"
```

```
OUTPUT @Hp4396;":SENS:SWE:GAT:LENG 100US"
```

GRAE□<string>

Changes the extension of HP-GL files for DOS format. The extension is automatically attached to the file name when an HP-GL file is saved. The factory setting is ".HPG". The modified extension is kept in SRAM even when power is turned OFF. (GRAPHICS [] under **Save**)

Parameter	Description
<string>	Extension name. Up to 3 characters

- Query Response

{string} <new line><END>

- Equivalent SCPI Command

:MMEMory:FNAME:EXTension1□<string>

- Example

```
OUTPUT @Hp4396;"GRAE ""HPG"""
```

GRODAPER□<numeric>[PCT]

Sets the aperture for the group delay measurement as a percentage of the span. (Network analyzer only) (GROUP DELY APERTURE under **Bw/Avg**)

Parameter	Range	Unit
<numeric>	0.25 to 20 (of span)	%

- Query Response

{numeric} <new line><END>

- Equivalent SCPI Command

:CALCulate:GDAPerture:APERTure□<numeric>

GRODAPER \lfloor *numeric* \rfloor [PCT]

HOLD

Freezes the data trace on the display. the analyzer stops sweeping and taking data. (SWEEP: HOLD under **Trigger**)

■ Query Response

{0|1} \langle new line \rangle \langle END \rangle

Parameter	Description
0	Sweeping (not hold mode)
1	Hold mode

■ Equivalent SCPI Command

```
:INITiate:CONTinuous  $\lfloor$  {OFF|0} $\rfloor$   
:ABORt
```

INID

Initializes the disk in the flexible disk drive or the RAM disk memory. (INITIALIZE under **Save**; No query)

■ Equivalent SCPI Command

```
:MMEmory:INITialize  $\lfloor$  string (msus)  $\rfloor$ , {LIF|DOS}
```

Parameter	Description
\langle <i>string (msus)</i> \rangle	"DISK" for the internal flexible disk drive "MEMORY" for the internal RAM disk memory

■ Example

```
OUTPUT @Hp4396;" :MMEM:INIT ""DISK"",DOS"
```

INP8IO?

Inputs data from the 4-bit parallel input to the analyzer, and outputs the data to a controller. (Query only)

■ Query Response

{*numeric*} \langle new line \rangle \langle END \rangle

■ Equivalent SCPI Command

```
:SYSTem:COMMunicate:PARAllel[:RECeive]:DATA?
```

INPUCALC{1-12}□<numeric (1)>,<numeric (2)>, ... ,<numeric (n)>

Stores the measurement calibration error coefficient set of real/imaginary pairs input via HP-IB into the analyzer's memory. See Appendix F for calibration array assignments. (Network and impedance analyzer only; No query)

Parameter	Description
<numeric>	Complex number (Data format: real, imaginary)

■ Equivalent SCPI Command

:DATA[:DATA]□CCO{1-12},{<numeric (1)>,<numeric (2)>, ... ,<numeric(n)>|<block>}

■ Example

```
DIM A(1:201,1:2)                NOP: 201
OUTPUT @Hp4396;"INPUCALC1 ";A(*)  Set the measurement calibration error coefficient.

DIM A(1:201,1:2)                NOP: 201
OUTPUT @Hp4396;":DATA CCO1, ";A(*) Set the measurement calibration error coefficient.
```

INPUCALK□<block>

Stores the calibration kit data transmitted by the OUTPCALK? command. (Network and impedance analyzer only) (No query)

Parameter	Description
<block>	Block data (Data format: HP 4396A internal format (714 bytes of binary data))

■ Equivalent SCPI Command

:DATA[:DATA]□CKIT,{<block>|<numeric (1)>,<numeric (2)>, ... ,<numeric (n)>}

■ Example

```
OUTPUT @Hp4396;"INPUCALK ";A$
OUTPUT @Hp4396;":DATA CKIT, ";A$
```

INPUCOMC{1|2|3}□<numeric>

Inputs data into the fixture compensation coefficient arrays. (No query; Impedance analyzer only.)

The analyzer handles a reflection coefficient data for the intermediate processing. Thus, the fixture compensation is performed for the reflection coefficient as follows:

$$\Gamma = \frac{\Gamma_M - A}{B \times (\Gamma_M - A) + C}$$

Where,

- A, B, and C Fixture compensation coefficients. (complex)
- Γ_M Measured reflection data. (converted from V and I.)
- Γ Corrected reflection data.

By using this command, you can change the contents of the fixture compensation coefficient arrays.

INPUCOMC{1|2|3}␣<numeric>

Parameter	Description
1	coefficient A
2	coefficient B
3	coefficient C
<numeric>	Complex number (Data format: real, imaginary)

■ Equivalent SCPI Command

:DATA[:DATA]␣CMP{1|2|3},{<numeric>

■ Example

```
OUTPUT @Hp4396;"INPUCOMC1 ";Dat(*)
```

```
OUTPUT @Hp4396;"DATA CMP1, ";Dat(*)
```

INPUD

Executes a 3-term calibration by using real data which are set with INPULOAA, INPUOPEA, and INPUSHOA commands. (No equivalent SCPI command; No query; Network analyzer only)

INPUDATA␣<numeric (1)>,<numeric (2)>, ... ,<numeric (n)>

Inputs the error corrected data. (No query)

Parameter	Description
<numeric>	Complex number (Data format: real, imaginary) for the Network analyzer Real number for the Spectrum analyzer

■ Equivalent SCPI Command

DATA[:DATA]␣LDATA,{<numeric (1)>,<numeric (2)>, ... ,<numeric (n)>|<block>}

■ Example

```
DIM A(1:201,1:2) Network Analyzer, NOP: 201
```

```
! Set the error corrected data.
```

```
OUTPUT @Hp4396;"INPUDATA ";A(*)
```

```
DIM A(1:201,1:2)
```

```
! Set the error corrected data.
```

```
OUTPUT @Hp4396;" :DATA DATA, ";A(*)
```

INPUOPEA \square \langle numeric (1) \rangle , \langle numeric (2) \rangle , ... , \langle numeric (n) \rangle

INPUDTRC \square \langle numeric (1) \rangle , \langle numeric (2) \rangle , ... , \langle numeric (n) \rangle

Inputs data to DATA TRACE memory. (No query)

Parameter	Description
\langle numeric \rangle	Complex number (Data format: real, imaginary) for the Network analyzer Real number for the Spectrum analyzer

■ Equivalent SCPI Command

:TRACe[:DATA] \square DTR, { \langle numeric (1) \rangle , \langle numeric (2) \rangle , ... , \langle numeric (n) \rangle | \langle block \rangle }

■ Example

```
DIM A(1:201,1:2)                               Network analyzer, NOP: 201
! Set the trace data.
OUTPUT @Hp4396;"INPUDTRC ";A(*)

DIM A(1:201,1:2)
! Set the trace data.
OUTPUT @Hp4396;":TRAC DTR,";A(*)
```

INPULOAA \square \langle numeric (1) \rangle , \langle numeric (2) \rangle , ... , \langle numeric (n) \rangle

Inputs the real LOAD data array for a 3-term calubtaion. (No equivalent SCPI command; No query; Network analyzer only)

Parameter	Description
\langle numeric \rangle	Complex number (Data format: real, imaginary)

INPUOPEA \square \langle numeric (1) \rangle , \langle numeric (2) \rangle , ... , \langle numeric (n) \rangle

Inputs the real OPEN data array for a 3-term calubtaion. (No equivalent SCPI command; No query; Network analyzer only)

Parameter	Description
\langle numeric \rangle	Complex number (Data format: real, imaginary)

INPUOPEA \square \langle numeric (1) \rangle , \langle numeric (2) \rangle , ... , \langle numeric (n) \rangle

INPURAW {1-4} \square \langle numeric (1) \rangle , \langle numeric (2) \rangle , ... , \langle numeric (n) \rangle

Inputs raw data. (No query)

Parameter	Description
\langle numeric \rangle	Complex number (Data format: real, imaginary) for the Network analyzer Real number for the Spectrum analyzer

■ Equivalent SCPI Command

:DATA[:DATA] \square RAW{1-4}, { \langle numeric (1) \rangle , \langle numeric (2) \rangle , ... , \langle numeric (n) \rangle | \langle block \rangle }

■ Example

```
DIM A(1:201,1:2)           Network Analyzer, NOP: 201
! Set the raw data.
OUTPUT @Hp4396;"INPURAW1 ";A(*)

DIM A(1:201,1:2)
! Set the raw data.
OUTPUT @Hp4396;":DATA RAW1,";A(*)
```

INPUSHOA \square \langle numeric (1) \rangle , \langle numeric (2) \rangle , ... , \langle numeric (n) \rangle

Inputs the real SHORT data array for a 3-term calubtaion. (No equivalent SCPI command; No query; Network analyzer only)

Parameter	Description
\langle numeric \rangle	Complex number (Data format: real, imaginary)

INPZ \square {50|75} [OHM]

Sets the input impedance. (Spectrum analyzer only) (INPUT Z under **Cal**)

■ Query Response

{numeric} \langle new line \rangle \langle END \rangle

■ Equivalent SCPI Command

:INPut:IMPedance \square \langle numeric \rangle

■ Example

```
OUTPUT @Hp4396;"INPZ 50"
```

INTE□<numeric>[PCT]

Sets the display intensity as a percent of the brightest setting. (INTENSITY under **Display**)

Parameter	Range	Unit
<value>	0 to 100 (simple command)	%
<value>	0 to 1 (SCPI command)	

- Query Response

{numeric} <new line><END>

- Equivalent SCPI Command

:DISPlay:BRIGhtness□<numeric>

ISOD

Completes isolation calibration. The error coefficients are calculated and stored. (Network analyzer only) (ISOLATION DONE under **Cal**; No query)

- Equivalent SCPI Command

:SENSe:CORRection:COLLect:SAVE7

ISOL

Starts the isolation calibration. (Network analyzer only) (ISOLATION under **Cal**; No query)

- Equivalent SCPI Command

:SENSe:CORRection:COLLect[:ACQuire]□ISOL

KEY□<numeric>

Sends the key code for a key or a softkey on the front panel. This is equivalent to actually pressing a key. See Appendix G for key codes. (No query)

Parameter	Description
<numeric>	0 to 52

- Equivalent SCPI Command

:SYSTem:KEY□<numeric>

- Example

OUTPUT @Hp4396;"KEY 8" *Equivalent to pressing* **Ch1**.

KEY \square *<numeric>*

KITD

Completes the procedure to define user cal kit. (Network analyzer only)
(KIT DONE (MODIFIED) under **Cal**; No query)

- Equivalent SCPI Command
:SENSe:CORRection:CKIT:SAVE \square ALL

LABECOMK \square *<string>*

Modifies the label of user defined fixture compensation kit. (**LABEL KIT** under **Cal**; Impedance analyzer only.)

Parameter	Description
<i><string></i>	Up to ten characters.

- Query Response
<string> <new line> <END>
- Equivalent SCPI Command
:SENSe:CORRection2:CKIT:LABel \square *<string>*
- Example
OUTPUT @Hp4396;"LABECOMK ""NEW""

LABEFIX \square *<string>*

Modifies the label of user defined test fixture. (**LABEL FIXTURE** under **Meas** **FIXTURE** \square ; Impedance analyzer only.)

Parameter	Description
<i><string></i>	Up to ten characters.

- Query Response
<string> <new line> <END>
- Equivalent SCPI Command
:SYSTem:FIXTure:LABel \square *<string>*
- Example
OUTPUT @Hp4396;"LABEFIX ""NEW""

LABELIMP{A|B|C}□<string>

Defines the label for the first class, second class, or the third class required for an impedance measurement calibration. (Impedance analyzer only) (LABEL CLASS under **Cal**); Impedance analyzer only.)

Parameter	Description
<string>	Up to ten characters.

- Equivalent SCPI Command

LABELIMPA□<string> :SENSe:CORRection:CKIT:CLASs13:LABeL□<string>

LABELIMPB□<string> :SENSe:CORRection:CKIT:CLASs14:LABeL□<string>

LABELIMPC□<string> :SENSe:CORRection:CKIT:CLASs15:LABeL□<string>

LABEFWD{T|M}□<string>

Defines the label for the forward transmission (THRU) or the forward match (THRU) calibration. (Network analyzer only) (LABEL: FWD. TRANS., FWD. MATCH under **Cal**); No query)

Parameter	Description
<string>	Up to ten characters.

- Equivalent SCPI Command

LABEFWDT□<string> :SENSe:CORRection:CKIT:CLASs7:LABeL□<string>

LABEFWDM□<string> :SENSe:CORRection:CKIT:CLASs9:LABeL□<string>

LABERES{P|I}□<string>

Defines the label for the response, or the response and isolation calibration. (Network analyzer only) (RESPONSE, RESPONSE & ISOL'N under **Cal**); No query)

Parameter	Description
<string>	Up to ten characters.

- Equivalent SCPI Command

LABERESP□<string> :SENSe:CORRection:CKIT:CLASs11:LABeL□<string>

LABERESI□<string> :SENSe:CORRection:CKIT:CLASs12:LABeL□<string>

- Example

```
OUTPUT @Hp4396;"LABERESP ""RESPONSE"""
```

```
OUTPUT @Hp4396;":SENS:CORR:CKIT:CLAS11:LAB ""RESPONSE"""
```

LABERES{P|I} <string>

LABEREV{T|M} <string>

Defines the label for reverse transmission (THRU) or the reverse match (THRU) calibration. (Network analyzer only) (REV.TRANS., REV.MATCH under **Cal**); No query

Parameter	Description
<string>	Up to ten characters.

■ Equivalent SCPI Command

LABEREVT <string> :SENSe:CORRection:CKIT:CLASs8:LABel <string>

LABEREVM <string> :SENSe:CORRection:CKIT:CLASs10:LABel <string>

LABES11{A|B|C} <string>

Defines the label for the first class, the second class, or the third class required for an S₁₁ 1-port calibration. (Network analyzer only) (LABEL: S11A, S11B, S11C under **Cal**); No query

Parameter	Description
<string>	Up to ten characters.

■ Equivalent SCPI Command

LABES11A <string> :SENSe:CORRection:CKIT:CLASs1:LABel <string>

LABES11B <string> :SENSe:CORRection:CKIT:CLASs2:LABel <string>

LABES11C <string> :SENSe:CORRection:CKIT:CLASs3:LABel <string>

LABES22{A|B|C} <string>

Defines the label for the first class, the second class, or the third class required for an S₂₂ 1-port calibration. (Network analyzer only) (LABEL: S22A, S22B, S22C under **Cal**); No query

Parameter	Description
<string>	Up to ten characters.

■ Equivalent SCPI Command

LABES22A <string> :SENSe:CORRection:CKIT:CLASs4:LABel <string>

LABES22B <string> :SENSe:CORRection:CKIT:CLASs5:LABel <string>

LABES22C <string> :SENSe:CORRection:CKIT:CLASs6:LABel <string>

■ Example

OUTPUT @Hp4396;"LABES22A ""OPENS""

OUTPUT @Hp4396;":SENS:CORR:CKIT:CLAS4:LAB ""OPENS""

LABK□<string>

Defines a label for a new calibration kit. (Network analyzer only) (**LABEL KIT** under **Cal**); No query)

Parameter	Description
<string>	Up to eight characters.

- Equivalent SCPI Command

```
:SENSe:CORRection:CKIT:LABel□<string>
```

- Example

```
OUTPUT @Hp4396;"LABK ""7mm""
```

```
OUTPUT @Hp4396;":SENS:CORR:CKIT:LAB ""7mm""
```

LABS□<string>

Defines a label for the standard. (Network analyzer only) (**LABEL STD** under **Cal**); No query)

Parameter	Description
<string>	Up to ten characters.

- Equivalent SCPI Command

```
:SENSe:CORRection:CKIT:STANdard:LABel□<string>
```

- Example

```
OUTPUT @Hp4396;"LABS ""SHORT""
```

```
OUTPUT @Hp4396;":SENS:CORR:CKIT:STAN:LAB ""SHORT""
```

LIMCLEL

Clears all segments in the limit line. (**CLEAR LIST YES** under **System**); No query)

- Equivalent SCPI Command

```
:CALCulate:LIMit:CLEar
```

LIMD□<numeric>

Sets the limits an equal amount above and below a specified middle value, instead of setting upper and lower limits separately. (**DELTA LIMITS** under **System**)

Parameter	Range	Unit
<numeric>	0 to 500000	

LIMD□<numeric>

- Query Response

{numeric} <new line><END>

- Equivalent SCPI Command

:CALCulate:LIMit:SEGment:DELta□<numeric>

LIMEDONE

Completes editing the limit table. (DONE under System); No query)

- Equivalent SCPI Command

:CALCulate:LIMit:SAVE

LIMIAMPO□<numeric>

Adds or subtracts an offset in amplitude value. (AMPLITUDE OFFSET under System)

Parameter	Range	Unit
<numeric>	-500000 to 500000	

- Query Response

{numeric} <new line><END>

- Equivalent SCPI Command

:CALCulate:LIMit:OFFSet□<numeric>

LIMILINE□{OFF|ON|0|1}

Sets limit lines ON or OFF. (LIMIT LINE ON off under System)

Parameter	Description
OFF or 0	Limit lines OFF
ON or 1	Limit lines ON

- Query Response

{0|1} <new line><END>

- Equivalent SCPI Command

:CALCulate:LIMit:LINE□{OFF|ON|0|1}

- Example

OUTPUT @Hp4396;"LIMILINE ON"

LIMIPRMO<numeric>

Adds or subtracts an offset from the sweep parameter value. (**SWP PARAM OFFSET** under **System**)

Parameter	Range	Unit
<numeric>	-1.82×10^9 (-1.82 G) to 1.82×10^9 (1.82 G) -70 to 70	Hz (frequency) dB (power)

■ Query Response

{numeric} <new line><END>

■ Equivalent SCPI Command

:CALCulate:LIMit:CONTRol:OFFSet<numeric>

LIMITEST{OFF|ON|0|1}

Sets the limit testing ON or OFF. (**LIMIT TEST ON off** under **System**)

Parameter	Description
OFF or 0	Limit testing OFF
ON or 1	Limit testing ON

■ Query Response

{numeric} <new line><END>

■ Equivalent SCPI Command

:CALCulate:LIMit:STATe{OFF|ON|0|1}

LIML<numeric>

Sets the lower limit value for the segment. (**LOWER LIMIT** under **System**)

Parameter	Range	Unit
<value>	-500000 to 500000	

■ Query Response

{numeric} <new line><END>

■ Equivalent SCPI Command

:CALCulate:LIMit:SEGment:LOWer<numeric>

LIML \square *<numeric>*

LIMM \square *<numeric>*

Sets the midpoint for delta limits. (**MIDDLE VALUE** under **System**)

Parameter	Range	Unit
<i><value></i>	-500000 to 500000	

■ Query Response

{numeric} \langle new line \rangle \langle END \rangle

■ Equivalent SCPI Command

:CALCulate:LIMit:SEGment:MIDDLE \square *<numeric>*

LIMPRM \square *<numeric>* [**HZ**|**KHZ**|**MAHZ**|**GHZ**|**DBM**]

Sets the starting sweep parameter value of a segment, using entry block controls. (**SWP PARAM** under **System**)

Parameter	Range	Unit
<i><numeric></i>	100000 (= 100 k) to 1.82×10^9 (= 1.82 G) -70 to 20	Hz (frequency) dBm (power)

■ Query Response

{numeric} \langle new line \rangle \langle END \rangle

■ Equivalent SCPI Command

:CALCulate:LIMit:SEGment:CONTROL[:DATA] \square *<numeric>*

LIMSADD

Adds a new segment to the end of the limit list. (**ADD** under **System**); No query)

■ Equivalent SCPI Command

:CALCulate:LIMit:SEGment:ADD

LIMSDEL

Deletes a limit testing segment. (**DELETE** under **System**); No query)

■ Equivalent SCPI Command

:CALCulate:LIMit:SEGment:DELeTe

LIMSDON

Terminates a limit segment definition. (**DONE** under **System**); No query)

■ Equivalent SCPI Command

:CALCulate:LIMit:SEGment:SAVE

LIMSEDI[<numeric>]

Specifies which limit segment in the table to edit. When you want to define or modify the values of the specified segment, you do not have to enter <numeric> (the segment number). (**SEGMENT**, **EDIT** under **System**)

Parameter	Description
<numeric>	Segment number, 1 to 18.

■ Query Response

```
{numeric} <new line><^END>
```

■ Equivalent SCPI Command

```
LIMSEDI<numeric> :CALCulate:LIMit:SEGment<numeric>  
(SEGMENT)
```

```
LIMSEDI[<numeric>] :CALCulate:LIMit:SEGment:EDIT<numeric> (No query)  
(EDIT)
```

LIMU[<numeric>]

Sets the upper limit value for a limit testing segment. (**UPPER LIMIT** under **System**)

Parameter	Range	Unit
<numeric>	-500000 to 500000	

■ Query Response

```
{numeric} <new line><^END>
```

■ Equivalent SCPI Command

```
:CALCulate:LIMit:SEGment:UPPer<numeric>
```

LINTDATA{0-7}

Sets the line type of the trace data for plotting. (**LINE TYPE DATA** under **Copy**; No query)

■ Equivalent SCPI Command

```
:HCOPy:ITEM:TRACe1:LTYPeLSTYLe{0-7}
```

■ Example

```
OUTPUT @Hp4396;"LINTDATA 7"
```

```
OUTPUT @Hp4396;":HCOP:ITEM:TRAC1:LTYP STYL7"
```

LINTDATA{0-7}

LINTMEMO{0-7}

Sets the line type of the memory trace for plotting. (**LINE TYPE MEMORY** under **COPY**); No query)

■ Equivalent SCPI Command

:HCOPY:ITEM:TRACe2:LTYPeLSTYLE{0-7}

■ Example

```
OUTPUT @Hp4396;"LINTMEMO 7"
```

```
OUTPUT @Hp4396;":HCOP:ITEM:TRAC2:LTYP STYL7"
```

LMAX?{<numeric>}

Outputs the *n*th peak value from the left of the analysis range. See "LMAX?" in Appendix I. (Instrument BASIC EXECUTE executable; No equivalent SCPI command; Network and spectrum analyzer only)

Parameter	Range	Unit
<numeric>	1 to 801	

■ Query Response

Parameter	Description
<numeric>	Complex number (Data format: real, imaginary)

LMIN?{<numeric>}

Outputs the *n*th negative peak value from the left of the analysis range. See "LMIN?" in Appendix I. (Instrument BASIC EXECUTE executable; No equivalent SCPI command; Network and spectrum analyzer only)

Parameter	Range	Unit
<numeric>	1 to 801	

■ Query Response

Parameter	Description
<numeric>	Complex number (Data format: real, imaginary)

LISV

Displays a tabular listing of all the measured data points and their current values. (**LIST VALUES** under **COPY**); No query)

■ Equivalent SCPI Command

```
:DISPlay[:WINDow]:TEXT1:PAGEL1
```

```
:DISPlay[:WINDow]:TEXT1:STATeL{ON|1}
```

LVCDT {<numeric>} [DB]

Sets the level cal data (adds an offset value to the measured value). (Spectrum analyzer only)
(LVL CAL DATA under Cal)

Parameter	Range	Unit
<numeric>	-10 to 10	dB

■ Query Response

{numeric} <new line><END>

■ Equivalent SCPI Command

:SENSe:CORRection:OFFSet[:MAGNitude]{<numeric>}

LVL CAL

Measures the CAL OUT signal (20 MHz, -20 dBm) at the input selected by the MEAS command (automatically sets the level cal data). After executing this function, the instrument state is returned to the state that existed before executing this function. (Spectrum analyzer only)
(EXECUTE LVL CAL under Cal; No query)

■ Equivalent SCPI Command

:CALibration:AUTO{ONCE}

MATH {DATA|DDVM|DMNM|DPLM}

Sets the trace math operation. (DATA MATH: DATA, DATA-MEM, DATA+MEM, DATA/MEM under DATA MATH [] under Display)

Parameter	Description
DATA	Turns OFF all data math functions.
DMNM	Subtracts the memory from the data.
DPLM	Adds the memory to the data.
DDVM	Divides the data by the memory.

■ Query Response

{DATA|DMNM|DPLM|DDVM} <new line><END>

■ Equivalent SCPI Command

MATH{DATA} :CALCulate:MATH2[:EXPRession]:NAME{OFF
MATH{DMNM} :CALCulate:MATH2[:EXPRession]:NAME{SUB
MATH{DPLM} :CALCulate:MATH2[:EXPRession]:NAME{ADD
MATH{DDVM} :CALCulate:MATH2[:EXPRession]:NAME{DIV

■ Example

OUTPUT @Hp4396;"MATH DATA"

OUTPUT @Hp4396;":CALC:MATH2:NAME OFF"

MATH \square {DATA|DDVM|DMNM|DPLM}

MAXMLEV \square <numeric> [DBM]

Sets the maximum mixer level. (Spectrum analyzer only) (MAX MIXER LEVEL under **Scale Ref**)

Parameter	Range	Unit
<numeric>	-100 to -10	dBm

■ Query Response

{numeric} <new line><END>

■ Equivalent SCPI Command

:SENSe:POWer:AC:RANGe[:UPPer] \square <numeric>

MEAS \square <parameter>

Selects the parameters or inputs to be measured. (NETWORK: A/R, B/R, R, A, B, Ref1: FWD S11 [A/R], Trans:FWD S21 [B/R], Trans:REV S12 [A/R], Ref1: REV S22 [B/R], SPECTRUM: S, R, A, B, IMPEDANCE: MAG(|Z|), PHASE(θ_Z), RESIST(R), REACT(X), ADMITTNCE:MAG(|Y|), PHASE(θ_Y), CONDUCT(G), SUSCEPT(B), REFL.COEF:MAX(| Γ |), PHASE(θ_Γ)), REAL(Γ_X), IMAG(Γ_Y), CAPCITNCE:PRL(Cp), SER(Cs), INDUCTNCE:PRL(Lp) SER(Ls), RESISTNCE:PRL(Rp), SER(Rs), D FACTOR(D), Q FACTOR(Q) under **Meas**)

Parameter	Description
AR	A/R measurement (Network analyzer only)
BR	B/R measurement (Network analyzer only)
R	R measurement (Both Network and Spectrum analyzers)
A	A measurement (Both Network and Spectrum analyzers)
B	B measurement (Both Network and Spectrum analyzers)
S11	S11 measurement (Network analyzer only)
S12	S12 measurement (Network analyzer only)
S21	S21 measurement (Network analyzer only)
S22	S22 measurement (Network analyzer only)
S	S measurement (Spectrum analyzer only)
IMAG	Z measurement (Impedance analyzer only)
IPH	θ_z (Impedance analyzer only)
IRE	R (Impedance analyzer only)
IIM	X (Impedance analyzer only)
AMAG	Y (Impedance analyzer only)
APH	θ_y (Impedance analyzer only)
ARE	G (Impedance analyzer only)
AIM	B (Impedance analyzer only)
RCM	Γ (Impedance analyzer only)
RCPH	θ_{Γ} (Impedance analyzer only)
RCR	Γ_x (Impedance analyzer only)
RCIM	Γ_y (Impedance analyzer only)
CP	Parallel Capacitance, C_p (Impedance analyzer only)
CS	Series Capacitance, C_s (Impedance analyzer only)
LP	Parallel Inductance, L_p (Impedance analyzer only)
LS	Series Inductance, L_s (Impedance analyzer only)
D	Disipation Factor, D (Impedance analyzer only)
Q	Quality Factor, Q (Impedance analyzer only)
RP	Parallel Resistance, R_p (Impedance analyzer only)
RS	Series Resistance, R_s (Impedance analyzer only)

■ Query Response

```
{AR|RB|R|A|B|S11|S12|S21|S22|S|IMAG|IPH|IRE|IIM|AMAG|APH|ARE|AIM|RCM|RCPH|
RCM|RCPH|RCR|RCIM|CP|CS|LP|LS|D|Q|RP|RS} <new line><END>
```

■ Equivalent SCPI Command

```
MEAS $\downarrow$ AR :SENSe:FUNCTion $\downarrow$ "POWER:RATio $\downarrow$ 3,2"
MEAS $\downarrow$ BR :SENSe:FUNCTion $\downarrow$ "POWER:RATio $\downarrow$ 4,2"
MEAS $\downarrow$ R :SENSe:FUNCTion $\downarrow$ "POWER $\downarrow$ 2"
MEAS $\downarrow$ A :SENSe:FUNCTion $\downarrow$ "POWER $\downarrow$ 3"
MEAS $\downarrow$ B :SENSe:FUNCTion $\downarrow$ "POWER $\downarrow$ 4"
MEAS $\downarrow$ S11 :SENSe:FUNCTion $\downarrow$ "POWER:S11"
MEAS $\downarrow$ S21 :SENSe:FUNCTion $\downarrow$ "POWER:S21"
MEAS $\downarrow$ S12 :SENSe:FUNCTion $\downarrow$ "POWER:S12"
MEAS $\downarrow$ S22 :SENSe:FUNCTion $\downarrow$ "POWER:S22"
MEAS $\downarrow$ S :SENSe:FUNCTion $\downarrow$ "POWER $\downarrow$ 1"
MEAS $\downarrow$ IMAG CALCulate:MATH1[:EXPRession]:NAME IMPedance
CALCulate:FORMat MLINear
MEAS $\downarrow$ IPH CALCulate:MATH1[:EXPRession]:NAME IMPedance
CALCulate:FORMat PHASe
```

MEASU<parameter>

MEASUIRE	CALCulate:MATH1[:EXPRession]:NAME IMPedance CALCulate:FORMat REAL
MEASUIIM	CALCulate:MATH1[:EXPRession]:NAME IMPedance CALCulate:FORMat IMAGinary
MEASUIAMAG	CALCulate:MATH1[:EXPRession]:NAME ADMittance CALCulate:FORMat MLINear
MEASUIAPHS	CALCulate:MATH1[:EXPRession]:NAME ADMittance CALCulate:FORMat PHASe
MEASUIARE	CALCulate:MATH1[:EXPRession]:NAME ADMittance CALCulate:FORMat REAL
MEASUIAIM	CALCulate:MATH1[:EXPRession]:NAME ADMittance CALC:FORMat IMAGinary
MEASUIRCM	CALCulate:MATH1[:EXPRession]:NAME OFF CALCulate:FORMat MLINear
MEASUIRCPH	CALCulate:MATH1[:EXPRession]:NAME OFF CALCulate:FORMat PHASe
MEASUIRCR	CALCulate:MATH1[:EXPRession]:NAME OFF CALCulate:FORMat REAL
MEASUIRCIM	CALCulate:MATH1[:EXPRession]:NAME OFF CALCulate:FORMat IMAGinary
MEASUICP	CALCulate:MATH1[:EXPRession]:NAME IMPedance CALCulate:FORMat CP
MEASUICS	CALCulate:MATH1[:EXPRession]:NAME IMPedance CALCulate:FORMat CS
MEASUILP	CALCulate:MATH1[:EXPRession]:NAME IMPedance CALCulate:FORMat LP
MEASUILS	CALCulate:MATH1[:EXPRession]:NAME IMPedance CALCulate:FORMat LS
MEASUID	CALCulate:MATH1[:EXPRession]:NAME IMPedance CALCulate:FORMat D
MEASUIQ	CALCulate:MATH1[:EXPRession]:NAME IMPedance CALCulate:FORMat Q
MEASUIRP	CALCulate:MATH1[:EXPRession]:NAME IMPedance CALCulate:FORMat RP
MEASUIRS	CALCulate:MATH1[:EXPRession]:NAME IMPedance CALCulate:FORMat RS

■ Example

```

OUTPUT @Hp4396;"MEAS AR"
OUTPUT @Hp4396;"MEAS?"
ENTER @Hp4396;A$

OUTPUT @Hp4396;":SENS:FUNC ""POW:RAT 3,2""
OUTPUT @Hp4396;":SENS:FUNC?"
ENTER @Hp4396;A$

```

MEASSTAT $\{OFF|ON|0|1\}$

Calculates the mean, standard deviation, and peak-to-peak values in the portion of the displayed trace that is in the search range. (STATICS ON off under **Utility**)

Parameter	Description
OFF or 0	Does not display the statistical values
ON or 1	Displays the statistical values

- Query Response

{0|1} <new line><END>

- Equivalent SCPI Command

:CALCulate:EVALuate:MStatistics[:STATe] $\{OFF|ON|0|1\}$

MKR $\{OFF|ON|0|1\}$

Sets the marker to active (ON) or inactive (OFF). When the MKR is turned off, the marker, sub-marker, and Δ marker are tuned to be off. (**MKR**)

Parameter	Description
OFF or 0	Turns off the marker function.
ON or 1	Turns on the marker function.

- Query Response

{0|1} <new line><END>

- Equivalent SCPI Command

:DISPlay[:WINDow]:TRACe{[1]|2}:MARKer[1]:ALL:STATe $\{OFF|ON|0|1\}$

(TRACe[1] for the data trace; TRACe2 for the memory trace.)

MKRAMPO

Moves the limits so that they are centered an equal amount above and below the marker at the sweep parameter value. (MAKER→AMP.OFS. under **System**); No query)

- Equivalent SCPI Command

:CALCulate:LIMit:OFFSetLIMARKer

MKRAUV?

Outputs the auxiliary amplitude value (value 2) of the measurement value at the marker position. See "Marker Readout" in Appendix H for the auxiliary amplitude value of each display format. (Query only)

- Query Response

{*numeric*} <new line><END>

- Equivalent SCPI Command

:CALCulate:EVALuate:Y[1]:VALue2?

MKRAUV?

MKRCENT

Sets the sweep parameter center value of the destination channel to the sweep parameter value of the marker and centers the new span about that value. (MKR→CENTER under Marker→); No query)

■ Equivalent SCPI Command

:SENSe:FREQuency:CENTer␣MARKer (frequency) or
:SOURce:POWer:CENTer␣MARKer (power)

MKRCONT␣{OFF|ON|0|1}

Sets the continuous or discontinuous marker mode. (Network and impedance analyzer only) (MKR [] under Marker)

Parameter	Description
OFF or 0	Discontinuous marker mode.
ON or 1	Continuous marker mode.

■ Query Response

{0|1} <new line><END>

■ Equivalent SCPI Command

:CALCulate:EVALuate:INTerpolate␣{OFF|ON|0|1}

MKRCOUP␣{OFF|ON|0|1}

Sets the coupled or uncoupled marker mode. (MKR [] under Marker)

Parameter	Description
OFF or 0	Uncoupled marker mode
ON or 1	Coupled marker mode

■ Query Response

{0|1} <new line><END>

■ Equivalent SCPI Command

:CALCulate:EVALuate:COUple␣{OFF|ON|0|1}

MKRCSTE

Sets the CENTER step size to the marker's sweep parameter value. (MKR→CNTR STEP under Center); No query)

■ Equivalent SCPI Command

:SENSe:FREQuency:CENTter:STEP[:INCRement]␣MARKer

MKRDCENT

Sets the sweep parameter center value of the destination channel to the difference value between the marker and the Δ marker values. (MKRA→CENTER under **Center** and **Marker→**); No query)

- Equivalent SCPI Command

:SENSe:FREQuency:CENTer Δ DMARker (frequency) or
:SOURce:POWer:CENTer Δ DMARker (power)

MKRDCSTE

Sets the CENTER step size to the difference between the marker and Δ marker values. (MKRA→CNTR STEP under **Center**); No query)

- Equivalent SCPI Command

:SENSe:FREQuency:CENTer:STEP[:INCRement] Δ DMARker

MKRDELA

Sets the group delay at the marker point of a fixed frequency aperture, 20% of the span, to the electrical delay to balance the phase of the DUT. (Network analyzer only) (MKR→DELAY under **Scale Ref**); No query)

- Equivalent SCPI Command

:SENSe:CORRection:EDELay2 Δ MARKer

MKRDSPAN

Sets the SPAN of the destination channel to the difference between the marker and the Δ marker values. (MKRA→CENTER under **Span** or **Marker→**); No query)

- Equivalent SCPI Command

:SENSe:FREQuency:SPAN Δ DMARker (frequency) or
:SOURce:POWer:SPAN Δ DMARker (power)

MKRL{OFF|ON|0|1}

Sets the maker list function ON or OFF. (MKR LIST ON off under **Utility**)

Parameter	Description
OFF or 0	Marker list function OFF
ON or 1	Marker list function ON

- Query Response

{0|1} <new line><END>

- Equivalent SCPI Command

:DISPlay[:WINDow]:TEXT16:STATeL{OFF|ON|0|1}

MKRL {OFF|ON|0|1}

MKRMIDD

Sets the midpoint the LIMD command using the marker to set the middle amplitude value of a limit segment. (MKR→MIDDLE under **System**); No query)

- Equivalent SCPI Command

:CALCulate:LIMit:SEGment:MIDDLELMARkeR

MKRNOI {OFF|ON|0|1}

Sets the noise format of the marker ON or OFF. This marker reads out the average noise level at the marker position (referenced to a 1 Hz noise power bandwidth). (Spectrum analyzer only) (NOISE FORM ON off under **Utility**)

- Query Response

{0|1} <new line><END>

- Equivalent SCPI Command

:CALCulate:EVALuate:NOISe[:STATe] {OFF|ON|0|1}

MKRO {DATA|MEMO}

Sets a trace from data or memory to be applied for the marker values. (MKR ON [] under **Marker**)

Parameter	Description
DATA	DATA TRACE
MEMO	MEMORY TRACE

- Query Response

{DATA|MEMO} <new line><END>

- Equivalent SCPI Command

MKRO DATA :CALCulate:EVALuate:ON "DTR"

MKRO MEMO :CALCulate:EVALuate:ON "MTR"

- Example

OUTPUT @Hp4396;"MKRO DATA"

MKROFS

Sets the marker's amplitude value into the offset value. (MKR→OFFSET under **Display**); No query)

- Equivalent SCPI Command

:DATA[:DATA] OFFS,MARKer

MKRP \square *<numeric>*

Moves the marker to the specified data point number.

Parameter	Description
<i><numeric></i>	1 to Number of Points

- Query Response

{*numeric*} <new line><END>

- Equivalent SCPI Command

:CALCulate:EVALuate:Y[1]:XPOSITION:POINT \square *<numeric>*

MKRPKD

Sets the peak delta value to the smaller value of the difference of amplitude values between the present marker position and both side display points of the marker. (Network and impedance analyzer only) (MKR \rightarrow PEAK DELTA under **Search**); No query)

- Equivalent SCPI Command

:CALCulate:EVALuate:PEAK:EXCursion \square DMARKer

MKRPRM \square *<numeric>* [HZ|KHZ|MAHZ|GHZ|DBM]

Sets the marker at the point of the specified sweep parameter, when the marker is ON.

Parameter	Range	Unit
<i><numeric></i>	start value to stop value	Hz (frequency) dBm (power)

- Query Response

{*numeric*} <new line><END>

- Equivalent SCPI Command

:CALCulate:EVALuate:Y[1]:XPOSITION \square *<numeric>*

MKRREF

Makes the reference value of the destination channel equal to the marker's absolute value (regardless of the Δ marker value). (MKR \rightarrow REFERENCE under **Scale Ref** and **Marker \rightarrow**); No query)

- Equivalent SCPI Command

:DISPlay[:WINDow]:TRACe{[1]|2}:Y[:SCALE]:RLEVEL \square MARKer

(TRACe[1] for the data trace; TRACe2 for the memory trace.)

MKRREF

MKRSTAR

Sets the sweep parameter start value of the destination channel to the sweep parameter value of the marker. (`SEGMENT: MKR→START` under `Sweep`, or `MKR→START` under `Marker→`; No query)

■ Equivalent SCPI Command

`SEGMENT: MKR→START` under `Sweep` :SENSe:LIST:SEGment:FREQuency:STARtLMARKer
`MKR→START` under `Marker→` :SENSe:FREQuency:STARtLMARKer (frequency) or
:SOURce:POWer:STARtLMARKer (power)

MKRSTOP

Sets the sweep parameter stop value of the destination channel to the sweep parameter value of the marker. (`MKR→STOP` under `Sweep`, or `MKR→STOP` under `Marker→`; No query)

■ Equivalent SCPI Command

`MKR→STOP` under `Sweep` :SENSe:LIST:SEGment:FREQuency:STOPLMARKer
`MKR→STOP` under `Marker→` :SENSe:FREQuency:STOPLMARKer (frequency) or
:SOURce:POWer:STOPLMARKer (power)

MKRSWPRM

Sets the segment sweep parameter value to the present marker sweep parameter value. (`MKR→SWP PARAM` under `System`; No query)

■ Equivalent SCPI Command

:CALCulate:LIMit:SEGment:CONTrol[:DATA]LMARKer

MKRTHRE

Sets the threshold value to the amplitude value of the present marker position. (`MKR→THRESHOLD` under `Search`; No query)

■ Equivalent SCPI Command

:CALCulate:EVALuate:PEAK:THResholdLMARKer

MKRTIME {OFF|ON|0|1}

Sets the x-axis units to time, (the start point is zero and the stop point is the value of the sweep time). (MKR TIME ON off under **Utility**)

Parameter	Description
OFF or 0	Sets the x-axis to the sweep parameter
ON or 1	Sets the x-axis to time

- Query Response

{0|1} <new line><END>

- Equivalent SCPI Command

:DISPlay[:WINDow]:TRACe{[1]|2}:MARKer[1]:UNIT:TIME{OFF|ON|0|1}

- Example

```
OUTPUT @Hp4396;"MKRTIME ON"
```

MKRVAL?

Outputs the amplitude value of the measurement value at the marker position. See "Marker Readout" in Appendix H for the amplitude value of each display format. (Query only)

- Query Response

{*numeric*} <new line><END>

- Equivalent SCPI Command

:CALCulate:EVALuate:Y[1]:VALue1?

- Example

```
OUTPUT @Hp4396;"MKRVAL?"
ENTER @Hp4396;A
```

MKRZM

Sets the sweep parameter center value of the destination channel to the sweep parameter value of the marker, and changes the sweep parameter span value of the destination channel to "sweep parameter span × zooming aperture." (MKR ZOOM under **Marker**); No query)

- Equivalent SCPI Command

:SENSe:FREQuency:SPANLMZAPerture (frequency) or
:SOURce:POWer:SPANLMZAPerture (power)

MODII

Leads to the modify calibration kit menu, where a calibration kit can be user-modified. (MODIFY [] under **Cal**); No query)

- Equivalent SCPI Command

:SENSe:CORRection:CKIT:MODify

MODII

MODICOMK

Leads to the modify fixture compensation kit menu. (MODIFY [] under (Cal) COMPEN KIT [] ; No query; Impedance analyzer only.)

- Equivalent SCPI Command

:SENSe:CORRection2:CKIT:MODify

MODIFX

Leads to the modify user fixture menu. (MODIFY [] under (Meas) FIXTURE [] ; No query; Impedance analyzer only.)

- Equivalent SCPI Command

:SYSTem:FIXTure:MODify

MONDYEAR

Changes the displayed date to the "month:day:year" format. (DATE MODE: MonDayYear under (System))

- Query Response

{0|1} <new line><END>

Parameter	Description
0	"day:month:year" format
1	"month:day:year" format

- Equivalent SCPI Command

:SYSTem:DATE:MODELMNDY

NA

Selects the network analyzer as the analyzer type. (NETWORK ANALYZER under (Meas))

- Query Response

{0|1}<new line><END>

Parameter	Description
0	Network analyzer is not selected.
1	Network analyzer is selected.

- Equivalent SCPI Command

INSTRument:TYPELNA

- Example

```
OUTPUT @Hp4396;"NA?"
```

```
ENTER @Hp4396;Na
```

```
If Na THEN PRINT "Network Analyzer Mode is selected."
```

NEXP

Displays the next page of information in a tabular listing. (NEXT PAGE under **Copy**); No query)

■ Equivalent SCPI Command

```
:DISPlay[:WINDow]:TEXT{1-17}:PAGEUP
```

Parameter	Description
1	List Value
2	Operation Parameter
3	Cal Class
4 to 11	Cal Standard No. 1 to No. 8
12	Start and Stop
13	Center and Span (List)
14	Upper and Lower
15	Middle and Delta (Limit Test)
16	Marker List
17	Title

NEXPK?

Outputs the maximum peak value and its stimulus next to the peak last found by the PEAK?, or NEXPK? commands. For more information, see "NEXPK?" in Appendix I. (Instrument BASIC EXECUTE executable; No equivalent SCPI command; Query only; Network and spectrum analyzer only)

NUMGL<numeric>

Triggers a user-specified number of sweeps and returns to the HOLD mode. (NUMBER OF GROUPS under **Trigger**); No query)

Parameter	Description
<numeric>	Greater than 0 (if <numeric> is 0 or less than 0, it is set to 1.)

■ Equivalent SCPI Command

```
:INITiate:CONTinuous{OFF|0}
:SENSe:SWEep:COUNT<numeric>
:INITiate[:IMMediate]
```

■ Example

```
OUTPUT @Hp4396;"NUMG 10"
OUTPUT @Hp4396;":INIT:CONT OFF"
OUTPUT @Hp4396;":SENS:SWE:COUN 10"
OUTPUT @Hp4396;":INIT"
```

NUMLMAX?

Outputs the number of peaks within the analysis range. See "NUMLMAX?" in Appendix I. (Instrument BASIC EXECUTE executable; No equivalent SCPI command; Network and spectrum analyzer only)

■ Query Response

<numeric><new line><END>

NUMLMIN?

Outputs the number of negative peaks within the analysis range. See "NUMLMIN?" in Appendix I. (Instrument BASIC EXECUTE executable; No equivalent SCPI command; Network and spectrum analyzer only)

■ Query Response

<numeric><new line><END>

OFSD□<numeric>[S]

Specifies the one-way electrical delay from the measurement (reference) plane to the standard. (Network and impedance analyzer only) (OFFSET DELAY under **Cal**); No query)

Parameter	Range	Unit
<numeric>	-10 to 10	s

■ Equivalent SCPI Command

:SENSe:CORRection:CKIT:STANdard:ODELay□<numeric>

OFSL□<value>

Specifies energy loss, due to skin effect, along a one-way length of coaxial cable offset. (Network and impedance analyzer only) (OFFSET LOSS under **Cal**); No query)

Parameter	Range	Unit
<value>	0 to 1×10^{19}	Ω/s

■ Equivalent SCPI Command

:SENSe:CORRection:CKIT:STANdard:OLOSs□<numeric>

OFSZ \square *<numeric>* [OHM]

Specifies the characteristic impedance of the coaxial cable offset. (Network and impedance analyzer only) (OFFSET Z Ω under **Cal**); No query

Parameter	Range	Unit
<i><numeric></i>	0.1 to 5000000 (= 500 k)	Ω

- Equivalent SCPI Command

:SENSe:CORRection:CKIT:STANdard:OCIMpedance \square *<numeric>*

OMI

Omits correction for isolation of a 2-port calibration. (Network analyzer only) (OMIT ISOLATION under **Cal**); No query

- Equivalent SCPI Command

:SENSe:CORRection:COLLect[:ACQuire] \square OMI

OPEP

Provides a tabular listing on the display of the key parameters for both channels. (OPERATING PARAMETERS under **Copy**); No query

- Equivalent SCPI Command

:DISPlay[:WINDow]:TEXT2:PAGEL1
:DISPlay[:WINDow]:TEXT2:STATel{ON|1}

OSE \square *<numeric>*

Enables the operational status register.

Parameter	Description
<i><numeric></i>	Decimal expression of the contents of the register, 0 to 65535 (= 2 ¹⁶ - 1)

- Query Response

{*numeric*} <new line><END>

- Equivalent SCPI Command

:STATus:OPERation:ENABLe \square *<numeric>*

OSER?

Outputs the current value in the event register of an operational status register. (Query only)

- Query Response

{*numeric*} <new line><END>

- Equivalent SCPI Command

:STATus:OPERation[:EVENT]?

OSER?

OSNT□<numeric>

Sets the negative transition filter of an operational status register. For details, refer to Appendix D.

Parameter	Description
<numeric>	Decimal expression of the contents of the register, 0 to 65535 ($=2^{16}-1$)

■ Query Response

{numeric} <new line><END>

■ Equivalent SCPI Command

:STATus:OPERation:NTRansition□<numeric>

OSPT□<numeric>

Sets the positive transition filter of an operational status register. For details, refer to Appendix D.

Parameter	Description
<numeric>	Decimal expression of the contents of the register, 0 to 65535 ($=2^{16}-1$)

■ Query Response

{numeric} <new line><END>

■ Equivalent SCPI Command

:STATus:OPERation:PTRansition□<numeric>

OSR?

Outputs the operational status register value. (Query only)

■ Query Response

{numeric} <new line><END>

■ Equivalent SCPI Command

:STATus:OPERation:CONDition?

OUT8IO□<numeric>

Outputs the data to the 8-bit parallel output port. (No query)

Parameter	Description
<numeric>	0 to 255

■ Equivalent SCPI Command

:SYSTem:COMMunicate:PARAllel:TRANsmit:DATA□<numeric>

OUTPCALC{1-12}?

Outputs the active calibration set array of the active channel. Refer to Appendix F for the calibration set array. (Network and impedance analyzer only) (Query only)

- Query Response

{numeric (1)} {numeric (2)} ... {numeric (n)} <new line><END> (n is the number of points.)

numeric is a complex number (data format: real, imaginary).

- Equivalent SCPI Command

:DATA[:DATA]?LCCO{1-12}

- Example

```
DIM A(1:201,1:2)      NOP: 201
OUTPUT 717;"OUTCALC1?"
ENTER 717;A(*)

DIM A(1:201,1:2)
OUTPUT 717;" :DATA? CCO1"
ENTER 717;A(*)
```

OUTPCALK?

Outputs the active calibration kit. (Network and impedance analyzer only) (Query only)

- Query Response

{block data (714 bytes of binary data)} <new line><END>

- Equivalent SCPI Command

:DATA[:DATA]?LCKIT

OUTPCERR?

Outputs ceramic resonator parameters. See "OUTPCERR?" in Appendix I for details, query response, and examples. (Instrument BASIC EXECUTE executable; No equivalent SCPI command; Query only; Network analyzer only)

OUTPCFIL?

Outputs ceramic filter parameters. See "OUTPCFIL?" in Appendix I for details, query response, and examples. (Instrument BASIC EXECUTE executable; No equivalent SCPI command; Query only; Network analyzer only)

OUTPCFIL?

OUTPCOMC{1|2|3}?

Outputs data of the fixture compensation arrays. See "INPUCOMC{1|2|3}␣<numeric>" for details about the fixture compensation arrays. (Impedance analyzer only)

■ Query Response

```
{numeric (1)} {numeric (2)} ... {numeric (n)} <new line><END>
```

(n is the number of points.)

numeric is a complex number. (data format: real, imaginary)

■ Equivalent SCPI Command

```
:DATA[:DATA]?␣CMP{1|2|3}
```

OUTPDATA?

Outputs the error corrected data. (Query only)

■ Query Response

```
{numeric (1)} {numeric (2)} ... {numeric (n)} <new line><END>
```

(n is the number of points.)

numeric is a complex number (data format: real, imaginary) for the Network analyzer, or a real number for the Spectrum analyzer.

■ Equivalent SCPI Command

```
:DATA[:DATA]?␣LDATA
```

■ Example

```
DIM A(1:201,1:2)           Network Analyzer, NOP: 201
OUTPUT 717;"OUTPDATA?"
ENTER 717;A(*)

DIM A(1:201,1:2)
OUTPUT 717;":DATA? DATA"
ENTER 717;A(*)
```

OUTPDATAP? \square *<numeric>*

Outputs the error corrected data at the specified point. (Query only)

Parameter	Description
<i><numeric></i>	1 to "number of points" (If <i><numeric></i> is 0 or less than 0, it is set to 1. If <i><numeric></i> is greater than "number of points," it is set to "number of points.")

- Query Response

{numeric (real)} *{numeric (imaginary)}* <new line><END> (Network analyzer)

{numeric (val)} <new line><END> (Spectrum analyzer)

- Equivalent SCPI Command

:DATA[:DATA]:VALue? \square DATA, *<numeric>*

- Example

```
OUTPUT 717;"OUTPDATAP? 1"
ENTER 717;A,B                               Network Analyzer
OUTPUT 717;":DATA:VAL? DATA,1"
ENTER 717;A,B
```

OUTPDMKR?

Outputs sweep parameter and measurement value at the Δ marker position. (Query only)

- Query Response

{numeric (val1)} *{numeric (val2)}* *{numeric (stimulus)}* <new line><END>

(Val1: Amplitude value, Val2: Auxiliary amplitude value. See "Marker Readout" in Appendix H.)

- Equivalent SCPI Command

:CALCulate:EVALuate:REFerence:DATA?

- Example

```
OUTPUT 717;"OUTPDMKR?"
ENTER 717;A,B,C
OUTPUT 717;":CALC:EVAL:REF:DATA?"
ENTER 717;A,B,C
```

OUTPDMKR?

OUTPDTRC?

Outputs DATA TRACE data. (Query only)

■ Query Response

{*numeric* (1:val1)} {*numeric* (1:val2)} {*numeric* (2:val1)} {*numeric* (2:val2)} ...
{*numeric* (n:val2)} {*numeric* (n:val2)} <new line><END> (Network analyzer)

{*numeric* (1)} {*numeric* (2)} ... {*numeric* (n)} <new line><END> (Spectrum analyzer)

(n is the number of points.) (Val1: Amplitude value, Val2: Auxiliary amplitude value. See "Marker Readout" in Appendix H.)

■ Equivalent SCPI Command

:TRACe[:DATA]?LDTR

■ Example

```
DIM A(1:201,1:2)           Network Analyzer, NOP: 201
OUTPUT 717;"OUTPDTRC?"
ENTER 717;A(*)

DIM A(1:201,1:2)
OUTPUT 717;":TRAC? DTR"
ENTER 717;A(*)
```

OUTPDTRCP?<numeric>

Outputs DATA TRACE data at the specified point. (Query only)

Parameter	Description
<numeric>	1 to "number of points" (If <numeric> is 0 or less than 0, it is set to 1. If <numeric> is greater than "number of points," it is set to "number of points.")

■ Query Response

{*numeric* (val1)} {*numeric* (val2)} <new line><END> (Network analyzer)

{*numeric* (val)} <new line><END> (Spectrum analyzer)

(Val1: Amplitude value, Val2: Auxiliary amplitude value. See "Marker Readout" in Appendix H.)

■ Equivalent SCPI Command

:TRACe[:DATA]:VALue?LDTR,<numeric>

■ Example

```
OUTPUT 717;"OUTPDTRCP? 1"
ENTER 717;A,B

OUTPUT 717;":TRAC:VAL? DTR,1"
ENTER 717;A,B
```

OUTPERRO?

Outputs the error message in the error queue.

- Query Response

{numeric (Error number)} *{string (Error message)}* <new line><END>

- Equivalent SCPI Command

:SYSTem:ERRor?

- Example

```
OUTPUT 717;"OUTPERRO?"
ENTER 717;A,A$

OUTPUT 717;":SYST:ERR?"
ENTER 717;A,A$
```

OUTPFAIP?

Outputs number of the failed point of the limit test. (Query only)

- Query Response

{numeric} <new line><END>

- Equivalent SCPI Command

:DATA:POINTs?LLFA

- Example

```
OUTPUT 717;"OUTPFAIP?"
ENTER 717;A

OUTPUT 717;":DATA:POIN? LFA"
ENTER 717;A
```

OUTPFILT?

Outputs filter parameters. See "OUTPFILT?" in Appendix I for details, query response, and examples. (Instrument BASIC EXECUTE executable; No equivalent SCPI command; Query only; Network analyzer only)

OUTPLIMF?

Outputs the limit test results only for the failed points. (Query only)

- Query Response

{numeric (stimulus 1)} *{0}* *{numeric (upper_limit 1)}* *{numeric (lower_limit 1)}*
{numeric (stimulus 2)} *{0}* *{numeric (upper_limit 2)}* *{numeric (lower_limit 2)}*
 ⋮
{numeric (stimulus n)} *{0}* *{numeric (upper_limit n)}* *{numeric (lower_limit n)}* <new
 line><END> (Form 4)

(n is the number of failed points.)

{0} <new line><END> (for no failed points.)

OUTPLIMF?

- Equivalent SCPI Command

:DATA[:DATA]?LLFA

- Example

```
DIM A(1:201,1:4)          NOP: 201
OUTPUT 717;"OUTPLIMF?"
ENTER 717 USING "%,K";A(*)

DIM A(1:201,1:4)
OUTPUT 717;":DATA? LFA"
ENTER 717 USING "%,K";A(*)
```

OUTPLIML?

Outputs the limit test results for each point. (Query only)

- Query Response

{*numeric (stimulus 1)*} {*numeric (result 1)*} {*numeric (upper_limit 1)*}
{*numeric (lower_limit 1)*}

{*numeric (stimulus 2)*} {*numeric (result 2)*} {*numeric (upper_limit 2)*}
{*numeric (lower_limit 2)*}

⋮

{*numeric (stimulus n)*} {*numeric (result n)*} {*numeric (upper_limit n)*}
{*numeric (lower_limit n)*} <new line><END> (Form 4)

(n is the number of points.) (*result* is 1 for pass, 0 for fail, or -1 for no test.)

- Equivalent SCPI Command

:DATA[:DATA]?LLIS

- Example

```
DIM A(1:201,1:4)          NOP: 201
OUTPUT 717;"OUTPLIML?"
ENTER 717;A(*)

DIM A(1:201,1:4)
OUTPUT 717;":DATA? LLIS"
ENTER 717;A(*)
```

OUTPLIMM?

Outputs the limit test result for the marker position. (Query only)

- Query Response

```
{numeric (stimulus)} {numeric (result)} {numeric (upper_limit)} {numeric (lower_limit)}
<new line><END>
```

(*result* is 1 for pass, 0 for fail, or -1 for no test)

- Equivalent SCPI Command

```
:DATA[:DATA]?LIMAR
```

- Example

```
OUTPUT 717;"OUTPLIMM?"
ENTER 717;A,B,C,D

OUTPUT 717;":DATA? LMAR"
ENTER 717;A,B,C,D
```

OUTPMAX?

Outputs maximum value within analysis range. See "OUTPMAX?" in Appendix I for details, query response, and examples. (Instrument BASIC EXECUTE executable; No equivalent SCPI command; Query only; Network and spectrum analyzer only)

OUTPMEAN?

Outputs mean value within analysis range. See "OUTPMEAN?" in Appendix I for details, query response, and examples. (Instrument BASIC EXECUTE executable; No equivalent SCPI command; Query only; Network and spectrum analyzer only)

OUTPMEMO?

Outputs the memory data from the active channel. (Query only)

- Query Response

```
{numeric (1)} {numeric (2)} ... {numeric (n)} <new line><END>
```

(*n* is the number of points.)

numeric is a complex number (data format: real, imaginary) for the Network analyzer, or a real number for the Spectrum analyzer.

- Equivalent SCPI Command

```
:DATA[:DATA]?LMEM
```

- Example

```
DIM A(1:201,1:2)           Network Analyzer, NOP: 201
OUTPUT 717;"OUTPMEMO?"
ENTER 717;A(*)

DIM A(1:201,1:2)
OUTPUT 717;":DATA? MEM"
ENTER 717;A(*)
```

OUTPMEMO?

OUTPMEMOP?□<numeric>

Outputs the memory data from the active channel at a specified point. (Query only)

Parameter	Description
<value>	1 to "number of points" (If <numeric> is 0 or less than 0, it is set to 1. If <numeric> is greater than "number of points," it is set to "number of points.")

■ Query Response

{real} {imaginary} <new line><END> (Network analyzer)

{numeric} <new line><END> (Spectrum analyzer)

■ Equivalent SCPI Command

:DATA[:DATA]:VALue?LMEM,<numeric>

OUTPMIN?

Outputs minimum value within analysis range. See "OUTPMIN?" in Appendix I for details, query response, and examples. (Instrument BASIC EXECUTE executable; No equivalent SCPI command; Query only; Network and spectrum analyzer only)

OUTPMINMAX?

Outputs maximum and minimum value within analysis range. See "OUTPMIN?" in Appendix I for details, query response, and examples. (Instrument BASIC EXECUTE executable; No equivalent SCPI command; Query only; Network and spectrum analyzer only)

OUTPMKR?

Outputs the sweep parameter and measurement values at the marker position. (Query only)

■ Query Response

{numeric (val1)} {numeric (val2)} {numeric (stimulus)} <new line><END>

(Val1: Amplitude value, Val2: Auxiliary amplitude value. See "Marker Readout" in Appendix H.)

■ Equivalent SCPI Command

:CALCulate:EVALuate:Y:DATA?

■ Example

```
OUTPUT 717;"OUTPMKR?"
ENTER 717;A,B,C

OUTPUT 717;":CALC:EVAL:Y:DATA?"
ENTER 717;A,B,C
```

OUTPMSTA?

Outputs the marker statistics. (STATISTICS ON off under **Utility**); Query only)

■ Query Response

```
{numeric (mean)} {numeric (standard deviation)} {numeric (peak to peak)}
<new line><END>
```

■ Equivalent SCPI Command

```
:CALCulate:EVALuate:MStatistics:DATA?
```

■ Example

```
OUTPUT 717;"OUTPMSTA?"
ENTER 717;A,B,C

OUTPUT 717;":CALC:EVAL:MST:DATA?"
ENTER 717;A,B,C
```

OUTPMTRC?

Outputs the MEMORY TRACE data. (Query only)

■ Query Response

```
{numeric (1:val1)} {numeric (1:val2)} {numeric (2:val1)} {numeric (2:val)} ...
{numeric (n:val1)} {numeric (n:val2)} <new line><END> (Network analyzer)
```

```
{numeric (1)} {numeric (2)} ... {numeric (n)} <new line><END> (Spectrum analyzer)
```

(n is the number of points.) (Val1: Amplitude value, Val2: Auxiliary amplitude value. See "Marker Readout" in Appendix H.)

■ Equivalent SCPI Command

```
:TRACe[:DATA]?LMTR
```

■ Example

```
DIM A(1:201,1:2)           Network Analyzer, NOP: 201
OUTPUT 717;"OUTPMTRC?"
ENTER 717;A(*)

DIM A(1:201,1:2)
OUTPUT 717;":TRAC? MTR"
ENTER 717;A(*)
```

OUTPMTRC?

OUTPMTRCP?<numeric>

Outputs the MEMORY TRACE data at the specified point. (Query only)

Parameter	Description
<numeric>	1 to "number of points" (If <numeric> is 0 or less than 0, it is set to 1. If <numeric> is greater than "number of points," it is set to "number of points.")

■ Query Response

{*numeric (val1)*} {*numeric (val2)*} <new line><END> (Network analyzer)

{*numeric (val)*} <new line><END> (Spectrum analyzer)

(Val1: Amplitude value, Val2: Auxiliary amplitude value. See "Marker Readout" in Appendix H.)

■ Equivalent SCPI Command

:TRACe[:DATA]:VALue?LMTR,<numeric>

■ Example

```
OUTPUT 717;"OUTPMTRCP? 1" Network Analyzer
ENTER 717;A,B
```

f

```
OUTPUT 717;":TRAC:VAL? MTR,1"
ENTER 717;A,B
```

OUTPMWID?

Outputs the results of the bandwidth search. (Network and impedance analyzer only)
(WIDTHS ON off under Search); Query only)

■ Query Response

{*numeric (bandwidth)*} {*numeric (center)*} {*numeric (Q)*} <new line><END>

■ Equivalent SCPI Command

:CALCulate:EVALuate:WIDTh:DATA?

■ Example

```
OUTPUT 717;"OUTPMWID?"
ENTER 717;A,B,C

OUTPUT 717;":CALC:EVAL:WIDT:DATA?"
ENTER 717;A,B,C
```

OUTPRAW{1-4}?

Outputs the uncorrected data arrays for the active channel. (Query only)

- Query Response

{*numeric (1)*} {*numeric (2)*} ... {*numeric (n)*} <new line><END>

(n is the number of points.)

numeric is a complex number (data format: real, imaginary) for the Network analyzer, or a real number for the Spectrum analyzer.

- Equivalent SCPI Command

:DATA[:DATA]?LRAW{1-4}

OUTPRESF?

Outputs resonator parameters. See "OUTPRESF?" in Appendix I for details, query response, and examples. (Instrument BASIC EXECUTE executable; No equivalent SCPI command; Query only; Network analyzer only)

OUTPRESO?

Outputs resonator parameters. See "OUTPRESO?" in Appendix I for details, query response, and examples. (Instrument BASIC EXECUTE executable; No equivalent SCPI command; Query only; Network analyzer only)

OUTPRESR?

Outputs resonator parameters. See "OUTPRESR?" in Appendix I for details, query response, and examples. (Instrument BASIC EXECUTE executable; No equivalent SCPI command; Query only; Network analyzer only)

OUTPSMKR{1-7}?

Outputs the measurement values and sweep parameter at the sub-marker position. (Query only)

- Query Response

{*numeric (val1)*} {*numeric (val2)*} {*numeric (stimulus)*} <new line><END>

(Val1: Amplitude value, Val2: Auxiliary amplitude value. See "Marker Readout" in Appendix H.)

- Equivalent SCPI Command

```
OUTPSMKR1? :CALCulate:EVALuate:Y2:DATA?
OUTPSMKR2? :CALCulate:EVALuate:Y3:DATA?
OUTPSMKR3? :CALCulate:EVALuate:Y4:DATA?
OUTPSMKR4? :CALCulate:EVALuate:Y5:DATA?
OUTPSMKR5? :CALCulate:EVALuate:Y6:DATA?
OUTPSMKR6? :CALCulate:EVALuate:Y7:DATA?
OUTPSMKR7? :CALCulate:EVALuate:Y8:DATA?
```

OUTPSMKR{1-7}?

OUTPSWPRM?

Outputs the sweep parameter data. (Query only)

■ Query Response

{*numeric 1*} {*numeric 2*} ... {*numeric n*} <new line><END>

(n is the number of points.)

■ Equivalent SCPI Command

:DATA[:DATA]?LSPAR

OUTPSWPRMP?<numeric>

Outputs the sweep parameter data at a specified point. (Query only)

Parameter	Description
<numeric>	1 to "number of points" (If <numeric> is 0 or less than 0, it is set to 1. If <numeric> is greater than "number of points," it is set to "number of points.")

■ Query Response

{numeric} <new line><END>

■ Equivalent SCPI Command

:DATA[:DATA]:VALue?LSPAR,<numeric>

OUTPXFIL?

Outputs crystal filter parameters. See "OUTPXFIL?" in Appendix I for details, query response, and examples. (Instrument BASIC EXECUTE executable; No equivalent SCPI command; Query only; Network analyzer only)

PARSL{OFF|ON|0|1}

Sets the partial search of the marker search function ON or OFF. (PART SRCH ON off under Search)

Parameter	Description
OFF or 0	Partial search OFF
ON or 1	Partial search ON

- Query Response

{0|1} <new line><END>

- Equivalent SCPI Command

:CALCulate:EVALuate:BAND:FULL[:STATE]L{OFF|ON|0|1}

Parameter	Description
OFF or 0	Partial search ON
ON or 1	Partial search OFF

- Example

```
OUTPUT 717;"PARS ON"
OUTPUT 717;"PARS?"
ENTER 717;A
OUTPUT 717;":CALC:EVAL:BAND:FULL OFF"
OUTPUT 717;":CALC:EVAL:BAND:FULL?"
ENTER 717;A
```

PEAK?

Outputs maximum peak within analysis range, and memorizes its position for the NEXPK? command. See "PEAK?" in Appendix I for details, query response, and examples. (Instrument BASIC EXECUTE executable; No equivalent SCPI command; Query only; Network and spectrum analyzer only)

PEAKCENT

Searches for a peak using the marker and then changes the CENTER of the destination channel to the sweep parameter value of that peak. (PEAK→CENTER under Center or Marker→; No query)

- Equivalent SCPI Command

:SENSe:FREQuency:CENTerLTPEak (frequency) or
:SOURce:POWer:CENTerLTPEak (power)

PEAKCENT

PHAO <numeric> [DEG]

Adds or subtracts a phase offset that is constant with frequency. (Network analyzer only)
(PHASE OFFSET under Scale Ref)

Parameter	Range	Unit
<numeric>	-360 to +360	°

■ Query Response

{numeric} <new line><END>

■ Equivalent SCPI Command

:SENSe:CORRection:OFFSet:PHASe <numeric>

PHAU {RAD|DEG}

Selects the unit of phase format. (PHASE UNIT under Format; Impedance analyzer only.)

Parameter	Description
DEG	Degree.
RAD	Radian.

■ Query Response

{DEG|RAD} <new line><END>

■ Equivalent SCPI Command

:CALCulate:FORMat:UNIT:ANGLE {DEG|RAD}

PKDLTX <numeric> [HZ|KHZ|MAHZ|GHZ|DBM]

Sets the peak ΔX value that is used to define the peak. (PEAK DELTA: ΔX under Search)

Parameter	Range	Unit
<numeric>	-5×10^{10} (= -50 G) to 5×10^{10} (= 50 G) 0 to 500	Hz (frequency) dBm (power)

■ Query Response

{numeric} <new line><END>

■ Equivalent SCPI Command

:CALCulate:EVALuate:PEAK:EXCursion:X <numeric>

- Example

```
OUTPUT 717;"PKDLTX 1E6"
OUTPUT 717;"PKDLTX?"
ENTER 717;A

OUTPUT 717;":CALC:EVAL:PEAK:EXC:X 1E6"
OUTPUT 717;":CALC:EVAL:PEAK:EXC:X?"
ENTER 717;A
```

PKDLTY <numeric>

Sets the peak ΔY value that is used to define the peak. (PEAK DELTA: ΔY under [Search](#))

Parameter	Range	Unit
<numeric>	0 to 5×10^5	

- Query Response

{numeric} <new line><END>

- Equivalent SCPI Command

:CALCulate:EVALuate:PEAK:EXCursion:Y<numeric>

PKPOL {POS|NEG}

Sets the peak polarity for the marker search functions. (Network and impedance Analyzer only) (PEAK PLRTY pos neg under [Search](#))

Parameter	Description
POS	Positive peak
NEG	Negative peak

- Query Response

{POS|NEG} <new line><END>

- Equivalent SCPI Command

:CALCulate:EVALuate:PEAK:POLarity{POSitive|NEGative}

PKPOL {POS|NEG}

PKTHRE {OFF|ON|0|1}

Sets the threshold ON or OFF. (THRESHOLD ON off under [Search](#))

Parameter	Description
OFF or 0	Threshold OFF
ON or 1	Threshold ON

■ Query Response

{0|1} <new line><END>

■ Equivalent SCPI Command

:CALCulate:EVALuate:PEAK:THReshold:STATe {OFF|ON|0|1}

PKTHVAL <value>

Sets the threshold values. (THRESHOLD VALUE under [Search](#))

Parameter	Range	Unit
<numeric>	-500 to 500	(Log mag format)
	-5×10 ⁶ to 5×10 ⁶	(Phase, Expanded phase, Lin man, Real, Imaginary, SWR formats)
	-0.5 to 0.5	(Delay format)
	1×10 ⁻¹¹ to 500	(Smith chart, Admittance chart, Polar formats)
	-100 to 30	(dBm format)
	-113 to 17 (50 Ω)	(dBV format)
	-111.2 to 18.8 (75 Ω)	
	7 to 137 (50 Ω)	(dBμV format)
	8.8 to 138.8 (75 Ω)	
	1×10 ⁻¹³ to 1	(Watt format)
	1×10 ⁻⁶ to 7.071 (50 Ω)	(Volt format)
	1×10 ⁻⁶ to 8.66 (75 Ω)	

■ Query Response

{numeric} <new line><END>

■ Equivalent SCPI Command

:CALCulate:EVALuate:PEAK:THReshold <numeric>

PLOC {ALL|DGRAT|DONLY}

Selects the plot elements. (PLOT: ALL, DATA&GRTCL, DATA ONLY under **Copy**)

Parameter	Description
ALL	All information displayed
DGRAT	Data and graticule
DONLY	Data only

■ Query Response

{ALL|DGRAT|DONLY} <new line><END>

■ Equivalent SCPI Command

```
PLOC|ALL      :HCOPY:ITEM:ANNotation:STATe|{ON|1}
               :HCOPY:ITEM:GRATicule:STATe|{ON|1}

PLOC|DGRAT    :HCOPY:ITEM:ANNotation:STATe|{OFF|0}
               :HCOPY:ITEM:GRATicule:STATe|{ON|1}

PLOC|DONLY    :HCOPY:ITEM:ANNotation:STATe|{OFF|0}
               :HCOPY:ITEM:GRATicule:STATe|{OFF|0}
```

■ Example

```
OUTPUT 717;"PLOC ALL"
OUTPUT 717;"PLOC?"
ENTER 717;A$

OUTPUT 717;":HCOP:ITEM:ANN:STAT ON"
OUTPUT 717;":HCOP:ITEM:GRAT:STAT ON"

OUTPUT 717;":HCOP:ITEM:ANN:STAT?"
ENTER 717;A
OUTPUT 717;":HCOP:ITEM:GRAT:STAT?"
ENTER 717;B
```

PLOC \square {ALL|DGRAT|DONLY}

PLOS \square {FAST|SLOW}

Sets the plotting speed to fast or slow. (PLOT SPEED [] under **Copy**)

Parameter	Description
FAST	Fast plot speed (for normal plotting).
SLOW	Slow plot speed (for plotting directly on transparencies).

■ Query Response

{FAST|SLOW} <new line><END>

■ Equivalent SCPI Command

:HCOPY:DRIVER:SPEEd \square {1|2}

Parameter	Description
1	SLOW
2	FAST

■ Example

OUTPUT 717;"PLOS SLOW"

PLOT

Plots the display to a compatible HP graphics plotter, using the currently defined plot parameters. (PLOT under **Copy**; No query)

■ Equivalent SCPI Command

:HCOPY:DRIVER:LANGuage \square HPGL
:HCOPY[:IMMediate]

POIN \square <numeric>

Sets the number of points for the segment, or sets the number of points for the list sweep table. (NUMBER OF POINTS under **Sweep**)

Parameter	Description
<numeric>	2 to 801. ¹

¹ For the spectrum analyzer, <numeric> can be set when the SPAN is set to zero. When the SPAN is not zero, this command is query only.

■ Query Response

{numeric} <new line><END>

■ Equivalent SCPI Command

:SENSe:SWEep:POINts \square <numeric> or
:SENSe:LIST:SEGment:POINts \square <numeric> (List sweep)

POLE?<numeric>

Outputs the first found negative peaks for both side from the maximum peak. Negative peaks must be lower than the <numeric> down from the maximum peak. See "POLE?" in Appendix I for details, command paramter, query response, and examples. (Instrument BASIC EXECUTE executable; No equivalent SCPI command; No query; Network and spectrum analyzer only)

PORE{OFF|ON|0|1}

Sets the reference plane extension mode ON or OFF. (Network and impedance analyzer only)
(EXTENSIONS ON off under Cal)

Parameter	Description
OFF or 0	Reference plane extension mode OFF
ON or 1	Reference plane extension mode ON

■ Query Response

{0|1} <new line><END>

■ Equivalent SCPI Command

:SENSe:CORRection:EDELay:STATe{OFF|ON|0|1}

PORT1<numeric>[S|MS|US|NS|PS]

Extends the reference plane for measurement of S₁₁, S₂₁, and S₁₂. (Network analyzer only)
(EXTENSION PORT 1 under Cal)

Parameter	Range	Unit
<numeric>	-10 to 10	s

■ Query Response

{numeric} <new line><END>

■ Equivalent SCPI Command

:SENSe:CORRection:EDELay:PORT1:TIME<numeric>

PORT1 \square *<numeric>* [S|MS|US|NS|PS]

PORT2 \square *<numeric>* [S|MS|US|NS|PS]

Extends the reference plane for measurement of S_{22} , S_{12} , and S_{21} . (Network analyzer only)
(EXTENSION PORT 2 under Cal)

Parameter	Range	Unit
<i><numeric></i>	-10 to 10	s

■ Query Response

{*numeric*} <new line><END>

■ Equivalent SCPI Command

:SENSe:CORRection:EDELay:PORT2:TIME \square *<numeric>*

PORTA \square *<numeric>* [S|MS|US|NS|PS]

Adds electrical delay to the input A reference plan for all A input measurements (including S-parameters). (Network analyzer only) (EXTENSION INPUT A under Cal)

Parameter	Range	Unit
<i><value></i>	-10 to 10	s

■ Query Response

{*numeric*} <new line><END>

■ Equivalent SCPI Command

:SENSe:CORRection:EDELay:PORT4:TIME \square *<numeric>*

PORTB \square *<numeric>* [S|MS|US|NS|PS]

Adds electrical delay to the input B reference plane for all B input measurements (including S-parameters). (Network analyzer only) (EXTENSION INPUT B under Cal)

Parameter	Range	Unit
<i><numeric></i>	-10 to 10	s

■ Query Response

{*numeric*} <new line><END>

■ Equivalent SCPI Command

:SENSe:CORRection:EDELay:PORT5:TIME \square *<numeric>*

PORTR<numeric>[S|MS|US|NS|PS]

Adds electrical delay to extend the reference plane at input R to the end of cable. (Network analyzer only) (EXTENSION INPUT R under Cal)

Parameter	Range	Unit
<value>	-10 to 10	s

■ Query Response

{numeric} <new line><END>

■ Equivalent SCPI Command

:SENSe:CORRection:EDELay:PORT3:TIME<numeric>

PORTZ<numeric>

Sets the port extension value. (EXTENSION VALUE under Cal; Impedance analyzer only.)

■ Query response

<numeric><new line><END>

■ Equivalent SCPI command

:SENSe:CORRection1:EDELay:PORT6[:TIME]<numeric>

POWER<numeric>[DBM]

Sets the power level segment by segment, or sets the power level for the list sweep table. (Network and impedance analyzer only) (POWER under Sweep)

Parameter	Range	Unit
<numeric>	-70 to +20	dBm

■ Query Response

{numeric} <new line><END>

■ Equivalent SCPI Command

:SOURce:POWER[:LEVel][:IMMediate][:AMPLitude]<numeric> or

:SENSe:LIST:SEGMENT:POWER <numeric> (List sweep)

POWER<numeric>[DBM]

PREP

Displays the previous page of information in a tabular listing. (PREV PAGE under Copy); No query)

■ Equivalent SCPI Command

:DISPlay[:WINDow]:TEXT{1-17}:PAGE↓DOWN

Parameter	Description
1	List Value
2	Operation Parameter
3	Cal Class
4 to 11	Cal Standard No. 1 to No. 8
12	Start and Stop
13	Center and Span (List)
14	Upper and Lower
15	Middle and Delta (Limit Test)
16	Marker List
17	Title

PRES

Presets the ANALYZER to the preset default values. See Appendix D of the *Function Reference* for the default values. The PRES command does *not* preset the HP Instrument BASIC. (PRESET); No query)

■ Equivalent SCPI Command

:SYSTem:PRESet

PRIC

Sets the print command to the color printing. (COLOR under Copy)

■ Query Response

{0|1} <new line><END>

Parameter	Description
0	Single-color printing
1	Color printing

■ Equivalent SCPI Command

:HCOPy:DRIVer:COLor↓{ON|1}

PRICFIXE

Sets the default colors for printing a hard copy. (PRINT COLOR [FIXED] under **Copy**)

■ Query Response

{0|1} <new line><END>

Parameter	Description
0	Variable colors (colors similar to the display)
1	Fixed colors (default colors)

■ Equivalent SCPI Command

:HCOpy:DRIVer:CMAP:COLorL\FIXed

PRICVARI

Sets the colors used for printing a hard copy as close as possible to the display colors. (PRINT COLOR [VARIABLE] under **Copy**)

■ Query Response

{0|1} <new line><END>

Parameter	Description
0	Fixed colors (default colors)
1	Variable colors (colors similar to the display)

■ Equivalent SCPI Command

:HCOpy:DRIVer:CMAP:COLorL\VARiable

PRINALL

Causes an extra copy of the display to be printed. (PRINT [] under **Copy**; No query)

■ Equivalent SCPI Command

:HCOpy:DRIVer:LANGuageL\PCL
:HCOpy[:IMMediate]

PRINALL

PRIS

Sets the print command to the single color printing. (PRINT: STANDARD under **Copy**)

■ Query Response

{0|1} <new line><END>

Parameter	Description
0	Color printing
1	Single color printing

■ Equivalent SCPI Command

:HCOpy:DRIVer:COLOr{OFF|0}

□ Query Response

Parameter	Description
0	Default printing (black only)
1	Color printing

PRSMKRS

Turns off all markers and cancels all settings of the marker functions. (PRESET MKRS under **Marker**); No query)

■ Equivalent SCPI Command

:DISPlay[:WINDow]:TRACe{[1]|2}:MARKer[1]:ALLDEFault
(TRACe[1] for the data trace; TRACe2 for the memory trace.)

PSOFT{OFF|ON|0|1}

Sets the plot softkey label option ON or OFF. (No query)

Parameter	Description
OFF or 0	Plot softkey label option OFF
ON or 1	Plot softkey label option ON

■ Equivalent SCPI Command

:HCOpy:ITEM:MENU:STATe{OFF|ON|0|1}

PURG{<string>

Removes the file. (PURGE FILE under **SAVE**); No query

Parameter	Description
<string>	File name, up to 10 characters including the extension

■ Equivalent SCPI Command

:MMEMory:DELeTe{<string (file_name)> [, <string (msus)>]}

Parameter	Description
<string (msus)>	"DISK" for the flexible disk drive "MEMORY" for the RAM disk memory

■ Example

OUTPUT 717;"PURG ""TEST_S""

OUTPUT 717;":MMEM:DEL ""TEST_S""

QUAD{LEFU|LEFL|RIGU|RIGL|FULP}

Selects the quadrant plot setting. (SELECT QUADRANT under **Copy**); No query for the SCPI command)

Parameter	Description
LEFU	Upper left
LEFL	Lower left
RIGU	Upper right
RIGL	Lower right
FULP	Full-size

■ Query Response

{LEFU|LEFL|RIGU|RIGL|FULP} <new line><END>

■ Equivalent SCPI Command

QUAD{LEFU} :HCOPY:PAGE:DIMensions:QUADrant2

QUAD{LEFL} :HCOPY:PAGE:DIMensions:QUADrant3

QUAD{RIGU} :HCOPY:PAGE:DIMensions:QUADrant1

QUAD{RIGL} :HCOPY:PAGE:DIMensions:QUADrant4

QUAD{FULP} :HCOPY:PAGE:DIMensions:FULL

■ Example

OUTPUT 717;"QUAD LEFU"

OUTPUT 717;"QUAD?"

ENTER 717;A\$

OUTPUT 717;":HCOP:PAGE:DIM:QUAD2"

QUAD{LEFU|LEFL|RIGU|RIGL|FULP}

RAID

Completes the response and isolation calibration. Computes and stores the error coefficients. (Network analyzer only) (**DONE RESP ISOL'N CAL** under **Cal**); No query)

- Equivalent SCPI Command

:SENSe:CORRection:COLLect:SAVE3

RAISOL

Selects the isolation class for the response and isolation calibration. (Network analyzer only) (**ISOL'N STD** under **Cal**); No query)

- Equivalent SCPI Command

:SENSe:CORRection:COLLect[:ACQuire]ISOL

RAIRESP

Selects the response class for the response and isolation calibration. (Network analyzer only) (**RESPONSE** under **Cal**); No query)

- Equivalent SCPI Command

:SENSe:CORRection:COLLect[:ACQuire]IRESP

RECC

Recalls the previously saved version of the color set from the non-volatile memory. (**RECALL COLORS** under **Display**); No query)

- Equivalent SCPI Command

:DISPlay:CMAP:LOAD

RECD□<string>

Loads the instrument states or data. (file name under **Recall**); No query)

Parameter	Description
<string>	File name, Up to 10 characters including the extension

- Equivalent SCPI Command

:MMEMory:LOAD:STATe□<string (file_name)>[, <string (msus)>] (State)

:MMEMory:LOAD:TRACe□SEL, <string (file_name)>[, <string (msus)>] (Data)

Parameter	Description
<string (file_name)>	File name, Up to 10 characters including the extension
<string (msus)>	"DISK" for the flexible disk drive "MEMORY" for the RAM disk memory

- Example

```
OUTPUT 717;"RECD ""TEST_S""
```

```
OUTPUT 717;":MMEM:LOAD:STAT ""TEST_S""
```

REFD

Completes with the reflection part of the full 2-port or one-path 2-port calibration. (Network analyzer only) (**REFLECT'N DONE** under **Cal**); No query)

- Equivalent SCPI Command

:SENSe:CORRection:COLLect:SAVE5

REFL

Begins the reflection part of the full 2-port or one-path 2-port calibration. (Network analyzer only) (**REFLECT'N** under **Cal**); No query)

- Equivalent SCPI Command

:SENSe:CORRection:COLLect[:ACQuire]□REFL2

REFP□<numeric>

Sets the position of the reference line on the graticule of a Cartesian display. (Network and impedance analyzer only) (**REFERENCE POSITION** under **Scale Ref**)

Parameter	Range	Unit
<numeric>	0 to 10	Div

- Equivalent SCPI Command

:DISPlay[:WINDow]:TRACe{[1]|2}:Y[:SCALE]:RPOSition□<numeric>

(TRACe[1] for the data trace; TRACe2 for the memory trace.)

REFP□<numeric>

REFV□<numeric>

Sets the value of the reference line, moving the measurement trace correspondingly.
(**REFERENCE VALUE** under **Scale Ref**)

Parameter	Range	Unit
<numeric>	-500 to 500	(Log mag format)
	-5×10^6 to 5×10^6	(Phase, Expanded phase, Lin man, Real, Imaginary, SWR formats)
	-0.5 to 0.5	(Delay format)
	1×10^{-11} to 500	(Smith chart, Admittance chart, Polar formats)
	-100 to 30	(dBm format)
	-113 to 17 (50 Ω)	(dBV format)
	-111.2 to 18.8 (75 Ω)	
	7 to 137 (50 Ω)	(dBμV format)
	8.8 to 138.8 (75 Ω)	
	1×10^{-13} to 1	(Watt format)
	1×10^{-6} to 7.071 (50 Ω)	(Volt format)
	1×10^{-6} to 8.66 (75 Ω)	

■ Query Response

{numeric} <new line><END>

■ Equivalent SCPI Command

:DISPlay[:WINDow]:TRACe{[1]|2}:Y[:SCALE]:RLEVel□<numeric>
(TRACe[1] for the data trace; TRACe2 for the memory trace.)

REFX□<numeric>

Sets the value of the x-axis reference line in complex plane format, moving the measurement trace correspondingly, when the measurement format is set to the complex plane.
(**REFERENCE X VALUE** under **Scale Ref**); Impedance analyzer only.)

Parameter	Range	Unit
<numeric>	-5.0×10^8 to 5.0×10^8	U

■ Query Response

<numeric><new line><END>

■ Equivalent SCPI Command

:DISPlay[:WINDow]:TRACe{1|2}:X[:SCALE]:RLEVel□<numeric>

REFY{<numeric>

Sets the value of the y-axis reference line in complex plane format, moving the measurement trace correspondingly, when the measurement format is set to the complex plane.

(REFERENCE Y VALUE under **Scale Ref**)

Parameter	Range	Unit
<numeric>	-5.0x10 ⁸ to 5.0x10 ⁸	U

■ Query Response

<numeric><new line><END>

■ Equivalent SCPI Command

:DISPlay[:WINDow]:TRACe{1|2}:Y[:SCALe]:RLEVel{<numeric>

Where,

TRACe1 Data trace
TRACe2 Memory trace

REPTSMP{OFF|ON|0|1}

Sets the normal or repetitive sampling mode for zero span. (Spectrum analyzer only).

(SAMPLING NORMAL repet under **Sweep**; No query for the Simple command)

Parameter	Description
OFF or 0	Normal sampling
ON or 1	Repetitive sampling ¹

¹ Can be set only when the trigger source is the external or video trigger, the frequency span is 0 Hz, and the sweep type is linear frequency.

■ Equivalent SCPI Command

:SENSe:DETEctor:CONTinuous{OFF|ON|0|1}

REPTSMP {OFF|ON|0|1}

RESAVD <string>

Updates a file that is already saved. (**RE-SAVE FILE** under **Save**); No query)

Parameter	Description
<string>	File name up to 10 characters including the extension

■ Equivalent SCPI Command

STATE :MMEMory:DELEte <string (file_name)> [, <string (msus)>]
:MMEMory:STORe:STATe <string (file_name)> [, <string (msus)>]
TRACE :MMEMory:DELEte <string (file_name)> [, <string (msus)>]
:MMEMory:STORe:TRACe [SEL, <string (file_name)> [, <string (msus)>]

Parameter	Description
<string (msus)>	"DISK" for the flexible disk drive "MEMORY" for the RAM disk memory

■ Example

```
OUTPUT 717;"RESAVD ""TEST_S""  
OUTPUT 717;" :MMEM:DEL ""TEST_S""  
OUTPUT 717;" :MMEM:STOR:STAT ""TEST""
```

RESC

Eliminates the need to restart a calibration sequence that was interrupted to access some other menu. (Network and impedance analyzer only) (**RESUME CAL SEQUENCE** under **Cal**); No query)

■ Equivalent SCPI Command

:SENSe:CORRection:COLLect:RESume

RESCOM

Resume the last measured compensation sequence. (**RESUME COMP SEQ** under **Cal**); No query; Impedance analyzer only.)

■ Equivalent SCPI Command

:SENSe:CORRection2:COLLect:RESume

RESD

Turns off the tabular listing and returns the measurement display to the screen. (RESTORE DISPLAY under **Copy**); No query

- Equivalent SCPI Command

:DISPlay[:WINDow]:TEXT{1-17}:STATelJOFF

Parameter	Description
1	List Value
2	Operation Parameter
3	Cal Class
4 to 11	Cal Standard No. 1 to No. 8
12	Start and Stop
13	Center and Span (List)
14	Upper and Lower
15	Middle and Delta (Limit Test)
16	Marker List
17	Title

RESPDONE

Completes the response calibration. Computes and stores the error coefficients. (Network analyzer only) (DONE: RESPONSE under **Cal**); No query

- Equivalent SCPI Command

:SENSe:CORRection:COLLect:SAVE2

REST

Aborts the sweep in progress and then restarts the measurement. (MEASURE RESTART under **Trigger**); No query

- Equivalent SCPI Command

:INITiate[:IMMediate]:AGain:ALL

REVI

Measures S_{12} isolation for the full 2-port calibration. (Network analyzer only) (REV ISOL'N ISOL'N STD under **Cal**); No query

- Equivalent SCPI Command

:SENSe:CORRection:COLLect[:ACQuire]UREVI

REVM

Measures S_{22} load match for the full 2-port calibration. (Network analyzer only) (REV. MATCH THRU under **Cal**); No query

- Equivalent SCPI Command

:SENSe:CORRection:COLLect[:ACQuire]UREVM

2: Commands Reference

REVM

REVT

Measures S_{12} frequency response for the full 2-port calibration. (Network analyzer only)
(REV. TRANS. THRU under **Cal**); No query)

- Equivalent SCPI Command

:SENSe:CORRection:COLLect[:ACQuire]UREVT

RFO{OFF|ON|0|1}

Sets the signal output on the RF OUT port ON or OFF. (RF OUT ON off under **Source**)

Parameter	Description
OFF or 0	RF OUT port OFF
ON or 1	RF OUT port ON

- Query Response

{0|1} <new line><END>

- Equivalent SCPI Command

:SOURce:POWer:STATe{OFF|ON|0|1}

RPLENV?

Returns the maximum height between the negative peak and intersection of an imaginary slope line between the adjacent positive peaks. See "RPLENV?" in Appendix I for details, query response, and examples. (Instrument BASIC EXECUTE executable; No equivalent SCPI command; Query only; Network and spectrum analyzer only)

RPLHEI?

Returns the maximum difference between adjacent positive and negative peaks. See "RPLHEI?" in Appendix I for details, query response, and examples. (Instrument BASIC EXECUTE executable; No equivalent SCPI command; Query only; Network and spectrum analyzer only)

RPLLHEI?

Returns the maximum difference between the positive peak and right-hand adjacent negative peak. See "RPLLHEI?" in Appendix I for details, query response, and examples. (Instrument BASIC EXECUTE executable; No equivalent SCPI command; Query only; Network and spectrum analyzer only)

RPLMEA?

Returns the mean of the difference between adjacent positive and negative peaks within range. See "RPLPP?" in Appendix I for details, query response, and examples. (Instrument BASIC EXECUTE executable; No equivalent SCPI command; Query only; Network and spectrum analyzer only)

RPLPP?

Returns the maximum difference between the positive peak and the negative peak within range. See "RPLPP?" in Appendix I for details, query response, and examples. (Instrument BASIC EXECUTE executable; No equivalent SCPI command; Query only; Network and spectrum analyzer only)

RPLRHEI?

Returns the maximum difference between the positive peak and left-hand adjacent negative peak. See "RPLRHEI?" in Appendix I for details, query response, and examples. (Instrument BASIC EXECUTE executable; No equivalent SCPI command; Query only; Network and spectrum analyzer only)

RPLVAL?

Returns the maximum total of the differences between the negative peaks and the adjacent positive peaks on both sides and the stimulus of the corresponding negative peak. See "RPLPP?" in Appendix I for details, query response, and examples. (Instrument BASIC EXECUTE executable; No equivalent SCPI command; Query only; Network and spectrum analyzer only)

RSCO

Resets the color being modified to the default color. (**RESET COLOR** under **Display**); No query)

■ Equivalent SCPI Command

DISPlay:CMAP:COLor{1-14}:DEFault

Parameter	Description
1	Channel 1 data
2	Channel 1 memory and limit lines
3	Channel 2 data
4	Channel 2 memory and limit lines
5	Graticule and a portion of softkey text
6	Warning annotation
7	All the non-data text
8	Text on the BASIC screen
9-14	Pen 1-6

RSCO

SA

Selects the spectrum analyzer as the analyzer type. (SPECTRUM ANALYZER under Meas)

■ Query Response

{0|1} <new line><END>

Parameter	Description
0	Spectrum analyzer is not selected.
1	Spectrum analyzer is selected.

■ Equivalent SCPI Command

:INSTrument:TYPELISA

■ Example

```
OUTPUT 717;"SA"  
OUTPUT 717;"SA?"  
ENTER 717;A  
  
OUTPUT 717;":INST:TYPE SA"  
OUTPUT 717;":INST:TYPE?"  
ENTER 717;A$
```

SADD

Adds a new segment to a list sweep table. (ADD under Sweep); No query)

■ Equivalent SCPI Command

:SENSe:LIST:SEGMENT:ADD

SAUNIT {DBM|DBV|DBUV|W|V}

Selects the measurement data unit of the spectrum analyzer on the active channel. (Spectrum analyzer only) (UNIT: dBm, dBV, dB μ V, WATT, VOLT under Format)

Parameter	Description
DBM	dBm
DBV	dBV
DBUV	dB μ V
W	Watt
V	Volt

- Query Response

```
{DBM|DBV|DBUV|W|V} <new line><END>
```

- Equivalent SCPI Command

```
SAUNIT:DBM :CALCulate:FORMat:MLOGarithmic
:UNIT:POWer:DBM

SAUNIT:DBV :CALCulate:FORMat:MLOGarithmic
:UNIT:POWer:DBV

SAUNIT:DBUV :CALCulate:FORMat:MLOGarithmic
:UNIT:POWer:DBUV

SAUNIT:W :CALCulate:FORMat:MLINear
:UNIT:POWer:W

SAUNIT:V :CALCulate:FORMat:MLINear
:UNIT:POWer:V
```

- Example

```
OUTPUT 717;"SAUNIT DBM"
OUTPUT 717;"SAUNIT?"
ENTER 717;A$

OUTPUT 717;":CALC:FORM MLOG"
OUTPUT 717;":UNIT:POW DBM"

OUTPUT 717;":CALC:FORM?"
ENTER 717;A$
OUTPUT 717;":UNIT:POW?"
ENTER 717;B$
```

SAV1

Completes the S_{11} or S_{22} 1-port calibration. The error coefficients are computed and stored. (Network analyzer only) (DONE: 1-PORT CAL under **Cal**); No query)

- Equivalent SCPI Command

```
:SENSe:CORRection:COLLect:SAVE4
```

SAV2

Completes the full or one-path 2-port calibration. The error coefficients are computed and stored. (Network analyzer only) (DONE: 2-PORT CAL under **Cal**); No query)

- Equivalent SCPI Command

```
:SENSe:CORRection:COLLect:SAVE8
```

SAVC

Redraws a trace using the current error coefficient array data. (Network and impedance analyzer only) (No query)

- Equivalent SCPI Command

```
:SENSe:CORRection:COLLect:SAVE9
```

SAVC

SAVCAL {OFF|ON|0|1}

Selects whether or not to save the calibration coefficients arrays. (CAL ON off under **Save**); No query for the SCPI command)

Parameter	Description
OFF or 0	Does not save the calibration coefficients arrays.
ON or 1	Saves the calibration coefficients arrays.

■ Query Response

{0|1} <new line><END>

■ Equivalent SCPI Command

SAVCAL {OFF|0} :MMEMory:STORe:ITEM:TRACe{1|2}:DELeteLCCO

SAVCAL {ON|1} :MMEMory:STORe:ITEM:TRACe{1|2}:SELectLCCO

SAVCOM

Calculates the fixture compensation coefficients and store it. (DONE: COMPEN under **Cal**); No query; Impedance analyzer only)

■ Equivalent SCPI Command

:SENSe:CORRection2:COLLect:SAVE

SAVDASC <string>

Specifies saving the internal data arrays as an ASCII file. (DATA ONLY (ascii) under **Save**); No query)

Parameter	Description
<string>	File name, up to 8 characters

■ Equivalent SCPI Command

:MMEMory:STORe:DINTerchange:TRACeLSEL, <string (file_name)> [, <string (msus)>]

Parameter	Description
<string (msus)>	"DISK" for the flexible disk drive "MEMORY" for the RAM disk memory

■ Example

OUTPUT 717;"SAVDASC ""DATA1""

OUTPUT 717;":MMEM:STOR:DINT:TRAC SEL, ""DATA1""

SAVDAT *<{OFF|ON|0|1}>*

Selects whether or not to save the data arrays. (DATA ON off under **Save**); No query for the SCPI command)

Parameter	Description
OFF or 0	Does not save the data arrays.
ON or 1	Saves the data arrays.

- Query Response

{0|1} <new line><END>

- Equivalent SCPI Command

SAVDAT *<{OFF|0}>* :MMEMory:STORe:ITEM:TRACe{1|2}:DELete *<DATA>*
 SAVDAT *<{ON|1}>* :MMEMory:STORe:ITEM:TRACe{1|2}:SELect *<DATA>*

- Example

```
OUTPUT 717;"SAVDAT ON"
```

SAVDDAT *<string>*

Specifies saving the internal data arrays which are defined by the SAVRAW, SAVCAL, SAVDAT, SAVMEM, SAVDAT, and SAVTMEM commands. (DATA ONLY (binary) under **Save**); No query)

Parameter	Description
<i><string></i>	File name up to 8 characters

- Equivalent SCPI Command

:MMEMory:STORe:TRACe *<SEL>*, *<string (file_name)>* [, *<string (msus)>*]

Parameter	Description
<i><string (msus)></i>	"DISK" for the flexible disk drive "MEMORY" for the RAM disk memory

- Example

```
OUTPUT 717;"SAVDDAT ""DATA1"""
```

```
OUTPUT 717;":MMEM:STOR:TRAC SEL, ""DATA1"""
```

SAVDGRA *<string>*

Specifies saving the graphic image on the screen as an HP-GL file. (GRAPHICS under **Save**); No query)

Parameter	Description
<i><string></i>	File name up to 8 characters

SAVDGRA□<string>

■ Equivalent SCPI Command

:MMEMory:STORe:DINTerchange:GRAPhics□<string (file_name)> [, <string (msus)>]

Parameter	Description
<string (msus)>	"DISK" for the flexible disk drive "MEMORY" for the RAM disk memory

■ Example

```
OUTPUT 717;"SAVDGRA ""GRA1""
```

```
OUTPUT 717;":MMEM:STOR:DINT:GRAP ""GRA1""
```

SAVDSTA□<string>

Specifies saving only the instrument states and the calibration coefficients. (STATE under **Save**); No query)

Parameter	Description
<string>	File name up to 8 characters

■ Equivalent SCPI Command

:MMEMory:STORe:STATe□<string (file_name)> [, <string (msus)>]

Parameter	Description
<string (msus)>	"DISK" for the flexible disk drive "MEMORY" for the RAM disk memory

■ Example

```
OUTPUT 717;"SAVDSTA ""STA1""
```

```
OUTPUT 717;":MMEM:STOR:STAT ""STA1""
```

SAVDTRC□{OFF|ON|0|1}

Sets whether or not to save the trace arrays. (DATA TRACE ON off under **Save**); No query for the SCPI command)

Parameter	Description
OFF or 0	Does not save the trace arrays.
ON or 1	Saves the trace arrays.

■ Query Response

```
{0|1} <new line><^END>
```

■ Equivalent SCPI Command

```
SAVDTRC□{OFF|0} :MMEMory:STORe:ITEM:TRACe{1|2}:DELete□DTR
```

```
SAVDTRC□{ON|1} :MMEMory:STORe:ITEM:TRACe{1|2}:SELect□DTR
```

SAVEUSEK

Stores the user-modified or user-defined calibration kit into memory. (Network and impedance analyzer only) (SAVE USER KIT under **Cal**); No query)

- Equivalent SCPI Command

```
:SENSe:CORRection:CKIT:MODify:SAVE
```

SAVIMP

Calculates the error-correction coefficients from the calibration data and stores the coefficients. (DONE:CAL under **CAL**); No query; Impedance analyzer only)

- Equivalent SCPI Command

```
:SENSe:CORRection1:COLLect:SAVE
```

SAVMEML{OFF|ON|0|1}

Specifies whether or not to save the memory arrays. (MEM ON off under **Save**); No query for the SCPI command)

Parameter	Description
OFF or 0	Does not save the memory arrays.
ON or 1	Saves the memory arrays.

- Query Response

```
{0|1} <new line><END>
```

- Equivalent SCPI Command

```
SAVMEML{OFF|0} :MMEMory:STORe:ITEM:TRACe{1|2}:DELeteLMEM
SAVMEML{ON|1} :MMEMory:STORe:ITEM:TRACe{1|2}:SELectLMEM
```

SAVMTRCL{OFF|ON|0|1}

Specifies whether or not to save the memory trace arrays. (MEM TRACE ON off under **Save**); No query for the SCPI command)

Parameter	Description
OFF or 0	Does not save the memory trace arrays.
ON or 1	Saves the memory trace arrays.

- Query Response

```
{0|1} <new line><END>
```

- Equivalent SCPI Command

```
SAVMTRCL{OFF|0} :MMEMory:STORe:ITEM:TRACe{1|2}:DELeteLMTR
SAVMTRCL{ON|1} :MMEMory:STORe:ITEM:TRACe{1|2}:SELectLMTR
```

SAVMTRCL{OFF|ON|0|1}

SAVRAW{OFF|ON|0|1}

Specifies whether or not to save the raw data arrays. (RAW ON off under **Save**); No query for the SCPI command)

Parameter	Description
OFF or 0	Does not save the raw data arrays.
ON or 1	Saves the raw data arrays.

■ Query Response

{0|1} <new line><END>

■ Equivalent SCPI Command

SAVRAW{OFF|0} :MMEMory:STORE:ITEM:TRACe{1|2}:DELEteLRAW

SAVRAW{ON|1} :MMEMory:STORE:ITEM:TRACe{1|2}:SELEctLRAW

SAVUCOMK

Stores the user-modified compensation kit into memory. (SAVE COMPEN KIT under **Cal**); No query; Impedance analyzer only)

■ Equivalent SCPI Command

:SENSe:CORRection2:CKIT:MODifySAVE

SAVUFIXT

Saves the settings of user defined fixture. (SAVE USER FXTR KIT under **Meas** FIXTURE); No query; Impedance analyzer only)

■ Equivalent SCPI Command

:SYSTem:FIXTure:SAVE

SCACL{OFF|ON|0|1}

Couples or uncouples the "DATA" and "MEMORY" traces to be scaled. (D&M SCALE [] under **Scale Ref**); Query)

Parameter	Description
OFF or 0	Uncouples the "DATA" and "MEMORY" traces.
ON or 1	Couples the "DATA" and "MEMORY" traces.

■ Query Response

{0|1} <new line><END>

■ Equivalent SCPI Command

:DISPlay[:WINDow]:TRACe{[1]|2}:Y[:SCALE]:COUPlE{OFF|ON|0|1}

(TRACe[1] for the data trace; TRACe2 for the memory trace.)

SCAF{DATA|MEMO}

Selects one of the "DATA" or "MEMORY" traces to be scaled. (SCALE FOR [] under **Scale Ref**);
No equivalent SCPI command)

■ Query Response

{DATA|MEMO} <new line><END>

SCAL<numeric>

Sets the response value scale per graticule trace. (SCALE/DIV under **Scale Ref**)

Parameter	Range	Unit
<numeric>	0.001 to 500	(Log mag format)
	0.01 to 500	(Phase format)
	1×10^{-14} to 10	(Delay format)
	1×10^{-11} to 10000	(Smith chart, Admittance chart, Polar, Lin mag, Real, Imaginary, SWR, Expanded phase formats)
	0.1 to 20	(dBm, dB μ V, dBV formats)
	1×10^{-14} to 0.1	(Watt format)
	1×10^{-7} to 1	(Volt format)

■ Query Response

{numeric} <new line><END>

■ Equivalent SCPI Command

:DISPlay[:WINDow]:TRACe{[1]|2}:Y[:SCALE]:PDIVision<numeric>

(TRACe[1] for the data trace; TRACe2 for the memory trace.)

SCAP{FULL|UGRT|LGRT}

Selects the scale size for plotting. (SCALE: FULL, UPPER GRATICULE, LOWER GRATICULE under **Copy**)

Parameter	Description
FULL	Normal full size
UGRT	Upper graticule to the user-defined P1 and P2
LGRT	Lower graticule to the user-defined P1 and P2

■ Query Response

{FULL|UGRT|LGRT} <new line><END>

■ Equivalent SCPI Command

SCAPFULL :HCOPY:PAGE:SCALE{1|FULL}

SCAPUGRT :HCOPY:PAGE:SCALEUPPer

SCAPLGRT :HCOPY:PAGE:SCALELOWer

SCAP \square {FULL|UGRT|LGRT}

SCRN \square {OFF|ON|0|1}

Controls whether the CRT display is visible or not. (No equivalent SCPI command)

Parameter	Description
OFF or 0	Invisible (only softkey labels are displayed.)
ON or 1	Visible

■ Query Response

{0|1} <new line><END>

SDEL

Deletes a segment from a list sweep table. (DELETE under **Sweep**); No query)

■ Equivalent SCPI Command

:SENSe:LIST:SEGment:DELeTe

SDON

Saves the modified segment of a list sweep table. (SEGMENT DONE under **Sweep**); No query)

■ Equivalent SCPI Command

:SENSe:LIST:SEGment:SAVE

■ Example

OUTPUT 717;"SDON"

OUTPUT 717;":SENS:LIST:SEG:SAVE"

SEAL

Searches the trace for the next occurrence of the target value to the left of the marker. (Network and impedance analyzer only) (SEARCH LEFT under **Search**); No query)

■ Equivalent SCPI Command

:CALCulate:EVALuate:Y:XPOSITION:LTARget

SEAM {PEAK|MAX|MIN|TARG|PKSA|PKSR|PKSL|OFF}

Selects the marker search function. (SEARCH: PEAK, MAX, MIN, TARGET, SEARCH: PEAKS ALL, PEAKS RIGHT, PEAKS LEFT under **Search**); No query for the SCPI command)

Parameter	Description
PEAK	Peak search
MAX	Maximum search
MIN	Minimum search
TARG	Target search (Network and impedance analyzer only)
PKSA	Peak all
PKSR	Peak right all
PKSL	Peak left all
OFF	Marker search function OFF

- Query Response

{PEAK|MAX|MIN|TARG|PKSA|PKSR|PKSL|OFF} <new line><END>

- Equivalent SCPI Command

```
SEAM:PEAK      :CALCulate:EVALuate:Y:XPOSition:PEAK
SEAM:MAX       :CALCulate:EVALuate:Y:XPOSition:MAXimum
SEAM:MIN       :CALCulate:EVALuate:Y:XPOSition:MINimum
SEAM:TARG      :CALCulate:EVALuate:Y:XPOSition:TARGet<numeric>
SEAM:PKSA      :CALCulate:EVALuate:Y:XPOSition:PALL
SEAM:PKSR      :CALCulate:EVALuate:Y:XPOSition:PRIGHT
SEAM:PKSL      :CALCulate:EVALuate:Y:XPOSition:PLEft
SEAM:OFF       None
```

Parameter	Range
<numeric> for :CALC:EVAL:Y:XPOS:TARG	-5×10^5 to 5×10^5

- Example

```
OUTPUT 717;"SEAM PEAK"
OUTPUT 717;"SEAM?"
ENTER 717;A$
OUTPUT 717;":CALC:EVAL:Y:XPOS:PEAK"
```

SEANPK

Moves the marker to the next peak. (NEXT PEAK under **Search**); No query)

- Equivalent SCPI Command

```
:CALCulate:EVALuate:Y:XPOSition:NPEak
```

SEANPK

SEANPKL

Moves the marker to the peak to the left of the present marker position. (NEXT PEAK LEFT under `Search`); No query)

- Equivalent SCPI Command

:CALCulate:EVALuate:Y:XPOSITION:LPEak

SEANPKR

Moves the marker to the peak to the right of the present marker position. (NEXT PEAK RIGHT under `Search`); No query)

- Equivalent SCPI Command

:CALCulate:EVALuate:Y:XPOSITION:RPEak

SEAR

Searches the trace for the next occurrence of the target value to the right of the marker. (Network and impedance analyzer only) (SEARCH RIGHT under `Search`); No Query)

- Equivalent SCPI Command

:CALCulate:EVALuate:Y:XPOSITION:RTARget

SEARSTR

Sets the partial search range to the range between the marker and the Δ marker. (MKR \rightarrow SEARCH RNG under `Search`); No query)

- Equivalent SCPI Command

:CALCulate:EVALuate:BAND:SPAN Δ MARKer

SEARSTRL

Sets the left (lower) border of the partial search range at the current position of the marker. (MKR \rightarrow LEFT RNG under `Search`); No query)

- Equivalent SCPI Command

:CALCulate:EVALuate:BAND:STARt Δ MARKer

- Example

```
OUTPUT 717;"SEARSTRL"
```

```
OUTPUT 717;" :CALC:EVAL:BAND:STAR MARK"
```

SEARSTR

Sets the right (higher) border of the partial search range at the current position of the marker. (MKR \rightarrow RIGHT RNG under **Search**); No query

- Equivalent SCPI Command
:CALCulate:EVALuate:BAND:STOPMARKer

- Example

```
OUTPUT 717;"SEARSTR"
```

```
OUTPUT 717;":CALC:EVAL:BAND:STOP MARK"
```

SEATARG \square *<numeric>* [DB|DEG|S|OHM]

Makes the target value to the active function to enter a value and moves the marker to a specified target point on the trace. (Network and impedance analyzer only) (TARGET under **Search**)

Parameter	Range	Unit
<i><numeric></i>	-5×10^5 to 5×10^5	

- Query Response
{*numeric*} <new line><END>
- Equivalent SCPI Command
:CALCulate:EVALuate:Y:XPOSITION:TARGet \square *<numeric>*
- Example
OUTPUT 717;"SEATARG 0"

SEDI \square *<numeric>*

Determines the segment of the list sweep table to be modified. (EDIT under **Sweep**); No query for the SCPI command)

Parameter	Description
<i><numeric></i>	1 to 15

- Query Response
{*numeric*} <new line><END>
- Equivalent SCPI Command
:SENSe:LIST:SEGment:EDIT

SEDI \square *<numeric>*

SETCDATE \square *<numeric (year)>*, *<numeric (month)>*, *<numeric (day)>*

Sets the date of the internal clock. (**DATE MM/DD/YY** under **System**)

Parameter	Description
<i><numeric (year)></i>	1900 to 2099
<i><numeric (month)></i>	1 to 12
<i><numeric (day)></i>	1 to 31

■ Query Response

{numeric (year)} {numeric (month)} {numeric (day)} <new line><END>

■ Equivalent SCPI Command

:SYSTem:DATE \square *<numeric (year)>*, *<numeric (month)>*, *<numeric (day)>*

■ Example

OUTPUT 717;"SETCDATE 1993,1,1"

SETCTIME \square *<numeric (hour)>*, *<numeric (minute)>*, *<numeric (second)>*

Sets the time of the internal clock. (**SETCTIME** under **System**)

Parameter	Description
<i><numeric (hour)></i>	0 to 23
<i><numeric (minute)></i>	0 to 59
<i><numeric (second)></i>	0 to 59

■ Query Response

{numeric (hour)} {numeric (minute)} {numeric (second)} <new line><END>

■ Equivalent SCPI Command

:SYSTem:TIME \square *<numeric (hour)>*, *<numeric (minute)>*, *<numeric (second)>*

■ Example

OUTPUT 717;"SETCTIME 10,30,0"

SETZ \square *<numeric>* [**OHM**|**KOHM**|**MAOHM**]

Sets the characteristic impedance of the coaxial cable offset. (Network analyzer only) (**SET Z0** under **Cal**)

Parameter	Range	Unit
<i><numeric></i>	0.1 to 5×10^6	Ω

- Query Response
 {*numeric*} <new line><END>
- Equivalent SCPI Command
 :SENSe:CORRection:CIMPedanceL<*numeric*>

SGTRK{OFF|ON|0|1}

Sets the signal tracking function ON or OFF. (Spectrum analyzer only) (SGNL TRACK ON off under **Search**)

Parameter	Description
OFF or 0	Signal tracking OFF
ON or 1	Signal tracking ON

- Query Response
 {0|1} <new line><END>
- Equivalent SCPI Command
 :SENSe:TRACk:SIGNal:MARKerL{OFF|ON|0|1}

SIMFCHAR

Simulates frequency response of the equivalent circuit. (SIMULTE F-CHAR under **Display**); No query; Impedance analyzer only)

- Equivalent SCPI Command
 CALCulate:EVALuate:EPARameters:SIMulation

SING

Makes one sweep of the data and returns to the hold mode. (Instrument BASIC EXECUTE executable; SINGLE under **Trigger**); No query;

When you execute this command by EXECUTE command of the instrument BASIC, the analyzer sweeps once and then back the control to the analyzer. The program waits the completion of sweep. You can use this method instead of detecting the sweep end by monitoring the status register to synchronize the program with the analyzer.

- Equivalent SCPI Command
 :INITiate:CONTinuousL{OFF|0}
 :SENSe:SWEep:COUNT1
 :INITiate[:IMMediate]

- Example

```
OUTPUT 717;"SING"
OUTPUT 717;":INIT:CONT OFF"
OUTPUT 717;":SENS:SWE:COUN 1"
OUTPUT 717;":INIT"
EXECUTE "SING"
```

SING

SLOP{OFF|ON|0|1}

Sets the power slope function ON or OFF. With the slope ON, the output power increases with frequency (starting at the selected power level). (Network analyzer only) (SLOPE ON off under Source)

Parameter	Description
OFF or 0	Power slope function OFF
ON or 1	Power slope function ON

■ Query Response

{0|1} <new line><END>

■ Equivalent SCPI Command

:SOURce:POWer[:LEVel][:IMMediate][:AMPLitude]:SLOPe:STATe{OFF|ON|0|1}

SLOPE{<numeric>}

Compensates for the power loss versus the frequency sweep, by sloping the output power upwards proportionally to the frequency. (Network analyzer only) (SLOPE under Source)

Parameter	Range	Unit
<numeric>	0 to 2	dB/GHz

■ Query Response

{numeric} <new line><END>

■ Equivalent SCPI Command

:SOURce:POWer[:LEVel][:IMMediate][:AMPLitude]:SLOPe{<numeric>}

SMKR{1-7}{OFF|ON|0|1}

Displays the specified sub-marker at the point of the marker (ON), or erases the sub-marker (OFF). (SUB MKR {1-7} under Marker)

Parameter	Description
OFF or 0	Sub-marker ON
ON or 1	Sub-marker OFF

■ Query Response

{0|1} <new line><END>

- Equivalent SCPI Command

```

SMKR1L{OFF|ON|0|1} :DISPlay[:WINDow]:TRACe{[1]|2}:MARKer2:STATeL{OFF|ON|0|1}
SMKR2L{OFF|ON|0|1} :DISPlay[:WINDow]:TRACe{[1]|2}:MARKer3:STATeL{OFF|ON|0|1}
SMKR3L{OFF|ON|0|1} :DISPlay[:WINDow]:TRACe{[1]|2}:MARKer4:STATeL{OFF|ON|0|1}
SMKR4L{OFF|ON|0|1} :DISPlay[:WINDow]:TRACe{[1]|2}:MARKer5:STATeL{OFF|ON|0|1}
SMKR5L{OFF|ON|0|1} :DISPlay[:WINDow]:TRACe{[1]|2}:MARKer6:STATeL{OFF|ON|0|1}
SMKR6L{OFF|ON|0|1} :DISPlay[:WINDow]:TRACe{[1]|2}:MARKer7:STATeL{OFF|ON|0|1}
SMKR7L{OFF|ON|0|1} :DISPlay[:WINDow]:TRACe{[1]|2}:MARKer8:STATeL{OFF|ON|0|1}

```

(TRACe[1] for the data trace; TRACe2 for the memory trace.)

SMKRAUV{1-7}?

Outputs the auxiliary amplitude value of the measurement value at the sub-marker position. See "Marker Readout" in Appendix H for the auxiliary amplitude value of each display format.

(SUB MKR {1-7} under **Marker**; Query only)

- Query Response

{*numeric*} <new line><END>

- Equivalent SCPI Command

```

SMKRAUV1? :CALCulate:EVALuate:Y2:VALue2?
SMKRAUV2? :CALCulate:EVALuate:Y3:VALue2?
SMKRAUV3? :CALCulate:EVALuate:Y4:VALue2?
SMKRAUV4? :CALCulate:EVALuate:Y5:VALue2?
SMKRAUV5? :CALCulate:EVALuate:Y6:VALue2?
SMKRAUV6? :CALCulate:EVALuate:Y7:VALue2?
SMKRAUV7? :CALCulate:EVALuate:Y8:VALue2?

```

- Example

```

OUTPUT 717;"SMKRAUV1?"
ENTER 717;A

```

SMKRAUV{1-7}?

SMKRP{1-7}□<numeric>

Moves the sub-marker to the specified data point number.

Parameter	Description
<numeric>	1 to "number of points" (If <numeric> is 0 or less than 0, it is set to 1. If <numeric> is greater than "number of points," it is set to "number of points.")

■ Query Response

{numeric} <new line><END>

■ Equivalent SCPI Command

SMKRP1□<numeric> :CALCulate:EVALuate:Y2:XPOSITION:POINT□<numeric>
SMKRP2□<numeric> :CALCulate:EVALuate:Y3:XPOSITION:POINT□<numeric>
SMKRP3□<numeric> :CALCulate:EVALuate:Y4:XPOSITION:POINT□<numeric>
SMKRP4□<numeric> :CALCulate:EVALuate:Y5:XPOSITION:POINT□<numeric>
SMKRP5□<numeric> :CALCulate:EVALuate:Y6:XPOSITION:POINT□<numeric>
SMKRP6□<numeric> :CALCulate:EVALuate:Y7:XPOSITION:POINT□<numeric>
SMKRP7□<numeric> :CALCulate:EVALuate:Y8:XPOSITION:POINT□<numeric>

■ Example

```
OUTPUT 717;"SMKRP1 1"  
OUTPUT 717;"SMKRP1?"  
ENTER 717;A
```

SMKRPRM{1-7}□<numeric> [HZ|KHZ|MAHZ|GHZ|DBM]

Moves the sub-marker to the specified sweep parameter value. (SUB MKR {1-7} under **Marker**)

Parameter	Range	Unit
<numeric>	start value to stop value	Hz (frequency) dBm (power)

■ Query Response

{numeric} <new line><END>

■ Equivalent SCPI Command

SMKRPRM1□<numeric> :CALCulate:EVALuate:Y2:XPOSITION□<numeric>
SMKRPRM2□<numeric> :CALCulate:EVALuate:Y3:XPOSITION□<numeric>
SMKRPRM3□<numeric> :CALCulate:EVALuate:Y4:XPOSITION□<numeric>
SMKRPRM4□<numeric> :CALCulate:EVALuate:Y5:XPOSITION□<numeric>
SMKRPRM5□<numeric> :CALCulate:EVALuate:Y6:XPOSITION□<numeric>
SMKRPRM6□<numeric> :CALCulate:EVALuate:Y7:XPOSITION□<numeric>
SMKRPRM7□<numeric> :CALCulate:EVALuate:Y8:XPOSITION□<numeric>

SPAN \square *<numeric>* [**HZ**|**KHZ**|**MAHZ**|**GHZ**|**DBM**]

SMKRVAL{1-7}?

Outputs the primary part of the measurement value at the sub-marker position.
(**SUB MKR** {1-7} under **Marker**); Query only)

■ Query Response

{*numeric*} <new line><END>

■ Equivalent SCPI Command

SMKRVAL1? :CALCulate:EVALuate:Y2:VALue1?
 SMKRVAL2? :CALCulate:EVALuate:Y3:VALue1?
 SMKRVAL3? :CALCulate:EVALuate:Y4:VALue1?
 SMKRVAL4? :CALCulate:EVALuate:Y5:VALue1?
 SMKRVAL5? :CALCulate:EVALuate:Y6:VALue1?
 SMKRVAL6? :CALCulate:EVALuate:Y7:VALue1?
 SMKRVAL7? :CALCulate:EVALuate:Y8:VALue1?

SPAN \square *<numeric>* [**HZ**|**KHZ**|**MAHZ**|**GHZ**|**DBM**]

Sets the frequency span of a segment about a specified center frequency, or sets the frequency span of the list sweep table. (**SPAN**) or **SPAN** under **Sweep**)

Parameter	Range	Unit
<i><numeric></i>	0 to 1.8199 × 10 ⁹ (-1.8199 G) 0 to 20 or 30 ¹	Hz (frequency) dBm (power)

1 The maximum range depends on the center value.

■ Query Response

{*numeric*} <new line><END>

■ Equivalent SCPI Command

Span :SENSe:FREQuency:SPAN \square *<numeric>* (frequency) or
 :SOURce:POWer:SPAN *<numeric>* (power)

Span under **Sweep** :SENSe:LIST:SEGment:FREQuency:SPAN \square *<numeric>*
 (List sweep table)

2: Commands Reference

SPAN \sqcup <numeric> [HZ|KHZ|MAHZ|GHZ|DBM]

SPECFWD {M|T} \sqcup <numeric 1> [, <numeric 2> [, ... [, <numeric 7>]

Enters the standard numbers for the forward match (THRU) or forward transmission (THRU) calibration. (Network analyzer only) (FWD.MATCH, FWD.TRANS. under **Cal**); No query)

Parameter	Description
<numeric>	1 to 8

■ Equivalent SCPI Command

SPECFWDM :SENSe:CORRection:CKIT:CLASs9:STANdard \sqcup <numeric 1> [, <numeric 2> [, ... [, <numeric 7>]

SPECFWDT :SENSe:CORRection:CKIT:CLASs7:STANdard \sqcup <numeric 1> [, <numeric 2> [, ... [, <numeric 7>]

■ Example

OUTPUT 717; "SPECFWDM 1"

OUTPUT 717; ":SENS:CORR:CKIT:CLAS9:STAN 1"

SPECIMP {A|B|C} \sqcup <numeric 1> [, <numeric 2> [, ... [, <numeric 7>]

Enters the standard numbers for the first, second, or third standard class required for an impednace calibration. (SPECIFY CLASS under **Cal**); No query. Impedance analyzer only.)

Parameter	Description
<numeric>	1 to 8

■ Equivalent SCPI Command

SPECIMPA :SENSe:CORRection:CKIT:CLASs13:STANdard \sqcup <numeric 1> [, <numeric 2> [, ... [, <numeric 7>]

SPECIMPB :SENSe:CORRection:CKIT:CLASs14:STANdard \sqcup <numeric 1> [, <numeric 2> [, ... [, <numeric 7>]

SPECIMPC :SENSe:CORRection:CKIT:CLASs15:STANdard \sqcup <numeric 1> [, <numeric 2> [, ... [, <numeric 7>]

SPECS11{A|B|C}□<numeric 1>[,<numeric 2>[, ... [,<numeric 7>]

SPECRES{I|P}□<numeric 1>[,<numeric 2>[, ... [,<numeric 7>]

Enters the standard numbers for a response and isolation, or a response calibration. (Network analyzer only) (RESPONSE & ISOL'N, RESPONSE under **Cal**); No query)

Parameter	Description
<numeric>	1 to 8

■ Equivalent SCPI Command

SPECRESI :SENSe:CORRection:CKIT:CLASs12:STANdard□<numeric 1>[,<numeric 2>[, ... [,<numeric 7>]

SPECRESP :SENSe:CORRection:CKIT:CLASs11:STANdard□<numeric 1>[,<numeric 2>[, ... [,<numeric 7>]

SPECREV{M|T}□<numeric 1>[,<numeric 2>[, ... [,<numeric 7>]

Enters the standard numbers for the reverse match (THRU) or reverse transmission (THRU) calibration. (Network analyzer only) (REV.MATCH, REV.TRANS. under **Cal**); No query)

Parameter	Description
<numeric>	1 to 8

■ Equivalent SCPI Command

SPECREVM :SENSe:CORRection:CKIT:CLASs10:STANdard□<numeric 1>[,<numeric 2>[, ... [,<numeric 7>]

SPECREVT :SENSe:CORRection:CKIT:CLASs8:STANdard□<numeric 1>[,<numeric 2>[, ... [,<numeric 7>] f

SPECS11{A|B|C}□<numeric 1>[,<numeric 2>[, ... [,<numeric 7>]

Enters the standard numbers for the first, second, or third standard class required for an S₁₁ 1-port calibration. (Network analyzer only) (SPECIFY: S11A, S11B, S11C under **Cal**); No query)

Parameter	Description
<numeric>	1 to 8

■ Equivalent SCPI Command

SPECS11A :SENSe:CORRection:CKIT:CLASs1:STANdard□<numeric 1>[,<numeric 2>[, ... [,<numeric 7>]

SPECS11B :SENSe:CORRection:CKIT:CLASs2:STANdard□<numeric 1>[,<numeric 2>[, ... [,<numeric 7>]

SPECS11C :SENSe:CORRection:CKIT:CLASs3:STANdard□<numeric 1>[,<numeric 2>[, ... [,<numeric 7>]

SPECS11{A|B|C}□<numeric 1>[,<numeric 2>[, ... [,<numeric 7>]

SPECS22{A|B|C}□<numeric 1>[,<numeric 2>[, ... [,<numeric 7>]

Enters the standard numbers for the first, second, or third standard class required for an S₂₂ 1-port calibration. (Network analyzer only) (SPECIFY: S22A, S22B, S22C under **Cal**); No query)

Parameter	Description
<numeric>	1 to 8

■ Equivalent SCPI Command

SPECS22A :SENSe:CORRection:CKIT:CLASs4:STANdard□<numeric 1>[,<numeric 2>[, ... [,<numeric 7>]

SPECS22B :SENSe:CORRection:CKIT:CLASs5:STANdard□<numeric 1>[,<numeric 2>[, ... [,<numeric 7>]

SPECS22C :SENSe:CORRection:CKIT:CLASs6:STANdard□<numeric 1>[,<numeric 2>[, ... [,<numeric 7>]

SPLD□{OFF|ON|0|1}

Sets the dual channel display mode. (**SPLIT DISP ON off** under **Display**)

Parameter	Description
OFF or 0	Full-screen single graticule display
ON or 1	Split display with two half-screen graticules

■ Query Response

{0|1} <new line><END>

■ Equivalent SCPI Command

SPLD□{OFF|0} :DISPlay[:WINDow]:FORMat□FBACK

SPLD□{ON|1} :DISPlay[:WINDow]:FORMat□LULOWer

SQUI

Terminates editing a segment of the list sweep table. (**SEGMENT QUIT** under **Sweep**); No query)

■ Equivalent SCPI Command

:SENSe:LIST:SEGMENT:QUIT

STAN{A-G}

Measures the calibration standard in the current standard class. (Network analyzer only)
 (OPEN, SHORT, THRU, OPEN [], SHORT [], defined std {1-7} under **Cal**); No query)

- Equivalent SCPI Command

```

STANA      :SENSe:CORRection:COLLect[:ACQuire]LSTANdard1
STANB      :SENSe:CORRection:COLLect[:ACQuire]LSTANdard2
STANC      :SENSe:CORRection:COLLect[:ACQuire]LSTANdard3
STAND      :SENSe:CORRection:COLLect[:ACQuire]LSTANdard4
STANE      :SENSe:CORRection:COLLect[:ACQuire]LSTANdard5
STANF      :SENSe:CORRection:COLLect[:ACQuire]LSTANdard6
STANG      :SENSe:CORRection:COLLect[:ACQuire]LSTANdard7
  
```

STAR <numeric> [HZ|KHZ|MAHZ|GHZ|DBM]

Sets the start value of a segment, or sets the start value of the list sweep table. (**Start**) or **SEGMENT: START** under **Sweep**)

Parameter	Range	Unit
<numeric>	100000 (-100 k) to 1.82×10^9 (-1.82 G) (Network analyzer) 0 to 1.82×10^9 (-1.82 G) (Spectrum analyzer) -70 to 20	Hz (frequency) dBm (power)

- Query Response

{numeric} <new line><END>

- Equivalent SCPI Command

START :SENSe:FREQuency:STARt<numeric> (frequency) or
:SOURce:POWer:STARt<numeric> (power)

SEGMENT: START under **Sweep** :SENSe:LIST:SEGment:FREQuency:STARt<numeric>
 (List sweep table)

STDD

Terminates the standard definition. (Network and impedance analyzer only)
 (STD DONE (DEFINED) under **Cal**); No query)

- Equivalent SCPI Command

:SENSe:CORRection:CKIT:STANdard:SAVE

STDD

STDT \square {OPEN|SHOR|LOAD|DELA|ARBI}

Defines the standard type. (Network and impedance analyzer only) (STD TYPE: OPEN, SHORT, LOAD, DELAY/THRU, ARBITRARY IMPEDANCE under **Cal**)

Parameter	Description
OPEN	OPEN
SHOR	SHORT
LOAD	LOAD
DELA	Transmission line of specified length
ARBI	LOAD with an arbitrary impedance

■ Query Response

{OPEN|SHOR|LOAD|DELA|ARBI} <new line><END>

■ Equivalent SCPI Command

:SENSe:CORRection:CKIT:STANdard:TYPE \square {OPEN|SHORT|LOAD|DELay|AIMPedance}

STOD {DISK|MEMO}

Sets the storage device. (STOR DEV[] under **Save**); No query; No equivalent SCPI command)

Parameter	Description
STODDISK	Flexible disk drive
STODMEMO	RAM disk memory

STOP \square <numeric> [HZ|KHZ|MAHZ|GHZ|DBM]

Sets the stop value frequency of a segment, or the stop value of the list table. (**STOP**) or **STOP** under **Sweep**)

Parameter	Range	Unit
<numeric>	100000 (= 100 k) to 1.82×10^9 (= 1.82 G) (Network analyzer) 0 to 1.82×10^9 (= 1.82 G) (Spectrum analyzer) -70 to 20	Hz (frequency) dBm (power)

■ Query Response

{numeric} <new line><END>

■ Equivalent SCPI Command

Stop :SENSe:FREQuency:STOP \square <numeric> (frequency) or
:SOURce:POWer:STOP \square <numeric> (power)

Stop under **Sweep** :SENSe:LIST:SEGment:FREQuency:STOP \square <numeric>
(List sweep table)

SVCO

Saves the modified version of the color set to the non-volatile memory. (SAVE COLORS under **Display**); No query)

- Equivalent SCPI Command

:DISPlay:CMAP:STORe

SWET<numeric>[S|MS]

Sets the sweep time. (SWEEP TIME under **Sweep**)

Parameter	Range	Unit
<numeric>	(depends on the analyzer's setting)	s

- Query Response

{numeric} <new line><END>

- Equivalent SCPI Command

:SENSe:SWEep:TIME<numeric>

SWETAUTO{OFF|ON|0|1}

Sets the automatic or manual sweep time. The automatic mode gives the fastest sweep time at the analyzer's current settings of the channel. (SWEEP TIME AUTO man under **Sweep**)

Parameter	Description
OFF or 0	Manual sweep time
ON or 1	Automatic sweep time

- Query Response

{0|1} <new line><END>

- Equivalent SCPI Command

:SENSe:SWEep:TIME:AUTO{OFF|ON|0|1}

SWPT{LIN|LOGF|LIST|POWE}

Selects the sweep type. (SWEEP TYPE:LIN FREQ, LOG FREQ, LIST FREQ, POWER SWEEP under **Sweep**)

Parameter	Description
LINF	Linear frequency
LOGF	Log frequency (Network and impedance analyzer only)
LIST	Frequency list
POWE	Power (Network and impedance analyzer only)

SWPT{LINF|LOGF|LIST|POWE}

■ Query Response

{LINF|LOGF|LIST|POWE} <new line><END>

■ Equivalent SCPI Command

```
SWPTLINF      :SENSe:FREQuency:MODELSWEep
               :SOURce:POWer:MODELFIxed
               :SENSe:SWEep:SPACingLLINear

SWPTLOGF      :SENSe:FREQuency:MODELSWEep
               :SOURce:POWer:MODELFIxed
               :SENSe:SWEep:SPACingLLOGarithmic

SWPTLIST      :SENSe:FREQuency:MODELLIST
               :SOURce:POWer:MODELLIST
               :SENSe:SWEep:SPACingLLINear

SWPTPOWE      :SENSe:FREQuency:MODELFIxed
               :SOURce:POWer:MODELSWEep
               :SENSe:SWEep:SPACingLLINear
```

TARL?

Searches for the point having the parameter-specified value leftward from the right end of the range, and returns its stimulus. See "TARL?" in Appendix I for details, query response, and examples. (Instrument BASIC EXECUTE executable; No equivalent SCPI command; Query only; Network and spectrum analyzer only)

TARR?

Searches for the point having the parameter-specified value rightward from the left end of the range, and returns its stimulus. See "TARR?" in Appendix I for details, query response, and examples. (Instrument BASIC EXECUTE executable; No equivalent SCPI command; Query only; Network and spectrum analyzer only)

TERI<numeric>[OHM|KOHM]

Specifies the (arbitrary) impedance of the standard. (Network and impedance analyzer only) (TERMINAL IMPEDANCE under Cal); No query)

Parameter	Range	Unit
<numeric>	0 to 10000 (= 10 k)	Ω

■ Equivalent SCPI Command

```
:SENSe:CORRection:CKIT:STANdard:TIMPedance<numeric>
```

TESS?

Outputs the test set identifier. (Network analyzer only) (Query only)

- Query Response

{0|1} <new line><END>

Parameter	Description
0	None
1	S-parameter test set

- Equivalent SCPI Command

:SYSTem:COMMunicate:TSET?

THRR□<numeric>

Sets threshold ripple height for waveform analysis commands. See "THRR" in Appendix I for details, query response, and examples. (Instrument BASIC EXECUTE executable; No equivalent SCPI command; Query only; Network and spectrum analyzer only)

TINT□<numeric>

Adjusts the hue of the specified display element. (TINT under **Display**); No equivalent SCPI command)

Parameter	Range	Unit
<numeric>	0 to 100	%

- Query Response

{numeric} <new line><END>

TINT \square *<numeric>*

TITL \square *<string>*

Sends the string to the title area on the display. (**TITLE** under **Display**)

Parameter	Description
<i><string></i>	up to 53 characters

■ Query Response

{string} \langle new line \rangle \langle END \rangle

■ Equivalent SCPI Command

:DISPlay[:WINDow]:TEXT17[:DATA] \square *<string>*

■ Example

```
OUTPUT 717;"TITL ""COMMENT"""  
OUTPUT 717;"TITL?"  
ENTER 717;A$  
  
OUTPUT 717;":DISP:TEXT17 ""COMMENT"""  
OUTPUT 717;":DISP:TEXT17?"  
ENTER 717;A$
```

TOPV \square *<numeric>*

Defines the top border of the display and adjusts the scale value. (**TOP VALUE** under **Scale Ref**;
Impedance analyzer only.)

Parameter	Range	Unit
<i><numeric></i>	-1×10^9 to 1×10^9	y-axis unit

■ Query Response

<numeric> \langle new line \rangle \langle END \rangle

■ Equivalent SCPI Command

:DISPlay[:WINDow]:TRACe{1|2}:Y[:SCALE]:TOP \square *<numeric>*

TRACK \square {OFF|ON|0|1}

Sets the search tracking function ON or OFF. (**SRCH TRACK ON off** under **Search**)

■ Query Response

{0|1} \langle new line \rangle \langle END \rangle

- Equivalent SCPI Command

```
TRACK{OFF|0} :CALCulate:EVALuate:Y:XPOSITION:TRACkOFF
TRACK{ON|1}  :CALCulate:EVALuate:Y:XPOSITION:TRACk
             {MAXimum|MINimum|TARGet|PEAK|PALL|PLEft|PRIGHt}
```

Parameter	Description
MAXimum	Maximum search
MINimum	Minimum search
TARGet	Target search
PEAK	Peak search
PALL	Peaks all
PLEft	Peaks left
PRIGHt	Peaks right

TRAD

Completes the transmission calibration of the full or one-path 2-port calibration. (Network analyzer only) (TRANS: DONE under **Cal**); No query)

- Equivalent SCPI Command

```
:SENSe:CORRection:COLLect:SAVE6
```

- Example

```
OUTPUT 717;"TRAD"
OUTPUT 717;"SENS:CORR:COLL:SAVE6"
```

TRAN

Starts the transmission part of the full or one-path 2-port calibration. (Network analyzer only) (TRANSMISSION under **Cal**); No query)

- Equivalent SCPI Command

```
:SENSe:CORRection:COLLect[:ACQuire]TRAN2
```

TRGEVE{SWE|POIN}

Selects the trigger event mode. (Network and impedance analyzer only) (TRIG EVENT [] under **Trigger**)

Parameter	Description
SWE	Trigger event on sweep
POIN	Trigger event on point ¹

¹ Available only when the trigger source is the HP-IB, Manual, or External trigger.

- Query Response

```
{SWE|POIN} <new line><END>
```

- Equivalent SCPI Command

```
:TRIGger:EVENT:TYPE{SWEep|POINT}
```

TRGEVE \square {SWE|POIN}

TRGP \square {POS|NEG}

Sets the trigger signal polarity of an external signal connected to the rear panel EXT TRIGGER input. (TRIG PLRTY pos neg under **Trigger**)

Parameter	Description
POS	Positive trigger (low-to-high transition)
NEG	Negative trigger (high-to-low transition)

■ Query Response

{POS|NEG} <new line><END>

■ Equivalent SCPI Command

:TRIGger:SLOPe \square {POSitive|NEGative}

TRGS \square {INT|EXT|BUS|VID|MAN|GAT}

Selects the trigger source, which is common to both channels. (TRIGGER: [] under **Trigger**)

Parameter	Description
INT	Internal trigger
EXT	External trigger input from BNC on the rear panel
BUS	HP-IB trigger
VID	Video trigger (Spectrum analyzer only)
MAN	Manual trigger
GAT	External gate trigger (Spectrum analyzer and option 1D6 only)

■ Query Response

{INT|EXT|BUS|VID|MAN|GAT} <new line><END>

■ Equivalent SCPI Command

```
TRGS $\square$ INT      :TRIGger:SOURce $\square$ INTernal1
                 :SENSe:SWEep:GATed $\square$ {OFF|0}

TRGS $\square$ EXT      :TRIGger:SOURce $\square$ EXTernal
                 :SENSe:SWEep:GATed $\square$ {OFF|0}

TRGS $\square$ BUS      :TRIGger:SOURce $\square$ BUS
                 :SENSe:SWEep:GATed $\square$ {OFF|0}

TRGS $\square$ VID      :TRIGger:SOURce $\square$ INTernal2
                 :SENSe:SWEep:GATed $\square$ {OFF|0}

TRGS $\square$ MAN      :TRIGger:SOURce $\square$ MANual
                 :SENSe:SWEep:GATed $\square$ {OFF|0}

TRGS $\square$ GAT      :TRIGger:SOURce $\square$ EXTernal
                 :SENSe:SWEep:GATed $\square$ {ON|1}
```

VBW□<numeric>[HZ|KHZ|MAHZ]

Sets the bandwidth of the video bandwidth filter. (Spectrum analyzer only) (VIDEO BW under **Bw/Avg**)

Parameter	Description
<numeric>	RBW, RBW/3, RBW/10, RBW/30, RBW/100, and RBW/300

■ Query Response

{numeric} <new line><END>

■ Equivalent SCPI Command

:SENSe:BANDwidth[:RESolution]:AUTO□{OFF|0}
:SENSe:BANDwidth[:RESolution]□<numeric>

VBWT□{LIN|LOG}

Selects either the linear or logarithmic video filter. (VBW TYPE [LIN] or [LOG] under **Bw/Avg**)

■ Query Response

{LIN|LOG}<new line><END>

■ Equivalent SCPI Command

SENSe:BANDwidth:VIDeo:TYPE□{LIN|LOG}

■ Examples

```
OUTPUT @Hp4396;"SENS:BAND:VID:TYPE LOG"
OUTPUT @Hp4396;"SENS:BAND:VID:TYPE?"
ENTER @Hp4396;Type$
PRINT "Current VBW setting is ";Type$
```

VELOFACT□<numeric>

Enters the velocity factor used by the analyzer to calculate the equivalent electrical length. (Network and impedance analyzer only) (VELOCITY FACTOR under **Cal**)

Parameter	Range	Unit
<numeric>	0 to 10	

■ Query Response

{numeric} <new line><END>

■ Equivalent SCPI Command

:SENSe:CORRection:RVELocity□<numeric>

VIDLVL<numeric>

Sets the video trigger level. (VIDEO under Trigger)

Parameter	Range	Unit
<numeric>	0 to 100	%

■ Query Response

{numeric} <new line><END>

■ Equivalent SCPI Command

:TRIGger:LEVel<numeric>

WIDSIN

Searches for the cutoff point on the trace within the current cutoff points. (Network and impedance analyzer only; SEARCH IN under Search); No query)

■ Equivalent SCPI Command

:CALCulate:EVALuate:WIDTh:XPOSition:IN

■ Example

OUTPUT 717;"WIDSIN"

OUTPUT 717;":CALC:EVAL:WIDT:XPOS:IN"

WIDSOUT

Searches for the cutoff point on the trace outside of the current cutoff points. (Network and impedance analyzer only; SEARCH OUT under Search); No query)

■ Equivalent SCPI Command

:CALCulate:EVALuate:WIDTh:XPOSition:OUT

WIDT{OFF|ON|0|1}

Sets the bandwidth search feature ON or OFF. (Network and impedance analyzer only) (WIDTHS ON off under Search)

Parameter	Description
OFF or 0	Bandwidth search feature OFF
ON or 1	Bandwidth search feature ON (calculates the center stimulus value, bandwidth, Q, insertion loss, and cutoff point deviation from the center of a bandpass or band reject shape on the trace.)

■ Query Response

{0|1} <new line><END>

■ Equivalent SCPI Command

:CALCulate:EVALuate:WIDTh:STATeL{OFF|ON|0|1}

WIDV \square *<numeric>* [DB|DEG|S|OHM]

Sets an amplitude parameter that defines the start and stop points for a bandwidth search. (Network and impedance analyzer only) (WIDTH VALUE under [Search](#))

Parameter	Range	Unit
<i><numeric></i>	-5×10^5 to 5×10^5	

■ Query Response

{numeric} <new line><END>

■ Equivalent SCPI Command

:CALCulate:EVALuate:WIDTH:Y \square *<numeric>*

WIDVTYPE \square {DIVS2|MULS2|DIV2|FIXed}

Select Maker Width Value Type. When you use FIXed, you must specify the bandwidth value by using WIDV. (MKRVAL/ $\sqrt{2}$), MKRVAL $\times\sqrt{2}$, MKRVAL/2, or FIXED VALUE under [Search](#) WIDTH \square WIDHT VALUE. Impedance analyzer only.)

■ Query Response

{DIVS2|MULS2|DIV2|FIX}<new line><END>

■ Equivalent SCPI Command

:CALCulate:EVALuate:WIDTH:Y \square {DIVS2|MULS2|DIV2|FIXed, *<numeric>*}

■ Samples

OUTPUT @Hp4396;"WIDVTYPE DIV2"

OUTPUT @Hp4396;"WIDV ";Fix

OUTPUT @Hp4396;"WIDVTYPE FIX"

ZA

Selects the impedance analyzer mode. (IMPEDANCE ANALYZER under [Meas](#)); Impedance analyzer only.)

■ Query Response

{0|1}<new line><END>

Parameter	Description
0	Impedance analyzer mode is not selected.
1	Impedance analyzer mode is selected.

■ Equivalent SCPI Command

:INSTrument:TYPE \square ZA

ZA

ZMAPER␣<numeric>

Sets the zooming aperture value as a percentage of the span. (ZOOMING APERTURE under Marker→)

Parameter	Range	Unit
<numeric>	0.01 to 100 of SPAN	%

■ Query Response

{numeric} <new line><END>

■ Equivalent SCPI Command

:DATA[:DATA]␣MZAP,<numeric>

■ Example

```
OUTPUT 717;"ZMAPER 50"
```

```
OUTPUT 717;"ZMAPER?"
```

```
ENTER 717;A
```

```
OUTPUT 717;":DATA MZAP,50"
```

```
OUTPUT 717;":DATA? MZAP"
```

```
ENTER 717;A
```

Common Commands

*CLS

Clears the Status Byte Register, and the Event Register of the Operation Status Register, the Standard Event Status Register, and the Event Status Register B (Instrument Event Status Register). (No query)

- Example

```
OUTPUT 717; "*CLS"
```

*ESE|<numeric>

Sets the enable bits of the Standard Event Status Register.

Parameter	Description
<numeric>	0 to 255 (decimal expression of enable bits of the operation status register)

- Query Response

```
{numeric} <new line> <^END>
```

- Example

```
OUTPUT 717; "*ESE 1"
OUTPUT 717; "*ESE?"
ENTER 717;A
```

*ESR?

Returns the contents of the Standard Event Status Register. (Query only)

- Query Response

```
{numeric} <new line> <^END>
```

- Example

```
OUTPUT 717; "*ESR?"
ENTER 717;A
```

*IDN?

Returns the analyzer's ID.

- Query Response

```
{manufacturer} {model} {serial no.} {firmware rev.} <new line> <^END>
```

- Example

```
OUTPUT 717; "*IDN?"
ENTER 717;A$
```

***IDN?**

***OPC**

Tells the analyzer to set bit 0 (Operation Complete bit) in the Standard Event Status Register when it completes all pending operations.

*OPC? query places an ASCII character 1 into the analyzer's output queue when all pending operations have been completed.

■ Query Response

{1} <new line><END>

■ Example

OUTPUT 717;"*OPC"

OUTPUT 717;"*OPC?"

ENTER 717;A

***OPT?**

Queries the options installed. (Query only)

■ Query Response

{parameter} <new line><END>

Parameter	Description
(Null)	None
1C2	HP Instrument BASIC
1D6	Time-gated spectrum analysis

■ Example

OUTPUT 717;"*OPT?"

ENTER 717;A\$

***PCBL** <numeric>

Specifies the address of a controller that is temporarily passing HP-IB control to the analyzer. (Option 1C2 only; No query)

Parameter	Description
<numeric>	0 to 30

■ Example

OUTPUT 717;"*PCB 0"

***RST**

Resets the analyzer to its default values, (see Appendix D of the *Function Reference* for information on the default values), stops sweeping and taking data, and resets the HP Instrument BASIC (option 1C2 only). (No query)

■ Example

```
OUTPUT 717;"*RST"
```

***SRE** <numeric>

Sets the enable bits of the Status Byte Register.

Parameter	Description
<numeric>	0 to 255 (decimal expression of enable bits of the status byte register)

■ Query Response

```
{numeric} <new line><END>
```

■ Example

```
OUTPUT 717;"*SRE 1"
```

```
OUTPUT 717;"*SRE?"
```

```
ENTER 717;A
```

***STB?**

Reads the Status Byte Register by reading the master summary status bit. (Query only)

■ Query Response

```
{numeric} <new line><END>
```

■ Example

```
OUTPUT 717;"*STB?"
```

```
ENTER 717;A
```

***TRG**

Triggers the analyzer when the trigger mode is set to BUS trigger. (No query)

■ Example

```
OUTPUT 717;"*TRG"
```

***TRG**

***TST?**

Executes an internal self-test and returns the test result. (Query only)

■ Query Response

{*numeric*} <new line><END>

Parameter	Description
0	Pass
1	Fail

■ Example

```
OUTPUT 717;"*TST?"  
ENTER 717;A
```

***WAI**

Makes the analyzer wait until all previously sent commands are completed. (No query)

■ Example

```
OUTPUT 717;"*WAI"
```

SCPI Commands With No Equivalent Simple Command

:CALCulate:MATH1[:EXPRession]:CATalog?

Returns the available parameters that can be used with the :CALCulate:MATH1[:EXPRession]:NAME command. (Query only)

- Query Response

"OFF,YREF,YTRA,ZREF,ZTRA,INVS,MP4,MP8,MP16" <new line><END>

- Example

```
OUTPUT 717;":CALC:MATH1:CAT?"
ENTER 717;A$
```

:CALCulate:MATH2[:EXPRession]:CATalog?

Returns the available parameters that can be used with the :CALCulate:MATH2[:EXPRession]:NAME command. (Query only)

- Query Response

"ADD,SUB,DIV,OFF" <new line><END>

- Example

```
OUTPUT 717;":CALC:MATH2:CAT?"
ENTER 717;A$
```

:CALCulate:PATH?

Returns the order in which CALCulate subsystems are to be performed.

- Query Response

"MATH1,FORM,AVER,MATH2,LIM" <new line><END>

- Example

```
OUTPUT 717;":CALC:PATH?"
ENTER 717;A$
```

:PROG:CATalog?

Returns all the defined program names. The program name is always "PROG", because the analyzer's HP Instrument BASIC only executes a single program at a time. This command can be used from an external controller only. (Query only)

■ Query Response

```
{ "PROG" } <new line> <^END>
```

■ Example

```
OUTPUT 717; ":PROG:CAT?"  
ENTER 717; A$
```

:PROG[:SElected]:DEFine \square *<block>*

Creates and downloads programs. The DEFine query uploads programs. This command can be used from an external controller only.

Parameter	Description
<i><block></i>	program

The *<block>* must be arbitrary block program data containing the lines of program code. The first line of *<block>* must be a header, which shows the program size. There are two formats for the header as follows:

- #0 Allows the OUTPUT statement to send program line until END is specified in the OUTPUT statement.
- #NMM... M Specifies the program size.
 - N specifies the number of digits that define the program size
 - M... M is program size in byte (N digits)

Each line of the program must be separated by <CR> or <CR> <LF>. When the size of the *<block>* exceeds the amount of available memory in the instrument, the program lines are saved up to the point of memory overflow.

In the response to the DEFine query, the selected program and its size are returned. The selected program must be in either the paused or stopped state for the program to be uploaded. The *<block>* is uploaded as definite length arbitrary block response data. The program size is returned in the first line as the header, then program lines are returned.

:PROGRAM[:SElected]:NAME \square *<string>*

■ Example

```
OUTPUT 717;":PROG:DEF #0"
OUTPUT 717;":10 PRINT ""HELLO!""
OUTPUT 717;":20 END"
OUTPUT 717;":",END

DIM A$[100000]
OUTPUT 717;":PROG:DEF?"
ENTER 717 USING "%,2A";HEAD$ !   Gets the header.
B=VAL(HEAD$[2])                !
FOR I=1 TO B                    !
  ENTER 717 USING "%,A";HEAD$ !
NEXT I                          !
ENTER 717 USING "-K";A$        !   Gets the program.
```

:PROGRAM[:SElected]:DELeTe[:SElected]

Deletes the program in the BASIC editor of the analyzer. This command can be used from an external controller only. (No query)

■ Example

```
OUTPUT 717;":PROG:DEL"
```

:PROGRAM[:SElected]:DELeTe:ALL

Deletes the program in the BASIC editor of the analyzer. This command can be used from an external controller only. (No query)

■ Example

```
OUTPUT 717;":PROG:DEL:ALL"
```

:PROGRAM[:SElected]:EXECute \square *<string>*

Executes the program command. The program must be in either paused or stopped before the EXECute command is allowed. This command can be used from an external controller only. (No query)

Parameter	Description
<i><string></i>	Legal program command

■ Example

```
OUTPUT 717;":PROG:EXEC ""STEP""
```

:PROGRAM[:SElected]:MAlLocate \square { *<numeric>* | **DEFAult** }

Performs no function in the analyzer's HP Instrument BASIC. This command can be used from an external controller only.

:PROGRAM[:SElected]:NAME \square *<string>*

Performs no function in the analyzer's HP Instrument BASIC. This command can be used from an external controller only.

:PROGRAM[:SElected]:NAME \sqcup *<string>*

:PROGRAM[:SElected]:NUMBER \sqcup *<string>*, *<numeric 1>* [, *<numeric 2>* [, ...
[, *<numeric n>*]

Sets or queries the contents of numeric program variables and arrays in the program on the BASIC editor of the analyzer. This command can be used from an external controller only.

Parameter	Description
<i><string></i>	Name of an existing variable in the selected program (either character data or string data)
<i><numeric></i>	Variable value

■ Query Response

{numeric 1} [*{numeric 2}* [... [*{numeric n}*] ...]] \langle new line \rangle \langle END \rangle

(n is the number of the array.)

■ Example

```
OUTPUT 717;":PROG:NUMB A,1"  
OUTPUT 717;":PROG:NUMB? A"  
ENTER 717;B
```

:PROGRAM[:SElected]:STATE \sqcup {RUN|PAUSE|STOP|CONTinue}

Sets or queries the state of the program in the BASIC editor of the analyzer. The table below defines the affect of setting the state to the specified state from each of the possible current states. This command can be used from an external controller only.

Desired State	Current State		
	RUN	PAUSE	STOP
RUN	error (-221)	RUN	RUN
CONT	error (-221)	RUN	error (-221)
PAUSE	PAUSE	PAUSE	STOP
STOP	STOP	STOP	STOP

■ Query Response

{"RUN"|"PAUS"|"STOP"|"CONT"} \langle new line \rangle \langle END \rangle

■ Example

```
OUTPUT 717;":PROG:STAT ""STOP""  
OUTPUT 717;":PROG:STAT?"  
ENTER 717;A$
```

:PROGram[:SELEcted]:STRing \square *<string (varname)>*, *<string (value 1)>* [, *<string (value 2)>* [, ... [, *<string (value n)>*]]

Sets or queries the contents of string program variables and arrays in the program in the BASIC editor of the analyzer. If a string value is too long it is truncated when stored in the program's variable. This command can be used from an external controller only.

Parameter	Description
<i><string (varname)></i>	Name of an existing variable in the selected program (either character data or string data).
<i><string (value)></i>	Variable value

■ Query Response

{*string 1*} [{*string 2*} [... [{*string n*} ...]] *<new line><END>*

(n is the number of the array.)

■ Example

```
OUTPUT 717;":PROG:STR A,""HELLO""
OUTPUT 717;":PROG:STR? A"
ENTER 717;B$
```

:PROGram[:SELEcted]:WAIT

Causes no further commands or queries to be executed until the defined program exits from the RUN state. That is, the program is either stopped or paused. This command can be used from an external controller only.

■ Query Response

{1} *<new line><END>*

1 is returned when the program is either stopped or paused.

■ Example

```
OUTPUT 717;":PROG:WAIT"
OUTPUT 717;":PROG:WAIT?"
ENTER 717;A
```

Note



The following commands under the EXPLicit node perform the specified functions in the same manner as the corresponding commands under the SELEcted node. The EXPLicit commands are included in the analyzer's HP-IB commands to maintain compatibility with other SCPI instruments. Therefore, you can use either the EXPLicit or the SELEcted commands for the analyzer. However, you should select one set and use it consistently to avoid confusion.

:PROGRAM:EXPLICIT:DEFINE *PROG*, <block>

See “:PROGRAM[:SELECTED]:DEFINE<block>”.

:PROGRAM:EXPLICIT:DELETE *PROG*

See “:PROGRAM[:SELECTED]:DELETE[:SELECTED]”.

:PROGRAM:EXPLICIT:EXECUTE *PROG*, <string>

See “:PROGRAM[:SELECTED]:EXECUTE<string>”.

:PROGRAM:EXPLICIT:MALLOCATE *PROG*, {<numeric>|DEFAULT}

See “:PROGRAM[:SELECTED]:MALLOCATE{<numeric>|DEFAULT}”.

:PROGRAM:EXPLICIT:NAME *PROG*, <string>

See “:PROGRAM[:SELECTED]:NAME<string>”.

:PROGRAM:EXPLICIT:NUMBER *PROG*, <varname>, <numeric 1>
[, <numeric 2> [, ... [, <numeric n>] ...]]

See “:PROGRAM[:SELECTED]:NUMBER<string>, <numeric 1>[, <numeric 2> [, ... [, <numeric n>]”.

:PROGRAM:EXPLICIT:STATE *PROG*, {RUN|PAUSE|STOP|CONTINUE}

See “:PROGRAM[:SELECTED]:STATE{RUN|PAUSE|STOP|CONTINUE}”.

:PROGRAM:EXPLICIT:STRING *PROG*, <varname>, <string 1>[, <string 2>
[, ... [, <string n>] ...]]

See “:PROGRAM[:SELECTED]:STRING<string (varname)>, <string (value 1)>[, <string (value 2)>
[, ... [, <string (value n)>]”.

:PROGRAM:EXPLICIT:WAIT *PROG*

See “:PROGRAM[:SELECTED]:WAIT”.

:STATus:PRESet

Clears the Operational and Questionable Status Register groups. Both event and enable registers are cleared. (No query)

■ Example

```
OUTPUT 717;":STAT:PRES"
```

:STATus:QUEStionable:CONDition?

Returns the contents of the condition register of the Questionable Register group. (Query only)
The analyzer has no operation that reports an event to the questionable register.

:STATus:QUEStionable:ENABle□<numeric>

Sets or queries the enable register of the questionable register group.
The analyzer has no operation that reports an event to the questionable register.

:STATus:QUEStionable[:EVENT]?

Returns the contents of the event register of the Questionable register group. (Query only)
The analyzer has no operation that reports an event to the questionable register.

:SYSTem:VERSion?

Returns the value corresponding to the SCPI version to which the instrument complies. (Query only)

■ Query Response

```
{YYYY.V} <new line><^END>
```

Parameter	Description
YYYY	Year-version
V	Revision number for the year

■ Example

```
OUTPUT 717;":SYST:VERS?"
ENTER 717;A$
```

Service Related Commands

Note See the *Service Manual* for more information about each function.



:DIAG:EREFERENCE:STATe?

Tells whether an external frequency reference signal is connected to the rear-panel EXT REF INPUT connector. (Query only)

■ Query Response

{0|1} <new line><END>

Parameter	Description
0	The external reference is not connected.
1	The external reference is connected.

■ Example

```
OUTPUT 717;":DIAG:EREF:STAT?"  
ENTER 717;A
```

:DIAG:FREVISION?

Returns the current firmware revision information. (**FIRMWARE REVISION** under **System**); Query only)

■ Query Response

"HP4396A REVN.NN MON DD YEAR HH:MM:SS" <new line><END>

Parameter	Description
N.NN	Revision number
MON	Implementation date (month)
DD	Implementation date (date)
YEAR	Implementation date (year)
HH	Implementation time (hour)
MM	Implementation time (minute)
SS	Implementation time (second)

■ Example

```
OUTPUT 717;":DIAG:FREV?"  
ENTER 717;A$
```

:DIAG:INIT:RESult?

Returns the result of the power on test. (Query only)

■ Query Response

{PASS|FAIL} <new line><END>

■ Example

```
OUTPUT 717;":DIAG:INIT:RES?"
ENTER 717;A$
```

:DIAG:SERVice:BUS:AZERo<{OFF|ON|0|1}>

Sets the Auto Zero Switch of the Bus Measurement. (AZ SWITCH ON off under System)

■ Query Response

{0|1} <new line><END>

■ Example

```
OUTPUT 717;":DIAG:SERV:BUS:AZER ON"
OUTPUT 717;":DIAG:SERV:BUS:AZER?"
ENTER 717;A
```

:DIAG:SERVice:BUS:DC<numeric>

Selects the DC Bus Nodes of the Bus Measurement. (DC BUS [] under System)

Parameter	Description
<numeric>	0 to 26

■ Query Response

{numeric} <new line><END>

■ Example

```
OUTPUT 717;":DIAG:SERV:BUS:DC 0"
OUTPUT 717;":DIAG:SERV:BUS:DC?"
ENTER 717;A
```

:DIAG:SERVICE:BUS:DC <numeric>

:DIAG:SERVICE:BUS:FREQ <numeric>

Selects the Frequency Bus Nodes of the Bus Measurement. (**FREQ BUS []** under **System**)

Parameter	Description
<numeric>	0 to 7

■ Query Response

{numeric} <new line><END>

■ Example

```
OUTPUT 717;":DIAG:SERV:BUS:FREQ 0"  
OUTPUT 717;":DIAG:SERV:BUS:FREQ?"  
ENTER 717;A
```

:DIAG:SERVICE:BUS:STATe {OFF|ON|0|1}

Sets the Bus Measurement ON or OFF. (**BUS MEAS ON off** under **System**)

Parameter	Description
OFF or 0	Bus measurement OFF
ON or 1	Bus measurement ON

■ Query Response

{0|1} <new line><END>

■ Example

```
OUTPUT 717;":DIAG:SERV:BUS:STAT ON"  
OUTPUT 717;":DIAG:SERV:BUS:STAT?"  
ENTER 717;A
```

:DIAG:SERVICE:BUS:WAIT <numeric>

Waits starting the Bus Measurement for the specified count. (**WAIT COUNT** under **System**)

Parameter	Description
<numeric>	2 to 32767

■ Query Response

{numeric} <new line><END>

■ Example

```
OUTPUT 717;":DIAG:SERV:BUS:WAIT 2"  
OUTPUT 717;":DIAG:SERV:BUS:WAIT?"  
ENTER 717;A
```

:DIAG:SERVice:CCONstant:SOURce{OFF|ON|0|1}

:DIAG:SERVice:CCONstant:FRESponse{OFF|ON|0|1}

Sets the correction constants of the Frequency Response ON or OFF. (FRQ RSP CC ON off under **System**)

Parameter	Description
OFF or 0	Frequency response correction constant OFF
ON or 1	Frequency response correction constant ON

■ Query Response

{0|1} <new line><END>

■ Example

```
OUTPUT 717;":DIAG:SERV:CCON:FRES ON"  
OUTPUT 717;":DIAG:SERV:CCON:FRES?"  
ENTER 717;A
```

:DIAG:SERVice:CCONstant:IFGain{OFF|ON|0|1}

Sets the correction constant of the IF Gain Error ON or OFF. (IF GAIN CC ON off under **System**)

Parameter	Description
OFF or 0	IF gain error correction constant OFF
ON or 1	IF gain error correction constant ON

■ Query Response

{0|1} <new line><END>

■ Example

```
OUTPUT 717;":DIAG:SERV:CCON:IFG ON"  
OUTPUT 717;":DIAG:SERV:CCON:IFG?"  
ENTER 717;A
```

:DIAG:SERVice:CCONstant:SOURce{OFF|ON|0|1}

Sets the correction constant of the RF Output Level ON or OFF. (SOURCE CC ON off under **System**)

Parameter	Description
OFF or 0	RF output level correction constant OFF
ON or 1	RF output level correction constant ON

:DIAG:SERVice:CCONstant:SOURce{OFF|ON|0|1}

■ Query Response

{0|1} <new line><END>

■ Example

```
OUTPUT 717;":DIAG:SERV:CCON:SOUR ON"
OUTPUT 717;":DIAG:SERV:CCON:SOUR?"
ENTER 717;A
```

:DIAG:SERVice:CCONstant:XTAL{OFF|ON|0|1}

Sets the correction constant of the Crystal Filter ON or OFF. (XTAL CC ON off under **System**)

Parameter	Description
OFF or 0	Crystal filter correction constant OFF
ON or 1	Crystal filter correction constant ON

■ Query Response

{0|1} <new line><END>

■ Example

```
OUTPUT 717;":DIAG:SERV:CCON:XTAL ON"
OUTPUT 717;":DIAG:SERV:CCON:XTAL?"
ENTER 717;A
```

:DIAG:SERVice:IF:ADMX:MODE{AUTO|ALTErnate|DEG0|DEG90}

Sets the A/D Multiplexer of the A6 Receiver IF. (A/D MUX [] under **System**)

Parameter	Description
AUTO	Automatic
ALTErnate	Alternate
DEG0	0 °
DEG90	90 °

■ Query Response

{AUTO|ALT|DEG0|DEG90} <new line><END>

■ Example

```
OUTPUT 717;":DIAG:SERV:IF:ADMX:MODE AUTO"
OUTPUT 717;":DIAG:SERV:IF:ADMX:MODE?"
ENTER 717;A$
```

:DIAG:SERVice:IF:GAIN:W{AUTO|DB0|DB10}

:DIAG:SERVice:IF:BPFilter:MODE{AUTO|BW3M|BW1M|XTAL}

Sets the IF Band Pass Filter of the A6 Receiver IF. (IF BPF under **System**)

Parameter	Description
AUTO	Automatic
BW3M	3 MHz
BW1M	1 MHz
XTAL	Crystal

■ Query Response

{AUTO|BW3M|BW1M|XTAL} <new line><END>

■ Example

```
OUTPUT 717;":DIAG:SERV:IF:BPFilter:MODE AUTO"
OUTPUT 717;":DIAG:SERV:IF:BPFilter:MODE?"
ENTER 717;A$
```

:DIAG:SERVice:IF:GAIN:MODE{AUTO|MANual}

Sets the IF Gain mode of the A6 Receiver IF to Auto or Manual. Setting this mode to Manual enables setting the Gain W, Gain X, Gain Y, and Gain Z values. (IF GAIN AUTO man under **System**)

■ Query Response

{AUTO|MAN} <new line><END>

■ Example

```
OUTPUT 717;":DIAG:SERV:IF:GAIN:MODE AUTO"
OUTPUT 717;":DIAG:SERV:IF:GAIN:MODE?"
ENTER 717;A$
```

:DIAG:SERVice:IF:GAIN:W{AUTO|DB0|DB10}

Sets Gain W of the A6 Receiver IF. (GAIN W [] under **System**)

Parameter	Description
AUTO	Automatic
DB0	0 dB
DB10	10 dB

■ Query Response

{AUTO|DB0|DB10} <new line><END>

■ Example

```
OUTPUT 717;":DIAG:SERV:IF:GAIN:W AUTO"
OUTPUT 717;":DIAG:SERV:IF:GAIN:W?"
ENTER 717;A$
```

:DIAG:SERVice:IF:GAIN:W{ AUTO|DB0|DB10}

:DIAG:SERVice:IF:GAIN:X{ AUTO|DB0|DB18}

Sets Gain X of the A6 Receiver IF. (**GAIN X []** under **System**)

Parameter	Description
AUTO	Automatic
DB0	0 dB
DB18	18 dB

■ Query Response

{AUTO|DB0|DB18} <new line><END>

■ Example

```
OUTPUT 717;":DIAG:SERV:IF:GAIN:X AUTO"  
OUTPUT 717;":DIAG:SERV:IF:GAIN:X?"  
ENTER 717;A$
```

:DIAG:SERVice:IF:GAIN:Y{ AUTO|DB0|DB6|DB12|DB18}

Sets Gain Y of the A6 Receiver IF. (**GAIN Y []** under **System**)

Parameter	Description
AUTO	Automatic
DB0	0 dB
DB6	6 dB
DB12	12 dB
DB18	18 dB

■ Query Response

{AUTO|DB0|DB6|DB12|DB18} <new line><END>

■ Example

```
OUTPUT 717;":DIAG:SERV:IF:GAIN:Y AUTO"  
OUTPUT 717;":DIAG:SERV:IF:GAIN:Y?"  
ENTER 717;A$
```

:DIAG:SERvice:IF:LPFilter:MODE{AUTO|BW5K|BW15K|BW50K|BW150K|THRough}

:DIAG:SERvice:IF:GAIN:Z{AUTO|DB0|DB2|DB4|DB18}

Sets Gain Z of the A6 Receiver IF. (**GAIN Z** [] under **System**)

Parameter	Description
AUTO	Automatic
DB0	0 dB
DB2	2 dB
DB4	4 dB
DB18	18 dB

■ Query Response

{AUTO|DB0|DB2|DB4|DB18} <new line><END>

■ Example

```
OUTPUT 717;":DIAG:SERV:IF:GAIN:Z AUTO"
```

```
OUTPUT 717;":DIAG:SERV:IF:GAIN:Z?"
```

```
ENTER 717;A$
```

:DIAG:SERvice:IF:LPFilter:MODE{AUTO|BW5K|BW15K|BW50K|BW150K|THRough}

Sets the IF Low Pass Filter of the A6 Receiver IF. (**IF LPF** [] under **System**)

Parameter	Description
AUTO	Automatic
BW5K	5 kHz
BW15K	15 kHz
BW50K	50 kHz
BW150K	150 kHz
THRough	Through

■ Query Response

{AUTO|BW5K|BW15K|BW50K|BW150K|THR} <new line><END>

■ Example

```
OUTPUT 717;":DIAG:SERV:IF:LPF:MODE AUTO"
```

```
OUTPUT 717;":DIAG:SERV:IF:LPF:MODE?"
```

```
ENTER 717;A$
```

:DIAG:SERVice:IF:LPFILTER:MODE {AUTO|BW5K|BW15K|BW50K|BW150K|THROUGH}

:DIAG:SERVice:IF:RANGE:F {HIGH|LOW}

Sets Range F of the A6 Receiver IF. (RANGE F: HIGH, LOW under **System**)

■ Query Response

{HIGH|LOW} <new line><END>

■ Example

```
OUTPUT 717;":DIAG:SERV:IF:RANG:F HIGH"
```

```
OUTPUT 717;":DIAG:SERV:IF:RANG:F?"
```

```
ENTER 717;A$
```

:DIAG:SERVice:IF:RANGE:MODE {AUTO|MANUAL}

Sets the Range mode of the A6 Receiver IF to Auto or Manual. Setting this mode to Manual enables setting Range F and Range R. (IF RANGE AUTO man under **System**)

■ Query Response

{AUTO|MAN} <new line><END>

■ Example

```
OUTPUT 717;":DIAG:SERV:IF:RANG:MODE AUTO"
```

```
OUTPUT 717;":DIAG:SERV:IF:RANG:MODE?"
```

```
ENTER 717;A$
```

:DIAG:SERVice:IF:RANGE:R {HIGH|LOW}

Sets Range R of the A6 Receiver IF. (RANGE R: HIGH, LOW under **System**)

■ Query Response

{HIGH|LOW} <new line><END>

■ Example

```
OUTPUT 717;":DIAG:SERV:IF:RANG:R HIGH"
```

```
OUTPUT 717;":DIAG:SERV:IF:RANG:R?"
```

```
ENTER 717;A
```

:DIAG:SERVice:IF:SHBW:MODE {AUTO|NARROW|MIDDLE|WIDE}

Sets the Sample and Hold of the A6 Receiver IF. (S/H BW [] under **System**)

■ Query Response

{AUTO|NARR|MIDD|WIDE} <new line><END>

■ Example

```
OUTPUT 717;":DIAG:SERV:IF:SHBW:MODE AUTO"
```

```
OUTPUT 717;":DIAG:SERV:IF:SHBW:MODE?"
```

```
ENTER 717;A$
```

:DIAG:SERVice:SOURce:ALCLoop□{OPEN|CLOSE}

:DIAG:SERVice:IF:TLOCAl:MODE□{AUTO|AC|DC}

Sets the 3rd Local Oscillator of the A6 Receiver IF. (S/H BW [] under **System**)

■ Query Response

{AUTO|AC|DC} <new line><END>

■ Example

```
OUTPUT 717;":DIAG:SERV:IF:TLOC:MODE AUTO"
OUTPUT 717;":DIAG:SERV:IF:TLOC:MODE?"
ENTER 717;A$
```

:DIAG:SERVice:MODE□{ON|1}

Activates the service mode. (**SERVICE MODE** under **System**)

■ Query Response

{0|1} <new line><END>

■ Example

```
OUTPUT 717;":DIAG:SERV:MODE ON"
OUTPUT 717;":DIAG:SERV:MODE?"
ENTER 717;A
```

:DIAG:SERVice:SOURce:ALCLoop□{OPEN|CLOSE}

Sets the ALC Loop of the A3A2 ALC. (**ALC LOOP ON off** under **System**)

■ Query Response

{OPEN|CLOS}

■ Example

```
OUTPUT 717;":DIAG:SERV:SOUR:ALCL OPEN"
OUTPUT 717;":DIAG:SERV:SOUR:ALCL?"
ENTER 717;A
```

:DIAG:SERVice:SOURce:ALCLoop{OPEN|CLOSe}

:DIAG:SERVice:SOURce:ATTenuator{AUTO|DB0|DB10|DB20|DB30|DB40|DB50|DB60}

Sets the Output Attenuator of the A3A2 ALC. (**OUTPUT ATT** under **System**)

Parameter	Description
AUTO	Automatic
DB0	0 dB
DB10	10 dB
DB20	20 dB
DB30	30 dB
DB40	40 dB
DB50	50 dB
DB60	60 dB

■ Query Response

{AUTO|DB0|DB10|DB20|DB30|DB40|DB50|DB60} <new line><END>

■ Example

```
OUTPUT 717;":DIAG:SERV:SOUR:ATT AUTO"  
OUTPUT 717;":DIAG:SERV:SOUR:ATT?"  
ENTER 717;A$
```

:DIAG:SERVice:SOURce:GAIN:DAC:MODE{AUTO|MANual}

Sets the Gain DAC mode of the A3A2 ALC to Auto or Manual. Setting this mode to Manual enables setting Gain DAC value. (**GAIN DAC AUTO man** under **System**)

■ Query Response

{AUTO|MAN} <new line><END>

■ Example

```
OUTPUT 717;":DIAG:SERV:SOUR:GAIN:DAC:MODE AUTO"  
OUTPUT 717;":DIAG:SERV:SOUR:GAIN:DAC:MODE?"  
ENTER 717;A$
```

:DIAG:SERVice:SOURce:LEVel:DAC:VALue <numeric>

:DIAG:SERVice:SOURce:GAIN:DAC:VALue <numeric>

Sets the Gain DAC value of the A3A2 ALC. (**GAIN DAC VALUE** under **System**)

Parameter	Description
<numeric>	0 to 15

■ Query Response

{numeric} <new line><END>

■ Example

```
OUTPUT 717;":DIAG:SERV:SOUR:GAIN:DAC:VAL 0"  
OUTPUT 717;":DIAG:SERV:SOUR:GAIN:DAC:VAL?"  
ENTER 717;A
```

:DIAG:SERVice:SOURce:LEVel:DAC:MODE {AUTO|MANual}

Sets the Level DAC mode of the A3A2 ALC to Auto or Manual. Setting this mode to Manual enables setting the Level DAC value. (**LVL DAC AUTO man** under **System**)

■ Query Response

{AUTO|MAN}

■ Example

```
OUTPUT 717;":DIAG:SERV:SOUR:LEV:DAC:MODE AUTO"  
OUTPUT 717;":DIAG:SERV:SOUR:LEV:DAC:MODE?"  
ENTER 717;A$
```

:DIAG:SERVice:SOURce:LEVel:DAC:VALue <numeric>

Sets the Level DAC value of the A3A2 ALC. (**LVL DAC VALUE** under **System**)

Parameter	Description
<numeric>	0 to 4095

■ Query Response

{numeric} <new line><END>

■ Example

```
OUTPUT 717;":DIAG:SERV:SOUR:LEV:DAC:VAL 0"  
OUTPUT 717;":DIAG:SERV:SOUR:LEV:DAC:VAL?"  
ENTER 717;A
```

:DIAG:SERVice:SOURce:LEVel:DAC:VALue <numeric>

:DIAG:SERVice:SOURce:MODE {AUTO|MANual}

Sets the Source mode of the A3A2 ALC to Auto or Manual. Setting this mode to Manual enables setting the ALC Loop, Output attenuator, Level DAC, and Gain DAC. (SOURCE AUTO man under **System**)

■ Query Response

{AUTO|MANual} <new line><END>

■ Example

```
OUTPUT 717;":DIAG:SERV:SOUR:MODE AUTO"
```

```
OUTPUT 717;":DIAG:SERV:SOUR:MODE?"
```

```
ENTER 717;A$
```

:DIAG:SERVice:SYNThesizer:FLOCAl:MODE {AUTO|SINGle|TRIPle}

Sets the 1st Local Oscillator of the A5 Synthesizer. (1st LO OSC [] under **System**)

■ Query Response

{AUTO|SING|TRIP} <new line><END>

■ Example

```
OUTPUT 717;":DIAG:SERV:SYNT:FLOC:MODE AUTO"
```

```
OUTPUT 717;":DIAG:SERV:SYNT:FLOC:MODE?"
```

```
ENTER 717;A$
```

:DIAG:SERVice:SYNThesizer:FN:MODE {AUTO|NARRow|WIDE}

Sets the Fractional N Oscillator of the A5 Synthesizer. (FN OSC [] under **System**)

■ Query Response

{AUTO|NARR|WIDE} <new line><END>

■ Example

```
OUTPUT 717;":DIAG:SERV:SYNT:FN:MODE AUTO"
```

```
OUTPUT 717;":DIAG:SERV:SYNT:FN:MODE?"
```

```
ENTER 717;A$
```

:DIAG:SERVice:SYNThesizer:STEP:DAC:VALue□<numeric>

:DIAG:SERVice:SYNThesizer:FREQUency:OFFSet□<numeric>

Sets the Frequency Offset of the A5 Synthesizer. (FREQUENCY OFFSET under **System**)

Parameter	Description
<numeric>	-8×10 ⁹ (-8 G) to 8×10 ⁹ (8 G) Hz

■ Query Response

{numeric} <new line><END>

■ Example

```
OUTPUT 717;":DIAG:SERV:SYNT:FREQ:OFFS 0"  
OUTPUT 717;":DIAG:SERV:SYNT:FREQ:OFFS?"  
ENTER 717;A
```

:DIAG:SERVice:SYNThesizer:STEP:DAC:MODE□{AUTO|MANual}

Sets the Step DAC mode of the A5 Synthesizer to Auto or Manual. Setting this mode to Manual enables setting the Step DAC value. (STEP DAC under **System**)

■ Query Response

{AUTO|MANual} <new line><END>

■ Example

```
OUTPUT 717;":DIAG:SERV:SYNT:STEP:DAC:MODE AUTO"  
OUTPUT 717;":DIAG:SERV:SYNT:STEP:DAC:MODE?"  
ENTER 717;A$
```

:DIAG:SERVice:SYNThesizer:STEP:DAC:VALue□<numeric>

Sets the Step DAC value of the A5 Synthesizer. (DAC VALUE under **System**)

Parameter	Description
<numeric>	0 to 4095

■ Query Response

{numeric} <new line><END>

■ Example

```
OUTPUT 717;":DIAG:SERV:SYNT:STEP:DAC:VAL 0"  
OUTPUT 717;":DIAG:SERV:SYNT:STEP:DAC:VAL?"  
ENTER 717;A$
```

:DIAG:SERVice:SYNThesizer:STEP:DAC:VALue <numeric>

:DIAG:SERVice:SYNThesizer:STEP:LOOP {OPEN|CLOSE}

Sets the Step Oscillator Loop of the A5 Synthesizer. (LOOP open close under **System**)

■ Query Response

{OPEN|CLOS} <new line><END>

■ Example

```
OUTPUT 717;":DIAG:SERV:SYNT:STEP:LOOP OPEN"
OUTPUT 717;":DIAG:SERV:SYNT:STEP:LOOP?"
ENTER 717;A$
```

:DIAG:SERVice:SYNThesizer:STEP:MODE {AUTO|MANual}

Sets the Step Oscillator mode of the A5 Synthesizer to Auto or Manual. Setting this mode to Manual enables setting the Oscillator Output, Loop, Polarity, and Step DAC. (STEP OSC AUTO man under **System**)

■ Query Response

{AUTO|MAN} <new line><END>

■ Example

```
OUTPUT 717;":DIAG:SERV:SYNT:STEP:MODE AUTO"
OUTPUT 717;":DIAG:SERV:SYNT:STEP:MODE?"
ENTER 717;A$
```

:DIAG:SERVice:SYNThesizer:STEP:OUTPut {OFF|ON|0|1}

Sets the Step Oscillator Output ON or OFF of the A5 Synthesizer. (OSC OUT ON off under **System**)

■ Query Response

{0|1} <new line><END>

■ Example

```
OUTPUT 717;":DIAG:SERV:SYNT:STEP:OUTP ON"
OUTPUT 717;":DIAG:SERV:SYNT:STEP:OUTP?"
ENTER 717;A
```

:DIAG:SERVice:SYNThesizer:STEP:POLarity {AUTO|POSitive|NEGative}

Sets the Step Oscillator Polarity of the A5 Synthesizer. (POLARITY [] under **System**)

■ Query Response

{AUTO|POS|NEG} <new line><END>

■ Example

```
OUTPUT 717;":DIAG:SERV:SYNT:STEP:POL AUTO"
OUTPUT 717;":DIAG:SERV:SYNT:STEP:POL?"
ENTER 717;A$
```

:DIAG:TEST *<numeric>*

Selects the diagnostic tests. (TESTS, INTERNAL TESTS, EXTERNAL TESTS, ADJUSTMENT TESTS, DISPLAY TESTS, ALL EXT TESTS under System; No query)

Parameter	Description
0	First internal test (ALL INT).
17	First external test (FRONT PANEL DIAG).
41	First adjustment test (DC OFFST/HLD STEP).
48	First display test (TEST PATTERN 1).
63	First ALL EXT test (ALL EXT 1).
68	Miscellaneous test (IMPEDANCE TEST KIT).

■ Example

```
OUTPUT 717;":DIAG:TEST 0"
```

:DIAG:TEST:CONTInue

Continues the diagnostic test when the test is paused for user interaction. (CONTINUE under System; No query)

■ Example

```
OUTPUT 717;":DIAG:TEST:CONT"
```

:DIAG:TEST:EXECute

Runs the selected diagnostic tests. (EXECUTE TEST under System; No query)

■ Example

```
OUTPUT 717;":DIAG:TEST:EXEC"
```

:DIAG:TEST:EXECute

:DIAG:TEST:RESult? □ <numeric>

Returns the diagnostic test result. (Query only)

Parameter	Description
<numeric>	Test number; 0 to 67

■ Query Response

{ "PASS" | "FAIL" | "BUSY" | "NDON" | "DONE" } <new line> <END>

Parameter	Description
"PASS"	Pass
"FAIL"	Fail
"BUSY"	In progress
"NDON"	Not done
"DONE"	DONE

■ Example

```
OUTPUT 717; ":DIAG:TEST:RES? 0"  
ENTER 717;A$
```

Manual Changes

Introduction

This appendix contains the information required to adapt this manual to earlier versions or configurations of the analyzer than the current printing date of this manual. The information in this manual applies directly to the HP 4396A Network/Spectrum Analyzer serial number prefix listed on the title page of this manual.

Manual Changes

To adapt this manual to your HP 4396A, see Table A-1 and Table A-2, and make all the manual changes listed opposite your instrument's serial number and firmware version.

Instruments manufactured after the printing of this manual may be different from those documented in this manual. Later instrument versions will be documented in a manual changes supplement that will accompany the manual shipped with that instrument. If your instrument's serial number is not listed on the title page of this manual or in Table A-1, it may be documented in a *yellow MANUAL CHANGES* supplement.

In additions to change information, the supplement may contain information for correcting errors (Errata) in the manual. To keep this manual as current and accurate as possible, Hewlett-Packard recommends that you periodically request the latest *MANUAL CHANGES* supplement.

For information concerning serial number prefixes not listed on the title page or in the *MANUAL CHANGE* supplement, contact the nearest Hewlett-Packard office.

Turn on the line switch or execute the *IDN? command by HP-IB to confirm the firmware version. See the "*IDN?" in Chapter 2 for information on the *IDN? command.

Table A-1. Manual Changes by Serial Number

Serial Prefix or Number	Make Manual Changes
3241J	1
3343J	2

Table A-2. Manual Changes by Firmware Version

Version	Make Manual Changes
Earlier than 2.00	1
2.00 or later and earlier than 3.00	2

Change 1

If you are using the analyzer that has the earlier version of firmware revision 2.00, use the following manual change information:

- The following commands do not be support. Delete them from Chapter 2, Appendix B, and Appendix C.

Table A-3. Additional Command of Firmware Revision 2.00

ANAOCH1	INPULOAA	OUTPCERR?	RPLLHEI?
ANAOCH2	INPUOPEA	OUTPCFIL?	RPLMEA?
ANAOATA	INPUSHOA	OUTPFILT?	RPLPP?
ANAOMEMO	LMAX?	OUTPRESF?	RPLRHEI?
ANARANG	LMIN?	OUTPRESO?	RPLVAL?
ANARFULL	NEXPK?	OUTPRESR?	TARL?
EQUCPARA?	NUMLMAX?	OUTPXFIL?	TARR?
EQUCPARS?	NUMLMIN?	PEAK?	THRR
EQUCPARS4?	OUTPMAX?	PEAN?	VBW
EQUC0?	OUTPMEAN?	POLE?	VBWT
EQUM	OUTPMIN?	RPLENV?	
INPUD	OUTPMINMAX?	RPLHEI?	

- Delete the part of the description of the following command:

SING

When you execute this command by EXECUTE command of the instruemnt BASIC, the analyzer sweeps once and then back the control to the analyzer. The program waits the completion of sweep. You can use this method instead of detecting the sweep end by monitoring the status register to synchronize the program with the analyzer.

EXECUTE "SING"

- Delete Appendix I.
- Apply the manual change information of "Change 2".

Change 2

If you are using the analyzer that has the earlier version of firmware revision 3.00, use the following manual change information:

- The following commands do not be support. Delete them from Chapter 2, Appendix B, and Appendix C.

Table A-4. Additional Command of Firmware Revision 3.00

BOTV	DEFSSHOR{R L}	LABEFIX	SAVIMP
CALECPARA	DEFSLOAD{R L}	LABEIMP{A B C}	SAVUCOMK
CLASIMP{A B C}	DISECIRC	MODIFIX	SAVUFIXT
COMC{A B C}	DISECPARA	MODICOMK	SIMFCHAR
COMCDAT	EQUC	OUTPCOMC{1 2 3}?	SPECIMP{A B C}
COMKDONE	EXPP	PHAU	TOPV
COMS	FIXE	PORTZ	WIDVTYPE
COMSDONE	FIXKDONE	REFX	ZA
COMP	FIXT	REFY	
DEFEC{R1 C1 L1 C0}	INPUCOMC{1 2 3}	RESCOM	
DEFSOPEN{G C}	LABECOMK	SAVCOM	

- Delete the parameters of the following commands:

CALI IMP
 FMT LINY| LOGY| COMP
 MEAS IMAG| IPH| IRE| IIM| AMAG| APH| ARE| AIM| RCM| RCPH| RCR| RCIM| CP|
 CS| LP| LS| D| Q| RP| RS| Lp| Ls| D| Q| Rp| Rs

Serial Number

Hewlett-Packard uses a two-part, nine-character serial number that is stamped on the serial number plate (see Figure A-1) attached to the rear panel. The first four digits and the letter are the serial prefix and the last five digits are the suffix.

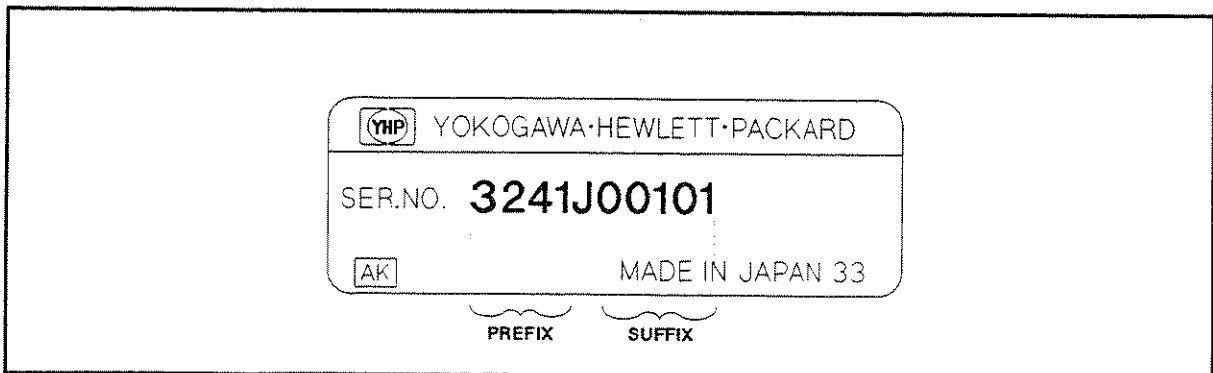

Figure A-1. Serial Number Plate

Command Summary

This appendix summarizes the HP-IB commands (and SCPI commands) according to the equivalent front panel keys as follows. It also summarizes the HP-IB only commands and the common commands.

- Ch 1
- Ch 2
- Meas
- Format
- Display
- Scale Ref
- Cal
- Sweep
- Source
- Trigger
- Start
- Stop
- Center
- Span
- Marker
- Marker→
- Search
- Utility
- System
- Local
- Copy
- Save
- Recall
- Preset
- HP-IB Only Commands

Front Panel Key	Simple Command	Equivalent SCPI Command
Ch 1	CHAN1	INSTRument[:SElect] CH1 or INSTRument:NSElect 1 INSTRument:STATe {ON 1}
Ch 2	CHAN2	INSTRument[:SElect] CH2 or INSTRument:NSElect 2 INSTRument:STATe {ON 1}
Meas		
Network Analyzer NETWORK: A/R B/R R A B CONVERSION [OFF] → See Conversion menu S-PARAMETERS → See S-parameters menu ANALYZERTYPE → See Analyzer type menu	MEAS AR MEAS BR MEAS R MEAS A MEAS B	SENSe:FUNCTion "POWer:RATIo 3,2" SENSe:FUNCTion "POWer:RATIo 4,2" SENSe:FUNCTion "POWer 2" SENSe:FUNCTion "POWer 3" SENSe:FUNCTion "POWer 4"
S-parameters menu Ref: FWD S11 [A/R] Trans:FWD S21 [B/R] Trans:REV S12 [A/R] Ref: REV S22 [B/R] CONVERSION [OFF] → See Conversion menu INPUT PORTS → See Network input port menu ANALYZER TYPE → See Analyzer type menu	MEAS S11 MEAS S21 MEAS S12 MEAS S22	SENSe:FUNCTion "POWer:S11" SENSe:FUNCTion "POWer:S21" SENSe:FUNCTion "POWer:S12" SENSe:FUNCTion "POWer:S22"
Spectrum Analyzer SPECTRUM: S R A B DETECTION [POS] → See Detection menu ANALYZER TYPE → See Analyzer type menu	MEAS S MEAS R MEAS A MEAS B	SENSe:FUNCTion "POWer 1" SENSe:FUNCTion "POWer 2" SENSe:FUNCTion "POWer 3" SENSe:FUNCTion "POWer 4"
Impedance Analyzer IMPEDANCE:MAG(--Z--) PHASE(#z) RESIST(R) REACT(X) ADMITTANCE:MAG(--Y--) PHASE(#y)	MEAS IMAG MEAS IPH MEAS IRE MEAS IIM MEAS AMAG MEAS APH	CALCulate:MATH1:NAME IMPedance CALCulate:FORMat MLNNear CALCulate:MATH1:NAME IMPedance CALCulate:FORMat PHASe CALCulate:MATH1:NAME IMPedance CALCulate:FORMat REAL CALCulate:MATH1:NAME IMPedance CALCulate:FORMat IMAGinary CALCulate:MATH1:NAME ADMittance CALCulate:FORMat MLNNear CALCulate:MATH1:NAME ADMittance CALCulate:FORMat PHASe

Front Panel Key	Simple Command	Equivalent SCPI Command
Impedance Analyzer (Continued)		
CONDUCT(G)	MEAS ARE	CALCulate:MATH1:NAME ADMittance CALCulate:FORMat REAL
SUSCEPT(B)	MEAS AIM	CALCulate:MATH1:NAME ADMittance CALCulate:FORMat IMAGinary
REFL.COEF:MAG(-Γ-)	MEAS RCM	CALCulate:MATH1:NAME OFF CALCulate:FORMat MLINear
PHASE(θ _r)	MEAS RCPH	CALCulate:MATH1:NAME OFF CALCulate:FORMat PHASe
REAL(T _x)	MEAS RCR	CALCulate:MATH1:NAME OFF CALCulate:FORMat REAL
IMAG(T _y)	MEAS RCIM	CALCulate:MATH1:NAME OFF CALCulate:FORMat IMAGinary
CAPCITNCE:PRL(C _p)	MEAS CP	CALCulate:MATH1:NAME IMPedance CALCulate:FORMat CP
SER(C _s)	MEAS CS	CALCulate:MATH1:NAME IMPedance CALCulate:FORMat CS
INDUCTNCE:PRL(L _p)	MEAS LP	CALCulate:MATH1:NAME IMPedance CALCulate:FORMat LP
SER(L _s)	MEAS LS	CALCulate:MATH1:NAME IMPedance CALCulate:FORMat LS
RESISTNCE:PRL(R _p)	MEAS RP	CALCulate:MATH1:NAME IMPedance CALCulate:FORMat RP
SER(R _s)	MEAS RS	CALCulate:MATH1:NAME IMPedance CALCulate:FORMat RS
D FACTOR	MEAS D	CALCulate:MATH1:NAME IMPedance CALCulate:FORMat D
Q FACTOR	MEAS Q	CALCulate:MATH1:NAME IMPedance CALCulate:FORMat Q
FIXTURE	MODIFIX	SYSTem:FIXTure:MODify → See Fixture menu
ANALYZER TYPE → See Analyzer type menu		
Analyzer type menu		
NETWORK ANALYZER	NA	INSTrument:TYPE NA
SPECTRUM ANALYZER	SA	INSTrument:TYPE SA
IMPEDANCE ANALYZER	ZA	INSTrument:TYPE ZA
Conversion menu		
CONVERSION OFF	CONV OFF	CALCulate:MATH1[:EXPReSSion]:NAME "OFF"
Z:Ref	CONV ZREF	CALCulate:MATH1[:EXPReSSion]:NAME "ZREF"
Z:Trans	CONV ZTRA	CALCulate:MATH1[:EXPReSSion]:NAME "ZTRA"
Y:Ref	CONV YREF	CALCulate:MATH1[:EXPReSSion]:NAME "YREF"
Y:Trans	CONV YTRA	CALCulate:MATH1[:EXPReSSion]:NAME "YTRA"
1/S	CONV ONEDS	CALCulate:MATH1[:EXPReSSion]:NAME "INVS"
MORE		
CONVERSION 4xPHASE	CONV MP4	CALCulate:MATH1[:EXPReSSion]:NAME "MP4"
8xPHASE	CONV MP8	CALCulate:MATH1[:EXPReSSion]:NAME "MP8"
16xPHASE	CONV MP16	CALCulate:MATH1[:EXPReSSion]:NAME "MP16"
RETURN		
RETURN		

Front Panel Key	Simple Command	Equivalent SCPI Command
Detection menu DETECTION POS PEAK NEG PEAK SAMPLE RETURN	DET POS DET NEG DET SAM	SENSe:DETEctor[:FUNCTION] POSitive SENSe:DETEctor[:FUNCTION] NEGative SENSe:DETEctor[:FUNCTION] SAMPlE
Fixture Menu SELECT FIXTURE FIXTURE:NONE HP16191 HP16192 HP16193 HP16194 USER RETURN SAVE USER FIXT KIT MODIFY [NONE] DEFINE EXTENSION LABEL FIXTURE KIT DONE (MODIFIED)	FIXT NONE FIXT HP16191 FIXT HP16192 FIXT HP16193 FIXT HP16194 FIXT USED SAVUFIXT MODIFX FIXE <numeric> LABEFIX <string> FIXKDONE	SYSTem:FIXTure NONE SYSTem:FIXTure HP16191 SYSTem:FIXTure HP16192 SYSTem:FIXTure HP16193 SYSTem:FIXTure HP16194 SYSTem:FIXTure UDEFined SYSTem:FIXTure:SAVE SYSTem:FIXTure:MODify SYSTem:FIXTure:DISTance <numeric> SYSTem:FIXTure:LABel <string> SYSTem:FIXTure:MODify:SAVE

Front Panel Key	Simple Command	Equivalent SCPI Command
Format Network Analyzer FORMAT:LOG MAG PHASE DELAY SMITH [Re Im] POLAR [Re Im] LIN MAG SWR MORE FORMAT:REAL IMAGINARY EXPANDED PHASE ADMITTANCE [Re Im] RETURN	FMT LOGM FMT PHAS FMT DELA FMT SMITH FMT POLA FMT LINM FMT SWR FMT REAL FMT IMAG FMT EXPP FMT ADMIT	DISPLAY[:WINDow]:TRACe:GRATICule:FORMat RECTangle CALCulate:FORMat MLOGarithmic DISPLAY[:WINDow]:TRACe:GRATICule:FORMat RECTangle CALCulate:FORMat PHASe DISPLAY[:WINDow]:TRACe:GRATICule:FORMat RECTangle CALCulate:FORMat GDELAy DISPLAY[:WINDow]:TRACe:GRATICule:FORMat SMITH CALCulate:FORMat COMPLex DISPLAY[:WINDow]:TRACe:GRATICule:FORMat POLAR CALCulate:FORMat COMPLex DISPLAY[:WINDow]:TRACe:GRATICule:FORMat RECTangle CALCulate:FORMat MLINear DISPLAY[:WINDow]:TRACe:GRATICule:FORMat RECTangle CALCulate:FORMat SWR DISPLAY[:WINDow]:TRACe:GRATICule:FORMat RECTangle CALCulate:FORMat REAL DISPLAY[:WINDow]:TRACe:GRATICule:FORMat RECTangle CALCulate:FORMat IMAGinary DISPLAY[:WINDow]:TRACe:GRATICule:FORMat RECTangle CALCulate:FORMat UPHase DISPLAY[:WINDow]:TRACe:GRATICule:FORMat ADMittance CALCulate:FORMat COMPLex
Spectrum Analyzer FORMAT:SPECTRUM NOISE UNIT: dBm dBV dBuV WATT VOLT	FMT SPECT FMT NOISE SAUNIT DBM SAUNIT DBV SAUNIT DBUV SAUNIT W SAUNIT V	SENSE:FUNCTION "POWER {1-4}" SENSE:FUNCTION "POWER{1-4}:PSDensity" CALCulate:FORMat MLOGarithmic UNIT:POWER DBM CALCulate:FORMat MLOGarithmic UNIT:POWER DBV CALCulate:FORMat MLOGarithmic UNIT:POWER DBUV CALCulate:FORMat MLINear UNIT:POWER W CALCulate:FORMat MLINear UNIT:POWER V
Impedance Analyzer FORMAT: LIN Y-AXIS LOG Y-AXIS POLAR CHART SMITH CHART ADMITTANCE CHART COMPLEX PLANE PHASE UNIT [DEG] EXP PHASE ON off EXP PHASE on OFF	FMT LINY FMT LOGY FMT POLA FMT SMITH FMT ADMIT FMT COMP PHAU {DEG RAD} EXPP ON EXPP OFF	DISPLAY[:WINDow]:TRACe:GRATICule:FORMat RECTangle DISPLAY[:WINDow]:TRACe:Y:SPACE LINear DISPLAY[:WINDow]:TRACe:GRATICule:FORMat RECTangle DISPLAY[:WINDow]:TRACe:Y:SPACE LOGarithmic DISPLAY[:WINDow]:TRACe:GRATICule:FORMat POLAR CALCulate:FORMat COMPLex DISPLAY[:WINDow]:TRACe:GRATICule:FORMat SMITH CALCulate:FORMat COMPLex DISPLAY[:WINDow]:TRACe:GRATICule:FORMat ADMittance CALCulate:FORMat COMPLex DISPLAY[:WINDow]:TRACe:GRATICule:FORMat CPLane CALCulate:FORMat:COMPLex CALCulate:FORMat:UNIT:ANGLE {DEG RAD} CALCulate:FORMat UPHase CALCulate:FORMat PHASe

Front Panel Key	Simple Command	Equivalent SCPI Command
Display		
DUAL CHAN ON off	DUAC {ON 1} DUAC {OFF 0}	INSTRument[:SElect] CH1 INSTRument:STATe {ON 1} INSTRument[:SElect] CH2 INSTRument:STATe {ON 1} INSTRument[:SElect] {CH1 CH2} INSTRument:STATe {OFF 0}
DISPLAY: DATA	DISP DATA	DISPlay[:WINDow]:TRACe1:STATe {ON 1} DISPlay[:WINDow]:TRACe2:STATe {OFF 0}
MEMORY	DISP MEMO	DISPlay[:WINDow]:TRACe2:STATe {ON 1} DISPlay[:WINDow]:TRACe1:STATe {OFF 0}
DATA & MEMORY	DISP DATM	DISPlay[:WINDow]:TRACe1:STATe {ON 1} DISPlay[:WINDow]:TRACe2:STATe {ON 1}
DATA → MEMORY	DATMEM	TRACe:COPI MTRace,DTRace
DATA HOLD [OFF]		
HOLD: OFF	DHOLD OFF	CALCulate:AVERage:STATe {OFF 0}
MAX	DHOLD MAX	CALCulate:AVERage:TYPE MAXimum CALCulate:AVERage:STATe {ON 1}
MIN	DHOLD MIN	CALCulate:AVERage:TYPE MINimum CALCulate:AVERage:STATe {ON 1}
RETURN		
DATA MATH [DATA]		
DATA MATH: DATA	MATH DATA	CALCulate:MATH2[:EXPRession]:NAME OFF
DATA-MEM	MATH DMNM	CALCulate:MATH2[:EXPRession]:NAME SUB
DATA+MEM	MATH DPLM	CALCulate:MATH2[:EXPRession]:NAME ADD
DATA/MEM	MATH DDVM	CALCulate:MATH2[:EXPRession]:NAME DIV
DEFAULT GAIN & OFS	DEFGO	DATA[:DATA] GAIN,1 DATA[:DATA] OFFS,0
OFFSET		
MKR → OFFSET	MKROFS	DATA[:DATA] OFFS,MARKer
OFFSET VALUE	DATOVAL <numeric> DATOVAL?	DATA[:DATA] OFFS,<numeric> DATA[:DATA]? OFFS
AUX OFFSET VALUE	DATAOVAL <numeric> DATAOVAL?	DATA[:DATA] AOFF,<numeric> DATA[:DATA]? AOFF
RETURN		
GAIN	DATGAIN <numeric> DATGAIN?	DATA[:DATA] GAIN,<numeric> DATA[:DATA]? GAIN
RETURN		
MORE		
SPLIT DISP ON off	SPLD {ON 1} SPLD {OFF 0}	DISPlay[:WINDow]:FORMat ULowEr DISPlay[:WINDow]:FORMat FRack
DISPLAY ALLOCATION		
ALL INSTRUMENT	DISA ALLI	DISPlay[:WINDow]:ALLocation INSTRument
HALF INSTR HALF BASIC	DISA HIHB	DISPlay[:WINDow]:ALLocation HIHB
ALL BASIC	DISA ALLB	DISPlay[:WINDow]:ALLocation BASic
BASIC STATUS	DISA BASS	DISPlay[:WINDow]:ALLocation BSTatus
RETURN		

Front Panel Key	Simple Command	Equivalent SCPI Command
EQUIV CKT MENU → See Equivalent circuit menu TITLE → See Title menu ADJUST DISPLAY → See Adjust display menu FREQUENCYBLANK RETURN	 TTTL <string> FREQO	DISPlay[:WINDow]:TEXT17[:DATA] <string> DISPlay:ANNotation:FREQUency {OFF 0} SYSTem:SECurity[:STATe] {ON 1}
Equivalent Circuit Menu SELECT EQV CKT [A] CKT A B C D E CALCULATE EQV PARAMS SIMULATE F-CHAR RETURN DISP EQUIV PARM [OFF] DISP EQUIV PARM [ON] DEFINE EQV PARAMS PARAMETER R1 C1 L1 C0 SIMULATE F-CHAR RETURN CALCULATE EQV PARAMS SIMULATE F-CHAR RETURN	EQUC CIRA EQUC CIRB EQUC CIRC EQUC CIRD EQUC CIRE CALECPARA SIMFCHAR DISECPARA OFF DISECPARA ON DEFECR1 <numeric> DEFECC1 <numeric> DEFEC1 <numeric> DEFECC0 <numeric> SIMFCHAR CALECPARA SIMFCHAR	CALCulate:EVALuate:EPARameters:CIRCUit A CALCulate:EVALuate:EPARameters:CIRCUit B CALCulate:EVALuate:EPARameters:CIRCUit C CALCulate:EVALuate:EPARameters:CIRCUit D CALCulate:EVALuate:EPARameters:CIRCUit E CALCulate:EVALuate:EPARameters DISPlay[:WINDow]:TEXT18:STATe {ON 1} CALCulate:EVALuate:EPARameters:SIMulation DISPlay[:WINDow]:TEXT18:STAT {0 OFF} DISPlay[:WINDow]:TEXT18:STAT {1 ON} DATA[:DATA] EQR1,<numeric> DATA[:DATA] EQC1,<numeric> DATA[:DATA] EQL1,<numeric> DATA[:DATA] EQC0,<numeric> CALCulate:EVALuate:EPARameters:SIMulation CALCulate:EVALuate:EPARameters CALCulate:EVALuate:EPARameters:SIMulation
Adjust display menu INTENSITY BACKGROUND INTENSITY MODIFY COLORS CH1 DATA CH1 MEM/LIMIT LINE CH2 DATA CH2 MEM/LIMIT LINE GRATICULE WARNING MORE TEXT IBASIC	INTE <numeric> BACI <numeric> COLO CH1D COLO CH1M COLO CH2D COLO CH2M COLO GRAT COLO WARN COLO TEXT COLO IBT	DISPlay:BRIGhtness <numeric> DISPlay:CONTRast <numeric> DISPlay:CMAp:COLor1:HSL <hue>,<sat>,<lum> DISPlay:CMAp:COLor2:HSL <hue>,<sat>,<lum> DISPlay:CMAp:COLor3:HSL <hue>,<sat>,<lum> DISPlay:CMAp:COLor4:HSL <hue>,<sat>,<lum> DISPlay:CMAp:COLor5:HSL <hue>,<sat>,<lum> DISPlay:CMAp:COLor6:HSL <hue>,<sat>,<lum> DISPlay:CMAp:COLor7:HSL <hue>,<sat>,<lum> DISPlay:CMAp:COLor8:HSL <hue>,<sat>,<lum>

Front Panel Key	Simple Command	Equivalent SCPI Command
Adjust display menu (Continued) MORE PEN 1 PEN 2 PEN 3 PEN 4 PEN 5 PEN 6 RETURN RETURN RETURN DEFAULT COLORS SAVE COLORS RECALL COLORS RETURN	 COLO PEN1 COLO PEN2 COLO PEN3 COLO PEN4 COLO PEN5 COLO PEN6 DEFC SVCO RECC	 DISPlay:CMAP:COLor9:HSL <hue>,<sat>,<lum> DISPlay:CMAP:COLor10:HSL <hue>,<sat>,<lum> DISPlay:CMAP:COLor11:HSL <hue>,<sat>,<lum> DISPlay:CMAP:COLor12:HSL <hue>,<sat>,<lum> DISPlay:CMAP:COLor13:HSL <hue>,<sat>,<lum> DISPlay:CMAP:COLor14:HSL <hue>,<sat>,<lum> DISPlay:CMAP:DEFault DISPlay:CMAP:STORe DISPlay:CMAP:LOAD
Color adjust menu TINT BRIGHTNESS COLOR RESET COLOR RETURN	TINT <numeric> CBRI <numeric> COLOR <numeric> RSCO	DISPlay:CMAP:COLor{1-14}:DEFault

Front Panel Key	Simple Command	Equivalent SCPI Command
Scale Ref Network Analyzer AUTO SCALE SCALE/DIV REFERENCE POSITION REFERENCE VALUE MKR→REFERENCE SCALE FOR [DATA] D&M SCALE [COUPLE] ELECTRICAL DELAY MENU MKR→DELAY ELECTRICAL DELAY PHASE OFFSET RETURN	AUTO SCAL <numeric> REFP <numeric> REFV <numeric> MKRREF SCAF DATA SCAF MEMO SCAC {OFF ON 0 1} MKRDELA ELED <numeric> PHAO <numeric>	DISPlay[:WINDow]:TRACe{1 2}:Y[:SCALe]:AUTO ONCE DISPlay[:WINDow]:TRACe{1 2}:Y[:SCALe]:PDIVision <numeric> DISPlay[:WINDow]:TRACe{1 2}:Y[:SCALe]:RPOStion <numeric> DISPlay[:WINDow]:TRACe{1 2}:Y[:SCALe]:RLEVel <numeric> DISPlay[:WINDow]:TRACe{1 2}:Y[:SCALe]:RLEVel MARKer DISPlay[:WINDow]:TRACe{1 2}:Y[:SCALe]:COUPle {OFF ON 0 1} SENSe:CORRection:EDELay2 MARKer SENSe:CORRection:EDELay2 <numeric> SENSe:CORRection:OFFSet:PHASe <numeric>
Spectrum Analyzer ATTEN AUTO man ATTEN SCALE/DIV REFERENCE VALUE MKR→REFERENCE SCALE FOR [DATA] D&M SCALE [COUPLE] MAX MIXER LEVEL	ATTAUTO {OFF ON 0 1} ATT <numeric> SCAL <numeric> REFV <numeric> MKRREF SCAF DATA SCAF MEMO SCAC {OFF ON 0 1} MAXMLEV <numeric>	SENSe:POWer:AC:ATTenuation:AUTO {OFF ON 0 1} SENSe:POWer:AC:ATTenuation:AUTO {OFF 0} SENSe:POWer:AC:ATTenuation <numeric> DISPlay[:WINDow]:TRACe{1 2}:Y[:SCALe]:PDIVision <numeric> DISPlay[:WINDow]:TRACe{1 2}:Y[:SCALe]:RLEVel <numeric> DISPlay[:WINDow]:TRACe{1 2}:Y[:SCALe]:RLEVel MARKer DISPlay[:WINDow]:TRACe{1 2}:Y[:SCALe]:COUPle {OFF ON 0 1} SENSe:POWer:AC:RANGe[:UPPer] <numeric>
Impedance Analyzer AUTO SCALE SCALE/DIV REFERENCE POSITION REFERENCE VALUE MKR→REFERENCE TOP VALUE BOTTOM VALUE MORE SCALE FOR [DATA] D&M SCALE [COUPLE] REFERENCE X VALUE REFERENCE Y VALUE RETURN	AUTO SCAL <numeric> REFP <numeric> REFV <numeric> MKRREF TOPV <numeric> BOTV <numeric> SCAF DATA SCAF MEMO SCAC {OFF ON 0 1} REFX <numeric> REFY <numeric>	DISPlay[:WINDow]:TRACe{1 2}:Y[:SCALe]:AUTO ONCE DISPlay[:WINDow]:TRACe{1 2}:Y[:SCALe]:PDIVision <numeric> DISPlay[:WINDow]:TRACe{1 2}:Y[:SCALe]:RPOStion <numeric> DISPlay[:WINDow]:TRACe{1 2}:Y[:SCALe]:RLEVel <numeric> DISPlay[:WINDow]:TRACe{1 2}:Y[:SCALe]:RLEVel MARKer DISPlay:TRACe{1 2}:Y[:SCALe]:TOP <numeric> DISPlay:TRACe{1 2}:Y[:SCALe]:BOTTom <numeric> DISPlay[:WINDow]:TRACe{1 2}:Y[:SCALe]:COUPle {OFF ON 0 1} DISPlay:TRACe{1 2}:X[:SCALe]:RLEVel <numeric> DISPlay:TRACe{1 2}:Y[:SCALe]:RLEVel <numeric>

Front Panel Key	Simple Command	Equivalent SCPI Command
Bw/Avg		
Network Analyzer	BW <numeric>	SENSe:BA NDwidth[:RESolution]:AU TO {OFF 0} SENSe:BA NDwidth[:RESolution] <numeric>
AVERAGING RESTART	AVERREST	SENSe:AVERage:CLEar
AVERAGING ON off	AVER {OFF ON 0 1}	SENSe:AVERage[:STATe] {OFF ON 0 1}
AVERAGING FACTOR	AVERFACT <numeric>	SENSe:AVERage:COUNt <numeric>
IF BW [40 kHz]	BW <numeric>	SENSe:BA NDwidth[:RESolution]:AU TO {OFF 0} SENSe:BA NDwidth[:RESolution] <numeric>
GROUP DELY APERTURE	GRODAPER <numeric>	CALCulate:GDAPerture:APERture <numeric>
Spectrum Analyzer	BW <numeric>	SENSe:BA NDwidth[:RESolution]:AU TO {OFF 0} SENSe:BA NDwidth[:RESolution] <numeric>
AVERAGING RESTART	AVERREST	SENSe:AVERage:CLEar
AVERAGING ON off	AVER {OFF ON 0 1}	SENSe:AVERage[:STATe] {OFF ON 0 1}
AVERAGING FACTOR	AVERFACT <numeric>	SENSe:AVERage:COUNt <numeric>
RES BW AUTO man	BWAUTO {OFF ON 0 1}	SENSe:BA NDwidth[:RESolution]:AU TO {OFF ON 0 1}
RES BW [3 MHz]	BW <numeric>	SENSe:BA NDwidth[:RESolution]:AU TO {OFF 0} SENSe:BA NDwidth[:RESolution] <numeric>
RBW/SPAN RATIO	BWSRAT <numeric>	SENSe:BA NDwidth[:RESolution]:RATio <numeric>
VIDEO BW	VBW <numeric>	SENSe:BA NDwidth:VIDeo <numeric>
Impedance Analyzer	BW <numeric>	SENSe:BA NDwidth[:RESolution]:AU TO {OFF 0} SENSe:BA NDwidth[:RESolution] <numeric>
AVERAGING RESTART	AVERREST	SENSe:AVERage:CLEar
AVERAGING ON off	AVER {OFF ON 0 1}	SENSe:AVERage[:STATe] {OFF ON 0 1}
AVERAGING FACTOR	AVERFACT <numeric>	SENSe:AVERage:COUNt <numeric>
IF BW [40 kHz]	BW <numeric>	SENSe:BA NDwidth[:RESolution]:AU TO {OFF 0} SENSe:BA NDwidth[:RESolution] <numeric>

Front Panel Key	Simple Command	Equivalent SCPI Command
Cal Network Analyzer CORRECTION ON off CALIBRATE MENU CALIBRATE:NONE RESPONSE → See Response menu RESPONSE & ISOL'N → See Response/isolation menu S11 1-PORT → See S11 1-port menu S22 1-PORT → See S22 1-port menu FULL 2-PORT → See Full 2-port menu ONE PATH 2-PORT → See One-path 2-port menu RESUME CAL SEQUENCE CAL KIT [7mm] CAL KIT:7mm 3.5mm N 50 ohm N 75 ohm USER KIT SAVE USER KIT MODIFY [7mm] → See Modify calkit menu RETURN MORE PORT EXTENSIONS → See Reference plane menu VELOCITY FACTOR SET Z0 RETURN	CORR {OFF ON 0 1} CALI NONE CALI RESP CALI RAI CALI S111 CALI S221 CALI FUL2 CALI ONE2 RESC CALK APC7 CALK APC35 CALK N50 CALK N75 CALK USED SAVEUSEK MODII	SENSE:CORRection[:STATe] {OFF ON 0 1} SENSE:CORRection:COLLect:METhod NONE SENSE:CORRection:COLLect:METhod RESPonse SENSE:CORRection:COLLect:METhod RAIsol SENSE:CORRection:COLLect:METhod S111 SENSE:CORRection:COLLect:METhod S221 SENSE:CORRection:COLLect:METhod TPORT SENSE:CORRection:COLLect:METhod OPTPort SENSE:CORRection:COLLect:RESume SENSE:CORRection:CKIT APC7 SENSE:CORRection:CKIT APC35 SENSE:CORRection:CKIT N50 SENSE:CORRection:CKIT N75 SENSE:CORRection:CKIT UDEFined SENSE:CORRection:CKIT:MODify:SAVE SENSE:CORRection:CKIT:MODify
Response standard menu defined std 1 defined std 2 defined std 3 defined std 4 defined std 5 defined std 6 defined std 7 DONE: RESPONSE	STANA STANB STANC STAND STANE STANF STANG RESPDONE	SENSE:CORRection:COLLect[:ACQuire] STANdard1 SENSE:CORRection:COLLect[:ACQuire] STANdard2 SENSE:CORRection:COLLect[:ACQuire] STANdard3 SENSE:CORRection:COLLect[:ACQuire] STANdard4 SENSE:CORRection:COLLect[:ACQuire] STANdard5 SENSE:CORRection:COLLect[:ACQuire] STANdard6 SENSE:CORRection:COLLect[:ACQuire] STANdard7 SENSE:CORRection:COLLect:SAVE2

Front Panel Key	Simple Command	Equivalent SCPI Command
Response/isolation menu RESPONSE ISOL'N STD DONE RESP ISOL'N CAL	RAIRESP RAISOL RAID	SENSe:CORRection:COLLect[:ACQuire] RESP SENSe:CORRection:COLLect[:ACQuire] ISOL SENSe:CORRection:COLLect:SAVE3
S11 1-port menu [S11]: OPEN SHORT LOAD DONE: 1-PORT CAL	CLASS11A CLASS11B CLASS11C SAV1	SENSe:CORRection:COLLect[:ACQuire] CS11A SENSe:CORRection:COLLect[:ACQuire] CS11B SENSe:CORRection:COLLect[:ACQuire] CS11C SENSe:CORRection:COLLect:SAVE4
S22 1-port menu [S22]: OPEN SHORT LOAD DONE: 1-PORT CAL	CLASS22A CLASS22B CLASS22C SAV1	SENSe:CORRection:COLLect[:ACQuire] CS22A SENSe:CORRection:COLLect[:ACQuire] CS22B SENSe:CORRection:COLLect[:ACQuire] CS22C SENSe:CORRection:COLLect:SAVE4
Full 2-port menu REFLECT'N [S11]: OPEN SHORT LOAD [S22]: OPEN SHORT LOAD REFLECT'N DONE TRANSMISSION FWD. TRANS. THRU FWD. MATCH THRU REV. TRANS THRU REV. MATCH THRU TRANS. DONE ISOLATION OMIT ISOLATION FWD.ISOL'N ISOL'N STD REV.ISOL'N ISOL'N STD ISOLATION DONE DONE: 2-PORT CAL	REFL CLASS11A CLASS11B CLASS11C CLASS22A CLASS22B CLASS22C REFD TRAN FWDT FWDM REVT REVM TRAD ISOL OMII FWDI REVI ISOD SAV2	SENSe:CORRection:COLLect[:ACQuire] REFL2 SENSe:CORRection:COLLect[:ACQuire] CS11A SENSe:CORRection:COLLect[:ACQuire] CS11B SENSe:CORRection:COLLect[:ACQuire] CS11C SENSe:CORRection:COLLect[:ACQuire] CS22A SENSe:CORRection:COLLect[:ACQuire] CS22B SENSe:CORRection:COLLect[:ACQuire] CS22C SENSe:CORRection:COLLect:SAVE5 SENSe:CORRection:COLLect[:ACQuire] TRAN2 SENSe:CORRection:COLLect[:ACQuire] FWDT SENSe:CORRection:COLLect[:ACQuire] FWDM SENSe:CORRection:COLLect[:ACQuire] REVT SENSe:CORRection:COLLect[:ACQuire] REVM SENSe:CORRection:COLLect:SAVE6 SENSe:CORRection:COLLect[:ACQuire] ISOL2 SENSe:CORRection:COLLect[:ACQuire] OMII SENSe:CORRection:COLLect[:ACQuire] FWDI SENSe:CORRection:COLLect[:ACQuire] REVI SENSe:CORRection:COLLect:SAVE7 SENSe:CORRection:COLLect:SAVE8

Front Panel Key	Simple Command	Equivalent SCPI Command
One-path 2-port menu REFLECT'N [S11]: OPEN SHORT LOAD REFLECT'N DONE TRANSMISSION FWD. TRANS. THRU FWD. MATCH THRU TRANS. DONE ISOLATION OMIT ISOLATION FWD.ISOL'N ISOL'N STD REV.ISOL'N ISOL'N STD ISOLATION DONE DONE: 2-PORT CAL	REFL CLASS11A CLASS11B CLASS11C REFD TRAN FWDT FWDM TRAD ISOL OMI FWDI REVI ISOD SAV2	SENSE:CORRection:COLLect[:ACQuire] REFL2 SENSE:CORRection:COLLect[:ACQuire] CS11A SENSE:CORRection:COLLect[:ACQuire] CS11B SENSE:CORRection:COLLect[:ACQuire] CS11C SENSE:CORRection:COLLect:SAVE5 SENSE:CORRection:COLLect[:ACQuire] TRAN2 SENSE:CORRection:COLLect[:ACQuire] FWDT SENSE:CORRection:COLLect[:ACQuire] FWDM SENSE:CORRection:COLLect:SAVE6 SENSE:CORRection:COLLect[:ACQuire] ISOL2 SENSE:CORRection:COLLect[:ACQuire] OMI SENSE:CORRection:COLLect[:ACQuire] FWDI SENSE:CORRection:COLLect[:ACQuire] REVI SENSE:CORRection:COLLect:SAVE7 SENSE:CORRection:COLLect:SAVE8
LOAD/OPEN/SHORT/THRU standard menu defined std 1 defined std 2 defined std 3 defined std 4 defined std 5 defined std 6 defined std 7 DONE: OPENS/SHORTS /LOADS/THRU	STANA STANB STANC STAND STANE STANF STANG DONE	SENSE:CORRection:COLLect[:ACQuire] STANdard1 SENSE:CORRection:COLLect[:ACQuire] STANdard2 SENSE:CORRection:COLLect[:ACQuire] STANdard3 SENSE:CORRection:COLLect[:ACQuire] STANdard4 SENSE:CORRection:COLLect[:ACQuire] STANdard5 SENSE:CORRection:COLLect[:ACQuire] STANdard6 SENSE:CORRection:COLLect[:ACQuire] STANdard7 SENSE:CORRection:COLLect:SAVE1
Reference plane menu EXTENSIONS ON off EXTENSION INPUT R EXTENSION INPUT A EXTENSION INPUT B EXTENSION PORT 1 EXTENSION PORT 2 RETURN	PORE {OFF ON 0 1} PORTR <numeric> PORTA <numeric> PORTB <numeric> PORT1 <numeric> PORT2 <numeric>	SENSE:CORRection:EDELay:STATe {OFF ON 0 1} SENSE:CORRection:EDELay:PORT3:TIME <numeric> SENSE:CORRection:EDELay:PORT4:TIME <numeric> SENSE:CORRection:EDELay:PORT5:TIME <numeric> SENSE:CORRection:EDELay:PORT1:TIME <numeric> SENSE:CORRection:EDELay:PORT2:TIME <numeric>

Front Panel Key	Simple Command	Equivalent SCPI Command
Modify calkit menu		
DEFINE STANDARD		
STD NO.1 [SHORT]	DEFS 0	SENSe:CORRection:CKIT:SELEct STANdard1
STD NO.2 [OPEN]	DEFS 1	SENSe:CORRection:CKIT:SELEct STANdard2
STD NO.3 [LOAD]	DEFS 2	SENSe:CORRection:CKIT:SELEct STANdard3
STD NO.4 [DEL/THRU]	DEFS 3	SENSe:CORRection:CKIT:SELEct STANdard4
STD NO.5 [LOAD]	DEFS 4	SENSe:CORRection:CKIT:SELEct STANdard5
STD NO.6 [LOAD]	DEFS 5	SENSe:CORRection:CKIT:SELEct STANdard6
STD NO.7 [SHORT]	DEFS 6	SENSe:CORRection:CKIT:SELEct STANdard7
STD NO.8 [OPEN]	DEFS 7	SENSe:CORRection:CKIT:SELEct STANdard8
SPECIFY CLASS		
SPECIFY: S11A	SPECS11A <value, ... >	SENSe:CORRection:CKIT:CLASs1:STANdard <n,n, ... >
S11B	SPECS11B <value, ... >	SENSe:CORRection:CKIT:CLASs2:STANdard <n,n, ... >
S11C	SPECS11C <value, ... >	SENSe:CORRection:CKIT:CLASs3:STANdard <n,n, ... >
SPECIFY: S22A	SPECS22A <value, ... >	SENSe:CORRection:CKIT:CLASs4:STANdard <n,n, ... >
S22B	SPECS22B <value, ... >	SENSe:CORRection:CKIT:CLASs5:STANdard <n,n, ... >
S22C	SPECS22C <value, ... >	SENSe:CORRection:CKIT:CLASs6:STANdard <n,n, ... >
MORE		
SPECIFY:FWD.TRANS.	SPECFWDT <value, ... >	SENSe:CORRection:CKIT:CLASs7:STANdard <n,n, ... >
REV.TRANS.	SPECREVT <value, ... >	SENSe:CORRection:CKIT:CLASs8:STANdard <n,n, ... >
FWD.MATCH	SPECFWD M <value, ... >	SENSe:CORRection:CKIT:CLASs9:STANdard <n,n, ... >
REV.MATCH	SPECREVM <value, ... >	SENSe:CORRection:CKIT:CLASs10:STANdard <n,n, ... >
RESPONSE	SPECRESP <value, ... >	SENSe:CORRection:CKIT:CLASs11:STANdard <n,n, ... >
RESPONSE & ISO'N	SPECRESI <value, ... >	SENSe:CORRection:CKIT:CLASs12:STANdard <n,n, ... >
CLASS DONE (SPEC'D)	CLAD	SENSe:CORRection:CKIT:SAVE CLASs
CLASS DONE (SPEC'D)	CLAD	SENSe:CORRection:CKIT:SAVE CLASs
LABEL CLASS		
LABEL: S11A	LABES11A <string>	SENSe:CORRection:CKIT:CLASs1:LABel <string>
S11B	LABES11B <string>	SENSe:CORRection:CKIT:CLASs2:LABel <string>
S11C	LABES11C <string>	SENSe:CORRection:CKIT:CLASs3:LABel <string>
LABEL: S22A	LABES22A <string>	SENSe:CORRection:CKIT:CLASs4:LABel <string>
S22B	LABES22B <string>	SENSe:CORRection:CKIT:CLASs5:LABel <string>
S22C	LABES22C <string>	SENSe:CORRection:CKIT:CLASs6:LABel <string>
MORE		
LABEL:FWD.TRANS.	LABEFWDT <string>	SENSe:CORRection:CKIT:CLASs7:LABel <string>
REV.TRANS.	LABEREVT <string>	SENSe:CORRection:CKIT:CLASs8:LABel <string>
FWD.MATCH	LABEFWDM <string>	SENSe:CORRection:CKIT:CLASs9:LABel <string>
REV.MATCH	LABEREVM <string>	SENSe:CORRection:CKIT:CLASs10:LABel <string>
RESPONSE	LABERESP <string>	SENSe:CORRection:CKIT:CLASs11:LABel <string>
RESPONSE & ISO'N	LABERESI <string>	SENSe:CORRection:CKIT:CLASs12:LABel <string>
LABEL DONE		
LABEL DONE		
LABEL KIT	LABK <string>	SENSe:CORRection:CKIT:LABel <string>
KIT DONE (MODIFIED)	KITD	SENSe:CORRection:CKIT:SAVE ALL

Front Panel Key	Simple Command	Equivalent SCPI Command
Specify offset menu OFFSET DELAY OFFSET LOSS OFFSET Z0 STD OFFSET DONE	OFSD <numeric> OFSL <numeric> OFSZ <numeric>	SENSe:CORRection:CKIT:STANdard:ODELay <numeric> SENSe:CORRection:CKIT:STANdard:OLOs <numeric> SENSe:CORRection:CKIT:STANdard:OCIMpedance <numeric>
Standard type menu STD TYPE OPEN C0 C1 C2 SPECIFY OFFSET → See Specify offset menu LABEL STD STD DONE (DEFINED) SHORT SPECIFY OFFSET → See Specify offset menu LABEL STD STD DONE (DEFINED) LOAD SPECIFY OFFSET → See Specify offset menu LABEL STD STD DONE (DEFINED) DELAY/THRU SPECIFY OFFSET → See Specify offset menu LABEL STD STD DONE (DEFINED) ARBITRARY IMPEDANCE TERMINAL IMPEDANCE SPECIFY OFFSET → See Specify offset menu LABEL STD STD/DONE(DEFINED) RETURN	STDT OPEN C0 <numeric> C1 <numeric> C2 <numeric> LABS <string> STDD STDT SHOR LABS <string> STDD STDT LOAD LABS <string> STDD STDT DELA LABS <string> STDD STDT ARBI TERI <numeric> LABS <string> STDD	SENSe:CORRection:CKIT:STANdard:TYPE OPEN SENSe:CORRection:CKIT:STANdard:C0 <numeric> SENSe:CORRection:CKIT:STANdard:C1 <numeric> SENSe:CORRection:CKIT:STANdard:C2 <numeric> SENSe:CORRection:CKIT:STANdard:LABel <string> SENSe:CORRection:CKIT:STANdard:SAVE SENSe:CORRection:CKIT:STANdard:TYPE SHORT SENSe:CORRection:CKIT:STANdard:LABel <string> SENSe:CORRection:CKIT:STANdard:SAVE SENSe:CORRection:CKIT:STANdard:TYPE LOAD SENSe:CORRection:CKIT:STANdard:LABel <string> SENSe:CORRection:CKIT:STANdard:SAVE SENSe:CORRection:CKIT:STANdard:TYPE DELAY SENSe:CORRection:CKIT:STANdard:LABel <string> SENSe:CORRection:CKIT:STANdard:SAVE SENSe:CORRection:CKIT:STANdard:TYPE AIMpedance SENSe:CORRection:CKIT:STANdard:TIMPedance <numeric> SENSe:CORRection:CKIT:STANdard:LABel <string> SENSe:CORRection:CKIT:STANdard:SAVE
Spectrum Analyzer EXECUTE LVL CAL LVL CAL DATA INPUT Z	LVLCAL LVCDT <numeric> INPZ <numeric>	CaLibration:AUTO ONCE SENSe:CORRection:OFFSet{MAGNitude} <numeric> INPut:IMPedance <numeric>

Front Panel Key	Simple Command	Equivalent SCPI Command
Impedance Analyzer		
CALIBRATE MENU	CALIMP	SENSe:CORRection:COLLect:MEthod IMP
OPEN	CLASIMPA	SENSe:CORRection:COLLect[:ACQuire] STANdard1
SHORT	CLASIMPB	SENSe:CORRection:COLLect[:ACQuire] STANdard2
LOAD	CLASIMPC	SENSe:CORRection:COLLect[:ACQuire] STANdard3
DONE:CAL	SAVIMP	SENSe:CORRection:COLLect:SAVE
RESUME CAL SEQUENCE	RESC	SENSe:CORRection:COLLect:RESume
FIXTURE COMPEN		
COMPEN MENU	COMP	SENSe:CORRection2:COLLect:MEthod IMPedance
OPEN	COMCA	SENSe:CORRection2:COLLect[:ACQuire] STANdard1
SHORT	COMCB	SENSe:CORRection2:COLLect[:ACQuire] STANdard2
LOAD	COMCC	SENSe:CORRection2:COLLect[:ACQuire] STANdard3
DONE:COMPEN	SAVCOM	SENSe:CORRection2:COLLect:SAVE
RESUME COMP SEQ	RESCOM	SENSe:CORRection2:COLLect:RESume
OPEN on OFF	COMCDATA {ON OFF}	SENSe:CORRection2:OPEN {ON OFF}1 0}
SHORT on OFF	COMCDATB {ON OFF}	SENSe:CORRection2:SHORT {ON OFF}1 0}
LOAD on OFF	COMCDATC {ON OFF}	SENSe:CORRection2:LOAD {ON OFF}1 0}
RETURN		
CAL KIT [IMP 7mm]		
CAL KIT : IMP 7mm	CALK APC7	SENSe:CORRection:CKIT APC7
3.5mm	CALK APC35	SENSe:CORRection:CKIT APC35
N 50Ω	CALK N50	SENSe:CORRection:CKIT N50
N 75Ω	CALK N75	SENSe:CORRection:CKIT N75
USER KIT	CALK USED	SENSe:CORRection:CKIT UDEFined
SAVE USER KIT	SAVEUSEK	SENSe:CORRection:CKIT:MODify:SAVE
MODIFY (IMP 7mm)	MODII	SENSe:CORRection:CKIT:MODify
DEFINE SYNADARD		
→ See Define standard menu		
SPECIFY CLASS		
SPECIFY: IMP A	SPECIMPA <numeric>	:SENSe:CORRection:CKIT:CLASs13:STANdard <num1>[,<num2>[, ... [,<num7>]]]
IMP B	SPECIMPB <numeric>	:SENSe:CORRection:CKIT:CLASs14:STANdard <num1>[,<num2>[, ... [,<num7>]]]
IMP C	SPECIMPC <numeric>	:SENSe:CORRection:CKIT:CLASs15:STANdard <num1>[,<num2>[, ... [,<num7>]]]
CLASS DONE	CLAD	SENSe:CORRection:CKIT:SAVE CLASs
LABEL CLASS		
LABEL: IMP A	LABELIMPA <string>	:SENSe:CORRection:CKIT:CLASs13:LABel <string>
IMP B	LABELIMPB <string>	:SENSe:CORRection:CKIT:CLASs14:LABel <string>
IMP C	LABELIMPC <string>	:SENSe:CORRection:CKIT:CLASs15:LABel <string>
LABEL KIT	LABK <string>	SENSe:CORRection:CKIT:LABel <string>
KIT DONE (MODIFIED)	KITD	SENSe:CORRection:CKIT:SAVE ALL
COMPEN KIT [USER]		
→ See Compensation kit menu		

Front Panel Key	Simple Command	Equivalent SCPI Command
PORT EXTENSIONS		
EXTENSION ON off	PORE {OFF ON 0 1}	SENSe:CORRection:EDELay:STATe {OFF ON 0 1}
EXTENSION VALUE	PORTZ <numeric>	SENSe:CORRection1:EDELay:PORT6[:TIME] <numeric>
VELOCITY FACTOR	VELOFACT <numeric>	SENSe:CORRection:RVELocity <numeric>
RETURN		

Front Panel Key	Simple Command	Equivalent SCPI Command
Compensation Kit Menu		
SAVE COMPEN KIT	SAVUCOMK	SENSe:CORRection2:CKIT:MODify:SAVE
MODIFY [USER]	MODICOMK	SENSe:CORRection2:CKIT:MODify
DEFINE STANDARD		
OPEN CONDUCT(G)	DEFSOPENG < numeric >	SENSe:CORRection2:CKIT:STNAdard1:G < numeric >
CAP(C)	DEFSOPENC < numeric >	SENSe:CORRection2:CKIT:STNAdard1:C < numeric >
SHORT RESIST(R)	DEFSSHORR < numeric >	SENSe:CORRection2:CKIT:STNAdard2:R < numeric >
INDUCT(L)	DEFSSHORL < numeric >	SENSe:CORRection2:CKIT:STNAdard2:L < numeric >
LOAD RESIST(R)	DEFSLOADR < numeric >	SENSe:CORRection2:CKIT:STNAdard3:R < numeric >
INDUCT(L)	DEFSLOADL < numeric >	SENSe:CORRection2:CKIT:STNAdard3:L < numeric >
STD DONE (DEFINED)	COMSDONE	SENSe:CORRection2:CKIT:STANdard:SAVE
LABEL KIT	LABECOMK < string >	SENSe:CORRection2:CKIT:LABel < string >
KIT DONE (MODIFIED)	COMKDONE	SENSe:CORRection2:CKIT:SAVE
RETURN		

Front Panel Key	Simple Command	Equivalent SCPI Command
Sweep		
Network/Impedance Analyzer		
SWEEP TIME AUTO man	SWETAUTO {OFF ON 0 1}	SENSe:SWEep:TIME:AUTO {OFF ON 0 1}
SWEEP TIME	SWET <numeric>	SENSe:SWEep:TIME <numeric>
h:m:s		
RETURN		
NUMBER OF POINTS	POIN <numeric>	SENSe:SWEep:POINts <numeric>
COUPLED CH ON off	COUC {OFF ON 0 1}	INSTRument:COUPle {OFF ON 0 1}
SWEEP TYPE MENU		
SWEEP TYPE:LIN FREQ	SWPT LINF	SENSe:FREQuency:MODE SWEep SOURce:POWer:MODE FLXed SENSe:SWEep:SPACing LINear
LOG FREQ	SWPT LOGF	SENSe:FREQuency:MODE SWEep SOURce:POWer:MODE FLXed SENSe:SWEep:SPACing LOGarithmic
LIST FREQ	SWPT LIST	SENSe:FREQuency:MODE LIST SOURce:POWer:MODE LIST SENSe:SWEep:SPACing LINear
POWER SWEEP	SWPT POWE	SENSe:FREQuency:MODE FLXed SOURce:POWer:MODE SWEep SENSe:SWEep:SPACing LINear
EDIT LIST	EDITLIST	
SEGMENT	SEDI <numeric>	SENSe:LIST:SEGment <numeric>
EDIT	SEDI [<numeric>]	SENSe:LIST:SEGment:EDIT
→ See NA/ZA segment menu		
DELETE	SDEL	SENSe:LIST:SEGment:DELeTe
ADD	SADD	SENSe:LIST:SEGment:ADD
→ See NA/ZA segment menu		
CLEAR LIST	CLEL	SENSe:LIST:CLEar
LIST DONE	EDITDONE	SENSe:LIST:SAVE
RETURN		
NA/ZA segment menu		
SEGMENT: MKR→START	MKRSTAR	SENSe:LIST:SEGment:FREQuency:STARt MARKer
MKR→STOP	MKRSTOP	SENSe:LIST:SEGment:FREQuency:STOP MARKer
NUMBER of POINTS	POIN <numeric>	SENSe:LIST:SEGment:POINts <numeric>
POWER	POWE <numeric>	SENSe:LIST:SEGment:POWer <numeric>
IF BW	BW <numeric>	SENSe:LIST:SEGment:BANDwidth <numeric>
MORE		
SEGMENT: START	STAR <numeric>	SENSe:LIST:SEGment:FREQuency:STARt <numeric>
STOP	STOP <numeric>	SENSe:LIST:SEGment:FREQuency:STOP <numeric>
CENTER	CENT <numeric>	SENSe:LIST:SEGment:FREQuency:CENTer <numeric>
SPAN	SPAN <numeric>	SENSe:LIST:SEGment:FREQuency:SPAN <numeric>
RETURN		
SEGMENT QUIT	SQUI	SENSe:LIST:SEGment:QUIT
SEGMENT DONE	SDON	SENSe:LIST:SEGment:SAVE

Front Panel Key	Simple Command	Equivalent SCPI Command
Spectrum Analyzer		
SWEEP TIME AUTO man	SWETAUTO {OFF ON 0 1}	SENSe:SWEep:TIME:AUTO {OFF ON 0 1}
SWEEP TIME h:m:s	SWET <numeric>	SENSe:SWEep:TIME <numeric>
RETURN		
SAMPLING NORMAL repet	REPTSMP {OFF ON 0 1}	SENSe:DETEctor:CONTInuous {OFF ON 0 1}
NUMBER OF POINTS	POIN <numeric>	SENSe:SWEep:POINts <numeric>
SWEEP TYPE MENU SWEEP TYPE:LIN FREQ	SWPT LINF	SENSe:FREQuency:MODE SWEep SOURce:POWer:MODE FIXed SENSe:SWEep:SPACing LINear
LIST FREQ	SWPT LIST	SENSe:FREQuency:MODE LIST SOURce:POWer:MODE LIST SENSe:SWEep:SPACing LINear
EDIT LIST	EDITLIST	
SEGMENT		SENSe:LIST:SEGMENT <numeric>
EDIT	SEDI [<numeric>]	SENSe:LIST:SEGMENT:EDIT
→ See SA segment menu		
DELETE	SDEL	SENSe:LIST:SEGMENT:DELete
ADD	SADD	SENSe:LIST:SEGMENT:ADD
→ See SA segment menu		
CLEAR LIST	CLEL	SENSe:LIST:CLEar
LIST DONE	EDITDONE	SENSe:LIST:SAVE
RETURN		
SA segment menu		
SEGMENT: MKR→START	MKRSTAR	SENSe:LIST:SEGMENT:FREQuency:STARt MARKer
MKR→STOP	MKRSTOP	SENSe:LIST:SEGMENT:FREQuency:STOP MARKer
POWER	POWE <numeric>	SENSe:LIST:SEGMENT:POWer <numeric>
RESBW	BW <numeric>	SENSe:LIST:SEGMENT:BANDwidth <numeric>
MORE		
SEGMENT: START	STAR <numeric>	SENSe:LIST:SEGMENT:FREQuency:STARt <numeric>
STOP	STOP <numeric>	SENSe:LIST:SEGMENT:FREQuency:STOP <numeric>
CENTER	CENT <numeric>	SENSe:LIST:SEGMENT:FREQuency:CENTer <numeric>
SPAN	SPAN <numeric>	SENSe:LIST:SEGMENT:FREQuency:SPAN <numeric>
RETURN		
SEGMENT DONE	SDON	SENSe:LIST:SEGMENT:SAVE

Front Panel Key	Simple Command	Equivalent SCPI Command
Source		
Network Analyzer		
POWER	POWE <numeric>	SOURce:POWer[:LEVel][:IMMediate][:AMPLitude] <numeric>
SLOPE	SLOPE <numeric>	SOURce:POWer[:LEVel][:IMMediate][:AMPLitude]:SLOPe <numeric>
SLOPE ON off	SLOP {OFF ON 0 1}	SOURce:POWer[:LEVel][:IMMediate][:AMPLitude]:SLOPe:STATe {OFF ON 0 1}
CW FREQ	CWFREQ <numeric>	SOURce:FREQuency[:CW] <numeric>
ATTENUATOR PORT 1	ATTP1 <numeric>	OUTPut:ATTenuation1 <numeric>
ATTENUATOR PORT 2	ATTP2 <numeric>	OUTPut:ATTenuation2 <numeric>
RF OUT ON off	RFO {OFF ON 0 1}	SOURce:POWer:STATe {OFF ON 0 1}
Spectrum Analyzer		
POWER	POWE <numeric>	SOURce:POWer[:LEVel][:IMMediate][:AMPLitude] <numeric>
RF OUT ON off	RFO {OFF ON 0 1}	SOURce:POWer:STATe {OFF ON 0 1}
Impedance Analyzer		
POWER	POWE <numeric>	SOURce:POWer[:LEVel][:IMMediate][:AMPLitude] <numeric>
CW FREQ	CWFREQ <numeric>	SOURce:FREQuency[:CW] <numeric>
RF OUT ON off	RFO {OFF ON 0 1}	SOURce:POWer:STATe {OFF ON 0 1}
Trigger		
SWEEP:HOLD	HOLD	INITiate:CONTInuous {OFF 0} ABORT
SINGLE	SING	INITiate:CONTInuous {OFF 0} SENSe:SWEEp:COUNT 1 INITiate[:IMMediate]
NUMBER of GROUPS	NUMG <numeric>	INITiate:CONTInuous {OFF 0} SENSe:SWEEp:COUNT <numOfGroups> INITiate[:IMMediate]
CONTINUOUS	CONT	INITiate:CONTInuous {ON 1}
TRIGGER:[FREE RUN]		
FREE RUN	TRGS INT	TRIGger:SOURce INTernal1 SENSe:SWEEp:GATed {OFF 0}
EXTERNAL	TRGS EXT	TRIGger:SOURce EXTernal SENSe:SWEEp:GATed {OFF 0}
(HP-IB)	TRGS BUS	TRIGger:SOURce BUS SENSe:SWEEp:GATed {OFF 0}
VIDEO	TRGS VID	TRIGger:SOURce INTernal2 SENSe:SWEEp:GATed {OFF 0}
	VIDLVL <numeric>	TRIGger:LEVel <numeric>
MANUAL	TRGS MAN	TRIGger:SOURce MANual SENSe:SWEEp:GATed {OFF 0}
GATE [LEVEL]	TRGS GAT	TRIGger:SOURce EXTernal SENSe:SWEEp:GATed {ON 1}
GATE CTL:LEVEL	GATCTL LEV	SENSe:SWEEp:GATed:TRIGger LEVel
EDGE	GATCTL EDG	SENSe:SWEEp:GATed:TRIGger EDGE
GATE DELAY	GATDLY <numeric>	SENSe:SWEEp:GATed:DELay <numeric>
GATE LENGTH	GATLEN <numeric>	SENSe:SWEEp:GATed:LENGth <numeric>
RETURN		
RETURN		
TRIG EVENT	TRGEVE SWE	TRIGger:EVENT:TYPE SWEEp
	TRGEVE POIN	TRIGger:EVENT:TYPE POINT
TRIG PLRTY POS neg	TRGP {POS NEG}	TRIGger:SLOPe {POSitive NEGative}
MEASURE RESTART	REST	INITiate[:IMMediate]:AGAIN:ALL

Front Panel Key	Simple Command	Equivalent SCPI Command
Start	STAR <numeric>	SENSe:FREQuency:STARt <numeric> (Frequency) or SOURce:POWer:STARt <numeric> (Power)
Stop	STOP <numeric>	SENSe:FREQuency:STOP <numeric> (Frequency) or SOURce:POWer:STOP <numeric> (Power)
Center STEP SIZE AUTO man CENTER STEP SIZE MKR→CNTR STEP MKRA→CNTR STEP MKR→CENTER MKRA→CENTER PEAK→CENTER	CENT <numeric> CNTSAUTO {OFF ON 0 1} CNTS <numeric> MKRCSTE MKRDCSTE MKRCENT MKRDCEnt PEAKCENT	SENSe:FREQuency:CENTer <numeric> (Frequency) or SOURce:POWer:CENTer <numeric> (Power) SENSe:FREQuency:CENTer:STEP[:INCRement]:AUTO {OFF ON 0 1} SENSe:FREQuency:CENTer:STEP[:INCRement] <numeric> SENSe:FREQuency:CENTer:STEP[:INCRement] MARKer SENSe:FREQuency:CENTer:STEP[:INCRement] DMARKer SENSe:FREQuency:CENTer MARKer (Frequency) or SOURce:POWer:CENTer MARKer (Power) SENSe:FREQuency:CENTer DMARKer (Frequency) or SOURce:POWer:CENTer DMARKer (Power) SENSe:FREQuency:CENTer TPEak (Frequency) or SOURce:POWer:CENTer TPEak (Power)
Span FULL SPAN ZERO SPAN MKRA→SPAN	SPAN <numeric> FULS SPAN 0 MKRDSPAN	SENSe:FREQuency:SPAN <numeric> (Frequency) or SOURce:POWer:SPAN <numeric> (Power) SENSe:FREQuency:SPAN:FULL (Frequency) or SOURce:POWer:SPAN:FULL (Power) SENSe:FREQuency:SPAN 0 (Frequency) or SOURce:POWer:SPAN 0 (Power) SENSe:FREQuency:SPAN DMARKer (Frequency) or SOURce:POWer:SPAN DMARKer (Power)

Front Panel Key	Simple Command	Equivalent SCPI Command
Marker	MKR {OFF ON 0 1}	DISPlay[:WINDow]:TRACe:MARKer:ALL:STATe {OFF ON 0 1}
Network/Impedance Analyzer SUB MKR → See Sub-marker menu CLEAR SUB MKR → See Sub-marker menu PRESET MKRS MKR ON [DATA] MKR [UNCOUPLE] MKR [CONT] ΔMODE MENU → See NA/ZA Delta mode menu	PRSMKRS MKRO DATA MKRO MEMO MKRCOUP {OFF ON 0 1} MKRCONT {OFF ON 0 1}	DISPlay[:WINDow]:TRACe:MARKer:ALL DEFault CALCulate:EVALuate:ON "DTR" CALCulate:EVALuate:ON "MTR" CALCulate:EVALuate:COUPle {OFF ON 0 1} CALCulate:EVALuate:INTerpolate {OFF ON 0 1}
Spectrum Analyzer SUB MKR → See Sub marker menu CLEAR SUB MKR → See Sub marker menu PRESET MKRS MKR ON [DATA] MKR [UNCOUPLE] ΔMODE MENU → See SA Delat mode menu	PRSMKRS MKRO DATA MKRO MEMO MKRCOUP {OFF ON 0 1}	DISPlay[:WINDow]:TRACe:MARKer:ALL DEFault CALCulate:EVALuate:ON "DTR" CALCulate:EVALuate:ON "MTR" CALCulate:EVALuate:COUPle {OFF ON 0 1}
NA/ZA Delta mode menu ΔMKR FIXED ΔMKR TRACKING ΔMKR ΔMODE OFF ΔMKR SWP PRM ΔMKR VALUE ΔMKR AUX VALUE RETURN	DMKR ON DMKR FIX DMKR TRAC DMKR OFF OUTPDMKR? DMKRPRM <numeric> DMKRVAL <numeric> DMKRAUV <numeric>	DISPlay[:WINDow]:TRACe:MARKer:RELative {ON 1} DISPlay[:WINDow]:TRACe:MARKer:RELative:REFerence MARKer DISPlay[:WINDow]:TRACe:MARKer:RELative {ON 1} DISPlay[:WINDow]:TRACe:MARKer:RELative:REFerence FIXed DISPlay[:WINDow]:TRACe:MARKer:RELative {ON 1} DISPlay[:WINDow]:TRACe:MARKer:RELative:REFerence TRACked DISPlay[:WINDow]:TRACe:MARKer:RELative {OFF 0} CALCulate:EVALuate:REFerence:DATA? CALCulate:EVALuate:REFerence:X <numeric> CALCulate:EVALuate:REFerence:Y1 <numeric> CALCulate:EVALuate:REFerence:Y2 <numeric>
SA Delta mode menu ΔMKR FIXED ΔMKR TRACKING ΔMKR ΔMODE OFF ΔMKR SWP PRM ΔMKR VALUE RETURN	DMKR ON DMKR FIX DMKR TRAC DMKR OFF DMKRPRM <numeric> DMKRVAL <numeric>	DISPlay[:WINDow]:TRACe:MARKer:RELative {ON 1} DISPlay[:WINDow]:TRACe:MARKer:RELative:REFerence MARKer DISPlay[:WINDow]:TRACe:MARKer:RELative {ON 1} DISPlay[:WINDow]:TRACe:MARKer:RELative:REFerence FIXed DISPlay[:WINDow]:TRACe:MARKer:RELative {ON 1} DISPlay[:WINDow]:TRACe:MARKer:RELative:REFerence TRACked DISPlay[:WINDow]:TRACe:MARKer:RELative {OFF 0} CALCulate:EVALuate:REFerence:X <numeric> CALCulate:EVALuate:REFerence:Y1 <numeric>

Front Panel Key	Simple Command	Equivalent SCPI Command
Sub-marker menu SUB MKR 1 2 3 4 5 6 7	SMKR{1-7} {OFF ON 0 1}	DISPlay[:WINDow]:TRACe:MARKer{2-8}:STATe {OFF ON 0 1}
	SMKRPRM{1-7} <numeric>	CALCulate:EVALuate:Y{2-8}:XPOSITION <numeric>
	OUTPSMKR{1-7}?	CALCulate:EVALuate:Y{2-8}:DATA?
	SMKRPRM{1-7}?	CALCulate:EVALuate:Y{2-8}:XPOSITION?
	SMKRVAL{1-7}?	CALCulate:EVALuate:Y{2-8}:VALue1?
	SMKRAUV{1-7}?	CALCulate:EVALuate:Y{2-8}:VALue2?
RETURN		
Marker--		
MKR--CENTER	MKRCENT	SENSe:FREQuency:CENTer MARKer (Frequency) or SOURce:POWer:CENTer MARKer (Power)
MKR--START	MKRSTAR	SENSe:FREQuency:STARt MARKer (Frequency) or SOURce:POWer:STARt MARKer (Power)
MKR--STOP	MKRSTOP	SENSe:FREQuency:STOP MARKer (Frequency) or SOURce:POWer:STOP MARKer (Power)
MKR--REFERENCE	MKRREF	DISPlay[:WINDow]:TRACe{1 2}:Y[:SCALe]:RLEVel MARKer
PEAK--CENTER	PEAKCENT	SENSe:FREQuency:CENTer TPEak (Frequency) or SOURce:POWer:CENTer TPEak (Power)
CROSS CHAN ON off	CRSC {OFF ON 0 1}	CALCulate:EVALuate:EFFect:ON {1 2}
MORE		
MKR ZOOM	MKRZM	SENSe:FREQuency:SPAN MZAPerture (Frequency) SOURce:POWer:SPAN MZAPerture (Power)
ZOOMING APERTURE	ZMAPER <numeric>	DATA[:DATA] MZAP <numeric>
MKRA--SPAN	MKRDSPAN	SENSe:FREQuency:SPAN DMARKer (Frequency) or SOURce:POWer:SPAN DMARKer (Power)
MKRA--CENTER	MKRDCENT	SENSe:FREQuency:CENTer DMARKer (Frequency) or SOURce:POWer:CENTer DMARKer (Power)
CROSS CHAN ON off	CRSC {OFF ON 0 1}	CALCulate:EVALuate:EFFect:ON {1 2}
RETURN		

Front Panel Key	Simple Command	Equivalent SCPI Command
Peak menu PEAK NEXT PEAK NEXT PEAK LEFT NEXT PEAK RIGHT PEAK DEF MENU → See Peak definition menu SUB MKR → See Sub-marker menu RETURN	SEAM PEAK SEANPK SEANPKL SEANPKR	CALCulate:EVALuate:Y:XPOSITION:PEAK CALCulate:EVALuate:Y:XPOSITION:NPEak CALCulate:EVALuate:Y:XPOSITION:LPEak CALCulate:EVALuate:Y:XPOSITION:RPEak
Multiple peaks menu SEARCH: PEAKS ALL PEAKS RIGHT PEAKS LEFT PEAK DEF MENU → See Peak definition menu SECH TRACK ON off RETURN	SEAM PKSA SEAM PKSR SEAM PKSL TRACK {OFF ON 0 1}	CALCulate:EVALuate:Y:XPOSITION:PALL CALCulate:EVALuate:Y:XPOSITION:PRIGHT CALCulate:EVALuate:Y:XPOSITION:PLEft CALCulate:EVALuate:Y:XPOSITION:TRACk {MAXimum MINimum TARGet PEAK PALL PLEft PRIGHT OFF}
Peak definition menu THRESHOLD ON off THRESHOLD VALUE MKR→THRESHOLD PEAK PLRTY POS neg PEAK DEF: ΔX PEAK DEF: ΔY MKR→PEAKDELTA RETURN	PKTHRE {OFF ON 0 1} PKTHVAL <numeric> MKRTHRE PKPOL {POS NEG} PKDLTX <numeric> PKDLTY <numeric> MKRPKD	CALCulate:EVALuate:PEAK:THREshold:STATe {OFF ON 0 1} CALCulate:EVALuate:PEAK:THREshold <numeric> CALCulate:EVALuate:PEAK:THREshold MARKer CALCulate:EVALuate:PEAK:POLarity {POSitive NEGative} CALCulate:EVALuate:PEAK:EXCURsion:X <numeric> CALCulate:EVALuate:PEAK:EXCURsion[:Y] <numeric> CALCulate:EVALuate:PEAK:EXCURsion DMARker
Width value menu MKRVAL/(√2) MKRVAL*(√2) MKRVAL/2 FIXED VALUE RETURN	WIDVTYPE DIVS2 WIDVTYPE MULS2 WIDVTYPE DIV2 WIDVTYPE FIX WIDV <numeric>	CALCulate:EVALuate:WIDTh:Y DIVS2 CALCulate:EVALuate:WIDTh:Y MULS2 CALCulate:EVALuate:WIDTh:Y DIV2 CALCulate:EVALuate:WIDTh:Y FIXed, <numeric>
Search range menu PART SRCH ON off MKRΔ→SEARCH RNG MKR→LEFT RNG MKR→RIGHT RNG RETURN	PARS {OFF ON 0 1} SEARSTR SEARSTRL SEARSTRR	CALCulate:EVALuate:BAND:FULL[:STATe] {OFF ON 0 1} CALCulate:EVALuate:BAND:SPAN DMARker CALCulate:EVALuate:BAND:STARt MARKer CALCulate:EVALuate:BAND:STOP MARKer

Front Panel Key	Simple Command	Equivalent SCPI Command
Utility Network/Impedance Analyzer MKR LIST ON off STATISTICS ON off MKR TIME ON off SMTH/POLAR MENU — See Circle data menu	MKRL {OFF ON 0 1} MEASTAT {OFF ON 0 1} OUTPMSTA? MKRTIME {OFF ON 0 1}	DISPLAY[:WINDow]:TEXT16:STATe {OFF ON 0 1} CALCulate:EVALuate:MSStatistics[:STATe] {OFF ON 0 1} CALCulate:EVALuate:MSStatistics:DATA? DISPLAY[:WINDow]:TRACe:MARKer:UNIT:TIME {OFF ON 0 1}
Circle data menu REAL IMAG LIN MAG PHASE LOG MAG PHASE R+ jX G+ jB SWR PHASE RETURN	CIRF RI CIRF LIN CIRF LOG CIRF RX CIRF GB CIRF SWR	CALCulate:EVALuate:R:FORMat RIMaginary CALCulate:EVALuate:R:FORMat MLIPhase CALCulate:EVALuate:R:FORMat MLOPhase CALCulate:EVALuate:R:FORMat RX CALCulate:EVALuate:R:FORMat GB CALCulate:EVALuate:R:FORMat SWRPhase
Spectrum Analyzer MKR LIST ON off STATISTICS ON off MKR TIME ON off NOISE FORM ON off	MKRL {OFF ON 0 1} MEASTAT {OFF ON 0 1} OUTPMSTA? MKRTIME {OFF ON 0 1} MKRNOI {OFF ON 0 1}	DISPLAY[:WINDow]:TEXT16:STATe {OFF ON 0 1} CALCulate:EVALuate:MSStatistics[:STATe] {OFF ON 0 1} CALCulate:EVALuate:MSStatistics:DATA? DISPLAY[:WINDow]:TRACe:MARKer:UNIT:TIME {OFF ON 0 1} CALCulate:EVALuate:NOISe[:STATe] {OFF ON 0 1}

Front Panel Key	Simple Command	Equivalent SCPI Command
System		
IBASIC		
Step		PROGRAM[:SElected]:EXECute "STEP"
Continue		PROGRAM[:SElected]:STATe CONTINUE or PROGRAM[:SElected]:EXECute "CONT"
Run		PROGRAM[:SElected]:STATe RUN or PROGRAM[:SElected]:EXECute "RUN"
Pause		PROGRAM[:SElected]:STATe PAUSE or PROGRAM[:SElected]:EXECute "PAUSE"
Stop		PROGRAM[:SElected]:STATe STOP or PROGRAM[:SElected]:EXECute "STOP"
Edit		PROGRAM[:SElected]:EXECute "EDIT"
ASSIGN @Hp4396		
OUTPUT @Hp4396		
ENTER @Hp4396		
END		
GOTO LINE		
RECALL LINE		
END EDIT		
COMMAND ENTRY		
SELECT LETTER		
SPACE		
BACK SPACE		
ERASE TITLE		
DONE		
CANCEL		
ON KEY LABELS		
[USER DEFINE]		
[USER DEFINE]		
[USER DEFINE]		
[USER DEFINE]		
[USER DEFINE]		
[USER DEFINE]		
[USER DEFINE]		
[USER DEFINE]		
[USER DEFINE]		
[USER DEFINE]		
[USER DEFINE]		
[USER DEFINE]		
[USER DEFINE]		
[USER DEFINE]		
[USER DEFINE]		
[USER DEFINE]		
[USER DEFINE]		
[USER DEFINE]		
MEMORY PARTITION		

Front Panel Key	Simple Command	Equivalent SCPI Command
SET CLOCK		
TIME HH:MM:SS		
HOUR		
MIN		
SEC		
ENTER	SETCTIME <h,m,s>	SYSTem:TIME <hour>,<minute>,<second>
CANCEL		
DATE DD/MM/YY		
MONTH		
DAY		
YEAR		
ENTER	SETCDATE <y,m,d>	SYSTem:DATE <year>,<month>,<day>
CANCEL		
DATE MODE:MonDayYear	MONDYEAR	SYSTem:DATE:MODE MDY
DayMonYear	DAYMYEAR	SYSTem:DATE:MODE DMY
RETURN		
BEEPER MENU		
BEEP DONE ON off	BEEPDONE {OFF ON 0 1}	SYSTem:BEEPer1:STATe {OFF ON 0 1}
BEEP WARN ON off	BEEPWARN {OFF ON 0 1}	SYSTem:BEEPer2:STATe {OFF ON 0 1}
RETURN		
LIMIT MENU		
LIMIT LINE ON off	LIMLINE {OFF ON 0 1}	CALCulate:LIMit:LINE {OFF ON 0 1}
LIMIT TEST ON off	LIMITEST {OFF ON 0 1}	CALCulate:LIMit:STATe {OFF ON 0 1}
BEEP FAIL ON off	BEEPFail {OFF ON 0 1}	CALCulate:LIMit:BEEPer[:STATe] {OFF ON 0 1}
EDIT LIMIT LINE	EDITLIML	
SEGMENT	LIMSEDI <numeric>	CALCulate:LIMit:SEGment <numeric>
EDIT	LIMSEDI [<numeric>]	CALCulate:LIMit:SEGment:EDIT
DELETE	LIMSEDEL	CALCulate:LIMit:SEGment:DELEte
ADD	LIMSEADD	CALCulate:LIMit:SEGment:ADD
CLEAR LIST	LIMCLEL	CALCulate:LIMit:CLEar
CLEAR LIST YES		
NO		
DONE	LIMEDONE	CALCulate:LIMit:SAVE
LIMIT LINE OFFSETS		
SWP PARAM OFFSET	LIMIPRMO <numeric>	CALCulate:LIMit:CONTRol:OFFSet <numeric>
AMPLITUDE OFFSET	LIMIAMPO <numeric>	CALCulate:LIMit:OFFSet <numeric>
MKR→AMP.OFS.	MKRAMPO	CALCulate:LIMit:OFFSet MARKer
RETURN		
RETURN		
SERVICE MENU		

Front Panel Key	Simple Command	Equivalent SCPI Command
Limit line entry menu SWP PARAM MKR→SWP PARAM UPPER LIMIT LOWER LIMIT DELTA LIMIT MIDDLE VALUE MKR→MIDDLE DONE	LIMPRM <numeric> MKRSWPRM LIMU <numeric> LIML <numeric> LMD <numeric> LMM <numeric> MKRMIDD LIMSDON	CALCulate:LMit:SEGment:CONTRol[:DATA] <numeric> CALCulate:LMit:SEGment:CONTRol[:DATA] MARKer CALCulate:LMit:SEGment:UPPer <numeric> CALCulate:LMit:SEGment:LOWer <numeric> CALCulate:LMit:SEGment:DELta <numeric> CALCulate:LMit:SEGment:MIDDle <numeric> CALCulate:LMit:SEGment:MIDDle MARKer CALCulate:LMit:SEGment:SAVE
Local SYSTEM CONTROLLER ADDRESSABLE ONLY SET ADDRESSES ADDRESS:4396 ADDRESS:PLOTTER ADDRESS:PRINTER ADDRESS:CONTROLLER RETURN	ADDR PLOT <numeric> ADDR PRIN <numeric> ADDR CONT <numeric>	SYSTem:COMMunicate:GPIB:HCOPY1:ADDRes <numeric> SYSTem:COMMunicate:GPIB:HCOPY2:ADDRes <numeric> SYSTem:COMMunicate:GPIB2:ADDRes <numeric>

Front Panel Key	Simple Command	Equivalent SCPI Command
<p>Copy</p> <p>PRINT [STANDARD]</p> <p>PLOT</p> <p>COPY ABORT</p> <p>COPY TIME ON off</p> <p>PRINT/PLOT SETUP → See Print plot setup menu</p> <p>SELECT QUADRANT → See Select quadrant menu</p> <p>DEFINE PLOT → See Define plot menu</p> <p>MORE → See Copy more menu</p>	<p>PRINALL</p> <p>PLOT</p> <p>COPA</p> <p>COPT {OFF ON 0 1}</p>	<p>HCOPY:DRIVER:LANGUage PCL HCOPY[:IMMediate]</p> <p>HCOPY:DRIVER:LANGUage HPGL HCOPY[:IMMediate]</p> <p>HCOPY:ABORT</p> <p>HCOPY:ITEM:TDSlamp:STATe {OFF ON 0 1}</p>
<p>Copy more menu</p> <p>Network Analyzer</p> <p>LIST VALUES</p> <p>OPERATING PARAMETERS</p> <p>CAL KIT DEFINITION → See Copy cal kit menu</p> <p>LIST SWEEP TABLE → See Copy list sweep menu</p> <p>LIMIT TEST TABLE → See Copy limit test menu</p> <p>RETURN</p> <p>Spectrum Analyzer</p> <p>LIST VALUES</p> <p>OPERATING PARAMETERS</p> <p>LIST SWEEP TABLE → See Copy list sweep menu</p> <p>LIMIT TEST TABLE → See Copy limit test menu</p> <p>RETURN</p> <p>Impedance Analyzer</p> <p>LIST VALUES</p> <p>OPERATING PARAMETERS</p> <p>CAL KIT DEFINITION → See Copy cal kit menu</p> <p>COMPEN KIT DEFINITION</p> <p>LIST SWEEP TABLE → See Copy list sweep menu</p> <p>LIMIT TEST TABLE → See Copy limit test menu</p> <p>RETURN</p>	<p>LISV</p> <p>OPEP</p> <p>LISV</p> <p>OPEP</p> <p>LISV</p> <p>OPEP</p> <p>COMS</p>	<p>DISPlay[:WINDow]:TEXT1:PAGE 1 DISPlay[:WINDow]:TEXT1:STATe {ON 1}</p> <p>DISPlay[:WINDow]:TEXT2:PAGE 1 DISPlay[:WINDow]:TEXT2:STATe {ON 1}</p> <p>DISPlay[:WINDow]:TEXT1:PAGE 1 DISPlay[:WINDow]:TEXT1:STATe {ON 1}</p> <p>DISPlay[:WINDow]:TEXT2:PAGE 1 DISPlay[:WINDow]:TEXT2:STATe {ON 1}</p> <p>DISPlay[:WINDow]:TEXT1:PAGE 1 DISPlay[:WINDow]:TEXT1:STATe {ON 1}</p> <p>DISPlay[:WINDow]:TEXT2:PAGE 1 DISPlay[:WINDow]:TEXT2:STATe {ON 1}</p> <p>DISPlay[:WINDow]:TEXT20:PAGE 1 DISPlay[:WINDow]:TEXT20:STATe ON</p>

Front Panel Key	Simple Command	Equivalent SCPI Command
Copy cal kit menu STANDARD DEFINITION → See Copy standard number menu CLASS ASSIGNMENT RETURN	CALCASSI	DISPlay[:WINDow]:TEXT3:PAGE 1 DISPlay[:WINDow]:TEXT3:STATe {ON 1}
Copy limit test menu DISPLAY LIST DISP MODE: UPR & LWR MID & DLT RETURN	DISLLIST DISMAMP UL DISMAMP MD DISMAMP?	DISPlay[:WINDow]:TEXT{14 15}:PAGE 1 DISPlay[:WINDow]:TEXT{14 15}:STATe {ON 1}
Copy list sweep menu DISPLAY LIST DISP MODE: ST & SP CTR & SPAN RETURN	DISL DISMPRM STSP DISMPRM CTSP DISMPRM?	DISPlay[:WINDow]:TEXT{12 13}:PAGE 1 DISPlay[:WINDow]:TEXT{12 13}:STATe {ON 1}
Copy standard number menu → See Screen menu STD NO.1 STD NO.2 STD NO.3 STD NO.4 STD NO.5 STD NO.6 STD NO.7 STD NO.8	CALS 1 CALS 2 CALS 3 CALS 4 CALS 5 CALS 6 CALS 7 CALS 8	DISPlay[:WINDow]:TEXT4:PAGE 1 DISPlay[:WINDow]:TEXT4:STATe {ON 1} DISPlay[:WINDow]:TEXT5:PAGE 1 DISPlay[:WINDow]:TEXT5:STATe {ON 1} DISPlay[:WINDow]:TEXT6:PAGE 1 DISPlay[:WINDow]:TEXT6:STATe {ON 1} DISPlay[:WINDow]:TEXT7:PAGE 1 DISPlay[:WINDow]:TEXT7:STATe {ON 1} DISPlay[:WINDow]:TEXT8:PAGE 1 DISPlay[:WINDow]:TEXT8:STATe {ON 1} DISPlay[:WINDow]:TEXT9:PAGE 1 DISPlay[:WINDow]:TEXT9:STATe {ON 1} DISPlay[:WINDow]:TEXT10:PAGE 1 DISPlay[:WINDow]:TEXT10:STATe {ON 1} DISPlay[:WINDow]:TEXT11:PAGE 1 DISPlay[:WINDow]:TEXT11:STATe {ON 1}
Define plot menu PLOT: ALL DATA & GRATICULE DATA ONLY LINE TYPE: DATA LINE TYPE: MEMORY SCALE PLOT [FULL] → See Scale plot menu PLOT SPEED [FAST] RETURN	PLOC ALL PLOC DGRAT PLOC DONLY LINTDATA <numeric> LINTMEMO <numeric> PLOS SLOW FAST	HCOPY:ITEM:ANNOtation:STATe {ON 1} HCOPY:ITEM:GRATICule:STATe {ON 1} HCOPY:ITEM:ANNOtation:STATe {OFF 0} HCOPY:ITEM:GRATICule:STATe {ON 1} HCOPY:ITEM:ANNOtation:STATe {OFF 0} HCOPY:ITEM:GRATICule:STATe {OFF 0} HCOPY:ITEM:TRACe1:LTYPe STYLe{0-7} HCOPY:ITEM:TRACe2:LTYPe STYLe{0-7} HCOPY:DRIVer:SPEEd {1 2}

Front Panel Key	Simple Command	Equivalent SCPI Command
Print plot setup menu PRINT STANDARD COLOR PRINT COLOR [FIXED] DEFAULT SETUP RETURN	PRIS PRIC PRICFIXE PRICVARI DFLT	HCOpy:DRIVER:COLor {OFF 0} HCOpy:DRIVER:COLor {ON 1} HCOpy:DRIVER:CMAP:COLor FIXed HCOpy:DRIVER:CMAP:COLor VARiable HCOpy:DEFault
Scale plot menu SCALE:FULL UPPER GRATICULE LOWER GRATICULE RETURN	SCAP FULL SCAP UGRT SCAP LGRT	HCOpy:PAGE:SCALE {1 FULL} HCOpy:PAGE:SCALE UPPER HCOpy:PAGE:SCALE LOWER
Screen menu PRINT [STANDARD] PLOT COPY ABORT COPY TIME ON off PRINT/PLOT SETUP → See Print plot setup menu NEXT PAGE PREV PAGE RESTORE DISPLAY	PRINALL PLOT COPA COPT {OFF ON 0 1} NEXP PREP RESD	HCOpy:DRIVER:LANGUage PCL HCOpy[:IMMEDIATE] HCOpy:DRIVER:LANGUage HPGL HCOpy[:IMMEDIATE] HCOpy:ABORT HCOpy:ITEM:TDSamp:STATe {OFF ON 0 1} DISPlay[:WINDow]:TEXT{1-17}:PAGE UP DISPlay[:WINDow]:TEXT{1-17}:PAGE DOWN DISPlay[:WINDow]:TEXT{1-17}:STATe {OFF 0}
Select quadrant menu x- LEFT - UPPER - LEFT x- LOWER -x RIGHT - UPPER - RIGHT -x LOWER xx FULL xx PAGE RETURN	QUAD LEFU QUAD LEFL QUAD RIGU QUAD RIGL QUAD FULP	HCOpy:PAGE:DIMensions:QUADrant2 HCOpy:PAGE:DIMensions:QUADrant3 HCOpy:PAGE:DIMensions:QUADrant1 HCOpy:PAGE:DIMensions:QUADrant4 HCOpy:PAGE:DIMensions:FULL

Front Panel Key	Simple Command	Equivalent SCPI Command
Save		
STATE	SAVDSTA <string>	MMEMory:STORe:STATe <file_name>[,<msus>]
DATA ONLY (binary)	SAVDDAT <string>	MMEMory:STORe:TRACe SEL,<file_name>[,<msus>]
DEFINE SAVE DATA → See Define save data menu		
ASCII SAVE		
GRAPHICS	SAVDGRA <string>	MMEMory:STORe:DINTerchange:GRAPhics <file_name>[,<msus>]
DATA ONLY (ascii)	SAVDASC <string>	MMEMory:STORe:DINTerchange:TRACe SEL,<file_name>[,<msus>]
DEFINE SAVE DATA → See Define save data menu		
DEFINE EXTENSION → See Define extention menu		
RETURN		
RE-SAVE FILE	RESAVD <string>	MMEMory:DELete <file_name>[,<msus>] MMEMory:STORe:{STATe TRACe} [SEL,]<file_name>[,<msus>]
file name		
file name		
file name		
file name		
PREV FILES		
NEXT FILES		
RETURN		
FILE UTILITIES		
PURGE FILE	PURG <string>	MMEMory:DELete <file_name>[,<msus>]
file name		
file name		
file name		
file name		
PREV FILES		
NEXT FILES		
RETURN		
CREATE DIRECTORY	CRED <string>	MMEMory:CREate:DIRectory <string>
CHANGE DIRECTORY	CHAD <string>	MMEMory:CDIRectory [<string>]
COPY FILE	FILC <string>,<string>, <string>,<string>	MMEMory:COpy <string(s)>,<msus>,<string(d)>,<msus>
file name		
file name		
file name		
file name		
PREV FILES		
NEXT FILES		
RETURN		

Front Panel Key	Simple Command	Equivalent SCPI Command
INITIALIZE DISK INITIALIZE: YES NO FORMAT [LIF] STOR DEV [] RETURN STOR DEV []	INID DISF LIF DISF DOS STOD{DISK MEMO} STOD{DISK MEMO}	MMEemory:INITIALize <msus>,{LIF DOS}
Define extention menu GRAPHICS [.HPG] ASCII DATA [.TXT] RETURN	GRAE <string> ASCE <string>	MMEemory:FNAME:EXTension1 <string> MMEemory:FNAME:EXTension2 <string>
Define save data menu RAW ON off CAL ON off DATA ON off MEM ON off DATA TRACE ON off MEM TRACE ON off RETURN	SAVRAW {ON 1} SAVRAW {OFF 0} SAVCAL {ON 1} SAVCAL {OFF 0} SAVDAT {ON 1} SAVDAT {OFF 0} SAVMEM {ON 1} SAVMEM {OFF 0} SAVDTRC {ON 1} SAVDTRC {OFF 0} SAVMTRC {ON 1} SAVMTRC {OFF 0}	MMEemory:STORe:ITEM:TRACe:SELEct RAW MMEemory:STORe:ITEM:TRACe:DELEte RAW MMEemory:STORe:ITEM:TRACe:SELEct CCO MMEemory:STORe:ITEM:TRACe:DELEte CCO MMEemory:STORe:ITEM:TRACe:SELEct DATA MMEemory:STORe:ITEM:TRACe:DELEte DATA MMEemory:STORe:ITEM:TRACe:SELEct MEM MMEemory:STORe:ITEM:TRACe:DELEte MEM MMEemory:STORe:ITEM:TRACe:SELEct DTR MMEemory:STORe:ITEM:TRACe:DELEte DTR MMEemory:STORe:ITEM:TRACe:SELEct MTR MMEemory:STORe:ITEM:TRACe:DELEte MTR
Purge yes no menu PURGE: YES NO		
Recall file name file name file name file name PREV FILES NEXT FILES STOR DEV []	RECD <string> STOD{DISK MEMO}	MMEemory:LOAD:STATe <file_name>[,<msus>] (State) MMEemory:LOAD:TRACe SEL,<file_name>[,<msus>] (Data)
Preset	PRES	SYSTem:PRESet

Front Panel Key	Simple Command	Equivalent SCPI Command
HP-IB only commands Marker related commands	MKR {ON 1} MKRPRM <numeric> OUTPMKE? MKRVAL? MKRAUV? MKRP <numeric> SMKRP{1-7} <numeric>	DISPlay[:WINDow]:TRACe:MARKer:STATe {ON 1} CALCulate:EVALuate:Y:XPOSITION <numeric> CALCulate:EVALuate:Y:DATA? CALCulate:EVALuate:Y:VALue1? CALCulate:EVALuate:Y:VALue2? CALCulate:EVALuate:Y:XPOSITION:POINT <numeric> CALCulate:EVALuate:Y{2-8}:XPOSITION:POINT <numeric>
8-bit IO related commands	INPSIO? OUTSIO <numeric>	SYSTem:COMMunicate:PARAllel[:RECEive]:DATA? SYSTem:COMMunicate:PARAllel:TRANsmit:DATA <numeric>
Copy related commands	PSOFT {OFF ON 0 1}	HCOpy:ITEM:MENU:STATe {OFF ON 0 1}
KEY related commands	KEY <NUMERIC> ENKEY DSKEY	SYSTem:KEY <numeric> SYSTem:KLOCK {OFF 0} SYSTem:KLOCK {ON 1}
Input/output data array related commands	INPURAW1 INPURAW2 INPURAW3 INPURAW4 INPUDATA INPUDTRC OUTPRAW1? OUTPRAW2? OUTPRAW3? OUTPRAW4? OUTPDATA? OUTPDATAP? <numeric> OUTPMEMO? OUTPMEMOP? <numeric> OUTPDTRC? OUTPDTRCP? <numeric> OUTPMTRC? OUTPMTRCP? <numeric> OUTPSWPRM? OUTPSWPRMP? <numeric>	DATA[:DATA] RAW1,{<block> <numeric> ,<numeric> } DATA[:DATA] RAW2,{<block> <numeric> ,<numeric> } DATA[:DATA] RAW3,{<block> <numeric> ,<numeric> } DATA[:DATA] RAW4,{<block> <numeric> ,<numeric> } DATA[:DATA] DATA,{<block> <numeric> ,<numeric> } TRACe[:DATA] DTR,{<block> <numeric> ,<numeric> } DATA[:DATA]? RAW1 DATA[:DATA]? RAW2 DATA[:DATA]? RAW3 DATA[:DATA]? RAW4 DATA[:DATA]? DATA DATA[:DATA]:VALue? DATA,<point> DATA[:DATA]? MEM DATA[:DATA]:VALue? MEM,<point> TRACe[:DATA]? DTR TRACe[:DATA]:VALue? DTR,<point> TRACe[:DATA]? MTR TRACe[:DATA]:VALue? MTR,<point> DATA[:DATA]? SPAR DATA[:DATA]:VALue? SPAR,<point>

Front Panel Key	Simple Command	Equivalent SCPI Command
Calibration and compensation related commands	INPUCALC{1-12} <numeric> OUTPCALC{1-12}? INPUCALK <numeric> OUTPCALK? SAVC INPUCOMC{1-3} OUTPCOMC{1-3}?	DATA[:DATA] CCO{1-12},{<block> <numeric>[,<numeric>]} DATA[:DATA]? CCO{1-12} DATA[:DATA] CKIT,{<block> <numeric>[,<numeric>]} DATA[:DATA]? CKIT SENSE:CORRection:COLLect:SAVE9 DATA[:DATA] CMP{1-3},{<block> <numeric>[,<numeric>]} DATA[:DATA]? CMP{1-3}
Transfer data format related commands	FORM2 FORM3 FORM4 FORM5	FORMat[:DATA] REAL,32 FORMat[:DATA] REAL,64 FORMat[:DATA] ASCii FORMat[:DATA] PACKed,32
Limit test related commands	OUTPLIMF? OUTPFAIP? OUTPLIMM?	DATA[:DATA]? LFA DATA:POINts? LFA DATA[:DATA]? LMAR
Error related command	OUTPERRO?	SYSTem:ERRor?
Status byte related commands	CLES ESB? ESNB <numeric> OSR? OSE <numeric> OSER? OSPT <numeric> OSNT <numeric>	*CLS (Common Command) STATus:INSTRument[:EVENT]? STATus:INSTRument:ENABle <numeric> STATus:OPERation:CONDition? STATus:OPERation:ENABle <numeric> STATus:OPERation[:EVENT]? STATus:OPERation:PTRansition <numeric> STATus:OPERation:NTRansition <numeric>
Test set related command	TESS?	SYSTem:COMMunicate:TSET?
CRT display related command	SCRn {OFF ON 0 1}	

Front Panel Key	Simple Command	Equivalent SCPI Command
Waveform analysis commands		
Waveform analysis setup commands	ANAOCH1 ANAOCH2 ANARANG ANARFULL ANAODATA ANAOMEMO THRR	
Maximum/Minimum/Mean search commands	OUTPMAX? OUTPMIN? OUTPMINMAX? OUTPMEAN? PEAK? NEXPK? NUMLMAX? NUMLMIN? LMAX? LMIN? TARR? TARL?	
Ripple analysis commands	RPLPP? RPLHEI? RPLRHEI? RPLLHEI? RPLENV? RPLMEA? RPLVAL? POLE?	
Filter and Resonator analysis commands	OUTPFILT? OUTPXFIL? OUTPCFIL? OUTPRESO? OUTPRESR? OUTPRESF? OUTPCERR?	
Equivalent circuit analysis commands	EQUCPARA? EQUM EQUCPARS? EQUCO? EQUCPARS4?	

Front Panel Key	Simple Command	Equivalent SCPI Command
3-term calibration commands	INPUOPEA INPUSHOA INPULOAA INPUD	
Common commands	*CLS *IDN? *OPT? *RST *TST? *OPC *WAI *CLS *ESE <numeric> *ESR? *SRE <numeric> *STB? *TRG *PCB <numeric>	

SCPI Commands Summary

This appendix summarizes the SCPI commands in alphabetical order. It also shows the equivalent simple command when applicable.

Command	Parameter	Note	Equivalent Simple Command
ABORT			HOLD
CALCulate			
:AVERage			
:STATe	{OFF ON 0 1}		DHOLD
:TYPE	{MAXimum MINimum}		DHOLD
:EVALuate			
:BAND			
:FULL			
[:STATe]	{OFF ON}		PARS
:SPAN	DMARker	[no query]	SEARSTR
:START	MARKer	[no query]	SEARSTRL
:STOP	MARKer	[no query]	SEARSTRR
:COUPle	{OFF ON 0 1}		MKRCOUP
:EFFect			
:ON	{1 2}		CRSC
:EPARameters		CALECPARA	
:CIRCuit {A B C D E}		EQUC	
:SMulation		SIMFCHAR	
:INTerpolate	{OFF ON 0 1}		MKRCONT
:MSStatistcs			
:DATA?		[query only]	OUTPMSTA?
[:STATe]	{OFF ON 0 1}		MEASTAT
:NOISe			
[:STATe]	{OFF ON 0 1}		MKRNOI
:ON	{"DTR" "MTR"}		MKRO
:PEAK			
:EXCURsion			
:X	{<numeric> DMARker}		MKRPKD, PKDLTX
[:Y]	{<numeric> DMARker}		MKRPKD, PKDLTY
:POLarity	{POSitive NEGative}		PKPOL
:THReshold	{<numeric> MARKer}		MKRTHRE, PKTHVAL
:STATe	{OFF ON 0 1}		PKTHRE

Command	Parameter	Note	Equivalent Simple Command
CALCulate (continued)			
:EVALuate (continued)			
:REFerence			
:DATA?		[query only]	OUTPDMKR?
:X	<numeric>		DMKRPRM
:Y1	<numeric>		DMKRVAL
:Y2	<numeric>		DMKRAUV
:WIDTh			
:DATA?		[query only]	OUTPMWID?
:STATe	{OFF ON 0 1}		WIDT
:XPOStion			
:IN		[no query]	WIDSEN
:OUT		[no query]	WIDSOUT
:Y	<numeric>		WIDV
:TYPE	{DIVS2 MULS2 DIV2 FIXed}		WIDVTYPE
:Y{1}			
:DATA?		[query only]	OUTPMKR?
:VALue1?		[query only]	MKRVAL?
:VALue2?		[query only]	MKRAUV?
:XPOStion	<numeric>		MKRPRM
:LPEak		[no query]	SEANPKL
:LTARget		[no query]	SEAL
:MAXimum		[no query]	SEAM
:MINimum		[no query]	SEAM
:NPEak		[no query]	SEANPK
:PALL		[no query]	SEAM
:PEAK		[no query]	SEAM
:PLEFt		[no query]	SEAM
:POINt	<numeric>		MKRP
:PRIGHt		[no query]	SEAM
:RPEak		[no query]	SEANPKR
:RTARget		[no query]	SEAR
:TARGet	<numeric>		SEAM, SEATARG
:TRACk	{MAXimum MINimum TARGet PEAK PALL PLEFt PRIGHt OFF}		TRACK
:Y{2-8}			
:DATA?		[query only]	OUTPSMKR{1-7}?
:VALue1?		[query only]	SMKRVAL{1-7}?
:VALue2?		[query only]	SMKRAUV{1-7}?
:XPOStion	<numeric>		SMKRPRM{1-7}
:POINt	<numeric>		SMKRP{1-7}

Command	Parameter	Note	Equivalent Simple Command
CALCulate (continued)			
:FORMat	{GDElay REAL IMAGinary MLNear MLOGarithmic PHASe UPHase SWR COMPLex}		FMT, SAUNIT
:FORMat	{RIMaginary MLIPhase MLOPhase RX GB SWRPhase MLNear PHASe UPHase REAL IMAGinary CP SC LP LS D Q RP RS COMPLex}		FMT, SAUNIT, CIRF, MEAS
:UNIT			
:ANGLE	{DEG RAD}		PHAU
:GDAPerture			
:APERture	<numeric>		GRODAPER
:LIMit			
:BEEPer			
[:STATe]	{OFF ON 0 1}		BEEPFAIL
:CLEar		[no query]	LIMCLEL
:CONTRol			
:OFFSet	<numeric>		LIMIPRMO, MKRAMPO
:LINE	{OFF ON 0 1}		LIMLINE
:OFFSet	{<numeric> MARKer}		LIMIAMPO
:SAVE		[no query]	LIMEDONE
:SEGment	<numeric>		LIMSEDI
:ADD		[no query]	LIMSADD
:CONTRol			
[:DATA]	{<numeric> MARKer}		LIMPRM, MKRSWPRM
:DELeTe		[no query]	LIMSDEL
:DELTA	<numeric>		LIMD
:EDIT		[no query]	LIMSEDI
:LOWer	<numeric>		LIML
:MIDDLE	{<numeric> MARKer}		LIMM, MKRMIDD
:SAVE		[no query]	LIMSDON
:UPPer	<numeric>		LIMU
:STATe	{OFF ON 0 1}		LIMITEST
:MATH1			
[:EXPReSSion]			
:CATalog?		[query only]	(None)
:NAME	{OFF YREF YTRA ZREF ZTRA INVS MP4 MP8 MP16}		CONV
:NAME	{OFF YREF YTRA ZREF ZTRA INVS MP4 MP8 MP16}	(NA)	CONV
	{OFF IMPedance ADMittance}	(ZA)	MEAS

Command	Parameter	Note	Equivalent Simple Command
:MATH2 [:EXPRession] :CATalog? :NAME :PATH? :AUTO	{ADD SUB DIV OFF} [query only] ONCE	[query only] (None)	(None) MATH LVLCAL
DATA [:DATA]? [:DATA] :VALue? :POINTs?	{LFA LMAR MEM SPAR} {AOFF GAIN MZAP}, <numeric> CMP{1 2 3}, <numeric> EQ{R1 C1 L1 C0}, <numeric> {CCO{1-12} DATA RAW{1-4}}, {<block> <numeric>[, <numeric>]} {CKT}, <block> OFFS, {<numeric> MARKer} {DATA MEM SPAR}, <point> LFA	[query only] [query only] [query only] [query only] [query only]	OUTPLIMF?, OUTPLIMM?, OUTPMEMO?, OUTPSWPRM? DATAOVAL, DATGAIN, DEFGO, ZMAPER INPUCOMC{1 2 3}, OUTPCOMC{1 2 3} DERE{R1 C1 L1 C0} INPUCALK, INPUCALC{1-12}, INPUDATA, INPURAW{1-4} DATOVAL, DEFGO, MKROFS OUTPDATAP?, OUTPMEMOP?, OUTPSWPRMP? OUTPFAIP?
DIAG :EREference :LOCKed? :FREvision? :INIT :RESult? :SERvice :BUS :AZERo :DC :FREQ :STATe :WAIT :CCONstant :FRESponse :IFGain :SOURce :XTAL	{OFF ON 0 1} <numeric> <numeric> {OFF ON 0 1} <numeric>	[query only] [query only] [query only]	(None) (None) (None) (None) (None) (None) (None) (None) (None) (None)

Command	Parameter	Note	Equivalent Simple Command
DIAG (continued)			
:SERvice (continued)			
:IF			
:ADMx			
:MODE	{AUTO ALTErnate DEGO DEG90}		(None)
:BPFilteR			
:MODE	{AUTO BW3M BW1M XTAL}		(None)
:GAIN			
:MODE	{AUTO MANual}		(None)
:W	{AUTO DB0 DB10}		(None)
:X	{AUTO DB0 DB18}		(None)
:Y	{AUTO DB0 DB6 DB12 DB18}		(None)
:Z	{AUTO DB0 DB2 DB4 DB18}		(None)
:LPFilter			
:MODE	{AUTO BW5K BW15K BW50K BW150K THROUGH}		(None)
:RANGe			
:F	{HIGH LOW}		(None)
:MODE	{AUTO MANual}	[no query]	(None)
:R	{HIGH LOW}		(None)
:SHBW			
:MODE	{AUTO NARRow MIDDLE WIDE}		(None)
:TLOCAl			
:MODE	{AUTO AC DC}		(None)
:MODE	ON		(None)
:SOURce			
:ALCLoOp	{OPEN CLOSE}		(None)
:ATTenuator	{AUTO DB0 DB10 DB20 DB30 DB40 DB50 DB60}		(None)
:GAIN			
:DAC			
:MODE	{AUTO MANual}		(None)
:VALue	<numeric>		(None)
:LEVel			
:DAC			
:MODE	{AUTO MANual}		(None)
:VALue	<numeric>		(None)
:MODE	{AUTO MANual}		(None)

Command	Parameter	Note	Equivalent Simple Command
DIAG (continued)			
:SERvice (continued)			
:SYNThesizer			
:FLOCAl			
:MODE	{AUTO SINGLE TRIPle}		(None)
:FN			
:MODE	{AUTO NARRow WIDE}		(None)
:STEP			
:DAC			
:MODE	{AUTO MANual}		(None)
:VALue	<numeric>		(None)
:LOOP	{OPEN CLOSE}		(None)
:MODE	{AUTO MANual}		(None)
:OUTPut	{OFF ON 0 1}		(None)
:POLarity	{AUTO POSitive NEGative}		(None)
:TEST	<numeric>	[no query]	(None)
:EXECute		[no query]	(None)
:CONTinue		[no query]	(None)
:REPeat	{OFF ON 0 1}		(None)
:RESult?	<numeric>	[query only]	(None)
:SPEC	{CUSToMer PRODUCTION}	[no query]	(None)
DISPlay			
:ANNOtation			
:FREQuency	OFF		FREO
:BRIGHtness	<numeric>		INTE
:CMAp			
:COLor{1-14}			
:DEFault		[no query]	RSCO
:HSL	<hue>,<sat>,<lum>		COLO
:DEFault			DEFC
:LOAD		[no query]	RECC
:STORE		[no query]	SVCO
:CONTRast	<numeric>		BACI

Command	Parameter	Note	Equivalent Simple Command
DISPlay (continued)			
[:WINDow]			
:ALlocation	{INSTRument HIHB BASic BSTatus}		DISA
:FORMat	{FBACK ULOWer}		SPLD
:TEXT{1-17}			
[:DATA]	<title_string> (only for TEXT17)		TITL
:PAGE	{UP DOWN <numeric>} (except TEXT16 and TEXT17)		CALCASSI, CALS, DISL, DISLLIST, LISV, NEXPL, OPEP, PREP
:STATe	{OFF ON 0 1} (except TEXT17)		CALCASSI, CALS, DISL, DISLLIST, LISV, MKRL, OPEP, RESD
:TEXT18 (18: Equivalent circuit parameters)			
:STATe	{OFF ON 0 1}		DESECPARA
:TEXT19 (19: Equivalent circuit model)			
:STATe	{OFF ON 0 1}		DISECIRC
:TEXT20 (20: Fixture compensation kit definition table)			
:STATe	{OFF ON 0 1}		COMS
:TRACe{[1] 2} (1: Data Trace, 2: Memory Trace)			
:GRATticule			
:FORMat	{RECTangle POLar SMITH ADMittance}	(NA)	FMT
:FORMat	{RECTangle POLar SMITH ADMittance CPLane}	(ZA)	FMT
:MARKer{[1] 2-8} (1: Main Marker, 2-8: Sub Marker)			
:ALL	DEFault	[no query]	PRSMKRS
:STATe	{OFF ON 0 1} (MARKer{2-8} only)		MKR
:RELative	{OFF ON 0 1}		DMKR
:REFerence	{MARKer FLXed TRACKed}		DMKR
:STATe	{OFF ON 0 1} (Only for MARKer{2-8})		SMKR{1-7}
:UNIT			
:TIME	{OFF ON 0 1}		
:X			
[:SCALE]			
:RLEVel	<numeric>		REFX

Command	Parameter	Note	Equivalent Simple Command
:Y [:SCALE]			
:AUTO	ONCE	[no query]	AUTO
:BOTtm	<numeric>		BOTV
:COUPle	{OFF ON 0 1}		SCAC
:PDIVision	<numeric>		SCAL
:RLEVel	{<numeric> MARKer}		REFV, REFY, MKRREF
:RPOStion	<numeric>		REFP
:TOP	<numeric>		TOPV
[:SCALE]			
:SPACing	{LINear LOGarithmic}		FMT
[:SCALE]			
:STATe	{OFF ON 0 1}		
FORMat			
[:DATA]	{ASCIi REAL,32 REAL,64 PACKed,32}		FORM2, FORM3, FORM4, FORM5

Command	Parameter	Note	Equivalent Simple Command
HCOPY			
:ABORt		[no query]	COPA
:DEFault		[no query]	DFLT
:DRIVer			
:CMAP			
:COLor	{FIXed VARIable}		PRICFIXE, PRICVARI
:COLor	{OFF ON 0 1}		PRIC, PRIS
:LANGUage	{HPGL PCL}		PLOT, PRNALL
:SPEed	{1 2}		PLOS
[:IMMediate]		[no query]	PLOT, PRNALL
:ITEM			
:ANNotation			
:STATe	{OFF ON 0 1}		PLOC
:GRATICule			
:STATe	{OFF ON 0 1}		PLOC
:MENU			
:STATe	{OFF ON 0 1}		PSOFT
:TDSamp			
:STATe	{OFF ON 0 1}		COPT
:TRACe{1 2}			
:LTYPe	STYLE{0-7}		LINTDATA, LINTMEMO
:PAGE			
:DIMensions			
:FULL		[no query]	QUAD
:QUADrant{1-4}		[no query]	QUAD
:SCALE	{1 FULL UPPer LOWer}		SCAP
INITiate			
[:IMMediate]		[no query]	NUMG, SING
:AGain			
:ALL		[no query]	REST
:CONTinuous	{OFF ON 0 1}		CONT, HOLD, NUMG, SING
INPut			
:IMPedance	<numeric>		INPZ
INSTrument			
:COUPlE	{OFF ON 0 1}		COUC
:NSElect	{1 2}		CHAN1, CHAN2
[:SElect]	{CH1 CH2}		CHAN1, CHAN2, DUAC
:STATe	{OFF ON 0 1}		CHAN1, CHAN2, DUAC
:TYPE	{NA SA ZA}		NA, SA, ZA

Command	Parameter	Note	Equivalent Simple Command
MMEMemory			
:CDIRectory	[<string>]	[no query]	CHAD
:COPY	<string(src)>,<msus>,<string(des)>,<msus>	[no query]	FILC
:CREate			
:DIRectory	<string>	[no query]	CRED
:DELete	<file_name>[,<msus>]	[no query]	PURG, RESAVD
:FNAMe			
:EXTension{1 2}	<string>		ASCE, GRAE
:INITialize	<msus>,{LIF DOS}	[no query]	INID
:LOAD			
:STATe	<file_name>[,<msus>]		RECD
:TRACe	SEL,<file_name>[,<msus>]		RECD
:STORe			
:DINTerchange			
:GRAPhics	<file_name>[,<msus>]		SAVDGRA
:TRACe	SEL,<file_name>[,<msus>]		SAVDASC
:ITEM			
:TRACe			
:CATalog?		[query only]	SAVCAL?, SAVDAT?, SAVDTR?, SAVMEM?, SAVMTR?, SAVRAW?
:DELete	{CCO DATA DTR MEM MTR RAW}	[no query]	SAVCAL, SAVDAT, SAVDTR, SAVMEM, SAVMTR, SAVRAW
:SELect	{CCO DATA DTR MEM MTR RAW}	[no query]	SAVCAL, SAVDAT, SAVDTR, SAVMEM, SAVMTR, SAVRAW
:STATe	<file_name>[,<msus>]		SAVDSTA
:TRACe	SEL,<file_name>[,<msus>]		SAVDDAT
OUTPut			
:ATTenuation{1 2}	<numeric>		ATTP1, ATTP2

Command	Parameter	Note	Equivalent Simple Command
PROGRAM			
:CATalog?		[query only]	(None)
:EXPLicit			
:DEFine	<programe>,<program>		(None)
:DEFine?	<programe>	[query only]	(None)
:DELete	<programe>	[no query]	(None)
:EXECute	<programe>,<program command>	[no query]	(None)
:MALLocate	<programe>,{<nbytes> DEfault}		(None)
:NAME	<programe>,<program name>		(None)
:NUMBer	<programe>,<varname> {,<nvalues>}		(None)
:STATe	<programe>,{RUN PAUSE STOP CONTinue}		(None)
:STRing	<programe>,<varname> {,<svalues>}		(None)
:WAIT	<programe>		(None)
[:SELEcted]			
:DEFine	<program>		(None)
:DELete			
[:SELEcted]		[no query]	(None)
:ALL		[no query]	(None)
:EXECute	{ "RUN" "PAUSE" "STOP" "STEP" "CONT" }	[no query]	(None)
:MALLocate	{<nbytes> DEfault}		(None)
:NAME	<program name>		(None)
:NUMBer	<varname>{,<nvalues>}		(None)
:STATe	{RUN PAUSE STOP CONTinue}		(None)
:STRing	<varname>{,<svalues>}		(None)
:WAIT			(None)

Command	Parameter	Note	Equivalent Simple Command
SENSe			
:AVERage			
:CLEar		[no query]	AVERREST
:COUNt	<numeric>		AVERFACT
[:STATe]	{OFF ON 0 1}		AVER
:BANDwidth			
[:RESolution]	<numeric>		BW
:AUTO	{OFF ON 0 1}		BW, BWAUTO
:RATio	<numeric>		BWSRAT
:VIDeo	<numeric>		VBW
:TYPE	{LINear LOGarithmic}		VBWT
:CORRection			
:CIMPedance	<numeric>		SETZ
:CKIT	{APC35 APC7 N50 N75 UDEFined}		CALK
:CLASs{1-12}			
:STANdard	<n,n, ... > (max 7 items)	[no query]	SPECS11A, SPECS11B, SPECS11C, SPECS22A, SPECS22B, SPECS22C, SPECFWDm, SPECFWDt, SPECRES1, SPECRESp, SPECREVM, SPECREVT
:LABel	<string>		LABEFWD{T M}, LABERES{P I}, LABEREV{T M}, LABES11{A B C}, LABES22{A B C}
:LABel	<string>		LABK
:MODify		[no query]	MODII
:SAVE	[no query]		SAVEUSEK
:SAVE	{ALL CLASs}	[no query]	CLAD, KITD
:SELect	STANdard{1-8}		DEFS

Command	Parameter	Note	Equivalent Simple Command
SENSe (continued)			
:CORRection (continued)			
:CKIT (continued)			
:CLASs{1-13} (continued)			
:STANdard			
:C0	<numeric>		C0
:C1	<numeric>		C1
:C2	<numeric>		C2
:LABel	<string>		LABS
:OCIMpedance	<numeric>		OFSZ
:ODELay	<numeric>		OFSD
:OLOSs	<numeric>		OFSL
:SAVE		[no query]	STDD
:TIMPedance	<numeric>		TERI
:TYPE	{AIMPedance DELay LOAD OPEN SHORT}		STDT
:COLLect			
:ACQuire	{CS11A CS11B CS11C CS22A CS22B CS22C FWDI FWDI FWDI ISOL ISOL2 OMI REFL REFL2 RESP REVI REVM REVT TRAN TRAN2 STANdard{1-7}}	[no query]	CLASS11{A B C}, CLASS22{A B C}, FWDI, FWDI, FWDI, ISOL, OMI, RAISOL, RAIRESP, REFL, REVI, REVM, REVT, STAN{A-G}, TRAN
:METHod	{NONE RESPonse RAIsol S111 S221 TPORt OPTPort}		CALI
:RESume		[no query]	RESC
:SAVE{1-9}		[no query]	DONE, ISOD, RAID, REFD, RESPDONE, SAV1, SAV2, SAVC, TRAD
:EDELay[1]			
:PORT{1-5}			PORT1, PORT2, PORTA, PORTB, PORTR
[:TIME]	<numeric>		
:STATe	{OFF ON 0 1}		PORE
:EDELay2	{<numeric> MARKer}		ELED, MKRDELA
:OFFSet			
[:MAGNitude]	<numeric>		LVCDT
:PHASe	<numeric>		PHAO
:RVELocity	<numeric>		VELOFACT
[:STATe]	{OFF ON 0 1}		CORR

Command	Parameter	Note	Equivalent Simple Command
:CORRection1		(ZA)	
:CKIT (continued)			
:CLASs{13-15}			
:STANdard	<num1>[,<num2>[, ... [,<num7>]]]		SPECIMP{A B C}
:LABel	<string>		LABIMP{A B C}
:COLLect			
[:ACQuire]	STANdard{1 2 3}	[no query]	CALC
:METhod	{NONE IMP}		CALI
:RESume			RESCOM
:SAVE			SAVIMP
:EDELay			
:PORT6			
[:TIME]	<numeric>		PORTZ
:CORRection2		(ZA)	
:CKIT			
:LABel	<string>		LABECOMK
:MODify			MODICOMK
:SAVE			SAVUCOMK
:SAVE			COMKDONE
:STANdard			
:SAVE			COMSDONE
:STANdard1			
:G	<numeric>		DEFSOPENG
:C	<numeric>		DEFSOPENC
:STANdard2			
:R	<numeric>		DEFSSHORR
:L	<numeric>		DEFSSHORL
:STANdard3			
:R	<numeric>		DEFSLOADR
:L	<numeric>		DEFSLOADL
:COLLect			
:METhod	IMPedance		COMP
[:ACQuire]	STANdard{1 2 3}	[no query]	COMC
:SAVE			SAVCOM
:RESUME			RESCOM

Command	Parameter	Note	Equivalent Simple Command
SENSe (continued)			
:OPEN	{OFF ON 0 1}		COMCDATA
:SHORT	{OFF ON 0 1}		COMCDATB
:LOAD	{OFF ON 0 1}		COMCDATC
:DETECTOR			
:CONTInuous	{OFF ON 0 1}		REPTSMP
[[:FUNCTION]	{NEGative POSitive SAMPLE}		DET
:FREQUENCY			
:CENTer	{<numeric> TPEak DMARKer MARKer}		CENT, MKRCENT, MKRDCENT, PEAKCENT
:STEP			
[:INCRement]	{<numeric> DMARKer MARKer}		CNTS
:AUTO	{OFF ON 0 1}		CNTSAUTO
:MODE	{FIXed LIST SWEep}		SWPT
:SPAN	{<numeric> DMARKer MZAPerture}		MKRSPAN, MKRZM, SPAN
:FULL		[no query]	FULS
:START	{<numeric> MARKer}		MKRSTAR, STAR
:STOP	{<numeric> MARKer}		MKRSTOP, STOP
:FUNCTION	{"POWER 1"} "POWER 2"} "POWER 3"} "POWER 4"} "POWER:S11"} "POWER:S12"} "POWER:S21"} "POWER:S22"} "POWER{1-4}:PSDensity"} "POWER:RATIo 3,2"} "POWER:RATIo 4,2"}		FMT, MEAS
:LIST			
:CLEAr		[no query]	CLEL
:SAVE		[no query]	EDITDONE
:SEGment	<numeric>		(None)
:ADD		[no query]	SADD
:BANDwidth	<numeric>		BW
:DELeTe		[no query]	SDEL
:EDIT		[no query]	SEDI
:FREQUENCY			
:CENTer	<numeric>		CENT
:SPAN	<numeric>		SPAN
:START	{<numeric> MARKer}		MKRSTAR, STAR
:STOP	{<numeric> MARKer}		MKRSTOP, STOP
:POINTs	<numeric>		POIN
:POWER	<numeric>		POWE
:QUIT		[no query]	SQUI
:SAVE		[no query]	SDON

Command	Parameter	Note	Equivalent Simple Command
SENSe (continued)			
:POWer			
:AC			
:ATTenuation	<numeric>		ATT
:AUTO	{OFF ON 0 1}		ATT, ATTAUTO
:RANGe			
[:UPPer]	<numeric>		MAXMLEV
:SWEep			
:COUNT	<numeric>		NUMG, SING
:GATed	{OFF ON 0 1}		TRGS
:DELay	<numeric>		GATDLY
:LENGth	<numeric>		GATLEN
:TRIGger	{EDGE LEVel}		GATCTL
:POINTs	<numeric>		POIN
:SPACing	{LINear LOGarithmic}		SWPT
:TIME	<numeric>		SWET
:AUTO	{OFF ON 0 1}		SWETAUTO
:TRACk			
:SIGNAL			
:MARKer	{OFF ON 0 1}		SGTRK
SOURce			
:FREQuency			
[:CW]	<numeric>		CWFREQ
:POWer			
:CENTer	{<numeric> TPEak DMARKer MARKer}		CENT, MKRCENT, MKRDCENT, PEAKCENT
[:LEVel]			
[:IMMediate]			
[:AMPLitude]	<numeric>		POWE
:SLOPe	<numeric>		SLOPE
:STATe	{OFF ON 0 1}		SLOP
:MODE	{FIXed LIST SWEep}		SWPT
:SPAN	{<numeric> DMARKer MZAPerture}		MKRSPAN, MKRZM, SPAN
:FULL		[no query]	FULS
:STARt	{<numeric> MARKer}		MKRSTAR, STAR
:STATe	{OFF ON 0 1}		RFO
:STOP	{<numeric> MARKer}		MKRSTOP, STOP

Command	Parameter	Note	Equivalent Simple Command
STATUS			
:INSTRument			
:ENABle	<numeric>		ESNB
[:EVENT]?		[query only]	ESB?
:OPERation			
:CONDition?		[query only]	OSR?
:ENABle	<numeric>		OSE
[:EVENT]?		[query only]	OSER?
:NTRANSition	<numeric>		OSNT
:PTRANSition	<numeric>		OSPT
:PRESet			
:QUESTionable			
:CONDition?		[query only]	
:ENABle	<numeric>		
[:EVENT]?		[query only]	

Command	Parameter	Note	Equivalent Simple Command
SYSTEM			
:BEEPer{1 2}			
:STATe	{OFF ON 0 1}		BEEPDONE, BEEPWARN
:COMMunicate			
:GPIB			
:HCOPY{1 2}			
:ADDRes	<numeric>		ADDRPLOT, ADDRPRIN
:GPIB2			
:ADDRes	<numeric>		ADDRCONT
:PARallel			
[:RECeive]			
:DATA?		[query only]	INP8IO?
:TRANsmit			
:DATA	<numeric>	[no query]	OUT8IO
:TSET?		[query only]	TESS?
:DATE	<year>, <month>, <day>		SETCDATE
:MODE	{DMY MDY}		DAYMYEAR, MONDYEAR
:ERRor?		[query only]	OUTPERRO?
:FIXTuer	{NONE HP16191 HP16192 HP16193 HP16194 USER}		FIXT
:DISTance	<numeric>		FIXE
:LABel	<string>		LABEFIX
:MODify			MODIFX
:SAVE			FIXKDONE
:SAVE			SAVUFIXT
:KEY	<numeric>		KEY
:KLOCK	{OFF ON 0 1}		DSKEY, ENKEY
:PRESet		[no query]	PRES
:SECurity			
[:STATe]	ON		FREO
:TIME	<hour>, <minute>, <second>		SETCTIME
:VERSion?		[query only]	(None)
TRACe			
:COPY	{MTRace, DTRace}	[no query]	DATMEM
[:DATA]	{DTR MTR}, {<block> <numeric> , <numeric>}		INPUTDTRC, OUTPUTDTRC?, OUTPMTRC?
:VALue?	{DTR MTR}, <point>	[query only]	OUTPUTDTRCP?, OUTPMTRCP?

Command	Parameter	Note	Equivalent Simple Command
TRIGger :EVENT :TYPE :LEVel :SLOPe :SOURce	 {POINt SWEep} <numeric> {POSitive NEGative} {BUS EXTernal INTernal1 INTernal2 MANual}		TRGEVE VIDLVL TRGP TRGS
UNIT :POWer	{DBM DBUV DBV V W}		SAUNIT

Status Reporting

The Status byte register (STB) summarizes four status registers that indicate the internal condition of the analyzer. Figure D-1 shows the status reporting structure of the analyzer.

D:Status Reporting

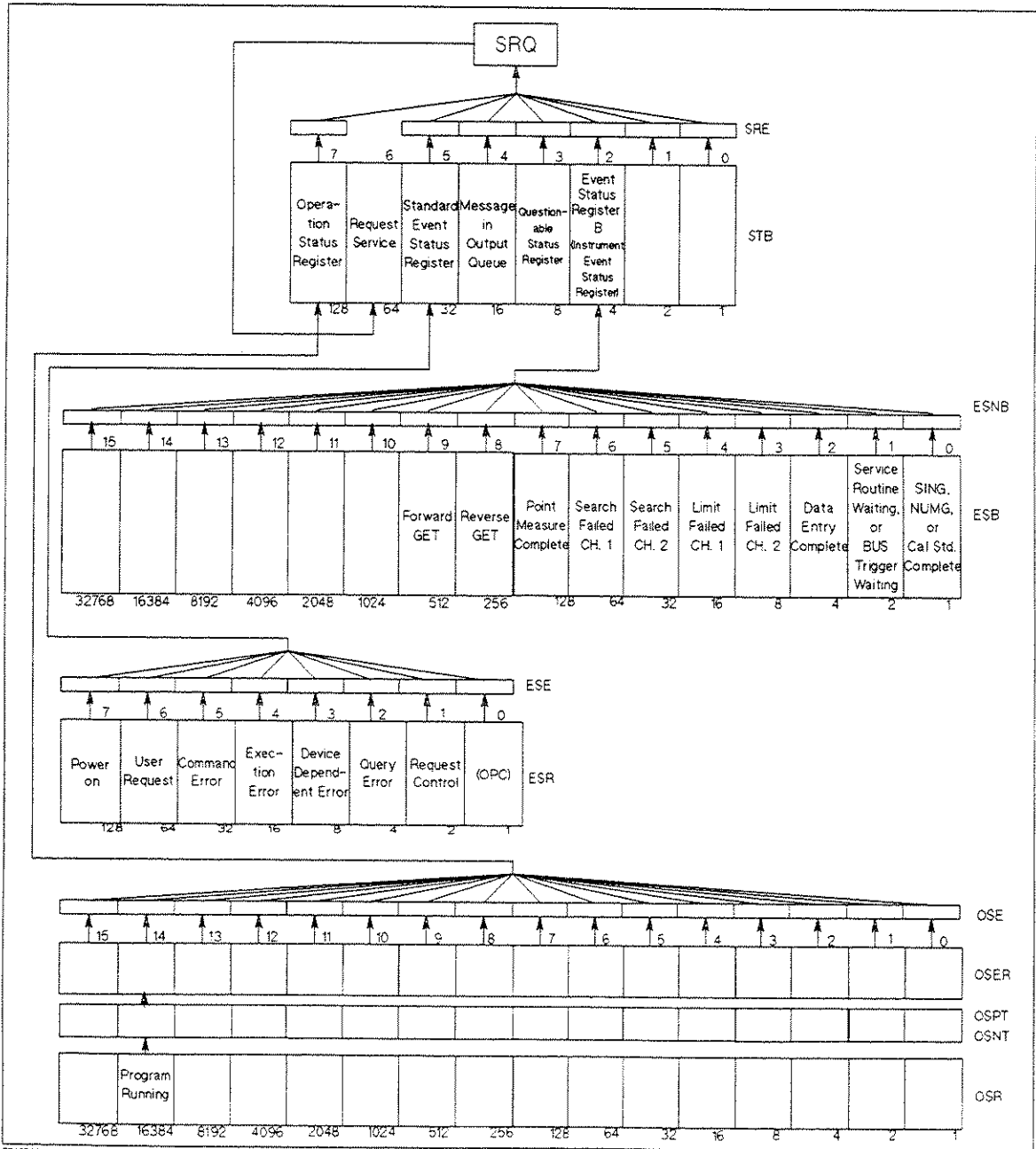

Figure D-1. Status Reporting Structure

The analyzer has a status reporting system to report the condition of the analyzer. The status bytes consist of 8-bit registers, with each bit representing a specific analyzer condition. The value of the Status Byte can be read by using SPOLL(717) statement from an external controller. This command reads a value directly from the analyzer without being set to remote. So, you can operate front panel keys while a controller is reading the Status Byte. Contents of the Status Byte can also be read by using the *STB? command. Reading the Status Byte does not affect the contents of the Status Byte. Table D-1 shows contents of Status Byte.

Table D-1. Status Bit Definitions of the Status Byte (STB)

Bit	Name	Description
2	Event Status Register B Summary Bit	One of the enabled bits in Event Status Register B (Instrument Event Status Register) has been set.
3	Questionable Status Register Summary Bit	The analyzer has no operation to report the event to the Questionable Status Register group. This register is available to keep the consistency with other SCPI compatible instruments.
4	Message in Output Queue	A command has prepared information to be output, but it has not been read yet.
5	Standard Event Status Register Summary Bit	One of the enabled bits in the Standard Event Status Register has been set.
6	Request Service	One of the enabled Status Byte bits is causing an SRQ.
7	Operation Status Register Summary Bit	One of the enabled bits in the Operation Status Register has been set.

For example, to read the contents of Message in the output queue,

```

10 Stat=SPOLL(717)
20 Stb4=BIT(Stat,4)
30 PRINT Stb4
40 END

```

Figure D-2. Example of Reading Status Byte (1)

or,

```

10 ASSIGN @Hp4396 TO 717
20 OUTPUT @Hp4396;"*STB?"
30 ENTER @Hp4396;Stat
40 Stb4=BIT(Stat,4)
50 PRINT Stb4
60 END

```

Figure D-3. Example of Reading Status Byte (2)

The Standard Event Status Register (ESR), Event Status Register B (ESB; Instrument Event Status Register), and Operation Status Register (OSR) are subordinate to the Status Byte. Each

D-2 Status Reporting

register can set a bit with a condition that is watched by status bit. A status bit is cleared when it is read by query or the CLES or *CLS command is executed.

Table D-2.
Status Bit Definitions of the Standard Event Status Register (ESR)

Bit	Name	Description
0	Operation Complete	A command for which OPC has been enabled, and completed an operation.
1	Request Control	The analyzer has been commanded to perform an operation that requires control of a peripheral, and needs control of HP-IB.
2	Query Error	<ol style="list-style-type: none"> 1. The analyzer has been addressed to talk, but there is nothing in the output queue to transmit. 2. Data in the Output Queue has been lost.
3	Device Dependent Error	An error, other than a command error, a query error, and an execution error has occurred.
4	Execution Error	<ol style="list-style-type: none"> 1. A program data element following a header exceeded its input range, or is inconsistent with the analyzer's capabilities. 2. A valid program message could not be properly executed due to some analyzer condition.
5	Command Error	<ol style="list-style-type: none"> 1. An IEEE 488.2 syntax error has occurred. Possible violations include, a data element violated the analyzer listening formats or a data element type is unacceptable to the analyzer. 2. A semantic error that indicates an unrecognized header was received has occurred. Unrecognized headers include incorrect device-specific headers and incorrect or unimplemented IEEE 488.2 common commands. 3. A Group Execute Trigger (GET) was entered into the Input Buffer of a program message.
6	User Request	The operator pressed a front panel key or an optional keyboard key or turned the rotary knob.
7	Power ON	A power-on sequence has occurred since the last read of the register.

Table D-3. Status Bit Definitions of the Event Status Register B (ESB)

Bit	Name	Description
0	SING, NUMG, or Cal Std. Complete	A single, group sweep, calibration, or compensation has been completed since the last read of the register. Operates in conjunction with SING or NUMG.
1	Service Routine Waiting or Bus Trigger Waiting	1. An internal service routine has completed an operation, or is waiting for an operator response. 2. The analyzer has set the manual trigger to the point mode and is waiting for a manual trigger.
2	Data Entry Complete	A terminator key has been pressed.
3	Limit Failed, Ch 2	Limit test failed on channel 2.
4	Limit Failed, Ch 1	Limit test failed on channel 1.
5	Search Failed, Ch 2	A marker search was executed on channel 2, but the target value was not found.
6	Search Failed, Ch 1	A marker search was executed on channel 1, but the target value was not found.
7	Point Measurement Complete ¹	One measurement point of a sweep has been completed.
8	Reverse GET	A one-path 2-port calibration is active, and the analyzer has stopped, waiting for the operator to connect the device for a reverse measurement.
9	Forward GET	A one-path 2-port calibration is active, and the analyzer has stopped, waiting for the operator to connect the device for a forward measurement.

¹ This bit is set only when the related bits of both SRE and ESNB are enabled.

In the case of the manual trigger on point mode, the analyzer accepts the next trigger while the current measurement is in progress (up to the number of points). Use bit 1 and bit 7 correctly to synchronize the measurement and external triggering. For example, 1) wait until bit 1 is set, 2) trigger, and 3) wait until bit 7 is set.

Table D-4. Status Bit Definitions of the Operation Status Register (OSR)

Bit	Name	Description
14	Program running	An HP Instrument BASIC program is running.

Each status register has a register that enables generating a Service Request (SRQ) with a condition of a status bit. For instance, to generate an SRQ when the analyzer completes the specified number of sweeps, enable ESNB bit 1. Bit 1 of ESNB is the mask register for ESB 0 ("SING, NUMG, or Cal Std. Complete") which shows sweep completion and SRE bit 2. This enables a path from ESB bit 0 to generate an SRQ. Figure D-4 shows a program listing that can be used to generate an SRQ.

```

10 ASSIGN @Hp4396 TO 717
20 !
30 OUTPUT @Hp4396;"CLES" ! Clears status registers
40 OUTPUT @Hp4396;"ESNB 1" ! Enables mask register of "SING. NUMG. or
50 ! ! Cal Std. Complete" of ESB
60 OUTPUT @Hp4396;"*SRE 4" ! Enables mask register of "Event Status
70 ! ! Register B" of STB
80 !
90 ON INTR 7 GOTO End ! Declare SRQ interrupt
100 ENABLE INTR 7;2
110 OUTPUT @Hp4396;"SING" ! Execute single sweep
120 GOTO 120 ! Endless loop
130 !
140 End: ! Exit from loop when sweep is completed
150 END

```

Figure D-4. Example of Generating a Service Request (SRQ)

OSPT, OSNT

OSPT (Operation Status Positive Transition Filter)

Sets the positive transition filter. Setting a bit in OSPT will cause a 0 to 1 transition in the corresponding bit of the associated Operation Status Register (OSR) to cause a 1 to be written in the associated bit of corresponding Operation Status Event Register (OSER).

Bit 14 of the analyzer's OSR is used to show program status. When bit 14 of OSPT is set to 1, starting a program causes a 1 to be written in bit 14 of OSER. (This sets bit 7 of STB to 1.)

OSNT (Operation Status Negative Transition Filter)

Sets the negative transition filter. Setting a bit in the negative transition filter will cause a 1 to 0 transition in the corresponding bit of the associated Operation Status Register to cause a 1 to be written in the associated bit of corresponding Operation Status Event Register.

Bit 14 of the analyzer's OSR is used to show program status. When bit 14 of OSNT is set to 1, stopping a program causes a 1 to be written in bit 14 of OSER. (This sets bit 7 of STB to 1.)

Trigger System

Trigger System

This section provides information about the trigger system of the analyzer. SCPI defines a common trigger model for several types of instruments. A trigger system allows you to have control of your measurements.

Information on the trigger system requires more technical expertise than most other topics covered in this chapter. But you can avoid having to learn the information in this chapter by using the :INITiate commands to make your measurements.

Analyzer Trigger System Configuration

The trigger system synchronizes the analyzer measurement with specified events. Events include an HP-IB trigger command or input pulse on the EXT TRIGGER input. The trigger system also allows you to specify the number of times to repeat a measurement and the delays between measurements.

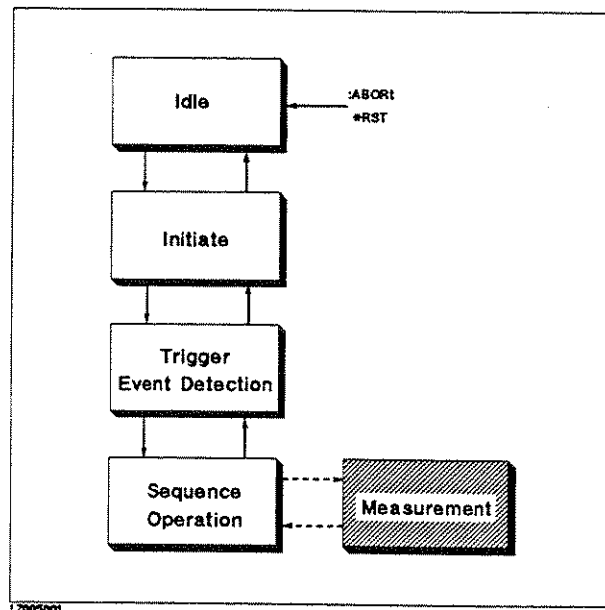

Figure E-1. Trigger System Configuration

Figure E-1 shows the configuration of the analyzer trigger system. Each unshaded block is called a **trigger state**. The analyzer moves between adjacent states depending on its conditions. The power ON state is called the **Idle** state. You can force the analyzer to the idle state using the :ABORT or *RST command. The **Initiate** and **Trigger Event Detection** state branches to next state, whether the analyzer satisfies the specified conditions or not. The **Sequence Operation** state signals the instrument hardware to take a measurement and listens for a signal saying that the measurement has been taken.

Idle State

The trigger system remains in the Idle state until it is initiated by :INITiate:IMMediate or :INITiate:CONTinuous ON. Once one of these conditions is satisfied, the trigger system exits downward to the Initiate state. Note that *RST sets :INITiate:CONTinuous OFF.

Initiate State

If the trigger system is on a downward path, it travels directly through the Initiate state without restrictions. If the trigger system is on an upward path, and :INITiate:CONTinuous is ON, then it exits downward to an Trigger Event Detection state. If the trigger system is on an upward path and :INITiate:CONTinuous is OFF, then it exits upward to the Idle state.

Trigger Event Detection State

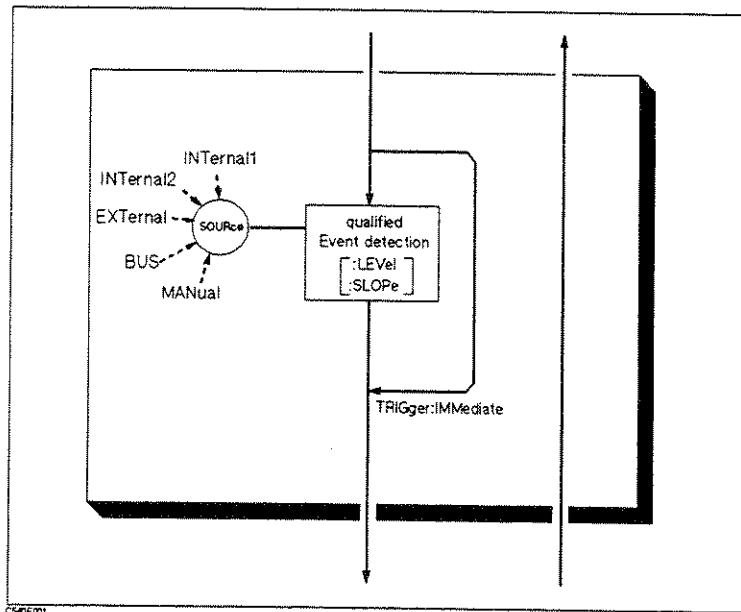

Figure E-2. Inside an Trigger Event Detection State

SOURCE The :TRIGger:SOURce command specifies which particular input can generate the event required to continue the downward path. If the source chosen is a nonanalog signal such as IMMEDIATE or BUS, then no further qualifications are required to generate an event. However when an INTERNAL1, INTERNAL2, or EXTERNAL analog signal is chosen, you can specify additional qualifications by using the appropriate LEVEL and SLOPE commands. Sending *RST sets the SOURCE to IMMEDIATE.

IMMEDIATE The :TRIGger:IMMediate command bypasses the event detection and DELAY qualifications one time. The upward path through the Trigger Event Detection state contains only one condition. If the condition is satisfied, the trigger system exits upward.

Sequence Operation State

The downward entrance to the Sequence Operation state forces the analyzer to start a measurement. An upward exit is not allowed until the measurement is complete.

Calibration Types and Standard Classes, and Calibration Arrays

Table F-1 lists which standard classes are required for each calibration type. Table F-2 specifies where the calibration coefficients are stored for different calibration types.

Table F-1. Calibration Types and Standard Classes

Class	Response	Response and Isolation	S ₁₁ 1-port	S ₂₂ 1-port	One-path 2-port	Full 2-port	ZA calibration
Response:	•						
Response and isolation:							
Response		•					
Isolation		•					
Reflection: ¹							
S11A (opens)			•		•	•	
S11B (shorts)			•		•	•	
S11C (loads)			•		•	•	
S22A (opens)				•		•	
S22B (shorts)				•		•	
S22C (loads)				•		•	
Transmission: ¹							
Forward match					•	•	
Forward thru					•	•	
Reverse match						•	
Reverse thru						•	
Isolation: ¹							
Forward					•	•	
Reverse					•	•	
Impedance analyzer cal							
IMPA (OPEN)							•
IMPB (SHORT)							•
IMPC (LOAD)							•

¹ These subheadings must be called when doing 2-port calibrations.

F: Calibration Types and Standard Classes, and Calibration Arrays

Calibration Arrays

Table F-2. Calibration Array

Array	Response ¹	Response and Isolation ¹	1-port ¹ ZA cal	2-port ^{1,2}
1	E _R or E _T	E _X (E _D) ³ E _T (E _R)	E _D E _S E _R	E _{DF}
2				E _{SF}
3				E _{RF}
4				E _{XF}
5				E _{LF}
6				E _{TF}
7				E _{DR}
8				E _{SR}
9				E _{RR}
10				E _{XR}
11				E _{LR}
12				E _{TR}

1 Meaning of first subscript: D = directivity; S = source match; X = crosstalk; L = load match; T = transmission tracking.

Meaning of second subscript: F = forward; R = reverse.

2 One path, 2-port cal duplicates arrays 1 to 6 in arrays 7 to 12.

3 Response and isolation corrects for crosstalk and transmission tracking in transmission measurements, and for directivity and reflection tracking in reflection measurements.

Key Codes

Figure G-1 shows the codes of the front panel keys for using the KEY HP-IB command.

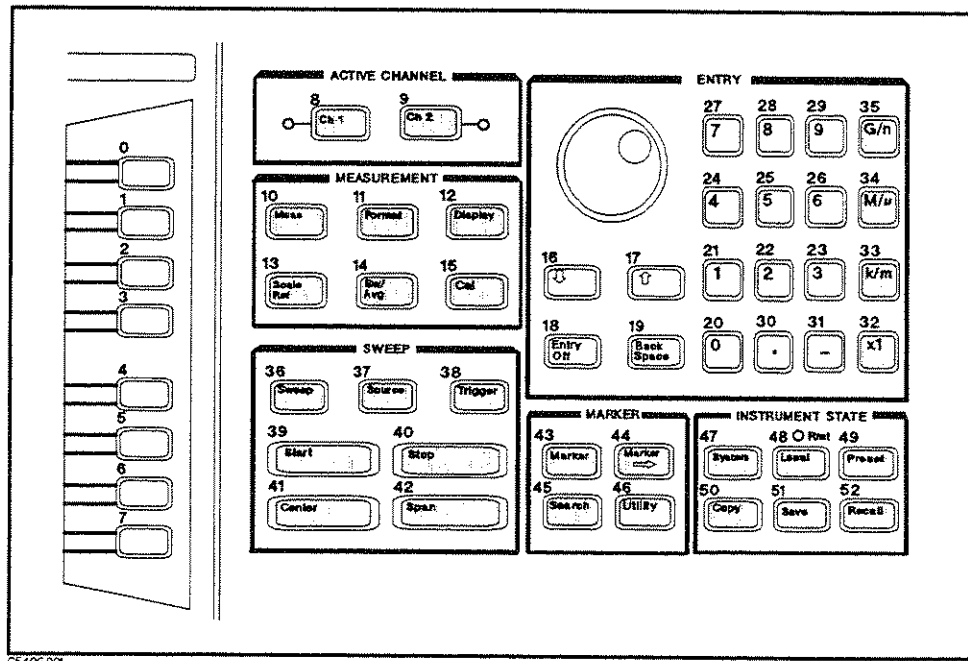

0540G001

Figure G-1. Key Codes

Data Format and Data Levels

Data Format

The analyzer can transmit data over HP-IB in four different formats. The type of format affects what kind of data array is declared (real or integer), because the format determines what type of data is transferred.

■ **Form 2**

IEEE 32-bit floating point format. Figure H-1 shows the data transfer format of Form 2. In this mode, each number takes 4 bytes.

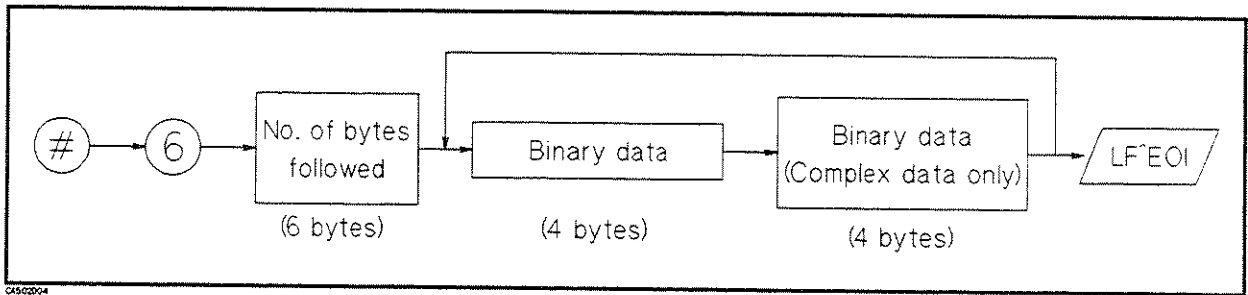

Figure H-1. Form 2 Data Transfer Format

■ **Form 3**

IEEE 64-bit floating point format. Figure H-2 shows the data transfer format of Form 3. Data is stored internally in the 200/300 series computer with the IEEE 64-bit floating point format, eliminating the need for any reformatting by the computer. In this mode, each number takes 8 bytes.

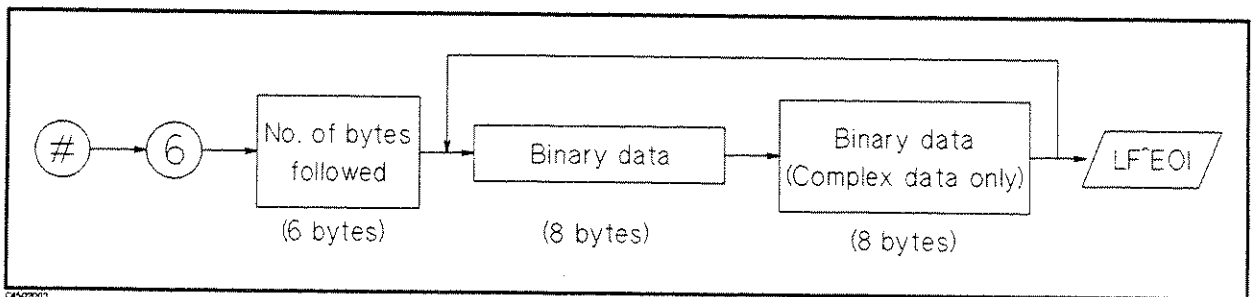

Figure H-2. Form 3 Data Transfer Format

■ **Form 4**

ASCII data transfer format. In this mode, each number is sent as a 24-character string, each character being a digit, sign, or decimal point.

- Form 5

MS-DOS[®] personal computer format. This mode is a modification of IEEE 32-bit floating point format with the byte order reversed. Form 5 also has a four-byte header that must be read in so that data order is maintained. In this mode, an MS-DOS[®] PC can store data internally without reformatting it.

Data Levels

The analyzer has the following data arrays in internal memory:

- Raw data

These arrays store the results of all the preceding data processing operations. Note that the numbers here are still complex pairs.

When the Network analyzer mode and the full 2-port error correction are on, the raw data arrays contain all four S-parameter measurements required for accuracy enhancement.

- Error corrected data

The results of error correction are stored in the data arrays as complex number pairs.

- Formatted data

This is the array of data being displayed. It reflects all post-processing functions such as electrical delay, and the units of the array read out depends on the current display format.

- Calibration coefficients (Network and impedance analyzer only)

The results of a calibration are stored arrays of calibration coefficients that are used by the error correction routines. Each array corresponds to a specific error term in the error model. The calibration coefficients are read out with OUTPCALC{1-12}?.

- fixture compensation coefficients (Impedance analyzer only)

The results of a fixture compensation are stored arrays of fixture compensation coefficients that are used by the error correction routines. Each array corresponds to a specific error term in the error model. The fixture compensation coefficients are read out with OUTPCOMC{1-3}?.

Formatted data is generally the most useful, because it is the same information as that seen on the display. However, if post-processing is not necessary, as may be the case with smoothing, error corrected data is more desirable. Error corrected data also gives you the opportunity to load the data into the instrument and apply post-processing at a later time.

For more information of the data processing, refer to "Data Processing Flow" in chapter 12 of the *Reference Manual*.

Marker Readout

The values specified by the marker, sub-marker, or delta-marker can be read using the following commands.

OUTPMKR?, OUTPSMKR?, OUTPDMKR?	Amplitude value (Value 1), Auxiliary amplitude value (Value 2), Sweep Parameter
MKRVAL?, SMKRVAL{1-7}?	Amplitude value (Value 1)
MKRAUV?, SMKRAUV{1-7}?	Auxiliary amplitude value (Value 2)

The following table lists the amplitude value (value 1) and the auxiliary amplitude value (value 2) for each display format.

Table H-1. Marker Readout

Analyzer Type	Display Format	Parameter of CIRF Command	Amplitude Value (Value 1)	Auxiliary Amplitude Value (Value 2)
Network Analyzer	Log Magnitude	—	Log Magnitude (dB)	0
	Phase	—	Phase (degrees)	0
	Expanded Phase	—	Phase (degrees)	0
	Delay	—	Delay (seconds)	0
	Linear Magnitude	—	Linear Magnitude	0
	SWR	—	SWR	0
	Real	—	Real	0
	Imaginary	—	Imaginary	0
Network/impedance Analyzer ¹	Smith Chart	RI	Real	Imaginary
	Polar	LIN	Linear Magnitude	Phase (degrees)
	Addmittance	LOG	Log Magnitude (dB)	Phase (°)
		RX	Resistance (Ω)	Reactance (Ω)
		GB	Conductance (S)	Suseptance (S)
		SWR	SWR	Phase (°)
Spectrum Analyzer	Spectrum Measurement	—	Magnitude (dBm, dBV, dB μ V, W, or V) ²	0
	Noise Level Measurement	—	Magnitude (dBm, dBV, dB μ V, W, or V) ²	0

¹ For the other format than listed above in the impedance analyzer mode, the marker readout has the unit of the selected parameter by **Meas** key.

² Unit is specified by the SAUNIT command. (default: dBm)

Waveform Analysis Commands

The HP 4396A has added a command set that can be used to analyze waveforms of specific devices. The waveform analysis commands analyze and output the results using only a single command. This appendix provides information about the added waveform analysis commands.

The commands are divided into five groups as follows:

- Waveform analysis setup commands
- Maximum/Minimum/Mean search commands
- Ripple analysis commands
- Filter and Resonator analysis commands
- Equivalent circuit analysis commands

All of the commands that are described in this appendix are executable using the Instrument BASIC EXECUTE command. By using the EXECUTE command, you can execute the waveform analysis commands much faster than by using the OUTPUT statement. If you use Instrument BASIC, it is recommended that you use EXECUTE with the waveform analysis commands.

For detail information about EXECUTE command, see the *Using HP Instrument BASIC with HP 4396A* manual.

Conventions and Definitions

This section describes the conventions and definitions that are used to describe the waveform analysis commands.

- ① → **ANARANG**
- ② → Sets the stimulus range for the waveform. . . .
- ③ → **Syntax** **ANARANG** *start,stop*
- ④ → Where,
 0 *start* Start value of the analysis range
 1 *stop* Stop value of the analysis range
- ⑤ → **Query**
 Response
- ⑥ → **Semantics**
- ⑦ → **Note**
- ⑧ → **Examples**

①	Command name.
②	Command description.
③	<p>Command syntax</p> <p>This part shows the syntax of the command. You must put a space between the command and the parameters.</p>
④	<p>Command parameter description</p> <p>The first column of the table lists the register number that is used by the EXECUTE command. You must put the parameter in the indicated register before using the EXECUTE command. For example (in the above case):</p> <pre style="margin-left: 40px;">WRITEIO 15,0;Start Put "Start" in register 0. WRITEIO 15,1;Stop Put "Stop" in register 1. EXECUTE "ANARANG" Execute "ANARANG".</pre> <p>The second column lists the parameter name that is shown in the Syntax area. The third column describes the parameters.</p>
⑤	<p>Query response.</p> <p>This part shows what values will be returned as the query response. The description of the query response is similar to the description of the Syntax area shown above.</p>
⑥	<p>Semantics</p> <p>This part describes how the command obtains the values for the query response.</p>
⑦	<p>Note</p> <p>This part describes the required conditions or limitations when using the command.</p>
⑧	<p>Examples</p> <p>This part shows examples of how to use the command. Examples are provided for both HP BASIC on an external controller and Instrument BASIC on the analyzer.</p>

Waveform Analysis Setup Commands

The following commands are used for setting up the conditions for waveform analysis:

- ANAOCH1
- ANAOCH2
- ANARANG
- ANARFULL
- ANAODATA
- ANAOMEMO
- THRR

The settings are effective for all of the waveform analysis commands.

ANAOCH1

Selects channel 1 for waveform analysis.

Syntax ANAOCH1

Query *boolean*

Response Where,

Register	Parameter	Description
0	<i>boolean</i>	1 or 0. Channel 1 is selected (1) or is not selected (0) for waveform analysis.

Note ■ The ANAOCH1 and ANAOCH2 channel setting is independent of the active channel setting.

ANAOCH2

Selects channel 2 for waveform analysis.

Syntax ANAOCH2

Query *boolean*

Response Where,

Register	Parameter	Description
0	<i>boolean</i>	1 or 0. Channel 2 is selected (1) or is not selected (0) for waveform analysis.

Note ■ The ANAOCH1 and ANAOCH2 channel setting is independent of the active channel setting.

ANARANG

Sets the stimulus range for waveform analysis commands by start and stop value.

Syntax ANARANG *start, stop*

Where,

Register	Parameter	Description
0	<i>start</i>	Start value of the analysis range.
1	<i>stop</i>	Stop value of the analysis range.

Query *start, stop*

Response

Note

- The waveform analysis range is independent of the marker search range.
- You can set the range for each channel independently. Therefore, you need to set the analysis channel using ANAOCH1 or ANAOCH2 before using ANARANG.
- The waveform analysis range will be truncated to fit the displayed stimulus range if the setting is exceeded.
- If the displayed stimulus range is changed, the waveform analysis range is set equal to the displayed range.
- Store the waveform analysis range setting using **SAVE ALL** or **STATE ONLY**.
- The waveform analysis range is set to equal to the displayed stimulus range when the power is turned on.

Examples For External Controller

```
INPUT "Enter Start for Analysis Range.",Start
INPUT "Enter Stop for Analysis Range.",Stop
OUTPUT @Hp4396;"ANARANG ";Start,Stop
```

For Instrument BASIC

```
INPUT "Enter Start for Analysis Range.",Start
INPUT "Enter Stop for Analysis Range.",Stop
WRITEIO 8,0;Start
WRITEIO 8,1;Stop
EXECUTE "ANARANG"
```

ANARFULL

Sets the waveform analysis range equal to the displayed stimulus range. (No Query)

Syntax ANARFULL

Note

- You can set the range for each channel independently. Therefore, you need to set the analysis channel using ANAOCH1 or ANAOCH2 before using ANARFULL.

ANAODATA

Selects the data trace for waveform analysis.

Syntax ANAODATA

Query *boolean*

Response Where,

Register	Parameter	Description
0	<i>boolean</i>	1 or 0. Data trace is selected (1) or is not selected (0) for waveform analysis.

- Note**
- You can select the trace for each channel independently. Therefore, you need to set the analysis channel using ANAOCH1 or ANAOCH2 before using ANAODATA.

ANAOMEMO

Selects the data trace for waveform analysis.

Syntax ANAOMEMO

Query *boolean*

Response Where,

Register	Parameter	Description
0	<i>boolean</i>	1 or 0. Memory trace is selected (1) or is not selected (0) for waveform analysis.

- Note**
- You can select the trace for each channel independently. Therefore, you need to set the analysis channel using ANAOCH1 or ANAOCH2 before using ANAOMEMO.

THRR

Sets threshold ripple height for waveform analysis commands.

Syntax THRR *height*

Where,

Register	Parameter	Description
0	<i>height</i>	(Peak height) - (negative peak height)

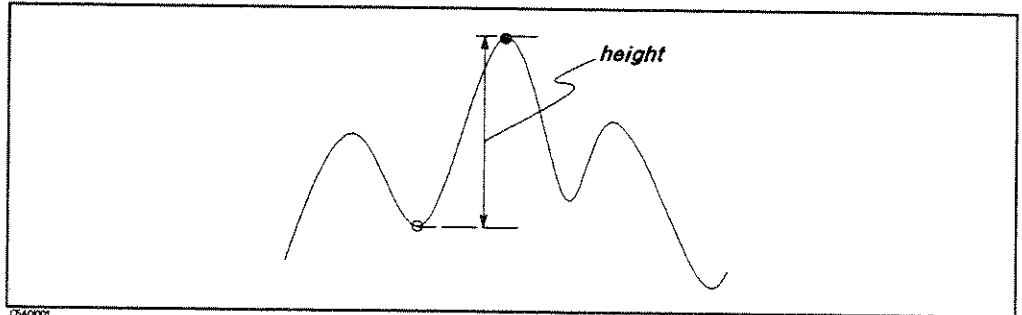

Figure I-1. THRR

Query *height*

Response

- Semantics**
- Ripple height is defined as the difference between the positive peak and the negative peak.
 - Waveform analysis commands search only for ripples greater than the threshold value, any others are ignored.

Note ■ Default threshold value is 0.

Examples For External Controller

```
INPUT "Enter Pos. Peak Gain [dB].",Local_max
INPUT "Enter Neg. Peak Gain [dB].",Local_min
Height=Local_max-Local_min
OUTPUT @Hp4396;"THRR ";Height
```

For Instrument BASIC

```
INPUT "Enter Pos. Peak Gain [dB].",Local_max
INPUT "Enter Neg. Peak Gain [dB].",Local_min
Height=Local_max-Local_min
WRITEIO 8,0;Height
EXECUTE "THRR"
```

Maximum/Minimum/Mean Value Search Commands

The following commands return the maximum, minimum, and mean value of a trace within the range specified using the ANARANG command.

- OUTPMAX?
- OUTPMIN?
- OUTPMINMAX?
- OUTPMEAN?
- PEAK?
- NEXPK?
- NUMLMAX?
- NUMLMIN?
- LMAX?
- LMIN?
- TARR?
- TARL?

OUTPMAX?

Returns the maximum point value and its stimulus within the specified range. (Query only)

Syntax OUTPMAX?

Query *MAX, f_{max}*

Response Where,

Register	Parameter	Description
0	<i>MAX</i>	Maximum value
1	<i>f_{max}</i>	Stimulus at maximum point (Frequency or Power)

Examples For External Controller

```
OUTPUT @Hp4396;"OUTPMAX?"
ENTER @Hp4396;Max_value,F_max
PRINT Max_value,F_max
```

For Instrument BASIC

```
EXECUTE "OUTPMAX?"
PRINT READIO(8,0),READIO(8,1)
```

OUTPMIN?

Returns the minimum point value and its stimulus within the specified range. (Query only)

Syntax OUTPMIN?

Query *MIN, f_{min}*

Response Where,

Register	Parameter	Description
0	<i>MIN</i>	Minimum value
1	<i>f_{min}</i>	Stimulus at minimum point (Frequency or Power)

OUTPMINMAX?

Returns the maximum and minimum values and their stimulus values within the specified range. (Query only)

Syntax OUTPMINMAX?

Query *MIN, f_{min}, MAX, f_{max}*

Response Where,

Register	Parameter	Description
0	<i>MIN</i>	Minimum value
1	<i>f_{min}</i>	Stimulus at minimum point (Frequency or Power)
2	<i>MAX</i>	Maximum value
3	<i>f_{max}</i>	Stimulus at maximum point (Frequency or Power)

Examples For External Controller

```
OUTPUT @Hp4396;"OUTPMINMAX?"
ENTER @Hp4396;Min_value,F_min,Max_value,F_max
PRINT "MIN:",Min_value,F_min
PRINT "MAX:",Max_value,F_max
```

For Instrument BASIC

```
EXECUTE "OUTPMINMAX?"
PRINT "MIN:",READIO(8,0),READIO(8,1)
PRINT "MAX:",READIO(8,2),READIO(8,3)
```

OUTPMEAN?

Returns the mean value within the specified range. (Query only)

Syntax OUTPMEAN?

Query *mean*

Response Where,

Register	Parameter	Description
0	<i>mean</i>	Mean value.

Examples For External Controller

```
OUTPUT @Hp4396;"OUTPMEAN?"
ENTER @Hp4396;Mean
PRINT Mean
```

For Instrument BASIC

```
EXECUTE "OUTPMEAN?"
PRINT READIO(8,0)
```

PEAK?

Returns maximum peak and its stimulus within the specified range. (Query only)

Syntax PEAK?

Query $MAX_{peak}, f_{maxpeak}$

Response Where,

Register	Parameter	Description
0	MAX_{peak}	Maximum peak value
1	$f_{maxpeak}$	Stimulus at maximum peak

Semantics ■ The analyzer defines the searched value and point as a reference point for the next NEXPK? command. The reference point is stored using **SAVE** ALL or **STATE ONLY**.

Note ■ If the search fails, the analyzer returns 0,0.

Examples For External Controller

```
OUTPUT @Hp4396;"PEAK?"
ENTER @Hp4396;Peak,F_maxpeak
PRINT "Peak:",Peak,"[dB]","F_maxpeak,"[Hz]"
```

For Instrument BASIC

```
EXECUTE "PEAK?"
PRINT "Peak:",READIO(8,0),"[dB]","READIO(8,1),"[Hz]"
```

NEXPK?

Returns the maximum peak having a value less than the value that was found using last PEAK? or NEXPK? command within the specified range. It also returns the corresponding stimulus value. (Query only)

Syntax NEXPK?

Query *Peak, f_{Peak}*

Response Where,

Register	Parameter	Description
0	<i>Peak</i>	Searched peak value
1	<i>f_{Peak}</i>	Searched stimulus

Note

- The analyzer defines the searched value and point as a reference point for the next NEXPK? command. The reference point is stored using **SAVE ALL** or **STATE ONLY**.
- If the multiple corresponded points are found, the analyzer returns right-hand nearest peak of the reference point.
- If the search fails, the analyzer returns 0,0.

Examples For External Controller

```
OUTPUT @Hp4396;"NEXPK?"  
ENTER @Hp4396;N_peak,F_npeak  
PRINT N_peak,F_npeak
```

For Instrument BASIC

```
EXECUTE "PEAK?"  
I=1  
REPEAT  
  PRINT I,READIO(8,0),READIO(8,1)  
  EXECUTE "NEXPK?"  
  I=I+1  
UNTIL READIO(8,0)=0
```

NUMLMAX?

Returns the number of positive peaks within the specified range. (Query only)

Syntax NUMLMAX?

Query n

Response Where,

Register	Parameter	Description
0	n	Number of peaks

Note ■ If the search fails, the analyzer returns 0.

Examples For External Controller

```
OUTPUT @Hp4396;"NUMLMAX?"
ENTER @Hp4396;N
PRINT N
```

For Instrument BASIC

```
EXECUTE "NUMLMAX?"
PRINT READIO(8,0)
```

NUMLMIN?

Returns the number of negative peaks within the specified range. (Query only)

Syntax NUMLMIN?

Query n

Response Where,

Register	Parameter	Description
0	n	Number of negative peaks

Note ■ If the search fails, the analyzer returns 0.

LMAX?

Returns the n th positive peak counted from the left end of the range.

Syntax LMAX? n

Where,

Register	Parameter	Description
0	n	Peak counted from the left end of the range.

Query $LMAX_n$

Response Where,

Register	Parameter	Description
0	$LMAX_n$	Value of n th peak

Note ■ If the search fails, the analyzer returns 3.40282346639E+38.

Examples For External Controller

```
OUTPUT @Hp4396;"LMAX? 5"  
ENTER @Hp4396;Lmax  
PRINT Lmax
```

For Instrument BASIC

```
INPUT "?",N  
WRITEIO 8,0;N  
EXECUTE "LMAX?"  
PRINT READIO(8,0)
```

LMIN?

Returns the n th negative peak counted from the left end of the range.

Syntax LMIN? n

Where,

Register	Parameter	Description
0	n	Negative peak counted from the left end of the range.

Query $LMIN_n$

Response Where,

Register	Parameter	Description
0	$LMIN_n$	Value of n th negative peak

Note ■ If the search fails, the analyzer returns 3.40282346639E+38.

TARR?

Searches to the right for the point having the specified parameter-value from the left end of the range, and returns its stimulus.

Syntax TARR? *target*

Where,

Register	Parameter	Description
0	<i>target</i>	Search value.

Query *f_{target}*

Response

Where,

Register	Parameter	Description
0	<i>f_{target}</i>	Stimulus of the first point found.

Note ■ If the search fails, the analyzer returns 0.

Examples For External Controller

```
INPUT "Enter Target Value.",Target
OUTPUT @Hp4396;"TARR? ";Target
ENTER @Hp4396;F_target
PRINT F_target
```

For Instrument BASIC

```
INPUT "Enter Target Value.",Target
WRITEIO 8,0;Target
EXECUTE "TARR?"
PRINT READIO(8,0)
```

TARL?

Searches to the left for the point having the specified parameter-value from the right end of the range, and returns its stimulus.

Syntax TARL? *target*

Where,

Register	Parameter	Description
0	<i>target</i>	Search value.

Query *f_{target}*

Response Where,

Register	Parameter	Description
0	<i>f_{target}</i>	Stimulus of the first point found.

Note ■ If the search fails, the analyzer returns 0.

Ripple Analysis Commands

Ripple analysis commands analyze the ripples of the waveform and return the results.

- RPLPP?
- RPLHEI?
- RPLRHEI?
- RPLLHEI?
- RPLENV?
- RPLMEA?
- RPLVAL?
- POLE?

RPLPP?

Returns the maximum difference between the positive peak and the negative peak within the specified range. (Query only)

Syntax RPLPP?

Query MAX_{diff}

Response Where,

Register	Parameter	Description
0	MAX_{diff}	Maximum difference between positive and negative peak.

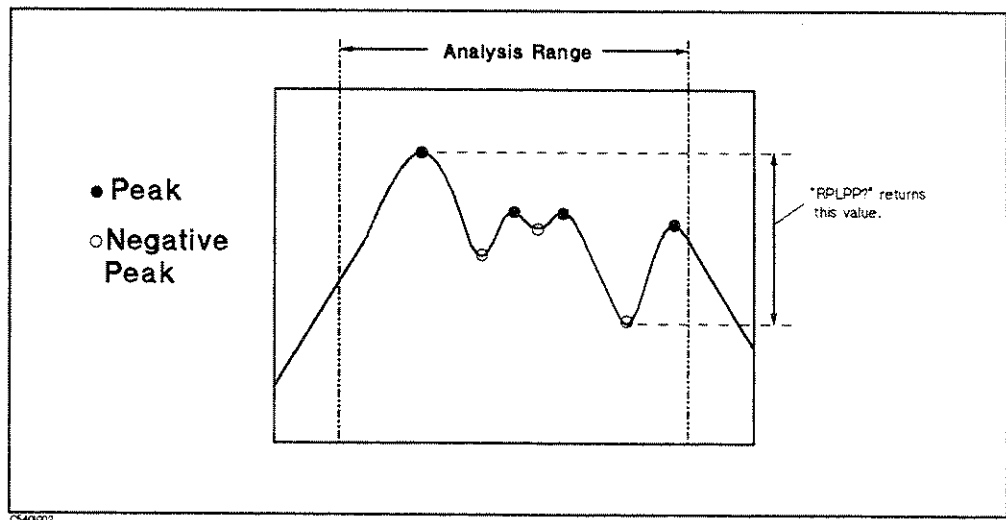

Figure I-2. RPLPP?

Note ■ If the search fails, the analyzer returns 0.

Examples For External Controller

```

ASSIGN @Hp4396 TO 717
OUTPUT @Hp4396;"ANAOCH1;ANARFULL;ANAODATA"
OUTPUT @Hp4396;"RPLPP?"
ENTER @Hp4396;Max_diff
PRINT Max_diff;"[dB]"
END

```

For Instrument BASIC

```
EXECUTE "ANAOCH1"  
EXECUTE "ANARFULL"  
EXECUTE "ANAODATA"  
EXECUTE "RPLPP?"  
PRINT READIO(8,0); "[dB]"  
END
```

RPLHEI?

Returns the maximum difference between adjacent positive and negative peaks. (Query only)

Syntax RPLHEI?

Query *value*

Response Where,

Register	Parameter	Description
0	<i>value</i>	Maximum difference between adjacent positive and negative peaks.

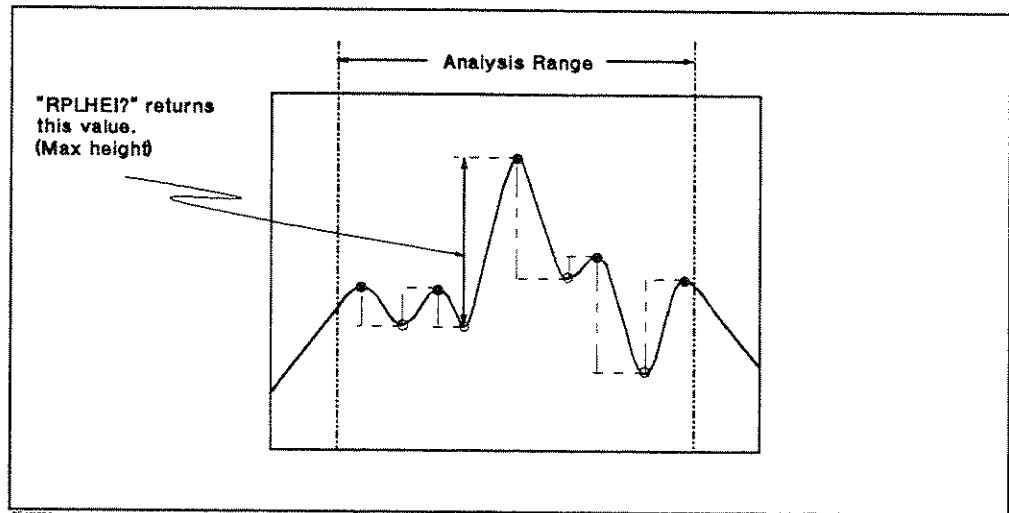

Figure I-3. RPLHEI?

Note ■ If the search fails, the analyzer returns 0.

Examples For External Controller

```
ASSIGN @Hp4396 TO 717
OUTPUT @Hp4396;"ANAOCH1;ANARFULL;ANAODATA"
OUTPUT @Hp4396;"RPLHEI?"
ENTER @Hp4396;Adj_diff
PRINT Adj_diff;"[dB]"
END
```

For Instrument BASIC

```
EXECUTE "ANAOCH1"
EXECUTE "ANARFULL"
EXECUTE "ANAODATA"
EXECUTE "RPLHEI?"
PRINT READIO(8,0);"[dB]"
END
```

RPLRHEI?

Returns the maximum difference between the positive peak and the right-hand adjacent negative peak. (Query only)

Syntax RPLRHEI?

Query *value*

Response Where,

Register	Parameter	Description
0	<i>value</i>	Maximum difference between the positive peak and the right-hand adjacent negative peak.

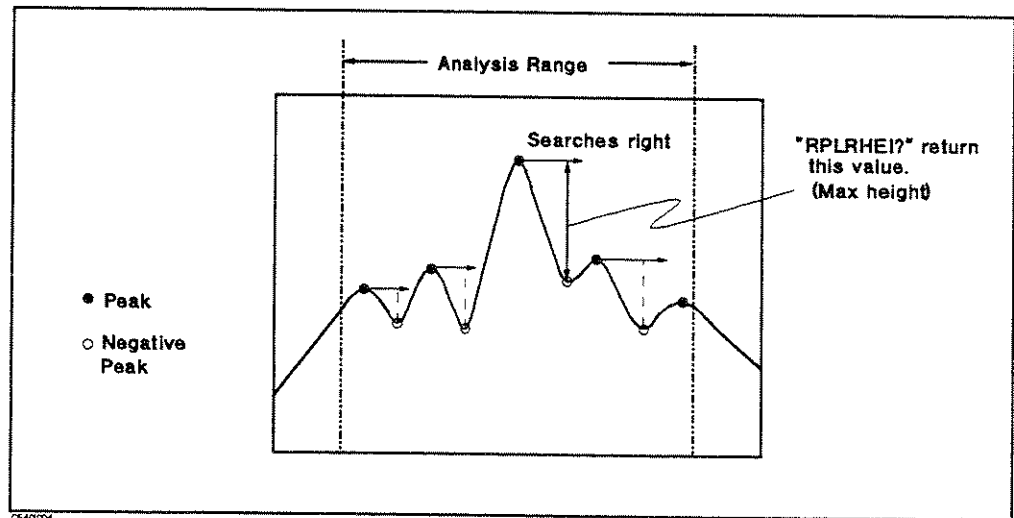

Figure I-4. RPLRHEI?

Note ■ If the search fails, the analyzer returns 0.

Examples For External Controller

```
ASSIGN @Hp4396 TO 717
OUTPUT @Hp4396;"ANAOCH1;ANARFULL;ANAODATA"
OUTPUT @Hp4396;"RPLRHEI?"
ENTER @Hp4396;Adj_diff
PRINT Adj_diff;"[dB]"
END
```

For Instrument BASIC

```
EXECUTE "ANAOCH1"
EXECUTE "ANARFULL"
EXECUTE "ANAODATA"
EXECUTE "RPLRHEI?"
PRINT READIO(8,0);"[dB]"
END
```

RPLLHEI?

Returns the maximum difference between the positive peak and the left-hand adjacent negative peak. (Query only)

Syntax RPLLHEI?

Query *value*

Response Where,

Register	Parameter	Description
0	<i>value</i>	Maximum difference between the positive peak and the left-hand adjacent negative peak.

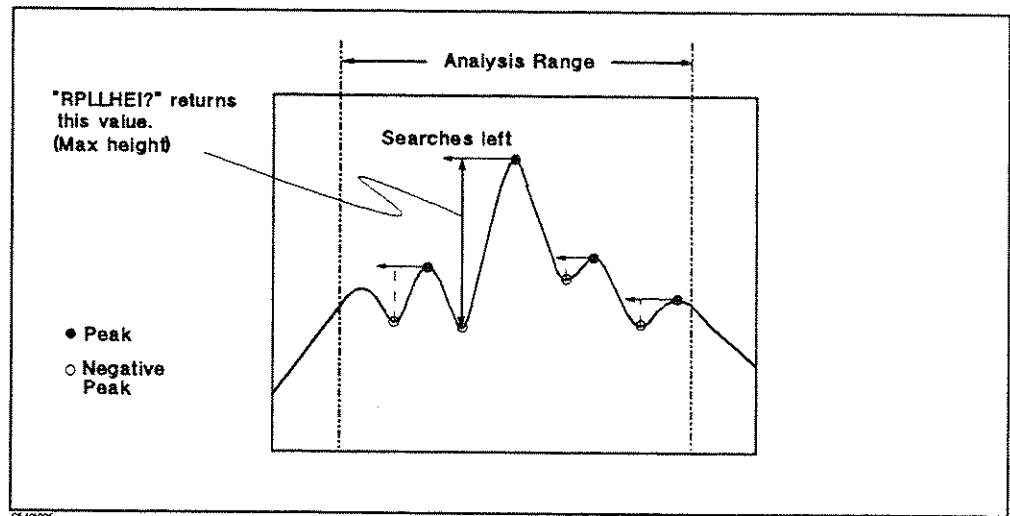

Figure I-5. RPLLHEI?

Note ■ If the search fails, the analyzer returns 0.

Examples For External Controller

```
ASSIGN @Hp4396 TO 717
OUTPUT @Hp4396;"ANAOCH1;ANARFULL;ANAODATA"
OUTPUT @Hp4396;"RPLLHEI?"
ENTER @Hp4396;Adj_diff
PRINT Adj_diff;"[dB]"
END
```

For Instrument BASIC

```
EXECUTE "ANAOCH1"
EXECUTE "ANARFULL"
EXECUTE "ANAODATA"
EXECUTE "RPLLHEI?"
PRINT READIO(8,0);"[dB]"
END
```

RPLENV?

Returns the maximum height between the negative peak and the intersection of an imaginary slope line between the adjacent positive peaks. (Query only)

Syntax RPLENV?

Query *value*

Response Where,

Register	Parameter	Description
0	<i>value</i>	Maximum height between the negative peak and the intersection of an imaginary slope line between the adjacent positive peaks. (See Figure I-6.)

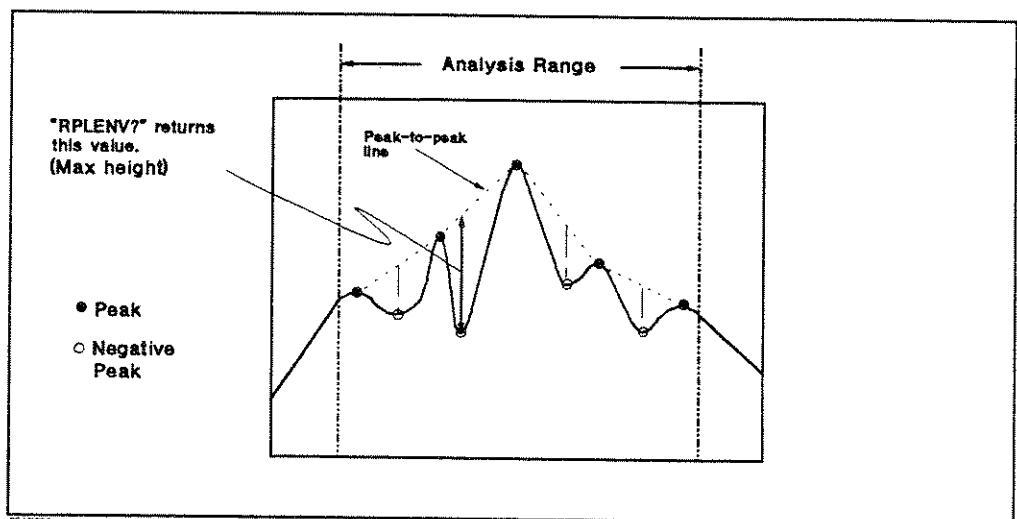

Figure I-6. RPLENV?

Note ■ If the search fails, the analyzer returns 0.

Examples For External Controller

```
ASSIGN @Hp4396 TO 717
OUTPUT @Hp4396;"ANAOCH1;ANARFULL;ANAODATA"
OUTPUT @Hp4396;"RPLENV?"
ENTER @Hp4396;Env_diff
PRINT Env_diff;"[dB]"
END
```

For Instrument BASIC

```
EXECUTE "ANAOCH1"
EXECUTE "ANARFULL"
EXECUTE "ANAODATA"
EXECUTE "RPLENV?"
PRINT READIO(8,0);"[dB]"
END
```

RPLMEA?

Returns the mean of the difference between the adjacent positive and negative peaks within the specified range. (Query only)

Syntax RPLMEA?

Query *value*

Response Where,

Register	Parameter	Description
0	<i>value</i>	Mean of the difference between the adjacent positive and negative peaks. (See Figure I-7)

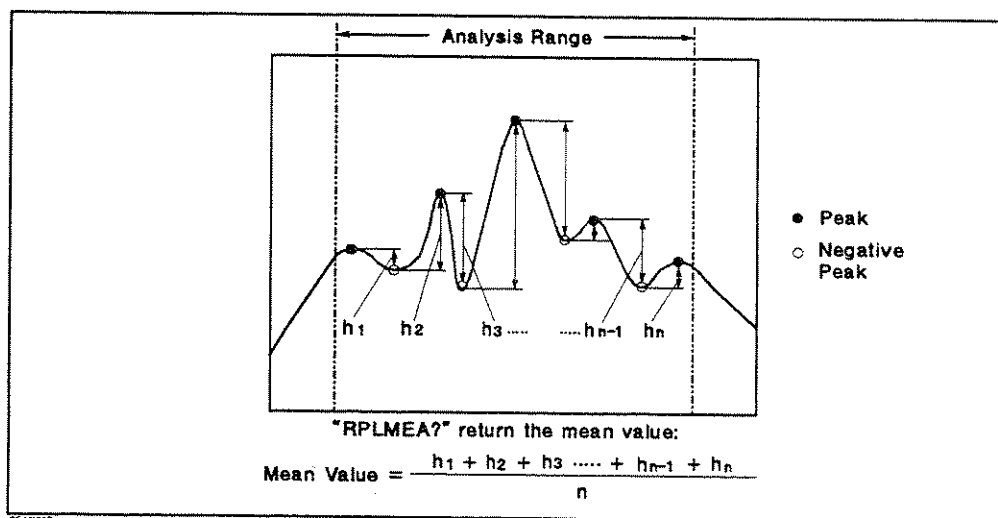

Figure I-7. RPLMEA?

Note ■ If the search fails, the analyzer returns 0.

Examples For External Controller

```
ASSIGN @Hp4396 TO 717
OUTPUT @Hp4396;"ANAOCH1;ANARFULL;ANAODATA"
OUTPUT @Hp4396;"RPLMEA?"
ENTER @Hp4396;Mean_diff
PRINT Mean_diff;"[dB]"
END
```

For Instrument BASIC

```
EXECUTE "ANAOCH1"
EXECUTE "ANARFULL"
EXECUTE "ANAODATA"
EXECUTE "RPLMEA?"
PRINT READIO(8,0);"[dB]"
END
```

RPLVAL?

Returns the maximum total of the differences between the negative peaks and the adjacent positive peaks on both sides and the stimulus of the corresponding negative peak. (Query only)

Syntax RPLVAL?

Query *Rplval, stimulus*

Response Where,

Register	Parameter	Description
0	<i>Rplval</i>	Maximum total of the differences between the negative peaks and the adjacent positive peaks on both sides. (See Figure I-8)
1	<i>stimulus</i>	Stimulus of the corresponding negative peak

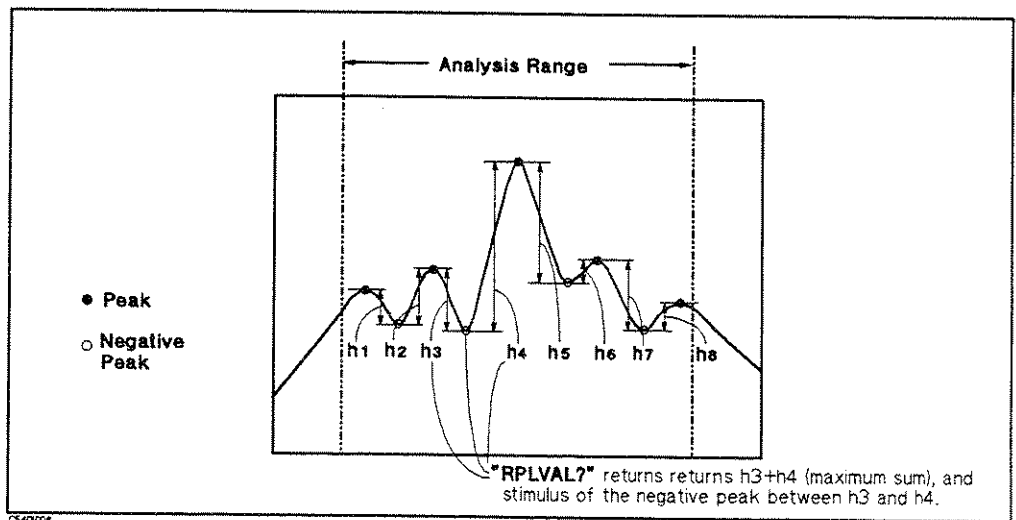

Figure I-8. RPLVAL?

Note ■ If the search fails, the analyzer returns 0.

Examples For External Controller

```
ASSIGN @Hp4396 TO 717
OUTPUT @Hp4396;"ANAOCH1;ANARFULL;ANAODATA"
OUTPUT @Hp4396;"RPLVAL?"
ENTER @Hp4396;Val,Stim
PRINT Val;"[dB]";Stim;"[Hz]"
END
```

For Instrument BASIC

```
EXECUTE "ANAOCH1"
EXECUTE "ANARFULL"
EXECUTE "ANAODATA"
EXECUTE "RPLVAL?"
PRINT READIO(8,0);"[dB]"
PRINT READIO(8,1);"[Hz]"
END
```

POLE?

Returns the stimulus and value of the first negative peak found on each side of the maximum point that are below the specified value from the maximum peak. (Query only)

Syntax POLE? *D*

Where,

Register	Parameter	Description
0	<i>D</i>	Difference from the maximum peak.

Query Response $x_1, stim_1, x_2, stim_2$

Where,

Register	Parameter	Description
0	x_1	Left negative peak value.
1	$stim_1$	Stimulus of x_1 .
2	x_2	Right negative peak value.
3	$stim_2$	Stimulus of x_2 .

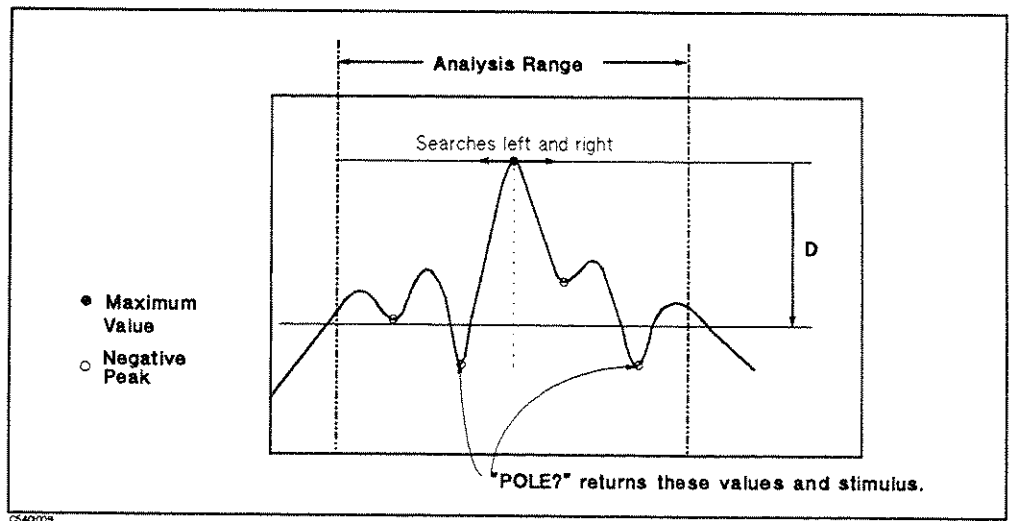

Figure I-9. POLE?

Note

- If the search fails, the analyzer returns 0.
- Give the command parameter as a negative value. For instance, to specify 50 dB down from the maximum peak as a reference level, the parameter is -50.

Examples For External Controller

```

ASSIGN @Hp4396 TO 717
OUTPUT @Hp4396;"ANAOCH1;ANARFULL;ANAODATA"
OUTPUT @Hp4396;"POLE? -50"
ENTER @Hp4396;X1,S1,X2,S2
PRINT "LEFT :";X1;"[dB]";S1;"[Hz]"
PRINT "RIGHT:";X2;"[dB]";S2;"[Hz]"
    
```

END

For Instrument BASIC

```
EXECUTE "ANAOCH1"  
EXECUTE "ANARFULL"  
EXECUTE "ANAODATA"  
WRITEIO 8,0;-50  
EXECUTE "POLE?"  
PRINT "LEFT :";READIO(8,0);"[dB]";READIO(8,1);"[Hz]"  
PRINT "RIGHT: ";READIO(8,2);"[dB]";READIO(8,3);"[Hz]"  
END
```

Filter and Resonator Analysis Commands

The following commands are device related. They are easy to use for specific device analysis because they can output many parameters using only a single command.

- **OUTPFILT?**
- **OUTPXFIL?**
- **OUTPCFIL?**
- **OUTPRESO?**
- **OUTPRESR?**
- **OUTPRESF?**
- **OUTPCERR?**

OUTPFILT?

Analyzes the filter and returns the parameters.

Syntax OUTPFILT? *x*

Where,

Register	Parameter	Description
0	<i>x</i>	The dB value down the bandwidth filter.

Query Response *Loss, BW, f_{cent}, Q, Δf_{left}, Δf_{right}* (Total6)

Register	Parameter	Description
0	<i>Loss</i>	Insertion loss
1	<i>BW</i>	<i>x</i> dB down bandwidth
2	<i>f_{cent}</i>	Center frequency
3	<i>Q</i>	Q (Quality factor)
4	<i>Δf_{left}</i>	Frequency difference between the left cutoff point and the middle of the range.
5	<i>Δf_{right}</i>	Frequency difference between the right cutoff point and the middle of the range.

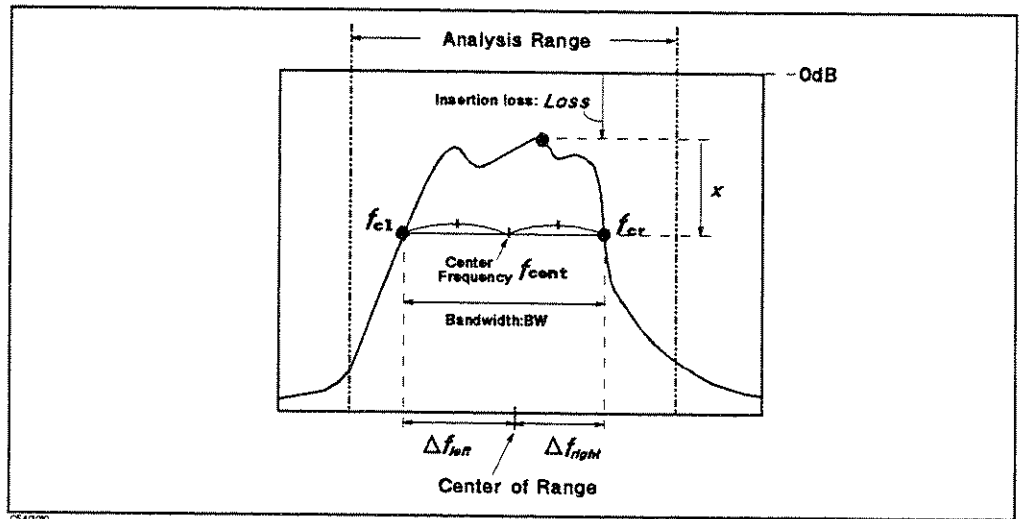

Figure I-10. OUTPFILT?

- Semantics**
- Insertion loss is the maximum value within the specified range.
 - *x* dB bandwidth is the frequency difference between both of the *x*dB down cutoff points.
 - Center frequency is the middle point of both cutoff points.
 - Q is calculated using the following equation:

$$Q = \frac{\sqrt{f_{cl} \times f_{cr}}}{BW}$$

Note

- If both of the two cutoff points are not found, the analyzer returns 0 for all values of the query response.

Examples For External Controller

```
10 ASSIGN @Hp4396 TO 717
20 CALL Sweep(1) ! Goes to the subroutine.
30 OUTPUT @Hp4396;"ANAOCH1;ANARFULL;ANAODATA"
40 OUTPUT @Hp4396;"OUTPFILT? -3"
50 ENTER @Hp4396;Loss,Bw,Fc,Q,Dfl,Dfr
60 PRINT "Loss: ";Loss;"[dB] BW: ";Bw;"[Hz]"
70 PRINT "fc: ";Fc;"[Hz] Q: ";Q
80 PRINT "Dfl: ";Dfl;"[Hz] Dfr: ";Dfr;"[Hz]"
90 END

100 SUB Sweep(Ch)! Sweep End Detection Subroutine
101      ! (Parameter: No. of channel)
110  ASSIGN @Hp4396 TO 717
120  ON INTR 7 GOTO Sweep_end
130  OUTPUT @Hp4396;"TRGS BUS"
140  OUTPUT @Hp4396;"ESNB 2; *SRE 4"
150  FOR I=1 TO Ch
160    OUTPUT @Hp4396;"*CLS;*OPC?"
170    ENTER @Hp4396;Opc
180    ENABLE INTR 7;2
190    TRIGGER @Hp4396
200    Waiting:GOTO Waiting
210    Sweep_end:!
220  NEXT I
230  SUBEND
```

For Instrument BASIC

```
10 ASSIGN @Hp4396 TO 800
20 OUTPUT @Hp4396;"CENT 70MHZ; SPAN 100KHZ"
30 EXECUTE "SING"
40 EXECUTE "ANAOCH1"
50 EXECUTE "ANARFULL"
60 EXECUTE "ANAODATA"
70 WRITEIO 8,0;-50
80 EXECUTE "POLE?"
90 PRINT "Loss: ";READIO(8,0);"[dB] BW: ";READIO(8,1);"[Hz]"
100 PRINT "fc: ";READIO(8,2);"[Hz] Q: ";READIO(8,3)
110 PRINT "Dfl: ";READIO(8,4);"[Hz] Dfr: ";READIO(8,5);"[Hz]"
120 END
```

OUTPXFIL?

Syntax OUTPXFIL? x_1, x_2, D, f_1, f_2

Where,

Register	Parameter	Description
0	x_1	The dB value down the bandwidth filter. (1) x_1 [dB]
1	x_2	The dB value down the bandwidth filter. (2) x_2 [dB]
2	D	Difference from maximum value. (Same as POLE? parameter.)
3	f_1	Stop frequency of the range for the rejection level.
4	f_2	Start frequency of the range for the spurious level.

Query *Loss, BW, fcent, Q, Δfleft1, Δfright1, Δfleft2, Δfright2, Pass, Reject, Spurious, Pole_{x1}, Pole_{stim1}, Pole_{x2}, Pole_{stim2}* (15)

Response

Register	Parameter	Description
0	<i>Loss</i>	Insertion loss
1	<i>BW</i>	x_1 dB down bandwidth
2	<i>fcent</i>	Center frequency
3	<i>Q</i>	Q
4	Δf_{left}	Frequency difference between the left cutoff point (f_{cl}) and the middle of the range.
5	Δf_{right}	Frequency difference between the right cutoff point (f_{cr}) and the middle of the range.
6	Δf_{left2}	Frequency difference between the left cutoff point (f_{cl2}) and the middle of the range.
7	Δf_{right2}	Frequency difference between the left cutoff point (f_{cr2}) and the middle of the range.
8	<i>Pass</i>	Passband ripple
9	<i>Reject</i>	Rejection level
10	<i>Spurious</i>	Spurious level
11	<i>Pole_{x1}</i>	First negative peak found to the left of the maximum point.
12	<i>Pole_{stim1}</i>	Stimulus of <i>Pole_{x1}</i> .
13	<i>Pole_{x2}</i>	First negative peaks found to the right of the maximum point.
14	<i>Pole_{stim2}</i>	Stimulus of <i>Pole_{x2}</i> .

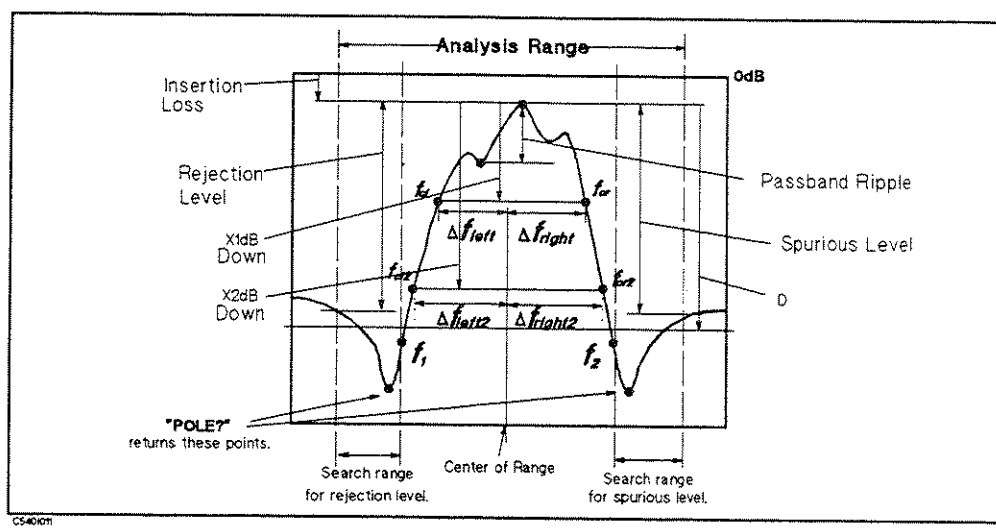

Figure I-11. OUTPXFIL?

- Semantics**
- Insertion loss, x_1 dB bandwidth, center frequency, Q , Δf_{left} , and Δf_{right} are the same as the responses of OUTPFILT?.
 - Δf_{left2} and Δf_{right2} are the frequency differences between both sides at the x_2 dB down cutoff points (f_{cl2} and f_{cr2}) and the middle of the range.
 - Passband ripple is the frequency difference of the maximum positive peak and the minimum negative peak between the x_1 dB down cutoff points (f_{cl} , f_{cr}).
 - Rejection level is the frequency difference from the insertion loss to the maximum level in the range from the left edge of analysis range to f_1 .
 - Spurious level is the frequency difference from the insertion loss to the maximum level between f_2 and the right edge of analysis range.
 - $Pole_{x1}$, $Pole_{stim1}$, $Pole_{x2}$, $Pole_{stim2}$ are the same as the query response of POLE? with the parameter D .
- Note**
- If both of the two x_1 dB down cutoff points are not found, the analyzer returns 0 for all values of the query response.
 - If both of the two x_2 dB down cutoff points are not found, the analyzer returns 0 for Δf_{left2} and Δf_{right2} .
 - If the corresponding peak for POLE? is not found, the analyzer returns 0 for $Pole_{x1}$, $Pole_{stim1}$, $Pole_{x2}$, and $Pole_{stim2}$.

Examples For External Controller

```

10 ASSIGN @Hp4396 TO 717
20 OUTPUT @Hp4396;"CENT 70MHZ; SPAN 100KHZ"
30 CALL Sweep(1) ! Goes to sub routine.
40 OUTPUT @Hp4396;"ANAOCH1;ANARFULL;ANAOADATA"
50 OUTPUT @Hp4396;"OUTPXFIL? -3,-10,-50,69.98MHz,70.02MHz"
60 ENTER @Hp4396;Loss,Bw,Fc,Q,Dfl,Dfr,Dfl2,Dfr2,Pass,Reject,
Spurious,Pole1,Fp1,Pole2,Fp2
70 PRINT "Loss: ";Loss;" [dB] BW: ";Bw;" [Hz] fc: ";Fc;" [Hz]"
80 PRINT "Q: ";Q;" Dfl: ";Dfl;" [Hz] Dfr: ";Dfr;" [Hz]"
90 PRINT "Dfl2: ";Dfl2;" [Hz] Dfr2: ";Dfr2;" [Hz] Pass: ";Pass;" [dB]"
    
```

```
100 PRINT "Reject: ";Reject;"[dB] Spurious: ";Spurious;"[dB]"
110 PRINT "Pole (left): ";Pole1;"[dB] ";Fp1;"[Hz]"
120 PRINT "Pole (right): ";Pole2;"[dB] ";Fp2;"[Hz]"
130 END
```

For Instrument BASIC

```
10 ASSIGN @Hp4396 TO 800
20 OUTPUT @Hp4396;"CENT 70MHZ; SPAN 100KHZ"
30 EXECUTE "SING"
40 EXECUTE "ANAOCH1"
50 EXECUTE "ANARFULL"
60 EXECUTE "ANAODATA"
70 WRITEIO 8,0;-3
80 WRITEIO 8,1;-10
90 WRITEIO 8,2;-50
100 WRITEIO 8,3;6.998E+7
110 WRITEIO 8,4;7.002E+7
120 EXECUTE "OUTPXFIL?"
130 PRINT "Passband Ripple: ";READIO(8,8);"[dB]"
140 PRINT "Rejection Level: ";READIO(8,9);"[dB]"
150 PRINT "Spurious Level: ";READIO(8,10);"[dB]"
160 END
```

OUTPCFIL?

Analyzes the filter at the nominal frequency, and returns the parameters.

Syntax OUTPCFIL? f_c , x_1 , x_2 , D , f_1 , f_2

Where,

Register	Parameter	Description
0	f_c	Nominal frequency
1	x_1	The dB value down the bandwidth filter. (1) x_1 [dB]
2	x_2	The dB value down the bandwidth filter. (2) x_2 [dB]
3	D	Difference from maximum value. (Same as POLE? parameter.)
4	f_1	Stop frequency of the range for the rejection level.
5	f_2	Start frequency of the range for the spurious level.

Query Response $Loss$, $Loss_c$, BW , f_{cent} , Q , Δf_{left1} , Δf_{right1} , Δf_{left2} , Δf_{right2} , $Pass$, $Reject$, $Spurious$, $Pole_{x1}$, $Pole_{stim1}$, $Pole_{x2}$, $Pole_{stim2}$ (Total 16)

Register	Parameter	Description
0	$Loss$	Insertion loss
1	$Loss_c$	Const Loss
2	BW	x_1 dB down bandwidth
3	f_{cent}	Center frequency
4	Q	Q
5	Δf_{left}	Frequency difference between the left cutoff point (f_{cl}) and the middle of the range.
6	Δf_{right}	Frequency difference between the right cutoff point (f_{cr}) and the middle of the range.
7	Δf_{left2}	Frequency difference between the left cutoff point (f_{cl2}) and the middle of the range.
8	Δf_{right2}	Frequency difference between the left cutoff point (f_{cr2}) and the middle of the range.
9	$Pass$	Passband ripple
10	$Reject$	Rejection level
11	$Spurious$	Spurious level
12	$Pole_{x1}$	First negative peaks found to the left of the maximum point.
13	$Pole_{stim1}$	Stimulus of $Pole_{x1}$.
14	$Pole_{x2}$	First negative peak found to the right of the maximum point.
15	$Pole_{stim2}$	Stimulus of $Pole_{x2}$.

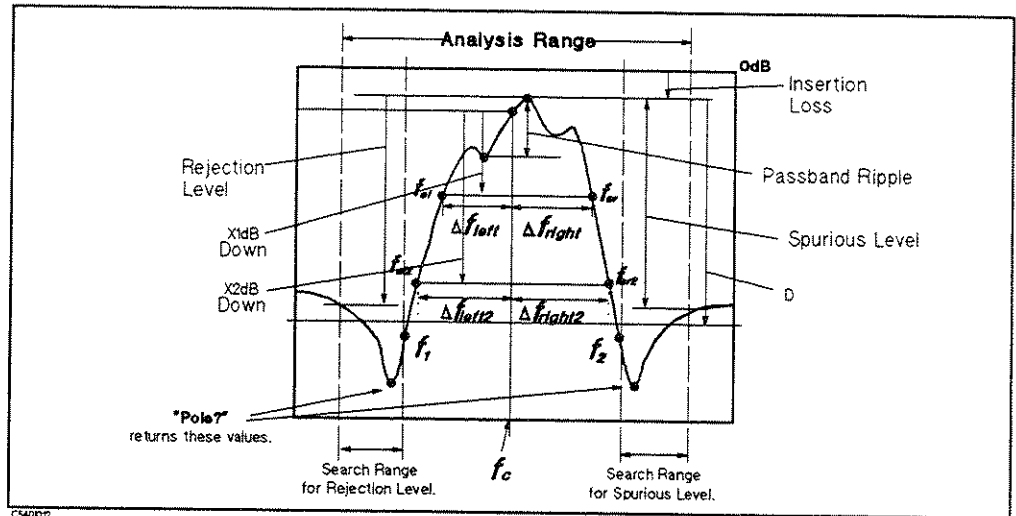

Figure I-12. OUTPCFIL?

- Semantics**
- Insertion loss, rejection level, spurious level, $Pole_{x1}$, $Pole_{stim1}$, $Pole_{x2}$, and $Pole_{stim2}$ are the same as the responses of OUTPCFIL?
 - The const loss is the value of the point that is specified by command parameter, f_c .
 - x_1 dB bandwidth is the frequency difference between two x_1 dB down cutoff points (f_{cl} , f_{cr}) from the const loss point.
 - Center frequency is the middle point of f_{cl} and f_{cr} .
 - Q is calculated using the following equation:

$$Q = \frac{\sqrt{f_{cl} \times f_{cr}}}{BW}$$

- Δf_{left} and Δf_{right} are the frequency differences between both sides at the x_1 dB down cutoff points (f_{cl} and f_{cr}) and f_c .
 - Δf_{left2} and Δf_{right2} are the frequency differences between both sides at the x_2 dB down cutoff points (f_{cl2} and f_{cr2}) and f_c .
 - Passband ripple is the frequency difference of maximum positive peak and minimum negative peak between x_1 dB down cutoff points (f_{cl1} , f_{cr1}).
- Note**
- If both of the two x_1 dB down cutoff points are not found, the analyzer returns 0 for all values of the query response.
 - If both of the two x_2 dB down cutoff points are not found, the analyzer returns 0 for Δf_{left2} and Δf_{right2} .
 - If the corresponding peak for POLE? is not found, the analyzer returns 0 for $Pole_{x1}$, $Pole_{stim1}$, $Pole_{x2}$, and $Pole_{stim2}$.

Examples For External Controller

```

10 ASSIGN @Hp4396 TO 717
20 OUTPUT @Hp4396;"CENT 70MHZ; SPAN 100KHZ"
30 CALL Sweep(1) ! Goes to sub routine. (See OUTPCFIL?)
40 OUTPUT @Hp4396;"ANAOCH1;ANARFULL;ANAODATA"

```

```
50 OUTPUT @Hp4396;"OUTPCFIL? 70MHz,-3,-10,-50,69.98MHz,70.02MHz"
60 ENTER @Hp4396;Loss,Lc,Bw,Fc,Q,Df1,Dfr,Df12,Dfr2,Pass,Reject,
Spurious,Pole1,Fp1,Pole2,Fp2
70 PRINT "Loss: ";Loss;" [dB] Const Loss: ";Lc;" [dB] "
80 PRINT "BW: ";Bw;" [Hz] Fc: ";Fc;" [Hz] "
90 PRINT "Q: ";Q;" DF1: ";Df1;" [Hz] DFr: ";Dfr;" [Hz] "
100 PRINT "Df12: ";Df12;" [Hz] Dfr2: ";Dfr2;" [Hz] Pass: ";Pass;" [dB] "
110 PRINT "Reject: ";Reject;" [dB] Spurious: ";Spurious;" [dB] "
120 PRINT "Pole (left): ";Pole1;" [dB] ";Fp1;" [Hz] "
130 PRINT "Pole (right): ";Pole2;" [dB] ";Fp2;" [Hz] "
140 END
```

For Instrument BASIC

```
10 ASSIGN @Hp4396 TO 800
20 OUTPUT @Hp4396;"CENT 70MHZ; SPAN 100KHZ"
30 EXECUTE "SING"
40 EXECUTE "ANAOCH1"
50 EXECUTE "ANARFULL"
60 EXECUTE "ANAODATA"
70 WRITEIO 8,0;7.E+7
80 WRITEIO 8,1;-3
90 WRITEIO 8,2;-10
100 WRITEIO 8,3;-50
110 WRITEIO 8,4;6.998E+7
120 WRITEIO 8,5;7.002E+7
130 EXECUTE "OUTPCFIL?"
140 PRINT "Const Loss: ";READIO(8,1);" [dB] "
150 END
```

OUTPRESO?

Returns resonator specific parameters. (Query only)

Syntax OUTPRESO?

Query Z_r, f_r, Z_a, f_a (Total 4)

Response Where,

Register	Parameter	Description
0	Z_r	Resonant impedance
1	f_r	Resonant frequency
2	Z_a	Anti-resonant impedance
3	f_a	Anti-resonant frequency

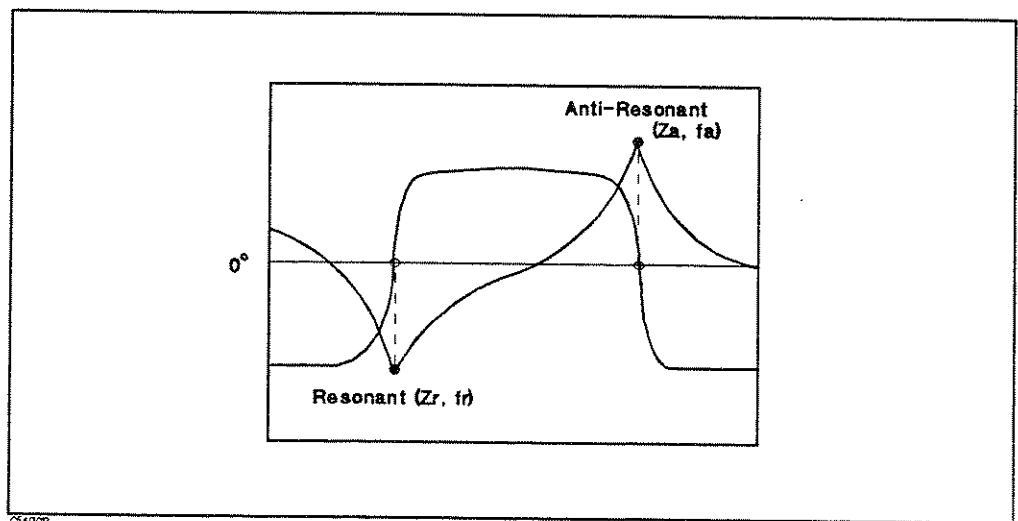

Figure I-13. OUTPRESO?

- Semantics** ■ OUTPRESO? executes the following actions and returns their values:
1. Searches for the 0° phase point from the left edge of the analysis range.
 2. Defines the first point found as the resonant point, and then returns its impedance and its frequency.
 3. Defines the next point found as the anti-resonant point, and then returns its impedance and its frequency.
- Note** ■ You must select the following conditions to use this command:
- Dual Channel & Coupled Channel: ON
 - Impedance Conversion: ON
 - Analysis channel: LOG MAG format
 - Non-analysis channel: Phase format
- OUTPRESO? returns the first two found 0° phase point events if there are more than three corresponding points.
- If there is only one 0° phase point in the range, OUTPRESO? defines that point as a resonant point and returns 0 for Z_a and f_a .

- If there is no 0° point, OUTPRES0? returns 0 for all parameters.
- If the impedance conversion is off, OUTPRES0? returns the magnitude (dB) at the 0° phase point.

Examples For External Controller

```

10 ASSIGN @Hp4396 TO 717
20 OUTPUT @Hp4396;"DUAC ON; COUC ON"
30 OUTPUT @Hp4396;"CHAN2; FMT PHAS"
40 OUTPUT @Hp4396;"CHAN1; FMT LOGM; CONV ZTRA"
50 OUTPUT @Hp4396;"CENT 70MHZ; SPAN 100KHZ"
60 CALL Sweep(2) ! Goes to sub routine. (See OUTPFILT?)
61             ! Parameter is 2 because of Dual Channel ON.
70 OUTPUT @Hp4396;"ANAOCH1;ANARFULL;ANAODATA"
80 OUTPUT @Hp4396;"OUTPRES0?"
90 ENTER @Hp4396;Zr,Fr,Za,Fa
100 PRINT "Resonant: ";Zr;"[ohm] ,";Fr;"[Hz]"
110 PRINT "Anti-Resonant: ";Za;"[ohm] ,";Fa;"[Hz]"
120 END

```

For Instrument BASIC

```

10 ASSIGN @Hp4396 TO 800
20 OUTPUT @Hp4396;"DUAC ON; COUC ON"
30 OUTPUT @Hp4396;"CHAN2; FMT PHAS"
40 OUTPUT @Hp4396;"CHAN1; FMT LOGM; CONV ZTRA"
50 OUTPUT @Hp4396;"CENT 70MHZ; SPAN 100KHZ"
60 EXECUTE "SING" ! This line waits for the end of both channel sweep.
70 EXECUTE "ANAOCH1"
80 EXECUTE "ANARFULL"
90 EXECUTE "ANAODATA"
100 EXECUTE "OUTPRES0?"
110 PRINT "Resonant: ";READIO(8,0);"[ohm] ";READIO(8,1);"[Hz]"
120 PRINT "Anti-Resonant: ";READIO(8,2);"[ohm] ";READIO(8,3);"[Hz]"
130 END

```

OUTPRESR?

Returns the resonator specific parameters. (Query only)

Syntax OUTPRESR?

Query $Z_r, f_r, Z_a, f_a, Rpl_1, Rpl_2, Rpl_3$ (Total 7)

Response Where,

Register	Parameter	Description
0	Z_r	Resonant impedance
1	f_r	Resonant frequency
2	Z_a	Anti-resonant impedance
3	f_a	Anti-resonant frequency
4	Rpl_1	Maximum left height of the ripple where is on the left side of the resonant point.
5	Rpl_2	Maximum height right of the ripple that is between the resonant and anti-resonant points.
6	Rpl_3	Maximum height left of the ripple that is on the right side of the resonant point.

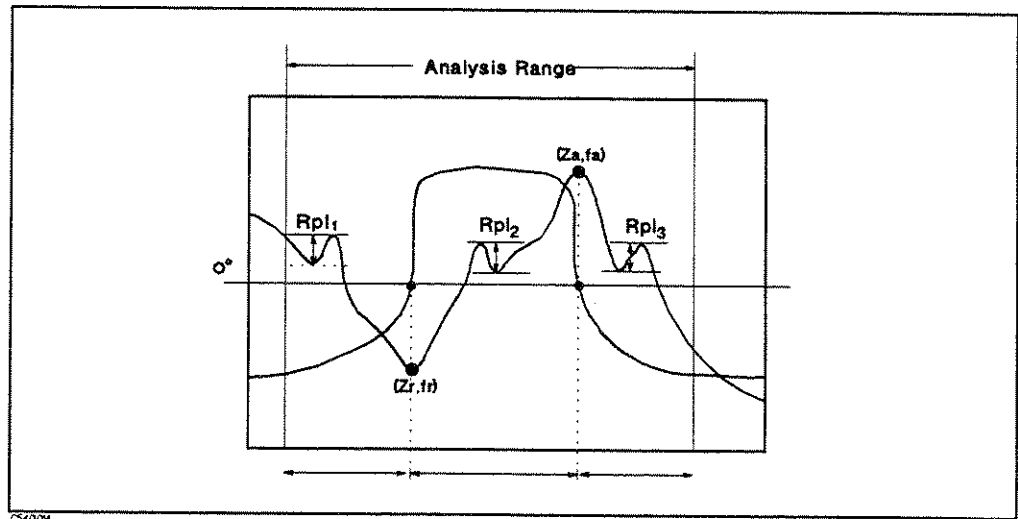

Figure I-14. OUTPRESR?

Semantics ■ OUTPRESR? executes the following actions:

1. Searches for the 0° phase point from the left edge of the analysis range.
2. Defines the first point found as the resonant point, and then returns its impedance and its frequency.
3. Defines the next point found as the anti-resonant point, and then returns its impedance and its frequency.
4. Returns the maximum height of the ripple, Rpl_1 , that is the difference between the peak and left adjacent negative peak.
5. Returns the maximum height of the ripple, Rpl_2 , that is the difference between the peak and right adjacent negative peak.

- Returns the maximum height of the ripple, Rpl_3 , that is the difference between the peak and left adjacent negative peak.

Note

- You must select the following conditions to use this command:
 - Dual Channel & Coupled Channel: ON
 - Impedance Conversion: ON
 - Analysis channel: LOG MAG format
 - Non-analysis channel: Phase format
- OUTPRESR? returns the first two 0° phase point events found if there are more than three corresponding points points.
- If there is only one 0° phase point in the range, OUTPRESR? defines that point as a resonant point and returns 0 for Z_a , f_a , Rpl_1 , Rpl_2 , and Rpl_3 .
- If there is no 0° point, OUTPRESR? returns 0 for all parameters.

Examples For External Controller

```
10 ASSIGN @Hp4396 TO 717
20 OUTPUT @Hp4396;"DUAC ON; COUC ON"
30 OUTPUT @Hp4396;"CHAN2; FMT PHAS"
40 OUTPUT @Hp4396;"CHAN1; FMT LOGM; CONV ZTRA"
50 OUTPUT @Hp4396;"CENT 70MHZ; SPAN 100KHZ"
60 CALL Sweep(2) ! Goes to sub routine. (See OUTPFILT?)
70 OUTPUT @Hp4396;"ANAOCH1;ANARFULL;ANAODATA"
80 OUTPUT @Hp4396;"OUTPRESR?"
90 ENTER @Hp4396;Zr,Fr,Za,fa,R1,R2,R3
100 PRINT "Resonant: ";Zr;"[ohm] ,";Fr;"[Hz]"
110 PRINT "Anti-Resonant: ";Za;"[ohm] ,";fa;"[Hz]"
120 PRINT "Ripple L: ";R1;"[dB]"
130 PRINT "Ripple M: ";R2;"[dB]"
140 PRINT "Ripple R: ";R3;"[dB]"
150 END
```

For Instrument BASIC

```
10 ASSIGN @Hp4396 TO 800
20 OUTPUT @Hp4396;"DUAC ON; COUC ON"
30 OUTPUT @Hp4396;"CHAN2; FMT PHAS"
40 OUTPUT @Hp4396;"CHAN1; FMT LOGM; CONV ZTRA"
50 OUTPUT @Hp4396;"CENT 70MHZ; SPAN 100KHZ"
60 EXECUTE "SING"
70 EXECUTE "ANAOCH1"
80 EXECUTE "ANARFULL"
90 EXECUTE "ANAODATA"
100 EXECUTE "OUTPRESR?"
110 PRINT "Resonant: ";READIO(8,0);"[ohm] ,";READIO(8,1);"[Hz]"
120 PRINT "Anti-Resonant: ";READIO(8,2);"[ohm] ,";READIO(8,3);"[Hz]"
130 PRINT "Ripple L: ";READIO(8,4);"[dB]"
140 PRINT "Ripple M: ";READIO(8,5);"[dB]"
150 PRINT "Ripple R: ";READIO(8,6);"[dB]"
160 END
```

OUTPRESF?

Returns the resonator specific parameters. (Query only)

Syntax OUTPRESF? x_1, x_2

Where,

Register	Parameter	Description
0	x_1	Value down from the maximum peak.
1	x_2	Value above the maximum peak.

Query $f_s, f_p, f_{s1}, f_{s2}, f_{p1}, f_{p2}$ (Total 6)

Response Where,

Register	Parameter	Description
0	f_s	Middle point frequency between f_{s1} and f_{s2} .
1	f_p	Middle point frequency between f_{p1} and f_{p2} .
2	f_{s1}	Left one of the two points x_1 dB down from the maximum peak.
3	f_{s2}	Right one of the two points x_1 dB down from the maximum peak.
4	f_{p1}	Left one of the two points x_2 dB above the minimum negative peak.
5	f_{p2}	Right one of the two points x_2 dB above the minimum negative peak.

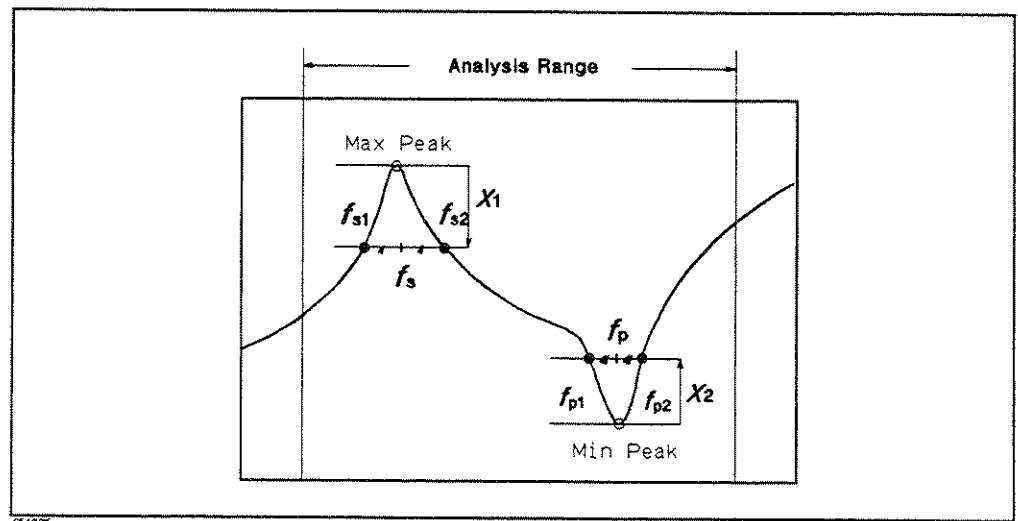

Figure I-15. OUTPRESF?

Semantics ■ OUTPRESF? executes the following actions:

1. Searches for the maximum peak in the analysis range.
2. Searches for the x_1 dB below points on both sides, and defines the first found left and right side points as f_{s1} and f_{s2} , respectively.

3. Defines the middle point between f_{s1} and f_{s2} to f_s .
4. Searches for the x_2 dB above points on both sides, and defines the first found left and right side points as f_{p1} and f_{p2} , respectively.
5. Defines the middle point between f_{p1} and f_{p2} as f_p .

Note

- If there is no corresponding peak in the range, OUTPRESF? returns 0 for all parameters.
- If the maximum peak cannot be found, OUTPRESF? returns 0 for f_s , f_{s1} , and f_{s2} .
- If the minimum negative peak cannot be found, OUTPRESF? returns 0 for f_p , f_{p1} , and f_{p2} .
- Specify the negative value for x_1 and positive value for x_2 .

Examples For External Controller

```

10 ASSIGN @Hp4396 TO 717
20 OUTPUT @Hp4396;"FMT LOGM; CENT 60.06MHz; SPAN 20kHz"
30 CALL Sweep(1) ! Goes to sub routine. (See OUTPFILT?)
40 OUTPUT @Hp4396;"ANAOCH1;ANARFULL;ANAODATA"
50 OUTPUT @Hp4396;"OUTPRESF? -3dB,3dB"
60 ENTER @Hp4396;Fs,Fp,Fs1,Fs2,Fp1,Fp2
70 PRINT "Series-Resonant: ";Fs;" [Hz]"
80 PRINT "Parallel-Resonant: ";Fp;" [Hz]"
90 END

```

For Instrument BASIC

```

10 ASSIGN @Hp4396 TO 800
20 OUTPUT @Hp4396;"FMT LOGM"
30 OUTPUT @Hp4396;"CENT 60.06MHz; SPAN 20kHz"
40 EXECUTE "SING"
50 EXECUTE "ANAOCH1"
60 EXECUTE "ANARFULL"
70 EXECUTE "ANAODATA"
80 WRITEIO 8,0;-3
90 WRITEIO 8,1;3
100 EXECUTE "OUTPRESF?"
110 PRINT "Series-Resonant: ";READIO(8,0);" [Hz]"
120 PRINT "Pararel-Resonant: ";READIO(8,1);" [Hz]"
130 END

```

OUTPCERR?

Returns the ceramic resonator specific parameters. (Query only)

Syntax OUTPCERR?

Query $Z_r, f_r, Z_a, f_a, Rpl_1, Rpl_2, Rpl_3$ (Total7)

Response Where,

Register	Parameter	Description
0	Z_r	Resonant impedance
1	f_r	Resonant frequency
2	Z_a	Anti-resonant impedance
3	f_a	Anti-resonant frequency
4	Rpl_1	Maximum height of the ripple that is on the left side of the resonant point.
5	Rpl_2	Maximum height of the ripple that is between the resonant and anti-resonant points.
6	Rpl_3	Maximum height of the ripple that is on the right side of the resonant point.

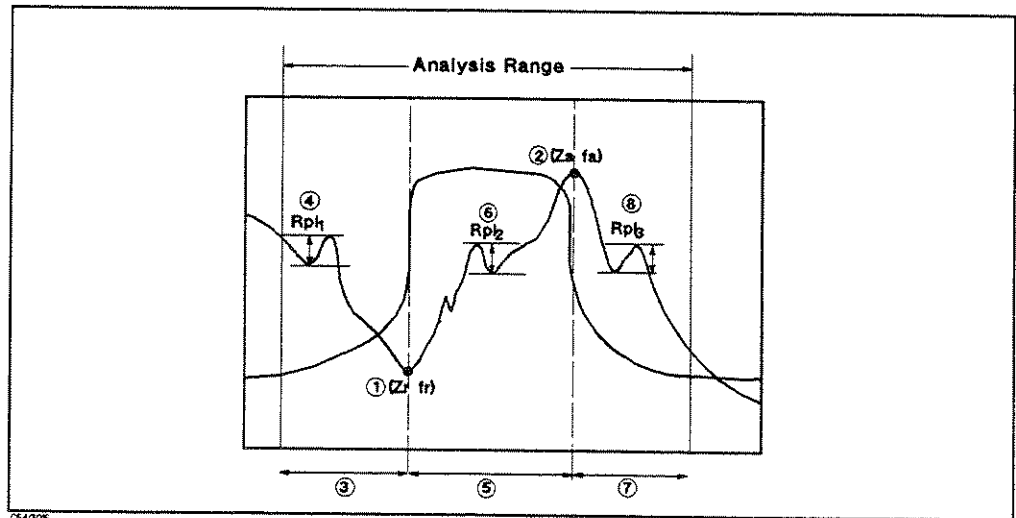

Figure I-16. OUTPCERR?

- Semantics**
- You need to select the LOG MAG format (FMT LOGM) and turn impedance conversion on (CONV ZTRA) to use this command.
 - OUTPCERR? executes the following actions:
 1. Searches for the minimum negative peak in the range and defines it as a resonant point. Then returns the resonant impedance, Z_r , and resonant frequency, f_r .
 2. Searches for the maximum peak in the range and defines it as a anti-resonant point. Then returns the anti-resonant impedance, Z_a , and anti-resonant frequency, f_p .

3. Returns the maximum height of the ripple, Rpl_1 , that is the difference between the peak and left adjacent negative peak.
4. Returns the maximum height of the ripple, Rpl_2 , that is the difference between the peak and right adjacent negative peak.
5. Returns the maximum height of the ripple, Rpl_3 , that is the difference between the peak and left adjacent negative peak.

Note

- This command can be used when the LOG MAG format (FMT LOGM) is selected. If another format is selected, OUTPCERR? returns 0 for all parameters.
- If no corresponding ripple is found, OUTPCERR? returns 0.

Examples

```

10 ASSIGN @Hp4396 TO 717
20 OUTPUT @Hp4396;"FMT LOGM; CONV ZTRA; CENT 60.02MHz; SPAN 20kHz"
30 CALL Sweep(1) ! Goes to sub routine. (See OUTPFILT?)
40 OUTPUT @Hp4396;"ANAOCH1;ANARFULL;ANAODATA"
50 OUTPUT @Hp4396;"OUTPCERR?"
60 ENTER @Hp4396;Zr,Fr,Za,Fa,R1,R2,R3
70 PRINT "Resonant: ";Zr;" [ohm] ,";Fr;" [Hz] "
80 PRINT "Anti-Resonant: ";Za;" [ohm] ,";Fa;" [Hz] "
90 PRINT "Ripple L: ";R1;" [dB] "
100 PRINT "Ripple M: ";R2;" [dB] "
110 PRINT "Ripple R: ";R3;" [dB] "
120 END

```

For Instrument BASIC

```

10 ASSIGN @Hp4396 TO 800
20 OUTPUT @Hp4396;"FMT LOGM"
30 OUTPUT @Hp4396;"CENT 60.02MHz; SPAN 20kHz"
40 EXECUTE "SING"
50 EXECUTE "ANAOCH1"
60 EXECUTE "ANARFULL"
70 EXECUTE "ANAODATA"
80 EXECUTE "OUTPCERR?"
90 PRINT "Resonant: ";READIO(8,0);" [ohm] ,";READIO(8,1);" [Hz] "
100 PRINT "Anti-Resonant: ";READIO(8,2);" [ohm] ,";READIO(8,3);" [Hz] "
110 PRINT "Ripple L: ";READIO(8,4);" [dB] "
120 PRINT "Ripple M: ";READIO(8,5);" [dB] "
130 PRINT "Ripple R: ";READIO(8,6);" [dB] "
140 END

```

Equivalent circuit analysis commands

The following commands are for the equivalent circuit analysis. They are easy to use for specific device analysis because they can output many parameters using only a single command.

- EQUCPARA?
 - EQU
- EQUCPARS?
- EQUCO?
- EQUCPARS4?

EQUCPARA?

Returns the six-device equivalent circuit parameters of the crystal resonator. (Query only)

Syntax EQUCPARA?

Query $C_0, C_1, L_1, R_1, G_0, R_0$ (Total 6)

Response Where,

Register	Parameter	Description
0	C_0	Parallel capacitance
1	C_1	Motional capacitance
2	L_1	Motional inductance
3	R_1	Motional resistance
4	G_0	Electrode conductance
5	R_0	Electrode resistance

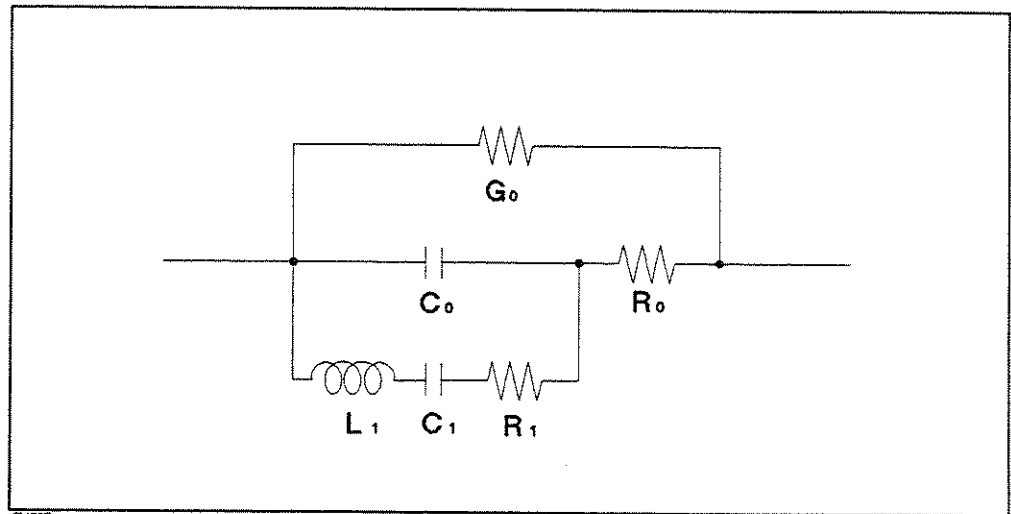

Figure I-17. Six-Device Equivalent Circuit of Crystal Resonator

Semantics ■ EQUCPARA? executes the following actions:

1. Obtains the admittance characteristic circle diagram.
2. Obtains the maximum conductance. (G_{max})
3. Obtains frequencies f_1 and f_2 ($f_1 < f_2$) of the two points where the conductance is half the maximum conductance (G_{max}).
4. Calculates f_s by $f_s = \sqrt{f_1 \times f_2}$.
5. Obtains susceptance B_{f_s} at f_s .
6. Calculates ω_s by $\omega_s = 2 \times \pi \times f_s$.
7. Assumes that the frequency at which the phase becomes 0° near the parallel resonance frequency is f_a , and obtains its conductance G_a .
8. Calculates ω_a by $\omega_a = 2 \times \pi \times f_a$.

9. Assumes that the frequency at which the phase becomes 0° * near the series resonance frequency is f_r .
10. Calculates the constants using the above values and the following equations:

$$\begin{aligned}
 Q_s &= \frac{f_s}{f_2 - f_1} & C_o' &= \frac{B_1 + B_2}{2\omega_s} \\
 L_1 &= \frac{Q_s}{\omega_s G_{max}} & R_1 &= \frac{C_o'}{C_o G_{max}} \\
 C_1 &= \frac{G_{max}}{\omega_s Q_s} & R_o &= \frac{1}{G_{max}} - R_1 \\
 C_o &= \frac{B_{fs}}{\omega_s} & G_o &= G_a - \frac{R_1 \omega_a^2 C_o^2}{1 + R_o R_1 \omega_a^2 C_o^2}
 \end{aligned}$$

* "EQUCPARA?" interpolates the 0° phase points even if it does not exist in measured data.

- If the number of points between the maximum peak point (f_{Bmax}) and the minimum peak point (f_{Bmin}) of the conductance is less than 10 points, EQUCPARA? approximates an admittance circle. The circle approximation can be performed if there are 3 points for analysis. You can specify how many points are used for circle approximation using the EQU command to reduce the analysis time.
- If EQUCPARA? fails the circle approximation, 0 will be return for all parameters.
- If there are only 2 points for analysis, EQUCPARA? returns four-device equivalent circuit parameters. In this case, EQUCPARA? returns 0 for G_o and R_o .
- If there is only 1 point for analysis, EQUCPARA? returns 0 for all parameters.

EQU
value

Specifies how many points are used for an approximation of a circle with the EQUCPARA? and EQUCPARS? commands. EQUCPARA? (or EQUCPARS?) thins the measured points out for the specified points, then makes a circle approximation. When the EQU parameter is set greater than the number of points, EQUCPARA? uses all the points for the circle approximation. Default value is 8.
value 2 to 801

Note

- You must select the following conditions or Polar format to use this command:
 - Dual Channel & Coupled Channel: ON
 - Impedance Conversion: ON
 - Analysis channel: LOG MAG format
 - Non-analysis channel: Phase format

If another format is selected, 0 will be returned for query response.

Examples

For External Controller

```

10 ASSIGN @Hp4396 TO 717
20 OUTPUT @Hp4396;"FMT POLA; CONV YTRA; CENT 60.06MHz; SPAN 20kHz"
30 CALL Sweep(1) ! Goes to sub routine. (See OUTPFILT?)
40 OUTPUT @Hp4396;"ANAOCH1;ANARFULL;ANAODATA"
50 OUTPUT @Hp4396;"EQUCPARA?"
60 ENTER @Hp4396;CO,C1,L1,R1,GO,RO
70 PRINT "CO: ";CO;" C1: ";C1
80 PRINT "L1: ";L1;" R1: ";R1
90 PRINT "GO: ";GO;" RO: ";RO
100 END

```

For Instrument BASIC

```
10 ASSIGN @Hp4396 TO 800
20 OUTPUT @Hp4396;"FMT POLA; CONV YTRA"
30 OUTPUT @Hp4396;"CENT 60.06MHZ; SPAN 20kHz"
40 EXECUTE "SING"
50 EXECUTE "ANAOCH1"
60 EXECUTE "ANARFULL"
70 EXECUTE "ANAODATA"
80 WRITEIO 8,0;4
90 EXECUTE "EQUM"
100 EXECUTE "EQUCPARA?"
110 PRINT "CO:";READIO(8,0);" C1:";READIO(8,1)
120 PRINT "L1:";READIO(8,2);" R1:";READIO(8,3)
130 PRINT "GO:";READIO(8,4);" RO:";READIO(8,5)
140 END
```

EQUCPARS?

Outputs the six-device equivalent circuit parameters of the crystal resonator. (Query only)

Syntax EQUCPARS?

Query $C_0, C_1, L_1, R_1, f_s, f_a, f_r, f_1^*, f_2^*, G_0, R_0$ (Total 11)

Response * $f_1 < f_2$

For information about each parameter, see "EQUCPARA?".

Note ■ You must select the following conditions or Polar format to use this command:

- Dual Channel & Coupled Channel: ON
- Impedance Conversion: ON
- Analysis channel: LOG MAG format
- Non-analysis channel: Phase format

If another format is selected, 0 will be returned for query response.

EQUCO? *value*

Returns the parallel capacitance (C_0) of the equivalent circuit of the resonator at the specified frequency. (Query only)

Syntax EQUCO? *value*

Where,

Register	Parameter	Description
0	<i>value</i>	Frequency for C_0

Query C_0

Response

Where,

Register	Parameter	Description
0	C_0	Parallel capacitance

Semantics ■ C_0 is calculated using the following equation:

$$C_0 = \frac{B_s}{\omega_s}$$

Where,

B_s Imaginary part of the point on f_s .

$\omega_s = 2\pi f_s$

f_s Frequency that is specified by the command parameter.

■ If the impedance conversion is selected, C_0 is calculated using the following equation:

$$C_0 = \frac{-1}{B_s \times \omega_s}$$

Note ■ You must select the following conditions or Polar format to use this command:

- Dual Channel & Coupled Channel: ON
- Impedance Conversion: ON
- Analysis channel: LOG MAG format
- Non-analysis channel: Phase format

If another format is selected, 0 will be returned for query response.

- If the specified frequency is out of analysis range, 0 will be returned.
- If B_s is 0 when the impedance conversion is selected, EQUCO? returns 0.

Examples For External Controller

```
10 ASSIGN @Hp4396 TO 717
20 OUTPUT @Hp4396;"DUAC ON; COUC ON"
30 OUTPUT @Hp4396;"CHAN2; FMT PHAS"
40 OUTPUT @Hp4396;"CHAN1; FMT LOGM; CONV ZTRA"
50 OUTPUT @Hp4396;"CENT 60.06MHz; SPAN 20kHz"
60 CALL Sweep(2) ! Goes to sob routine. (See OUTPFILT?)
70 OUTPUT @Hp4396;"ANAOCH1;ANARFULL;ANAOData"
80 OUTPUT @Hp4396;"EQUCO? 60.06MHz"
```

```
90 ENTER @Hp4396;CO
100 PRINT "CO: ";CO
110 END
```

For Instrument BASIC

```
10 ASSIGN @Hp4396 TO 800
20 OUTPUT @Hp4396;"FMT POLA"
30 OUTPUT @Hp4396;"CENT 60.06MHZ; SPAN 20kHz"
40 EXECUTE "SING"
50 EXECUTE "ANAOCH1"
60 EXECUTE "ANARFULL"
70 EXECUTE "ANAODATA"
80 WRITEIO 8,0;6.006E+7
90 EXECUTE "EQUO?"
100 PRINT "CO: ";READIO(8,0)
110 END
```

EQUCPARS4?

Returns the 4-device equivalent circuit parameters of the crystal resonator. (Query only)

Syntax EQUCPARS4?

Query Response $C_0, C_1, L_1, R_1, f_s, f_a, f_r, f_1, f_2$ (Total9)

Where,

Register	Parameter	Description
0	C_0	Parallel capacitance
1	C_1	Motional capacitance
2	L_1	Motional inductance
3	R_1	Motional resistance
4	f_s	Motional (parallel) resonant frequency
5	f_a	Anti-resonant frequency
6	f_r	Resonant frequency
7	f_1	Frequency at the point where the half of maximum conductance.
8	f_2	Frequency at the point where the half of maximum conductance. ($f_1 < f_2$)

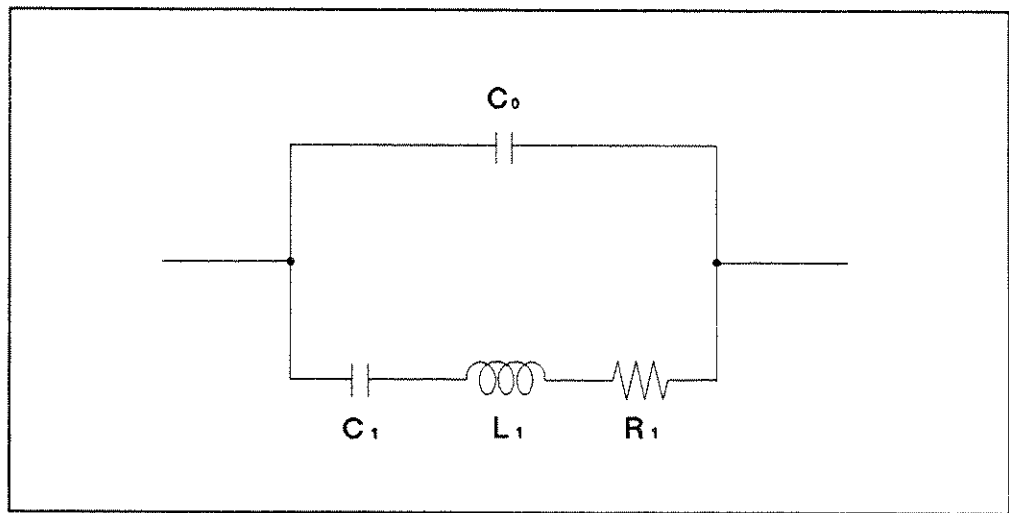

Figure I-18. Four-Device Equivalent Circuit of Crystal Resonator

- Semantics**
- You need to select the polar format (FMT POLA) and turn the admittance conversion on to use this command.
 - EQUCPARS4? executes the following actions:
 1. Obtains the admittance characteristic circle diagram. (See Figure I-19.)
 2. Obtains the susceptance (B_{fs}) and its frequency (f_s) at the maximum conductance (G_{max}) point.
 3. Obtains frequencies f_1 and f_2 ($f_1 < f_2$) of the two points where the conductance is half the maximum conductance (G_{max}).

4. Assumes that the frequency at which the phase becomes 0° near the parallel resonance frequency is f_a .
5. Assumes that the frequency at which the phase becomes 0° near the series resonance frequency is f_r .
6. Calculates the constants using the above values and the following equations:

$$C_0 = \frac{f_r^2}{f_a^2 - f_r^2} \times C_1$$

$$C_1 = \frac{1}{QR_1 2\pi f_s}$$

$$L_1 = \frac{QR_1}{2\pi f_s}$$

$$Q = \left| \frac{f_s}{f_2 - f_1} \right|$$

$$R_1 = \frac{1}{G_{max}}$$

If there are no f_r and f_a points on the admittance chart, C_0 is calculated using the following equation:

$$C_0 = \frac{B_{f_s}}{2\pi f_s}$$

Where, B_{f_s} is the susceptance at the G_{max} point.

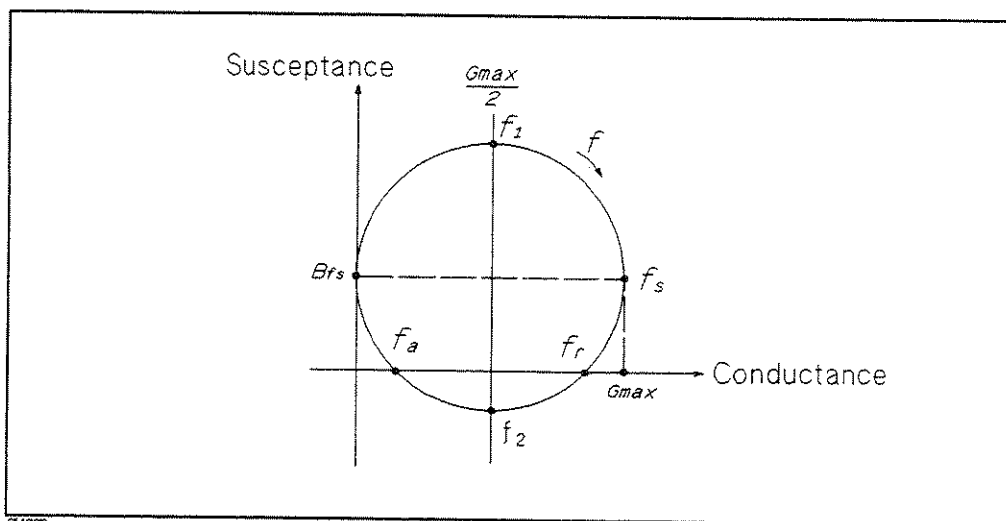

Figure I-19. Admittance Characteristic Circle Diagram

Note * This command is only available when Polar format and the admittance conversion is on. If these are not selected, 0 will be returned.

Examples For External Controller

```

10 ASSIGN @Hp4396 TO 717
20 OUTPUT @Hp4396;"FMT POLA; CONV YTRA; CENT 60.06MHz; SPAN 20kHz"
30 CALL Sweep(1) ! Goes to sub routine. (See OUTPFILT?)
40 OUTPUT @Hp4396;"ANAOCH1;ANARFULL;ANAODATA"
50 OUTPUT @Hp4396;"EQUCPARS4?"
60 ENTER @Hp4396;C0,C1,L1,R1
70 PRINT "C0:";C0;" C1:";C1
80 PRINT "L1:";L1;" R1:";R1
90 END

```

For Instrument BASIC

```
10 ASSIGN @Hp4396 TO 800
20 OUTPUT @Hp4396;"FMT POLA; CONV YTRA"
30 OUTPUT @Hp4396;"CENT 60.06MHZ; SPAN 20kHz"
40 EXECUTE "ANAOCH1"
50 EXECUTE "ANARFULL"
60 EXECUTE "ANAOATA"
70 EXECUTE "EQUCPARS4?"
80 PRINT "CO=";READIO(8,0);",C1=";READIO(8,1)
90 PRINT "L1=";READIO(8,2);",R1=";READIO(8,3)
100 END
```

Error Messages

This section lists the error messages that are displayed on the analyzer display or transmitted by the instrument over HP-IB. Each error message is accompanied by an explanation, and suggestions are provided to help in solving the problem. Where applicable, references are provided to the related chapter of the appropriate manual. The messages are listed in numerical order.

In the explanation of many error commands, section numbers of the IEEE standard 488.2 are included. Refer to them for further information about an error with these IEEE section numbers.

+0 No error

The error queue is empty. Every error in the queue has been read (OUTPERRO? query) or the queue was cleared by power-on or the *CLS command.

1 CAN'T SET RBW AUTO IN ZERO SPAN

The RBW AUTO mode cannot be selected in the zero span. The RBW must be specified manually in the zero span. See Chapter 2 of the *Function Reference* (spectrum analyzer mode only).

10 ADDITIONAL STANDARDS NEEDED

Error correction for the selected calibration class cannot be computed until all the necessary standards have been measured.

11 CALIBRATION REQUIRED

No valid calibration coefficients were found when you attempted to turn calibration ON. See *Task Reference* for information on how to perform calibration.

12 NO CALIBRATION CURRENTLY IN PROGRESS

The **RESUME CAL SEQUENCE** softkey is not valid unless a calibration is in progress. Start a new calibration. See "**Cal**" key in the *Function Reference*.

13 CALIBRATION ABORTED

The calibration in progress was terminated due to a change of the active channel or stimulus parameters.

14 NOT VALID FOR PRESENT TEST SET

The calibration requested is inconsistent with the test set present. This message occurs in the following situations:

- A full 2-port calibration is requested with a test set other than an S-parameter test set.
- A one-path 2-port calibration is requested with an S-parameter test set (this procedure is typically used with a transmission/reflection test set).

15 EXCEEDED 7 STANDARDS PER CLASS

A maximum of seven standards can be defined for any class. See "Modifying Calibration Kits" in the *Function Reference*.

16 CURRENT PARAMETER NOT IN CAL SET

HP-IB only. Correction is not valid for the selected measurement parameter.

17 BACKUP DATA LOST

Data checksum error on the battery backup memory has occurred. The battery is recharged for approximately 10 minutes after power was turned ON.

18 NOT ALLOWED IN LIST SWEEP

The level cal cannot be executed in the list sweep. The sweep type must be the linear frequency (spectrum analyzer mode only). See Chapter 5 of the *Function Reference*.

19 UNEXPECTED DATA DETECTED: CAL ABORTED

The signal measured for the level cal is not adequate for the calibration signal. (spectrum analyzer mode only.) See Chapter 5 of the *Function Reference*.

26 PRINTER: not on, not connect, wrong address

The printer does not respond to control. Verify power to the plotter, and check the HP-IB connection between the analyzer and the printer. Ensure that the printer address recognized by the analyzer matches the HP-IB address set on the printer itself.

27 PLOTTER: not on, not connect, wrong address

The plotter does not respond to control. Verify power to the plotter, and check the HP-IB connection between the analyzer and the plotter. Ensure that the plotter address recognized by the analyzer matches the HP-IB address set on the plotter itself.

29 PLOTTER NOT READY - PINCH WHEELS UP

If you attempt to plot when the plotter's pinch wheels are up, this message is displayed.

34 NO VALID MEMORY TRACE

If a memory trace is to be displayed or otherwise used, a data trace must first be stored to memory.

44 OVERLOAD ON INPUT B

45 OVERLOAD ON INPUT A

46 OVERLOAD ON INPUT R

47 OVERLOAD ON INPUT S

The power level at one of the four receiver inputs exceeds a certain level greater than the maximum input level.

48 PHASE LOCK LOOP UNLOCKED

Sever error. Contact your nearest Hewlett-Packard office.

49 POWER FAILED ON *nnn*

Sever error. Contact your nearest Hewlett-Packard office. One or more power is failed. *nnn* is one of -5 V, -15 V, +5 V, +15 V, +65 V, and PostRegHot. It shows that which power line is failed. When this error occurs, the system halts so a controller cannot read this error by HP-IB.

50 CONT SWITCHING MAY DAMAGE MECH SWITCH

RF output power switch or input attenuator switch at input S is switching sweep by sweep, because RF power level or the input attenuator setting is different between two channels and the dual channel is turn on. To avoid premature wearing out of the output power switch and input attenuator switch, change trigger type to HOLD, SINGLE, or NUMBER of GROUP to hold sweep after measurement required. Or turn off the dual channel, or set the power level and the input attenuator of both channels to the same setting.

51 MEASUREMENT INVALID AT $f < = 1\text{MHz}$, $\text{IFBW} > = 10\text{kHz}$

This message will displayed when whole frequency measured is less than or equal to 1 MHz and IFBW is set to 10 kHz or 40 kHz because the network measurement performance is not warranted at frequency ≤ 1 MHz with 10 kHz or 40 kHz IFBW.

54 TOO MUCH DATA

Either there is too much binary data to send to the analyzer when the data transfer format is FORM 2, FORM 3 or FORM 5, or the amount of data is greater than the number of points.

55 NOT ENOUGH DATA

The amount of data sent to the analyzer is less than that expected (*HP-IB only*).

56 OPTION NOT INSTALLED

This error occurs when an HP-IB command which is optional command is sent and the analyzer is not installed the option (*HP-IB only*). Please confirm options installed to the analyzer using *OPT? command (see "*OPT?" in Chapter 2.)

64 TOO MANY SEGMENTS

The maximum number of segments for the limit line table is 18. See Chapter 8 of the *Task Reference*.

74 CURRENT EDITING SEGMENT SCRATCHED

The current editing segment for the list table and the limit line is scratched when the following cases occur (*HP-IB only*):

- When EDITLIST (edit list table) command is received while editing a segment for the list table.
- When EDITLIML (edit limit line) command is received while editing a segment for the limit line.

Send LIMSDON (limit segment done) or SDON (segment done) to terminate editing segment.

75 COMMAND IGNORED - SEGMENT NOT DONE YET

The HP-IB command the analyzer received is ignored, because the segment is editing (*HP-IB only*). Send LIMSDON (limit segment done) or SDON (segment done) to terminate editing segment. (See "LIMSDON" in Chapter 2 and "SDON" in Chapter 2.)

76 SEGMENT START/STOP OVERLAPPED

Segments are not allowed to be overlapped. Reenter appropriate value for start or stop value of segments to avoid that segment is not overlapped.

77 TOO MANY SEGMENTS OR POINTS

Frequency list mode is limited to 31 segments or 801 points.

78 TOO SMALL POINTS OR TOO LARGE STOP

STOP+SPAN/(NOP-1) is out of sweep range. Increase NOP or change STOP value to lower frequency to avoid this error.

82 CAN'T CHANGE- ANOTHER CONTROLLER ON BUS

The analyzer cannot assume the mode of system controller until the active controller is removed from the bus or relinquishes the bus. See Chapter 7 of the *HP-IB Programming Guide*.

83 FORMAT NOT VALID FOR MEASUREMENT

The conversion function except the 1/S and the multiple phase modes is not valid for the Smith, admittance, and SWR formats.

84 ANALYZER TYPE MISMATCH

The analyzer receives a command that is not available for the current analyzer type. Please confirm HP-IB command or change analyzer type before sending the command.

93 NO DATA TRACE

The **MARKER ON [DATA]** is selected when the data trace is not displayed.

94 NO MEMORY TRACE

The **MARKER ON [MEMORY]** is selected when the memory trace is not displayed.

95 NO MARKER DELTA - SPAN NOT SET

The **MKRA→SPAN** softkey requires that delta marker mode be turned on.

96 NO MARKER DELTA - RANGE NOT SET

The **MKRA→SEARCH RNG** softkey requires that delta marker is turned on.

98 NO ACTIVE MARKER

The **marker→** command cannot be execute when no marker is displayed on the screen. Turn on the marker before executing the **marker→** commands.

99 CAN'T CHANGE WHILE DUAL CHAN OFF

The Cross channel cannot be turned on when dual channel is off. Turn on the dual channel before the cross channel is turned on.

110 SAVE ERROR

A serious error, for example physically damaged disk surface, is detected on saving a file.

111 RECALL ERROR: INSTR STATE PRESET

A serious error, for example corrupted data, is detected on recalling a file, and this forced the analyzer to be PRESET.

112 INVALID FILE NAME

HP-IB only. The file name for the RECALL, PURGE, or RE-SAVE function must have a "_D" or "_S" extension for LIF format.

113 NO STATE/DATA FILES ON DISK

There are no files on the flexible disk with extensions, "_D" or "_S" for LIF format, or "STA" or ".DTA" for DOS format.

114 CAN'T SAVE GRAPHICS WHEN COPY IN PROGRESS

If you attempt to save graphics when a print or plot is in progress, this error message is displayed.

115 LIF-DOS COPY NOT ALLOWED

If you try to copy a file between the RAM disk and the flexible disk when the format of the RAM disk is different from the format of the flexible disk, this message is displayed.

116 NO STATE/DATA FILES ON MEMORY

There are no files on the RAM disk memory with extensions, "_D" or "_S" for LIF format, or "STA" or ".DTA" for DOS format.

119 NO DATA TRACE DISPLAYED

The **SCALE FOR [DATA]** is selected when the data trace is not displayed.

120 NO MEMORY TRACE DISPLAYED

The **SCALE FOR [MEMORY]** is selected when the memory trace is not displayed.

124 LIST TABLE EMPTY OR INSUFFICIENT TABLE

The frequency list is empty. To implement the list frequency mode, add segments to the list table.

125 CAN'T SET SLOPE ON IN POWER SWEEP

The slope function can be turned on in frequency sweep.

126 CAN'T CHANGE NUMBER OF POINTS

The number of points of the spectrum analyzer mode cannot be to change manually, except in zero span.

127 CAN'T SET SWEEP TIME AUTO IN ZERO SPAN

The automatic sweep time cannot be in zero span of the spectrum analyzer mode. (The network analyzer mode allows that the automatic sweep time is turned on.)

128 Repet Smpling : SPAN = 0 ONLY

The repetitive sampling is turn on when span must be zero, the sweep type must be linear frequency, and the trigger source must be EXT or VIDEO only. Confirm the analyzer setting and set appropriate setting for the repetitive sampling mode.

129 Repet Smpling : LIN FREQ ONLY

The repetitive sampling is turn on when span must be zero, the sweep type must be linear frequency, and the trigger source must be EXT or VIDEO only. Confirm the analyzer setting and set appropriate setting for the repetitive sampling mode.

130 Repet Smpling : TRIG = EXT or VIDEO ONLY

The repetitive sampling is turn on when span must be zero, the sweep type must be linear frequency, and the trigger source must be EXT or VIDEO only. Confirm the analyzer setting and set appropriate setting for the repetitive sampling mode.

131 FREQUENCY SWEEP ONLY

The sweep type must be frequency sweep when the center step size is set.

132 COUPLED CHAN - BETWEEN NA & NA ONLY

The analyzer types of both channels must be the network analyzer mode when the coupled channel is turned on.

133 CAN'T CHANGE ON LIST SWEEP

When list sweep is selected, the following parameters are not allowed to be changed:

- CENTER, SPAN, START, STOP
- NOP
- IFBW or RBW
- POWER

Modify the list table to change these parameters in the list sweep.

134 CAN'T COUPLE IN CURRENT INPUTS

When one channel measures a ratio measurement, and the other one measures an absolute measurement (for example: A/R and B), **COUPLED CH** can not be turned on.

141 INSUFFICIENT MEMORY

If a lot of tasks is executed at same time, memory might be insufficient for a while. (For example, running HP Instrument BASIC program, printing a screen, and sending or receiving data array by HP-IB are required at same time.) Please wait until finishing some tasks then execute the next task.

146 ON POINT NOT ALLOWD FOR THE CURRENT TRIG

The trigger event mode cannot be changed to the ON POINT mode because the current trigger source setting does not allow the ON POINT mode. The trigger event ON POINT mode is available for only MANUAL, EXTERNAL, and BUS trigger sources of the network analyzer mode.

154 INVALID DATE

The date entered to set the real time clock is invalid. Reenter correct date.

193 POWER ON TEST FAILED

An internal test fails in the power on sequence (the power on self-test fails). Contact your nearest Hewlett-Packard office or see the *Service Manual* for troubleshooting.

194 EEPROM WRITE ERROR

Data cannot be stored properly into the EEPROM on the A1 CPU, when performing the display background adjustment or updating correction constants in the EEPROM using the adjustment program. See the *Service Manual* for troubleshooting.

195 ALL INT TEST FAILED

An "internal test 0: ALL INT" fails. See the *Service Manual* for troubleshooting.

196 FLASH MEMORY CHECK SUM ERROR

The data (firmware) stored in the A1 flash memory are invalid. This message is displayed in the bootloader menu. See the *Service Manual* for troubleshooting.

197 BACKUP SRAM CHECK SUM ERROR

An "internal test 1: A1 CPU" fails. The data (HP-IB Address and so on) stored in the A1 CPUs BACKUP SRAM are invalid. Replace the A1 CPU with a new one. See the *Service Manual* for troubleshooting.

198 EEPROM CHECK SUM ERROR

An "internal test 1: A1 CPU" fails. The data (Correction Constants and so on) stored in the A1 CPU's EEPROM are invalid. See the *Service Manual* for troubleshooting.

199 DSP CHIP TEST FAILED

An "internal test 1: A1 CPU" fails. The A1 CPU's DSP (Digital Signal Processor) does not work properly. Replace the A1 CPU with a new one. See the *Service Manual* for troubleshooting.

200 F-BUS TIMER CHIP TEST FAILED

An "internal test 1: A1 CPU" fails. The A1 CPU's F-BUS (Frequency Bus) timer does not work properly. Replace the A1 CPU with a new one. See the *Service Manual* for troubleshooting.

201 RTC CHIP TEST FAILED

An "internal test 1: A1 CPU" fails. The A1 CPU's RTC (Real Time Clock) does not work properly. Replace the A1 CPU with a new one. See the *Service Manual* for troubleshooting.

202 KEY CHIP TEST FAILED

An "internal test 1: A1 CPU" fails. The A1 CPU's front keyboard control chip does not work properly. Replace the A1 CPU with a new one. See the *Service Manual* for troubleshooting.

203 FDC CHIP TEST FAILED

An "internal test 1: A1 CPU" fails. The A1 CPU's FDC (Flexible Disk drive control) chip does not work properly. Replace the A1 CPU with a new one. See the *Service Manual* for troubleshooting.

204 HP-IB CHIP TEST FAILED

An "internal test 1: A1 CPU" fails. The A1 CPU's HP-IB chip does not work properly. Replace the A1 CPU with a new one. See the *Service Manual* for troubleshooting.

205 HP-HIL CHIP TEST FAILED

An "internal test 1: A1 CPU" fails. The A1 CPU's HP-HIL control chip does not work properly. Replace the A1 CPU with a new one. See the *Service Manual* for troubleshooting.

206 CPU INTERNAL SRAM R/W ERROR

An "internal test 2: A1 VOLATILE MEMORY" fails. The A1 CPU's internal SRAM does not work properly. Replace the A1 CPU with a new one. See the *Service Manual* for troubleshooting.

207 CPU BACKUP SRAM R/W ERROR

An "internal test 2: A1 VOLATILE MEMORY" fails. The A1 CPU's BACKUP SRAM does not work properly. Replace the A1 CPU with a new one. See the *Service Manual* for troubleshooting.

208 DSP SRAM R/W ERROR

An "internal test 2: A1 VOLATILE MEMORY" fails. The DSP's SRAM on the A1 CPU does not work properly. Replace the A1 CPU with a new one. See the *Service Manual* for troubleshooting.

209 DUAL PORT SRAM R/W ERROR

An "internal test 2: A1 VOLATILE MEMORY" fails. The DSP's dual port SRAM on the A1 CPU does not work properly. Replace the A1 CPU with a new one. See the *Service Manual* for troubleshooting.

210 POST REGULATOR OUTPUT VOLTAGE OUT OF SPEC

An "internal test 4: A2 POST REGULATOR" fails. A power supply voltage of the A2 post-regulator is out of its limits. See the *Service Manual* for troubleshooting.

211 GND LEVEL OUT OF SPEC

An "internal test 4: A2 POST REGULATOR" fails. The voltage of the GND (Ground) at the DC bus node 26 is out of its limits. See the *Service Manual* for troubleshooting.

212 FAN POWER OUT OF SPEC

An "internal test 4: A2 POST REGULATOR" fails. The voltage of the fan power supply at the DC bus node 11 is out of its limits. See the *Service Manual* for troubleshooting.

213 FAILURE FOUND FROM A/D MUX TO A/D CONVERTER

An "internal test 5: A6 A/D CONVERTER" fails. A trouble is found on the signal path from the A/D multiplexer to A/D converter on the A6 receiver IF. See the *Service Manual* for troubleshooting.

214 REF OSC TEST FAILED

An "internal test 6: A5 REFERENCE OSC" fails. The reference oscillator on the A5 synthesizer does not work properly. See the *Service Manual* for troubleshooting.

215 FRACTIONAL N OSC TEST FAILED

An "internal test 7: A5 FRACTIONAL N OSC" fails. The fractional N oscillator on the A5 synthesizer does not work properly. See the *Service Manual* for troubleshooting.

216 STEP OSC TEST FAILED

An "internal test 8: A5 STEP OSC" fails. The step oscillator on the A5 synthesizer does not work properly. See the *Service Manual* for troubleshooting.

217 1st LO OSC TEST FAILED

An "internal test 9: A4A1 1ST LO OSC" fails. The 1st LO OSC (first local oscillator) on the A4A1 1st LO does not work properly. See the *Service Manual* for troubleshooting.

218 2nd LO OSC TEST FAILED

An "internal test 10: A3A2 2ND LO" fails. The 2nd LO OSC (second local oscillator) on the A3A2 2nd LO does not work properly. See the *Service Manual* for troubleshooting.

219 3rd LO OSC TEST FAILED

An "internal test 12: A6 3RD LO OSC" fails. The 3rd LO OSC (third local oscillator) on the A6 receiver IF does not work properly. See the *Service Manual* for troubleshooting.

220 SOURCE OSC TEST FAILURE

An "internal test 13: A3A1 SOURCE OSC" fails. The source oscillator on the A3A1 ALC does not work properly. See the *Service Manual* for troubleshooting.

221 DC OFFSET TOO BIG ON 0 DEG PATH

An "internal test 14: A6 3rd IF DC OFFSET" fails. The DC offset on 0° path of the A6 receiver IF is larger than its limit. See the *Service Manual* for troubleshooting.

222 DC OFFSET TOO BIG ON 90 DEG PATH

An "internal test 14: A6 3rd IF DC OFFSET" fails. The DC offset on 90° path of the A6 receiver IF is larger than its limit. See the *Service Manual* for troubleshooting.

223 SAMPLE FREQUENCY OUT OF SPEC

An "internal test 15: A6 SEQUENCER" fails. The sampling frequency of the sample/hold circuit on the A6 receiver IF is out of its limits. See the *Service Manual* for troubleshooting.

224 ALC TEST FAILED

An "internal test 16: A3A1 ALC" fails. The ALC (Auto Level Control) circuit on the A3A1 ALC does not work properly. See the *Service Manual* for troubleshooting.

225 A3 DIVIDER OUTPUT FREQUENCY OUT OF SPEC

An "internal test 11: A3A1 DIVIDER" fails. The output frequency of the divider circuit on the A3A1 ALC is out of its limits. See the *Service Manual* for troubleshooting.

226 FLOPPY DISK DRIVE FAILURE FOUND

An "external test 18: DSK DR FAULT ISOL'N" fails. The A53 built-in FDD (flexible disk drive) does not work properly. Replace the A53 FDD with a new one. See the *Service Manual* for troubleshooting.

227 POWER SWEEP LINEARITY OUT OF SPEC

An "external test 19: POWER SWEEP LINEARITY" fails. See the *Service Manual* for troubleshooting.

228 OUTPUT ATTENUATOR ACCURACY OUT OF SPEC

An "external test 20: OUTPUT ATTENUATOR" fails. See the *Service Manual* for troubleshooting.

229 INPUT ATTENUATOR ACCURACY OUT OF SPEC

An "external test 21: INPUT ATTENUATOR" fails. See the *Service Manual* for troubleshooting.

230 RF OUT TO S-INPUT FLATNESS TEST FAILED

An "external test 22: RF TO S LVL & FLTNESS" fails. See the *Service Manual* for troubleshooting.

231 S-INPUT TO A-INPUT CROSSTALK TEST FAILED

An "external test 23: S TO A CROSSTALK" fails. See the *Service Manual* for troubleshooting.

232 S-INPUT LEVEL COMPRESSION TEST FAILED

An "external test 24: S INPUT COMPRESSION" fails. See the *Service Manual* for troubleshooting.

233 S-INPUT RESIDUAL RESPONSE OUT OF SPEC

An "external test 25: S INPUT RESIDUALS" fails. See the *Service Manual* for troubleshooting.

234 1st LO LEAKAGE TEST FAILED

An "external test 25: S INPUT RESIDUALS" fails. See the *Service Manual* for troubleshooting.

235 S-INPUT NOISE LEVEL OUT OF SPEC

An "external test 26: S INPUT NOISE LEVEL" fails. See the *Service Manual* for troubleshooting.

236 FRACTION SPURIOUS OUT OF SPEC

An "external test 27: FRACTION SPURIOUS" fails. See the *Service Manual* for troubleshooting.

237 RF OUT TO R-INPUT FLATNESS TEST FAILED

An "external test 28: RF TO A LVL & FLTNESS" fails. See the *Service Manual* for troubleshooting.

238 R-INPUT TO A-INPUT CROSSTALK OUT OF SPEC

An "external test 29: NA CROSSTALK & NOISE" fails. See the *Service Manual* for troubleshooting.

239 R-INPUT TO B-INPUT CROSSTALK OUT OF SPEC

An "external test 29: NA CROSSTALK & NOISE" fails. See the *Service Manual* for troubleshooting.

240 R-INPUT NOISE LEVEL OUT OF SPEC

An "external test 29: NA CROSSTALK & NOISE" fails. See the *Service Manual* for troubleshooting.

241 A-INPUT NOISE LEVEL OUT OF SPEC

An "external test 29: NA CROSSTALK & NOISE" fails. See the *Service Manual* for troubleshooting.

242 B-INPUT NOISE LEVEL OUT OF SPEC

An "external test 29: NA CROSSTALK & NOISE" fails. See the *Service Manual* for troubleshooting.

243 R-INPUT LEVEL COMPRESSION TEST FAILED

An "external test 30: R INPUT COMPRESSION" fails. See the *Service Manual* for troubleshooting.

244 RANGING ACCURACY TEST FAILED

An "external test 31: RANGING" fails. See the *Service Manual* for troubleshooting.

245 A/R RATIO ACCURACY OUT OF SPEC

An "external test 32: A/R RATIO ACCURACY" fails. See the *Service Manual* for troubleshooting.

246 A/R RATIO RAW RESPONSE TEST FAILED"

An "external test 32: A/R RATIO ACCURACY" fails. See the *Service Manual* for troubleshooting.

247 A-INPUT LEVEL COMPRESSION TEST FAILED

An "external test 33: A INPUT COMPRESSION" fails. See the *Service Manual* for troubleshooting.

248 B/R RATIO ACCURACY OUT OF SPEC

An "external test 34: B/R RATIO ACCURACY" fails. See the *Service Manual* for troubleshooting.

249 B/R RAW RESPONSE TEST FAILED

An "external test 34: B/R RATIO ACCURACY" fails. See the *Service Manual* for troubleshooting.

250 B-INPUT LEVEL COMPRESSION TEST FAILED

An "external test 35: B INPUT COMPRESSION" fails. See the *Service Manual* for troubleshooting.

251 SA RES FILTER 3 DB BW OUT OF SPEC

An "external test 36: RESOLUTION BANDWIDTH" fails. See the *Service Manual* for troubleshooting.

252 SA RES FILTER SHAPE FACTOR OUT OF SPEC

An "external test 36: RESOLUTION BANDWIDTH" fails. See the *Service Manual* for troubleshooting.

253 SA RES FILTER TRACK NOISE TEST FAILED

An "external test 36: RESOLUTION BANDWIDTH" fails. See the *Service Manual* for troubleshooting.

254 SA RES FILTER SWITCHING UNC. OUT OF SPEC

An "external test 36: RESOLUTION BANDWIDTH" fails. See the *Service Manual* for troubleshooting.

255 IF GAIN SWITCHING UNC. OUT OF SPEC

An "external test 37: IF GAIN" fails. See the *Service Manual* for troubleshooting.

256 SIDE BAND LEVEL OUT OF SPEC

An "external test 38: PHASE NOISE" fails. See the *Service Manual* for troubleshooting.

257 SA NON-HARMONIC SPURIOUS OUT OF SPEC

An "external test 39: SPURIOUS" fails. See the *Service Manual* for troubleshooting.

258 X-TAL FILTER RESPONSE OUT OF SPEC

An "external test 40: X'TAL FILTER RESPONSE" fails. See the *Service Manual* for troubleshooting.

259 **X-TAL FILTER RAW RESPONSE TEST FAILED**

An "external test 40: X'TAL FILTER RESPONSE" fails. See the *Service Manual* for troubleshooting.

260 **ALL EXT TEST FAILED**

"External tests 63 to 67" fails. See the *Service Manual* for troubleshooting.

-100 **Command error**

This is a generic syntax error that the analyzer cannot detect more specific errors. This code indicates only that a command error, as defined in IEEE 488.2, 11.5.1.1.4, has occurred.

-101 **Invalid character**

A syntax element contains a character that is invalid for that type. For example, a header containing an ampersand (SENSE&).

-102 **Syntax error**

An unrecognized command or data type was encountered. For example, a string was received when the analyzer was not expecting to receive a string.

-103 **Invalid separator**

The parser was expecting a separator and encountered an illegal character. For example, the semicolon was omitted after a program message unit, *RST:TRIG.

-104 **Data type error**

The parser recognized an unallowed data element. For example, numeric or string data was expected but block data was encountered.

-105 **GET not allowed**

A Group Execute Trigger (GET) was received within a program message (see IEEE 488.2, 7.7).

-108 **Parameter not allowed**

More parameters were received than expected for the header. For example, the *SRE command only accepts one parameter, so receiving *SRE 4, 16 is not allowed.

-109 **Missing parameter**

Fewer parameters were received than required for the header. For example, the *SRE command requires one parameter, so receiving only *SRE is not allowed.

-110 **Command header error**

An error was detected in the header. This error message is used when the analyzer cannot detect the more specific errors described for errors -111 through -119.

-111 **Header separator error**

A character that is not a legal header separator was encountered while parsing the header. For example, no white space followed the header, thus *SRE4 is an error.

-112 Program mnemonic too long

The header contains more than twelve characters (see IEEE 488.2, 7.6.1.4.1).

-113 Undefined header

The header is syntactically correct, but it is undefined for the analyzer. For example, *XYZ is not defined for the analyzer.

-114 Header Suffix out of range

The value of a numeric suffix attached to a program mnemonic makes the header invalid.

-120 Numeric data error

This error, as well as errors –121 through –129, are generated when parsing a data element that appears to be numeric, including the nondecimal numeric types. This particular error message is used if the analyzer cannot detect a more specific error.

-121 Invalid character in number

An invalid character for the data type being parsed was encountered. For example, an alpha character in a decimal numeric or a “9” in octal data.

-123 Exponent too large

The magnitude of the exponent was larger than 32000 (see IEEE 488.2, 7.7.2.4.1).

-124 Too many digits

The mantissa of a decimal numeric data element contains more than 255 digits excluding leading zeros (see IEEE 488.2, 7.7.2.4.1).

-128 Numeric data not allowed

A legal numeric data element was received, but the analyzer does not accept it in this position for a header.

-130 Suffix error

This error, as well as errors –131 through –139, are generated when parsing a suffix. This particular error message is used if the analyzer cannot detect a more specific error.

-131 Invalid suffix

The suffix does not follow the syntax described in IEEE 488.2, 7.7.3.2, or the suffix is inappropriate for the analyzer.

-134 Suffix too long

The suffix contained more than 12 characters (see IEEE 488.2, 7.7.3.4).

-138 Suffix not allowed

A suffix was encountered after a numeric element that does not allow suffixes.

-140 Character data error

This error, as well as errors –141 through –148, are generated when analyzing the syntax of a character data element. This particular error message is used if the analyzer cannot detect a more specific error.

-141 Invalid character data

Either the character data element contains an invalid character or the particular element received is not valid for the header.

-144 Character data too long

The character data element contains more than twelve characters (see IEEE 488.2, 7.7.1.4).

-148 Character data not allowed

A legal character data element was encountered where prohibited by the analyzer.

-150 String data error

This error, as well as errors –151 and –158, are generated when analyzing the syntax of a string data element. This particular error message is used if the analyzer cannot detect a more specific error.

-151 Invalid string data

A string data element was expected, but was invalid for some reason (see IEEE 488.2, 7.7.5.2). For example, an END message was received before the terminal quote character.

-158 String data not allowed

A string data element was encountered but was not allowed by the analyzer at this point in parsing.

-160 Block data error

This error, as well as errors –161 and –168, are generated when analyzing the syntax of a block data element. This particular error message is used if the analyzer cannot detect a more specific error.

-161 Invalid block data

A block data element was expected, but was invalid for some reason (see IEEE 488.2, 7.7.6.2). For example, an END message was received before the length was satisfied.

-168 Block data not allowed

A legal block data element was encountered but was not allowed by the analyzer at this point in parsing.

-200 Execution error

This is the generic syntax error that the analyzer cannot detect more specific errors. This code indicates only that an execution error as defined in IEEE 488.2, 11.5.1.1.5 has occurred.

-210 Trigger error

A trigger related error occurred. This error message is used when the analyzer cannot detect the more specific errors described for errors -211 through -219.

-211 Trigger ignored

A GET, *TRG, or triggering signal was received and recognized by the analyzer but was ignored because of analyzer timing considerations. For example, the analyzer was not ready to respond.

-213 Init ignored

A request for a measurement initiation was ignored as another measurement was already in progress.

-220 Parameter error

Indicates that a program data element related error occurred. This error message is used when the analyzer cannot detect the more specific errors described for errors -221 through -229.

-221 Settings conflict

A legal program data element was parsed but could not be executed due to the current device state (see IEEE 488.2, 6.4.5.3 and 11.5.1.1.5).

-222 Data out of range

A legal program data element was parsed but could not be executed because the interpreted value was outside the legal range as defined by the analyzer (see IEEE 488.2, 11.5.1.1.5).

-223 Too much data

A legal program data element of block, expression, or string type was received that contained more data than the analyzer could handle due to memory or related device-specific requirements.

-224 Illegal parameter value

Used where exact value, from a list of possibilities, was expected.

-225 Data out of memory

The analyzer has insufficient memory to perform the requested operation.

-230 Data corrupt or stale

Possibly invalid data. New reading started but not completed since last access.

-231 Data questionable

Measurement accuracy is suspect.

-240 Hardware error

A legal program command or query could not be executed because of a hardware problem in the analyzer. Definition of what constitutes a hardware problem is completely device-specific. This error message is used when the analyzer cannot detect the more specific errors described for errors -241 through -249.

-241 Hardware missing

A legal program command or query could not be executed because of missing analyzer hardware. For example, an option was not installed.

-250 Mass storage error

A mass storage error occurred. This error message is used when the analyzer cannot detect the more specific errors described for errors -251 through -259.

-256 File name not found

A legal program command could not be executed because the file name on the device media was not found: for example, an attempt was made to read or copy a nonexistent file.

-257 File name error

A legal program command or query could not be executed because the file name on the device media was in error. For example, an attempt was made to copy to a duplicate file name. The definition of what constitutes a file name error is device-specific.

-280 Program error

A downloaded program-related execution error occurred. This error message is used when the analyzer cannot detect the more specific errors described for errors -281 through -289.

-281 Cannot create program

An attempt to create a program was unsuccessful. A reason for the failure might include not enough memory.

-282 Illegal program name

The name used to reference a program was invalid. For example, redefining an existing program, deleting a nonexistent program, or in general, referencing a nonexistent program.

-283 Illegal variable name

An attempt was made to reference a nonexistent variable in a program.

-284 Program currently running

Certain operations dealing with programs may be illegal while the program is running. For example, deleting a running program might not be possible.

-285 Program syntax error

A syntax error appears in a downloaded program. The syntax used when parsing the downloaded program is device-specific.

-286 Program runtime error

A program runtime error of the HP Instrument BASIC has occurred. To get a more specific error information, use the ERRM\$ or ERRN command of the HP Instrument BASIC.

-310 System error

Some error, termed "system error" by the analyzer, has occurred.

-311 Memory error

An error was detected in the analyzer's memory.

-330 Self-test failed

A self-test failed. Contact your nearest Hewlett-Packard office or see the *Service Manual* for troubleshooting.

-350 Queue overflow

A specific code entered into the queue in lieu of the code that caused the error. This code indicates that there is no room in the queue and an error occurred but was not recorded.

-400 Query errors

This is the generic query error that the analyzer cannot detect more specific errors. This code indicates only that a query error as defined in IEEE 488.2, 11.5.1.1.7 and 6.3 has occurred.

-410 Query INTERRUPTED

A condition causing an interrupted query error occurred (see IEEE 488.2, 6.3.2.3). For example, a query followed by DAB or GET before a response was completely sent.

-420 Query UNTERMINATED

A condition causing an unterminated query error occurred (see IEEE 488.2, 6.3.2.2). For example, the analyzer was addressed to talk and an incomplete program message was received by the controller.

-430 Query DEADLOCKED

A condition causing a deadlocked query error occurred (see IEEE 488.2, 6.3.1.7). For example, both input buffer and output buffer are full and the analyzer cannot continue.

Index

B

<*block*>, 1-7

C

calibration array, F-1
calibration coefficient, H-2
calibration type, F-1
command abbreviation, 1-5
common command, 1-3
convention, 2-2

D

data format, H-1
data level, H-2
data transfer, H-1

E

error corrected data, H-2
error message, Messages-1
Event Status Register B, D-2, D-3

F

formatted data, H-2

I

Instrument Event Status Register, D-2, D-3

K

key code, G-1

M

manual changes, A-1

N

<*numeric*>, 1-6

O

Operation Status Negative Transition Filter,
D-5
Operation Status Positive Transition Filter,
D-5
Operation Status Register, D-2, D-4
OSNT, D-5
OSPT, D-5

Q

Questionable Status Register Bit, D-2

R

raw data, H-2

S

SCPI command, 1-3
serial number, A-3
simple command, 1-3
standard class, F-1
Standard Event Status Register, D-2, D-3
Status Byte, D-2
status reporting, D-1
<*string*>, 1-6
suffix, 1-6

T

trigger system, E-1