

# **Installation Guide**

**HP 70909A and HP 70910A**

**RF Section**



**HP Part No. 70909-90002**  
**Printed in USA April 1993**

**Notice**

The information contained in this document is subject to change without notice.

Hewlett-Packard makes no warranty of any kind with regard to this material, including, but not limited to, the implied warranties of merchantability and fitness for a particular purpose. Hewlett-Packard shall not be liable for errors contained herein or for incidental or consequential damages in connection with the furnishing, performance, or use of this material.

**Restricted Rights Legend.**

Use, duplication, or disclosure by the U.S. Government is subject to restrictions as set forth in subparagraph (c) (1) (ii) of the Rights in Technical Data and Computer Software clause at DFARS 252.227-7013 for DOD agencies, and subparagraphs (c) (1) and (c) (2) of the Commercial Computer Software Restricted Rights clause at FAR 52.227-19 for other agencies.

©Copyright Hewlett-Packard Company 1991, 1993

All Rights Reserved. Reproduction, adaptation, or translation without prior written permission is prohibited, except as allowed under the copyright laws.

1400 Fountaingrove Parkway, Santa Rosa, CA 95403-1799, USA

---

## Certification

Hewlett-Packard Company certifies that this product met its published specifications at the time of shipment from the factory. Hewlett-Packard further certifies that its calibration measurements are traceable to the United States National Institute of Standards and Technology, to the extent allowed by the Institute's calibration facility, and to the calibration facilities of other International Standards Organization members.

---

## Warranty

This Hewlett-Packard instrument product is warranted against defects in material and workmanship for a period of one year from date of shipment. During the warranty period, Hewlett-Packard Company will, at its option, either repair or replace products which prove to be defective.

For warranty service or repair, this product must be returned to a service facility designated by Hewlett-Packard. Buyer shall prepay shipping charges to Hewlett-Packard and Hewlett-Packard shall pay shipping charges to return the product to Buyer. However, Buyer shall pay all shipping charges, duties, and taxes for products returned to Hewlett-Packard from another country.

Hewlett-Packard warrants that its software and firmware designated by Hewlett-Packard for use with an instrument will execute its programming instructions when properly installed on that instrument. Hewlett-Packard does not warrant that the operation of the instrument, or software, or firmware will be uninterrupted or error-free.

### LIMITATION OF WARRANTY

The foregoing warranty shall not apply to defects resulting from improper or inadequate maintenance by Buyer, Buyer-supplied software or interfacing, unauthorized modification or misuse, operation outside of the environmental specifications for the product, or improper site preparation or maintenance.

NO OTHER WARRANTY IS EXPRESSED OR IMPLIED. HEWLETT-PACKARD SPECIFICALLY DISCLAIMS THE IMPLIED WARRANTIES OF MERCHANTABILITY AND FITNESS FOR A PARTICULAR PURPOSE.

### EXCLUSIVE REMEDIES

THE REMEDIES PROVIDED HEREIN ARE BUYER'S SOLE AND EXCLUSIVE REMEDIES. HEWLETT-PACKARD SHALL NOT BE LIABLE FOR ANY DIRECT, INDIRECT, SPECIAL, INCIDENTAL, OR CONSEQUENTIAL DAMAGES, WHETHER BASED ON CONTRACT, TORT, OR ANY OTHER LEGAL THEORY.

---

## Assistance

*Product maintenance agreements and other customer assistance agreements are available for Hewlett-Packard products.*

*For any assistance, contact your nearest Hewlett-Packard Sales and Service Office.*

---

## Safety Symbols

The following safety symbols are used throughout this manual. Familiarize yourself with each of the symbols and its meaning before operating this instrument.

---

**Caution**      The *caution* sign denotes a hazard. It calls attention to a procedure which, if not correctly performed or adhered to, could result in damage to or destruction of the instrument. Do not proceed beyond a *caution* sign until the indicated conditions are fully understood and met.

---

**Warning**      The *warning* sign denotes a hazard. It calls attention to a procedure which, if not correctly performed or adhered to, could result in injury or loss of life. Do not proceed beyond a *warning* sign until the indicated conditions are fully understood and met.

---

---

## General Safety Considerations

---

**Warning**     *Before this instrument is switched on, make sure it has been properly grounded through the protective conductor of the ac power cable to a socket outlet provided with protective earth contact.*

**Any interruption of the protective (grounding) conductor, inside or outside the instrument, or disconnection of the protective earth terminal can result in personal injury.**

---

**Warning**     **There are many points in the instrument which can, if contacted, cause personal injury. Be extremely careful.**

**Any adjustments or service procedures that require operation of the instrument with protective covers removed should be performed only by trained service personnel.**

---

**Caution**     *Before this instrument is switched on, make sure its primary power circuitry has been adapted to the voltage of the ac power source.*

**Failure to set the ac power input to the correct voltage could cause damage to the instrument when the ac power cable is plugged in.**

---

# Installation at a Glance

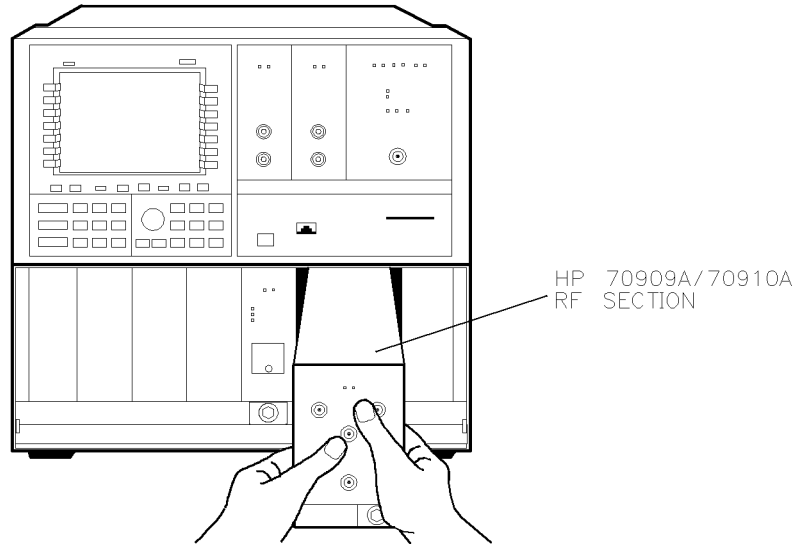

## ACCESSORIES AND DOCUMENTATION SUPPLIED

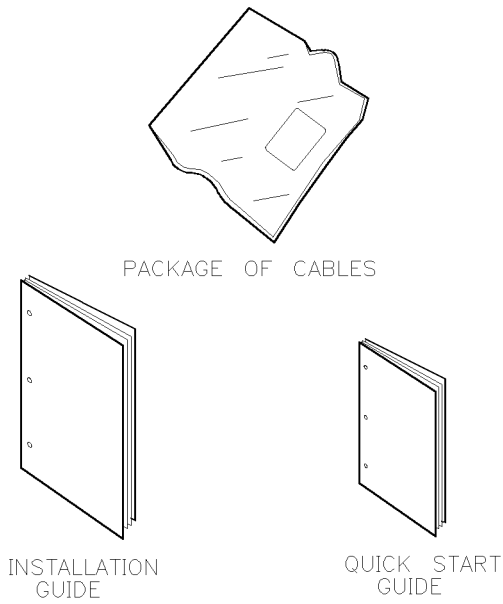

## TOOLS NEEDED

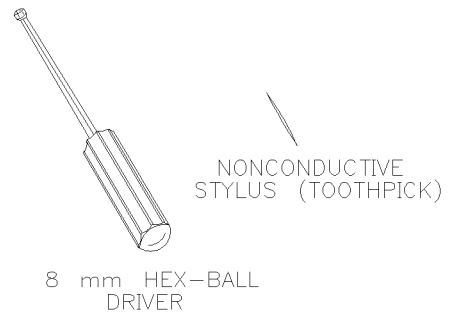

dcb23

The HP 70909A RF section and HP 70910A RF section are preselected microwave front-end modules that are used in an HP 70000 Series modular spectrum analyzer system. A standard modular spectrum analyzer system includes an RF section, IF section, local oscillator, an optional display, and an optional precision frequency reference.

### **Equipment and documentation supplied**

This package contains:

- HP 70909A RF section or HP 70910A RF section
- *HP 71209A Quick Start Guide*
- *HP 70909A and HP 70910A Installation Guide*
- Rear panel cabling for your new RF section

### **Tools needed**

Before installation, assemble these tools:

- A long or short 8 mm hex-ball driver
- A nonconductive stylus, such as a toothpick or similar object, for setting address switches

### **Antistatic precautions**

Electrical components are easily damaged by small amounts of static electricity. If possible, work at a static-safe work station.

### **Installation overview**

The installation procedure for the HP 70909A or HP 70910A RF section is straightforward. The following major steps are included:

- Step 1. Switch off the system's ac line power
- Step 2. Disconnect the existing RF section's rear panel cables
- Step 3. Remove the existing RF section
- Step 4. Unpack your new RF section
- Step 5. Check or set the HP-MSIB address on your new RF section
- Step 6. Install your new RF section
- Step 7. Connect the new RF section's rear panel cables
- Step 8. Switch on the system's ac line power
- Step 9. Check proper operation of your new RF section

---

## In This Book

This book describes all of the installation procedures necessary to install and check the proper operation of either an HP 70909A RF section or an HP 70910A RF section in an HP 70000 Series modular spectrum analyzer system. It also contains information on what to do if problems occur during installation.

Each module in the HP 70000 Series modular spectrum analyzer system is shipped with its own installation guide. For further information related to the installation of additional and alternate modules that can be used in this system, refer to that module's installation guide.

Chapter 1 of this book presents step-by-step instructions that are required for proper installation of either an HP 70909A or HP 70910A RF section in an HP 70000 Series modular spectrum analyzer system.

Chapter 2 of this book presents information to help identify and resolve problems that may occur with the installation of your HP 70909A or HP 70910A RF section.

For information on setting the HP-MSIB address switches of an HP 70909A or HP 70910A RF section, refer to the *HP 70000 Modular Spectrum Analyzer Installation and Verification Manual*.



# Contents

---

## 1. Installation

Step 1. Switch off the system's ac line power . . . . .	1-2
Step 2. Disconnect the existing RF section's rear panel cables . . . . .	1-3
Step 3. Remove the existing RF section . . . . .	1-4
Step 4. Unpack your new RF section . . . . .	1-5
Step 5. Check or set the HP-MSIB address on your new RF section . . . . .	1-6
Step 6. Install your new RF section . . . . .	1-7
Step 7. Connect the new RF section's rear panel cables . . . . .	1-8
Step 8. Switch on the system's ac line power . . . . .	1-9
Step 9. Check proper operation of your new RF section . . . . .	1-10

## 2. If you have problems with installation

If the system's power-on self test fails . . . . .	2-2
If your RF section is powered on but not responding correctly . . . . .	2-4
If the STATUS ERR indicator LED on your new RF section is flashing . . . . .	2-5
If more than one module's error indicator is flashing . . . . .	2-6
If hardware errors messages occur . . . . .	2-7
If you require additional technical resources . . . . .	2-9
Before calling or returning your RF section for service . . . . .	2-9
Calling Hewlett-Packard for service . . . . .	2-9
Returning your equipment for service . . . . .	2-11

# Figures

---

2-1. Line Voltage Selector . . . . .	2-2
2-2. Line Fuse Removal and Replacement . . . . .	2-2

# Tables

---

2-1. Hewlett-Packard Sales and Service Offices . . . . .	2-10
2-2. Packaging and Contents . . . . .	2-12

# Installation

---

This chapter contains step-by-step instructions that are required for proper installation of either an HP 70909A RF section or an HP 70910A RF section in an HP 70000 Series modular spectrum analyzer system.

## Tools needed

Before installation, assemble these tools:

- A long 8 mm hex-ball driver (HP part number 8710-1307) or a short 8 mm hex-ball driver (HP part number 8710-1651)
- A nonconductive stylus, such as a toothpick or similar object, for setting address switches

## Antistatic precautions

Electrical components are easily damaged by small amounts of static electricity. If possible, work at a static-safe work station. (Refer to the *HP 70000 Modular Spectrum Analyzer Installation and Verification Manual* for information.)

## Installation overview

The installation procedure for the HP 70909A or HP 70910A RF section is straightforward. The following major steps are included:

- Step 1. Switch off the system's ac line power
- Step 2. Disconnect the existing RF section's rear panel cables
- Step 3. Remove the existing RF section
- Step 4. Unpack your new RF section
- Step 5. Check or set the HP-MSIB address on your new RF section
- Step 6. Install your new RF section
- Step 7. Connect the new RF section's rear panel cables
- Step 8. Switch on the system's ac line power
- Step 9. Check proper operation of your new RF section

## Step 1. Switch off the system's ac line power

**1** Before removing any existing modules or disconnecting any cables from your system, switch off the ac line power to the HP 70000 Series modular spectrum analyzer system's display and mainframe.

If you do not have a standard system configuration or if you have problems determining which cables to disconnect, refer to the *HP 70000 Modular Spectrum Analyzer Installation and Verification Manual*.

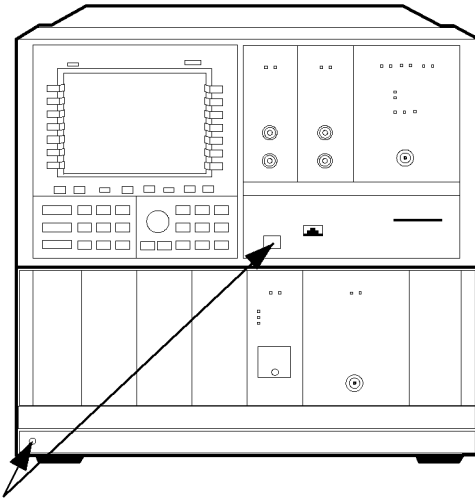

POWER SWITCHES

DCB7



DCB16

## Step 2. Disconnect the existing RF section's rear panel cables

**1** Disconnect the SMB cable from the existing RF section's 21,4 MHz OUT connector.

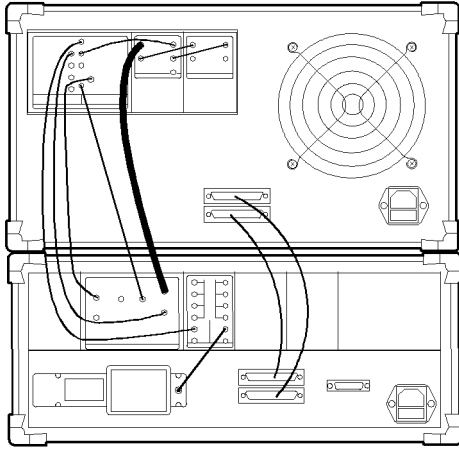

DCB14

**2** Disconnect the SMB cable from the existing RF section's 300 MHz IN connector.

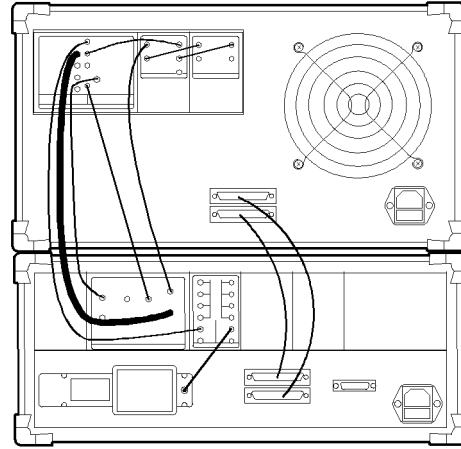

DCB15

**3** Disconnect the SMB cable from the existing RF section's TUNE SPAN connector.

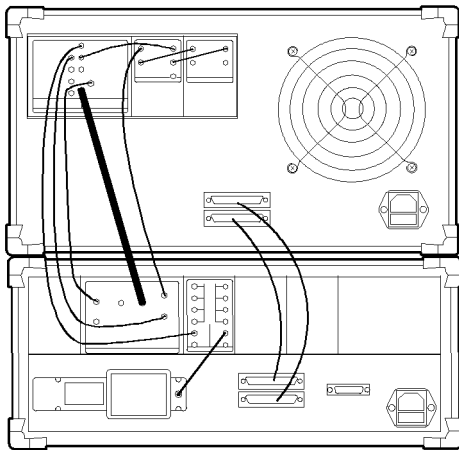

DCB13

**4** Disconnect the SMA flexible cable from the existing RF section's 1ST LO IN connector.

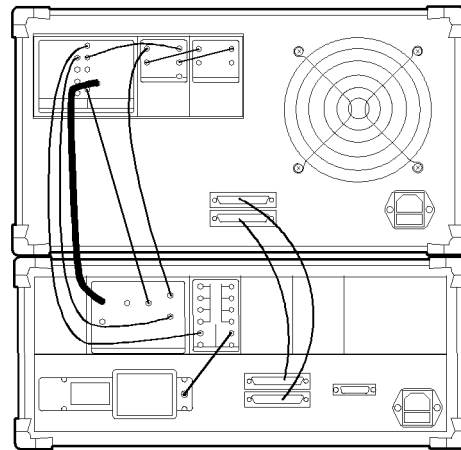

DCB19

### Step 3. Remove the existing RF section

**1** Open the mainframe front-panel door to expose the hex-lock screw.

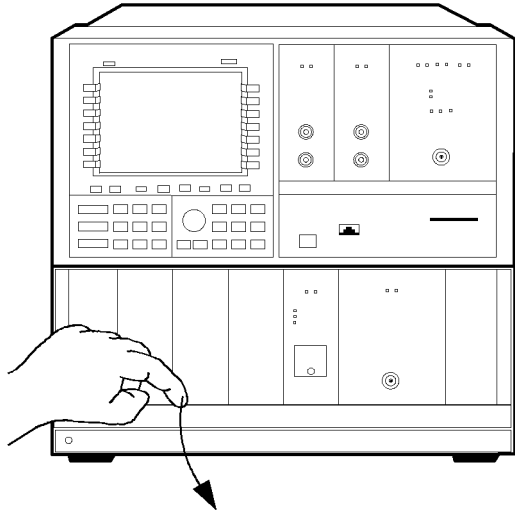

DCB8

**2** Using an 8 mm hex-ball driver, remove the existing RF section to make room for your new RF section.

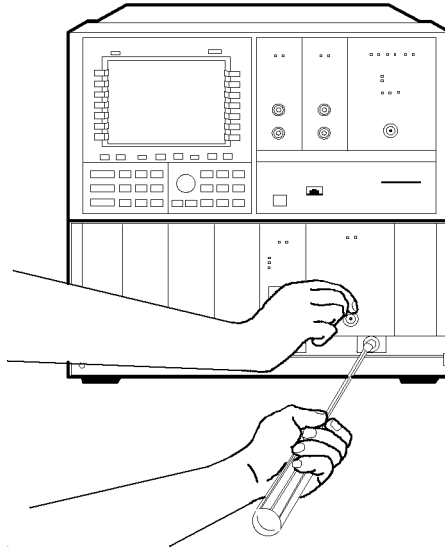

DCB11

An HP 70909A or HP 70910A RF section occupies two adjacent 1/8 module slots in an HP 70000 Series modular spectrum analyzer system mainframe.

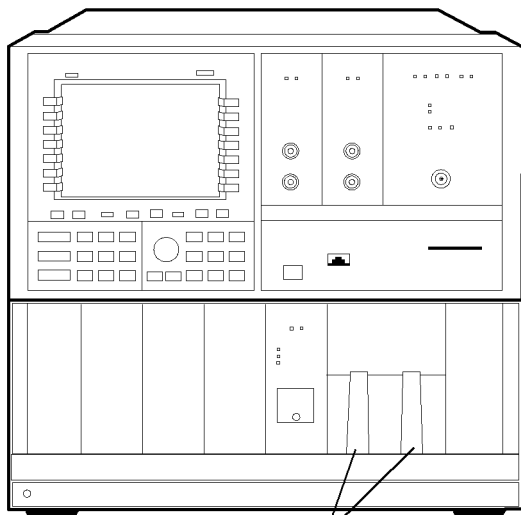

2 ADJACENT SLOTS

DCB9

## Step 4. Unpack your new RF section

**1** Unpack your new HP 70909A RF section or HP 70910A RF section from its shipping container and inspect it thoroughly to ensure that it was not damaged during shipment.

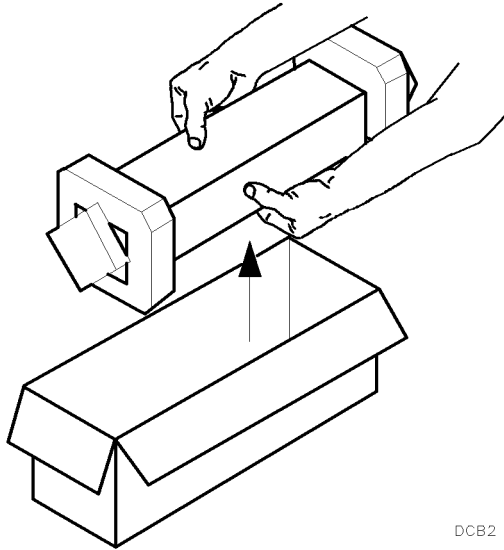

DCB2

**2** Verify that all parts and materials were included in the shipping container.

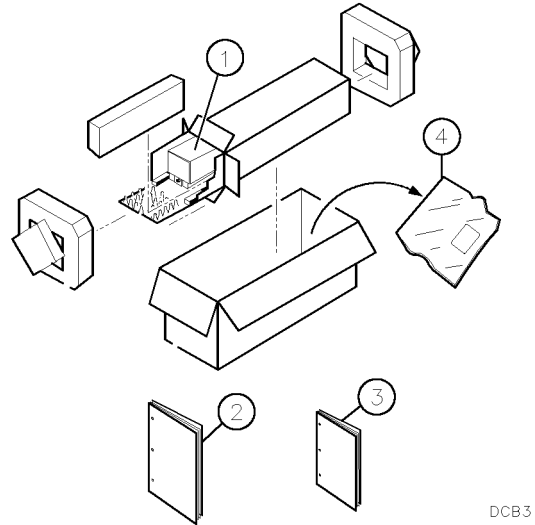

DCB3

1. HP 70909A RF section or HP 70910A RF section
2. *HP 70909A and HP 70910A Installation Guide*
3. *HP 71209A Quick Start Guide*
4. Package of cables.

## Step 5. Check or set the HP-MSIB address on your new RF section

**1** Locate the HP-MSIB address switches on the left-rear side of your new RF section.

During the manufacturing process, each module in the HP 70000 Series modular spectrum analyzer system is set to a default HP-MSIB address.

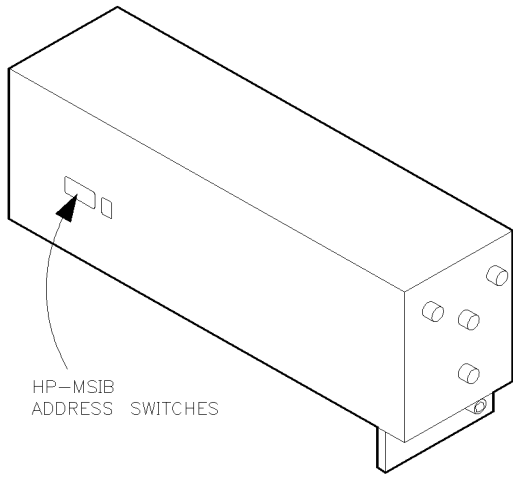

DCB5

**2** Check that the HP-MSIB address on your new RF section is set to row 6 and column 18.

If necessary, use a nonconductive stylus, such as a toothpick or similar object, to set the HP-MSIB address switches.

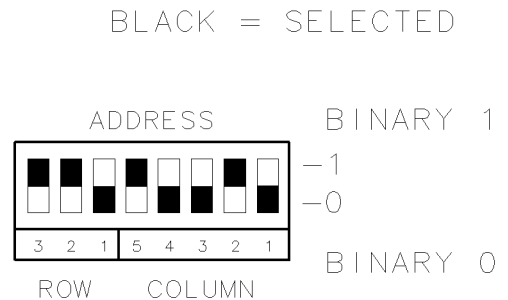

	BINARY	DECIMAL
ROW:	110	6
COLUMN:	10010	18

DCB6

Each module in an HP 70000 Series modular spectrum analyzer system must have a unique address.

To configure your new RF section with a different HP-MSIB address other than its default, refer to the *HP 70000 Modular Spectrum Analyzer Installation and Verification Manual*.



DCB16



## Step 6. Install your new RF section

**1** Install your new RF section into the mainframe.

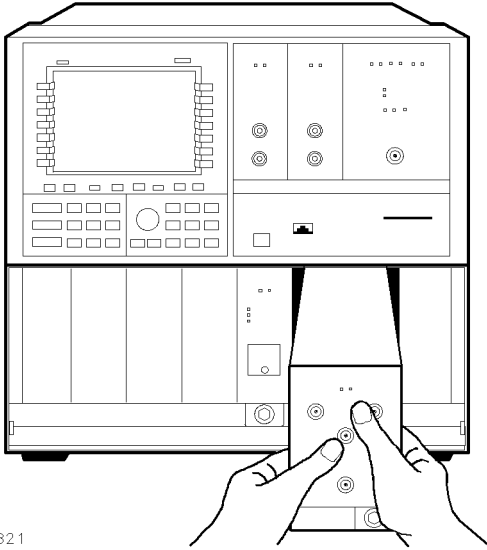

**2** Press against your new RF section's front panel while tightening the hex-nut latch with an 8 mm hex-ball driver. This locks your new RF section into position.

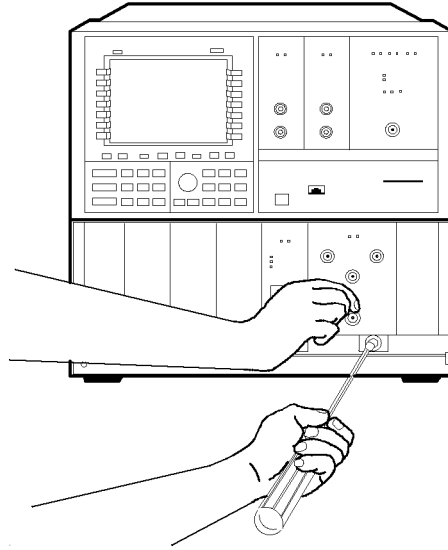

**3** Close the mainframe front-panel door to cover the hex-lock screw.

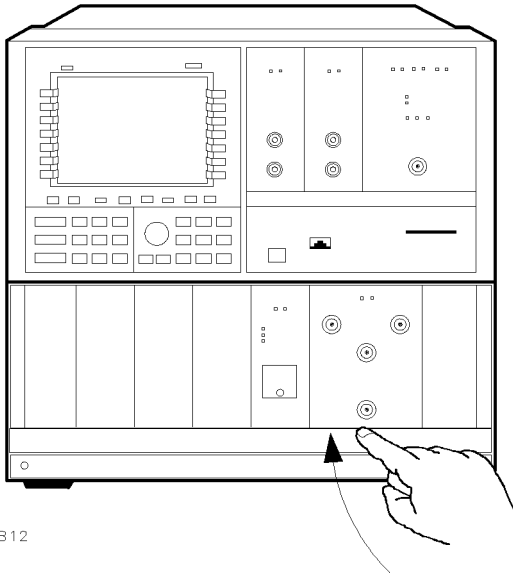

## Step 7. Connect the new RF section's rear panel cables

**1** Connect an SMB cable from your new RF section's 21.4 MHz OUT connector to the HP 70903A IF section's 21.4 MHz IN connector.

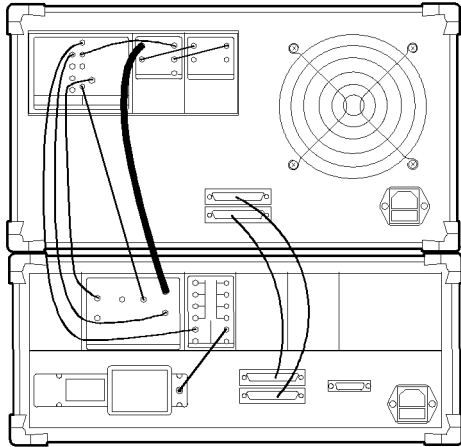

DCB14

**2** Connect an SMB cable from the LO section's 300 MHz OUT connector to your new RF section's 300 MHz IN connector.

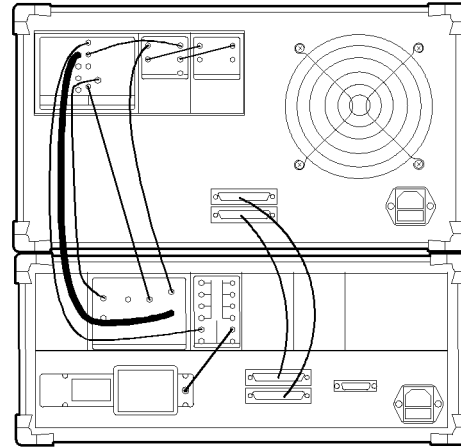

DCB15

**3** Connect an SMB cable from the LO section's TUNE SPAN connector to your new RF section's TUNE SPAN connector.

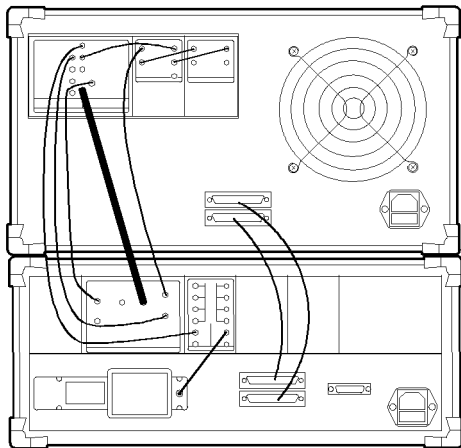

DCB13

**4** Connect an SMA flexible cable from the LO section's LO OUT connector to your new RF section's 1ST LO IN connector.

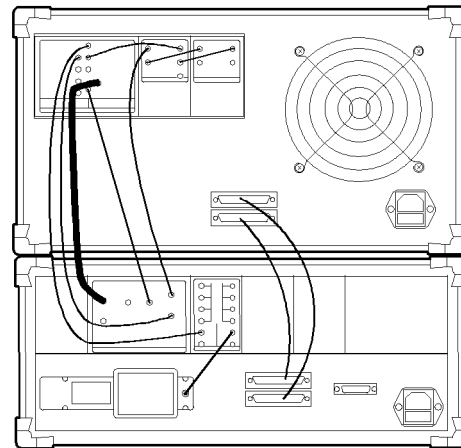

DCB19

## Step 8. Switch on the system's ac line power

**1** Set the line-voltage selector on your HP 70000 Series modular spectrum analyzer system display and mainframe to the voltage corresponding to the power source used. The line-voltage selectors are located on the left side of the HP 70004A color display and on the bottom of the HP 70001A mainframe.

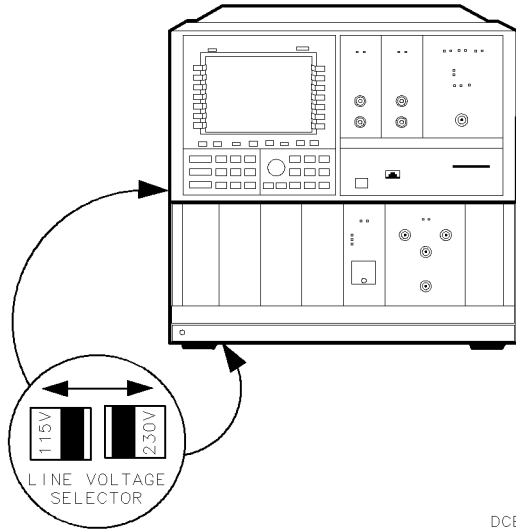

**2** Connect the ac power cords to the rear of the HP 70000 Series modular spectrum analyzer system display and mainframe. Then connect the other ends of the ac power cords to the line voltage.

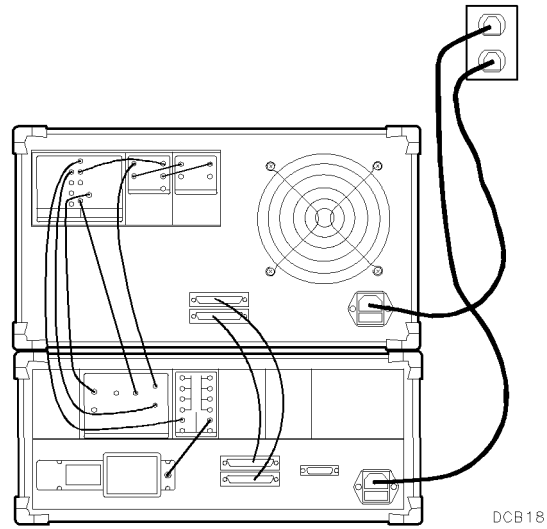

### Caution



Before turning this instrument on, make sure the line-voltage selector is set to the voltage of the ac power source:

- 115 V position for 90 to 132 V ac line input voltages at 50, 60, or 400 Hz
- 230 V position for 198 to 264 V ac line input voltages at 50 or 60 Hz

**3** Switch on the ac line power to the HP 70000 Series modular spectrum analyzer system display and mainframe.

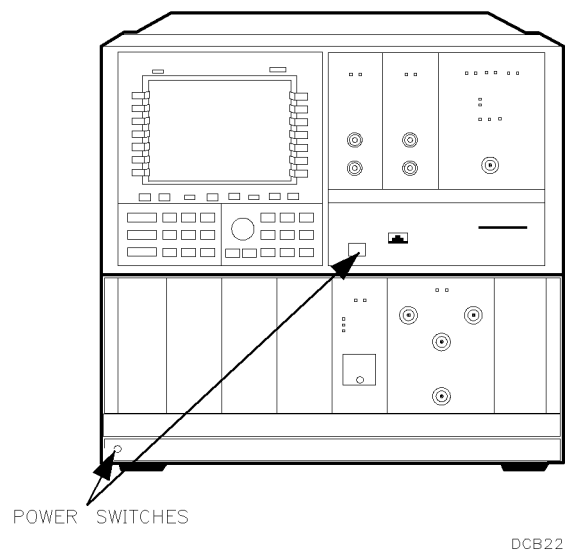

## Step 9. Check proper operation of your new RF section

**1** Check that the MEASURE LED is blinking at the end of the power-on self test.

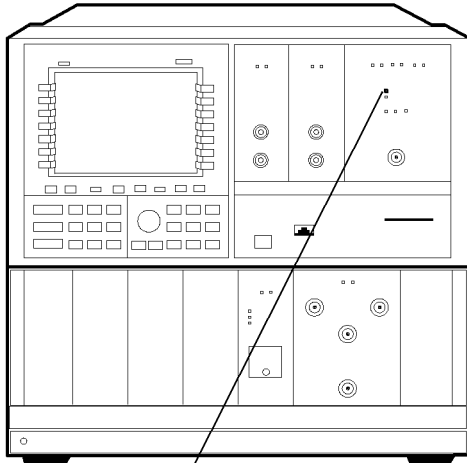

MEASURE LED

DCB24

Each time the HP 70000 Series modular spectrum analyzer system is turned on, the following actions take place:

1. The system runs through an initializing routine (power-on self test) during which the front-panel STATUS LEDs on each module flash on momentarily and then turn off again.
2. If the power-on self test passes, the MEASURE LED on the LO module starts blinking on and off, being triggered by the system sweep, and the ACT LED on each active module's front-panel is turned on.

If you have problems with installation, refer to Chapter 2.

There are no verification tests or specifications for the RF section by itself, it must be tested in a system. For information on system verification tests and system specifications, refer to the *HP 70000 Modular Spectrum Analyzer Installation and Verification Manual*.



DCB16

## **If you have problems with installation**

---

This chapter contains information to help identify and resolve problems that may occur with the installation of your HP 70909A or HP 70910A RF section.

Symptoms to various problems are listed at the top of each page.

Most symptoms have a brief description or explanation to help provide more insight into their cause. A possible cause for the symptom and a checklist of possible solutions are then presented. Use this checklist as an aid to correct the problem.

If a problem cannot be resolved, you can return the equipment to Hewlett-Packard for servicing. Instructions for returning your RF section to Hewlett-Packard for servicing are provided in "Before calling or returning your RF section for service".

---

## If the system's power-on self test fails

Each time the HP 70000 Series modular spectrum analyzer system is turned on, the following actions take place:

1. The system runs through an initializing routine (power-on self test) during which the front-panel STATUS LEDs on each module flash on momentarily and then turn off again.
2. If the power-on self test passes, the MEASURE LED on the LO module starts blinking on and off, being triggered by the system sweep, and the ACT LED on each active module's front-panel is turned on.

If this sequence of events does not occur, then one or more of the modules in the system is not functioning properly.

To solve this problem:

- Check that the RF section is powered on.
- Check that the HP 70000 Series modular spectrum analyzer system display and mainframe are plugged into the proper ac line voltage.
- Check that the line socket has ac line voltage.
- Check that the line voltage selector switch is set to the correct voltage for the ac line voltage being used.

The line voltage selector switch is located on the left side of the HP 70004A display or on the bottom of the HP 70001A mainframe.

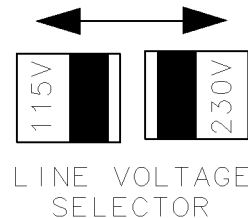

dcb26

**Figure 2-1. Line Voltage Selector**

- Check the line fuse on the display or the mainframe to ensure that it is not damaged.

The line fuse is located inside the power-cord receptacle housing on the rear of the display and mainframe. Also included in this housing is a spare fuse. The fuse is a 5 by 20 mm fuse rated at 6.3 A, 250 V (HP part number 2110-0703). This line fuse can be used with both 120 V and 230 V line voltage.

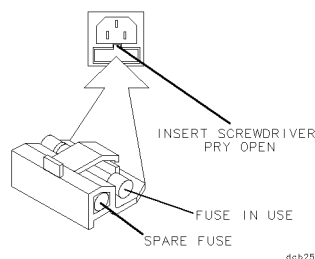

dcb25

**Figure 2-2. Line Fuse Removal and Replacement**

- If necessary, obtain HP service. (Refer to “If you require additional technical resources”.)

---

## **If your RF section is powered on but not responding correctly**

If your RF section is powered on but not responding correctly, then something may be wrong with the system setup.

To solve this problem:

- Perform the checks in the procedure “If the system’s power-on self test fails”.
- Check that other equipment, cables, and connectors are connected and operating correctly.
- Check the HP 70000 Series modular spectrum analyzer system display for error messages.
- If necessary, obtain HP service. (Refer to “If you require additional technical resources”.)



---

## **If the STATUS ERR indicator LED on your new RF section is flashing**

The HP 70909A or HP 70910A RF section communicates with the HP 70000 Series modular spectrum analyzer system over the HP-MSIB.

If the STATUS ERR indicator LED, located on the RF section's front panel, is flashing at a 1 Hz rate, the module cannot communicate over the HP-MSIB.

To solve this problem:

- Remove the RF section and reinstall it using the following steps:
  1. Switch off the system's ac line power
  2. Disconnect the RF section's rear panel cables
  3. Remove the RF section from the system
  4. Switch on the system's ac line power and check that no error LEDs are flashing on the other system modules
  5. If all other modules are working correctly, use the steps outlined in Chapter 1 to reinstall the RF section.
- Check that the HP-MSIB address is set correctly. (Refer to "Step 5. Check or set the HP-MSIB address on your new RF section" in Chapter 1.)
- If necessary, obtain HP service. (Refer to "If you require additional technical resources".)

---

## **If more than one module's error indicator is flashing**

The HP 70909A or HP 70910A RF section communicates with the HP 70000 Series modular spectrum analyzer system over the HP-MSIB.

When the error indicator LED on a module is flashing at a 1 Hz rate, then that module is not communicating over the HP-MSIB.

To solve this problem:

- Check that the HP-MSIB address is set correctly. (Refer to “Step 5. Check or set the HP-MSIB address on your new RF section” in Chapter 1.)

If two separate modules, are set to the same HP-MSIB address, this problem will occur.

- Remove all modules and reinstall them one at a time until a module that causes the ERR LED to flash is found.

Turn the power on each time after a module is removed to determine if the problem has been solved.

- If necessary, obtain HP service. (Refer to “If you require additional technical resources”.)

---

## If hardware errors messages occur

Hardware errors are generated when a module in the HP 70000 Series modular spectrum analyzer system is not working properly. These errors can occur at any time. Hardware errors range from 7000–7999. (Refer to the *HP 70909A and HP 70910A Service Guide* for information about other error messages.)

One or more of the following hardware error messages may appear on your system display:

### 7000 **ROM check error**

This hardware error occurs when the programmed checksum of U14 and U15, on the A20 Controller, does not agree with the computed checksum.

To solve this problem:

1. Refer to the *HP 70909A and HP 70910A Service Guide* for troubleshooting information.
2. If necessary, obtain HP service. (Refer to “If you require additional technical resources”.)

### 7002 **1st LO unlevelled**

This hardware error occurs when the signal of the 1st local oscillator is unlevelled.

To solve this problem:

1. Check the rear-panel 1ST LO IN connection.
2. Refer to the *HP 70909A and HP 70910A Service Guide* for troubleshooting information.
3. If necessary, obtain HP service. (Refer to “If you require additional technical resources”.)

### 7003 **2nd LO unlocked**

This hardware error occurs when the signal of the 2nd local oscillator’s phase-locked loop circuitry is not phase-locked to the 300 MHz reference signal.

To solve this problem:

1. Check the rear-panel 300 MHz IN connection.
2. Refer to the *HP 70909A and HP 70910A Service Guide* for troubleshooting information.
3. If necessary, obtain HP service. (Refer to “If you require additional technical resources”.)

### 7004 **300 MHz error**

This hardware error occurs when the power is low at the output of the A10 300 MHz amplifier, stage five.

To solve this problem:

1. Check the rear-panel 300 MHz IN connection.
2. Refer to the *HP 70909A and HP 70910A Service Guide* for troubleshooting information.
3. If necessary, obtain HP service. (Refer to “If you require additional technical resources”.)

**7047 RAM failure**

This hardware error occurs when the A20 Controller has detected one or more defective RAM devices.

To solve this problem:

1. Obtain HP service. (Refer to “If you require additional technical resources”.)

**7077 YTF drive error**

This hardware error occurs when the A20 Controller has detected an incorrect drive voltage on the A19 PS/YTF driver assembly.

To solve this problem:

1. Refer to the *HP 70909A and HP 70910A Service Guide* for troubleshooting information.
2. If necessary, obtain HP service. (Refer to “If you require additional technical resources”.)

**7078 Tune + Span error**

This hardware error occurs when the Tune+Span voltage on the A19 Power Supply/Driver assembly is low.

To solve this problem:

1. Check the rear-panel TUNE SPAN connection.
2. Refer to the *HP 70909A and HP 70910A Service Guide* for troubleshooting information.
3. If necessary, obtain HP service. (Refer to “If you require additional technical resources”.)

**7079 EEPROM check error**

This hardware error occurs when the A20 Controller has determined that the EEPROM memory is invalid. Either the EEPROM is defective or the data in the EEPROM must be reloaded.

To solve this problem:

1. Obtain HP service. (Refer to “If you require additional technical resources”.)

---

## **If you require additional technical resources**

Problems that are internal to modules, displays, or mainframes will require additional technical information. (Refer to the service documentation for the faulty modules, displays, or mainframes.)

If you do not want to repair the problem yourself, you can return the equipment to Hewlett-Packard for servicing. Instructions for returning your RF section to Hewlett-Packard for servicing are provided in “Before calling or returning your RF section for service”. You would use a similar procedure when returning other equipment.

## **Before calling or returning your RF section for service**

Before calling Hewlett-Packard or returning your HP 70909A or HP 70910A RF section for service, please perform all of the checks outlined in this chapter. If you still have a problem after performing these checks and you determine that further service is required, please read your warranty information. Warranty information is printed at the front of this installation guide.

Hewlett-Packard offers several maintenance plans to service your HP 70909A or HP 70910A RF section after warranty expiration (your Hewlett-Packard sales and service office can provide full details). If your HP 70909A or HP 70910A RF section are covered by a separate maintenance agreement, please be familiar with its terms before calling Hewlett-Packard for service.

If you want to service the HP 70909A or HP 70910A RF section yourself after warranty expiration, contact a Hewlett-Packard sales and service office to obtain the most current test and maintenance information.

## **Calling Hewlett-Packard for service**

Hewlett-Packard has sales and service offices around the world to provide complete support for your HP 70909A or HP 70910A RF section. To obtain servicing information or to order replacement parts, contact the nearest Hewlett-Packard sales and service office listed in Table 2-1.

In any correspondence or telephone conversations, refer to the HP 70909A or HP 70910A RF section by its model number and full serial number. With this information, the Hewlett-Packard representative can determine whether your unit is still within its warranty period.

**Table 2-1. Hewlett-Packard Sales and Service Offices**

**US FIELD OPERATIONS  
HEADQUARTERS**

Hewlett-Packard Company  
19320 Pruneridge Avenue  
Cupertino, CA 95014, USA  
(800) 752-0900

**California**

Hewlett-Packard Co.  
1421 South Manhattan Ave.  
Fullerton, CA 92631  
(714) 999-6700

Hewlett-Packard Co.  
301 E. Evelyn  
Mountain View, CA 94041  
(415) 694-2000

**Colorado**

Hewlett-Packard Co.  
24 Inverness Place, East  
Englewood, CO 80112  
(303) 649-5000

**Georgia**

Hewlett-Packard Co.  
2000 South Park Place  
Atlanta, GA 30339  
(404) 955-1500

**Illinois**

Hewlett-Packard Co.  
5201 Tollview Drive  
Rolling Meadows, IL 60008  
(708) 255-9800

**New Jersey**

Hewlett-Packard Co.  
120 W. Century Road  
Paramus, NJ 07653  
(201) 599-5000

**Texas**

Hewlett-Packard Co.  
930 E. Campbell Rd.  
Richardson, TX 75081  
(214) 231-6101

**EUROPEAN OPERATIONS  
HEADQUARTERS**

Hewlett-Packard S.A.  
150, Route du Nant-d'Avril  
1217 Meyrin 2/Geneva  
Switzerland  
(41 22) 780.8111

**France**

Hewlett-Packard France  
1 Avenue Du Canada  
Zone D'Activite De Courtaboeuf  
F-91947 Les Ulis Cedex  
France  
(33 1) 69 82 60 60

**Germany**

Hewlett-Packard GmbH  
Berner Strasse 117  
6000 Frankfurt 56  
West Germany  
(49 69) 500006-0

**Great Britain**

Hewlett-Packard Ltd.  
Eskdale Road, Winnersh Triangle  
Wokingham, Berkshire RG11 5DZ  
England  
(44 734) 696622

**INTERCON OPERATIONS  
HEADQUARTERS**

Hewlett-Packard Company  
3495 Deer Creek Rd.  
Palo Alto, California 94304-1316  
(415) 857-5027

**Australia**

Hewlett-Packard Australia Ltd.  
31-41 Joseph Street  
Blackburn, Victoria 3130  
(61 3) 895-2895

**Canada**

Hewlett-Packard (Canada) Ltd.  
17500 South Service Road  
Trans-Canada Highway  
Kirkland, Quebec H9J 2X8  
Canada  
(514) 697-4232

**Japan**

Yokogawa-Hewlett-Packard Ltd.  
1-27-15 Yabe, Sagamihara  
Kanagawa 229, Japan  
(81 427) 59-1311

**China**

China Hewlett-Packard, Co.  
38 Bei San Huan X1 Road  
Shuang Yu Shu  
Hai Dian District  
Beijing, China  
(86 1) 256-6888

**Singapore**

Hewlett-Packard Singapore  
Pte. Ltd.  
1150 Depot Road  
Singapore 0410  
(65) 273 7388

**Taiwan**

Hewlett-Packard Taiwan  
8th Floor, H-P Building  
337 Fu Hsing North Road  
Taipei, Taiwan  
(886 2) 712-0404

## Returning your equipment for service

If you have completed the steps outlined in the section titled “Before calling or returning your RF section for service”, use the following procedure to return your HP 70909A RF section or HP 70910A RF section to Hewlett-Packard for service:

1. Fill out a service tag (available at the end of this installation guide) and attach it to the instrument. Please be as specific as possible about the nature of the problem. Send a copy of any or all of the following information:
  - any error messages that appeared on the HP 70000 Series modular spectrum analyzer system display
  - a completed Performance Test record
  - any other specific data on the performance of the HP 70909A RF section or HP 70910A RF section

---

**Caution**      Damage can result if the original packaging materials are not used. Packaging materials should be anti-static and should cushion the RF section on all sides.

Never use styrene pellets in any shape as packaging materials. They do not adequately cushion the instrument or prevent it from moving in the shipping container. Styrene pellets can also cause equipment damage by generating static electricity or by lodging in fan motors.

---

2. Place the RF section in its original packaging materials (see Table 2-2).

If the original packaging materials are not available, you can contact a Hewlett-Packard sales and service office to obtain information on packaging materials or you may use an alternative packing material referred to as “bubble-pack”. One of the companies that makes bubble-pack is Sealed Air Corporation of Commerce, California, 90001.
3. Surround the RF section with at least 3 to 4 inches of its original packing material or bubble-pack to prevent the RF section from moving in its shipping container.
4. Place the RF section, after wrapping it with packing material, in its original shipping container or a strong shipping container that
  - is made of double-walled corrugated cardboard with 159 kg (350 lb) bursting strength.
  - The shipping container must be both large enough and strong enough to accommodate an RF section and allow at least 3 to 4 inches on all sides of the RF section for packing material.
5. Seal the shipping container securely with strong nylon adhesive tape.
6. Mark the shipping container “FRAGILE, HANDLE WITH CARE” to help ensure careful handling.
7. Retain copies of all shipping papers.

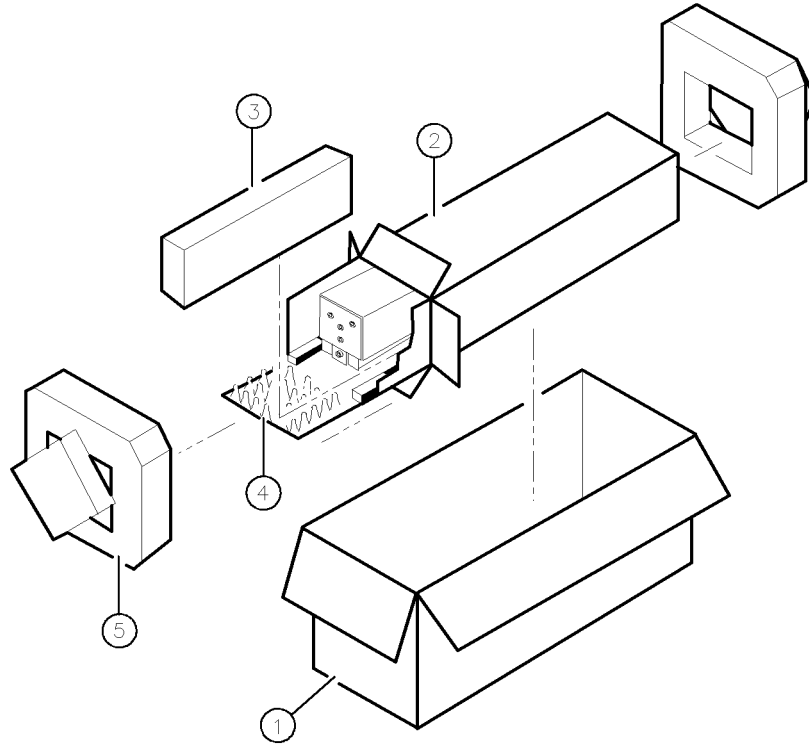

DCB1

**Table 2-2. Packaging and Contents**

Item	Description	HP Part Number	Qty
1	Carton-outer	9211-5118	1
2	Carton-inner	9211-5119	1
3	Carton-sliders	5180-2369	2
4	Foam inserts	4208-0493	2
5	Foam pads	5180-2370	2