

VECTOR VOLTMETER

8405A

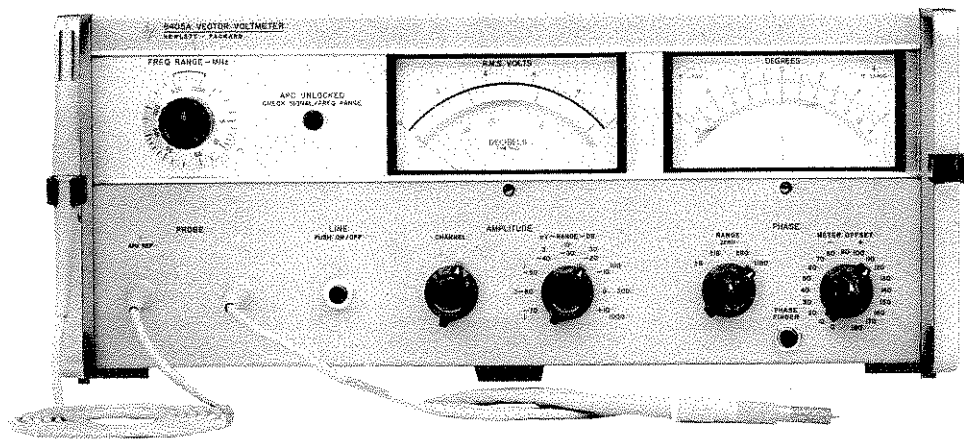

VECTOR VOLTMETER

8405A

Serial Prefix: 946-

This manual applies directly to the HP Model 8405A Vector Voltmeter having serial prefix number 946-.

Serial Prefixes Not Listed

For instruments with serial prefix above 946-, a "Manual Changes" sheet is included with this manual. The necessary changes required to adapt this manual for instruments with serial prefix 838 and below can be found in Appendix I.

NOTE

See inside rear cover for overall schematic.

Copyright HEWLETT-PACKARD COMPANY 1966
1501 PAGE MILL ROAD, PALO ALTO, CALIFORNIA, U.S.A

Manual Part No. 08405-90024

Microfiche No. 08405-90025

Printed MAY 1971

HEWLETT  PACKARD

TABLE OF CONTENTS

Section		Page	Section		Page
I	GENERAL INFORMATION	1-1	IV	PRINCIPLES OF OPERATION	4-1
	1-1. Description	1-1		4-1. General	4-1
	1-6. Accessories Furnished	1-2		4-3. Simplified Block Diagram	
	1-13. Accessories Available	1-2		Description	4-1
	1-19. Instrument Covered by			4-9. Detailed Block Diagram	
	Manual	1-3		Description	4-1
	1-21. Instrument Options	1-3		4-10. Circuit Sections	4-1
II	INSTALLATION	2-1		4-14. Circuit Descriptions	4-1
	2-1. Unpacking and Inspection	2-1		4-16. The RF-to-IF Converters	4-1
	2-3. Preparation for Use	2-1		4-19. Sampling	4-1
	2-4. Power Requirements	2-1		4-21. Sampler	4-3
	2-6. 115/230 Volt Operation	2-1		4-24. Circuit Description	4-4
	2-9. Power Cable	2-1		4-32. The Automatic Phase	
	2-12. Cooling	2-1		Control	4-5
	2-14. Bench Operation	2-1		4-36. Search Section	4-5
	2-16. Rack Mounting	2-1	V	MAINTENANCE	5-1
	2-18. Repackaging for Shipment	2-1		5-1. Introduction	5-1
III	OPERATING INSTRUCTIONS	3-1		5-3. Performance Testing	5-1
	3-1. Introduction	3-1		5-6. Adjustments	5-1
	3-4. Applications	3-1		5-9. Troubleshooting	5-1
	3-6. Panel Features	3-1		5-10. Locating Trouble	5-1
	3-8. Operating Procedures	3-1		5-13. Component Trouble	
	3-10. General Operating and			Isolation	5-1
	Measurement Considerations	3-1		5-15. In-Circuit Testing	5-1
	3-11. Initial Turn-On	3-1		5-18. Out-of-Circuit Testing	5-2
	3-12. Input Probes	3-1		5-20. Repair and RF Replacement	5-3
	3-13. Mechanical Features	3-1		5-22. Etched Circuits	5-3
	3-14. Electrical Features	3-1		5-26. Transistor Replacement	5-4
	3-15. Input Signals	3-1		5-27. Diode Replacement	5-4
	3-20. In-Circuit Measurements	3-5	VI	REPLACEABLE PARTS	6-1
	3-22. Circuit Loading	3-5		6-1. Introduction	6-1
	3-24. Circuit Impedance	3-5		6-4. Ordering Information	6-1
	3-26. Sampling Signal	3-5	VII	SCHEMATIC DIAGRAMS	7-1
	3-28. Probe Grounding	3-5		7-1. Introduction	7-1
	3-30. Coaxial Measurements	3-5		7-3. Replacement Information	7-1
	3-32. Swept-Frequency Operation	3-5		APPENDIX	i-1
	3-34. Zero-Setting the Phasemeter	3-5			
	3-37. 20 kHz IF Outputs	3-6			
	3-40. Use of Supplied Probe				
	Accessories	3-6			

LIST OF ILLUSTRATIONS

Number	Title	Page	Number	Title	Page
1-1.	Model 8405A Vector Voltmeter and Supplied Accessories	1-0	4-2.	Basic Input Circuitry	4-3
2-1.	Preparation for Rack Mounting	2-0	4-3.	Fast Waveform Reproduced on Slower Time Base By Sampling	4-3
3-1.	Front Panel Features	3-0	4-4.	Simplified Diagram of a Sampler	4-4
3-2.	Rear Panel Features	3-2	5-1.	Transistor Biasing Characteristics	5-3
3-3.	Transmission Line Measurements	3-3	5-2.	Examples of Diode Marking Methods	5-3
3-4.	In-Circuit Measurements	3-4	5-3.	Front Panel Troubleshooting Setup	5-27
4-1.	Simplified Overall Block Diagram	4-2	7-1.	Explanations of General Information on Schematic Diagrams	7-1

LIST OF ILLUSTRATIONS (Contd)

Number	Title	Page	Number	Title	Page
7-2.	Schematic Diagram Notes	7-2	7-11(a).	Phase Meter (Circuit Description) . .	7-11
7-3.	Component Identification, Top View	7-3	7-11(b).	Schematic Diagram. Phase Meter	7-11
7-4.	Functional Block Diagram	7-3	7-12.	Amplitude Range Switch Component Location	7-12
7-5(a).	Probe Housing Assembly	7-4	7-13(a).	Voltmeter (Circuit Description) . . .	7-13
7-5(b).	Probe Board Assembly	7-4	7-13(b).	Schematic Diagram. Voltmeter . . .	7-13
7-6(a).	RF Sampling Section (Circuit Description)	7-5	7-14.	Search Section Output Waveform . . .	7-14
7-6(b).	Schematic Diagram. RF Sampling Section	7-5	7-15(a).	Automatic Phase Control Section (Part 1) (Circuit Description) . . .	7-15
7-7(a).	IF Section Limiters. (Circuit Description)	7-7	7-15(b).	Schematic Diagram. Automatic Phase Control Section (Part 1) . . .	7-15
7-7(b).	Schematic Diagram. IF Section Limiters	7-7	7-16.	Frequency Range Switch Component Location	7-16
7-8(a).	IF Section Phase Shifters (Circuit Description)	7-9	7-17(a).	Automatic Phase Control Section (Part 2) Sampling Pulse Generator (Circuit Description)	7-17
7-8(b).	Schematic Diagram. IF Section Phase Shifters	7-9	7-17(b).	Schematic Diagram. Automatic Phase Control Section (Part 2) Sampling Pulse Generator	7-17
7-9.	Phase-Range Switch Component Location	7-10	7-18(a).	Power Supplies (Circuit Description) .	7-19
7-10.	Phase Offset Switch Component Location	7-10	7-18(b).	Schematic Diagram. Power Supplies .	7-19

LIST OF TABLES

Number	Title	Page	Number	Title	Page
1-1.	Specifications	1-1	5-4.	Front Panel Troubleshooting.	5-27
5-1A.	Out-of-Circuit Transistor Resistance Measurements	5-2	5-5.	+20 Volt Supply Troubleshooting . . .	5-28
5-1B.	Safe Resistance Ranges for Common Ohmmeters	5-2	5-6.	-20 Volt Supply Troubleshooting . . .	5-29
5-1C.	Etched Circuit Soldering Equipment. .	5-4	5-7.	Phase Meter Circuit Troubleshooting .	5-30
5-1.	Recommended Test Equipment	5-5	5-8.	Channel A and APC Troubleshooting .	5-32
5-2.	Performance Tests	5-8	5-9.	Channel B Circuit Troubleshooting . .	5-33
5-3.	Adjustment Procedure.	5-14	6-1.	Reference Designation Index	6-2
			6-2.	Replaceable Parts	6-28
			6-3.	Code List of Manufacturers	6-35

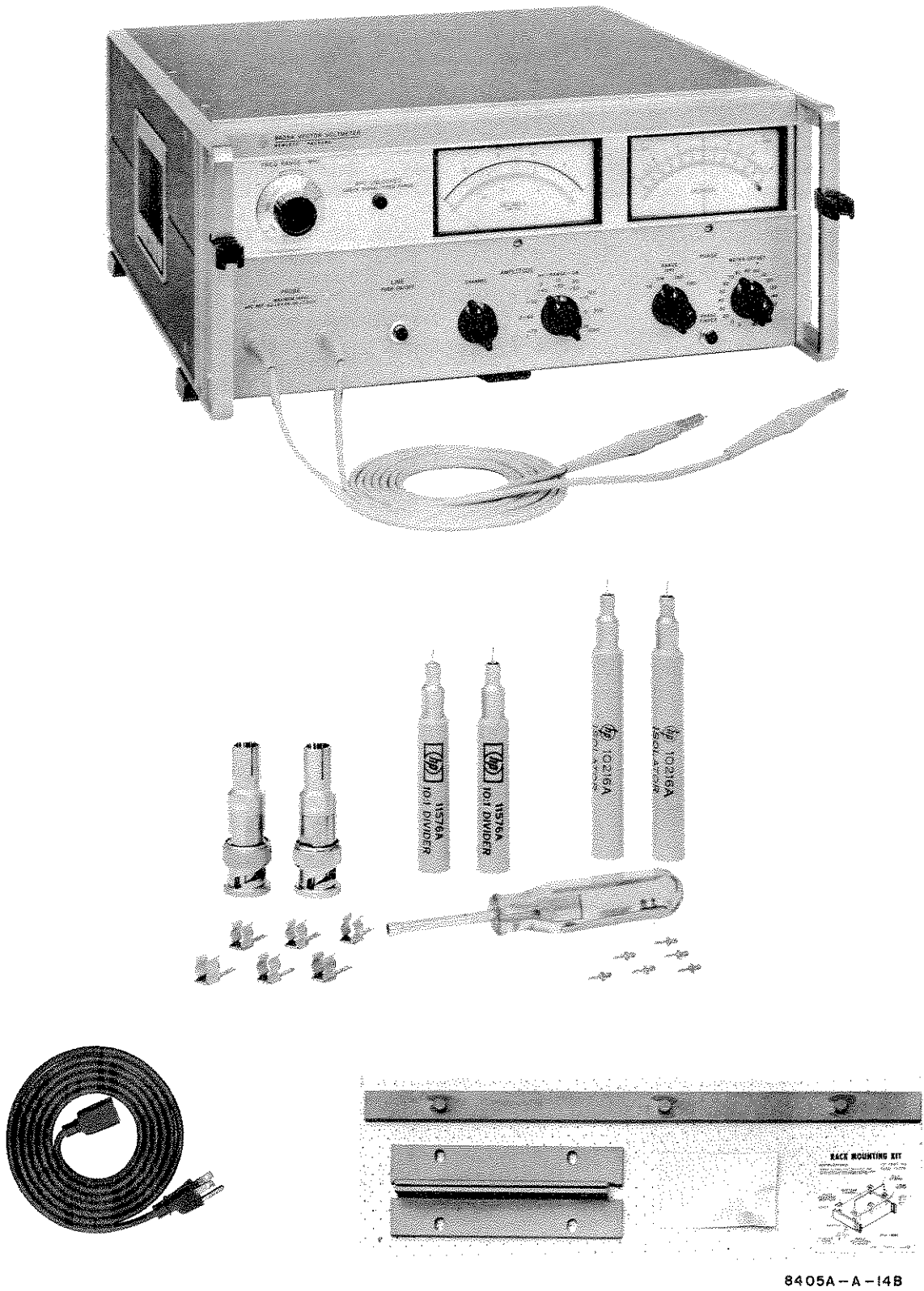

8405A - A - 14B

Figure 1-1. Model 8405A Vector Voltmeter and Supplied Accessories

SECTION I GENERAL INFORMATION

1-1. DESCRIPTION.

1-2. The Model 8405A Vector Voltmeter (Figure 1-1) has a voltmeter and phasemeter for measuring the amplitude and phase relationship of the fundamental components of two RF voltages. The RF range is 1 to 1000 MHz; the phase range is 0 to 360 degrees; and the amplitude ranges are from at least 1.5 millivolts to 1 volt rms for one channel, and 10 microvolts to 1 volt rms for the other.

1-3. Phase relationship is continuously displayed. Angles from 0 to 360° can be measured and read directly from the zero-center meter with ±0.1° resolution.

1-4. Absolute voltage amplitudes read separately can be measured to within ±2% from 1 to 100 MHz, ±6% from 100 to 400 MHz and ±12% from 400 to 1000 MHz. Relative voltage measurements can be made to within ±2% (0.2 dB) of full scale on the -10 through -60 dB Amplitude Ranges.

1-5. Outputs include an intermediate frequency (IF) output for each input, a voltage proportional to amplitude meter voltage reading and a voltage proportional to phase meter reading. The IF outputs are 20 kHz replicas of the RF input waveforms with the same amplitude and phase relationship. Complete specifications of the Model 8405A are given in Table 1-1.

Table 1-1. Specifications



INPUT CHARACTERISTICS	Accessory	Impedance	Frequency	Accuracy*
<p><u>Instrument Type:</u> Two-channel sampling RF millivoltmeter-phasemeter which measures voltage of two signals and simultaneously displays the phase angle between the two signals.</p> <p><u>Frequency Range:</u> 1 MHz to 1 GHz in 21 overlapping octave bands (lowest band covers two octaves).</p> <p><u>Tuning:</u> Automatic within each band. Automatic phase control (APC) circuit responds to the Channel A input signal. Search and lock time, approximately 10 millise.</p> <p><u>Voltage Range</u> Channel A: 1 to 10 MHz: 1.5 mV to 1 V rms. 10 to 500 MHz: 300 μV to 1 V rms. 500 to 1000 MHz: 500 μV to 1 V rms. Can be extended by a factor of 10 with 11576A 10:1 Divider. Channel B: 100 μV to 1 V rms full scale (input to Channel A required); can be extended by a factor of 10 with 11576A 10:1 Divider.</p> <p><u>Input Impedance (nominal):</u> 0.1 megohm shunted by approximately 2.5 pF; 1 megohm shunted by approximately 2 pF when 11576A 10:1 Divider is used; 0.1 megohm shunted by approximately 5 pF when 10216A Isolator is used. AC coupled.</p> <p><u>Isolation Between Channels:</u> 1 to 300 MHz: greater than 100 dB. 300 to 1000 MHz: greater than 80 dB.</p> <p><u>Maximum AC Input:</u> 2 V peak. <u>Maximum DC Input:</u> ±50 V.</p>	HP 11536A 50Ω Feed-through Tee	50 Ω		1-100 MHz ±2% of full scale
		Freq.	SWR	100-300 MHz ±6% of full scale
		1-750 MHz 1-1000 MHz	< 1.15 < 1.20	300-1000 MHz ±12% ** of full scale
	HP 11576A 10:1 Divider	$1\text{ M}\Omega$ equiv.  2 pF to $Z = \frac{80}{f(\text{MHz})}$ kΩ from 5-100 MHz		1-100 MHz ±6% of full scale
		HP 10216A Isolator	$100\text{ k}\Omega$ equiv.  5 pF to $Z = \frac{32}{f(\text{MHz})}$ kΩ	
* After one-hour warmup. ** Above 300 mV and 800 MHz add +5%.				
<p><u>VOLTMETER CHARACTERISTICS</u></p> <p><u>Meter Ranges:</u> 100 μV to 1 V rms full scale in 10-dB steps. Meter indicates amplitude of the input signal.</p> <p><u>Voltage Accuracy:</u> When accessories are used on one or both probes.</p>				
<p><u>Voltage Ratio Accuracy:</u> 1-200 MHz. 0.2 dB for -60 to 0 dB Ranges. 0.5 dB for -70 dB and +10 dB Ranges.</p> <p><u>Voltage Ratio Accuracy:</u> 200-1000 MHz. 0.2 dB for -60 to -10 dB Ranges. 0.5 dB for -70 dB and 0 dB Ranges. 1.5 dB for +10 dB Range.</p> <p><u>Residual Noise:</u> Less than 10 μV as indicated on the meter.</p> <p><u>Bandwidth:</u> 1 kHz.</p>				

Table 1-1. Specifications (cont'd)

PHASEMETER CHARACTERISTICS

Phase Range: 360°, indicated on zero-center meter with end-scale ranges of ±180, ±18, and ±6°. Meter indicates phase difference between the fundamental components of the input signals.

Resolution: 0.1° at any phase angle.

Meter Offset: ±180° in 10° steps.

Phase Accuracy: At single frequency 1.5° (equal voltage at Channel A and B).

Phase Accuracy vs. Voltage: See table below.

Phase Jitter vs. Channel B Input Level:

Greater than 700 μV: Typically less than 0.1° p-p.

125 to 700 μV: Typically less than 0.5° p-p.

20 to 125 μV: Typically less than 2° p-p.

Phase: 0 to ±0.5 Vdc ±6%, proportional to phase-meter reading. External load greater than 10,000 ohms affects recorder output and meter reading less than 1%. Output tracks meter reading within ±1.5% end scale; BNC female connector.

RFI: Conducted and radiated leakage limits are below those specified in MIL-I-6181D and MIL-I-16910C except for pulses emitted from probes. Spectral intensity of these pulses is approximately 60 μV/MHz; spectrum extends to approximately 2 GHz. Pulse rate varies from .98 to 2 MHz.

Option 02. Linear dB scale uppermost on voltmeter.

Power: 115 or 230 V ±10%, 50 to 400 Hz, 35 watts.

Weight: Net, 30 lbs (13, 5 kg).

GENERAL

20 kHz IF Output (each channel): Reconstructed signals, with 20 kHz fundamental components, having the same amplitude, waveform, and phase relationship as the input signals. Output impedance, 1000 ohms in series with 2000 pF; BNC female connectors.

Recorder Output:

Amplitude: 0 to +1 Vdc ±6% open circuit, proportional to voltmeter reading in volts. Output tracks meter reading within ±0.5% of full scale. Output impedance, 1000 ohms; BNC female connector.

Dimensions:

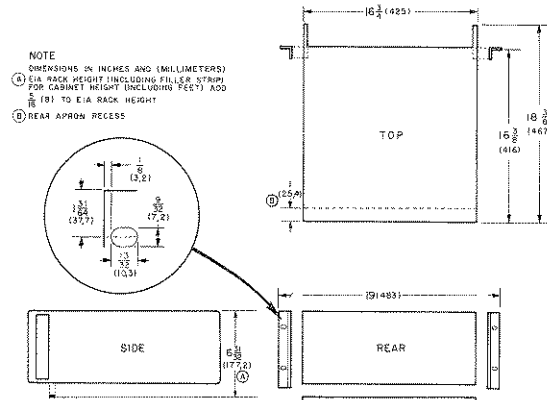

Phase Accuracy Vs. Voltage

Accessory	Frequency (MHz)	Voltage Range Channel A	Voltage Range Channel B	Phase* Accuracy
HP 11536A	1 - 10	1.5 mV to 300 mV	100 μV to 300 mV	±3°
50-Ohm Feed-through Tee	10 - 500	300 μV to 300 mV	100 μV to 300 mV	±3°
	500 - 1000	500 μV to 100 mV	100 μV to 100 mV	±3°
HP 11576A	1 - 10	1.5 mV to 3V	1 mV to 3V	±4°
10:1 Divider	10 - 100	1 mV to 3V	1 mV to 3V	±4°
HP 10216A	1 - 10	1.5 mV to 300 mV	100 μV to 300 mV	±6°
Isolator	10 - 200	300 μV to 300 mV	100 μV to 300 mV	±6°

*To be added to single-frequency accuracy (±1.5°) when the voltages at Channel A and B are not equal.

1-6. ACCESSORIES FURNISHED.

1-7. A detachable power cable, a rack-mounting kit with mounting hardware and several probe accessories are supplied with the Model 8405A. The probe accessories consist of two isolators, two voltage dividers, grounding clips, replacement probe tips and wrench, and probe to BNC adapters.

1-8. ISOLATOR. The HP 10216A Isolators attach to the input probes and eliminate the effect of test point impedance.

1-9. DIVIDER. The HP 11576A 10:1 voltage dividers attach to the input probes to increase the maximum input voltage limit to 10 volts rms. The dividers also eliminate the effect of test point impedance.

1-10. GROUNDING CLIPS. The grounding clips fasten to the dividers and isolators near the probe tip for grounding close to the measuring point.

1-11. PROBE TIPS. The probe tips are screw-in replacements for the probe points.

1-12. PROBE-TO-BNC ADAPTER. The HP 10218A adapter converts the probe tip to a male BNC connector.

1-13. ACCESSORIES AVAILABLE.

1-14. PROBE-TO-MICRODOT ADAPTER. Two versions are available: one converts the probe tip to a Microdot screw-on connector, the other converts the tip to a Microdot push-on connector. The adapters are available under accessory numbers 10220A (screw-on version) and 10223A (push-on style).

1-15. FIFTY OHM TEE. This connector is specially designed to match the impedance of the Model 8405 probe to permit monitoring signals in a 50-ohm transmission line. The line section has type N connectors and probe coupling is by means of a push-style friction connector. The tee is available under accessory number 11536A.

1-16. ACCESSORY CASE. The accessory case, with two compartmented sections, provides convenient storage for accessories and is available under accessory number 11570-60001.

1-17. ACCESSORY KIT. A kit of accessories and adapters is available under accessory number 11570A. The kit contents are listed in the following table.

Qty.	Description	HP Part Number
2	50-ohm tee, type N to probe	11536A
1	Power splitter, type N	11549A
2	50-ohm termination, type N	908A
1	Shorting plug, type N	11512A
1	Accessory Case	11570-60001

1-18. The items listed as part of the Accessory Kit are also available separately. Order by the HP part number given in the Table.

1-19. INSTRUMENT COVERED BY MANUAL.

1-20. This manual applies directly to instruments having serial numbers prefixed 838 (first three numbers of serial number). If the serial prefix of your instrument is other than 838, there are differences between the instrument described in this manual and your instrument. These differences are described in the appendix at the rear of this manual or in a Manual Changes sheet supplied with this manual. If the manual changes sheet is missing, the information can be supplied by your nearest Hewlett-Packard Sales and Service Office (see lists at the rear of this manual). The manual changes sheet may also include an "ERRATA" section which describes manual correction information which applies to the manual for all instruments INCLUDING instruments prefixed 838.

1-21. INSTRUMENT OPTIONS.

1-22. OPTION 02. Model 8405A furnished with the normally installed AMPLITUDE meter replaced with a special logarithmic meter. This special meter has a linear dB scale which is uppermost on meter face. Meter scale is about 12 dB with a calibrated accuracy of ± 0.2 dB.

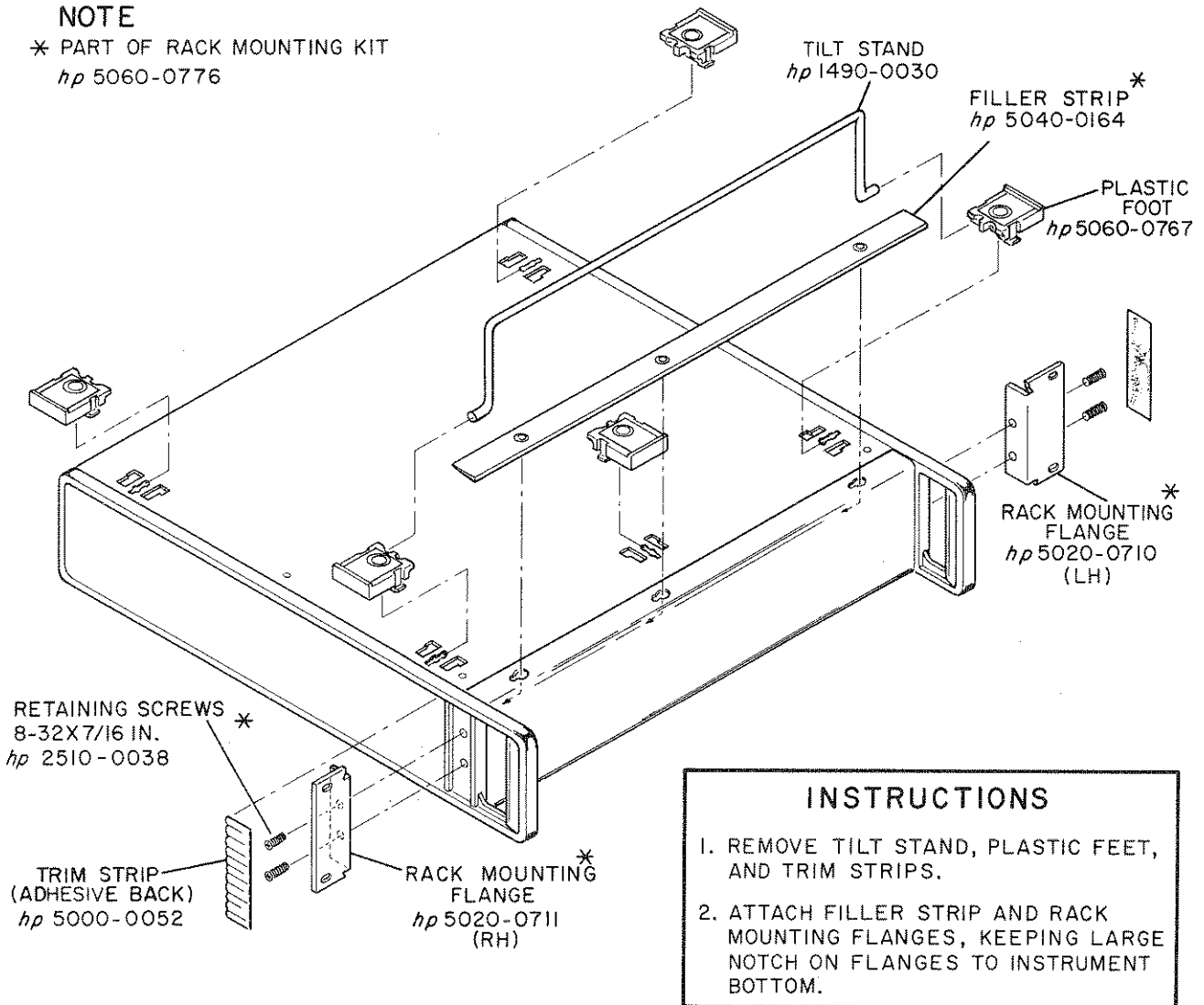

Figure 2-1. Preparation for Rack Mounting

SECTION II

INSTALLATION

2-1. UNPACKING AND INSPECTION.

2-2. The Vector Voltmeter was carefully inspected, mechanically and electrically, prior to shipment. Inspect it for mechanical damage incurred in transit, check for supplied accessories, and test electrical performance. If there is damage or deficiency notify the carrier and the nearest Hewlett-Packard office (HP offices are listed at the rear of this manual). In the event of mechanical damage, the packing materials and carton should be held for carrier's inspection.

2-3. PREPARATION FOR USE.

2-4. POWER REQUIREMENTS.

2-5. The Vector Voltmeter requires a power source of 115 or 230 volts ac $\pm 10\%$, 50 to 400 Hz, single phase, which can supply approximately 35 watts.

2-6. 115/230 VOLT OPERATION.

2-7. A rear panel two-position slide switch permits operation from either a 115- or 230-volt power source. The number visible on the switch indicates line voltage for which the instrument is connected. Adjacent to switch is correct line fuse rating for each line voltage.

2-8. To prepare the Model 8405A for operation, position the 115-230 volt switch so that the number visible on the slider corresponds to the available line voltage, and install a line fuse of correct rating.

CAUTION

To avoid damage to the instrument, before connecting the power cable, set the 115-230 switch for the line voltage to be used.

2-9. POWER CABLE.

2-10. To protect operating personnel, the National Electrical Manufacturers' Association (NEMA) recommends that instrument panels and cabinets be grounded. Accordingly, the Vector Voltmeter is equipped with a three-conductor power cable which, when plugged into an appropriate receptacle, ground panel and cabinet. The offset pin of the three-prong connector is the ground pin.

2-11. To preserve the protection feature when operating the Vector Voltmeter from a two-contact outlet, use a three-prong to two-prong adapter (HP Stock No. 1251-0048) and connect the green pigtail on the adapter to ground.

2-12. COOLING.

2-13. The temperature of surrounding air must not exceed 55°C (131°F). Clearances for ventilation should

be 3 to 4 inches at the rear of the cabinet and 2 to 3 inches at the sides. The clearances provided by the plastic feet in bench stacking and the filler strips in rack mounting are adequate for the top and bottom cabinet surfaces.

2-14. BENCH OPERATION.

2-15. The Model 8405A cabinet has plastic feet and a foldaway tilt stand for convenience in bench operation. The tilt stand permits inclining the instrument for ease in reading the meters. The plastic feet are shaped to provide clearance for air circulation and to make full-width modular cabinet instruments such as the Vector Voltmeter self-aligning when stacked.

2-16. RACK MOUNTING.

2-17. Preparation for rack mounting is illustrated in Figure 2-1. All necessary hardware is included in the supplied rack mounting kit.

2-18. REPACKAGING FOR SHIPMENT.

2-19. USING ORIGINAL PACKAGING. The same containers and materials used in factory packaging can be obtained through the Hewlett-Packard sales and service offices listed at the rear of this manual.

2-20. If the Model 8405A is being returned to Hewlett-Packard for servicing attach a tag indicating the type of service required, return address, model number and full serial number. Also, mark the container FRAGILE to assure careful handling.

2-21. In any correspondence refer to the instrument by model number and full serial number.

2-22. USING OTHER PACKAGING. The following general instructions should be used for repackaging with commercially-available materials:

a. Wrap the instrument in heavy paper or plastic. (If shipping to a Hewlett-Packard service office or center, attach a tag indicating the type of service required, return address, model number, and full serial number.)

b. Use a strong shipping container. A double-wall carton made of 350 pound test material is adequate.

c. Use enough shock-absorbing material (3 to 4 inch layer) around all sides of the instrument to provide firm cushion and prevent movement inside the container. Protect the control panel with cardboard.

d. Seal the shipping container securely.

e. Mark the shipping container FRAGILE to assure careful handling.

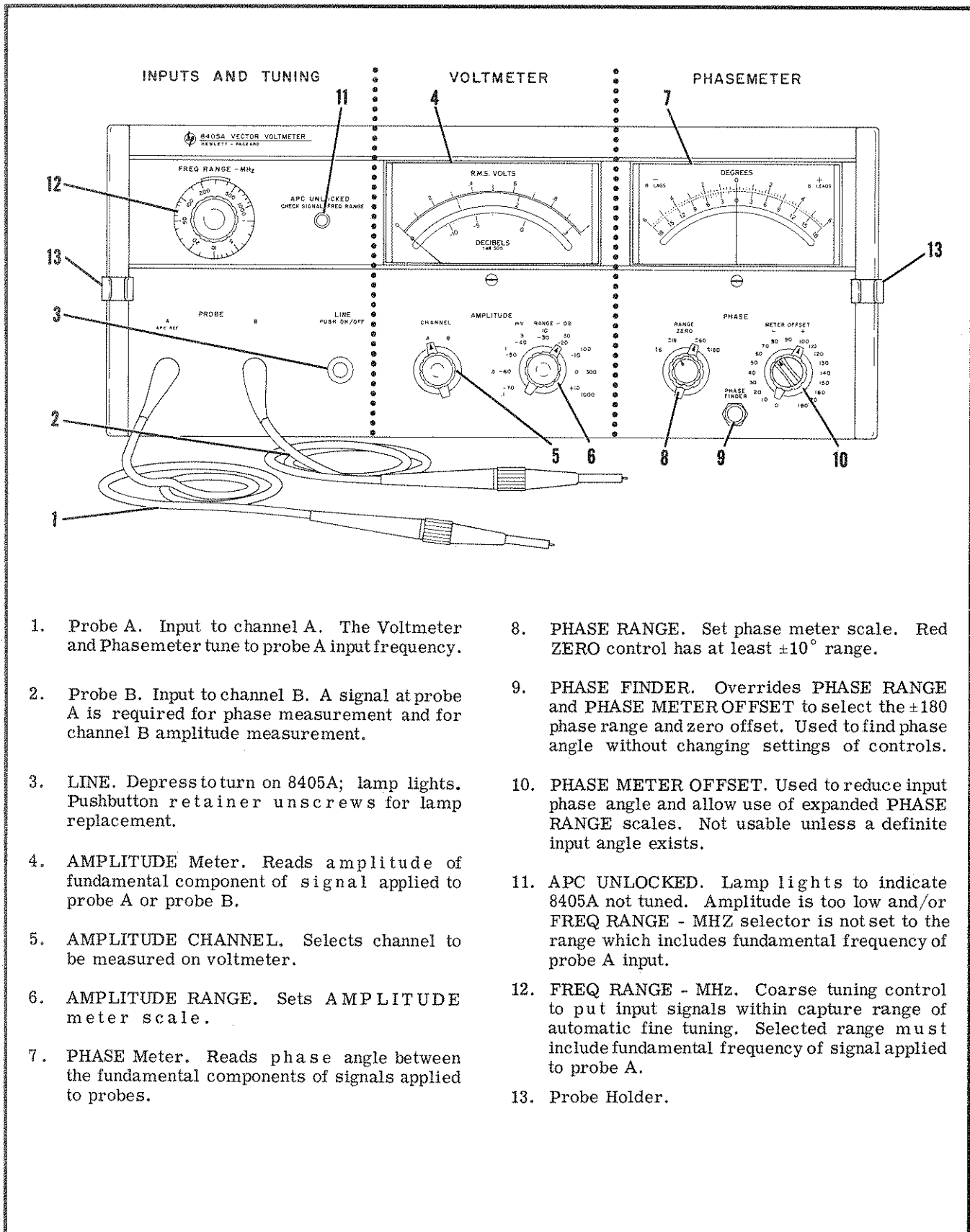

1. Probe A. Input to channel A. The Voltmeter and Phasemeter tune to probe A input frequency.
2. Probe B. Input to channel B. A signal at probe A is required for phase measurement and for channel B amplitude measurement.
3. LINE. Depress to turn on 8405A; lamp lights. Pushbutton retainer unscrews for lamp replacement.
4. AMPLITUDE Meter. Reads amplitude of fundamental component of signal applied to probe A or probe B.
5. AMPLITUDE CHANNEL. Selects channel to be measured on voltmeter.
6. AMPLITUDE RANGE. Sets AMPLITUDE meter scale.
7. PHASE Meter. Reads phase angle between the fundamental components of signals applied to probes.
8. PHASE RANGE. Set phase meter scale. Red ZERO control has at least $\pm 10^\circ$ range.
9. PHASE FINDER. Overrides PHASE RANGE and PHASE METER OFFSET to select the ± 180 phase range and zero offset. Used to find phase angle without changing settings of controls.
10. PHASE METER OFFSET. Used to reduce input phase angle and allow use of expanded PHASE RANGE scales. Not usable unless a definite input angle exists.
11. APC UNLOCKED. Lamp lights to indicate 8405A not tuned. Amplitude is too low and/or FREQ RANGE - MHZ selector is not set to the range which includes fundamental frequency of probe A input.
12. FREQ RANGE - MHZ. Coarse tuning control to put input signals within capture range of automatic fine tuning. Selected range must include fundamental frequency of signal applied to probe A.
13. Probe Holder.

Figure 3-1. Front Panel Features

SECTION III

OPERATING INSTRUCTIONS

3-1. INTRODUCTION.

3-2. The Model 8405A Vector Voltmeter is a direct-reading, two-channel, tuned millivoltmeter-phase-meter for measuring the amplitudes of and phase angle between the fundamental components of two radio frequency voltages. The radio frequency range is 1 to 1000 MHz, the phase range is 360 degrees, and the amplitude ranges are from at least 1.5 millivolts to 1 volt rms for reference channel A and from 100 microvolts to 1 volt rms for channel B. Supplied dividers extend the upper limit of the amplitude ranges.

3-3. The Vector Voltmeter consists of a phase-meter and ac voltmeter which have common inputs and tuning. The phasemeter continuously monitors the inputs while the Voltmeter is switched manually to read channel A or channel B.

3-4. APPLICATIONS.

3-5. Information regarding specific system and measurement usage is provided in the Hewlett-Packard Journal Vol. 17, No. 9, and a series of HP Application Notes numbered 77. Copies of this literature are available from your local sales and service office upon request (see offices listed at the rear of this manual).

3-6. PANEL FEATURES.

3-7. Front and rear panel features are described in Figures 3-1 and 3-2. Description numbers match the numbers on the illustration.

3-8. OPERATING PROCEDURES.

3-9. Figures 3-3 and 3-4 give step-by-step operating procedures. The steps of each procedure are numbered, and the illustration is numbered to correspond.

3-10. GENERAL OPERATING AND MEASUREMENT CONSIDERATIONS.

3-11. INITIAL TURN-ON.

- a. Set rear-panel LINE switch to match line voltage.
- b. Check line fuse for rating beside number showing on LINE switch (1 amp 3AG for 115 Vac; 1/2 amp slo-blo 250V for 230 Vac).
- c. Connect power cable to line voltage.
- d. Press LINE button. The line button should glow indicating line power applied to instrument.

3-12. INPUT PROBES.

3-13. MECHANICAL FEATURES.

- a. Identifying rings: channel A, blue ring; channel B, white ring.

- b. Metal parts: Since probes attach to accessory adapters by push-on friction couplings, metal parts must be clean and free of defects (i.e., burrs and gouges). Also, pointed tips must be aligned with long axis of probe so that tips are not broken when inserted in adapters.

- c. Storage and shipment: to protect probes, adapters such as the probe-to-BNC adapter should be left on when not in use.

- d. Tip replacement: Tips are removed by turning counterclockwise (use supplied accessory - HP Part No. 8710-0084, Nut Driver). Replacement tips should not be tightened excessively. Additional tips are available under HP Part No. 5020-0457.

3-14. ELECTRICAL FEATURES.

- a. Probe burn-out: Maximum input is 1.4 volts rms and 2 volts peak; and ± 50 Vdc to avoid probe burn-out.

- b. Interaction between channels: Do not connect both probes directly to same test point. For common connection, both probes can be fitted with Isolators (HP 10216A) or 10:1 Dividers (HP 11576A).

- c. Sensitivity: Minimum input to probe A is 1.5 mV, 1-10 MHz; 300 μ V, 10-500 MHz; and 500 μ V, 500-1000 MHz. For probe B minimum input is 10 μ V for entire range (1-1000 MHz).

3-15. INPUT SIGNALS.

3-16. Phase and amplitude measurements can be made at any frequency between 1 and 1000 MHz. However, the Vector Voltmeter is frequency selective and therefore must be tuned to input signals. Tuning is semi-automatic with manual coarse tuning and automatic fine tuning. The automatic function tunes both channels simultaneously to the channel A signal. Thus, channel A signal determines the frequency at which measurements are made.

3-17. A condition for tuning is that channel A be large enough to trigger tuning. Minimum required channel A amplitude is frequency dependent as follows: 1.5 mV for 1-10 MHz, 300 μ V for 10-500 MHz, and 500 μ V for 500-1000 MHz.

3-18. The Vector Voltmeter is a tuned device with a very narrow passband (± 1 kHz) at the measurement frequency. Therefore, measurements can be made on complex waveforms, and amplitude-modulated signals as well as sinusoidal signals. Pulse modulated signals, however, cannot be measured as the 8405A cannot tune to an intermittent signal.

NOTE

With complex waveforms the 8405A tunes to the frequency of the component having the greatest amplitude in the tuning range selected.

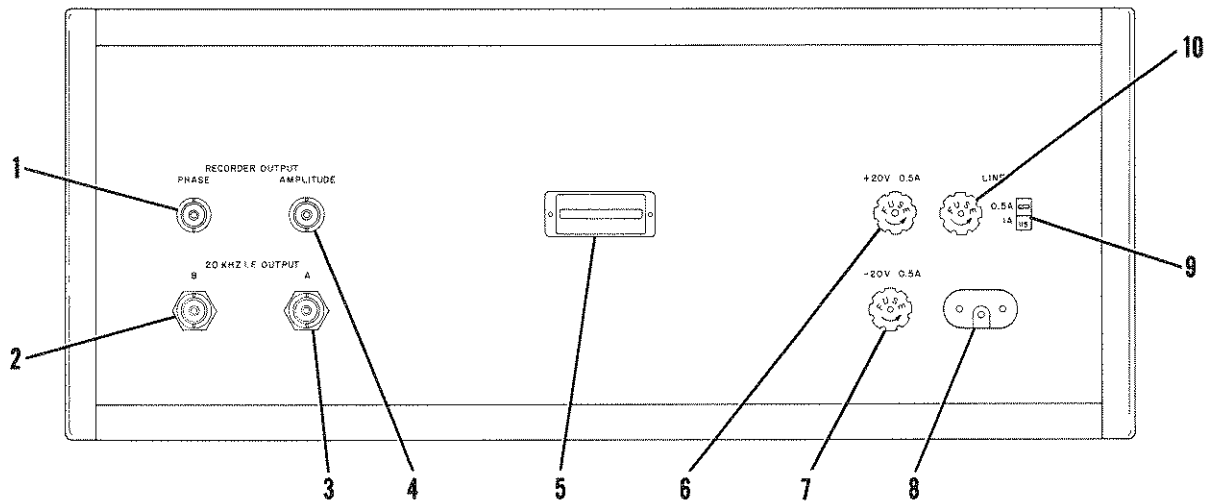

1. PHASE RECORDER OUTPUT. DC voltage proportional to phase meter reading. Zero volts corresponds to zero phase reading, +0.5 Vdc open circuit corresponds to full scale positive phase reading, -0.5 Vdc corresponds to full scale negative phase reading regardless of phase range.
2. 20 KHZ I. F. OUTPUT B. IF replica of channel B RF waveform. Amplitude is the same as the RF waveform, but the fundamental frequency is always 20 kHz.
3. 20 KHZ I. F. OUTPUT A. IF replica of channel A RF waveform. Amplitude is the same as the RF waveform, but fundamental frequency is always 20 kHz. IF signals A and B have the same phase relationship as the RF signals.
4. AMPLITUDE RECORDER OUTPUT. DC voltage output proportional to voltage reading. Zero corresponds to zero volts, +1 Vdc open circuit corresponds to full scale reading regardless of amplitude range selected.
5. Identification Plate.
6. +20V Fuseholder. Fuse is overcurrent protection for the internal +20 Vdc power supply.
7. -20V Fuseholder. Fuse is overcurrent protection for the internal -20 Vdc power supply.
8. Power Cable Connector.
9. LINE Voltage Switch. Permits operation from 115 or 230 volt ac line. Number visible on slider is operating voltage. Adjacent number on panel is correct line fuse rating.
10. LINE Fuseholder. Fuse should have rating adjacent to number visible on line switch slider.

Figure 3-2. Rear Panel Features

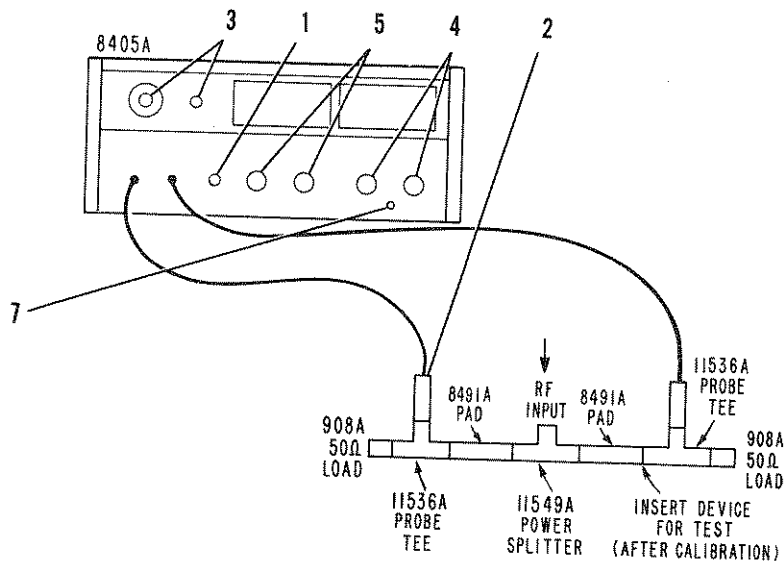

CAUTION

Do NOT burn out probes. Maximum input: ± 50 volts dc or 2 volts peak (4 volts pp). Potential changes between test points should not exceed 50 volts dc to avoid transient pulses. Transient pulses greater than 50 V will burn out the probe. For this reason a blocking capacitor cannot be used in series with the probe to measure ac in a circuit with a dc potential of greater than 50 V.

1. Connect equipment for calibration as shown above. Push LINE switch. Pushbutton should glow.
2. Apply signal to RF INPUT. Set AMPLITUDE CHANNEL to A.
3. Set FREQ. RANGE-MHz to include measurement frequency. APC UNLOCKED light should go out showing that 8405A is tuned. NOTE: Channel A input must be at least 1.5 mV (1-10 MHz); 300 μ V (10-500 MHz); or 500 μ V (500-1000 MHz). (If input frequency is changed within FREQ RANGE selected, APC UNLOCKED may flash every 1.6 MHz. This is normal, 8405A is retuning.)
4. Set PHASE RANGE to ± 180 , PHASE METER OFFSET to 0, and adjust PHASE ZERO for zero phase meter reading. Switch RANGE to ± 6 and re-zero as necessary.
5. Set AMPLITUDE CHANNEL to B and AMPLITUDE RANGE to obtain on-scale voltmeter reading. Record reading.
6. Insert device under test into circuit as shown above. Set AMPLITUDE RANGE to obtain on-scale voltmeter reading. Residual attenuation or gain of device is difference between recorded reading of step 5 and voltmeter reading.
7. Noting the PHASE Meter, push PHASE FINDER button. If meter needle goes to left (-) set METER OFFSET (red knob) to -; if to right (+) set METER OFFSET to +. Adjust METER OFFSET (black knob) for on-scale reading. To obtain phase reading, add meter reading and offset switch setting. For example, if offset setting is +50, meter reading is -4 and RANGE is ± 6 , then the actual angle is $+46^\circ$.

Figure 3-3. Transmission Line Measurements

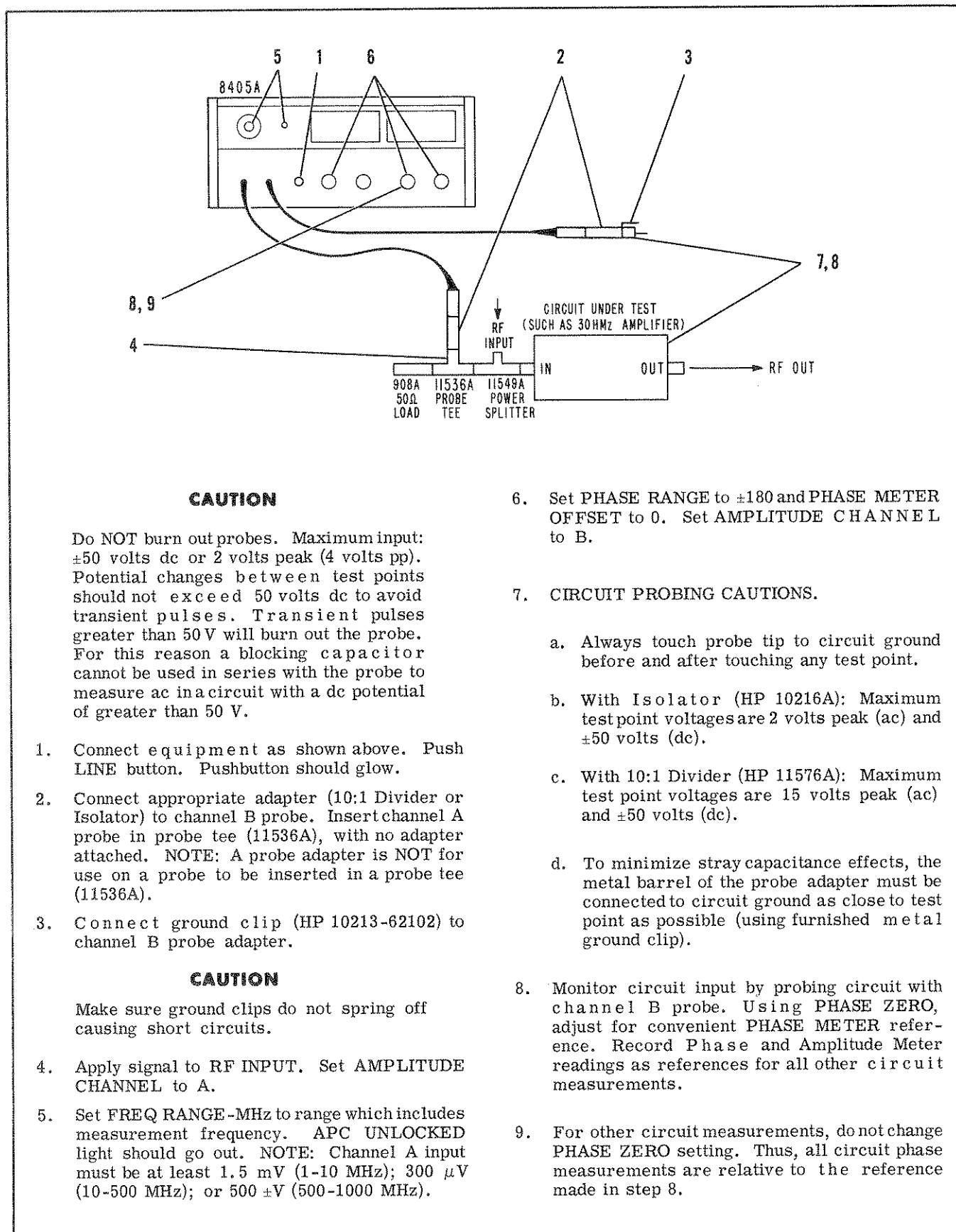

Figure 3-4. In-Circuit Measurements

3-19. For amplitude measurement of one signal, the signal must be applied to probe A. If the sensitivity of channel B is needed, a signal at the measurement frequency must be applied to channel A for 8405A tuning and the signal to be measured can be applied to channel B probe.

3-20. IN-CIRCUIT MEASUREMENTS.

3-21. PROBING IN CIRCUITS. The main considerations for measurements made by probing in circuits are the effects of the input impedance of the probe, the impedance of the circuit at the point of measurement, the injection of sampling signal by the probe, and the method of grounding the probe.

3-22. CIRCUIT LOADING.

3-23. Probe input impedance at the measurement frequency can load the circuit under test in a way that alters its performance and so produces erroneous readings. The input impedance of a probe is 0.1 megohm shunted by 2.5 picofarads. With 10:1 divider (HP 11576A) attached input impedance increases to 1 megohm shunted by 2 picofarads. However, use of a divider reduces amplitude sensitivity by a factor of 10, increases amplitude measurement error, and adds phase error when used on one probe only.

3-24. CIRCUIT IMPEDANCE.

3-25. Variations in test point impedance from point to point influence the probes and can cause measurement errors. For instance, amplitude measurement error can be +0 to -2% with a test point impedance of 25 to 1000 ohms. Phase measurement error will be less than $\pm 2^\circ$ for test point impedance variations of from 0 to 50 ohms, and less than -9° for test point impedance variations of from 25 to 1000 ohms. These errors can be eliminated by the 10:1 divider or isolator probe accessories which are particularly effective in fixed-frequency measurements where their own frequency-dependent error effects are not a consideration.

3-26. SAMPLING SIGNAL.

3-27. The signal from the probes is the same one that down-converts the input frequency to the frequency at which measurements are made. The signal consists of pulses 0.3 nanoseconds wide with a repetition rate between 0.98 and 2 MHz and amplitude determined by the bandwidth and impedance of the circuit under test. The actual pulse rate depends upon the frequency of the signal applied to probe A, but is stable at any given frequency. Into a 50-ohm impedance, pulse amplitude is approximately 60 microvolts per megahertz of circuit bandwidth to a maximum of about 2000 MHz. To prevent these signals from reaching and affecting the circuit-under-test, the 10:1 divider probe adapters should be used.

3-28. PROBE GROUNDING.

3-29. The metal barrel at the tip of the probe or accessory if used should be connected to the ground of the circuit under test as close to the test point as possible. The supplied metal clips are for grounding the isolator and divider accessories. The standard probe does not require grounding.

CAUTION

Make sure ground clips do not spring off causing short circuit. Do NOT attempt to use these ground clips with the standard probes.

3-30. COAXIAL MEASUREMENTS.

3-31. For measurements in transmission lines the prime considerations are the discontinuities due to the probes and the signal injected by the probes. For monitoring signals in 50-ohm lines, the Model 11536A Tee is convenient. The signals from the probes are described in Paragraph 3-26.

3-32. SWEEP-FREQUENCY OPERATION.

3-33. Continuous phase and amplitude measurements can be made on signals which change frequency with time provided that the rate of change does not exceed 15 MHz/second and that the frequency remains within the automatic fine tuning range. As the input frequency changes APC UNLOCKED flashes momentarily about every 1.6 MHz. This is a normal occurrence and does not produce any measurement uncertainty. Fixed frequency measurements at these frequencies have the same accuracy as measurements at any other frequency. Best operation is achieved sweeping down in frequency.

3-34. ZERO-SETTING THE PHASEMETER.

3-35. Use accessory isolators or dividers to prevent interaction between the probes. For in-circuit measurements (Figure 3-4) zero phase indication is obtained by placing the probes at the same point and adjusting PHASE ZERO.

3-36. For measurements in 50-ohm transmission lines, to make zero adjustment independent of frequency an arrangement such as that shown in Figure 3-3 can be used. This arrangement is typical of what might be used for a phase, residual attenuation or gain measurement. If the electrical path lengths between signal source and probe are equal, a zero adjustment is unaffected by change of input frequency. Although standard components may be used to assemble the two path arrangement, like components should be by the same maker and coupling should be done carefully. Small differences in the electrical lengths of the branches do not significantly affect zero accuracy at test frequencies below 500 MHz. For measurements above 500 MHz length differences can be detected by interchanging the probes after initial zeroing. Any change in phase reading indicates the branches do not have equal electrical length. This

condition can be corrected by component substitution or it can be compensated for in the zero adjustment. The purpose of the pads in Figure 3-3 is to reduce measurement errors caused by mismatch between the type N and probe tees.

3-37. 20 kHz IF OUTPUTS.

3-38. The rear-panel 20 kHz IF outputs A and B are replicas of the RF signals applied to probes A and B. The IF signals have the same waveform, amplitude (up to 1 volt rms), and phase relationship as the RF signals, but the fundamental frequency of the IF signal is always 20 kHz and the harmonics of the RF signal are corresponding harmonics of 20 kHz. Up to approximately the twelfth harmonic of the RF fundamental can be reproduced in the IF signal, provided that the twelfth harmonic of the RF signal is within the frequency range of the Vector Voltmeter.

3-39. The IF signal is obtained by a sampling process; therefore, the wave displayed by an oscilloscope consists of narrow, shallow steps which closely duplicate the RF waveform. The IF outputs can be used to display RF waveforms with low frequency oscilloscopes and to make distortion measurements of RF signals with low frequency wave analyzers.

3-40. USE OF SUPPLIED PROBE ACCESSORIES.

3-41. MODEL 11576A 10:1 DIVIDER. The 10:1 divider accessories decrease probe input sensitivity. The input impedance of the probe-divider combination is 1 megohm shunted by 2 picofarads. Input sensitivity is decreased by a factor of 10.

3-42. The dividers can be used to measure voltages of increased amplitude, to effectively eliminate measurement errors due to variations in test point impedance, and to reduce the amplitude of the sampling signal from the probe.

NOTE

The 10:1 Divider and/or Isolator adapters are not for use in a Probe Tee, such as the HP 11536A, HP 11576A, or HP 11063A. These adapters are for use: (1) When 8405A probe is connected to a BNC, Type N, or any other common tee; (2) When 8405A probe is used for in-circuit-type measurements.

3-43. MODEL 10216A ISOLATOR. The isolator accessories eliminate the effects of variations in test point impedance on measurement accuracy. An isolator adds no more than 3 picofarads to probe input capacitance.

3-44. In addition to being used to isolate test point impedance from the probes, the isolators can be used to prevent interaction between the probes when they are applied to the same test point.

3-45. GROUNDING CLIPS. The grounding clips are for use with the Divider and Isolator probe accessories. They clip onto the narrower metal barrel just behind the tip, and should be used to connect to circuit ground as near the test point as possible.

3-46. MODEL 10218A BNC ADAPTER. BNC adapter converts probe tip to a conventional BNC male RF connector.

SECTION IV

PRINCIPLES OF OPERATION

4-1. GENERAL.

4-2. The Vector Voltmeter converts two RF signals of the same fundamental frequency in the range from 1 to 1000 MHz to two 20-kHz IF signals. The IF signals retain the same amplitudes, waveforms, and phase relationship. Consequently, the fundamental components of the IF signals have the same amplitude and phase relationships as the fundamental components of the RF signals. The IF signals are filtered and then measured by a voltmeter and a phasemeter.

4-3. SIMPLIFIED BLOCK DIAGRAM DESCRIPTION.

4-4. The Vector Voltmeter, shown simplified in Figure 4-1, consists of a two-channel RF-to-IF converter, an ac voltmeter, and a phasemeter.

4-5. RF-TO-IF CONVERTER. The converter changes two RF signals (V_A and V_B) which have the same fundamental frequency to two IF signals with 20 kHz fundamental frequencies. These IF signals have the same waveforms, amplitudes, and phase relationship (ϕ) as the RF signals. The 20 kHz sinusoidal fundamental components (V_{AF} and V_{BF}) are extracted from the IF signals by narrowband filters. These sinusoids have the same amplitudes and phase relationship as the fundamental components of the RF input signals.

4-6. VOLTMETER. The voltmeter, a conventional ac voltmeter, is switched manually to measure the amplitude of either IF sinusoid.

4-7. PHASEMETER. Before application to the phasemeter the 20 kHz sinusoids are amplified and clipped to remove amplitude difference and retain only the phase difference ϕ . In the phasemeter the clipped sine waves V_C become triggers spaced in time in proportion to the phase difference between sine waves V_{AF} and V_{BF} . The triggers generate a square wave with symmetry proportional to the time between triggers and therefore the phase difference. This square wave controls the current that operates the phase meter. The average meter current is governed by the symmetry of the square wave; therefore, the meter indication is proportional to the phase difference ϕ . Thus the phasemeter measures the phase angle between the fundamental components of the RF input signals.

4-8. RECORDER OUTPUTS. For external monitoring and recording a voltage proportional to the phase meter reading, a voltage proportional to the amplitude meter reading in volts, and IF replicas of the input RF signals are available at separate rear-panel outputs.

4-9. DETAILED BLOCK DIAGRAM DESCRIPTION.

4-10. CIRCUIT SECTIONS.

4-11. Figure 7-4 is a detailed overall block diagram of the Vector Voltmeter which includes the schematic location of circuit sections by page number. As shown in the diagram, there are five main circuit sections: identical channel A and channel B RF-to-IF Converters, an Automatic Phase Control Section, a Phasemeter, and a Voltmeter.

4-12. The RF-to-IF Converters and the Automatic Phase Control section produce two 20 kHz sine waves which have the same amplitudes and phase relationship as the fundamental components of the RF signals applied to channels A and B.

4-13. The Phasemeter section continuously monitors these two 20 kHz sine waves and provides a meter display of the phase angle between them. The Voltmeter section is manually switched to channel A or channel B 20 kHz sine wave and provides a meter display of the amplitude.

4-14. CIRCUIT DESCRIPTIONS.

4-15. Detailed circuit descriptions are given in Figures 7-6 through 7-18 of this manual. The descriptions are in the form of duplicate diagrams with word descriptions in place of circuits or circuit parts. Only those circuit sections which are not fully described on the diagrams are included in this section.

4-16. THE RF-TO-IF CONVERTERS.

4-17. As shown in Figure 4-2, the RF-to-IF converters are the input sections of the Vector Voltmeter. The Converters change any two RF signals of the same fundamental frequency in the range from 1 to 1000 MHz to two 20 kHz sine waves with the same amplitudes and phase relationship as the fundamental components of the RF signals.

4-18. Channel A Converter is the same as channel B Converter. Each Converter consists of a sampler and a tuned amplifier. The sampler produces a 20 kHz waveform replica of the RF input waveform, and the tuned amplifier extracts the 20 kHz fundamental component from this waveform replica.

4-19. SAMPLING.

4-20. As used in the Vector Voltmeter, sampling is a time-stretching process with which a high frequency repetitive signal is duplicated at a much lower frequency. The low frequency signal is obtained by accumulating amplitude samples taken from different

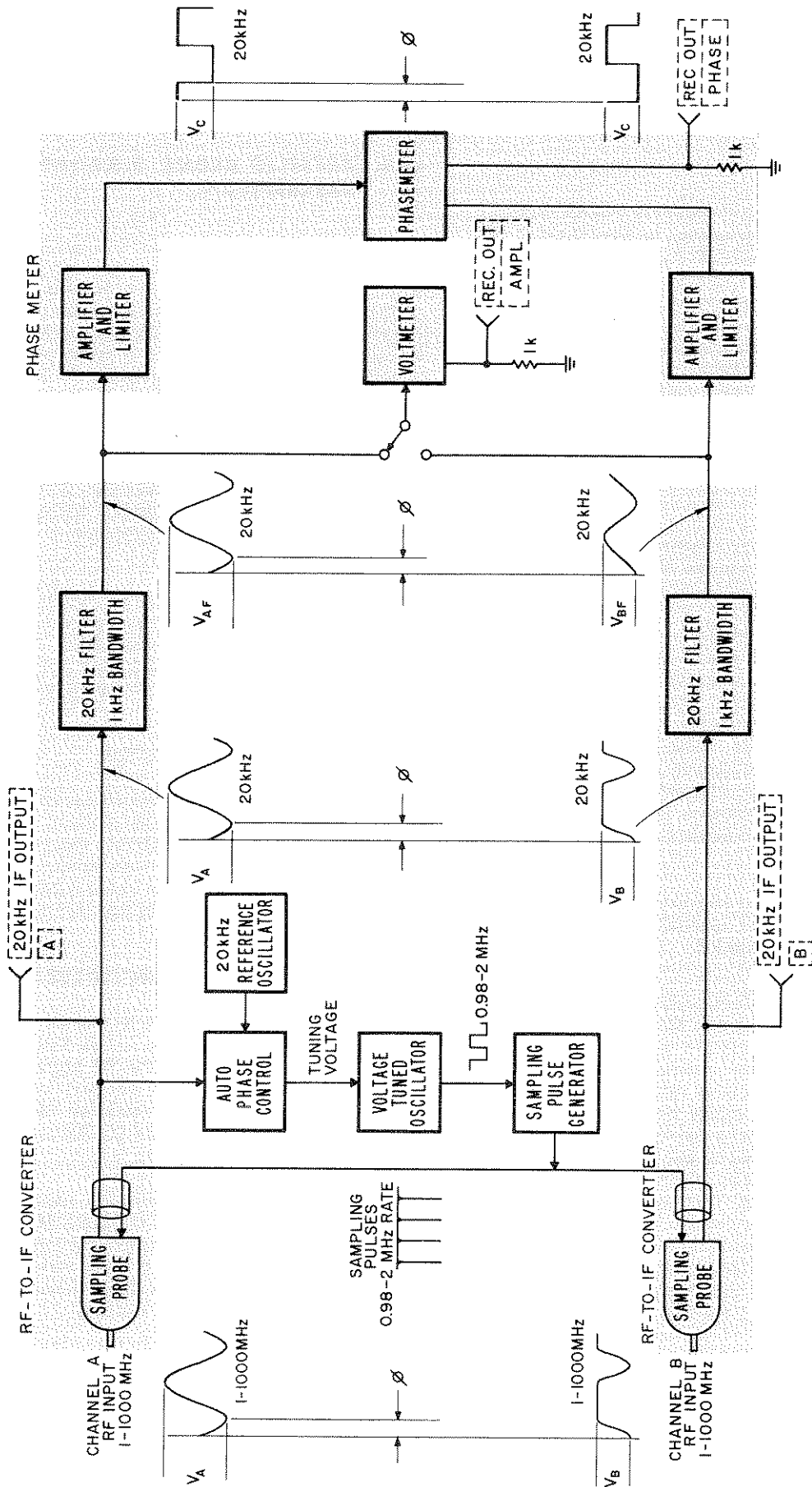

Figure 4-1. Simplified Overall Block Diagram

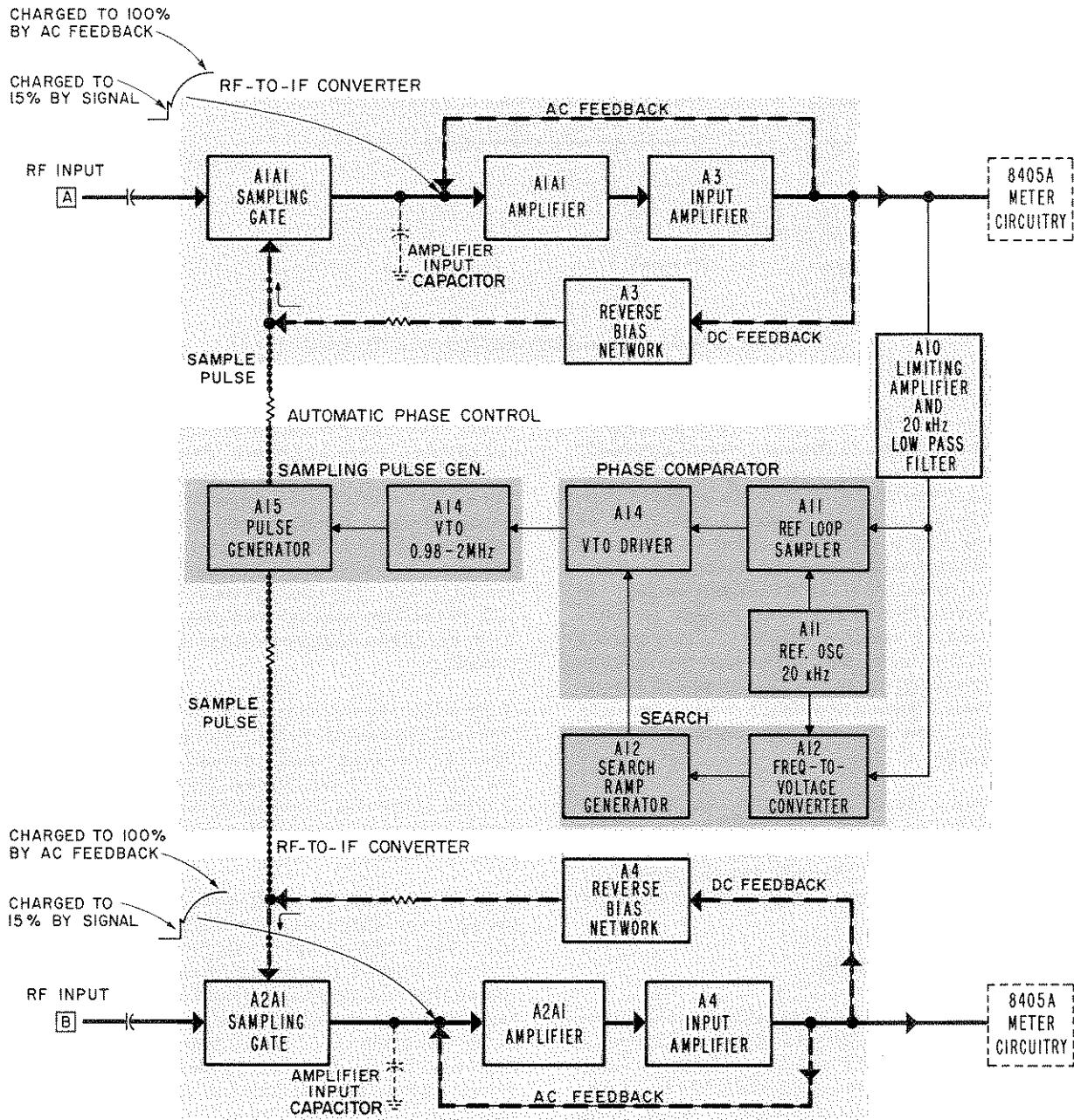

Figure 4-2. Basic Input Circuitry

occurrences of, and at progressively later points on, the high frequency waveform. The time taken to collect enough samples to reconstruct a cycle of the high frequency signal is much longer than the period of one cycle of the sampled waveform. Thus, the high frequency waveform is time-stretched to a low frequency waveform (Figure 4-3).

4-21. SAMPLER.

4-22. The sampler is the means of reconstructing a fast waveform on a much longer time base. Very simply, the sampler is an electronic switch between the fast waveform and an input capacitor as shown in

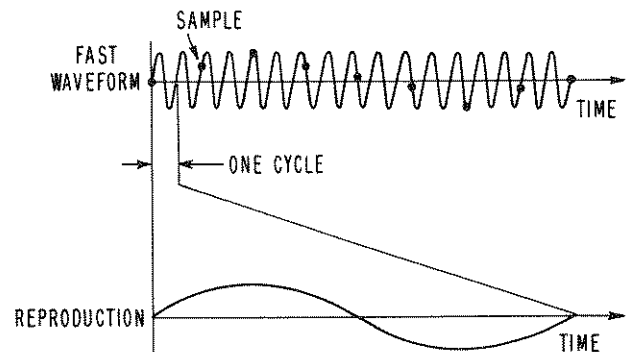

Figure 4-3. Fast Waveform Reproduced on Slower Time Base by Sampling

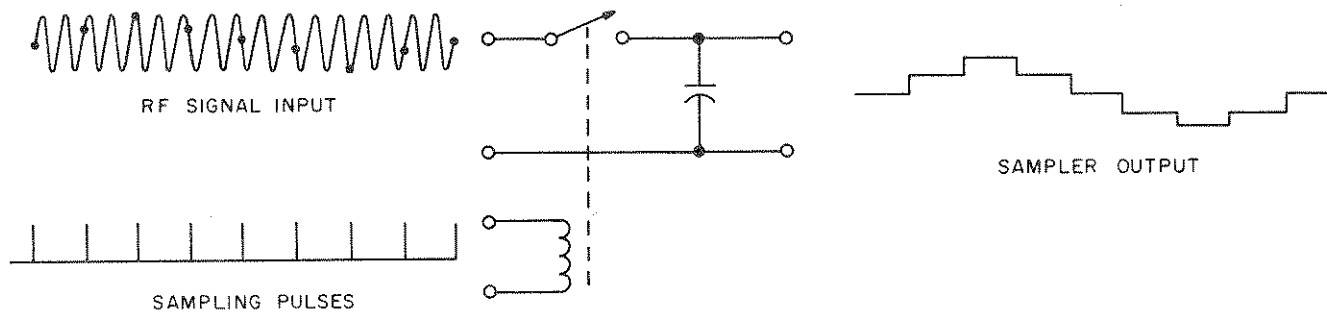

Figure 4-4. Simplified Diagram of a Sampler

Figure 4-4. Each time the switch is closed the capacitor charges to the voltage of the input signal and holds this voltage until the switch closes again. With appropriate timing of the switch the voltage on the capacitor reconstructs the sampled waveform with a series of steps. In this way a cycle of the fast waveform is reproduced in whatever the interval needed to collect enough samples to make a faithful reproduction. In the Vector Voltmeter the switch is electronic and controlled by very short duration pulses. These pulses close the switch for such a short time that the storage capacitor does not fully charge to the voltage of the input signal. Between pulses a feedback circuit supplies enough charge to make the stored voltage equal the input signal voltage.

4-23. One sampler is in each input channel. The sampling switches, or gates, are operated by pulses from the same source; therefore, samples are taken at the same instant in each channel, and the phase relationship of the input signals is preserved in the IF signals.

4-24. CIRCUIT DESCRIPTION.

4-25. There are two identical samplers, one at the input to each channel. The circuits of channel A sampler are on assemblies A1A1 and A3, and the circuits of channel B sampler are on assemblies A2A1 and A4. Assemblies A1A1 and A2A1 are housed in the input probes of channels A and B, respectively. (See Figure 7-6.)

4-26. As shown in the simplified diagram of Figure 4-2, each sampler consists of a sampling gate, an amplifier input capacitor, an ac feedback circuit and a reverse bias circuit. The sampling gate is between the RF input signal and amplifier input capacitor. The gate is a bridge of four fast-switching, hot carrier diodes which are normally back biased, by reverse bias network, so that the input signal does not cause them to conduct. When the input signal is to be sampled, pulses of very short duration momentarily overcome the back bias and switch the diodes into conduction. The amplifier input capacitor then starts to charge toward the voltage of the input signal. However, the sampling pulses are of such short duration that the capacitor charges to only a fraction of the input voltage while the bridge diodes are conducting. The rest of the charging is done between samples.

4-27. The voltage across the input capacitor is the input of a two stage amplifier. Feedback from the output to the input of this amplifier completes the charging of the input capacitor. The amount of feedback is variable so that the IF voltage output of the sampler when the input capacitor is fully charged can be set to equal the RF input voltage when the sample was taken. This feedback charging process takes place in a small fraction of the time between samples, and the charge holds from sample to sample because there is no discharging circuit.

4-28. The reverse biasing of the sampling gate diodes is a critical factor in the operation of the samplers. The reverse bias must prevent the largest signals in the input range from causing the diodes to conduct, yet it must allow the fixed amplitude sampling pulses to forward bias the diodes in a way that gives best sampling efficiency.

4-29. Sampling efficiency is the measure of how nearly the sampler output voltage duplicates the input voltage. Since the sampler characteristically averages any input voltage change that occurs during the sample, the shorter the sampling time the greater the sampling efficiency. Sampling time is governed by the width of the sampling pulse at the point where it exceeds the back bias on the sampling diodes. Since the sampling pulses are roughly triangular but of fixed amplitude, sampling time depends upon the level of reverse bias. Each sampling gate has a bias control.

4-30. Sampling gate bias is controlled by the Reverse Bias Network. Operation of the reverse bias is as follows: While the diode gate is closed, the Reverse Bias Network shifts the bias voltages applied to either side of the gate so that the sampling gate output voltage is centered between them. This ensures equal levels of reverse bias voltage applied to each diode of the gate. The two turn-on pulses are applied to the diode gate simultaneously. Since these pulses have opposite polarity and should be identical, they will turn on both sides of the gate simultaneously. Also, if they are identical and of opposite polarity they will cancel each other at the input and output of the gate.

4-31. However, due to slight differences in the amplitudes and shapes, the sampling pulses do not quite cancel. Compensation for these effects and proper operation of the sampling gate is as follows: 1. Fine

adjustment of the Reverse Bias Network for proper centering operation is set by the Symmetry Adjust, A3R15 for Probe A A4R15 for Probe B; 2. The on-time, or sampling efficiency of the diode gages, is adjusted by varying the level of reverse bias which the pulses must overcome with the Bias Adjust, A3R20 for Probe A, A4R20 for Probe B; 3. Fine adjustment of AC feedback which ensures that sampling gate output is equal to RF input level, is made with the Gain Adjust, A3R5 for Probe A A4R5 for Probe B.

4-32. THE AUTOMATIC PHASE CONTROL.

4-33. The Automatic Phase Control (APC) is a self-tuning local oscillator which generates the sampling pulses for both RF-to-IF Converters and automatically controls the pulse rate to produce 20 kHz IF signals which have the same phase relationship as the RF input signals.

4-34. The APC is operated by the output of channel A sampler and consists of three main sections as shown in Figure 7-4. These are the Sampling Pulse Generator, Search, and Phase Comparator sections, the SPG section produces two in-step pulses. One gates a sample in channel B. The sampling pulse rate is controlled by a voltage tuned oscillator (VTO) for which the tuning voltage is supplied by the search and lock phase-comparator sections.

4-35. The Search and Phase Comparator sections frequency-lock and phase-lock channel A IF signal to a 20 kHz reference oscillator. To get initial locking the search section applies a ramp voltage to the VTO. This ramp voltage sweeps the sampling pulse rate until channel A IF is 20 kHz and in phase with the reference oscillator. Then the sweep stops and the lock section holds channel A IF in phase with the reference oscillator. The lock section also regulates the sampling rate to follow small changes of frequency at probe A input provided that the rate of change does not exceed 15 MHz per second.

4-36. SEARCH SECTION.

4-37. The search section consists of the circuit sections outlined in Figure 7-4. The section varies the sampling rate until the fundamental frequency of channel A sampler output is 20 kHz with the same phase as the 20 kHz Reference Oscillator and the same polarity as the RF input signal.

4-38. The input to the search section is the output of channel A sampler. If the sampler output does not have a fundamental frequency of 20 kHz the Search Ramp Generator produces a ramp voltage which sweeps the output frequency of the Voltage Tuned Oscillator. Since the VTO controls the rate of the Sampling Pulse Generator, the sampling rate follows the VTO frequency.

4-39. When the sampling rate is such that the fundamental frequency of channel A sampler output is 20 kHz and in phase with the 20 kHz Reference Oscillator (A11 Assy) searching stops and thus the lock section holds sampling rate.

4-40. The VTO frequency, and therefore the sampling rate can be varied from 0.98 to 2 MHz. For any frequency in the input range of channel A many sampling rates in this range can produce an IF waveform with a 20 kHz fundamental frequency. However, only one sampling rate gives the truest reproduction of the RF waveform, and that is the highest sampling rate for which the resulting IF waveform has the same polarity as the RF waveform. Thus, the main requirements for the signals out of the samplers are a fundamental frequency of 20 kHz, polarity the same as the RF input waveform, and a high sampling rate.

4-41. The 20 kHz fundamental frequency is obtained by locking the fundamental frequency of channel A sampler output to a 20 kHz reference oscillator. Correct IF waveform polarity is obtained with an identifier circuit that stops a search at the highest sampling rate that has a multiple 20 kHz below the input frequency. High sampling rate is assured by having each search sweep the sampling rate from the high to the low end of its range, and by restricting the sweep to the highest range of sampling rates which can produce IF signals for the selected input frequency range.

4-42. To further increase search efficiency the slope of the VTO tuning ramp is automatically varied during the search by the Frequency to Voltage Converter to control the speed of the search: the farther the sampling rate from lock, the faster the sweep.

4-43. The part of the search circuit that assures the same polarity in the sampler output and RF input is the Sideband Identifier which stops the search at the highest sampling rate which has a multiple 20 kHz below the fundamental frequency of the input RF signal. The Sideband Identifier operates as follows. Sampler A output is amplified, filtered, and clipped to give a square waveshape. This square wave is converted by Phase Inverter A12Q1 to two square waves with a phase difference of 180°. One of these square waves is the input to the Sideband Identifier. The Identifier is a sampling phase detector triggered by the 20 kHz Reference Oscillator. When the sampling rate in channel A RF-to-IF Converter is producing an IF signal of the correct polarity the output of the Identifier has a polarity that stops the search.

4-44. While searching is in progress Lamp Driver A12Q6 holds the front-panel APC UNLOCKED lamp lighted.

4-45. When the tuning ramp applied to the VTO by the search circuit reaches the voltage that gives the correct sampling rate in the RF-to-IF Converter the search stops and a holding circuit applies an equivalent static voltage to the VTO. The holding circuit consists of the Phase Comparator outlined in Figure 7-4, and operates as follows: Voltage samples timed by the 20 kHz Reference Oscillator are taken from the fundamental component of sampler A output. If the frequency of the fundamental is 20 kHz the voltages of the sampler are equal and within the tuning voltage range of the VTO. For a particular frequency at the input to sampler A, the voltages of these holding circuit samples tune the

VTO to the frequency which gives the sampling rate which produces a 20 kHz IF. The holding circuit also permits the signal into sampler A to change frequency a small amount without causing a search.

4-46. The holding circuit is arranged so that two samples are taken from every cycle of sampler A output. This feature gives faster response to any tendency toward IF change. The Limiter Amplifier converts sampler A output to a square waveform. The Low Pass Filter and $+90^\circ$ Phase Shifter extracts the fundamental component from this waveform and shifts it in phase to lead by 90° . Phase Inverter A11Q2 converts this fundamental component to two signals with the same waveshape but different in phase by 180° . Each of these signals is an input to an IF Sampler. The other input to each sampler originates at the 20 kHz Reference Oscillator. The 20 kHz Reference Oscillator has two outputs which approximate square waves

and have steep negative-going slopes. These square waves differ in phase 180° ; therefore, the negative-going slopes are separated in time by 25 microseconds. These slopes trigger the Pulse Generators to produce negative pulses 25 microseconds apart. The pulses gate the IF Samplers. If the fundamental frequency of sampler A output is 20 kHz the samplers are gated to pass small segments from the negative-going slopes of the signals from the phase Inverter, and these segments all have the same voltage and are within the tuning voltage of the VTO.

4-47. Decoupling diodes A19CR1 and A20CR1 prevent crosstalk between channel A input and channel B input. Delay Line A17 is a section of transmission line which can be mechanically adjusted to equalize the electrical distance from the Sampling Pulse Generator to the samplers.

SECTION V MAINTENANCE

5-1. INTRODUCTION.

5-2. This section provides instructions for performance testing, calibrating, troubleshooting, and repairing the Vector Voltmeter. If the serial prefix (the first three numbers of the serial number) of your instrument is different than that listed on the title page of this manual, then there are differences between your instrument and the instrument described in this manual (refer to Paragraph 1-20).

5-3. PERFORMANCE TESTING.

5-4. PURPOSE. The procedures listed in Table 5-2 check 8405A performance for incoming inspection, periodic evaluation, calibration, and troubleshooting. The tests can be performed without access to the instrument interior. The specifications of Table 1-1 are the performance standards.

5-5. TEST EQUIPMENT REQUIRED. The test instruments and accessories required to make the performance checks are listed in Table 5-1. Test instruments other than the ones listed can be used provided their performance equals or exceeds the Critical Specifications listed.

5-6. ADJUSTMENTS.

5-7. PURPOSE. The procedures listed in Table 5-3 outline the adjustments necessary to align the 8405A. The adjustments are sequential and should always be made in the order given. However, realignment of the Power Supply does not normally have to be followed by any of the other adjustment procedures. These adjustments should be made only when it is determined that the instrument is not operating properly. To determine proper operation, refer to Paragraph 5-3.

5-8. TEST EQUIPMENT REQUIRED. The test instruments required for alignment are listed in Table 5-1. Test instruments other than those listed may be used provided their performance equals or exceeds the Critical Specifications listed.

5-9. TROUBLESHOOTING.

5-10. LOCATING TROUBLE.

5-11. Always start locating trouble with a thorough visual inspection for burned-out or loose components, loose connections, or any conditions which suggest a source of trouble. Check the fuse to see that it is not open.

5-12. If trouble cannot be isolated to a bad component by visual inspection, the trouble should be isolated to a circuit section. Isolation to a circuit section can be accomplished by using the troubleshooting charts (Table 5-4 through 5-9). To isolate trouble to a definite circuit component, refer to the next paragraph.

5-13. COMPONENT TROUBLE ISOLATION.

5-14. The following procedures and data are given to aid in determining whether a transistor is operational. Tests are given for both in-circuit and out-of-circuit transistors and should be useful in determining whether a particular section trouble is due to a faulty transistor or an associated component.

5-15. IN-CIRCUIT TESTING.

5-16. The common causes of transistor failures are internal short- and open-circuits. In transistor circuit testing the most important consideration is the transistor base - emitter junction. Like the control grid of a vacuum tube, this is the operational control point in the transistor. This junction is essentially a solid-state diode. For the transistor to conduct, the diode must conduct; that is, the diode must be forward biased. As with simple diodes, the forward-bias polarity is determined by the materials forming the junction. Use the transistor symbol on the schematic diagram to determine the bias polarity required to forward-bias the base-emitter junction. Figure 5-1 shows transistor symbols with terminals labeled. Notice that the emitter arrow points toward the type N material. The other two columns of the illustration compare the biasing required to cause conduction and cut-off in transistors and vacuum tubes. If the transistor base-emitter diode (junction) is forward-biased the transistor conducts. If the diode is heavily forward-biased, the transistor saturates. However, if the base-emitter diode is reverse-biased the transistor is cut off (open). The voltage drop across a forward-biased emitter-base diode varies with transistor collector current. For example, a germanium transistor has a typical forward-bias, base-emitter voltage of 0.2-0.3 volts when collector current is 1-10 ma, and 0.4-0.5 volts when collector current is 10-100 ma. In contrast, forward-bias voltage for silicon transistors is about twice that for germanium types: about 0.5-0.6 volts when collector current is low, and about 0.8-0.9 volts when collector current is high.

5-17. When examining a transistor stage, first determine if the emitter-base diode is biased for conduction (forward-biased) by measuring the voltage difference between emitter and base. When using an electronic voltmeter, do not measure directly between emitter and base: there may be sufficient loop current between the voltmeter leads to damage the transistor. Instead, measure each voltage separately with respect to a voltage common point (e.g., chassis). If the emitter-base diode is forward-biased, check for amplifier action by short-circuiting base to emitter while observing collector voltage. The short circuit eliminates base-emitter bias and should cause the transistor to stop conducting (cut off). Collector voltage should then shift to near the supply volt-

age. Any difference is due to leakage current through the transistor and, in general, the smaller this current, the better the transistor. If collector voltage does not change the transistor has either an emitter-collector short circuit or emitter-base open circuit.

5-18. OUT-OF-CIRCUIT TESTING.

5-19. The two common causes of transistor failure are internal short- and open-circuits. Remove the transistor from the circuit and use an ohmmeter to measure internal resistance. See Table 5-1A for measurement data.

CAUTION

Most ohmmeters can supply enough current or voltage to damage a transistor. Before using an ohmmeter to measure transistor forward or reverse resistance, check its open-circuit voltage and short-circuit current output ON THE RANGE TO BE USED. Open-circuit voltage must not exceed 1.5 volts and short-circuit current must be less than 3 mA. See Table 5-1B for safe resistance ranges for some common ohmmeters.

Table 5-1A. Out-of-Circuit Transistor Resistance Measurements

Transistor Type		Connect Ohmmeter		Measure Resistance (ohms)
		Pos. lead to	Neg. lead to	
PNP Germanium	Small Signal	emitter	base*	200-250
		emitter	collector	10K-100K
	Power	emitter	base*	30-50
		emitter	collector	several hundred
PNP Silicon	Small Signal	emitter	base*	10K-100K
		emitter	collector	very high (might read open)
NPN Silicon	Small Signal	base	emitter	1K-3K
		collector	emitter	very high (might read open)
	Power	base	emitter	200-1000
		collector	emitter	high, often greater than 1M
* To test for transistor action, add collector-base short. Measured resistance should decrease.				

Table 5-1B. Safe Resistance Ranges for Common Ohmmeters

Ohmmeter	Safe Range(s)	Open Ckt Voltage	Short Ckt Current	Lead	
				Color	Polarity
HP 412A HP 427A	R x 1K	1.0V	1 mA	Red	+
	R x 10K	1.0V	100 μ A		
	R x 100K	1.0V	10 μ A	Black	-
	R x 1M	1.0V	1 μ A		
	R x 10M	1.0V	0.1 μ A		
HP 410C	R x 1K	1.3V	0.57mA	Red	+
	R x 10K	1.3V	57 μ A		
	R x 100K	1.3V	5.7 μ A	Black	-
	R x 1M	1.3V	0.5 μ A		
	R x 10M	1.3V	0.05 μ A		
HP 410B	R x 100	1.1V	1.1 mA	Black	+
	R x 1K	1.1V	110 μ A		
	R x 10K	1.1V	11 μ A	Red	-
	R x 100K	1.1V	1.1 μ A		
	R x 1M	1.1V	0.11 μ A		
HP 414A	500K	1.0V	110 μ A	Black	+
	150K	0.5V	110 μ A		
	50K	0.3V	110 μ A	Red	-
	15K	0.2V	110 μ A		
Simpson 260	R x 100	1.5V	1 mA	Red	+
				Black	-
Simpson 269	R x 1K	1.5V	0.82 mA	Black	+
				Red	-

TRANSISTOR BIASING			
DEVICE	SYMBOL	CUT OFF	CONDUCTING
VACUUM TUBE			
N P N TRANSISTOR			
P N P TRANSISTOR			

Figure 5-1. Transistor Biasing Characteristics

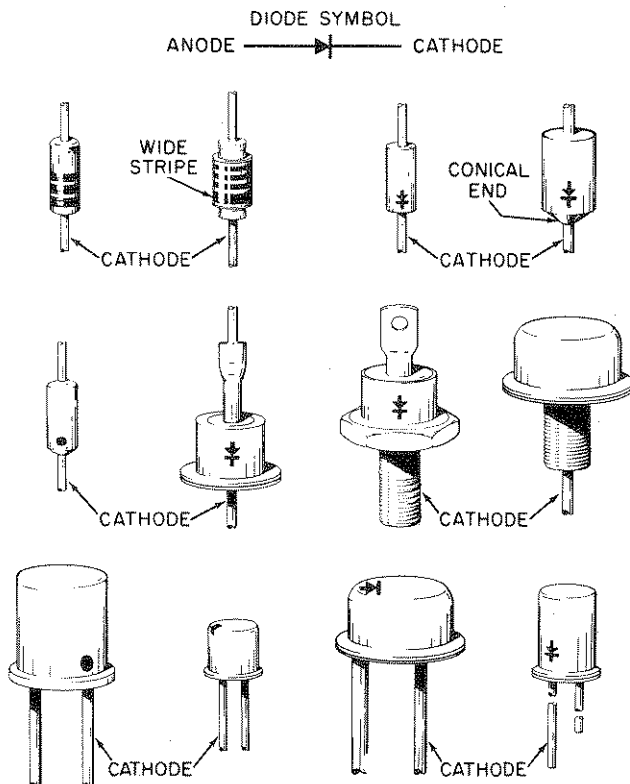

Figure 5-2. Examples of Diode Marking Methods

5-20. REPAIR AND REPLACEMENT.

5-21. Certain procedures and precautions must be followed when repairing or replacing any component of the 8405A. Most of the amplifier and power supply circuit components are located on the etched circuit board. Instructions for working on the etched circuit board are summarized in Paragraph 5-22. Always disconnect the AC power before replacing or soldering any parts.

5-22. ETCHED CIRCUITS.

5-23. The etched circuit boards in the 8405A are of the plated-through type consisting of metallic conductors bonded to both sides of insulating material. Soldering can be done from either side of the board with equally good results. Table 5-1C lists required tools and materials. Following are recommendations and precautions pertinent to etched circuit repair work.

a. Avoid unnecessary component substitution: it can result in damage to the circuit board and/or adjacent components.

b. Do not use a high-power soldering iron on etched circuit boards. Excessive heat may lift a conductor or damage the board.

c. Use a suction device (Table 5-1C) or wooden toothpick to remove solder from component mounting holes. **DO NOT USE A SHARP METAL OBJECT SUCH AS AN AWL OR TWIST DRILL FOR THIS PURPOSE. SHARP OBJECTS MAY DAMAGE THE PLATED-THROUGH CONDUCTOR.**

d. After soldering, remove excess flux from the soldered area and apply a protective coating to prevent contamination and corrosion. See Table 5-1C for recommendations.

5-24. COMPONENT REPLACEMENT.

- a. Remove defective component from circuit board.
- b. Remove solder from mounting holes using a suction desoldering aid (Table 5-1C) or wooden toothpick.
- c. Shape leads of replacement component to match mounting hole spacing.
- d. Insert component leads into mounting holes and position component as original was positioned. **DO NOT FORCE LEADS OF REPLACEMENT COMPONENT INTO MOUNTING HOLES.** Sharp lead ends may damage plated-through conductor.

Note: Axial lead components, such as resistors and tubular capacitors, can be replaced without unsoldering. Clip leads near body of defective component, remove component and straighten leads left in board. Wrap leads of replacement component one turn around original leads. Solder wrapped connection, and clip off excess lead

5-25. ETCHED CONDUCTOR REPAIR. A broken or burned section of conductor can be repaired by bridging the damaged section with a length of tinned copper wire. Allow adequate overlap and remove any varnish from etched conductor before soldering wire into place.

Table 5-1C. Etched Circuit Soldering Equipment

Item	Use	Specification	Item Recommended
Soldering Tool	Soldering Unsoldering	Wattage rating: 37.5 Tip Temp: 750 - 800°F Tip Size: 1/8" OD	Ungar #776 Handle with Ungar #1237 Heating Unit
Soldering Tip, general purpose	Soldering Unsoldering	Shape: chisel Size: 1/8"	Ungar #PL113
De-soldering aid	Unsoldering multi- connection components (e.g., tube sockets)	Suction device to remove molten solder from connection	Soldapult by the Edsyn Company, Arleta, California
Resin (flux) solvent	Remove excess flux from soldered area before application of protective coating	Must not dissolve etched circuit base board ma- terial or conductor bonding agent	Freon Acetone Lacquer Thinner Isopropyl Alcohol (100% dry)
Solder	Component replacement Circuit board repair Wiring	Resin (flux) core, high tin content (60/40 tin/ lead), 18 gauge (SWG) preferred	
Protective Coating	Contamination, corrosion protection after soldering	Good electrical insula- tion, corrosion- prevention properties	Krylon* #1302 Humiseal Protective Coating, Type 1B12 by Columbia Technical Corp. Woodside 77, New York

*Krylon Inc., Norristown, Pennsylvania

5-26. TRANSISTOR REPLACEMENT.

- a. Do not apply excessive heat. See Table 5-1C for soldering tool specifications.
- b. Use a heat sink such as pliers or hemostat between transistor body and hot soldering iron.
- c. When installing a replacement transistor, ensure sufficient lead length to dissipate heat of soldering by maintaining about the same length of exposed lead as used for original transistor.

5-27. DIODE REPLACEMENT.

5-28. Solid state diodes are in many physical forms. This sometimes results in confusion as to which lead or connection is for the cathode (negative) or anode (positive), since not all diodes are marked with the standard symbols. Figure 5-2 shows examples of some diode marking methods. If doubt exists as to polarity, an ohmmeter may be used to determine the proper connection. It is necessary to know the polarity of the ohms lead with respect to the common lead for the ohmmeter used. (For the HP Model 410B Vacuum Tube Voltmeter, the ohms lead is negative with respect to the common; for the HP Model 412A DC Vacuum Tube Voltmeter, the ohms lead is positive with respect to the common.) When the ohmmeter indicates the least diode resistance, the cathode of the diode is connected to the ohmmeter lead which is negative with respect to the other lead (see Table 5-1B).

Note: Replacement instructions are the same as those listed for transistor replacement.

Table 5-1. Recommended Test Equipment

Item	Critical Specifications	Use (Note 3)	Recommended Models
Low Pass Filter (Item 8)*	Cut off Freq: 30 MHz Rejection: 60 dB at 36 MHz	1 3	Telonic TLC-30-6-F-E (See Note 1)
	Cut off Freq: 60 MHz Rejection: 40 dB at 120 MHz	1 3	Telonic TLA-60-3-F-E (See Note 1)
	Cut off Freq: 100 MHz Rejection: 40 dB at 200 MHz	1 3	Telonic TLP-100-3-F-E (See Note 1)
	Cut off Freq: 1200 MHz Rejection: 30 dB at 2000 MHz	1 3	HP 360B (See Note 1)
Oscilloscope	Bandwidth: 50 MHz Sweep Range: 1 to 25 μ sec/cm Sweep Trigger: internal or external Input Coupling: ac or dc Vertical Sensitivity: 5 mV/cm, minimum	2 3	HP 175A (Oscilloscope w/HP 1755A (Vert. Amplifier) & HP 10003A (10:1 Divider Probe)
AC Voltmeter	Freq Range: 50-120 Hz, 20 kHz Volt Accuracy: $\pm 3\%$ of full scale (50-120 Hz); $\pm 1\%$ of full scale (20 kHz and 300 mV) Voltage Range: 1 to 300 mV Input Impedance: 2 megohm or greater	3	HP 400 H/E/or EL, or HP 3400A, or HP 741A
Test Oscillator	Output Freq 18-22 kHz Output level (into 600 ohms): 0 to 1 volt rms	3	HP 200 CD, HP 204B, HP 208A, or HP 651A
Variable Attenuator	Attenuation Range: variable in 1 dB steps from 10 to 30 dB Freq Range: 18-20 kHz Nominal Impedance: 600 ohms	3	HP 350D
Square Wave Generator	Output Freq: 160-200 kHz Symmetry: 45/55 Output level (into 25 ohms): 20 mV p-p, minimum	3	HP 211A
Signal Generator	Output Freq: 1-10 MHz Output level (into 50 ohms): 3 volts rms Dial Accuracy: $\pm 3\%$	2 3	1-10 MHz: HP 651A or HP 606A/B
Signal Generator	Freq Range: 10-450 MHz, 450-1000 MHz, 950-1000 MHz Freq Accuracy: $\pm 2\%$ Output level (into 50 ohms): 10-100 MHz: 3V min. 100-450 MHz and 950-100 MHz: 1.0V min. Auxiliary (second) Output into 50 Ohms: 120 mV minimum	3	10-100 MHz: 8601A Generator or 608E Generator & 230A Amplifier 100-450 MHz: 608E 450-1000 MHz: 612A 950-1000 MHz: 8614B
Power Meter, Thermistor Mount, and Calibrator	Freq Range: 100, 110, and 1000 MHz Meter Readout Accuracy: $\pm 0.5\%$ Power Range: +3 to -10 dBm	1 3	HP 431B/C Meter HP 478A Mount HP 8402B Calibrator & Digital Voltmeter (See Note 2) or HP 432A Meter and HP 478 (See Note 4)

Table 5-1. Recommended Test Equipment (Cont'd)

Item	Critical Specifications	Use (Note 3)	Recommended Models
Frequency Counter	Counting Range: 18-22 kHz Accuracy: ± 2 Hz Sensitivity: 100 mV rms	3	18-22 kHz: HP 5212A or HP 5512, or HP 5245L
	Counting Range: 1-410 MHz Accuracy: ± 50 Hz Sensitivity: 100 mV rms	1	1-410 MHz: HP 5245L Counter and HP 5253B Converter
Digital Voltmeter	Voltage Range: ± 0.1 to ± 40 Vdc Accuracy: $\pm 0.15\%$ of reading (± 1.1 mV for 0.1 to 3V range) Minimum Input Impedance: 10 Megohm	1 2 3	HP 5264A (DVM plug- in used with 5245L listed above), or HP 3439A/any plug-in, or HP 3440A/any plug-in.
RF Voltmeter	Freq Range: 10-100 MHz Calibrated Readout Accuracy: .5% at 10 MHz; .6% at 30 MHz; 1% at 60 MHz Voltage Range: 0.5 to 1.5 Volt rms	1 3	Standards laboratory Calibrated HP 411A Meter with Probe inserted in HP 11024A (Type N tee) and Digital Volt- meter (see Note 2)
1*	50 ohm load with male type N connector SWR: less than 1.06 (3 required)	1 2 3	HP 908A
2*	50 ohm Probe Tee with type N connectors (2 required)	1 2 3	HP 11536A
3*	50 ohm adapter (type N female to female)	1	HP 1250-0777 (UG 29B/U)
4*	10 dB coaxial attenuator for 50-ohm line with type N connectors (2 required)	1	HP 8491A (Option 10)
5*	50 ohm adapter (Tee, all connectors type N female) 3 dB power splitter	1 2 3	HP 11549A
6*	50 ohm adjustable air line (adjustable from 60 to 80 cm with GR type 874 connectors) SWR: Less than 1.06 at 1000 MHz	1	General Radio Co. Type 874-LK20L
7*	50 ohm adapter (type N male to GR 874) (2 required)	1	HP 1250-0847 (874-QNP)
8*	Low Pass Filter (see beginning of this list)	1 3	
9*	6 dB coaxial attenuator for 50-ohm line with type N connectors	1	HP 8491A (Option 06)
10*	Thermistor Mount (see Power Meter listed)	1 3	
11*	Probe Tee for RF Voltmeter (see RF Voltmeter listed)	1 3	
12* Calibrated Variable Attenuator	Attenuation Range: 1 to 12 dB in 1 dB steps Accuracy: ± 0.02 dB at 30 MHz ± 0.05 dB at 100 MHz Connectors: Type N female	1	HP H34-355C (See Note 1)

Table 5-1. Recommended Test Equipment (Cont'd)

Item	Critical Specifications	Use (Note 3)	Recommended Models
13*	50 ohm adapter (BNC male to type N female)	1 3	HP 1250-0077 (UG-349A/U)
14*	BNC to 8405A Probe Adapter	1	HP 10218A
15*	50 ohm tee, type N female connectors	1	HP 1250-0846 (UG-28 A/U)
* Item numbers refer to Performance Check and Adjustment Procedure Test Setups.			
<p>NOTES:</p> <ol style="list-style-type: none"> 1. Nominal impedance is 50 ohms with type N connectors (one male and one female). 2. For required power meter and RF voltmeter readout accuracy, a Digital Voltmeter is required. The Digital Voltmeter in the above list will do the job. 3. For USE column: <ol style="list-style-type: none"> 1. Performance check 2. Troubleshooting 3. Adjustment procedure 4. If HP Model 432A Power Meter is used, then Calibrator (8402B) is not required. 			

Table 5-2. Performance Tests

I. SPECIFICATIONS TESTED

1. ISOLATION BETWEEN CHANNELS:	1 to 300 MHz	100 dB
	300 to 1000 MHz	80 dB

I. TEST DESCRIPTION

1. ISOLATION BETWEEN CHANNELS is tested by applying a large amplitude signal to Channel A with no signal applied to B. Crosstalk from Channel A is indicated by the Channel B AMPLITUDE meter reading.

I. PROCEDURE

1. With signal source output at a minimum, connect equipment as shown in Figure 1.

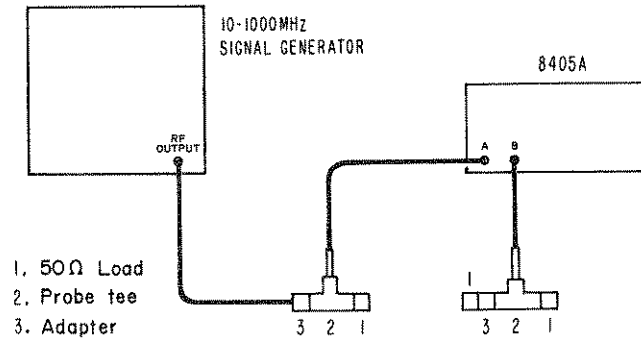

Figure 1. Channel Isolation Check

2. Set signal generator for unmodulated (CW) RF output of about 0 dBm (about 300 mV) and 410 MHz.
3. Adjust 8405A FREQ RANGE-MHz switch so APC UNLOCKED light goes out and setting includes measurement frequency.
4. Set 8405A AMPLITUDE CHANNEL switch to A.
5. Adjust signal generator output for a 0 dB 8405A meter reading.
6. Set 8405A AMPLITUDE CHANNEL switch to B and measure the amplitude signal present on Channel B: The signal amplitude should not exceed -80 dB.
7. Test isolation between channels at any other frequencies between 300 and 1000 MHz.
8. For frequencies 1 to 300 MHz, repeat above procedure with the following exceptions: (a) adjust signal source output for 1 volt Channel A reading; (b) Channel B reading should not exceed 10 microvolts.

II. SPECIFICATIONS TESTED

1. VOLTMETER RESIDUAL NOISE:	10 μ V as indicated on meter.
-------------------------------------	-----------------------------------

II. TEST DESCRIPTION

1. VOLTMETER RESIDUAL NOISE is tested by applying 1 mV to Channel A and reading Channel B with no signal applied to it.

Table 5-2. Performance Tests (Cont'd)

II. PROCEDURE

- 1. Set up equipment as shown in Figure 1 and adjust signal source for 1 mV output.
- 2. Set 8405A AMPLITUDE RANGE to -70 and read voltmeter with AMPLITUDE CHANNEL set to B. Meter indication should not exceed 10 microvolts for Channel B.

III. SPECIFICATIONS TESTED

I. VOLTAGE ACCURACY: Using HP 11536A Probe Tee:

- a. 1 to 100 MHz ±2% of full scale
- b. 100 to 300 MHz ±6% of full scale
- c. 300 to 800 MHz ±12% of full scale
- d. 800 to 1000 MHz ±12% of full scale for up to 300 mV rms
±12% ± 5% of full scale for 300-1000 mV rms

III. TEST DESCRIPTION

- 1. 1 to 100 MHz. Voltage accuracy is tested by applying an accurate rms signal to either input probe. Accuracy of the signal is determined using a calibrated RF voltmeter. To ensure an accurate measurement with the RF voltmeter, the harmonic content of the measured signal must be about 60 dB below the fundamental of interest. Therefore, a low-pass filter is required (for some signal sources, a bandpass filter may be required because the signal source output may contain sub-harmonics).
- 2. 100 to 1000 MHz. Voltage accuracy is tested by applying an accurate rms signal to either input probe. Accuracy of the signal is determined using an RF Power Meter. To ensure an accurate measurement with the Power Meter, the harmonic content of the measured signal must be about 30 dB below the fundamental of interest. Hence, a low-pass filter is required (for some signal sources, a bandpass filter is required because sub-harmonics may be present in RF signal).

III. PROCEDURE

- 1. 1 to 100 MHz.
 - a. With signal source set to minimum, connect test equipment as shown in Figure 2. Allow one-hour warmup.

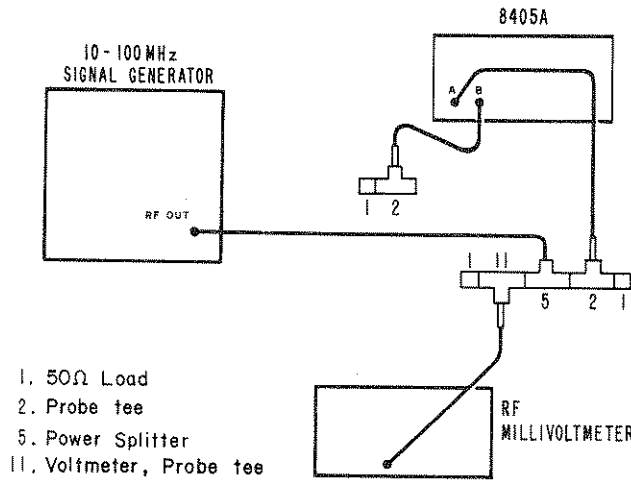

Figure 2. Voltage Accuracy Check (1 to 100 MHz)

Note

For required read-out accuracy, a digital voltmeter should be used with the calibrated RF voltmeter.

- b. Set signal source for 10 MHz unmodulated signal and adjust output level for 1 volt rms as indicated by calibrated RF voltmeter.

Table 5-2. Performance Tests (Cont'd)

- c. Set 8405A FREQ RANGE so that APC UNLOCKED light goes out with range setting including measurement frequency. Note Channel A amplitude meter reading.
- d. Remove 411A Probe and Probe Tee and replace with Channel B Probe Tee. If necessary, adjust signal generator output for Channel A meter reading noted in step c.
- e. Set 8405A AMPLITUDE CHANNEL to B and AMPLITUDE RANGE to 1000 mV; amplitude should read 1.00 ± 0.02 volt.
- f. Repeat above procedure at 30 and 60 MHz. At 30 MHz the 8405A should read 1.00 ± 0.02 volt. At 60 MHz the 8405A can read 1.00 ± 0.03 volt. This is because the RF millivoltmeter (HP 411A) has a calibration accuracy of $\pm 1\%$. This means that the HP 411A could be 1% off at 60 MHz while the 8405A could be off 2% causing the 8405A to appear to be off by 3%.

Note

If the 8405A amplitude reads 1.00 ± 0.01 , it is definitely within $\pm 2\%$ accuracy; if the 8405A reads 1.00 ± 0.03 , it is probably within $\pm 2\%$ accuracy; if the 8405A reading is $1.00 \pm$ greater than ± 0.03 , it is not within $\pm 2\%$ accuracy.

2. 100 to 1000 MHz.

- a. With signal source set to minimum output, connect equipment as shown in Figure 3. Allow one-hour warmup.

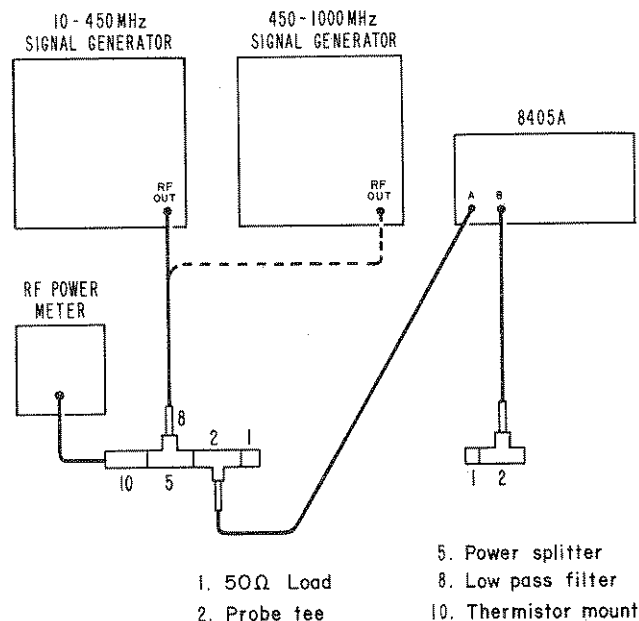

Figure 3. Voltage Accuracy (100 to 1000 MHz)

Note

For maximum power meter readout accuracy: a power meter calibrator (HP 8402B) and digital voltmeter should be used with the power meter. Refer to Operating and Service Manual for power meter calibrator. If the Model 432A Power Meter is used, the Calibrator (8402B) is not required.

- b. Zero and null power meter, then set to 1 mW range.
- c. Set signal source for 100 MHz unmodulated output and adjust for power meter reading which indicates 0.00 dBm level.
- d. Note Channel A AMPLITUDE meter reading. Disconnect thermistor mount from setup and replace with Channel B probe, probe tee and 50 ohm load.
- e. If necessary, readjust signal generator output for Channel A meter reading noted in step d.
- f. Set 8405A AMPLITUDE CHANNEL to B and AMPLITUDE RANGE to 300 mV. Channel B AMPLITUDE meter should read $223.5 \text{ mV} \pm 6 \text{ mV}$.

Table 5-2. Performance Tests (Cont'd)

- g. Set signal source to 200 MHz and repeat steps c, d, and e. Channel B AMPLITUDE meter should read 223.5 mV \pm 18 mV.
- h. Repeat step g for frequencies of interest between 100 and 300 MHz.
- i. Set signal generator for frequencies of interest between 300 and 1000 MHz and repeat steps c, d, and e. Channel B AMPLITUDE meter should read 223.5 mV \pm 36 mV.

IV. SPECIFICATION TESTED

1. VOLTAGE RATIO ACCURACY:

IV. FEATURE TESTED.

VOLTMETER TRACKING.

IV. TEST DESCRIPTION

Range-to-range-voltage tracking is tested by adjusting an input signal for a convenient reference on range of the 8405A Voltmeter. The input signal is then decreased with an accurately calibrated attenuator.

IV. PROCEDURE

1. Set up test equipment as shown in Figure 4.

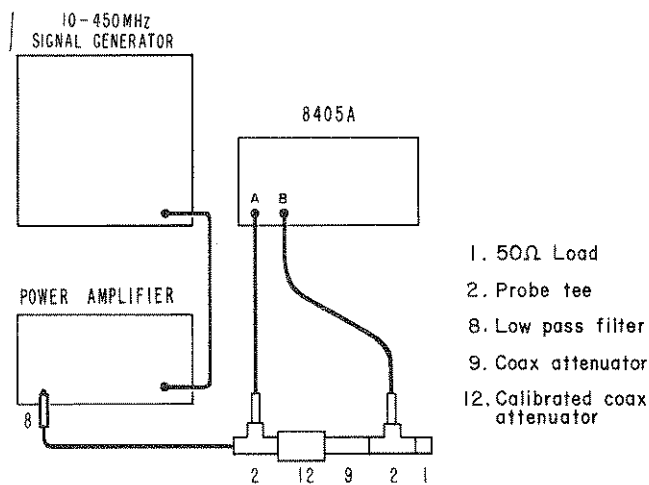

Figure 4. Voltage Ratio Accuracy

2. Set 355C attenuator to 0 dB and set signal source to 30 MHz. Set signal source for about 0 dBm (about 223 mV) output.
3. Set 8405A AMPLITUDE CHANNEL to B and AMPLITUDE RANGE to 0 dB. Adjust FREQ RANGE (MHz) setting to include measurement frequency.
4. Adjust signal source for 0 dB (223.5 mV) 8405A reading.
5. Switch 355C to 1 dB: Amplitude should read 193 to 205 mV + (355C calibration error).
6. Switch 355C to 2 dB: Amplitude should read 172 to 183 mV + (355C calibration error).
7. Switch 355C to 3 dB: Amplitude should read 152 to 164 mV + (355C calibration error).
8. Switch 355C to 4 dB: Amplitude should read 135 to 147 mV + (355C calibration error).
9. Switch 355C to 5 dB: Amplitude should read 120 to 132 mV + (355C calibration error).

Table 5-2. Performance Test (Cont'd)

10. Switch 355C to 6 dB: Amplitude should read 106 to 118 mV + (355C calibration error).
11. Switch 355C to 7 dB: Amplitude should read 93.8 to 106 mV + (355C calibration error).
12. Set 355C to 0 dB and adjust signal source for 0 dB (223.5 mV) 8405A reading on 300 mV range.
13. Set 355C to 10 dB and 8405A to 100 mV range: amplitude should read 68.7 to 72.7 mV + (355C calibration error).
14. Set 355C to 0 dB and adjust signal source for 80 mV 8405A reading on 100 mV range.
15. Set 355C to 10 dB and 8405A to 30 mV range: amplitude should read 24.7 to 25.9 + (355C calibration error).
16. Repeat steps 1 through 15 for any frequency of interest that variable attenuator is calibrated for.

V. SPECIFICATIONS TESTED

I. PHASE ACCURACY: (including phase accuracy due to unequal signal levels to Channel A & B.

- a. Below 500 MHz using HP 11536A Probe Tee (Channel A and B voltages between 100 μV and 300 mV) ±4.5°.
- b. 500 to 1000 MHz using HP 11536A Probe Tee (Channel A and B voltages between 100 μV and 100 mV) ±4.5°.
- c. 1 to 100 MHz using HP 11576A 10:1 Dividers (Channel A and B voltages between 1 mV and 3V) ±5.5°.
- d. 1 to 200 MHz using HP 10216A Isolator (Channel A and B voltages between 100 mV and 300 mV) ±7.5°.

V. TEST DESCRIPTIONS

1. PHASE ACCURACY is tested by separating the input probes by a known electrical line length equal to one wavelength (360° phase shift) at a given frequency. The frequency is then changed in exact increments causing a known phase shift.

NOTE: In general the phase shift caused by a change in frequency of the signal generator in Figure 5 is given by

$$\phi = \frac{f_0 - f}{f_0} (360^\circ)$$

where ϕ = phase shift indicated on 8405A
 f_0 = frequency originally set for 0° phase shift.
 f = new frequency causing phase shift.

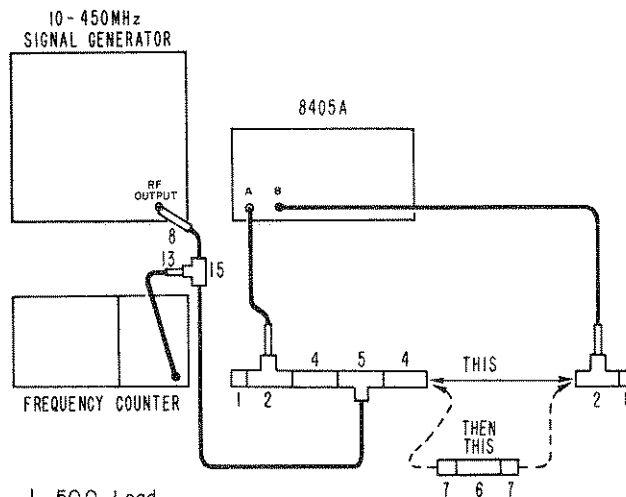

- | | |
|------------------------|-----------------------|
| 1. 50Ω Load | 7. Adapter |
| 2. Probe tee | 8. Low pass filter |
| 4. 50Ω coax attenuator | 13. Adapter |
| 5. Power splitter | 15. Type N female tee |
| 6. Adj air line | |

Figure 5. Phase Accuracy Check

Table 5-2. Performance Tests (Cont'd)

V. PROCEDURES

1. Set up equipment as shown in Figure 5.
2. Using Frequency Counter, adjust signal source for RF output of about 100 mV and frequency as close to 400.000 MHz as possible.
3. Adjust 8405A FREQ RANGE (MHz) so setting includes measurement frequency.
4. Set PHASE RANGE to $\pm 180^\circ$ and METER OFFSET (black knob) to 0° . Using ZERO control, adjust for 0° meter reading. Switch RANGE to $\pm 6^\circ$ and rezero meter as necessary.
5. Insert air line in setup as shown.
6. Adjust air line length for 0° 8405A PHASE meter reading on $\pm 6^\circ$ scale. Remove air line from setup and recheck PHASE METER zero. If necessary, readjust. Reconnect air line in setup and, if necessary, readjust length for 0° reading.
7. Using the following procedure and the frequency counter to determine exact frequency increments, check phase accuracy of 8405A.
 - a. Change frequency to 300 MHz.
 - b. Adjust 8405A FREQ RANGE (MHz) to include measurement frequency. Set PHASE RANGE to $\pm 6^\circ$, METER OFFSET to 90° , and +/- switch to +.
 - c. PHASE meter should read $0 \pm 4.5^\circ$ when air line is reinserted.
 - d. Change frequency to 200 MHz and repeat steps b and c above except that METER OFFSET should be set to 180° .
 - e. Change frequency to 100 MHz and repeat steps b and c above except that METER OFFSET should be 90° , and +/- should be -.
 - f. Repeat similar procedure at frequencies and signal levels of interest, using equation given in Note.

Table 5-3. Adjustment Procedure

INTRODUCTION	
Adjustments should not be made unless it is determined that the instrument is not operating properly. To determine proper operation, see Table 5-2. This adjustment procedure should be followed sequentially. For a list of instrument adjustments and the front panel functions that they affect, see below. See Table 5-1 for required test equipment.	
ADJUSTMENT SUMMARY	
Adjustment	Instrument Function
1. Meter Movement Mechanical Zero	1. Basic accuracy of both meters
2. Power Supply Adjustments	2. All functions
3. IF Section Adjustments	
3A. Channel A IF Tuning and Gain	3A. All functions except, IF OUTPUTS and Channel B voltmeter
3B. Channel B IF Tuning and Gain	3B. All functions except, IF OUTPUTS and Channel A voltmeter
4. Phase Section Adjustments	4. Phasemeter and PHASE recorder output
5. Automatic Phase Adjustments	
5A. IF Sampler	5A. All functions. Note: misadjustment is most noticeable as the cause of low voltmeter readings
5B. Pulse Generator and Sampler	
(1) A3R20/A3R15/A15R3	5B(1). All functions
(2) A4R20/A4R15	5B(2). All functions except Channel A voltmeter.
5C. Search Speed	5C. All functions or, all functions at some frequencies only.
6. RF Section Adjustments	
6A. Channel A RF Gain	6A. Channel A voltmeter
6B. Channel B RF Gain	6B. Channel B voltmeter
NOTE: IF sampler slightly misadjusted (A11R24)	NOTE: Both Channel voltmeters
6C. Delay Line	6C. Phasemeter

Table 5-3. Adjustment Procedure (Cont'd)

1. MECHANICAL METER ADJUST.

- a. When meter is properly set, the pointer resets over the calibration (i. e., 0° or 0 volts) on the meter scale when the instrument is (1) in its normal operating position, and (2) turned off. Set pointer as follows to obtain best accuracy and mechanical stability:

NOTE

For Option 02 instruments, the AMPLITUDE meter has no mechanical adjust.

- b. Turn instrument off
- c. Rotate meter zero-adjust screw clockwise until meter pointer is to left of 0 and moving to right toward 0. Stop pointer at 0. If pointer passes 0, repeat adjustment.
- d. Rotate meter zero-adjust screw about 3 degrees counterclockwise to free it from meter suspension. If pointer moves, repeat steps c and d.

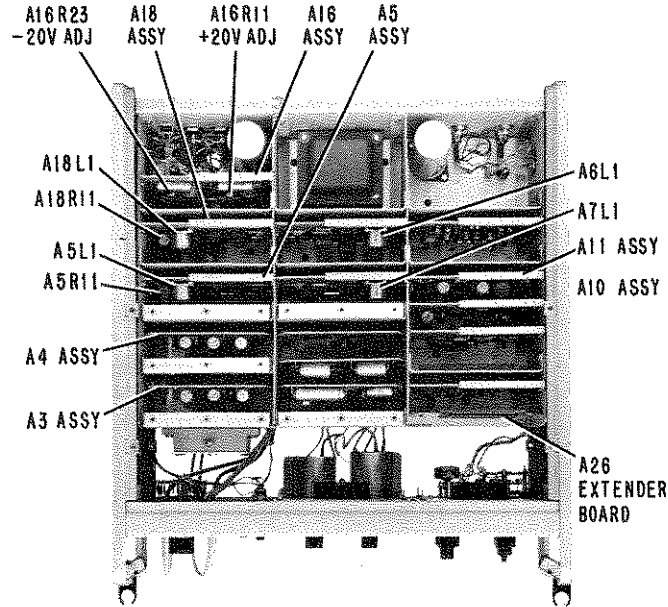

Figure 2A. Adjustment Locations

2. POWER SUPPLY ADJUST.

- a. Remove top cover and refer to Figure 2A.
- b. Put Power Supply assembly A16 on A26 Extender Assembly.
- c. Using a DC Voltmeter and an AC Voltmeter, make the following measurements.

<u>Test Point</u>	<u>Measure (Note 1)</u>	<u>Ripple (Note 2)</u>	<u>Adjust</u>	<u>Line Voltage</u>
A16C6 minus to Chassis gnd	-20±0.2 vdc	1.0mVrms	<u>A16R23</u>	103 to 127 vac or
A16C3 plus to Chassis gnd	+20±0.2 vdc	1.0mVrms	<u>A16R11</u>	207 to 253 vac

Note 1. If either supply has to be adjusted, set output as close to 20.0 volts as possible.

Note 2. If ripple is excessive remove circuit assemblies A3 and A4. Ripple should then be normal. Measure again after Pulse Generator and Sampler Adjustment Procedures.

Table 5-3. Adjustment Procedure (Cont'd)

3. IF SECTION ADJUST.

3A. CHANNEL A IF TUNING AND GAIN.

- a. Connect test equipment as shown in Figure 2B. Connect AC Voltmeter between A5Q1 base and 8405A Chassis. Connect Oscilloscope vertical input between A5C4-A5R8 junction and 8405A chassis.

NOTE

Refer to Figure 2A for adjustment and assembly location.

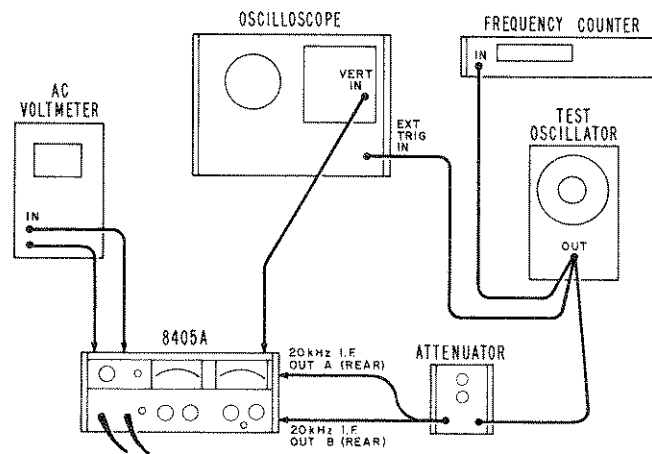

Figure 2B. Setup for IF Tuning, IF Gain and IF Sampler Adjustments

- b. Unplug circuit Assemblies A3, A4, A8, A10 and A11, but for convenience leave them in the 8405A. Put Isolation Amplifier Assembly A5 on extender A26.
- c. Connect 8405A to 115 Vac line.
- d. Set 8405A controls as follows:
 - LINE ON
 - CHANNEL A
 - AMPLITUDE RANGE 300 mV
 - Other control settings optional.
- e. Adjust Test Oscillator/Attenuator to obtain 300 mV reading on the AC Voltmeter at 20 kHz \pm 10 Hz.
- f. Tune A5L1 to peak the 20 kHz sine wave displayed by the Oscilloscope.
- g. Adjust Gain control A5R11 until 8405A AMPLITUDE meter reads 300 millivolts.
- h. Reinsert Phase Meter Assembly A8 and Isolation Amplifier Assembly A5 without the extender.
- i. Put channel A Phase Shifter Assembly A7 on extender A26.
- j. Connect Oscilloscope vertical input between the base of A7Q5 and the 8405A chassis.

Table 5-3. Adjustment Procedure (Cont'd)

- k. Set AMPLITUDE RANGE to 1000 mV, and adjust Test Oscillator output until AMPLITUDE meter reads 1000 mV.
- m. Tune IF adjustment A7L1 to peak the 20 kHz sine wave displayed by the Oscilloscope.
- n. Reinsert Phase Shifter Assembly A7 without the extender.

3B. CHANNEL B IF TUNING AND GAIN.

- a. With test equipment as shown in Figure 2B, and with Circuit Assemblies A3, A4, A10 and A11 still unplugged, put Channel B Isolation Amplifier A18 on extender A26.
- b. Unplug Phase Meter Assembly A8.
- c. Connect the Oscilloscope vertical input between A18C4-A18R8 junction and the 8405A chassis. Connect the AC Voltmeter to the base of A18Q1.
- d. Set 8405A controls as follows:

CHANNEL B
 AMPLITUDE RANGE 300 mV

Other control settings optional

- e. Adjust Test Oscillator/Attenuator to obtain 300 mV reading on the AC Voltmeter.
- f. Tune IF adjust A18L1 to peak the 20 kHz sine wave displayed by the Oscilloscope.
- g. Adjust Gain Control A18R11 until the 8405A AMPLITUDE meter reads 300 mV.
- h. Reinsert Phase Meter A8 and Isolation Amplifier Assembly A18 without the extender.
- i. Put Channel B 180° Switch Assembly A6 on extender A26.
- j. Set 8405A controls as follows:

CHANNEL B
 AMPLITUDE RANGE 1000 mV
 PHASE METER OFFSET -90°

Other control settings optional.

- k. Adjust Test Oscillator output for 8405A AMPLITUDE meter reading of about 1000 mV.
- m. Connect Oscilloscope vertical input between A6C12 minus and the 8405A chassis.
- n. Tune IF adjust A6L1 to peak 20 kHz sine wave displayed by the Oscilloscope.
- o. Reinsert 180° Switch Assembly A6 without the extender.

4. PHASE SECTION ADJUST.

- a. Connect test equipment as shown in Figure 2C.

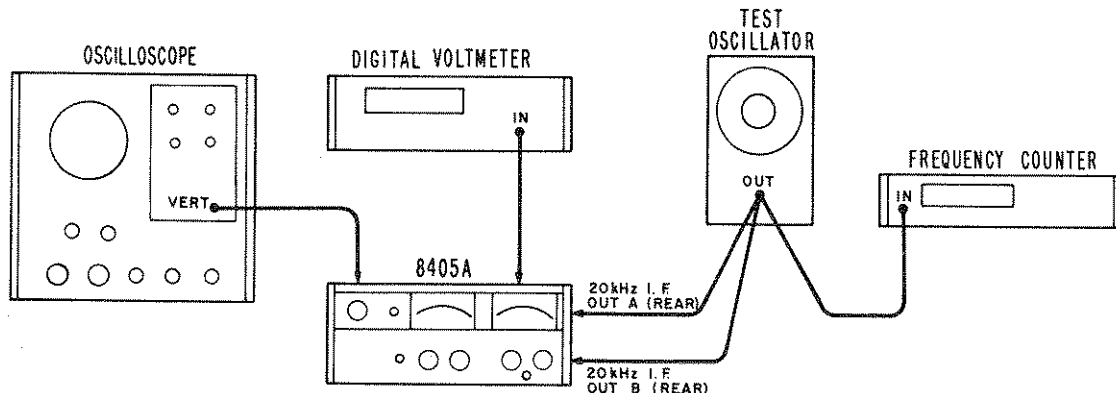

Figure 2C. Setup for Phase Meter Adjustments

NOTE

Refer to Figure 2D for adjustment and assembly location.

Table 5-3. Adjustment Procedure (Cont'd)

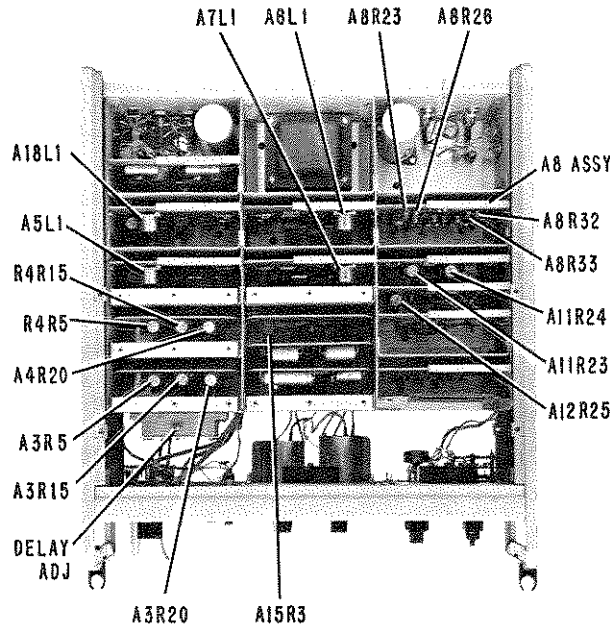

Figure 2D. Adjustment Locations

- b. With Circuit Assemblies A3, A4, A10 and A11 still unplugged, put Phase Meter Assembly A8 on extender A26.
- c. Set 8405A controls as follows:
 PHASE METER OFFSET..... 0
 PHASE RANGE ±60
 AMPLITUDE RANGE 1000 mV
 Other control settings optional
- d. Adjust output of Test Oscillator to obtain 8405A AMPLITUDE meter reading of 1000 mV.
- e. Read PHASE METER with PHASE ZERO fully clockwise and fully counterclockwise. Readings of at least +18° and -18° should be obtained. If not, adjust A8R32 and A8R24.

NOTE

It may be necessary also to retune IF adjustments A6L1 and A7L1 to obtain ±18° zeroing range. Do not, however, obtain more than a 10° correction from any single IF control.

- f. For 8405A Vector Voltmeters without A8R26 and A8R33 adjustments, go to step g. For instruments with A8R26 and A8R33 adjusts, perform steps (1), (2) and (3).
 - (1) Connect Digital Voltmeter to measure voltage at the junction of A8R33 slider and A8Q16 base. Adjust A8R33 until Digital Voltmeter reads +7.4 volts.
 - (2) Connect Digital Voltmeter to measure voltage at the junction of A8R26 slider and A8Q12 base. Adjust A8R26 until Digital Voltmeter reads -7.4 volts.
 - (3) Connect Oscilloscope X10 Probe to junction of A8CR1 and A8R20. Square wave pattern should have no oscillations present. If oscillations are present on pattern, readjust A8R33 and A8R26 as necessary to eliminate oscillations. Final voltages, as measured in steps (1) and (2) above should be between 6.0 and 7.5.
- g. Set 8405A PHASE RANGE and PHASE METER OFFSET to 180.
- h. Adjust PHASE ZERO to obtain maximum positive reading on PHASE meter.
- i. Adjust A8R32 until PHASE meter reads +180°.
- j. Adjust PHASE ZERO to obtain maximum negative reading on PHASE meter.

Table 5-3. Adjustment Procedure (Cont'd)

- k. Adjust A8R24 until PHASE meter reads -180° .
- m. Set 8405A PHASE RANGE to ± 60 and PHASE METER OFFSET to 0.
- n. Repeat steps e and f.
- o. Reinsert Phase Meter Assembly A8 without extender. Also, Assembly A10.

5. AUTOMATIC PHASE CONTROL SECTION ADJUST.

5A. IF SAMPLER.

- a. Connect test equipment as shown in Figure 2B: 8405A control settings are optional.

NOTE

Turn test oscillator on and allow one-half hour warmup.

- b. With Circuit Assemblies A3 and A4 still unplugged, put IF Sampler Assembly A11 on extender A6.
- c. Connect Oscilloscope vertical input and Frequency Counter between A11Q4 Collector (transistor case) and 8405A chassis.
- d. With the Oscilloscope internally synchronized, adjust Symmetry Control A11R23 to obtain 50-50 symmetry for the waveform at A11Q4 collector.
- e. Adjust Frequency Control A11R24 to obtain 20 kHz Frequency Counter reading. If control action prevents precise adjustment $20 \text{ kHz} \pm 10 \text{ Hz}$ is acceptable.
- f. Connect Oscillator to 8405A IF output A. Set Oscillator frequency to 19.9 kHz and amplitude for 10 mV rms at the 8405A IF OUT terminals.
- g. Connect Oscilloscope vertical input to ungrounded side of A11C17 (XA11, pin 5).
- h. Set Oscilloscope for internal sync and sweep time to display about one cycle of the sampling waveform. Magnify Oscilloscope horizontal display 10X and position the waveform to view the negative-going slope. Trim Test Oscillator frequency to reduce amplitude instability on the display.
- i. Adjust Symmetry Control A11R23 until the negative slope of the sampling waveform resembles a staircase. See typical waveforms in Figure 5.

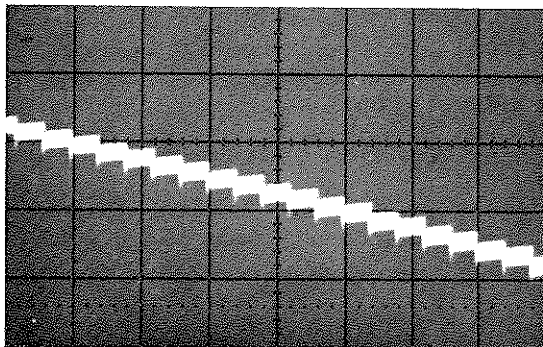

Typical Sampling Waveform When A11R23 Properly Adjusted.

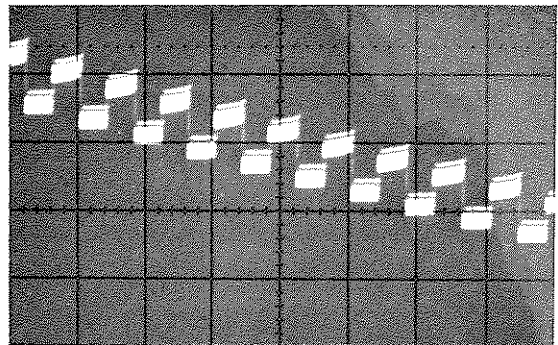

Typical Sampling Waveform When A11R23 Improperly Adjusted.

Figure 2E. Typical Sampling Waveforms

Table 5-3. Adjustment Procedure (Cont'd)

- j. Reinsert IF Sampler assembly A11 without the extender.
- k. Plug in Assemblies A3 and A4 (all circuit boards should now be plugged into their sockets).

NOTE

It is possible to install the A3 and A4 circuit boards in their slot holders and not in their sockets. Whenever installing either circuit board, be sure it is plugged into its socket and not just slot holder.

5B. PULSE GENERATOR AND SAMPLER.

- a. Connect test equipment as shown in Figure 2F.

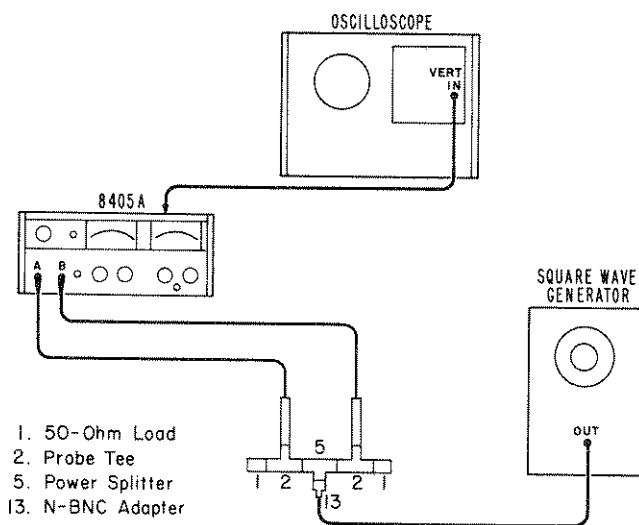

Figure 2F. Setup for Pulse Generator and Sampler Adjustments

- b. Connect Oscilloscope vertical input to rear-panel 20 kHz IF output A. Set Oscilloscope for internal triggering on the positive slope of the waveform.
- c. Set 8405A FREQ RANGE to the 500-1000 MHz position. Other control settings are optional.
- d. Set Square Wave Generator frequency to about 180 kHz and adjust output amplitude to obtain about 200 mV p-p Oscilloscope display. Adjust Oscilloscope triggering sensitivity until sweep just triggers. Waveform should approximate a square wave as shown below.
- e. Adjust pulse generator bias control A15R3 to peak the leading edge of the Oscilloscope waveform.
- f. Adjust Channel A sampler bias control A3R20 for 100% sampling efficiency. Sampling efficiency is 100% when the top of the waveform is nearly flat. See typical waveforms in Figure 2G.

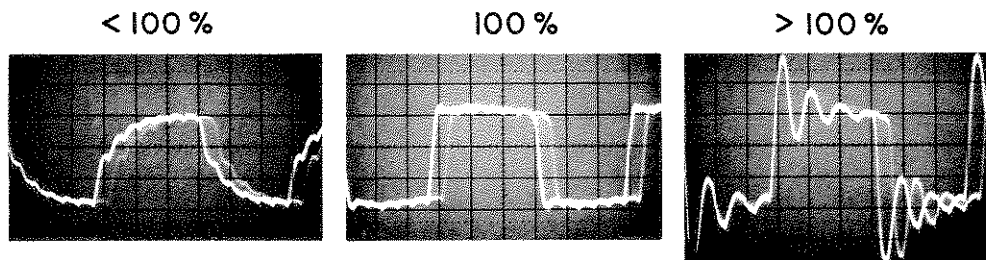

Figure 2G. Typical Sampling Efficiency Waveforms

Table 5-3. Adjustment Procedure (Cont'd)

- g. Adjust Channel B sampler bias control A4R20 for 100% sampling efficiency. See typical waveforms in Figure 2G.
- h. Minimize sampling signal at probe tips as follows:
- (1) Connect the 8405A Channel A probe to the Oscilloscope vertical input with a probe-to-BNC adapter.
 - (2) Adjust Symmetry control A3R15 to minimize the sampling signal. Minimum signal should not exceed 5 mV p-p.
 - (3) Repeat steps 1 and 2 for Channel B probe adjusting Symmetry Control A4R15.
- i. Repeat procedure of steps a through h to assure sampling efficiency is properly adjusted.
- j. If ripple on power supply voltages was excessive at initial measurement, check ripple again. Ripple should be normal.
- 5C. SEARCH SPEED.
- a. Connect test equipment as shown in Figure 2H.

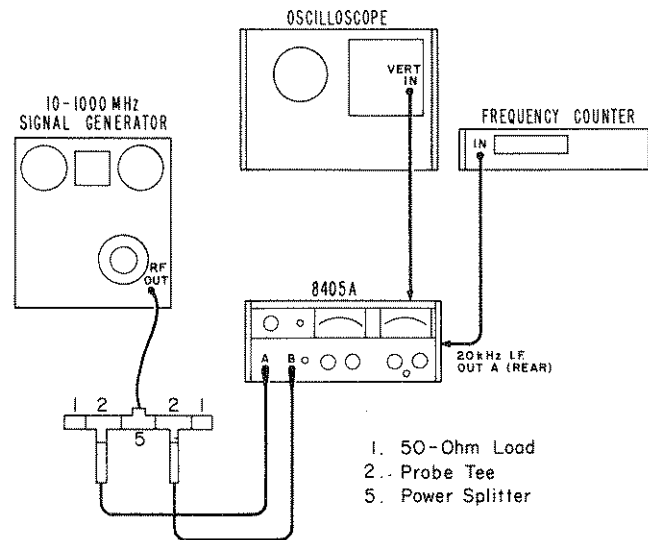

Figure 2H. Setup for Search Speed Adjustment

- b. Put Search assembly A12 on extender A26.
- c. Direct couple Oscilloscope vertical input to the junction of A12Q7 base and A12R25 slider.
- d. Set Signal Generator frequency to 80 MHz and adjust output amplitude to obtain 100 mV AMPLITUDE meter reading for Channel A.
- e. Set 8405A FREQ RANGE to 60-120 MHz, other settings are optional.
- f. Oscilloscope display should be sawtooth waveform. Adjust Search Speed control A12R25 so average voltage of sawtooth is zero.

Table 5-3. Adjustment Procedure (Cont'd)

- g. Reinsert Search assembly A12 without the extender.
- h. Readjust the frequency of the 20 kHz internal reference oscillator as follows:
 - (1) Connect Frequency Counter to 20 kHz IF output A.
 - (2) Adjust Frequency control A11R24 to obtain Frequency Counter reading of 20 kHz. If control action prevents precise adjustment, 20 kHz \pm 10 Hz is acceptable.

6. RF SECTION ADJUST .

6A. CHANNEL A AND B LOW FREQUENCY RF GAIN

- a. Connect test equipment as shown in Figure 2J using the 10 - 450 MHz Signal Generator.

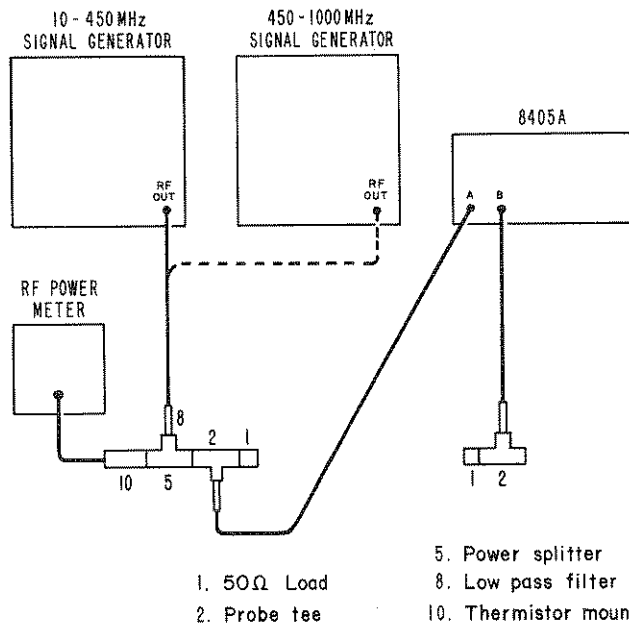

Figure 2J. Setup for RF Gain and Delay Line Adjustments

- b. Set 8405A controls as follows:

AMPLITUDE CHANNEL	A
FREQ RANGE - MHz	100 MHz
AMPLITUDE RANGE	300 mV

Other control settings optional.
- c. Set Signal Generator frequency to 100 MHz and adjust output level to obtain 0.0 dBm reading on RF Power Meter. Remove Thermistor Mount and replace with Channel B Probe Tee.

NOTE

Before removing Thermistor Mount from setup, note Channel A AMPLITUDE meter reading. After replacing Thermistor Mount with Channel B Probe Tee, readjust Signal Generator output level for previously noted Channel A AMPLITUDE meter reading.

Table 5-3. Adjustment Procedure (Cont'd)

- d. Adjust Gain Control A4R5 to make 8405A AMPLITUDE meter read 0 dBm.
- e. Set AMPLITUDE CHANNEL selector to A.
- f. Interchange Probes A and B.
- g. Adjust Gain Control A3R5 to make 8405A AMPLITUDE meter read 0 dBm.

NOTE

If 8405A Meter will not adjust up to 0 dBm, adjust A11R24 for peakmeter reading and repeat step c. If A11R24 is adjusted, repeat Channel B RF Gain adjust. For 8405A instruments, serial numbered 942-02860 and below, it may be necessary to change A3R5 and A4R5 to a 500-ohm potentiometer, HP Part Number 2100-1747 to obtain a greater adjustment range. Also, as part of the change, remove resistors A3R27 and A4R27 and replace each of them with a shorting wire.

- h. With signal source set to minimum, connect test equipment as shown in Figure 2K.

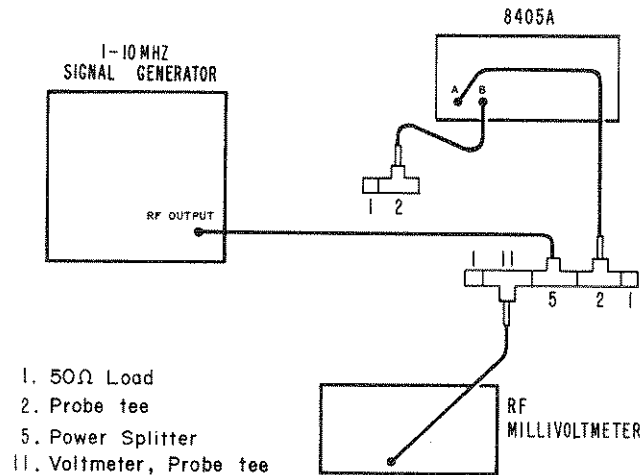

Figure 2K. Setup for RF Gain Adjustment

- i. Set signal source for 1 MHz unmodulated signal and adjust output level for 0 dBm as indicated by calibrated RF voltmeter.
- j. Set 8405A FREQ RANGE so that APC UNLOCKED light goes out and range setting includes measurement frequency. Note Channel A amplitude meter reading.
- k. Remove 411A Probe Tee and replace with Channel B Probe Tee. If necessary, adjust signal generator output for Channel A meter reading noted in step j.
- m. Change 8405A AMPLITUDE CHANNEL to B and RANGE to 0 dB.
- n. Channel B AMPLITUDE meter will, at 1 MHz, read low. Using gain control A4R5, adjust to about -0.2 dBm.
- o. Interchange probes A and B. Channel A AMPLITUDE meter will, at 1 MHz read low. Using gain control A3R5, adjust to about -0.2 dBm.
- p. Recheck Channel A and B amplitude meter readings at 100 MHz as described in steps a through g.
- q. Channels A and B amplitude meters should now read above 0 dBm, but not more than +0.2 dBm. If necessary to readjust gain controls A4R5 and A3R5 at 100 MHz, it will be necessary to recheck the amplitude meter readings at 1 MHz.

Test 5-3. Adjustment Procedure (Cont'd)

6B. VOLTAGE ACCURACY (HIGH FREQUENCY).

- a. Using 1000 MHz Signal Generator, connect test equipment as shown in Figure 2J.
- b. Set 8405A controls as follows:

 AMPLITUDE CHANNEL A
 FREQUENCY RANGE 1000 MHz
 AMPLITUDE RANGE 300 mV
- c. Set Signal Generator frequency to 1000 MHz and adjust output level to obtain 0.0 dBm reading on RF Power Meter. Note Channel A AMPLITUDE meter reading.
- d. Remove Thermistor Mount and replace with Channel B Probe and Probe Tee. If necessary, readjust Signal Generator output level for Channel A AMPLITUDE meter reading noted in step c.
- e. Set AMPLITUDE CHANNEL to B. Channel B AMPLITUDE meter should read high. Note and record reading.
- f. Remove Channel B Probe and replace with Channel A Probe. Channel A AMPLITUDE meter should read high. Record reading.
- g. Place Channel A Probe back in other Probe Tee and set up equipment as shown in Figure 2J.
- h. Set 8405A AMPLITUDE RANGE to +10 dB and switch RF Power Meter to +10 dB range.
- i. Adjust Signal Generator output level to obtain +10 dBm reading.
- j. Note Channel A AMPLITUDE meter reading.
- k. Remove Thermistor Mount and replace with Channel B Probe and Probe Tee. If necessary, readjust Signal Generator output level for Channel A AMPLITUDE meter reading noted in step j.
- m. Set AMPLITUDE CHANNEL to B. Note and record AMPLITUDE meter reading.
- n. Remove Channel B Probe and replace with Channel A Probe. Set AMPLITUDE CHANNEL to A and note and record AMPLITUDE meter reading.
- o. Depending upon your individual 8405A, the greatest amplitude measurement error may be at 0 dBm or at +10 dBm. Having measured the amplitude error for each channel (steps e and m for Channel B; steps f and n for Channel A), set appropriate adjustment so that amplitude error is within specification for each channel: Just within specification at either the 0 or +10 dBm point.

Channel	Adjust	0 dBm Specification	+10 dBm Specification
B	A4R20	188 to 259 mV	.537 to .877 V
A	A3R20	188 to 259 mV	.537 to .877 V

- p. Minimize sampling signal at probe tip as follows:
 - (1) Remove 8405A Probes from test setup, this procedure requires only an Oscilloscope.
 - (2) Connect 8405A Channel A Probe to Oscilloscope vertical input with a probe-to-BNC adapter.
 - (3) Adjust Symmetry Control A3R15 to minimize sampling signal. Peak-to-peak signal level should not exceed 5 mV.
 - (4) Repeat steps 2 and 3 for Channel B Probe adjusting Symmetry Control A4R15.

Table 5-3. Adjustment Procedure (Cont'd)

6C. DELAY LINE

a. Connect test equipment as shown in Figure 2J using the 10 - 100 MHz Signal Generator. Connect Channel B probe in place of Thermistor Mount.

b. Set 8405A controls as follows:

AMPLITUDE CHANNEL A

FREQUENCY RANGE - MHz 10 MHz

AMPLITUDE RANGE -10 dB

c. Set Signal Generator frequency to 10 MHz and adjust output level for -10 dBm 8405A AMPLITUDE meter reading.

d. Adjust PHASE ZERO for 0 PHASE meter reading.

e. Replace the 10 - 100 MHz Signal Generator with the 1000 MHz Generator.

f. Set 8405A FREQ RANGE - MHz to 1000 MHz (fully ccw).

g. Set Signal Generator frequency to 1000 MHz, and adjust output level for -10 dBm AMPLITUDE meter reading.

h. Slowly reduce Signal Generator frequency through 50 MHz noting maximum and minimum PHASE meter readings. Reminder: the PHASE and AMPLITUDE meter pointers will flicker momentarily several times as the input frequency is changed. The flicker is caused by the automatic tuning and is normal.

i. Set Signal Generator to the frequency in the 950-1000 MHz range which gives a PHASE meter reading half way between the maximum and minimum noted in step h.

j. Set Delay Adjust to obtain 0 PHASE meter reading (refer to page 5-18 for Delay Adjust location).

Table 5-4. Front Panel Troubleshooting

GENERAL: Using this procedure, trouble can be isolated to a general circuit section. To isolate trouble within a specific circuit section, refer to schematic diagrams or other troubleshooting charts.

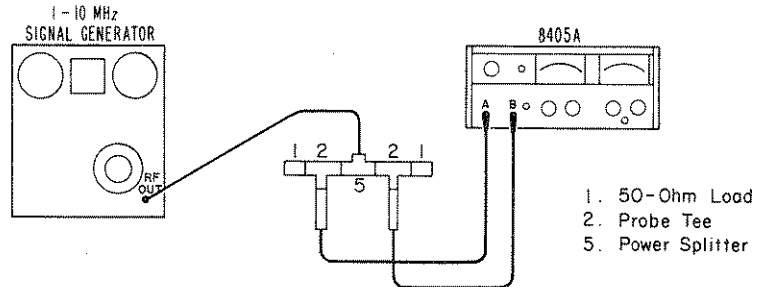

- PROCEDURE:
- Using setup shown above, set Signal Source for 1 MHz, 20 mV RMS output.
 - Set 8405A controls as follows: FREQ RANGE full clockwise (1-4 MHz), 10 mV (-20 dBm), $\pm 60^\circ$, and OFFSET to 0° .
 - In the indications Table below, an "X" indicates failure and an "ok" indicates normal operation.
 - Starting in the upper left-hand corner, if the indication in the instrument agrees with that in the manual, read horizontally. If the indications do not agree, drop down one line. Repeat for each square.

Channel A	Channel B	Phasemeter	APC UNLOCKED	APC UNLOCKED	Circuit Section Trouble
ok	ok	X	ok	ok	(Table 5-7) Phasemeter ckts: A5Q4-6, A6, A7, A8, A18Q4-6
ok	X	X	ok	ok	(Table 5-9) Channel B Ckts
X	ok	X	ok	ok	A5Q1-3
X	X	ok	ok	ok	A9, A22
X	X	X	ok	X	Channel A or APC ckts (Table 5-8) or +20V Power Supply (Table 5-5)
X	X	X	X	ok	-20V Power Supply (Table 5-6), or A11, A12 (Table 5-8) or Primary Power ckt.

- NOTES:
- Channels A and B should read 10 mV $\pm 5\%$ depending upon Signal Source output level accuracy. Two channels should read within $\pm 2\%$ of each other.
 - Phase meter, using ZERO control, should be adjustable at least $\pm 15^\circ$ about 0° .
 - APC unlocked light should be out with FREQ RANGE switch fully clockwise (1-4 MHz).
 - APC unlocked light should be lit with FREQ RANGE switch fully counterclockwise (500-1000 MHz).

Table 5-5. +20 Volt Supply Troubleshooting

Symptom	Procedure	Indication	Conclusion
High Output Voltage	1. Disconnect base of Q1	Output drops	Q1 ok
		Output same	Q1 shorted
	2. Reconnect base of Q1. Measure voltage across A16CR3	Approximately 3.5V	A16CR3 ok
		More than approximately 3.5V	A16CR3 open
	3. Short emitter to base A16Q1	Output drops	A16Q1 ok
		Output same	A16Q1 shorted
	4. Measure voltage across A16CR7	Approximately 6.5V	A16CR7 ok
		More than approximately 6.5V	A16CR7 open
	5. Adjust A16R11 so base of A16Q3 goes more negative	Output remains high	A16Q3 open
		Output lowers but still high	A16Q3 gain too low
Low Output Voltage	1. Measure voltage across A16CR3	Approximately 3.5V	A16CR3 ok
		Less than approximately 3.5V	A16CR3 shorted
	2. Short emitter to collector A16Q1	Output rises	Q1 ok
		Output same	Q1 open
	3. Measure voltage across A16CR7	Approximately 6.5V	A16CR7 ok
		Less than approximately 6.5V	A16CR7 shorted
	4. Measure voltage at collector of A16Q3	Approximately 6.5V (same as A16CR7)	A16Q3 shorted
	5. Measure voltage at collector of A16Q2	Same as voltage at emitter	A16Q2 shorted
		Lower than A16Q2 emitter voltage	A16Q2 ok
	High Ripple	1. Measure ripple at base of A16Q3	No ripple
2. Measure ripple at base of A16Q1		No ripple	A16Q3 open
3. Measure ripple at base of Q1		No ripple	A16Q1 open

Table 5-6. -20 Volt Supply Troubleshooting

Symptom	Procedure	Indication	Conclusion
High Output Voltage	1. Disconnect base of Q2	Output drops	Q2 ok
		Output same	Q2 shorted
	2. Reconnect base of Q2 Measure voltage across A16CR10	Approximately 3.5V	A16CR10 ok
		More than approximately 3.5V	A16CR10 open
	3. Short emitter to base A16Q4	Output drops	A16Q4 ok
		Output same	A16Q4 shorted
	4. Measure voltage across A16CR14	Approximately 6.1V	A16CR14 ok
		More than approximately 6.1 V	A16CR14 open
	5. Adjust A16R23 so base of A16Q6 goes more negative	Output remains high	A16Q6 open
		Output lower but still high	A16Q6 gain too low
Low Output Voltage	1. Measure voltage across A16CR10	Approximately 3.5V	A16CR10 ok
		Less than approximately 3.5V	A16CR10 shorted
	2. Short emitter to collector A16Q4	Output rises	Q2 ok
		Output same	Q2 open
	3. Measure voltage across A16CR14	Approximately 6.1V	A16CR14 ok
		Less than approximately 6.1V	A16CR14 shorted
	4. Measure voltage at collector of A16Q6	Approximately 6.1V (same as A16CR14)	A16Q6 shorted
	5. Measure voltage at collector of A16Q5.	Same as voltage at emitter	A16Q5 shorted
		Lower than A16Q2 emitter voltage	A16Q5 ok
	High Ripple	1. Measure ripple at base of A16Q6	No ripple
2. Measure ripple at base of A16Q4		No ripple	A16Q6 open
3. Measure ripple at base of Q2		No ripple	A16Q4 open

Table 5-7. Phase Meter Circuit Troubleshooting

Symptom (See Note 1)	Procedure (See Note 2)	Indication	Conclusion
Meter Pegs + and - 180° As ZERO control is adjusted	1. Check trigger pulses at bases of A8Q9 and A8Q10	Pulses are arriving simultaneously	Phase Inverter, A6Q2-4 is defective
		Pulses are not arriving simultaneously	OFFSET switch, A21, is defective
Meter Pegs +180° regard- less of ZERO control. Setting NOTE: -20 Volt DC supply may be missing	1. Check waveform at collector at A8Q9.	Symmetrical square wave present	Switch A8Q11-12 or Current Source A8Q13-15 is defective
		2. Check for trigger pulses at base of A8Q10	Trigger pulses present
	3. Check for square wave at XA8 (Pin 1).	Square wave at XA8 (Pin 1) and pulses at collector of A8Q1	Driver, A8Q7 is defective
		Square wave at XA8 (Pin 1) but no pulses at collector of A8Q1	Amplifier, A8Q1, or Switch A8Q2-3 is defective
	4. Check for square wave at XA7 (Pin 1)	No square wave	Limiter, A5Q4, A5Q5, or A5Q6 is defective
		XA7 (Pin 1) square wave and sine wave at A7Q2 collector	Limiter A7Q5-6 is defective
		Square waves at XA7 (Pin 1) and A7Q1 collector but no sine wave at A7Q2 collector	Phase shifter A7Q2-4 is defective
		Square wave at XA7 (Pin 1) but not A7Q1 collector	A7Q1 is defective
Meter Pegs -180° regard- less of ZERO control setting NOTE: +20 volts DC supply may be missing	1. Check waveform at A8Q9 collector	Symmetrical square wave present	Switch A8Q11-12, or Current Source A8Q16-19, or OFFSET switch is defective
	2. Check for trigger pulses at A8Q9 base	Trigger pulses present	Multivibrator A8Q9- 10 is defective
	3. Check for square wave at XA8 (Pin 15)	Square wave at XA8 (Pin 15) and pulses at A8Q4 collector	A8Q8 is defective
Square wave but no pulses at A8Q4 collector		A8Q4 or A8Q5-6 is defective	

Table 5-7. Phase Meter Circuit Troubleshooting (Cont'd)

Symptom (See Note 1)	Procedure (See Note 2)	Indication	Conclusion
	4. Check for square wave at XA6 (Pin 1)	No square wave	A18Q4, A18Q5, or A18Q6 is defective
		XA6 (Pin 1) Square wave and sine wave at A6Q4 collector	Limiter A6Q5-6 is defective
		Square wave at XA6 (Pin 1) and A6Q1 collector but no sine wave at A6Q4 collector	Phase Inverter A6Q2-4 is defective
		Square wave at XA6 (Pin 1) but not A6Q1 collector	A6Q1 is defective
Meter needle, using ZERO control, is adjustable but not symmetrically about 0°	1. Check waveform at A8Q9 collector	Symmetrical Square wave	Phase meter section out of adjustment: Refer to adjustment procedure, Section V.
		Square wave not symmetrical	Phase Inverter A6Q2-4 or Phase Shifter A7Q2-4 is defective
No meter movement, meter reads 0°	1. Remove 8405A power cord and connect ohmmeter across phase meter terminals	No meter deflection	Defective meter
		Meter deflection	One or both wires connecting meter to circuitry must be broken.
Phase meter trouble exists only for OFFSET settings from -90° to -180° and +100° to +180° (See Note 3)	1. Set OFFSET switch to any setting between -90° and -180° or +100° and +180° and measure DC voltage at A6 (Pin 8)	0 volts at A6 (Pin 8)	Phase inverter A6Q3-4 is defective
		+20 volts at A6 (Pin 8)	The section of OFFSET switch A21S1A/B which operates A6Q2-3 is defective
NOTES:	<ol style="list-style-type: none"> 1. Test setup and 8405A control settings are same as for front panel troubleshooting Table 5-4. 2. All sine waves and square waves are 20 kHz; pulses have 20 kHz repetition rates. 3. The Phase Meter Offset control is intended for use ONLY when a definite phase angle exists between the two input probes. Misuse of the Offset control makes a good 8405A appear bad. For example, with an input phase angle of 0°, setting the Offset control between +100 and +180 or between -90 and -180 will cause the Phase Meter to "peg", this is entirely normal. 		

Table 5-8. Channel A and APC Troubleshooting

Symptom (Note 1)	Procedure	Indication	Conclusion
APC lamp does not light with FREQ RANGE switch set to 500-1000 MHz	1. Check for -20 volts DC at XA12 (Pin 11)	No -20 Volts DC	Rear panel -20V fuse or -20 Volt Power Supply is defective (Table 5-6)
	2. Check for 20 MHz oscillator signal at XA12 (Pin 10)	No 20 MHz Signal	Reference Oscillator A11Q4-5 is defective
	3. Check for -15 volts DC at XA12 (Pin 7)	No -15 volts DC	Lamp driver A12Q6 is defective
		-15 volts DC ok	APC unlocked lamp is defective
APC lamp remains lit with switch set to 1-4 MHz	1. Check for +20 volts DC at XA12 (Pin 12)	No +20 volts DC	Rear panel +20V fuse or +20 V Power Supply is defective (Table 5-5)
	2. Change Signal Source Frequency and 8405A FREQ RANGE switch to about 8-10 MHz.	APC Lamp goes out and meters indicate readings	A13 Assy is defective (Probably bad capacitor or changed value resistor), or FREQ RANGE switch A24S1 is defective.
	3. Remove Probe A circuit board Assy from probe cable socket and replace with Probe B circuit board Assy.	APC lamp goes out and meters indicate readings.	Probe A circuit board assembly is defective.
	4. Remove Probe board from cable assembly. Turn 8405A off and check cable for open-circuits.		
	5. Replace Probe A board assembly in cable assembly. Check for search ramp at XA12 - Pin 1.	Ramp signal as shown opposite page 7-15.	A14 Assembly, A15 Assembly, A24S1 FREQ RANGE switch or A19 Decoupling Diode is defective.
<p>NOTE:</p> <ol style="list-style-type: none"> 1. Test setup and 8405A control settings are same as for Table 5-4. 2. If a probe board is replaced, the Adjustment Procedure Table 5-3 must be done. Remove board only after some indication that the probe is faulty. To remove board remove setscrew marked "Do not remove this screw" in Fig. 7-5. To replace board be sure key on plug is aligned with key on socket. 			

Table 5-9. Channel B Circuit Troubleshooting

Sympton (See Note 1)	Procedure	Indication	Conclusion
CHANNEL B IF OUTPUT waveform is a 20 kHz sine wave of about 10 mV rms (28 mV pk-pk)	1. Isolate trouble within IF amplifier A18Q1-3 by CHANNEL B IF TUNING AND GAIN Adjustment procedure (Table 5-3 part 3B).		IF Amplifier A18Q1-3 is defective.
CHANNEL B IF OUTPUT is much less than 10 mV or there is no output	1. Check for pulse output at XA4-Pin 4 (Compare with pulses at XA3-Pin 4). These two pictures should look the same.	No Pulses	Resistor A15R2, or A17 Delay line, A19 or A20 Decoupling Diode Assy is defective
		Pulses ok	Probe B amplifier A2A1Q1 or A4 Assy Amplifier A4Q1 is defective
	Pulses much larger than those at CHANNEL A probe tip.	Probe B diodes, or Amplifier A4Q2 defective	
	Pulses very small (or no pulses at all)	Probe B Circuit Assy, probe cable, or A4T1 defective, -or- A4 Assy out of adjustment. Refer to PULSE generator and sampler adjust Table 5-3	
	3. Remove Probe B circuit board Assy from its socket. Replace Probe A circuit board Assy in Channel A cable with Probe B circuit board Assy. Repeat step 2 above to determine if Probe B circuit board is defective	Pulses ok	Probe B circuit board Assy ok
Pulses too large, too small, or no pulses at all		Probe B circuit board Assy defective	

NOTE:

1. TEST Setup and 8405A control settings are same as for Table 5-4.

SECTION VI REPLACEABLE PARTS

6-1. INTRODUCTION.

6-2. This section contains information for ordering replacement parts. Table 6-1 lists parts in alpha-numerical order of their reference designations and indicates the description and HP stock number of each part, together with any applicable notes. Table 6-2 lists parts in alpha-numerical order of their HP stock number and provides the following information on each part:

- a. Description of the part (see list of abbreviations below).
- b. Typical manufacturer of the part in a five-digit code; see list of manufacturers in Table 6-3.
- c. Manufacturer's part number.
- d. Total quantity used in the instrument (TQ column).

6-3. Miscellaneous parts are listed at the end of Table 6-1.

6-4. ORDERING INFORMATION.

6-5. To obtain replacement parts, address order or inquiry to your local Hewlett-Packard sales and service office (see lists at rear of this manual). Identify parts by Hewlett-Packard stock number.

6-6. To obtain a part not listed, include:

- a. Instrument model number
- b. Instrument serial number
- c. Description of part
- d. Function and location of part.

REFERENCE DESIGNATORS

A	= assembly	F	= fuse	MP	= mechanical part	V	= vacuum, tube, neon bulb, photocell, etc.
B	= motor	FL	= filter	P	= plug	VR	= voltage regulator
BT	= battery	IC	= integrated circuit	Q	= transistor	W	= cable
C	= capacitor	J	= jack	R	= resistor	X	= socket
CP	= coupler	K	= relay	RT	= thermistor	Y	= crystal
CR	= diode	L	= inductor	S	= switch	Z	= tuned cavity, network
DL	= delay line	LS	= loud speaker	T	= transformer		
DS	= device signaling (lamp)	M	= meter	TB	= terminal board		
E	= misc electronic part	MK	= microphone	TP	= test point		

ABBREVIATIONS

A	= amperes	H	= henries	N/O	= normally open	RMO	= rack mount only
AFC	= automatic frequency control	HDW	= hardware	NPO	= negative positive zero (zero temperature coefficient)	RMS	= root-mean square
AMPL	= amplifier	HEX	= hexagonal			RWV	= reverse working voltage
BFO	= beat frequency oscillator	HG	= mercury	NPN	= negative-positive-negative	S-B	= slow-blow
BE CU	= beryllium copper	HR	= hour(s)	NRFR	= not recommended for field replacement	SCR	= screw
BH	= binder head	HZ	= hertz	NSR	= not separately replaceable	SE	= selenium
BP	= bandpass	IF	= intermediate freq			SECT	= section(s)
BRS	= brass	IMPG	= impregnated			SEMICON	= semiconductor
BWO	= backward wave oscillator	INCD	= incandescent			SI	= silicon
CCW	= counter-clockwise	INCL	= include(s)	OBD	= order by description	SIL	= silver
CER	= ceramic	INS	= insulation(ed)	OH	= oval head	SL	= slide
CMO	= cabinet mount only	INT	= internal	OX	= oxide	SPG	= spring
COEF	= coefficient	K	= kilo = 1000			SPL	= special
COM	= common	LH	= left hand	P	= peak	SST	= stainless steel
COMP	= composition	LN	= linear taper	PC	= printed circuit	SR	= split ring
COMPL	= complete	LK WASH	= lock washer	PF	= picofarads = 10 ⁻¹² farads	STL	= steel
CONN	= connector	LOG	= logarithmic taper	PH BRZ	= phosphor bronze	TA	= tantalum
CP	= cadmium plate	LPF	= low pass filter	PHL	= Phillips	TD	= time delay
CRT	= cathode-ray tube			PIV	= peak inverse voltage	TGL	= toggle
CW	= clockwise	M	= milli = 10 ⁻³	PNP	= positive-negative-positive	THD	= thread
DEPC	= deposited carbon	MEG	= meg = 10 ⁶	P/O	= part of	TI	= titanium
DR	= drive	MET FLM	= metal film	POLY	= polystyrene	TOL	= tolerance
ELECT	= electrolytic	MET OX	= metallic oxide	PORC	= porcelain	TRIM	= trimmer
ENCAP	= encapsulated	MFR	= manufacturer	POS	= position(s)	TWT	= traveling wave tube
EXT	= external	MHZ	= mega hertz	POT	= potentiometer	U	= micro = 10 ⁻⁶
F	= farads	MINAT	= miniature	PP	= peak-to-peak	VAR	= variable
FH	= flat head	MOM	= momentary	PT	= point	VDCW	= dc working volts
FIL H	= fillister head	MTG	= mounting	PWV	= peak working voltage	W/	= with
FXD	= fixed	MY	= "mylar"	RECT	= rectifier	W	= watts
G	= giga (10 ⁹)	N	= nano (10 ⁻⁹)	RF	= radio frequency	WIV	= working inverse voltage
GE	= germanium	N/C	= normally closed	RH	= round head or right hand	WW	= wirewound
GL	= glass	NE	= neon			W/O	= without
GRD	= ground(ed)	NI PL	= nickel plate				

Table 6-1. Reference Designation Index

Reference Designation	Part No.	Description #	Note
A1MP1	5020-0457	PROBE TIP	
A1MF2	00187-42106 08405-6055	RING:IDENT BLUE HOUSING ASSY:PROBE	
A1W1	08405-6047	CABLE ASSY:SPECIAL COAX INCL PROBE & PANEL BOOT & BD ASSY SOCKET	
A1A1	08405-6054	BOARD ASSY:PROBE NOT RECOMMENDED FOR FIELD REPLACEMENT	
A2MP1	08405-2032	RING:IDENT WHITE	
A2MF2	08405-6055	HOUSING ASSY:PROBE	
A2W1	08405-6047	CABLE ASSY:SPECIAL COAX INCL PROBE & PANEL BOOT & BD ASSY SOCKET	
A2A1	08405-6054	BOARD ASSY:PROBE NOT RECOMMENDED FOR FIELD REPLACEMENT	
A2A1MP1	5020-0457	PROBE TIP	
A3	08405-6002	BOARD ASSY:SAMPLER	
A3C1	0180-0100	C:FXD ELECT 4.7 UF 10% 35VDCW	
A3C2	0140-0194	C:FXD MICA 110 PF 5%	
A3C3	0180-0374	C:FXD ELECT 10 UF 10% 20VDCW	
A3C4	0180-0374	C:FXD ELECT 10 UF 10% 20VDCW	
A3C5	0180-0374	C:FXD ELECT 10 UF 10% 20VDCW	
A3C6	0180-0100	C:FXD ELECT 4.7 UF 10% 35VDCW	
A3C7	0160-2055	C:FXD CER 0.01 UF +80-20% 100VDCW	
A3C8	0160-0174	C:FXD CER 0.47 UF +80-20% 25VDCW	
A3C9	0160-0174	C:FXD CER 0.47 UF +80-20% 25VDCW	
A3C10	0160-2139	C:FXD CER 220 PF +80-20% 1000VDCW	
A3C11	0160-2139	C:FXD CER 220 PF +80-20% 1000VDCW	
A3C12	0160-2139	C:FXD CER 220 PF +80-20% 1000VDCW	
A3C13	0160-2139	C:FXD CER 220 PF +80-20% 1000VDCW	
A3Q1	1854-0071	TRANSISTOR:SILICON NPN	
A3Q2	1854-0071	TRANSISTOR:SILICON NPN	
A3R1	0757-0279	R:FXD MET FLM 3.16K OHM 1% 1/8W	
A3R2	0757-0279	R:FXD MET FLM 3.16K OHM 1% 1/8W	
A3R3	0757-0424	R:FXD MET FLM 1.10K OHM 1% 1/8W	
A3R4	0698-3155	R:FXD MET FLM 4.64K OHM 1% 1/8W	
A3R5	2100-1757	R:VAR WW 500 OHM 5% 1W	
A3R6	0698-3157	R:FXD MET FLM 19.6K OHM 1% 1/8W	
A3R7	0698-3157	R:FXD MET FLM 19.6K OHM 1% 1/8W	
A3R8	0698-3438	R:FXD MET FLM 147 OHM 1% 1/8W	
A3R9	0757-0279	R:FXD MET FLM 3.16K OHM 1% 1/8W	
A3R10	0757-0438	R:FXD MET FLM 5.11K OHM 1% 1/8W	

See introduction to this section for ordering information

Table 6-1. Reference Designation Index (Cont'd)

Reference Designation	Part No.	Description #	Note
A3R11	0757-1078	R:FXD MET FLM 1.47K OHM 1% 1/2W	
A3R12	0757-0401	R:FXD MET FLM 100 OHM 1% 1/8W	
A3R13	0698-3407	R:FXD MET FLM 1.96K OHM 1% 1/2W	
A3R14	0757-0440	R:FXD MET FLM 7.50K OHM 1% 1/8W	
A3R15	2100-1761	R:VAR WW 10K OHM 5% 1W	
A3R16	0698-3150	R:FXD MET FLM 2.37K OHM 1% 1/8W	
A3R17	0698-3157	R:FXD MET FLM 19.6K OHM 1% 1/8W	
A3R18	0698-3157	R:FXD MET FLM 19.6K OHM 1% 1/8W	
A3R19	0698-3157	R:FXD MET FLM 19.6K OHM 1% 1/8W	
A3R20	2100-0942	R:VAR FLM 50K OHM 20% 3/4W	
A3R21	0757-0294	R:FXD MET FLM 17.8 OHM 1% 1/8W	
A3R22	0698-3437	R:FXD MET FLM 133 OHM 1% 1/8W	
A3R23	0698-3437	R:FXD MET FLM 133 OHM 1% 1/8W	
A3R24	0698-3437	R:FXD MET FLM 133 OHM 1% 1/8W	
A3R25	0698-3437	R:FXD MET FLM 133 OHM 1% 1/8W	
A3R26	0757-0294	R:FXD MET FLM 17.8 OHM 1% 1/8W	
A3R27		DELETED (REPLACED WITH A SHORT)	
A3T1	08405-8001	TRANSFORMER: BALUN	
A4	08405-6002	BOARD ASSY: SAMPLER	
A4C1	0180-0100	C:FXD ELECT 4.7 UF 10% 35VDCW	
A4C2	0140-0194	C:FXD MICA 110 PF 5%	
A4C3	0180-0374	C:FXD ELECT 10 UF 10% 20VDCW	
A4C4	0180-0374	C:FXD ELECT 10 UF 10% 20VDCW	
A4C5	0180-0374	C:FXD ELECT 10 UF 10% 20VDCW	
A4C6	0180-0100	C:FXD ELECT 4.7 UF 10% 35VDCW	
A4C7	0160-2055	C:FXD CER 0.01 UF +80-20% 100VDCW	
A4C8	0160-0174	C:FXD CER 0.47 UF +80-20% 25VDCW	
A4C9	0160-0174	C:FXD CER 0.47 UF +80-20% 25VDCW	
A4C10	0160-2139	C:FXD CER 220 PF +80-20% 1000VDCW	
A4C11	0160-2139	C:FXD CER 220 PF +80-20% 1000VDCW	
A4C12	0160-2139	C:FXD CER 220 PF +80-20% 1000VDCW	
A4C13	0160-2139	C:FXD CER 220 PF +80-20% 1000VDCW	
A4Q1	1854-0071	TRANSISTOR: SILICON NPN	
A4Q2	1854-0071	TRANSISTOR: SILICON NPN	
A4R1	0757-0279	R:FXD MET FLM 3.16K OHM 1% 1/8W	
A4R2	0757-0279	R:FXD MET FLM 3.16K OHM 1% 1/8W	
A4R3	0757-0424	R:FXD MET FLM 1.10K OHM 1% 1/8W	
A4R4	0698-3155	R:FXD MET FLM 4.64K OHM 1% 1/8W	
A4R5	2100-1757	R:VAR WW 500 OHM 5% 1W	
A4R6	0698-3157	R:FXD MET FLM 19.6K OHM 1% 1/8W	
A4R7	0698-3157	R:FXD MET FLM 19.6K OHM 1% 1/8W	
A4R8	0698-3438	R:FXD MET FLM 147 OHM 1% 1/8W	
A4R9	0757-0279	R:FXD MET FLM 3.16K OHM 1% 1/8W	
A4R10	0757-0438	R:FXD MET FLM 5.11K OHM 1% 1/8W	

See introduction to this section for ordering information

Table 6-1. Reference Designation Index (Cont'd)

Reference Designation	Part No.	Description #	Note
A4R11	0757-1078	R:FXD MET FLM 1.47K OHM 1% 1/2W	
A4R12	0757-0401	R:FXD MET FLM 100 OHM 1% 1/8W	
A4R13	0698-3407	R:FXD MET FLM 1.96K OHM 1% 1/2W	
A4R14	0757-0440	R:FXD MET FLM 7.50K OHM 1% 1/8W	
A4R15	2100-1761	R:VAR WW 10K OHM 5% 1W	
A4R16	0698-3150	R:FXD MET FLM 2.37K OHM 1% 1/8W	
A4R17	0698-3157	R:FXD MET FLM 19.6K OHM 1% 1/8W	
A4R18	0698-3157	R:FXD MET FLM 19.6K OHM 1% 1/8W	
A4R19	0698-3157	R:FXD FLM 19.6K OHM 1% 1/8W	
A4R20	2100-0942	R:VAR FLM 50K OHM 20% 3/4W	
A4R21	0757-0294	R:FXD MET FLM 17.8 OHM 1% 1/8W	
A4R22	0698-3437	R:FXD MET FLM 133 OHM 1% 1/8W	
A4R23	0698-3437	R:FXD MET FLM 133 OHM 1% 1/8W	
A4R24	0698-3437	R:FXD MET FLM 133 OHM 1% 1/8W	
A4R25	0698-3437	R:FXD MET FLM 133 OHM 1% 1/8W	
A4R26	0757-0294	R:FXD MET FLM 17.8 OHM 1% 1/8W	
A4R27		DELETED (REPLACED WITH A SHORT)	
A4T1	08405-8001	TRANSFORMER: BALUN	
A5	08405-6003	BOARD ASSY: ISOLATION AMP.	
A5C1	0180-0100	C:FXD ELECT 4.7 UF 10% 35VDCW	
A5C2	0150-0121	C:FXD CER 0.1 UF +80-20% 50VDCW	
A5C3	0180-0137	C:FXD ELECT 100 UF 20% 10VDCW	
A5C4	0160-2120	C:FXD MICA 0.01UF 1%	
A5C5	0180-0100	C:FXD ELECT 4.7 UF 10% 35VDCW	
A5C6	0180-0100	C:FXD ELECT 4.7 UF 10% 35VDCW	
A5C7	0180-2071	C:FXD ELECT 0.022 UF 10% 35VDCW	
A5C8	0180-0100	C:FXD ELECT 4.7 UF 10% 35VDCW	
A5C9	0180-0100	C:FXD ELECT 4.7 UF 10% 35VDCW	
A5C10	0180-0100	C:FXD ELECT 4.7 UF 10% 35VDCW	
A5C11	0180-0100	C:FXD ELECT 4.7 UF 10% 35VDCW	
A5C12	0180-0100	C:FXD ELECT 4.7 UF 10% 35VDCW	
A5C13	0180-0100	C:FXD ELECT 4.7 UF 10% 35VDCW	
A5C14	0180-0100	C:FXD ELECT 4.7 UF 10% 35VDCW	
A5C15	0180-0100	C:FXD ELECT 4.7 UF 10% 35VDCW	
A5C16	0160-2143	C:FXD CER 2000 PF +80-20% 100VDCW	
A5C17	0160-2261	C:FXD CER 15 PF 5% 50VDCW	
A5CR1	08405-8004	DIODES: SILICON MATCHED PAIR	
A5CR2		PART OF A5CR1	
A5L1	9100-1719	COIL:VAR	
A5L2	9140-0114	COIL:FXD RF 10 UH	
A5MP1	5020-2045	CARD EXTRACTOR	

See introduction to this section for ordering information

Table 6-1. Reference Designation Index (Cont'd)

Reference Designation	Part No.	Description #	Note
A5Q1	1854-0071	TRANSISTOR:SILICON NPN	
A5Q2	1854-0071	TRANSISTOR:SILICON NPN	
A5Q3	1854-0071	TRANSISTOR:SILICON NPN	
A5Q4	1854-0071	TRANSISTOR:SILICON NPN	
A5Q5	1854-0071	TRANSISTOR:SILICON NPN	
A5Q6	1854-0071	TRANSISTOR:SILICON NPN	
A5R1	0757-0459	R:FXD MET FLM 56.2K OHM 1% 1/8W	
A5R2	0698-3157	R:FXD MET FLM 19.6K OHM 1% 1/8W	
A5R3	0698-3157	R:FXD MET FLM 19.6K OHM 1% 1/8W	
A5R4	0757-0442	R:FXD MET FLM 10.0K OHM 1% 1/8W	
A5R5	0698-3160	R:FXD MET FLM 31.6K OHM 1% 1/8W	
A5R6	0757-0280	R:FXD MET FLM 1K OHM 1% 1/8W	
A5R7	0757-0444	R:FXD MET FLM 12.1K OHM 1% 1/8W	
A5R8	0698-0083	R:FXD MET FLM 1.96K OHM 1% 1/8W	
A5R9		NOT ASSIGNED	
A5R10	0757-0442	R:FXD MET FLM 10.0K OHM 1% 1/8W	
A5R11	2100-1760	R:VAR WW 5K OHM 5% 1W	
A5R12	0757-0447	R:FXD MET FLM 16.2K OHM 1% 1/8W	
A5R13	0757-0278	R:FXD MET FLM 1.78K OHM 1% 1/8W	
A5R14	0757-0428	R:FXD MET FLM 1.62K OHM 1% 1/8W	
A5R15	0757-0428	R:FXD MET FLM 1.62K OHM 1% 1/8W	
A5R16	0757-0288	R:FXD MET FLM 9.09K OHM 1% 1/8W	
A5R17	0757-0438	R:FXD MET FLM 5.11K OHM 1% 1/8W	
A5R18	0757-0280	R:FXD MET FLM 1K OHM 1% 1/8W	
A5R19	0757-0394	R:FXD MET FLM 51.1 OHM 1% 1/8W	
A5R20	0698-3444	R:FXD MET FLM 316 OHM 1% 1/8W	
A5R21	0757-0280	R:FXD MET FLM 1K OHM 1% 1/8W	
A5R22	0698-3441	R:FXD MET FLM 215 OHM 1% 1/8W	
A5R23	0698-3153	R:FXD MET FLM 3.83K OHM 1% 1/8W	
A5R24	0757-0439	R:FXD MET FLM 6.81K OHM 1% 1/8W	
A5R25	0698-0082	R:FXD MET FLM 464 OHM 1% 1/8W	
A5R26	0698-3155	R:FXD MET FLM 4.64K OHM 1% 1/8W	
A5R27	0698-3136	R:FXD MET FLM 17.8K OHM 1% 1/8W	
A5R28	0698-3406	R:FXD MET FLM 1.33K OHM 1% 1/2W	
A5R29	0698-3438	R:FXD MET FLM 147 OHM 1% 1/8W	
A5R30	0698-0084	R:FXD MET FLM 2.15K OHM 1% 1/8W	
A6	08405-6006	BOARD ASSY:180 DEG. SWITCH	
A6C1	0180-0100	C:FXD ELECT 4.7 UF 10% 35VDCW	
A6C2	0180-0100	C:FXD ELECT 4.7 UF 10% 35VDCW	
A6C3	0180-0100	C:FXD ELECT 4.7 UF 10% 35VDCW	
A6C4	0140-0235	C:FXD MICA 2250PF 1% 300VDCW	
A6C5	0180-0100	C:FXD ELECT 4.7 UF 10% 35VDCW	
A6C6	0180-0100	C:FXD ELECT 4.7 UF 10% 35VDCW	
A6C7	0180-0100	C:FXD ELECT 4.7 UF 10% 35VDCW	
A6C8	0180-0100	C:FXD ELECT 4.7 UF 10% 35VDCW	
A6C9	0180-0100	C:FXD ELECT 4.7 UF 10% 35VDCW	
A6C10	0180-0100	C:FXD ELECT 4.7 UF 10% 35VDCW	

See introduction to this section for ordering information

Table 6-1. Reference Designation Index (Cont'd)

Reference Designation	Part No.	Description #	Note
A6C11	0160-2120	C:FXD NICA 0.01UF 1%	
A6C12	0180-0100	C:FXD ELECT 4.7 UF 10% 35VDCW	
A6C13	0180-0100	C:FXD ELECT 4.7 UF 10% 35VDCW	
A6C14	0180-0100	C:FXD ELECT 4.7 UF 10% 35VDCW	
A6C15	0180-0100	C:FXD ELECT 4.7 UF 10% 35VDCW	
A6C16	0180-0100	C:FXD ELECT 4.7 UF 10% 35VDCW	
A6C17	0180-0100	C:FXD ELECT 4.7 UF 10% 35VDCW	
A6C18	0160-2261	C:FXD CER 15 PF 5% 500VDCW	
A6C19	0160-2261	C:FXD CER 15 PF 5% 500VDCW	
A6C20	0160-2261	C:FXD CER 15 PF 5% 500VDCW	
A6CR1	08405-8004	DIODES:SILICON MATCHED PAIR	
A6CR2		PART OF A6CR1	
A6CR3	1901-0040	DIODE:SILICON 30MA 30WV	
A6CR4	1901-0040	DIODE:SILICON 30MA 30WV	
A6L1	9100-1718	COIL:VAR	
A6MP1	5020-2045	GARD EXTRACTOR	
A6Q1	1854-0071	TRANSISTOR:SILICON NPN	
A6Q2	1854-0071	TRANSISTOR:SILICON NPN	
A6Q3	1854-0071	TRANSISTOR:SILICON NPN	
A6Q4	1854-0071	TRANSISTOR:SILICON NPN	
A6Q5	1854-0071	TRANSISTOR:SILICON NPN	
A6Q6	1854-0071	TRANSISTOR:SILICON NPN	
A6R1	0698-0082	R:FXD MET FLM 464 OHM 1% 1/8W	
A6R2	0698-3155	R:FXD MET FLM 4.64K OHM 1% 1/8W	
A6R3	0698-3136	R:FXD MET FLM 17.8K OHM 1% 1/8W	
A6R4	0698-3406	R:FXD MET FLM 1.33K OHM 1% 1/2W	
A6R5	0698-3438	R:FXD MET FLM 147 OHM 1% 1/8W	
A6R6	0757-0289	R:FXD MET FLM 13.3K OHM 1% 1/8W	
A6R7	0757-0439	R:FXD MET FLM 6.81K OHM 1% 1/8W	
A6R8	0757-0200	R:FXD MET FLM 5.62K OHM 1% 1/8W	
A6R9	0757-1094	R:FXD MET FLM 1.47K OHM 1% 1/8W	
A6R10	0757-0123	R:FXD MET FLM 34.8K OHM 1% 1/8W	
A6R11	0757-0420	R:FXD MET FLM 750 OHM 1% 1/8W	
A6R12	0698-3153	R:FXD MET FLM 3.83K OHM 1% 1/8W	
A6R13	0757-0465	R:FXD MET FLM 100K OHM 1% 1/8W	
A6R14	0698-3161	R:FXD MET FLM 38.3K OHM 1% 1/8W	
A6R15	0698-3159	R:FXD MET FLM 26.1K OHM 1% 1/8W	
A6R16	0757-0199	R:FXD MET FLM 21.5K OHM 1% 1/8W	
A6R17	0757-0199	R:FXD MET FLM 21.5K OHM 1% 1/8W	
A6R18	0698-3162	R:FXD MET FLM 46.4K OHM 1% 1/8W	
A6R19	0757-0466	R:FXD MET FLM 110K OHM 1% 1/8W	
A6R20	0698-3153	R:FXD MET FLM 3.83K OHM 1% 1/8W	
A6R21	0698-3153	R:FXD MET FLM 3.83K OHM 1% 1/8W	
A6R22	0757-0200	R:FXD MET FLM 5.62K OHM 1% 1/8W	
A6R23	0698-0083	R:FXD MET FLM 1.96K OHM 1% 1/8W	
A6R24	0757-0466	R:FXD MET FLM 110K OHM 1% 1/8W	
A6R25	0698-3162	R:FXD MET FLM 46.4K OHM 1% 1/8W	

See introduction to this section for ordering information

Table 6-1. Reference Designation Index (Cont'd)

Reference Designation	Part No.	Description #	Note
A6R26	0698-0084	R:FXD MET FLM 2.15K OHM 1% 1/8W	
A6R27	0698-3449	R:FXD MET FLM 28.7K OHM 1% 1/8W	
A6R28	0698-3440	R:FXD MET FLM 196 OHM 1% 1/8W	
A6R29	0757-0401	R:FXD MET FLM 100 OHM 1% 1/8W	
A6R30	0698-3440	R:FXD MET FLM 196 OHM 1% 1/8W	
A7	08405-6005	BOARD ASSY:PHASE SWIFTER	
A7C1	0180-0100	C:FXD ELECT 4.7 UF 10% 35VDCW	
A7C2	0180-0100	C:FXD ELECT 4.7 UF 10% 35VDCW	
A7C3	0180-0100	C:FXD ELECT 4.7 UF 10% 35VDCW	
A7C4	0180-0100	C:FXD ELECT 4.7 UF 10% 35VDCW	
A7C5	0180-0100	C:FXD ELECT 4.7 UF 10% 35VDCW	
A7C6	0160-2127	C:FXD MICA 4600 PF 1%	
A7C7	0160-2127	C:FXD MICA 4600 PF 1%	
A7C8	0160-2120	C:FXD MICA 0.01UF 1%	
A7C9	0180-0100	C:FXD ELECT 4.7 UF 10% 35VDCW	
A7C10	0180-0100	C:FXD ELECT 4.7 UF 10% 35VDCW	
A7C11	0180-0100	C:FXD ELECT 4.7 UF 10% 35VDCW	
A7C12	0180-0100	C:FXD ELECT 4.7 UF 10% 35VDCW	
A7C13	0180-0100	C:FXD ELECT 4.7 UF 10% 35VDCW	
A7C14	0180-0100	C:FXD ELECT 4.7 UF 10% 35VDCW	
A7C15	0180-0100	C:FXD ELECT 4.7 UF 10% 35VDCW	
A7C16	0180-0100	C:FXD ELECT 4.7 UF 10% 35VDCW	
A7C17	0180-0100	C:FXD ELECT 4.7 UF 10% 35VDCW	
A7C18	0160-2261	C:FXD CER 15 PF 5% 500VDCW	
A7C19	0160-2261	C:FXD CER 15 PF 5% 500VDCW	
A7CR1	08405-8004	DIODES:SILICON MATCHED PAIR	
A7CR2		PART OF A7CR1	
A7CR3	1902-0025	DIODE,BREAKDOWN:10.0V 5% 400 MW	
A7L1	9100-1718	COIL:VAR	
A7MP1	5020-2045	CARD EXTRACTOR	
A7Q1	1854-0071	TRANSISTOR:SILICON NPN	
A7Q2	1854-0071	TRANSISTOR:SILICON NPN	
A7Q3	1854-0071	TRANSISTOR:SILICON NPN	
A7Q4	1854-0071	TRANSISTOR:SILICON NPN	
A7Q5	1854-0071	TRANSISTOR:SILICON NPN	
A7Q6	1854-0071	TRANSISTOR:SILICON NPN	
A7R1	0698-0082	R:FXD MET FLM 464 OHM 1% 1/8W	
A7R2	0698-3155	R:FXD MET FLM 4.64K OHM 1% 1/8W	
A7R3	0698-3136	R:FXD MET FLM 17.8K OHM 1% 1/8W	
A7R4	0698-3406	R:FXD MET FLM 1.33K OHM 1% 1/2W	
A7R5	0698-3438	R:FXD MET FLM 147 OHM 1% 1/8W	
A7R6	0698-0083	R:FXD MET FLM 1.96K OHM 1% 1/8W	

See introduction to this section for ordering information

Table 6-1. Reference Designation Index (Cont'd)

Reference Designation	Part No.	Description #	Note
A7R7	0757-0465	R:FXD MET FLM 100K OHM 1% 1/8W	
A7R8	0757-C280	R:FXD MET FLM 1K OHM 1% 1/8W	
A7R9	0757-0465	R:FXD MET FLM 100K OHM 1% 1/8W	
A7R10	0698-3151	R:FXD MET FLM 2.87K OHM 1% 1/8W	
A7R11	0757-1094	R:FXD MET FLM 1.47K OHM 1% 1/8W	
A7R12	0757-C199	R:FXD MET FLM 21.5K OHM 1% 1/8W	
A7R13	0757-0465	R:FXD MET FLM 100K OHM 1% 1/8W	
A7R14	0757-0465	R:FXD MET FLM 100K OHM 1% 1/8W	
A7R15	0698-3157	R:FXD MET FLM 19.6K OHM 1% 1/8W	
A7R16	0698-3442	R:FXD MET FLM 237 OHM 1% 1/8W	
A7R17	0698-0083	R:FXD MET FLM 1.96K OHM 1% 1/8W	
A7R18	0757-0466	R:FXD MET FLM 110K OHM 1% 1/8W	
A7R19	0698-3162	R:FXD MET FLM 46.4K OHM 1% 1/8W	
A7R20	0698-3153	R:FXD MET FLM 3.83K OHM 1% 1/8W	
A7R21	0757-1094	R:FXD MET FLM 1.47K OHM 1% 1/8W	
A7R22	0698-0085	R:FXD MET FLM 2.61K OHM 1% 1/8W	
A7R23	0698-3447	R:FXD MET FLM 422 OHM 1% 1/8W	
A7R24	0698-0083	R:FXD MET FLM 1.96K OHM 1% 1/8W	
A7R25	0698-3153	R:FXD MET FLM 3.83K OHM 1% 1/8W	
A7R26	0757-0200	R:FXD MET FLM 5.62K OHM 1% 1/8W	
A7R27	0757-0466	R:FXD MET FLM 110K OHM 1% 1/8W	
A7R28	0698-3162	R:FXD MET FLM 46.4K OHM 1% 1/8W	
A7R29	0698-0084	R:FXD MET FLM 2.15K OHM 1% 1/8W	
A7R30	0757-0441	R:FXD MET FLM 8.25K OHM 1% 1/8W	
A7R31	0698-3440	R:FXD MET FLM 196 OHM 1% 1/8W	
A7R32	0698-3440	R:FXD MET FLM 196 OHM 1% 1/8W	
A8	08405-6058	BOARD ASSY:PHASE METER	
A8C1	0150-0071	C:FXD CER 400 PF 5% 500VDCW	
A8C2	0140-0206	C:FXD MICA 270 PF 5%	
A8C3	0150-0071	C:FXD CER 400 PF 5% 500VDCW	
A8C4		NOT ASSIGNED	
A8C5	0140-0206	C:FXD MICA 270 PF 5%	
A8C6	0160-2055	C:FXD CER 0.01 UF +80-20% 100VDCW	
A8C7	0160-2055	C:FXD CER 0.01 UF +80-20% 100VDCW	
A8C8	0180-0100	C:FXD ELECT 4.7 UF 10% 35VDCW	
A8C9	0180-0098	C:FXD ELECT 100 UF 20% 20VDCW	
A8C10	0180-0100	C:FXD ELECT 4.7 UF 10% 35VDCW	
A8C11	0160-0127	C:FXD CER 1.0 UF 20% 25VDCW	
A8C12	0160-0127	C:FXD CER 1.0 UF 20% 25VDCW	
A8CR1	1901-0040	DIODE:SILICON 30MA 30WV	
A8CR2	1902-0018	DIODE BREAKDOWN:11.7V 5%	
A8CR3	1902-0018	DIODE BREAKDOWN:11.7V 5%	
A8CR4	1901-0040	DIODE:SILICON 30 MA 30WV	
A8CR5	1902-0048	DIODE BREAKDOWN:6.81V	
A8L1	9140-0120	COIL:FXD 0.1 UH 20%	
A8L2	9140-0120	COIL:FXD 0.1 UH 20%	

See introduction to this section for ordering information

Table 6-1. Reference Designation Index (Cont'd)

Reference Designation	Part No.	Description #	Note
A8L3	9140-0118	COIL:FXD 500 UH 5%	
A8L4	9140-0114	COIL:FXD RF 10 UH	
A8L5	9140-0114	COIL:FXD RF 10 UH	
A8MP1	5020-2045	CARD EXTRACTOR	
A8Q1	1853-0009	TRANSISTOR:SILICON PNP	
A8Q2	1853-0009	TRANSISTOR:SILICON PNP	
A8Q3	1854-0005	TRANSISTOR:SILICON NPN 2N708	
A8Q4	1853-0009	TRANSISTOR:SILICON PNP	
A8Q5	1853-0009	TRANSISTOR:SILICON PNP	
A8Q6	1854-0005	TRANSISTOR:SILICON NPN 2N708	
A8Q7	1854-0005	TRANSISTOR:SILICON NPN 2N708	
A8Q8	1854-0005	TRANSISTOR:SILICON NPN 2N708	
A8Q9	1854-0005	TRANSISTOR:SILICON NPN 2N708	
A8Q10	1854-0005	TRANSISTOR:SILICON NPN 2N708	
A8Q11	1854-0003	TRANSISTOR:PNP SILICON	
A8Q12	1854-0003	TRANSISTOR:PNP SILICON	
A8Q13	1854-0003	TRANSISTOR:PNP SILICON	
A8Q14	1854-0005	TRANSISTOR:SILICON NPN 2N708	
A8Q15	1205-0202	HEAT DISSIPATOR:SEMICONDUCTOR	
A8Q16	1853-0001	TRANSISTOR:PNP SILICON 30V 900MH	
A8Q17	1853-0001	TRANSISTOR:PNP SILICON 30V 900MH	
A8Q18	1853-0009	TRANSISTOR:SILICON PNP	
A8Q19	1205-0202	HEAT DISSIPATOR:SEMICONDUCTOR	
A8R1	0757-0442	R:FXD MET FLM 10.0K OHM 1% 1/8W	
A8R2	0757-1094	R:FXD MET FLM 1.47K OHM 1% 1/8W	
A8R3	0757-0280	R:FXD MET FLM 1K OHM 1% 1/8W	
A8R4	0698-3153	R:FXD MET FLM 3.83K OHM 1% 1/8W	
A8R5	0757-0123	R:FXD MET FLM 34.8K OHM 1% 1/8W	
A8R6	0698-3441	R:FXD MET FLM 215 OHM 1% 1/8W	
A8R7	0757-0442	R:FXD MET FLM 10.0K OHM 1% 1/8W	
A8R8	0757-1094	R:FXD MET FLM 1.47K OHM 1% 1/8W	
A8R9	0757-0280	R:FXD MET FLM 1K OHM 1% 1/8W	
A8R10	0698-3153	R:FXD MET FLM 3.83K OHM 1% 1/8W	
A8R11	0757-0123	R:FXD MET FLM 34.8K OHM 1% 1/8W	
A8R12	0698-3441	R:FXD MET FLM 215 OHM 1% 1/8W	
A8R13	0698-3445	R:FXD MET FLM 348 OHM 1% 1/8W	
A8R14	0698-3405	R:FXD MET FLM 422 OHM 1% 1/2W	
A8R15	0698-3405	R:FXD MET FLM 422 OHM 1% 1/2W	
A8R16	0757-0280	R:FXD MET FLM 1K OHM 1% 1/8W	
A8R17	0757-0280	R:FXD MET FLM 1K OHM 1% 1/8W	
A8R18	0698-3445	R:FXD MET FLM 348 OHM 1% 1/8W	
A8R19	0757-0405	R:FXD MET FLM 162 OHM 1% 1/8W	
A8R20	0757-0280	R:FXD MET FLM 1K OHM 1% 1/8W	

See introduction to this section for ordering information

Table 6-1. Reference Designation Index (Cont'd)

Reference Designation	Part No.	Description #	Note
A8R21	0698-3400	R:FXD MET FLM 147 OHM 1% 1/2W	
A8R22	0811-1637	R:FXD WW 344.3 OHM 0.1% 1/3W	
A8R23	0757-0462	R:FXD MET FLM 75.0K OHM 1% 1/8W	
A8R24	2100-1658	R:VAR WW 2K OHM 10% 1W	
A8R25	0811-1641	R:FXD WW 6710 OHM 0.1% 1/8W	
A8R26	0757-0405	R:FXD MET FLM 162 OHM 1% 1/8W	
A8R27	0698-3101	R:FXD MET FLM 2.87K OHM 1% 1/2W	
A8R28		NOT ASSIGNED	
A8R29	0811-1639	R:FXD WW 477.6 OHM 0.1% 1/8W	
A8R30	0757-0462	R:FXD MET FLM 75.0K OHM 1% 1/8W	
A8R31	0811-1641	R:FXD WW 6710 OHM 0.1% 1/8W	
A8R32	2100-1658	R:VAR WW 2K OHM 10% 1W	
A8R33	0757-0405	R:FXD MET FLM 162 OHM 1% 1/8W	
A8R34	0698-3101	R:FXD MET FLM 2.87K OHM 1% 1/2W	
A8R35		NOT ASSIGNED	
A8R36	0811-1642	R:FXD WW 8825 OHM 0.1% 1/8W	
A8R37	0757-0280	R:FXD MET FLM 1K OHM 1% 1/8W	
A8R38	0698-3153	R:FXD MET FLM 3.83K OHM 1% 1/8W	
A9	08405-6009	BOARD ASSY:VOLTMETER	
A9C1	0180-0100	C:FXD ELECT 4.7 UF 10% 35VDCW	
A9C2	0160-0301	C:FXD MY 0.012 UF 10% 200VDCW	
A9C3	0180-1735	C:FXD ELECT 0.22 UF 10% 35VDCW	
A9C4	0180-0100	C:FXD ELECT 4.7 UF 10% 35VDCW	
A9C5	0150-0121	C:FXD CER 0.1 UF +80-20% 50VDCW	
A9C6	0180-0100	C:FXD ELECT 4.7 UF 10% 35VDCW	
A9C7	0180-0098	C:FXD ELECT 100 UF 20% 20VDCW	
A9C8	0160-0164	C:FXD MY 0.039 UF 10% 200VDCW	
A9C9	0140-0180	C:FXD MICA 2000 PF 2%	
A9C10	0180-0100	C:FXD ELECT 4.7 UF 10% 35VDCW	
A9C11	0180-0137	C:FXD ELECT 100 UF 20% 10VDCW	
A9C12	0180-0100	C:FXD ELECT 4.7 UF 10% 35VDCW	
A9C13	0180-0100	C:FXD ELECT 4.7 UF 10% 35VDCW	
A9C14	0180-0100	C:FXD ELECT 4.7 UF 10% 35VDCW	
A9C15	0180-0100	C:FXD ELECT 4.7 UF 10% 35VDCW	
A9C16	0180-0100	C:FXD ELECT 4.7 UF 10% 35VDCW	
A9C17	0180-0100	C:FXD ELECT 4.7 UF 10% 35VDCW	
A9CR1	1901-0040	DIODE:SILICON 30MA 30WV	
A9CR2	1901-0040	DIODE:SILICON 30MA 30WV	
A9L1	9140-0072	COIL:RF 5000 UH 10%	
A9MF1	5020-2045	CARD EXTRACTOR	
A9Q1	1854-0071	TRANSISTOR:SILICON NPN	
A9Q2	1853-0020	TRANSISTOR:SILICON PNP	
A9Q3	1854-0071	TRANSISTOR:SILICON NPN	
A9Q4	1854-0071	TRANSISTOR:SILICON NPN	
A9Q5	1853-0020	TRANSISTOR:SILICON PNP	

See introduction to this section for ordering information

Table 6-1. Reference Designation Index (Cont'd)

Reference Designation	Part No.	Description #	Note
A9Q6	1854-0071	TRANSISTOR: SILICON NPN	
A9R1	0757-0289	R:FXD MET FLM 13.3K OHM 1% 1/8W	
A9R2	0757-0467	R:FXD MET FLM 121K OHM 1% 1/8W	
A9R3	0757-0459	R:FXD MET FLM 56.2K OHM 1% 1/8W	
A9R4	0757-0465	R:FXD MET FLM 100K OHM 1% 1/8W	
A9R5	0698-3162	R:FXD MET FLM 46.4K OHM 1% 1/8W	
A9R6	0757-0401	R:FXD MET FLM 100 OHM 1% 1/8W	
A9R7	0757-0442	R:FXD MET FLM 10.0K OHM 1% 1/8W	
A9R8	0757-0394	R:FXD MET FLM 51.1 OHM 1% 1/8W	
A9R9	0698-3156	R:FXD MET FLM 14.7K OHM 1% 1/8W	
A9R10	0757-0200	R:FXD MET FLM 5.62K OHM 1% 1/8W	
A9R11	0698-3132	R:FXD MET FLM 261 OHM 1% 1/8W	
A9R12	0698-0085	R:FXD MET FLM 2.61K OHM 1% 1/8W	
A9R13	0698-3162	R:FXD MET FLM 46.4K OHM 1% 1/8W	
A9R14	0698-3449	R:FXD MET FLM 28.7K OHM 1% 1/8W	
A9R15	0757-0444	R:FXD MET FLM 12.1K OHM 1% 1/8W	
A9R16	0757-0443	R:FXD MET FLM 11.0K OHM 1% 1/8W	
A9R17	0698-0085	R:FXD MET FLM 2.61K OHM 1% 1/8W	
A9R18	0757-0288	R:FXD MET FLM 9.09K OHM 1% 1/8W	
A9R19	0757-0402	R:FXD MET FLM 110 OHM 1% 1/8W	
A9R20	0757-0316	R:FXD MET FLM 42.2 OHM 1% 1/8W	
A9R21	0698-0085	R:FXD MET FLM 2.61K OHM 1% 1/8W	
A9R22	0698-3136	R:FXD MET FLM 17.8K OHM 1% 1/8W	
A9R23	0757-0424	R:FXD MET FLM 1.10K OHM 1% 1/8W	
A9R24	0757-0424	R:FXD MET FLM 1.10K OHM 1% 1/8W	
A9R25	0757-0833	R:FXD MET FLM 5.11K OHM 1% 1/2W	
A9R26	0757-0464	R:FXD MET FLM 90.9K OHM 1% 1/8W	
A9R27	0757-0274	R:FXD MET FLM 1.21K OHM 1% 1/8W	
A9R28	0757-0280	R:FXD MET FLM 1K OHM 1% 1/8W	

See introduction to this section for ordering information

Table 6-1. Reference Designation Index (Cont'd)

Reference Designation	Part No.	Description #	Note
A10	08405-6010	BOARD ASSY:APC AMPLIFIER	
A10C1	0160-2146	C:FXD CER 0.02 UF +80-20% 100VDCW	
A10C2	0180-0100	C:FXD ELECT 4.7 UF 10% 35VDCW	
A10C3	0180-0100	C:FXD ELECT 4.7 UF 10% 35VDCW	
A10C4	0180-0100	C:FXD ELECT 4.7 UF 10% 35VDCW	
A10C5	0180-0100	C:FXD ELECT 4.7 UF 10% 35VDCW	
A10C6	0180-0100	C:FXD ELECT 4.7 UF 10% 35VDCW	
A10C7	0186-0100	C:FXD ELECT 4.7 UF 10% 35VDCW	
A10C8	0180-0100	C:FXD ELECT 4.7 UF 10% 35VDCW	
A10C9	0180-0100	C:FXD ELECT 4.7 UF 10% 35VDCW	
A10C10	0180-0100	C:FXD ELECT 4.7 UF 10% 35VDCW	
A10C11	0180-0100	C:FXD ELECT 4.7 UF 10% 35VDCW	
A10C12	0180-0100	C:FXD ELECT 4.7 UF 10% 35VDCW	
A10C13	0140-0179	C:FXD MICA 1000 PF 2%	
A10C14	0140-0155	C:FXD MICA 1325 PF 1% 500VDCW	
A10C15	0160-2261	C:FXD CER 15 PF 5% 500VDCW	
A10C16	0160-2211	C:FXD MICA 510 PF 5% 300VDCW	
A10C17	0160-2211	C:FXD MICA 510 PF 5% 300VDCW	
A10CR1	08405-8004	DIODES:SILICON MATCHED PAIR	
A10CR2		PART OF A10CR1	
A10CR3	08405-8004	DIODES:SILICON MATCHED PAIR	
A10CR4		PART OF A10CR3	
A10CR5	08405-8004	DIODES:SILICON MATCHED PAIR	
A10CR6		PART OF A10CR5	
A10L1	9100-1628	COIL:MOLDED CHOKE 43.0 UH 5%	
A10MP1	5020-2045	CARD EXTRACTOR	
A10Q1	1854-0371	TRANSISTOR:SILICON NPN	
A10Q2	1854-0371	TRANSISTOR:SILICON NPN	
A10Q3	1854-0371	TRANSISTOR:SILICON NPN	
A10Q4	1854-0371	TRANSISTOR:SILICON NPN	
A10R1	0757-0428	R:FXD MET FLM 1.62K OHM 1% 1/8W	
A10R2	0757-0288	R:FXD MET FLM 9.09K OHM 1% 1/8W	
A10R3	0757-0438	R:FXD MET FLM 5.11K OHM 1% 1/8W	
A10R4	0757-0280	R:FXD MET FLM 1K OHM 1% 1/8W	
A10R5	0757-0406	R:FXD MET FLM 182 OHM 1% 1/8W	
A10R6	0698-3444	R:FXD MET FLM 316 OHM 1% 1/8W	
A10R7	0757-0280	R:FXD MET FLM 1K OHM 1% 1/8W	
A10R8	0698-3441	R:FXD MET FLM 215 OHM 1% 1/8W	
A10R9	0698-3153	R:FXD MET FLM 3.83K OHM 1% 1/8W	
A10R10	0757-0439	R:FXD MET FLM 6.81K OHM 1% 1/8W	
A10R11	0698-0082	R:FXD MET FLM 464 OHM 1% 1/8W	

See introduction to this section for ordering information

Table 6-1. Reference Designation Index (Cont'd)

Reference Designation	Part No.	Description #	Note
A10R12	0698-3155	R:FXD MET FLM 4.64K OHM 1% 1/8W	
A10R13	0698-3406	R:FXD MET FLM 1.33K OHM 1% 1/2W	
A10R14	0698-3136	R:FXD MET FLM 17.8K OHM 1% 1/8W	
A10R15	0698-3438	R:FXD MET FLM 147 OHM 1% 1/8W	
A10R16	0698-3155	R:FXD MET FLM 4.64K OHM 1% 1/8W	
A10R17	0698-0082	R:FXD MET FLM 464 OHM 1% 1/8W	
A10R18	0698-3136	R:FXD MET FLM 17.8K OHM 1% 1/8W	
A10R19	0698-3406	R:FXD MET FLM 1.33K OHM 1% 1/2W	
A10R20	0698-3442	R:FXD MET FLM 237 OHM 1% 1/8W	
A10R21	0757-0422	R:FXD MET FLM 909 OHM 1% 1/8W	
A10R22	0698-3440	R:FXD MET FLM 196 OHM 1% 1/8W	
A10R23	0757-0394	R:FXD MET FLM 51.1 OHM 1% 1/8W	
A10R24	0757-0394	R:FXD MET FLM 51.1 OHM 1% 1/8W	
A11	08405-6057	BOARD ASSY:IF SAMPLER	
A11C1	0160-2278	C:FXD MICA 34000 PF 2%	
A11C2	0160-2276	C:FXD MICA 2780 PF 2% 300VDCW	
A11C3	0180-0116	C:FXD ELECT 6.8 UF 10% 35VDCW	
A11C4	0140-0156	C:FXD MICA 1500 PF 2%	
A11C5	0160-2277	C:FXD MICA 15000 PF 2%	
A11C6	0160-2277	C:FXD MICA 15000 PF 2%	
A11C7	0160-0174	C:FXD CER 0.47 UF +80-20% 25VDCW	
A11C8	0140-0170	C:FXD MICA 5600 PF 5% 300VDCW	
A11C9		NOT ASSIGNED	
A11C10		NOT ASSIGNED	
A11C11	0140-0179	C:FXD MICA 1000 PF 2%	
A11C12	0160-2917	C:FXD CER 0.05 UF +80-20% 100VDCW	
A11C13	0140-0179	C:FXD MICA 1000 PF 2%	
A11C14		NOT ASSIGNED	
A11C15		NOT ASSIGNED	
A11C16	0140-0170	C:FXD MICA 5600 PF 5% 300VDCW	
A11C17	0140-0179	C:FXD MICA 1000 PF 2%	
A11C18		NOT ASSIGNED	
A11C19	0180-0116	C:FXD ELECT 6.8 UF 10% 35VDCW	
A11C20	0160-0174	C:FXD CER 0.47 UF +80-20% 25VDCW	
A11CR1	1901-0040	DIODE:SILICON 30MA 30WV	
A11CR2	1901-0040	DIODE:SILICON 30MA 30WV	
A11CR3	1901-0040	DIODE:SILICON 30MA 30WV	
A11CR4	1901-0040	DIODE:SILICON 30MA 30WV	
A11CR5	1902-0184	DIODE BREAKDOWN:SILICON 16.2V 5%	
A11CR6	1901-0040	DIODE:SILICON 30MA 30WV	
A11CR7	1901-0040	DIODE:SILICON 30MA 30WV	
A11CR8	1901-0025	DIODE:SILICON 100WV 100MA	
A11CR9	1901-0025	DIODE:SILICON 100WV 100MA	
A11CR10	1901-0040	DIODE:SILICON 30MA 30WV	
A11CR11	1901-0040	DIODE:SILICON 30MA 30WV	

See introduction to this section for ordering information

Table 6-1. Reference Designation Index (Cont'd)

Reference Designation	Part No.	Description #	Note
A11CR12	1901-0040	DIODE:SILICON 30MA 30WV	
A11CR13	1901-0040	DIODE:SILICON 30MA 30WV	
A11CR14	1901-0040	DIODE:SILICON 30MA 30WV	
A11CR15	1901-0040	DIODE:SILICON 30MA 30WV	
A11CR16	1901-0040	DIODE:SILICON 30MA 30WV	
A11CR17	1901-0040	DIODE:SILICON 30MA 30WV	
A11CR18	1902-0184	DIODE BREAKDOWN:SILICON 16.2V 5%	
A11CR19	1901-0040	DIODE:SILICON 30MA 30WV	
A11CR20	1901-0040	DIODE:SILICON 30MA 30WV	
A11CR21	1901-0040	DIODE:SILICON 30MA 30WV	
A11CR22	1901-0040	DIODE:SILICON 30MA 30WV	
A11MP1	5020-2045	CARD EXTRACTOR	
A11Q1	1854-0071	TRANSISTOR:SILICON NPN	
A11Q2	1854-0039 1205-0018	TRANSISTOR:SILICON NPN 2N3053 HEAT SINK	
A11Q3	1853-0010	TRANSISTOR:SILICON PNP	
A11Q4	1854-0005	TRANSISTOR:SILICON NPN 2N708	
A11Q5	1854-0005	TRANSISTOR:SILICON NPN 2N708	
A11Q6	1853-0010	TRANSISTOR:SILICON PNP	
A11Q7	1854-0039	TRANSISTOR:SILICON NPN 2N3053	
A11R1	0698-3136	R:FXD MET FLM 17.8K OHM 1% 1/8W	
A11R2	0698-3151	R:FXD MET FLM 2.87K OHM 1% 1/8W	
A11R3	0757-0428	R:FXD MET FLM 1.62K OHM 1% 1/8W	
A11R4	0698-3153	R:FXD MET FLM 3.83K OHM 1% 1/8W	
A11R5	0698-0082	R:FXD MET FLM 464 OHM 1% 1/8W	
A11R6	0698-3431	R:FXD MET FLM 23.7 OHM 1% 1/8W	
A11R7	0757-0280	R:FXD MET FLM 1K OHM 1% 1/8W	
A11R8	0757-0815	R:FXD MET FLM 562 OHM 1% 1/2W	
A11R9	0757-0815	R:FXD MET FLM 562 OHM 1% 1/2W	
A11R10	0757-0401	R:FXD MET FLM 100 OHM 1% 1/8W	
A11R11	0757-0401	R:FXD MET FLM 100 OHM 1% 1/8W	
A11R12	0757-0465	R:FXD MET FLM 100K OHM 1% 1/8W	
A11R13	0757-0465	R:FXD MET FLM 100K OHM 1% 1/8W	
A11R14		NOT ASSIGNED	
A11R15	0698-0084	R:FXD MET FLM 2.15K OHM 1% 1/8W	
A11R16		NOT ASSIGNED	
A11R17		NOT ASSIGNED	
A11R18	0698-0084	R:FXD MET FLM 2.15K OHM 1% 1/8W	
A11R19	0698-3450	R:FXD MET FLM 42.2K OHM 1% 1/8W	
A11R20	0698-3162	R:FXD MET FLM 46.4K OHM 1% 1/8W	
A11R21	0698-3154	R:FXD MET FLM 4.22K OHM 1% 1/8W	
A11R22	0698-3162	R:FXD MET FLM 46.4K OHM 1% 1/8W	
A11R23	2100-1761	R:VAR WW 10K OHM 5% 1W	
A11R24	2100-1760	R:VAR WW 5K OHM 5% 1W	
A11R25	0698-3450	R:FXD MET FLM 42.2K OHM 1% 1/8W	
A11R26	0698-0084	R:FXD MET FLM 2.15K OHM 1% 1/8W	
A11R27		NOT ASSIGNED	

See introduction to this section for ordering information

Table 6-1. Reference Designation Index (Cont'd)

Reference Designation	Part No.	Description #	Note
A11R28	0698-0084	R:FXD MET FLM 2.15K OHM 1% 1/8W	
A11R29		NOT ASSIGNED	
A11R30		NOT ASSIGNED	
A11R31	0698-3431	R:FXD MET FLM 23.7 OHM 1% 1/8W	
A11T1	08405-8002	TRANSFORMER:IF	
A11T2	08405-8002	TRANSFORMER:IF	
A12	08405-6012	BOARD ASSY:SEARCH	
A12C1	0160-0161	C:FXD MY 0.01 UF 10% 200VDCW	
A12C2	0140-0193	C:FXD MICA 82 PF 5%	
A12C3	0160-2055	C:FXD CER 0.01 UF +80-20% 100VDCW	
A12C4	0140-0197	C:FXD MICA 180 PF 5% 300 VDCW	
A12C5	0180-0195	C:FXD ELECT 0.33 UF 20% 35VDCW	
A12C6	0160-0163	C:FXD MY 0.033 UF 10% 200VDCW	
A12C7	0140-0176	C:FXD MICA 100 PF 2%	
A12C8	0150-0070	C:FXD CER 0.02 UF 20% 500VDCW	
A12C9	0160-0127	C:FXD CER 1.0 UF 20% 25VDCW	
A12C10	0160-2917	C:FXD CER 0.05 UF +80-20% 100VDCW	
A12C11	0180-0116	C:FXD ELECT 6.8 UF 10% 35VDCW	
A12C12	0180-0116	C:FXD ELECT 6.8 UF 10% 35VDCW	
A12C13	0160-2261	C:FXD CER 15 PF 5% 500VDCW	
A12C14	0160-2261	C:FXD CER 15 PF 5% 500VDCW	
A12C15	0160-2261	C:FXD CER 15 PF 5% 500VDCW	
A12C16	0180-0100	C:FXD ELECT 4.7 UF 10% 35VDCW	
A12CR1	1901-0025	DIODE:SILICON 100WV 100MA	
A12CR2	1901-0040	DIODE:SILICON 30MA 30WV	
A12CR3	1901-0040	DIODE:SILICON 30MA 30WV	
A12MP1	5020-2045	CARD EXTRACTOR	
A12Q1	1854-0071	TRANSISTOR:SILICON NPN	
A12Q2	1854-0071	TRANSISTOR:SILICON NPN	
A12Q3	1854-0071	TRANSISTOR:SILICON NPN	
A12Q4	1853-0009	TRANSISTOR:SILICON PNP	
A12Q5	1854-0071	TRANSISTOR:SILICON NPN	
A12Q6	1853-0010	TRANSISTOR:SILICON PNP	
A12Q7	1853-0020	TRANSISTOR:SILICON PNP	
A12Q8	1854-0071	TRANSISTOR:SILICON NPN	
A12Q9	1854-0071	TRANSISTOR:SILICON NPN	
A12Q10	1853-0020	TRANSISTOR:SILICON PNP	
A12R1	0698-3459	R:FXD MET FLM 383K OHM 1% 1/8W	
A12R2	0698-3162	R:FXD MET FLM 46.4K OHM 1% 1/8W	
A12R3	0757-0442	R:FXD MET FLM 10.0K OHM 1% 1/8W	
A12R4	0698-3150	R:FXD MET FLM 2.37K OHM 1% 1/8W	
A12R5	0698-3455	R:FXD MET FLM 261K OHM 1% 1/8W	

See introduction to this section for ordering information

Table 6-1. Reference Designation Index (Cont'd)

Reference Designation	Part No.	Description #	Note
A12R6	0757-0438	R:FXD MET FLM 5.11K OHM 1% 1/8W	
A12R7	0698-0083	R:FXD MET FLM 1.96K OHM 1% 1/8W	
A12R8	0757-0290	R:FXD MET FLM 6.19K OHM 1% 1/8W	
A12R9	0698-3440	R:FXD MET FLM 196 OHM 1% 1/8W	
A12R10	0698-0083	R:FXD MET FLM 1.96K OHM 1% 1/8W	
A12R11	0757-0442	R:FXD MET FLM 10.0K OHM 1% 1/8W	
A12R12	0698-0084	R:FXD MET FLM 2.15K OHM 1% 1/8W	
A12R13	0757-0290	R:FXD MET FLM 6.19K OHM 1% 1/8W	
A12R14	0698-3449	R:FXD MET FLM 28.7K OHM 1% 1/8W	
A12R15	0698-3449	R:FXD MET FLM 28.7K OHM 1% 1/8W	
A12R16	0757-0461	R:FXD MET FLM 68.1K OHM 1% 1/8W	
A12R17	0698-3453	R:FXD MET FLM 196K OHM 1% 1/8W	
A12R18	0698-3153	R:FXD MET FLM 3.83K OHM 1% 1/8W	
A12R19	0757-0200	R:FXD MET FLM 5.62K OHM 1% 1/8W	
A12R20	0757-0465	R:FXD MET FLM 100K OHM 1% 1/8W	
A12R21	0757-0441	R:FXD MET FLM 8.25K OHM 1% 1/8W	
A12R22	0757-1094	R:FXD MET FLM 1.47K OHM 1% 1/8W	
A12R23	0698-3449	R:FXD MET FLM 28.7K OHM 1% 1/8W	
A12R24	0757-0460	R:FXD MET FLM 61.9K OHM 1% 1/8W	
A12R25	2100-0942	R:VAR FLM 50K OHM 20% 3/4W	
A12R26	0698-3152	R:FXD MET FLM 3.48K OHM 1% 1/8W	
A12R27	0698-4315	R:FXD COMP 430 OHM 5% 1/2W	
A12R28	0698-3158	R:FXD MET FLM 23.7K OHM 1% 1/8W	
A12R29	0757-0346	R:FXD MET FLM 10 OHM 1% 1/8W	
A12R30	0686-1055	R:FXD COMP 1 MEGOHM 5% 1/2W	
A12R31	0698-3449	R:FXD MET FLM 28.7K OHM 1% 1/8W	
A12R32	0698-3155	R:FXD MET FLM 4.64K OHM 1% 1/8W	
A12R33	0757-0462	R:FXD MET FLM 75.0K OHM 1% 1/8W	
A12R34	0757-0447	R:FXD MET FLM 16.2K OHM 1% 1/8W	
A12R35	0698-0083	R:FXD MET FLM 1.96K OHM 1% 1/8W	
A12R36	0698-3150	R:FXD MET FLM 2.37K OHM 1% 1/8W	
A12R37	0757-0394	R:FXD MET FLM 51.1 OHM 1% 1/8W	
A12R38	0757-0394	R:FXD MET FLM 51.1 OHM 1% 1/8W	
A12R39	0698-3454	R:FXD MET FLM 215K OHM 1% 1/8W	
A12R40	0698-3440	R:FXD MET FLM 196 OHM 1% 1/8W	
A12R41	0698-3440	R:FXD MET FLM 196 OHM 1% 1/8W	
A12R42	0698-3440	R:FXD MET FLM 196 OHM 1% 1/8W	
A12R43	0698-3440	R:FXD MET FLM 196 OHM 1% 1/8W	
A12R44	0757-0280	R:FXD MET FLM 1K OHM 1% 1/8W	
A13	08405-6013	BOARD ASSY:EQUALIZER	
A13C1	0140-0157	C:FXD MICA 1857 PF 1%	
A13C2	0180-1746	C:FXD ELECT 15 UF 10% 20VDCW	
A13C3	0160-0168	C:FXD MY 0.1 UF 10% 200VDCW	
A13C4	0160-0168	C:FXD MY 0.1 UF 10% 200VDCW	
A13C5	0140-0182	C:FXD MICA 5000 PF 2%	
A13C6	0160-2279	C:FXD MICA 880 PF 2% 300VDCW	

See introduction to this section for ordering information

Table 6-1. Reference Designation Index (Cont'd)

Reference Designation	Part No.	Description #	Note
A13C7	0160-2261	C:FXD CER 15 PF 5% 500VDCW	
A13C8	0160-2261	C:FXD CER 15 PF 5% 500VDCW	
A13C9	0160-2261	C:FXD CER 15 PF 5% 500VDCW	
A13L1	9100-1653	COIL:MOLED CHOKE 910.0 OHM 5%	
A13Q1	1854-0071	TRANSISTOR:SILICON NPN	
A13Q2	1854-0071	TRANSISTOR:SILICON NPN	
A13Q3	1854-0071	TRANSISTOR:SILICON NPN	
A13R1	0698-3460	R:FXD MET FLM 422K OHM 1% 1/8W	
A13R2	0757-0441	R:FXD MET FLM 8.25K OHM 1% 1/8W	
A13R3	0698-0083	R:FXD MET FLM 1.96K OHM 1% 1/8W	
A13R4	0698-3136	R:FXD MET FLM 17.8K OHM 1% 1/8W	
A13R5	0698-3158	R:FXD MET FLM 23.7K OHM 1% 1/8W	
A13R6	0757-0405	R:FXD MET FLM 162 OHM 1% 1/8W	
A13R7	0757-0402	R:FXD MET FLM 110 OHM 1% 1/8W	
A13R8	0698-3157	R:FXD MET FLM 19.6K OHM 1% 1/8W	
A13R9	0698-3132	R:FXD MET FLM 261 OHM 1% 1/8W	
A13R10	0698-3161	R:FXD MET FLM 38.3K OHM 1% 1/8W	
A13R11	0757-0424	R:FXD MET FLM 1.10K OHM 1% 1/8W	
A13R12	0757-0447	R:FXD MET FLM 16.2K OHM 1% 1/8W	
A13R13	0757-0420	R:FXD MET FLM 750 OHM 1% 1/8W	
A13R14	0698-0084	R:FXD MET FLM 2.15K OHM 1% 1/8W	
A13R15	0698-3136	R:FXD MET FLM 17.8K OHM 1% 1/8W	
A13R16	0757-0439	R:FXD MET FLM 6.81K OHM 1% 1/8W	
A13R17	0757-0403	R:FXD MET FLM 121 OHM 1% 1/8W	
A13R18	0698-0082	R:FXD MET FLM 464 OHM 1% 1/8W	
A13R19	0698-0082	R:FXD MET FLM 464 OHM 1% 1/8W	
A13R20	0698-3440	R:FXD MET FLM 196 OHM 1% 1/8W	
A13R21	0698-3440	R:FXD MET FLM 196 OHM 1% 1/8W	
A13R22	0698-3440	R:FXD MET FLM 196 OHM 1% 1/8W	
A14	08405-6014	BOARD ASSY:VTO	
A14C1	0160-2055	C:FXD CER 0.01 UF +80-20% 100VDCW	
A14C2	0140-0176	C:FXD MICA 100 PF 2%	
A14C3	0180-0061	C:FXD ELECT 100UF +100%-10% 15VDCW	
A14C4	0160-2055	C:FXD CER 0.01 UF +80-20% 100VDCW	
A14C5	0140-0204	C:FXD MICA 47PF 5% NPO 500VDCW	
A14C6	0140-0176	C:FXD MICA 100 PF 2%	
A14C7	0180-0116	C:FXD ELECT 6.8 UF 10% 35VDCW	
A14C8	0140-0204	C:FXD MICA 47PF 5% NPO 500VDCW	
A14C9	0140-0176	C:FXD MICA 100 PF 2%	
A14C10	0150-0051	C:FXD CER 100 PF 600VDCW	
A14C11	0180-0138	C:FXD ELECT 100UF -10+100% 40VDCW	
A14C12	0180-0100	C:FXD ELECT 4.7 UF 10% 35VDCW	
A14C13	0150-0069	C:FXD CER 1000 PF +100-20% 500VDCW	
A14C14	0180-0291	C:FXD ELECT 1.0 UF 10% 35VDCW	
A14C15	0180-0116	C:FXD ELECT 6.8 UF 10% 35VDCW	

See introduction to this section for ordering information

Table 6-1. Reference Designation Index (Cont'd)

Reference Designation	Part No.	Description #	Note
A14C16	0160-2055	C:FXD CER 0.01 UF +80-20% 100VDCW	
A14C17	0160-2261	C:FXD CER 15 PF 5% 500VDCW	
A14CR1	1901-0040	DIODE:SILICON 30MA 30WV	
A14CR2	1901-0040	DIODE:SILICON 30MA 30WV	
A14CR3	1901-0040	DIODE:SILICON 30MA 30WV	
A14CR4	1901-0040	DIODE:SILICON 30MA 30WV	
A14CR5	1901-0040	DIODE:SILICON 30MA 30WV	
A14CR6	1901-0040	DIODE:SILICON 30MA 30WV	
A14CR7	1901-0040	DIODE:SILICON 30MA 30WV	
A14CR8	1901-0040	DIODE:SILICON 30MA 30WV	
A14L1	9140-0138	COIL/CHOKE 180 UH 5%	
A14L2	9140-0096	COIL:FXD RF 1 UH	
A14L3	9140-0138	COIL/CHOKE 180 UH 5%	
A14C1	1854-0071	TRANSISTOR:SILICON NPN	
A14C2	1854-0071	TRANSISTOR:SILICON NPN	
A14C3	1854-0071	TRANSISTOR:SILICON NPN	
A14C4	1854-0003	TRANSISTOR:NPN SILICON	
A14C5	1853-0009	TRANSISTOR:SILICON PNP	
A14C6	1853-0009	TRANSISTOR:SILICON PNP	
A14Q7	08405-8003	TRANSISTOR:NPN SILICON SELECTED	
A14Q8	08405-8003	TRANSISTOR:NPN SILICON SELECTED	
A14R1	0698-0085	R:FXD MET FLM 2.61K OHM 1% 1/8W	
A14R2	0757-0280	R:FXD MET FLM 1K OHM 1% 1/8W	
A14R3	0698-3243	R:FXD MET FLM 178K OHM 1% 1/8W	
A14R4	0757-0443	R:FXD MET FLM 11.0K OHM 1% 1/8W	
A14R5	0757-0199	R:FXD MET FLM 21.5K OHM 1% 1/8W	
A14R6	0757-0317	R:FXD MET FLM 1.33K OHM 1% 1/8W	
A14R7	0757-0465	R:FXD MET FLM 100K OHM 1% 1/8W	
A14R8	0757-0442	R:FXD MET FLM 10.0K OHM 1% 1/8W	
A14R9	0698-0083	R:FXD MET FLM 1.96K OHM 1% 1/8W	
A14R10	0698-0083	R:FXD MET FLM 1.96K OHM 1% 1/8W	
A14R11	0757-0346	R:FXD MET FLM 10 OHM 1% 1/8W	
A14R12	0757-0416	R:FXD MET FLM 511 OHM 1% 1/8W	
A14R13	0698-0083	R:FXD MET FLM 1.96K OHM 1% 1/8W	
A14R14	0698-0083	R:FXD MET FLM 1.96K OHM 1% 1/8W	
A14R15	0698-4037	R:FXD MET FLM 46.4 OHM 1% 1/8W	
A14R16	0757-0442	R:FXD MET FLM 10.0K OHM 1% 1/8W	
A14R17	0757-0442	R:FXD MET FLM 10.0K OHM 1% 1/8W	
A14R18	0698-4037	R:FXD MET FLM 46.4 OHM 1% 1/8W	
A14R19	0698-3153	R:FXD MET FLM 3.83K OHM 1% 1/8W	
A14R20	0698-3155	R:FXD MET FLM 4.64K OHM 1% 1/8W	

See introduction to this section for ordering information

Table 6-1. Reference Designation Index (Cont'd)

Reference Designation	Part No.	Description #	Note
A14R21	0698-3155	R:FXD MET FLM 4.64K OHM 1% 1/8W	
A14R22	0698-3153	R:FXD MET FLM 3.83K OHM 1% 1/8W	
A14R23	0757-0706	R:FXD MET FLM 51.1 OHM 1% 1/4W	
A14R24	0698-3440	R:FXD MET FLM 196 OHM 1% 1/8W	
A15	08405-6015	BOARD ASSY:PULSE GENERATOR	
A15C1	0160-0342	C:FXD MICA 800 PF 1% 300VDCW	
A15C2	0150-0121	C:FXD CER 0.1 UF +80-20% 50VDCW	
A15C3	0150-0121	C:FXD CER 0.1 UF +80-20% 50VDCW	
A15C4	0140-0206	C:FXD MICA 270 PF 5%	
A15C5	0180-0100	C:FXD ELECT 4.7 UF 10% 35VDCW	
A15C6	0150-0050	C:FXD CER 1000 PF 600VDCW	
A15C7	0140-0176	C:FXD MICA 100 PF 2%	
A15CR1	1901-0441	DIODE:STEP RECOVERY SILICON 90-160NS	
A15CR2	1901-0047	DIODE JUNCTION:SILICON 20PIV	
A15CR3	1902-0126	DIODE BREAKDOWN:2.61V 5%	
A15CR4	1901-0040	DIODE:SILICON 30MA 30WV	
A15L1	9140-0138	COIL/CHOKE 180 UH 5%	
A15L2	9140-0096	COIL:FXD RF 1 UH	
A15L3	9140-0096	COIL:FXD RF 1 UH	
A15L4	9140-0181	COIL:FXD RF 22UH 5%	
A15L5	9140-0096	COIL:FXD RF 1 UH	
A15G1	1854-0035	TRANSISTOR:NPN SILICON	
A15Q2	1853-0009	TRANSISTOR:SILICON PNP	
	1205-0012	HEAT DISSIPATOR:SEMICONDUCTOR	
A15R1	0757-0394	R:FXD MET FLM 51.1 OHM 1% 1/8W	
A15R2	0757-0394	R:FXD MET FLM 51.1 OHM 1% 1/8W	
A15R3	2100-1756	R:VAR WW 200 OHM 5% 1W	
A15R4	0757-0405	R:FXD MET FLM 162 OHM 1% 1/8W	
A15R5	0698-3403	R:FXD MET FLM 348 OHM 1% 1/2W	
A15R6	0757-0198	R:FXD MET FLM 100 OHM 1% 1/2W	
A15R7	0698-3442	R:FXD MET FLM 237 OHM 1% 1/8W	
A15R8	0698-3405	R:FXD MET FLM 422 OHM 1% 1/2W	
A15R9	0766-0024	R:FXD MET FLM 260 OHM 2% 3W	
A15T1	9100-1698	TRANSFORMER:PULSE	
A16	08405-6016	BOARD ASSY:POWER SUPPLY	
A16C1	0180-0050	C:FXD ELECT 40 UF +75-10% 50VDCW	
A16C2	0180-0230	C:FXD ELECT 1.0 UF 20% 50VDCW	
A16C3	0180-0138	C:FXD ELECT 100UF -10+100% 40VDCW	
A16C4	0180-0050	C:FXD ELECT 40 UF +75-10% 50VDCW	
A16C5	0180-0230	C:FXD ELECT 1.0 UF 20% 50VDCW	

See introduction to this section for ordering information

Table 6-1. Reference Designation Index (Cont'd)

Reference Designation	Part No.	Description #	Note
A16C6	0180-0138	C:FXD ELECT 100UF -10+100% 40VDCW	
A16CR1	1901-0026	DIODE:SILICON 0.75A 200 PIV	
A16CR2	1901-0026	DIODE:SILICON 0.75A 200 PIV	
A16CR3	1902-0062	DIODE BREAKDOWN:3.75V	
A16CR4	1901-0033	DIODE:SILICON 100MA 180WV	
A16CR5	1901-0033	DIODE:SILICON 100MA 180WV	
A16CR6	1901-0033	DIODE:SILICON 100MA 180WV	
A16CR7	1902-0057	DIODE BREAKDOWN:6.49V	
A16CR8	1901-0026	DIODE:SILICON 0.75A 200 PIV	
A16CR9	1901-0026	DIODE:SILICON 0.75A 200 PIV	
A16CR10	1902-0062	DIODE BREAKDOWN:3.75V	
A16CR11	1901-0033	DIODE:SILICON 100MA 180WV	
A16CR12	1901-0033	DIODE:SILICON 100MA 180WV	
A16CR13	1901-0033	DIODE:SILICON 100MA 180WV	
A16CR14	1902-0057	DIODE BREAKDOWN:6.49V	
A16MF1	5020-2045	CARD EXTRACTOR	
A16Q1	1854-0020	TRANSISTOR:NPN SILICON	
A16Q2	1853-0009	TRANSISTOR:SILICON PNP	
A16Q3	1854-0071	TRANSISTOR:SILICON NPN	
A16Q4	1854-0020	TRANSISTOR:NPN SILICON	
A16Q5	1853-0009	TRANSISTOR:SILICON PNP	
A16Q6	1854-0071	TRANSISTOR:SILICON NPN	
A16R1	0811-0040	R:FXD WW 1 OHM 1% 5W	
A16R2	0757-0198	R:FXD MET FLM 100 OHM 1% 1/2W	
A16R3	0757-0317	R:FXD MET FLM 1.33K OHM 1% 1/8W	
A16R4	0698-3155	R:FXD MET FLM 4.64K OHM 1% 1/8W	
A16R5	0757-0424	R:FXD MET FLM 1.10K OHM 1% 1/8W	
A16R6	0811-0040	R:FXD WW 1 OHM 1% 5W	
A16R7	0757-0424	R:FXD MET FLM 1.10K OHM 1% 1/8W	
A16R8	0757-0077	R:FXD FLM 1.2K OHM 2% 1/4W	
A16R9	0757-0398	R:FXD MET FLM 75 OHM 1% 1/8W	
A16R10	0698-0084	R:FXD MET FLM 2.15K OHM 1% 1/8W	
A16R11	2100-0328	R:VAR WW 500 OHM 10% LIN 1W	
A16R12	0757-0424	R:FXD MET FLM 1.10K OHM 1% 1/8W	
A16R13	0811-0040	R:FXD WW 1 OHM 1% 5W	
A16R14	0757-0198	R:FXD MET FLM 100 OHM 1% 1/2W	
A16R15	0757-0317	R:FXD MET FLM 1.33K OHM 1% 1/8W	
A16R16	0698-3155	R:FXD MET FLM 4.64K OHM 1% 1/8W	
A16R17	0757-0424	R:FXD MET FLM 1.10K OHM 1% 1/8W	
A16R18	0757-0424	R:FXD MET FLM 1.10K OHM 1% 1/8W	
A16R19	0811-0040	R:FXD WW 1 OHM 1% 5W	
A16R20	0757-0077	R:FXD FLM 1.2K OHM 2% 1/4W	
A16R21	0757-0398	R:FXD MET FLM 75 OHM 1% 1/8W	
A16R22	0698-0084	R:FXD MET FLM 2.15K OHM 1% 1/8W	
A16R23	2100-0328	R:VAR WW 500 OHM 10% LIN 1W	
A16R24	0757-0424	R:FXD MET FLM 1.10K OHM 1% 1/8W	
A17	08405-6017	DELAY LINE ASSY	

See introduction to this section for ordering information

Table 6-1. Reference Designation Index (Cont'd)

Reference Designation	Part No.	Description #	Note
A18	08405-6003	BOARD ASSY:ISOLATION AMP.	
A18C1	0180-0100	C:FXD ELECT 4.7 UF 10% 35VDCW	
A18C2	0150-0121	C:FXD CER 0.1 UF +80-20% 50VDCW	
A18C3	0180-0137	C:FXD ELECT 100 UF 20% 10VDCW	
A18C4	0160-2120	C:FXD MICA 0.01UF 1%	
A18C5	0180-0100	C:FXD ELECT 4.7 UF 10% 35VDCW	
A18C6	0180-0100	C:FXD ELECT 4.7 UF 10% 35VDCW	
A18C7	0180-2071	C:FXD ELECT 0.022 UF 10% 35VDCW	
A18C8	0180-0100	C:FXD ELECT 4.7 UF 10% 35VDCW	
A18C9	0180-0100	C:FXD ELECT 4.7 UF 10% 35VDCW	
A18C10	0180-0100	C:FXD ELECT 4.7 UF 10% 35VDCW	
A18C11	0180-0100	C:FXD ELECT 4.7 UF 10% 35VDCW	
A18C12	0180-0100	C:FXD ELECT 4.7 UF 10% 35VDCW	
A18C13	0180-0100	C:FXD ELECT 4.7 UF 10% 35VDCW	
A18C14	0180-0100	C:FXD ELECT 4.7 UF 10% 35VDCW	
A18C15	0180-0100	C:FXD ELECT 4.7 UF 10% 35VDCW	
A18C16	0160-2143	C:FXD CER 2000 PF +80-20% 1000VDCW	
A18C17	0160-2261	C:FXD CER 15 PF 5% 500VDCW	
A18CR1	08405-8004	DIODES:SILICON MATCHED PAIR	
A18CR2		PART OF A18CR1	
A18L1	9100-1719	COIL:VAR	
A18L2	9140-0114	COIL:FXD RF 10 UH	
A18MP1	5020-2045	CARD EXTRACTOR	
A18Q1	1854-0071	TRANSISTOR:SILICON NPN	
A18Q2	1854-0071	TRANSISTOR:SILICON NPN	
A18Q3	1854-0071	TRANSISTOR:SILICON NPN	
A18Q4	1854-0071	TRANSISTOR:SILICON NPN	
A18Q5	1854-0071	TRANSISTOR:SILICON NPN	
A18Q6	1854-0071	TRANSISTOR:SILICON NPN	
A18R1	0757-0459	R:FXD MET FLM 56.2K OHM 1% 1/8W	
A18R2	0698-3157	R:FXD MET FLM 19.6K OHM 1% 1/8W	
A18R3	0698-3157	R:FXD MET FLM 19.6K OHM 1% 1/8W	
A18R4	0757-0442	R:FXD MET FLM 10.0K OHM 1% 1/8W	
A18R5	0698-3160	R:FXD MET FLM 31.6K OHM 1% 1/8W	
A18R6	0757-0280	R:FXD MET FLM 1K OHM 1% 1/8W	
A18R7	0757-0444	R:FXD MET FLM 12.1K OHM 1% 1/8W	
A18R8	0698-0083	R:FXD MET FLM 1.96K OHM 1% 1/8W	
A18R9		NOT ASSIGNED	
A18R10	0757-0442	R:FXD MET FLM 10.0K OHM 1% 1/8W	
A18R11	2100-1760	R:VAR WW 5K OHM 5% 1W	
A18R12	0757-0447	R:FXD MET FLM 16.2K OHM 1% 1/8W	
A18R13	0757-0278	R:FXD MET FLM 1.78K OHM 1% 1/8W	
A18R14	0757-0428	R:FXD MET FLM 1.62K OHM 1% 1/8W	
A18R15	0757-0428	R:FXD MET FLM 1.62K OHM 1% 1/8W	

See introduction to this section for ordering information

Table 6-1. Reference Designation Index (Cont'd)

Reference Designation	Part No.	Description #	Note
A18R16	0757-0288	R:FXD MET FLM 9.09K OHM 1% 1/8W	
A18R17	0757-0438	R:FXD MET FLM 5.11K OHM 1% 1/8W	
A18R18	0757-0280	R:FXD MET FLM 1K OHM 1% 1/8W	
A18R19	0757-0394	R:FXD MET FLM 51.1 OHM 1% 1/8W	
A18R20	0698-3444	R:FXD MET FLM 316 OHM 1% 1/8W	
A18R21	0757-0280	R:FXD MET FLM 1K OHM 1% 1/8W	
A18R22	0698-3441	R:FXD MET FLM 215 OHM 1% 1/8W	
A18R23	0698-3153	R:FXD MET FLM 3.83K OHM 1% 1/8W	
A18R24	0757-0439	R:FXD MET FLM 6.81K OHM 1% 1/8W	
A18R25	0698-0082	R:FXD MET FLM 464 OHM 1% 1/8W	
A18R26	0698-3155	R:FXD MET FLM 4.64K OHM 1% 1/8W	
A18R27	0698-3136	R:FXD MET FLM 17.8K OHM 1% 1/8W	
A18R28	0698-3406	R:FXD MET FLM 1.33K OHM 1% 1/2W	
A18R29	0698-3438	R:FXD MET FLM 147 OHM 1% 1/8W	
A18R30	0698-0084	R:FXD MET FLM 2.15K OHM 1% 1/8W	
A19	08405-6035	CABLE ASSY:OUTPUT DELAY LINE	
A19CR1		NSR PART OF A19	
A20	08405-6034	CABLE ASSY:PULSE GENERATOR	
A20CR1		NSR PART OF A20	
A21	08405-6052	SWITCH ASSY:PHASE METER OFFSET	
A21R1	0698-4084	R:FXD MET FLM 19.2 OHM 1% 1/8W	
A21R2	0698-4085	R:FXD MET FLM 20.8 OHM 1% 1/8W	
A21R3	0698-4086	R:FXD MET FLM 22.6 OHM 1% 1/8W	
A21R4	0698-4087	R:FXD MET FLM 24.6 OHM 1% 1/8W	
A21R5	0698-4088	R:FXD MET FLM 27 OHM 1% 1/8W	
A21R6	0698-4089	R:FXD MET FLM 29.7 OHM 1% 1/8W	
A21R7	0698-4090	R:FXD MET FLM 32.8 OHM 1% 1/8W	
A21R8	0757-0390	R:FXD MET FLM 36.5 OHM 1% 1/8W	
A21R9	0698-4091	R:FXD MET FLM 40.8 OHM 1% 1/8W	
A21R10	0698-4092	R:FXD MET FLM 45.9 OHM 1% 1/8W	
A21R11	0698-4093	R:FXD MET FLM 52 OHM 1% 1/8W	
A21R12	0698-4094	R:FXD MET FLM 59.5 OHM 1% 1/8W	
A21R13	0698-4095	R:FXD MET FLM 68.6 OHM 1% 1/8W	
A21R14	0698-4096	R:FXD MET FLM 80.2 OHM 1% 1/8W	
A21R15	0698-4097	R:FXD MET FLM 94.8 OHM 1% 1/8W	
A21R16	0757-0275	R:FXD MET FLM 113 OHM 1% 1/8W	
A21R17	0698-4099	R:FXD MET FLM 139 OHM 1% 1/8W	
A21S1	3100-1834	SWITCH:ROTARY	
A22	08405-6051	SWITCH ASSY:AMPLITUDE RANGE	
A22C1	0140-0210	C:FXD MICA 270 PF 5%	
A22MP1	08405-0013	COVER:SWITCH	

See introduction to this section for ordering information

Table 6-1. Reference Designation Index (Cont'd)

Reference Designation	Part No.	Description #	Note
A22MP2	08405-0014	PLATE:SWITCH COVER	
A22MP3	08405-0014	PLATE:SWITCH COVER	
A22R1	0698-0084	R:FXD MET FLM 2.15K OHM 1% 1/8W	
A22R2	0698-5851	R:FXD MET FLM 6.81K OHM 0.5% 1/8W	
A22R3	0698-5847	R:FXD MET FLM 2150 OHM 0.5% 1/8W	
A22R4	0698-4100	R:FXD MET FLM 1.26K OHM 1% 1/8W	
A22R5	0698-5850	R:FXD MET FLM 681 OHM 0.5% 1/8W	
A22R6	0698-4101	R:FXD MET FLM 1.85K OHM 1% 1/8W	
A22R7	0698-5848	R:FXD MET FLM 215 OHM 0.5% 1/8W	
A22R8	0698-4102	R:FXD MET FLM 2.06K OHM 1% 1/8W	
A22R9	0698-4349	R:FXD MET FLM 99.5 OHM 1% 1/8W	
A22R10	0698-0084	R:FXD MET FLM 2.15K OHM 1% 1/8W	
A22R11	0698-5851	R:FXD MET FLM 6.81K OHM 0.5% 1/8W	
A22R12	0698-5847	R:FXD MET FLM 2150 OHM 0.5% 1/8W	
A22R13	0698-4100	R:FXD MET FLM 1.26K OHM 1% 1/8W	
A22R14	0698-5850	R:FXD MET FLM 681 OHM 0.5% 1/8W	
A22R15	0698-4101	R:FXD MET FLM 1.85K OHM 1% 1/8W	
A22R16	0698-5848	R:FXD MET FLM 215 OHM 0.5% 1/8W	
A22R17	0698-4102	R:FXD MET FLM 2.06K OHM 1% 1/8W	
A22R18	0698-4349	R:FXD MET FLM 99.5 OHM 1% 1/8W	
A22S1	3100-1833	SWITCH:ROTARY	
A22W1	08405-6039	CABLE ASSY:SHORT AMP RANGE	
A22W2	08405-6040	CABLE ASSY:MED AMP RANGE	
A22W3	08405-6041	CABLE ASSY:LONG AMP RANGE	
A23	08405-6042	SWITCH ASSY:CHANNEL	
A23MP1	08405-0013	COVER:SWITCH	
A23MP2	08405-0014	PLATE:SWITCH COVER	
A23MP3	08405-0014	PLATE:SWITCH COVER	
A23S1	3100-1832	SWITCH:ROTARY	
A23W1	08405-6028	CABLE ASSY	
A23W2	08405-6037	CABLE ASSY	
A23W3	08405-6038	CABLE ASSY	
A24	08405-6053	SWITCH ASSY:FREQ. RANGE	
A24R1	0698-3446	R:FXD MET FLM 383 OHM 1% 1/8W	
A24R2	0757-0419	R:FXD MET FLM 681 OHM 1% 1/8W	
A24R3	0757-0424	R:FXD MET FLM 1.10K OHM 1% 1/8W	
A24R4	0757-0428	R:FXD MET FLM 1.62K OHM 1% 1/8W	
A24R5	0698-0084	R:FXD MET FLM 2.15K OHM 1% 1/8W	
A24R6	0698-3151	R:FXD MET FLM 2.87K OHM 1% 1/8W	

See introduction to this section for ordering information

Table 6-1. Reference Designation Index (Cont'd)

Reference Designation	Part No.	Description #	Note
A24R7	0698-3154	R:FXD MET FLM 4.22K OHM 1% 1/8W	
A24R8	0757-0438	R:FXD MET FLM 5.11K OHM 1% 1/8W	
A24R9	0757-0440	R:FXD MET FLM 7.50K OHM 1% 1/8W	
A24R10	0757-0442	R:FXD MET FLM 10.0K OHM 1% 1/8W	
A24R11	0757-0289	R:FXD MET FLM 13.3K OHM 1% 1/8W	
A24R12	0698-3136	R:FXD MET FLM 17.8K OHM 1% 1/8W	
A24R13	0698-3159	R:FXD MET FLM 26.1K OHM 1% 1/8W	
A24R14	0698-3161	R:FXD MET FLM 38.3K OHM 1% 1/8W	
A24R15	0757-0458	R:FXD MET FLM 51.1K OHM 1% 1/8W	
A24R16	0757-0462	R:FXD MET FLM 75.0K OHM 1% 1/8W	
A24R17	0757-0466	R:FXD MET FLM 110K OHM 1% 1/8W	
A24R18	0698-3453	R:FXD MET FLM 196K OHM 1% 1/8W	
A24R19	0698-3460	R:FXD MET FLM 422K OHM 1% 1/8W	
A24R20	0683-1055	R:FXD COMP 1 MEGOHM 5% 1/4W	
A24R21	0757-0467	R:FXD MET FLM 121K OHM 1% 1/8W	
A24R22	0757-0440	R:FXD MET FLM 7.50K OHM 1% 1/8W	
A24R23	0757-0441	R:FXD MET FLM 8.25K OHM 1% 1/8W	
A24R24	0698-3155	R:FXD MET FLM 4.64K OHM 1% 1/8W	
A24R25	0698-3154	R:FXD MET FLM 4.22K OHM 1% 1/8W	
A24R26	0757-0438	R:FXD MET FLM 5.11K OHM 1% 1/8W	
A24R27	0757-0200	R:FXD MET FLM 5.62K OHM 1% 1/8W	
A24R28	0757-0290	R:FXD MET FLM 6.19K OHM 1% 1/8W	
A24R29	0757-0200	R:FXD MET FLM 5.62K OHM 1% 1/8W	
A24R30	0757-0438	R:FXD MET FLM 5.11K OHM 1% 1/8W	
A24S1	3100-1835	SWITCH:ROTARY	
A24W1	08405-6032	CABLE ASSY:COAXIAL	
A24W2	08405-6032	CABLE ASSY:COAXIAL	
A25	08405-6024	SWITCH ASSY:PHASE RANGE	
A25MP1	5040-0218	COUPLER:SWITCH SHAFT	
A25R1	0811-1638	R:FXD WW 344.8 OHM 0.1% 1/8W	
A25R2	0811-1640	R:FXD WW 1111 OHM 0.1% 1/8W	
A25R3	0698-3279	R:FXD MET FLM 4990 OHM 1% 1/8W	
A25R4	2100-0024	R:VAR COMP 1000 OHM 10% LIN 2W	
A25S1	3100-1831	SWITCH:ROTARY	
A26	08405-6018	BOARD ASSY:EXTENDER	
		CHASSIS PARTS	
C1	0150-0119	C:FXD CER 2 X 0.01 UF 20% 250VDCW	
C2	0180-0369	C:FXD ELECT 2800 UF +75-10% 60VDCW	
C3	0180-0369	C:FXD ELECT 2800 UF +75-10% 60VDCW	
C4	0150-0019	C:FXD CER 1000 PF 20% 500VDCW	
C5	0150-0019	C:FXD CER 1000 PF 20% 500VDCW	
C6	0150-0019	C:FXD CER 1000 PF 20% 500VDCW	
C7	0150-0019	C:FXD CER 1000 PF 20% 500VDCW	
C8	0150-0019	C:FXD CER 1000 PF 20% 500VDCW	
C9	0150-0019	C:FXD CER 1000 PF 20% 500VDCW	
C10	0160-2140	C:FXD CER 470 PF +80-20% 1000VDCW	

See introduction to this section for ordering information

Table 6-1. Reference Designation Index (Cont'd)

Reference Designation	Part No.	Description #	Note
C11	0160-2140	C:FXD CER 470 PF +80-20% 1000VDCW	
C12	0160-2257	C:FXD CER 10 PF 5% 500VDCW	
DS1	2140-0244	LAMP:GLOW T-2 BULB 1.0M AMP 95VAC	
DS2	1450-0708	LIGHT:INDICATOR AMBER	
F1	2110-0001	FUSE:1A 250V	
F1	2110-0202	FUSE:0.50A 250V	
F2	2110-0202	FUSE:0.50A 250V	
F3	2110-0202	FUSE:0.50A 250V	
J1		NSR PART OF W5	
J2		NSR PART OF W6	
J3	1250-0083	CONNECTOR:8NC	
J4	1250-0083	CONNECTOR:8NC	
L1	9140-0096	COIL:FXD RF 1 UH	
L2	9140-0096	COIL:FXD RF 1 UH	
L3	9140-0096	COIL:FXD RF 1 UH	
L4	9140-0096	COIL:FXD RF 1 UH	
L5	9100-1610	COIL:MOLDED CHOKE 0.15 UH 20%	
L6	9100-1610	COIL:MOLDED CHOKE 0.15 UH 20%	
L7	9140-0114	COIL:FXD RF 10 UH	
L8	9140-0114	COIL:FXD RF 10 UH	
M1	1120-0394	METER:DEGREES	
M2	1120-0361	METER:RMS VOLTS	
M2	1120-1466	METER:RMS VOLTS LIN LOG OPT 02	
P1	1251-2357	CONNECTOR:POWER 3 PIN MALE	
Q1	1854-0063	TRANSISTOR:NPN SILICON 2N3055	
Q1	1200-0077	INSULATOR:TRANSISTOR, MICA	
Q2	1854-0063	TRANSISTOR:MPN SILICON 2N3055	
Q2	1200-0077	INSULATOR:TRANSISTOR, MICA	
R1	0698-3420	R:FXD MET FLM 34.8K OHM 1% 1/2W	
R2	0813-0017	R:FXD WW 5 OHM 10% 5W	
R3	0816-0010	R:FXD WW 12 OHM 10% 10W	
R4	0757-0351	R:FXD MET FLM 402 OHM 1% 1/4W	
S1	3101-1248	SWITCH:PUSHBUTTON SPDT	
S2	3101-1234	SWITCH:SLIDE DPDT 0.5A 125V AC/DC	
S3	3101-0901	SWITCH:PUSHBUTTON 3PDT	
T1	9100-1706	TRANSFORMER:POWER	
W1	08405-6033	CABLE ASSY:COAXIAL	
W2		NOT ASSIGNED	
W3	08405-6027	CABLE ASSY:APC AMP.	
W4		NOT ASSIGNED	
W5	08405-6030	CABLE ASSY:"A" IF OUTPUT	
W6	08405-6029	CABLE ASSY:"B" IF OUTPUT	

See introduction to this section for ordering information

Table 6-1. Reference Designation Index (Cont'd)

Reference Designation	Part No.	Description #	Note
W7	08405-6031	CABLE ASSY: ISOLATION AMP.	
W8	08405-6031	CABLE ASSY: ISOLATION AMP.	
W9	08405-6033	CABLE ASSY: COAXIAL	
W10	08405-6036	CABLE ASSY: INPUT DELAY LINE	
W11	8120-1348	CABLE ASSY: POWER CORD	
XA3	1251-0194	CONNECTOR: PRINTED CIRCUIT 15-CONTACT	
XA4	1251-0194	CONNECTOR: PRINTED CIRCUIT 15-CONTACT	
XA5	1251-0135	CONNECTOR: BODY 15 PIN	
XA6	1251-0135	CONNECTOR: BODY 15 PIN	
XA7	1251-0135	CONNECTOR: BODY 15 PIN	
XA8	1251-0135	CONNECTOR: BODY 15 PIN	
XA9	1251-0135	CONNECTOR: BODY 15 PIN	
XA10	1251-0135	CONNECTOR: BODY 15 PIN	
XA11	1251-0135	CONNECTOR: BODY 15 PIN	
XA12	1251-0135	CONNECTOR: BODY 15 PIN	
XA13	1251-0194	CONNECTOR: PRINTED CIRCUIT 15-CONTACT	
XA14	1251-0194	CONNECTOR: PRINTED CIRCUIT 15-CONTACT	
XA15	1251-0194	CONNECTOR: PRINTED CIRCUIT 15-CONTACT	
XA16	1251-0135	CONNECTOR: BODY 15 PIN	
XA17		NOT ASSIGNED	
XA18	1251-0135	CONNECTOR: BODY 15 PIN	
XA19		NOT ASSIGNED	
XA25		NOT ASSIGNED	
XA26	1251-0135	CONNECTOR: BODY 15 PIN	
XF1	1400-0084	FUSEHOLDER: EXTRACTOR POST TYPE	
XF2	1400-0084	FUSEHOLDER: EXTRACTOR POST TYPE	
XF3	1400-0084	FUSEHOLDER: EXTRACTOR POST TYPE	
XQ1	1200-0041	SOCKET: TRANSISTOR	
XQ2	1200-0041	SOCKET: TRANSISTOR MISCELLANEOUS	
	0370-0112	KNOB: BLACK, RANGE AMPLITUDE RANGE & AMPL CHANNEL	
	0370-0113	KNOB: BLACK, SENSITIVITY PHASE RANGE & METER OFFSET	
	0370-0114	KNOB: RED W/ARROW 5/8" OD 1/8" SHAFT PHASE ZERO	
	0370-0115	KNOB: RED BAR 5/8 DIA 1/8 SHAFT PHASE, POLARITY	
	08405-6020	KNOB: FREQ RANGE, W/DIAL ATTACHED	
	5040-0404	HOLDER: PROBE	
	5020-0457	PROBE TIP	
	10213-62102	CLIP: GROUND	
	10216-60001	ISOLATOR	
	11576A	DIVIDER: 10:1	
	08405-6048	GROUND CLIP ASSY	
	8710-0084	NUT DRIVER: HEX 3-32" HEX OPENING	
	08405-2044	PROBE INSULATOR	

See introduction to this section for ordering information

Table 6-1. Reference Designation Index (Cont'd)

Reference Designation	Part No.	Description #	Note
CABINET PARTS			
1	5060-0734	FRAME ASSY:7 X 16 FM	
2	2530-0011	SCREW:SST FLAT HD 8-32 X 3/8	
	08405-0025	PANEL:FRONT	
3	0510-0004	FASTENER	
	5060-0767	FOOT ASSY:FM	
4	1490-0030	STAND:TILT	
5	5060-0776	KIT:7H RACK MOUNT	
6	08405-0011	SUB-PANEL:FRONT	
7	5060-0740	TOP COVER ASSY:16L FM	
	2530-0011	SCREW:SST FLAT HD 8-32 X 3/8	
8	08405-0015	PLATE-PANEL:RIGHT	
9	08405-0016	PLATE-PANEL:CENTER	
10	5060-0752	BOTTOM COVER ASSY:16L FM	
	2530-0011	SCREW:SST FLAT HD 8-32 X 3/8	
11	5060-0222	HANDLE ASSY-SIDE	
12	5060-0765	RETAINER-HANDLE ASSY.	
	2550-0013	SCREW:SST BH 8-32 X 5/16	
13	08405-0024	PANEL:REAR	
	2515-0017	SCREW:PAN HD PHIL DR 8-32 X 1/4	
14	08405-2021	EXTRUSION:TOP	
15	08405-2022	EXTRUSION:BOTTOM	
16	5000-0742	COVER:SIDE 7 X 16 SM	
	2370-0020	SCREW:SST FH PHIL DR 6-32 X 3/16	
17	5000-0052	PLATE:FLUTED ALUMINUM	

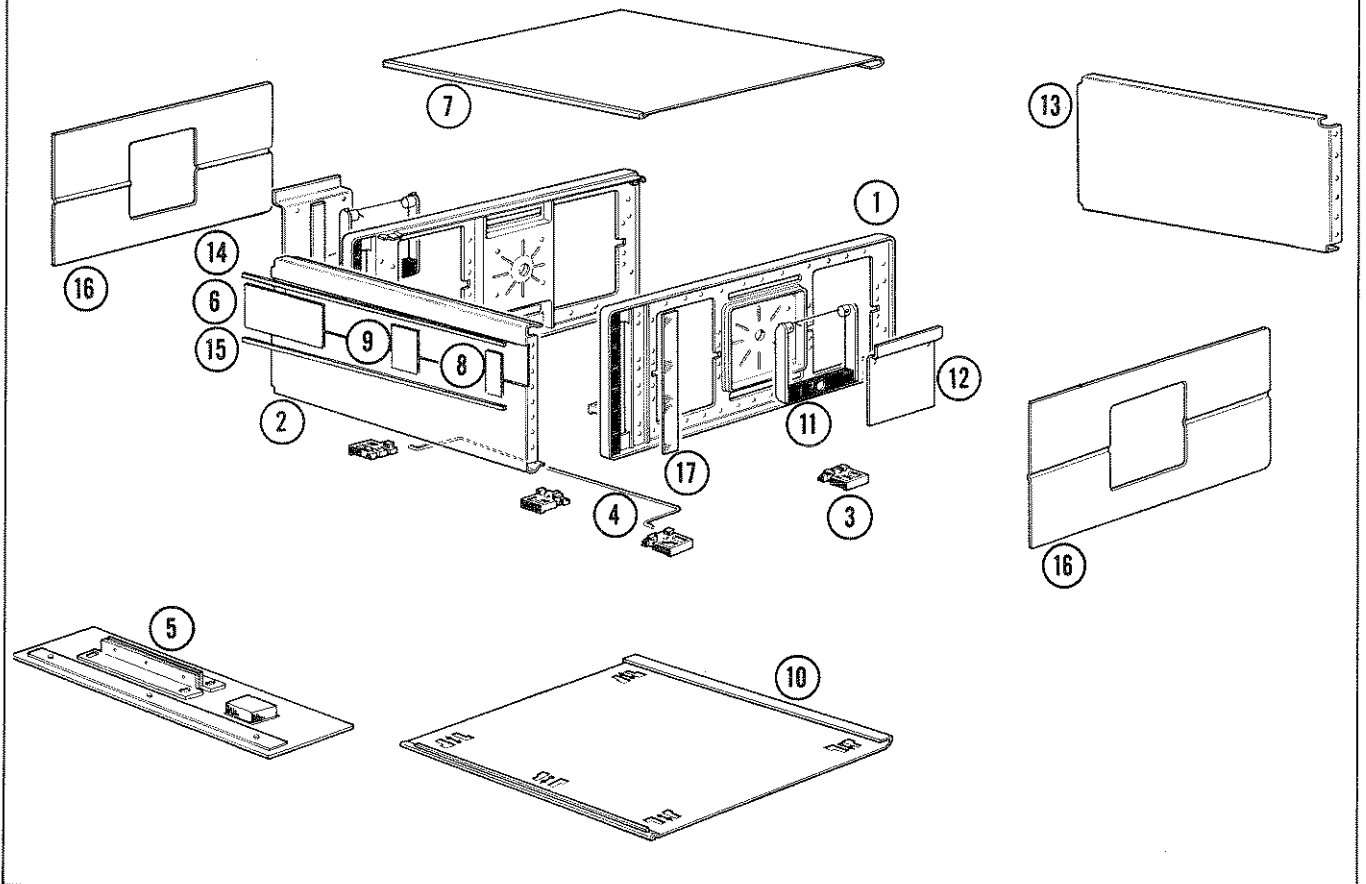

See introduction to this section for ordering information

Table 6-2. Replaceable Parts

Part No.	Description #	Mfr.	Mfr. Part No.	TQ
0140-0155	C:FXD MICA 1325 PF 1% 500VDCW	28480	0140-0155	1
0140-0156	C:FXD MICA 1500 PF 2%	28480	0140-0156	1
0140-0157	C:FXD MICA 1857 PF 1%	28480	0140-0157	1
0140-0170	C:FXD MICA 5600 PF 5% 300VDCW	28480	0140-0170	2
0140-0176	C:FXD MICA 100 PF 2%	28480	0140-0176	6
0140-0179	C:FXD MICA 1000 PF 2%	28480	0140-0179	4
0140-0180	C:FXD MICA 2000 PF 2%	28480	0140-0180	1
0140-0182	C:FXD MICA 5000 PF 2%	28480	0140-0182	1
0140-0193	C:FXD MICA 82 PF 5%	28480	0140-0193	1
0140-0194	C:FXD MICA 110 PF 5%	28480	0140-0194	2
0140-0197	C:FXD MICA 180 PF 5% 300 VDCW	04062	RDM15F181J3C	1
0140-0204	C:FXD MICA 47PF 5% NPD 500VDCW	04062	RDM15E470J5C	2
0140-0206	C:FXD MICA 270 PF 5%	28480	0140-0206	3
0140-0210	C:FXD MICA 270 PF 5%	28480	0140-0210	1
0140-0235	C:FXD MICA 2250PF 1% 300VDCW	14655	RDM20F122500F3C	1
0150-0019	C:FXD CER 1000 PF 20% 500VDCW	72982	327005X5U0102M	6
0150-0050	C:FXD CER 1000 PF 600VDCW	77630	08D	1
0150-0051	C:FXD CER 100 PF 600VDCW	84411	08D	1
0150-0069	C:FXD CER 1000 PF +100-20% 500VDCW	72982	801-010X5G0102Z	1
0150-0070	C:FXD CER 0.02 UF 20% 500VDCW	72982	821-011Z5U0203M	1
0150-0071	C:FXD CER 400 PF 5% 500VDCW	56289	19C294A-CDH	2
0150-0119	C:FXD CER 2 X 0.01 UF 20% 250VAC	56289	36C219A	1
0150-0121	C:FXD CER 0.1 UF +80-20% 50VDCW	56289	5C50B1S-CML	5
0160-0127	C:FXD CER 1.0 UF 20% 25VDCW	56289	5C13CS-CML	3
0160-0161	C:FXD MY 0.01 UF 10% 200VDCW	28480	0160-0161	1
0160-0163	C:FXD MY 0.033 UF 10% 200VDCW	28480	0160-0163	1
0160-0164	C:FXD MY 0.039 UF 10% 200VDCW	28480	0160-0164	1
0160-0168	C:FXD MY 0.1 UF 10% 200VDCW	28480	0160-0168	2
0160-0174	C:FXD CER 0.47 UF +80-20% 25VDCW	56289	5C11B7S-CML	6
0160-0301	C:FXD MY 0.012 UF 10% 200VDCW	28480	0160-0301	1
0160-0342	C:FXD MICA 800 PF 1% 300VDCW	04062	RDM15F801F3C	1
0160-2055	C:FXD CER 0.01 UF +80-20% 100VDCW	56289	C023F101F103ZS22	8
0160-2120	C:FXD MICA 0.01UF 1%	04062	RDM30F103F3C	4
0160-2127	C:FXD MICA 4600 PF 1%	28480	0160-2127	2
0160-2139	C:FXD CER 220 PF +80-20% 1000VDCW	91418	TYPE B	8
0160-2140	C:FXD CER 470 PF +80-20% 1000VDCW	91418	TYPE B	2
0160-2143	C:FXD CER 2000 PF +80-20% 1000VDCW	91418	TYPE B	2
0160-2146	C:FXD CER 0.02 UF +80-20% 100VDCW	91418	TA	1
0160-2211	C:FXD MICA 510 PF 5% 300VDCW	28480	0160-2211	2
0160-2257	C:FXD CER 10 PF 5% 500VDCW	72982	301-000-C0HD-100J	1
0160-2261	C:FXD CER 15 PF 5% 500VDCW	72982	301-NPG-15 PF	15
0160-2276	C:FXD MICA 2780 PF 2% 300VDCW	28480	0160-2276	1
0160-2277	C:FXD MICA 15000 PF 2%	28480	0160-2277	2
0160-2278	C:FXD MICA 34000 PF 2%	28480	0160-2278	1
0160-2279	C:FXD MICA 880 PF 2% 300VDCW	28480	0160-2279	1
0160-2917	C:FXD CER 0.05 UF +80-20% 100VDCW	84411	TYPE TA	2
0180-0050	C:FXD ELECT 40 UF +75-10% 50VDCW	28480	0180-0050	2
0180-0061	C:FXD ELECT 100UF +100%-10% 15VDCW	56289	30107G015DD4	1
0180-0098	C:FXD ELECT 100 UF 20% 20VDCW	28480	0180-0098	2
0180-0100	C:FXD ELECT 4.7 UF 10% 35VDCW	28480	0180-0100	81
0180-0116	C:FXD ELECT 6.8 UF 10% 35VDCW	28480	0180-0116	6
0180-0137	C:FXD ELECT 100 UF 20% 10VDCW	28480	0180-0137	3
0180-0138	C:FXD ELECT 100UF -10+100% 40VDCW	56289	D36254	3
0180-0195	C:FXD ELECT 0.33 UF 20% 35VDCW	28480	0180-0195	1

See introduction to this section for ordering information

Table 6-2. Replaceable Parts (Cont'd)

Part No.	Description #	Mfr.	Mfr. Part No.	TQ
0180-0230	C:FXD ELECT 1.0 UF 20% 50VDCW	28480	0180-0230	2
0180-0291	C:FXD ELECT 1.0 UF 10% 35VDCW	28480	0180-0291	1
0180-0369	C:FXD ELECT 2800 UF +75-10% 60VDCW	56289	D39823	2
0180-0374	C:FXD ELECT 10 UF 10% 20VDCW	28480	0180-0374	6
0180-1735	C:FXD ELECT 0.22 UF 10% 35VDCW	28480	0180-1735	1
0180-1746	C:FXD ELECT 15 UF 10% 20VDCW	28480	0180-1746	1
0180-2071	C:FXD ELECT 0.022 UF 10% 35VDCW	28480	0180-2071	2
0370-0112	KNOB:BLACK,RANGE	28480	0370-0112	1
0370-0113	KNOB:BLACK,SENSITIVITY	28480	0370-0113	1
0370-0114	KNOB:RED W/ARROW 5/8" OD 1/8" SHAFT	28480	0370-0114	1
0370-0115	KNOB:RED BAR 5/8 DIA 1/8 SHAFT	28480	0370-0115	1
0510-0004	FASTENER	46384	CL-832-2C	1
0683-1055	R:FXD COMP 1 MEGOHM 5% 1/4W	01121	CB 1055	1
0686-1055	R:FXD COMP 1 MEGOHM 5% 1/2W	01121	EB 1055	1
0698-0082	R:FXD MET FLM 464 OHM 1% 1/8W	28480	0698-0082	9
0698-0083	R:FXD MET FLM 1.96K OHM 1% 1/8W	28480	0698-0083	14
0698-0084	R:FXD MET FLM 2.15K OHM 1% 1/8W	28480	0698-0084	15
0698-0085	R:FXD MET FLM 2.61K OHM 1% 1/8W	28480	0698-0085	5
0698-3101	R:FXD MET FLM 2.87K OHM 1% 1/2W	28480	0698-3101	2
0698-3132	R:FXD MET FLM 261 OHM 1% 1/8W	28480	0698-3132	2
0698-3136	R:FXD MET FLM 17.8K OHM 1% 1/8W	28480	0698-3136	11
0698-3150	R:FXD MET FLM 2.37K OHM 1% 1/8W	28480	0698-3150	4
0698-3151	R:FXD MET FLM 2.87K OHM 1% 1/8W	28480	0698-3151	3
0698-3152	R:FXD MET FLM 3.48K OHM 1% 1/8W	28480	0698-3152	1
0698-3153	R:FXD MET FLM 3.83K OHM 1% 1/8W	28480	0698-3153	17
0698-3154	R:FXD MET FLM 4.22K OHM 1% 1/8W	28480	0698-3154	3
0698-3155	R:FXD MET FLM 4.64K OHM 1% 1/8W	28480	0698-3155	14
0698-3156	R:FXD MET FLM 14.7K OHM 1% 1/8W	28480	0698-3156	1
0698-3157	R:FXD MET FLM 19.6K OHM 1% 1/8W	28480	0698-3157	16
0698-3158	R:FXD MET FLM 23.7K OHM 1% 1/8W	28480	0698-3158	2
0698-3159	R:FXD MET FLM 26.1K OHM 1% 1/8W	28480	0698-3159	2
0698-3160	R:FXD MET FLM 31.6K OHM 1% 1/8W	28480	0698-3160	2
0698-3161	R:FXD MET FLM 38.3K OHM 1% 1/8W	28480	0698-3161	3
0698-3162	R:FXD MET FLM 46.4K OHM 1% 1/8W	28480	0698-3162	9
0698-3243	R:FXD MET FLM 178K OHM 1% 1/8W	28480	0698-3243	1
0698-3279	R:FXD MET FLM 4990 OHM 1% 1/8W	28480	0698-3279	1
0698-3400	R:FXD MET FLM 147 OHM 1% 1/2W	28480	0698-3400	1
0698-3403	R:FXD MET FLM 348 OHM 1% 1/2W	28480	0698-3403	1
0698-3405	R:FXD MET FLM 422 OHM 1% 1/2W	28480	0698-3405	3
0698-3406	R:FXD MET FLM 1.33K OHM 1% 1/2W	28480	0698-3406	6
0698-3407	R:FXD MET FLM 1.96K OHM 1% 1/2W	28480	0698-3407	2
0698-3420	R:FXD MET FLM 34.8K OHM 1% 1/2W	28480	0698-3420	1
0698-3431	R:FXD MET FLM 23.7 OHM 1% 1/8W	28480	0698-3431	2
0698-3437	R:FXD MET FLM 133 OHM 1% 1/8W	28480	0698-3437	8
0698-3438	R:FXD MET FLM 147 OHM 1% 1/8W	28480	0698-3438	7
0698-3440	R:FXD MET FLM 196 OHM 1% 1/8W	28480	0698-3440	14
0698-3441	R:FXD MET FLM 215 OHM 1% 1/8W	28480	0698-3441	5
0698-3442	R:FXD MET FLM 237 OHM 1% 1/8W	28480	0698-3442	3
0698-3444	R:FXD MET FLM 316 OHM 1% 1/8W	28480	0698-3444	3
0698-3445	R:FXD MET FLM 348 OHM 1% 1/8W	28480	0698-3445	2
0698-3446	R:FXD MET FLM 383 OHM 1% 1/8W	28480	0698-3446	1
0698-3447	R:FXD MET FLM 422 OHM 1% 1/8W	28480	0698-3447	1
0698-3449	R:FXD MET FLM 28.7K OHM 1% 1/8W	28480	0698-3449	6
0698-3450	R:FXD MET FLM 42.2K OHM 1% 1/8W	28480	0698-3450	2

See introduction to this section for ordering information

Table 6-2. Replaceable Parts (Cont'd)

Part No.	Description #	Mfr.	Mfr. Part No.	TQ
0698-3453	R:FXD MET FLM 196K OHM 1% 1/8W	28480	0698-3453	2
0698-3454	R:FXD MET FLM 215K OHM 1% 1/8W	28480	0698-3454	1
0698-3455	R:FXD MET FLM 261K OHM 1% 1/8W	28480	0698-3455	1
0698-3459	R:FXD MET FLM 383K OHM 1% 1/8W	28480	0698-3459	1
0698-3460	R:FXD MET FLM 422K OHM 1% 1/8W	28480	0698-3460	2
0698-4037	R:FXD MET FLM 46.4 OHM 1% 1/8W	28480	0698-4037	2
0698-4084	R:FXD MET FLM 19.2 OHM 1% 1/8W	28480	0698-4084	1
0698-4085	R:FXD MET FLM 20.8 OHM 1% 1/8W	28480	0698-4085	1
0698-4086	R:FXD MET FLM 22.6 OHM 1% 1/8W	28480	0698-4086	1
0698-4087	R:FXD MET FLM 24.6 OHM 1% 1/8W	28480	0698-4087	1
0698-4088	R:FXD MET FLM 27 OHM 1% 1/8W	28480	0698-4088	1
0698-4089	R:FXD MET FLM 29.7 OHM 1% 1/8W	28480	0698-4089	1
0698-4090	R:FXD MET FLM 32.8 OHM 1% 1/8W	28480	0698-4090	1
0698-4091	R:FXD MET FLM 40.80OHM 1% 1/8W	28480	0698-4091	1
0698-4092	R:FXD MET FLM 45.9 OHM 1% 1/8W	28480	0698-4092	1
0698-4093	R:FXD MET FLM 52 OHM 1% 1/8W	28480	0698-4093	1
0698-4094	R:FXD MET FLM 59.5 OHM 1% 1/8W	28480	0698-4094	1
0698-4095	R:FXD MET FLM 68.6 OHM 1% 1/8W	28480	0698-4095	1
0698-4096	R:FXD MET FLM 80.2 OHM 1% 1/8W	28480	0698-4096	1
0698-4097	R:FXD MET FLM 94.8 OHM 1% 1/8W	28480	0698-4097	1
0698-4099	R:FXD MET FLM 139 OHM 1% 1/8W	28480	0698-4099	1
0698-4100	R:FXD MET FLM 1.26K OHM 1% 1/8W	28480	0698-4100	2
0698-4101	R:FXD MET FLM 1.85K OHM 1% 1/8W	28480	0698-4101	2
0698-4102	R:FXD MET FLM 2.06K OHM 1% 1/8W	28480	0698-4102	2
0698-4315	R:FXD COMP 430 OHM 5% 1/2W	28480	0698-4315	1
0698-4349	R:FXD MET FLM 99.5 OHM 1% 1/8W	28480	0698-4349	2
0698-5847	R:FXD MET FLM 2150 OHM 0.5% 1/8W	28480	0698-5847	2
0698-5848	R:FXD MET FLM 215 OHM 0.5% 1/8W	28480	0698-5848	2
0698-5850	R:FXD MET FLM 681 OHM 0.5% 1/8W	28480	0698-5850	2
0698-5851	R:FXD MET FLM 6.81K OHM 0.5% 1/8W	28480	0698-5851	2
0757-0077	R:FXD FLM 1.2K OHM 2% 1/4W	28480	0757-0077	2
0757-0123	R:FXD MET FLM 34.8K OHM 1% 1/8W	28480	0757-0123	3
0757-0198	R:FXD MET FLM 100 OHM 1% 1/2W	28480	0757-0198	3
0757-0199	R:FXD MET FLM 21.5K OHM 1% 1/8W	28480	0757-0199	4
0757-0200	R:FXD MET FLM 5.62K OHM 1% 1/8W	28480	0757-0200	7
0757-0274	R:FXD MET FLM 1.21K OHM 1% 1/8W	28480	0757-0274	1
0757-0275	R:FXD MET FLM 113 OHM 1% 1/8W	28480	0757-0275	1
0757-0278	R:FXD MET FLM 1.78K OHM 1% 1/8W	28480	0757-0278	2
0757-0279	R:FXD MET FLM 3.16K OHM 1% 1/8W	28480	0757-0279	6
0757-0280	R:FXD MET FLM 1K OHM 1% 1/8W	28480	0757-0280	19
0757-0288	R:FXD MET FLM 9.09K OHM 1% 1/8W	28480	0757-0288	4
0757-0289	R:FXD MET FLM 13.3K OHM 1% 1/8W	28480	0757-0289	3
0757-0290	R:FXD MET FLM 6.19K OHM 1% 1/8W	28480	0757-0290	3
0757-0294	R:FXD MET FLM 17.8 OHM 1% 1/8W	28480	0757-0294	4
0757-0316	R:FXD MET FLM 42.2 OHM 1% 1/8W	28480	0757-0316	1
0757-0317	R:FXD MET FLM 1.33K OHM 1% 1/8W	28480	0757-0317	3
0757-0346	R:FXD MET FLM 10 OHM 1% 1/8W	28480	0757-0346	2
0757-0351	R:FXD MET FLM 402 OHM 1% 1/4W	28480	0757-0351	1
0757-0390	R:FXD MET FLM 36.5 OHM 1% 1/8W	28480	0757-0390	1
0757-0394	R:FXD MET FLM 51.1 OHM 1% 1/8W	28480	0757-0394	9
0757-0398	R:FXD MET FLM 75 OHM 1% 1/8W	28480	0757-0398	2
0757-0401	R:FXD MET FLM 100 OHM 1% 1/8W	28480	0757-0401	6
0757-0402	R:FXD MET FLM 110 OHM 1% 1/8W	28480	0757-0402	2
0757-0403	R:FXD MET FLM 121 OHM 1% 1/8W	28480	0757-0403	1

See introduction to this section for ordering information

Table 6-2. Replaceable Parts (Cont'd)

Part No.	Description #	Mfr.	Mfr. Part No.	TQ
0757-0405	R:FXD MET FLM 162 OHM 1% 1/8W	28480	0757-0405	5
0757-0406	R:FXD MET FLM 182 OHM 1% 1/8W	28480	0757-0406	1
0757-0416	R:FXD MET FLM 511 OHM 1% 1/8W	28480	0757-0416	1
0757-0419	R:FXD MET FLM 681 OHM 1% 1/8W	28480	0757-0419	1
0757-0420	R:FXD MET FLM 750 OHM 1% 1/8W	28480	0757-0420	2
0757-0422	R:FXD MET FLM 909 OHM 1% 1/8W	28480	0757-0422	1
0757-0424	R:FXD MET FLM 1.10K OHM 1% 1/8W	28480	0757-0424	12
0757-0428	R:FXD MET FLM 1.62K OHM 1% 1/8W	28480	0757-0428	7
0757-0438	R:FXD MET FLM 5.11K OHM 1% 1/8W	28480	0757-0438	9
0757-0439	R:FXD MET FLM 6.81K OHM 1% 1/8W	28480	0757-0439	5
0757-0440	R:FXD MET FLM 7.50K OHM 1% 1/8W	28480	0757-0440	4
0757-0441	R:FXD MET FLM 8.25K OHM 1% 1/8W	28480	0757-0441	4
0757-0442	R:FXD MET FLM 10.0K OHM 1% 1/8W	28480	0757-0442	13
0757-0443	R:FXD MET FLM 11.0K OHM 1% 1/8W	28480	0757-0443	2
0757-0444	R:FXD MET FLM 12.1K OHM 1% 1/8W	28480	0757-0444	3
0757-0447	R:FXD MET FLM 16.2K OHM 1% 1/8W	28480	0757-0447	4
0757-0458	R:FXD MET FLM 51.1K OHM 1% 1/8W	28480	0757-0458	1
0757-0459	R:FXD MET FLM 56.2K OHM 1% 1/8W	28480	0757-0459	3
0757-0460	R:FXD MET FLM 61.9K OHM 1% 1/8W	28480	0757-0460	1
0757-0461	R:FXD MET FLM 68.1K OHM 1% 1/8W	28480	0757-0461	1
0757-0462	R:FXD MET FLM 75.0K OHM 1% 1/8W	28480	0757-0462	4
0757-0464	R:FXD MET FLM 90.9K OHM 1% 1/8W	28480	0757-0464	1
0757-0465	R:FXD MET FLM 100K OHM 1% 1/8W	28480	0757-0465	10
0757-0466	R:FXD MET FLM 110K OHM 1% 1/8W	28480	0757-0466	5
0757-0467	R:FXD MET FLM 121K OHM 1% 1/8W	28480	0757-0467	2
0757-0706	R:FXD MET FLM 51.1 OHM 1% 1/4W	28480	0757-0706	1
0757-0815	R:FXD MET FLM 562 OHM 1% 1/2W	28480	0757-0815	2
0757-0833	R:FXD MET FLM 5.11K OHM 1% 1/2W	28480	0757-0833	1
0757-1078	R:FXD MET FLM 1.47K OHM 1% 1/2W	28480	0757-1078	2
0757-1094	R:FXD MET FLM 1.47K OHM 1% 1/8W	28480	0757-1094	6
0766-0024	R:FXD MET FLM 260 OHM 2% 3W	28480	0766-0024	1
0811-0040	R:FXD WW 1 OHM 1% 5W	28480	0811-0040	4
0811-1637	R:FXD WW 344.3 OHM 0.1% 1/3W	28480	0811-1637	1
0811-1638	R:FXD WW 344.8 OHM 0.1% 1/8W	28480	0811-1638	1
0811-1639	R:FXD WW 477.6 OHM 0.1% 1/8W	28480	0811-1639	1
0811-1640	R:FXD WW 1111 OHM 0.1% 1/8W	28480	0811-1640	1
0811-1641	R:FXD WW 6710 OHM 0.1% 1/8W	28480	0811-1641	2
0811-1642	R:FXD WW 8825 OHM 0.1% 1/8W	28480	0811-1642	1
0813-0017	R:FXD WW 5 OHM 10% 5W	28480	0813-0017	1
0816-0010	R:FXD WW 12 OHM 10% 10W	28480	0816-0010	1
1120-0361	METER:RMS VOLTS	28480	1120-0361	1
1120-0394	METER:DEGREES	28480	1120-0394	1
1120-1466	METER:RMS VOLTS LIN LOG OPT 02	28480	1120-1466	1
1200-0041	SOCKET:TRANSISTOR	71785	133-32-10-013	2
1200-0077	INSULATOR:TRANSISTOR, MICA	16037	#112	2
1205-0012	HEAT DISSIPATOR:SEMICONDUCTOR	28480	1205-0012	1
1205-0018	HEAT SINK	05820	NF-203	1
1205-0202	HEAT DISSIPATOR:SEMICONDUCTOR	28480	1205-0202	4
1250-0083	CONNECTOR:BNC	28480	1250-0083	2
1251-0135	CONNECTOR:BODY 15 PIN	28480	1251-0135	11
1251-0194	CONNECTOR:PRINTED CIRCUIT 15-CONTACT	28480	1251-0194	5
1251-2357	CONNECTOR:POWER 3-PIN MALE	82389	EAC-301	1
1400-0084	FUSEHOLDER:EXTRACTOR POST TYPE	79515	342014	3
1450-0708	LIGHT:INDICATOR AMBER	28480	1450-0708	1

See introduction to this section for ordering information

Table 6-2. Replaceable Parts (Cont'd)

Part No.	Description #	Mfr.	Mfr. Part No.	TQ
1490-0030	STAND:TILT	28480	1490-0030	1
1853-0001	TRANSISTOR:PNP SILICON 30V 900MW	28480	1853-0001	2
1853-0009	TRANSISTOR:SILICON PNP	28480	1853-0009	12
1853-0010	TRANSISTOR:SILICON PNP	28480	1853-0010	3
1853-0020	TRANSISTOR:SILICON PNP	28480	1853-0020	4
1854-0003	TRANSISTOR:NPN SILICON	28480	1854-0003	4
1854-0005	TRANSISTOR:SILICON NPN 2N708	02735	2N708	10
1854-0020	TRANSISTOR:NPN SILICON	28480	1854-0020	2
1854-0035	TRANSISTOR:NPN SILICON	28480	1854-0035	1
1854-0039	TRANSISTOR:SILICON NPN 2N3053	02735	2N3053	2
1854-0063	TRANSISTOR:NPN SILICON 2N3055	02735	2N3055	2
1854-0071	TRANSISTOR:SILICON NPN	28480	1854-0071	47
1854-0371	TRANSISTOR:SILICON NPN	28480	1854-0371	4
1901-0025	DIODE:SILICON 100WV 100MA	28480	1901-0025	3
1901-0026	DIODE:SILICON 0.75A 200 PIV	28480	1901-0026	4
1901-0033	DIODE:SILICON 100MA 180WV	28480	1901-0033	6
1901-0040	DIODE:SILICON 30MA 30WV	07263	FDG1088	35
1901-0047	DIODE JUNCTION:SILICON 20PIV	28480	1901-0047	1
1901-0441	DIODE:STEP RECOVERY SILICON 90-160NS	28480	1901-0441	1
1902-0018	DIODE BREAKDOWN:11.7V 5%	04713	1N941	2
1902-0025	DIODE BREAKDOWN:10.0V 5% 400MW	28480	1902-0025	1
1902-0048	DIODE BREAKDOWN:6.81V	28480	1902-0048	1
1902-0057	DIODE BREAKDOWN:6.49V	28480	1902-0057	2
1902-0062	DIODE BREAKDOWN:3.75V	28480	1902-0062	2
1902-0126	DIODE BREAKDOWN:2.61V 5%	28480	1902-0126	1
1902-0184	DIODE BREAKDOWN:SILICON 16.2V 5%	28480	1902-0184	2
2100-0024	R:VAR COMP 1000 OHM 10% LIN 2W	28480	2100-0024	1
2100-0328	R:VAR WW 500 OHM 10% LIN 1W	28480	2100-0328	2
2100-0942	R:VAR FLM 50K OHM 20% 3/4W	28480	2100-0942	3
2100-1658	R:VAR WW 2K OHM 10% 1W	28480	2100-1658	2
2100-1756	R:VAR WW 200 OHM 5% 2W	28480	2100-1756	1
2100-1757	R:VAR WW 500 OHM 5% 1W	28480	2100-1757	2
2100-1760	R:VAR WW 5K OHM 5% 1W	28480	2100-1760	3
2100-1761	R:VAR WW 10K OHM 5% 1W	28480	2100-1761	3
2110-0001	FUSE:1A 250V	75915	312001	1
2110-0202	FUSE:0.50A 250V	28480	2110-0202	3
2140-0244	LAMP:GLOW T-2 BULB 1.0M AMP 95VAC	87034	A1H	1
2370-0020	SCREW:SST FH PHIL DR 6-32 X 3/16	00000	08D	1
2515-0017	SCREW:PAN HD PHIL DR 8-32 X 1/4	00000	08D	1
2530-0011	SCREW:SST FLAT HD 8-32 X 3/8	78189	08D#	3
2550-0013	SCREW:SST BH 8-32 X 5/16	28480	2550-0013	1
3100-1831	SWITCH:ROTARY	28480	3100-1831	1
3100-1832	SWITCH:ROTARY	28480	3100-1832	1
3100-1833	SWITCH:ROTARY	28480	3100-1833	1
3100-1834	SWITCH:ROTARY	28480	3100-1834	1
3100-1835	SWITCH:ROTARY	28480	3100-1835	1
3101-0901	SWITCH:PUSHBUTTON 3PDT	82389	NF-4009	1
3101-1234	SWITCH:SLIDE DPDT	82389	11A-1242	1
3101-1248	SWITCH:PUSHBUTTON SPDT	87034	53-55480-121/A1H	1
5000-0052	PLATE:FLUTED ALUMINUM	28480	5000-0052	1
5000-C742	COVER:SIDE 7 X 16 SM	28480	5000-0742	1
5020-0457	PROBE TIP	28480	5020-0457	3
5020-2045	CARD EXTRACTOR	28480	5020-2045	10
5040-0218	COUPLER:SWITCH SHAFT	28480	5040-0218	1
5040-0404	HOLDER:PROBE	28480	5040-0404	1
5060-0222	HANDLE ASSY:SIDE	28480	5060-0222	1
5060-0734	FRAME ASSY:7 X 16 FM	28480	5060-0734	1

See introduction to this section for ordering information

Table 6-2. Replaceable Parts (Cont'd)

Part No.	Description #	Mfr.	Mfr. Part No.	TQ
5060-C740	TOP COVER ASSY:16L FM	28480	5060-0740	1
5060-C752	BOTTOM COVER ASSY:16L FM	28480	5060-0752	1
5060-C765	RETAINER-HANDLE ASSY.	28480	5060-0765	1
5060-C767	FOOT ASSY:FM	28480	5060-0767	1
5060-C776	KIT:7H RACK MOUNT	28480	5060-0776	1
8120-1348	CABLE ASSY:POWER CORD	28480	8120-1348	1
8710-0084	NUT DRIVER:HEX 3-32"HEX OPENING	96508	P-3	1
9100-1610	CCIL:MOLDED CHOKE 0.15 UH 20%	28480	9100-1610	2
9100-1628	CCIL:MOLDED CHOKE 43.0 UH 5%	28480	9100-1628	1
9100-1653	CCIL:MOLDED CHOKE 910.0 UH 5%	28480	9100-1653	1
9100-1698	TRANSFORMER:PULSE	28480	9100-1698	1
9100-1706	TRANSFORMER:POWER	28480	9100-1706	1
9100-1718	CCIL:VAR	28480	9100-1718	2
9100-1719	CCIL:VAR	28480	9100-1719	2
9140-C072	CCIL:RF 5000 UH 10%	95265	SA5000-1	1
9140-C096	CCIL:FXD RF 1 UH	28480	9140-C096	8
9140-C114	CCIL:FXD RF 10 UH	28480	9140-0114	6
9140-0118	CCIL:FXD 500 UH 5%	28480	9140-0118	1
9140-0120	CCIL:FXD 0.1 UH 20%	28480	9140-0120	2
9140-0138	COIL/CHOKE 180 UH 5%	28480	9140-0138	3
9140-0181	CCIL:FXD RF 22UH 5%	78526	12201M	1
00187-42106	RING:IDENT BLUE	28480	00187-42106	1
08405-0011	SUB-PANEL:FRONT	28480	08405-0011	1
08405-0013	COVER:SWITCH	28480	08405-0013	2
08405-0014	PLATE:SWITCH COVER	28480	08405-0014	4
08405-0015	PLATE:PANEL, RIGHT	28480	08405-0015	1
08405-0016	PLATE:PANEL, CENTER	28480	08405-0016	1
08405-0024	PANEL:REAR	28480	08405-0024	1
08405-0025	PANEL:FRONT	28480	08405-0025	1
08405-2021	EXTRUSION:TOP	28480	08405-2021	1
08405-2022	EXTRUSION:BOTTOM	28480	08405-2022	1
08405-2044	PROBE INSULATOR	28480	08405-2044	1
08405-2032	RING:IDENT WHITE	28480	08405-2032	1
08405-6002	BOARD ASSY:SAMPLER	28480	08405-6002	2
08405-6003	BOARD ASSY:ISOLATION AMP.	28480	08405-6003	2
08405-6005	BOARD ASSY:PHASE SHIFTER	28480	08405-6005	1
08405-6006	BOARD ASSY:180 DEG. SWITCH	28480	08405-6006	1
08405-6009	BOARD ASSY:VOLTMETER	28480	08405-6009	1
08405-6010	BOARD ASSY:APC AMPLIFIER	28480	08405-6010	1
08405-6012	BOARD ASSY:SEARCH	28480	08405-6012	1
08405-6013	BOARD ASSY:EQUALIZER	28480	08405-6013	1
08405-6014	BOARD ASSY:VTD	28480	08405-6014	1
08405-6015	BOARD ASSY:PULSE GENERATOR	28480	08405-6015	1
08405-6016	BOARD ASSY:POWER SUPPLY	28480	08405-6016	1
08405-6017	DELAY LINE ASSY	28480	08405-6017	1
08405-6018	BOARD ASSY:EXTENDER	28480	08405-6018	1
08405-6020	KNCB:FREQ RANGE,W/DIAL ATTACHED	28480	08405-6020	1
08405-6024	SWITCH ASSY:PHASE RANGE	28480	08405-6024	1
08405-6027	CABLE ASSY:APC AMP.	28480	08405-6027	1
08405-6028	CABLE ASSY	28480	08405-6028	1
08405-6029	CABLE ASSY:"B" IF OUTPUT	28480	08405-6029	1
08405-6030	CABLE ASSY:"A" IF OUTPUT	28480	08405-6030	1
08405-6031	CABLE ASSY:ISOLATION AMP.	28480	08405-6031	2
08405-6032	CABLE ASSY:COAXIAL	28480	08405-6032	2
08405-6033	CABLE ASSY:COAXIAL	28480	08405-6033	2

See introduction to this section for ordering information

Table 6-2. Replaceable Parts (Cont'd)

Part No.	Description #	Mfr.	Mfr. Part No.	TQ
08405-6034	CABLE ASSY:PULSE GENERATOR	28480	08405-6034	1
08405-6035	CABLE ASSY:OUTPUT DELAY LINE	28480	08405-6035	1
08405-6036	CABLE ASSY:INPUT DELAY LINE	28480	08405-6036	1
08405-6037	CABLE ASSY	28480	08405-6037	1
08405-6038	CABLE ASSY	28480	08405-6038	1
08405-6039	CABLE ASSY:SHORT AMP RANGE	28480	08405-6039	1
08405-6040	CABLE ASSY:MED AMP RANGE	28480	08405-6040	1
08405-6041	CABLE ASSY:LONG AMP RANGE	28480	08405-6041	1
08405-6042	SWITCH ASSY:CHANNEL	28480	08405-6042	1
08405-6047	CABLE ASSY:SPECIAL COAX	28480	08405-6047	2
08405-6048	GROUND CLIP ASSY	28480	08405-6048	1
08405-6051	SWITCH ASSY:AMPLITUDE RANGE	28480	08405-6051	1
08405-6052	SWITCH ASSY:PHASE METER OFFSET	28480	08405-6052	1
08405-6053	SWITCH ASSY:FREQ. RANGE	28480	08405-6053	1
08405-6054	BOARD ASSY:PROBE	28480	08405-6054	2
08405-6055	HOUSING ASSY:PROBE	28480	08405-6055	2
08405-6057	BOARD ASSY:IF SAMPLER	28480	08405-6057	1
08405-6058	BOARD ASSY:PHASE METER	28480	08405-6058	1
08405-8001	TRANSFORMER:BALUN	28480	08405-8001	2
08405-8002	TRANSFORMER:IF	28480	08405-8002	2
08405-8003	TRANSISTOR:NPN SILICON SELECTED	28480	08405-8003	2
08405-8004	DIODES:SILICON MATCHED PAIR	28480	08405-8004	7
10213-62102	CLIP:GROUND	28480	10213-62102	1
10216-60001	ISOLATOR	28480	10216-60001	1
11576 A	DIVIDER 10:1	28480	11576A	1

See introduction to this section for ordering information

**TABLE 6-3.
CODE LIST OF MANUFACTURERS**

The following code numbers are from the Federal Supply Code for Manufacturers Cataloging Handbooks H4-1 (Name to Code) and H4-2 (Code to Name) and their latest supplements. The date of revision and the date of the supplements used appear at the bottom of each page. Alphabetical codes have been arbitrarily assigned to suppliers not appearing in the H4 Handbooks.

Code No.	Manufacturer	Address	Code No.	Manufacturer	Address	Code No.	Manufacturer	Address
00000	U. S. A. Common	Any supplier of U. S.	05245	Components Corp.	Chicago, Ill.	09145	Tech. Ind. Inc. Atohm Elect.	Burbank, Calif.
00136	McCoy Electronics	Mount Holly Springs, Pa.	05277	Westinghouse Electric Corp.		09250	Electro Assemblies, Inc.	Chicago, Ill.
00213	Sage Electronics Corp.	Rochester, N. Y.		Semi-Conductor Dept.	Youngwood, Pa.	09353	C & K Components Inc.	Newton, Mass.
00287	Cemco Inc.	Danielson, Conn.	05347	Ultronix, Inc.	San Mateo, Calif.	09569	Mallory Battery Co. of	
00334	Humidial	Colton, Calif.	05397	Union Carbide Corp., Elect. Div.			Canada, Ltd.	Toronto, Ontario, Canada
00348	Microtron Co., Inc.	Valley Stream, N. Y.			New York, N. Y.	09922	Burdry Corp.	Norwalk, Conn.
00373	Garlock Inc.	Cherry Hill, N. J.	05574	Viking Ind. Inc.	Canoga Park, Calif.	10214	General Transistor Western Corp.	
00656	Aerovox Corp.	New Bedford, Mass.	05593	Icove Electro-Plastics Inc.	Sunnyvale, Calif.			Los Angeles, Calif.
00779	Amp. Inc.	Harrisburg, Pa.	05616	Cosmo Plastic		10411	Ti-Tai, Inc.	Berkeley, Calif.
00781	Aircraft Radio Corp.	Boonton, N. J.		(c/o Electrical Spec. Co.)	Cleveland, Ohio	10646	Carborundum Co.	Niagara Falls, N. Y.
00815	Northern Engineering Laboratories, Inc.	Burlington, Wis.	05624	Barber Colman Co.	Rockford, Ill.	11236	CTS of Berne, Inc.	Berne, Ind.
00853	Sangamo Electric Co., Pickens Div.		05728	Tiffen Optical Co.		11237	Chicago Telephone of California, Inc.	
		Pickens, S. C.			Roslyn Heights, Long Island, N. Y.			So. Pasadena, Calif.
00866	Goe Engineering Co.	City of Industry, Cal.	05729	Metro-Tel Corp.	Westbury, N. Y.	11242	Bay State Electronics Corp.	Waltham, Mass.
00891	Carl E. Holmes Corp.	Los Angeles, Calif.	05783	Stewart Engineering Co.	Santa Cruz, Calif.	11312	Teledyne Inc., Microwave Div.	Palo Alto, Calif.
00929	Microfab Inc.	Livingston, N. J.	05820	Wakefield Engineering Inc.	Wakefield, Mass.	11314	National Seal	Downey, Calif.
01002	General Electric Co., Capacitor Dept.		06004	Bassick Co., Div. of Stewart Warner Corp.		11453	Precision Connector Corp.	Jamaica, N. Y.
		Hudson Falls, N. Y.			Bridgeport, Conn.	11534	Duncan Electronics Inc.	Costa Mesa, Calif.
01009	Alden Products Co.	Brockton, Mass.	06090	Raychem Corp.	Redwood City, Calif.	11711	General Instrument Corp., Semiconductor	
01121	Allen Bradley Co.	Milwaukee, Wis.	06175	Bausch and Lomb Optical Co.	Rochester, N. Y.		Div., Products Group	Newark, N. J.
01255	Litton Industries, Inc.	Beverly Hills, Calif.	06402	E. T. A. Products Co. of America	Chicago, Ill.	11717	Imperial Electronic, Inc.	Buena Park, Calif.
01281	TRW Semiconductors, Inc.	Lawndale, Calif.	06540	Anatom Electronic Hardware Co., Inc.		11870	Melabs, Inc.	Palo Alto, Calif.
01295	Texas Instruments, Inc., Transistor Products Div.				New Rochelle, N. Y.	12040	National Semiconductor	Danbury, Conn.
		Dallas, Texas	06555	Beede Electrical Instrument Co., Inc.		12136	Philadelphia Handle Co.	Camden, N. J.
01349	The Alliance Mfg. Co.	Alliance, Ohio			Penacook, N. H.	12361	Grove Mfg. Co., Inc.	Shady Grove, Pa.
01589	Pacific Relays, Inc.	Van Nuys, Calif.	06666	General Devices Co., Inc.	Indianapolis, Ind.	12574	Gulton Ind. Inc. Data System Div.	Albuquerque, N. M.
01670	Gudebrod Bros. Silk Co.	New York, N. Y.	06751	Components Inc., Ariz. Div.	Phoenix, Ariz.			Dover, N. H.
01930	Amerock Corp.	Rockford, Ill.	06812	Torrington Mfg. Co., West Div.		12697	Glarostat Mfg. Co.	Dover, N. H.
01961	Pulse Engineering Co.	Santa Clara, Calif.			Van Nuys, Calif.	12728	Elmar Filter Corp.	W. Haven, Conn.
02114	Ferroxcube Corp. of America	Saugerties, N. Y.	06980	Varian Assoc. Eimac Div.	San Carlos, Calif.	12859	Nippon Electric Co., Ltd.	Tokyo, Japan
02116	Wheelock Signals, Inc.	Long Branch, N. J.	07088	Kelvin Electric Co.	Van Nuys, Calif.	12881	Metex Electronics Corp.	Clark, N. J.
02286	Cole Rubber and Plastics Inc.	Sunnyvale, Calif.	07126	Digitran Co.	Pasadena, Calif.	12930	Delta Semiconductor Inc.	Newport Beach, Calif.
02560	Amphenol-Borg Electronics Corp.	Broadview, Ill.	07137	Transistor Electronics Corp.	Minneapolis, Minn.	12954	Dickson Electronics Corp.	Scottsdale, Arizona
02735	Radio Corp. of America, Semiconductor and Materials Div.		07138	Westinghouse Electric Corp. Electronic Tube Div.		13103	Thermolloy	Dallas, Texas
		Somerville, N. J.			Elmira, N. Y.	13396	Telefunken (GmbH)	Hanover, Germany
02771	Vocaine Co. of America, Inc.		07149	Filmohm Corp.	New York, N. Y.	13835	Midland-Wright Div. of Pacific Industries, Inc.	
		Old Saybrook, Conn.	07233	Cinch-Graphik Co.	City of Industry, Calif.			Kansas City, Kansas
02777	Hopkins Engineering Co.	San Fernando, Calif.	07256	Silicon Transistor Corp.	Carle Place, N. Y.	14099	Sem-Tech	Newbury Park, Calif.
02875	Hudson Tool & Die Co.	Newark, N. J.	07261	Avnet Corp.	Culver City, Calif.	14193	Calif. Resistor Corp.	Santa Monica, Calif.
03508	G. E. Semiconductor Prod. Dept.	Syracuse, N. Y.	07263	Fairchild Camera & Inst. Corp.		14298	American Components, Inc.	Conshohocken, Pa.
03705	Apex Machine & Tool Co.	Dayton, Ohio			Mountain View, Calif.	14433	ITT Semiconductor, A Div. of Int. Telephone & Telegraph Corp.	West Palm Beach, Fla.
03797	Eldema Corp.	Compton, Calif.	07322	Minnesota Rubber Co.	Minneapolis, Minn.	14493	Hewlett-Packard Company	Loveland, Colo.
03818	Parker Seal Co.	Los Angeles, Calif.	07387	Bitcher Corp., The	Monterey Park, Calif.	14655	Cornell Dubilier Electric Corp.	Newark, N. J.
03877	Transitron Electric Corp.	Wakefield, Mass.	07397	Sylvania Elect. Prod. Inc., Mt. View Operations		14674	Corning Glass Works	Corning, N. Y.
03888	Pyrofilm Resistor Co., Inc.	Cedar Knolls, N. J.			Mountain View, Calif.	14752	Electro Cube Inc.	San Gabriel, Calif.
03954	Singer Co., Diehl Div.		07700	Technical Wire Products Inc.	Cranford, N. J.	14960	Williams Mfg. Co.	San Jose, Calif.
		Sumerville, N. J.	07829	Bodine Elect. Co.	Chicago, Ill.	15203	Webster Electronics Co.	New York, N. Y.
04009	Arrow, Hart and Hegeman Elect. Co.		07910	Continental Device Corp.	Hawthorne, Calif.	15287	Scionics Corp.	Northridge, Calif.
		Hartford, Conn.	07933	Raytheon Mfg. Co., Semiconductor Div.		15291	Adjustable Bushing Co.	N. Hollywood, Calif.
04013	Taurus Corp.	Lambertville, N. J.			Mountain View, Calif.	15558	Micron Electronics	
04062	Arco Electronic Inc.	Great Neck, N. Y.	07980	Hewlett-Packard Co., Boonton Radio Div.				Garden City, Long Island, N. Y.
04222	Hi-Q Division of Aerovox	Myrtle Beach, S. C.			Rockaway, N. J.	15566	Amprobe Inst. Corp.	Lynbrook, N. Y.
04354	Precision Paper Tube Co.	Wheeling, Ill.	08145	U. S. Engineering Co.	Los Angeles, Calif.	15631	Cabletronics	Costa Mesa, Calif.
04404	Dymec Division of Hewlett-Packard Co.		08289	Blinn, Delbert Co.	Pomona, Calif.	15772	Twentieth Century Coil Spring Co.	
		Palo Alto, Calif.	08358	Burgess Battery Co.				Santa Clara, Calif.
04651	Sylvania Electric Products, Microwave Device Div.				Niagara Falls, Ontario, Canada	15891	Fenwal Elect. Inc.	Framingham, Mass.
		Mountain View, Calif.	08524	Deutsch Fastener Corp.	Los Angeles, Calif.	15818	Amelco Inc.	Mt. View, Calif.
04673	Dakota Engr. Inc.	Culver City, Calif.	08664	Bristol Co., The	Waterbury, Conn.	16037	Spruce Pine Mica Co.	Spruce Pine, N. C.
04713	Motorola, Inc., Semiconductor Prod. Div.		08717	Sloan Company	Sun Valley, Calif.	16179	Omni-Spectra Inc.	Farmington, Mich.
		Phoenix, Arizona	08718	ITT Cannon Electric Inc., Phoenix Div.		16352	Computer Diode Corp.	Lodi, N. J.
04732	Filttron Co., Inc. Western Div.				Phoenix, Arizona	16585	Boots Aircraft Nut Corp.	Passadena, Calif.
		Culver City, Calif.	08727	National Radio Lab. Inc.	Paramus, N. J.	16688	Ideal Prec. Meter Co., Inc.	
04773	Automatic Electric Co.	Northlake, Ill.			Paramus, N. J.		De Jur Meter Div.	Brooklyn, N. Y.
04796	Sequoia Wire Co.	Redwood City, Calif.	08792	CBS Electronics-Semiconductor Operations, Div. of C. B. S. Inc.		16758	Delco Radio Div. of G. M. Corp.	Kokoma, Ind.
04811	Precision Coil Spring Co.	El Monte, Calif.			Lowell, Mass.	17109	Thermonetics Inc.	Canoga Park, Calif.
04870	P. M. Motor Company	Westchester, Ill.	08806	General Electric Co. Miniatur. Lamp Dept.		17474	Tranex Company	Mountain View, Calif.
04919	Component Mfg. Service Co.				Cleveland, Ohio	17554	Components Inc.	Biddeford, Ma.
		W. Bridgewater, Mass.	08984	Mel-Rain	Indianapolis, Ind.	17675	Hamlin Metal Products Corp.	Akron, Ohio
05006	Twentieth Century Plastics, Inc.	Los Angeles, Calif.	09026	Babcock Relays Div.	Costa Mesa, Calif.	17745	Angstrom Prec. Inc.	No. Hollywood, Calif.
		Los Angeles, Calif.	09134	Texas Capacitor Co.	Houston, Texas			

TABLE 6-3.

CODE LIST OF MANUFACTURERS (Continued)

Code No.	Manufacturer	Address	Code No.	Manufacturer	Address	Code No.	Manufacturer	Address
17870	McGraw-Edison Co.	Manchester, N. H.	62119	Universal Electric Co.	Owosso, Mich.	73899	JFD Electronics Corp.	Brooklyn, N. Y.
18042	Power Design Pacific Inc.	Palo Alto, Calif.	63743	Ward-Leonard Electric Co.	Mt. Vernon, N. Y.	73905	Jennings Radio Mfg. Corp.	San Jose, Calif.
18083	Clevite Corp., Semiconductor Div.	Palo Alto, Calif.	64959	Western Electric Co., Inc.	New York, N. Y.	73957	Groov-Pin Corp.	Ridgefield, N. J.
18324	Signetics Corp.	Sunnyvale, Calif.	65092	Weston Inst. Inc. Weston-Newark	Newark, N. J.	74276	Signalite Inc.	Neptune, N. J.
18476	Ty-Car Mfg. Co., Inc.	Holliston, Mass.	66295	Wittek Mfg. Co.	Chicago, Ill.	74455	J. H. Winns, and Sons	Winchester, Mass.
18486	TRW Elect. Comp. Div.	Des Plaines, Ill.	66346	Minnesota Mining & Mfg. Co.	Revere Mincom Div.	74861	Industrial Condenser Corp.	Chicago, Ill.
18583	Curtis Instrument, Inc.	Mt. Kisco, N. Y.	70276	Allen Mfg. Co.	Hartford, Conn.	74868	R. F. Products Division of Amphencol-Borg Electronics Corp.	Danbury, Conn.
18612	Vishay Instruments Inc.	Malvern, Pa.	70309	Allied Control	New York, N. Y.	74970	E. F. Johnson Co.	Waseca, Minn.
18873	E. I. DuPont and Co., Inc.	Wilmington, Del.	70318	Almetal Screw Product Co., Inc.	Garden City, N. Y.	75042	International Resistance Co.	Philadelphia, Pa.
18911	Durant Mfg. Co.	Milwaukee, Wis.	70417	Amplex, Div. of Chrysler Corp.	Detroit, Mich.	75263	Keystone Carbon Co., Inc.	St. Marys, Pa.
19315	The Bendix Corp., Navigation & Control Div.	Teterboro, N. J.	70485	Atlantic India Rubber Works, Inc.	Chicago, Ill.	75378	CTS Knights Inc.	Sandwich, Ill.
19500	Thomas A. Edison Industries, Div. of McGraw-Edison Co.	West Orange, N. J.	70563	Amperite Co., Inc.	Union City, N. J.	75382	Kulka Electric Corporation	Mt. Vernon, N. Y.
19589	LRC Electronics	Baldwin Park, Calif.	70674	ADC Products Inc.	Minneapolis, Minn.	75818	Lenz Electric Mfg. Co.	Chicago, Ill.
19644	Conco	West Orange, N. J.	70903	Belden Mfg. Co.	Chicago, Ill.	75915	Littlefuse, Inc.	Des Plaines, Ill.
19701	Electra Mfg. Co.	Independence, Kansas	70998	Bird Electronic Corp.	Cleveland, Ohio	76005	Lord Mfg. Co.	Erie, Pa.
20183	General Atomics Corp.	Philadelphia, Pa.	71002	Birnbach Radio Co.	New York, N. Y.	76210	C. W. Marwedel	San Francisco, Calif.
21226	Executone, Inc.	Long Island City, N. Y.	71034	Bliley Electric Co., Inc.	Erie, Pa.	76433	General Instrument Corp., Micamold Division	Newark, N. J.
21335	Fafnir Bearing Co., The	New Britain, Conn.	71041	Boston Gear Works Div. of Murray Co. of Texas	Quincy, Mass.	76487	James Millen Mfg. Co., Inc.	Malden, Mass.
21520	Fansteel Metallurgical Corp.	N. Chicago, Ill.	71218	Bud Radio, Inc.	Willoughby, Ohio	76493	J. W. Miller Co.	Los Angeles, Calif.
23042	Texscan Corp.	Indianapolis, Ind.	71279	Cambridge Thermionics Corp.	Cambridge, Mass.	76530	Cinch-Monadnock, Div. of United Carr Fastener Corp.	San Leandro, Calif.
23783	British Radio Electronics Ltd.	Washington, D. C.	71286	Camloc Fastener Corp.	Paramus, N. J.	76545	Mueller Electric Co.	Cleveland, Ohio
24455	G. E. Lamp Division	Nela Park, Cleveland, Ohio	71313	Cardwell Condenser Corp.	Lindenhurst L. I., N. Y.	76703	National Union	Newark, N. J.
24655	General Radio Co.	West Concord, Mass.	71400	Bussmann Mfg. Div. of McGraw-Edison Co.	St. Louis, Mo.	76854	Oak Manufacturing Co.	Crystal Lake, Ill.
24681	Memcor Inc., Comp. Div.	Huntington, Ind.	71436	Chicago Condenser Corp.	Chicago, Ill.	77068	The Bendix Corp., Electrodynamics Div.	N. Hollywood, Calif.
24796	Pareco Inc.	San Juan Capistrano, Calif.	71447	Calif. Spring Co., Inc.	Pico-Rivera, Calif.	77075	Pacific Metals Co.	San Francisco, Calif.
26365	Gries Reproducer Corp.	New Rochelle, N. Y.	71450	CTS Corp.	Elkhart, Ind.	77221	Phanotron Instrument and Electronic Co.	South Pasadena, Calif.
26462	Grobel File Co. of America, Inc.	Carlstadt, N. J.	71468	ITT Cannon Electric Inc.	Los Angeles, Calif.	77252	Philadelphia Steel and Wire Corp.	Philadelphia, Pa.
26851	Compac/Hollister Co.	Hollister, Calif.	71471	Cinema, Div. Aerovox Corp.	Burbank, Calif.	77342	American Machine & Foundry Co. Potter & Brunfield Div.	Princeton, Ind.
26992	Hamilton Watch Co.	Lancaster, Pa.	71482	C. P. Clare & Co.	Chicago, Ill.	77630	TRW Electronic Components Div.	Camden, N. J.
27251	Specialities Mfg. Co., Inc.	Stratford, Conn.	71590	CentriTab Div. of Globe Union Inc.	Milwaukee, Wis.	77638	General Instrument Corp., Rectifier Div.	Brooklyn, N. Y.
28480	Hewlett-Packard Co.	Palo Alto, Calif.	71616	Commercial Plastics Co.	Chicago, Ill.	77764	Resistance Products Co.	Harrisburg, Pa.
28520	Heyman Mfg. Co.	Kenilworth, N. J.	71700	Cornish Wire Co., The	New York, N. Y.	77969	Rubbercraft Corp. of Calif.	Torrance, Calif.
30817	Instrument Specialties Co., Inc.	Little Falls, N. J.	71707	Coto Coil Co., Inc.	Providence, R. I.	78189	Shakeproof Division of Illinois Tool Works	Elgin, Ill.
31373	G. E. Receiving Tube Dept.	Owensboro, Ky.	71744	Chicago Miniature Lamp Works	Chicago, Ill.	78277	Sigma	So. Braintree, Mass.
35434	Lectrohm Inc.	Chicago, Ill.	71785	Cinch Mfg. Co., Howard B. Jones Div.	Chicago, Ill.	78283	Signal Indicator Corp.	New York, N. Y.
36196	Stanwyck Coil Products Ltd.	Hawkesbury, Ontario, Canada	71984	Dow Corning Corp.	Midland, Mich.	78290	Struthers-Dunn Inc.	Pitman, N. J.
36287	Cunningham, W. H. & Hill, Ltd.	Toronto Ontario, Canada	72136	Electro Motive Mfg. Co., Inc.	Williamantic, Conn.	78424	Speciality Leather Prod. Co.	Newark, N. J.
37942	P. R. Mallory & Co. Inc.	Indianapolis, Ind.	72619	Dialight Corp.	Brooklyn, N. Y.	78452	Thompson-Bremer & Co.	Chicago, Ill.
39543	Mechanical Industries Prod. Co.	Akron, Ohio	72656	Indiana General Corp., Electronics Div.	Keasby, N. J.	78471	Tilley Mfg. Co.	San Francisco, Calif.
40920	Miniature Precision Bearings, Inc.	Keene, N. H.	72699	General Instrument Corp., Cap. Div.	Newark, N. J.	78488	Stackpole Carbon Co.	St. Marys, Pa.
42190	Muter Co.	Chicago, Ill.	72765	Drake Mfg. Co.	Harwood Heights, Ill.	78493	Standard Thomson Corp.	Waltham, Mass.
43990	C. A. Norgren Co.	Englewood, Colo.	72825	Hugh H. Eby Inc.	Philadelphia, Pa.	78553	Tinnerman Products, Inc.	Cleveland, Ohio
44655	Ohmite Mfg. Co.	Skokie, Ill.	72928	Gudeman Co.	Chicago, Ill.	78790	Transformer Engineers	San Gabriel, Calif.
46384	Penn Eng. & Mfg. Corp.	Doylestown, Pa.	72962	Elastic Stop Nut Corp.	Union, N. J.	78947	Ucinite Co.	Newtownville, Mass.
47904	Polaroid Corp.	Cambridge, Mass.	72964	Robert M. Hadley Co.	Los Angeles, Calif.	79136	Waldes Kohinor Inc.	Long Island City, N. Y.
48620	Precision Thermometer & Inst. Co.	Southampton, Pa.	72982	Erie Technological Products, Inc.	Erie, Pa.	79142	Veeder Root, Inc.	Hartford, Conn.
49956	Microwave & Power Tube Div.	Waltham, Mass.	73061	Hansen Mfg. Co., Inc.	Princeton, Ind.	79251	Wenco Mfg. Co.	Chicago, Ill.
52090	Rowan Controller Co.	Westminster, Md.	73076	H. M. Harper Co.	Chicago, Ill.	79727	Continental-Wirt Electronics Corp.	Philadelphia, Pa.
52983	Sanborn Company	Waltham, Mass.	73138	Helipot Div. of Beckman Inst., Inc.	Fallerton, Calif.	79963	Zierick Mfg. Corp.	New Rochelle, N. Y.
54294	Shallcross Mfg. Co.	Selma, N. C.	73293	Hughes Products Division of Hughes Aircraft Co.	Newport Beach, Calif.	80031	Mepec Division of Sessions Clock Co.	Morristown, N. J.
55026	Simpson Electric Co.	Chicago, Ill.	73445	Amperex Elect. Co.	Hicksville, L. I., N. Y.	80120	Schnitzer Alloy Products Co.	Elizabeth, N. J.
55933	Sonotone Corp.	Elmsford, N. Y.	73506	Bradley Semiconductor Corp.	New Haven, Conn.	80131	Electronic Industries Association. Tube meeting EIA Standards-Washington, DC.	Any brand
55938	Raytheon Co. Commercial Apparatus & Systems Div.	So. Norwalk, Conn.	73559	Carlting Electric, Inc.	Hartford, Conn.	80207	Unimax Switch, Div. Maxon Electronics Corp.	Wallingford, Conn.
56137	Spaulding Fibre Co., Inc.	Tonawanda, N. Y.	73586	Circle F Mfg. Co.	Trenton, N. J.	80223	United Transformer Corp.	Chicago, Ill.
56289	Sprague Electric Co.	North Adams, Mass.	73682	George K. Garrett Co., Div. MSL Industries Inc.	Philadelphia, Pa.	80248	Oxford Electric Corp.	Chicago, Ill.
59446	Telex Corp.	Tulsa, Okla.	73734	Federal Screw Products Inc.	Chicago, Ill.	80294	Bourns Inc.	Riverside, Calif.
59730	Thomas & Betts Co.	Elizabeth, N. J.	73743	Fischer Special Mfg. Co.	Cincinnati, Ohio	80411	Acro Div. of Robertshaw Controls Co.	Columbus, Ohio
60741	Triplett Electrical Inst. Co.	Bluffton, Ohio	73793	General Industries Co., The	Elyria, Ohio			
61775	Union Switch and Signal, Div. of Westinghouse Air Brake Co.	Pittsburgh, Pa.	73846	Goshen Stamping & Tool Co.	Goshen, Ind.			

TABLE 6-3.
CODE LIST OF MANUFACTURERS (Continued)

Code No.	Manufacturer	Address	Code No.	Manufacturer	Address	Code No.	Manufacturer	Address
80486	All Star Products Inc.	Defiance, Ohio	86684	Radio Corp. of America, Electronic		95566	Arnold Engineering Co.	Marengo, Ill.
80509	Avery Label Co.	Monrovia, Calif.		Comp. & Devices Div.	Harrison, N. J.	95712	Dage Electric Co., Inc.	Franklin, Ind.
80583	Hammarlund Co., Inc.	Mars Hill, N. C.	86928	Seastrom Mfg. Co.	Glendale, Calif.	95984	Simon Mfg. Co.	Wayne, Ill.
80640	Stevens, Arnold, Co., Inc.	Boston, Mass.	87034	Marco Industries	Anaheim, Calif.	95987	Weckesser Co.	Chicago, Ill.
80813	Dimco Gray Co.	Dayton, Ohio	87216	Philco Corporation (Lansdale Division)	Lansdale, Pa.	96067	Microwave Assoc., West Inc.	Sunnyvale, Calif.
81030	International Instruments Inc.	Orange, Conn.				96095	Hi-Q Div. of Aerovox Corp.	Olean, N. Y.
81073	Grayhill Co.	LaGrange, Ill.	87473	Western Fibrous Glass Products Co.	San Francisco, Calif.	96256	Thordarson-Meissner Inc.	Mt. Carmel, Ill.
81095	Triad Transformer Corp.	Venice, Calif.				96296	Solar Manufacturing Co.	Los Angeles, Calif.
81312	Winchester Elec. Div. Litton Ind., Inc.	Oakville, Conn.	87664	Van Waters & Rogers Inc.	San Francisco, Calif.	96306	Microswitch, Div. of Minn.-Honeywell	Freeport, Ill.
81349	Military Specification		87930	Tower Mfg. Corp.	Providence, R. I.	96330	Carlton Screw Co.	San Fernando, Calif.
81483	International Rectifier Corp.	El Segundo, Calif.	88140	Cutler-Hammer, Inc.	Lincoln, Ill.	96341	Microwave Associates, Inc.	Burlington, Mass.
81541	Airpax Electronics, Inc.	Cambridge, Maryland	88220	Gould-National Batteries, Inc.	St. Paul, Minn.	96501	Excel Transformer Co.	Oakland, Calif.
81860	Barry Controls, Div. Barry Wright Corp.	Watertown, Mass.	88698	General Mills, Inc.	Buffalo, N. Y.	96733	San Fernando Elect. Mfg. Co.	San Fernando, Calif.
			89231	Graybar Electric Co.	Oakland, Calif.			
82042	Carter Precision Electric Co.	Skokie, Ill.	89473	G. E. Distributing Corp.	Schenectady, N. Y.	96881	Thomson Ind. Inc.	Long Is., N. Y.
82047	Sperit Faraday Inc., Copper Hewitt Electric Div.	Hoboken, N. J.	89665	United Transformer Co.	Chicago, Ill.	97464	Industrial Retaining Ring Co.	Irvington, N. J.
82116	Electric Regulator Corp.	Norwalk, Conn.	90030	United Shoe Machinery Corp.	Beverly, Mass.	97539	Automatic & Precision Mfg.	Englewood, N. J.
82142	Jeffers Electronics Division of Speer Carbon Co.	Du Bois, Pa.	90179	US Rubber Co., Consumer Ind. & Plastics Prod. Div.	Passaic, N. J.	97979	Reon Resistor Corp.	Yonkers, N. Y.
82170	Fairchild Camera & Inst. Corp. Space & Defense System Div.	Paramus, N. J.	90970	Bearing Engineering Co.	San Francisco, Calif.	97983	Litton System Inc., Adier-Westrex Commun. Div.	New Rochelle, N. Y.
82209	Maguire Industries, Inc.	Greenwich, Conn.	91146	ITT Cannon Elect, Inc., Salem Div.	Salem, Mass.	98141	R-Tronics, Inc.	Jamaica, N. Y.
82219	Sylvania Electric Prod. Inc. Electronic Tube Division	Emporium, Pa.	91260	Connor Spring Mfg. Co.	San Francisco, Calif.	98159	Rubber Teck, Inc.	Gardena, Calif.
82376	Astron Corp.	East Newark, Harrison, N. J.	91345	Miller Dial & Nameplate Co.	El Monte, Calif.	98220	Hewlett-Packard Co., Moseley Div.	Pasadena, Calif.
82389	Switchcraft, Inc.	Chicago, Ill.	91418	Radio Materials Co.	Chicago, Ill.	98278	Microdot, Inc.	So. Pasadena, Calif.
82647	Metals & Controls Inc. Spencer Products	Attleboro, Mass.	91506	Augat Inc.	Attleboro, Mass.	98291	Seaflecto Corp.	Mamaroneck, N. Y.
			91637	Dale Electronics, Inc.	Columbus, Nebr.	98376	Zero Mfg. Co.	Burbank, Calif.
82768	Phillips-Advance Control Co.	Joliet, Ill.	91662	Elco Corp.	Willow Grove, Pa.	98410	Etc Inc.	Cleveland, Ohio
82866	Research Products Corp.	Madison, Wis.	91737	Gremar Mfg. Co., Inc.	Wakefield, Mass.	98731	General Mills Inc., Electronics Div.	Minneapolis, Minn.
82877	Rotron Mfg. Co., Inc.	Woodstock, N. Y.	91827	K F Development Co.	Redwood City, Calif.			
82893	Vector Electronic Co.	Glendale, Calif.	91886	Malco Mfg. Co., Inc.	Chicago, Ill.	98734	Paeco Div. of Hewlett-Packard Co.	Palo Alto, Calif.
83014	Hartwell Corp.	Los Angeles, Calif.	91929	Honeywell Inc., Micro Switch Div.	Freeport, Ill.			
83058	Carr Fastener Co.	Cambridge, Mass.	91961	Nahm-Bros. Spring Co.	Oakland, Calif.	98821	North Hills Electronics, Inc.	Glen Cove, N. Y.
83086	New Hampshire Ball Bearing, Inc.	Peterborough, N. H.	92180	Tru-Connector Corp.	Peabody, Mass.	98978	International Electronic Research Corp.	Burbank, Calif.
			92367	Elgeet Optical Co. Inc.	Rochester, N. Y.	99109	Columbia Technical Corp.	New York, N. Y.
83125	General Instrument Corp., Capacitor Div.	Darlington, S. C.	92607	Tensolite Insulated Wire Co., Inc.	Tarrytown, N. Y.	99313	Varian Associates	Palo Alto, Calif.
						99378	Allee Corp.	Winchester, Mass.
83148	ITT Wire and Cable Div.	Los Angeles, Calif.	92702	IMC Magnetics Corp.	Wesbury Long Island, N. Y.	99515	Marshall Ind., Capacitor Div.	Monrovia, Calif.
83186	Victory Eng. Corp.	Springfield, N. J.	92966	Hudson Lamp Co.	Kearney, N. J.	99707	Control Switch Division, Controls Co. of America	El Segundo, Calif.
83298	Bendix Corp., Red Bank Div.	Red Bank, N. J.	93332	Sylvania Electric Prod. Inc. Semiconductor Div.	Woburn, Mass.	99800	Delevan Electronics Corp.	East Aurora, N. Y.
83315	Hubbell Corp.	Mundelein, Ill.	93369	Robbins & Myers Inc.	Palisades Park, N. J.	99848	Wilco Corporation	Indianapolis, Ind.
83324	Rosan Inc.	Newport Beach, Calif.	93410	Stemco Controls, Div. of Essex Wire Corp.	Mansfield, Ohio	99928	Branson Corp.	Whippany, N. J.
83330	Smith, Herman H., Inc.	Brooklyn, N. Y.	93632	Waters Mfg. Co.	Culver City, Calif.	99934	Renbrandt, Inc.	Boston, Mass.
83332	Tech Labs	Palisades Park, N. J.	93929	G. V. Controls	Livingston, N. J.	99942	Hoffman Electronics Corp. Semiconductor Div.	El Monte, Calif.
83385	Central Screw Co.	Chicago, Ill.	94137	General Cable Corp.	Bayonne, N. J.	99957	Technology Instrument Corp. of Calif.	Newbury Park, Calif.
83501	Gavitt Wire and Cable Co. Div. of Amerace Corp.	Brookfield, Mass.	94142	Phelps Dodge	Yonkers, N. Y.			
83594	Burroughs Corp. Electronic Tube Div.	Plainfield, N. J.	94144	Raytheon Co., Comp. Div., Ind. Comp. Operations	Quincy, Mass.			
83740	Union Carbide Corp. Consumer Prod. Div.	Plainfield, N. J.	94148	Scientific Electronics Products, Inc.	Loveland, Colo.			
			94154	Wagner Elect. Corp., Tung-Sol Div.	Newark, N. J.			
83777	Model Eng. and Mfg., Inc.	Huntington, Ind.	94197	Curtiss-Wright Corp. Electronics Div.	Newark, N. J.			
83821	Loyd Scruggs Co.	Festus, Mo.						
83942	Aeronautical Inst. & Radio Co.	Lodi, N. J.	94222	South Chester Corp.	Chester, Pa.			
84171	Arco Electronics Inc.	Great Neck, N. Y.	94330	Wire Cloth Products, Inc.	Bellwood, Ill.			
84396	A. J. Glesener Co., Inc.	San Francisco, Calif.	94375	Automatic Metal Products Co.	Brooklyn, N. Y.			
84411	TRW Capacitor Div.	Ogallala, Neb.	94682	Worcester Pressed Aluminum Corp.	Worcester, Mass.			
84970	Sarkes Tazjian, Inc.	Bloomington, Ind.						
85454	Boonton Molding Company	Boonton, N. J.	94696	Magnecraft Electric Co.	Chicago, Ill.			
85471	A. B. Boyd Co.	San Francisco, Calif.	95023	George A. Philbrick Researchers, Inc.	Boston, Mass.			
85474	R. M. Bracamonte & Co.	San Francisco, Calif.						
85660	Koiled Kords, Inc.	Hamden, Conn.	95236	Allies Products Corp.,	Dania, Fla.			
85911	Seamless Rubber Co.	Chicago, Ill.	95238	Continental Connector Corp.	Woodside, N. Y.			
86174	Fafnir Bearing Co.	Los Angeles, Calif.	95263	Leecraft Mfg. Co., Inc.	Long Island, N. Y.			
86197	Clifton Precision Products Co., Inc.	Clifton Heights, Pa.	95265	National Coil Co.	Sheridan, Wyo.			
			95275	Vitramon, Inc.	Bridgeport, Conn.			
86579	Precision Rubber Products Corp.	Dayton, Ohio	95348	Gordos Corp.	Bloomfield, N. J.			
			95354	Methode Mfg. Co.	Rolling Meadows, Ill.			

THE FOLLOWING HP VENDORS HAVE NO NUMBER ASSIGNED IN THE LATEST SUPPLEMENT TO THE FEDERAL SUPPLY CODE FOR MANUFACTURERS HANDBOOK.

0000F	Malco Tool and Die	Los Angeles, Calif.
0000Z	Willow Leather Products Corp.	Newark, N. J.
000AB	ETA	England
000BB	Precision Instrument Components Co.	Van Nuys, Calif.
000CS	Hewlett-Packard Co., Colorado Springs	Colorado Springs, Colorado
000MM	Rubber Eng. & Development	Hayward, Calif.
000NN	A "N" D Mfg. Co.	San Jose, Calif.
000QQ	Cooltron	Oakland, Calif.
000WW	California Eastern Lab.	Burlington, Calif.
000YY	S. K. Smith Co.	Los Angeles, Calif.

SECTION VII SCHEMATIC DIAGRAMS

7-1. INTRODUCTION.

7-2. This section contains schematic and component locations diagrams. Figure 7-2 lists notes and symbols which apply to all schematic diagrams. For clarity, some of the symbols used are also explained here. Figure 7-4 is a functional block diagram which includes the schematic location of circuit sections by page number. Each schematic diagram has been presented following the general guide lines listed below.

a. Schematics in this manual show electrical circuit operation and are not intended as wiring diagrams. Switch and circuit board assemblies often appear in part on several different schematics. To find a specific instrument component or circuit section, refer to Figure 7-4 or the "REFERENCE DESIGNATION" box on each schematic where the reference designators are listed for all components.

b. Special notes that only refer to one circuit section of the instrument are given on the schematic of the circuit section only.

c. Circuit assemblies are outlined and shown as shaded areas. The component reference designations within these shaded assemblies are abbreviated. Full component designation includes assembly number (see Schematic Information illustration shown below).

7-3. REPLACEMENT INFORMATION

7-4. For repair and replacement information, refer to the REPAIR AND REPLACEMENT information which is included in Section V. For specific component descriptions and/or ordering information refer to page 6-1.

NOTE

See inside rear cover
for overall schematic.

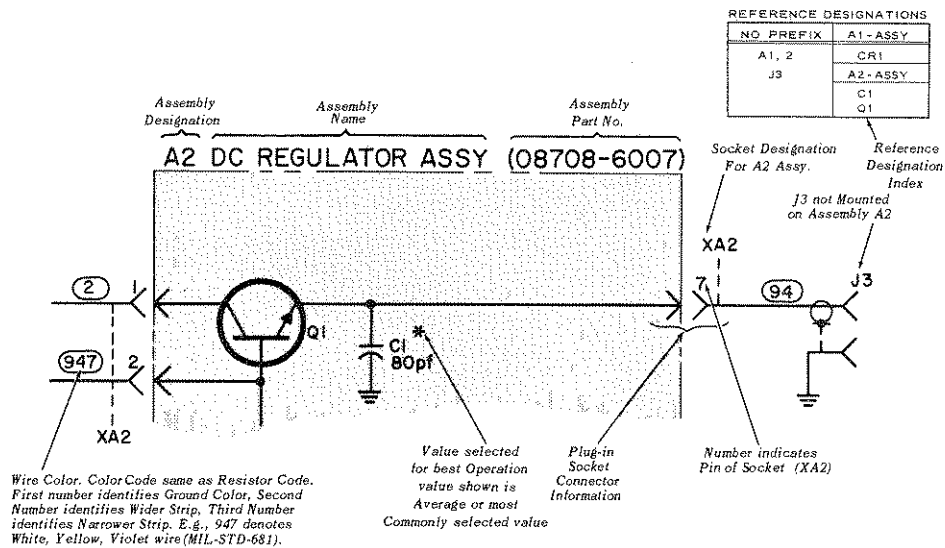

Figure 7-1. Explanations of General Information on Schematic Diagrams

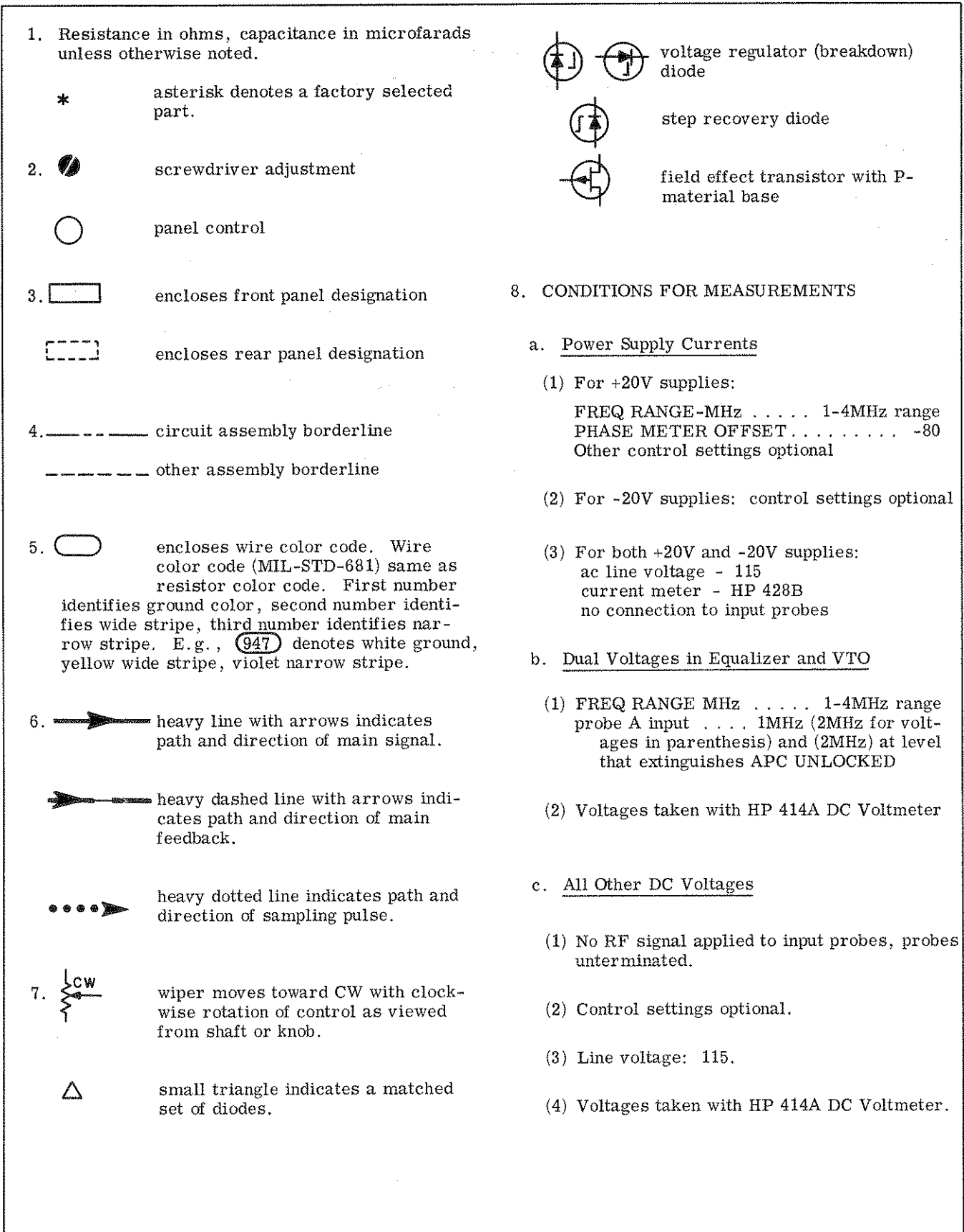

Figure 7-2. Schematic Diagram Notes

APPENDIX I

MANUAL CHANGES

MODEL 8405A
VECTOR VOLTMETER

Manual Serial Prefixed: 946-
HP Part No. 08405-90022

To adapt this manual to instruments with Serial Numbers listed in the table below, make the indicated manual changes.

Information for adapting this manual to instruments with Serial Numbers not listed in the table below may be included in a yellow MANUAL CHANGES insert supplied with this manual. Information about serial numbers not covered in any of these ways can be obtained from your nearest Hewlett-Packard office.

Instrument Serial Prefix	Make Manual Changes	Instrument Serial Prefix	Make Manual Changes
946-03210 thru 946-02911	1	805-	1, 2, 3, 4, 5, 6, 7, 8, 9, 10, 11
942-02910 thru 942-02861	1, 2	742-, 741-, 732-	1, 2, 3, 4, 5, 6, 7, 8, 9, 10, 11, 12
942-02860 thru 942-02811	1, 2, 3	725-, 724-, 717-	1, 2, 3, 4, 5, 6, 7, 8, 9, 10, 11, 12, 13
942-02810 thru 942-02780 838-02779 thru 838-02711	1, 2, 3, 4	645-	1, 2, 3, 4, 5, 6, 7, 8, 9, 10, 11, 12, 13, 14
838-02710 thru 838-02211	1, 2, 3, 4, 5	631-	1, 2, 3, 4, 5, 6, 7, 8, 9, 10, 11, 12, 13, 14 15
838-02210 thru 838-02161	1, 2, 3, 4, 5, 6	626-	1, 2, 3, 4, 5, 6, 7, 8, 9, 10, 11, 12, 13, 14 15, 16
838-02160 thru 838-02111	1, 2, 3, 4, 5, 6, 7	611- and below	1, 2, 3, 4, 5, 6, 7, 8, 9, 10, 11, 12, 13, 14 15, 16, 17
838-02110 thru 838-02061	1, 2, 3, 4, 5, 6, 7, 8		
824-	1, 2, 3, 4, 5, 6, 7, 8, 9		
813-	1, 2, 3, 4, 5, 6, 7, 8, 9, 10		

CHANGE 1: Page 6-25:
Change DS2 to 1450-0138, LIGHT, INDICATOR, RED

CHANGE 2: Page 6-25:
Change P1 to Part No. 1251-0148
Change S1 to Part No. 3101-0100
Change S2 to Part No. 3101-0033

Page 6-26:
Change W11 to Part No. 8120-0078

Page 6-27:
Change Item 2 to Part No. 08405-0001
Change Item 13 to Part No. 08405-0002

Page 7-19/7-20
Change S1 pin numbers from 3 to 1, from 6 to 2, from 1 to 4, and from 4 to 5.

CHANGE 3:

Page 6-2:

Change A3R5 to HP Part No. 2100-0783, R: VAR WW 200 OHM 5% 1W.

Page 6-3:

Change A3R27 to HP Part No. 0757-0401, R: FXD MET FLM 100 OHM 1% 1/8W
FACTORY SELECTED PART.

Change A4R5 to HP Part No. 2100-0783, R: VAR WW 200 OHM 5% 1W.

Page 6-4:

Change A4R27 to HP Part No. 0757-0401, R: FXD MET FLM 100 OHM 1% 1/8W,
FACTORY SELECTED PART

CHANGE 4:

Page 6-8:

Delete A8CR4, A8CR5, A8L1, and A8L2.

Page 6-9:

Change Part No. of Heat Dissipator under A8Q14, A8Q15, A8Q18 and A8Q19 to
1205-0041.

Page 6-10:

Delete A8R38.

Page 7-11/7-12:

Delete A8CR4, A8CR5, A8L1, A8L2 and A8R38.

CHANGE 5:

Page 6-3:

Change A3R19 to HP Part No. 0698-3153, R: FXD MET FLM, 3.83K OHM 1% 1/8W.
Change A4R19 to HP Part No. 0698-3153, R: FXD MET FLM, 3.83K OHM 1% 1/8W.

Page 7-5/7-6:

Change A3R19 and A4R19 to 3.83K OHM.

CHANGE 6:

To reduce Residual Noise level caused by power supply, it is recommended that resistors
A16R8 and A16R20 be changed.

From: 0698-3150 R: FXD MET FLM, 2.37K OHM 1% 1/8W.
To: 0757-0077 R: FXD MET FLM 1.2K OHM 2% 1/4W.

CHANGE 7:

To reduce the amplitude error of the voltmeter above 800 MHz and on the 0 dB range, it
is recommended that resistors A3R21, A3R25, A4R21 and A4R26 be changed.

From: 0757-0316 R: FXD MET FLM 42.2 OHM 1% 1/8W.
To: 0757-0294 R: FXD MET FLM 17.8 OHM 1% 1/8W.

CHANGE 8:

This change applies ONLY to the A8 Phase Meter Assy with HP Part Number 08405-6058.
To eliminate spurious or erratic phase meter indications, it is recommended that induc-
tors A8L1 and A8L2 be removed.

Delete: A8L1, L2 9140-0120 COIL: FXD 0.10 μ H 20%.

CHANGE 9: A8 Phase Meter Assy is different (see Figure 1 below) than shown in Figure 7-11.

Table 6-1, Pages 6-8, 6-9 and 6-10,

Add: A8CR4, 6; 1901-0040; DIODE SILICON 30 MA 30 MV
 A8CR5, 7; 1902-3106; DIODE BREAKDOWN 5.76 V
 A8R28, R35; 0757-0279; R:FXD 3.16K ohm 1% 1/8 W

Change: A8 Phase meter assembly part number to 08405-6008.

Change Resistors A8R26, R33,

To: 2100-1657 R:VAR WW 1K OHM 10% 1 W
 From: 0757-0405 R:FXD MET FLM 162 OHM 1% 1/8 W

Change Resistors A8R27, R34,

To: 0698-0084 R:FXD MET FLM 2.15K OHM 1% 1/8 W
 From: 0698-3101 R:FXD MET FLM 2.87K OHM 1% 1/2 W

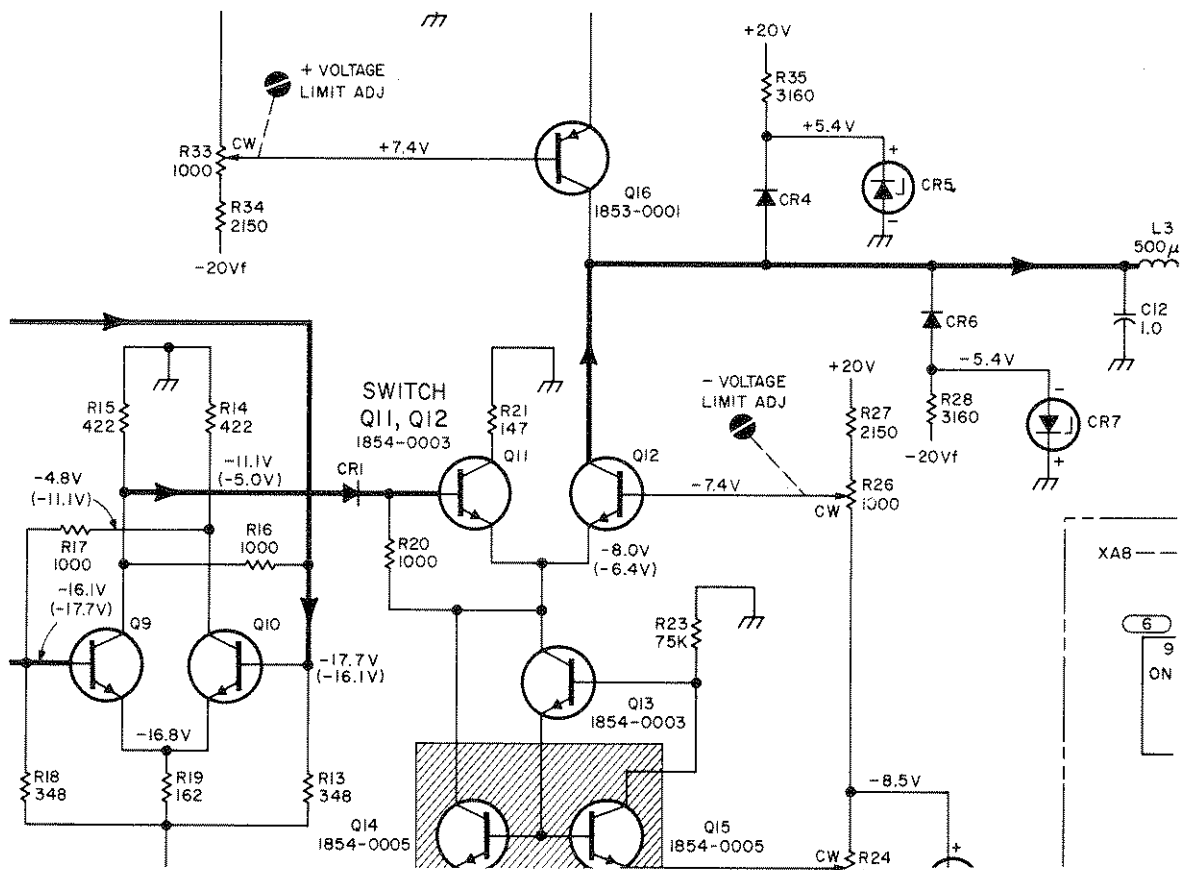

Figure 1. Partial Schematic of A8 Phase Meter Assy (08405-6008)

CHANGE 9: (Cont.)

Table 6-2, pages 6-29 thru 6-32,

HP Part Number 0698-3101 change TQ to 0.
 HP Part Number 0698-0084 change TQ to 17.
 HP Part Number 0757-0279 change TQ to 8.
 HP Part Number 0757-0405 change TQ to 3.
 HP Part Number 1901-0040 change TQ to 36.

Add the following:

HP Part Number 1902-3106; Diode breakdown 5.76 volts; 28480; TQ 2.
 HP Part Number 2100-1657; R:VAR WW 1000 ohm 10% 1 W; 28480; TQ 2.

CHANGE 10: a.) A11 Sampler Assy 08405-6011 is different (see Figure 2) than shown in Figure 7-15.

Table 6-1, Pages 6-13 thru 6-15,

Add: A11C9	0150-0050	C:FXD CER 1000 PF 600VDCW
A11C10	0140-0176	C:FXD MICA 100 PF 2%
A11C14	0140-0176	C:FXD MICA 100 PF 2%
A11C15	0150-0050	C:FXD CER 1000 PF 600VDCW
A11C18	0180-0116	C:FXD ELECT 6.8 UF 10% 35VDCW
A11R14	0757-0346	R:FXD MET FLM 10 OHM 1% 1/8W
A11R16	0698-3157	R:FXD MET FLM 19.6K OHM 1% 1/8W
A11R17	0757-0440	R:FXD MET FLM 7.5K OHM 1% 1/8W
A11R27	0757-0440	R:FXD MET FLM 7.5K OHM 1% 1/8W
A11R29	0698-3157	R:FXD MET FLM 19.6K OHM 1% 1/8W
A11R30	0757-0394	R:FXD MET FLM 51.1 OHM 1% 1/8W
A11R32	0757-0346	R:FXD MET FLM 10 OHM 1% 1/8W
A11R33	0698-3440	R:FXD MET FLM 196 OHM 1% 1/8W

Change:

A11CR17 and A11CR6; 1903-0006; Diode 4 layer silicon
 A11Q2; 1854-0087; Transistor; NPN Silicon 2N3417
 A11Q3; 1854-0071; Transistor; NPN Silicon
 A11Q6; 1854-0071; Transistor; NPN Silicon
 A11R8 & R9; 0757-0417; R:FXD 562 OHM 1% 1/8W
 A11R15 & R28; 0757-0279; R:FXD 3.16K OHM 1% 1/8W

Delete: A11Q7

Table 6-2, Pages 6-28 thru 6-32,

HP Part Number 0140-0176 change TQ to 8
 HP Part Number 0150-0050 change TQ to 3
 HP Part Number 0180-0116 change TQ to 7
 HP Part Number 0698-0084 change TQ to 15
 HP Part Number 0698-3157 change TQ to 16
 HP Part Number 0698-3440 change TQ to 15
 HP Part Number 0757-0394 change TQ to 10
 HP Part Number 0757-0440 change TQ to 6
 HP Part Number 0757-0346 change TQ to 4
 HP Part Number 0757-0279 change TQ to 10
 HP Part Number 0757-0815 change TQ to 0
 HP Part Number 1853-0010 change TQ to 1
 HP Part Number 1854-0039 change TQ to 0
 HP Part Number 1854-0071 change TQ to 49
 HP Part Number 1901-0040 change TQ to 34

Add the following:

0757-0417; R:FXD 562 OHM 1% 1/8W; TQ 2
 1854-0087; Transistor NPN Silicon 2N3417; TQ1
 1903-0006; Diode 4 Layer Silicon; TQ 2

b.) In the event of A12R27 failure, it is recommended that the value be changed.

From: 0698-3446 R:FXD 383OHM 1% 1/8W
 To: 0686-4315 R:FXD 430Ω 5% 1/2W

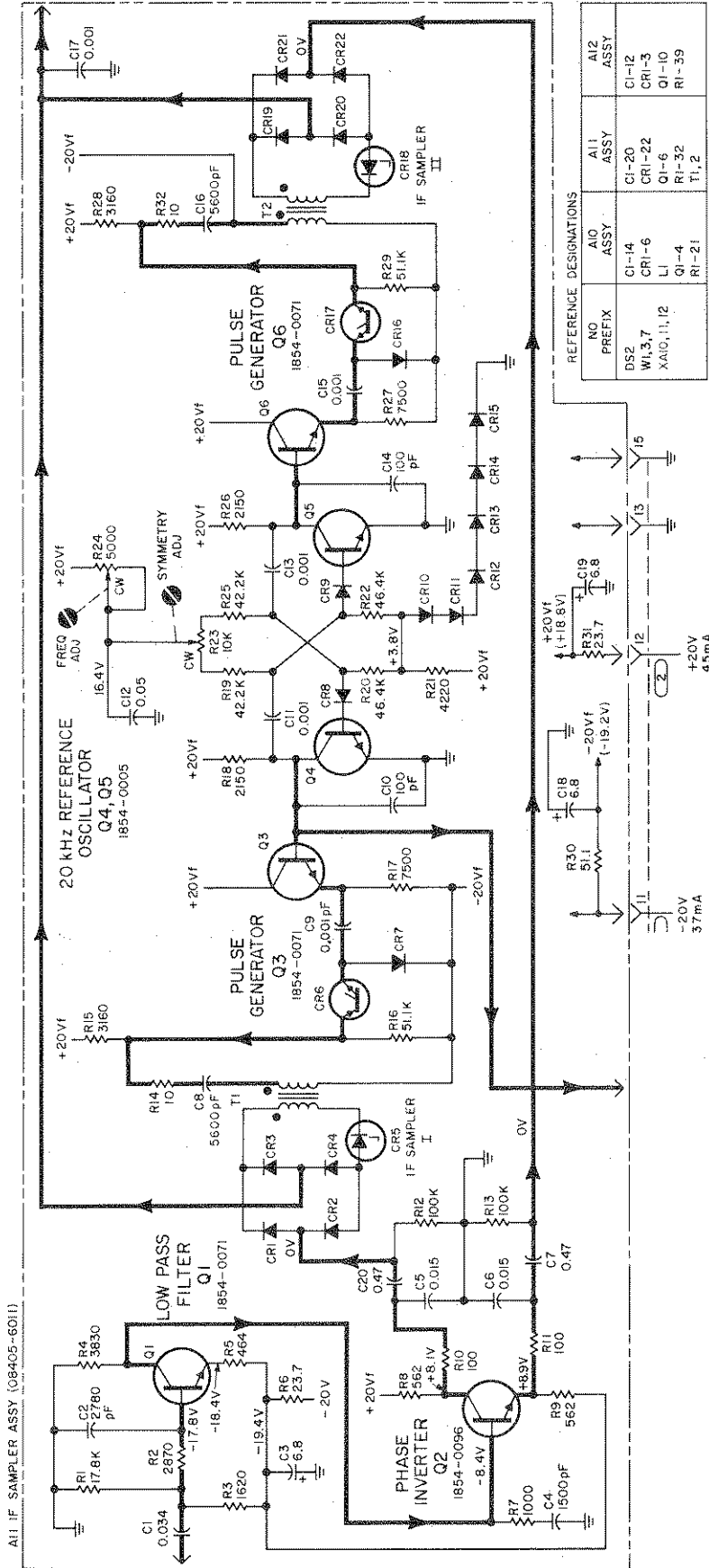

Figure 2. Schematic of A11 IF Sampler Assy (08405-6011)

CHANGE 11: To improve reliability of the A13 EQUALIZER Assy (08405-6013) it is recommended that capacitors A13C3 and A13C4 be changed.

From: 0170-0069 C:FXD Poly 0.1 μ f 2% 50 VDCW
 To: 0160-0168 C:FXD MY 0.1 μ f 10% 200 VDCW

CHANGE 12: a.) To improve circuit performance of the A15 Pulse Generator Assy (08405-6015) it is recommended that Resistors A15R1 and A15R2 be changed.

From: 0757-0346 R:FXD MET FLM 10 OHM 1% 1/8W
 To: 0757-0396 R:FXD MET FLM 51.1 OHM 1% 1/8W

b.) To improve circuit performance of the A11 Sampler Assy (08405-6011), it is recommended that Resistors A11R16 and A11R29 be changed.

From: 0698-3157 R:FXD MET FLM 19.6K OHM 1% 1/8W
 To: 0757-0458 R:FXD MET FLM 51.1K OHM 1% 1/8W

CHANGE 13: a.) An improved probe Assy 08405-6054 (item "C" of Figure 3 of this Appendix) was designed for use with all 8405A Vector Voltmeters, regardless of prefix serial number.

NOTE

Type "A" probes (08405-6001) or type "B" probes (08405-6046) are no longer available. In the event of a type "A" or type "B" probe failure, both probe assemblies CHANNEL A and CHANNEL B will have to be replaced. Replacement Kit 08405-6056 supplies (2) complete type "C" probe assemblies and Service Note (P-08405-6056) supplies the necessary replacement and adjustment procedures. Replacement Kits or Service Notes are available through the nearest HP Office.

b.) If the APC Light (DS2) fails, it is recommended that diode A12CR2 be changed (see Parts List for description).

CHANGE 14: For increased accuracy of the voltmeter, it is recommended that resistors A5R31 and A18R31 be removed and replaced with inductors A5L2 and A18L2 (see Parts List for description).

CHANGE 15: a.) To eliminate possible oscillations of A6Q4, the recommended replacement is (HP Part Number 1854-0371).

b.) To improve range to range tracking of the VOLTMETER, add capacitor A22C1 to A22 Amplitude Range Switch Assy (see Figures 7-12 and 7-13).

CHANGE 16: a.) To suppress oscillations which may occur on A10 APC Amplifier Assy (08405-6010), it is recommended that A10R5 be changed.

From: 0757-0394 R:FXD MET FLM 51.1 OHM 1% 1/8W
 To: 0757-0406 R:FXD MET FLM 182 OHM 1% 1/8W

b.) To dampen oscillations on the A6 180° Switch Assy (08405-6006), it is recommended that a ferrite bead A6L2 be added in the base lead of A6Q4.

Add: A6L2 9170-0016 Ferrite Bead

CHANGE 17: To improve performance of the A14 VTO Assy (08405-6014), it is recommended that resistors A14R23 and R4 be added. R4 is to be inserted between pin 9 of XA14 and wiper A of A24 Frequency Range Switch Assy (see Figures 7-16 and 7-17).

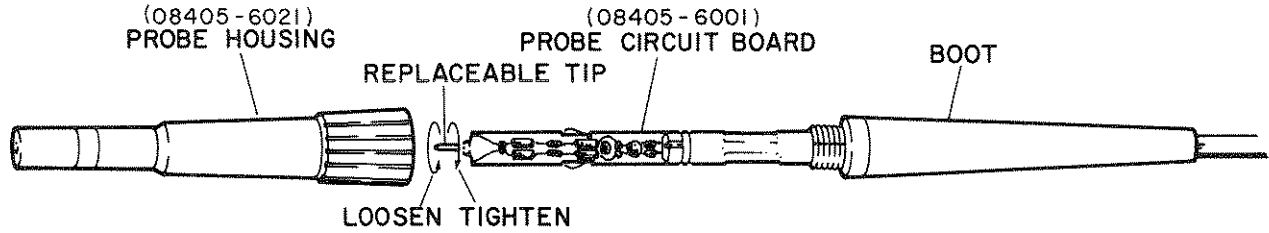

"A" Type Probe: The Original Probe

Shipment Dates: May 1966 through December 1966
 Serial Numbers: 611-00101 through 645-00660
 Identifying Feature: Probe tip screws into probe board

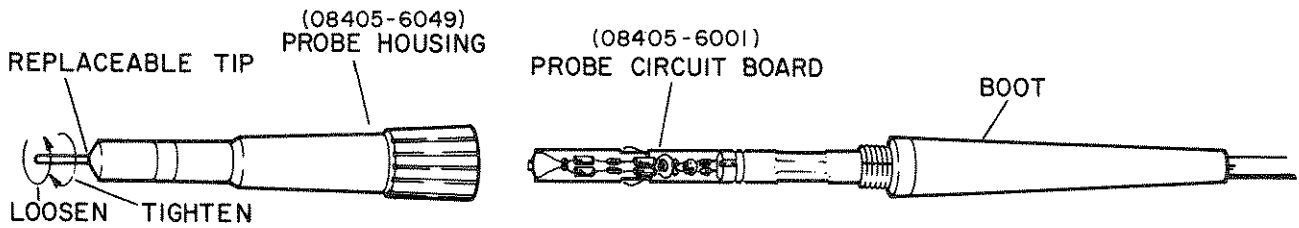

"B" Type Probe: The Second Generation Probe

Shipment Dates: January 1967 through August 1967
 Serial Numbers: 645-00661 through 725-01110
 Identifying Feature: Probe tip screws into probe housing

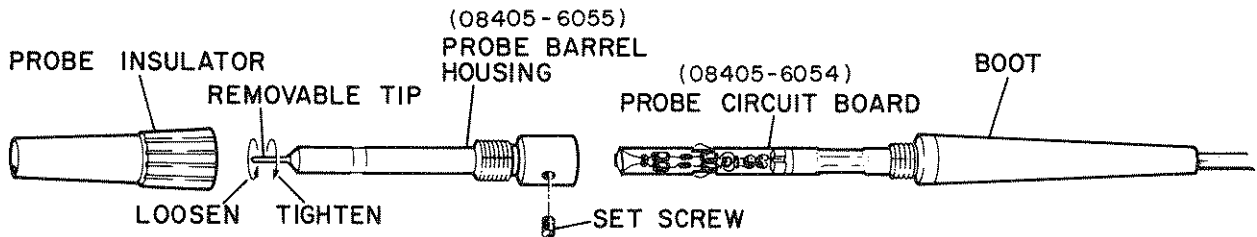

"C" Type Probe: The Final Probe

Shipment Dates: September 1967 to Present
 Serial Numbers: 732-01111 and up
 Identifying Feature: Probe housing consists of two parts, barrel and insulator

Figure 3. Three Types of Probes

