



**Agilent Technologies**

---

# Agilent 8473B/C Crystal Detector

**Operating and Service  
Manual**

---

Agilent Part Number: 08473-90003  
Printed in USA  
Print Date: June 2001  
Supersedes: May 1990

---

## Notice

The information contained in this document is subject to change without notice.

Agilent Technologies makes no warranty of any kind with regard to this material, including, but not limited to, the implied warranties of merchantability and fitness for a particular purpose. Agilent Technologies shall not be liable for errors contained herein or for incidental or consequential damages in connection with the furnishing, performance, or use of this material.

Agilent Technologies assumes no responsibility for the use or reliability of its software on equipment that is not furnished by Agilent Technologies.

This document contains proprietary information which is protected by copyright. All rights are reserved. No part of this document may be photocopied, reproduced, or translated to another language without prior written consent of Agilent Technologies.

### RESTRICTED RIGHTS LEGEND

Use, duplication, or disclosure by the U.S. Government is subject to restrictions as set forth in subparagraph (c)(1)(ii) of the Rights in Technical Data and Computer Software clause at DFARS 252.227-7013 for DOD agencies, and subparagraphs (c)(1) and (c)(2) of the Commercial Computer Software Restricted Rights clause at FAR 52.227-19 for other agencies.

Agilent Technologies, Inc.  
1400 Fountaingrove Parkway  
Santa Rosa, CA 95403-1799, U.S.A.

© Copyright 1990, 2001 Agilent Technologies, Inc.

---

## In This Manual...

- **Overview**, page 1
- **Specifications**, page 2
- **Installation**, page 4
- **Storage and Shipment**, page 5
- **Operation**, page 6
  - **Operator's Checks**, page 8
- **Performance Tests**, page 9
  - **Adjustments**, page 10
- **Service**, page 11
  - "Replaceable Parts" on page 11

---

## Warranty

Custom systems are warranted by contractual agreement between Agilent Technologies and the customer.

## Certification

*Agilent Technologies, Inc., certifies that this product met its published specifications at the time of shipment from the factory. Agilent Technologies further certifies that its calibration measurements are traceable to the United States National Institute of Standards and Technology (NIST, formerly NBS), to the extent allowed by the Institute's calibration facility, and to the calibration facilities of other International Standards Organization members.*

## Warranty

This Agilent Technologies system product is warranted against defects in materials and workmanship for a period corresponding to the individual warranty periods of its component products. Instruments are warranted for a period of one year. During the warranty period, Agilent Technologies will, at its option, either repair or replace products that prove to be defective.

Warranty service for products installed by Agilent Technologies and certain other products designated by Agilent Technologies will be performed at Buyer's facility at no charge within Agilent Technologies service travel areas. Outside Agilent Technologies service travel areas, warranty service will be performed at Buyer's facility only upon Agilent Technologies' prior agreement and Buyer shall pay Agilent Technologies' round trip travel expenses. In all other areas, products must be returned to a service facility designated by Agilent Technologies.

For products returned to Agilent Technologies for warranty service, Buyer shall prepay shipping charges to Agilent Technologies and Agilent Technologies shall pay shipping charges to return the product to Buyer. However, Buyer shall pay all shipping charges, duties, and taxes for products returned to Agilent Technologies from another country.

Agilent Technologies warrants that its software and firmware designated by Agilent Technologies for use with an instrument will execute its programming instructions when properly installed on that instrument. Agilent Technologies does not warrant that the operation of the instrument, or software, or firmware will be uninterrupted or error free.

**LIMITATION OF WARRANTY.** The foregoing warranty shall not apply to defects resulting from improper or inadequate maintenance by Buyer, Buyer-supplied software or interfacing, unauthorized modification or misuse, operation outside of the environmental specifications for the product, or improper site preparation or maintenance.

NO OTHER WARRANTY IS EXPRESSED OR IMPLIED. AGILENT TECHNOLOGIES SPECIFICALLY DISCLAIMS THE IMPLIED WARRANTIES OR MERCHANTABILITY AND FITNESS FOR A PARTICULAR PURPOSE.

**EXCLUSIVE REMEDIES.** THE REMEDIES PROVIDED HEREIN ARE BUYER'S SOLE AND EXCLUSIVE REMEDIES. AGILENT TECHNOLOGIES SHALL NOT BE LIABLE FOR ANY DIRECT, INDIRECT, SPECIAL, INCIDENTAL, OR CONSEQUENTIAL DAMAGES, WHETHER BASED ON CONTRACT, TORT, OR ANY OTHER LEGAL THEORY.

**YEAR 2000.** Agilent Technologies warrants that each Agilent Technologies hardware, software, and firmware product on Agilent Technologies' Corporate Price List (dated July 1, 1998 or later) delivered under the product's contract of sale will be able to accurately process date data (including, but not limited to, calculating, comparing, and sequencing) from, into, and between the twentieth and twenty-first centuries, and the years 1999 and 2000, including leap year calculations, when used in accordance with the product documentation provided that all other products (that is, hardware, software, firmware) used in combination with such Agilent Technologies product(s) properly exchange date data with it. If the agreement requires that specific Agilent Technologies products must perform as a system in accordance with the foregoing warranty, then that warranty will apply to those Agilent Technologies products as a system, and Customer retains sole responsibility to ensure the year 2000 readiness of its information technology and business environment. The duration of this warranty extends through January 31, 2001.

The remedies available under this warranty will be defined in, and subject to, the terms and limitations of the warranties contained in the contract of sale. To the extent permitted by local law, this warranty applies only to branded Agilent Technologies products and not to products manufacture by others that may be sold or distributed by Agilent Technologies. Nothing in this warranty will be construed to limit any rights or remedies provided elsewhere in the contract of sale with respect to matters other than year 2000 compliance.

## **Assistance**

Product maintenance agreements and other customer assistance agreements are available for Agilent Technologies products.

For assistance, call your local Agilent Technologies Sales and Service Office (refer to [“Service and Support” on page vii](#)).

---

## Service and Support

By internet, phone, or fax, get assistance with all your test and measurement needs.

**Online assistance:** [www.agilent.com/find/assist](http://www.agilent.com/find/assist)

---

<b>United States</b> (tel) 1 800 452 4844	<b>Latin America</b> (tel) (305) 269 7500 (fax) (305) 269 7599	<b>Canada</b> (tel) 1 877 894 4414 (fax) (905) 282-6495	<b>Europe</b> (tel) (+31) 20 547 2323 (fax) (+31) 20 547 2390
<b>New Zealand</b> (tel) 0 800 738 378 (fax) (+64) 4 495 8950	<b>Japan</b> (tel) (+81) 426 56 7832 (fax) (+81) 426 56 7840	<b>Australia</b> (tel) 1 800 629 485 (fax) (+61) 3 9210 5947	

---

### Asia Call Center Numbers

Country	Phone Number	Fax Number
Singapore	1-800-375-8100	(65) 836-0252
Malaysia	1-800-828-848	1-800-801664
Philippines	(632) 8426802 1-800-16510170 (PLDT Subscriber Only)	(632) 8426809 1-800-16510288 (PLDT Subscriber Only)
Thailand	(088) 226-008 (outside Bangkok) (662) 661-3999 (within Bangkok)	(66) 1-661-3714
Hong Kong	800-930-871	(852) 2506 9233
Taiwan	0800-047-866	(886) 2 25456723
People's Republic of China	800-810-0189 (preferred) 10800-650-0021	10800-650-0121
India	1-600-11-2929	000-800-650-1101

---

## Safety and Regulatory Information

Review this product and related documentation to familiarize yourself with safety markings and instructions before you operate the instrument. This product has been designed and tested in accordance with international standards.

---

### WARNING

---

**The WARNING notice denotes a hazard. It calls attention to a procedure, practice, or the like, that, if not correctly performed or adhered to, could result in personal injury. Do not proceed beyond a WARNING notice until the indicated conditions are fully understood and met.**

---

### CAUTION

---

The CAUTION notice denotes a hazard. It calls attention to an operating procedure, practice, or the like, which, if not correctly performed or adhered to, could result in damage to the product or loss of important data. Do not proceed beyond a CAUTION notice until the indicated conditions are fully understood and met.

## Instrument Markings



When you see this symbol on your instrument, you should refer to the instrument's instruction manual for important information.



This symbol indicates hazardous voltages.



The laser radiation symbol is marked on products that have a laser output.



This symbol indicates that the instrument requires alternating current (ac) input.



The CE mark is a registered trademark of the European Community. If it is accompanied by a year, it indicates the year the design was proven.

The C-Tick mark is a registered trademark of the Australian Spectrum Agency.



The CSA mark is a registered trademark of the Canadian Standards Association.

---



---

1SM1-A

This text indicates that the instrument is an Industrial Scientific and Medical Group 1 Class A product (CISPER 11, Clause 4).

---



This symbol indicates that the power line switch is ON.

---



This symbol indicates that the power line switch is OFF or in STANDBY position.

---



## **Safety Earth Ground**

This is a Safety Class I product (provided with a protective earthing terminal). An uninterruptible safety earth ground must be provided from the main power source to the product input wiring terminals, power cord, or supplied power cord set. Whenever it is likely that the protection has been impaired, the product must be made inoperative and secured against any unintended operation.

## **Before Applying Power**

Verify that the product is configured to match the available main power source as described in the input power configuration instructions in this manual. If this product is to be powered by autotransformer, make sure the common terminal is connected to the neutral (grounded) side of the ac power supply.

---

## Overview

This manual contains operating instructions for the Agilent Technologies 8473B and 8473C Crystal Detectors. Included in the manual is the information required to install and test the crystal detector.

## Description

The Agilent 8473B and 8473C crystal detector is a 50W (nominal) device designed for measurement use in coaxial systems. The detector converts RF power levels applied to the 50W input connector into proportional values of dc voltage. The RF input connector is a male APC 3.5 type connector (SMA compatible). The detector module uses a Low Barrier Schottky diode and thin film matching circuit that yield high sensitivity and broadband performance. The detector measures relative power up to 200mW and has a BNC female connector for the output jack which allows the detected output to be connected to a SWR meter. The output voltage polarity is negative, unless Option 003 is selected. The frequency range is 10 MHz to 18 GHz for the 8473B, and 10 MHz to 26.5 GHz for the 8473C. Complete specifications for the crystal detectors are available in [Table 1](#).

## Options

The crystal detector is available with the following options (see [Table 1](#) for further descriptions):

### **Option 001:**

Matched pair of detectors.

### **Option 002:**

Square law load.

### **Option 003:**

Positive polarity output.

## Specifications

Instrument specifications are listed in [Table 1](#). These specifications are the performance standards, or limits against which the instrument may be tested.

---

**NOTE**

---

RF may leak through the output connector, especially below 1 GHz. It can be reduced, if objectionable, with a suitable low-pass filter.

**Table 1** *Specifications*

	8473B	8473C
Frequency range (GHz)	0.01 to 18	0.01 to 26.5
Frequency response <sup>1, 2, 3</sup>	±0.2 dB over any octave to 8 GHz 0.01 to 12.4 GHz: ±0.3 dB 0.01 to 18 GHz: ±0.6 dB	±0.2 dB over any octave to 8 GHz 0.01 to 12.4 GHz: ±0.3 dB 0.01 to 20 GHz: ±0.6 dB 20 to 26.5 GHz: ±1.5 dB from a –3.3 dB linear slope.
Maximum Operating input power	200 mW, peak or average	200 mW, peak or average
Maximum short term input power	1 watt (typical) peak or average for <1 minute	1 watt (typical) peak or average for <1 minute
Sensitivity <sup>1, 4</sup>		
Low level <–20 dBm	>0.5 mV/ μW	0.01 to 18 GHz: >0.5 mV/ μW 18 to 26.5 GHz: >0.18 mV/ μW
High level	<0.35 mW produces 100 mV output	<–0.35 mW produces 100 mV output up to 18 GHz
SWR <sup>1, 2</sup>	0.01 to 4 GHz: 1.2 4 GHz to 18 GHz: 1.5	0.01 to 4 GHz: 1.2 4 to 18 GHz: 1.5 18 to 26.5 GHz: 2.2
Input impedance	50Ω (nominal)	50Ω (nominal)
Output impedance <sup>2</sup>	1 to 2 KΩ (typically 1.3 KΩ) shunted by 20 to 60 pF (typically 30 pF)	1 to 2 KΩ (typically 1.3 KΩ) shunted by 20 to 60 pF (typically 30 pF)
Output polarity	Negative (refer to options for positive polarity units)	Negative (refer to options for positive polarity units)
Detector element	Supplied (refer to <a href="#">Table 2 on page 12</a> for replacement modules)	Supplied (refer to <a href="#">Table 2 on page 12</a> for replacement modules)
Bias	Not required	Not required
Noise	<50 μV p-p with CW applied to produce 100 mV output, 400 kHz bandwidth	<50 μV p-p with CW applied to produce 100 mV output, 400 kHz bandwidth

**Table 1 Specifications**

	8473B	8473C
<b>Options</b>		
001	Matched detector pair	Matched detector pair
Frequency response characteristics (exclusive of basic sensitivity) track within values listed to the right.	0.01 to 12.4 GHz: $\pm 0.2$ dB 0.01 to 18 GHz: $\pm 0.3$ dB	0.01 to 12.4 GHz: $\pm 0.2$ dB 0.01 to 18 GHz: $\pm 0.3$ dB 0.01 to 26.5 GHz: $\pm 0.5$ dB
002	Square law load	Square law load
By choosing Option 002, the deviation from ideal square law response will be $\pm 0.5$ dB, although the sensitivity specification is decreased by a factor of 4.		
003	Positive polarity output	Positive polarity output
<b>Environmental</b>		
Operating Temperature	$-20^{\circ}$ C to $+85^{\circ}$ C	$-20^{\circ}$ C to $+85^{\circ}$ C
Humidity	<95% relative	<95% relative
Vibration	20 G from 80 to 2,000 Hz	20 G from 80 to 2,000 Hz
Shock	100 G for 11 ms	100 G for 11 ms
Altitude	4,570 m (15, 000 ft.)	4,570 m (15, 000 ft.)
<b>General</b>		
Weight	Net 14 g (0.5 oz)	Net 14 g (0.5 oz)
Dimensions	48 mm long, 10 mm diameter (1.9 in. long, 0.38 in. diameter)	48 mm long, 10 mm diameter (1.9 in. long, 0.38 in. diameter)

1. Specifications given for  $+25^{\circ}$  C unless otherwise noted.
2. Measurement made at  $-20$  dBm.
3. See [Figure 1 on page 7](#).
4. Sensitivity decreases with increasing temperature, typically:  
0.5 dB from  $-20^{\circ}$  C to  $+25^{\circ}$  C; 0.5 dB from  $+25^{\circ}$  C to  $+40^{\circ}$  C;  
1 dB from  $+40^{\circ}$  C to  $+55^{\circ}$  C; 1.25 dB from  $+55^{\circ}$  C to  $+75^{\circ}$  C;  
1 dB from  $+75^{\circ}$  C to  $+85^{\circ}$  C.

## Installation

### Initial Inspection

Inspect the shipping container for damage. If the shipping container or cushioning material is damaged, it should be kept until the contents of the shipment have been checked for completeness and the instrument has been checked mechanically and electrically.

The procedures for checking electrical performances are given under [“Performance Tests” on page 9](#). If the contents are incomplete, if there is mechanical damage or defect, or if the instrument does not pass the electrical performance test, notify the nearest Agilent office (refer to [“Service and Support” on page vii](#)). If the shipping container is damaged, or the cushioning material shows signs of stress, notify the carrier as well as the Agilent office. Keep the shipping materials for the carrier’s inspection. At Agilent’s option, the office will arrange for repair or replacement without waiting for claim settlement.

### Mating Connectors

The mating output connector used with the crystal detector must be a male BNC connector. The mating RF input connector must be a female APC 3.5 (SMA compatible) connector.

---

## Storage and Shipment

### Environment

The instrument should be stored in a clean, dry environment. The following environmental limitations apply to both storage and shipment:

- a. Temperature:  $-54^{\circ}\text{C}$  to  $+85^{\circ}\text{C}$
- b. Humidity:  $<95\%$  relative
- c. Altitude:  $<7,620$  metres (25,000 feet)
- d. Shock: 100 G for 11 ms
- e. Vibration: 20 G from 80 to 2,000 Hz

### Original Packaging

Containers and materials identical to those used in factory packaging are available through Agilent offices. If the instrument is being returned to Agilent for servicing, attach a tag indicating the type of service required, return address, model number, and serial number. Also, mark the container FRAGILE to assure careful handling. In any correspondence, refer to the instrument by model number and serial number.

---

## Operation

---

### CAUTION

Static discharge can damage the detector module. A 100 pF capacitor (1.2 m [4 ft.] of coax cable) charged to 14 volts stores  $10^{-8}$  joules, the maximum pulse rating of the detector module. Connect cables to test equipment and discharge the center conductor before connecting to the detector.

---

### CAUTION

DO NOT NEEDLESSLY HANDLE DETECTOR MODULE USED IN CRYSTAL DETECTOR. Static electricity which builds up on a person, especially on a cold dry day, must never be allowed to discharge through the crystal detector. Avoid exposed leads to or from the crystal detector, since these are often touched accidentally.

---

## Operating Information

The crystal detector can be used as a demodulator to obtain a pulse envelope which can then be observed on an oscilloscope. It can also be used as a general purpose detector.

When using the detector with an oscilloscope, and the waveshapes to be observed have rise times of less than 5 ms, the coaxial cable connecting oscilloscope and detector should be as short as possible and shunted with a resistor. Ideally, this resistor should be 50W to terminate the coaxial cable properly. However, with 50W resistance, the output video pulse may be too small to drive some oscilloscopes. Therefore, the cable should be shunted with the smallest value of resistance that will obtain suitable deflection on the oscilloscope; typically the value will lie between 50W and 2 KW. The larger the resistance the more degradation of rise time.

The power applied to the detector can be either modulated or continuous wave (CW). If modulated at a 1,000 Hz rate, an SWR meter can be used as an indicator. For CW detection, a dc milliammeter or millivoltmeter can be used as the indicator.

## Frequency Response

The thin film input matching circuit was optimized for flat frequency response, and low SWR which yields improved performance in leveling loops and power monitoring applications. **Figure 1** shows the typical frequency response of the crystal detector.

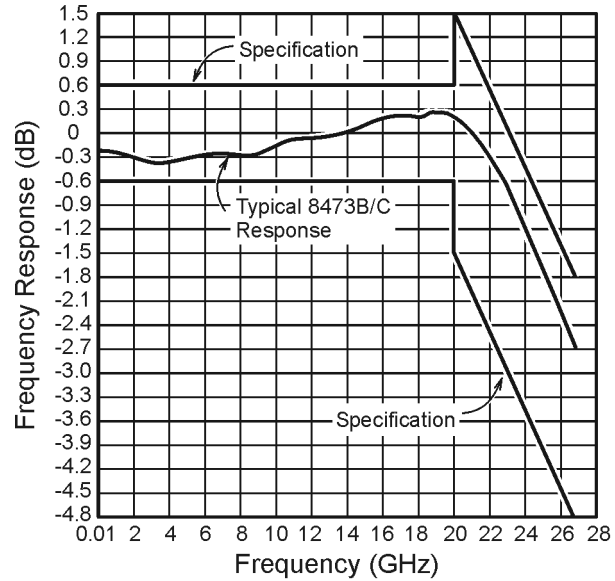

ao101b

**Figure 1** Typical Frequency Response of 8473B or 8473C Detector

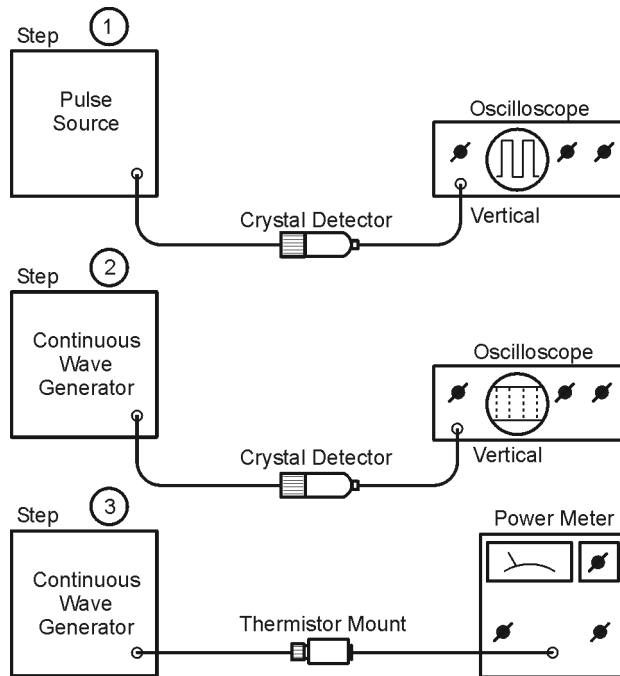

ao102b

**Figure 2** Peak Power Measurement



## Operator's Checks

### Peak Power Measurement

The arrangement of equipment for peak power measurement is shown in [Figure 2](#). The procedure involves calibration of an oscilloscope which, in turn, is used to calibrate a CW generator. The output of the calibrated CW generator is measured with a power meter; the peak power of a pulse is thereby measured. The procedure is as follows:

1. Connect equipment as shown in [Figure 2](#), step 1. Observe pulse on a dc-coupled oscilloscope. Using a marking pencil, mark on the graticule the base-to-peak amplitude of the pulse envelope.
2. Replace the pulse source with a CW generator. While observing the oscilloscope trace, adjust amplitude of CW generator output to make detector output equal to that of the pulse generator, as indicated by markings on graticule (step 1).
3. Leave CW generator at setting obtained in step 2. Disconnect detector from CW generator. Connect output of CW generator to power meter. Measure adjusted levels (set in step 2) of CW generator output. The peak power of the pulse envelope observed in step 1 is equal to the output power of the CW generator.

---

## Performance Tests

The following paragraphs suggest methods to use for testing detector specifications. For these tests refer to the manuals of the equipment involved for operating instructions.

### Frequency Response Test

1. Using signal sources covering 10 MHz to 26.5 GHz with a 10 dB isolating attenuator and a power meter, connect power sensor to attenuator. Adjust RF power level to -20 dBm input to power sensor.
2. Without changing RF power level of signal source, disconnect power sensor.
3. Connect detector to attenuator. Measure dc voltage output from detector output from detector and record measurement.
4. Change frequency of signal source and repeat [steps 1](#) through [3](#).
5. Since the detector follows a square-law response at this power level, it's output is proportional to power ( $P_{dB}$  a  $10 \log V_o$ ). Total variation of detector readings should meet specifications (see [Table 1 on page 2](#)) for all frequencies of interest across the band.

---

#### NOTE

Multiple mismatch errors caused by attenuator SWR, power sensor SWR, and detector SWR should be taken into account, as well as the accuracy of the indicator used to measure the detector output.

---

### High Level Sensitivity Test

1. Use a signal source at some convenient frequency between 10 MHz and 18 GHz and a dc voltmeter or oscilloscope as the indicator. Connect the detector to signal source and adjust RF power level for a 100 mV detected output from detector.
2. Disconnect detector from signal source and measure RF output level. The RF output level should be  $\approx 0.35$  mW.

## Low Level Sensitivity Test

1. Use a signal source covering 10 MHz to 18 GHz for the 8473B or 10 MHz to 26.5 GHz for the 8473C, a 10 dB attenuator, and a power meter. Connect attenuator to signal source and power sensor to attenuator. Adjust RF power level for -20 dBm output from attenuator. Verify the ambient temperature.
2. Disconnect power sensor from attenuator and connect detector. Measure the dc voltage output from detector. The output should be >5.0 mV up to 18 GHz for the 8473B/C and >1.8 mV from 18 to 26.5 GHz for the 8473C at 25°C. Between 20°C and 30°C with -20 dBm input power and a high impedance video load the sensitivity slope is typically -0.04 dB/°C.

---

### NOTE

---

Multiple mismatch errors caused by attenuator SWR, power sensor SWR, and detector SWR should be taken into account, as well as accuracy of the indicator used to measure detector output.

## Match Test (SWR)

To verify the detector SWR specifications, use any system whose measurement accuracies for SWR (residual SWR) are known.

## Adjustments

The detector has no internal adjustments.

---

## Service

The succeeding paragraphs give instructions for repair of the crystal detector. Additional maintenance information can be obtained from the local Agilent office. Part numbers for replaceable parts are given in [Table 2 on page 12](#).

### Replaceable Parts

To order a replaceable part, address order or inquiry to the nearest Agilent office (refer to [“Service and Support” on page vii](#)). Include the following information for each part: model number, Agilent part number, and description.

### Diode Module Replacement

The diode module assembly includes the sealed diode and thin film matching circuit. All other internal parts are to be retained for re-use in the detector. The detector is operational after the diode module has been replaced since replacement assemblies are pre-tested.

---

#### CAUTION

---

The special diode module (see [Figure 3 on page 13](#)) contained in the detector can be damaged in handling, removal, or installation if certain precautions are not taken. The handling precautions which follow should be read before performance of any operation with the diode module when it is out of either the housing or the module shipping container.

- a. Before installing diode module into housing, touch exposed metal on housing with your hand to discharge static electricity. Then insert module into housing.
- b. When handing diode to another person, touch hands first to ensure there is no difference in static electricity potential between you.
- c. Ohmmeters should not be used to measure forward and back resistance since it is easy to damage these diodes. The difficulty arises because of the ohmmeter's open-circuit voltages and short currents.

## Replacing Diode Module

---

### CAUTION

---

The diode module can be damaged in handling or installation if precautions are not taken. Before installing the diode module into the connector housing, touch the exposed metal of the connector housing with your hands to discharge static electricity.

**Table 2 Replaceable Parts**

Description	Part Number	
<b>8473B and 8473C Assemblies<sup>1</sup></b>		
BNC Connector Cap	1250-1514	
Output Pin	08473-60001	
RF Connector Housing	08473-60002	
RF Washer (2)	33330-20006	
Diode Module	Below	
<b>Replacement Diode Module Assemblies<sup>1</sup></b>	<b>8473B</b>	<b>8473C</b>
Single Diode Negative Polarity	08473-80001	08473-80004
Single Diode Positive Polarity (Option 003)	08473-80003	08473-80006
Matched Pair Diodes Negative Polarity (Option 001)	08473-80002	08473-80005

1. Refer to [Table 1 on page 2](#) for description of options.

---

### NOTE

---

Parts mentioned in the following procedure are identified in [Figure 3 on page 13](#).

1. Remove the RF connector housing from BNC connector cap using 5/16 inch wrench and plastic jaw pliers. Protect crystal detector body with heavy paper or tape.
2. Remove the diode module RF washer and output pin assembly.

---

### CAUTION

---

Do not rotate module while inserting or removing; damage may result.

---

### CAUTION

---

When inserting diode module (large pin end) into center conductor, exercise some restraint, do not force. The fingers of the center conductor or the diode module might be damaged if the module is not centered.

3. Install the RF washer and diode module as shown in [Figure 3](#). Insert the larger diameter pin into the center conductor contacts of the RF connector housing. Do not rotate the module.
4. Place the other RF washer on the diode module as shown.
5. Install the output pin assembly on the diode module as shown.
6. Carefully place BNC connector cap over the diode module and tighten firmly into place.

---

**CAUTION**

---

Do not exceed 0.8 N·m (7 inch-lbs) torque.

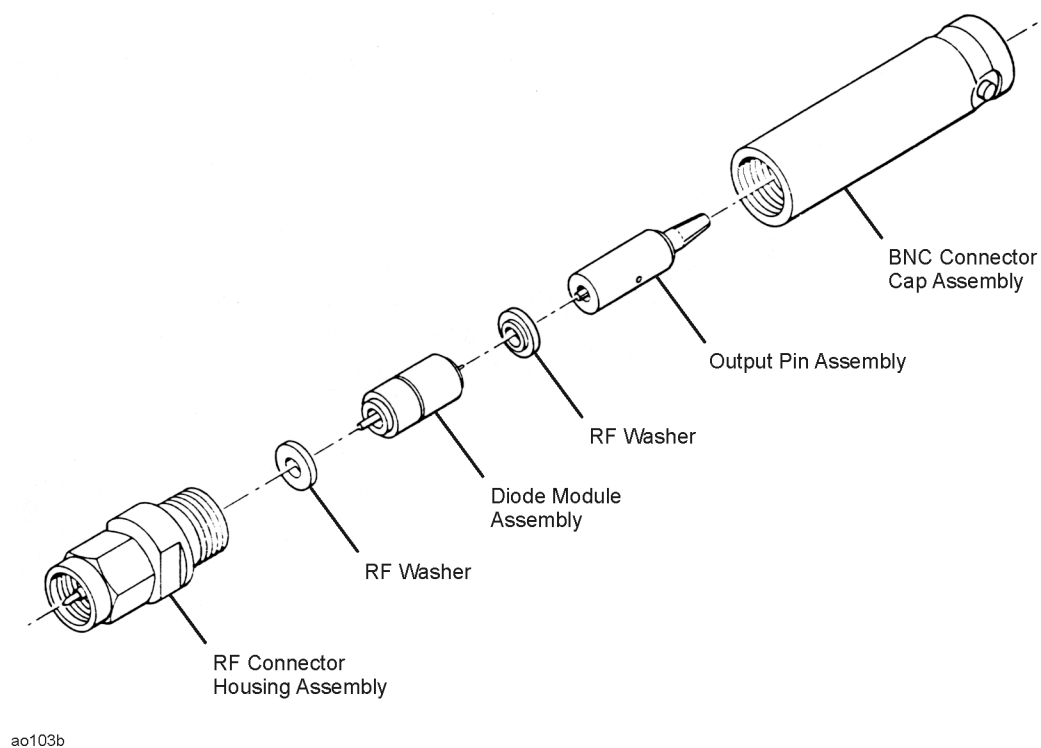

**Figure 3 Model 8473B or 8473C Crystal Detector Assembly**