

Agilent Technologies

8924E CDMA Mobile Station Test Set

Introduction to Operation

Firmware Version A.03.02 and above

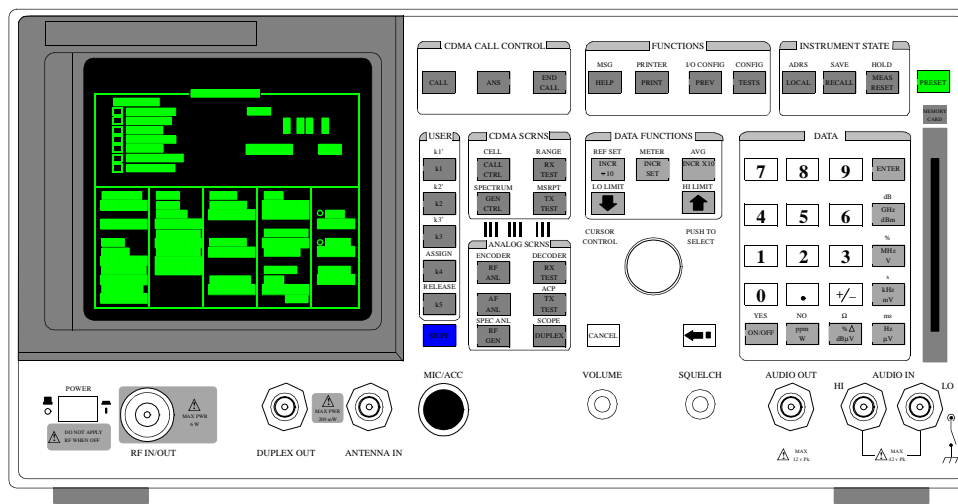

Agilent Part Number: 08924-90058
Printed in U. S. A.
March 2000

Rev. C

© Copyright Agilent Technologies 1998, 2000

Notice

Information contained in this document is subject to change without notice.

All Rights Reserved. Reproduction, adaptation, or translation without prior written permission is prohibited, except as allowed under the copyright laws.

This material may be reproduced by or for the U.S. Government pursuant to the Copyright License under the clause at DFARS 52.227-7013 (APR 1988).

Agilent Technologies, Inc.
Learning Products Department
24001 E. Mission
Liberty Lake, WA 99019-9599
U.S.A.

Manufacturer's Declaration

This statement is provided to comply with the requirements of the German Sound Emission Directive, from 18 January 1991. This product has a sound pressure emission (at the operator position) < 70 dB(A).

- Sound Pressure $L_p < 70$ dB(A).
- At Operator Position.
- Normal Operation.
- According to ISO 7779:1988/EN 27779:1991 (Type Test).

Herstellerbescheinigung

Diese Information steht im Zusammenhang mit den Anforderungen der Maschinenlärminformationsverordnung vom 18 Januar 1991.

- Schalldruckpegel $L_p < 70$ dB(A).
- Am Arbeitsplatz.
- Normaler Betrieb.
- Nach ISO 7779:1988/EN 27779:1991 (Typprüfung).

Safety Considerations

GENERAL

This product and related documentation must be reviewed for familiarization with safety markings and instructions before operation.

This product has been designed and tested in accordance with *IEC Publication 1010*, "Safety Requirements for Electronic Measuring Apparatus," and has been supplied in a safe condition. This instruction documentation contains information and warnings which must be followed by the user to ensure safe operation and to maintain the product in a safe condition.

SAFETY EARTH GROUND

A uninterruptible safety earth ground must be provided from the main power source to the product input wiring terminals, power cord, or supplied power cord set.

CHASSIS GROUND TERMINAL

To prevent a potential shock hazard, always connect the rear-panel chassis ground terminal to earth ground when operating this instrument from a dc power source.

SAFETY SYMBOLS



Indicates instrument damage can occur if indicated operating limits are exceeded.



Indicates hazardous voltages.



Indicates earth (ground) terminal

WARNING

A WARNING note denotes a hazard. It calls attention to a procedure, practice, or the like, which, if not correctly performed or adhered to, could result in personal injury. Do not proceed beyond a WARNING sign until the indicated conditions are fully understood and met.

CAUTION

A CAUTION note denotes a hazard. It calls attention to an operation procedure, practice, or the like, which, if not correctly performed or adhered to, could result in damage to or destruction of part or all of the product. Do not proceed beyond a CAUTION note until the indicated conditions are fully understood and met.

Safety Considerations for this Instrument

WARNING

This product is a Safety Class I instrument (provided with a protective earthing ground incorporated in the power cord). The mains plug shall only be inserted in a socket outlet provided with a protective earth contact. Any interruption of the protective conductor inside or outside of the product is likely to make the product dangerous. Intentional interruption is prohibited..

Whenever it is likely that the protection has been impaired, the instrument must be made inoperative and be secured against any unintended operation.

If this instrument is to be energized via an autotransformer (for voltage reduction), make sure the common terminal is connected to the earth terminal of the power source.

If this product is not used as specified, the protection provided by the equipment could be impaired. This product must be used in a normal condition (in which all means for protection are intact) only.

No operator serviceable parts in this product. Refer servicing to qualified personnel. To prevent electrical shock, do not remove covers.

Servicing instructions are for use by qualified personnel only. To avoid electrical shock, do not perform any servicing unless you are qualified to do so.

The opening of covers or removal of parts is likely to expose dangerous voltages. Disconnect the product from all voltage sources while it is being opened.

Adjustments described in the manual are performed with power supplied to the instrument while protective covers are removed. Energy available at many points may, if contacted, result in personal injury.

The power cord is connected to internal capacitors that may remain live for 5 seconds after disconnecting the plug from its power supply.

For Continued protection against fire hazard, replace the line fuse(s) only with 250 V fuse(s) or the same current rating and type (for example, normal blow or time delay). Do not use repaired fuses or short circuited fuseholders.

CAUTION:

Always use the three-prong ac power cord supplied with this product. Failure to ensure adequate earth grounding by not using this cord may cause product damage.

This product is designed for use in Installation Category II and Pollution Degree 2 per *IEC 1010* and *IEC 664* respectively.

This product has autoranging line voltage input, be sure the supply voltage is within the specified range.

Ventilation Requirements: When installing the product in a cabinet, the convection into and out of the product must not be restricted. The ambient temperature (outside the cabinet) must be less than the maximum operating temperature of the product by 4° C for every 100 watts dissipated in the cabinet. If the total power dissipated in the cabinet is greater than 800 watts, then forced convection must be used.

Product Markings CE - the CE mark is a registered trademark of the European Community. A CE mark accompanied by a year indicated the year the design was proven.

CSA - the CSA mark is a registered trademark of the Canadian Standards Association.

Agilent Technologies Warranty Statement for Commercial Products

Agilent
Technologies
8924E CDMA
Mobile Station
Test Set

Duration of Warranty: 1 year

1. Agilent Technologies warrants Agilent Technologies Agilent Technologies hardware, accessories and supplies against defects in materials and workmanship for the period specified above. If Agilent Technologies receives notice of such defects during the warranty period, Agilent Technologies will, at its option, either repair or replace products which prove to be defective. Replacement products may be either new or like-new.
2. Agilent Technologies warrants that Agilent Technologies software will not fail to execute its programming instructions, for the period specified above, due to defects in material and workmanship when properly installed and used. If Agilent Technologies receives notice of such defects during the warranty period, Agilent Technologies will replace software media which does not execute its programming instructions due to such defects.
3. Agilent Technologies does not warrant that the operation of Agilent Technologies products will be uninterrupted or error free. If Agilent Technologies is unable, within a reasonable time, to repair or replace any product to a condition as warranted, customer will be entitled to a refund of the purchase price upon prompt return of the product.
4. Agilent Technologies products may contain remanufactured parts equivalent to new in performance or may have been subject to incidental use.
5. The warranty period begins on the date of delivery or on the date of installation if installed by Agilent Technologies. If customer schedules or delays Agilent Technologies installation more than 30 days after delivery, warranty begins on the 31st day from delivery.
6. Warranty does not apply to defects resulting from (a) improper or inadequate maintenance or calibration, (b) software, interfacing, parts or supplies not supplied by Agilent Technologies, (c) unauthorized modification or misuse, (d) operation outside of the published environmental specifications for the product, or (e) improper site preparation or maintenance.

- 7 TO THE EXTENT ALLOWED BY LOCAL LAW, THE ABOVE WARRANTIES ARE EXCLUSIVE AND NO OTHER WARRANTY OR CONDITION, WHETHER WRITTEN OR ORAL IS EXPRESSED OR IMPLIED AND AGILENT TECHNOLOGIES SPECIFICALLY DISCLAIMS ANY IMPLIED WARRANTIES OR CONDITIONS OR MERCHANTABILITY, SATISFACTORY QUALITY, AND FITNESS FOR A PARTICULAR PURPOSE.
- 8 Agilent Technologies will be liable for damage to tangible property per incident up to the greater of \$300,000 or the actual amount paid for the product that is the subject of the claim, and for damages for bodily injury or death, to the extent that all such damages are determined by a court of competent jurisdiction to have been directly caused by a defective Agilent Technologies product.
- 9 TO THE EXTENT ALLOWED BY LOCAL LAW, THE REMEDIES IN THIS WARRANTY STATEMENT ARE CUSTOMER'S SOLE AND EXCLUSIVE REMEDIES. EXCEPT AS INDICATED ABOVE, IN NO EVENT WILL AGILENT TECHNOLOGIES OR ITS SUPPLIERS BE LIABLE FOR LOSS OF DATA OR FOR DIRECT, SPECIAL, INCIDENTAL, CONSEQUENTIAL (INCLUDING LOST PROFIT OR DATA), OR OTHER DAMAGE, WHETHER BASED IN CONTRACT, TORT, OR OTHERWISE.

FOR CONSUMER TRANSACTIONS IN AUSTRALIA AND NEW ZEALAND: THE WARRANTY TERMS CONTAINED IN THIS STATEMENT, EXCEPT TO THE EXTENT LAWFULLY PERMITTED, DO NOT EXCLUDE RESTRICT OR MODIFY AND ARE IN ADDITION TO THE MANDATORY STATUTORY RIGHTS APPLICABLE TO THE SALE OF THIS PRODUCT TO YOU.

Contents

Calibrate the Test Set 17

Calibration Procedures 18

Preset the Test Set. 20

CDMA Channel Level Calibration Procedure 21

Channel Power Measurement Calibration 23

RF Generator Level Calibration (PCS Interface) 26

Average Power Measurement Zeroing 27

Correcting for RF Path Loss 31

Determining RF Path Loss 33

Contents

Set Up a Call 41

Setting Up a CDMA Call 42

Setting up a Call 43

Procedure Overview 51

Problem Solving Checklist 52

Contents

Mobile Station CDMA Tests 53

List of CDMA Tests 54

Rho (Transmitter Waveform Quality) 55

Minimum/Maximum Transmitter Power 57

FER (Frame Error Rate) 59

Measuring Access Probe Output Power 65

Performing a CDMA-to-CDMA Interband Handoff 70

Contents

Mobile Station Analog Tests 75

List of Analog Tests 76

Performing a CDMA to Analog Handoff 77

Performing an Analog Call 81

Transmitter Measurements (no audio connections required) 85

Receiver Audio Distortion and Hum and Noise (requires audio connections) 88

Transmitter Audio Distortion and Hum and Noise (requires audio connections) 93

Contents

Short Message Service Tests 97

List of CDMA SMS Tests 98

Sending Short Messages on the Paging/Access Channels 99

Sending Short Messages on the Traffic Channels 107

Contents

Authentication Tests 117

List of CDMA Authentication Tests 118

Initializing SSD to Zero 119

Updating SSD 127

Performing a Unique Challenge-Response 134

Contents

Protocol Logging 141

Hardware and Software Requirements 142

Connecting the Test Set to the Computer 144

Setting Up the Communications Package 146

Logging Protocol Messages 149

Control Commands for Protocol Logging 152

Contents

Index 157

Calibrate the Test Set

Calibration Procedures

This chapter provides step-by-step procedures for performing the Test Set's calibration routines.

To determine when each of the following calibration procedures should be performed, refer to the *Agilent 8924E Users Guide*, "Recommended Calibration Procedures."

If you are unfamiliar with the use of the cursor control knob, see "[Familiarize yourself with the CURSOR CONTROL knob.](#)" on page 19.

List of Procedures

- CDMA Channel Level calibration - 8 minutes
- Channel Power Measurement calibration - 2 minutes or more
- RF Generator Level calibration - 15 seconds
- Average Power Measurement zeroing - 2 seconds
- RF Path Loss correction

Familiarize yourself with the CURSOR CONTROL knob.

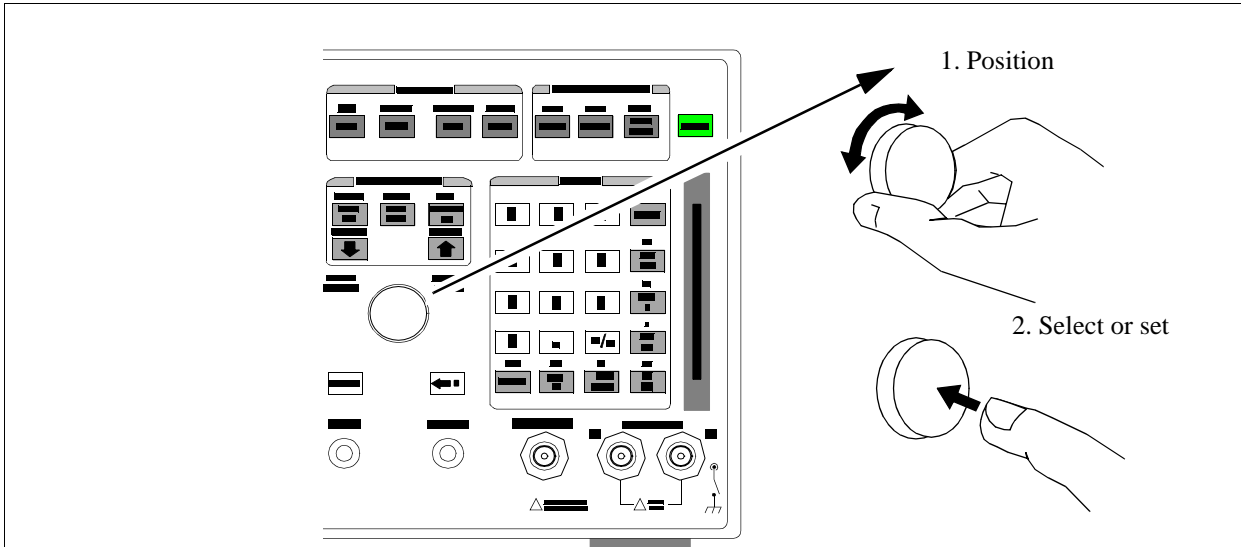

Throughout this tutorial, the terms "position," "select," and "set" are used to describe the interaction of the cursor (which appears as a small, lighted rectangular box) and the fields on the screen.

Position

To position the cursor at a field, rotate the knob to move the cursor.

Select

To select a field, position the cursor in front of a field or menu item, and then press the cursor-control knob.

When a field is selected, a selection may be underlined, a list of choices may be displayed, or the field may be highlighted to indicate that it is ready for a data entry. In some cases, a message appears at the top of the display to indicate suggested actions.

Set

To set a field, first select it, then choose a setting by either selecting from a list of choices, underlining (such as On/Off), or making a data entry.

If you are unfamiliar with operation of the Test Set, select several fields to see what happens (rotate the cursor-control knob to move the cursor to any field and press the knob), then press PRESET to reset the instrument.

Preset the Test Set.

1. If the Test Set is not powered on:
 - a. turn on power to the PCS Interface (if one is connected), then...
 - b. turn on power to the Test Set. Wait for the Test Set to complete its power-up routine
2. Press the PRESET key (to begin this procedure in a known state).

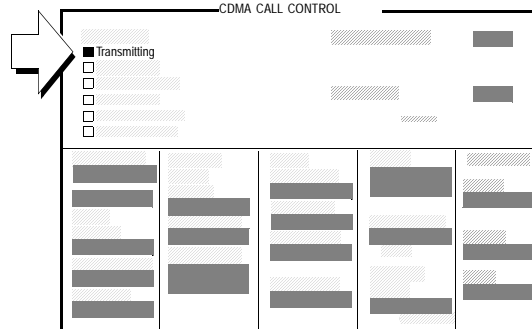

Pressing the PRESET key will configure the Test Set using factory default settings, and display the CDMA CALL CONTROL screen.

If you have the Test Set configured to operate with a PCS Interface, and you do not turn PCS Interface power on before the Test Set, the message “PCS Interface not found. Check power, cabling or CONFIG.” will be displayed. To correct this condition, follow the correct sequence of powering up these two units.

CDMA Channel Level Calibration Procedure

Approximate time: 8 minutes

1. Load the PCB_CAL procedure.

1. Press the TESTS key.
2. Select ROM from the list of choices for the Select Procedure Location field.
3. Select PCB_CAL from the list of choices for the Select Procedure Filename field.

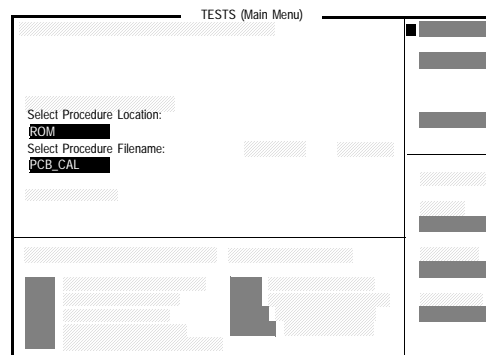

2. Run the PCB_CAL Procedure.

1. Select the Run Test field.
2. Disconnect the mobile station from the Test Set's (or PCS Interface's) RF IN/OUT port. (The Test Set beeps several times and displays the message to disconnect all front-panel cables. You only need to disconnect the RF input from the mobile.)
3. When the PCB_CAL procedure has completed, cycle power to the Test Set.

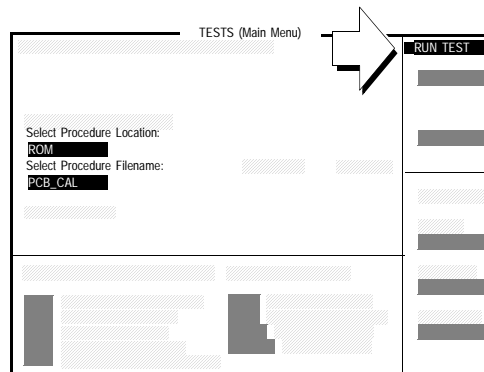

At one point in the procedure, the Test Set will beep and the message "Direct latch write occurred. Cycle power when done servicing" will appear. This is normal. Cycle power when the procedure has completed.

Procedure Overview

The Test Set optimizes the level accuracy of CDMA code channels and the AWGN (Additive White Gaussian Noise) generator by measuring the analog I/Q signals using an internal DSP-based voltmeter. Level correction factors are generated by a ROM-based program named PCB_CAL and are applied to gain control DACs, which control the fine level adjustment in the amplitude scaling path.

Calibrated channel power provides accurate values for E_b/N_t , the ratio between Traffic channel power and AWGN. It is critical that these levels remain accurate. A level accuracy error of 0.8 dB could alter FER from 0.5% to 5%.

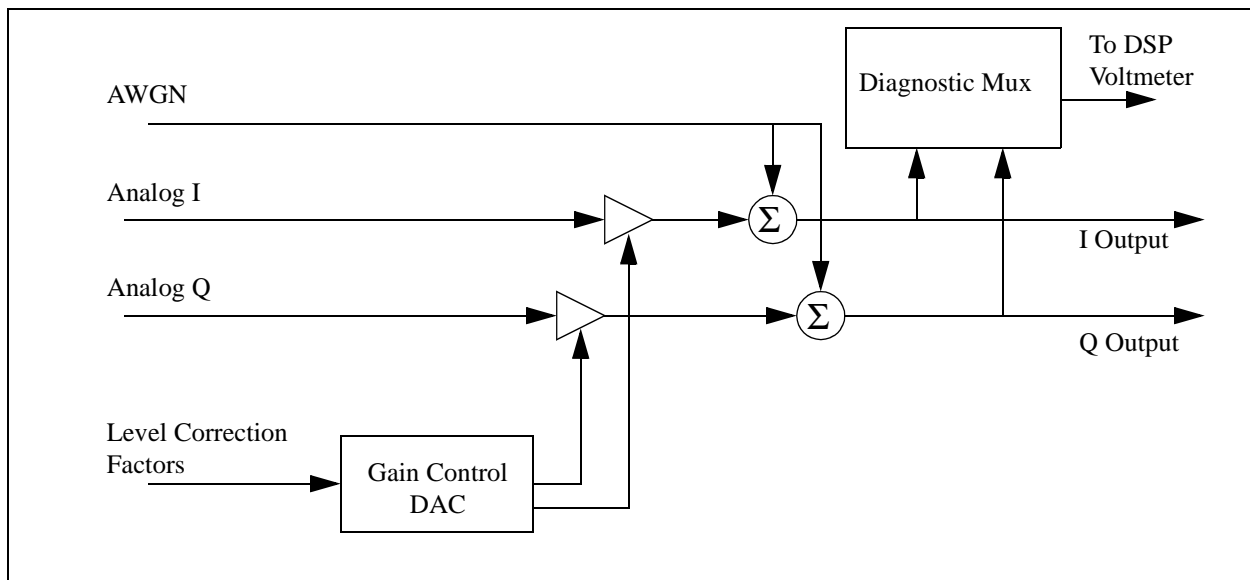

Channel Power Measurement Calibration

Approximate time: 2 minutes

1. Connect the Test Set's generator to the Test Set's analyzer.

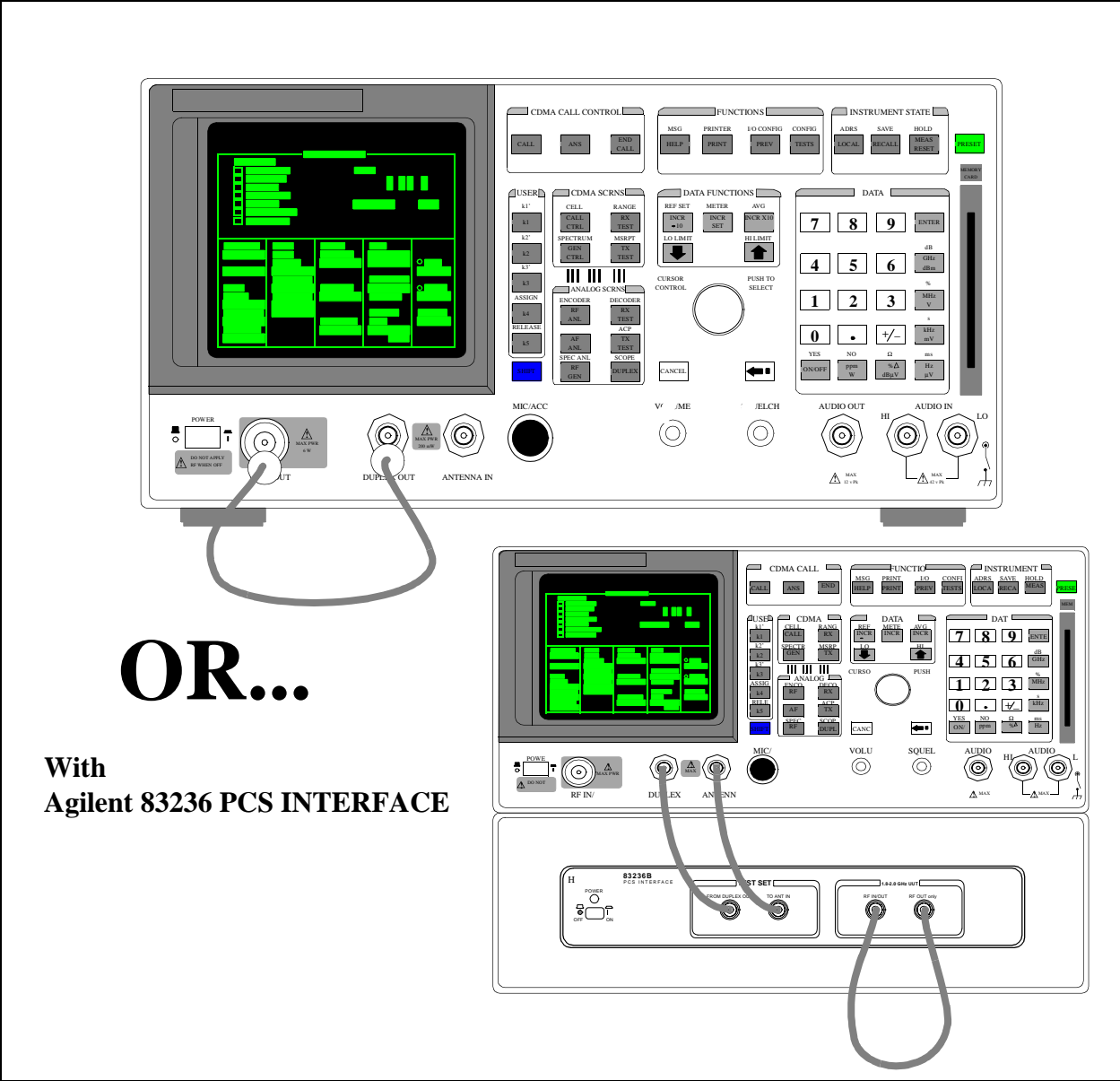

2. (Optional) Enter an alternate channel standard.

1. Press and release the SHIFT key and then press the TESTS key to display the CONFIGURE screen.
2. Select the Alt Chn Std field, and select a channel standard from the list of choices.
3. Press the PREV key to return to the CDMA CALL CONTROL screen.

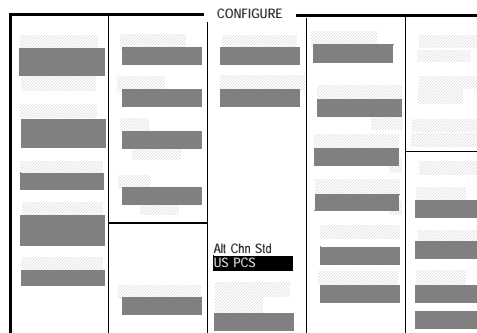

Adding an alternate channel standard will increase the time required for the Test Set to perform Channel Power Calibration, but should be performed if you will have an immediate need to test more than one type of mobile station using more than one type of RF channel standard.

3. Select the Channel Power measurement.

1. If Chan Power is not displayed in the field as shown, set this field to Chan Power.

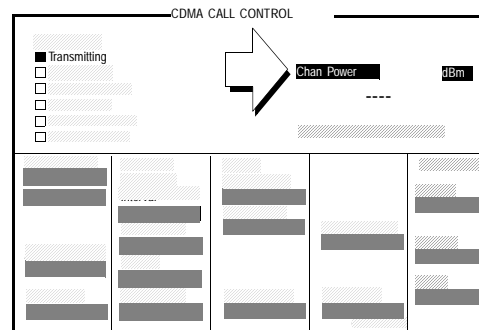

4. Calibrate the Channel Power measurement.

1. Select Calibrate to start the calibration.

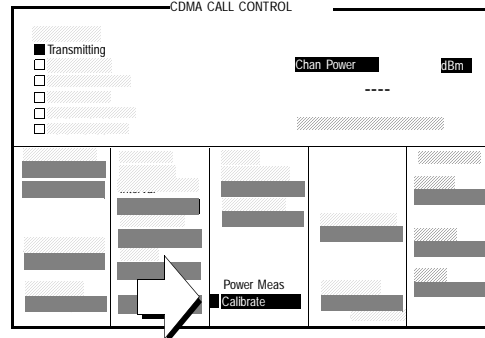

Calibration may take a minute or longer, depending on the RF Channel Std and Alt Chn Std field settings. Average Power measurements are zeroed as part of the Channel Power calibration process.

Procedure Overview

Calibrating Channel Power measurements ensures that the Test Set achieves accurate low-level CDMA power measurements.

Channel Power measurements:

- indicate power in a 1.23 MHz bandwidth
- are performed at one of the Test Set's IF frequencies by a DSP (Digital Signal Processor)
- use the Test Set's average power detector to calibrate the relative levels measured at IF.

Average Power measurements are zeroed as part of the Channel Power calibration process.

RF Generator Level Calibration (PCS Interface)

This procedure is performed only on Test Sets configured with an Agilent 83236B PCS Interface.

Approximate time: 15 seconds

1. Start calibration procedure.

1. Press and release the SHIFT key and then press the TESTS key to display the CONFIGURE screen.
2. Select the Calibrate to start the calibration.

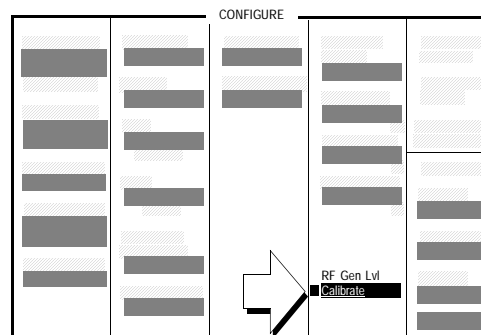

The message "Calibrating RF Generator Levels" will be displayed until the calibration process has completed.

Procedure Overview

During this procedure, the PCS Interface's internal compensation factors are used to compute attenuator path values for the PCS Interface generator and the required signal level from the Test Set's DUPLEX OUT port.

NOTE:

This procedure will cause a currently connected call to drop. (The RF IN/OUT path is momentarily de-coupled from the front panel connector during this calibration.)

Average Power Measurement Zeroing

Approximate length of time: 2 seconds

1. Remove power from the RF IN/OUT connector.

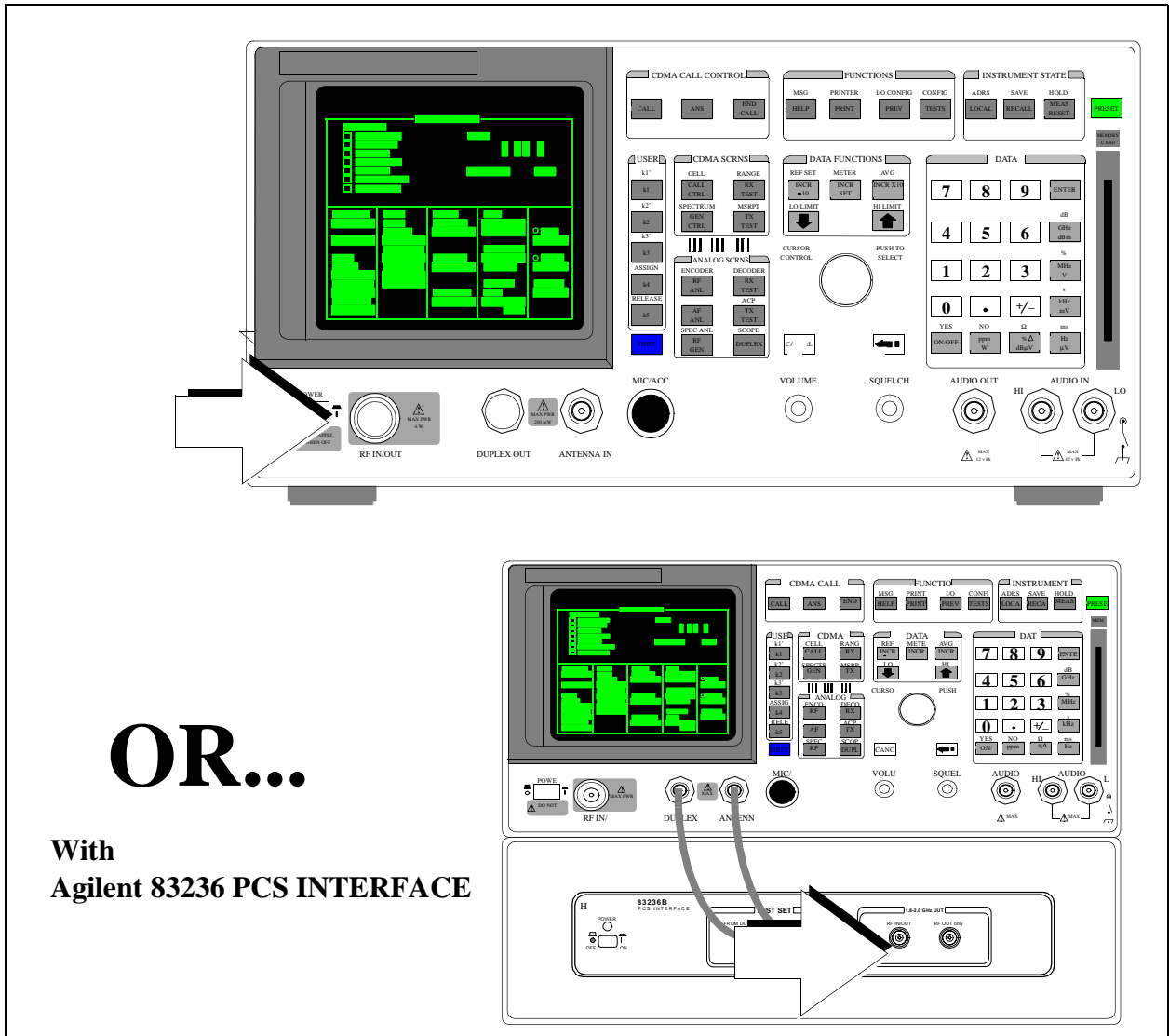

2. Check the Test Set's output power.

Manual Operation:

1. Press the GEN CTRL key to display the CDMA GENERATOR CONTROL screen.
2. If the RF Power field is displaying a value less than or equal to -75 dBm/BW, the Test Set's output power is low enough for zeroing average power measurements. Continue with the next step.

If the RF Power field is displaying a value greater than -75 dBm/BW:

Press the PRESET key. Or if you have other settings you do not want changed, turn off output power as follows:

Use the ON/OFF key along with the knob to turn off Sector A Power and AWGN.

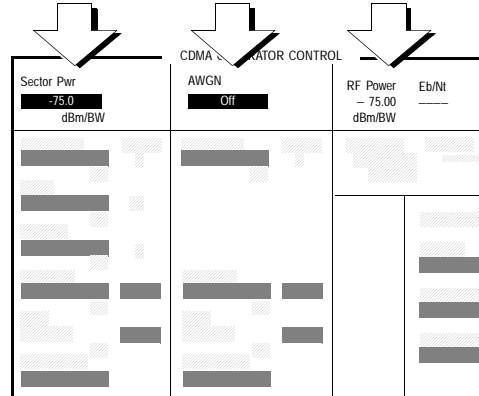

Lowering power from the CDMA generators will prevent output power from internally cross-coupling to the RF IN/OUT path during Average Power measurement zeroing.

Presetting the Test Set will turn off AWGN and will set Sector A Power to a level that is low enough to prevent cross-coupling between generator and input signal paths.

3. Select the Average Power measurement.

1. Press the CDMA SCRNS - TX TEST key to display the CDMA CELLULAR MOBILE TRANSMITTER TEST screen.
2. If Avg Power is not displayed in the field as shown, select Avg Power.

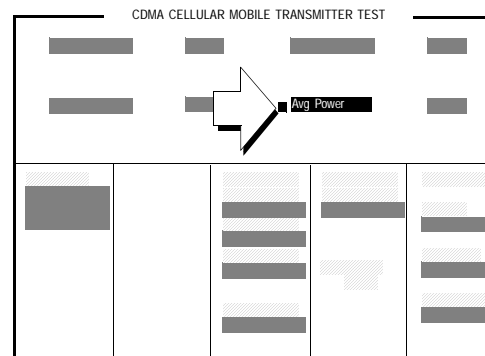

4. Zero the Average Power measurement.

1. Select Zero to zero the Average Power measurement.

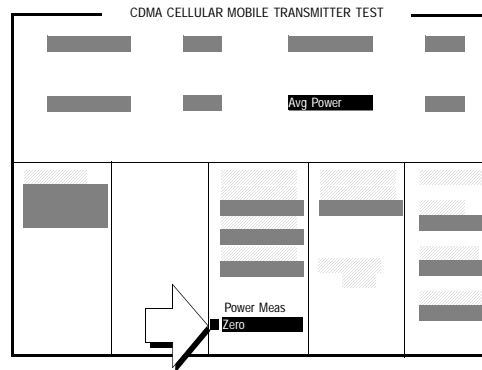

During this process, the message "Zeroing Average Power" will be displayed (for about 2 seconds).

If RF power was not lowered as shown in step 2, the Test Set will display "Zero degraded. Reduce generator level for best results."

Procedure Overview

This procedure establishes a 0 dBm reference for Average Power measurements.

Average Power measurement mode is used on higher-level signals. Lower-level power measurements are performed by the Test Set's Channel Power measurement.

NOTE:

*A misleading Average Power measurement may appear when low (or no) signal power is applied to the RF Input! When the RF generator's output port selection is **RF IN/OUT**, some of the signal energy from the Test Set's generator is detected by the Test Set's broadband average power meter. This condition does not affect typical CDMA measurements for two reasons: 1) During Average Power measurements, CDMA generator levels are too low to introduce significant energy to the power detector. 2) When the generator level is high enough to introduce significant energy to the power detector, the mobile station's signal power should be within the range of Channel Power measurements. Channel power measurements are frequency-selective, and do not detect significant energy from the Test Set's generator, which is tuned 45 MHz away from the analyzer.*

Correcting for RF Path Loss

1. Enter the (cable) path loss from the Test Set to the mobile station.

If you do not know the path loss, see "[Determining RF Path Loss](#)" on page 33

1. Press and release the SHIFT key and then press the TESTS key to display the CONFIGURE screen.

2. Select the RF In/Out field and enter a value for RF path loss.

Example: If the cable loss is 2 dB, enter -2 in the RF In/Out field.

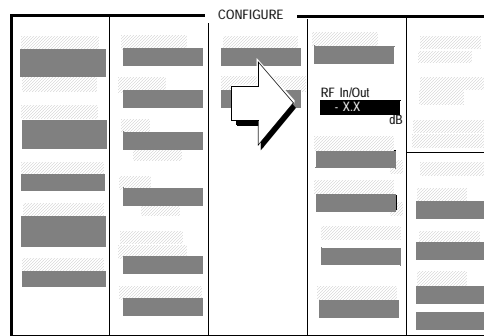

When the RF Level Offset is turned on in the next step, the displayed Average or Channel Power measurement will be increased by 2 dB and the displayed Sector A, AWGN, and RF Power outputs will be decreased by 2 dB. No actual level changes occur as a result of turning on RF Level Offset.

2. Turn on the RF Level Offset.

1. Set the RF Level Offset field to On

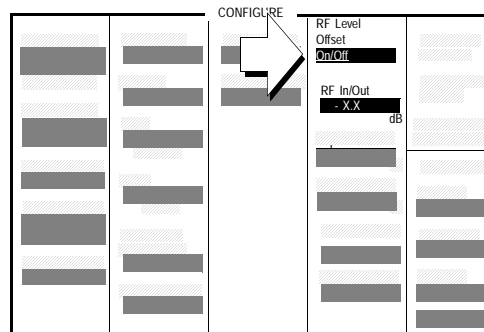

Procedure Overview

Using the RF Level Offset feature of the Test Set corrects for RF path power losses that occur in cabling and connectors between the Test Set and a mobile station.

It is highly recommended that RF path loss is corrected for. Besides returning power measurements that do not have to be adjusted to account for RF path loss, the Test Set uses the values you enter in this procedure to adjust the analyzer path attenuation to an optimum value for demodulation and measurement functions.

NOTE:

The settings you made in this procedure must be re-entered after a power-cycle or instrument preset.

Determining RF Path Loss

The following procedure describes how to use the Test Set to determine path loss.

Procedure Prerequisites

Provide hardware for making a reference measurement.

You must provide a reference cable and the cable adapters necessary to connect the reference cable along with the hardware used to connect the Test Set to the mobile station. Choose a reference cable that has as low of signal loss as possible.

1. Connect a reference cable(s).

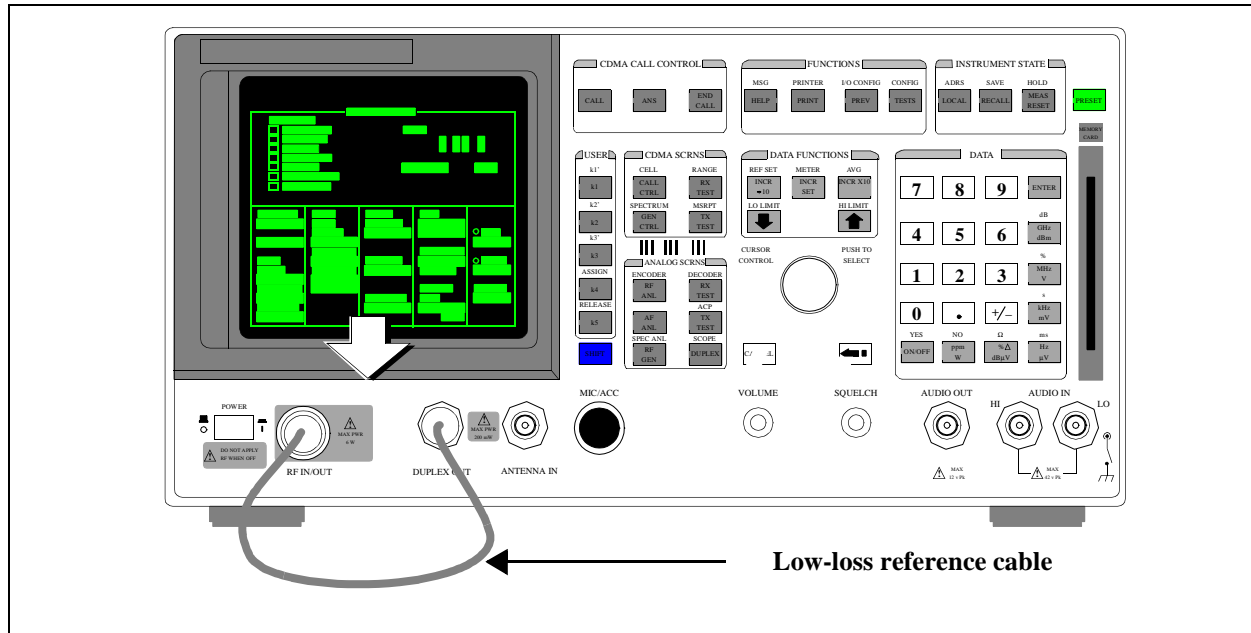

OR...

With
Agilent 83236 PCS INTERFACE

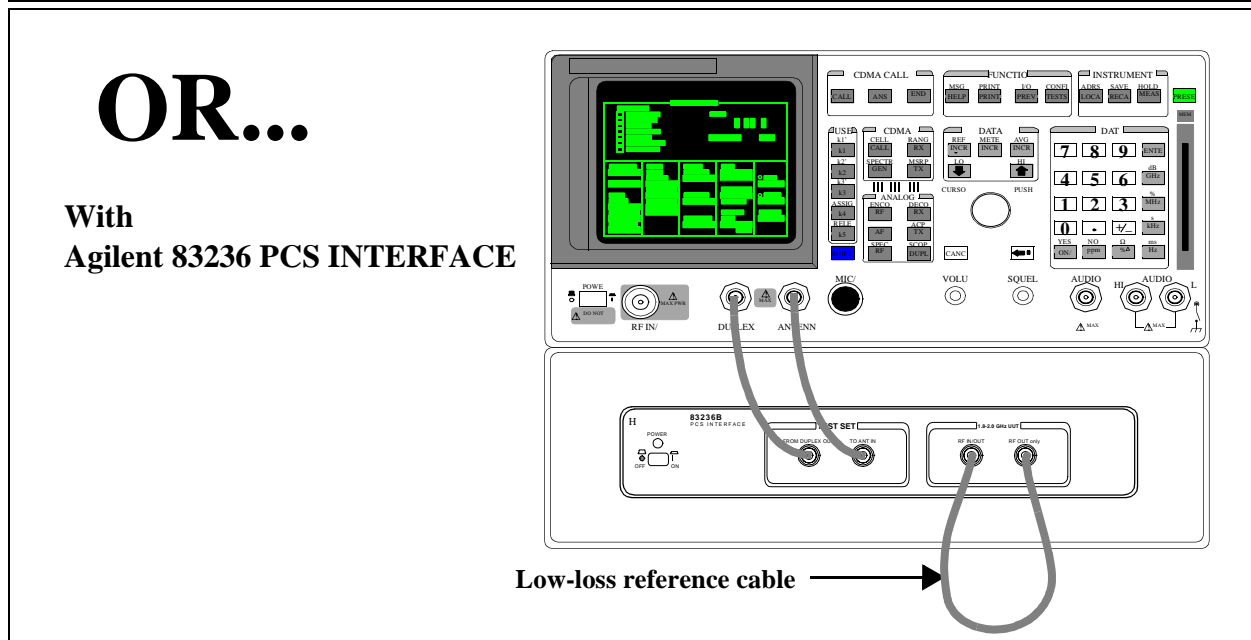

2. Configure the Test Set for RF loopback.

1. Press and release the SHIFT key and then press the TESTS key to display the CONFIGURE screen.

2. Set the Output Port field to Dupl (without PCS Interface) or only (with PCS Interface).

Skip step 3 (below) if a PCS Interface is configured.

3. Set the Input Port field to RF In.

**Test Set
without
PCS
Interface**

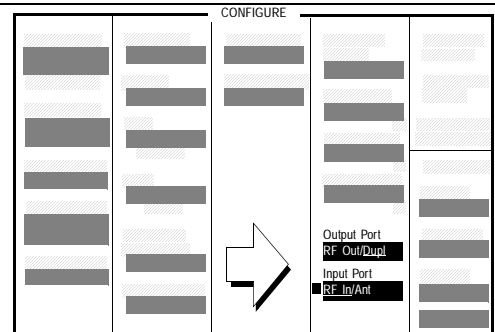

**Test Set
with
PCS
Interface**

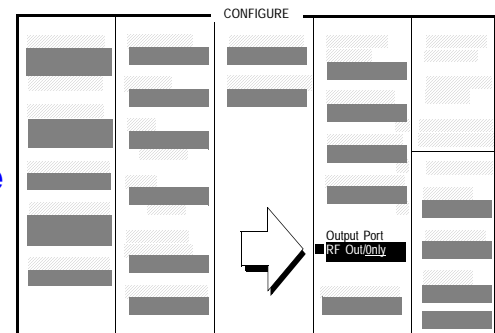

3. Set a 0 dBm reference for the path loss measurement.

1. Press the CDMA SCRNS - TX TEST key to display the CDMA CELLULAR MOBILE TRANSMITTER TEST screen.
2. Select the Sector Power field and set the value to -11.0 dBm/BW with the DATA keys.
3. Select the units-of-measure field and press the knob.
4. Press and release the SHIFT key, then press the INCR + 10 (REF SET) key.
5. Press the knob to set start measurements using the 0 dBm reference.

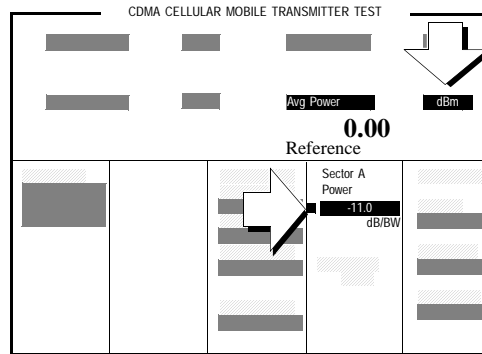

4. Connect the cable and hardware being measured for path loss.

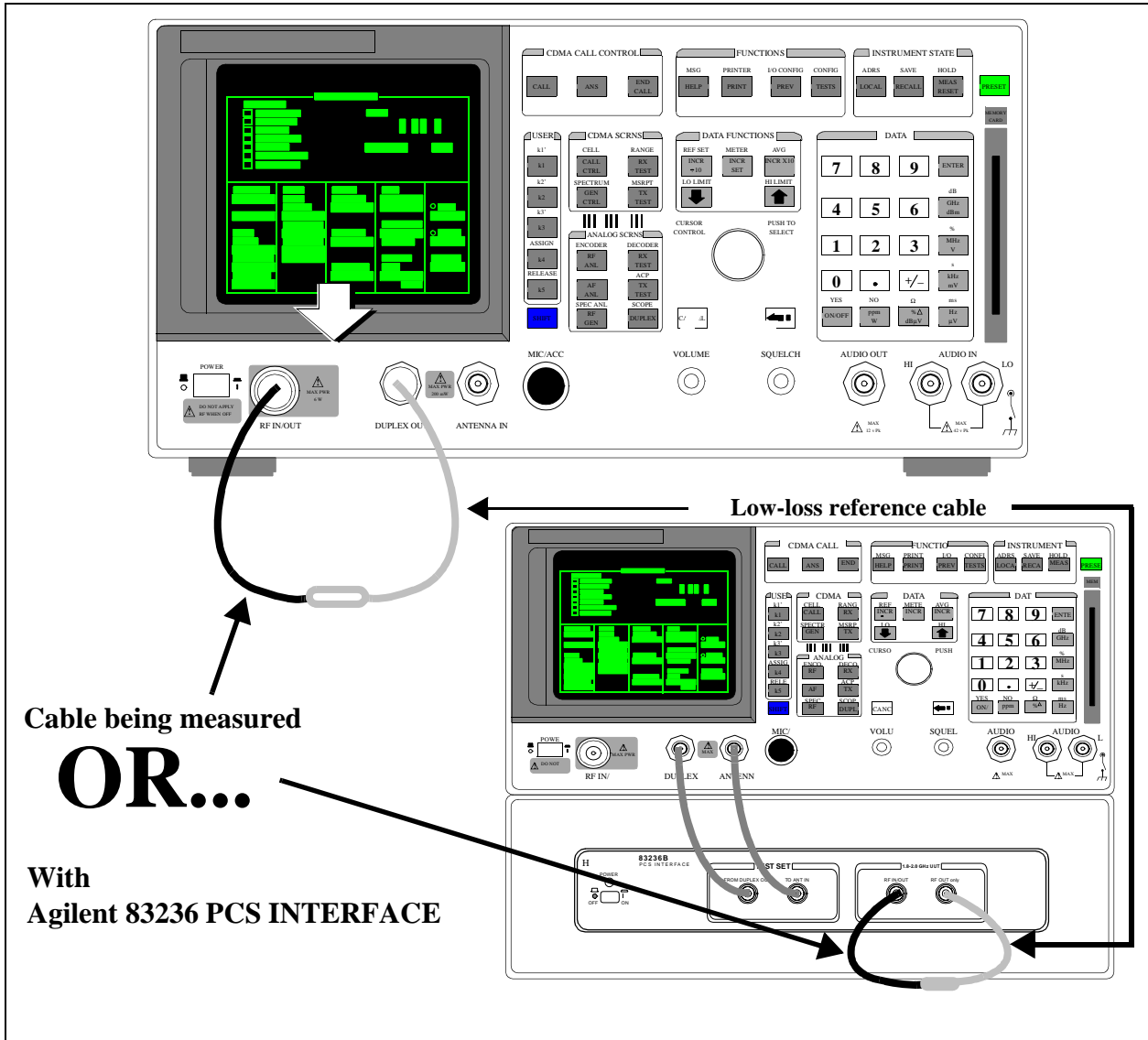

5. Determine the path loss.

Observe the average power measurement reading. This is the measured RF path loss that should be entered in the Test Set's Configure screen.

See **"Correcting for RF Path Loss"** on page 31.

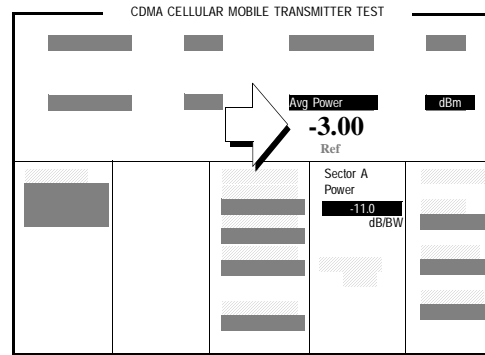

6. Re-configure the Test Set.

Manual Operation:

1. Press the PRESET key

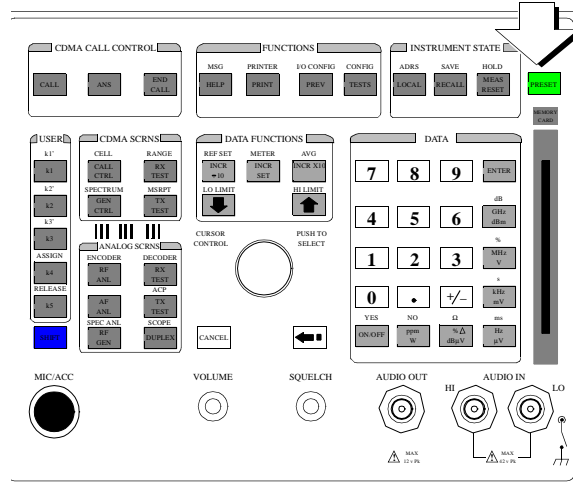

Procedure Overview

The path loss between the Test Set and the Mobile station is measured by first establishing a reference path loss, then including the hardware (cabling, adapters, and that will connect the Test Set to a mobile station during testing.

The path loss value obtained in this procedure is used in "[Correcting for RF Path Loss](#)" on page 31.

Set Up a Call

Setting Up a CDMA Call

When you test a CDMA or dual-mode (CDMA and analog) mobile station you should first attempt to set up a CDMA call. Once a CDMA call is connected, mobile station transmitter power measurements are displayed and many other CDMA measurements are available when by selecting the Test Set's CDMA screens.

If the mobile station has dual-mode capability, the CDMA call can be handed off to analog operation at the press of a knob. With the mobile station operating in analog mode, fundamental audio and RF transceiver measurements are provided on one screen.

NOTE:

If the mobile station being tested is not able to make a call, analog transceiver measurements can be made using the Test Set's general-purpose measurement capability. Refer to the ANALOG MEAS, SPECTRUM ANALYZER (Opt 012 only), and OSCILLOSCOPE screen descriptions in the *Agilent 8924E User's Guide*

Requirements:

Before you start this procedure, make sure you have the following items or information, or meet the following conditions.

- Isolation or shielding apparatus for the mobile station if significant signal interference is present.
- Hardware (cables, adapters, and so forth) to make the RF connection from the Test Set's front-panel type N connector to the mobile station (cabling should be as low-loss as possible).
- Knowledge of the CDMA RF channel that mobile station is programmed to find service on.
- Knowledge of the CDMA protocol and RF channel standard used by mobile station.
- A power supply with dc-power cabling to the mobile station or a battery that has sufficient charge to power the mobile station for the duration of testing.
- (Optional) If you want to make analog audio measurements, a way to make audio connections (microphone and ear) from the mobile station to the Test Set's audio BNC front-panel connectors.

NOTE:

Mobile stations operating in the PCS frequency band (1900 MHz) can be tested only on Agilent 8924E Test Set's that are configured with the Agilent 83236 PCS Interface. This interface attaches to the bottom of the Agilent 8924E inside of a "shell" called the Bench Top Kit.

Setting up a Call

1. Preset the Test Set.

1. If the Test Set is not powered on:
 - a. Turn on power to the PCS Interface (if one is present), then...
 - b. Turn on power to the Test Set. Wait for the Test Set to complete its power-up routine
2. Press the PRESET key (to begin this procedure in a known state).

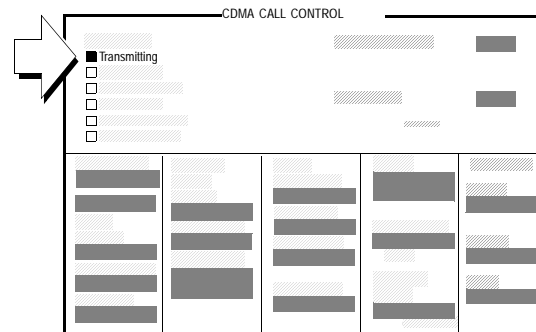

Pressing the PRESET key will configure the Test Set using factory default settings, and display the CDMA CALL CONTROL screen.

If you have the Test Set configured to operate with a PCS Interface, and you do not turn PCS Interface power on before the Test Set, the message “PCS Interface not found. Check power, cabling or CONFIG.” will be displayed. To correct this condition, follow the correct sequence of powering up these two units.

2. Enter the CDMA Protocol and RF Channel Standard.

1. Press the CDMA SCRNS - CALL CTRL key to display the CDMA CALL CONTROL screen.
2. Select the Protocol field.
3. Select a protocol from the list of choices.
4. Select the RF Chan Std field.
5. Select one of the standards from the list of choices.

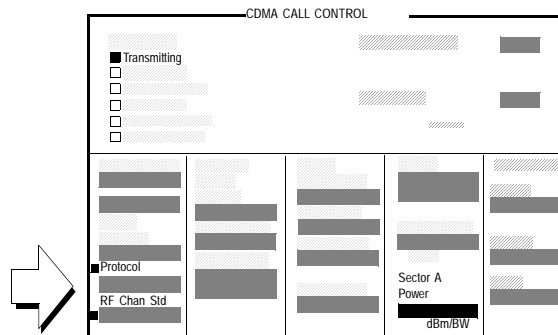

The list of RF Chan Std choices includes only those supported by the hardware configuration. Some RF channel standards require the Agilent 83236B with Option 007 (Wideband). Refer to the [RF Chan Std](#) field description in the Agilent 8924C User's Guide.

3. Enter the Mobile Station's CDMA RF Channel number.

1. Select the RF Channel field.
2. Enter the CDMA RF channel number that your mobile station is assigned to. Tip: Use the DATA keys.
3. Press the ENTER key or the knob to enter the value.

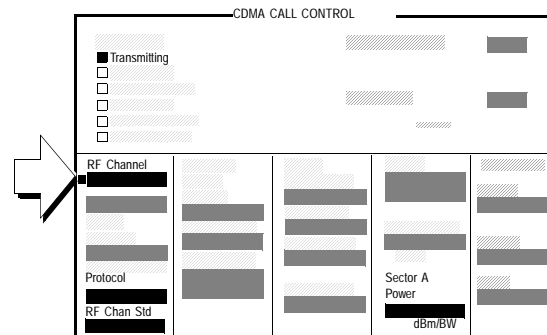

The mobile station's primary CDMA channel depends on its preferred serving system (System A or System B) and Protocol. Listed below are the primary CDMA channel numbers specified in EIA/TIA IS-95.
System A Primary CDMA Channel: 283.
System B Primary CDMA Channel: 384.

4. Enter the Mobile Station's preferred system (SID).

1. Press then release the blue SHIFT key, then press the CDMA SCRNS - CALL CTRL key to select the CDMA CELL SITE CONFIGURATION screen.
2. Select the System ID field.
3. Enter the mobile station's preferred system identification.
4. Press the PREV key to return to the CDMA CALL CONTROL screen.

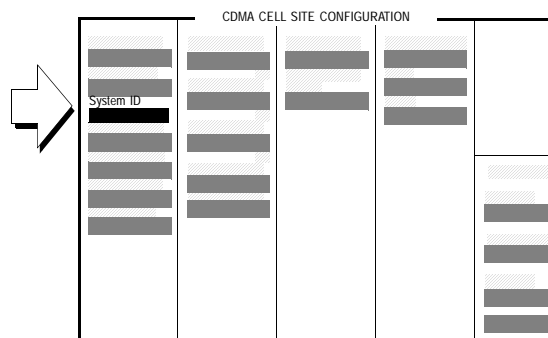

System ID is programmed into the mobile station by the service providers. When power is turned on, the mobile station searches for CDMA signals. When the CDMA signal is demodulated, the mobile station finds out whether or not the Test Set's system matches the system it is programmed to prefer service on.

Depending on how the mobile station is programmed, entering an incorrect number in this field could cause the mobile station to delay any call-processing until it has exhausted a search of other RF channels, or it may not allow any calls at all.

5. Make the RF connection between the Test Set and the mobile station.

Make sure all connections to the mobile station, including dc power, are made.

Some mobile station's do not have an RF connection. In these cases, the manufacturer will usually make a fixture, such as a car adapter, that will provide an RF cable connection. The mobile station snaps into the fixture and an RF connection is made through an electromagnetic coupler near the mobile station's antenna.

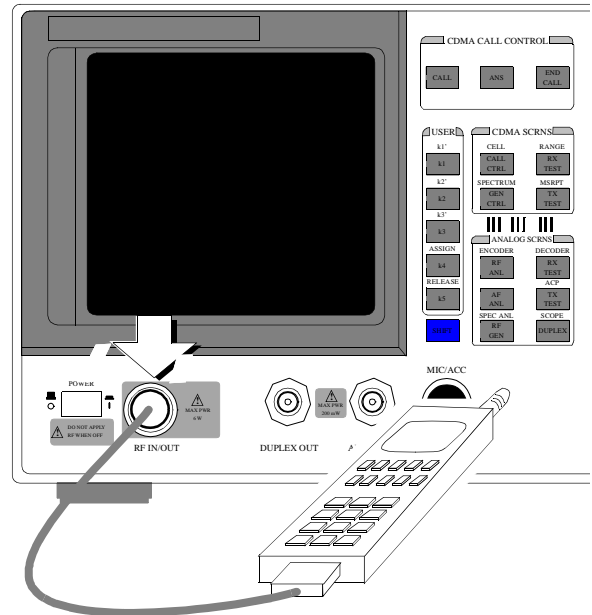

OR...

With Agilent 83236 PCS INTERFACE

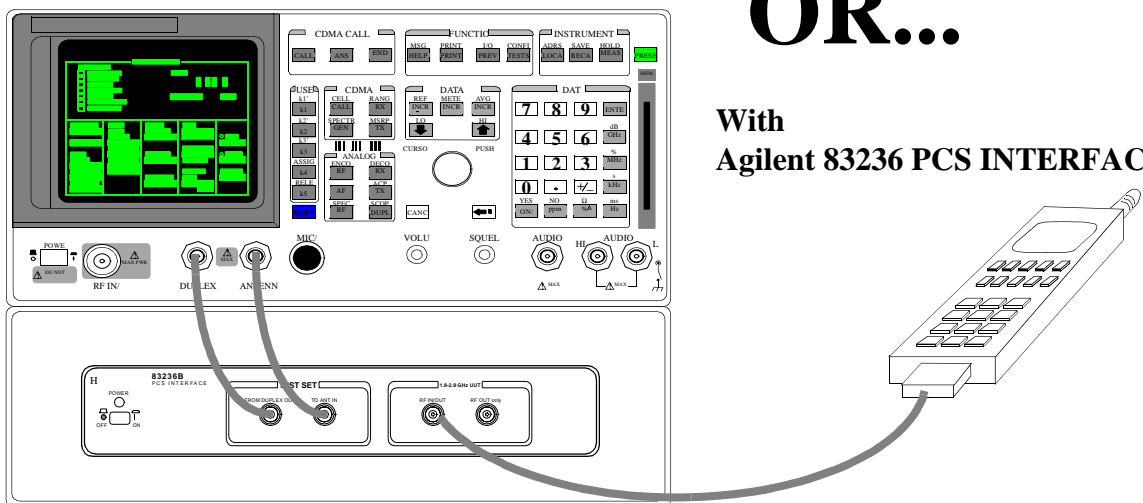

6. Turn on power to the mobile station.

Wait until the mobile station has found *digital* (CDMA) service (this should take no longer than about 30 seconds).

If the mobile station does not find digital service, refer to the "[Problem Solving Checklist](#)" on page 52.

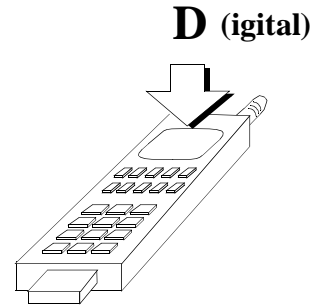

Most mobile stations have a NO SERVICE annunciator that will go out when the mobile station has found service. Other mobile stations use an LED that indicates when service has been found.

If a strong signal from an analog base station is present, or the mobile station is programmed to prefer analog service, the mobile station may not find digital service. If this condition exists, re-program the phone, or isolate it from the competing analog signal using an RF isolation chamber.

Caution: *Do not exceed 6 W continuous power into the Test Set's RF IN/OUT connector with any transmitter.*

7. Dial 1234 on the mobile station's handset, then press SEND.

You can use practically any sequence of numbers to perform this step. 1,2,3 was chosen simply for convenience.

The Test Set's Access Probe annunciator will light, indicating that the mobile station sent an access probe sequence, then the Connected annunciator will light.

After a mobile station has successfully originated a call, you will see the mobile station's identification displayed in the MS Database field.

Another way to retrieve MS Database data from the mobile station is by selecting the Register field before a call is connected.

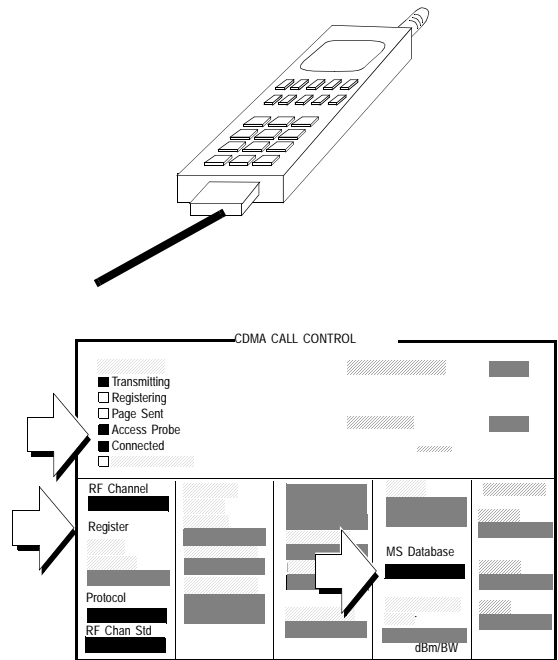

Note: When the MS Database field displays the current mobile station's identification, a call can be originated from the Test Set by pressing the CALL key.

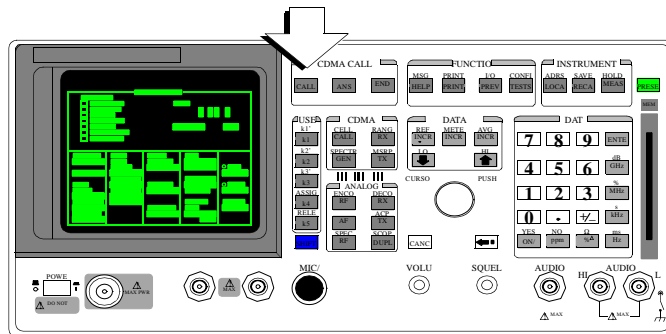

8. Speak into the mobile station's microphone.

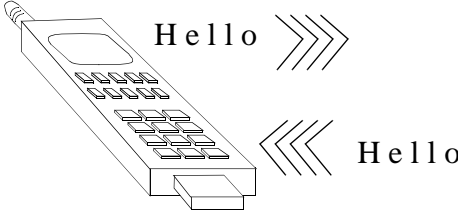
<p>Your voice will be echoed back with a 2 second delay.</p>	 <p>The diagram shows a mobile phone with the word "Hello" and three right-pointing chevrons to its right, representing voice input into the microphone. Below the phone, the word "Hello" and three left-pointing chevrons are shown, representing the voice being output from the earpiece.</p>
<p><i>This test is referred to as “Voice Echo” and is performed with the mobile station connected on a Service Option 1 or Service Option 32768 call.</i></p> <p><i>Voice Echo is a subjective test of the mobile station’s ability to encode your voice, modulate the carrier with the information data representing your voice, and demodulate/decode the same voice information, then outputting an audio reproduction of you voice on the earpiece of the mobile station.</i></p>	

Procedure Overview

Many mobile station tests performed by the Test Set require that a call be connected. To set up a call, the Test Set must be configured to include:

- The mobile station's CDMA RF Channel
- The mobile station's Protocol
- The mobile station's RF Channel Standard
- The mobile station's system identification (unless mobile station roams).

The steps beginning on page 42 describe how to make a mobile station originated call (by dialing numbers on the mobile station). The mobile station registers as the call is being connected, but there are other circumstances that can cause mobile station registration. They are:

- Power-up registration (usually initiated when mobile station is turned on) and
- Zone-based registration (initiated by selecting the field labeled **Register**)

Regardless of which event causes the mobile station to register, the field labeled **MS Database** displays the mobile station's identification. As soon as you see this field updated, you have the option of making a base station originated call by pressing the CALL key on the Test Set's front panel.

Problem Solving Checklist

If the mobile station does not find service, does not register, or does not connect when a number is dialed on it, check the following items:

- Is the RF cable connected?*
- Is the RF Channel number correct? (Set the RF Channel on the CDMA Call Control screen.)*
- Is Sector A Power adequate? If interference from other cellular band signals is present, Sector A Power may need to be set to a level greater than the instrument's preset value of -75 dBm/BW. (Set Sector A Power on the CDMA Call Control screen.) Example: If the mobile station is finding analog service, adjust Sector A Power to -30 dBm/BW, then cycle power on the mobile station. Isolating the mobile station may be necessary.*
- Is the AWGN generator (CDMA Gen Control screen) off?*
- Is the mobile station programmed to roam? If not, set the System ID on the CDMA Cell Site Configuration screen, then cycle power on the phone.*
- Are the entries in the Rgstr SID and Rgstr NID fields valid entries for the mobile station? (The Rgstr SID and Rgstr NID field entries, found on the CDMA Cell Site Configuration screen, must be recognized as a valid SID/NID pair by the mobile station).*
- Are the entries in the Rgstr SID and Rgstr NID fields different than the mobile station's Home SID/NID? (The Rgstr SID and Rgstr NID fields, found on the CDMA Cell Site Configuration screen, must be different than the mobile station's Home SID/NID).*
- Is the power supply providing adequate current? (Make sure the mobile station's power supply duplicates the voltage, impedance, and ampere hours of the manufacturer's recommended power supply).*

Mobile Station CDMA Tests

List of CDMA Tests

NOTE:

To perform the following tests, a CDMA call must be set up. See "[Setting Up a CDMA Call](#)" on page 42.

["Rho \(Transmitter Waveform Quality\)"](#) on page 55.

["Minimum/Maximum Transmitter Power"](#) on page 57.

["FER \(Frame Error Rate\)"](#) on page 59.

["Measuring Access Probe Output Power"](#) on page 65.

["Performing a CDMA-to-CDMA Interband Handoff"](#) on page 70.

Rho (Transmitter Waveform Quality)

1. Arm the Rho measurement.

1. Press the CDMA SCRNS - TX TEST key to display the CDMA CELLULAR MOBILE TRANSMITTER TEST screen.
2. Select Arm to arm the Rho measurement.

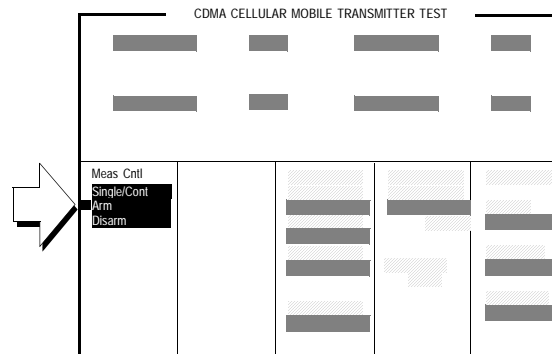

The default measurement trigger mode is Single. If Cont is selected, the Arm and Disarm fields are removed from the display and Rho measurements will trigger continuously.

2. Measure Rho.

- Rho (Traffic Rho) must be above 0.944 to meet minimum standards.
- If you select the Freq Error field, you can display the Amplitude Error and Time Offset measurements.
- Also, if you select the Phs Error field you can display the Carrier (Feedthrough) measurement.

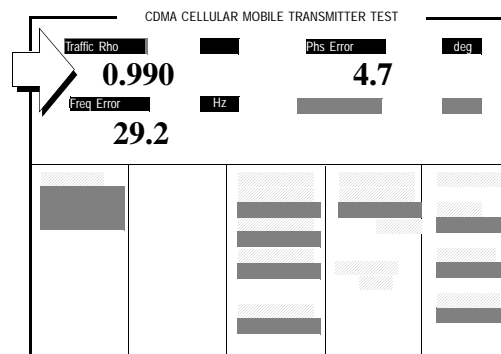

Time Offset must be within $\pm 1 \mu\text{s}$ to meet minimum standards.
Frequency Error must be within $\pm 300 \text{ Hz}$ to meet minimum standards.

Measurement Overview

The value you obtained during the Rho measurement is based on a comparison, or *cross-correlation*, of the actual transmitted signal to the ideal signal transmitting the same data. *Rho* represents the percentage of power in the transmitted signal that correlates with the ideal signal.

Rho measurements give you a very comprehensive indication of transmitter performance. If there are significant problems with the mobile station's output power amplifier, I/Q modulator, or filters there is a good chance they will cause degradation in the Rho measurement value.

When a Rho measurement is made, the following measurements are also made:

- Frequency Error (see [table 1](#)).
- Phase Error (excessive values may be due to filter ripple, I/Q modulator quadrature errors, or distortion or compression in output power amplifier).
- Amplitude Error (excessive values may indicate distortion or compression in output power amplifier).
- Time Offset (see [table 1](#)).
- Carrier Feedthrough (values higher than -25 dB indicate excessive I/Q modulator DC offsets)
- Average Power and Channel Power

[Table 1](#) lists some typical test standards:

Table 1 **Waveform Quality**

Rho	>0.944 (94.4%)
Frequency Error	± 300 Hz
Time Offset	± 1 us

Minimum/Maximum Transmitter Power

1. Start a Min/Max Power measurement.

1. Press then release the blue SHIFT key, then the CDMA SCRNS - RX TEST (RANGE) key to select the CDMA TRANSMITTER CLOSED LOOP RANGE TEST screen.
2. Select Execute to begin the Min/Max Power test.

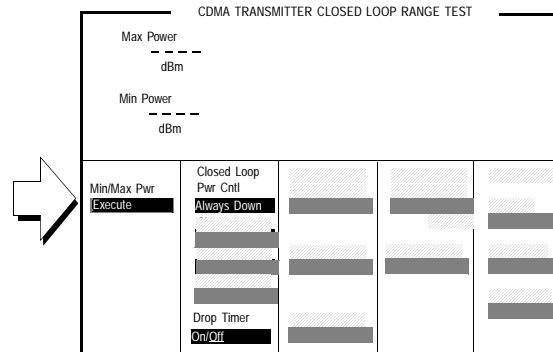

2. Check Min/Max power test results.

1. Wait a few seconds for this test to complete.
- Min Power will be displayed first, followed by Max Power.

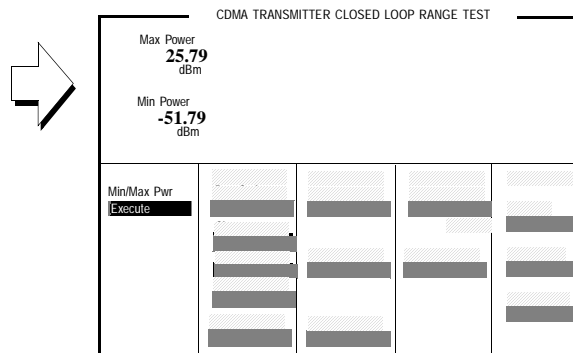

Measurement Overview

The Min/Max Pwr field provides a quick way to determine a mobile station's minimum power and maximum power using both open loop and closed loop power control.

Table 2 and **Table 3** list typical standard test values:

Table 2 Maximum Output Power

Mobile Station Class	Lower Limit	Upper Limit
I	1 dBW (1.25 watts)	8 dBW (6.3 watts)
II	-3 dBW (0.5 watts)	4 dBW (2.5 watts)
III	-7 dBW (0.2 watts)	0 dBW (1.0 watts)

Table 3 Minimum Output Power

Mobile Station Class	Lower Limit
All classes	-50 dBm/1.23 MHz

FER (Frame Error Rate)

1. Select Service Option 2 or 9.

1. Press the CDMA SCRNS - RX TEST key to display the CDMA CELLULAR MOBILE RECEIVER TEST screen.
 2. Set the Traffic Data Mode field to Svc Opt 2 (Rate Set 1) or Svc Opt 9 (Rate Set 2).
- The Svc Opt 2/9 annunciator should now be lit.

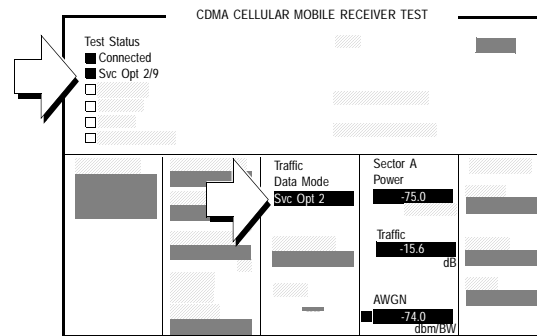

The Connected annunciator and the Svc Opt 2/9 annunciator must be lit to perform FER testing.

Rate (or Rate Set) 1 refers to a mobile station with a vocoder that operates (full rate) at 9600 bps.

Rate (or Rate Set) 2 refers to a mobile station with a vocoder that operates (full rate) at 14400 bps.

2. Set the noise level (AWGN).

1. Position the cursor at the AWGN field.
2. Press the ON/OFF key.
3. Adjust AWGN so that it is 1 dB higher in power than the Sector Power setting.

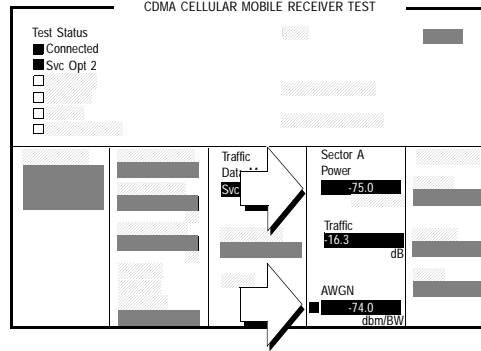

AWGN determines the signal-to-noise ratio of the forward CDMA channel.

Test standards refer to the ratio of Sector Power to AWGN as I_{or}/I_{oc} , and specify a ratio of -1 for all these tests.

3. Verify E_b/N_t reading.

E_b/N_t should be 4.47 if the Traffic field is set to its default value of -15.6 and the Data Rate field is set to Full.

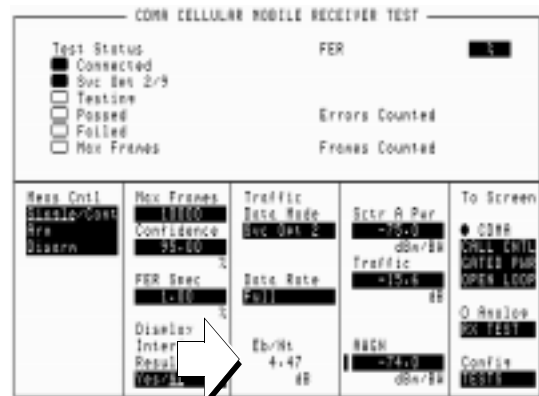

Procedures found in the CDMA mobile station test standards will instruct you to vary E_b/N_t by changing Traffic E_c/I_{or} (Traffic field) and Data Rate field settings, then perform FER tests at each setting.

4. Enable display of FER interim test results.

1. Set the Display Interim Results field to Yes.

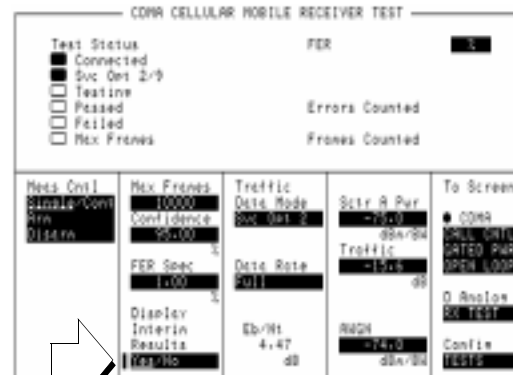

5. Arm a single FER measurement.

Manual Operation:

- Select Arm to begin FER testing.

Interim FER test results should appear on the display, with the Frames Counted field incrementing.

If interim FER test results do not appear, press the END CALL key, then press the CALL key to re-establish a Svc Opt 2 or 9 call.

The screenshot shows the 'CDMA CELLULAR MOBILE RECEIVER TEST' interface. At the top, it displays 'FER 0.00', 'Errors Counted 0', and 'Frames Counted 122'. Below this, there are several data fields: 'Max Frames 10000', 'Confidence 95.00', 'FER Spec 1.00', 'Display Interim Results Yes/No', 'Traffic Data Mode Svc Opt 2', 'Data Rate Full', 'Eb/Nt 4.47 dB', 'Sector A Power -75.0 dBm/BW', 'Traffic -16.3 dB', and 'AWGN -74.0 dBm/BW'. A 'Test Status' section on the left shows 'Connected' and 'Svc Opt 2/9' as active, with 'Testing' also indicated. Two white arrows point to the 'Testing' status and the 'FER' value.

Most mobile stations support service option negotiation while on a call. If your phone does not, the FER display will be four dashes, indicating no measurement results are available. Setting up a call with Service Option 2 or 9 selected will correct this problem

When a measurement is running, the Testing annunciator will be lit.

6. Check for a passed or failed indication.

When the Testing annunciator goes out, one of the following three annunciators will light:

Passed
 Failed
 Max Frames

The screenshot shows the 'CDMA CELLULAR MOBILE RECEIVER TEST' interface. The 'Testing' status is active. Parameters shown include 'Max Frames 10000', 'Confidence 95.00', 'FER Spec 3.00', 'Display Interim Results Yes/No', 'Traffic Data Mode Svc Opt 2', 'Data Rate Full', 'Eb/Nt 3.77', 'Sector A Power -75.0 dBm/BW', 'Traffic -16.3 dB', and 'AWGN -74.0 dBm/BW'. A white arrow points to the 'Testing' status.

FER testing will typically end before the Max Frames number of frames has been tested. This is because the Test Set limits testing to the number of frames required to achieve a 95% confidence level the test will pass (or fail).

The FER Spec field specifies the criteria for determining whether a mobile station passes or fails FER testing.

Test standards require better FER performance as E_b/N_t (signal-to-noise) is increased.

7. Change Traffic Data Rate to Half.

1. Set the Data Rate field to Half.
2. Set the Traffic field to -18.6 dB (reducing power by one-half).

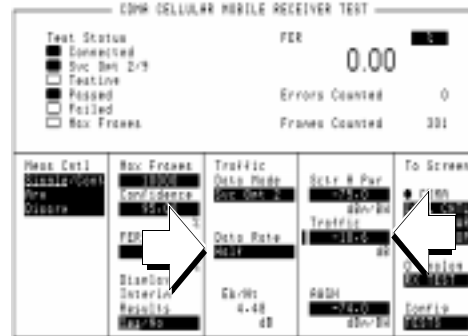

Changing Data Rate to "Half" increased E_b/N_t by 3 dB. Here's why: To transmit half-rate data, a CDMA base station transmits each information bit two times. This doubles the energy per bit, E_b . To offset this 2X increase in E_b/N_t , the Traffic channel is lowered by 3 dB.

Whenever the data rate is lowered, the test standards will always specify a lower Traffic channel level to maintain E_b/N_t levels that will adequately test the sensitivity of the mobile station.

8. Arm another FER measurement.

1. Select the Arm field to begin another FER test.



Measurement Overview

During this test, FER is measured with the AWGN (Additive White Gaussian Noise) generator turned on. The relative settings of AWGN, Sector Power, and Traffic, along with Data Rate provide a value called E_b/N_t , which is analogous to signal-to-noise ratio in analog radio test.

Test standards require FER testing at various levels of E_b/N_t , which are adjusted using the Data Rate and Traffic fields. The value you enter in the FER Spec field provides Pass/Fail criteria for the test, which will be more stringent at higher values of E_b/N_t .

Because the Test Set supports the Confidence Interval ¹ procedure for testing FER, the number of frames tested will typically be far less than the number of frames entered in the Max Frames field. This speeds up FER tests dramatically.

This test is fully described in "Demodulation of Forward Traffic Channel in Additive White Gaussian Noise," found in standards such as *TIA/EIA/IS-98-A* or *J-STD-018*.

1. Refer to Appendix A in the appropriate test standard for a description of Confidence Interval testing.

Measuring Access Probe Output Power

There are two methods available for measuring access probe power with the Test Set:

- Use a Spectrum Analyzer.

When using a spectrum analyzer, which allows each individual access probe to be measured, the Test Set provides call setup only while the spectrum analyzer performs measurements. The Test Set has to be put in a mode that limits the progression of call processing states (by setting the **Call Limit** field to Page), allowing the MSUT to transmit the maximum number of access probe sequences.

- Select the Acc Prb Pwr field as described in the following procedure.

Access probe power can be measured by the Test Set during registration, call setup, or when SMS or Authentication testing is performed on paging channels. This method requires no additional equipment or setup procedures beyond what is required for channel power measurements. Refer to the *User's Guide*, Description of Fields chapter, for a complete description of the Acc Prb Pwr field.

1. Make sure there is no call connected.

Manual Operation:

1. Press the CDMA SCRNS CALL CTRL key to display the CDMA CALL CONTROL screen.
2. If the Connected annunciator is lit, press the END CALL key on the Test Set's front panel.

The Connected annunciator should be extinguished.



2. Set the test parameter \hat{I}_{or} .

- Manual Operation:**
1. Position the cursor at the Sctr A Pwr field.
 2. Enter -75.0 with the DATA keys. (Refer to the applicable standard for test parameters).
 3. Press the ENTER key or the knob to enter the value.

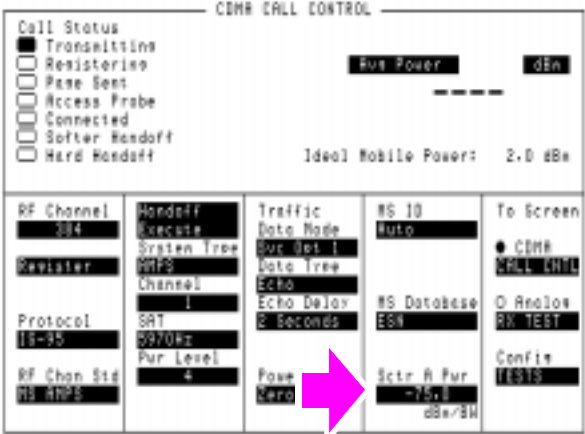

3. Select the Access Probe Power measurement.

Manual Operation:

1. Position the cursor at the field shown to the right.
 2. Press the knob to display a list of choices.
 3. Select Acc Prb Pwr and press the knob.
- Acc Prb Pwr should be displayed in the field.

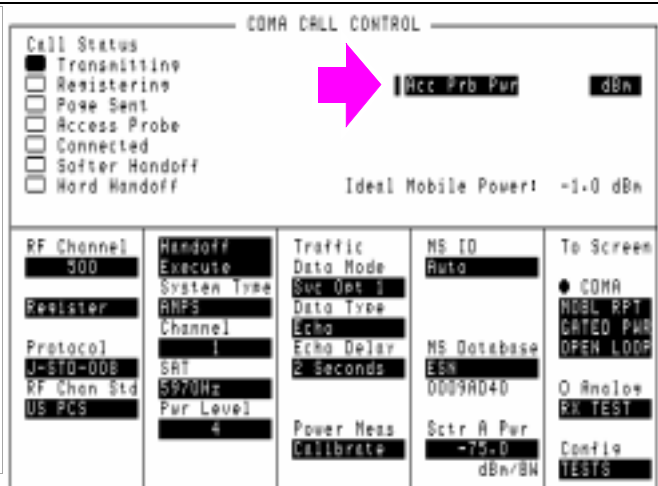

4. Send access probes to the Test Set.

Manual Operation:

1. Press the CALL key on the Test Set's front panel.

The access probe power measurement will be displayed below the field.

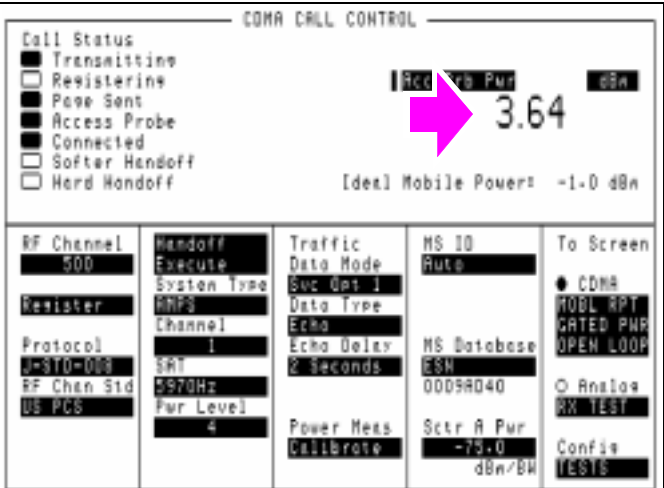

The Acc Prb Pwr field, located on the CDMA CALL CONTROL, CDMA CELLULAR MOBILE TRANSMITTER TEST, and CDMA TRANSMITTER POWER RANGE TEST screens, automatically senses when the mobile station power level crosses a threshold (approximately -55 dBm/BW) and measures access probe power during each sequence. When an access attempt has completed, the last access probe power measurement is displayed.

Performing a CDMA-to-CDMA Interband Handoff

The Test Set has the capability to perform a handoff from a CDMA traffic channel to another CDMA traffic channel of a different band class. The following conditions are required for a successful handoff:

- TIA/EIA-95B must be selected in the Protocol field (requires firmware A.02.03 or above)
- The mobile station must have dual-band capability.
- A call must be set up (see "[Setting Up a CDMA Call](#)" on page 42).

1. Select TIA/EIA-95B for the hard handoff destination system.

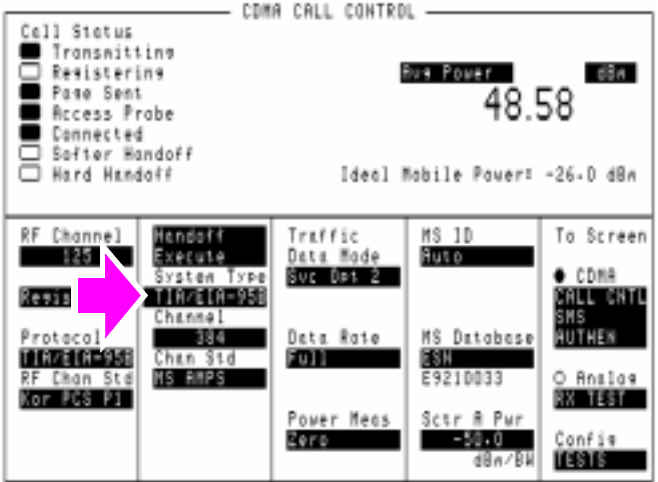
<p>Manual Operation:</p> <ol style="list-style-type: none">1. Position the cursor next to the System Type field as shown in the figure.2. Select TIA/EIA-95B. <p>Note: TIA/EIA-95B must be selected in the Protocol field before TIA/EIA-95B is available as a choice in the System Type field.</p>	 <p>The screenshot shows the 'CDMA CALL CONTROL' menu with various status indicators and fields. The 'System Type' field is highlighted with a pink arrow pointing to 'TIA/EIA-95B'. Other fields include 'RF Channel' (125), 'Handoff' (Execute), 'Traffic Data Mode' (Svc Det 2), 'MS ID' (Auto), and 'To Screen' (CDMA CALL CTRL, SMS AUTHEN, Analog RX TEST, Config TESTS). The 'Avrg Power' is 48.58 dBm and 'Ideal Mobile Power' is -26.0 dBm.</p>
---	--

2. Select the hard handoff destination channel standard.

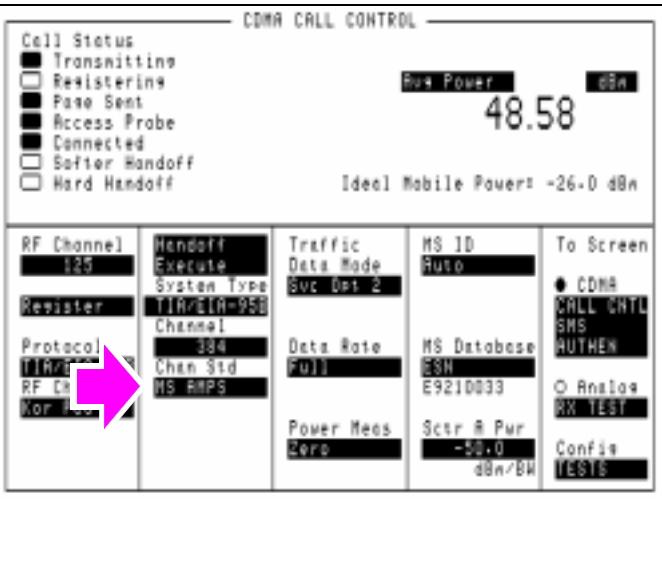
<p>Manual Operation:</p> <ol style="list-style-type: none">1. Position the cursor next to the Chan Std field.2. Select a channel standard.	 <p>The screenshot shows the 'CDMA CALL CONTROL' screen. At the top, 'Call Status' is displayed with several indicators: Transmitting (checked), Registering (unchecked), Page Sent (checked), Access Probe (checked), Connected (checked), Softer Handoff (unchecked), and Hard Handoff (unchecked). The 'Rx Power' is 48.58 dBm and 'Ideal Mobile Power' is -26.0 dBm. The screen is divided into several sections: 'RF Channel' (125), 'Handoff Execute' (checked), 'Traffic Data Mode' (Svc Det 2), 'MS ID' (Auto), and 'To Screen' (CDMA, CALL CTRL, SMS, AUTHEN). Below these are 'Register' (TIA/EIA-950), 'Protocol' (IS-63), 'Chan Std' (IS-AMPS), 'Data Rate' (Full), 'MS Database' (ESN, E9210033), and 'Power Meas' (Zero). A pink arrow points to the 'Chan Std' field.</p>
--	---

3. Select the hard handoff destination channel number.

Manual Operation:

1. Position the cursor next to the Channel field.
2. Select a channel number.

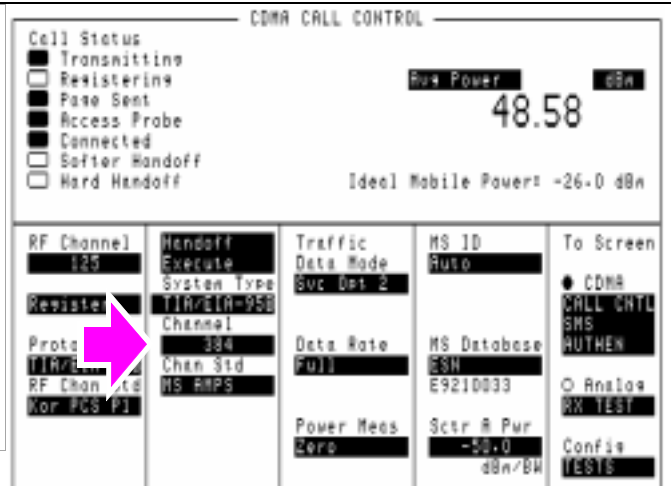

4. Execute a CDMA-to-CDMA hard handoff.

Manual Operation:

1. Position the cursor next to the Execute field.
2. Press the knob to initiate a hard handoff.

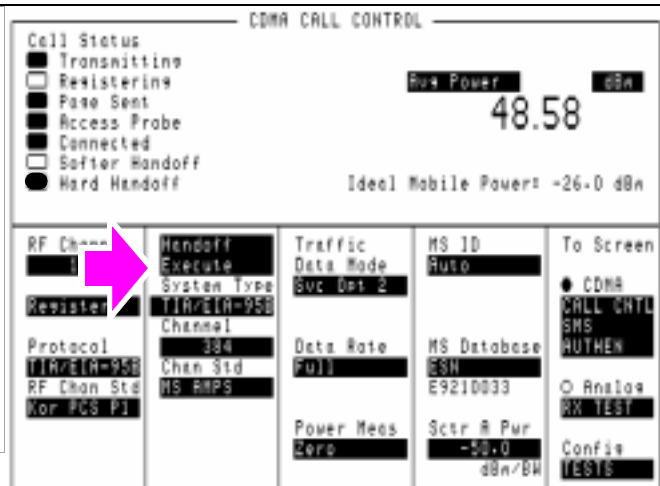

When a hard handoff is executed the Hard Handoff annunciator will light.

If the hard handoff is successful the Hard Handoff annunciator will be extinguished.

If the hard handoff is not successful the Hard Handoff annunciator will be extinguished and an error message will be displayed. The state of the test set's base station simulation will remain the same as before the hard handoff attempt.

Example:

"Mobile reject order received" will be displayed if the mobile station rejects the (extended) handoff direction message.

Mobile Station Analog Tests

List of Analog Tests

NOTE:

To perform the following tests, a CDMA call must be set up. See "[Setting Up a CDMA Call](#)" on page 42.

- "[Performing a CDMA to Analog Handoff](#)" on page 77
- "[Performing an Analog Call](#)" on page 81
- "[Transmitter Measurements \(no audio connections required\)](#)" on page 85
- "[Receiver Audio Distortion and Hum and Noise \(requires audio connections\)](#)" on page 88
- "[Transmitter Audio Distortion and Hum and Noise \(requires audio connections\)](#)" on page 93

Performing a CDMA to Analog Handoff

The Agilent 8924E has the capability to simulate both a CDMA cell site and an analog cell site. This makes it possible to perform a handoff from a CDMA traffic channel to an analog voice channel. This type of handoff allows you to easily change from CDMA testing to analog testing.

The following conditions are required for a successful handoff:

- You must know the mobile station's system type (AMPS, NAMPS).
- A CDMA call must be connected.
- The mobile station must be programmed to allow analog operation.

For some of the following analog tests, you will need audio connections from the mobile station's microphone and earpiece to the Test Set's AUDIO OUT and AUDIO IN, respectively.

1. Select an analog system for handoffs.

1. Select the CDMA CALL CONTROL screen.
2. Set the System Type field to your mobile station's analog system type.

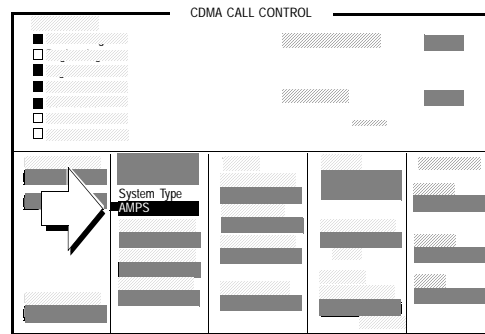

2. Set up handoff parameters. (Optional)

1. Set the Channel, SAT, DSAT, or Pwr Level fields as needed to specify handoff parameters.

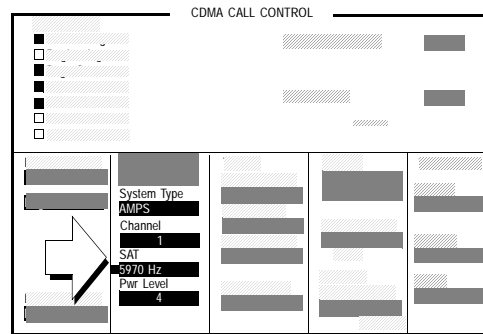

These three fields provide the Test Set with information about how to set up the simulated analog cell site for the handoff to an analog voice channel. The three fields are:

- **Channel:** *The analog voice channel that will be allocated for CDMA to analog handoffs.*
- **SAT:** *The supervisory audio tone that the Test Set will transmit, and the mobile station will transpond.*
- **Pwr Level:** *The power level to be transmitted by the mobile station after the handoff is successful, referred to as VMAC (voice mobile attenuation code).*

3. Execute the CDMA to analog handoff.

1. Select Execute.

The Access annunciator should light for a few seconds, then the Connect annunciator will light, indicating the handoff is successful.



When a CDMA to analog handoff is attempted, the Test Set reconfigures itself as an analog cell site, and displays the CALL CONTROL screen. This is the screen that controls analog call processing.

Problem Solving

- ❑ In some cases, background noise can inhibit supervisory audio tone (SAT) detection during call setup. If the mobile station does not provide a way to mute the microphone, set the **Sat Tol** field to **Wide** on the **CALL CONFIGURE** screen. Then, attempt the handoff again.

Procedure Overview

The CDMA to Analog handoff is performed by selecting the **Execute** field on the **CDMA CALL CONTROL** screen when a CDMA call is connected. The Test Set reconfigures itself as an analog cell site and hands the mobile station off to a voice channel on the system type specified.

Performing an Analog Call

This procedure is optional. If you would like to skip this procedure and begin testing now, turn to "[Transmitter Measurements \(no audio connections required\)](#)" on page 85.

The same general conditions for performing a CDMA call also apply to performing an analog call. See "[Problem Solving Checklist](#)" in chapter 2 if the call does not connect.

1. Enter the mobile station's control channel number.

1. Set the Cntrl Chan field to one of the control channel numbers that the mobile station is programmed to find service on.

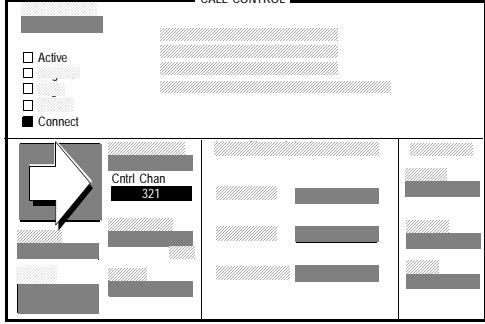

The screenshot shows a 'CALL CONTROL' window with a list of control channels. The 'Cntrl Chan' field is highlighted with a white arrow pointing to the value '321'. The 'Active' checkbox is checked, and the 'Connect' checkbox is unchecked.

When attempting to acquire analog service, the mobile station receiver scans its “preferred system” control channels when it is turned on, or when a call is released. By decoding the data on the control channel, the mobile station can determine the cellular system I.D. and determine if it is roaming.

In North American FM systems, System A control channels are 313-333, and System B control channels are 334-354.

2. End the current call (if the Connected annunciator is lit).

1. Select Release.

The Active annunciator should now be lit.

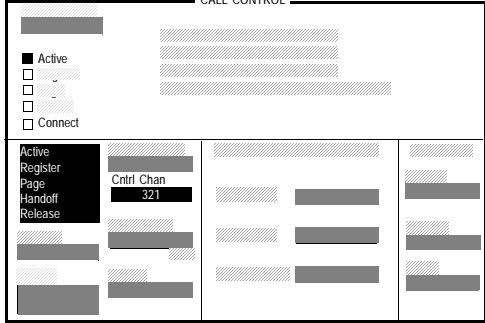

The screenshot shows the 'CALL CONTROL' window with the 'Release' option selected in the left-hand menu. The 'Active' checkbox is checked, and the 'Connect' checkbox is unchecked. A white arrow points to the 'Release' option.

*The mobile station receiver will scan its “preferred system” control channels when the call is released (or power is turned on). It should lock to the Test Set's control channel and continue to display that it has service. If the mobile station loses service, increase the Amplitude field setting to -30 dBm, and cycle power to the mobile station. If this doesn't work, refer to **"Problem Solving Checklist"** in chapter 2*

3. Dial 1234 on the mobile station's handset, then press SEND.

You can use any sequence of numbers to perform this step.
1,2,3,4 was chosen simply for convenience.

The Test Set's Access annunciator will light, then the Connect annunciator will light.

After a mobile station has successfully originated a call, you will see the mobile station's identification displayed on the CALL CONTROL screen (if Data is selected in the Display field).

Another way to retrieve the mobile station identification is by selecting the Register field when the Active annunciator is lit.

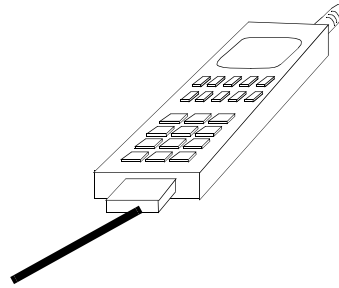

4. End the current call.

1. Select Release.

The Active annunciator should now be lit.

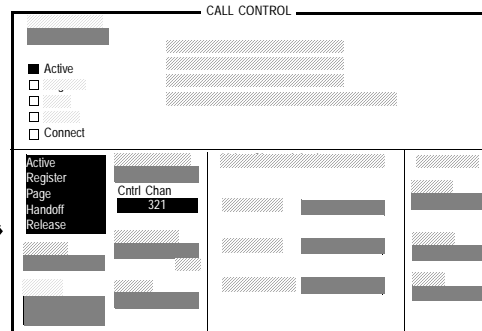

5. Page the mobile station.

1. Select Page in the field shown.

The mobile station should ring.

2. Press SEND on the mobile station handset.

The Connect annunciator should now be lit.

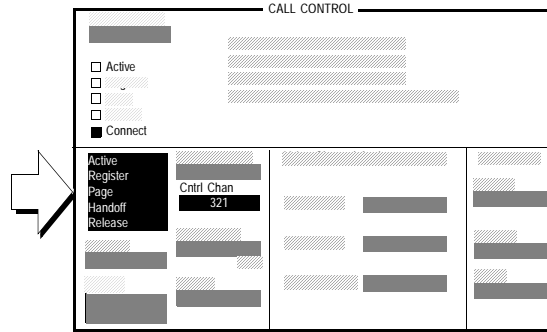

Transmitter Measurements (no audio connections required)

1. Display analog measurements.

1. Set the Display field to Meas.

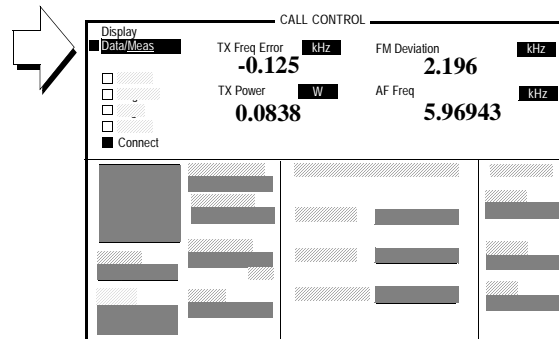

The measurements that are displayed on the CALL CONTROL screen indicate the mobile station's RF power, (TX Power) carrier frequency error (TX Freq Error), Supervisory Audio Tone (SAT) frequency (AF Freq), and SAT level (FM Deviation).

2. Set measurement limits for FM Deviation.

1. Position the cursor next to the FM Deviation units field.
2. Press then release the SHIFT key, then press the down-arrow key to select LO LIMIT.
3. Enter 1.8 kHz using the DATA keys and then press the knob.
4. Press then release the SHIFT key, then press the up arrow key to select HI LIMIT.
5. Enter 2.2 kHz using the DATA keys and then press the knob.

The Lo and Hi annunciators will appear below the displayed value of FM Deviation.

The limit values given in this procedure are based on an FM Deviation of approximately 2 kHz (peak+) deviation.

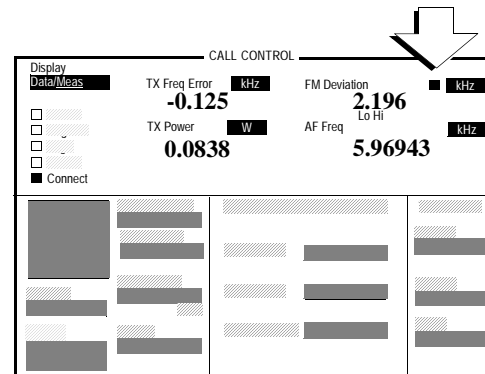

If the displayed value for FM Deviation exceeds either limit, the Test Set will beep and the corresponding annunciator will become brighter and flash. Press the MEAS RESET key to reset limit detection.

3. Access the Spectrum Analyzer (opt 102 only).

1. Press the SPEC ANL key.
2. Set the Span field to 100 kHz.

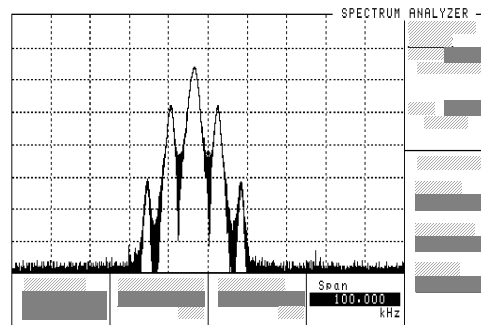

The Spectrum Analyzer is automatically tuned to the mobile station transmitter frequency.

The resolution bandwidth of the Spectrum Analyzer is coupled to the frequency span setting. With Span set to 100 kHz, the resolution bandwidth is 1 kHz.

Receiver Audio Distortion and Hum and Noise (requires audio connections)

1. Set up the receiver distortion measurement.

1. Press the ANLG MEAS key.
2. Set the FM level field to 8 kHz.
3. Set the AF Anl In field to Audio In.
4. Set the Filter 1 field to C MESSAGE.

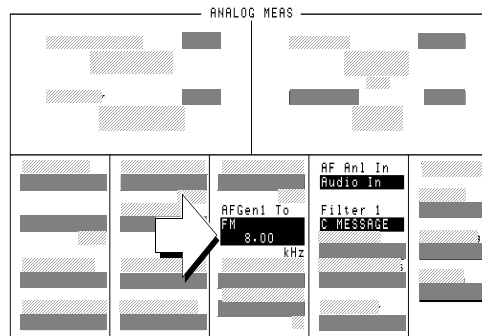

2. Make the receiver distortion measurement.

1. Select Distn in the field shown.
- The value displayed should be less than 5%

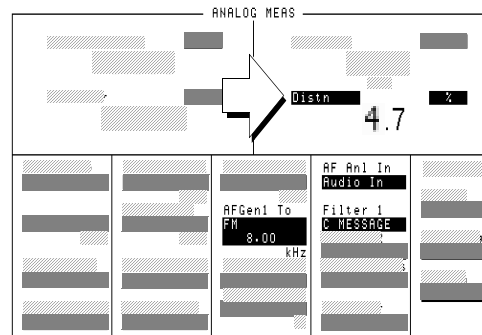

3. Set up the receiver hum and noise measurement.

1. Position the cursor in front of the AC Level field.
 2. Press then release the blue SHIFT key, then press the INCR \pm 10 key
 3. Press the knob to set a 0 dB reference.
- The AC Level field should display a value near 0 dB.

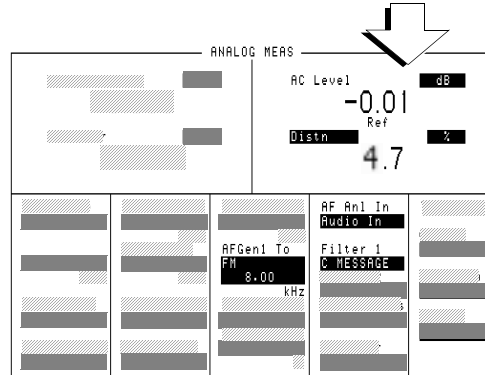

4. Make the receiver hum and noise measurement.

1. Position the cursor in front of the audio frequency generator field. Press the ON/OFF key.
- The AC Level field will display the FM hum and noise level. It should be at least 32 dB lower than the reference level.

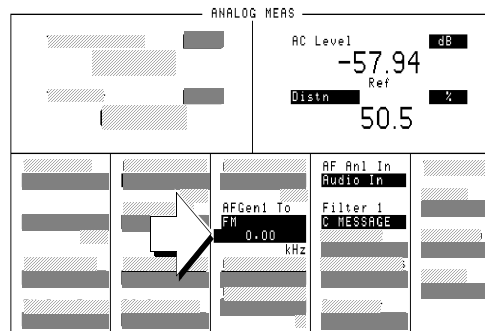

Turning off the audio frequency generator allowed the Test Set to display the ratio of FM without modulation (residual FM) to FM with the test signal applied, using the AC level reference value.

5. Set up the receiver RF sensitivity measurement.

1. Press the ON/OFF key again to turn the audio frequency generator back on.

2. Select SINAD.

The display should change from digital readout to a meter format.

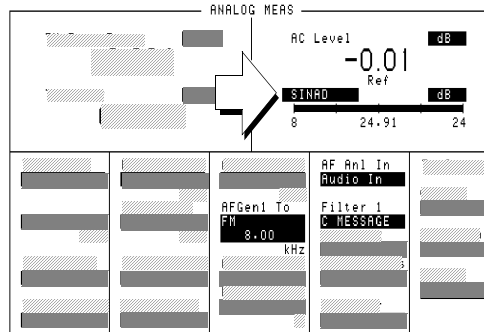

6. Turn on the averaging feature.

1. Position the cursor in front of the units field for the SINAD measurement.

2. Press then release the SHIFT key, then press the INCR $\times 10$ key to select AVG.

3. Using the DATA keys, enter 10 and press the knob.

The Avg annunciator should be displayed below the SINAD meter.

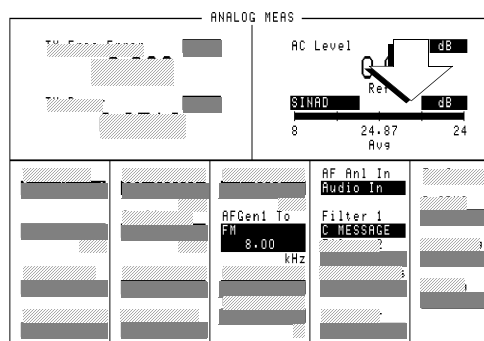

Averaging smooths out measurements that have rapid fluctuations, like the SINAD measurement.

7. Make the receiver RF sensitivity measurement.

1. Select the Amplitude field.
2. Enter -100 using the DATA keys and press the knob.
3. Press the INCR SET key and enter 0.5 dB using the DATA keys, then press the knob.
4. Press and release the SHIFT key, then the RECALL (SAVE) key. Enter SINAD using the letters in the Save: menu, then select Done (at the top of the Save menu).
4. Slowly turn the knob counterclockwise to adjust Amplitude until 12 dB SINAD is displayed on the meter.

If four dashes appear in the TX Freq Error field, the Amplitude was lowered too quickly and the call was dropped.

Re-establish the call using the CALL CONTROL screen. Press the RECALL key and select SINAD from the Recall: menu.

The Test Set should be ready to measure SINAD again.

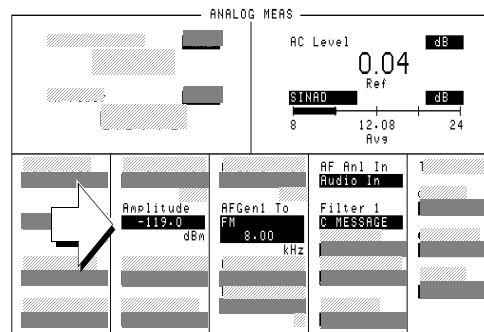

12 dB SINAD will be obtained at a very low signal level to the mobile station, probably below -110 dBm. For this reason, it is important to turn the knob slowly while watching the SINAD meter for changes.

Measurement Overview

Receiver Audio Harmonic Distortion is measured with the Test Set providing an FM signal to the mobile station, modulated by a test tone from the Test Set's audio frequency generator. (A SAT tone is also present on the RF signal). To measure distortion, the audio signal from the mobile station's earpiece (receiver output) is cabled to the Test Set's AUDIO IN connector. The Test Set's audio analyzer measures the level of the audio output, then notches out the test tone and measures only the RMS harmonic content produced by the audio signal. Distortion is then displayed as the percentage of mobile station receiver output level that was due to the harmonic content.

Typically, Audio Harmonic Distortion should be less than 5%.

Receiver hum and noise uses essentially the same setup as distortion, except that the modulation source is turned off, and residual FM is measured. The hum and noise measurement is the ratio of AC level from the mobile station's receiver without modulation to AC level with modulation.

Typically transmitter Hum and Noise should be at least 32 dB below levels with modulation on.

SINAD, a measure of receiver sensitivity, also uses essentially the same setup as distortion, except the RF amplitude to the mobile station's antenna input is lowered until 12 dB SINAD is reached. SINAD measurements are the ratio of the test signal plus noise and distortion components to just the noise and distortion.

Transmitter Audio Distortion and Hum and Noise (requires audio connections)

1. Set up the transmitter distortion measurement.

1. Set the Amplitude field to -50.0 dBm.
2. Set the AFGen1 To field to Audio Out.
3. Set the AF Anl In field to FM Demod.
4. Set the Filter 1 field to C Message.

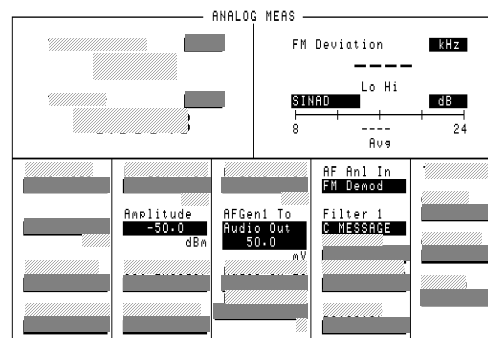

2. Define a USER key for adjusting audio level.

1. Position the cursor in front of the audio generator level field as shown.
 2. Press then release the blue SHIFT key, then press K4 (ASSIGN).
 3. Press then release the blue SHIFT key again, then press K1 (K1').
- The message “Global User key 1 assigned” should be displayed at the top of the screen.

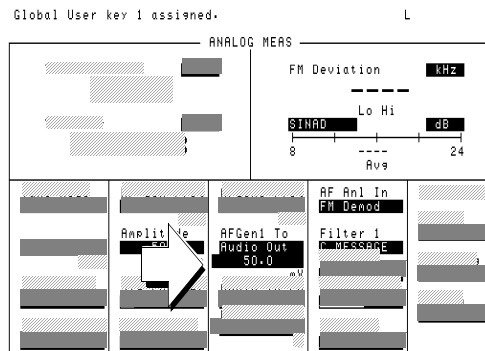

The Audio Generator level field can now be called from any screen.

3. Access the Test Set's Oscilloscope.

1. Press the SCOPE key.
2. Set the Controls field to Marker.
3. Select the Marker To, Peak+ field.

Observe the amount of FM deviation in the Lvl field as shown.

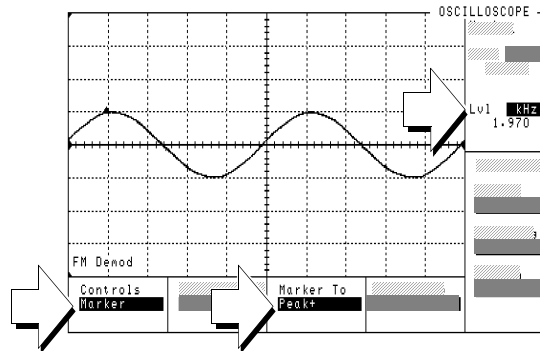

The Oscilloscope is automatically set to display the demodulated FM signal from the mobile station.

4. Adjust the peak frequency deviation.

1. Press then release the blue SHIFT key, then press K1.
- The AF Gen 1 Level field will appear at the top of the display.
2. Press the knob and adjust the level until about 8 kHz of deviation is observed in the Lvl field.
 3. Press the knob again to de-select the AF Generator field.

3. Select the Marker To, Peak- field.

The Peak- field should display approximately -8 kHz of FM deviation in the Lvl field.

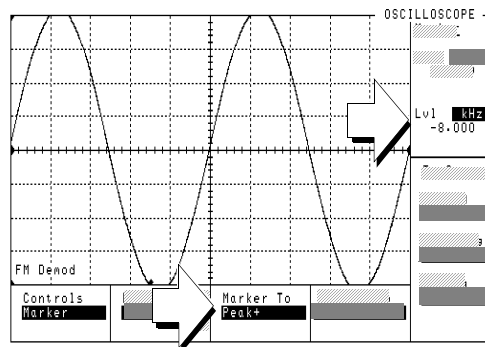

5. Make the transmitter distortion measurement.

1. Press the PREV key to return to the ANALOG MEAS screen.

The Hi limit annunciator should be flashing.

2. Select Distn.

Observe the value displayed next to the Distn field. It should be less than 5%.

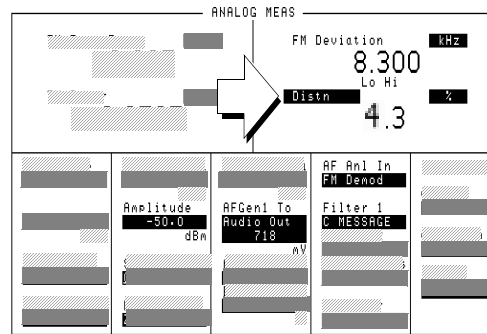

6. Set up the transmitter hum and noise measurement

1. Position the cursor next to the FM Deviation field.

2. Press then release the blue SHIFT key, then press the INCR ÷10 key.

3. Press the knob to set a 0 dB reference.

The new value displayed should be close to 0 dB.

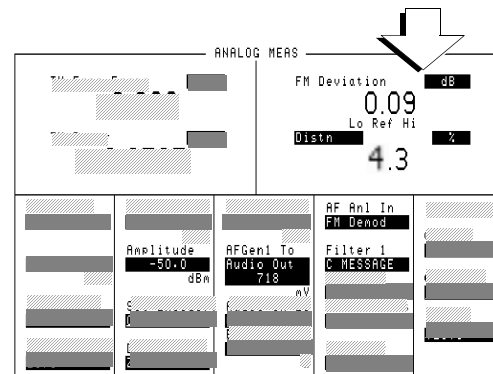

The FM Deviation field is displayed whenever the AF Anl In field is set to FM Demod.

7. Make the transmitter hum and noise measurement.

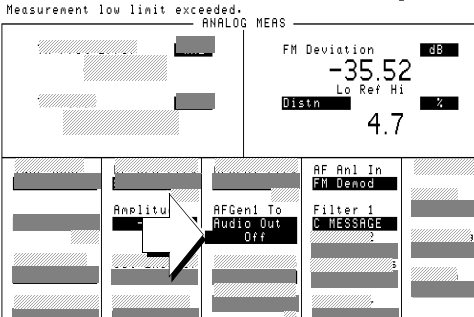
<p>1. Position the cursor in front of the audio frequency generator level field as shown. Press the ON/OFF key.</p> <p>The Lo and Hi limit annunciators should be flashing.</p> <p>The FM Deviation field will display the FM hum and noise level. It should be at least 32 dB lower than the reference level.</p>	 <p>Measurement low limit exceeded. ANALOG MEAS</p> <p>FM Deviation -35.52 dB</p> <p>Lo Ref Hi</p> <p>Distn 4.7 %</p> <p>AF Anl In FM Demod</p> <p>Amplitud AFGen1 To Audio Out Off</p> <p>Filter 1 C MESSAGE</p>
<p><i>Setting the 0 dB reference allowed the Test Set to display the ratio of FM without modulation (residual FM) to FM with the test signal applied, in the FM Deviation field.</i></p>	

Measurement Overview

Transmitter Distortion (and Noise) is measured with a test tone adjusted to frequency modulate the mobile station’s transmitter with a specified deviation. The FM signal from the mobile station’s transmitter is demodulated by the Test Set using a C-message weighted filter, and distortion and noise are measured.

Typically, distortion should be less than 5%.

Transmitter Hum and Noise is measured by modulating the mobile station’s transmitter with a test tone adjusted to produce a specified amount of deviation. With the signal from the mobile station’s transmitter demodulated by the Test Set using a C-message weighted filter, the amount of deviation is recorded. To determine the hum and noise, which is caused by residual FM, the modulation is removed and the ratio of residual FM to FM with the test signal on is calculated.

Typically, FM Hum and Noise should be less than -32 dB.

Short Message Service Tests

The following SMS tests verify that the Mobile Station Under Test (Mobile Station) is capable of receiving short messages.

Short messages can be sent:

- on the Paging/Access channels (phone has registered but is not on a traffic channel)
- on the Traffic channels (Service Option 6 or 14)
- on the Traffic channels (Service Option 1 or 32768)

All SMS procedures performed by the Test Set are mobile station terminated, meaning that the Test Set is sending messages to the Mobile Station.

The short message feature for the Mobile Station must be activated to perform these tests.

List of CDMA SMS Tests

"Sending Short Messages on the Paging/Access Channels" on page 99.

"Sending Short Messages on the Traffic Channels" on page 107.

Sending Short Messages on the Paging/Access Channels

This procedure sends a short message to the Mobile Station on the Paging channel. The Test Set verifies that the Mobile Station acknowledged receiving the SMS message.

1. Register the Mobile Station.

If the Mobile Station is already registered, this step is not necessary.

See "[Setting up a Call](#)" on page 43 if you are not familiar with how this procedure is performed with the Test Set.

Registering the Mobile Station will ensure that it is monitoring the Test Set's Paging channel.

2. Optional: Clear (erase) old messages in the Mobile Station.

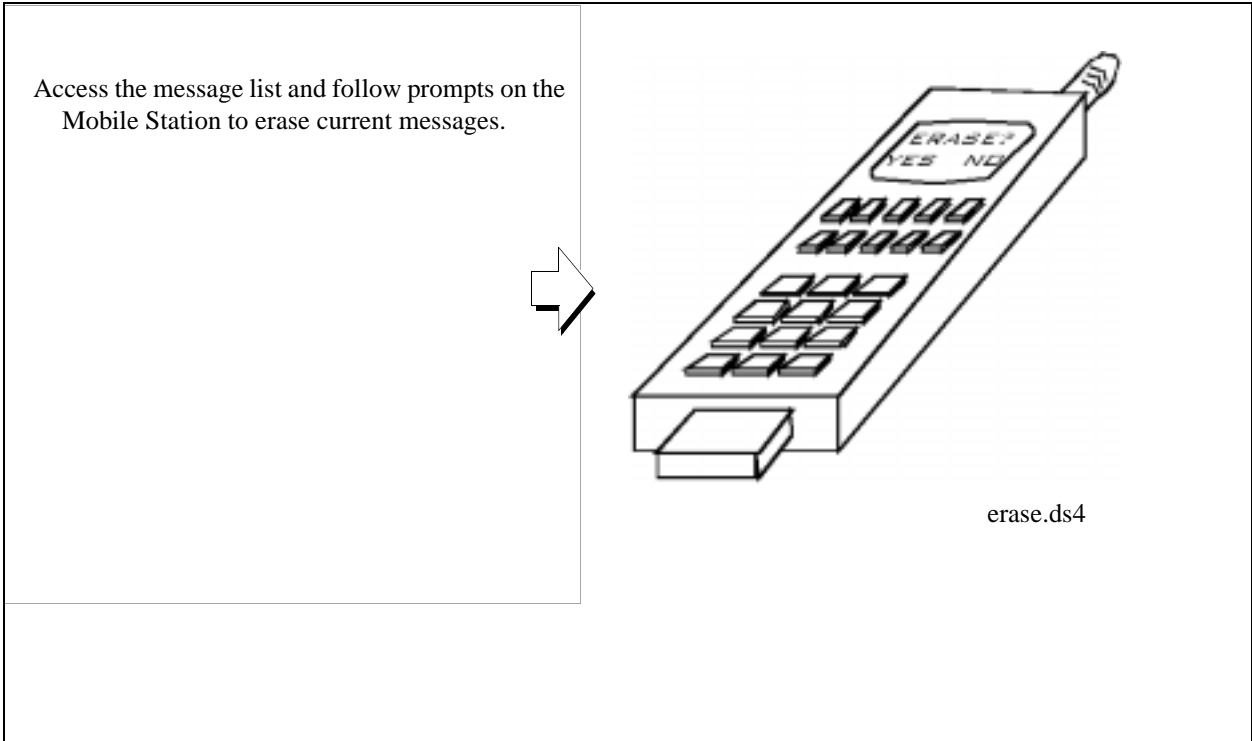

3. Select the data format for the SMS message.

1. Select SMS from the To Screen, CDMA list to display the CDMA SHORT MESSAGE SERVICE screen.
2. Position the cursor in front of the Data Mode field. Select the data format.
3. Position the cursor in front of the Encoding field. Select an encoding type.

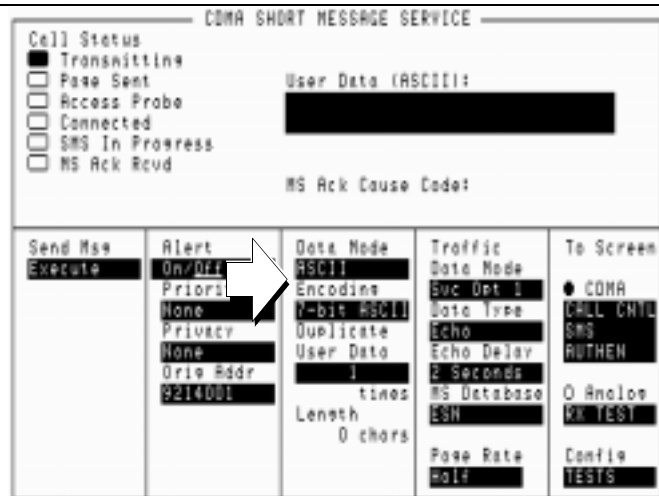

sms1.pcx

The choice you make in the Data Mode field determines what type of characters you will enter in the User Data field, ASCII or hexadecimal. If you select ASCII, the Test Set translates User Data according to the ASCII code chart. If you select Hex, no translation is applied.

The Encoding field will determine if character data is encoded as either 7-bit or byte format.

Chapter 5, Short Message Service Tests
Sending Short Messages on the Paging/Access Channels

4. Enter a short message in the Test Set's data field.

1. Position the cursor in front of the data field shown.
2. Press the knob and enter a message. Select Done when done.

sms3.pcx

5. Set the Page Rate.

1. Set the Page Rate field to Full.

CDMA SHORT MESSAGE SERVICE

Call Status
 Transmitting
 Page Sent
 Access Probe
 Connected
 SMS In Progress
 MS Ack Rcvd

User Data (ASCII):
http://www.hp.com/go/india

MS Ack Cause Code:

Send Msg	Alert	Data Mode	Traffic	To Screen
Execute	On/Off	ASCII	Data Mode	<input checked="" type="checkbox"/> CDMA
	Priority	Encoding	Sub Opt 1	<input type="checkbox"/> CALL CNTRL
	None	N-bit ASCII	Data Type	<input type="checkbox"/> SMS
	Privacy	Duplicate	Echo Delay	<input type="checkbox"/> AUTHEN
	None	User Data	2 Seconds	<input type="checkbox"/> Analog
	Orig Addr	Length	MS Database	<input type="checkbox"/> RX TEST
	9214001	26 chars	ESN	Config
			03054268	TESTS
			Page Rate	
			Full	

sms8.pcx+newfield.pcx

Setting the Page Rate field to Full provides more Paging Channel slots to send the Data Burst Message in.

Chapter 5, Short Message Service Tests
Sending Short Messages on the Paging/Access Channels

6. Send the message.

1. Select the Send Msg Execute.

The SMS in Progress annunciator will light when the message is sent, and remain lit until an acknowledgment is received or SMS times out.

The MS Ack Rcvd will light when the Test Set has received an SMS Acknowledgment message from the Mobile Station.

sms2.pcx+newfield.pcx

sms4.pcx+newfield.pcx

Cell Status	CDMA SHORT MESSAGE SERVICE			
<input checked="" type="checkbox"/> Transmitting	User Data (ASCII): http://www.hp.com/es/tdir			
<input type="checkbox"/> Page Sent	MS Ack Cause Code:			
<input type="checkbox"/> Access Probe	<input type="checkbox"/> Connected	<input checked="" type="checkbox"/> SMS In Progress	<input type="checkbox"/> MS Ack Rcvd	
Send Msg	Alert	Data Mode	Traffic	To Screen
Execute	On/Off	ASCII	Data Mode	<input checked="" type="radio"/> CDMA
	Priority	Encoding	Svc Det 1	<input type="radio"/> CALL CNTL
	None	7-bit ASCII	Data Type	<input type="radio"/> SMS
	Privacy	Duplicate	Echo	<input type="radio"/> AUTHEN
	None	User Data	Echo Delay	<input type="radio"/> Analog
	Orig Addr	1	2 Seconds	<input type="radio"/> RX TEST
	9214001	times	MS Database	Config
		Length	ESH	TESTS
		26 chars	03054268	
			Page Rate	
			Full	

Cell Status	CDMA SHORT MESSAGE SERVICE			
<input checked="" type="checkbox"/> Transmitting	User Data (ASCII): http://www.hp.com/es/tdir			
<input type="checkbox"/> Page Sent	MS Ack Cause Code:			
<input type="checkbox"/> Access Probe	<input type="checkbox"/> Connected	<input type="checkbox"/> SMS In Progress	<input checked="" type="checkbox"/> MS Ack Rcvd	
Send Msg	Alert	Data Mode	Traffic	To Screen
Execute	On/Off	ASCII	Data Mode	<input checked="" type="radio"/> CDMA
	Priority	Encoding	Svc Det 1	<input type="radio"/> CALL CNTL
	None	7-bit ASCII	Data Type	<input type="radio"/> SMS
	Privacy	Duplicate	Echo	<input type="radio"/> AUTHEN
	None	User Data	Echo Delay	<input type="radio"/> Analog
	Orig Addr	1	2 Seconds	<input type="radio"/> RX TEST
	9214001	times	MS Database	Config
		Length	ESH	TESTS
		26 chars	03054268	
			Page Rate	
			Full	

Measurement Overview

1. "Register the Mobile Station." on page 100.
See "Setting up a Call" on page 43.
2. "Optional: Clear (erase) old messages in the Mobile Station." on page 101.
3. "Enter a short message in the Test Set's data field." on page 103.
4. "Set the Page Rate." on page 104.
5. "Send the message." on page 105.

Sending Short Messages on the Traffic Channels

This procedure sends a short message to the Mobile Station on the Traffic channels. The first message will be sent without setting up a call (Service Option 6 or 14), and the second message will be sent while the Mobile Station is on a call (Service Option 1 or 32768).

1. Register the Mobile Station.

If the Mobile Station is already registered, this step is not necessary.

See "[Setting up a Call](#)" on page 43 if you are not familiar with how this procedure is performed with the Test Set.

Registering the Mobile Station will ensure that it is monitoring the Test Set's Paging channel.

2. Optional: Clear (erase) old messages in the Mobile Station.

Access the message list and follow prompts on the Mobile Station to erase current messages.

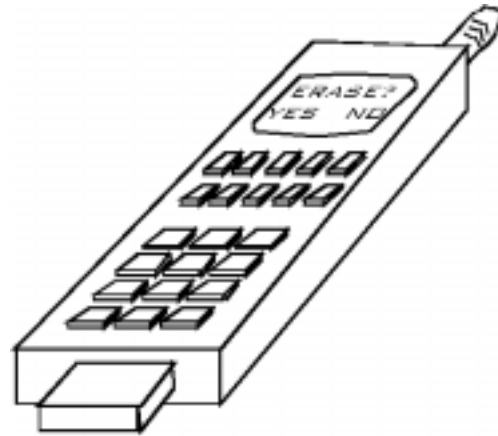

erase.ds4

3. Enter a short message in the Test Set's data field.

1. Select SMS from the To Screen, CDMA list.
2. Position the cursor in front of the data field shown.
3. Press the knob and enter a message. Select Done when done.

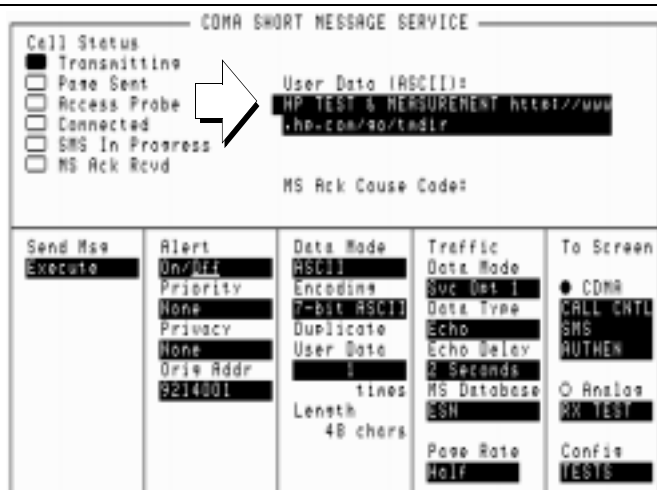

sms12.pcx

Chapter 5, Short Message Service Tests
Sending Short Messages on the Traffic Channels

4. Send the message.

1. Select Svc Opt 6 or 14.
2. Press the CALL key.

The MS Ack Rcvd will light when the Mobile Station has sent an acknowledgment that it received the message.



sms5.pcx+newfield.pcx

Selecting Service Option 6 will select Rate Set 1 (9600 bps full rate).

Selecting Service Option 14 will select Rate Set 2 (14400 bps full rate).

5. Enter another short message in the Test Set's data field.

1. Position the cursor in front of the data field shown.
3. Press the knob and enter the second message. Select Done when done.



sms6.pcx+newfield.pcx

Chapter 5, Short Message Service Tests
Sending Short Messages on the Traffic Channels

6. Make a call.

1. Select Svc Opt 1 or 32768.
 2. Press the **CALL** key.
 3. When the Mobile Station rings, press the **SEND** (or green) key on the Mobile Station's keypad to connect the call.
- The **Connected** annunciator must be lit before proceeding to the next step.

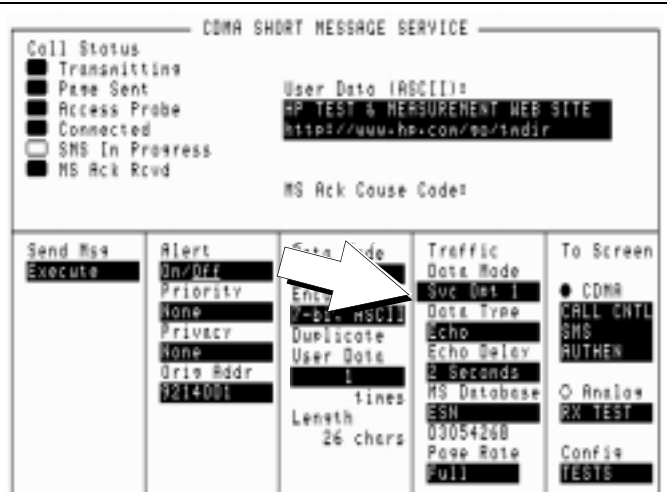

sms7.pcx+newfield.pcx

7. Send the message.

1. Select the Send Msg Execute field.

The SMS in Progress annunciator will light when the message is sent, and remain lit until an acknowledgment is received or SMS times out

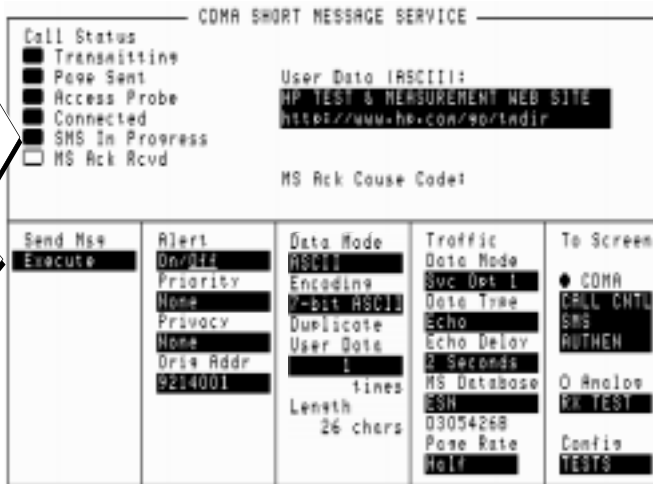

sms10.pcx+newfield.pcx

The MS Ack Rcvd will light when the Mobile Station has sent an SMS Acknowledgment message.



sms11.pcx+newfield.pcx

Measurement Overview

1. "Register the Mobile Station." on page 108.
See "Setting up a Call" on page 43.
2. "Optional: Clear (erase) old messages in the Mobile Station." on page 109.
3. "Enter a short message in the Test Set's data field." on page 110.
4. "Send the message." on page 111.
5. "Enter another short message in the Test Set's data field." on page 112.
6. "Make a call." on page 113.
7. "Send the message." on page 114.

Authentication Tests

The following Authentication tests verify that the Mobile Station Under Test (Mobile Station) is able to use the Cellular Authentication and Voice Encryption (CAVE) algorithm correctly.

For Authentication tests to pass, the Mobile Station and Test Set must possess identical sets of Shared Secret Data (SSD). SSD consists of two subsets:

- SSD_A (used for Authentication procedures) and
- SSD_B (used to support voice privacy)

NOTE:

In this section, the acronym SSD will be used to refer to SSD_A.

Authentication test results are displayed in a portion of the display referred to as the Authentication Data Table.

Parameter	Expected	Received	Status
AUTH	-	-	
RANDC	-	-	
COUNT	-	-	
AUTH.MODE	0	0	Passed

List of CDMA Authentication Tests

"Initializing SSD to Zero" on page 119.

"Updating SSD" on page 127.

"Performing a Unique Challenge-Response" on page 134.

Initializing SSD to Zero

This procedure tests the Mobile Station's ability to respond to a timer-based registration with authentication parameters that match the values expected by the Test Set.

This procedure is performed after SSD has been initialized to zero in both the Test Set and Mobile Station. SSD is initialized to zero by changing the A-Keys. *If you cannot change the A-Key in the Mobile Station, you cannot perform this test.*

NOTE:

SSD is not directly accessible in any fields on the Test Set's display.

1. Register the Mobile Station.

If the Mobile Station is already registered, this step is not necessary.

See "[Setting up a Call](#)" on page 43 if you are not familiar with how this procedure is performed with the Test Set.

Registration provides the Test Set with the Mobile Station's ESN (Electronic Serial Number).

ESN is displayed in the MS Database field.

Authentication procedures rely on ESN to generate valid A-Keys and compute numbers used to check for possession of identical SSD (shared secret data) between the Mobile Station and Test Set.

2. Initialize the Test Set's SSD to zero.

1. Select Authen in the To Screen, CDMA list.

If the SSD_A=0 annunciator is lit, performing the rest of this step is not necessary.

2. Position the cursor in front of the A-Key field.

3. Enter any number within the allowable range of A-Key values, using the DATA keys. Press the ENTER key when the number has been entered.

The SSD_A=0 annunciator should be lit.

The Check Digits field should display a six-digit number.¹



Entering an A-Key initializes SSD to zero.

The range of values allowed in the A-Key field is 0 to 18446744073709551615.

The number you entered in the A-Key field, along with the Mobile Station's ESN acquired during registration, are used by the Test Set to generate the six digits displayed in the Check Digits field. If no Check Digits appear, make sure an ESN value is displayed in the MS Database field.¹

The Check Digits are part of the A-Key, and provide a method for checking A-Key validity.

If the ESN changes (for instance when another Mobile Station is connected to the Test Set and registers) or is cleared, the Check Digits field will be cleared.

1. If Kor PCS is selected in the Protocol field, the Check Digits field should be blank.

3. Initialize the Mobile Station's SSD to zero.

1. Access the Mobile Station's A-Key register and enter the identical sequence of digits displayed in the A-Key field, followed by the six Check Digits (if protocol is not Kor PCS).

The Mobile Station should confirm the entry of a valid

This step instructs you to enter the A-Key displayed in the A-Key field because it is assumed to be valid (the Test Set calculated Check Digits based on the 20 A-Key digits and Mobile Station's ESN acquired during registration). This procedure, however, will work with any valid A-Key, since any valid A-Key will initialize the Mobile Station's SSD to zero.

If you cannot change the Mobile Station's A-Key but you know what it is, enter it in the A-Key field on the Test Set (as described in the previous step), then skip to "[Updating SSD](#)" on page 127.

4. Turn on Authentication.

1. Position the cursor at the Authen field.
2. Press the knob to select On.



CDMA AUTHENTICATION			
Cell Status	Registration with Authen: Passed		
	Registration Type: Power-up		
<input checked="" type="checkbox"/> Transmitting	Parameter	Expected	Received Status
<input type="checkbox"/> Registering	AUTH	-	-
<input type="checkbox"/> Pass Sent	RANDC	-	-
<input type="checkbox"/> Access Probe	COUNT	-	-
<input type="checkbox"/> Connected	AUTH.MODE	0	0 Passed
<input type="checkbox"/> SSD Update			
<input type="checkbox"/> Uniq Chall			
<input checked="" type="checkbox"/> SSD_A=0			
A_KEY	Check Digits	MS ID	To Screen
00000000000000000000	174518	Auto	● CDMA
Authen		Traffic	CALL CNTL
On/Off		Data Mode	SMS
Timer Rev		Sup Det 1	AUTHEN
On/Off		Data Type	○ Analog
SSD Update		Echo	RX TEST
Execute		Echo Delay	Config
Uniq Chall	Authen Data	2 Seconds	TESTS
Execute	Clear		

Selecting "On" in this field results in the Test Set signaling the Mobile Station to include authentication parameters in messages requiring authentication (AUTH_MODE =1).

5. Perform a timer-based registration.

1. Position the cursor at the Timer Reg field.
2. Press the knob to select On.
3. Wait for the first registration to complete (about 20 seconds).



Read the Registration with Authen: message in the Authentication Data Table. It will indicate whether the registration passed or failed.

If the test failed, check the passed or failed status of each of the following parameters: AUTHR, RANDC, COUNT, and AUTH_MODE to see which parameters did not match expected values.

After the first timer-based registration is performed, the expected COUNT parameter will be "Unknown." The Status of COUNT will be "Failed," until the next registration when an Expected COUNT parameter is available.

CDMA AUTHENTICATION				
Cell Status		Registration with Authen: Failed Registration Type: Timer		
<input checked="" type="checkbox"/> Transmitting	<input type="checkbox"/> Registering	<input type="checkbox"/> Page Sent	<input type="checkbox"/> Access Probe	<input type="checkbox"/> Connected
<input type="checkbox"/> SSD Update	<input type="checkbox"/> Uniq Chall	<input checked="" type="checkbox"/> SSD_A=0		
Parameter	Expected	Received	Status	
AUTHR	250EA	250EA	Passed	
RANDC	34	34	Passed	
COUNT	Unknown	3	Failed	
AUTH_MODE	1	1	Passed	
A_KEY 000000000000000000000000		Check Digits 139763	MS ID Auto	To Screen
Authen On/Off	Timer Reg On/Off	SSD Update Execute	Uniq Chall Execute	Authen Data Clear
Traffic Data Mode Suc Opt 1 Data Type Echo Echo Delay 2 Seconds	MS Database ESN B0000000			
<input checked="" type="checkbox"/> CDMA <input type="checkbox"/> CALL CNTL <input type="checkbox"/> SMS <input type="checkbox"/> AUTHEN <input type="checkbox"/> Analog <input type="checkbox"/> RX TEST <input type="checkbox"/> Config <input type="checkbox"/> TESTS				

CDMA AUTHENTICATION				
Cell Status		Registration with Authen: Passed Registration Type: Timer		
<input checked="" type="checkbox"/> Transmitting	<input type="checkbox"/> Registering	<input type="checkbox"/> Page Sent	<input type="checkbox"/> Access Probe	<input type="checkbox"/> Connected
<input type="checkbox"/> SSD Update	<input type="checkbox"/> Uniq Chall	<input checked="" type="checkbox"/> SSD_A=0		
Parameter	Expected	Received	Status	
AUTHR	SCEE	SCEE	Passed	
RANDC	34	34	Passed	
COUNT	1B	1B	Passed	
AUTH_MODE	1	1	Passed	
A_KEY 000000000000000000000000		Check Digits 174518	MS ID Auto	To Screen
Authen On/Off	Timer Reg On/Off	SSD Update Execute	Uniq Chall Execute	Authen Data Clear
Traffic Data Mode Suc Opt 1 Data Type Echo Echo Delay 2 Seconds	MS Database ESN B08197F4			
<input checked="" type="checkbox"/> CDMA <input type="checkbox"/> CALL CNTL <input type="checkbox"/> SMS <input type="checkbox"/> AUTHEN <input type="checkbox"/> Analog <input type="checkbox"/> RX TEST <input type="checkbox"/> Config <input type="checkbox"/> TESTS				

Registrations should occur at about 20 second intervals.

The Mobile Station and Test Set combine SSD with a random number and the ESN of the phone when computing AUTHR. This value is transmitted by the Mobile Station, then compared (along with other Authentication parameters) with the expected value by the Test Set to determine Pass/Fail status.

6. Disable timer-based registration.

1. Position the cursor at the Timer Reg field.
2. Press the knob to select Off.



CDMA AUTHENTICATION			
Registration with Authen: Passed			
Registration Type: Timer			
Parameter	Expected	Received	Status
AUTHR	SCEE	SCEE	Passed
RANDC	34	34	Passed
COUNT	10	10	Passed
AUTH.MODE	1	1	Passed

A.KEY 00000000000000000000	Check Digits 174518	MS ID Auto	To Screen															
<table border="1"> <tr><td>Ruthen</td><td>On/Off</td></tr> <tr><td>Timer Reg</td><td>On/Off</td></tr> <tr><td>SSD Update</td><td>Execute</td></tr> <tr><td>Uniq Chall</td><td>Execute</td></tr> <tr><td>Authen Data</td><td>Clear</td></tr> </table>	Ruthen	On/Off	Timer Reg	On/Off	SSD Update	Execute	Uniq Chall	Execute	Authen Data	Clear	<table border="1"> <tr><td>Traffic Data Mode</td><td>2 Seconds</td></tr> <tr><td>MS Database</td><td>ESH</td></tr> <tr><td>MS Database</td><td>808197F4</td></tr> </table>	Traffic Data Mode	2 Seconds	MS Database	ESH	MS Database	808197F4	<ul style="list-style-type: none"> • CDMA CALL CNTL SMS AUTHEN O Anclos Rx TEST Confio TESTS
Ruthen	On/Off																	
Timer Reg	On/Off																	
SSD Update	Execute																	
Uniq Chall	Execute																	
Authen Data	Clear																	
Traffic Data Mode	2 Seconds																	
MS Database	ESH																	
MS Database	808197F4																	

Measurement Overview

1. **"Register the Mobile Station." on page 120.**
See **"Setting up a Call" on page 43.**
2. **"Initialize the Test Set's SSD to zero." on page 121.**
Screen: CDMA AUTHENTICATION
Enter value in: **A-Key**
3. **"Initialize the Mobile Station's SSD to zero." on page 122.**
4. **"Turn on Authentication." on page 123.**
Screen: CDMA AUTHENTICATION
Make selection in **Authen**
5. **"Perform a timer-based registration." on page 124.**
Screen: CDMA AUTHENTICATION
Make selection in **Timer Reg**
6. **"Disable timer-based registration." on page 125.**
Screen: CDMA AUTHENTICATION
Make selection in **Timer Reg**

Updating SSD

SSD Update tests the Mobile Station's ability to synchronize SSD with the Test Set.

This procedure will show you how to perform SSD Update on the Paging/Access channels. SSD Updates can also be performed on the Traffic channels by making a call then performing this procedure.

During the SSD update, the Test Set and Mobile Station acquire new sets of SSD using their current A-Keys. The Test Set and the Mobile Station then compare the new SSD values and the Mobile Station sends a message to the Test Set confirming or rejecting the new value.

No authentication parameters are displayed in the CDMA Authentication table during this test.

1. Register the Mobile Station or Set Up a Call.

If the Mobile Station is already registered or a call is connected, this step is not necessary.

See "[Setting up a Call](#)" on page 43 if you are not familiar with how either of these procedures is performed using the Test Set.

Setting up a call registers the Mobile Station.

Registration provides the Test Set with the Mobile Station's ESN (Electronic Serial Number).

ESN is displayed in the MS Database field.

Authentication procedures rely on ESN to generate valid A-Keys and generate other values used to check for possession of identical SSD between the Mobile Station and Test Set.

2. Enter the Mobile Station’s A-Key into the Test Set.

If you performed "Initializing SSD to Zero" on page 119, this step is not necessary.

1. Enter the most significant 20 digits (non-check-digits) of the Mobile Station’s A-Key into the Test Set’s A-Key field using the DATA keys. Press the ENTER key when you are done.

The SSD_A=0 annunciator should be lit.

2. Compare the numbers in the Check Digits field with the last 6 digits in the Mobile Station’s A-Key. If they do not match, one of the A-Keys is not valid. Check the 20-digit sequence entered in the Test Set to be sure it matches the Mobile Station’s A-Key.

CDMA AUTHENTICATION

Cell Status Registration with Authen: Passed
 Registration Type: Power-up

Parameter	Expected	Received	Status
AUTH	-	-	
RANDC	-	-	
COUNT	-	-	
AUTH.MODE	0	0	Passed

A-KEY	Check Digits	MS ID	To Screen
00000000000000000000	174518	Auto	● CDMA CALL CNTL SMS AUTHEN
Authen On/Off		MS Database ESN	○ Analog RX TEST
Timer Rev On/Off			Config TESTS
SSD Update Execute			
Uniq Chall Execute	Authen Data Clear		
		Traffic Data Mode Sup Det 1 Data Type Echo Echo Delay 2 Seconds	

If you do not know the Mobile Station’s A-Key, and have no way of finding out what it is, try entering zero in the A-KEY field. The A-Key in many Mobile Station’s is initially programmed to zero until re-programmed by the

3. Turn Authentication On

1. Position the cursor at the Authen field
2. Press the knob to select On.



Turning Authentication "On" sets the AUTH_MODE bit to "01" in signaling messages and causes the Mobile Station to send Auth parameters AUTHR, RANDC, and COUNT to the Test Set.

4. Perform an SSD Update

1. Select the SSD Update Execute field.

The SSD Update annunciator will light, but this may be only momentarily.



CDMA AUTHENTICATION			
Parameter	Expected	Received	Status
Call Status			
<input checked="" type="checkbox"/> Transmitting			
<input type="checkbox"/> Registering			
<input type="checkbox"/> Page Sent			
<input type="checkbox"/> Access Probe			
<input type="checkbox"/> Connected			
<input checked="" type="checkbox"/> SSD Update			
<input type="checkbox"/> Unix Chall			
<input checked="" type="checkbox"/> SSD_A=0			
A_KEY	Check Divis	MS ID	To Screen
000000000000000000000000	174518	Auto	
Authen		Traffic	
On/Off		Data Mode	
Timer Res		Src Opt 1	
On/Off		Data Type	
SSD Update		Echo	
Execute		Echo Delay	
Unix Chall	Authen Data	2 Seconds	
Execute	Clear		

During the SSD Update, the Mobile Station and Test Set combine the A-Key with a common random number, RANDSSD, and then compare results to determine if SSD matches. RANDSSD is a settable value (see RANDSSD field on the CDMA CELL SITE CONFIGURATION screen) sent from the Test Set to the Mobile

5. Check the message displayed for test results.

Read the SSD Update on Paging (or Traffic): message. It will indicate whether SSD Update passed or failed.

After a successful SSD Update, the SSD_A=0 annunciator should no longer be lit.

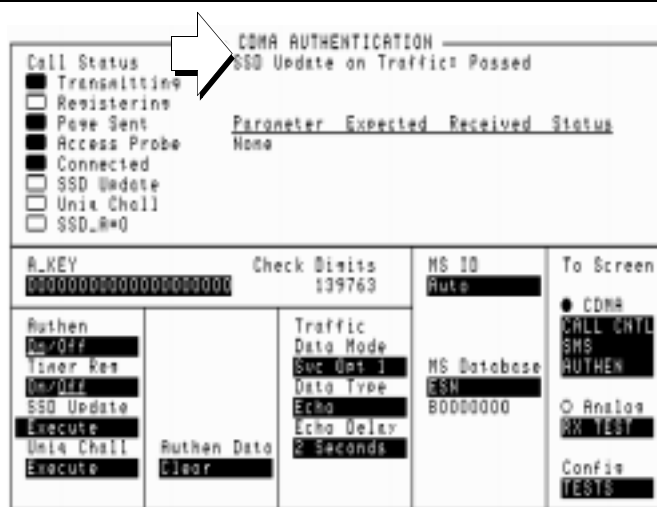

After new values for SSD are computed and compared between the Mobile Station and Test Set, the Mobile Station transmits a message to the Test Set indicating the status of the SSD Update (passed or failed).

Measurement Overview

1. **"Register the Mobile Station or Set Up a Call." on page 128.**
See **"Setting up a Call" on page 43.**
2. **"Enter the Mobile Station's A-Key into the Test Set." on page 129.**
3. **"Turn Authentication On" on page 130.**
Screen: CDMA AUTHENTICATION
Enter value in: **A-Key**
4. **"Perform an SSD Update" on page 131.**
Screen: CDMA AUTHENTICATION
Make selection in **Timer Reg**
5. **"Check the message displayed for test results." on page 132.**
Screen: CDMA AUTHENTICATION
Observe: Authentication Data Table.

It is recommend the following procedures be performed after Updating SSD to further verify correct Mobile Station performance:

- **"Performing a Unique Challenge-Response" on page 134**

Performing a Unique Challenge-Response

Unique Challenge-Response tests the Mobile Station's ability to send the Test Set a parameter that indicates it has SSD identical to the Test Set's.

This procedure will show you how to perform a Unique Challenge-Response procedure on the Paging/Access and Traffic channels. The Mobile Station should respond with a computed value for AUTHU, which the Test Set will compare with an expected value to determine Pass/Fail status.

1. Synchronize SSD between the Test Set and Mobile Station.

1. Perform either:
 - *Initializing SSD to Zero, or
 - * Updating SSD

Performing either of these procedures synchronizes the SSD value stored in the Test Set with the SSD value stored in the Mobile Station.

2. Select Unique Challenge.

1. End a call if Call Status is Connected

2. Select the Uniq Chall field.

The Uniq Chall annunciator should light momentarily.

The screenshot shows the 'CDMA AUTHENTICATION' menu. At the top, there is a 'Call Status' section with several options: Transmittine, Registering, Page Sent, Access Probe, Connected, SSD Update, Uniq Chall, and SSD_A=0. Below this is a table with columns for 'Parameter', 'Expected', 'Received', and 'Status'. The 'Uniq Chall' option is highlighted with a black bar. Below the table, there are several sections: 'A_KEY' (displaying 'XXXXXXXXXXXXXXXXXXXX'), 'Check Digits' (174510), 'MS ID' (Auto), 'MS Database' (ESN), and 'MS ID' (808197F4). There are also sections for 'Authen' (On/Off), 'Timer Req' (On/Off), 'SSD Update' (Execute), 'Uniq Chall' (Execute), 'Traffic Data Mode' (Suc Opt 1), 'Data Type' (Echo), 'Echo Delay' (2 Seconds), 'Authen Data' (Clear), and 'To Screen' (CDMA, CHLL CHIL, SMS, AUTHEN, Q Anolov, RM TEST, Confile, TESTS).

This step performs a Unique Challenge on the Paging/Access channels.

3. Check the Authentication Data Table for results.

1. End a call if Call Status is Connected
2. Select the Uniq Chall field.

Read the Unique Challenge on Paging (or Traffic): message. It will indicate whether the Unique Challenge passed or failed.

Check the Authentication Data Table for AUTHU Pass/Fail results.

Parameter	Expected	Received	Status
AUTHU	3084B	3084B	Passed

If the Unique Challenge on Paging (or Traffic): Failed message appears, it means that AUTHU did not match the expected value.

4. Perform an Mobile Station-originated call.

1. Enter any phone number on the Mobile Station's keypad and press the SEND (or green) key.

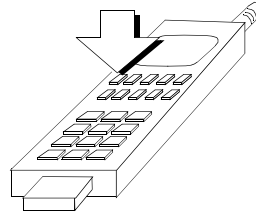

CDMA AUTHENTICATION			
Cell Status: Origination with Authen Passed			
<input checked="" type="checkbox"/> Transmitting	Parameter	Expected	Received Status
<input type="checkbox"/> Registering	AUTHR	2C594	2C594 Passed
<input type="checkbox"/> Page Sent	RAHDC	34	34 Passed
<input checked="" type="checkbox"/> Access Probe	COUNT	3	3 Passed
<input type="checkbox"/> Connected	AUTH.MODE	1	1 Passed
<input type="checkbox"/> SSD Update			
<input type="checkbox"/> Unique Chall			
<input checked="" type="checkbox"/> SSD_A=0			
A_KEY 00000000000000000000	Check Digits 139763	MS ID Auto	To Screen ● CDMA CALL CNTL SMS AUTHEN ○ Analog RX TEST Config TESTS
Authen On/Off Timer Res On/Off SSD Update Execute Unique Chall Execute	Authen Data Clear	Traffic Data Mode Svc Opt 1 Data Type Echo Echo Delay 2 Seconds	MS Database ESN 00000000

After Send (or green) is pressed on the Mobile Station, the Access Probe annunciator on the Test Set, will light to indicate that the mobile station sent an access probe sequence in an attempt to gain system access.

Some Mobile Station's require the number entered to be at least six digits long.

5. Perform the Unique Challenge.

1. Select the Uniq Chall field.

Read the Unique Challenge on Traffic: message. It will indicate whether the unique challenge passed or failed.

Check the Authentication Data Table for AUTHU Pass/Fail results.

The screenshot shows a mobile phone's authentication test interface. At the top, it says "CDMA AUTHENTICATION" and "Unique Challenge on Traffic: Passed". Below this is a table with the following data:

Parameter	Expected	Received	Status
AUTHU	3084B	3084B	Passed

Below the table, there are several sections with options:

- A.KEY**: 00000000000000000000
- Check Digits**: 174510
- MS ID**: Auto
- To Screen**: COMRA, CALL CNTL, SMS, AUTHEN, O Anolog, PK TEST, Config, TESTS
- Authen**: On/Off, Timer Res, On/Off, SSD Update, Execute, Uniq Chall, Execute
- Traffic Data Mode**: Suc Det 1, Data Type, Echo, Echo Selor, 2 Seconds
- Authen Data**: Clear
- MS Database**: ESN, 808197F4

If the Unique Challenge on Paging (or Traffic): Failed message appears, it means that AUTHU did not match the expected value.

Measurement Overview

1. "Synchronize SSD between the Test Set and Mobile Station." on page 135.
2. "Select Unique Challenge." on page 136.
3. "Check the Authentication Data Table for results." on page 137.

It is recommended that you perform a Unique Challenge-Response after "Initializing SSD to Zero" on page 119 and after "Updating SSD" on page 127.

Protocol Logging

The CDMA protocol logging feature allows the capture of over-the-air forward and reverse IS-95A messages on the traffic channel or paging/access channel.

This logging feature is intended to be used as a low-level tool to aid the advanced user in debugging new phone designs or qualifying the operation of new mobile stations.

CAUTION:

Operation and setting changes made using the information contained in this module can negatively affect system operation. Agilent Technologies makes no claim or warranty of proper operation or fitness of use when the user has altered the operation of the unit using these techniques.

Hardware and Software Requirements

Using the protocol logging functions of the Test Set requires a number of specific hardware and software items not supplied directly by Agilent Technologies. It is the user's responsibility to acquire those items not provided by Agilent Technologies.

CAUTION:

Attempting to use hardware and software items other than those specified in this module may result in unsatisfactory performance. Agilent Technologies does not make any claims of suitability as to the form and/or function of such substitutions.

Hardware Requirements

Three pieces of hardware, besides the Test Set and mobile station, are required to use the protocol logging functions of the Test Set.

- An industry standard PC compatible computer¹
- Break-out Adapter Agilent P/N 08924-61029 (37 pin "D" connector to two 9-pin and one 15-pin "D" connectors)

The break-out adapter is shipped as standard equipment with the Test Set.

- A null-modem cable, no more than six feet in length.

The null-modem cable is not provided by Agilent Technologies, but is a readily available standard serial cable. The end of the null-modem cable that mates to the Test Set (break-out adapter) will be a nine-pin male sub-miniature "D". The end that connects to the computer will be a nine-pin female male sub-miniature "D" or a 25-pin sub-miniature "D", depending on the computer. The User Manual for PROCOMM PLUS² (see "[Software Requirements](#)" on page 143) shows diagrams for making a null-modem cable from an RS-232 cable.

1. The computer should be equipped with a buffered 16550 UART (Universal Asynchronous Receiver/Transmitter). This will allow serial communication even if the processor is busy and cannot immediately handle the serial port interrupt requests. A 486 33MHz class microprocessor is adequate, but a 586 100 MHz class processor will reduce the likelihood of missed characters sent from the Test Set.
2. PROCOMM PLUS is a product of Datastorm Technologies, Inc.

Software Requirements

The computer must have a communications software package installed that is capable of the following:

- Handling a null modem serial connection
- Supporting a baud rate of 115 kbps
- Emulating a VT 100 terminal.

The following communications packages have been tested and verified to work for protocol logging:

- PROCOMM PLUS version 2.01 for MS-DOS from Datastorm Technologies, Inc. running with MS-DOS version 2.0 or later (Agilent Technologies recommends MS-DOS version 6.22).
- HyperTerminal (comes with Windows 95). Agilent Technologies recommends a 486 66 MHz class microprocessor and 16 MBytes of RAM for Windows 95.

Connecting the Test Set to the Computer

CAUTION:

Be sure that a null-modem cable connected to the Test Set is never left unterminated. It must remain connected to the computer's serial port. Because data on the protocol logging connectors is transferred at a very high speed, an unterminated or poor quality null-modem cable could generate internal cross talk, causing the Test Set to behave erratically and possibly crash.

1. Install the break-out adapter.

1. Remove the metal cover plate from the Cell Site/Triggers rear-panel connector, if one is present.
2. Attach the break-out adapter to the Cell Site/Triggers connector.
3. Do not over tighten the attaching screws.

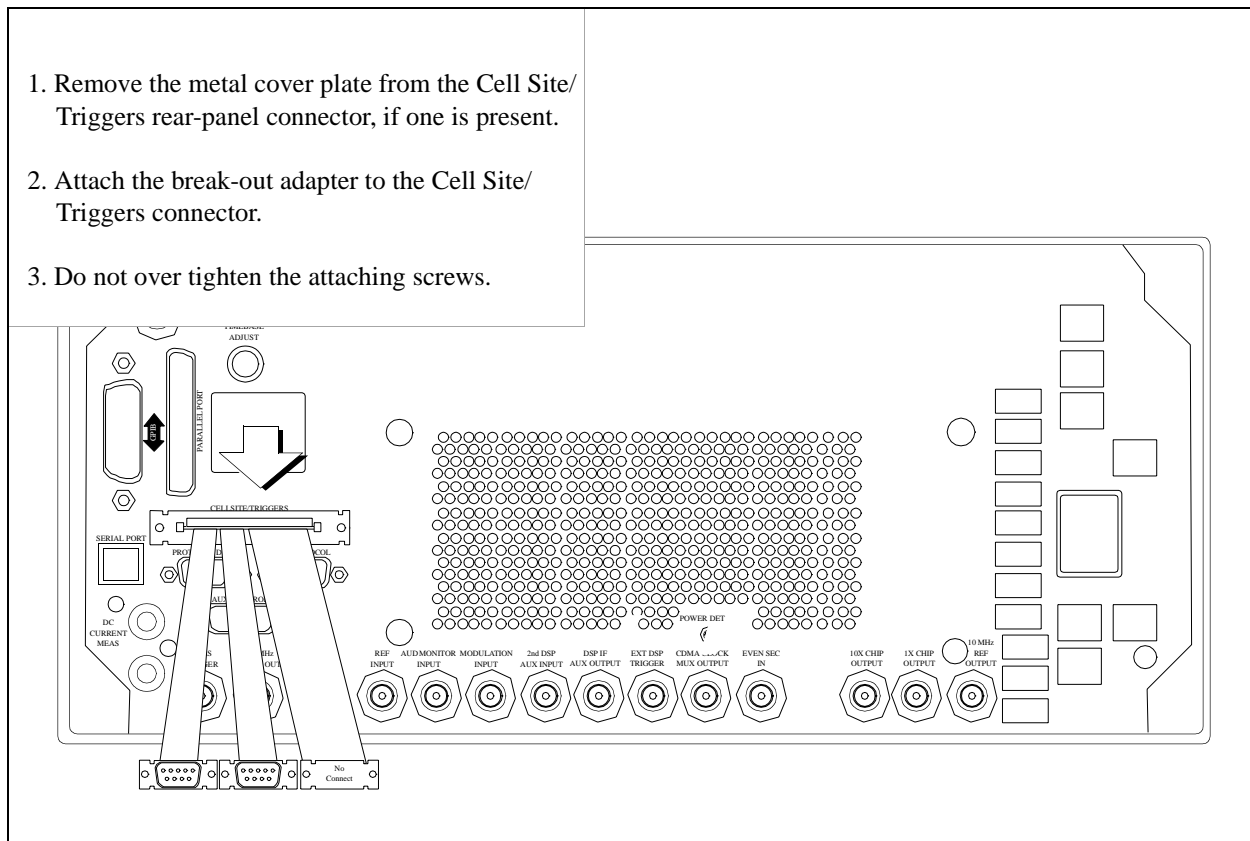

2. Make the connection between the Test Set and the computer.

- 1. Connect one end of the null-modem cable to Logging Port 1 on the break-out adapter.
- 2. Connect the other end of the null-modem cable to the serial port on the computer.

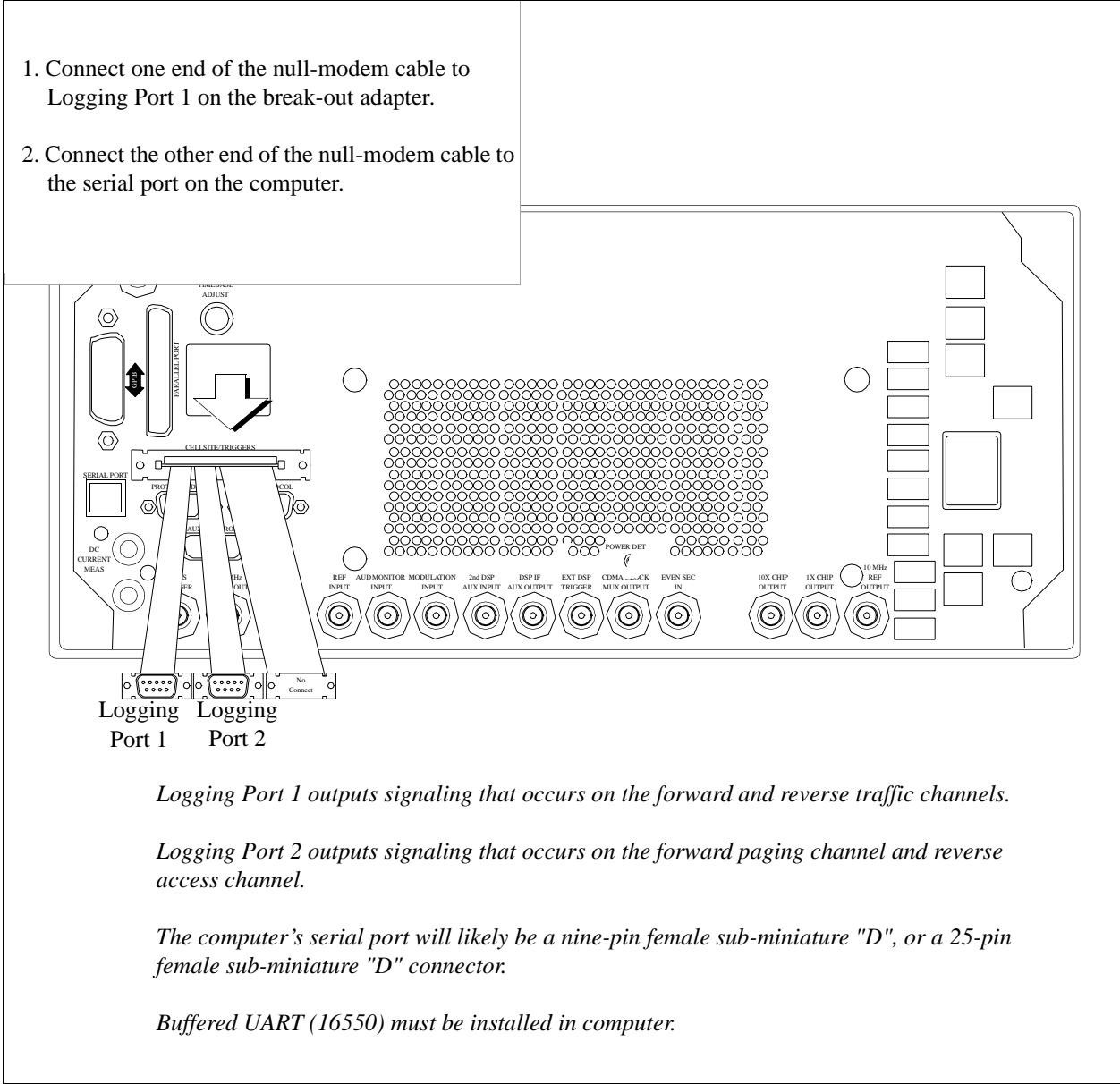

Setting Up the Communications Package

This section will provide the general settings for configuring a communications package for protocol logging with the Test Set. If you are using PROCOMM PLUS, detailed setup information for installing or reconfiguring PROCOMM PLUS is provided.

General Setup Parameters

- *Baud Rate.....115,200*
- *Parity.....None*
- *Data Bits.....8*
- *Stop Bits.....1*
- *Terminal Emulation...VT100*

Installing PROCOMM PLUS

The following list includes the setup information that PROCOMM PLUS version 2.01 for MS-DOS from Datastorm Technologies, Inc. will prompt you for during installation.

PROCOMM PLUS Prompt Settings

- Prompt: How will you use PROCOMM PLUS?
Choose: With a Direct Connection Only
- Prompt: COM Ports
Choose: Available serial port
- Prompt: Baud Rates
Choose: 115200
- Prompt: Communication Settings
Choose: No Parity, 8 data bits (Required for Test Set)
- Prompt: TERMINAL FAMILY
Choose: VT/AMSI (Required for Test Set)
- Prompt: DEFAULT TERMINAL EMULATION
VT100 (Required for Test Set)
- DEFAULT DOWNLOAD PROTOCOL
XMODEM (Required for Test Set)

Reconfiguring PROCOMM PLUS

If you already have PROCOMM PLUS installed on your computer, use the settings listed in the following steps to insure proper setup.

1. Start PROCOMM PLUS

- At the DOS prompt change directories to where you installed PROCOMM PLUS.
- Type pcplus, and press ENTER.
- Press any key to enter PROCOMM PLUS terminal mode.

2. Set Up "TERMINAL OPTIONS".

- While holding down the ALT key, press the S key.
This displays the PROCOMM PLUS SETUP UTILITY...MAIN MENU.
- Select "TERMINAL OPTIONS" from the list of choices.
This displays the PROCOMM PLUS SETUP UTILITY...TERMINAL OPTIONS.
- Follow the on screen directions for changing the settings.
A-Terminal emulation..... VT100
B- Duplex..... FULL
- Esc: Exit back to PROCOMM PLUS SETUP UTILITY...MAIN MENU.

3. Set Up "HOST MODE OPTIONS".

- Select "HOST MODE OPTIONS" from the list of choices.
- Follow the on screen directions for changing the setting for D- Connection Type to "DIRECT".
- Esc: Exit back to PROCOMM PLUS SETUP UTILITY...MAIN MENU.

4. Save the current settings to the PROCOMM PLUS Software.

- Select "SAVE SETUP OPTIONS" from the list of choices.
- Esc: Exit back to PROCOMM PLUS SETUP UTILITY...MAIN MENU.

5. Configure the computer's serial port.

- While holding down the ALT key, press the P key.

This displays the LINE/PORT SETUP screen.

- Type, next to the prompt "YOUR CHOICE", the characters that correspond to the following parameters:

BAUD RATE= 115200

PARITY = None

DATA BITS = 8

STOP BITS = 1

PORT = Available serial port

- Save the current settings to the PROCOMM PLUS Software (ALT S keys).

6. Verify serial communication with the Test Set.

- Apply power to the Test Set.

As the Test Set is going through its power-up cycle, messages should appear.

- Press the Enter key on your computer.
- If setup is correct, a prompt will be echoed back from the Test Set to the computer's screen.

DCS1> If serial port COM1 1 is selected

DCS2> If serial port COM2 is selected

Logging Protocol Messages

With PROCOMM PLUS configured correctly, the Test Set will display protocol messages on the computer display through the serial null-modem cable, which may be connected to Logging Port 1 or Logging Port 2 on the break-out adapter.

Logging Port 1 will provide all over-the-air messages sent by the Test Set on the Sync Channel and traffic channel messages sent and received by the Test Set on the forward and reverse traffic channels.

Logging Port 2 will provide all over-the-air messages sent on the paging channel and received by the Test Set on the access channel. By system default, certain paging channel messages that are continuously repeated (those which are not intended for a specific mobile station) are not displayed. These include the System Parameters Message, Access Channel Parameters Message, Channel List Message, Extended System Parameters Message, and the Extended Neighbor List Message. The "o" command, (see "[Logging Port 2 Commands](#)" on page 155) allows you to turn on or turn off these messages.

Along with protocol messages, PROCOMM PLUS (in its default mode) will also display:

- Internal control messages from the Test Set
- Frame-rate indicators for forward and reverse traffic channels

The following [example log](#) shows typical data that might be logged from Logging Port 1.

Table 4 Forward Channel Frame Rate Characters

	Frame Rate Indicators for Forward Channel (to mobile station)			
8 kbps*	'1' = full	'2' = half	'3' = quarter	'4' = eighth
13 kbps	'5' = full	'6' = half	'7' = quarter	'8' = eighth
* '0' = Corrupt frame				

Table 5 Reverse Channel Frame Rate Characters

	Frame Rate Indicators for Reverse Channel (to mobile station)			
8 kbps *	'F' = full 'f' = full rate likely	'-' = half	'_' = quarter	'.' = eighth
13 kbps	'S' = full 's' = full rate likely	' ' = half	'^' = quarter	':' = eighth
* '' = corrupt frame				

Capturing a Log to a File on the Computer

PROCOMM PLUS provides a capture mode that, when activated, stores all data to a file of your choice for further evaluation.

1. To begin logging, hold down the Alt key on the computer, press F1.
You will be prompted to provide a filename.
2. Type in a filename for the captured log.
3. When you have completed logging, hold down the ALT key and press F1.
The status bar at the bottom of the computer's display will indicate that the log has been closed.
4. You can evaluate the contents of your file now with any text editor.

Control Commands for Protocol Logging

Control commands allow modification to the protocol logging feature through the computer running the communications package (see "[Software Requirements](#)" on [page 143](#)). All commands are sent by typing a single character on the computer keyboard.

The menu of commands is displayed by typing a "?" (SHIFT, \).

Logging Port 1 Commands

NOTE:

A list of these commands can be displayed by pressing "?" on the computer keyboard.

"a" Pressing the "a" key on the computer keyboard causes the Test Set to display the active parameters for the access channel.

"b" For internal Agilent Technologies use only.

"c" Pressing the "c" key on the computer keyboard causes the Test Set to display its current CDMA channel parameters, such as Walsh code assignments and PN offsets. This information is settable on the CDMA GENERATOR CONTROL screen.

"d" Pressing the "d" key on the computer keyboard causes the computer to display compressed forward and reverse traffic channel data in hexadecimal format. Data is preceded by a code that indicates the frame data rate, and whether it was received (Rx) or transmitted (Tx). Refer to **"Forward Channel Frame Rate Characters" on page 151** and **"Reverse Channel Frame Rate Characters" on page 151** for the meaning of each code.

CAUTION:

During a call, traffic data is continually sent and received by the Test Set. Pressing the "d" key will cause the computer to log a tremendous amount of data. Pressing the "d" key again stops the display of data.

"e" For internal Agilent Technologies use only.

"f" For internal Agilent Technologies use only.

"i" For internal Agilent Technologies use only.

"l" It is not recommended that you use this command. This command toggles power control mode. A field on the CDMA TRANSMITTER POWER RANGE TEST screen, Closed Loop Pwr Cntl, should be used to perform this function.

"m" For internal Agilent Technologies use only.

"o" Pressing the "o" key will toggle a command mode that logs all sync channel overhead messages. Sync channel messages are continually sent by the Test Set, so be prepared for a large amount of data. Press "o" again to disable.

"p" Pressing the "p" key will toggle a command mode that logs a "D" for each down power control bit, and a "U" for each up power control bit. A power control bit is transmitted every 1.25 mS, so be prepared for a large amount of data. Press "p" again to disable.

"**q**" For internal Agilent Technologies use only.

"**r**" For internal Agilent Technologies use only.

"**s**" Pressing the "s" key will display the current parameters being used on the Sync Channel.

"**t**" Pressing the "t" key will display the current parameters being used on the Traffic Channel.

"**u**" For internal Agilent Technologies use only.

"**v**" For internal Agilent Technologies use only.

"**w**" For internal Agilent Technologies use only.

"**y**" Pressing the "y" key will display the current parameters used on the system overhead messages.

"**+**" For internal Agilent Technologies use only.

"**-**" For internal Agilent Technologies use only.

"**,**" Pressing the "," key will toggle a command mode that displays the Frame Rate Characters (see "**Forward Channel Frame Rate Characters**" on page 151 and "**Reverse Channel Frame Rate Characters**" on page 151). Toggling frame rate indicators off greatly reduces the amount of data logged.

"**.**" Pressing the "." key will toggle a command mode that displays a subset of the the Test Set's internal control messages, called Status Request Messages. Turning Status Request Messages off makes it easier to analyze protocol-related data.

Logging Port 2 Commands

NOTE:

A list of these commands can be displayed by pressing "?" on the computer keyboard.

"a" Pressing the "a" key on the computer keyboard causes the Test Set to display the active parameters for the access channel.

"b" For internal Agilent Technologies use only.

"c" Pressing the "c" key on the computer keyboard causes the Test Set to display its current CDMA channel parameters, such as Walsh code assignments and PN offsets. This information is settable on the CDMA GENERATOR CONTROL screen.

"f" For internal Agilent Technologies use only.

"i" For internal Agilent Technologies use only.

"m" Pressing the "m" key on the computer keyboard causes the Test Set to display the monitored parameters on the Access Channel. If the Test Set has detected access probes, this command will show if the information was good or bad via the message CRC counters.

"o" Pressing the "o" key will toggle a command mode that logs all sync channel overhead messages. Sync channel messages are continually sent by the Test Set, so be prepared for a large amount of data. Press "o" again to disable.

"p" Pressing the "p" key will display the current parameters being used on the Paging Channel.

"q" For internal Agilent Technologies use only.

"s" Pressing the "s" key will display the current parameters being used on the System Overhead Message.

"t" Pressing the "t" key will display System Time.

"u" For internal Agilent Technologies use only.

"**v**" For internal Agilent Technologies use only.

"**w**" For internal Agilent Technologies use only.

"**.**" Pressing the "." key will toggle a command mode that displays a subset of the the Test Set's internal control messages, called Status Request Messages. Turning Status Request Messages off makes it easier to analyze protocol-related data.

Symbols

"Enable timer-based registration." on
page 148, 126
*RST, 20, 43

A

access attempts, ignoring, 66, 68
access probe output power measurements, 65
amplitude error measurements, 55
arm measurement, 62
authentication
list of tests, 98, 118
authentication tests
initializing shared secret data to zero, 119
performing a unique challenge-response, 134
shared secret data update on a traffic channel, 132, 137, 138, 139
updating shared secret data, 127
average power measurements
selecting, 29
zeroing procedure, 27

C

cable loss
correcting for, 31
measuring, 33
calibrating
See also zeroing
calibration
recommendations, for zeroing average power, 27
call
mobile originated, 138
mobile terminated, 49
carrier feedthrough measurements, 55
CDMA to analog handoff, 77, 81
CDMA to CDMA interband handoff, 70
channel
selecting, 45, 46
channel level calibration
programming example, 21
channel power measurements
programming example, 25

D

default settings
 HP-IB syntax for setting, [20](#), [43](#)
demodulation
 forward traffic channel, [59](#)

E

Eb/Nt
 resolution of reading, [61](#), [63](#)

F

frame rate characters
 forward channel, [151](#)
 reverse channel, [151](#)
frequency error measurements, [55](#)

H

handoff
 CDMA to analog, [77, 81](#)
 CDMA to CDMA interband, [70](#)
 parameters, [78](#)

I

ignore access attempts, [66, 68](#)
Interband handoff, [70](#)
interim test results, [61](#)
loc
 definition, [59, 60](#)
IS-95A
 protocol selection, [44](#)

L

loading ROM program
 HP-IB syntax for, [21](#)
logging, CDMA protocol, [141](#)

M

maximum power measurements, [57](#)
measurements
 amplitude error, [55](#)
 carrier feedthrough, [55](#)
 demodulation of forward traffic channel with AWGN, [59](#)
 frequency error, [55](#)
 phase error, [55](#)
 power, access probe, [65](#)
 power, maximum, [57](#)
 power, minimum, [57](#)
 rho, [55](#)
 time offset, [55](#)
 waveform quality, [55](#)
message
 logging, CDMA protocol, [141](#)
minimum power measurements, [57](#)
MSUT
 definition, [44](#)

P

PCB_CAL, [21](#)
phase error measurements, [55](#)
power measurements
 access probe output power, [65](#)
 maximum closed/open loop, [57](#)
 minimum closed/open loop, [57](#)
presetting Test Set, [20](#), [43](#)
 HP-IB syntax for, [20](#), [43](#)
primary CDMA channel
 System A, [45](#), [46](#)
 System B, [45](#), [46](#)
programming example
 CDMA channel level calibration, [21](#)
 channel power calibration, [25](#)
 RF generator level calibration, [26](#)
protocol, [44](#)
protocol logging, [141](#)
 commands, [152](#)
 example log, [150](#)

Q

querying
 calibrating status event register, [25](#)

R

receiver tests
 demodulation of forward traffic channel with AWGN, 59
reset. *See* presetting instrument
RF channel
 selecting, 45, 46
RF channel standard, 44
RF generator level calibration procedure, 26
 programming example, 26
RF path loss
 correcting for, 31
 measuring, 33
rho measurements, 55
*RST, 20, 43
running ROM program, 21
 HP-IB syntax for, 21

S

SAT tolerance, wide, 80
shared secret data
 initializing to zero, 119
 updating, 127
shared secret data update
 traffic channel, 132, 137, 138, 139
short message service
 Sending short messages on the Paging/Access channels, 99
 sending short messages on the Traffic channels, 107
SMS tests
 sending short messages on the Paging/Access channels, 99
 sending short messages on the Traffic channels, 107
SSD
 see shared secret data, 119, 127, 132, 137, 138, 139
System A
 primary CDMA channel for EIA/TIA IS-95, 45, 46
System B
 primary CDMA channel for EIA/TIA IS-95, 45, 46

T

time offset measurements, 55
tolerance, SAT, 80
transmitter tests
 list of, 54
 waveform quality, 55

U

unique challenge-response, [134](#)

W

waveform quality measurements
list of, [55](#)
wide SAT tolerance, [80](#)

Z

zeroing
recommendations, for average power,
[27](#)
zeroing procedure
average power measurements, [27](#)