

---

**Getting Started with Your  
HP 9122D/S Disc Drive**



**April 1, 1986**

**Manual Part No.  
09122-90020**



## Manual Map

---



Set-Up  
Essentials for  
World-Wide Users

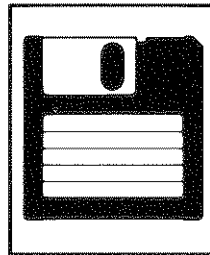

Chapter 3  
Using Flexible Discs

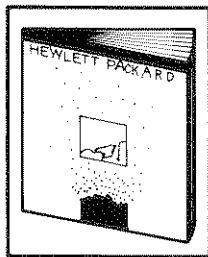

Chapter 1  
Introduction

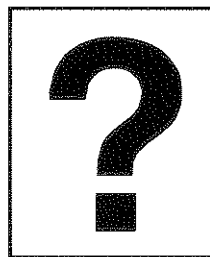

Chapter 4  
Problem Solving,  
Repairs, & Supplies

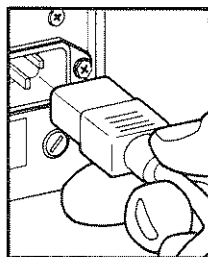

Chapter 2  
Setting Up

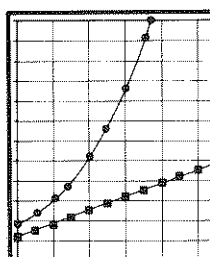

Technical Reference  
Glossary  
Index

---

## Limited Warranty

### One-year Limited Hardware Warranty

Hewlett-Packard warrants this peripheral/accessory against defects in materials and workmanship for a period of one year from receipt by the end user, except when used as part of an HP system. If HP receives notice of such defects during the warranty period, HP will either, at its option, repair or replace products which prove to be defective.

Should HP be unable to repair or replace the product within a reasonable amount of time, Customer's alternate exclusive remedy shall be a refund of the purchase price upon return of the product.

If this product was purchased as part of an HP system in a coordinated shipment, it is warranted against defects in material and workmanship during the same period as the HP system.

### Exclusions

The above warranty shall not apply to defects resulting from improper or inadequate maintenance by Customer; customer-supplied software or interfacing; unauthorized modification or misuse; operation outside of the environmental specifications for the product; or improper site preparation and maintenance.

The selection and use of media, supplies, and

consumables is the customer's responsibility. Hewlett-Packard reserves the right to exclude from the warranty or service agreement any repairs for damage to HP products which HP reasonably determines or believes were caused by use of non-HP media or cleaning supplies. Hewlett-Packard will, upon request, repair such damage on a time and material basis.

### Obtaining Warranty Service

To obtain warranty service, products must be returned to a service facility designated by HP. HP may repair on-site at the option of the customer. Customer is responsible for travel charges when on-site repair is requested.

Warranty service for products purchased as part of a system will be subject to service in accordance with the system support services.

Customer shall prepay shipping charges for products returned to HP for warranty service and HP shall pay for return of the products to customer. However, Customer shall pay all shipping charges, duties, and taxes for products returned to HP from another country.

### Warranty Limitations

HP makes no other warranty, either expressed or implied, with respect to this product. HP specifically disclaims the implied warranties of merchantability and fitness

for a particular purpose. Some states or provinces do not allow limitations on the duration of an implied warranty, so the above limitation or exclusion may not apply to you. However, any implied warranty of merchantability or fitness is limited to the one-year duration of this written warranty.

This warranty gives you specific legal rights, and you may also have other rights which vary from state to state, or province to province.

**Exclusive Remedies**

The remedies provided herein are customer's sole and exclusive remedies. In no event shall HP be liable for any direct, indirect, special, incidental, or consequential damages, whether based on contract, tort, or any other legal theory. Some states or provinces do not allow the exclusion or limitation of incidental or consequential damages, so the above limitation or exclusion may not apply to you.

HP offers complete service and maintenance worldwide. Maintenance agreements are available for HP peripheral products. Advantages of these agreements to the customer include a fixed annual cost, individualized cost-effective contracts, and a choice of response time. Current rates can be

determined by contacting your local HP Sales Office.

**Federal  
Communications  
Commission Radio  
Frequency  
Interference  
Statement – USA  
Only**

This equipment generates and uses radio frequency energy and may, if not installed and used properly, that is, in strict accordance with the manufacturer's instructions, cause interference to radio and television reception.

It has been type tested and found to comply with the limits for a Class B computing device in accordance with the specifications in Subpart J of Part 15 of FCC rules, which are designed to provide reasonable protection against such interference in a residential installation. Shielded data cables were used during the type test; therefore, properly shielded and terminated data cables should be used to reduce potential interference. However, there is no guarantee that interference will not occur in a particular installation. If this equipment does cause interference to radio or television reception, which can be determined by

turning the equipment off and on, the user is encouraged to try to correct the interference by one or more of the following measures.

- reorient the receiving antenna
- relocate the computer with respect to the receiver
- move the computer away from the receiver
- plug the computer into a different outlet so that computer and receiver are on different branch circuits.

If necessary, the user should consult the dealer or an experienced radio/television technician for additional suggestions.

Hiermit wird bescheinigt, daß das Gerät/System 9122D/S in Übereinstimmung mit den Bestimmungen von Postverfügung 1046/84 funkentstört ist.

Der Deutschen Bundespost wurde das Inverkehrbringen dieses Gerätes/Systems angezeigt und die Berechtigung zur Überprüfung der Serie auf Einhaltung der Bestimmungen eingeräumt.

#### **Zusatzinformation für Meß- und Testgeräte**

Werden Meß- und Testgeräte mit ungeschirmten Kabeln und/oder in offenen Meßaufbauten verwendet, so ist vom Betreiber sicherzustellen, daß die Funk-Entstörbestimmungen unter Betriebsbedingungen an seiner Grundstücksgrenze eingehalten werden.

If test and measurement equipment is operated with unshielded cables and/or used for measurements on open setups, the user has to assure that, under operating conditions, the Radio Interference Limits are still met at the border of his premises.

## **Essentials**

---

**Principes Essentiels  
Wesentliche Grundlagen  
Elementos Esenciales  
Informazioni Essenziali  
Nødvendige Trin  
Essentiël  
Perusominaisuudet  
Nødvendige Trinn  
Väsentlig**

# Table of Contents

## 1 INTRODUCTION

Introduction  
Einführung  
Introducción  
Introduzione  
Introduktion  
Inledning  
Johdanto  
Innledning  
Introduktion

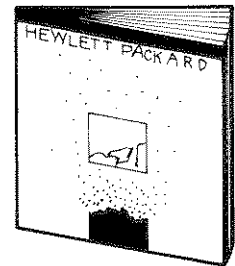

## 2 VOLTAGE

Tension  
Spannung  
Voltaje  
Tensione  
Strømstyrke  
Voltage  
Jännite  
Spänning  
Sänning

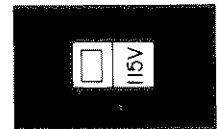

**CAUTION**

## 4 HP-IB

HP-IB  
HP-IB  
HP-IB  
HP-IB  
HP-IB  
HP-IB  
HP-IB  
HP-IB  
HP-IB

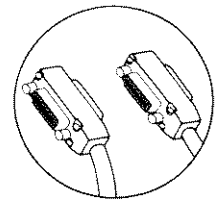

## 6 POWER

Mise sous tension  
Stromversorgung  
Alimentación  
Alimentazione  
Tilslutning  
Vermogen  
Teho  
Strømtilførsel  
Effekt

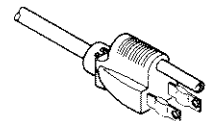



**7 ADDRESS**  
Adresse  
Adresse  
Dirección  
Indirizzo  
Programkode  
Adres  
Osoite  
Adresse  
Address

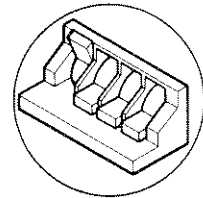

**8 SELFTEST**  
Autotest  
Selbtest  
Autoprueba  
Prova di autocontrollo  
Automatisk test  
Zelftest  
Itsetarkastuskoe  
Kontrollprøve  
Självtest

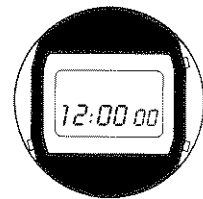

**11 USING YOUR FLEXIBLE DISC**  
Benutzen de Diskette  
Uso de los Discos flexibles  
Uso dei dischi flessibili  
Anvendelse af fleksible discs  
Gebruik van de Flexibele Diskette  
Levyjen käyttö  
Bruk av fleksible disketter  
Att använda skivminnen

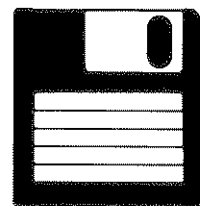

**16 FUSE**  
Fusible  
Sicherung  
Fusibile  
Fusibile  
Sikring  
Zekering  
Sulake  
Sikring  
Säkring

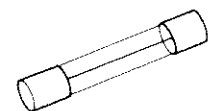

**WARNING**

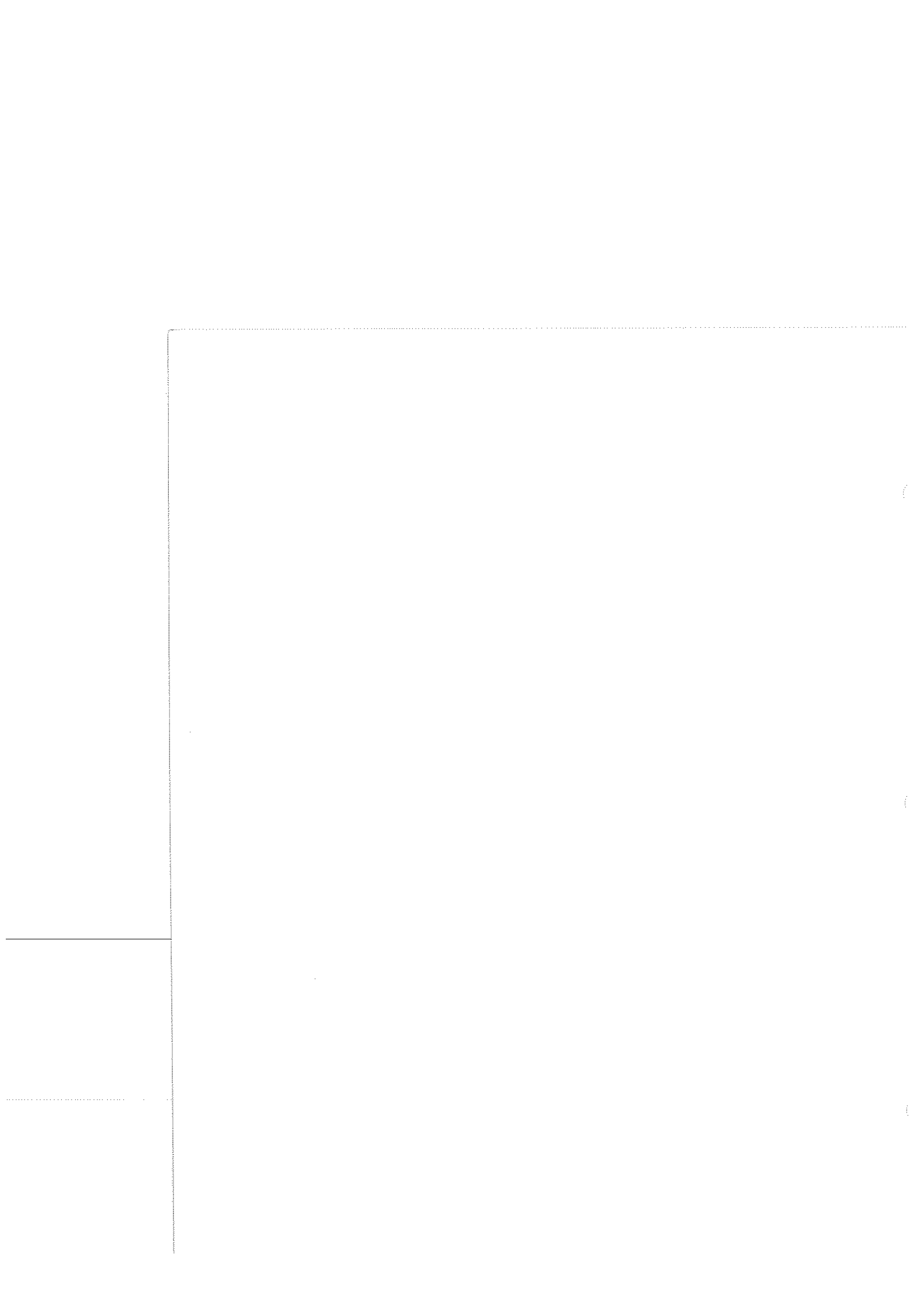

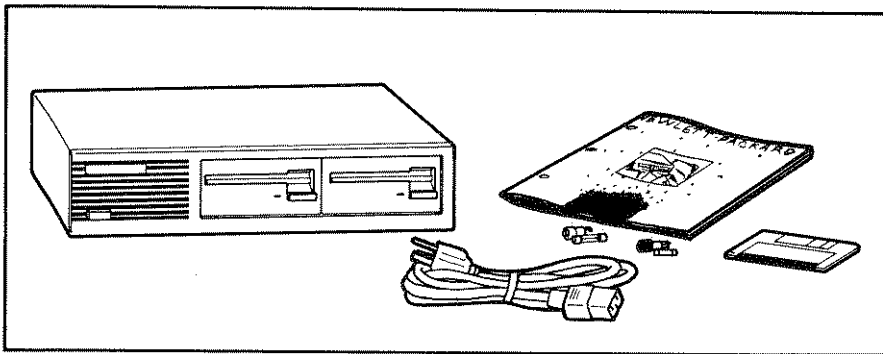
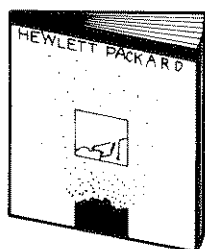



**CAUTION**

Make sure the voltage switch is set correctly for your local power. Always turn off the disc drive before changing the voltage setting.

Assurez-vous que le sélecteur de tension est mis sur la position qui correspond à votre courant. Arrêtez toujours l'unité de disques avant de changer la position du sélecteur.

Prüfen Sie nach, ob die Einstellung des Spannungsschalters der Netzspannung entspricht. Schalten Sie das Gerät jedesmal aus, bevor Sie die Spannungseinstellung verändern.

Asegúrese de que el selector de voltaje está debidamente ajustado, de acuerdo con la red local. Apague siempre la unidad de disco antes de cambiar el ajuste de voltaje.

Assicuratevi che il selettore di tensione sia posizionato correttamente per la vostra corrente locale. Disinserite sempre l'unità disco prima di cambiare il posizionamento della tensione.

Sørg for at spændingsknappen er korrekt indstillet til Deres strømstyrke. Sluk altid for disc-aktivatoren før De ændrer strømstyrke.

Verzekert U zich ervan dat de voltageschakelaar juist is afgesteld voor Uw plaatselijke stroom. Zet de disk drive altijd af alvorens de voltageschakelaar af te stellen.

Varmista, että jännitekytkin on asetettu paikallisen tehon mukaan. Kytke aina levyasema pois päältä ennenkuin vaihdat jänniteasetusta.

Bekreft at spenningsbryteren er innstilt på den rette nettspenningen. Skru alltid av disc-driven før De forandrer spenningsbryteren.

Försäkra dig om att spänningsomkopplaren har korrekt inställning enligt tillgänglig effekt. Slå alltid ifrån drivenheten för skivminne innan du ändrar spänningsinställningen.



CAUTION

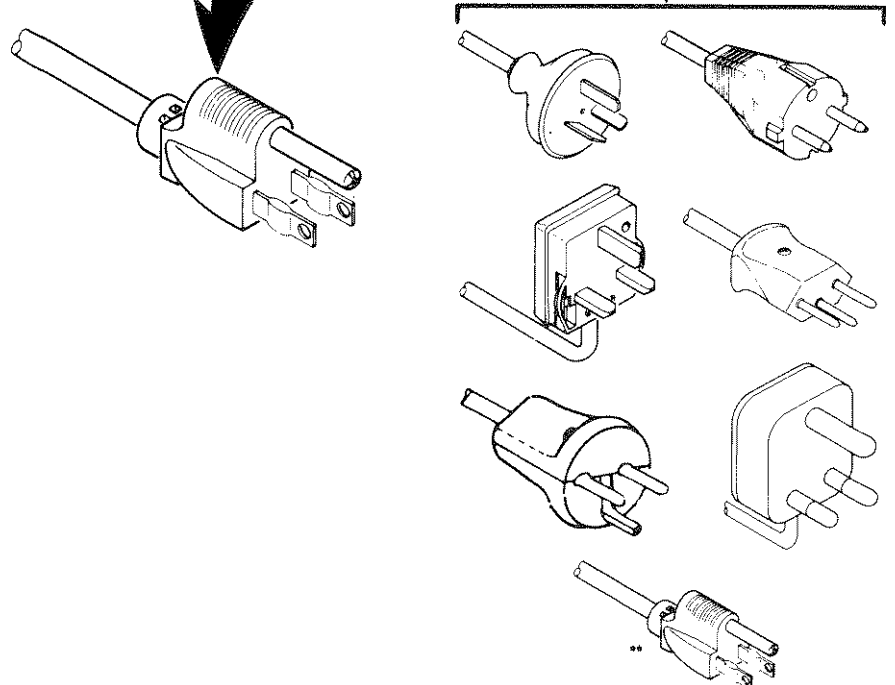
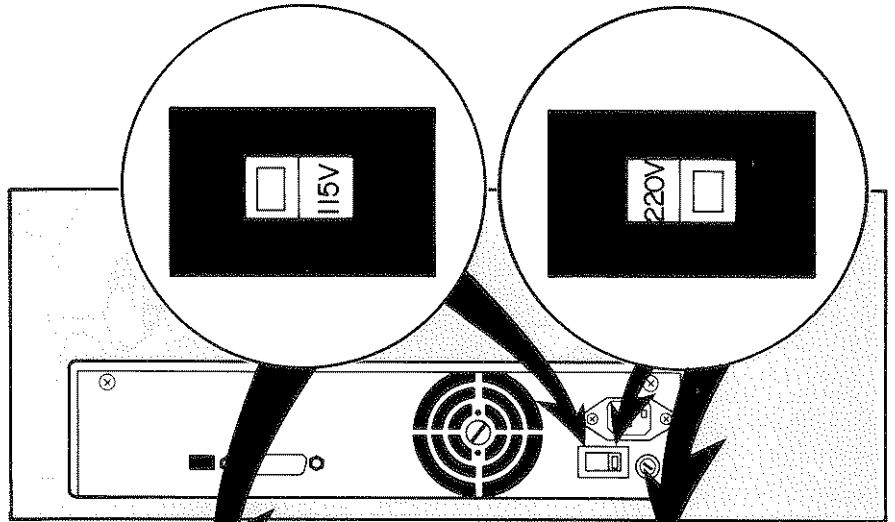

\*\*Peru - 220V

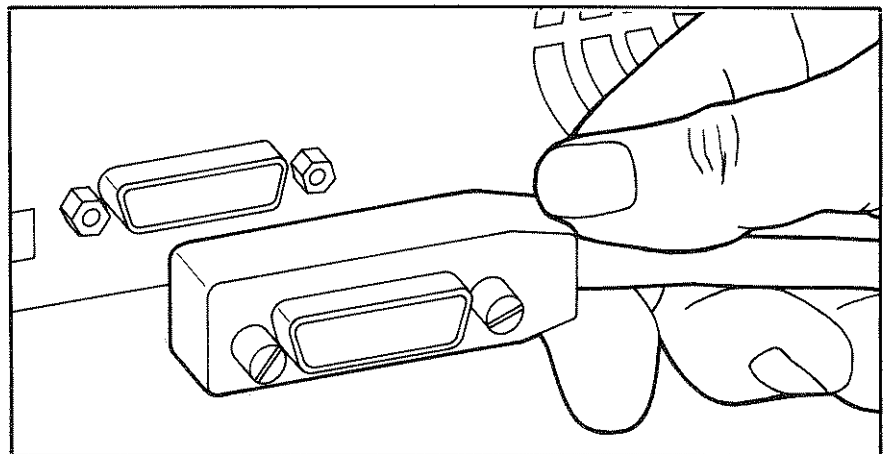
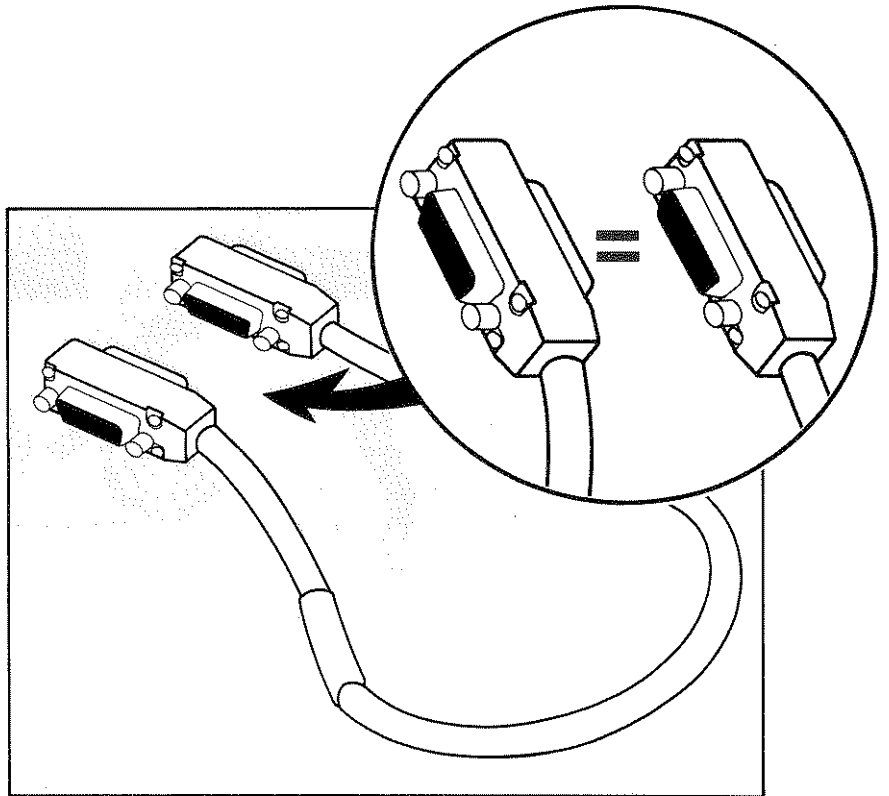
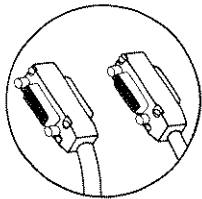

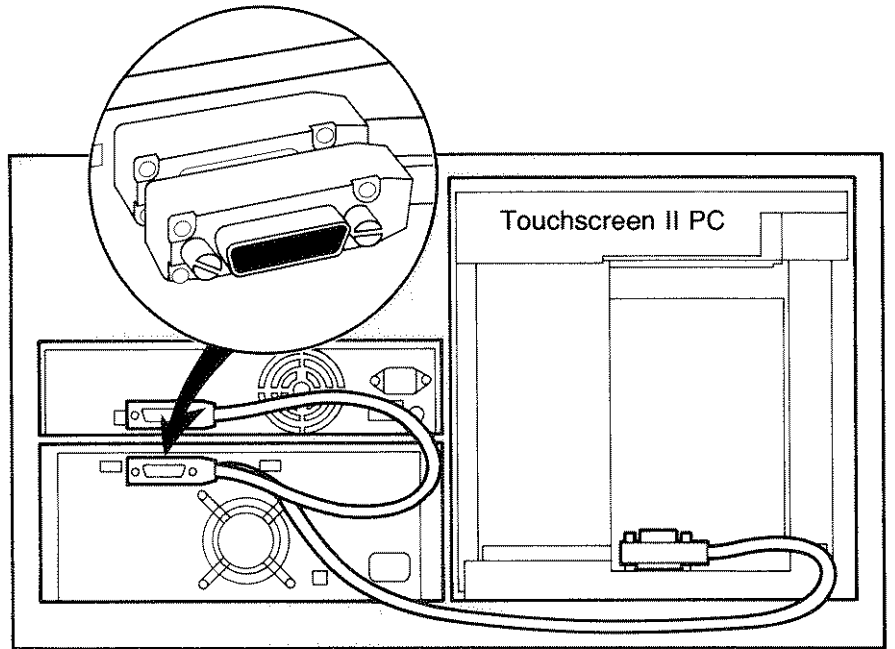
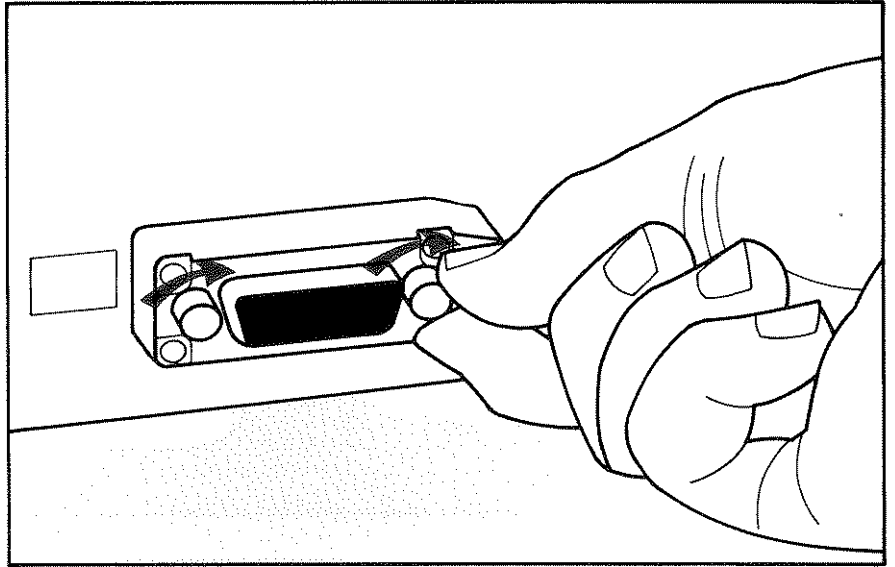
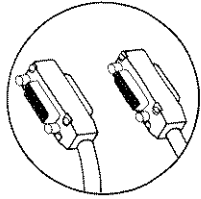

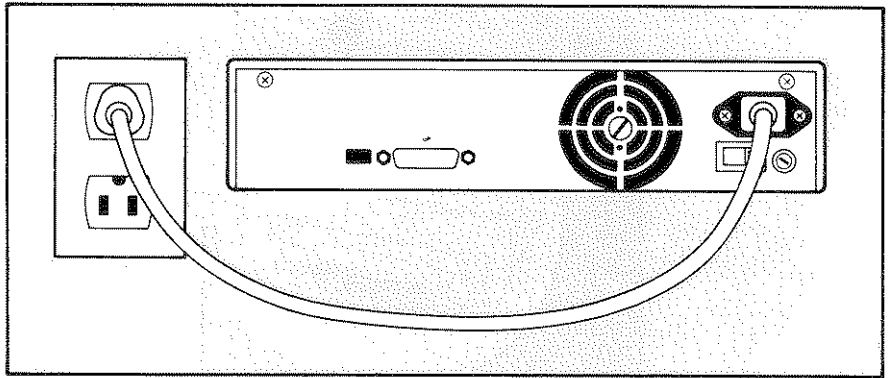
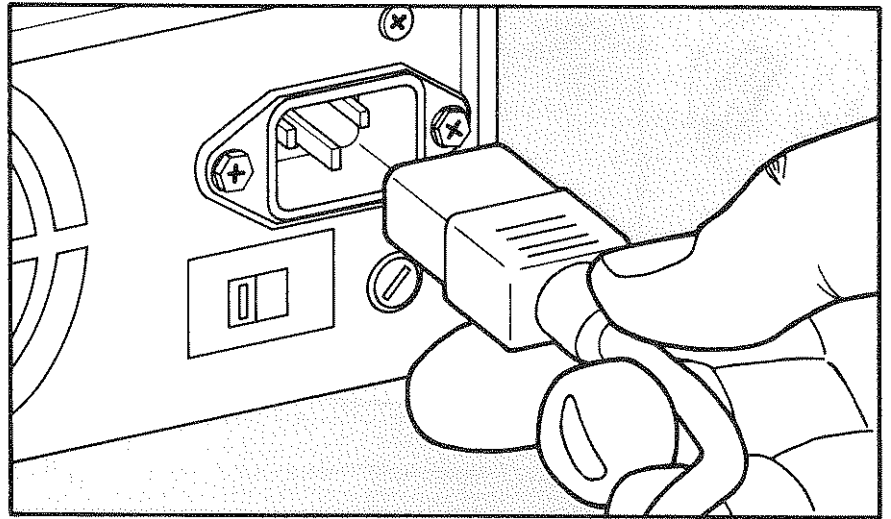
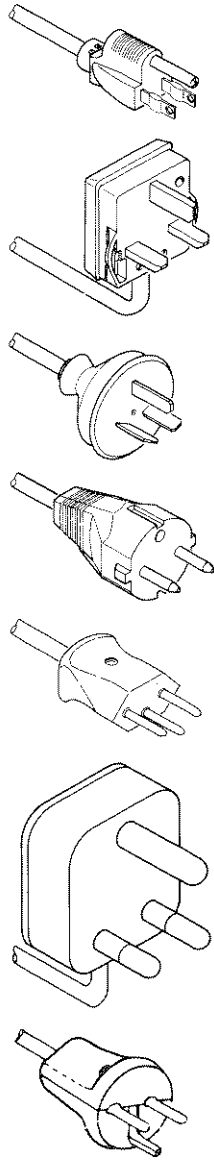



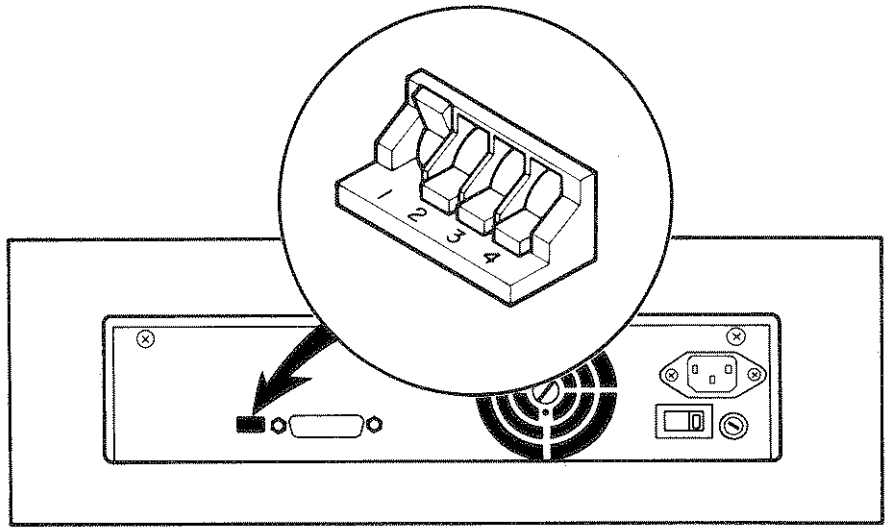
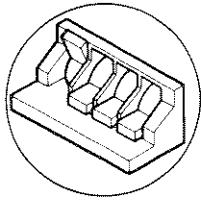



A power-on selftest is performed when you turn on your disc drive. If the fault light remains lit after 16 seconds, the disc drive has not passed the selftest.

Un autotest de mise en route se déclenche à la mise sous tension de l'unité de disques. Si, après 16 secondes, le voyant lumineux reste allumé, l'unité de disques n'a pas passé l'autotest.

Beim Einschalten des Geräts wird automatisch ein Selbsttest durchgeführt. Leuchtet die Fehleranzeige für mehr als 16 Sekunden auf, verlief der Selbsttest nicht erfolgreich.

Cuando se enciende la unidad impulsora de disco se efectúa automáticamente una autopruueba de la unidad. Si la luz indicadora de falla permanece encendida después de transcurridos 16 segundos, ello significa que la unidad no ha pasado la autopruueba.

Una prova di autocontrollo all'accensione viene eseguita quando inserite la vostra unità disco. Se il segnale luminoso di guasto rimane acceso dopo 16 secondi, l'unità disco non ha superato il test diagnostico.

Når disk driven aktiveres, udfores der samtidigt en kontrol af "Power-on". Hvis kontrollampen forbliver tændt mere end 16 sekunder, har disk driven ikke bestået kontrollen.

Een zelftest wordt uitgevoerd wanneer U Uw disk drive aanzet. Indien het storingslicht langer dan 16 seconden blijft branden, is de zelftest van Uw disk drive niet geslaagd.

Kone suorittaa automaattisen virrantarkastuskokeen, kun kytket virran levyasemaan. Mikäli virhevalo on edelleen päällä 16 sek. Jälkeen, tiedät, ettei levyasema läpäissyt tarkastuskoetta.

En "Power-on" kontrollprøve utføres samtidig som platedrevet blir slått på. Hvis feillyset fremdeles står på etter 16 sekunder, har platedrevet ikke bestått kontrollprøven.

Datorn utför ett självttest när du kopplar på din drivenhet för skivminne. Om felindikeringslampan fortasätter att lysa mer än 16 sekunder, kan självttestet inte fullbordas.

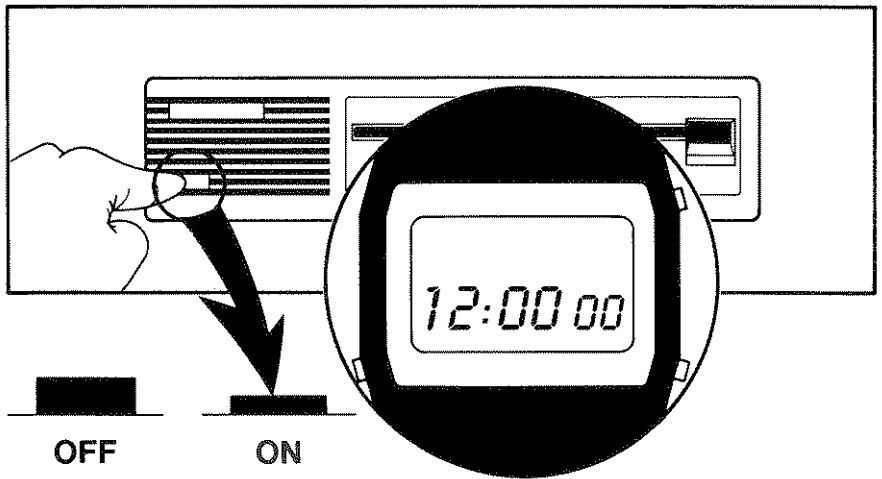

Pass  
Passe  
Bestehen  
Paso  
Superato  
Operational  
Geslaagd  
Läpäise  
Bestätt  
Fullbordat

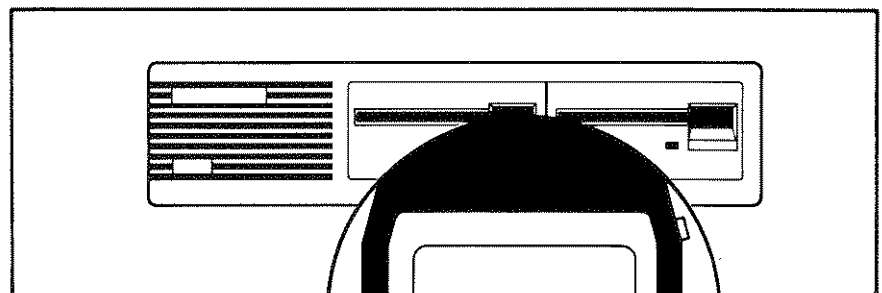

Fail  
Echec  
Versagen  
Fallä  
Bocciato  
Ikke operationel  
Niet geslaagd  
Epäonnistui  
Ikke bestätt  
Misslyckat

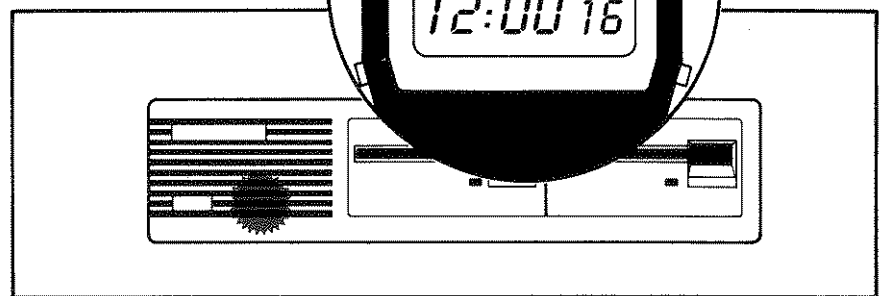

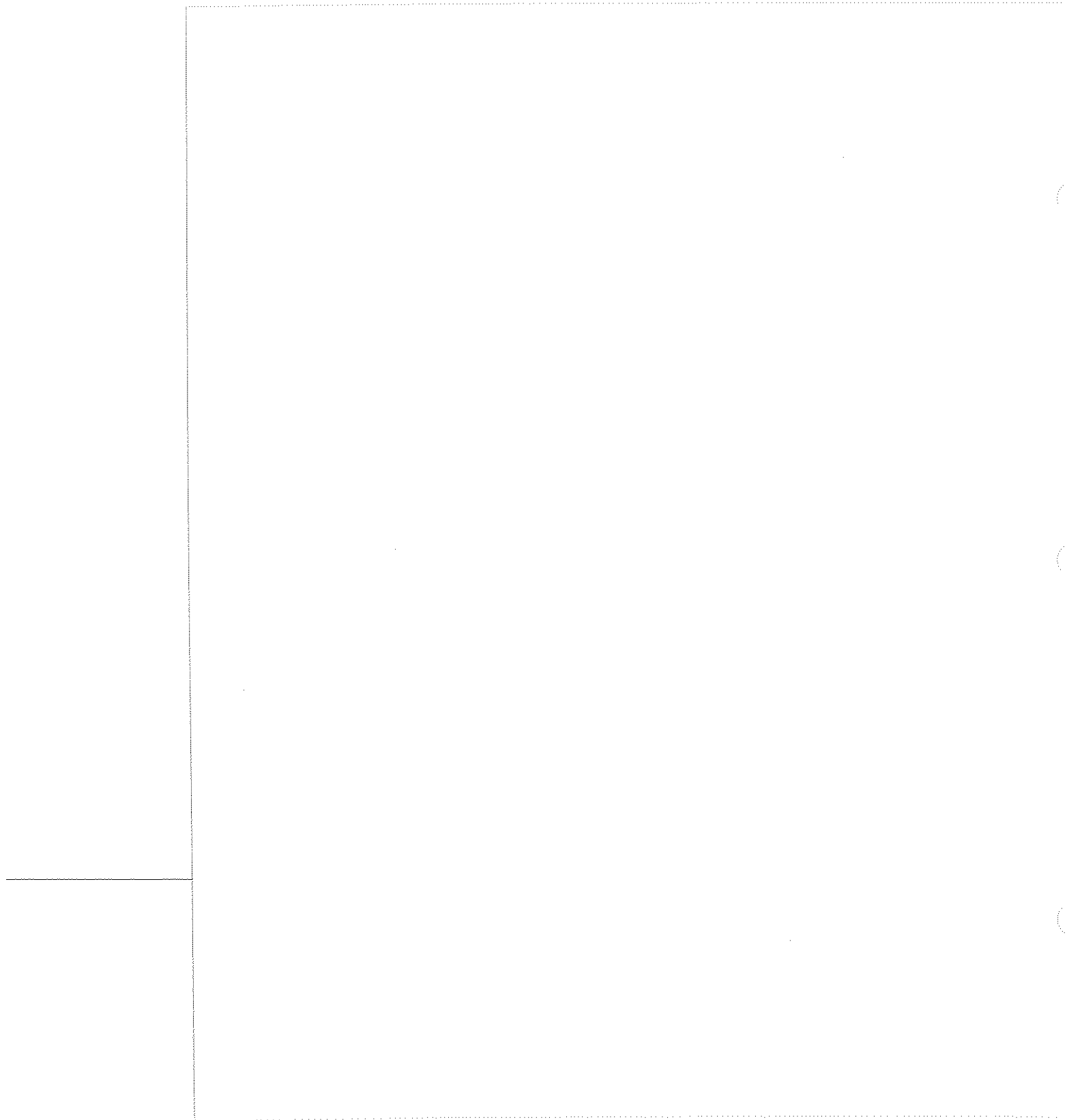

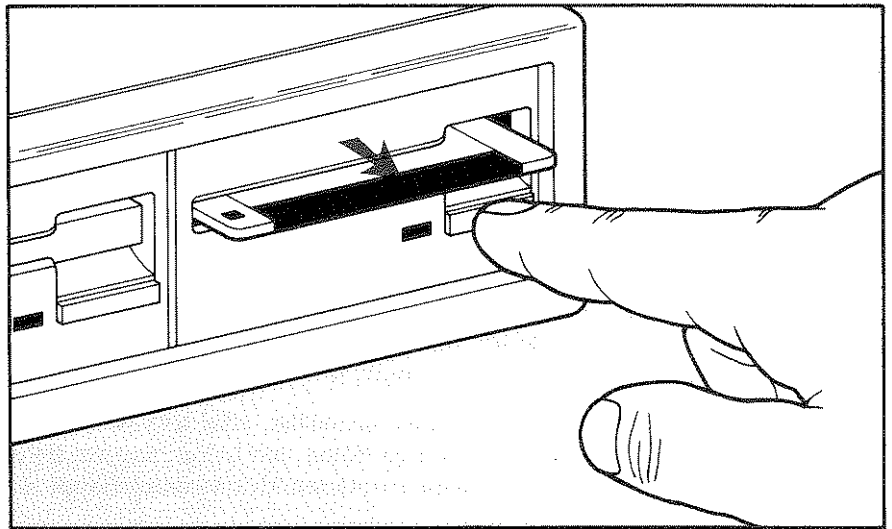
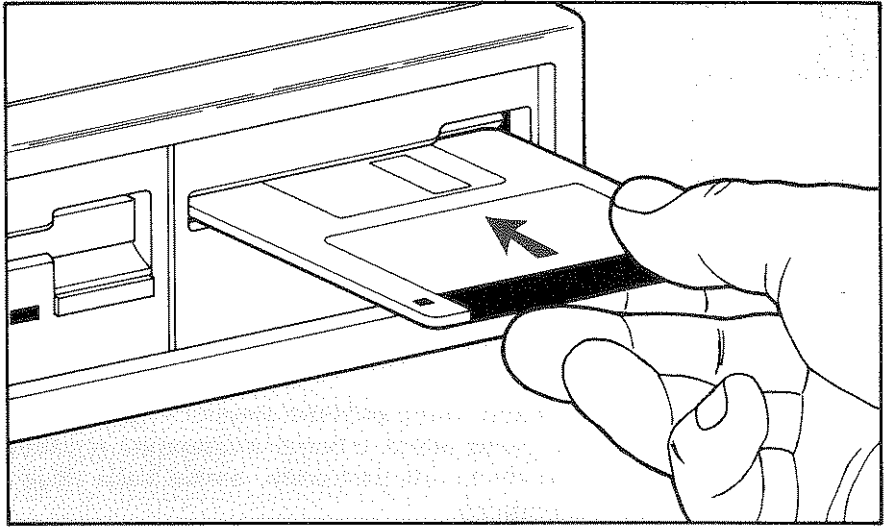
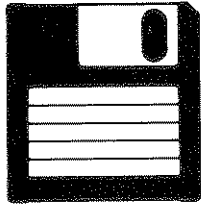

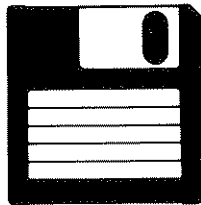

Write protecting ensures that the disc drive cannot change or delete information on the disc. To write protect a disc, slide the plastic write-protect button down.

La protección de l'enregistrement garantit que l'unité de disques ne peut altérer ou effacer les données enregistrées sur le disque. Pour mettre cette protection, il suffit de pousser le taquet en plastique prévu à ce effet sur le disque.

Der Schreibschutz verhindert das Ändern und Löschen der auf der Platte gespeicherten Information. Um eine Platte vor dem Überschreiben zu schützen, schieben Sie den Schreibschutzknopf nach unten.

La protección contra escritura asegura el que la unidad impulsora de disco no podrá alterar o borrar información registrada en el disco. Para poner en efecto esta protección, deslice hacia abajo el botón de plástico correspondiente.

La protezione contro la sovrascrittura assicura che l'unità disco non può cambiare o cancellare informazioni sul disco. Se volete proteggere un disco contro la sovrascrittura, mettete una linguetta di protezione contro la sovrascrittura nella scanalatura di protezione contro la sovrascrittura.

Skrivebeskyttelsen sikrer, at disk driven ikke kan ændre eller slette information på disketten. For at opnå skrivebeskyttelse af en diskette skubbes skrivebeskyttelsesknappen ned.

Schriftbescherming verzekert U ervan dat de disk drive geen gegevens op de disk kan veranderen of uitwissen. Indien U schriftbescherming wilt toepassen op een disk, dient U de plastic schriftbeschermingstoets naar beneden te schuiven.

Kirjoituksen soujaus varmistaa, ettei levyasema muuta tai poista levykkeelle talletettua tietoa. Jos haluat suojata levykkeellä olevan kirjoituksen, siirrä muovinen kirjoitussuojanappi alas.

Skrivebeskyttelse forsikrer at platedrevet ikke kan forandre eller utviske informasjonen på magnetplaten. For å skrivebeskytte en magnetplate, la skrivebeskytterknappen gli ned.

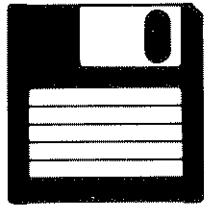

Skrivskydda-funktionen förhindrar att en drivenhet för skivminne inte ändrar eller tar bort information på disketten. För att skrivskydda en diskett, skjut plastknappen ner.

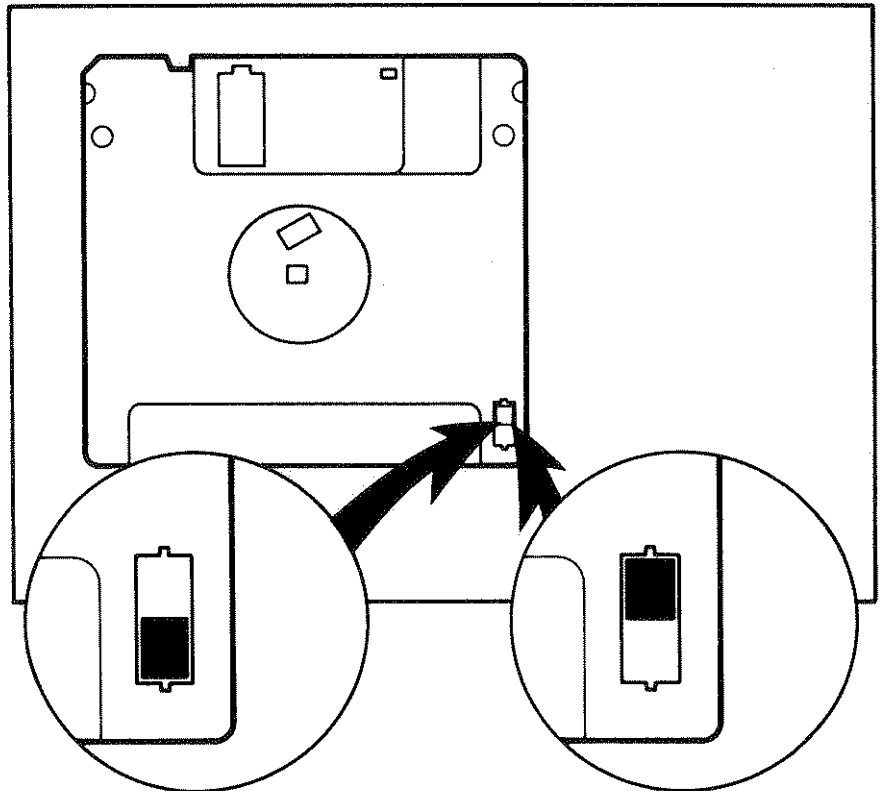

WRITE PROTECTED

PROTÉGÉ

SCHREIBGESCHÜTZT

PROTEGIDO CONTRA ESCRITURA

PROTETTO CONTRO LA SOVRASCRITTURA

SKRIVEBESKYTTET

SCHRIFTBESCHERMD

KIRJOITUSSUOJATTU

SKRIVEBESKYTTET

SKRIVSKYDDAD

NOT WRITE PROTECTED

NON PROTÉGÉ

NICHT SCHREIBGESCHÜTZT

NO PROTEGIDO CONTRA ESCRITURA

NON PROTETTO CONTRO LA SOVRASCRITTURA

IKKE SKRIVEBESKYTTET

NIET SCHRIFTBESCHERMD

EI KIRJOITUSSUOJATTU

IKKE SKRIVEBESKYTTET

ICKE SKRIVSKYDDAD

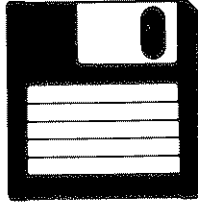

The Media Monitor automatically monitors the condition of each flexible disc. When the flexible disc access light begins blinking continuously even after the disc has been accessed, copy the disc you are using.

Le Moniteur de Média surveille l'état de chacun des disques que vous utilisez. Si le témion d'accès au disque clignote ou si vous entendez un cliquetis, copiez immédiatement le disque que vous êtes en train d'utiliser.

Der Medienmonitor überwacht die Abnutzung jeder einzelnen Diskette. Kopieren Sie die Diskette, wenn die Zugriffsanzeige zu blinken beginnt und ein tickendes Geräusch zu hören ist.

El Monitor de Discos vigila automáticamente el uso de cada disco individual. Cuando la luz de acceso de disco flexible comienza a parpadear y se escucha un sonido de clics, copie el disco que esté utilizando.

Il Controllo del Supporto (Media Monitor) controlla automaticamente l'uso di ogni disco individuale. Quando il segnale luminoso di accesso al disco flessibile comincia a lampeggiare e si sente un ticchettio, copiate il disco che state usando.

Media monitoren overvåger automatisk brugen af hver enkelt diskette. Når adgangsløset for den fleksible diskette begynder at blinke og der samtidigt høres en klikkende lyd, kopier da den diskette der benyttes.

De Media Monitor kontroleert automatisch het gebruik van iedere afzonderlijke disk. Wanneer het flexibele disk toevoerlicht begint te knipperen en U een getik hoort, dient U de disk die U gebruikt te kopiëren.

Media Monitor ohjaa automaattisesti jokaisen levykkeen käyttöä. Kun levykemerkkivalo alkaa vilkkua ja kuulet naksahduksen, kopioi käyttämäsi levyke.

Media Monitor overvåker automatisk bruken av hver enkel magnetplate. Når adgangsløset til den fleksible magnetplaten begynner å blinke og en klikkende lyd blir hørt, kopier magnetplaten som brukes.

Media Monitorn kontrollerar automatiskt användning av varje individuell diskett. När en indikeringslampa börjar blinka och du hör ett knäppande ljud, bör du kopiera disketten som du använder.



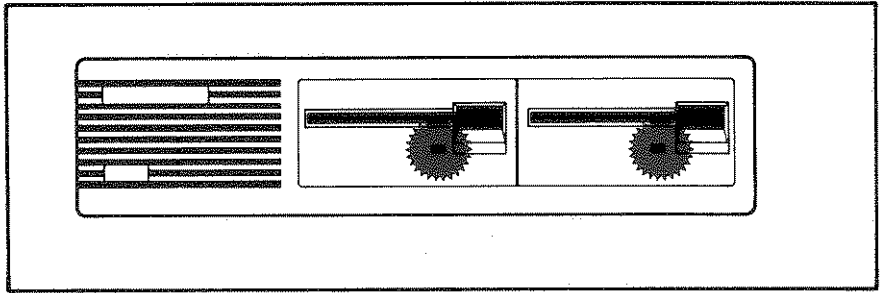
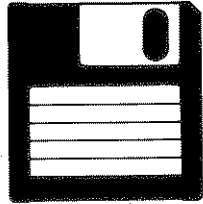

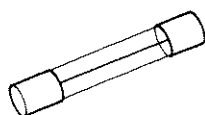

**WARNING**

Because of a potential shock hazard, always unplug the power cord if you need to change a fuse. Put the fuse in the fuse-holder, and then put the fuse-holder back into the drive.

Au moment de changer un fusible, débranchez toujours le cordon d'alimentation, pour ne pas risquer de recevoir une décharge électrique. Insérez le fusible dans le porte-fusible, puis replacez l'ensemble dans l'unité de disques.

Da die Gefahr besteht, einen Stromschlag zu erhalten, ziehen Sie das Stromkabel aus der Steckdose, bevor Sie die Sicherung auswechseln. Setzen Sie die Sicherung zuerst in den Sicherungsschalter ein und dann in den Sicherungskasten.

Para evitar el peligro de electrocución, desenchufe siempre el cordón de alimentación antes de reemplazar un fusible. Coloque el fusible en el portafusible y luego coloque éste en la unidad de disco.

Per evitare il possibile rischio di una scossa elettrica staccate sempre il cavo di alimentazione se dovete cambiare un fusibile. Mettete il fusibile nel porta-fusibili e poi rimettete il porta-fusibili nell'unità disco.

Træk – på grund af risiko for elektrisk stød – altid stikket ud, hvis det er nødvendigt at skifte sikring. Anbring sikringen i sikringsholderen og sæt derpå denne tilbage i disc-aktivatoren.

Om schokgevaar te voorkomen dient U altijd eerst de stekker uit het stopkontakt te verwijderen indien U een zekering moet vervangen. Plaats de zekering in de zekeringsdoos en plaats de zekering weer in de disk drive.

Mahdollisen sähköiskuvaaran takia on liitäntäjohdin irroitettava aina ennen sulakken vaihtamista. Pane sulake sulakkeenpitimeen ja aseta sulakkeenpidin takaisin levyasemaan.

På grunn av eventuell fare for stød, trekk alltid ut den strømførende ledningen, hvis De må skifte sikring. Sett sikringen inn i sikringsbeholderen og sett så sikringsbeholderen tilbake i disc-driven.

På grund av ev. stötfara, försäkra dig om att nätsladden är frånkopplad, om du behöver byta en säkring. Sätt säkringen i säkringshållaren och sätt sedan säkringshållaren tillbaka i drivenheten för skivminne.

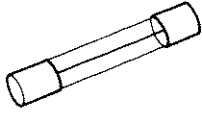

**WARNING**

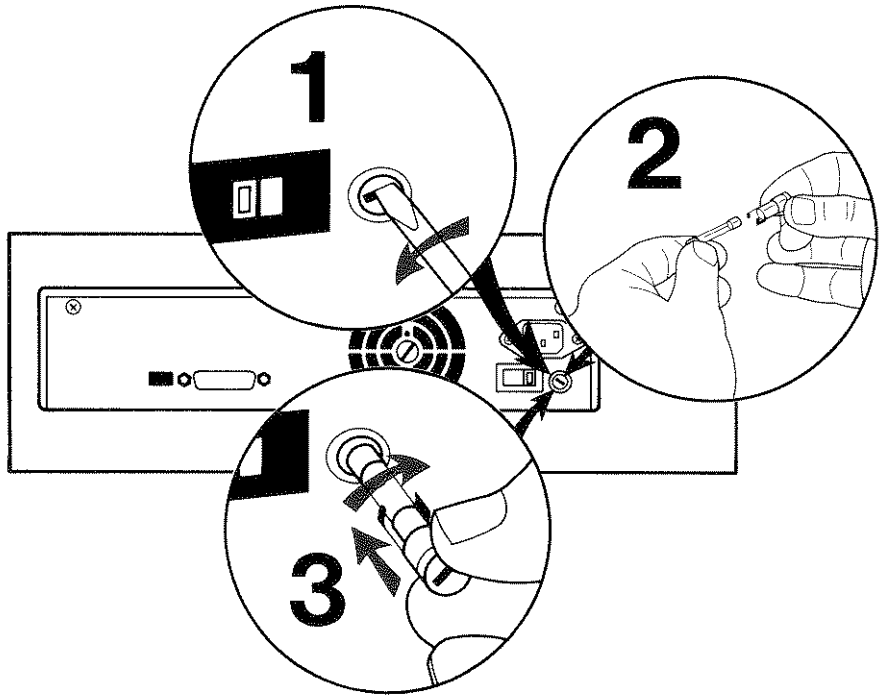

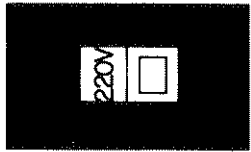
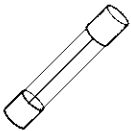
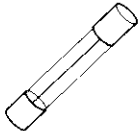
	
 1.0 AF 250V~	 .5 AF 250V~



## Reference Section

### Table of Contents

---

#### Chapter 1

##### Introduction

- 1-1 About This Manual
- 1-2 About Your Disc Drive

#### Chapter 2

##### Setting Up

- 2-2 Step 1: Before You Begin
- 2-3 Step 2: A Look at Your Disc Drive
- 2-4 Step 3: Setting the Voltage Switch
- 2-6 Step 4: Connecting the Interface Cable
- 2-7 Step 5: Connecting the Power Cord
- 2-8 Step 6: Setting the Address
- 2-9 Step 7: Try It!
- 2-10 Using Your Disc Drive

#### Chapter 3

##### Using Flexible Discs

- 3-1 A Look at the Flexible Disc
- 3-3 Loading the Disc
- 3-4 The Media Monitor
- 3-4 Single-Sided and Double-Sided Discs
- 3-6 Handling the Disc
- 3-7 Labeling the Disc
- 3-8 Ordering Discs

---

## **Chapter 4**

### **Problem Solving, Repairs, and Supplies**

- 4-1 Caring for the Case
- 4-1 Warranty
- 4-2 Maintenance
- 4-2 Changing the Fuse
- 4-3 What If Something Goes Wrong?
- 4-6 How to Order Supplies

## **Appendix**

### **Technical Reference**

## **Glossary**

## **Index**

# 1

## Introduction

### About This Manual

If you've gotten this far, you've probably skipped all of those pictures or have gotten through them and are wondering what to do next--or aren't quite sure what you've just done.

**If you'd like a little more detail**, read on. This section of the manual elaborates on the contents of Part I and describes flexible discs as well as basic maintenance and troubleshooting. When you're finished, the disc drive or peripheral section of your computer manual should describe your next step.

**If you're confident about setting up your system and are ready to start using it**, read the disc drive or peripheral section of your computer manual.

**If you're connecting this drive to an HP Vectra PC**, you must also order an HP 88500A Interface. This Interface Package includes a manual with installation and operating information.

Keep this manual for reference. It's punched so you can insert it into a three-hole book such as your computer manual binder.

---

## About Your Disc Drive

A disc drive is a device that allows a computer to read data stored on a disc or write data to a disc. A disc is similar to a phonograph record that stores programs and data instead of music. Data may be stored on only one side of a disc (single-sided) or on both sides of the disc (double-sided).

The **HP 9122S** has one flexible disc drive, and the **HP 9122D** has two flexible disc drives. Both drives use 3 1/2-inch, double-sided, flexible discs. *Chapter 3* describes the care and use of flexible discs.

Let's set up your new disc drive.



# 2

## Setting Up

You'll go through these seven steps in this chapter:

- Step 1: Before You Begin
- Step 2: A Look at Your Disc Drive
- Step 3: Setting the Voltage
- Step 4: Connecting the Interface Cable
- Step 5: Connecting the Power Cord
- Step 6: Setting the Address
- Step 7: Try It!

If you've already set up your drive and want to start using it, move now to the disc drive or peripheral section of your computer manual. Come back to this chapter if you have questions.

*Chapter 3* describes the care and use of flexible discs.

---

## Step 1: Before You Begin

- Hewlett-Packard supplies a power cord, two extra fuses with fuse inserts (one set for 115V operation and the other for 220V operation), one flexible disc, and this manual with your disc drive.
- 

### CAUTION

Although rugged, your disc drive is a precision instrument. Please use care when moving it.

---

1. Inspect your disc drive for any physical damage that may have occurred during shipment.
  2. If you find any damage, notify your dealer or the nearest Hewlett-Packard Sales Office and file a claim with the carrier.
- 

### CAUTION

3. Pull out the protective wedges in the flexible disc drive slots.
  4. *Fully* depress the eject buttons to remove the plastic shipping discs from the drive slots.
- 

5. If you plan to move the drive in the future, save the shipping carton and shipping discs and wedges. This shipping material is carefully designed to protect your drive from shock and vibration.

Before you move the drive, insert the shipping discs and wedges in the flexible disc drive slots. Seal the drive in a plastic bag and repack it in the shipping carton. If you'd like to order a new shipping disc and wedge, see *Chapter 4* for ordering information.

## Step 2: A Look at Your Disc Drive

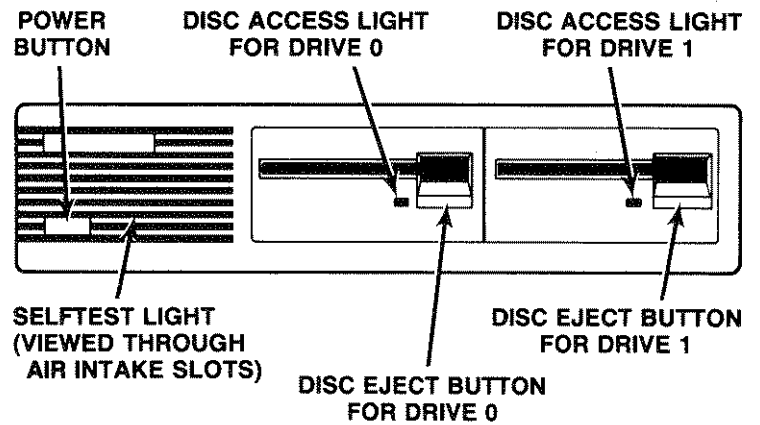

HP 9122D Front Panel

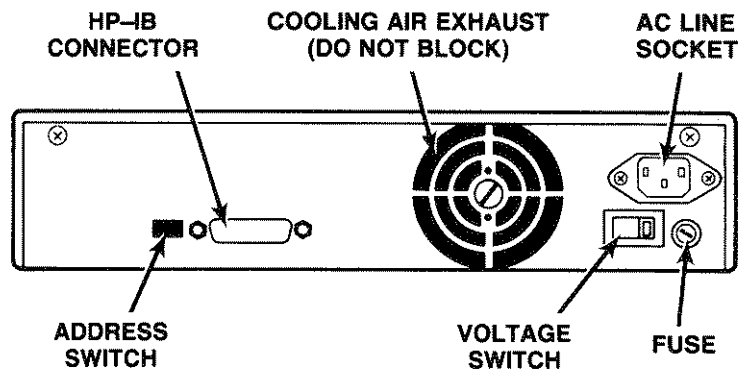

HP 9122D/S Rear Panel

Note the cooling air exhaust on the rear panel. When you position your drive, don't block this exhaust.

---

**NOTE**

Operate your HP 9122D/S in a clean environment to prolong its life. HP is not responsible for damages caused by use in a dirty environment.

---

Before we begin, find the power button on the front panel of your disc drive. The drive is on when the button is IN, and off when the button is OUT. *Perform the steps that follow with the drive off.*

### Step 3: Setting the Voltage

#### Voltages and Fuses

Voltage Setting	Nominal Range	Countries	Fuse	Fuse Holder
			P/N	
115V~	100-120V~	U.S. Mexico Canada Japan Most South American Countries	1.0 AF 250V~  HP P/N 2110-0001	Gray
220V~	200-240V~	Most European Countries	.5 AF 250V~  HP P/N 2110-0605	Black

A fuse was installed in your disc drive at the factory, and you normally do not need to change it. If you do need to change it, follow the instructions in *Chapter 4*.

---

**CAUTION**

To avoid damaging the drive, make sure the drive is off before changing the voltage setting.

---

1. Find the voltage switch on the rear panel of your disc drive.
2. Make sure the voltage switch is set correctly. See the preceding chart to determine which setting is correct for your local power. (Figures are based on normal usage).
3. If necessary, use your fingernail or a small screwdriver to slide the voltage switch sideways until the switch displays the proper setting.

The following figure illustrates the power cords used with each voltage setting.

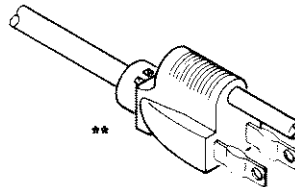
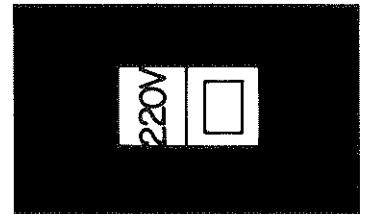
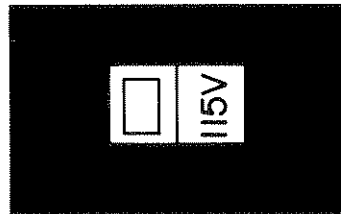

\*\*Peru allows use of this power cord at a voltage setting of 220V.

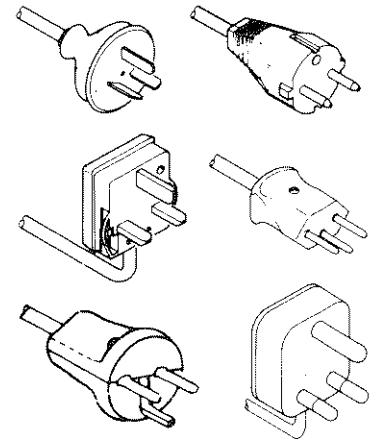

Voltage Setting and Power Cords

---

## Step 4: Connecting the Interface Cable

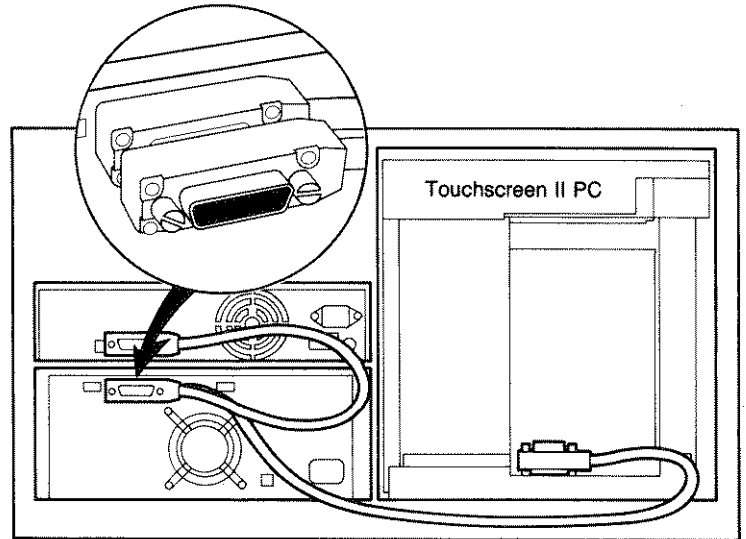

Interface Cable

---

### NOTE

Look at the inset in the above figure.

The end of the interface cable allows you to connect, or "piggyback," other cables. If you need to add another peripheral, you can plug another interface cable into the back of the cable you have just hooked up. We recommend, however, that no more than four piggyback connectors be stacked on one piece of equipment; the resulting weight could damage the connector mounting.

Refer to the *Appendix* for more details on interface restrictions.

- 
1. Make sure your disc drive and computer are turned off.

---

### Step 5: Connecting the Power Cord

2. Attach one end of the interface cable onto the HP-IB connector of your disc drive, and tighten the screws on the cable with your fingers.
3. Attach the other end of the cable onto the HP-IB connector of your computer, and tighten the screws on the cable with your fingers.

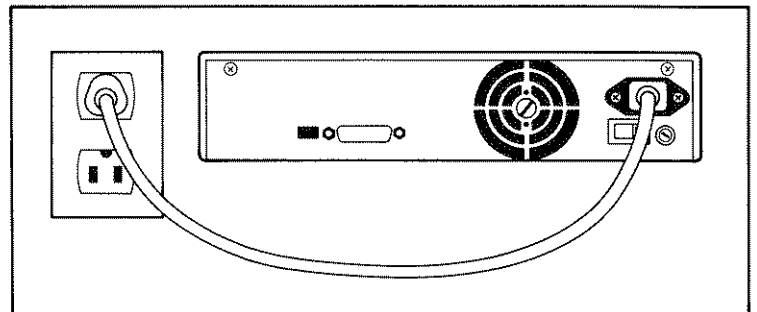

Power Cord Connection

#### **WARNING**

This product is equipped with a power cord and plug designed for your safety. Plug the power cord into a properly grounded receptacle to avoid possible electrical shock.

1. Make sure that your disc drive and computer are turned off.
2. Connect the power cord to the socket labeled "AC LINE" on the rear panel of your disc drive.
3. Plug the power cord into a socket.

## Step 6: Setting the Address

Each Hewlett-Packard peripheral connected to your personal computer must have a unique address, just as each house on a block must have a unique address. Your computer uses that address to contact the peripheral to retrieve or send information.

Hewlett-Packard sets your disc drive address to 0 at the factory. Each time you turn your system on, the computer will load the operating system from the HP 9122D/S at this address. (You probably do not need to change this address unless you have another flexible or hard (fixed) disc drive set to address 0.)

The address switches can be set to any one of eight addresses, ranging from 0 through 7. As illustrated in the following figure, the address is set by flipping the four small switches "up" or "down." (Think of your light switches at home: when the switch is at the top, it is "up"; when the switch is at the bottom, it is "down.")

Address Switch Settings

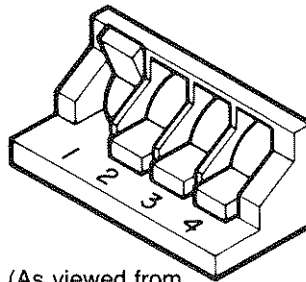

(As viewed from the rear panel)

Address	Switch Positions			
	Left	Middle Left	Middle Right	Right
0	Up	Down	Down	Down
1	Up	Down	Down	Up
2	Up	Down	Up	Down
3	Up	Down	Up	Up
4	Up	Up	Down	Down
5	Up	Up	Down	Up
6	Up	Up	Up	Down
7	Up	Up	Up	Up

If you need to change the address:

1. Make sure the drive is turned off.
2. Using the figure above, flip all switches to the positions corresponding to the address desired.



---

From now on, whenever you change the address, you must turn the drive off and then on again for your system to know that a change has occurred.

You'll turn the drive on and learn about the drive's selftest in the next step.

### Step 7: Try It!

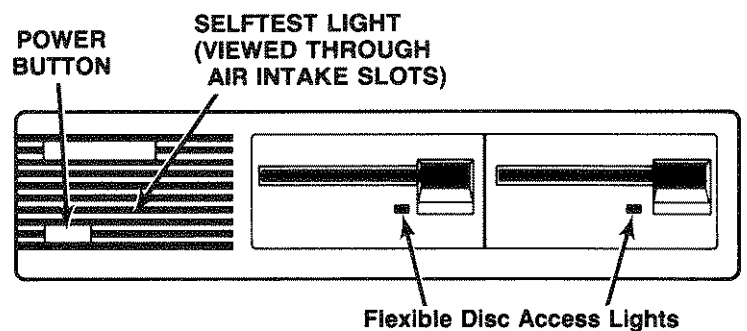

Power Button and Selftest Light

---

### CAUTION

Do not press the disc eject button or turn off your disc drive when the disc access light on the front panel is on. The disc access light is on when your computer is storing data to, or retrieving data from, the disc. It is lit momentarily when the drive is turned on and when a new disc is inserted.

- 
1. Locate the power button on the front panel of your disc drive. Push the button IN to turn on the drive.
  2. When you turn on your disc drive, it performs a selftest which takes about 3 to 16 seconds.  
A red light is visible though the air intake slots on the front panel during selftest.

3. After 3 to 16 seconds, the selftest light should go out, indicating that your disc drive has passed the selftest.
4. If the red fault light remains on, turn off your disc drive. Turn your disc drive on again to repeat the selftest.
5. If the fault light is still on after you repeat the selftest, contact your dealer or the nearest Hewlett-Packard Sales Office.

## Using Your Disc Drive

Read on to learn about flexible discs (*Chapter 3*) and basic maintenance and troubleshooting (*Chapter 4*).

For information on using your disc drive with your computer, refer to the disc drive or peripheral section of your computer manual.

# 3

## Using Flexible Discs

### A Look at the Disc

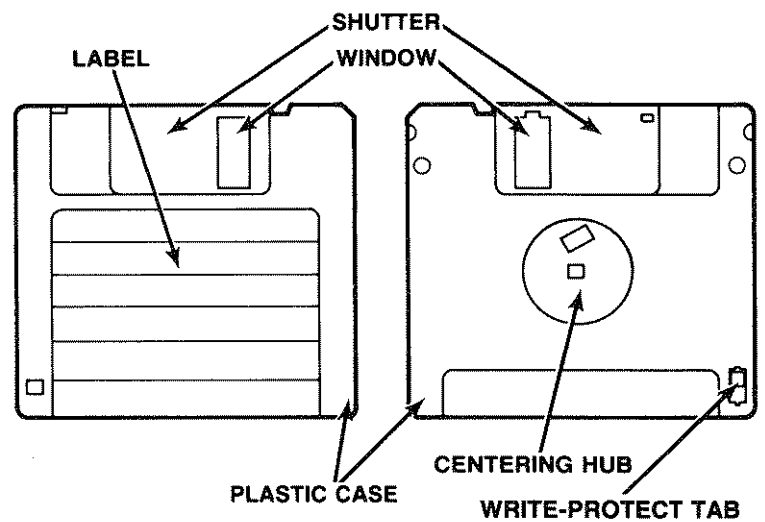

Parts of the Flexible Disc

### Window and Auto Shutter

Your disc drive reads data from the disc and writes data on the disc in the space beneath the window. The window is covered by a metal shutter.

When you place the disc in the drive, this shutter automatically opens to expose the disc surface. When you remove the disc from the drive, the shutter closes to protect the disc surface. Do not touch the disc surface or expose it to dust.

### Centering Hub

On the back of the plastic case is a round, metal center called the centering hub. The centering hub ensures accurate positioning when the disc is inserted in the drive.

### Write-Protect Tab

Write-protecting ensures that your disc drive cannot write over or delete information on the disc.

Write protect discs that contain valuable programs and data.

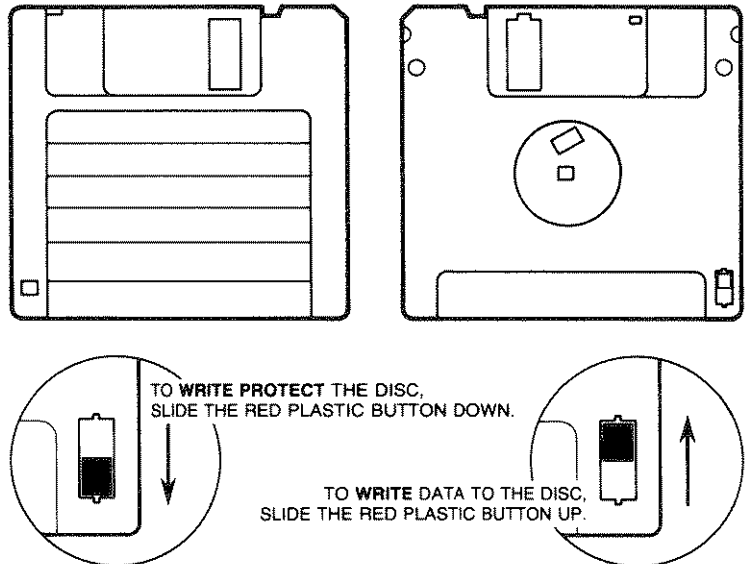

### Write-Protect Tab for Double-Sided Discs

If you want to write protect a double-sided Hewlett-Packard disc:

1. Place the tip of a pen in the small hole at the top of the write-protect tab.

2. Slide the tab downward until it locks into place.
3. If you no longer wish to write protect the disc, slide the tab up.

If you have a disc with the write-protect tab missing, the disc is write protected because the opening isn't covered.

## Loading the Disc

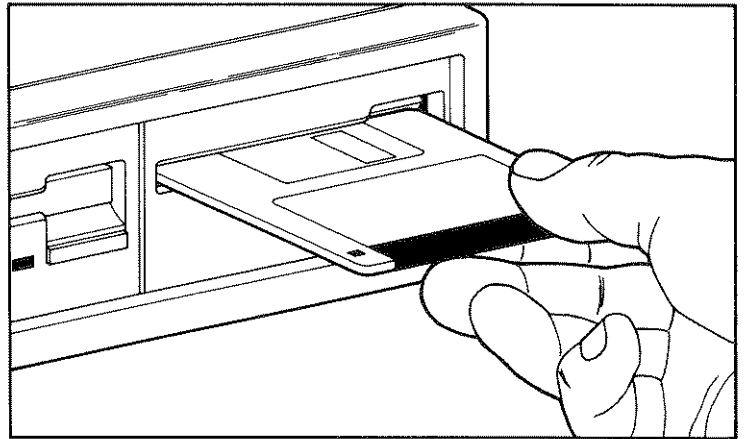

Loading the Disc

1. Insert the disc by holding the disc with the label on top and the shutter pointing at the slot in your disc drive.
2. Slide the disc completely into the drive until the disc clicks into place. The disc will drop about 1/4 inch. Do not force the disc.
3. Remove the disc by pressing the disc eject button. Pull the disc straight out of the drive.

## The Media Monitor

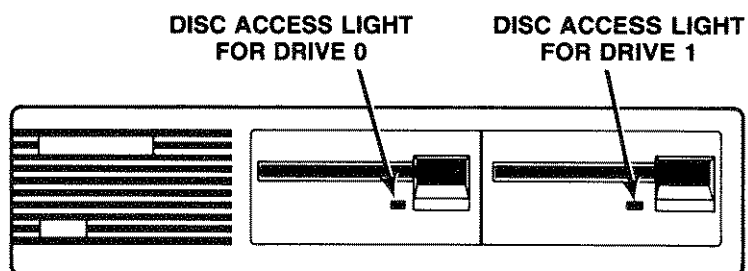

Flexible Disc Access Light

- The Media Monitor automatically checks how much the disc has been used. When there is any risk of losing data, the flexible disc access light on the front panel continues blinking even after the disc has been accessed.
- When this occurs, your disc drive still accepts and performs commands from the computer but will immediately resume the Media Monitor warning when the command has been performed.
- When you see the Media Monitor warning, copy the disc you are using as soon as possible. Begin using the copy and discard the original disc. If you continue to use the original disc, the drive will eventually write protect the disc. At that time, you will only be able to read data from that disc or copy it; you will not be able to store data on that disc.

## Single-Sided and Double-Sided Discs

The terms double-sided and single-sided can be confusing. Here's a glossary to help you understand how the terms are used.

Single-Sided Disc Drive: Has only one read/write head. Records data on only one side of a disc.

Double-Sided Disc Drive: Has two read/write heads. Records data on both sides of a disc.



- Single-Sided Disc: Data can be recorded on only one side of this disc. Hewlett-Packard single-sided discs are blue and are labeled "single-sided."
- Double-Sided Disc: Data may be recorded on both sides of this disc. HP double-sided discs are gray and are labeled "double-sided."
- Single-Sided Formatting: Prepares a disc for one-sided recording of data. You may format "single-sided" on either single-sided or double-sided discs.
- Double-Sided Formatting: Prepares a disc for two-sided recording of data. You can format "double-sided" ONLY on double-sided discs in a double-sided disc drive.

The HP 9122S and the HP 9122D record data on both sides of a flexible disc. The following chart elaborates on the recommended use of single-sided and double-sided discs. Words used in the chart are defined as follows:

*EXCHANGE ONLY* means that the discs should be used *only* for exchanging data and programs with single-sided disc drives and should not be used on a daily basis.

OK means that the discs may be used daily.

**Recommended Use of Discs**

Single-sided HP discs	EXCHANGE ONLY
Double-sided HP discs in single-sided format	OK
Double-sided HP discs in double-sided format	OK
HP software	OK

---

**CAUTION**

We recommend gray, double-sided Hewlett-Packard discs for daily use in an HP 9122S and an HP 9122D.

Both sides of a double-sided disc are treated with a lubricant that reduces wear on the read/write head. The unused side of a single-sided disc *is not* coated with this lubricant, so using a single-sided disc in a double-sided drive exposes the read/write head to an unprotected surface. While occasional use does not damage the read/write head, repeated use of single-sided discs in a double-sided drive can cause wear and eventual failure both to the discs and to the read/write head.

---

## Handling the Disc

Media Monitor and the flexible disc's plastic case and metal shutter make HP's 3 1/2-inch discs more reliable than comparable 5 1/4-inch products. However, because your discs contain valuable data and programs, you should treat your discs very carefully.

Follow these guidelines to avoid data loss and to prolong the life of both your flexible discs and your disc drive.

- Make sure the shutter is closed when the disc is not in use to protect the disc from dust, fingerprints, and scratches.
- Use the disc in a clean environment to avoid dust or dirt particles scratching the disc.
- Store discs in a cool, dry place to prevent moisture and heat damage.
- Avoid magnetic fields, such as appliances with motors, to prevent magnetically erasing the data on your discs.
- Don't touch the surface of the disc. Fingerprints contaminate the disc, shortening disc life and causing data loss.



## Labeling the Disc

- Don't try to clean the disc. The plastic case contains a mechanism for cleaning the disc surface, and other cleaning methods may damage the disc.

When you order boxes of discs, you receive a packet of labels with the discs. Position the label on the disc so that the colored portion of the label is folded over the lower edge of the disc. Write the name of the disc immediately beneath the colored edge of your disc, as shown in the following figure.

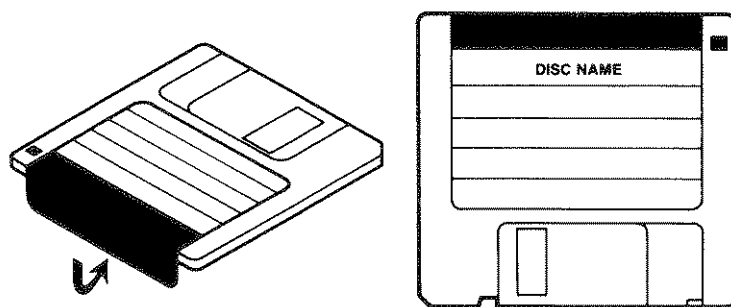

Positioning the Label

Note that the disc labels come in a variety of colors; you may choose to establish a color-coded system for cataloging your discs. For example, discs containing memos may be labeled in red while discs containing personnel files may have blue labels. Store your discs upright in a container so that the colored edge of the labels are visible. You may then use the colors to select the category of discs you desire, and then read the labels to select the specific disc needed.

---

## Ordering Discs

To order a ten-pack of gray, double-sided flexible discs, specify HP part number 92192A. Order the package from Hewlett-Packard Direct Marketing Division, 1320 Kifer Road, Sunnyvale, California 94086. Telephone (800) 538-8787 toll free in the U.S. or (406) 738-4133 in California.

---

### CAUTION

Disc drive performance and reliability are dependent on the type of media used. Disc drive specifications can be assured only when using HP media. The use of improper media can result in premature disc failure or damage to your disc drive.

On some disc products, HP may qualify other non-HP media. When tested, this media met HP specifications. However, HP does not warrant or support this media and cannot control changes in its specifications or quality. The selection and use of such products are the customer's responsibility. HP reserves the right to exclude from warranty and maintenance agreement coverage any repairs which HP reasonably determines or believes were caused by the use of media not provided by HP. HP will, upon request, provide such repairs on a time and material basis.

---

# 4

## Problem Solving, Repairs, and Supplies

---

### Caring for the Case

1. Before cleaning the case, disconnect the power cord and HP-IB cables. Make sure that all discs are removed from the flexible disc drive.
  2. Dampen a clean, soft, lint-free cloth in a solution of clean water and mild soap.
- 

#### CAUTION

Chemical spray-on cleaners used for appliances and other household and industrial applications may damage the case finish. Do not use cleaners that contain ammonia, benzenes, chlorides, or abrasives.

---

3. Wipe the soiled areas of the case, making sure that no cleaning solution gets inside the case. For cleaning more heavily soiled areas, use a solution of 80% clean water and 20% isopropyl alcohol.
4. Wipe the areas with cleaning solution with another clean, soft, lint-free cloth. Remove pen and pencil marks with a non-abrasive eraser.

### Warranty

A warranty summary for the U.S. is included in the front of this manual. If you have questions concerning the warranty, please contact the nearest Hewlett-Packard Sales Office. In countries other than the U.S., contact your dealer or the nearest HP Sales Office to determine warranty terms.

## Maintenance

Your disc drive does not require regular maintenance. However, the performance and life of your disc drive and flexible discs depend on how carefully they are handled. Be sure to follow the disc care and handling guidelines presented in *Chapter 3* and the environmental restrictions presented in the *Appendix*.

## Changing the Fuse

A new fuse was installed in your disc drive at the factory. Should you need to change the fuse, follow these guidelines and steps carefully.

### WARNING

To avoid a potential shock hazard, turn off and unplug your drive if you change a fuse. Place the fuse into the fuse holder and then into the unit.

For continued protection against fire hazard, replace the fuse only with the same type and rating fuse.

### Voltages and Fuses

Voltage Setting	Nominal Range	Countries	Fuse P/N	Fuse Holder
115V~	100-120V~	U.S. Mexico Canada Japan Most South American Countries	1.0 AF 250V~  HP P/N 2110-0001	Gray
220V~	200-240V~	Most European Countries	.5 AF 250V~  HP P/N 2110-0605	Black

## What If Something Goes Wrong?

1. Turn off and unplug your drive.
2. Use a screwdriver to turn the fuse holder in a counter-clockwise direction while pushing in gently.
3. When you have loosened the fuse holder, pull it out with your fingers.
4. Remove the old fuse.
5. Put the new fuse into the fuse holder, and then insert the fuse holder into the unit. Do not hold the metal portion of the fuse while inserting the fuse into the unit. Turn the fuse holder in a clockwise direction while pushing gently.

- **What if the flexible disc access light begins blinking when the flexible disc isn't being accessed?**

The blinking of the flexible disc access light is a feature of your disc drive called the Media Monitor. This warning indicates that the flexible disc you are using should be replaced. As soon as possible, copy the worn disc and discard it. For further information about the Media Monitor, please read the "Media Monitor" section in *Chapter 3*.

- **What if the fault light remains on after the selftest?**

If your disc drive does not pass the selftest, take the following actions:

1. Turn off the drive, then turn it back on and wait for it to repeat the selftest.
2. If the drive fails again, check the temperature and humidity of the environment in which you use the drive. Make sure you are using your drive in an area that matches the environmental specifications in the *Appendix*.

Your disc drive may have experienced abrupt temperature or humidity changes. For example, an abrupt change in temperature occurs when you take your drive out of an air-conditioned office,

take it to a warm car, and then set it up in another air-conditioned office. *If your drive has been moved from one type of environment to another, allow the drive to stabilize in the new area for two hours before turning it on.* If you turn the drive on without allowing it to stabilize, it may fail the selftest.

3. If your disc drive still fails the selftest, contact your dealer or the nearest HP Sales Office.

■ **I get an error stating that the disc is write protected. What should I do?**

1. You may be using a disc that you have write protected. If you wish to write information on the disc, reverse the write-protect tab on the disc (see *Chapter 3*). If you wish to keep the disc write protected, insert another disc.
2. Also, the disc may have been automatically write protected by the Media Monitor. If the Media Monitor warning is on, copy the information to a new disc and discard the old disc.
3. If you still receive a write-protect error, try another disc. If you receive a write-protect error on several discs in a row, your disc drive may not be operating properly. Contact your dealer or HP Sales Office.

■ **What should I do if I get a message that says, *Disc Not Present or No Discs Were Found*?**

1. Be sure your disc drive is turned on.
2. Make sure all power cables are securely connected.
3. Be sure that you have a disc inserted in the drive and that the disc has been initialized (formatted).
4. Check that your disc drive is addressed correctly.
5. If all this fails, you may have a bad flexible disc. Try another flexible disc.

6. If this disc fails, turn your disc drive off and then back on. If you continue to get this message, contact your dealer or HP Sales Office.

■ **What if I get an error message saying, *Disc Error Reading Drive \_\_\_\_\_*?**

1. Your flexible disc is probably worn or damaged. Try using other discs to see if you get the same message.
2. If you receive the message on only one flexible disc, copy the disc immediately and discard it. (Please note that if the disc is worn or damaged, the copy may not work.)
3. If this fails, turn your disc drive off and then back on. If you continue to receive this message on several flexible discs, contact your dealer or HP Sales Office.

■ **What should I do if I get a message that says, *Disc drive is empty, off, or undefined?***

1. Be sure your disc drive is turned on.
2. Check that all power cables are securely connected.
3. Be sure that you have a disc in your flexible disc drive.
4. Check that your disc drive is addressed correctly.
5. If all this fails, you may have a bad flexible disc. Try another disc.
6. If this too fails, turn your disc drive off and then back on. Contact your dealer or HP Sales Office if you continue to get this message.

*Your disc drive can be repaired only by a trained service person. If you suspect that your disc drive is malfunctioning, contact your dealer or the nearest HP Sales Office.*

## How to Order Supplies

DESCRIPTION	HP PART NUMBER
Gray Double-Sided Flexible Discs (10 discs/box)	92192A
Fuse, 1.0 AF 250 V (115V Setting)	2110-0001
Fuse, .5 AF 250 V (220V Setting)	2110-0605
Power Cord*	See footnote
HP-IB Cable, 1-meter length	10833A
HP-IB Cable, 2-meter length	10833B
HP-IB Cable, 0.5-meter length	10833D
Shipping Disc and Wedge	
Disc	1535-4881
Wedge	9223-0648
HP 9122D/S User's Manual	09122-90020

\* Power cords are dependent on your location. Please consult your dealer or HP Sales Office if you need to order a power cord.

Order supplies for your disc drive by contacting your dealer or HP Sales Office. You may also contact the Hewlett-Packard Direct Marketing Division at the following address:

Direct Marketing Division  
1320 Kifer Road  
Sunnyvale, California 94086

Telephone: (800) 538-8787 toll free in the United States  
(406) 738-4133 in California



## Appendix: Technical Reference

### HP-IB Interface Restrictions

- The total length of cable in one bus system must be *less than or equal to* two meters times the number of devices connected to your system (maximum cable length  $\leq$  two meters  $\times$  the number of devices). Your computer counts as one device, and the total length of cable must not exceed 20 meters.

Here's an example:

You have a total of three devices.  $2 \text{ meters} \times 3 \text{ devices} = 6 \text{ meters}$ . Your system can be connected together with cables that have a total length less than or equal to 6 meters.

- The individual lengths of cable may be arranged in any manner, as long as the total length does not exceed the maximum. If you are going to connect more than ten devices together, use cables shorter than two meters between the devices to keep the total cable length less than 20 meters.
- The maximum number of devices that you may connect together in one bus system is 15. Up to eight of these devices may be disc drives. There are no restrictions on the way cables may be connected together. We recommend, however, that no more than *four* piggyback connectors be stacked on one device since the resulting weight could damage the connector mounting.

## Specifications

Listed below are the performance characteristics, environmental ranges, physical characteristics, and power requirements for the HP 9122D/S disc drives.

### Performance Characteristics\*

#### Formatted Capacity

##### Bytes per Unit:

	Single-Sided Format	Double-Sided Format
256 Bytes/Sector	270k	631k
512 Bytes/Sector	---	710k
1024 Bytes/Sector	---	788K

#### Sectors per Track

256 Bytes/Sector	16	16
512 Bytes/Sector	--	9
1024 Bytes/Sector	--	5
Tracks per Surface	70	80 (77 available for use)

#### Maximum Sustained Transfer Rate (512 Bytes/Sector)

17.6k/s

17.6k/s

#### Average Access Time

497 ms

497 ms

\* Actual figures depend on your computer.

### Functional Characteristics

Rotational Speed	600 rpm
Recording Format	MFM/Double Density
Tracks per Inch	135

---

## Environmental Ranges

---

### Temperature

Operating	10 to 40 degrees C (50 to 104 degrees F)
Non-Operating	-40 to 60 degrees C (-40 to 140 degrees F)

### Humidity

Operating (non-condensing)	20% to 80% with maximum wet-bulb temperature not to exceed 29 degrees C (85 degrees F)
Non-Operating (non-condensing)	5% to 95%

---

**NOTE** The temperature and humidity of the area where you use your disc drive are important. The following graph illustrates acceptable temperature and humidity conditions.

---

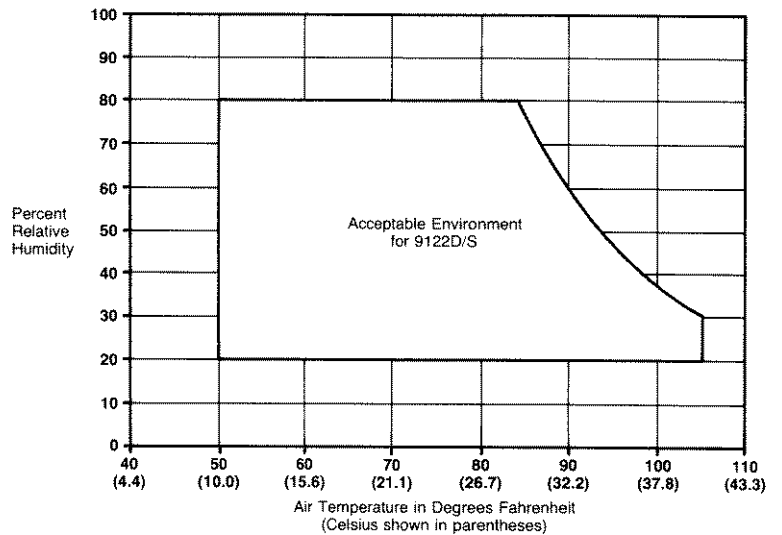

---

**Altitude**

Operating	0 to 4572m (0 to 15000 ft)
Non-Operating	-304 to 15240m (-1000 to 50000 ft)

---

**NOTE**

Operate your disc drive in a clean environment to prolong the lives of your flexible discs and disc drive. HP is not responsible for damages caused by use in a dirty environment.

---

---

**Physical Characteristics**

---

**Dimensions**

Height	75 mm ( 2.9 in.)
Width	325 mm (12.8 in.)
Depth	285 mm (11.2 in.)

**Weight**

	1 drive	2 drives
Net	5.0 kg (11 lbs)	5.4 kg (12 lbs)
Shipping	5.9 kg (13 lbs)	6.4 kg (14 lbs)

---

**Power Requirements**

---

Nominal Voltage	
(selected by rear panel switch)	100-120V (115V setting) 200-240V (220V setting)
Voltage Range	86-127V (115V setting) 195-253V (220V setting)
Nominal Frequency	50-60 Hz
Frequency Range	48-66 Hz
Power	67 W

## Glossary

---

ADDRESS	A number that identifies the exact location to which your computer can send data or from which your computer receives data. Just as you have a unique home address, your disc drive, plotter, and printer must each have a unique address.
BACKUP	A duplicate copy of a disc made in case the original disc is lost or damaged.
BOOTING	Puts your computer in a ready-to-run condition. The computer "pulls itself up by its bootstraps" and gets ready to go. (Booting loads the operating system and utilities into your computer's memory.)
BUS	A bundle of wires over which computer devices can communicate. The bus is similar to a telephone line shared by several telephones with different numbers.
BYTE	A unit of measurement for memory storage. A byte is often used to represent one character, such as a single letter, number, or other symbol.
CABLE	Provides the connection between computers and peripherals (printers, plotters and disc drives). The cable used with this drive is the HP-IB (Hewlett-Packard Interface Bus).
CRT	An acronym for cathode ray tube. The CRT is the video screen of the computer.
DIRECTORY	The table of contents for the files stored on a disc.
DISC	A circular plate of magnetically-coated material used to store computer information. The disc is similar to a phonograph record that stores programs and data instead of music. Hewlett-Packard's 3 1/2-inch flexible disc is enclosed in a plastic case. A disc may be single-sided or double-sided.

DISC ACCESS LIGHT	A light that comes on whenever the computer is getting information from the disc drive or sending information to the disc drive.
DISC DRIVE	A device that allows a computer to read data that is stored on a disc or write data on a disc.
FAULT LIGHT	The red light visible through the air intake slots on the front panel. The light is on during selftest and stays on if there is a problem.
FLEXIBLE DISC	A disc which can be removed from your disc drive. The disc is called flexible because it is made from a flexible piece of polyester.
FORMATTING	The process by which a disc is prepared to receive and store data. Also known as "initializing."  If you think of your disc as a filing cabinet, formatting is equivalent to getting an empty file cabinet and preparing the cabinet for use. First, you check the cabinet for any damage. Similarly, the disc drive checks the disc for any damaged areas in which data cannot be stored. Second, you place hanging folders and dividers in your file cabinet. Likewise, the disc drive sets up storage areas on the disc. Finally, you label your filing cabinet so that you know what is in each drawer. Similarly, the disc drive sets up a directory on your disc.
HARDWARE	The physical parts of the computer system; the computer and the peripheral devices.
HEAD	The part of the disc drive that touches the surface of the disc. It reads data from your disc and writes data onto your disc.
HP-IB	Stands for <b>Hewlett-Packard Interface Bus</b> . The bus is a bundle of wires that allows the computer and the peripherals to communicate.
INITIALIZING	The process by which a disc is prepared to receive and store data. Also known as "formatting."
INTERLEAVE	Interleaving alternately numbers sectors on the disc. The interleave factor affects performance.

KBYTES	A unit of measurement for memory storage, also called "k" or "kilobyte." One kbyte is technically equal to 1,024 bytes.
LOAD	To read programs from a disc or tape into a computer's memory.
MBYTES	A unit of measurement for memory storage. One Mbyte is technically equal to one million bytes.
MFM	Modified frequency modulation (MFM); an encoding method used to store data on discs.
PERIPHERALS	Devices that are external to and controlled by the computer. Peripherals are so called because they are not part of the computer (e.g., tape drives, disc drives, printers and plotters).
PIGGYBACKING	Hooking one HP-IB cable into the back of another HP-IB cable. Piggybacking is one way to connect more peripheral devices to your computer system.
PROGRAM	A set of instructions or steps telling the computer how to handle a problem or task.
READ/WRITE HEAD	see <i>HEAD</i> .
SELFTTEST LIGHT	The red light visible through the air intake slots on the front panel. The light is on during selftest and stays on if there is a problem.
SOFTWARE	A computer program or set of programs.
UTILITY	A program that performs a task required by most users. For example, most users need to make copies of discs. The copy utility is a program that tells the computer how to copy discs.
WRITE PROTECT	A method of protecting disc information from being erased or overwritten.

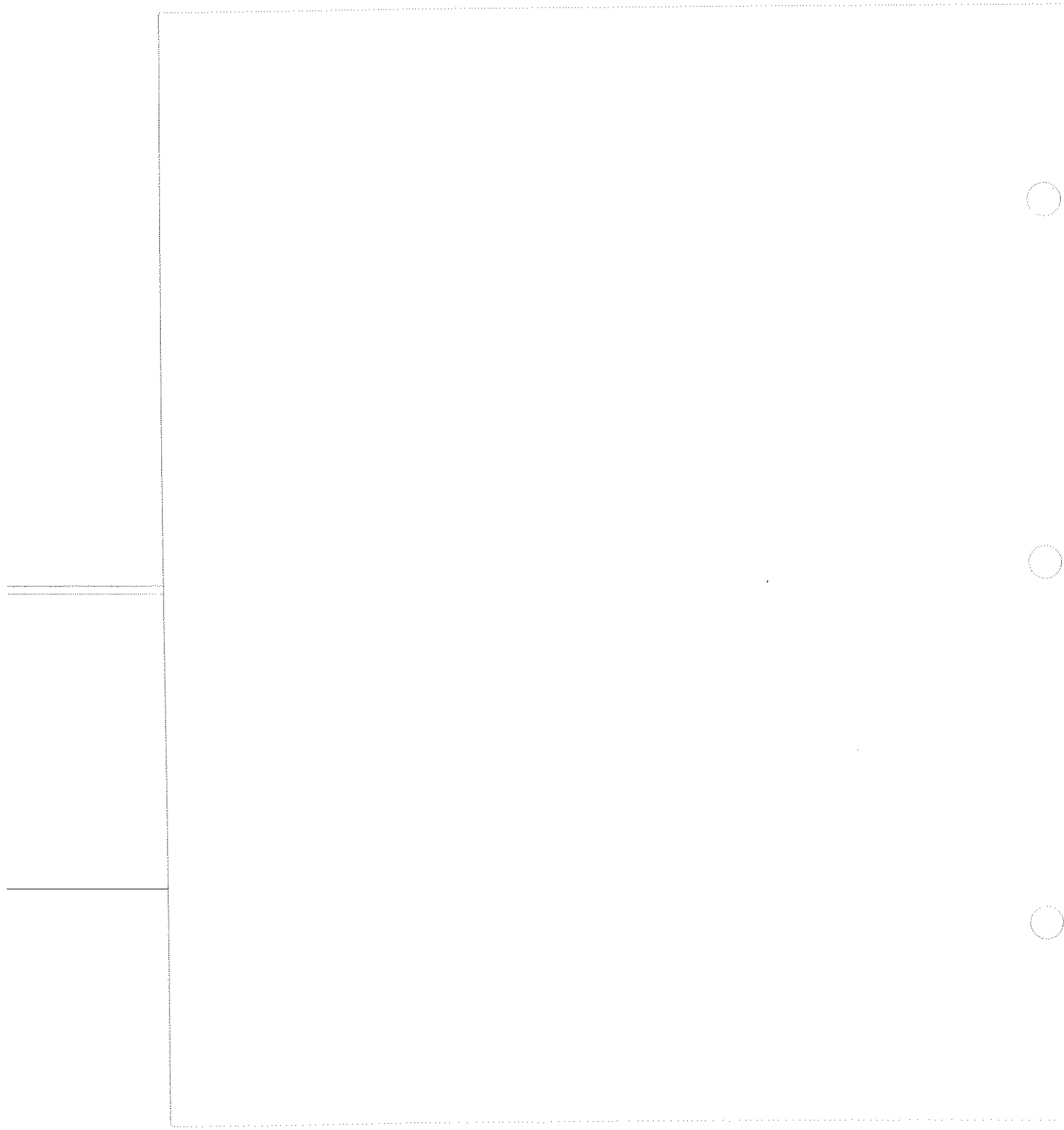



## Index

- A**
- 4-3,A-3 acceptable environment
  - 2-9,3-4 access light
  - A-2 access time
  - 2-3,2-7 AC LINE socket
  - 2-8 addressing
  - 3-1 auto shutter
- B**
- 2-3,2-9 button, eject
  - 2-3,2-9 button, power
- C**
- 2-6 cable, HP-IB
  - 4-6 cable, ordering
  - 2-7 cable, power
  - A-1 cable, restrictions
  - A-2 capacity
  - A-2 characteristics
  - 4-1 cleaning
  - commands (see computer manual)
- D**
- 3-5 data exchange
  - A-1 devices, maximum number
  - 3-1 disc, flexible
  - 2-2 disc, shipping

- 
- 3-4 double-sided discs
  - 3-5 double-sided format
- E**
- 2-3,2-9 eject button
  - 4-3,A-3 environment
  - 4-3 errors
  - 3-5 exchange
  - 2-3 exhaust
- F**
- 2-3,3-9 fault light
  - 3-6 flexible disc, handling
  - 3-7 flexible disc, labeling
  - 3-3 flexible disc, loading
  - 3-8 flexible disc, ordering
  - A-2 flexible disc, specifications
  - A-2 flexible disc, transfer rate
  - 3-3 flexible disc, unloading
  - formatting (see computer manual)
  - A-4 frequency
  - 2-3 front panel
  - 4-2 fuses, changing
  - 4-6 fuses, ordering
  - 2-4,4-2,4-6 fuses, ratings
  - 2-4,4-2,4-6 fuses, selecting
- H**
- 3-6 handling flexible discs
  - 2-6 HP-IB, connecting
  - 2-6 HP-IB, piggybacking

	<b>A-1</b>	HP-IB, restrictions
	<b>3-4</b>	head
	<b>4-3,A-3</b>	humidity
<b>I</b>	<b>2-9</b>	indicator light
		initializing (see computer manual)
	<b>2-6</b>	interface (HP-IB)
		interleaving (see computer manual)
<b>L</b>	<b>3-7</b>	labeling flexible discs
	<b>3-3</b>	loading flexible discs
	<b>2-3,2-9</b>	lights
<b>M</b>	<b>4-2</b>	maintenance
	<b>3-4</b>	Media Monitor
	<b>4-3</b>	messages
	<b>2-2</b>	moving the drive
<b>O</b>	<b>4-6</b>	ordering supplies
<b>P</b>	<b>A-4</b>	physical characteristics
	<b>2-6</b>	piggybacking
	<b>2-3,2-9</b>	power button
	<b>A-4</b>	power cord
	<b>2-9</b>	power-on selftest
	<b>A-4</b>	power requirements
	<b>2-3,2-9</b>	power switch

	<b>4-3</b>	problems
	<b>1-2</b>	product description
<b>R</b>	<b>3-4</b>	read/write head
	<b>2-3</b>	rear panel
	<b>2-9</b>	red light
<b>S</b>	<b>2-9</b>	selftest
	<b>2-3,2-9</b>	selftest light
	<b>2-2</b>	shipping disc
	<b>2-2</b>	shipping the drive
	<b>3-1</b>	shutter
	<b>3-4</b>	single-sided discs
	<b>3-5</b>	single-sided format
	<b>A-2</b>	specifications
	<b>A-2</b>	storage capacity
	<b>2-2</b>	supplies, in package
	<b>4-6</b>	supplies, ordering
	<b>2-8</b>	switch, address
	<b>2-3,2-9</b>	switch, power
	<b>2-4</b>	switch, voltage
<b>T</b>	<b>A-2</b>	transfer rate
	<b>4-3</b>	troubleshooting
<b>U</b>	<b>3-3</b>	unloading flexible discs
	<b>2-2</b>	unpacking

**V**

**2-4,A-4** voltage

**W**

**4-1** warranty

**3-1** window

**2-2** wedges

**3-2** write protecting

## Worldwide Sales Offices

Hewlett-Packard products are sold and supported worldwide through Hewlett-Packard Sales and Service Offices and through dealers.

- *To contact Hewlett-Packard:* There are more than 240 Hewlett-Packard Sales and Service Offices worldwide. To locate the one nearest you, use your telephone directory or contact one of the major Hewlett-Packard offices listed.
- *To contact a dealer:* Call 800/FOR-HPPC in the U.S. or call your local Hewlett-Packard Sales and Service Office. Ask for "Personal Computer Dealer Sales."

### Argentina

- \* Martinez  
Phone: 798-6086

### Australia

- \* North Ryde, N.S.W.  
Phone: 02/887-1611
- \* Blackburn, Victoria  
Phone: 03/890-6351

### Austria

- \* Vienna  
Phone: 222/3516210

### Belgium

**Supplies: 02/762-3200**

- \* Brussels  
Phone: 02/762-3200

### Brazil

- \* Alphaville, Barueri  
Phone: 011/421-1311

### Canada

**Software Assistance:  
1-800/267-6115  
(In English and French)  
Supplies: 514/697-4232**

- \* Edmonton, Alberta  
Phone: 403/452-3670
- \* Richmond, British Columbia  
Phone: 604/270-2277
- \* Mississauga, Ontario  
Phone: 416/678-9430

### Chile

HP Distributor:  
Olympia (Chile)  
Santiago  
Phone: 2/25-5044

### Denmark

- \* Birkerød  
Phone: 2/81-66-40

### El Salvador

HP Distributor  
IPESA  
San Salvador  
Phone: 503/26-6858

### Finland

- \* Espoo  
Phone: 90/455-0211
- \* Jyväskylä  
Phone: 41/216318
- \* Oulu  
Phone: 81/338785

### France

**Supplies: 6/928-32-64**

- \* Les Ulis  
Phone: 1/9077825

### Guatemala

HP Distributor:  
IPESA  
Guatemala City  
Phone: 2/31667

### Hong Kong

- \* Wanchai  
Phone: 5/832-3211

### Italy

- \* Cernusco Sul Naviglio  
Phone: 2/903691

### Japan

Yokogawa-Hewlett-Packard

### \* Osaka

Phone: 6/304-6021

- \* Sagami-hara  
Phone: 427/59-1311

- \* Tokyo  
Phone: 3/331-6111

### Malaysia

- \* Kuala Lumpur  
Phone: 03/943-022

### Mexico

- \* Xochimilco, Mexico City  
Phone: 905/676-8895

### The Netherlands

**Supplies: 020/47-06-39**

- \* Amstelveen  
Phone: 020/472021

### New Zealand

Pakuranga  
Phone: 9/68-7159

### Norway

- \* Oesteraas  
Phone: 2/17-11-80

### Puerto Rico

Carolina  
Phone: 809/762-725

### Saudi Arabia

- \* HP Distributor:  
Modern Electronics  
Riyadh  
Phone: 01/4919715

### Singapore

- \* Singapore  
Phone: 631788

**South Africa****Supplies: 802-5111  
53-7954  
28-4178**

- \* Sandton, Transvaal  
Phone: 11/802-511

**Spain**

- \* H.P. Española, S.A.  
Carretera Nacional  
Vi, Km. 16,400  
Las Rozas (Madrid)  
Phone: 637 00 11 -  
637 40 13

**Sweden**

- \* Spanga  
Phone: 8/750-2000

**Switzerland****Supplies: 057/31-22-54  
or 31-22-59**

- \* Widen  
Phone: 57/31-21-11

**Taiwan**

- \* Taipei  
Phone: 2/712-0404

**United Kingdom****Supplies: 0734/79-2868  
or 0734/79-2959**

- \* Altrincham  
Phone: 61/928-6422
- \* Winnersh, Wokingham  
Phone: 734/784-774

**United States****For assistance before  
your purchase, to  
locate an HP dealer, or  
to obtain your local  
Phone-in Software  
Assistance number:  
800/FOR-HPPC****Hardware maintenance  
information or Dealer  
Repair Center  
locations: 800/835-  
HPPH****Computer Supplies:****-All states except  
California, Alaska, and  
Hawaii:  
800/538-8787****-In California, Alaska,  
and Hawaii:  
408/738-4133 (collect)**

- \* Santa Clara, California  
Phone: 408/988-7000
- \* Los Angeles, California  
Phone: 213/970-7500
- \* Englewood, Colorado  
Phone: 303/649-5000
- \* Atlanta, Georgia  
Phone: 404/955-1500
- \* Rolling Meadows, Illinois  
Phone: 312/255-9800

- \* Rockville, Maryland  
Phone: 301/948-6370
- \* Andover, Massachusetts  
Phone: 617/861-8960
- \* Novi, Michigan  
Phone: 313/349-9200
- \* Paramus, New Jersey  
Phone: 201/265-5000
- \* King of Prussia,  
Pennsylvania  
Phone: 215/265-7000
- \* Richardson, Texas  
Phone: 214/231-6101

**Venezuela**

- \* Caracas  
Phone: 2/239-4133

**West Germany****Supplies: 07031/142829 or  
07031/223133**

- \* Boeblingen  
Phone: 7031/667750

- 
- \* Full Field Repair Center  
capabilities.

