

HP 972A and 973A Multimeter User's Guide

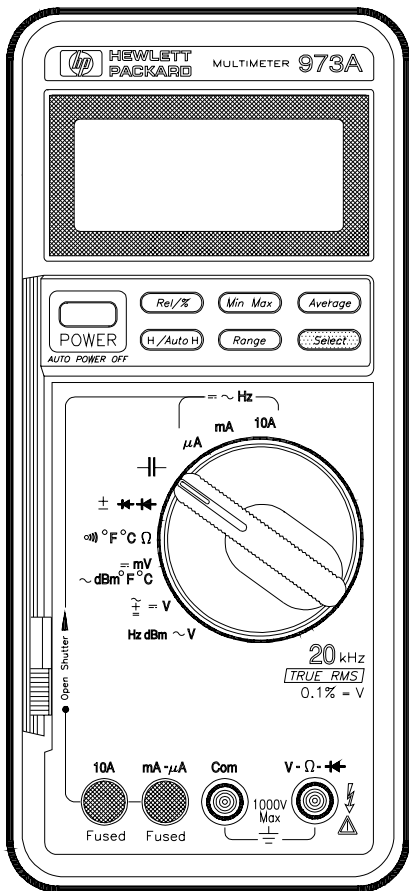

Part Number 00972-90002
March 1995

© Copyright Hewlett-Packard Company 1994, 1995
All Rights Reserved



4

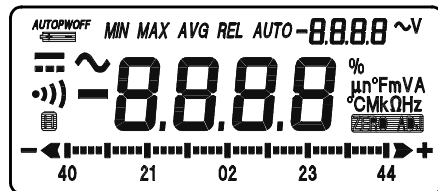

972A

3

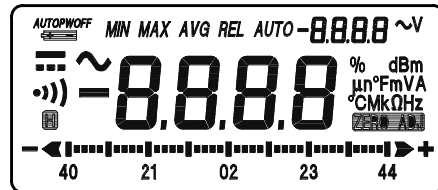

973A

2

1

HP 972A and 973A Multimeters

Table of Contents

Safety Summary	1-4	Specifications	1-17
Safety Symbols	1-4	General	1-17
Maximum Overvoltage Limitations	1-5	DC Voltage	1-17
Probes and Test Leads	1-6	AC Voltage HP 972A	1-18
Operation	1-7	AC Voltage HP 973A	1-18
Terminals, Shutter, & Test Leads	1-7	AC + DC Voltage HP 973A	1-19
Function Switch	1-8	DC Current	1-19
Function Keys	1-9	AC Current	1-20
Function Keys/Function Switch Matrix	1-12	Resistance	1-20
Display	1-13	Continuity	1-20
Audio	1-13	Diode	1-20
Calibration and Adjustment	1-14	Capacitance	1-20
Required Test Equipment	1-14	Frequency (Volts)	1-21
Calibration Procedure	1-14	Frequency (Amps)	1-21
Maintenance	1-15	Temperature	1-22
Battery Replacement	1-15	Temperature HP 973A	1-22
Fuse Replacement	1-15	dBm HP 973A	1-22
Troubleshooting	1-16	Adjustments	6-1
Cleaning	1-16	Calibration Table	6-1
Replaceable Parts/Accessories	1-16	Replaceable Parts/Accessories	6-4
		Disassembly	6-5
		Declaration of Conformity	

Safety Summary

The CAUTIONS and WARNINGS which appear on the following pages must be followed to ensure operator safety and to retain the operating condition of the Multimeter.

1. Do not use this product beyond its specifications or for uses not intended for this product as identified by the product functions, ranges, and hazards as indicted below.
2. To minimize possible electric shock hazard condition, connect only two leads at any one time to any of the multimeter terminals.
3. To prevent possible electric shock hazard condition when using the current function, do not leave one probe connected to the circuit under test and the other probe disconnected, exposed, and readily accessible (touchable).

Safety Symbols



Indicates the operator must refer to an explanation in this manual.



Indicates terminals at which dangerous voltages may exist.

WARNING



TO AVOID ELECTRICAL SHOCK or damage to the multimeter, do not apply more than ± 1000 Vdc or 1000 Vrms between any terminal and earth ground. Use caution when working with voltages above 60 Vdc or 42 Vpeak. Ensure test leads are in good condition.

WARNING



POSSIBLE ELECTRICAL SHOCK. Do not make measurements if the case is damaged or the rear cover is removed. Remove all electrical inputs before removing the rear cover.

WARNING



POSSIBLE ELECTRICAL SHOCK or FIRE HAZARD. Do not expose this multimeter to rain or moisture. Do not operate the multimeter in the presence of flammable gases or fumes.

**WARNING**

POSSIBLE ELECTRICAL SHOCK. Calibration and performance tests are to be performed by qualified personnel only. Do not attempt calibration or test procedures unless qualified to do so.

**CAUTION**

To avoid damage to the multimeter for inputs above 250 Vdc or Vac, disconnect the test leads before changing functions. Do not exceed the maximum input limits shown in the following table.







Maximum Overvoltage Limitations (AC and DC Voltage Functions)

1000V

MAX indicates the maximum voltage between input terminals and earth is ± 1000 V (dc or ac rms).

Do not use the multimeter on any ACV circuit where the maximum impulse overvoltage may be more than 4000Vpk or any DCV circuit where the maximum impulse overvoltage may be more than 2500Vpk between the COM and VOLT terminals. Excessive impulse overvoltage can damage the multimeter voltage functions. Do not measure branch circuits (CAT II) over 600V to earth nor service panel circuits (CAT III) over 300V to earth.

Safety Summary

Function	Maximum Operating Input
  10 A	± 10 A (dc or ac rms) / 600 V
  mA or μ A	± 500 mA (dc or ac rms) / 250 V
Capacitance, Diode Test, Resistance, Continuity, Temperature	660 Vrms (sinewave)
Frequency	660 V rms 2 Hz to 10 kHz 100 V rms 10 kHz to 200 kHz
  V	± 1000 Vdc or Vrms (sinewave)

Probes and Test Leads

1. Always inspect probes before use. Do not use test leads whose insulation has cuts, cracks, or other damage that may result in reduced electric shock protection.
2. Keep insulation surface clean between the probe tip connector and the finger guards.
3. If probes other than the ones specified are to be used with the multimeter, be sure the probes and their leads are rated for the voltage and current to which they will be subjected. Do not exceed the voltage ratings for the multimeter.
4. Probes supplied with this multimeter are rated for use up to 1000Vrms or Vdc.

Operation

Terminals, Shutter, & Test Leads

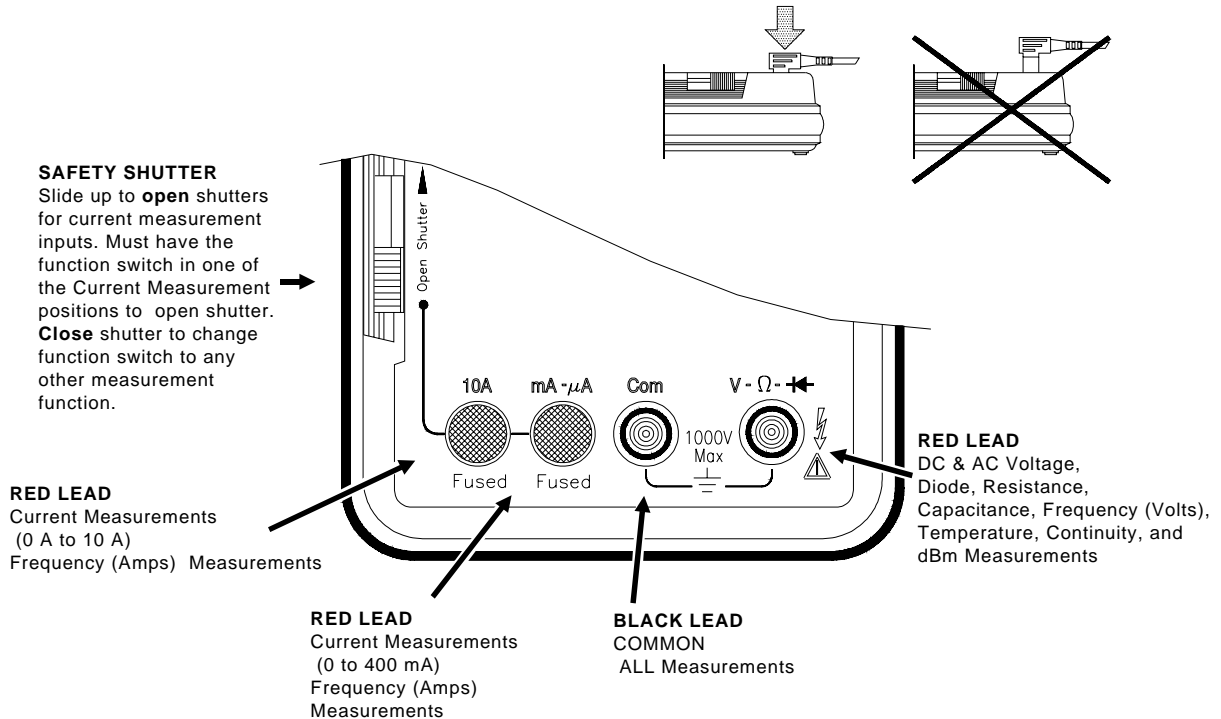

2 Function Switch

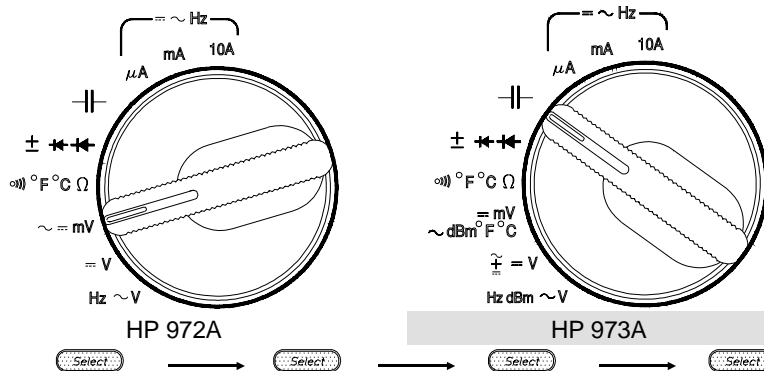

Switch Position	Display	HP 972A	HP 973A	HP 973A	HP 973A
10A	DC Current (10 mA to 10 A)	AC Current (10 mA to 10 A)	Frequency ¹ (2 Hz to 10 kHz)		
mA	DC Current (10 μA to 0.4 A)	AC Current (10 μA to 0.4 A)	Frequency ¹ (2 Hz to 10 kHz)		
μA	DC Current (0.1 μA to 4 mA)	AC Current (0.1 μA to 4 mA)	Frequency ¹ (2 Hz to 10 kHz)		
+	Capacitance (10 pF to 1000 μF)				
*	Diode Test (0 to 2 V)	Auto Diode Test (0 to ±2 V)			
Ω	Resistance (0.1 Ω to 40 MΩ)	Continuity (alarm at < 20 Ω)	Temperature in °F (-112° F to 302° F)	Temperature in °C (-80° C to 150° C)	
mV	DC volts (10 μV to 400 mV)	AC volts (10 μV to 400 mV)	dBm (-59.9 to -5.7 dBm)	Temperature in °F (-58° F to 1292° F)	Temperature in °C (-50° C to 700° C)
= V	DC Volts (1 mV to 1000 V)	DC + AC Volts (to 1000 V)			
~ V	AC volts (to 1000 V)	Frequency ¹ (2 Hz to 200 kHz)	dBm (-19.9 to 62.2 dBm)		

¹ AC input value is shown in secondary display

Function Keys



Power

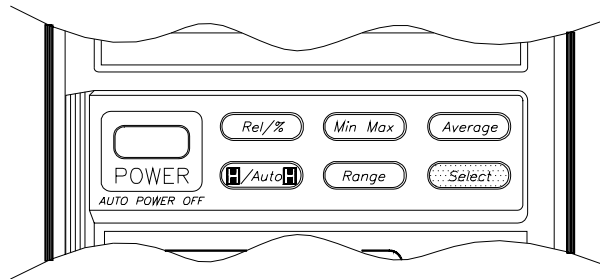

Automatic power off after 30 minutes. Alarm sounds 30 seconds before power off. **Power off** if input < 80 V or < 400 mA. **Power save** if input > 80 V or > 400 mA, last measurement displayed, power consumption is reduced. Press any key or change any function to cancel. Defeat by holding the  key for 2 seconds while applying power.











Relative/Percent

Press	Action	Main Display	Secondary Display
	Makes the last displayed measurement the reference	Each measured value relative to the reference value (difference)	Reference value
	Calculates the percentage change from the reference	Each measured value as a percent change of the reference value	Reference value
	Cancels the Relative/% function	Measured Value	Range

Perform a **zero adjust** when using the 400 Ω range or 40 mV range and displayed value is less than 99 by shorting the test leads and pressing this key. Perform a **zero adjust** on the 10 nF Capacitance range with the leads open. Cycle power to erase the stored zero adjustment.

Operation

Minimum/Maximum ¹



Press	Action	Main Display	Secondary Display ²
	Begin recording of minimum and maximum values	Each measured value	Elapsed time
	Display recorded maximum	Maximum measurement	Time of Maximum
	Display recorded minimum	Minimum measurement	Time of Minimum
	Display last recorded measurement	Latest measurement	Elapsed time
	Pause recording of minimum and maximum values ³	Holds display	Total elapsed time
	Resume recording of minimum and maximum values	Each measured value	Elapsed time
 	Press and hold 1 second to cancel	—	—

¹ Automatic power off and auto ranging are disabled when Min/Max is selected. Bargraph will indicate and hold the maximum values of the bargraph.



² Time is recorded and displayed in minutes up to the maximum recording time of 1999 minutes. Recording will stop at the maximum time.

³ H annunciator is displayed when Min/Max recording

Average





Press	Action	Main Display	Secondary Display
	Makes the displayed measurement the average of the last eight measurements	Average value of last eight measurements	Range
	Disables the averaging of measurements	Each measurement	Range

Hold/Auto-Hold

Press	Action	Main Display	Secondary Display
	Holds the measurement value in the display	Measurement value when hold pressed	Input value
	Enters Auto-Hold function ¹	Measurement value when multimeter beeps	Range
	Cancels Hold function	Measurement value	Range

¹ Auto-Hold Operation. When measurement becomes stable, multimeter will beep and save the stable reading. Removing probe from measuring circuit will display and hold the last stable reading.

Range

Press	Action	Main Display	Secondary Display
	Changes from auto-ranging to manual ranging	Measurement value	Range
	Change manual range UP once with each keypress ¹	Measurement value	Range
 	Returns to auto-ranging when key is held for 1 second	Measurement value	Range

¹ When upper range is reached, the sequence begins again at the lowest range.

Select



Press this key to use the functions indicated in yellow on the multimeter. See table on page 1-8.

To test display, hold this key when turning meter on.

HP 973A: Not all annunciators turned on during the display test.

4 Function Keys and Function Switch Matrix

Function	Relative	% (Percent)	Min/Max ⁵	Average	Data Hold	Auto-Hold	Range
$\mu\text{A}, \text{mA}$	● ²	●	●	●	● ⁶	●	●
10A	● ²	●	●	●	● ⁶	●	
Hz(Amps) ⁶					● ³		● ⁴
⁷	● ¹	●			●		
	● ²	●			● ⁶	●	
					● ⁶		
Ω	● ^{1,2}	●	●	●	● ⁶	●	●
					●		
$^{\circ}\text{F}, ^{\circ}\text{C Therm}^7$	●		●		●		
mV	● ^{1,2}	●	●	●	● ⁶		●
mV	● ²	●	●	●	● ⁶		●
dBm ^{7 3}	● ²				●		
$^{\circ}\text{F}, ^{\circ}\text{C Tc}^7$	●		●		●		
V	● ²	●	●	●	● ⁶	●	●
⁷					●		●
V	● ²	●	●	●	● ⁶	●	●
Hz(Volts) ⁶					● ³		● ⁴
dBm ^{7 3}	● ²				●		

¹ Zero adjust when display shows < 99 on lowest range.

² Secondary display shows reference value.

³ Secondary display shows AC input voltage.

⁴ Changes input attenuator, frequency is always auto range.

⁵ Secondary display shows elapsed time (in minutes).

⁶ Secondary display and bargraph updates with input value.

⁷ Bargraph not available.

Display

Low Battery indicator

Replace batteries when on.

Main Display

(Annunciators shown inside front cover)

Number of digits is set by range and function
Displays O.L. to indicate an overload condition

Entire display flashes if:

- Input overvoltage or
- During Amps fuse check

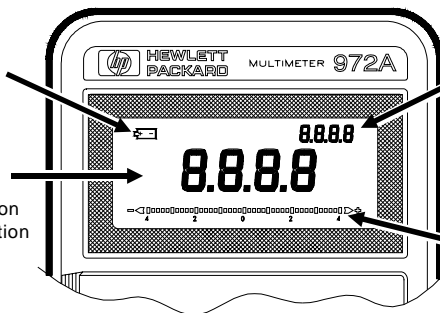

Secondary Display

Shows:

- Range (most functions)
- AC input value (Frequency)
- Reference value (Relative/%)
- Elapsed time (Min/Max)

Bargraph

- Active for all functions except:
- Capacitance, Temperature,
 - AC +DC, dBm

Audio

	<p>Power on First beep at power on. Second beep when beginning to make measurements.</p>
	<p>Single beep Indicates any valid function key press. Indicates a new High or Low value recorded when in Min/Max function.</p>
	<p>Steady repeating beep Indicates when measurement is steady when using Auto-Hold function.</p>
	<p>Rapid repeating beeps Indicates wrong input terminals used for function selected. Indicates an overload condition at the measurement terminals.</p>
	<p>Continuous tone Indicates a resistance of $< 20 \Omega$ when using the Continuity function.</p>
	<p>Auto Power Off/Auto Power Save Pairs of beeps for 30 seconds. Long beep just before power off. Cancel by changing function switch position or pressing any key.</p>

Calibration and Adjustment

Required Test Equipment

The source used for the calibration should have an output accuracy as good or better than that listed in the specifications.

Calibration Procedure

Environmental range for calibration: $23^{\circ}\text{C} \pm 5^{\circ}\text{C}$, < 80% RH

Calibration interval: 1 Year

- 1 Disconnect all inputs from the multimeter and open the case as described on page 6-5.
- 2 Install new batteries (described below) and close the cover. Turn the multimeter on and allow a 30 minute warm-up. Open the case.
- 3 Set the multimeter function and range and the source output to the values specified at each step in the table on page 6-1.
- 4 When appropriate, make the adjustments indicated in the table to bring the multimeter display within the limits.

CAUTION



Dangerous voltages are present during the calibration procedure. Calibration should only be performed by qualified service technicians. Use a non-conductive adjustment tool.

Maintenance

Operator protection from electric shock hazard is provided by a double insulated enclosure. Refer to pages 1-4 and 1-5 for maximum voltage specifications. When servicing, use only specified replacement parts.

Battery Replacement

Replace the battery when the symbol appears in the display or before calibration. Replace both batteries at the same time. Use high-quality type AA alkaline (IEC LR6) batteries. Remove the batteries if the multimeter is to be stored for extended periods of time. Refer to the disassembly drawing on page 6-5.

Fuse Replacement

Fuse locations are shown in the diagram on page 6-5. Fuses are listed in the replaceable part list on page 6-4. See fuse check procedure in the Troubleshooting table below.

CAUTION



For continued protection use only the specified manufacturer part number or HP part number fuse for replacement purposes.

Troubleshooting

Problem	Possible Cause	Suggested Action
Unit won't turn on	Dead Batteries	Replace batteries
Unit won't turn off	Input limit exceeded	Remove test leads and press any key to reset
Display flashes and Rapid beeps	Input limit exceeded	Remove test leads and press any key to reset
	Test leads in wrong terminal for measurement function	Change test leads or function switch position
Battery Annunciator on	Low battery voltage	Replace batteries
Unable to measure current 10 A or mA - μ A	Open input protection fuse	Check fuse. Connect test lead between V input terminal and 10A or mA μ A terminal. Unit will rapidly beep if fuse is OK. Replace fuse if no beep.

Cleaning

Wipe instrument with a soft rag dampened with soap and water. Do not immerse in water. Do not use chemical cleanser or solvents.

Replaceable Parts/Accessories

Refer to the disassembly diagram on page 6-5.

Specifications

Calibration period: one year minimum. Specifications apply at 23° C ± 5° C, < 80% RH
 Accuracy = ±(% of reading + number of digits)
 Temperature Coefficient = Accuracy X 0.1° C (-10° C to 18° C; 28° C to 55° C)

General

Do not expose product to moisture or rain. Do not use product in flammable atmosphere.

Operating Temperature: -10° to 50°C.

Humidity: 0°C to 40°C / 80% RH max, 40°C to 50°C / 70% RH max (no condensation).

Storage Temperature: -25° to 60°C / 70% RH max (no condensation).

Display reading rate:

ACV, DCV, Diode, Continuity:	Approximately 2.3/second
Frequency	Approximately 1/second
Capacitance	Approximately 0.03 to 2/second
AC + DC	Approximately 0.5 to 1/second

Bargraph reading rate:

Approximately 23/second

Battery life: Approximately 600 hours

DC Voltage

Range	Resolution	972A	973A	Input Resistance
		Accuracy		
40 mV	10 μV	± (0.2% + 1)	± (0.3% + 5)	10 MΩ (nominal)
400 mV	100 μV		± (0.1% + 1)	11 MΩ (nominal)
4 V	1 mV			
40 V	10 mV			
400 V	100 mV		± (0.2% + 1)	10 MΩ (nominal)
1000 V	1 V			

Normal Mode Rejection Ratio: > 60 dB @ 50 or 60 Hz

Effective Common Mode Rejection Ratio (1 kΩ imbalance): > 120 dB @ 50 or 60 Hz

Specifications

AC Voltage HP 972A (Average responding, calibrated to display rms)

Range	Resolution	Accuracy				Input Impedance (nominal)
		40 Hz to 50 Hz	50 Hz to 1 kHz	1 kHz to 5 kHz	5 kHz to 20 kHz	
40 mV	10 μ V	$\pm (1\% + 10)$		Not Specified		10 M Ω < 70 pF
400 mV	0.1 mV	$\pm (1\% + 3)$		Not Specified		
4 V	1 mV	$\pm (1\% + 3)$		$\pm (1.5\% + 3)$	$\pm (3\% + 6)$	11 M Ω < 50 pF
40 V	10 mV	$\pm (1\% + 2)$	$\pm (0.5\% + 2)$			10 M Ω < 50 pF
400 V	100 mV					
1000 V	1 V	$\pm (1\% + 2)$ (40 Hz to 500 Hz)		Not Specified		

Common Mode Rejection Ratio (1 k Ω imbalance): > 60 dB @ DC to 60 Hz
 Response time: 2 seconds maximum

AC Voltage HP 973A (True rms, calibrated for sinewave)

Range	Resolution	Accuracy				Input Impedance (nominal)
		40 Hz to 50 Hz	50 Hz to 1 kHz	1 kHz to 5 kHz	5 kHz to 20 kHz	
40 mV	10 μ V	$\pm (1\% + 3)$	$\pm (1\% + 3)$	Not Specified		10 M Ω < 70 pF
400 mV	0.1 mV			Not Specified		11 M Ω < 50 pF
4 V	1 mV		$\pm (0.7\% + 3)$	$\pm (1.2\% + 4)$	$\pm (2\% + 15)$	
40 V	10 mV					10 M Ω < 50 pF
400 V	100 mV					
1000 V	1 V	$\pm (1\% + 4)$ (40 Hz to 500 Hz)		Not Specified		

Measurement range:

40 Hz to 1 kHz	40 mV to 400 V range	5% to 100% of range
	1000 V range	100 V to 1000 V
1 kHz to 20 kHz	4 V to 400 V range	10% to 100% of range

Response time: <2 seconds on fixed range

Crest factor: <3

Common Mode Rejection Ratio (1 k Ω imbalance): > 60 dB @ DC to 60 Hz

AC + DC Voltage HP 973A (True rms, computed from acV, dcV)

Range	Resolution	Accuracy			Input Impedance (nominal)
		DC, 40 Hz to 1 kHz	DC, 1 kHz to 5 kHz	DC, 5 kHz to 20 kHz	
4 V	1 mV	± (1% + 4)	± (1.5% + 6)	± (3% + 18)	11 MΩ < 50 pF
40 V	10 mV				
400 V	100 mV				
1000 V	1 V	± (1% + 6) DC, to 500 Hz	Not Specified		10 MΩ < 50 pF

Measurement range:

DC, 40 Hz to 1 kHz	4 V to 400 V range 1000 V range	5% to 100% of range 200 V to 1000 V
DC, 1 kHz to 20 kHz	4 V to 400 V range	10% to 100% of range

Response time: < 5 seconds on fixed range

Crest factor: <3

Common Mode Rejection Ratio (1 kΩ imbalance): > 60 dB @ DC to 60 Hz

DC Current

Range	Resolution	Accuracy	Input Resistance	Maximum Input
400 μA	100 nA	± (0.5% + 2)	< 550 Ω	± 0.5 A (fused)
4000 μA	1 μA	± (0.8% + 2)		
40 mA	10 μA			
400 mA	100 μA	± (1.0% + 2)	< 8 Ω	
10 A	10 mA		< 0.05 Ω	± 15 A (fused)

Specifications

AC Current

Range	Resolution	Accuracy (40 Hz to 2 kHz)	Input Resistance	Maximum Input
400 μ A	100 nA	$\pm (1.5\% + 4)$	< 550 Ω	0.5 Arms (fused)
4000 μ A	1 μ A			
40 mA	10 μ A		< 8 Ω	
400 mA	100 μ A			
10 A	10 mA		< 0.05 Ω	15 Arms (fused)

HP 972A average responding

HP 973A rms responding, crest factor <3, specified for 5% to 100% of range

Resistance

Range	Resolution	Accuracy	Test Current	Max Open Circuit Voltage
400 Ω	100 m Ω	$\pm (0.2\% + 1)$ ¹	< 0.8 mA	< 3.2 V
4.0 k Ω	1 Ω	$\pm (0.2\% + 1)$	< 80 μ A	< 1.1 V
40 k Ω	10 Ω		< 10 μ A	
400 k Ω	100 Ω		< 1.1 μ A	
4.0 M Ω	1 k Ω	$\pm (0.5\% + 1)$	110 nA	
40 M Ω	10 k Ω	$\pm (1.2\% + 1)$		

¹ After zero adjust of input leads. Zero adjust range up to 9.9 Ω .

Continuity

Measurement Current: 0.8 mA maximum

Displayed resistance: 0 Ω to 400 Ω

Alarm: Tone when input < 20 Ω

Open circuit voltage: < 3.2 V_{peak}

Input protection: 660 V_{rms} (sinewave)

Resolution: 100 m Ω

Diode

Measurement current: +0.5 mA nominal @ 0.6 V

Displayed Voltage: 0 V to 2.000 V

Accuracy: $\pm (1\% + 2)$

Open circuit voltage: < 3.2 V_{peak}

Input protection: 660 V_{rms} (sinewave)

Resolution: 1 mV

Capacitance

Range	Resolution	Accuracy
10 nF	10 pF ¹	± (2% + 3)
100 nF	100 pF	
1000 nF	1 nF	± (1.2% + 2)
10 μF	10 nF	
100 μF	100 nF	± (3% + 2)
1000 μF	1 μF	

¹ After zero adjust of input leads

Method used: Charge/Discharge of capacitor under test

Maximum display 1199

Frequency (Volts)

Frequency Range	Resolution	Accuracy	Input Voltage (rms)	Maximum Input
2 Hz to 99.99 Hz	0.01 Hz	± (0.02% + 1)	0.2 V to 400 V	660 Vrms
90 Hz to 999.0 Hz	0.1 Hz			
900 Hz to 9999 Hz	1 Hz		0.4 V to 400 V	
9.00 kHz to 99.99 kHz	10 Hz		0.8 V to 100 V	100 Vrms
90 kHz to 200 kHz	100 Hz		2 V to 100 V	

Frequency (Amps)

Frequency Range	Resolution	Accuracy	Input Current (rms)	Maximum Input
2 Hz to 99.99 Hz	0.01 Hz	± (0.02% + 1)	50 μA to 10 A	15 A (fused)
90 Hz to 999.0 Hz	0.1 Hz			
900 Hz to 9999 Hz	1 Hz			

Response time 3 sec max on fixed range

Specifications

Temperature (5 k Ω @ 25° C Thermistor probe)

	° C	° F
Measurement Range	-80° to 150°	-112° to 302°
Resolution	0.1°	0.2°
Accuracy ¹	$\pm 0.3^\circ$ C	$\pm 0.5^\circ$ F

¹ Accuracy does not include 5 k Ω Thermistor error

Temperature HP 973A (K type Thermocouple probe)

	° C	° F
Measurement Range	-50° to 700°	-58° to 1292°
Resolution	1°	1°
Accuracy ¹	$\pm (2\% + 2^\circ)$	$\pm (2\% + 4^\circ)$

¹ Accuracy does not include K type Thermocouple error

dBm HP 973A (600 Ω , 1 mW reference)

Function	Input dBm	Input Voltage	Accuracy		
			40 Hz to 1 kHz	1 kHz to 5 kHz	5 kHz to 20 kHz
ACmV	-51.8 dBm to -5.7 dBm	2.0 mV to 400 mV	± 0.3 dBm	Not specified	
AC V	-11.8 dBm to -5.7 dBm	0.2 V to 0.4 V	± 0.2 dBm	± 0.2 dBm	± 0.7 dBm
	-5.7 dBm to 53.3 dBm	0.4 V to 360 V			
	53.3 dBm to 62.2 dBm	360 V to 1000 V	± 0.2 dBm 40 Hz to 500 Hz	Not specified	

Adjustments

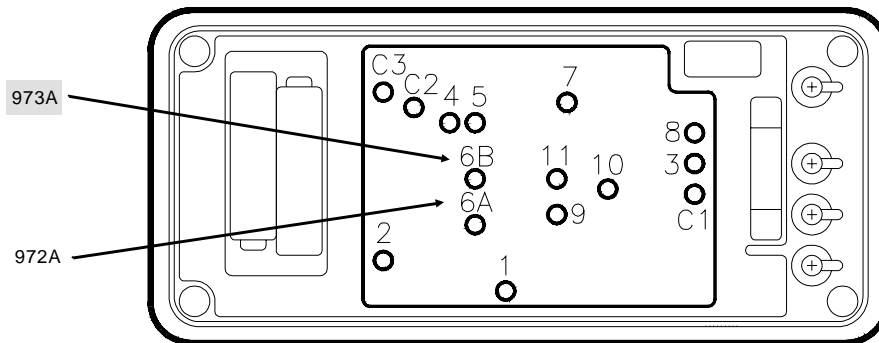

Calibration Table



CAUTION

Dangerous voltages are present during the calibration procedure. Calibration should only be performed by qualified service technicians. Use a non-conductive tool.

Step	Function	Range	Input Signal	Adjustment (limits)	Tolerance (counts)	
					972A	973A
1	mV	400 mV	Short	—	±1	±1
2			380.0 mV	1 (±1)	±8	±4
3		40 mV	38.00 mV	2 (±1)	±18	±16
4	V	400 V	380.0 V	3 (±1)	±8	±4
5		4 V	3.800 V	4 (±1)	±8	±4
6		40 V	38.00 V	5 (±1)	±8	±4

Calibration Table

Step	Function	Range	Input Signal	Adjustment (limits)	Tolerance (counts)	
					972A	973A
7	$\overline{=}$ V	1000 V	1000 V	—	±3	±3
8	\sim V	400 V	380.0 V @ 100 Hz	6A or 6B (±2)	±21	±29
9			380.0 V @ 5 kHz	C1 (±3)	±60	±49
10			380.0 V @ 20 kHz	—	±120	±91
11		4 V	3.800 V @ 5 kHz	C2 (±3)	±60	±49
12			3.800 V @ 100 Hz	—	±21	±29
13			3.800 V @ 20 kHz	—	±120	±91
14		40 V	38.00 V @ 5 kHz	C3 (±3)	±60	±49
15			38.00 V @ 100 Hz	—	±21	±29
16			38.00 V @ 20 kHz	—	±120	±91
17		\sim mV	40 mV	38.00 mV @ 100 Hz	7 (±2)	±48
18	400 mV		380.00 mV @ 100 Hz	—	±41	±41
19	\sim V	1000 V	1000 V @ 100 Hz	—	±12	±14
20	$\overline{=}$ μ A	400 μ A	380.0 μ A	—	±21	±21
21		4000 μ A	3800 μ A	—	±32	±32
22	$\overline{=}$ mA	40 mA	38.00 mA	—	±32	±32
23		400 mA	380.0 mA	—	±40	±40
24	$\overline{=}$ 10 A	10 A	10.00 A	8 (±2)	±12	±12
25	\sim μ A	400 μ A	380.0 μ A @ 100 Hz	—	±61	±61
26			380.0 μ A @ 2 kHz	—	±61	±61
27		4000 μ A	3800 μ A @ 100 Hz	—	±61	±61
28			3800 μ A @ 2 kHz	—	±61	±61

Step	Function	Range	Input Signal	Adjustment (limits)	Tolerance (counts)	
					972A	973A
29	~ mA	40 mA	38.00 mA @ 100 Hz	—	±61	±61
30			38.00 mA @ 2 kHz	—	±61	±61
31		400 mA	380.0 mA @ 100 Hz	—	±61	±61
32			380.0 mA @ 2 kHz	—	±61	±61
33	~ 10 A	10 A	10.00 A @ 100 Hz	—	±19	±19
34			10.00 A @ 2 kHz	—	±19	±19
35	Ω	400 Ω	Short	zero adjust ¹	±1	±1
36			380.0 Ω	—	±8	±8
37		4 kΩ	3.800 kΩ	—	±8	±8
38		40 kΩ	38.00 kΩ	—	±8	±8
39		400 kΩ	380.0 kΩ	—	±8	±8
40		4 MΩ	3.800 MΩ	—	±20	±20
41		40 MΩ	38.00 MΩ	—	±40	±40
42	o)))	400 Ω	0 Ω to 100 Ω	—	Tone below approx 20 Ω	
43	**	2 V	1.000 V	—	±12	±12
44	H	100 μF	90.0 μF	9 (±2)	±29	±29
45		10 μF	9.00 μF	10 (±2)	±12	±12
46		10 nF	Open	zero adjust ¹	±1	±1
47		100 nF	90.0 nF	11 (±2)	±21	±21
48		10 nF	9.00 nF	—	±21	±21
49		1000 nF	900 nF	—	±12	±12
50		1000 μF	900 μF	—	±29	±29
51	Hz (V)	4 V	9000 Hz @ 1 Vrms	—	±2	±2
52	Hz (A)	400 μA	9000 Hz @ 100 μA	—	±2	±2

¹ Perform zero adjustment using  key.

Replaceable Parts/Accessories

Refer to the disassembly diagram on page 6-5.

Call out	Description	HP Part Number	
F1	Fuse, 500 mA, 250 V fast blow Littlefuse 216-500 DO NOT SUBSTITUTE	2110-0940	
F2	Fuse, 15 A, 600 V fast blow Littlefuse KLK15 DO NOT SUBSTITUTE	2110-0941	
MP1	Top case assembly	00972-64401	00973-64401
MP2	Dust/moisture seal	00971-64403	
MP3	Bottom case assembly (includes stand)	00972-64402	
	Replacement Test Leads, 2 pair	E2305A	
	Temperature probe, 5 K Ω Thermistor	E2308A	
	Surface temperature sensor, Thermistor $\pm 0.1^{\circ}\text{C}$ 12" lead, requires dual banana plug	40653B	
	Temperature probe, K type thermocouple for 973A only	E2307A	
	Rubber Boot	00971-86001	
	Soft Case (fits meter with rubber boot)	E2304A	

Operator protection from electric shock hazard is provided by a double insulated enclosure. Refer to the Safety Summary for maximum voltage specifications. When servicing, use only specified replacement parts.

Disassembly



WARNING

Always disconnect the test leads before opening the case.

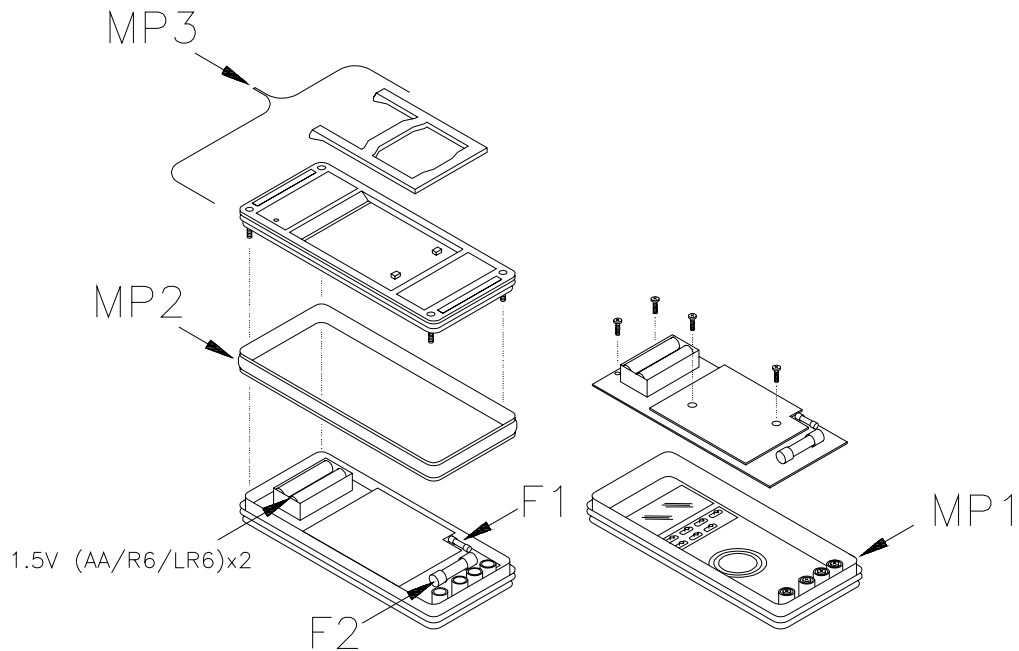

DECLARATION OF CONFORMITY

according to ISO / IEC Guide 22 and EN 45014

Manufacturer's Name: Hewlett-Packard Company, Personal Measurements Operation
Manufacturer's Address: 815 14th Street S.W., Loveland, Colorado 80537 U.S.A.

declares, that the products

Product Name: Handheld Multimeter
Model Number: HP 971A, HP 972A, HP 973A, HP 974A
Product Options: None

conforms to the following Product Specifications:

Safety: IEC 1010-01 (1990) Incl. Amend 1 (1992) / EN61010 (1993)
CSA C22.2 #1010.1 (1992)
UL 1244

EMC: CISPR 11:1990 / EN55011 (1991): Group 1, Class A
IEC801-2:1991 / EN50082-1 (1992): 4 kV CD, 8 kV AD
IEC 801-3:1984 / EN50082-1 (1992): 3 V/m
IEC 801-4:1988 / EN50082-1 (1992): 0.5 kV Signal Lines

Supplemental Information: The product herewith complies with the requirements of the Low Voltage Directive 73 / 23 / EEC and the EMC Directive 89 / 336 / EEC amended by 93 / 68 / EEC (inclusive 93 / 68 / EEC) and carries the CE mark accordingly.

Loveland, Colorado April 1, 1994



Jim White, QA Manager

European Contact: Your local Hewlett-Packard Sales and Service Office or Hewlett-Packard GmbH,
Department ZQ / Standards Europe, Herrenberger Straße 130, D-71034 Böblingen (FAX: +49-7031-143143).

Warranty/Service

Limited 3 Year Warranty

What is Covered

The HP 972A or HP 973A Multimeter is warranted by Hewlett-Packard against defects in materials and workmanship for three years from the date of original purchase. If you sell your unit or give it as a gift, the warranty is automatically transferred to the new owner and remains in effect for the original three year period. During the warranty period, we will repair, or at our option, replace at no charge, a product that proves to be defective, provided you return the product, shipping prepaid, to a Hewlett-Packard service center.

What is Not Covered

This warranty does not apply if the product has been damaged by accident of misuse or as the result of service or modification by other than an authorized Hewlett-Packard service center.

No other express warranty is given. The repair or replacement of a product is your exclusive remedy. ANY OTHER IMPLIED WARRANTY OF MERCHANTABILITY OR FITNESS IS LIMITED TO THE THREE YEAR DURATION OF THIS WRITTEN WARRANTY. Some states, provinces, or countries do not allow the exclusion or limitation or incidental or consequential damages, so the above limitation or exclusion may not apply to you.

The warranty gives you specific legal rights, and you may also have other rights which vary from state to state, province to province, or country to country.

Service

Hewlett-Packard maintains service centers in many countries throughout the world. You may have your unit repaired at a Hewlett-Packard service center any time it needs service, whether the unit is under warranty or not. There is a charge for repairs after the warranty period. Repair or replacement during the first 30 days after purchase will be provided by the sales channel. After 30 days, contact the nearest service office.

Hewlett-Packard products normally are repaired and reshipped within five (5) working days of receipt at any service center. This is an average time and could possibly vary depending upon the time of year and work load at the service center. The total time you are without your unit will depend largely on the shipping time.