



HP 75000 SERIES C

HP E1445A Arbitrary Function Generator

Service Manual

Serial Numbers

This manual applies directly to instruments with serial numbers prefixed with 3144A.



Copyright© Hewlett-Packard Company, 1996



E1445-90011
E0996

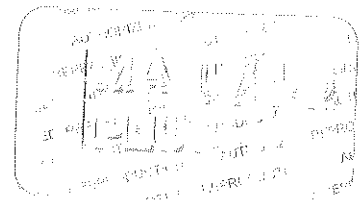

Manual Part Number: E1445-90011

Printed: September 1996 Edition 2
Printed in U.S.A. E0996

HP 75000 SERIES MANUAL
Arbitrary Function Generator



Contents

Chapter 1 - General Information

Introduction	9
Safety Considerations	10
Warnings and Cautions	10
Inspection/Shipping	12
Initial Inspection	12
Shipping Guidelines	13
Environment	14
AFG Description	14
AFG Specifications	14
AFG Options	14
AFG Serial Numbers	14
Recommended Test Equipment	15

Chapter 2 - Verification Tests

Introduction	17
Test Conditions/Procedures	17
Performance Test Record	17
Verification Test Examples	17
Command Coupling	18
Functional Verification	18
Self-Test	19
Ref In/Marker Out Test	20
Start Arm In Test	21
Start Arm In Test (cont'd)	22
Gate In Test	23
Output Relay Test	25
Operation Verification	32
Performance Verification	32
Test 2-1: DC Zeros	33
Test 2-2: DC Accuracy	38
Test 2-3: DC Offset	41
Test 2-4: AC Accuracy	45
Test 2-5: AC Flatness - 250 kHz Filter	49
Test 2-6: AC Flatness - 10 MHz Filter	52
Test 2-7: Frequency Accuracy	56
Test 2-8: Duty Cycle	60
Test 2-9: Total Harmonic Distortion	64
Test 2-10: Spurious/Non-Harmonic Distortion	69
Performance Test Record	73
AFG Test Limits	73
Measurement Uncertainty	73
Test Accuracy Ratio (TAR)	74

Chapter 3 - Adjustments

Introduction	83
Required Equipment	83
Recommended Environment	83
Calibration Commands	83
Defeating Calibration Security	86
DC Adjustment Procedure	87
AC Flatness Adjustment Procedure - 250 kHz Filter	93
AC Flatness Adjustment Procedure - 10 MHz Filter	94
Skew DAC Adjustment Procedure	109

Chapter 4 - Replaceable Parts

Introduction	117
Exchange Assemblies	117
Ordering Information	117
Replaceable Parts List	117

Chapter 5 - Service

Introduction	121
Equipment Required	121
Service Aids	121
Troubleshooting Techniques	122
Identifying the Problem	122
Testing the Assembly	122
Disassembly	123
Removing BNC Connectors	124
Repair/Maintenance Guidelines	125
ESD Precautions	125
Soldering Printed Circuit Boards	125
Post-Repair Safety Checks	125

Certification

Hewlett-Packard Company certifies that this product met its published specifications at the time of shipment from the factory. Hewlett-Packard further certifies that its calibration measurements are traceable to the United States National Institute of Standards and Technology (formerly National Bureau of Standards), to the extent allowed by that organization's calibration facility, and to the calibration facilities of other International Standards Organization members.

Warranty

This Hewlett-Packard product is warranted against defects in materials and workmanship for a period of three years from date of shipment. Duration and conditions of warranty for this product may be superseded when the product is integrated into (becomes a part of) other HP products. During the warranty period, Hewlett-Packard Company will, at its option, either repair or replace products which prove to be defective.

For warranty service or repair, this product must be returned to a service facility designated by Hewlett-Packard (HP). Buyer shall prepay shipping charges to HP and HP shall pay shipping charges to return the product to Buyer. However, Buyer shall pay all shipping charges, duties, and taxes for products returned to HP from another country.

HP warrants that its software and firmware designated by HP for use with a product will execute its programming instructions when properly installed on that product. HP does not warrant that the operation of the product, or software, or firmware will be uninterrupted or error free.

Limitation Of Warranty

The foregoing warranty shall not apply to defects resulting from improper or inadequate maintenance by Buyer, Buyer-supplied products or interfacing, unauthorized modification or misuse, operation outside of the environmental specifications for the product, or improper site preparation or maintenance.

The design and implementation of any circuit on this product is the sole responsibility of the Buyer. HP does not warrant the Buyer's circuitry or malfunctions of HP products that result from the Buyer's circuitry. In addition, HP does not warrant any damage that occurs as a result of the Buyer's circuit or any defects that result from Buyer-supplied products.

NO OTHER WARRANTY IS EXPRESSED OR IMPLIED. HP SPECIFICALLY DISCLAIMS THE IMPLIED WARRANTIES OF MERCHANTABILITY AND FITNESS FOR A PARTICULAR PURPOSE.

Exclusive Remedies

THE REMEDIES PROVIDED HEREIN ARE BUYER'S SOLE AND EXCLUSIVE REMEDIES. HP SHALL NOT BE LIABLE FOR ANY DIRECT, INDIRECT, SPECIAL, INCIDENTAL, OR CONSEQUENTIAL DAMAGES, WHETHER BASED ON CONTRACT, TORT, OR ANY OTHER LEGAL THEORY.

Notice

The information contained in this document is subject to change without notice. HEWLETT-PACKARD (HP) MAKES NO WARRANTY OF ANY KIND WITH REGARD TO THIS MATERIAL, INCLUDING, BUT NOT LIMITED TO, THE IMPLIED WARRANTIES OF MERCHANTABILITY AND FITNESS FOR A PARTICULAR PURPOSE. HP shall not be liable for errors contained herein or for incidental or consequential damages in connection with the furnishing, performance or use of this material. This document contains proprietary information which is protected by copyright. All rights are reserved. No part of this document may be photocopied, reproduced, or translated to another language without the prior written consent of Hewlett-Packard Company. HP assumes no responsibility for the use or reliability of its software on equipment that is not furnished by HP.

U.S. Government Restricted Rights

The Software and Documentation have been developed entirely at private expense. They are delivered and licensed as "commercial computer software" as defined in DFARS 252.227- 7013 (Oct 1988), DFARS 252.211-7015 (May 1991) or DFARS 252.227-7014 (Jun 1995), as a "commercial item" as defined in FAR 2.101(a), or as "Restricted computer software" as defined in FAR 52.227-19 (Jun 1987)(or any equivalent agency regulation or contract clause), whichever is applicable. You have only those rights provided for such Software and Documentation by the applicable FAR or DFARS clause or the HP standard software agreement for the product involved.

HP E1445A Arbitrary Function Generator Service Manual
Edition 2



Copyright © 1996 Hewlett-Packard Company. All Rights Reserved.

Printing History

The Printing History shown below lists all Editions and Updates of this manual and the printing date(s). The first printing of the manual is Edition 1. The Edition number increments by 1 whenever the manual is revised. Updates, which are issued between Editions, contain replacement pages to correct the current Edition of the manual. Updates are numbered sequentially starting with Update 1. When a new Edition is created, it contains all the Update information for the previous Edition. Each new Edition or Update also includes a revised copy of this printing history page. Many product updates or revisions do not require manual changes and, conversely, manual corrections may be done without accompanying product changes. Therefore, do not expect a one-to-one correspondence between product updates and manual updates.

Edition 1 (Part Number E1445-90010). September 1992

Edition 2 (Part Number E1445-90011). September 1996

Safety Symbols



Instruction manual symbol affixed to product. Indicates that the user must refer to the manual for specific WARNING or CAUTION information to avoid personal injury or damage to the product.



Alternating current (AC).



Direct current (DC).



Indicates hazardous voltages.



Indicates the field wiring terminal that must be connected to earth ground before operating the equipment—protects against electrical shock in case of fault.

WARNING

Calls attention to a procedure, practice, or condition that could cause bodily injury or death.

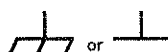

Frame or chassis ground terminal—typically connects to the equipment's metal frame.

CAUTION

Calls attention to a procedure, practice, or condition that could possibly cause damage to equipment or permanent loss of data.

WARNINGS

The following general safety precautions must be observed during all phases of operation, service, and repair of this product. Failure to comply with these precautions or with specific warnings elsewhere in this manual violates safety standards of design, manufacture, and intended use of the product. Hewlett-Packard Company assumes no liability for the customer's failure to comply with these requirements.

Ground the equipment: For Safety Class 1 equipment (equipment having a protective earth terminal), an uninterruptible safety earth ground must be provided from the mains power source to the product input wiring terminals or supplied power cable.

DO NOT operate the product in an explosive atmosphere or in the presence of flammable gases or fumes.

For continued protection against fire, replace the line fuse(s) only with fuse(s) of the same voltage and current rating and type. DO NOT use repaired fuses or short-circuited fuse holders.

Keep away from live circuits: Operating personnel must not remove equipment covers or shields. Procedures involving the removal of covers or shields are for use by service-trained personnel only. Under certain conditions, dangerous voltages may exist even with the equipment switched off. To avoid dangerous electrical shock, DO NOT perform procedures involving cover or shield removal unless you are qualified to do so.

DO NOT operate damaged equipment: Whenever it is possible that the safety protection features built into this product have been impaired, either through physical damage, excessive moisture, or any other reason, REMOVE POWER and do not use the product until safe operation can be verified by service-trained personnel. If necessary, return the product to a Hewlett-Packard Sales and Service Office for service and repair to ensure that safety features are maintained.

DO NOT service or adjust alone: Do not attempt internal service or adjustment unless another person, capable of rendering first aid and resuscitation, is present.

DO NOT substitute parts or modify equipment: Because of the danger of introducing additional hazards, do not install substitute parts or perform any unauthorized modification to the product. Return the product to a Hewlett-Packard Sales and Service Office for service and repair to ensure that safety features are maintained.

Declaration of Conformity
according to ISO/IEC Guide 22 and EN 45014

Manufacturer's Name: Hewlett-Packard Company
Loveland Manufacturing Center

Manufacturer's Address: 815 14th Street S.W.
Loveland, Colorado 80537

declares, that the product:

Product Name: Arbitrary Function Generator

Model Number: HP E1445A

Product Options: All

conforms to the following Product Specifications:

Safety: IEC 1010-1 (1990) Incl. Amend 2 (1995)/EN61010-1/A2 (1995)
CSA C22.2 #1010.1 (1992)
UL 3111

EMC: CISPR 11:1990/EN55011 (1991): Group 1, Class A
IEC 801-2:1991/EN50082-1 (1992): 4kV CD, 8kV AD
IEC 801-3:1984/EN50082-1 (1992): 3 V/m
IEC 801-4:1988/EN50082-1 (1992): 1kV Power Line
0.5kV Signal Lines

Supplementary Information: The product herewith complies with the requirements of the Low Voltage Directive 73/23/EEC and the EMC Directive 89/336/EEC and carries the "CE" marking accordingly.

Tested in a typical HP C-Size VXI mainframe.

July 29, 1996



Jim White, Quality Manager

European contact: Your local Hewlett-Packard Sales and Service Office or Hewlett-Packard GmbH, Department HQ-TRE, Herrenberger Straße 130, D-71034 Böblingen, Germany (FAX +49-7031-14-3143).

Notes

Please fold and tape for mailing

Reader Comment Sheet

HP E1445A Arbitrary Function Generator Service Manual
Edition 2 (part number E1445-90011)

You can help us improve our manuals by sharing your comments and suggestions. In appreciation of your time, we will enter you in a quarterly drawing for a Hewlett-Packard Palmtop Personal Computer (U.S. government employees are not eligible for the drawing).

_____ Your Name	_____ City, State/Province
_____ Company Name	_____ Country
_____ Job Title	_____ Zip/Postal Code
_____ Address	_____ Telephone Number with Area Code

Please list the system controller, operating system, programming language, and plug-in modules you are using.

fold here



NO POSTAGE
NECESSARY
IF MAILED
IN THE
UNITED STATES



POSTAGE WILL BE PAID BY ADDRESSEE

HEWLETT-PACKARD COMPANY
Measurement Systems Division
Learning Products Department
P.O. Box 301
Loveland, CO 80539-9984



cut along this line



fold here

Please pencil-in one circle for each statement below:

- The documentation is well organized.
- Instructions are easy to understand.
- The documentation is clearly written.
- Examples are clear and useful.
- Illustrations are clear and helpful.
- The documentation meets my overall expectations.

Disagree	←————→			Agree
<input type="radio"/>	<input type="radio"/>	<input type="radio"/>	<input type="radio"/>	<input type="radio"/>
<input type="radio"/>	<input type="radio"/>	<input type="radio"/>	<input type="radio"/>	<input type="radio"/>
<input type="radio"/>	<input type="radio"/>	<input type="radio"/>	<input type="radio"/>	<input type="radio"/>
<input type="radio"/>	<input type="radio"/>	<input type="radio"/>	<input type="radio"/>	<input type="radio"/>
<input type="radio"/>	<input type="radio"/>	<input type="radio"/>	<input type="radio"/>	<input type="radio"/>

Please write any comments or suggestions below—be specific.



Chapter 1

General Information

Introduction

This manual contains information required to test, troubleshoot, and repair the HP E1445A C-Size VXI Arbitrary Function Generator (AFG). See the *HP E1445A User's Manual* for additional information. Figure 1-1 shows the HP E1445A. This chapter includes the following sections:

- Introduction
- Safety Considerations
- Inspection/Shipping
- Environment
- AFG Description
- Recommended Test Equipment

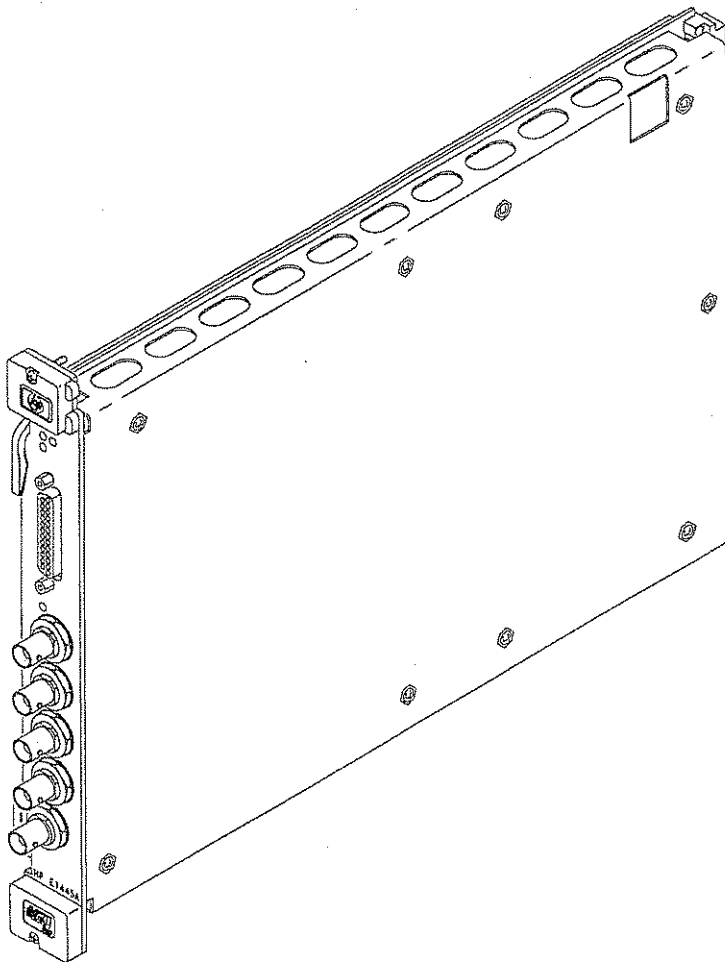

Figure 1-1. HP E1445A Arbitrary Function Generator

Safety Considerations

This product is a Safety Class I instrument that is provided with a protective earth terminal when installed in the mainframe. The mainframe, AFG, and all related documentation should be reviewed for familiarization with safety markings and instructions before operation or service.

Refer to the WARNINGS page (page 4) in this manual for a summary of safety information. Safety information for preventive maintenance, testing, and service follows and is also found throughout this manual.

Warnings and Cautions

This section contains WARNINGS which must be followed for your protection and CAUTIONS which must be followed to avoid damage to the equipment when performing instrument maintenance or repair.

WARNING

SERVICE-TRAINED PERSONNEL ONLY. The information in this manual is for service-trained personnel who are familiar with electronic circuitry and are aware of the hazards involved. To avoid personal injury or damage to the instrument, do not perform procedures in this manual or do any servicing unless you are qualified to do so.

CHECK MAINFRAME POWER SETTINGS. Before applying power, verify that the mainframe setting matches the line voltage and that the correct fuse is installed. An uninterruptible safety earth ground must be provided from the main power source to the supplied power cord set.

GROUNDING REQUIREMENTS. Interruption of the protective (grounding) conductor (inside or outside the mainframe) or disconnecting the protective earth terminal will cause a potential shock hazard that could result in personal injury. (Grounding one conductor of a two-conductor outlet is not sufficient protection.)

IMPAIRED PROTECTION. Whenever it is likely that instrument protection has been impaired, the mainframe must be made inoperative and be secured against any unintended operation.

REMOVE POWER IF POSSIBLE. Some procedures in this manual may be performed with power supplied to the mainframe while protective covers are removed. Energy available at many points may, if contacted, result in personal injury. (If maintenance can be performed without power applied, the power should be removed.)

WARNING

USING AUTOTRANSFORMERS. If the mainframe is to be energized via an autotransformer (for voltage reduction) make sure the common terminal is connected to neutral (that is, the grounded side of the main's supply).

CAPACITOR VOLTAGES. Capacitors inside the mainframe may remain charged even when the mainframe has been disconnected from its source of supply.

USE PROPER FUSES. For continued protection against fire hazard, replace the line fuses only with fuses of the same current rating and type (such as normal blow, time delay, etc.). Do not use repaired fuses or short-circuited fuseholders.

CAUTION

Static electricity is a major cause of component failure. To prevent damage to the electrical components in the AFG, observe anti-static techniques whenever working on the AFG.

Inspection/ Shipping

Initial Inspection

This section describes initial (incoming) inspection and shipping guidelines for the AFG.

Use the steps in Figure 1-2 as guidelines to perform initial inspection of the AFG.

WARNING

To avoid possible hazardous electrical shock, do not perform electrical tests if there are signs of shipping damage to the shipping container or to the instrument.

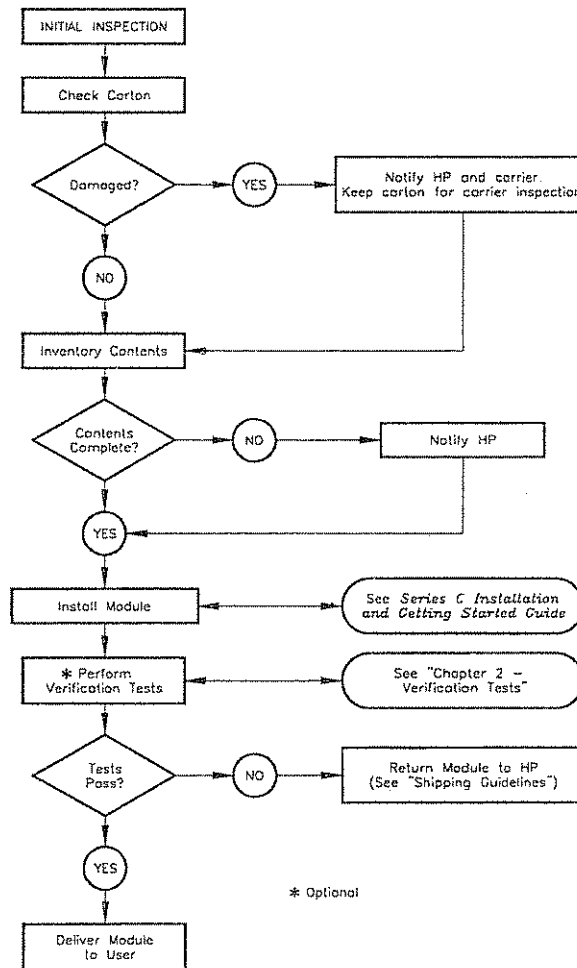
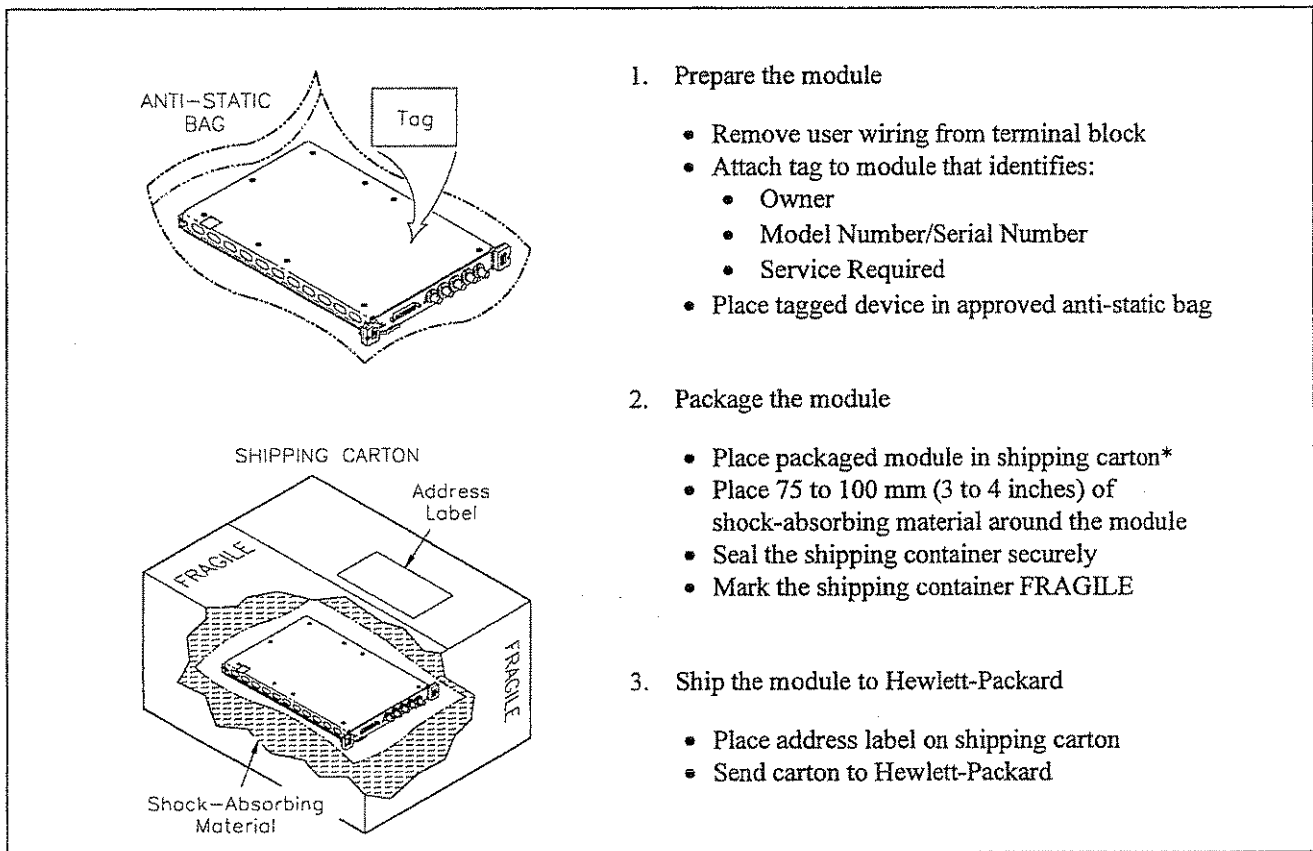

Figure 1-2. Initial (Incoming) Inspection Guidelines

Shipping Guidelines

Follow the steps in Figure 1-3 to return the AFG to a Hewlett-Packard Sales and Support Office or Service Center.



* We recommend that you use the same shipping materials as those used in factory packaging (available from Hewlett-Packard). For other (commercially-available) shipping materials, use a double-wall carton with minimum 2.4 MPa (350 psi) test.

Figure 1-3. Packaging/Shipping Guidelines

Environment

The recommended operating environment for the HP E1445A AFG is:

Environment	Temperature	Humidity
Operating	0°C to +55°C	<65% relative (0°C to +40°C)
Storage and Shipment	-40°C to +75°C	<65% relative (0°C to +40°C)

AFG Description

The HP E1445A Arbitrary Function Generator is a VXIbus C-size, message-based instrument. The AFG can operate in a C-size VXIbus mainframe using an HP E1405/E1406 Command Module and Standard Commands for Programmable Instruments (SCPI).

The AFG has 13 bits of resolution (including sign). It uses a sequencer architecture, with 256K points of Segment storage and 32K points of Sequence storage. The AFG has two internal timebases, 40 MHz and (approximately) 42.9 MHz.

AFG Specifications

AFG specifications are listed in Appendix A of the *HP E1445A User's Manual*. These specifications are the performance standards or limits against which the instrument may be tested.

AFG Options

Arbitrary Waveform Generation Software for HP 9000 Series 300 computers can be ordered as Option 005.

AFG Serial Numbers

Figure 1-4 shows Hewlett-Packard's serial number structure. AFG's covered by this manual are identified by a serial number prefix listed on the title page.

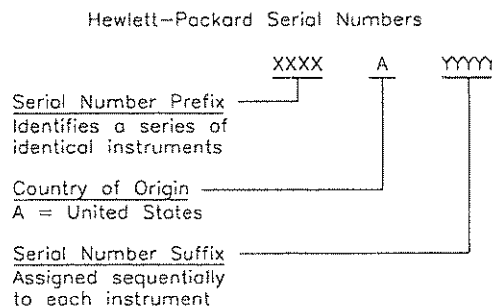

Figure 1-4. Hewlett-Packard Serial Numbers

Recommended Test Equipment

Table 1-1 lists the test equipment recommended for testing, adjusting, and servicing the AFG. Essential requirements for each piece of test equipment are described in the Requirements column.

Table 1-1. Recommended Test Equipment

Instrument	Requirements	Recommended Model	Use*
Controller, HP-IB	HP-IB compatibility as defined by IEEE Standard 488-1988 and the identical ANSI Standard MC1.1: SH1, AH1, T2, TE0, L2, LE0, SR0, RL0, PP0, DC0, DT0, and C1, 2, 3, 4, 5.	HP 9000 Series 300 or IBM Compatible PC with HP BASIC	F,O,P, A,T
Mainframe	Compatible with AFG	HP E1401B/T or E1421B	F,O,P, A,T
Command Module	10 MHz Clk Out TTL compatible Trig Out	HP E1405B or HP E1406A	F,O,P, A,T
Digital Multimeter	DCV, ACV, 4-wire ohms w/offset comp	HP 3458A	O,P,A
Power Meter	Frequency Range: 400 kHz - 10.8 MHz	HP 8902A	O,P,A
Power Sensor	Frequency Range: 400 kHz - 10.8 MHz	HP 11722A	O,P,A
Counter	Frequency Range: 100 Hz - 45 MHz	HP 5334A/B	O,P
Spectrum Analyzer	Frequency Range: 100 kHz - 150 MHz	HP 8566B	O,P,A
Oscilloscope	General Purpose Bandwidth: 20 MHz	HP 54111D	F
50 Ω feed-thru termination	50 \pm 0.10 Ω	HP 11048C	O,P,A

* F = Functional Verification, O = Operation Verification Tests, P = Performance Verification Tests, A = Adjustments, T = Troubleshooting



Chapter 2

Verification Tests

Introduction

The three levels of test procedures described in this chapter are used to verify that the HP E1445A:

- is fully functional (Functional Verification)
- meets selected testable specifications (Operation Verification)
- meets all testable specifications (Performance Verification)

WARNING

Do not perform any of the following verification tests unless you are a qualified, service-trained technician and have read the WARNINGS and CAUTIONS in Chapter 1.

Test Conditions/ Procedures

See Table 1-1 for test equipment requirements. You should complete the Performance Verification tests at least once a year. For heavy use or severe operating environments, perform the tests more often.

Before performing these tests, allow the AFG to warm up for at least one hour. The temperature should be within $\pm 5^{\circ}\text{C}$ of T_{cal} (the temperature of the most recent calibration), and between 18°C and 28°C .

The verification tests assume that the person performing the tests understands how to operate the mainframe, the AFG, and specified test equipment. The test procedures do not specify equipment settings for test equipment, except in general terms. It is assumed that a qualified, service-trained technician will select and connect the cables, adapters, and probes required for the test.

Performance Test Record

The results of each Performance Verification test may be recorded in Table 2-11, *HP E1445A Performance Test Record*. This form can be copied.

Verification Test Examples

Each verification test procedure includes an example program that performs the test. All example programs assume the following configuration:

- Controller is an HP 9000 Series 200/300 computer
- Programming language is HP BASIC
- AFG address is 70910

Command Coupling

Many of the AFG SCPI commands are value-coupled. In order to prevent "Settings Conflict" errors, coupled commands must be sent contiguously by placing them in the same program line, or by suppressing the end-of-line terminator. (For more information on command coupling and syntax, see Chapter 1 of the *HP E1445A User's Manual*). In HP BASIC, the end-of-line terminator can be suppressed by linking the commands with a semi-colon (;) and a colon (:), as illustrated below:

```
ROSC:SOUR INT1;  
:TRIG:SOUR INT1
```

In the Example programs, these commands would appear as follows:

```
OUTPUT 70910,"ROSC:SOUR:INT1;";  
OUTPUT 70910,":TRIG:SOUR:INT1"
```

Functional Verification

The purpose of these tests is to verify that the AFG is functioning properly and that all front panel inputs and outputs are working. No attempt is made to verify that the AFG is meeting specifications. Functional Verification for the AFG includes the following tests:

- Self-Test
- Ref In/Marker Out Test
- Start Arm In Test
- Gate In Test
- Output Relay Test

NOTE

For a quick functional check of the AFG, perform only the Self-Test.

An example program that performs all of the Functional Verification tests is included at the end of this section. An HP E1405/E1406 Command Module is required for this program.

NOTE

Some of the tests use the "TRIG OUT" port of the Command Module. This port uses negative logic, i.e., the high voltage is a logical 0 and the low voltage is a logical 1.

Functional Verification: Self-Test

Description

The AFG self-test performs the following internal checks:

- internal interrupt lines
- waveform select RAM
- segment sequence RAM
- waveform segment RAM
- DDS/NCO operation
- sine wave generation
- arbitrary waveform generation
- marker generation
- waveform cycle and arm counters
- sweep timer
- frequency-shift keying
- stop trigger
- DC analog parameters (amplitude, offset, attenuators, filters, calibration DACs)

Test Procedure

1. Remove any connections to the AFG front panel.

2. Reset the AFG:

`*RST;*CLS`

Reset AFG and clear status registers

3. Execute the AFG self-test:

`*TST?`

Self-test command

4. Read the result. A "0" indicates that the test passed. A "1" indicates a failure. Read the error queue using the SYST:ERR? command until the error message is "No error".

Functional Verification: Ref In/Marker Out Test

Description

The purpose of this test is to check the Ref/Sample In and Marker Out ports. An external reference is connected to the Ref/Sample In port and sent to the Marker Out port.

Test Procedure

1. Reset the AFG:

```
*RST;*CLS
```

Reset AFG and clear status registers

2. Set up equipment as shown in Figure 2-1:

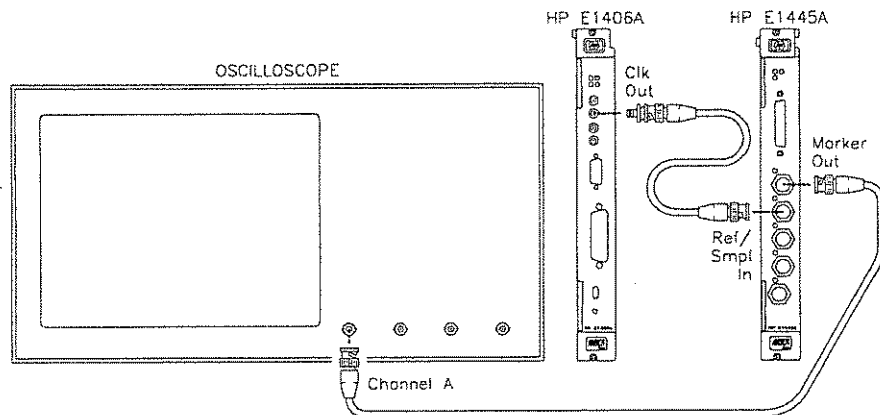

Figure 2-1. Ref/Sample In Test Setup

3. Set up the AFG to output the external reference to the "Marker Out" port:

```
ROSC:SOUR EXT  
MARK:FEED "ROSC"  
INIT:IMM
```

*External ref oscillator
Marker source is ROSC
Initiate*

4. Verify that the scope shows a 10 MHz squarewave.

Functional Verification: Start Arm In Test

Description

The purpose of this test is to check the Start Arm In port. The "TRIG OUT" port of the Command Module is used to send a Start Arm signal to the AFG.

Test Procedure

1. Reset the AFG:

```
*RST;*CLS
```

Reset AFG and clear status registers

2. Set up equipment as shown in Figure 2-2:

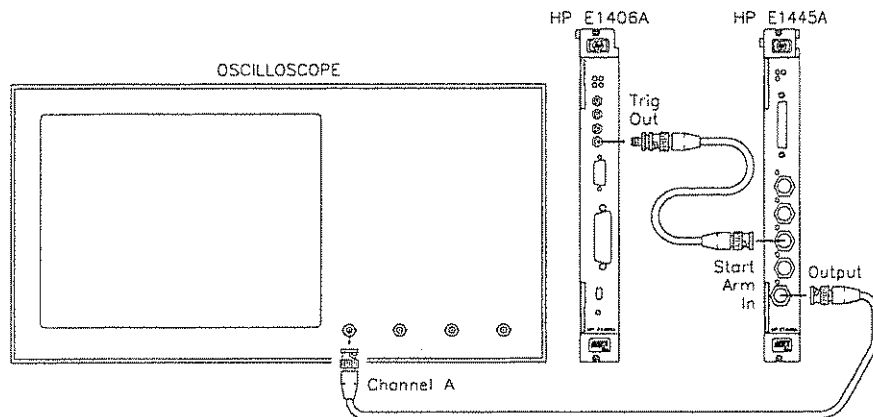

Figure 2-2. Start Arm In Test Setup

3. Send the following commands to the Command Module to output 0 V to the "Trig Out" port:

```
*RST  
OUTP:EXT:STAT ON  
OUTP:EXT:SOUR INT  
OUTP:EXT:LEV 1
```

Functional Verification: Start Arm In Test (cont'd)

Test Procedure (cont'd)

4. Set up the AFG to output a 1 MHz sinewave, with an external Start Arm source:

```
FREQ 1E6;  
:VOLT 4VPP  
ARM:LAY2:SOUR EXT
```

*Set freq to 1 MHz
Set AFG amplitude
External Start Arm
source*

```
INIT:IMM
```

Initiate

5. Verify that no signal appears on the scope. Send the following command to the Command Module to provide a Start Arm signal to the AFG:

```
OUTP:EXT:LEV 0
```

6. Verify that a 1 MHz sinewave appears on the scope.

Functional Verification: Gate In Test

Description

The purpose of this test is to check the gating function. The "TRIG OUT" port of the Command Module is used to gate the output.

Test Procedure

1. Reset the AFG:

*RST;*CLS

Reset AFG and clear status registers

2. Set up the equipment as shown in Figure 2-3.

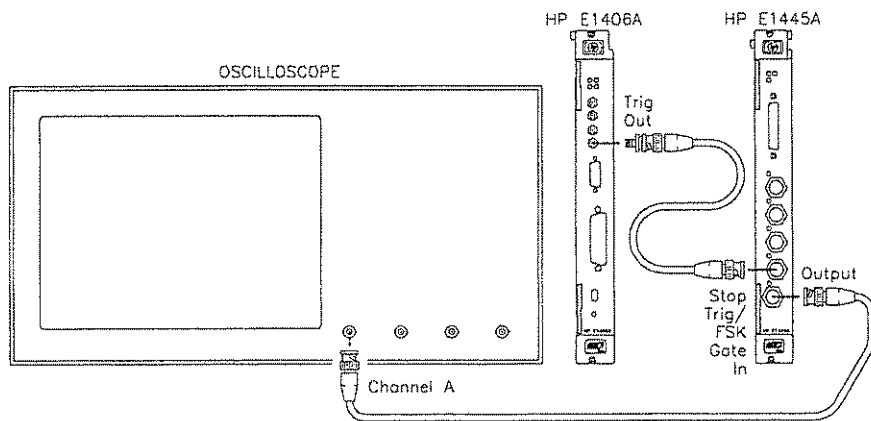

Figure 2-3. Gate In Test Setup

3. Send the following commands to the Command Module to enable the "Trig Out" port:

*RST
OUTP:EXT:STAT ON
OUTP:EXT:SOUR INT

Functional Verification: Gate In Test (cont'd)

Test Procedure (cont'd)

4. Set up the AFG to output a 1 MHz sinewave with an external gate source:

TRIG:GATE:SOUR EXT;	<i>External gate source</i>
:TRIG:GATE:STAT ON;	<i>Enable gate</i>
:FREQ 1E6;	<i>Set freq to 1 MHz</i>
:VOLT 4VPP	<i>Set AFG amplitude</i>
INIT:IMM	<i>Initiate</i>

5. Send the following command to the Command Module to set the level at the "Trig Out" port to 5 V. Verify that the scope shows a 1 MHz sinewave.

OUTP:EXT:LEV 0

6. Send the following command to the Command Module to set the level at the "Trig Out" port to 0 V. Verify that the scope shows a DC signal.

OUTP:EXT:LEV 1

Functional Verification: Output Relay Test

Description

The purpose of this test is to check the output relay.

Test Procedure

1. Reset the AFG:

```
*RST;*CLS
```

Reset AFG and clear status registers

2. Set up equipment as shown in Figure 2-4:

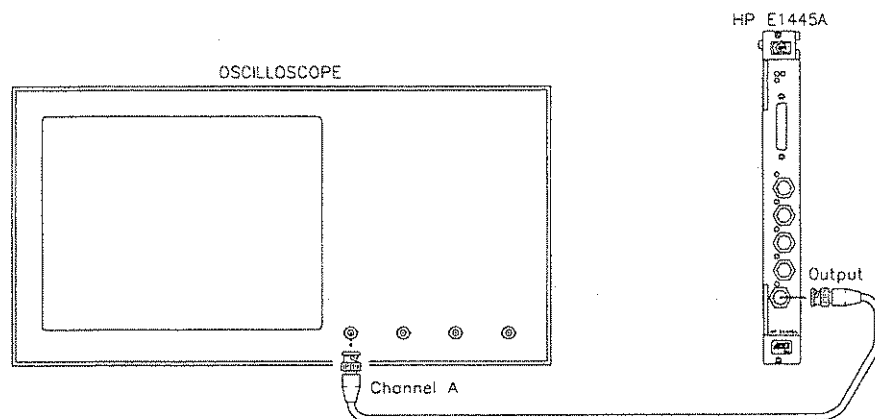

Figure 2-4. Output Relay Test Setup

3. Set up the AFG to output a 1 MHz sinewave:

```
FREQ 1E6;  
:VOLT 4VPP  
INIT:IMM
```

*Set freq to 1 MHz
Set AFG amplitude
Initiate*

4. Verify that a 1 MHz sinewave appears on the scope.
5. Disable the Output relay:

```
OUTP OFF
```

6. Verify that no signal appears on the scope.

Functional Verification

Example Program

This program performs the Functional Verification Tests for the AFG. An HP E1405/E1406 Command Module is required for this test.

```
10! RE-STORE "FUNC_TEST"
20 COM @Afg,@Cmd_mod,INTEGER Done
30 !
40 !----- Set up I/O paths -----
50 ASSIGN @Afg TO 70910
60 ASSIGN @Cmd_mod TO 70900
70 !
80 !----- Initialize AFG & Command Module -----
90 Reset_afg
100 !
110 !Set up Command Module 'TRIG OUT' port
120 OUTPUT @Cmd_mod;"*RST"
130 OUTPUT @Cmd_mod;"OUTP:EXT:STAT ON"
140 OUTPUT @Cmd_mod;"OUTP:EXT:SOUR INT"
150 !
160 !----- Perform tests -----
170 CLEAR SCREEN
180 PRINT "HP E1445A FUNCTIONAL VERIFICATION TESTS"
190 PRINT
200 !
210 !Oscilloscope settings
220 PRINT "Set scope to: 2 V/div, .02 usec/div"
230 PRINT
240 Wait_for_cont
250 !
260 CALL Self_test                !Self-Test
270 CALL Ref_in                  !Ref In/Marker Out Test
280 !
290 !Oscilloscope settings
300 CLEAR SCREEN
310 PRINT "Set scope to: 2 V/div, .2 usec/div"
320 PRINT
330 Wait_for_cont
340 !
350 CALL Start_arm               !Start Arm In Test
360 CALL Gate_in                !Gate In Test
370 CALL Output_relay           !Output Relay Test
380 !
390 Quit: !
400 Reset_afg
410 CLEAR SCREEN
420 DISP "Functional Tests completed."
430 END
```

(Continued on next page)

Functional Verification

Example Program (cont'd)

```
450 !----- Subprograms -----
460 SUB Reset_afg
470   COM @Afg,@Cmd_mod,INTEGER Done
480   OUTPUT @Afg;"*RST;*CLS"           !Reset AFG and clear Status register
490   WAIT 1
500 SUBEND
510 !
520 SUB Self_test
530   COM @Afg,@Cmd_mod,INTEGER Done
540   DIM Message$[255]
550   !
560   Reset_afg
570   !
580   CLEAR SCREEN
590   PRINT "SELF-TEST"
600   PRINT
610   !
620   !Test connections
630   PRINT "Remove any connections from the E1445A front panel."
640   PRINT "Press 'Continue' to initiate Self-Test."
650   PRINT
660   Wait_for_cont
670   !
680   !Perform test
690   OUTPUT @Afg;"*TST?"             !Self-test command
700   ENTER @Afg;Result              !Get result
710   !
720   IF Result=0 THEN
730     PRINT "Self-test passed."
740   ELSE
750     PRINT "Self-test failed."
760     PRINT "The following error(s) occurred:"
770     REPEAT
780       OUTPUT @Afg;"SYST:ERR?"     !Check for errors
790       ENTER @Afg;Message$
800       PRINT "  "&Message$
810     UNTIL POS(Message$,"No error")
820   END IF
830   Wait_for_cont
840 SUBEND
850 !
860 SUB Ref_in
870   COM @Afg,@Cmd_mod,INTEGER Done
880   !
```

(Continued on next page)

Functional Verification

Example Program (cont'd)

```
890 Reset_afg
900 !
910 CLEAR SCREEN
920 PRINT "REF IN/MARKER OUT TEST"
930 PRINT
940 !
950 !Test connections
960 PRINT "Connect Scope to 'Marker Out' on the E1445A."
970 PRINT "Connect Command Module 'Clk Out' to 'Ref/Sample In' on the E1445A."
980 PRINT
990 Wait_for_cont
1000 !
1010 !Perform test
1020 OUTPUT @Afg;"ROSC:SOUR EXT"           !External ref osc source
1030 OUTPUT @Afg;"MARK:FEED ""ROSC""     !Marker source is 'ROSC'
1040 OUTPUT @Afg;"INIT:IMM"             !Initiate
1050 !
1060 PRINT "Verify that the scope shows a 10 MHz squarewave."
1070 Wait_for_cont
1080 SUBEND
1090 !
1100 SUB Start_arm
1110 COM @Afg,@Cmd_mod,INTEGER Done
1120 !
1130 Reset_afg
1140 !
1150 CLEAR SCREEN
1160 PRINT "START ARM TEST"
1170 PRINT
1180 !
1190 !Test connections
1200 PRINT "Connect Scope to the E1445A Output."
1210 PRINT "Connect Command Module 'Trig Out' to 'Start Arm In' on the E1445A."
1220 PRINT
1230 Wait_for_cont
1240 !
1250 !Set Command Module's 'TRIG OUT' to 0V (E1405 uses neg logic)
1260 OUTPUT @Cmd_mod;"OUTP:EXT:LEV 1"
1270 !
1280 !Perform test
1290 OUTPUT @Afg;"FREQ 1E6;";           !Set freq to 1 MHz
1300 OUTPUT @Afg;":VOLT 4VPP"         !Set amplitude
1310 OUTPUT @Afg;"ARM:LAY2:SOUR EXT"   !Start Arm source is EXT
1320 OUTPUT @Afg;"INIT:IMM"           !Initiate
1330 !
```

(Continued on next page)

Functional Verification

Example Program (cont'd)

```
1340 PRINT "Verify that no signal appears on the scope."
1350 PRINT "Press 'Continue' to send a START ARM."
1360 PRINT
1370 Wait_for_cont
1380 !
1390 !Set 'TRIG OUT' to 5V
1400 OUTPUT @Cmd_mod;"OUTP:EXT:LEV 0"
1410 !
1420 PRINT "Verify that the scope shows a 1 MHz sinewave."
1430 Wait_for_cont
1440 SUBEND
1450 !
1460 SUB Gate_in
1470 COM @Afg,@Cmd_mod,INTEGER Done
1480 !
1490 Reset_afg
1500 !
1510 CLEAR SCREEN
1520 PRINT "GATE IN TEST"
1530 PRINT
1540 !
1550 !Test connections
1560 PRINT "Connect Scope to the E1445A Output."
1570 PRINT "Connect Command Module 'Trig Out' to 'Stop Trig/FSK/Gate In' on the E1445A."
1580 PRINT
1590 Wait_for_cont
1600 !
1610 !Perform test
1620 OUTPUT @Afg;"TRIG:GATE:SOUR EXT;";           !Gate source is EXT
1630 OUTPUT @Afg;".TRIG:GATE:STAT ON;";         !Enable gate
1640 OUTPUT @Afg;".FREQ 1E6;";                   !Set freq to 1 MHz
1650 OUTPUT @Afg;".VOLT 4VPP"                   !Set amplitude
1660 OUTPUT @Afg;"INIT:IMM"                       !!Initiate
1670 !
1680 PRINT "Verify that the signal displayed on the scope toggles between"
1690 PRINT "a 1 MHz sinewave and a DC signal at 1 second intervals."
1700 !
1710 ON KBD ALL CALL Key_press
1720 DISP "Press any key to continue"
1730 !
1740 Done=0
1750 !Send pulses to 'TRIG OUT' BNC until a key is pressed
```

(Continued on next page)

Functional Verification

Example Program (cont'd)

```
1760 REPEAT
1770   OUTPUT @Cmd_mod;"OUTP:EXT:LEV 1"
1780   WAIT 1
1790   OUTPUT @Cmd_mod;"OUTP:EXT:LEV 0"
1800   WAIT 1
1810   UNTIL Done
1820   OFF KBD
1830 SUBEND
1840 !
1850 SUB Output_relay
1860 COM @Afg,@Cmd_mod,INTEGER Done
1870 !
1880 Reset_afg
1890 !
1900 CLEAR SCREEN
1910 PRINT "OUTPUT RELAY TEST"
1920 PRINT
1930 !
1940 !Test connections
1950 PRINT "Connect Scope to the E1445A Output."
1960 PRINT
1970 Wait_for_cont
1980 !
1990 !Perform test
2000 OUTPUT @Afg;"FREQ 1E6;";           !Set freq to 1 MHz
2010 OUTPUT @Afg;":VOLT 4VPP"         !Set amplitude
2020 OUTPUT @Afg;"INIT:IMM"          !Initiate
2030 !
2040 PRINT "Verify that the scope shows a 1 MHz sinewave."
2050 PRINT "Press 'Continue' to disable the E1445A output."
2060 PRINT
2070 Wait_for_cont
2080 !
2090 OUTPUT @Afg;"OUTP OFF"           !Open Output relay
2100 PRINT "Verify that no signal appears on the scope."
2110 Wait_for_cont
2120 SUBEND
2130 !
```

(Continued on next page)

Functional Verification

Example Program (cont'd)

```
2140 SUB Key_press
2150 COM @Afg,@Cmd_mod,INTEGER Done
2160 Done=1
2170 DISP
2180 SUBEND
2190 !
2200 SUB Wait_for_cont
2210 DISP "Press 'Continue' when ready"
2220 PAUSE
2230 DISP
2240 SUBEND
```

Operation Verification

Operation Verification is a subset of the Performance Verification tests that follow. For the AFG, Operation Verification consists of the following tests:

- DC Accuracy
- AC Accuracy
- Total Harmonic Distortion

Performance Verification

The procedures in this section are used to test the AFG's electrical performance using the specifications in Appendix A of the *HP E1445A User's Manual* as the performance standards. These tests are suitable for incoming inspection, troubleshooting, and preventive maintenance. The results of the Performance Verification tests should be recorded in the Performance Test Record (Table 2-11).

Performance Verification includes the following tests:

Test #	Test Name
2-1	DC Zeros
2-2	DC Accuracy
2-3	DC Offset
2-4	AC Accuracy
2-5	AC Flatness - 250 kHz filter
2-6	AC Flatness - 10 MHz filter
2-7	Frequency Accuracy
2-8	Duty Cycle
2-9	Total Harmonic Distortion
2-10	Spurious/Non-harmonic Distortion

Test 2-1: DC Zeros

Description

The purpose of this test is to verify that the AFG meets its specifications for DCV accuracy for an output of zero volts. An arbitrary waveform consisting of zeros is used. The amplitude is varied in order to test each attenuator.

Equipment Setup

- Connect equipment as shown in Figure 2-5
- Set DMM to: DCV, 100 mV range

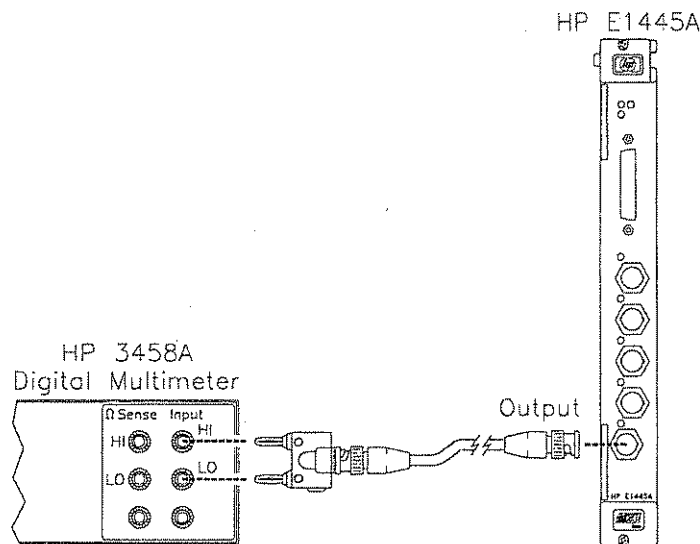

Figure 2-5. Equipment Setup for Test 2-1 thru Test 2-4

Test Procedure

1. Reset the AFG:

*RST;*CLS

Reset AFG and clear status registers

2. Delete all sequences and segments from memory:

LIST:SSEQ:DEL:ALL
LIST:SEGM:DEL:ALL

Delete all sequences
Delete all segments

Test 2-1: DC Zeros (cont'd)

Test Procedure (cont'd)

3. Create a user-defined waveform made up of zeros:

LIST:SEGM:SEL ZEROS	<i>Select segment name</i>
LIST:SEGM:DEF 8	<i># of segment points</i>
LIST:SEGM:VOLT 0,0,0,0,0,0,0,0	<i>Segment list</i>
LIST:SSEQ:SEL DC_ZEROS	<i>Select sequence name</i>
LIST:SSEQ:DEF 1	<i># of segments</i>
LIST:SSEQ:SEQ ZEROS	<i>Sequence list</i>

4. Set up the AFG to output the waveform defined above:

ROSC:SOUR CLK10;	<i>Select 10 MHz clock</i>
:VOLT MAX;	<i>Set amplitude</i>
:OUTP:LOAD INF;	<i>Infinite load</i>
:FUNC USER	<i>Select user waveform</i>
FUNC:USER DC_ZEROS	<i>Select sequence</i>
INIT:IMM	<i>Initiate waveform</i>

Perform steps 5 - 7 for each amplitude listed in Table 2-1:

5. Set the AFG output filter as specified in Table 2-1. Use the appropriate command(s) below:

OUTP:FILT OFF	<i>Disable filter</i>
or	
OUTP:FILT:FREQ 250KHZ	<i>Select 250 kHz filter</i>
OUTP:FILT ON	<i>Enable filter</i>
or	
OUTP:FILT:FREQ 10MHZ	<i>Select 10 MHz filter</i>
OUTP:FILT ON	<i>Enable filter</i>

6. Set the AFG output amplitude:

VOLT <amplitude>	<i>Set amplitude</i>
------------------	----------------------

where <amplitude> is the value specified in Table 2-1.

7. Trigger the DMM and record the reading in Table 2-11.

Test 2-1: DC Zeros (cont'd)

Test Procedure (cont'd)

Table 2-1. DC Zeros Test Points

Attenuation (dB)	Amplitude (volts)	Filter	Test Limits (volts)
0	10.23750	None	0 ± 0.0220
.99	9.13469	None	0 ± 0.0220
1	9.12416	None	0 ± 0.0220
2	8.13192	None	0 ± 0.0220
4	6.45941	None	0 ± 0.0220
8	4.07560	None	0 ± 0.0220
13	2.29187	None	0 ± 0.0220
14	2.04263	None	0 ± 0.0044
30	0.32372	None	0 ± 0.0044
0	10.23750	250 kHz	0 ± 0.0220
.99	9.13469	250 kHz	0 ± 0.0220
1	9.12416	250 kHz	0 ± 0.0220
2	8.13192	250 kHz	0 ± 0.0220
4	6.45941	250 kHz	0 ± 0.0220
8	4.07560	250 kHz	0 ± 0.0220
13	2.29187	250 kHz	0 ± 0.0220
14	2.04263	250 kHz	0 ± 0.0044
30	0.32372	250 kHz	0 ± 0.0044
0	10.23750	10 MHz	0 ± 0.0220
.99	9.13469	10 MHz	0 ± 0.0220
1	9.12416	10 MHz	0 ± 0.0220
2	8.13192	10 MHz	0 ± 0.0220
4	6.45941	10 MHz	0 ± 0.0220
8	4.07560	10 MHz	0 ± 0.0220
13	2.29187	10 MHz	0 ± 0.0220
14	2.04263	10 MHz	0 ± 0.0044
30	0.32372	10 MHz	0 ± 0.0044

Test 2-1: DC Zeros (cont'd)

Example Program

This program performs the DC Zeros test. An arbitrary waveform, consisting of zeros, is used with various amplitudes to test a variety of attenuator and filter combinations.

```
10! RE-STORE "DC_ZEROS"
20  COM @Afg
30  DIM Attn(1:9),Vout(1:9)
40  !
50  !----- Set up I/O path and reset AFG -----
60  ASSIGN @Afg TO 70910
70  OUTPUT @Afg;"*RST;*CLS"                !Reset AFG
80  !
90  !----- Initialize variables -----
100 DATA 0,.99,1,2,4,8,13,14,30
110 READ Attn(*)                          !Read in attenuations
120 !
130 DATA 10.2375,9.13469,9.12416,8.13192,6.45941,4.0756
140 DATA 2.29187,2.04263,0.32372
150 READ Vout(*)
160 !
170 !----- Set up DMM -----
180 PRINT "Set up DMM:"
190 PRINT
200 PRINT "  Function -- DCV"
210 PRINT "  Range -- 100 mV"
220 PRINT
230 PRINT "Connect DMM HI and LO to AFG Output."
240 DISP "Press 'Continue' when ready"
250 PAUSE
260 CLEAR SCREEN
270 !
280 !----- Set up AFG -----
290 OUTPUT @Afg;"*RST"                    !Reset AFG
300 OUTPUT @Afg;"LIST:SSEQ:DEL:ALL"      !Delete all sequences
310 OUTPUT @Afg;"LIST:SEGM:DEL:ALL"      !Delete all segments
320 WAIT .5
330 OUTPUT @Afg;"ROSC:SOUR CLK10;";      !10MHZ clock
340 OUTPUT @Afg;":VOLT MAX;";            !MAX output
350 OUTPUT @Afg;":OUTP:LOAD INF;";      !Infinite load
360 OUTPUT @Afg;":FUNC USER"            !User waveform
370 !
380 CALL Def_seq_zeros                    !Define waveform
390 OUTPUT @Afg;"FUNC:USER DC_ZEROS"     !Select sequence
400 OUTPUT @Afg;"INIT:IMM"
410 !
420 !----- Perform test -----
430 PRINT "ATTEN","FILTER","AMPLITUDE"
```

(Continued on next page)

Test 2-1: DC Zeros (cont'd)

Example Program (cont'd)

```
440 PRINT
460 FOR Filter=0 TO 2
470   SELECT Filter
480   CASE 0                               !No filter
490     OUTPUT @Afg;"OUTP:FILT OFF"
500     Filter$="NONE"
510   CASE 1                               !250KHZ filter
520     OUTPUT @Afg;"OUTP:FILT:FREQ 250KHZ"
530     OUTPUT @Afg;"OUTP:FILT ON"
540     Filter$="250 kHz"
550   CASE 2                               !10MHZ filter
560     OUTPUT @Afg;"OUTP:FILT:FREQ 10MHZ"
570     OUTPUT @Afg;"OUTP:FILT ON"
580     Filter$="10 MHz"
590   END SELECT
600   !
610   FOR I=1 TO 9                          !Loop through atten's
620     OUTPUT @Afg;":VOLT "&VAL$(Vout(I))   !Set AFG amplitude
630     PRINT Attn(I),Filter$,Vout(I)
640     !
650     DISP "Record DMM reading, then press 'Continue'"
660     PAUSE
670     DISP
680   NEXT I                                !Next attenuation
690   PRINT
700 NEXT Filter                             !Next filter
710 !
720 OUTPUT @Afg;"*RST;*CLS"                !Reset AFG
730 END
740 !
750 SUB Def_seq_zeros
760   COM @Afg
770   OUTPUT @Afg;"LIST:SEGM:SEL ZEROS"     !Segment name
780   OUTPUT @Afg;"LIST:SEGM:DEF 8"        !Segment length
790   OUTPUT @Afg;"LIST:SEGM:VOLT 0,0,0,0,0,0,0" !Voltage points
800   !
810   OUTPUT @Afg;"LIST:SSEQ:SEL DC_ZEROS" !Sequence name
820   OUTPUT @Afg;"LIST:SSEQ:DEF 1"        !# of segments
830   OUTPUT @Afg;"LIST:SSEQ:SEQ ZEROS"    !Segment list
840 SUBEND
```

Test 2-2: DC Accuracy

Description

The purpose of this test is to verify that the AFG meets its specifications for DC accuracy.

Equipment Setup

- Connect equipment as shown in Figure 2-5
- Set DMM to DCV, autorange

Test Procedure

1. Reset the AFG:

*RST;*CLS

Reset AFG and clear status registers

2. Set up the AFG to output a DC signal:

FUNC DC;
:OUTP:LOAD INF;
:VOLT MAX

*Select DC waveform
Infinite load
Set amplitude*

Perform steps 3 - 5 for each amplitude listed in Table 2-2:

3. Set up the AFG output filter as specified in Table 2-2. Use the appropriate command(s) below:

OUTP:FILT OFF

Disable filter

or

OUTP:FILT:FREQ 250KHZ
OUTP:FILT ON

*Select 250 kHz filter
Enable filter*

or

OUTP:FILT:FREQ 10MHZ
OUTP:FILT ON

*Select 10 MHz filter
Enable filter*

4. Set the AFG output amplitude:

VOLT <amplitude>

Set amplitude

where <amplitude> is the value specified in Table 2-2.

5. Trigger the DMM and record the reading.

Test 2-2: DC Accuracy (cont'd)

Test Procedure (cont'd)

Table 2-2. DC Accuracy Test Points

Amplitude (volts)	Filter	Test Limits (volts)
10.2375	None	10.2375 ± 0.0512
5.0	None	5.0 ± 0.0355
0.0	None	0.0 ± 0.0205
-5.0	None	-5.0 ± 0.0355
-10.24	None	-10.24 ± 0.0512
10.2375	250 kHz	10.2375 ± 0.0512
-10.24	250 kHz	-10.24 ± 0.0512
10.2375	10 MHz	10.2375 ± 0.0512
-10.24	10 MHz	10.24 ± 0.0512

Example Program

This program performs the DC Accuracy test.

```
10! RE-STORE "DC_LEVELS"
20 DIM Vout(1:9),Filter(1:9)
30 !
40 !----- Set up I/O path and reset AFG -----
50 ASSIGN @Afg TO 70910
60 OUTPUT @Afg;"*RST;*CLS" !Reset AFG
70 !
80 !----- Initialize variables -----
90 DATA 10.2375,5.0,0,-5.0,-10.24,10.2375,-10.24,10.2375,-10.24
100 READ Vout(*)
110 !
120 DATA 0,0,0,0,0,1,1,2,2
130 READ Filter(*)
140 !
150 !----- Set up DMM -----
160 CLEAR SCREEN
170 PRINT "Set up DMM:"
180 PRINT
190 PRINT " Function -- DCV"
200 PRINT " Range -- AUTO"
210 PRINT
220 PRINT "Connect DMM HI and LO to AFG Output."
230 DISP "Press 'Continue' when ready"
240 PAUSE
250 CLEAR SCREEN
```

(Continued on next page)

Test 2-2: DC Accuracy (cont'd)

Example Program (cont'd)

```
270  |----- Set up AFG -----
280  OUTPUT @Afg;"*RST"                !Reset AFG
290  WAIT .5
300  OUTPUT @Afg;"FUNC DC;";           IDC function
310  OUTPUT @Afg;":OUTP:LOAD INF;";    !Infinite load
320  OUTPUT @Afg;":VOLT MAX"           !MAX output
330  !
340  |----- Perform test -----
350  PRINT "FILTER","AMPLITUDE"
360  PRINT
370  !
380  FOR I=1 TO 9
390    SELECT Filter(I)
400    CASE 0
410      OUTPUT @Afg;"OUTP:FILT OFF"    !No filter
420      Filter$="NONE"
430    CASE 1
440      OUTPUT @Afg;"OUTP:FILT:FREQ 250KHZ" !250kHz filter
450      OUTPUT @Afg;"OUTP:FILT ON"
460      Filter$="250 kHz"
470    CASE 2
480      OUTPUT @Afg;"OUTP:FILT:FREQ 10MHZ" !10MHz filter
490      OUTPUT @Afg;"OUTP:FILT ON"
500      Filter$="10 MHz"
510    END SELECT
520    !
530    OUTPUT @Afg;"VOLT "&VAL$(Vout(I)) !Set amplitude
540    PRINT Filter$,Vout(I)
550    !
560    DISP "Record DMM reading, then press 'Continue'"
570    PAUSE
580    DISP
590  NEXT I
600  !
610  OUTPUT @Afg;"*RST;*CLS"           !Reset AFG
620  END
```

Test 2-3: DC Offset

Description

The purpose of this test is to verify that the AFG meets its specifications for DC offset accuracy.

Equipment Setup

- Connect equipment as shown in Figure 2-5
- Set DMM to DCV, autorange

Test Procedure

1. Reset the AFG:

```
*RST;*CLS Reset AFG and clear status registers
```

2. Delete all sequences and segments from memory:

```
LIST:SSEQ:DEL:ALL Delete all sequences  
LIST:SEGM:DEL:ALL Delete all segments
```

3. Create a user-defined waveform made up of zeros:

```
LIST:SEGM:SEL ZEROS Select segment name  
LIST:SEGM:DEF 8 # of segment points  
LIST:SEGM:VOLT 0,0,0,0,0,0,0,0 Segment list  
  
LIST:SSEQ:SEL DC_ZEROS Select sequence name  
LIST:SSEQ:DEF 1 # of segments  
LIST:SSEQ:SEQ ZEROS Sequence list
```

4. Set up the AFG to output the waveform defined above:

```
ROSC:SOUR CLK10; Select 10 MHz clock  
:OUTP:LOAD INF; Infinite load  
:VOLT MAX; Set amplitude  
:FUNC USER Select user waveform  
FUNC:USER DC_ZEROS Select sequence  
INIT:IMM Initiate waveform
```

Test 2-3: DC Offset (cont'd)

Test Procedure (cont'd)

Perform steps 5 - 7 for each offset listed in Table 2-3:

5. If necessary, change the AFG output amplitude:

VOLT:OFFS 0; *Set offset to 0*
:VOLT <amplitude> *Set amplitude*

where <amplitude> is the value specified in Table 2-3.

6. Set AFG offset voltage:

VOLT:OFFS <offset> *Set offset*

where <offset> is the value specified in Table 2-3.

7. Trigger the DMM and record the reading.

Table 2-3. DC Offset Test Points

Offset (volts)	Amplitude (volts)	Test Limits (volts)
9.755	2.29189	9.755 ± 0.1196
4.000	2.29189	4.0 ± 0.0620
-4.000	2.29189	-4.0 ± 0.0620
-9.755	2.29189	-9.755 ± 0.1196
2.000	0.40756	2.0 ± 0.0244
-2.000	0.40756	-2.0 ± 0.0244

Test 2-3: DC Offset (cont'd)

Example Program

This program performs the DC Offset Test.

```
10! RE-STORE "DC_OFFSET"
20 COM @Afg
30 DIM Offset(1:6)
40 !
50 !----- Set up I/O path and reset AFG -----
60 ASSIGN @Afg TO 70910                                !AFG I/O path
70 OUTPUT @Afg;"*RST;*CLS"                             !Reset AFG
80 !
90 !----- Initialize variables -----
100 DATA 9.755,4.0,-4.0,-9.755,2.0,-2.0
110 READ Offset(*)                                     !Read in offsets
120 !
130 Vout_old=0                                         !Initialize
140 !
150 !----- Set up DMM -----
160 CLEAR SCREEN
170 PRINT "Set up DMM:"
180 PRINT
190 PRINT "  Function -- DCV"
200 PRINT "  Range -- AUTO"
210 PRINT
220 PRINT "Connect DMM HI and LO to AFG Output."
230 DISP "Press 'Continue' when ready"
240 PAUSE
250 CLEAR SCREEN
260 !
270 !----- Set up AFG -----
280 OUTPUT @Afg;"*RST"                                 !Reset AFG
290 OUTPUT @Afg;"LIST:SSEQ:DEL:ALL"                   !Delete all sequences
300 OUTPUT @Afg;"LIST:SEGM:DEL:ALL"                   !Delete all segments
310 WAIT .5
320 OUTPUT @Afg;"ROSC:SOUR CLK10;";                   !10MHz clock
330 OUTPUT @Afg;":OUTP:LOAD INF;";                   !Infinite load
340 OUTPUT @Afg;":VOLT MAX;";                         !MAX output
350 OUTPUT @Afg;":FUNC USER"                          !User waveform
360 !
370 CALL Def_seq_zeros                                 !Define sequence of zeros
380 OUTPUT @Afg;"FUNC:USER DC_ZEROS"                  !Select sequence
390 !
400 !----- Perform test -----
410 PRINT "AMPLITUDE"," OFFSET"
420 PRINT
430 !
```

(Continued on next page)

Test 2-3: DC Offset (cont'd)

Example Program (cont'd)

```
440 FOR I=1 TO 6
450   IF I<=4 THEN
460     Vout=2.2919
470   ELSE
480     Vout=.40756
490   END IF
500   !
510   IF Vout<>Vout_old THEN
520     !Set offset to zero before changing amplitude
530     OUTPUT @Afg;":VOLT:OFFS 0;";
540     OUTPUT @Afg;":VOLT "&VAL$(Vout)&";";
550   END IF
560   !
570   OUTPUT @Afg;":VOLT:OFFS "&VAL$(Offset(I))!Set offset
580   PRINT Vout,Offset(I)
590   !
600   DISP "Record DMM reading, then press 'Continue'"
610   PAUSE
620   DISP
630   Vout_old=Vout
640 NEXT I           !Next attenuation
650 !
660 OUTPUT @Afg;""RST;""CLS"           !Reset AFG
670 END
680 !
690 SUB Def_seq_zeros
700   COM @Afg
710   OUTPUT @Afg;"LIST:SEGM:SEL ZEROS"           !Segment name
720   OUTPUT @Afg;"LIST:SEGM:DEF 8"             !Segment length
730   OUTPUT @Afg;"LIST:SEGM:VOLT 0,0,0,0,0,0,0" !Voltage points
740   !
750   OUTPUT @Afg;"LIST:SSEQ:SEL DC_ZEROS"       !Sequence name
760   OUTPUT @Afg;"LIST:SSEQ:DEF 1"             !# of segments
770   OUTPUT @Afg;"LIST:SSEQ:SEQ ZEROS"         !Segment list
780 SUBEND
```

Test 2-4: AC Accuracy

Description

The purpose of this test is to verify that the AFG meets its specifications for AC accuracy at 1 kHz.

Equipment Setup

- Connect equipment as shown in Figure 2-5
- Set DMM to ACV, autorange

Test Procedure

1. Reset the AFG:

*RST;*CLS

Reset AFG and clear status registers

2. Set up the AFG to output a 1 kHz sinewave:

FREQ 1E3;
:VOLT MAX;
:OUTP:LOAD INF
CAL:STAT:AC OFF
INIT:IMM

*Set freq to 1 kHz
Set to max amplitude
Infinite load
AC corrections off
Initiate waveform*

Perform steps 3 - 5 for each amplitude and filter listed in Table 2-4:

3. Set up AFG output filter as specified in Table 2-4. Use the appropriate command(s) below:

OUTP:FILT OFF

Disable filter

or

OUTP:FILT:FREQ 250KHZ

Select 250 kHz filter

OUTP:FILT ON

Enable filter

or

OUTP:FILT:FREQ 10MHZ

Select 10 MHz filter

OUTP:FILT ON

Enable filter

Test 2-4: AC Accuracy (cont'd)

Test Procedure (cont'd)

4. Set the AFG output amplitude:

VOLT *<amplitude>*VRMS

Set amplitude

where *<amplitude>* is the value specified in Table 2-4.

5. Trigger the DMM and record the reading.

Table 2-4. AC Accuracy Test Points

Amplitude (volts rms)	Filter	Test Limits \pm (dB)
7.2390	None	0.10
6.4500	None	0.15
5.7500	None	0.15
4.5660	None	0.15
2.8818	None	0.15
1.4444	None	0.15
0.2290	None	0.15
7.2390	250 kHz	0.10
7.2390	10 MHz	0.10

Test 2-4: AC Accuracy (cont'd)

Example Program

This program performs the AC Accuracy Test.

```
10! RE-STORE "AC_LEVELS"
20 DIM Vout(1:9),Filter(1:9)
30 !
40 !----- Set up I/O path and reset AFG -----
50 ASSIGN @Afg TO 70910
60 OUTPUT @Afg;"*RST;*CLS"                !Reset AFG
70 !
80 !----- Initialize variables -----
90 DATA 7.239,6.45,5.75,4.566,2.8818,1.4444,.229,7.239,7.239
100 READ Vout(*)
110 !
120 DATA 0,0,0,0,0,0,0,1,2
130 READ Filter(*)
140 !
150 !----- Set up DMM -----
160 CLEAR SCREEN
170 PRINT "Set up DMM:"
180 PRINT
190 PRINT "  Function -- ACV"
200 PRINT "  Range -- AUTO"
210 PRINT
220 PRINT "Connect DMM HI and LO to AFG Output."
230 DISP "Press 'Continue' when ready"
240 PAUSE
250 CLEAR SCREEN
260 !
270 !----- Set up AFG -----
280 OUTPUT @Afg;"*RST"                    !Reset AFG
290 WAIT .5
300 OUTPUT @Afg;"FREQ 1E3;";              !Set freq to 1 kHz
310 OUTPUT @Afg;":VOLT MAX;";            !MAX amplitude
320 OUTPUT @Afg;":OUTP:LOAD INF"         !Infinite load
340 OUTPUT @Afg;"CAL:STAT:AC OFF"       !AC corrections off
350 OUTPUT @Afg;"INIT:IMM"              !Initiate
360 WAIT .5
370 !
380 !----- Perform test -----
390 PRINT "FILTER","AMPLITUDE"
400 PRINT
410 !
```

(Continued on next page)

Test 2-4: AC Accuracy (cont'd)

Example Program (cont'd)

```
420 FOR I=1 TO 9
430   SELECT Filter(I)
440   CASE 0
450     OUTPUT @Afg;"OUTP:FILT OFF"           !No filter
460     Filter$="NONE"
470   CASE 1
480     OUTPUT @Afg;"OUTP:FILT:FREQ 250KHZ"   !250 kHz filter
490     OUTPUT @Afg;"OUTP:FILT ON"
500     Filter$="250 kHz"
510   CASE 2
520     OUTPUT @Afg;"OUTP:FILT:FREQ 10MHZ"    !10 MHz filter
530     OUTPUT @Afg;"OUTP:FILT ON"
540     Filter$="10 MHz"
550   END SELECT
560   OUTPUT @Afg;".VOLT "&VAL$(Vout(I))&"VRMS" !Set amplitude
570   PRINT Filter$,Vout(I)
580   WAIT .5
590   !
600   DISP "Record DMM reading, then press 'Continue'"
610   PAUSE
620   DISP
630 NEXT I
640 !
650 OUTPUT @Afg;"*RST;*CLS"                 !Reset AFG
660 END
```

Test 2-5: AC Flatness - 250 kHz Filter

Description

The purpose of this test is to verify that the AFG meets its specifications for AC flatness with the 250 kHz filter enabled.

Equipment Setup

- Connect equipment as shown in Figure 2-6
- Set DMM to ACV, autorange

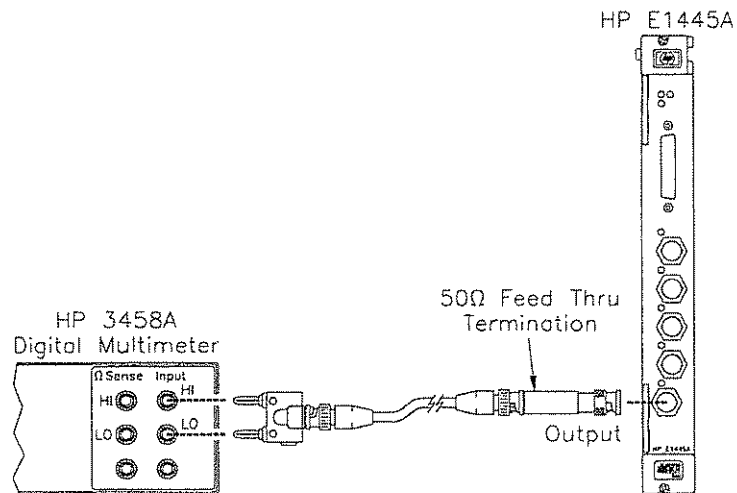

Figure 2-6. Equipment Setup for Test 2-5 and Test 2-6

Test Procedure

1. Reset the AFG:

`*RST;*CLS`

Reset AFG and clear status registers

2. Set up the AFG to output a 24 dBm sinewave with the 250 kHz filter enabled:

`VOLT 24DBM;
:OUTP:LOAD 50
OUTP:FILT:FREQ 250KHZ
OUTP:FILT ON
INIT:IMM`

*Set amplitude
50 ohm load
250 kHz filter
Enable filter
Initiate waveform*

Test 2-5: AC Flatness - 250 kHz Filter (cont'd)

Test Procedure (cont'd)

3. Set the AFG output to the reference frequency (1 kHz):

FREQ 1000 *Set frequency*

4. Measure the amplitude with the DMM and convert the reading to dBm. Note the result for use in step 6:

$$\text{Reference Level (dBm)} = 20 \times \log \left| \text{Reading (volts)} \right| + 13.0103$$

Perform steps 5 - 6 for each frequency listed in Table 2-5:

5. Set the AFG output:

FREQ <frequency> *Set frequency*

where <frequency> is the value specified in Table 2-5.

6. Measure the amplitude with the DMM and convert the reading to dBm. Calculate and record the error relative to the reference level calculated in step 4:

$$\text{Reading (dBm)} = 20 \times \log \left| \text{Reading (volts)} \right| + 13.0103$$

$$\text{Error (dB)} = \text{Reading (dBm)} - \text{ReferenceLevel(dBm)}$$

Test 2-5: AC Flatness - 250 kHz Filter (cont'd)

Test Procedure (cont'd)

Table 2-5. AC Flatness Test Points - 250 kHz Filter

Frequency (Hz)	Test Limits* ±(dB error)
10E3	0.05 dB
20E3	0.05 dB
30E3	0.05 dB
40E3	0.05 dB
50E3	0.05 dB
60E3	0.05 dB
70E3	0.05 dB
80E3	0.05 dB
90E3	0.05 dB
100E3	0.05 dB
110E3	0.10 dB
120E3	0.10 dB
130E3	0.10 dB

Frequency (Hz)	Test Limits* ±(dB error)
140E3	0.10 dB
150E3	0.10 dB
160E3	0.10 dB
170E3	0.10 dB
180E3	0.10 dB
190E3	0.10 dB
200E3	0.10 dB
210E3	0.10 dB
220E3	0.10 dB
230E3	0.10 dB
240E3	0.10 dB
250E3	0.10 dB

* Error relative to 1 kHz

Example Program

See the AC Flatness Adjustment procedure (Chapter 3) for an example program that performs the AC Flatness Test (change line 180 to: Mode\$="M").

Test 2-6: AC Flatness - 10 MHz Filter

Description

The purpose of this test is to verify that the AFG meets its specifications for AC flatness with the 10 MHz filter enabled.

Equipment Setup

- Connect equipment as shown in Figure 2-6
- Set DMM to ACV, autorange

Test Procedure

1. Reset the AFG:

<code>*RST;*CLS</code>	<i>Reset AFG and clear status registers</i>
------------------------	---

2. Set up the AFG to output a 24 dBm sinewave with the 10 MHz filter enabled:

<code>VOLT 24DBM;</code>	<i>Set amplitude</i>
<code>:OUTP:LOAD 50</code>	<i>50 ohm load</i>
<code>OUTP:FILT:FREQ 10MHZ</code>	<i>10 MHz filter</i>
<code>OUTP:FILT ON</code>	<i>Enable filter</i>
<code>INIT:IMM</code>	<i>Initiate waveform</i>

3. Set AFG output to the reference frequency (1 kHz):

<code>FREQ 1000</code>	<i>Set frequency</i>
------------------------	----------------------

4. Measure the amplitude with the DMM, convert the reading to dBm, and note the reading for future reference:

$$\text{Reference Level (dBm)} = 20 \times \log \left| \text{Reading (volts)} \right| + 13.0103$$

5. Set the AFG to the crossover frequency (lowest frequency that the Power Meter can measure):

<code>FREQ 1E5</code>	<i>Set frequency</i>
-----------------------	----------------------

6. Measure the amplitude with the DMM and note the reading for future reference.

Test 2-6: AC Flatness - 10 MHz Filter (cont'd)

Test Procedure (cont'd)

7. Set up the Power Meter:

Units - Watts
Power Range - auto
Reference Oscillator - ON

NOTE

Follow the Power Meter manufacturer's instructions for performing an autocalibration and correcting for the power sensor.

8. Connect the equipment as shown in Figure 2-7:

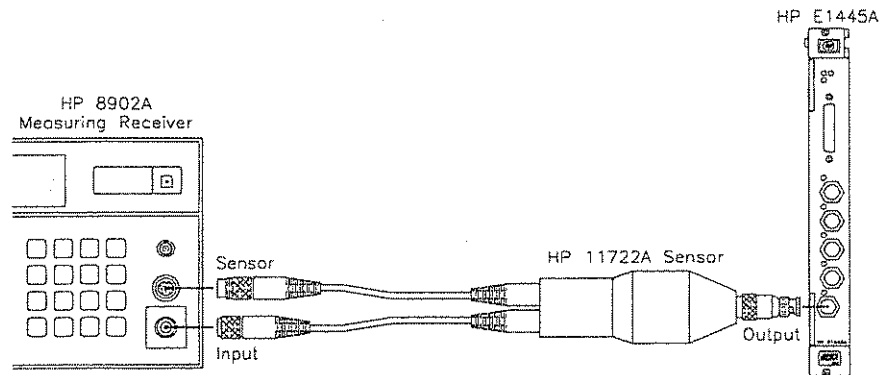

Figure 2-7. Equipment Setup for Test 2-6

9. Set the Power Meter expected frequency to the crossover frequency (100 kHz). Measure the AFG output power and convert the reading to volts:

$$\text{Reading (volts)} = \left(\sqrt{|\text{Reading (watts)}| \times 50} \right)$$

Test 2-6: AC Flatness - 10 MHz Filter (cont'd)

Test Procedure (cont'd)

10. Calculate the correction factor that will be used to reference the Power Meter to the DMM:

$$\text{Correction Factor} = \frac{\text{DMM reading at 100 kHz (step 6)}}{\text{Power Meter reading at 100 kHz (step 9)}}$$

Repeat 11 - 14 for each frequency in Table 2-6:

11. Set the AFG output to the frequency specified in Table 2-6. If the frequency is less than 10.8 MHz, use the following command:

FREQ <frequency>

where <frequency> is the value specified in Table 2-6. If the frequency is 10.8 MHz, use the following register commands to set the output frequency:

```
DIAG:POKE #HE000A1,8,0
DIAG:POKE #HE000A3,8,126
DIAG:POKE #HE000A5,8,95
DIAG:POKE #HE000A7,8,64
DIAG:POKE #HE0008D,8,0
```

12. Set the Power Meter expected frequency to the AFG output frequency.
13. Measure the amplitude with the Power Meter, convert the reading to volts, and multiply by the correction factor.

$$\text{Reading (volts)} = \left(\sqrt{|\text{Reading(watts)}| \times 50} \right)$$

$$\text{Corrected Reading (volts)} = \text{Reading (volts)} \times \text{C.F. (step 10)}$$

14. Convert the reading to dBm. Calculate and record the error relative to the reference level calculated in step 4:

$$\text{Reading (dBm)} = 20 \times \log |\text{CorrectedReading (volts)}| + 13.0103$$

$$\text{Error (dB)} = \text{Reading (dBm)} - \text{ReferenceLevel (dBm)}$$

Test 2-6: AC Flatness - 10 MHz Filter (cont'd)

Test Procedure (cont'd)

Table 2-6. AC Flatness Test Points - 10 MHz Filter

Frequency (Hz)	Test Limits* ±(dB error)	Frequency (Hz)	Test Limits* ±(dB error)
400E3	0.2 dB	6.0E6	0.2 dB
800E3	0.2 dB	6.4E6	0.2 dB
1.2E6	0.2 dB	6.8E6	0.2 dB
1.6E6	0.2 dB	7.2E6	0.2 dB
2.0E6	0.2 dB	7.6E6	0.2 dB
2.4E6	0.2 dB	8.0E6	0.2 dB
2.8E6	0.2 dB	8.4E6	0.2 dB
3.2E6	0.2 dB	8.8E6	0.2 dB
3.6E6	0.2 dB	9.2E6	0.2 dB
4.0E6	0.2 dB	9.6E6	0.2 dB
4.4E6	0.2 dB	10.0E6	0.2 dB
4.8E6	0.2 dB	10.4E6	0.2 dB
5.2E6	0.2 dB	10.8E6	0.2 dB
5.6E6	0.2 dB		

* Error relative to 1 kHz

Example Program

See the AC Flatness Adjustment procedure (Chapter 3) for an example program that performs the AC Flatness Test (change line 180 to: Mode\$="M").

Test 2-7: Frequency Accuracy

Description

The purpose of this test is to verify that the AFG meets its specifications for frequency accuracy.

Equipment Setup

- Connect equipment as shown in Figure 2-8
- Set Counter to: Frequency, 50 Ω input impedance

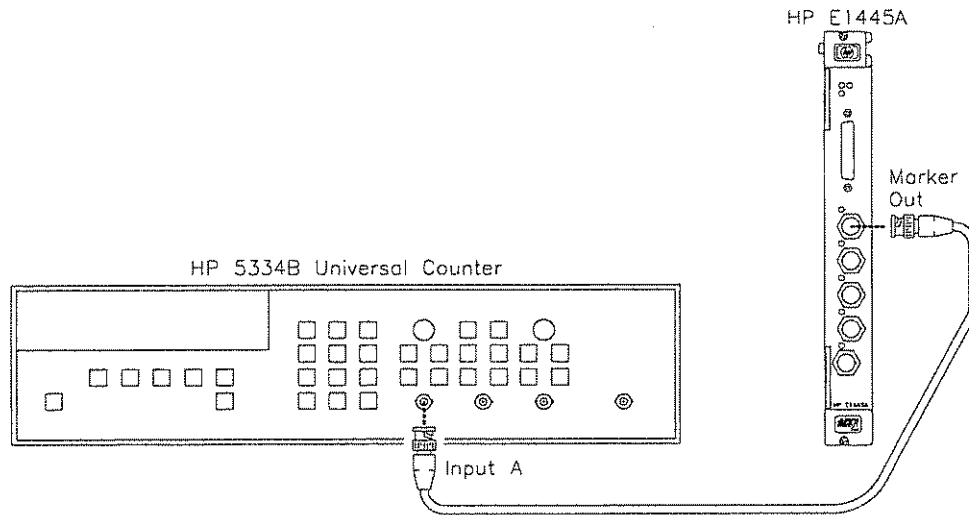

Figure 2-8. Equipment Setup for Test 2-7

Test Procedure

1. Reset the AFG:

`*RST;*CLS`

*Reset AFG and clear
status registers*

Perform steps 2 - 6 for each entry listed in Table 2-7:

2. Abort the waveform if it has been previously initiated:

`ABORT`

Test 2-7: Frequency Accuracy (cont'd)

Test Procedure (cont'd)

3. Set reference oscillator to INT1 or INT2, as specified in Table 2-7:

ROSC:SOUR INT1	<i>Set ref osc to INT1</i>
<i>or</i>	
ROSC:SOUR INT2	<i>Set ref osc to INT2</i>

4. Set marker source to "ROSC" or "TRIG", as specified in Table 2-7:

MARK:FEED "ROSC"	<i>Set marker source to "ROSC"</i>
<i>or</i>	
MARK:FEED "TRIG"	<i>Set marker source to "TRIG"</i>

5. If the marker source is "TRIG", use the following commands to output a squarewave (otherwise, skip this step):

FUNC SQU;	<i>Select squarewave</i>
:FREQ2 <frequency>;	<i>Set AFG frequency</i>
:TRIG:SOUR INT2	<i>Set trig source</i>
INIT:IMM	<i>Initiate</i>

where <frequency> is the value given in the "Squarewave Frequency" column of Table 2-7.

NOTE

If the marker source is "TRIG", the marker output frequency will be four times the frequency of the squarewave, since it takes four points to produce a squarewave. See Table 2-7 for the expected frequencies.

6. Measure frequency with the Counter and record the reading in Table 2-11.

Test 2-7: Frequency Accuracy (cont'd)

Test Procedure (cont'd)

Table 2-7. Frequency Accuracy Test Points

Ref Oscillator Source	Marker Source	Squarewave Frequency (Hz)	Test Limits (Hz)*
INT1	"ROSC"	————	42.94967 E6 ± 0.005%
INT2	"ROSC"	————	40 E6 ± 0.005%
INT2	"TRIG"	5.0 E6	20 E6 ± 0.005%
INT2	"TRIG"	3.333 E3	13.3333 E6 ± 0.005%
INT2	"TRIG"	76.294	305.176 ± 0.005%

*Add aging rate of ±20 ppm/year

Example Program

This program performs the Frequency Accuracy Test.

```

10! RE-STORE "OSC_FREQ"
20 DIM Freq(1:5)
30 !
40 !----- Set up I/O path and reset AFG -----
50 ASSIGN @Afg TO 70910
60 OUTPUT @Afg;"*RST;*CLS"           !Reset AFG
70 !
80 !----- Initialize variables -----
90 DATA 42.94967E6,40E6,20E6,13.3333E6,305.176
100 READ Freq(*)
110 !
120 !----- Set up Counter -----
130 CLEAR SCREEN
140 PRINT "Set up Counter:"
150 PRINT
160 PRINT "  Function -- Frequency"
170 PRINT "  Input Impedance -- 50 ohms"
180 PRINT
190 PRINT "Connect the Counter to 'Marker Out' on the HP E1445A."
200 PRINT
210 DISP "Press 'Continue'"
220 PAUSE
230 CLEAR SCREEN
240 !

```

(Continued on next page)

Test 2-7: Frequency Accuracy (cont'd)

Example Program (cont'd)

```
250 |----- Set up AFG -----
260 OUTPUT @Afg;"*RST"                !Reset AFG
270 WAIT .5
280 !
290 |----- Perform test -----
300 FOR I=1 TO 5
310   PRINT "Expected reading =";Freq(I)
320   PRINT
330   IF I=1 THEN
340     OUTPUT @Afg;"ROSC:SOUR INT1"    !ROSC = INT1
350     OUTPUT @Afg;"MARK:FEED ""ROSC"" !Marker source = ROSC
360   ELSE
370     OUTPUT @Afg;"ABORT"            !Abort waveform
380     OUTPUT @Afg;"ROSC:SOUR INT2"    !ROSC = INT2
390     IF Freq(I)=4.0E+7 THEN
400       OUTPUT @Afg;"MARK:FEED ""ROSC"" !Marker source = ROSC
410     ELSE
420       OUTPUT @Afg;":FUNC SQU;";     !Squarewave
430       !
440       !Square wave freq is 1/4 of marker freq
450       OUTPUT @Afg;":FREQ2 "&VAL$(Freq(I)/4)&";";
460       OUTPUT @Afg;":TRIG:STAR:SOUR INT2"!TRIG source = INT2
470       OUTPUT @Afg;"MARK:FEED ""TRIG"" !Marker source = TRIG
480     END IF
490   END IF
500   !
510   OUTPUT @Afg;"INIT:IMM"           !Initiate
520   WAIT 1
530   !
540   DISP "Record the Counter reading, then press 'Continue'"
550   PAUSE
560   DISP
570 NEXT I
580 !
590 OUTPUT @Afg;"*RST;*CLS"           !Reset AFG
600 END
```

Test 2-8: Duty Cycle

Description

The purpose of this test is to verify that the AFG meets its specifications for square wave duty cycle. Duty cycle is determined by measuring positive pulse width.

Equipment Setup

- Connect equipment as shown in Figure 2-9
- Set Counter to: Pulse Width, DC coupling, 50Ω input impedance

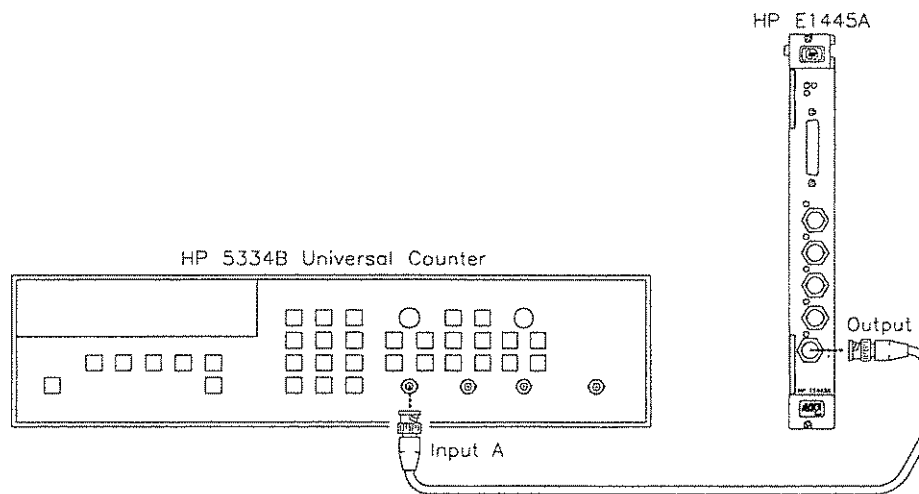

Figure 2-9. Equipment Setup for Test 2-8

Test Procedure

1. Reset the AFG:

*RST;*CLS

*Reset AFG and clear
status registers*

2. Set the AFG to output a square wave:

FUNC SQU;
:VOLT MAX

*Select squarewave
Set to max amplitude*

Perform steps 3 - 7 for each frequency listed in Table 2-8:

3. Abort the waveform if it has been previously initiated:

ABORT

Test 2-8: Duty Cycle (cont'd)

Test Procedure (cont'd)

4. Set the AFG frequency range as specified in Table 2-8:

FREQ:RANG MAX *Enable doubling*
or
FREQ:RANG MIN *Disable doubling*

5. Set AFG output frequency:

FREQ <frequency> *Set frequency*

where <frequency> is the value specified in Table 2-8.

6. Initiate the waveform:

INIT:IMM

7. Measure positive pulse width (average at least 10 periods) with the Counter and record the reading in Table 2-11.

NOTE

If a percentage result is desired, measure the period (average at least 10 periods). $Duty\ Cycle\ (\%) = 100 \times (Positive\ Pulse\ Width/Period)$

Table 2-8. Duty Cycle Test Points

Frequency (Hz)	Frequency Range	Test Limits (sec)
1.0 E3	MIN	5.0E-3 ± 1.0E-6
2.0 E3	MAX	2.5E-4 ± 3.0E-5
2.5 E5	MIN	2.0E-7 ± 3.4E-9
5.0 E5	MAX	1.0E-7 ± 1.5E-8

Test 2-8: Duty Cycle (cont'd)

Example Program

This program performs the Duty Cycle Test.

```
10! RE-STORE "DUTY_CYCLE"
20 DIM Freq(1:4),Range$(1:4)[10]
30 !
40 !----- Set up I/O path and reset AFG -----
50 ASSIGN @Afg TO 70910
60 OUTPUT @Afg;"*RST;*CLS"                !Reset AFG
70 !
80 !----- Initialize variables -----
90 DATA 1E3,2E3,2.5E5,5E5
100 READ Freq(*)
110 !
120 DATA MIN,MAX,MIN,MAX                  !'MAX' enables doubling
130 READ Range$(*)                        !'MIN' disables doubling
140 !
150 !----- Set up Counter -----
160 CLEAR SCREEN
170 PRINT "Set up Counter:"
180 PRINT "  Function -- Pulse Width"
190 PRINT "  Coupling -- DC"
210 PRINT "  Input Impedance -- 50 ohms"
220 PRINT
230 PRINT "Connect Counter to AFG Output."
240 DISP "Press 'Continue' when ready"
250 PAUSE
260 CLEAR SCREEN
270 !
280 !----- Set up AFG -----
290 OUTPUT @Afg;"*RST"                    !Reset AFG
300 OUTPUT @Afg;"FUNC SQU;";              !Squarewave
310 OUTPUT @Afg;":VOLT MAX"                !MAX output
320 !
330 !----- Perform test -----
340 FOR I=1 TO 4
350   OUTPUT @Afg;"ABORT"                  !Abort waveform
360   OUTPUT @Afg;"FREQ:RANG "&Range$(I)&";"; !Freq doubling on/off
370   OUTPUT @Afg;":FREQ "&VAL$(Freq(I))    !Set frequency
380   OUTPUT @Afg;"INIT:IMM"                !Initiate
390   WAIT 1
400   !
```

(Continued on next page)

Test 2-8: Duty Cycle (cont'd)

Example Program (cont'd)

```
410 !Take readings here
420 PRINT "Output Frequency =";Freq(I);" Hz"
430 PRINT
440 PRINT "Read positive pulse width (average at least 10 periods)."
```

Test 2-9: Total Harmonic Distortion

Description

The purpose of this test is to verify that the AFG meets its specifications for sine wave total harmonic distortion (THD).

Equipment Setup

- Connect equipment as shown in Figure 2-10
- Set Spectrum Analyzer to:

Ref Level = 25 dBm

Freq Span = 1 kHz

Resolution BW = 30 Hz

Video BW = 30 Hz

NOTE

These are recommended settings only. Adjust your Spectrum Analyzer as necessary.

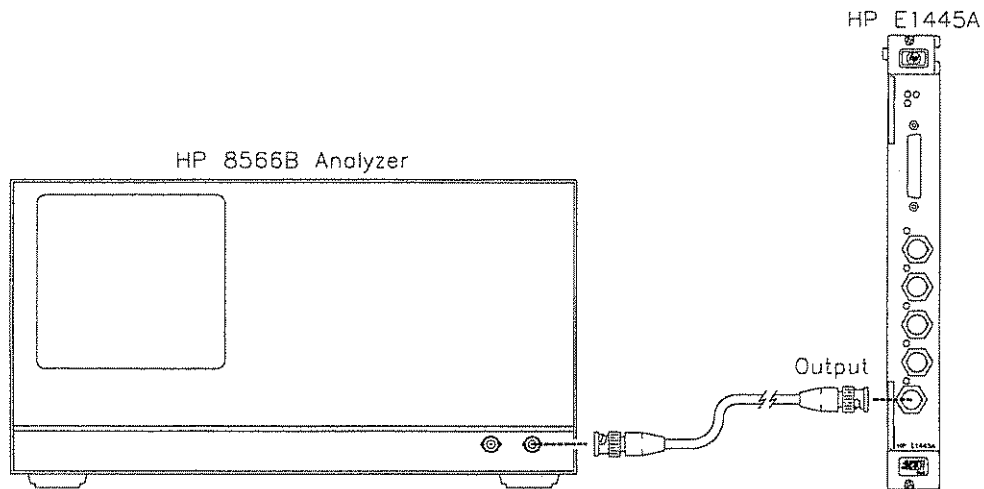

Figure 2-10. Equipment Setup for Test 2-9 and Test 2-10

Test 2-9: Total Harmonic Distortion (cont'd)

Test Procedure

1. Reset the AFG:

*RST;*CLS

*Reset AFG and clear
status registers*

2. Set the AFG to output a sinewave with the 10 MHz filter enabled:

VOLT 24DBM
OUTP:FILT:FREQ 10 MHZ
OUTP:FILT ON
INIT:IMM

*Set AFG amplitude
Set filter to 10 MHz
Enable filter
Initiate waveform*

Perform steps 3 - 6 for each frequency listed in Table 2-9:

3. Set AFG output frequency:

FREQ <frequency>

Set frequency

where <frequency> is the value specified in Table 2-9.

4. Set the Spectrum Analyzer center frequency to the output frequency of the AFG. Measure the peak amplitude of the fundamental in dBm. Note the result for use in step 6.
5. Set the Spectrum Analyzer center frequency to the second harmonic ($2 \times \text{fundamental frequency}$). Measure the peak amplitude of the second harmonic in dBm.
6. Repeat step 5 for third through ninth harmonics. Calculate total harmonic distortion as shown below:

$$\text{thd (dBc)} = 20 \cdot \log \left(\sqrt{\text{result}_2^2 + \text{result}_3^2 + \dots + \text{result}_9^2} \right)$$

where

$$\text{result}_n (\text{volts}) = 10^{[(n^{\text{th}} \text{ Harmonic(dBm)} - \text{Fundamental (dBm)})/20]}$$

Test 2-9: Total Harmonic Distortion (cont'd)

Test Procedure (cont'd)

Table 2-9. THD Test Points

Frequency (Hz)	Test Limits* (dBc)
100 E3	-60
250 E3	-60
1 E6	-48
4 E6	-36
10 E6	-36

* Through 9th harmonic

Example Program

This program performs the Total Harmonic Distortion Test.

```
10! RE-STORE "SINE_THD"
20 DIM Freq(1:5)
30 !
40 !----- Set up I/O path and reset AFG -----
50 ASSIGN @Afg TO 70910 !AFG I/O path
60 OUTPUT @Afg;"*RST;*CLS" !Reset AFG
70 !
80 !----- Initialize variables -----
90 Dbm_out$="24DBM" !AFG output
100 !
110 DATA 100E3,250E3,1E6,4E6,10E6 !Read in freqs
120 READ Freq(*)
130 !
140 !----- Set up Spec Analyzer -----
150 CLEAR SCREEN
160 PRINT "Set up Spectrum Analyzer:"
170 PRINT
180 PRINT " Ref Level = 25 dBm"
190 PRINT " Span = 1 kHz"
200 PRINT " Resolution BW = 30 Hz"
210 PRINT " Video BW = 30 Hz"
220 PRINT
```

(Continued on next page)

Test 2-9: Total Harmonic Distortion (cont'd)

Example Program (cont'd)

```
230 PRINT "Connect Spectrum Analyzer to AFG Output."
240 DISP "Press 'Continue' when ready"
250 PAUSE
260 !
270 !----- Set up AFG -----
280 OUTPUT @Afg;"*RST" !Reset AFG
290 WAIT 1
300 OUTPUT @Afg;"VOLT "&Dbm_out$ !Set AFG output
310 OUTPUT @Afg;"OUTP:FILT:FREQ 10MHZ" !Enable 10MHz filter
320 OUTPUT @Afg;"OUTP:FILT ON"
330 OUTPUT @Afg;"INIT:IMM" !Initiate
340 !
350 !----- Perform test -----
360 FOR I=1 TO 5
370 OUTPUT @Afg;"FREQ "&VAL$(Freq(I)) !Set frequency
380 !
390 CALL Meas_thd(Freq(I),Thd) !Measure THD
400 PRINT "Fundamental Frequency =";Freq(I)
410 PRINT "THD =";DROUND(Thd,4);"dBc"
420 PRINT
430 DISP "Press 'Continue' when ready"
440 PAUSE
450 DISP
460 NEXT I
470 !
480 OUTPUT @Afg;"*RST;*CLS" !Reset AFG
490 END
500 !
510 !
520 !----- Measurement subprogram -----
530 SUB Meas_thd(Frequency,Thd)
540 INTEGER Harmonic
550 CLEAR SCREEN
560 Harmonic=1
570 !
580 GOSUB Meas_fund !Get fundamental amplitude
590 !
```

(Continued on next page)

Test 2-9: Total Harmonic Distortion (cont'd)

Example Program (cont'd)

```
600 !Measure harmonics 2-9
610 Sum_amp_sqr=0
620 FOR Harmonic=2 TO 9
630     GOSUB Meas_amp
640     Sum_amp_sqr=Sum_amp_sqr+10^(Result/10)    !Sum of squared voltages
650 NEXT Harmonic
660 !
670 Thd=20*LGT(SQRT(Sum_amp_sqr))                !Calculate THD In dBc
680 SUBEXIT
690 !
700 Meas_fund: !
710 PRINT "FUNDAMENTAL"
720 PRINT "Set Spectrum Analyzer Center Freq to: "&VAL$(Frequency)&" Hz."
730 PRINT "Measure amplitude at the center frequency."
740 PRINT
750 INPUT "Enter amplitude (in dBm):",Baseline
760 RETURN
770 !
780 Meas_amp: !
790 PRINT "HARMONIC =";Harmonic
800 PRINT "Set Spectrum Analyzer Center Freq to: "&VAL$(Frequency*Harmonic)&" Hz."
810 PRINT "Measure amplitude at the center frequency."
820 PRINT
830 INPUT "Enter amplitude (in dBm):",Reading
840 Result=Reading-Baseline
850 RETURN
860 SUBEND
```

Test 2-10: Spurious/Non-Harmonic Distortion

Description

The purpose of this test is to verify that the AFG meets its specifications for non-harmonic and spurious distortion.

Equipment Setup

- Connect equipment as shown in Figure 2-9
- Set Spectrum Analyzer to :

Ref Level = -5 dBm
Resolution BW = 3 kHz
Video BW = 3 kHz

NOTE

These are recommended settings only. Adjust your Spectrum Analyzer as necessary.

Test Procedure

1. Reset the AFG:

*RST;*CLS

*Reset AFG and clear
status registers*

2. Set the AFG to output a -5 dBm, 10 MHz sinewave with the 10 MHz filter enabled:

FREQ 1.0E7;
:VOLT -5DBM
OUTP:FILT:FREQ 10 MHZ
OUTP:FILT ON
INIT:IMM

*Set AFG frequency
Set AFG amplitude
Set filter to 10 MHz
Enable filter
Initiate waveform*

Test 2-10: Spurious/Non-Harmonic Distortion (cont'd)

Test Procedure (cont'd)

Perform steps 3 and 4 for each frequency range listed in Table 2-10:

3. Set the Spectrum Analyzer start frequency and stop frequency to the values listed in Table 2-10.
4. Measure the amplitude (in dBm) of the highest peak. Subtract the amplitude of the fundamental (-5dBm) from the reading and record the result in Table 2-11:

$$\text{result (dBc)} = \text{reading(dBm)} - (-5 \text{ dBm})$$

Table 2-10. Spurious/Non-Harmonic Test Points

Start Frequency (Hz)	Stop Frequency (Hz)	Test Limits (dBc)
100 E3	9.5 E6	-45
10.5 E6	19 E6	-45
21 E6	29 E6	-45
31 E6	39 E6	-45
41 E6	49 E6	-45
51 E6	75 E6	-45
75 E6	100 E6	-45
100 E6	125 E6	-45
125 E6	150 E6	-45

Test 2-10: Spurious/Non-Harmonic Distortion (cont'd)

Example Program

This program performs the Spurious/Non-harmonic Test.

```
10 ! RE-STORE "NON_HARM"
20 DIM Start_freq(1:9),Stop_freq(1:9),Max_ampl(1:9)
30 !
40 !----- Set up I/O path and reset AFG -----
50 ASSIGN @Afg TO 70910 !AFG I/O path
60 OUTPUT @Afg;"*RST;*CLS" !Reset AFG
70 !
80 !----- Initialize variables -----
90 Freq_out=1.0E+7 !Freq = 10 MHz
100 Dbm_out$="-5DBM" !Amplitude = -5dBm
110 !
120 DATA 100E3,10.5E6,21E6,31E6,41E6,51E6,75E6,100E6,125E6
130 READ Start_freq(*) !Read start freqs
140 !
150 DATA 9.5E6,19E6,29E6,39E6,49E6,75E6,100E6,125E6,150E6
160 READ Stop_freq(*) !Read stop freqs
170 !
180 !----- Set up Spec Analyzer -----
190 CLEAR SCREEN
200 PRINT "Set up Spectrum Analyzer:"
210 PRINT
220 PRINT " Ref Level = -5dBm"
230 PRINT " Resolution BW = 3 kHz"
240 PRINT " Video BW = 3 kHz"
250 PRINT
260 PRINT "Connect Spectrum Analyzer to AFG Output."
270 DISP "Press 'Continue' when ready"
280 PAUSE
290 CLEAR SCREEN
300 !
310 !----- Set up AFG -----
320 OUTPUT @Afg;"*RST" !Reset AFG
330 WAIT 1
340 OUTPUT @Afg;"FREQ "&VAL$(Freq_out)&";" !Set frequency
350 OUTPUT @Afg;"VOLT "&Dbm_out$ !Set amplitude
360 OUTPUT @Afg;"OUTP:FILT:FREQ 10MHZ" !Enable 10MHz filter
370 OUTPUT @Afg;"OUTP:FILT ON"
380 OUTPUT @Afg;"INIT:IMM" !Initiate
390 !
```

(Continued on next page)

Test 2-10: Spurious/Non-Harmonic Distortion (cont'd)

Example Program (cont'd)

```
400 !----- Perform test -----
410 FOR I=1 TO 9
420   CLEAR SCREEN
430   PRINT "Set Spectrum Analyzer Start Freq to: ";Start_freq(I);"Hz"
440   PRINT "Set Spectrum Analyzer Stop Freq to: ";Stop_freq(I);"Hz"
450   PRINT "Measure the amplitude of the highest peak."
460   PRINT
470   INPUT "Enter amplitude (in dBm):",Peak_ampl
480   PRINT "Result =";VAL(Dbm_out$)-Peak_ampl;"dBc" !Calculate result in dBc
490   DISP "Press 'Continue' when ready"
500   PAUSE
510   DISP
520 NEXT I
530 !
540 OUTPUT @Afg;"*RST;*CLS"           !Reset AFG
550 END
```

Performance Test Record

Table 2-11, *Performance Test Record for the HP E1445A AFG*, is a form you can copy and use to record performance verification test results for the AFG. Table 2-11 shows AFG accuracy, measurement uncertainty, and test accuracy ratio (TAR) values.

AFG Test Limits

Test limits are defined using the specifications in Appendix A of the *HP E1445A User's Manual*. The specifications for Total Harmonic Distortion and Spurious/Non-harmonic Distortion are single-sided (i.e., there is an upper limit but no lower limit). In the Performance Test Record, the Minimum column will be blank.

Measurement Uncertainty

For the performance verification tests in this manual, the measurement uncertainties are based on the accuracy specifications for the following test equipment:

Performance Test	Test Equipment
1. DC Zeros	HP 3458A
2. DC Accuracy	HP 3458A
3. DC Offset	HP 3458A
4. AC Accuracy	HP 3458A
5. AC Flatness (250 kHz filter)	HP 3458A
6. AC Flatness (10 MHz filter)*	HP 3458A HP 8902A
7. Frequency Accuracy	HP 5334B
8. Duty Cycle	HP 5334B
9. Total Harmonic Distortion	HP 8566B
10. Spurious/Non-harmonic Distortion	HP 8566B

* Includes following uncertainties: HP 8902A Range linearity, HP 11722A Power Sensor Cal Factor uncertainty, HP 3458A accuracy at 100 kHz.

Test Accuracy Ratio (TAR)

Test Accuracy Ratio (TAR) for the HP E1445A is defined as: AFG Accuracy/Measurement Uncertainty, i.e.,

$$\text{TAR} = \frac{\text{Maximum- Expected Reading}}{\text{Measurement Uncertainty}}$$

For single-sided measurements, Test Accuracy Ratio is not defined, so 'NA' (Not Applicable) will appear in the TAR column. For TARs that exceed 10:1, the entry is '>10:1'.

Table 2-11. Performance Test Record for the HP E1445A (Page 1 of 7)

Test Facility:	
Name _____	Report No. _____
Address _____	Date _____
City/State _____	Customer _____
Phone _____	Tested by _____
Model _____	Ambient temperature _____ °C
Serial No. _____	Relative humidity _____ %
Options _____	Line frequency _____ Hz (nominal)
Firmware Rev. _____	
Special Notes:	

Table 2-11. Performance Test Record for the HP E1445A (Page 2 of 7)

Model _____ Report No. _____ Date _____

Test Equipment Used: Description	Model No.	Trace No.	Cal Due Date
1. _____	_____	_____	_____
2. _____	_____	_____	_____
3. _____	_____	_____	_____
4. _____	_____	_____	_____
5. _____	_____	_____	_____
6. _____	_____	_____	_____
7. _____	_____	_____	_____
8. _____	_____	_____	_____
9. _____	_____	_____	_____
10. _____	_____	_____	_____
11. _____	_____	_____	_____
12. _____	_____	_____	_____
13. _____	_____	_____	_____
14. _____	_____	_____	_____
15. _____	_____	_____	_____
16. _____	_____	_____	_____
17. _____	_____	_____	_____
18. _____	_____	_____	_____
19. _____	_____	_____	_____
20. _____	_____	_____	_____

Table 2-11. Performance Test Record for the HP E1445A (Page 3 of 7)

Model _____ Report No. _____ Date _____

Test Description*	Minimum	Measured Reading	Maximum	Meas Uncert	TAR
Test 2-1. DC Zeros Test (Values in Vdc)					
No Filter:					
10.2375V (0 dB atten)	-0.022	_____	0.022	1E-6	>10:1
9.1347V (.99 dB atten)	-0.022	_____	0.022	1E-6	>10:1
9.1241V (1 dB atten)	-0.022	_____	0.022	1E-6	>10:1
8.1319V (2 dB atten)	-0.022	_____	0.022	1E-6	>10:1
6.4594V (4 dB atten)	-0.022	_____	0.022	1E-6	>10:1
4.0756V (8 dB atten)	-0.022	_____	0.022	1E-6	>10:1
2.2918V (13 dB atten)	-0.022	_____	0.022	1E-6	>10:1
2.0426V (14 dB atten)	-0.0044	_____	0.0044	1E-6	>10:1
0.3238V (30 dB atten)	-0.0044	_____	0.0044	1E-6	>10:1
250 kHz Filter:					
10.2375V (0 dB atten)	-0.022	_____	0.022	1E-6	>10:1
9.1347V (.99 dB atten)	-0.022	_____	0.022	1E-6	>10:1
9.1241V (1 dB atten)	-0.022	_____	0.022	1E-6	>10:1
8.1319V (2 dB atten)	-0.022	_____	0.022	1E-6	>10:1
6.4594V (4 dB atten)	-0.022	_____	0.022	1E-6	>10:1
4.0756V (8 dB atten)	-0.022	_____	0.022	1E-6	>10:1
2.2918V (13 dB atten)	-0.022	_____	0.022	1E-6	>10:1
2.0426V (14 dB atten)	-0.0044	_____	0.0044	1E-6	>10:1
0.3238V (30 dB atten)	-0.0044	_____	0.0044	1E-6	>10:1
10 MHz Filter:					
10.2375V (0 dB atten)	-0.022	_____	0.022	1E-6	>10:1
9.1347V (.99 dB atten)	-0.022	_____	0.022	1E-6	>10:1
9.1241V (1 dB atten)	-0.022	_____	0.022	1E-6	>10:1
8.1319V (2 dB atten)	-0.022	_____	0.022	1E-6	>10:1
6.4594V (4 dB atten)	-0.022	_____	0.022	1E-6	>10:1
4.0756V (8 dB atten)	-0.022	_____	0.022	1E-6	>10:1
2.2918V (13 dB atten)	-0.022	_____	0.022	1E-6	>10:1
2.0426V (14 dB atten)	-0.0044	_____	0.0044	1E-6	>10:1
0.3238V (30 dB atten)	-0.0044	_____	0.0044	1E-6	>10:1

* Since the arbitrary waveform consists of zeros, the expected reading is 0 V, regardless of the amplitude setting. The amplitude is changed in order to turn the various attenuators on and off.

Table 2-11. Performance Test Record for the HP E1445A (Page 4 of 7)

Model _____ Report No. _____ Date _____

Test Description	Minimum	Measured Reading	Maximum	Meas Uncert	TAR
Test 2-2. DC Accuracy Test (Values in Vdc)					
No Filter:					
10.2375V	10.1863	_____	10.2887	4.9E-5	>10:1
5.0V	4.9645	_____	5.0355	2.5E-5	>10:1
0.0V	-0.0205	_____	0.0205	1.0E-6	>10:1
-5.0V	-5.0355	_____	-4.9645	2.5E-5	>10:1
-10.24V	-10.2912	_____	-10.1888	4.9E-5	>10:1
250 kHz Filter:					
10.2375V	10.1863	_____	10.2887	4.4E-5	>10:1
-10.24V	-10.2912	_____	-10.1888	2.3E-5	>10:1
10 MHz Filter:					
10.2375V	10.1863	_____	10.2887	4.4E-5	>10:1
-10.24V	-10.2912	_____	-10.1888	2.3E-5	>10:1
Test 2-3. DC Offset Test (Values in Vdc)					
13 dB attenuation:					
9.755V	9.6355	_____	9.8746	4.7E-5	>10:1
4.0V	3.9380	_____	4.0620	2.04E-5	>10:1
-4.0V	-4.0620	_____	-3.9380	2.04E-5	>10:1
-9.755V	-9.8746	_____	-9.6355	4.7E-5	>10:1
28 dB attenuation:					
2.0V	1.9756	_____	2.0244	1.12E-5	>10:1
-2.0V	-2.0244	_____	-1.9756	1.12E-5	>10:1
Test 2-4. AC Accuracy Test (Values in Vac)					
No Filter:					
7.239V (0 dB atten)	7.1561	_____	7.3228	2.46E-3	>10:1
6.45V (1 dB atten)	6.3396	_____	6.5624	2.3E-3	>10:1
5.75V (2 dB atten)	5.6516	_____	5.8502	2.16E-3	>10:1
4.566V (4 dB atten)	4.4878	_____	4.6455	1.9E-3	>10:1
2.881V (8 dB atten)	2.8317	_____	2.9312	1.58E-3	>10:1
1.440V (14 dB atten)	1.4153	_____	1.4651	1.29E-3	>10:1
0.229V (30 dB atten)	0.2251	_____	0.2330	1.46E-4	>10:1
250 kHz Filter:					
7.239V (0 dB atten)	7.1561	_____	7.3228	2.46E-3	>10:1
10 MHz Filter:					
7.239V (0 dB atten)	7.1561	_____	7.3228	2.46E-3	>10:1

Table 2-11. Performance Test Record for the HP E1445A (Page 5 of 7)

Model _____ Report No. _____ Date _____

Test Description	Minimum	Measured Reading	Maximum	Meas Uncert	TAR
Test 2-5. AC FlatnessTest - 250 kHz Filter (Values in dB error, relative to 1 kHz)					
Amplitude at 24 dBm:					
10 kHz	-0.05	_____	0.05	.002 dB	>10:1
20 kHz	-0.05	_____	0.05	.002 dB	>10:1
30 kHz	-0.05	_____	0.05	.0034 dB	>10:1
40 kHz	-0.05	_____	0.05	.0034 dB	>10:1
50 kHz	-0.05	_____	0.05	.0034 dB	>10:1
60 kHz	-0.05	_____	0.05	.0077 dB	7:1
70 kHz	-0.05	_____	0.05	.0077 dB	7:1
80 kHz	-0.05	_____	0.05	.0077 dB	7:1
90 kHz	-0.05	_____	0.05	.0077 dB	7:1
100 kHz	-0.05	_____	0.05	.0077 dB	7:1
110 kHz	-0.10	_____	0.10	.028 dB	4:1
120 kHz	-0.10	_____	0.10	.028 dB	4:1
130 kHz	-0.10	_____	0.10	.028 dB	4:1
140 kHz	-0.10	_____	0.10	.028 dB	4:1
150 kHz	-0.10	_____	0.10	.028 dB	4:1
160 kHz	-0.10	_____	0.10	.028 dB	4:1
170 kHz	-0.10	_____	0.10	.028 dB	4:1
180 kHz	-0.10	_____	0.10	.028 dB	4:1
190 kHz	-0.10	_____	0.10	.028 dB	4:1
200 kHz	-0.10	_____	0.10	.028 dB	4:1
210 kHz	-0.10	_____	0.10	.028 dB	4:1
220 kHz	-0.10	_____	0.10	.028 dB	4:1
230 kHz	-0.10	_____	0.10	.028 dB	4:1
240 kHz	-0.10	_____	0.10	.028 dB	4:1
250 kHz	-0.10	_____	0.10	.028 dB	4:1

Table 2-11. Performance Test Record for the HP E1445A (Page 6 of 7)

Model _____ Report No. _____ Date _____

Test Description	Minimum	Measured Reading	Maximum	Meas Uncert	TAR
Test 2-6. AC Flatness Test - 10 MHz Filter (Values in dB error, relative to 1 kHz)					
Amplitude at 24 dBm:					
400 kHz	-0.2	_____	0.2	0.0478 dB	4:1
800 kHz	-0.2	_____	0.2	0.0506 dB	4:1
1.2 MHz	-0.2	_____	0.2	0.0506 dB	4:1
1.6 MHz	-0.2	_____	0.2	0.0506 dB	4:1
2.0 MHz	-0.2	_____	0.2	0.0506 dB	4:1
2.4 MHz	-0.2	_____	0.2	0.0506 dB	4:1
2.8 MHz	-0.2	_____	0.2	0.0506 dB	4:1
3.2 MHz	-0.2	_____	0.2	0.0506 dB	4:1
3.6 MHz	-0.2	_____	0.2	0.0506 dB	4:1
4.0 MHz	-0.2	_____	0.2	0.0506 dB	4:1
4.4 MHz	-0.2	_____	0.2	0.0506 dB	4:1
4.8 MHz	-0.2	_____	0.2	0.0506 dB	4:1
5.2 MHz	-0.2	_____	0.2	0.0506 dB	4:1
5.6 MHz	-0.2	_____	0.2	0.0506 dB	4:1
6.0 MHz	-0.2	_____	0.2	0.0506 dB	4:1
6.4 MHz	-0.2	_____	0.2	0.0506 dB	4:1
6.8 MHz	-0.2	_____	0.2	0.0536 dB	4:1
7.2 MHz	-0.2	_____	0.2	0.0536 dB	4:1
7.6 MHz	-0.2	_____	0.2	0.0536 dB	4:1
8.0 MHz	-0.2	_____	0.2	0.0536 dB	4:1
8.4 MHz	-0.2	_____	0.2	0.0536 dB	4:1
8.8 MHz	-0.2	_____	0.2	0.0536 dB	4:1
9.2 MHz	-0.2	_____	0.2	0.0536 dB	4:1
9.6 MHz	-0.2	_____	0.2	0.0536 dB	4:1
10.0 MHz	-0.2	_____	0.2	0.0536 dB	4:1
10.4 MHz	-0.2	_____	0.2	0.0536 dB	4:1
10.8 MHz	-0.2	_____	0.2	0.0536 dB	4:1

Table 2-11. Performance Test Record for the HP E1445A (Page 7 of 7)

Model _____ Report No. _____ Date _____

Test Description	Minimum	Measured Reading	Maximum	Meas Uncert	TAR
Test 2-7. Frequency Accuracy Test (Values in Hz) *					
Marker source is "ROSC":					
42.9497 MHz	42.9467E6	_____	42.9527E6	8.0	>10:1
40.0 MHz	39.9972E6	_____	40.0028E6	8.0	>10:1
Marker source is "TRIG":					
20.0 MHz	19.9986E6	_____	20.0014E6	5.0	>10:1
13.3333 MHz	13.3324E6	_____	13.3342E6	3.8	>10:1
305.176 Hz	305.1546	_____	305.1974	0.00305	7:1
Test 2-8. Duty Cycle Test (Values in nsec)					
1 kHz, .5 msec pulse width	4.99E-4	_____	5.01E-4	2.1E-9	>10:1
2 kHz, .25 msec pulse width	2.2E-4	_____	2.8E-4	1.8E-9	>10:1
250 kHz, 2 µsec pulse width	1.993E-6	_____	2.007E-6	1.2E-9	6:1
500 kHz, 1 µsec pulse width	8.77E-7	_____	1.123E-6	1.2E-9	>10:1
Test 2-9. Total Harmonic Distortion Test (Values in dBc) **					
24 dBm sinewave:					
100 kHz		_____	-60 dBc	1.23 dB	NA
250 kHz		_____	-60 dBc	1.23 dB	NA
1 MHz		_____	-48 dBc	1.23 dB	NA
4 MHz		_____	-36 dBc	1.23 dB	NA
10 MHz		_____	-36 dBc	1.23 dB	NA
Test 2-10. Spurious/Non-harmonic Distortion Test (Values in dBc) **					
10 MHz, -5 dBm sinewave:					
100 kHz - 9.5 MHz		_____	-45 dBc	1.23 dB	NA
10.5 MHz - 19 MHz		_____	-45 dBc	1.23 dB	NA
21 MHz - 29 MHz		_____	-45 dBc	1.23 dB	NA
31 MHz - 39 MHz		_____	-45 dBc	1.23 dB	NA
41 MHz - 49 MHz		_____	-45 dBc	1.23 dB	NA
51 MHz - 75 MHz		_____	-45 dBc	1.23 dB	NA
75 MHz - 100 MHz		_____	-45 dBc	1.23 dB	NA
100 MHz - 125 MHz		_____	-45 dBc	1.23 dB	NA
125 MHz - 150 MHz		_____	-45 dBc	1.23 dB	NA

* Test limits assume 1 year of aging @ ±20 ppm/year

** Single-sided test -- Minimum is not applicable



Chapter 3

Adjustments

Introduction

The procedures in this chapter show how to perform the following electronic adjustments for the AFG:

- DC Accuracy
- AC Flatness (250 kHz and 10MHz filters)
- Skew

NOTE

The DC adjustment procedure should be performed before the AC flatness adjustment procedures.

Required Equipment

See Table 1-1 for test equipment required for the procedures described in this chapter.

Recommended Environment

Before performing these procedures, allow the AFG to warm up for at least one hour. The temperature should be within $\pm 5^{\circ}\text{C}$ of T_{cal} (the temperature of the most recent calibration), and between 18°C and 28°C .

Calibration Commands

This section provides a brief description of commands that relate to calibration of the AFG. More information on these commands can be found in the Command Reference section of the *HP E1445A User's Manual*.

- **CALibration:COUNT?** returns the number of times that the AFG has been calibrated. Each adjustment procedure in this chapter increments the calibration number by 1.
- **CALibration:SECure:CODE <code>** sets the code that disables calibration security. The code is set at the factory to "E1445A". Calibration security must be disabled before changing the code.

Calibration Commands (cont'd)

- **CALibration:SECure[:STATe] <mode>[,<code>]** enables (<mode> = ON) or disables (<mode> = OFF) calibration security. The security code is required for CAL:SEC:STAT OFF, but the code is optional for CAL:SEC:STAT ON. The *RST command also enables calibration security.
- **CALibration[:DC]:BEGin** starts the DC calibration sequence and sets up the AFG for the first calibration point.
- **CALibration[:DC]:POINT? <value>** sends a value to the AFG so that the appropriate calibration constant(s) can be calculated. The AFG returns two numbers: (1) the current calibration point, and (2) an error code (see Appendix B of the *HP E1445A User's Manual* for more information about AFG errors). Any non-zero error code indicates a failure. This command also sets up the AFG for the next calibration point.
- **CALibration:DATA[:DC] <block>** transfers the DC calibration constants to the AFG. The DC calibration procedure described in this chapter should be used in place of this command. The query form returns the current DC constants in IEEE-488.2 definite block data format.
- **CALibration:DATA:AC[1] <block>** transfers the AC calibration constants that are used with the 250 kHz filter. The query form returns the current constants in IEEE-488.2 definite block data format. See the AC Flatness Adjustment procedures for more information on the use of this command.
- **CALibration:DATA:AC2 <block>** transfers the AC calibration constants that are used with the 10 MHz filter. The query form returns the current constants in IEEE-488.2 definite block data format. See the AC Flatness Adjustment procedures for more information on the use of this command.

Calibration Commands (cont'd)

- **CALibration:DATA:FILTer** <block> transfers the two calibration constants that are used to determine the frequency points that will be calibrated for the 10 MHz filter. The query form returns the current constants in IEEE-488.2 definite block data format. See the AC Flatness Adjustment procedure for the 10 MHz filter for more information on the use of this command.
- **CALibration:DATA:SKEW** <data> transfers the calibration constant that is used by the skew DAC to synchronize the AFG's DAC's. The query form returns the current constant in IEEE-488.2 definite block data format. See the Skew DAC Adjustment procedure for more information on the use of this command.

NOTE

*The CAL:DATA:FILT and CAL:DATA:SKEW commands are available only on units with firmware rev A.02.00 or higher (use the *IDN? command to determine the AFG's firmware revision).*

- **CALibration:STATE:AC** <state> enables or disables AC corrections using the calibration constants. If <state> is ON, corrections will be used. If <state> is OFF, corrections will not be used.
- **CALibration:STATE:DC** <state> enables or disables DC corrections using the calibration constants. If <state> is ON, corrections will be used. If <state> is OFF, corrections will not be used.
- **CALibration:STATE** <state> enables or disables both AC and DC corrections using the calibration constants. If <state> is ON, corrections will be used. If <state> is OFF, corrections will not be used.
- ***PUD** <data> stores the specified data in non-volatile "protected user data" memory. The data must be sent in IEEE-488.2 definite or indefinite block format. The query form (***PUD?**) returns the current protected user data in IEEE-488.2 definite block format.

Defeating Calibration Security

If the calibration security code is unknown, the security feature can be defeated by disassembling the AFG and moving the jumper on connector J104 (see Figure 3-1) to the unsecured position (left-most pins). To prevent accidental or unauthorized calibration, move the jumper back to the secured position (right-most pins) as soon as the security code has been set to the desired value (use the CALibration:SECure:CODE <code> command). Disassembly instructions can be found in Chapter 5.

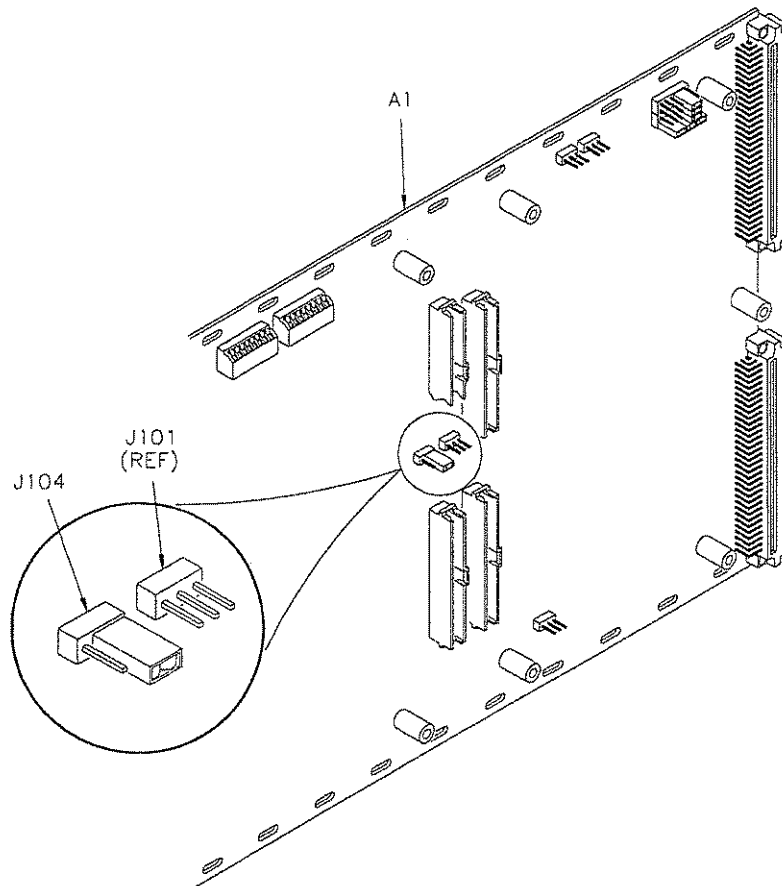

**Figure 3-1. Disabling Calibration Security
(shown in secured position)**

DC Adjustment Procedure

Description

A DC adjustment is performed on the AFG by reading a series of voltages and resistances output by the AFG, then entering those values back into the AFG. After all measurements have been completed, new calibration constants are calculated and stored in non-volatile memory. To ensure accuracy, perform the DC calibration procedure at one year intervals.

This procedure uses a firmware routine to adjust the AFG's DC calibration constants. The CALibration[:DC]:BEGin command starts the DC calibration sequence and the CALibration[:DC]:POINt? command steps the AFG to the next calibration point. All AFG settings are performed by the firmware routine.

NOTE

*If an error occurs at any time during the procedure, abort (*RST) and start over.*

Equipment Setup

- Perform a complete autocalibration on the DMM (unless an autocal has been performed within the last 24 hours)
- Connect the equipment as shown in Figure 3-2

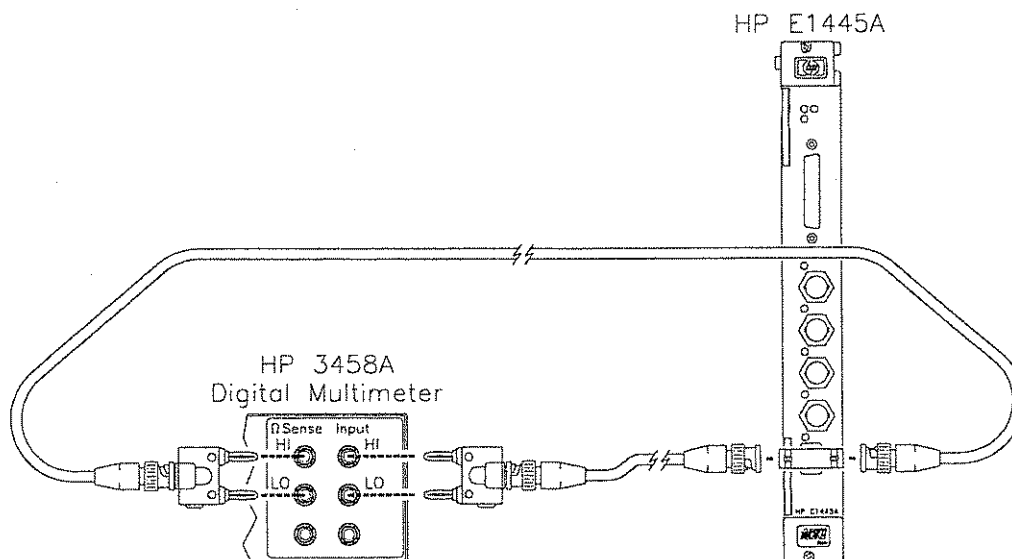

Figure 3-2. DC Adjustment Setup

DC Adjustment Procedure (cont'd)

Adjustment Procedure

1. Reset the AFG:

*RST;*CLS

*Reset AFG and clear
status registers*

2. Enable calibration on the AFG:

CAL:SEC:STAT OFF, <security code>

Cal security off

where <code> is the AFG's security code (factory-set to "E1445A").

3. Send the command to start the DC adjustment routine and wait for the command to complete:

CAL:DC:BEGIN
*OPC?

The AFG will return a "1" when ready.

Repeat steps 4 through 6 for calibration points 1 - 44:

4. If the current calibration point is listed in Table 3-2, set up the DMM as specified. Otherwise, do not change the DMM settings. Note the special instructions for the following points:

Cal Point 31. Immediately after performing the DMM measurement for cal point 30 (and before sending the reading to the AFG) set the DMM range to 10 V. This will prevent an overload when the AFG sets itself for the next reading.

Cal Point 41. Immediately before setting up the DMM for cal point 41, take a reading using the DMM settings for cal point 40. This will provide a DC offset reading. Next, set up the DMM for cal point 41 as specified in Table 3-2. Then use the DC offset reading and Table 3-1 to determine the appropriate DMM range for subsequent calibration points.

Cal Point 43. Same instructions as cal point 41.

DC Adjustment Procedure (cont'd)

Test Procedure (cont'd)

5. Trigger the DMM and note the reading.
6. Send the reading to the AFG:

CAL:DC:POINT? <reading>

where <reading> is the DMM reading from step 5. The AFG will return, in order, the number of the current cal point and an error code. Any non-zero error code indicates a failure.

Table 3-1. DMM Range Setting for Cal Points 41 and 43

Absolute Value of DC Offset	DMM Range
Less than 10 mV	100 Ω
Between 10 mV and 100 mV	1000 Ω
Greater than 100 mV	Offset too high - abort cal

Table 3-2. DC Calibration Points

Cal Point	DMM Settings (changes only)
1	DCV, 10 V range, 10 NPLC
29	1 V range, 20 NPLC
31	10 V*
33	100 mV range
41	4-wire ohms, offset comp on*
43	4-wire ohms, offset comp on*

*See Step 4 of the "DC Adjustment Procedure" for special instructions.

DC Adjustment Procedure (cont'd)

Example Program

```
10! RE-STORE "DC_ADJUST"
30 !This program performs the firmware-guided DC adjustment procedure
40 !for the HP E1445A Arbitrary Function Generator. An HP 3458A DMM
50 !is required.
60 !
70 DIM Results(1:44)
80 INTEGER Cal_point,Max_cal_point,Problem,Err_num
90 !
100 !----- Set up I/O paths -----
110 ASSIGN @Afg TO 70910
120 ASSIGN @Dmm TO 722
130 !
140 !----- Initialize variables -----
150 Max_cal_point=44
160 Cal_point=0
170 Problem=0
180 Secure_code$="E1445A"
190 !
200 !----- Initialize AFG and DMM -----
210 OUTPUT @Afg;"*RST;*CLS"
220 OUTPUT @Dmm;"PRESET NORM"
230 !
240 !----- Connections -----
250 CLEAR SCREEN
260 PRINT "Connect the DMM to the AFG Output (4-wire connection)"
270 DISP "Press 'Continue' when ready"
280 PAUSE
290 CLEAR SCREEN
300 !
310 !----- Setup AFG -----
320 Cal_point=1
330 OUTPUT @Afg;"CAL:SEC:STATE OFF,"&Secure_code$ !Disable cal security
340 OUTPUT @Afg;"CAL:DC:BEGIN" !Begin DC cal
350 OUTPUT @Afg;"*OPC?" !Wait for previous command to finish
360 ENTER @Afg;Not_busy
370 !
380 !----- Start of loop -----
390 REPEAT
400 DISP "DC Calibration in progress: Cal Point #"&VAL$(Cal_point)
410 !
420 GOSUB Setup_dmm !Change DMM settings, if necessary
430 GOSUB Read_dmm !Get reading
440 !
```

(Continued on next page)

DC Adjustment Procedure (cont'd)

Example Program (cont'd)

```
450 IF Cal_point=30 THEN !Special case -- set range now
460 OUTPUT @Dmm;"RANGE 10"
470 END IF
480 !
490 OUTPUT @Afg;"CAL:DC:POINT? ";Reading !Send cal value to AFG
500 ENTER @Afg;This_point,Err_num !Returns current point,err code
510 WAIT .5
520 !
530 Results(Cal_point)=PROUND(Reading,-5)
540 Cal_point=Cal_point+1 !Increment Cal_point
550 UNTIL (Err_num<>0) OR (Cal_point>Max_cal_point)
560 !
570 !----- End of loop -----
580 !If error, print error number & cal point, else send PUD string
590 IF Err_num=0 THEN
600 PRINT "Calibration Successful"
610 !
620 !Store cal information if desired - place desired data inside quotes
630 !in following line and remove !'s.
640 ! Pud$="63 CHARACTERS MAX" !Change Pud$ as desired
650 ! OUTPUT @Afg;"*PUD #0"&Pud$;CHR$(10);END
660 ELSE
670 PRINT "Calibration Error Number "&VAL$(Err_num)&" at Cal Point "&VAL$(Cal_point-1)
680 END IF
690 DISP
700 !
710 !----- Quit -----
720 PAUSE
730 OUTPUT @Afg;"CAL:SEC:STATE ON" !Enable cal security
740 OUTPUT @Afg;"*RST" !Reset AFG
750 OUTPUT @Dmm;"RESET"
760 LOCAL @Dmm !Return DMM to local control
770 !
780 ASSIGN @Afg TO *
790 ASSIGN @Dmm TO *
800 STOP !End of main program
810 !
820 !----- Subroutines -----
830 !
840 Setup_dmm: !
850 SELECT Cal_point
860 CASE =1 !Cal point 1
870 OUTPUT @Dmm;"FUNC DCV;RANGE 10;NPLC 10;OCOMP OFF"
880 CASE =29 !Cal point 29
890 OUTPUT @Dmm;"RANGE 1;NPLC 1"
```

(Continued on next page)

DC Adjustment Procedure (cont'd)

Example Program (cont'd)

```
900 CASE =31                                !Cal point 31
910   OUTPUT @Dmm;"RANGE 10"
920 CASE =33                                !Cal point 33
930   OUTPUT @Dmm;"RANGE .1"
940 CASE =41,=43                             !Cal point 41,43
950   OUTPUT @Dmm;"FUNC DCV;RANGE .1"
960   GOSUB Read_dmm                          !Read voltage - this will
970                                           !Determine ohms range for
980                                           !Measurements that follow
990                                           !
1000  OUTPUT @Dmm;"FUNC OHMF;OCOMP ON"
1010  !
1020  !Determine proper DMM range, using rdg from a few lines up
1030  SELECT ABS(Reading)                     !Use previous Rdg
1040  CASE <=1.0E-2                          !If Rdg<=10mV,
1050    OUTPUT @Dmm;"RANGE 100"
1060  CASE <=1.0E-1                          !IF 10mV<Rdg<=100mV,
1070    OUTPUT @Dmm;"RANGE 1000"
1080  CASE ELSE                              !IF Rdg>100mV,
1090    Problem=1                            !Something is wrong
1100  END SELECT
1110 END SELECT
1120 RETURN
1130 !
1140 Read_dmm: !
1150 OUTPUT @Dmm;"TRIG SGL"
1160 ENTER @Dmm;Reading                      !Get reading
1170 Reading=PROUND(Reading,-10)
1180 RETURN
1190 !
1200 END
```

AC Flatness Adjustment Procedure - 250 kHz Filter

Description

This procedure adjusts the AC calibration constants for the 250 kHz filter. The AC Flatness Test for the 250 kHz filter (see Chapter 2) is performed with AC corrections disabled. The results are used to calculate new calibration constants, which are then transferred to non-volatile memory.

Preliminary Procedure

- Perform a complete autocalibration on the DMM (unless an autocal has been performed within the last 24 hours).
- Determine the calibration constants by performing Test 2-5 (see Chapter 2), with the following modification: After resetting the AFG (step 1), turn off AC corrections using the CAL:STAT:AC OFF command.

Adjustment Procedure

1. Disable calibration security on the AFG:

CAL:SEC:STAT OFF, <security code> *Cal security off*

where <code> is the AFG's security code (factory-set to "E1445A").

2. Verify that the calibration constants determined in the Preliminary Procedure are acceptable (see SUB Valid_cons in the example program).

3. Transfer the calibration constants to the AFG in arbitrary block data format:

CAL:DATA:AC1 <data > *Transfer cal constants*

NOTE

See SUB Adj_flat in the example program to see how step 3 is performed in HP BASIC.

Example Program

An example program that performs the AC flatness adjustment procedures for both filters is listed following the AC flatness adjustment procedure for the 10 MHz filter.

AC Flatness Adjustment Procedure - 10 MHz Filter

Description

This procedure adjusts the AC calibration constants for the 10 MHz filter. The AC Flatness Test for the 10 MHz filter (see Chapter 2) is performed with AC corrections disabled. The results are used to calculate new calibration constants, which are then transferred to non-volatile memory.

Preliminary Procedure

- Perform a complete autocalibration on the DMM (unless an autocal has been performed within the last 24 hours).
- Follow the manufacturer's instructions for calibrating the Power Meter and correcting for the Power Sensor.
- Determine the calibration constants by performing Test 2-6 (see Chapter 2), with the following modification: After resetting the AFG (step 1), turn off AC corrections using the CAL:STAT:AC OFF command.

Adjustment Procedure

1. Disable calibration security on the AFG:

```
CAL:SEC:STAT OFF, <security code>           Cal security off
```

where <security code> is the AFG's security code (factory-set to "E1445A").

2. Verify that the calibration constants determined in the Preliminary Procedure are acceptable (see SUB Valid_cons in the example program).
3. If the firmware revision is A.02.00 or higher (use the *IDN? command to determine the firmware revision), transfer the two constants (4 and 25000) that determine the frequencies to be calibrated:

```
CAL:DATA:FILT <data>
```

NOTE

See SUB Load_magic_num in the example program to see how step 3 is performed in HP BASIC.

AC Flatness Adjustment Procedure - 10 MHz Filter (cont'd)

Adjustment Procedure (cont'd)

NOTE

*Rev A.02.00 (use the *IDN? command to determine the firmware revision) allows the 10 MHz filter to be replaced with a filter that has a lower cutoff frequency (the 10 MHz filter must be replaced at the factory). If the 10 MHz filter has been replaced, change the value for Max_freq in line 570 of the example program to the new cutoff frequency. Changing Max_freq may change the constants that are sent with the CAL:DATA:FILT command in step 3 (see SUB Load_magic_num).*

4. Transfer the calibration constants to the AFG in arbitrary block data format:

CAL:DATA:AC2 <data >

Transfer cal constants

NOTE

See SUB Adj_flat in the example program to see how step 4 is performed in HP BASIC.

AC Flatness Adjustment Procedure (cont'd)

Example Program

```
10! RE-STORE "AC_FLAT"
30 !This program performs the AC flatness adjustment procedure for
40 !the HP E1445A Arbitrary Function Generator. An HP 3458A DMM
50 !and an HP 8902A Measuring Receiver are required.
60 !
70 !To perform the flatness measurements without adjustments, change
80 !Mode$ to "M" below.
90 !
100 COM @Afg,@Dmm,@Pwr_mtr,@Analyzer,Secure_code$[12]
110 COM /Flat/ INTEGER Num_points,Max_con
120 CLEAR SCREEN
130 !
140 !----- Set up I/O paths -----
150 ASSIGN @Afg TO 70910
160 ASSIGN @Dmm TO 722
170 ASSIGN @Pwr_mtr TO 714
180 Mode$="M"                                !'M' means measure, 'A' means adjust
190 Secure_code$="E1445A"                    !Calibration security code
200 !
210 CALL Flatness("250KHZ",Mode$)
220 CALL Flatness("10MHZ",Mode$)
230 !
240 !----- QUIT -----
250 !RESET INSTRUMENTS
260 OUTPUT @Afg,"*RST;*CLS"
270 OUTPUT @Pwr_mtr;"IP"
280 OUTPUT @Dmm;"RESET"
290 LOCAL @Dmm
300 LOCAL @Pwr_mtr
310 !
320 !CLOSE I/O PATHS
330 ASSIGN @Afg TO *
340 ASSIGN @Dmm TO *
350 ASSIGN @Pwr_mtr TO *
360 STOP
370 !
380 END
390 !
400 !***** End Of Main Program *****
410 !
```

(Continued on next page)

AC Flatness Adjustment Procedure (cont'd)

Example Program (cont'd)

```
420 Flatness:SUB Flatness(Filter$,Mode$)
430   COM @Afg,@Dmm,@Pwr_mtr,@Analyzer,Secure_code$
440   COM /Flat/ INTEGER Num_points,Max_con
450   INTEGER Filter,Ac_cal_int(1:2)
460   CLEAR SCREEN
470   !
480   !----- Initialize variables -----
490   Ampl_dbm=24                               !AFG max amplitude
500   !
510   !----- Main Program -----
520   IF Filter$="250KHZ" THEN
530     Num_points=25                           !Number of test points
540     Max_freq=2.50E+5
550   ELSE                                       !Else, 10M filter will be used
560     Num_points=27                           !Number of test points
570     Max_freq=1.08E+7
580   END IF
590   PRINT "FILTER = "&Filter$
600   !
610   ALLOCATE Test_freq(1:Num_points),Results(1:Num_points)
620   !
630   !Determine test frequencies
640   Step_size=Max_freq/Num_points
650   FOR I=1 TO Num_points
660     Test_freq(I)=Step_size*I
670   NEXT I
680   !
690   GOSUB Setup_afg
700   CALL Meas_flat(Test_freq(*),Results(*),Filter$)
710   !
720   IF Mode$="A" THEN
730     CALL Adj_flat(Results(*),Filter$,Test_freq(Num_points))
740   END IF
750   !
760   DEALLOCATE Test_freq(*),Results(*)
770   SUBEXIT
780   !
790 Setup_afg: !
800   OUTPUT @Afg,"*RST,*CLS"
810   WAIT .5
820   !
```

(Continued on next page)

AC Flatness Adjustment Procedure (cont'd)

Example Program (cont'd)

```
830 OUTPUT @Afg;"FUNC SIN;"; !Sine
840 OUTPUT @Afg;":VOLT "&VAL$(Ampl_dbm)&"DBM;"; !Set amplitude
850 OUTPUT @Afg;":OUTP:LOAD 50 !50 ohm load
860 OUTPUT @Afg;"CAL:STATE:AC "&VAL$(Mode$="M") !Turn AC corrections
870 !On if meas mode, or
880 !Off if adjust mode
890 OUTPUT @Afg;"OUTP:FILT:FREQ "&Filter$ !Set filter
900 OUTPUT @Afg;"OUTP:FILT ON"
910 OUTPUT @Afg;"INIT:IMM"
920 WAIT 1
930 RETURN
940 SUBEND
950 !
960 Meas_flat:SUB Meas_flat(Test_freq(*),Results(*),Filter$)
970 COM @Afg,@Dmm,@Pwr_mtr,@Analyzer,Secure_code$
980 COM /Flat/ INTEGER Num_points,Max_con
990 INTEGER Dmm_setup,Pm_setup
1000 !
1010 !----- Initialize variables -----
1020 Ref_freq=1000 !Reference frequency
1030 Xover_freq=1.E+5 !Crossover frequency
1040 Dmm_setup=1
1050 Pm_setup=1
1060 !
1070 !----- Get ref readings -----
1080 !
1090 PRINTER IS CRT
1100 !Get DMM reading at ref freq
1110 OUTPUT @Afg;"FREQ "&VAL$(Ref_freq)
1120 CALL Dmm_flat_rdg(Ref_freq,Dmm_ref,Dmm_setup)
1130 PRINT "DMM REF READING =";Dmm_ref
1140 !
1150 !If 10MHZ filter, get DMM & PWR MTR readings at crossover freq
1160 IF Filter$="10MHZ" THEN
1170 OUTPUT @Afg;"FREQ "&VAL$(Xover_freq)
1180 !
1190 CALL Dmm_flat_rdg(Xover_freq,Dmm_xover,Dmm_setup)
1200 PRINT "DMM XOVER READING =";Dmm_xover
1210 CALL Pm_flat_rdg(Xover_freq,Pm_xover,Pm_setup)
1220 Correct_factor=Dmm_xover/Pm_xover
1230 PRINT "POWER METER XOVER READING =";Pm_xover
1240 ELSE
1250 Correct_factor=1
1260 END IF
```

(Continued on next page)

AC Flatness Adjustment Procedure (cont'd)

Example Program (cont'd)

```
1270 Offset_factor=Dmm_ref
1280 PRINT "CORRECTION FACTOR =";Correct_factor
1290 PRINT
1300 PRINT
1310 PRINTER IS CRT
1320 !
1330 !
1340 !----- Perform measurements at test freqs -----
1350 !
1360 PRINT "  FREQ  READING (V)  ERROR (dBm)"
1370 PRINT "  ---  ---  ---"
1380 PRINT
1390 !
1400 FOR I=1 TO Num_points
1410 !Set AFG to test freq
1420   IF Test_freq(I)>1.073741824E+7 THEN           !SCPI can't do 10.8MHz
1430     GOSUB Max_afg_freq                         !so use register commands
1440   ELSE
1450     OUTPUT @Afg;"FREQ "&VAL$(Test_freq(I))
1460   END IF
1470   !
1480   !Get reading
1490   IF Filter$="250KHZ" THEN                       !If 250K filter,
1500     CALL Dmm_flat_rdg(Test_freq(I),Reading,Dmm_setup)
1510   ELSE                                           !If 10M filter,
1520     CALL Pm_flat_rdg(Test_freq(I),Reading,Pm_setup)
1530   END IF
1540   Flat_result=Reading*Correct_factor             !Adjust reading
1550   !Convert to dBm error
1560   Flat_error_dbm=PROUND((20*LGT(Flat_result)+13.0103)-(20*LGT(Offset_factor)+13.0103),-4)
1570   Results(I)=Flat_error_dbm                     !Store result in array
1580   !
1590   Freq$=FNFormat_num$(Test_freq(I),1.E+5,9,"M6D","MD.2DESZ")
1600   Result_v$=FNFormat_num$(Flat_result,1.E+3,9,"M2D.5D","MD.3DESZ")
1610   Result_dbm$=FNFormat_num$(Flat_error_dbm,10,9,"M2D.5D","MD.3DESZ")
1620   PRINT USING "9A,5X,9A,5X,9A";Freq$,Result_v$,Result_dbm$
1630 NEXT I                                         !End of loop
1640 PRINT
1650 SUBEXIT
1660 !
1670 Max_afg_freq: !Set AFG to 10.8MHz with register level commands
1680   OUTPUT @Afg;"FREQ MAX"                       !Get close with SCPI
```

(Continued on next page)

AC Flatness Adjustment Procedure (cont'd)

Example Program (cont'd)

```
1690 !Use register commands to get to 10.8MHz
1700 OUTPUT @Afg;"DIAG:POKE #HE000A1,8,0"      !PHASE_A1,0
1710 OUTPUT @Afg;"DIAG:POKE #HE000A3,8,126"    !PHASE_A2,126
1720 OUTPUT @Afg;"DIAG:POKE #HE000A5,8,95"     !PHASE_A3,95
1730 OUTPUT @Afg;"DIAG:POKE #HE000A7,8,64"     !PHASE_A4,64
1740 OUTPUT @Afg;"DIAG:POKE #HE0008D,8,0"      !LDSTBIND,0
1750 WAIT .1
1760 RETURN
1770 SUBEND
1780 !
1790 Adj_flat:SUB Adj_flat(Results(*),Filter$,Max_freq)
1800 COM @Afg,@Dmm,@Pwr_mtr,@Analyzer,Secure_code$
1810 COM /Flat/ INTEGER Num_points,Max_con
1820 INTEGER Cal_problem,Problem
1830 !
1840 Cal_problem=0
1850 Scale_factor=1000
1860 STATUS @Afg,3;Address                      !Get path address
1870 !
1880 ALLOCATE INTEGER Ac_cal_cons(1:Num_points)
1900 FOR I=1 TO Num_points
1910   Ac_cal_cons(I)=Results(I)*Scale_factor    !Scale results array
1920 NEXT I
1930 !
1940 CALL Valid_cons(Results(*),Cal_problem)    !Make sure constants are within range
1960 !Transfer "magic numbers" if 10MHz filter
1970 IF Filter$<>"250KHZ" THEN
1980   Load_magic_num(Max_freq,Problem)
1990   IF Problem THEN
2000     PRINT "Problem occurred in Load_magic_num."
2010     Cal_problem=1
2020   END IF
2030 END IF
2040 !
2050 IF NOT Cal_problem THEN
2060   OUTPUT @Afg;"ABORT"                      !Abort waveform
2070   !
2080   !Store cal constants into eeprom (format off)
2090   OUTPUT @Afg;"CAL:SEC:STATE OFF",&Secure_code$ !Enable cal
2100   ASSIGN @Afg TO Address;FORMAT OFF
2110   IF Filter$="250KHZ" THEN
2120     PRINT "Changed 250KHz Cal constants"
2130     OUTPUT @Afg USING "#,K";"CAL:DATA:AC1 #0"
2140   ELSE
2150     PRINT "Changed 10MHz Cal constants"
2160     OUTPUT @Afg USING "#,K";"CAL:DATA:AC2 #0"
2170   END IF
```

(Continued on next page)

AC Flatness Adjustment Procedure (cont'd)

Example Program (cont'd)

```
2180     OUTPUT @Afg;Ac_cal_cons(*)           !Load array
2190     OUTPUT @Afg USING "#,K";CHR$(10),END  !LF,EOI
2200     !
2210     ASSIGN @Afg TO Address                !Back to default attributes
2220     OUTPUT @Afg;"CAL:SEC:STATE ON"        !Disable cal
2230     !
2240     PRINT "Flatness calibration constants stored to EEPROM"
2250     ELSE
2260     PRINT "Flatness calibration constants NOT stored to EEPROM"
2270     END IF
2280     !
2290     DISP "Press 'Continue' when ready"
2300     PAUSE
2310     DISP
2320     !
2330     DEALLOCATE Ac_cal_cons(*)
2340     SUBEND
2350     !
2360     Dmm_flat_rdg:SUB Dmm_flat_rdg(Freq,Rdg,INTEGER Dmm_setup)
2370     COM @Afg,@Dmm,@Pwr_mtr,@Analyzer,Secure_code$
2380     COM /Flat/ INTEGER Num_points,Max_con
2390     !
2400     IF Dmm_setup THEN                    !If true, set up DMM
2410                                         !otherwise, skip setup
2420     DISP "Connect DMM to AFG Output (with 50ohm termination), then press 'Continue'"
2430     PAUSE
2440     DISP
2450     OUTPUT @Dmm;"PRESET NORM;FUNC ACV;SETACV SYNC;TRIG HOLD"
2460     OUTPUT @Dmm;"RANGE 10;DELAY .1"
2470     WAIT 1
2480     Dmm_setup=0                          !Clear flag so setup is only performed once
2500     END IF
2510     !
2520     OUTPUT @Dmm;"ACBAND "&VAL$(Freq*.9)&","&VAL$(Freq*1.1)
2530     WAIT .5
2540     OUTPUT @Dmm;"TRIG SGL"
2550     ENTER @Dmm;Rdg
2560     SUBEND
2570     !
2580     Pm_flat_rdg:SUB Pm_flat_rdg(Freq,Rdg,INTEGER Pm_setup)
2590     COM @Afg,@Dmm,@Pwr_mtr,@Analyzer,Secure_code$
2600     COM /Flat/ INTEGER Num_points,Max_con
2610     !
2620     IF Pm_setup THEN                      !If true, then set up Power Meter
2630                                         !otherwise skip setup
```

(Continued on next page)

AC Flatness Adjustment Procedure (cont'd)

Example Program (cont'd)

```
2640     DISP "Connect Power Meter to AFG Output, then press 'Continue'"
2650     PAUSE
2660     DISP
2670     OUTPUT @Pwr_mtr;"IP"                !Instrument preset
2680     OUTPUT @Pwr_mtr;"AU M4 WT"         !Auto operation, RF power, watts
2690     WAIT .5
2700     Pm_setup=0                          !Clear flag so that setup
2710                                           !is only performed once
2720     END IF
2730     OUTPUT @Pwr_mtr;VAL$(Freq/1.E+6)&"MHZ" !Expected frequency
2740     OUTPUT @Pwr_mtr;"T3"               !Trigger Pwr Meter w/settling
2750     ENTER @Pwr_mtr;Rdg                 !Get reading
2760     !
2770     Rdg=SQRT(ABS(Rdg)*50)               !Convert from watts to volts
2780     SUBEND
2790     !
2800     Read_dc_cal_con:SUB Read_dc_cal_con(Cal_real(*))
2810     COM @Afg,@Dmm,@Pwr_mtr,@Analyzer,Secure_code$
2820     COM /Flat/ INTEGER Num_points,Max_con
2830     !
2840     Max_con=25
2850     ALLOCATE Scale(1:12),INTEGER Cal_reflect(1:Max_con)
2860     IF SIZE(Cal_real,1)<Max_con THEN
2870         PRINT "PASS PARAMETER NOT DIMENSIONED LARGE ENOUGH"
2880         BEEP
2890     END IF
2900     !
2910     ISET CAL CONSTANT SCALE FACTORS
2920     DATA 7E6 ,7E6 ,1E7 ,1E7 ,1E6
2930     ! M_plus,M_minus,M_adj,M_off,M_cust
2940     DATA 1E6 ,1E6 ,1E10 ,1E6 ,1E4
2950     ! Vpwr ,Vbuf ,M_sub, B_sum, dB ERROR
2960     DATA 4 ,0
2970     ! P&N BASE
2980     READ Scale(*)
2990     !
3000     OUTPUT @Afg;"CAL:SEC:STATE OFF,"&Secure_code$
3010     !
3020     !Read cal constants back
3030     OUTPUT @Afg;"CAL:DATA?"
3040     ENTER @Afg USING "4A,34(W)";Dummy$[1,4],Cal_reflect(*)
3050     !
3060     OUTPUT @Afg;"CAL:SEC:STATE ON"
3070     !
```

(Continued on next page)

AC Flatness Adjustment Procedure (cont'd)

Example Program (cont'd)

```
3080 FOR I=1 TO Max_con
3090   Cal_real(I)=Cal_reflect(I)
3100   IF I=1 THEN Cal_real(I)=Cal_reflect(I)/Scale(1)   ! M_plus
3110   IF I=2 THEN Cal_real(I)=Cal_reflect(I)/Scale(11)  ! P_base
3120   IF I=3 THEN Cal_real(I)=Cal_reflect(I)/Scale(2)   ! M_minus
3130   IF I=4 THEN Cal_real(I)=Cal_reflect(I)/Scale(3)   ! M_adj
3140   IF I=5 THEN Cal_real(I)=Cal_reflect(I)/Scale(11)  ! N_base
3150   IF I>5 AND I<13 THEN Cal_real(I)=Cal_real(I)/Scale(10) !Filter and
3160                                           ! ATTN gain errors
3170   IF I=13 THEN Cal_real(I)=Cal_reflect(I)/Scale(4)   ! M_off
3180   IF I=14 THEN Cal_real(I)=Cal_reflect(I)/Scale(5)   ! M_cust
3190   IF I=15 THEN Cal_real(I)=Cal_reflect(I)/Scale(6)   ! Vpwro
3200   IF I=16 THEN Cal_real(I)=Cal_reflect(I)/Scale(6)   ! Vpwri
3210   IF I=17 THEN Cal_real(I)=Cal_reflect(I)/Scale(7)   ! Vbuf
3220   IF I=18 THEN Cal_real(I)=Cal_reflect(I)/Scale(8)   ! M_sum
3230   IF I=19 THEN Cal_real(I)=Cal_reflect(I)/Scale(9)   ! B_sum
3240                                           ! Z_inc_0db (not scaled)
3250                                           ! Z_inc_14db (not scaled)
3260   IF I>21 THEN Cal_real(I)=Cal_real(I)/Scale(10)   ! Zout gain errors
3270 NEXT I
3280 !
3290 DEALLOCATE Scale(*),Cal_reflect(*)
3300 SUBEND
3310 !
3320 Valid_cons:SUB Valid_cons(Results*),INTEGER Cal_problem)
3330 COM @Afg,@Dmm,@Pwr_mtr,@Analyzer,Secure_code$
3340 COM /Flat/ INTEGER Num_points,Max_con
3360 Max_con=25
3370 Cal_problem=0
3380 !
3390 ALLOCATE Cal_real(1:Max_con)
3400 !
3410 CALL Read_dc_cal_con(Cal_real(*))
3420 !CHECK FOR VALID CAL
3430 M_plus=Cal_real(1)           ! key cal constant
3440 P_base=Cal_real(2)           ! +base
3450 M_minus=Cal_real(3)          ! key cal constant
3460 M_adj=Cal_real(4)            ! key cal constant
3470 N_base=Cal_real(5)           ! -base
3480 !
3490 !Check that cal constants are reasonable--if not, use nominal values
3500 IF (M_plus<-.005 OR M_plus>-.003) THEN M_plus=-3.834E-3
3510 IF (M_minus<-.005 OR M_minus>-.003) THEN M_minus=-3.834E-3
3520 IF (M_adj<-.0012 OR M_adj>-.0009) THEN M_adj=-.001021
3530 IF (P_base<3180 OR P_base>3889) THEN P_base=3535
3540 IF (N_base<10 OR N_base>245) THEN N_base=128
3550 !
```

(Continued on next page)

AC Flatness Adjustment Procedure (cont'd)

Example Program (cont'd)

```
3560 !Check for valid cal
3570 Max_filter_db=MAX(Cal_real(6),Cal_real(7),0)
3580 Min_filter_db=MIN(Cal_real(6),Cal_real(7),0)
3590 !
3600 Max_attn_db=0
3610 Min_attn_db=0
3620 FOR I=8 TO 12
3630     IF Cal_real(I)>0 THEN
3640         Max_attn_db=Max_attn_db+Cal_real(I)
3650     ELSE
3660         Min_attn_db=Min_attn_db+Cal_real(I)
3670     END IF
3680 NEXT I
3690 !
3700 Max_zout_db=MAX(Cal_real(22),Cal_real(23),Cal_real(24),Cal_real(25),0)
3710 Min_zout_db=MIN(Cal_real(22),Cal_real(23),Cal_real(24),Cal_real(25),0)
3720 !
3730 Max_pos_gain_db=-1*MAX(Results(*),0)-(Max_filter_db+Max_attn_db+Max_zout_db)-1.02
3740 Min_pos_gain_db=-1*MIN(Results(*),0)-(Min_filter_db+Min_attn_db+Min_zout_db)-1.02
3750 !
3760 !Calculate P_inc's and N_inc's
3770 Max_p_inc=10*(10^((Max_pos_gain_db)/20)-1)/M_plus
3780 Min_p_inc=10*(10^((Min_pos_gain_db)/20)-1)/M_plus
3790 Max_n_inc=(Max_p_inc*(M_plus-M_minus))/M_adj
3800 Min_n_inc=(Min_p_inc*(M_plus-M_minus))/M_adj
3810 Max_gain_dac=P_base+Max_p_inc
3820 Min_gain_dac=P_base+Min_p_inc
3830 Max_to_dac=N_base+Max_n_inc
3840 Min_to_dac=N_base+Min_n_inc
3850 !
3860 ! PRINT "GAIN DAC EXTREMES: MAX,MIN = "&VAL$(PROUND(Max_gain_dac,-1))&","
    "&VAL$(PROUND(Min_gain_dac,-1))
3870 ! PRINT "TURNOVER DAC EXTREMES: MAX,MIN = "&VAL$(PROUND(Max_to_dac,-1))&","
    "&VAL$(PROUND(Min_to_dac,-1))
3880 !
3890 IF Max_gain_dac>4075 OR Min_gain_dac<20 THEN ! If out of range
3900     Cal_problem=1 ! Set flag
3910     PRINT "GAIN DAC OUT OF RANGE"
3920 END IF
3930 !
3940 IF Max_to_dac>247 OR Min_to_dac<8 THEN ! If out of range
3950     Cal_problem=1 ! Don't store constants
3960     PRINT "TURNOVER DAC OUT OF RANGE"
3970 END IF
3980 !
3990 DEALLOCATE Cal_real(*)
4000 SUBEND
4010 !
```

(Continued on next page)

AC Flatness Adjustment Procedure (cont'd)

Example Program (cont'd)

```
4020 SUB Syst_err(Address)
4030   COM @Afg,@Dmm,@Pwr_mtr,@Analyzer,Secure_code$
4040   COM /Flat/ INTEGER Num_points,Max_con
4050   DIM Message$[256]
4060   REPEAT
4070     OUTPUT Address;"SYST:ERR?"
4080     ENTER Address;Code,Message$
4090     PRINT Code,Message$
4100   UNTIL NOT Code
4110 SUBEND
4120 !
4130 Load_magic_num:SUB Load_magic_num(Max_freq,OPTIONAL INTEGER Problem)
4140   COM @Afg,@Dmm,@Pwr_mtr,@Analyzer,Secure_code$
4150   COM /Flat/ INTEGER Num_points,Max_con
4160   INTEGER Num_cal_points,N,Div
4170   ALLOCATE Id$[50],INTEGER Block(1:2),Ac_int(1:2)
4180   !
4190   !Check firmware rev - if A.01.00 then exit
4200   OUTPUT @Afg;"*IDN?"
4210   ENTER @Afg;Id$
4220   IF POS(Id$,"A.01.00") THEN SUBEXIT
4230   !
4240   STATUS @Afg,3;Address                               !Get path address
4250   !
4260   IF NPAR>1 THEN Problem=0
4270   Num_cal_points=27
4280   !
4290   Cal_step=Max_freq/Num_cal_points                    !Step size
4300   !
4310   !Calculate N
4320   N=INT(LGT(Cal_step/32768)/LGT(2))+1
4330   N=MAX(N,1)
4340   N=MIN(N,8)
4350   !
4360   !Calculate Div
4370   Div=Cal_step/(2^N)
4380   Div=MAX(Div,1)
4390   Div=MIN(Div,32767)
4400   !
4410   IF Cal_step<>PROUND(((2^N)*Div),4) THEN
4420     IF NPAR>1 THEN Problem=1
```

(Continued on next page)

AC Flatness Adjustment Procedure (cont'd)

Example Program (cont'd)

```
4430 ELSE
4440   Block(1)=N
4450   Block(2)=Div
4460   !
4470   OUTPUT @Afg;"CAL:SEC:STATE OFF,"&Secure_code$   !Enable cal
4480   ASSIGN @Afg TO Address;FORMAT OFF
4490   OUTPUT @Afg USING "#,K";"CAL:DATA:FILTER #0"
4500   OUTPUT @Afg;Block(*)
4510   OUTPUT @Afg USING "#,K";CHR$(10),END
4520   ASSIGN @Afg TO Address                               !Back to default attributes
4530   OUTPUT @Afg;"CAL:SEC:STATE ON"                       !Disable cal
4540   !
4550   PRINT "MAGIC NUMBERS STORED: ";N,Div
4560   PRINT
4580 END IF
4590 SUBEND
4600 !
4610 Read_ac_cal_int:SUB Read_ac_cal_int(INTEGER Ac_cal_int(*))
4620 COM @Afg,@Dmm,@Pwr_mtr,@Analyzer,Secure_code$
4630 COM /Flat/ INTEGER Num_points,Max_con
4640 !
4650 ALLOCATE Id$[50]
4660 !
4670 OUTPUT @Afg;"IDN?"
4680 ENTER @Afg;Id$
4690 !
4700 IF POS(Id$,"A.01.00") THEN
4710   Ac_cal_int(1)=4
4720   Ac_cal_int(2)=25000
4730   SUBEXIT
4740 END IF
4750 !
4760 Max_con=2
4770 !
4780 ! IF SIZE(Ac_cal_int,1)<>Max_con OR RANK(Ac_cal_int)<>1 THEN
4790 !
4800 STATUS @Afg,3;Address
4810 !
4820 OUTPUT @Afg;"CAL:SEC:STATE OFF,"&Secure_code$
4830 OUTPUT @Afg;"CAL:DATA:FILTER?"
4840 ASSIGN @Afg TO Address;FORMAT OFF
4850 ENTER @Afg USING "3A,2(W)";Dummy$[1,3],Ac_cal_int(*)
4860 ASSIGN @Afg TO Address
4870 OUTPUT @Afg;"CAL:SEC:STATE ON"
4880 !
4890 PRINT Ac_cal_int(*)
4900 SUBEND
```

(Continued on next page)

AC Flatness Adjustment Procedure (cont'd)

Example Program (cont'd)

```
4910 !
4920 SUB Security_code
4930 COM @Afg,@Dmm,@Pwr_mtr,@Analyzer,Secure_code$
4940 COM /Flat/ INTEGER Num_points,Max_con
4950 CLEAR SCREEN
4960 OUTPUT @Afg;"*RST;*CLS"
4970 !
4980 Valid=0
4990 REPEAT
5000 Secure_code$="E1445A"
5010 INPUT "Enter your security code <default is 'E1445A'>",Secure_code$
5020 Secure_code$=TRIM$(Secure_code$)
5030 Check_sec_code(Valid)
5040 UNTIL Valid
5050 SUBEND
5060 !
5070 !
5080 SUB Check_sec_code(Valid)
5090 COM @Afg,@Dmm,@Pwr_mtr,@Analyzer,Secure_code$
5100 COM /Flat/ INTEGER Num_points,Max_con
5110 DIM Message$[255]
5120 Valid=0
5130 CLEAR SCREEN
5140 DISP "Verifying security code..."
5150 WAIT 1
5160 OUTPUT @Afg;"CAL:SEC:STAT OFF,"&Secure_code$
5170 OUTPUT @Afg;"SYST:ERR?"
5180 ENTER @Afg;Code,Message$
5190 DISP
5200 !
5210 IF Code<>0 THEN
5220 BEEP 1000,.1
5230 PRINT "Invalid security code -- try again"
5240 OUTPUT @Afg;"*RST;*CLS"
5250 DISP "Press 'Continue'"
5260 PAUSE
5270 SUBEXIT
5280 ELSE
5290 Valid=1
5300 PRINT "Security code accepted"
5310 WAIT 1
5320 OUTPUT @Afg;"*RST;*CLS"
5330 END IF
5340 CLEAR SCREEN
5350 SUBEND
5360 !
5370 !
```

(Continued on next page)

AC Flatness Adjustment Procedure (cont'd)

Example Program (cont'd)

```
5380 Format_num:DEF FNFormat_num$(Value,Not_exp_max,INTEGER Length,Not_exp_img$,Exp_img$)
5390  INTEGER Diff
5400  SELECT ABS(Value)
5410  CASE <1.E-9,>=1.E+10
5420    IF NOT POS(Exp_img$,"ZZ") THEN
5430      OUTPUT String$ USING Exp_img$&"Z,#";Value
5440    ELSE
5450      OUTPUT String$ USING Exp_img$&"#";Value
5460    END IF
5470  CASE <1.E-4,>=Not_exp_max
5480    OUTPUT String$ USING Exp_img$&"#";Value
5490  CASE ELSE
5500    OUTPUT String$ USING Not_exp_img$&"#";Value
5510  END SELECT
5520  !
5530  Diff=Length-LEN(String$)
5540  IF Diff>0 THEN String$=RPT$(" ",Diff)&String$
5550  RETURN String$
5560 FNEND
5570 !
5580 !
```

Skew DAC Adjustment Procedure

Description

This procedure compensates for time delays between the AFG's two DACs. The skew setting which produces the lowest second harmonic amplitude is found and loaded into non-volatile memory.

Equipment Setup

- Connect the equipment as shown in Figure 3-3
- Set up the Spectrum Analyzer:

Center Frequency = 8 MHz

Frequency Span = 3.2 kHz

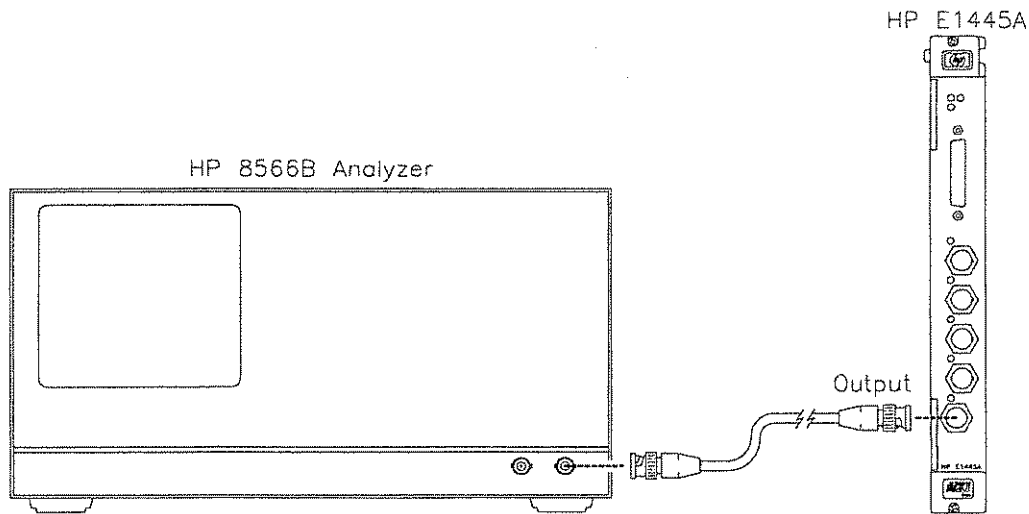

Figure 3-3. Skew DAC Adjustment Setup

Adjustment Procedure

1. Reset the AFG:

*RST

Skew DAC Adjustment Procedure (cont'd)

Adjustment Procedure (cont'd)

2. Set up the AFG to output an 11 dBm, 4 MHz sine wave:

```
FUNC SIN;  
:VOLT 11 DBM;  
:FREQ 4E6  
INIT:IMM
```

3. Load an initial value of 128 into the delay DAC:

```
DIAG:POKE #HE0000B,8,2  
DIAG:POKE #HE0000D,8,128  
DIAG:POKE #HE0000B,8,7  
DIAG:POKE #HE0000D,8,8
```

4. With the Spectrum Analyzer, locate and center the second harmonic. Then, reduce the frequency span to 2 kHz.
5. Find the delay DAC setting that minimizes the amplitude of the second harmonic (see the example program).
6. Disable calibration security on the AFG:

```
CAL:SEC:STAT OFF, <security code>           Cal security off
```

where <code> is the AFG's security code (factory-set to "E1445A").

7. Transfer the calibration constant (DAC setting) to the AFG in arbitrary block data format:

```
CAL:DATA:SKEW <data >                       Transfer cal constant
```

NOTE

See the example program to see how step 7 is performed in HP BASIC.

8. Enable calibration security on the AFG:

```
CAL:SEC:STAT ON                               Cal security on
```

Skew DAC Adjustment Procedure (cont'd)

Example Program

```
10 ! RE-STORE "SKEW_CAL"
20 COM @Afg,@Analyzer,Secure_code$[20]
30 INTEGER Dac_bits,Dac_word,Min_word,Max_word,Step_size,Harmonic
40 INTEGER Loc_min,Cal_word,Search_loop,Max_search_loop,Filter,Skew_con
50 DIM Id$[50]
60 !
70 !----- Assign I/O paths -----
80 ASSIGN @Afg TO 70910
90 ASSIGN @Analyzer TO 718
100 !
110 !----- Check firmware rev -----
120 !Rev A.01.00 does not support this cal procedure
130 OUTPUT @Afg;"*IDN?"
140 ENTER @Afg;Id$
150 !
160 IF POS(Id$,"A.01.00") THEN
170     PRINT "This rev does not support skew DAC calibration."
180     STOP
190 END IF
200 !
210 !----- Initialize variables -----
220 Secure_code$="E1445A"           !AFG security code
230 Harmonic=2                    !Harmonic to be minimized
240 Filter=0                      !No filter
250 Freq=4.E+6                    !AFG frequency (Hz)
260 Amp_in_dbm=11                 !AFG amplitude (dBm)
270 Search_span$=VAL$(Freq*Harmonic*4.00E-4) !Initial Spec Analyzer span
280 Test_span$="2000"            !Span used for measurements
290 !
300 Dac_bits=8
310 Start_step_size=16
320 Step_size=Start_step_size
330 Max_search_loop=4
340 Dac_word=2^(Dac_bits-1)       !Initial Dac_word
350 Max_word=2^(Dac_bits)        !Initial max
360 Min_word=0                   !Initial min
370 !
380 !----- Test connections -----
390 PRINT "Connect Spectrum Analyzer to AFG Ouput."
400 DISP "Press 'Continue' when ready"
410 PAUSE
420 CLEAR SCREEN
430 !
```

(Continued on next page)

Skew DAC Adjustment Procedure (cont'd)

Example Program (cont'd)

```
440 !----- Perform cal -----
450 OUTPUT @Afg;"*RST;*CLS;*OPC?"           !Reset AFG
460 ENTER @Afg;Result
470 !
480 !Set up Spec Analyzer
490 Setup_spec(VAL$(Amp_in_dbm-2)&"DM",VAL$(Freq*Harmonic),Search_span$)
500 !
510 !Set up AFG
520 OUTPUT @Afg;"FUNC SIN;";
530 OUTPUT @Afg;":VOLT "&VAL$(Amp_in_dbm)&"DBM;";
540 OUTPUT @Afg;":FREQ "&VAL$(Freq)
550 OUTPUT @Afg;"INIT:IMM"
560 Load_delay_dac(Dac_word)                 !Load constant into register
570 !
580 !Capture and center 2nd harmonic
590 Get_2nd_harm(Test_span$)
600 !
610 !Begin cal search loop
620 Search_loop=1
630 REPEAT
640   ALLOCATE INTEGER Word_array(0:((Max_word-Min_word)/Step_size))
650   ALLOCATE REAL Meas_array(0:((Max_word-Min_word)/Step_size))
660   Array_counter=0
670   !
680   PRINT "LOOP =",Search_loop
690   PRINT
700   PRINT "CONSTANT"," READING"
710   PRINT "-----"," ----"
720   !
730   !Find constant that produces minimum 2nd harmonic
740   FOR I=Min_word TO Max_word STEP Step_size
750     IF I=256 THEN
760       Dac_word=255
770     ELSE
780       Dac_word=I
790     END IF
800     Load_delay_dac(Dac_word)               !Load constant into register
810     Word_array(Array_counter)=Dac_word
820     !
830     !Measure 2nd_harmonic, store in array
840     Meas_2nd_harm(Meas_array(Array_counter))
850     PRINT Word_array(Array_counter),DROUND(Meas_array(Array_counter),8)
860     Array_counter=Array_counter+1
870   NEXT I
880   !
```

(Continued on next page)

Skew DAC Adjustment Procedure (cont'd)

Example Program (cont'd)

```
890 !Set variables for next loop
900 MAT SEARCH Meas_array,LOC MIN;Loc_min !Get location of min rdg
910 Cal_word=Word_array(Loc_min)
920 Min_word=Word_array(MAX(0,Loc_min-1))
930 Max_word=Word_array(MIN((SIZE(Word_array,1)-1),Loc_min+1))
940 Step_size=Step_size/INT(SQRT(Start_step_size)+.5) !Reduce step size
950 !
960 PRINT
970 PRINT
980 !
990 DEALLOCATE Meas_array(*),Word_array(*)
1000 Search_loop=Search_loop+1
1010 UNTIL Step_size<1
1020 !
1030 PRINT "CAL CONSTANT =";Cal_word
1040 PRINT
1050 Wrt_skew_con(Cal_word) !Write word to eeprom
1060 !
1070 !----- Quit -----
1080 OUTPUT @Afg;"*RST;*CLS"
1090 ASSIGN @Afg TO *
1100 ASSIGN @Analyzer TO *
1110 STOP
1120 END
1130 !
1140 Load_delay_dac:SUB Load_delay_dac(INTEGER Delay_dac)
1150 COM @Afg,@Analyzer,Secure_code$
1160 INTEGER Lower_8,Benign_chn1
1170 !
1180 Benign_chn1=1
1190 Lower_8=BINAND(Delay_dac,255)
1200 !
1210 OUTPUT @Afg;"DIAG:POKE #HE0000B,8,2"
1220 OUTPUT @Afg;"DIAG:POKE #HE0000D,8,"&VAL$(Lower_8)
1230 OUTPUT @Afg;"DIAG:POKE #HE0000B,8,7"
1240 OUTPUT @Afg;"DIAG:POKE #HE0000D,8,"&VAL$(Benign_chn1+7)
1250 WAIT .1
1260 SUBEND
1270 !
```

(Continued on next page)

Skew DAC Adjustment Procedure (cont'd)

Example Program (cont'd)

```
1280 Wrt_skew_con:SUB Wrt_skew_con(INTEGER Cal_word)
1290  COM @Afg,@Analyzer,Secure_code$
1300  DIM Id$[50]
1310  !
1320  !Check firmware rev
1330  OUTPUT @Afg;"*IDN?"
1340  ENTER @Afg;Id$
1350  !
1360  IF POS(Id$,"A.01.00") THEN
1370    PRINT "This rev does not support skew DAC calibration."
1380    CALL Abort_error
1390  END IF
1400  !
1410  STATUS @Afg,3;Address           !Get path address
1420  !
1430  OUTPUT @Afg;"CAL:SEC:STAT OFF,"&Secure_code$
1440  ASSIGN @Afg TO Address;FORMAT OFF
1450  OUTPUT @Afg USING "#,K";"CAL:DATA:SKEW #0"
1460  OUTPUT @Afg;Cal_word
1470  OUTPUT @Afg USING "#,K";CHR$(10),END
1480  ASSIGN @Afg TO Address
1490  OUTPUT @Afg;"CAL:SEC:STAT ON"
1500  !
1510  PRINT "Skew constant written to AFG."
1520 SUBEND
1530 !
1540 Setup_spec:SUB Setup_spec(Amp_in_dbm$,Center$,Span$)
1550  COM @Afg,@Analyzer,Secure_code$
1560  OUTPUT @Analyzer;"IP;RB 100HZ;VB 100HZ"       !Preset, set res & vid BW
1570  OUTPUT @Analyzer;"RL "&Amp_in_dbm$          !Set ref level
1580  OUTPUT @Analyzer;"SP "&Span$&"HZ"           !Set freq span
1590  OUTPUT @Analyzer;"CF "&Center$              !Set center frequency
1600 SUBEND
1610 !
1620 Get_2nd_harm:SUB Get_2nd_harm(Test_span$)
1630  COM @Afg,@Analyzer,Secure_code$
1640  OUTPUT @Analyzer;"S2;TS;E1"                   !Peak search
1650  OUTPUT @Analyzer;"MKCF"                       !Center freq to marker
1660  OUTPUT @Analyzer;"SP "&Test_span$&"HZ"      !Narrow span
1670 SUBEND
1680 !
```

(Continued on next page)

Skew DAC Adjustment Procedure (cont'd)

Example Program (cont'd)

```
1690 Meas_2nd_harm:SUB Meas_2nd_harm(Reading)
1700  COM @Afg,@Analyzer,Secure_code$
1710  OUTPUT @Analyzer;"TS;E1"           !Find peak
1720  OUTPUT @Analyzer;"MA"           !Measure amplitude
1730  ENTER @Analyzer;Reading
1740  SUBEND
1750  !
1760 Read_skew_con:SUB Read_skew_con(INTEGER Skew_cal_con)
1770  COM @Afg,@Analyzer,Secure_code$
1780  ALLOCATE Id$[50]
1790  !
1800  OUTPUT @Afg;"*IDN?"
1810  ENTER @Afg;Id$
1820  IF POS(Id$,"A.01.00") THEN
1830    Skew_cal_con=128
1840    SUBEXIT
1850  END IF
1860  !
1870  STATUS @Afg,3;Address
1880  !
1890  OUTPUT @Afg;"CAL:SEC:STAT OFF,"&Secure_code$
1900  OUTPUT @Afg;"CAL:DATA:SKEW?"
1910  ASSIGN @Afg TO Address;FORMAT OFF
1920  ENTER @Afg USING "3A,1(W)";Dummy$[1,3],Skew_cal_con
1930  ASSIGN @Afg TO Address
1940  OUTPUT @Afg;"CAL:SEC:STAT ON"
1950  SUBEND
```

Chapter 4

Replaceable Parts

Introduction

This chapter contains information for ordering replaceable parts for the HP E1445A AFG.

Exchange Assemblies

Table 4-1 lists assemblies that may be replaced on an exchange basis (NEW/EXCHANGE ASSEMBLIES). Exchange assemblies are available only on a trade-in basis. Defective assemblies must be returned for credit. Assemblies required for spare parts stock must be ordered by the new assembly part number.

Ordering Information

To order a part listed in Table 4-1, specify the Hewlett-Packard part number and the quantity required. Send the order to your nearest Hewlett-Packard Sales and Support Office.

Replaceable Parts List

Table 4-1 lists the user-replaceable parts for the HP E1445A AFG. See Figure 4-1 for locations of user-replaceable parts. Table 4-2 lists the reference designators for the AFG. Table 4-3 is the code list of manufacturers.

Table 4-1. HP E1445A Replaceable Parts

Reference Designator	HP Part Number	Qty	Part Description	Mfr. Code	Mfr. Part Number
			NEW/EXCHANGE ASSEMBLIES		
	ME1445A	1	E1445A (NEW)	28480	ME1445A
	E1445-66201	1	E1445A (EXCHANGE)	28480	E1445-66201
			MECHANICAL PARTS		
HDL1	E1400-45102*	1	HANDLE-BOTTOM METAL INJECTION MOLDING	28480	E1400-45102*
HDL2	E1400-45101*	1	HANDLE-TOP METAL INJECTION MOLDING	28480	E1400-45101*
HDW010	0380-1858	2	STANDOFF-HEX .312-IN-LG 4-40-THD	05791	ST9532-36
HDW011	2190-0004	2	WASHER-LK INTL T NO. 4 .115-IN-ID	78189	SF 1904-00
HDW11-HDW15	2950-0054	5	NUT-HEX-DBL-CHAM 1/2-28-THD .125-IN-THK	28480	2950-0054
HDW17-HDW21	3050-0604	5	WASHER- 7/16 IN .5-IN-ID .75-IN-OD	86928	5710-94-16
MP1	8160-0686	1	CLIP-RFI STRIP-FINGERS BE-CU SN-PL	30817	00786-185
MP2-MP5	E1450-01202	4	EMI STRIP	28480	E1400-01202
PNL1	E1445-00202*	1	FRONT PANEL	28480	E1445-00202*
SCR1-SCR8	0515-1135	9	SCREW- MACHINE M3 X 0.5 25MM-LG -HD	28480	0515-1135
SCR10	0515-1135	1	SCREW- MACHINE M3 X 0.5 25MM-LG -HD	28480	0515-1135
SCR13-SCR14	E1400-00610*	2	SHOULDER SCREW ASSEMBLY	28480	E1400-00610*
SCR17	0515-0430	1	SCREW- MACHINE M3 X 0.5 6MM-LG PAN-HD	28480	0515-0430
SHD1	E1445-00601	1	TOP SHIELD	28480	E1445-00601
SHD2	E1445-00602*	1	BOTTOM SHIELD	28480	E1445-00602*
SHD3	E1445-00603	1	FLEX SHIELD	28480	E1445-00603
			A1 PRINTED CIRCUIT ASSEMBLY		
A1	E1445-63501	1	PCA- DAC MAIN	28480	E1445-63501
CR610-CR613	1990-1448	5	LED-LAMP ARRAY LUM-INT=1.5MCD, GREEN LENS	72619	553-0302
CR614	1990-1364	1	LED-LAMP ARRAY LUM-INT=300UCD, RED-GREEN LENS	72619	553-0321
CR615	1990-1448	1	LED-LAMP ARRAY LUM-INT=1.5MCD, GREEN LENS	72619	553-0302
CR616	1990-1507	1	LED-LAMP LUM-INT=800UCD IF=20MA-MAX, RED LENS	72619	553-0301
F301-F305	2110-0699	5	FUSE-SUBMINIATURE 5A 125V NTD AX UL CSA	75915	R251005T1
J2-J3	1251-5150	2	CONNECTOR-POST TYPE .100-PIN-SPCG 12-CONTACT	18873	67996-612
J101-J104	1252-4568	5	CONNECTOR-POST TYPE .100-PIN-SPCG 3-CONTACT	18873	89602-603
J105	1252-1201	1	CONNECTOR-RECT D-SUBMINIATURE 25-CONTACT	00779	748877-1
J106	1252-4568	1	CONNECTOR-POST TYPE .100-PIN-SPCG 3-CONTACT	18873	89602-603
J110-J113	1250-2012	4	CONNECTOR-RF BNC FEM PC-W-STDFS 50-OHM	00779	227676-1
JM1-JM7	1258-0209	7	JUMPER-REMOVABLE 2 POSITION; .250 IN	00779	531220-2
SP301-SP302	3101-2243	2	SWITCH-DIP ROCKER 8-1A 0.05A 30VDC	81073	76YY22318S
			A2 PRINTED CIRCUIT ASSEMBLY		
A2	E1445-63502	1	PCA- DAC ANALOG	28480	E1445-63502
J901	1250-2012	1	CONNECTOR-RF BNC FEM PC-W-STDFS 50-OHM	00779	227676-1
			A3 PRINTED CIRCUIT ASSEMBLY		
A3	E1445-63503	1	PCA- DIG TIMER	28480	E1445-63503
U501	1813-0879	1	CLOCK-OSCILLATOR-XTAL 40.0-MHZ 0.005%	28480	1813-0879
U502	1813-0831	1	CLOCK-OSCILLATOR-XTAL 42.949672-MHZ	28480	1813-0831

* These parts are not compatible with older versions of the E1445A that have plastic handles. To replace one of these parts on an older E1445A, you must order all five of the parts marked with a *.

Table 4-2. HP E1445A Reference Designators

HP E1445A Reference Designators			
A	assembly	MP	mechanical part
CR	diode	PNL	panel
HDL	handle	SCR	screw
HDW	hardware	SHD	shield
J	electrical connector (jack)	SP	switch
JM	jumper	U	integrated circuit
F	fuse		

Table 4-3. HP E1445A Code List of Manufacturers

Mfr. Code	Manufacturer's Name	Manufacturer's Address	Zip Code
00779	AMP INC	HARRISBURG, PA US	17111
05791	LYN-TRON INC	BURBANK, CA US	91505
18873	DUPONT E.I. DE NUMOURS & CO	WILMINGTON, DE US	19801
28480	HEWLETT PACKARD COMPANY - CORPORATE	PALO ALTO, CA US	94304
30817	INSTRUMENT SPECIALTIES INC	DEL WATER GAP, PA US	18327
72619	DIALIGHT CORP	BROOKLYN, NY US	11237
75915	LITTELFUSE INC	DES PLAINES, IL US	60016
78189	ILLINOIS TOOL WORKS INC	ELGIN, IL US	60126
81073	SHAKEPROOF		
83486	GRAYHILL INC	LA GRANGE, IL US	60525
86928	ELCO INDUSTRIES INC	ROCKFORD, IL US	61125
	SEASTROM MFG CO	GLENDALE, CA US	91201

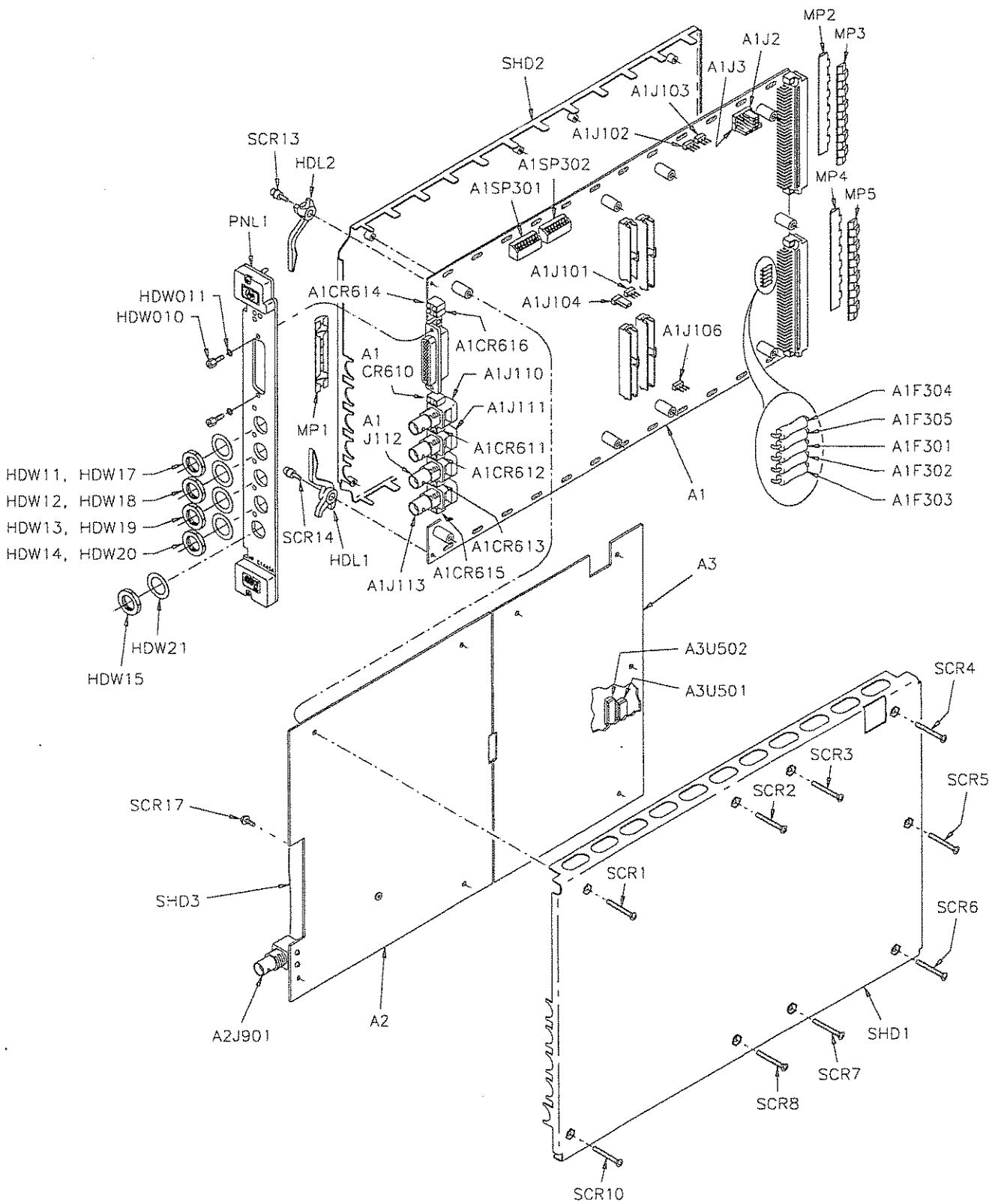

Figure 4-1. HP E1445A Replaceable Parts

Chapter 5

Service

Introduction

This chapter contains service information for the HP E1445A AFG, including troubleshooting guidelines and repair/maintenance guidelines.

WARNING

Do not perform any of the service procedures shown unless you are a qualified, service-trained technician, and have read the WARNINGS and CAUTIONS in Chapter 1.

Equipment Required

Equipment required for AFG troubleshooting and repair is listed in Table 1-1, *Recommended Test Equipment*. Any equipment that satisfies the requirements given in the table may be substituted. To avoid damage to the screw head slots, use T8 and T10 Torx drivers as described in the disassembly instructions later in this chapter.

Service Aids

See Chapter 4 for descriptions and locations of HP E1445A replaceable parts. Service notes, manual updates, and service literature for the AFG may be available through Hewlett-Packard. For information, contact your nearest Hewlett-Packard Sales and Support Office.

Troubleshooting Techniques

To troubleshoot an HP E1445A problem, you should first identify the problem, and then isolate the cause to a user-replaceable part.

Identifying the Problem

AFG problems can be divided into three general categories:

- Operator errors
- Catastrophic failures
- Performance out of specification

Operator Errors

Apparent failures may result from operator errors. See Appendix B in the *HP E1445A User's Manual* for information on operator errors.

Catastrophic Failure

If a catastrophic failure occurs, see "Testing the Assembly" to troubleshoot the AFG.

Performance Out of Specification

If the AFG fails any of its Performance Tests, perform the adjustments described in Chapter 3, then repeat the Performance Tests.

Testing the Assembly

You can use the tests and checks in Table 5-1 to isolate the problem. See Figure 4-1 in Chapter 4 for locations of user-replaceable parts.

Table 5-1. HP E1445A Tests/Checks

Test/Check	Reference Designator	Check:
Heat Damage	-----	Discolored PC boards Damaged insulation Evidence of arcing
AFG/Jumper Settings	A1BG0 - A1BG3 A1SP301 A1SP302	Bus Request level setting LADDR setting Servant Area setting
AFG PCAs	A1F301 - A1F305	Fuse continuity Damaged connectors

Checking for Heat Damage

Inspect the AFG for signs of abnormal internally generated heat such as discolored printed circuit boards or components, damaged insulation, or evidence of arcing. If there is damage, do not operate the AFG until you have corrected the problem.

Checking Switches/Jumpers

Verify that the logical address setting is set correctly (factory set at 80). Verify that the bus request level and servant area settings are correct. See the *HP E1445A User's Manual* for information.

Checking the AFG PCAs

Check fuse continuity and inspect all connectors for bent pins or damaged contacts.

Disassembly

Use the following procedure to disassemble the AFG (see Figure 5-1):

1. Remove the nine T10 Torx screws on the right side panel.
2. Remove the front panel handles using a T-8 TORX driver.
3. Remove the hex standoffs and washers from the front panel digital port connector.
4. Remove the nuts and washers from the front panel BNC's.

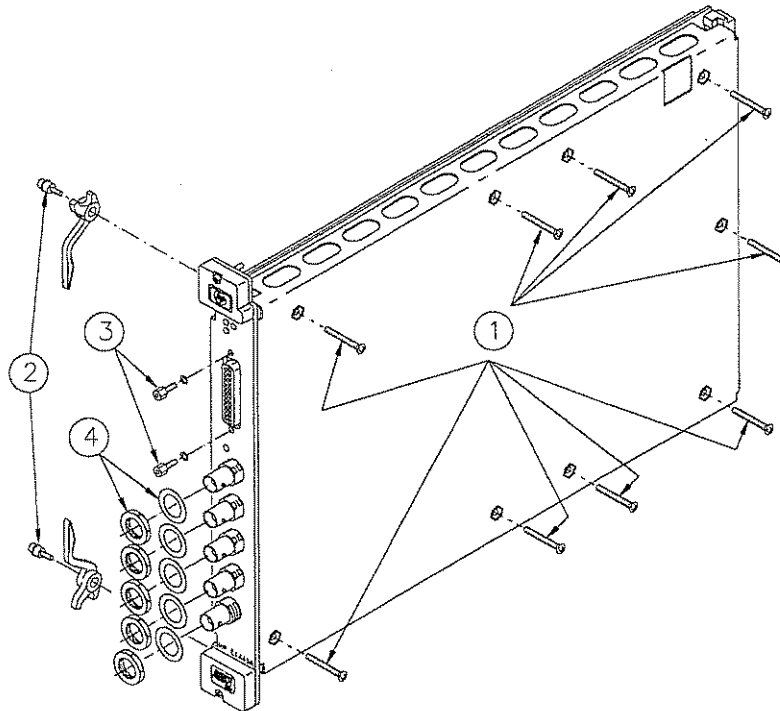

Figure 5-1. HP E1445A Disassembly

Removing BNC Connectors

Use the following steps to remove the AFG front panel BNC connectors (refer to Figure 5-2):

1. Unsolder wires
2. Remove the two T8 torx screws
3. Remove the BNC connector
4. Reverse the order to reinstall the connector

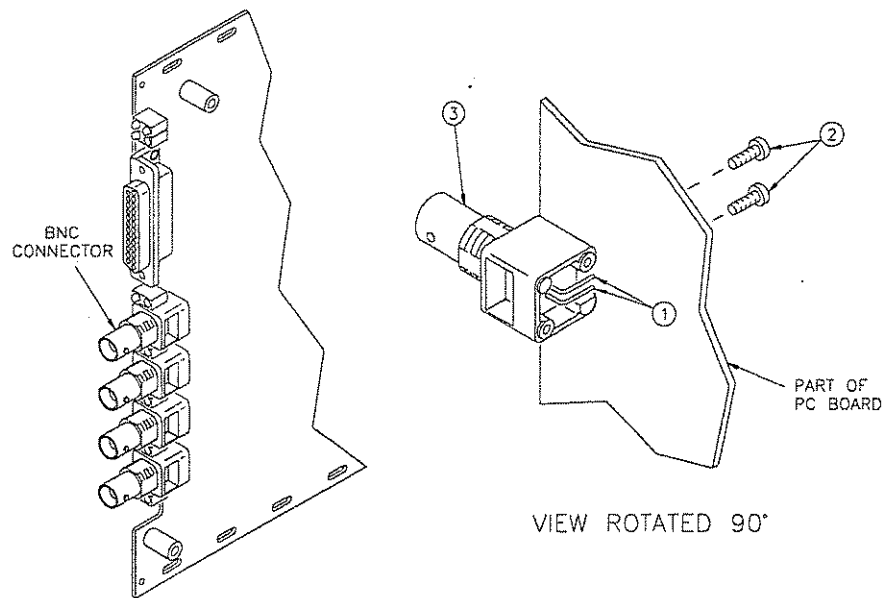

Figure 5-2. Removal of BNC Connectors

Repair/ Maintenance Guidelines

This section provides guidelines for repairing and maintaining the HP E1445A AFG, including:

- ESD precautions
- Soldering printed circuit boards
- Post-repair safety checks

ESD Precautions

Electrostatic discharge (ESD) may damage static sensitive devices in the HP E1445A AFG. This damage can range from slight parameter degradation to catastrophic failure. When handling AFG assemblies, follow these guidelines to avoid damaging AFG components:

- Always use a static-free work station with a pad of conductive rubber or similar material when handling AFG components.
- If a device requires soldering, be sure the assembly is placed on a pad of conductive material. Also, be sure that you, the pad, and the soldering iron tip are grounded to the assembly.

Soldering Printed Circuit Boards

When soldering to any circuit board, keep in mind the following guidelines:

- Avoid unnecessary component unsoldering and soldering. Excessive replacement can result in damage to the circuit board and/or adjacent components.
- Do not use a high power soldering iron on etched circuit boards, as excessive heat may lift a conductor or damage the board.
- Use a suction device or wooden toothpick to remove solder from component mounting holes. When using a suction device, be sure that the equipment is properly grounded.

Post-Repair Safety Checks

After making repairs to the HP E1445A AFG, inspect the AFG for any signs of abnormal internally generated heat, such as discolored printed circuit boards or components, damaged insulation, or evidence of arcing. Determine and correct the cause of the condition. Then perform the Self-Test described in Chapter 2 to verify that the AFG is functional.

HP
E
1
4
4
5
A
S
E
R
V
I
C
E
M
A
N
U
A
L