

EPM-P Series Peak and Average Power Meters



User's Guide



Agilent Technologies

General

Information contained in this document is subject to change without notice. Agilent Technologies makes no warranty of any kind with regard to this material, including, but not limited to, the implied warranties of merchantability and fitness for a particular purpose. Agilent Technologies shall not be liable for errors contained herein or for incidental or consequential damages in connection with the furnishings, performance, or use of this material. No part of this document may be photocopied, reproduced, or translated to another language without the prior written consent of Agilent Technologies.

Copyright 2000, 2001 Agilent Technologies

Station Road, South Queensferry, Scotland,
EH30 9TG, UK.

Agilent Part No. E4416-90023

Printed in UK

June 2001

Legal Information

Certification

Agilent Technologies certifies that this product met its published specifications at the time of shipment from the factory. Agilent Technologies further certifies that its calibration measurements are traceable to the United States National Institute of Standards and Technology, to the extent allowed by the Institute's calibration facility, and to the calibration facilities of other International Standards Organization members.

Warranty

This Agilent Technologies instrument product is warranted against defects in material and workmanship for a period of three years from date of shipment. During the warranty period, Agilent Technologies will at its option, either repair or replace products which prove to be defective. For warranty service or repair, this product must be returned to a service facility designated by Agilent Technologies. Buyer shall prepay shipping charges to Agilent Technologies and Agilent Technologies shall pay shipping charges, duties, and taxes for products returned to Agilent Technologies from another country. Agilent Technologies warrants that its software and firmware designated by Agilent Technologies for use with an instrument will execute its programming instructions when properly installed on that instrument. Agilent Technologies does not warrant that the operation of the instrument, or firmware will be uninterrupted or error free.

Limitation of Warranty





The foregoing warranty shall not apply to defects resulting from improper or inadequate maintenance by Buyer, Buyer-supplied software or interfacing, unauthorized modification or misuse, operation outside of the environmental specifications for the product, or improper site preparation or maintenance. NO OTHER WARRANTY IS EXPRESSED OR IMPLIED. AGILENT TECHNOLOGIES SPECIFICALLY DISCLAIMS THE IMPLIED WARRANTIES OF MERCHANTABILITY AND FITNESS FOR A PARTICULAR PURPOSE.

Exclusive Remedies

THE REMEDIES PROVIDED HEREIN ARE BUYER'S SOLE AND EXCLUSIVE REMEDIES. AGILENT TECHNOLOGIES SHALL NOT BE LIABLE FOR ANY DIRECT, INDIRECT, SPECIAL, INCIDENTAL, OR CONSEQUENTIAL DAMAGES, WHETHER BASED ON CONTRACT, TORT, OR ANY OTHER LEGAL THEORY.

Safety Symbols

The following symbols on the instrument and in the documentation indicate precautions which must be taken to maintain safe operation of the instrument.

	The Instruction Documentation Symbol. The product is marked with this symbol when it is necessary for the user to refer to the instructions in the supplied documentation.
	Alternating current (AC)
	This symbol indicates the operating switch for 'On' mode.
	This symbol indicates the operating switch for 'Stand-by' mode. Note, the instrument is NOT isolated from the mains when the switch is pressed. To isolate the instrument, the mains coupler (mains input cord) should be removed from the power supply.

Safety Notices This guide uses warnings and cautions to denote hazards

WARNING

A warning calls attention to a procedure, practice or the like, which, if not correctly performed or adhered to, could result in injury or loss of life. Do not proceed beyond a warning until the indicated conditions are fully understood and met.

CAUTION

A caution calls attention to a procedure, practice or the like which, if not correctly performed or adhered to, could result in damage to or the destruction of part or all of the equipment. Do not proceed beyond a caution until the indicated conditions are fully understood and met.

General Safety Information

The following general safety precautions must be observed during all phases of operation, service, and repair of this instrument. Failure to comply with these precautions or with specific warnings elsewhere in this manual violates safety standards of design, manufacture, and intended use of the instrument. Agilent Technologies assumes no liability for the customer's failure to comply with these requirements.

WARNING

This is a Safety Class I instrument (provided with a protective earthing ground, incorporated in the power cord). The mains plug shall only be inserted in a socket outlet provided with a protective earth contact. Any interruption of the protective conductor inside or outside of the instrument is likely to make the instrument dangerous. Intentional interruption is prohibited.

DO NOT operate the product in an explosive atmosphere or in the presence of flammable gasses or fumes.

DO NOT use repaired fuses or short-circuited fuseholders: For continued protection against fire, replace the line fuse(s) only with fuse(s) of the same voltage and current rating and type.

DO NOT perform procedures involving cover or shield removal unless you are qualified to do so: Operating personnel must not remove equipment covers or shields. Procedures involving the removal of covers and shields are for use by service-trained personnel only.

DO NOT service or adjust alone: Under certain conditions, dangerous voltages may exist even with the equipment switched off. To avoid dangerous electrical shock, service personnel must not attempt internal service or adjustment unless another person, capable of rendering first aid and resuscitation, is present.

DO NOT operate damaged equipment: Whenever it is possible that the safety protection features built into this product have been impaired, either through physical damage, excessive moisture, or any other reason, **REMOVE POWER** and do not use the product until safe operation can be verified by service-trained personnel. If necessary, return the product to a Agilent Sales and Service Office for service and repair to ensure the safety features are maintained.

DO NOT substitute parts or modify equipment: Because of the danger of introducing additional hazards, do not install substitute parts or perform any unauthorized modification to the product. Return the product to a Hewlett-Packard Sales and Service Office for service and repair to ensure the safety features are maintained.

Welcome

Welcome to the EPM-P series power meter *User's Guide!*

Together with the E-series E9320 power sensors, the EPM-P series power meters can measure complex modulation formats such as TDMA, CDMA and W-CDMA. Pre-installed measurement setups for GSM900, EDGE, NADC, iDEN, Bluetooth, cdmaOne, W-CDMA, and cdma2000 help reduce the time required to measure these common wireless communications formats.

Power measurements include peak, peak-to-average ratio and average power of RF and microwave signals. Extensive triggering features such as continuous, level, external TTL, and GPIB, are available for making time gated measurements.

In addition, the EPM-P power meters are compatible with E-series E9300, E-series 4410, and 8480 series power sensors giving you additional choice for conventional, average power measurements.

Documentation Information

As shown in the *Installation Guide*, this guide is only part of the information supplied. The documentation consists of:

- The *Installation Guide* - Shows you how to check your power meter, switch it on and connect it to an Agilent power sensor. This information is presented in English, French, German, Italian, Japanese, and Spanish languages.
- The *User's Guide* - This book, shows you how to operate your power meter from the front panel interface to make measurements using the Agilent E-series E9320, E-series E9300, E-series E4400, and 8480 series power sensors. You can find the *User's Guide* as Adobe Acrobat PDF (Portable Document Format) files on the supplied CD-ROM in English, French, German, Italian, Japanese, and Spanish languages.
- The *Programmer's Guide* - Shows you how to operate your power meter using the remote interfaces. You can find the *Programmer's Guide* as an Adobe Acrobat PDF file on the supplied CD-ROM in English language only.

Printed Guides are available by ordering the following options:

- English language - Option OBK
- French language - Option ABF
- German language - Option ABD
- Italian language - Option ABZ
- Japanese language - Option ABJ
- Spanish language - Option ABE

NOTE The *Programmer's Guide* is supplied in English Language only.

What You'll Find in this Guide

This *User's Guide* shows you how to operate your EPM-P series power meter using the front panel interface to make measurements with the E-series E9320, E-series E9300, E-series 4410, and 8480 series power sensors.

Some EPM-P series power meter features and capabilities depend on the type of power sensor connected. Other features are general and independent of the power sensor. This *User's Guide* is therefor divided into 3 main blocks.

- Chapters 1 and 2 show you the main EPM-P power meter functions. These functions are typically independent of the connected sensor type.
- Chapters 3, 4, 5, and 6 show you how to use the EPM-P power meters with each of the four sensor families.
- Chapters 7 and 8 describe general maintenance and specifications.

For remote programming information, refer to the EPM-P series power meters *Programmer's Guide*.

Contents

1. Introduction	19
<hr/>	
Power Meter and Sensor Capability	20
Specifications	20
Conventions Used in this Guide	21
Front Panel Keys and Connections	22
The Display Layout	26
Window Symbols	34
Warning Symbol	34
Confirmation Pop-up	34
Wait Symbol	35
1 of Many Entry Pop-up	35
Configuration Conflict Pop-up	35
Numeric or Alphanumeric Entry Pop-up	35
2. General Power Meter Functions	37
<hr/>	
Zeroing and Calibrating	38
Zeroing	38
Calibration	38
Calibration with E-Series Power Sensors	40
Calibration with 8480 Series Power Sensors	41
Zero/Cal Lockout	45
Zeroing and Calibrating Using TTL Inputs	46
Setting the Units of Measurement	49
Selecting Units of Measurement from the Softkeys	50
Setting the Resolution	51
Making Relative Measurements	52
Setting Offsets	53
Setting Channel Offsets	53
Setting Display Offsets	55
Setting Frequency Dependent Offsets	57
Setting Averaging	64
Step Detection	66
Setting Measurement Limits	67
Setting Limits	68
Checking for Limit Failures	72

Setting the Range	73
Scaling the Analog Display	74
Recorder Output	76
Saving and Recalling Power Meter Configurations	79
Measuring Pulsed Signals	82
Presetting the Power Meter	85
Preset Conditions	85

3. Using E-Series E9320 Power Sensors 89

Introduction	90
Power Meter Configuration	92
Default Channel Setup	92
Measurement Method	93
Measurement Display	94
Configuring a Peak Power Measurement	96
The Set Up Process	97
Setting Up Using Data Entry	97
Setting Up Using Trace Markers	116
Measurement Example	123
Using Pre-installed Measurement Setups	128
Measuring GSM	129
Measuring EDGE	133
Measuring NADC	137
Measuring iDEN	142
Measuring Bluetooth	145
Measuring cdmaOne	149
Measuring W-CDMA	152
Measuring cdma2000	155

4. Using E-Series E9300 Power Sensors 159

Introduction	160
Power Meter Configuration	161
Default Channel Setup	162
Measurement Accuracy	163
Measuring Spread Spectrum and Multitone Signals	165
CDMA Signal Measurements	166
Multitone Signal Measurements	167
Measuring TDMA Signals	168
Power Meter and Sensor Operation	168
Achieving Stable Results with TDMA Signals	168

Achieving Stable Results with GSM Signals	169
Electromagnetic Compatibility (EMC) Measurements	170
Measurement Accuracy and Speed	171
Setting the Range	171
Measurement Considerations	172
5. Using E-Series 4410 Power Sensors	175
<hr/>	
Introduction	176
Power Meter Configuration	177
Default Channel Setup	178
Measurement Accuracy	179
6. Using 8480 Series Power Sensors	181
<hr/>	
Introduction	182
Power Meter Configuration	183
Default Channel Setup	183
Measurement Accuracy	185
Frequency Specific Calibration Factors	186
Sensor Calibration Tables	192
Editing/Generating Sensor Calibration Tables	196
Pre-installed Calibration Table Contents	200
7. Maintenance	203
<hr/>	
Self Test	204
Power On Self Test	204
Front Panel Selection of Self Tests	205
Remote Testing	207
Test Descriptions	208
Error Messages	211
Introduction	211
Error Message List	213
Operator Maintenance	224
Replacing the Power Line Fuse	224
Contacting Agilent Technologies	226
Before calling Agilent Technologies	226
Check the Basics	226
Instrument serial numbers	227
Sales and Service Offices	229
Returning Your Power Meter for Service	230

8. Specifications and Characteristics 233

Introduction 234
Power Meter Specifications 235
Measurement Characteristics 240
 Physical Specifications 243
Environmental Specifications 244
 Operating Environment 244
 Storage Conditions 244
Regulatory Information 245
 Electromagnetic Compatibility 245
 Product Safety 245
 Physical Specifications 246

Index

Figures

Figure 1	Reference Calibration Factor Pop Up Window	41
Figure 2	Rmt I/O Port TTL Inputs	46
Figure 3	Rel Indicator	52
Figure 4	Simplified Measurement Path	53
Figure 5	Offset applied.	54
Figure 6	Offset Pop-up	55
Figure 7	Offset applied.	56
Figure 8	Offset Tables	58
Figure 9	Frequency Dependent Offset Table selected.	59
Figure 10	Frequency Dependent Offset Configured	60
Figure 11	“Edit Offset” Screen with some data added.	62
Figure 12	Averaged Readings	64
Figure 13	Filter Length Pop-up	65
Figure 14	Limits Checking Application.	67
Figure 15	Limits Checking Results	68
Figure 16	Setting Maximum Limit	69
Figure 17	Remote I/O TTL Outputs	70
Figure 18	TTL Output Pop-up	71
Figure 19	Example of TTL Disconnect Warning Message.	71
Figure 20	TTL Limits Pop-up.	71
Figure 21	Limit Failures.	72
Figure 22	Channel Setup - Range	73
Figure 23	Analog display in lower window	74
Figure 24	Meter Maximum Pop-up	74
Figure 25	Meter Minimum Pop-up	75
Figure 26	Recorder Maximum Pop-up	77
Figure 27	Recorder Minimum Pop-up	77
Figure 28	Save/Recall screen	79
Figure 29	“Save” Pop-up	80
Figure 30	“Recall” Pop-up	81
Figure 31	Pulsed Signal	82
Figure 32	Duty Cycle: Off	83
Figure 33	Duty Cycle Pop-Up	83
Figure 34	Duty Cycle: On, 50%	84
Figure 35	E-series E9320 power sensor default Channel Setup	92
Figure 36	Measurement Gates	93
Figure 37	Twelve Measurements per Channel	94

Figure 38	E-series E9320 power sensor default Channel Setup . . .	98
Figure 39	Bandwidth Filter Shapes	100
Figure 40	Gates screen	102
Figure 41	Time Gating Start pop-up	102
Figure 42	Time Gating Length pop-up	103
Figure 43	Trigger menu - Free Run Mode	104
Figure 44	Trigger Setting Menu 1 of 2	105
Figure 45	Trigger Level Pop-up	106
Figure 46	Trigger Delay Pop-up	107
Figure 47	Trigger Setting Menu 2 of 2	107
Figure 48	Trigger Hold off Pop-up	108
Figure 49	Trigger Hysteresis Pop-up	109
Figure 50	Display Type Menu	110
Figure 51	Lower Window/Lower Measurement Setup	111
Figure 52	Measurement set-up example	112
Figure 53	Measurement example display	112
Figure 54	Analog display in lower window	113
Figure 55	Meter Maximum Pop-up	113
Figure 56	Meter Minimum Pop-up	114
Figure 57	Trace display in lower window	115
Figure 58	Trace Maximum Pop-up	115
Figure 59	Gate Control Menu and Display	116
Figure 60	E-series E9320 power sensor default Channel Setup . . .	117
Figure 61	Trigger menu - Free Run Mode	118
Figure 62	Gate Control Menu and Display	119
Figure 63	Trigger Marker - Negative Delay	120
Figure 64	Trace Control Display	121
Figure 65	Bluetooth Signal with Markers Shown	122
Figure 66	Measurement Example Measurement Display	127
Figure 67	Preset Selection Display	128
Figure 68	GSM Measurement Display	129
Figure 69	EDGE Measurement Display	133
Figure 70	Full Rate Frame	137
Figure 71	NADC Measurement Display	138
Figure 72	Bluetooth Measurement Display	145
Figure 73	Markers on a Bluetooth Measurement	148
Figure 74	cdmaOne Measurement Display	149
Figure 75	W-CDMA Measurement Display	152
Figure 76	typical cdma2000 Measurement Display	155
Figure 77	E-series E9300 Auto-averaging Settings	161
Figure 78	E-series E9300 sensor default Channel Setup	162
Figure 79	Frequency Pop Up Window	164
Figure 80	Spread Spectrum Signal	165

Figure 81	Wideband CDMA Error of E-series E9300 power sensor versus corrected CW sensor	166
Figure 82	CDMA (IS-95A): 9Ch Fwd.	166
Figure 83	Calibration Factors versus Frequency	167
Figure 84	E-series CW sensor Auto-averaging settings	177
Figure 85	E-series CW sensor default Channel Setup	178
Figure 86	Frequency Pop Up Window	180
Figure 87	8480 Series Auto-averaging Settings.	183
Figure 88	8480 series sensor default Channel Setup	184
Figure 89	Reference Calibration Factor Pop Up Window	187
Figure 90	Calibration Factor Pop Up Window	188
Figure 91	Calibration Factor Displayed.	189
Figure 92	Sensor Table Selected.	193
Figure 93	Frequency Pop Up Window	194
Figure 94	Frequency/Calibration Table Display	195
Figure 95	“Sensor Tbls” Screen.	197
Figure 96	“Edit Cal” Screen.	197
Figure 97	Self Test in Progress	206
Figure 98	Error Indicator Position	211
Figure 99	Error Queue Message	212
Figure 100	Replacing the Fuse	225
Figure 101	Video Bandwidth vs. Peak Power Dynamic Range.	237

Tables

Table 1	Power Sensor Connection Requirements	43
Table 2	TTL Input Control Logic	46
Table 3	TTL Inputs Timing Diagram 1	47
Table 4	TTL Inputs Timing Diagram 2	48
Table 5	Measurement Units - Single Channel Meters	49
Table 6	Measurement Units - Dual Channel Meters	49
Table 7	Range of Values for Window Limits	68
Table 8	Sensor Bandwidth	90
Table 9	Measurement Example Channel Setup	123
Table 10	Measurement Example Gate Configurations	124
Table 11	Measurement Example Trigger Configurations	125
Table 12	Trace Setup Parameters	127
Table 13	GSM900 Configurations	130
Table 14	EDGE Configurations	134
Table 15	NADC Configurations	139
Table 16	iDEN Configurations	143
Table 17	Bluetooth Configurations	146
Table 18	cdmaOne Configurations	150
Table 19	W-CDMA Configurations	153
Table 20	cdma2000 Configurations	156
Table 21	Power Sensor Connection Requirements	163
Table 22	8480 Series Connection Requirements	189
Table 23	Installed Power Sensor Models	196



1 Introduction

What You'll Find In This Chapter

This Chapter introduces you to the front panel and display of the EPM-P series power meters.

It contains these sections:

- Power Meter and Sensor Capability on page 20
 - Conventions Used in this Guide on page 21
 - Front Panel Keys and Connections on page 22
 - The Display Layout on page 26
 - Window Symbols on page 34
-

Power Meter and Sensor Capability

Your E4416A or E4417A power meter is compatible with E-series E9320, E-series E9300, E-series E4400, and 8480 series power sensors. However, not all sensor and meter combinations have the same features or capabilities. The main differences are:

Features	E-Series E9320	E-Series E9300	E-Series E4400	8480 Series
Average Power of CW Signal	•	•	•	•
Cal Factors on EEPROM	•	•	•	
> 200 Readings/sec.	•	•	•	
Average Power of modulated signal	•	•		
Peak/Burst Average Power	•			
Time Gated Measurements	•			

NOTE The E-series E9320 power sensors require E9288 series cables for connection to the EPM-P power meters. The E9288 series cables are color coded to distinguish them for the 11730 series cables.

Specifications

The specifications for the power meter are listed in Chapter 8.

Conventions Used in this Guide

The following conventions are used throughout this guide.



This symbol and text represents a labeled key on the power meter front panel.

Softkey

This symbol and text represents a labeled softkey and is used to indicate you should press the unmarked key beside the displayed text.

Message

This symbol and text represents a displayed message.

Parameter

This is used to represent a parameter, value, or title.

“Channel”

This User’s Guide describes the operation for both the single channel E4416A and the dual channel E4417A. To identify channels on a dual channel meter a **Channel** softkey on an E4416A meter becomes **Channel A** and **Channel B** on E4417A.

When you are asked to press “the channel” **Softkey** in a procedure, make sure you select the relevant channel.

Front Panel Keys and Connections

This section briefly describes the functions of the front panel keys and connectors. The *User's Guide* shows you how to use them in more detail.



These keys are located to the left of the display.

Key

Function



Press this key to switch the meter between on and standby. When power is supplied, the orange LED above the key is lit. Press the key to switch the meter on. The green LED lights.



Press this key to select the upper or lower measurement window. The selected window is highlighted by a shadowed box. Any measurement setup you create is implemented in the selected window.







Press this key to choose windowed, expanded, or full-screen display of a numeric measurement. It also provides quick access to the Gate Control screen and menu when a trace window is selected.



Press this key to preset the power-meter when it is operating in local mode (front panel operation) or to select a pre-installed measurement configuration. A pop-up-window is displayed asking you to confirm the command. It also enables you to take control of the meter from the front panel when operating via the remote interfaces (when Local Lock Out is not enabled).











These keys are located along the lower edge of the display.

Key	Function
	Press this key to access general configuration-menus, such as GPIB address. You can also access some measurement configuration-menus. The measurement screen remains visible.
	Press this key to access the channel configuration tables and menus. Channel parameters such as averaging and offsets are configured from this menu.
	Press this key to access the triggering menu. Unless an E-series E9320A sensor is connected, all the menu keys are disabled (greyed out).
	Press this key to setup relative measurements or set display offsets.
	Press this key to access the measurement display menu. You can choose the displayed measurement resolution, units and display format.



These keys are all associated with the menu labels and data entry. They are located to the right of the display.

Key	Function
	<p>Press this key to access the next pages of a menu. For example, 1 of 2 displayed beside the  key indicates page one of a two page menu is displayed. Press  to access the second page. (2 of 2 is displayed.)</p>
	<p>Press this key to access the previous pages of a menu. For example, 2 of 2 displayed beside the  key indicates page two of a two page menu is displayed. Press  to access the previous page. (1 of 2 is displayed.)</p>
	<p>These unmarked keys are called 'softkeys' and are referred to by the text on the display beside them. For example, during a Preset, a pop-up window asks you to confirm the command. Press Confirm to continue, that is, press the softkey beside the displayed word 'confirm'. Similarly, pressing Cancel (the softkey beside the word 'cancel') stops the Preset.</p>
	<p>The arrow keys are used to select and change parameters such as instrument state names and offset values.</p>



These keys and connectors are associated with the measurement channels and are located on the right-hand side of the front panel.

Key

Function



Press this key to access the input frequency, and sensor calibration factor menus. Use these functions to improve the accuracy of your measurement.



Press this key to access the zero and calibration menus. Use these functions to improve the accuracy of your measurement.

Connector

Function

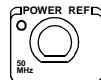

The power-reference is a 1 mW (0 dBm) 50 MHz signal available from a 50 ohm type-N connector. It is used for calibrating the sensor and meter system. If the meter is configured with Option 003, the connector is fitted to the rear panel. The Green LED beside the connector is lit when the calibrator is turned on.

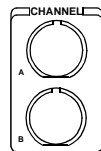

The sensor input connectors. The E4417A has two inputs, the E4416A has one input as shown in the photograph. If the meter is configured with Option 002 or Option 003, the connectors are fitted to the rear panel.

The Display Layout

The following figure details the display layout when the two windows are configured in dual numeric mode. Other display formats are available by pressing , **Disp Type**.







- The status reporting line displays five fields, three associated with either GPIB, RS232 or RS422 status and two associated with error and warning conditions. The first field displays either **RMT** (remote, GPIB, RS232 or RS422 operation) or **LCL** (local, front panel operation).

For GPIB operation, the second field displays **TLK** if the power meter is addressed to talk or **LSN** if it is addressed to listen. The third field indicates an **SRQ** (service request).

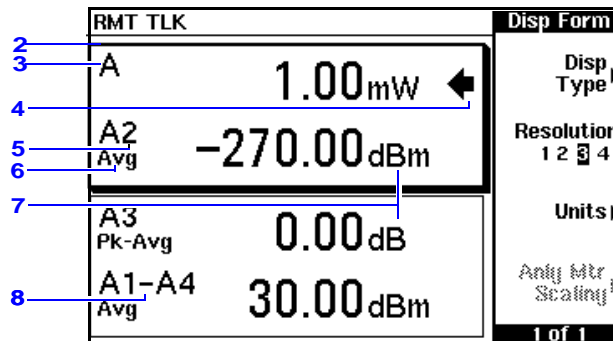
For RS232 and RS422 operation, the second field displays **RX** when data is being received. The third field displays **TX** when the power meter is transmitting data.

The fourth field indicates **ERR** for any error conditions. The last field is used to report error and warning messages.



- 2 There are two measurement windows. This is the upper measurement window. The shading around the window indicates it has been selected (using the , , or  keys). With numeric measurement results you can choose either two rectangular windows, a single enlarged window, or a full screen display by pressing . The display style is applied to the currently selected window or measurement line.
- 3 This field displays the channel being measured. This measurement line is the Upper Window/Upper Measurement.
- 4 The arrow indicates the currently selected measurement display line.
- 5 With an E-series E9320 power sensor connected, the channel and associated gate number are shown.
- 6 With an E-series E9320 power sensor connected, the associated measurement type is shown below the channel and gate number.
- 7 This field displays the measurement units, either dBm, dB, Watts, or percent (%).

NOTE

With an E-series E9320 power sensor connected, a measurement result of -270 dBm indicates the input power level is outwith the sensitivity of the sensor.

- 8 With an E-series E9320 power sensor connected, you can make combined measurements with a single channel meter. A dual channel meter extends this feature across both channels.

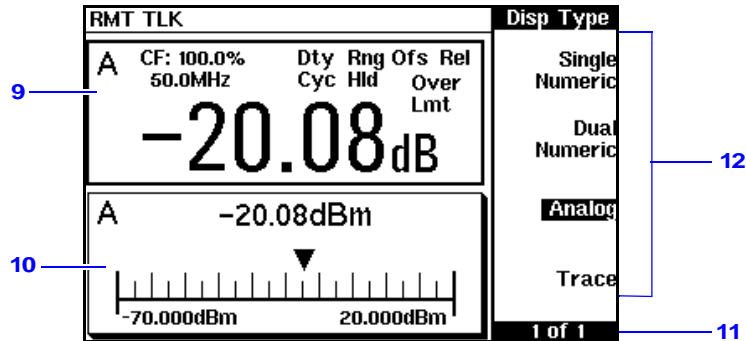

- 9** This window is configured to show a single numeric display.
- 10** This window is configured to show an analog meter which displays the measurement result and the meter scaling.
- 11** This field displays the number of pages in the current menu. For example, **1 of 2** indicates that there are two pages in the menu and the first page is currently displayed. Pressing **More** displays the next page, indicated by **2 of 2**. (**Prev** displays the previous menu page.)
- 12** The available softkey labels are displayed in these four fields. Additionally, settings associated with the labelled function are displayed.

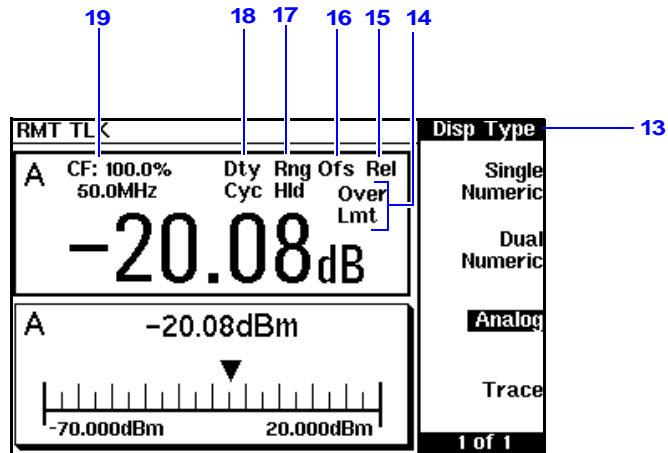

- 13** This field displays the menu title. For example, when the power meter is initially switched on the **Contrast** menu is displayed, and if for example, you press , the **Zero/Cal** menu is displayed.
- 14** This field indicates the measurement result is out with any configured upper or lower limits. If the measurement is within the limits this field is empty. If the measurement result is less than the minimum limit set, **Undr Lmt** is displayed. If the measurement result is more than the maximum limit set, **Over Lmt** is displayed.
- 15** This field displays **Rel** if relative mode is on.
- 16** This field displays **Ofs** if an offset is set.
- 17** This field displays **Rng Hld** if a range is selected.
- 18** This field displays **Dty Cyc** if a duty cycle is set. With an E-series E9320 power sensor connected, the field shows \mathcal{L} , \otimes , \downarrow , or f , depending on the trigger state.
- 19** The information in this field is displayed on two lines and depends on the sensor type, sensor calibration table, frequency dependent offset table currently selected, and the measurement frequency.

NOTE The following trace displays are only available when an E-series E9320 power sensor is connected.

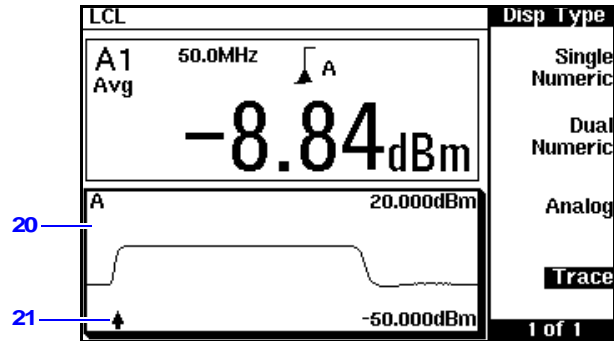

20 This window is configured to show a trace display. This is only available with an E-series E9320 power sensor connected. The captured trace and scaling are displayed.



21 The \blacktriangledown indicates the point on the trace where trigger event occurs.

NOTE Single or continuous triggering (**Sing Trig** or **Cont Trig**) must be selected from the **Acqn** menu to view a trace window. The **Acqn** menu is accessed by pressing **Trigger**, **Acqn**.

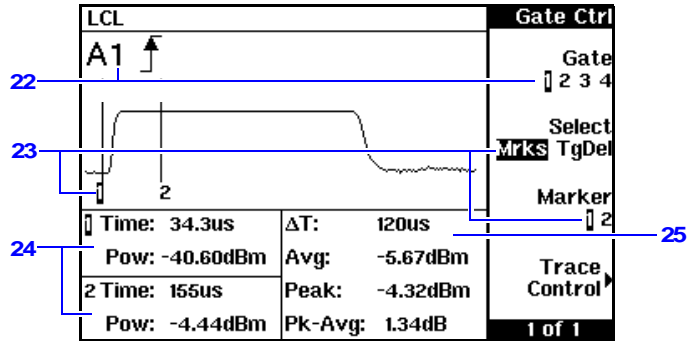
Trace is disabled when **Free Run** is selected.







This display shows the **Gate Ctrl** menu and associated tables and markers. The **Gate Ctrl** screen is accessed by pressing **Gate Control** from the **Trace Ctrl** menu or by pressing **Gate Control** from the **Gates** menu.



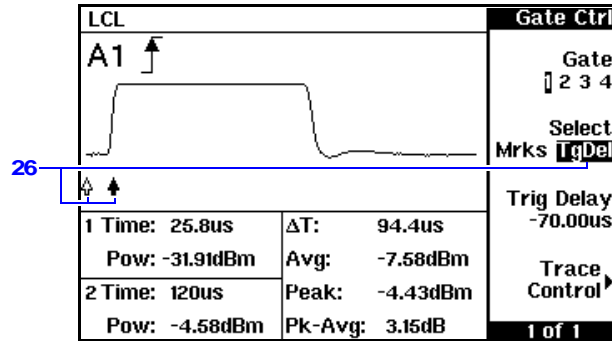

- 22 Pressing **Gate** scrolls through the 4 gates available for each channel. The selected gate number is repeated in the upper left corner of the window.
- 23 The markers, **1** and **2**, indicate the start and end points of the selected gate. Pressing **Marker 1 2** toggles between the two markers. You can use the  and  keys to move the active marker along the trace.
- 24 This table shows the time (**Time:**) from the configured trigger point and the instantaneous power level (**Pow:**) for both markers. A negative time value indicates a measurement before the trigger point.



NOTE Gate timing parameters are all related to your chosen trigger point. This may be different from the timing of the triggering event if you have configured a trigger delay. Refer to item 26 for more information.





- 25 This table shows the width of the gate **ΔT:** (time between the markers), and the average, peak, and peak-to-average ratio power measurements within the gate.



26 Pressing **Select TgDel** hides the gate markers and displays the trigger marker(s).  indicates when the trigger event occurs, whilst  shows the delayed trigger point. When the two points coincide only the delayed trigger  is shown.

In the example display, the  appears ahead of the  as a trigger delay of $-70.00 \mu\text{s}$ has been configured, placing the measurement trigger before the trigger event. You can configure the trigger delay by pressing **Select TgDel** and entering a numeric value or by pressing the  or  keys.

Gate and trigger markers are moved one pixel when the  or  keys are pressed and released. They are moved up to 5 pixels at a time when the keys are pressed and held. To reduce the time interval represented by one pixel, decrease the length of the displayed trace.

To indicate an off-screen trigger event,  or  is displayed. To indicate an off-screen trigger point,  or  is displayed.

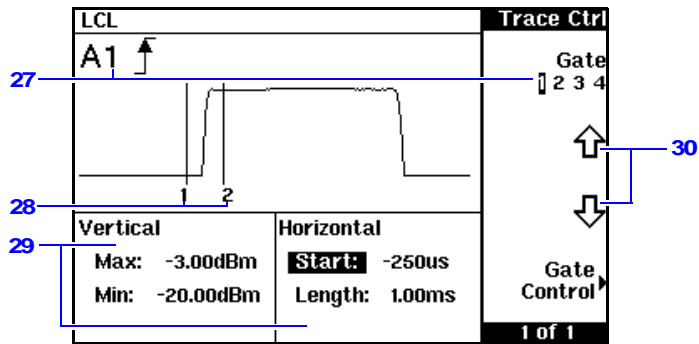







The **Trace Ctrl** screen is accessed by pressing **Trace Control** from the **Gate Ctrl** menu or by pressing **Trace Control** from the **Trace Setup** menu.

27 Pressing **Gate** scrolls through the 4 gates available for each channel. The selected gate number is repeated in the upper left corner of the window.

28 The markers, **1** and **2**, indicate the start and end points of the selected gate.

29 The vertical table shows the amplitude scaling of the trace display. The horizontal table shows the scale, and start point, relative to the measurement trigger, of the trace.

30 You can change any of the horizontal or vertical trace values using the  or  softkeys having first selected the parameter using the , , , and  keys.

Window Symbols

There are a number of different graphic symbols and pop up windows that can occur on the power meter display. These can occur for a variety of reasons such as when:

- an error or warning occurs.
- a confirmation is required.
- you are required to wait while the power meter carries out a procedure.
- you are required to select an entry from a list.
- you are required to enter an alphanumeric value.

Warning Symbol

The warning symbol is displayed either directly in the measurement window or in a pop up window when such an event occurs. A pop up window is displayed for approximately two seconds. The text in the pop up window gives details of the warning type. This symbol may also appear on a measurement window, for example, to indicate that a power sensor is not connected.



Confirmation Pop-up

This pop up window is displayed when you are required to press

Confirm to verify your previous selection. For example, prior to a



(Preset) being carried out.

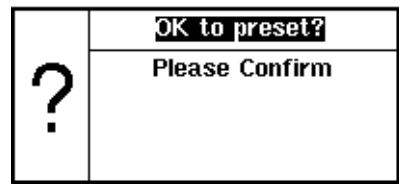



Wait Symbol

The wait symbol is displayed when the power meter is carrying out a procedure but no action is required from you. The symbol appears in a pop up window. It may appear, for example, during, zeroing or calibration.



1 of Many Entry Pop-up

This pop up window is displayed when you are required to select an entry using  and  from the list.

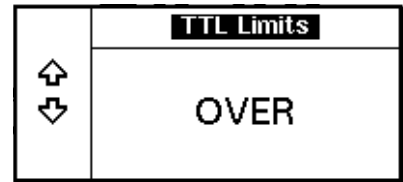





Configuration Conflict Pop-up

This pop up window is displayed when you make a configuration that conflict with a previous setup. The previous setup is lost.



Numeric or Alphanumeric Entry Pop-up

This pop up window is displayed when you are required to modify numeric or alphanumeric data. The  and  keys move the position of the cursor. The  and  keys increment and decrement the alphanumeric digit on which the cursor is currently positioned.

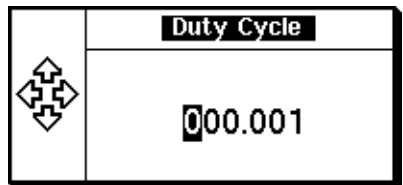



2 General Power Meter Functions

What You'll Find in This Chapter

This chapter describes the general operation of the EPM-P series power meters. It contains the following sections:

- Zeroing and Calibrating on page 38
 - Setting the Units of Measurement on page 49
 - Setting the Resolution on page 51
 - Making Relative Measurements on page 52
 - Setting Offsets on page 53
 - Setting Averaging on page 64
 - Step Detection on page 66
 - Setting Measurement Limits on page 67
 - Setting the Range on page 73
 - Recorder Output on page 76
 - Saving and Recalling Power Meter Configurations on page 79
 - Presetting the Power Meter on page 85
-

Zeroing and Calibrating

This section describes how to zero and calibrate the power meter and sensor combination. You should always zero the power meter prior to calibrating it.

Zeroing

Zeroing adjusts the power meter for a zero power reading with no power applied to the power sensor. During zeroing the wait symbol is displayed.

To zero the power meter and sensor:

Press  and the channel **Zero** softkey. The **Zeroing** message and wait symbol are displayed. On dual channel meters you can zero both channels sequentially by pressing **Zero Both**. During zeroing the wait symbol is displayed.

When to Zero? Zeroing of the power meter is recommended:

- when a 5⁰C change in temperature occurs.
- when you change the power sensor.
- every 24 hours.
- prior to measuring low level signals. For example, 10 dB above the lowest specified power for your power sensor.

Calibration

Calibration sets the gain of each power meter channel and sensor combination using a 50 MHz 1 mW (0 dBm) signal. Use the power meter's POWER REF as a traceable power reference or a suitable external reference signal. An essential part of calibrating is setting the correct reference calibration factor for the power sensor you are using. You must manually enter the reference calibration factor for an 8480 series power sensor. The reference calibration factor is automatically set for all E-series sensors.

During calibration the wait symbol is displayed. Offset, relative and duty cycle settings are ignored during calibration.

Some power sensors require adaptors or attenuator pads to enable connection to the POWER REF output. Refer to Table 1 on page 43 for details.

NOTE During calibration, the power meter automatically switches the power reference calibrator on (if it is not already on). After calibration, it switches it back to the state it was in prior to calibration.

Calibration with E-Series Power Sensors

This section describes the calibration procedure for E-series power sensors. The power meter identifies that an E-series power sensor is connected and automatically downloads the calibration table. Since there is no requirement to enter any calibration factors the channel **Ref CF %** and **Cal Fac %** softkeys are disabled. (These softkey labels are still visible but appear grayed out.)

Procedure Zero and calibrate the power meter/sensor combination as follows:

- 1 Ensure the power sensor is disconnected from any signal source.
- 2 Refer to the connection requirements in Table 1 and ensure the sensor is ready for connection to the power reference.
- 3 Press  and the channel **Zero** softkey to zero the channel. The **Zeroing** message and wait symbol are displayed.
- 4 Connect the power sensor to the POWER REF output.
- 5 Press the channel **Cal** softkey to start the calibration routine. The **Calibrating** message and wait symbol are displayed.

The power meter and sensor are now ready for use.

TIP You can reduce the steps required to carry out the zero and calibration procedure as follows:

- Connect the power sensor to the POWER REF output.
- Press  and **Zero + Cal**. (For dual channel meters, press **Zero + Cal**, **Zero + Cal A** or **Zero + Cal B** as required.)

NOTE Following calibration, ensure you remove/re-attach any attenuators or adaptors before making a measurement.

Calibration with 8480 Series Power Sensors

This section describes the calibration procedure for 8480 series power sensors. The reference calibration factor is entered manually.

NOTE For most 8480 series sensors the correct (A type or D type) linearity correction table is automatically selected. V8486A and W8486A sensors on page 42 show you how to change the linearity configuration.

- Procedure**
- 1 Ensure the power sensor is disconnected from any signal source.
 - 2 Refer to the connection requirements in Table 1 and ensure the sensor is ready for connection to the Power Reference.
 - 3 Check the current reference calibration factor setting by pressing

Zero Cal, **More**. The value is displayed under the channel **Ref CF %** softkey.

Does this setting match the value for the sensor? (The power sensor reference calibration factor can normally be found above the calibration factors table on the power sensor body.)

- 4 If required, change this setting by pressing the channel **Ref CF**. The reference calibration factor pop up window is displayed as shown in Figure 1.

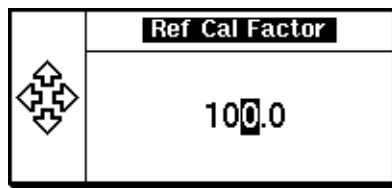

Figure 1 Reference Calibration Factor Pop Up Window

Use the **←**, **→**, **↑**, and **↓** keys to select and change the values as required.

- 5 Confirm your choice by pressing **%**.

- 6 Press **More** and the channel **Zero** softkey to zero the channel. The **Zeroing** message and wait symbol are displayed.
- 7 Connect the power sensor to the POWER REF output.
- 8 Press the channel **Cal** softkey to start the calibration routine. The **Calibrating** message and wait symbol are displayed.

NOTE Following calibration, ensure you remove/re-attach any attenuators or adaptors before making a measurement.

V8486A and W8486A sensors

V8486A and W8486A sensors require that you manually select D type linearity correction. Subsequent connection of another A type sensor will result in a warning message **Linearity Override May be Required**. You must then manually select A type correction.

Select the linearity to be applied as follows:

Press **System**, **Tables** and press the channel **Linearity** softkey to highlight **Atyp** or **Dtyp**.

Linearity can be manually configured for each channel. For example, to set D type linearity on channel B:

Press **System**, **Tables** and press **B Linearity** to highlight **Dtyp**.

Table 1 Power Sensor Connection Requirements

Sensor	Connection Requirements
E9321A E9322A E9323A E9325A E9326A E9327A	These power sensors connect directly to the POWER REF.
E9300A E9300H E9301A E9301H E9304A	These power sensors connect directly to the POWER REF.
E9300B E9301B	These power sensors are configured with an attenuator. Prior to calibration this attenuator must be removed. Replace the attenuator before making measurements.
E4412A E4413A	These power sensors connect directly to the POWER REF.
8481A 8481H 8482A 8482H	These power sensors connect directly to the POWER REF.
8481D 8484A	Prior to calibration, an Agilent 11708A 30 dB reference attenuator should be connected between the power sensor and the POWER REF. Remove this attenuator from the power sensor input before making measurements.
8483A	This power sensor requires a 75 Ω (f) to 50 Ω (m) N-Type adapter (1250-0597) to connect to the POWER REF. Remove this adapter before making measurements.
R8486A Q8486A V8486A W8486A R8486D Q8486D	These waveguide power sensors have two connectors. Use the N-Type connector to calibrate the power meter.
8481B 8482B	These power sensors are configured with an attenuator. Prior to calibration this attenuator must be removed. Replace the attenuator before making measurements.

Sensor	Connection Requirements
8485A	This power sensor requires an APC 3.5 (f) to 50 Ω (m) N-Type adapter (08485-60005) to connect to the POWER REF. Remove this adapter before making measurements.
8485D	Prior to calibration, an Agilent 11708A 30 dB reference attenuator and an APC 3.5 (f) to 50 Ω (m) N-Type adapter (08485-60005) should be connected between the power sensor and the POWER REF. Remove this attenuator and adaptor before making measurements.
8487A	This sensor requires an APC 2.4 (f) to 50 Ω (m) N-Type adapter (08487-60001) to connect to the POWER REF. Remove this adapter before making measurements.
8487D	Prior to calibration, an Agilent 11708A 30 dB reference attenuator and an APC 2.4 (f) to 50 Ω (m) N-Type adapter (08487-60001) should be connected between the power sensor and the Power Ref. Remove this adapter before making measurements.

Zero/Cal Lockout

The Zero/Cal Lockout facility can help you make sure that a measurement cannot be made until the power meter/sensor combination has been zeroed and calibrated.

When the Zero/Cal Lockout facility is enabled and a sensor is first connected, the message **Please Zero and Cal** is displayed.

When you zero the sensor the message changes to **Please Cal**. If you calibrate the sensor before zeroing it, the message changes to **Please Zero**.

Dual Channel Dual channel meters display channel specific messages when a sensor is connected. The Zero/Cal Lockout configuration is applied to both channels - it cannot be applied to one channel only.

You can enable and disable the Zero/Cal Lockout facility from the System menu or the Zero/ Cal menu as follows:

Press , , **Must Cal Off** or **On**.

Similarly,

press , , **Must Cal Off** or **On**.

Zeroing and Calibrating Using TTL Inputs

You can use the TTL inputs on the rear panel Rmt I/O port to initiate zero and calibration cycles on the power meter. The connector is an RJ-45 series shielded modular jack with the TTL input pins connected as shown in Figure 2.

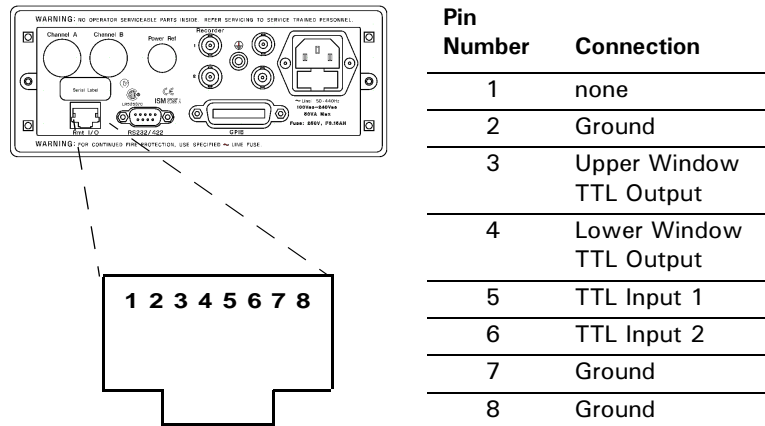

Figure 2 Rmt I/O Port TTL Inputs

The TTL inputs are active low and control the zero and calibration functions as shown in Table 2.

Table 2 TTL Input Control Logic

Input 1	Input 2	Single Channel	Dual Channel
1	1	None	None
1	0	CAL	CAL A
0	1	ZERO	ZERO BOTH
0	0	CAL	CAL B

Effective control of the zero and calibration cycles using the TTL inputs depends on correct timing of the input signals as shown in Table 3 and Table 4.

Table 3 TTL Inputs Timing Diagram 1

Timing of zero/cal inputs for conditions "01" and "10".

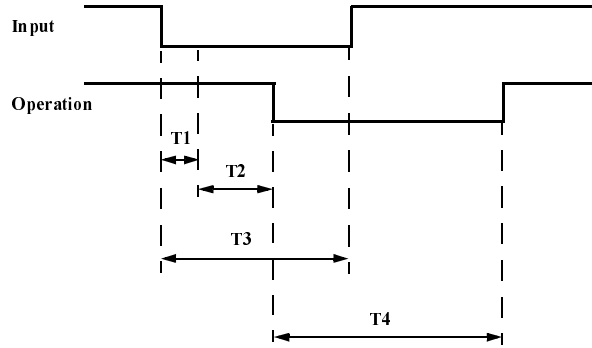

Time	Description	Value
T1	Minimum width of input	300 ms
T2	Time between input detection and start of zero/cal cycle. This is determined by the number of averages x sample rate, or if there is an existing zero/cal operation in progress, the time for this current operation to complete. Note that the worst case is 1024 averages x 50 ms = 51.2 s. For front panel operation (in free run mode) the time is 1 x 50 ms.	Max: 50 ms (typical) Min.: 0 ms
T3	Maximum width of input. Longer inputs may cause a subsequent zero/cal operation some time after the current one is complete.	4 s
T4	Time for zero/cal operation to complete. Zero Both (dual channel meters) is a sequential operation and requires double that of single channel meters.	Zero: 10 s (8480series) 12s (E-series) 45s (E9320series) Cal: 6 s (8480 series) 7 s (E-series) 15s (E9320series)

All timings based on 100 ms firmware polling.

Table 4 TTL Inputs Timing Diagram 2

Timing of zero/cal inputs for condition "00".

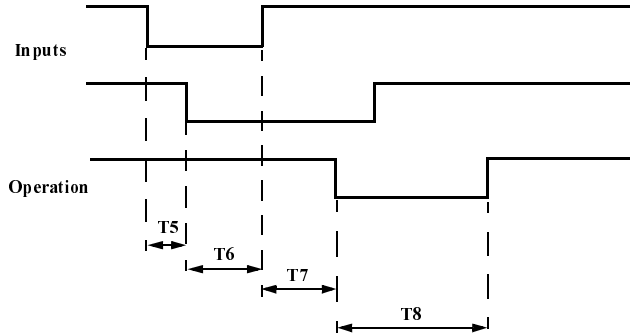

Time	Description	Value
T5	Maximum time between inputs going low.	100 ms
T6	Minimum overlap of low inputs.	200 ms
T7	Time between input detection and start of zero/cal cycle. This is determined by the number of averages x sample rate, or if there is an existing zero/cal operation in progress, the time for this current operation to complete. Note that the worst case is 1024 averages x 50 ms = 51.2 s. For front panel operation (in free run mode) the time is 1 x 50 ms.	4 s
T8	Time for cal operation to complete.	Cal: 6 s (8480 series) 7 s (E series) 30 s (E9320 series)

All timings based on 100 ms firmware polling.

If both TTL inputs are simultaneously low under any circumstances other than those shown above, the operation is undefined.

Setting the Units of Measurement

The **Units** menu is used to select the measurement units for the currently selected window. These can either be logarithmic (dBm or dB) or linear

(Watt or %) units. Presetting () the power meter sets the measurement units to dBm (logarithmic units). Table 5 and Table 6 show the units applicable to each measurement mode.

Press , **Units**. Select the unit of measurement from **dBm**, **W**, **dB**, and **%**. Softkeys which cannot be selected in your particular mode of operation are grayed out.

NOTE When the unit of measurement is set to Watt, it is possible that negative power measurements may be displayed when measuring low power levels.

Table 5 Measurement Units - Single Channel Meters

Measurement Mode	Relative Mode Off	Relative Mode On
Log	dBm	dB
Linear	Watt	%

Table 6 Measurement Units - Dual Channel Meters

Measurement Mode	Relative Mode Off	Relative Mode On
Ratio	Log	dB
	Linear	%
Difference	Log	dBm
	Linear	Watt

Selecting Units of Measurement from the Softkeys

In some menus you are required to enter the units of measurement for power. In some cases, due to the wide power range available, the following menu is displayed:

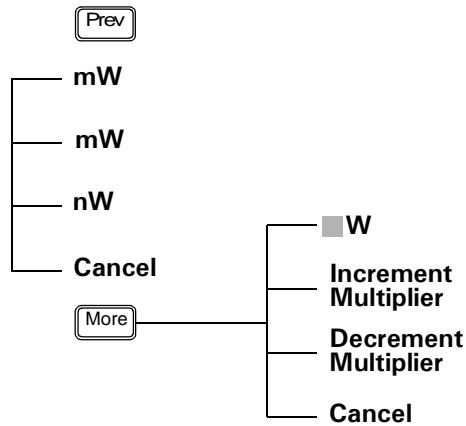

NOTE Some softkeys may be grayed out so that an invalid value cannot be entered.

Pressing **Increment Multiplier** or **Decrement Multiplier** increases or decreases the multiplier shown in front of **W**. Pressing **W** after the correct multiplier has been selected confirms the entry.

Setting the Resolution

The resolution of each of the power meter's windows can be set to four different levels (1, 2, 3 or 4).

These four levels represent:

- 1, 0.1, 0.01, 0.001 dB respectively if the measurement suffix is dBm or dB.
- 1, 2, 3 or 4 significant digits respectively if the measurement suffix is W or %.

The default value is 0.01 dB (3 digits).



To set the resolution on the currently selected window:

- 1 Press . The current setting of the resolution is highlighted under the **Resolution** softkey.
- 2 To change this setting press **Resolution** until the required resolution setting is highlighted.

Making Relative Measurements

Relative mode enables comparison of a measurement result to a reference value. The relative reading, or difference, can be displayed in either dB or % terms. When the measurement result is displayed in % a prefix multiplier may be shown.

Procedure To set a reference value on the currently selected window:

- 1 Press , **Rel/Offset** to display the **Rel/Offset** menu.
- 2 Confirm the power meter is measuring the signal you want to use as the reference.
- 3 Press **Rel** to use the current reading as the reference value. You can compare the measurement result in dB or percentage (%).
Rel Off On is automatically set to **On** when **Rel** is pressed.
- 4 To change the measurements press , **Units**. Press **dB** or **%** as required.
- 5 Successive measurements are now displayed relative to the reference value. The relative mode can be disabled and re-enabled by pressing , **Rel/Offset**, **Rel Off On** to select **Off**.

Rel is displayed in the window when the measurement line it is applied to is displayed (see Figure 3).

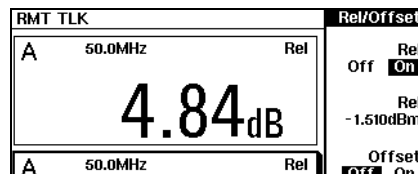

Figure 3 Rel Indicator

NOTE The **Rel** symbol is not displayed when the associated measurement is displayed in **Dual Numeric** or **Analog** format.

Setting Offsets

The power meter can be configured to compensate for a signal loss or gain in your test setup. The power meter allows you to apply offsets at three different points in the measurement path as shown in Figure 4.

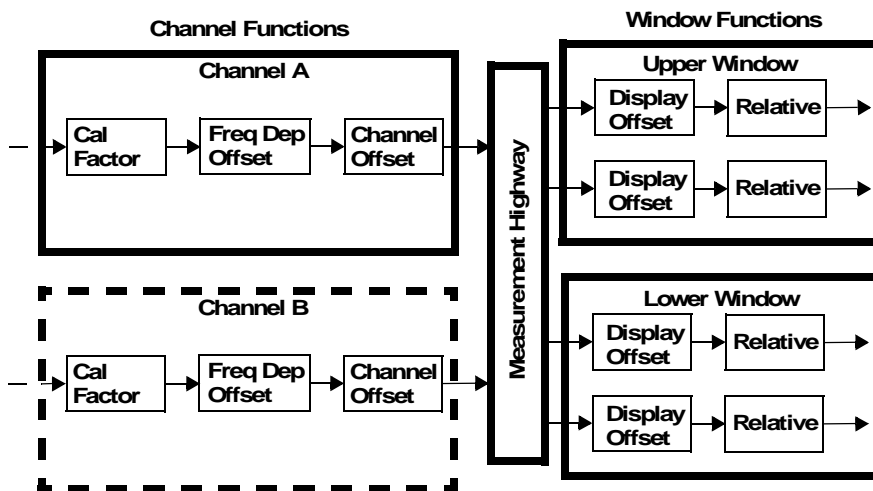

Figure 4 Simplified Measurement Path

Applying a Channel Offset or a Frequency Dependent Offset allows you to compensate each channel individually prior to any mathematical functions. An overall offset can then be applied if required using the Display Offset.

Setting Channel Offsets

This gain or loss is applied to the measured power before any mathematical functions, display offsets or relative functions are included.

Offsets are entered in dB. The allowable range of values is -100 dB to +100 dB. A positive value compensates for a loss, and a negative value compensates for a gain.

To enter a channel offset:

- 1 Press **Channel** to display the **Channel Setup** screen. Confirm the required channel setup is displayed. Press **Channel Ch.** to change channel if required.
- 2 Use the **▲** and **▼** keys to highlight the **Offset:** setting.
- 3 Press **Change** to select **On**.
Press **▼** to highlight the **Offset:** value and press **Change** to display the **Offset** pop-up. Use the **▲**, **▶**, **▲**, and **▼** keys to select and change the values as required.
- 4 Confirm your choice by pressing **dB**.
- 5 Press **Done** to complete the offset entry.

If either a channel or a display offset is set, **Ofs** is displayed.

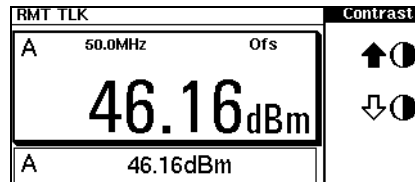

Figure 5 Offset applied

NOTE The **Ofs** symbol is not displayed when the associated measurement is displayed in **Dual Numeric** or **Analog** format.

Setting Display Offsets

This gain or loss is applied to the measured power after any channel offsets or mathematical functions have been included.

Offsets are entered in dB. The allowable range of values is -100 dB to +100 dB. A positive value compensates for a loss, and a negative value compensates for a gain.

Procedure Enter a display offset on the currently selected window:

- 1 Press , **Rel/Offset** to display the **Rel/Offset** menu.
- 2 Press **Offset** to highlight **On**.
- 3 Press **Offset** to display the **Offset** pop-up. (The current offset value is shown below the **Offset** softkey.)

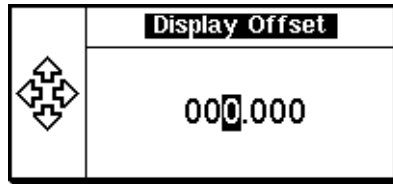





Figure 6 Offset Pop-up

Use the , , , and  keys to select and change the values as required.

- 4 Confirm your choice by pressing **dB**.
- 5 Press **Done** to complete the offset entry.

If either a channel or a display offset is set, **Ofs** is displayed.

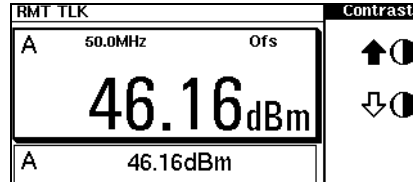

Figure 7 Offset applied

NOTE The **Ofs** symbol is not displayed when the associated measurement is displayed in Dual Numeric, Trace, or Analog format.

The display offset is a function of the window. Any of the 4 measurement display lines can have its own offset.

Setting Frequency Dependent Offsets



Frequency dependent offset tables provide a quick and convenient method of compensating for frequency related changes in the response of your test system. Note that when selected, frequency dependent offset corrections are applied IN ADDITION to any correction for sensor frequency response.

The power meter is capable of storing 10 frequency dependent offset tables of up to 80 frequency points each.

To use frequency dependent offset tables:

- 1 Select the table to be applied to a channel. Refer to see [Selecting a Frequency Dependent Offset Table](#) on page 58 for further information. If you require to edit the table refer to see [Editing Frequency Dependent Offset Tables](#) on page 61 for further information.
- 2 Zero and calibrate the power meter. The reference calibration factor used during the calibration is automatically set by the power meter from the sensor calibration table (if selected).
- 3 Specify the frequency of the signal you want to measure. The calibration factor/offset is automatically set by the power meter from the sensor calibration table (if selected) and the frequency dependent offset table. Refer to see [Procedure](#) on page 58 for further information.
- 4 Make the measurement.

Selecting a Frequency Dependent Offset Table

You can select a frequency dependent offset table from the  key menu or the . The **State** column indicates if any frequency dependent offset tables are currently selected. The **Offset Tbls** screen is shown in Figure 8.

RMT TLK		Offset Tbls	
Tbl	Name	State	Pts
A	CUSTOM_A	off	5
B	CUSTOM_B	off	0
C	CUSTOM_C	off	0
D	CUSTOM_D	off	0
E	CUSTOM_E	off	0
F	CUSTOM_F	off	0
G	CUSTOM_G	off	0
H	CUSTOM_H	off	0
I	CUSTOM_I	off	0
J	CUSTOM_J	off	0

Edit
Table

Table





Off On



Done

1 of 1

Figure 8 Offset Tables

Procedure Select an offset table as follows:

- 1 Ensure the power meter/sensor combination has been zeroed and calibrated.
- 2 Press:
 - , **Tables**, **Freq. Dep. Offset** or,
 - press  and after selecting the required channel, use the  and  keys to select **FDO Table**, and press **Change**.





The **Offset Tbls** screen is displayed.
- 3 Use the  and  keys to highlight one of the 10 table titles and press **Table** to highlight **On**.

NOTE When no data is contained in the highlighted table, the **Table** key is disabled (greyed out).

- 4 Press **Done** to complete the selection of the offset table.

RMT TLK		Input Set
Channel Setup		Change
Sensor Mode:	AVG only	
Range:	AUTO	
Filter:	AUTO 128	Gates >
Duty Cycle:	Off 1.000%	
Offset:	Off 0.000dB	Trace
Frequency:	200.00MHz	Setup >
CF Table:	Off	
FDO Table:	CUSTOM_A	Done
Video Avg:	Off 4	
Video B/W:	Max	
Step Detect:	On	
		1 of 1

Figure 9 Frequency Dependent Offset Table selected

- 5 Press **Done** again to display the measurement screen.
- 6 Press . The current setting of the frequency is displayed under the channel **Freq** softkey.
- 7 To change the frequency press the channel **Freq** softkey. The frequency is displayed in a pop up window. Use the , , , and  keys to select and change the values as required.
- 8 To confirm your choice press the appropriate unit softkey.
- 9 Connect the power sensor to the signal to be measured.
- 10 The measurement result, including offset, is now displayed.

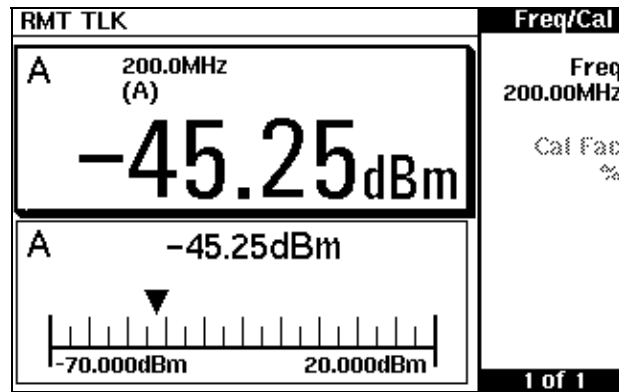



Figure 10 Frequency Dependent Offset Configured

NOTE If the measurement frequency does not correspond directly to a frequency in the sensor calibration table (if selected) and the frequency dependent offset table being used, the power meter calculates the calibration factor and offset using linear interpolation. If you enter a frequency outside the frequency range defined in the sensor calibration table or the frequency dependent offset table, the power meter uses the highest or lowest frequency point in the appropriate table to set the calibration factor and offset.

Editing Frequency Dependent Offset Tables

There are ten frequency dependent offset tables named CUSTOM_A through CUSTOM_J. They do not contain any data when the power meter is shipped from the factory.









You cannot delete any of the 10 existing frequency dependent offset tables or create any additional tables. However, you can enter values into the 10 existing tables. Each frequency dependent offset table can contain a maximum of 80 frequency points.

To view the frequency dependent offset tables currently stored in the power meter, press , **Tables**, **Freq. Dep. Offset**. The **Offset Tbls** screen is displayed as shown in Figure 8 on page 58.

Creating frequency dependent offset tables requires the following steps:

1. Identify and select the table you want to edit.
2. Rename the table.
3. Enter the frequency and calibration factor data pairs.
4. Save the table

Procedure First select the table you want to edit as follows:

- 1 Press , **Tables**, **Freq. Dep. Offset** to display the **Offset Tbls** screen.
- 2 Choose the table you want to edit using the  and  keys. Press **Edit Table** to display the **Edit Offset** screen as shown in Figure 11.
- 3 Highlight the table title using the  and  keys. Press **Change** and use the , ,  and  keys to select and change the characters to create the name you want to use.
 - Pressing **Insert Char** adds a new character to the right of the selected character.
 - Pressing **Delete Char** removes the selected character.

4 Press **Enter** to complete the entry.









NOTE A frequency in the range of 0.001 MHz to 999.999 GHz can be entered. A calibration factor in the range of 1% to 150% can be entered. The following rules apply to naming sensor calibration tables:

- The name must consist of no more than 12 characters.
- All characters must be upper or lower case alphabetic characters, or numeric (0-9), or an underscore (_).
- No other characters are allowed.
- No spaces are allowed in the name.

RMT TLK		Edit Offset
Name: CUSTOM_A		Change
Freq	Offset	Insert
5.000MHz	90.0%	Delete
6.000MHz	80.0%	Done
7.000MHz	70.0%	
8.000MHz	60.0%	
9.000MHz	50.0%	
		1 of 1

Figure 11 "Edit Offset" Screen with some data added

Enter (or edit) the frequency and offset pairs as follows:

- 5 Press **Insert** to add a new frequency value or use the , ,  and  keys to select the frequency value in the table.
- 6 Enter the value or press **Change** and use the , ,  and  keys to enter the required frequency. Complete the entry by pressing the **GHz**, **MHz** keys.

7 Enter the offset using the , ,  and  keys. Complete the entry by pressing the **%** key.

Continue adding/editing values until you have entered all the data you require.

8 When you have finished editing the table press **Done** to save the table.

NOTE If you measure a signal with a frequency outside the frequency range defined in the frequency dependent offset table, the power meter uses the highest or lowest frequency point in the frequency dependent offset table to calculate the offset.

Setting Averaging

The power meter uses a digital filter to average power readings. The number of readings averaged can range from 1 to 1024. This filter is used to reduce noise, obtain the desired resolution and to reduce the jitter in the measurement results. Increasing the value of the filter length reduces measurement noise. However, the time to take the measurement is increased. You can select the filter length or you can set the power meter to auto filter mode. The default is **AUTO**.

When the auto filter mode is enabled, the power meter automatically sets the number of readings averaged together to satisfy the filtering requirements for most power measurements. The number of readings averaged together depends on the resolution and the power level currently being measured.

Figure 12 Averaged Readings

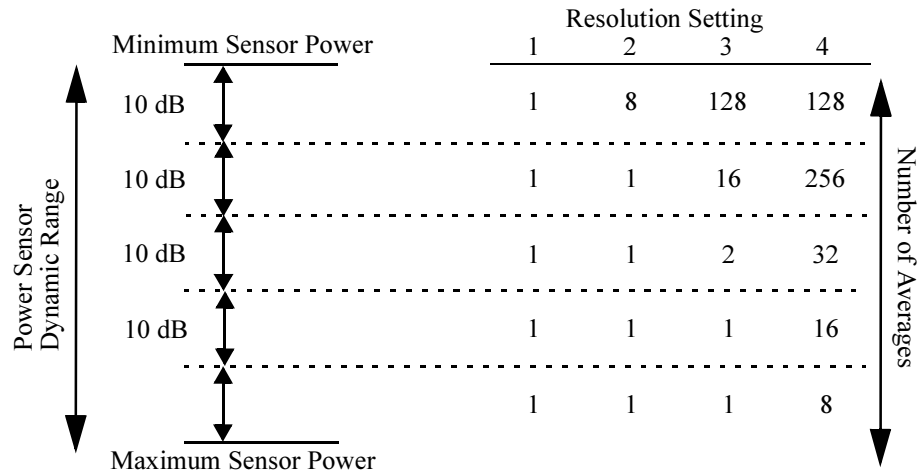

Figure 12 shows the typical the number of readings averaged for each range and resolution when the power meter is in auto filter mode and is set to normal speed mode. The EPM-P series power meters recognize different sensor types when they are connected and configure suitable averaging automatically.

Resolution is a measurement display function and not a channel function. In the case where a channel is set up in both the upper and lower window and the resolution settings are different, the highest resolution setting is taken to calculate the averaging number.

These four resolution levels represent:

- 1, 0.1, 0.01, 0.001 dB respectively if the measurement suffix is dBm or dB.
- 1, 2, 3 or 4 significant digits respectively if the measurement suffix is W or %.

Procedure Set averaging as follows:

1 Press **Channel** and select the channel you want to set up. The current **Filter:** setting (**AUTO**, **MAN**, or **OFF**) is shown on the **Channel Setup** screen.

2 Use the **←**, **→**, **↑**, and **↓** keys to select the **Filter:** setting.

3 Press **Change** to step through the available settings.

If you have selected **AUTO** or **OFF** proceed at step 7. If you have selected **MAN** proceed as follows:

4 Use the **←**, **→**, **↑**, and **↓** keys to select the **Filter:** value.

5 Press **Change** to display the Filter Length Pop-up.

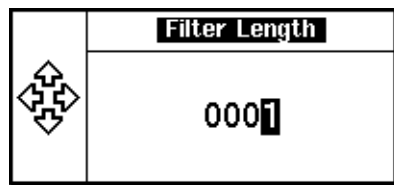

Figure 13 Filter Length Pop-up



6 Use the **←**, **→**, **↑**, and **↓** keys to enter the required value and press **Enter**.

7 Press **Done** to close the Channel Setup screen.

Step Detection

To reduce the filter settling time after a significant step in the measured power the filter can be set to re-initialize upon detection of a step increase/decrease in the measured power. Step detection can be set in both manual and automatic filter modes.

Procedure Set step detection as follows:

- 1 Press . On dual channel meters select the required channel.
- 2 Use the  and  keys to select the **Step Detect** setting.
- 3 Press **Change** to set step detection **On** or **Off** as required.
- 4 Press **Done**.

Setting Measurement Limits

You can configure the power meter to detect when a measurement is outwith a predefined upper and/or lower limit value.

Limits are windows or measurement display line based and can be applied to power, ratio or difference measurements. In addition, the limits can be set to output a TTL logic level at the rear panel Rmt I/O port when the predefined limits are exceeded

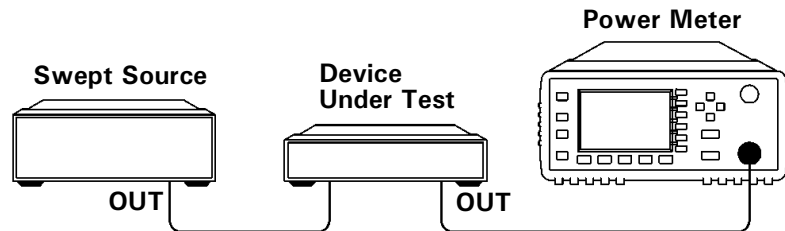

Figure 14 Limits Checking Application.

In this application a swept frequency signal is applied to the input of the Device Under Test. The power meter measures the output power. The limits have been set at +4 dBm and +10 dBm. A fail occurs each time the output power is outside these limits as shown in Figure 15.

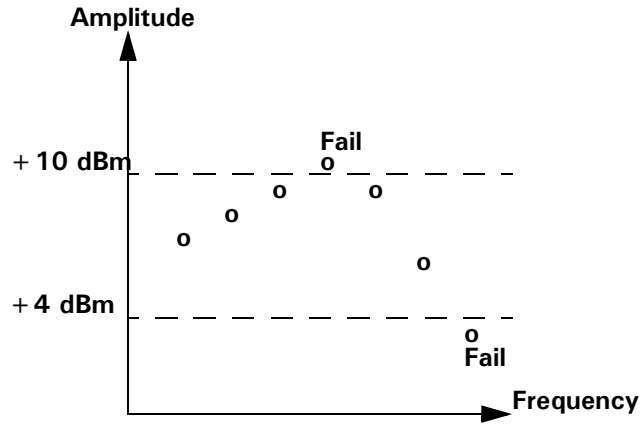

Figure 15 Limits Checking Results

Setting Limits

The power meter can be configured to verify the current measurement in any measurement line against predefined upper and/or lower limit values. The range of values that can be set for the upper and lower limits and the default values depends on the measurement units in the currently selected measurement line - see Table 7

Table 7 Range of Values for Window Limits

Window Units	Max	Min.	Default	
			Max	Min.
dB	+ 200 dB	-180 dB	60 dB	-120 dB
dBm	+ 230 dBm	-150 dBm	90 dBm	-90 dBm
%	999.9 X%	100.0 a%	100.0 M%	100.0 p%
W	100.000 XW	1.000 aW	1.000 MW	1.000 pW

Procedure Set the limits as follows:

- 1 Press **Meas Setup**, **Limits**. The current setting of the maximum and minimum limits for the selected measurement line are displayed under the **Max** and **Min** softkeys respectively.
- 2 Use the **▲**, and **▼** keys to select the measurement line you want to configure.
- 3 Change these settings by pressing **Max** or **Min** and use the **◀**, **▶**, **▲**, and **▼** keys to set the required values in the pop-up windows. Complete the entry by pressing the required power unit softkey.

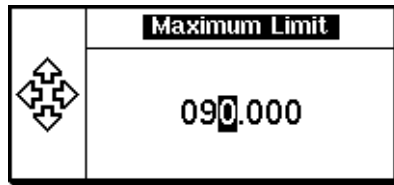

Figure 16 Setting Maximum Limit

- 4 To enable limit checking press **Limits** to select **On**.
- 5 Repeat this process for each required measurement line.

Limits can be disabled and re-enabled simply by pressing **Limits Off On**.

TTL outputs

The limits can also be set to output a TTL logic level at the rear panel Rmt I/O port when the predefined limits are exceeded. You can switch the rear panel TTL outputs on or off; set the TTL output level to active high or low; and determine whether the TTL output represents an over limit condition, under limit condition or both. Any two of the four measurement line limit conditions can be connected to either TTL output line.

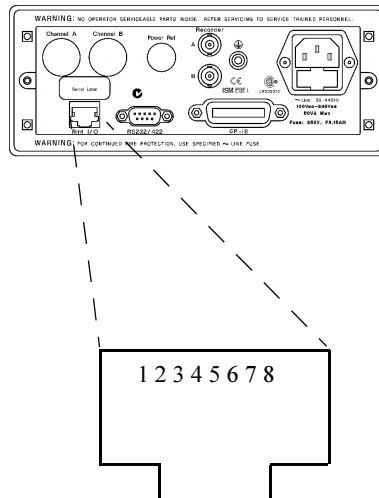

The TTL connector is an RJ-45 series shielded modular jack assembly with the TTL output pins connected as shown in Figure 17.



Pin Number	Connection
1	none
2	Ground
3	TTL Output 1
4	TTL Output 2
5	TTL Input 1
6	TTL Input 2
7	Ground
8	Ground

Figure 17 Remote I/O TTL Outputs

Procedure Set the TTL Output as follows:

- 1 Press , **Limits** **TTL Output**.
- 2 Use the , and  keys to select the measurement line you want to configure.

- 3 Press **TTL Output**.

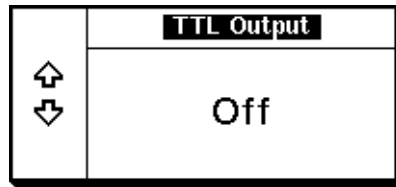



Figure 18 TTL Output Pop-up



- 4 Use the , and  keys to select TTL Output line 1, 2, or Off. Press **Enter** to confirm your choice. The new setting appears under the **TTL Output** softkey.

NOTE If you have selected a TTL Output line previously configured for another measurement, a warning message is displayed:



Figure 19 Example of TTL Disconnect Warning Message

Your new connection over-rides the previous configuration which is now disconnected.

- 5 Press **Limits**. The TTL output can indicate an over limit condition, under limit condition or both. Use the , and  keys to select your choice from the pop-up. Press **Enter** to confirm your choice.

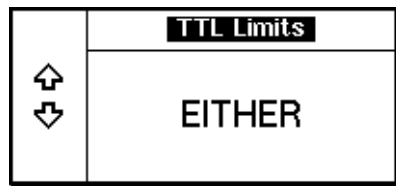

Figure 20 TTL Limits Pop-up

- 6 You can choose a high or low level TTL output to represent a limits failure. Press **Fail O/P** to select **High** or **Low** to set a logical '1' or logical '0' for a limits failure.

Checking for Limit Failures

Limit failures are displayed in the appropriate field in the measurement window on the power meter's display as shown in Figure 21.

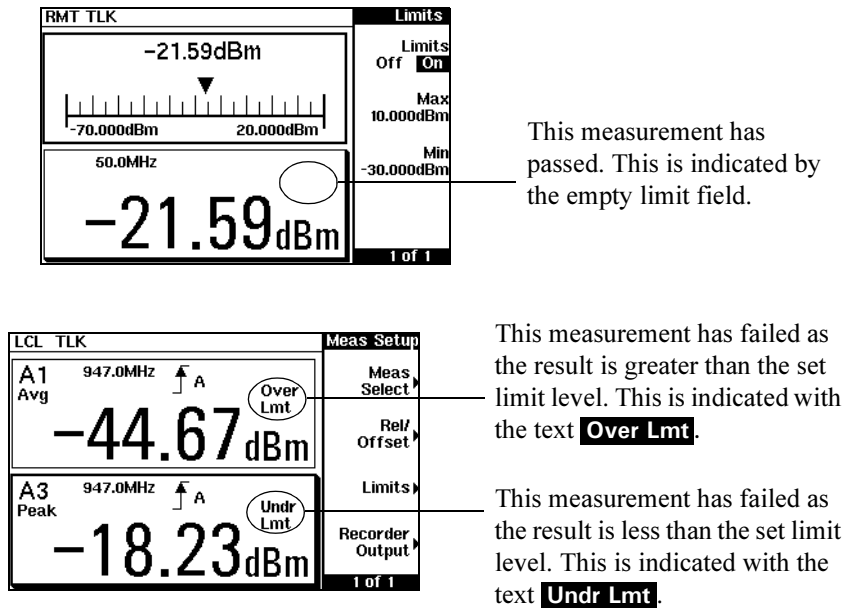





Figure 21 Limit Failures

Setting the Range

The power meter has no internal ranges. The only ranges that can be set are those of the E-series power sensors. With an E-series power sensor the range can be set either automatically or manually. There are two manual settings, **LOWER** and **UPPER**. The lower range is more sensitive than the higher range. Use autoranging when you are not sure of the power level you will be measuring. Use a manually configured range when you want to ensure there is no range switching during the measurement. The default is **AUTO**.

Procedure Set the range as follows:

- 1 Press  to display the **Channel Setup** screen. The current **Range:** setting is displayed.
- 2 Use the , and  keys to select the **Range:** setting.

RMT TLK		Input Set
Channel Setup		Change
Sensor Mode:	Normal	Gates ▶
Range:	AUTO	Trace Setup ▶
Filter:	AUTO 2	Done
Duty Cycle:	Off 1.000%	
Offset:	Off 0.000dB	
Frequency:	50.000MHz	
CF Table:	Off	
FDO Table:	Off	
Video Avg:	Off 4	
Video B/W:	Med	
Step Detect:	On	
		1 of 1

Figure 22 Channel Setup - Range

- 3 Press **Change** and choose **AUTO**, **LOWER**, or **UPPER** as required.
- 4 Press **Done** to confirm your choice.

Scaling the Analog Display

Configure a measurement displayed in **Analog** format as follows:

1. Press **Meas Display**, **More**.
2. Use the **Left**, **Right**, or **Up/Down** keys to select the analog measurement window.
3. Press **Anlg Mtr Scaling**.

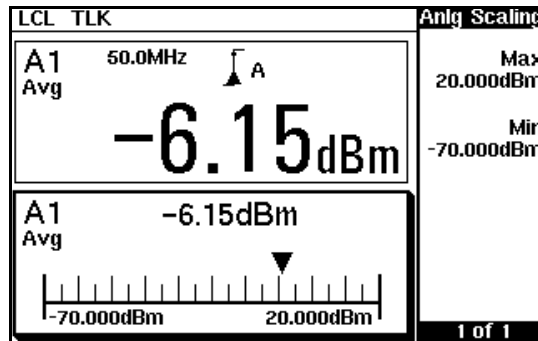

Figure 23 Analog display in lower window

The **Max** and **Min** scale values are shown on the analog display and adjacent to the softkey labels.

4. Press **Max** and use the **Left**, **Right**, **Up**, **Down** keys to configure the required value in the **Meter Maximum** pop-up window. Press **dBm**, **mW**, **uW**, or **nW**, to complete the entry.

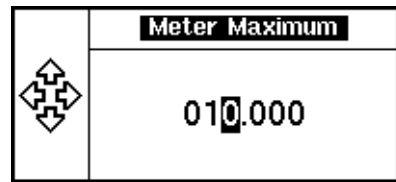





Figure 24 Meter Maximum Pop-up

5. Similarly, press **Min** and use the , , ,  keys to configure the required value in the **Meter Minimum** pop-up window. Press **dBm**, **mW**, **uW**, or **nW**, to complete the entry.

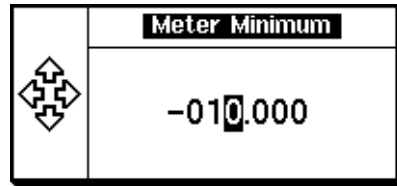

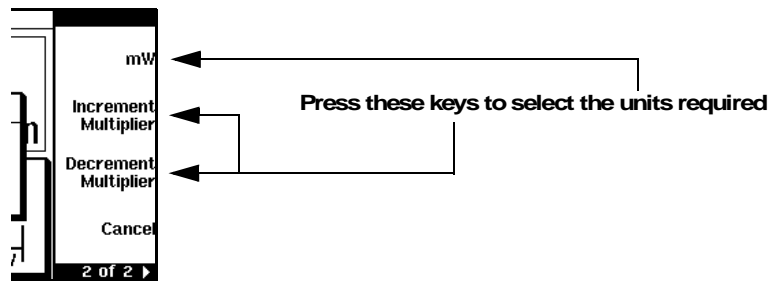



Figure 25 Meter Minimum Pop-up

TIP If you have selected linear scaling for the analog measurement and the units you require are outwith the range of the displayed menu, an additional menu is available. When the pop-up is displayed, you can press  to access the increment/decrement multiplier menu. Use the



Increment Multiplier or **Decrement Multiplier** to display the required units. Press the units softkey () to complete the entry.

Recorder Output









The rear panel Recorder Output connectors (A and B) produce a dc voltage that corresponds to the power level in Watts of the channel, depending on the measurement mode. This dc voltage ranges from 0 to +1 Vdc. The output impedance is typically 1 k Ω . Channel and display offsets, and duty cycle have no effect on the Recorder Outputs.

For example, the Recorder Outputs can be used to:

- record swept measurements
- level an output from a source using external leveling, or
- monitor the output power

To access the **Recorder** menu press , **Recorder Output**. This menu allows you to switch the Recorder Output signal either on or off. The **Max Power** and **Min Power** softkeys allow you to scale the power levels to represent the 1 V_{dc} maximum and 0 V_{dc} minimum output voltage of the Recorder Output.

Procedure Configure the recorder output as follows:

- 1 From a measurement display screen, use the , , or  keys to select the measurement window or measurement display line you want to connect to the recorder output.
- 2 Press , **Recorder Output** and **Output** to select **On**.
- 3 Press **Max Power** and use the , , , and  keys to enter the power level you want to generate a 1 V_{dc} output in the **Recorder Maximum Pop-up**. Press **dBm**, **mW**, **uW**, or **nW**, to complete the entry.

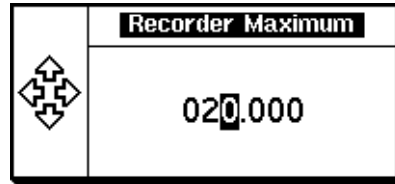

Figure 26 Recorder Maximum Pop-up

- 4 Similarly, press **Min Power** and use the \leftarrow , \rightarrow , \uparrow , and \downarrow keys to enter the power level you want to generate a 0 V_{dc} output in the **Recorder Minimum Pop-up**. Press **dBm**, **mW**, **uW**, or **nW**, to complete the entry.

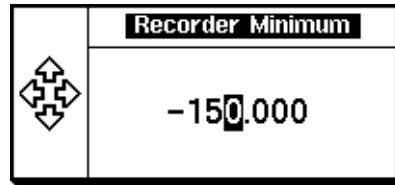

Figure 27 Recorder Minimum Pop-up

NOTE The highest power you are going to measure is used to determine the value which you should set for the Recorder Output maximum setting. For example, if you are measuring a power less than 1 mW and greater than 100 μ W, then set the recorder maximum value to 1 mW.

Log	50	40	30	20	10	0
Lin	100 W	10 W	1 W	100 mW	10 mW	1 mW
Log	-10	-20	-30	-40	-50	-60
Lin	100 μ W	10 μ W	1 μ W	100 nW	10 nW	1 nW

TIP If you have selected linear scaling for the analog measurement and the units you require are outwith the range of the displayed menu, an additional menu is available. When the pop-up is displayed, you can press

More to access the increment/decrement multiplier menu. Use the

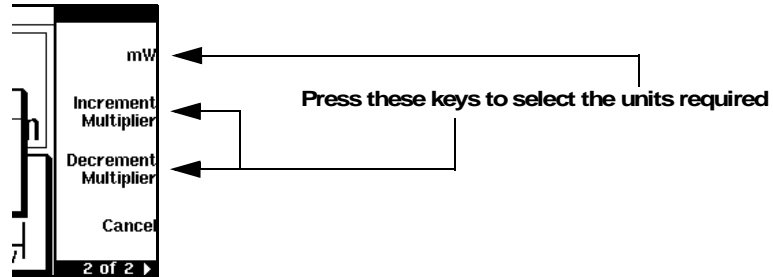

Increment Multiplier or **Decrement Multiplier** to display the required units. Press the units softkey (**xW**) to complete the entry.

Saving and Recalling Power Meter Configurations

To reduce repeated setup sequences, up to ten power meter configurations can be stored in non-volatile memory.

The save/recall functions are part of the **Sys/Inputs** menu, accessed by pressing the  key.



To save a measurement setup:

- 1 Press , **Save/Recall** to display the Save/Recall screen as shown in Figure 28.

RMT TLK			Save/Recall
Reg	Name	Status	
1	State1	Available	Save
2	State2	Available	
3	State3	Available	Recall
4	State4	Available	
5	State5	Available	Edit
6	State6	Available	Name
7	State7	Available	
8	State8	Available	Done
9	State9	Available	
10	State10	Available	
			1 of 1

Figure 28 Save/Recall screen

NOTE Your power meter has been shipped with measurement configurations suitable for common wireless communication formats already saved as Instrument States. These require E-series E9320 power sensors. Refer to chapter 3 for more information.

- 2 Using the  and  keys, select an available name from the displayed list. To change the name of a register, proceed from step 4, otherwise press **Save**.

- 3 The power meter prompts you to press **Confirm** to proceed.

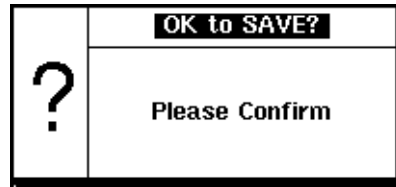

Figure 29 "Save" Pop-up

If you need to modify a name:

- 4 If you have not already done so, press **System**, **Save/Recall**.
- 5 Use the **Up** and **Down** keys to select the required register and press **Edit Name**. The selected name is displayed in a pop up window. Modify this as required:
- Use **Up** and **Down** keys to modify the character on which the cursor is currently positioned.
 - Use **Left** or **Right** to move to other characters.
 - Use **Insert Char** and **Delete Char** as required.
- 6 To confirm your choice press **Enter**.

To recall a measurement setup:

- 1 Press **System**, **Save/Recall**.
- 2 Use the **Up** and **Down** keys to select the required register and press **Recall**.

NOTE The **Recall** key is disabled (greyed out) when an unused register is selected.

3 Press **Confirm**.

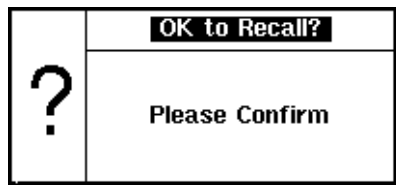

Figure 30 "Recall" Pop-up

Measuring Pulsed Signals

TIP The E-series E9320 power sensors are best suited for peak and pulse power measurement.

However, the E-series E9300 or 8480 series power sensors can be used to measure the power of a pulsed signal.

The measurement result is a mathematical representation of the pulse power rather than an actual measurement (assumes constant peak power). The power meter measures the average power of the pulsed input signal and then divides the measurement result by the duty cycle value to obtain the pulse power reading. The allowable range of values is 0.001 % to 100 %. The default value is 1.000%.

If duty cycle is enabled and the channel is setup in single numeric display format, the message **Dty Cyc** is displayed.

NOTE Pulse measurements are not recommended using Agilent E4412A and E4413A power sensors.

An example of a pulsed signal is shown in Figure 31.

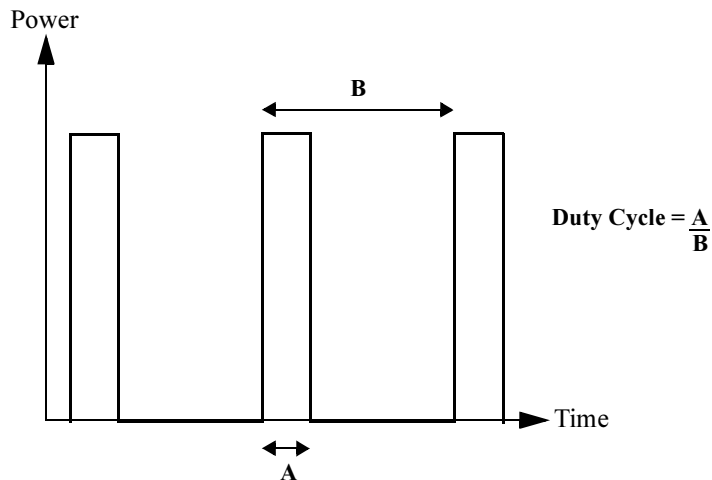











Figure 31 Pulsed Signal

Procedure Set the duty cycle as follows:

- 1 Press . Select the channel you want to configure. The current setting of the duty cycle is displayed in the channel setup table.
- 2 Use the , ,  and  keys to select the duty cycle setting and press **Change** to select **On**.

RMT TLK		Input Set
Channel Setup		Change
Sensor Mode:	AVG only	
Range:	AUTO	
Filter:	AUTO 128	Gates >
Duty Cycle:	Off 1.000%	
Offset:	Off 0.00000	Trace Setup >
Frequency:	947.00MHz	
CF Table:	Off	
FDO Table:	Off	
Video Avg:	Off 4	Done
Video B/W:	Med	
Step Detect:	Off	
		1 of 1

Figure 32 Duty Cycle: Off

- 3 Use the , ,  and  keys to select the duty cycle value and press **Change**.

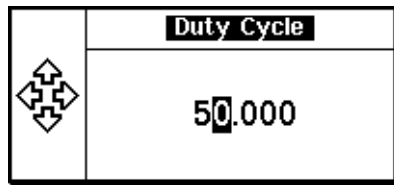

Figure 33 Duty Cycle Pop-Up

- 4 Again use the , , , and  keys to select and change the values as required. Complete the entry by pressing **%**.

LCL TLK		Input Set
Channel Setup		Change
Sensor Mode:	AVG only	
Range:	AUTO	
Filter:	AUTO 128	Gates▶
Duty Cycle:	On 50.000%	
Offset:	Off 0.000dB	Trace Setup▶
Frequency:	947.00MHz	
CF Table:	Off	
FDO Table:	Off	
Video Avg:	Off 4	Done
Video B/W:	Med	
Step Detect:	Off	
		1 of 1

Figure 34 Duty Cycle: On, 50%

- 5 Press **Done**.

NOTE Pulse power averages out any aberrations in the pulse such as overshooting or ringing. For this reason it is called pulse power and not peak power or peak pulse power.

In order to ensure accurate pulse power readings, the input signal must be pulsed with a rectangular pulse. Other pulse shapes (such as triangle, chirp or Gaussian) will cause erroneous results.

The pulse power on/off ratio must be much greater than the duty cycle ratio.

Presetting the Power Meter

This section details the power meter’s preset conditions.

The GPIB address, the data stored in the sensor calibration tables, and the zeroing and calibration data are not affected by a  (Preset). The calibration table selected is not affected.

Preset Conditions

The number of windows displayed is two.



- Select Interface** is not affected.
- GPIB Addr** is not affected.
- Baud Rate** is not affected.
- Word Size** is not affected.
- Stop bits** is not affected.
- Parity** is not affected.
- Pacing** is not affected.
- Echo** is not affected.
- Sensor Cal Tables** channel **Table** is not affected.
- Freq. Dep. Offset** channel **Table** is not affected.
- Linearity** is set to **Atype**.
- Power Ref** is set to **Off**.
- Must Cal** is not affected.



Sensor Mode:	Is active and set to Normal mode only when an E-series E9320A sensor is connected, otherwise inactive and greyed out in AVG only setting.
Range:	Is active and set to Auto only when an E-series E9320A or E-series E9300 sensor is connected, otherwise inactive and greyed out in Auto setting.
Filter:	Is set to Auto .
Duty Cycle:	Is set to Off . Is inactive and greyed out when an E-series E9320 sensor is connected and in <i>normal</i> mode.
Offset:	Is set to Off .
Frequency:	Is only available when an E-series sensor is connected and is set to 50.000MHz .
Cal Fac:	Is only available when an 8480 series sensor is connected and is set to 100% .
CF Table:	Is not affected when an 8480 series sensor is connected, otherwise inactive and greyed out in the Off setting.
FDO Table:	Is not affected.
Video Avg:	Is set to Off when and E-series E9320A sensor is connected otherwise greyed out in the Off setting.
Video B/W:	Is set to Off when and E-series E9320A sensor is connected otherwise greyed out in the Off setting.
Step Detect:	Is set to On .
Gates	Is only available when an E-series E9320A power sensor is connected.
Gate Start:	All gates are set to 0.0000 s .
Gate Length:	Gate1 is set to 100.00 μs . Gates 2, 3, and 4 are set to 0.0000 s .
Trace Setup	Is only available when an E-series E9320A power sensor is connected.
Start:	Is set to 0.0000 s .
Length:	Is set to 100.00 μs .
Max:	Is set to 20.000 dBm .
Min:	Is set to -50.000 dBm .
Min:	Is set to dBm .





All Trigger configurations are inactive and greyed out unless an E-series E9320A power sensor is connected.

Acqn	Is set to Free Run .
Stop Run	Is set to Run .
Source	Is set to Int .
Mode	Is set to AutoLvl .
Delay	Is set to 0.0000 s .
Slope	Is set to + .
Holdoff	Is set to 1.0000 μs .
Hysteresis	Is set to 0.000 dB .
Output	Is set to Off .



Chan, **Gate**, and **Meas** are all inactive and greyed out, regardless of sensor type.

Function	Is set to Single .
Rel	Is set to Off .
Rel	Is set to 0.000 dBm .
Offset	Is set to Off .
Offset	Is set to 0.000 dBm .
Limits	Is set to Off .
Max	Is set to 90.000 dBm .
Min	Is set to -90.000 dBm .
TTL Output	Is set to Off .

	Disp Type	Upper window is set to Single Numeric and the Lower window to Analog .
	Resolution	Is set to 3 .
	TTL Output	Is set to dBm .
	Freq	Is only available when an E-series power sensor is connected and is set to 50.000 MHz .
	Cal Fac	Is only available when an 8480 series sensor is connected and is set to 100% .
	Power Ref	Is set to Off .



3 Using E-Series E9320 Power Sensors

What You'll Find In This Chapter

This Chapter shows you how to use E-series E9320 power sensors with your EPM-P series power meter.

It contains the following sections:

- Introduction on page 90
 - Power Meter Configuration on page 92
 - Measurement Method on page 93
 - Configuring a Peak Power Measurement on page 96
 - Measurement Example on page 123
 - Using Pre-installed Measurement Setups on page 128
-

Introduction

The E-series E9320 power sensors have dual modes of operation.

- The *normal* mode is optimized for a wider bandwidth but with reduced dynamic range. The instantaneous power of an RF signal can be detected with, depending on the sensor type, up to 5MHz of video bandwidth (modulation bandwidth). Use this mode to measure the peak and average power of pulsed or modulated signals.
- The *average-only* mode is optimized for high accuracy and wide dynamic range. Use this mode to measure the average power of signals below the dynamic range of *normal* mode.

NOTE The term ‘video’ is applied here to a signal that has been amplitude demodulated from an RF carrier but contains components in the RF part of the spectrum. For a power meter it refers to the output of the sensor diodes in *normal* mode.

In *normal* mode the EPM-P series power meters and E-series E9320 power sensors continuously sample the RF signal at a 20 mega-samples per second rate. A trigger can be taken from a rising or falling edge of an RF signal pulse or controlled externally via GPIB or TTL input.

Table 8 Sensor Bandwidth

Sensor	Video Bandwidth Setting			
	Low	Medium	High	Off
E9321A E9325A	30 kHz	100 kHz	300 kHz	300 kHz *
E9322A E9326A	100 kHz	300 kHz	1.5 MHz	1.5 MHz *
E9323A E9327A	300 kHz	1.5 MHz	5 MHz	5 MHz *

* The Low, Medium, and High settings provide flat filter responses with very sharp cutoff points by applying digital signal processing techniques. The Off setting removes all signal conditioning. Refer to Figure 39.

NOTE Maximum dynamic range is related to the maximum sensor bandwidth. Please refer to the documentation supplied with your E-series E9320 power sensor for specification information.

Power Meter Configuration

The EPM-P series power meters automatically recognize an E-series E9320 power sensor when it is connected. The sensor calibration data, characterizing the sensor output versus input power, frequency, and temperature, is automatically read by the power meter.

Default Channel Setup

When an E-series E9320 power sensor is connected the following **Channel Setup** is automatically configured. Carrying out a Preset returns the power meter to this configuration.

Any changes made to the **Channel Setup** are retained after a power cycle.

RMT TLK	Input Set
Channel Setup	
Sensor Mode: Normal	Change
Range: AUTO	
Filter: AUTO 256	Gates ▶
Duty Cycle: Off 1000%	
Offset: Off 0.00000	Trace Setup ▶
Frequency: 50.000MHz	
CF Table: Off	
FDO Table: Off	Done
Video Avg: Off ◀	
Video B/W: Off	
Step Detect: On	1 of 1

Figure 35 E-series E9320 power sensor default Channel Setup

Measurement Method

The E4416A meter and E-series E9320 power sensors continuously sample the RF signal at a 20 MHz rate. Similarly, the E4417A samples both channels at the same rate. Various trigger methods enable the measurement of continuously modulated signals or single events.

Measurement Gates

A system of gates, controlled by and referenced to a trigger point, is used to extract measurement data from the captured trace. The trace data within each gate period is subsequently used for the individual measurement calculations. Up to 4 gates can be set up for each channel (Refer to Figure 36.)

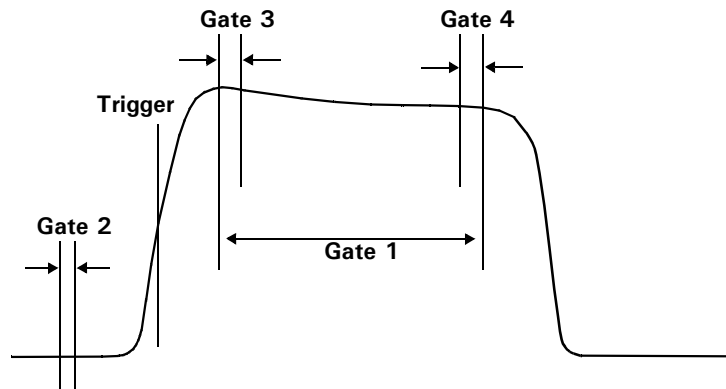

Figure 36 Measurement Gates

With the gates setup as shown in Figure 36 for example, you can simultaneously measure:

- The average power level of the pulse: Gate 1, average measurement
- The Peak to average ratio: Gate 1, peak-to-average measurement
- The Pulse droop: Gate 3, average measurement, minus Gate 4, average measurement
- The average “off” power level ahead of the pulse: Gate 2, average measurement.

Measurement Display

Average, peak, and peak-to-average ratio measurements are made within each gate period generating 12 possible measurement results per channel as shown in Figure 37.

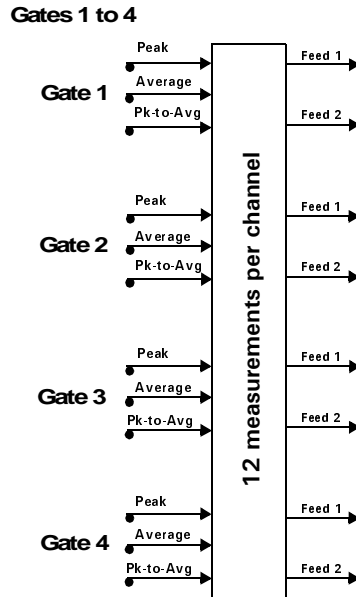
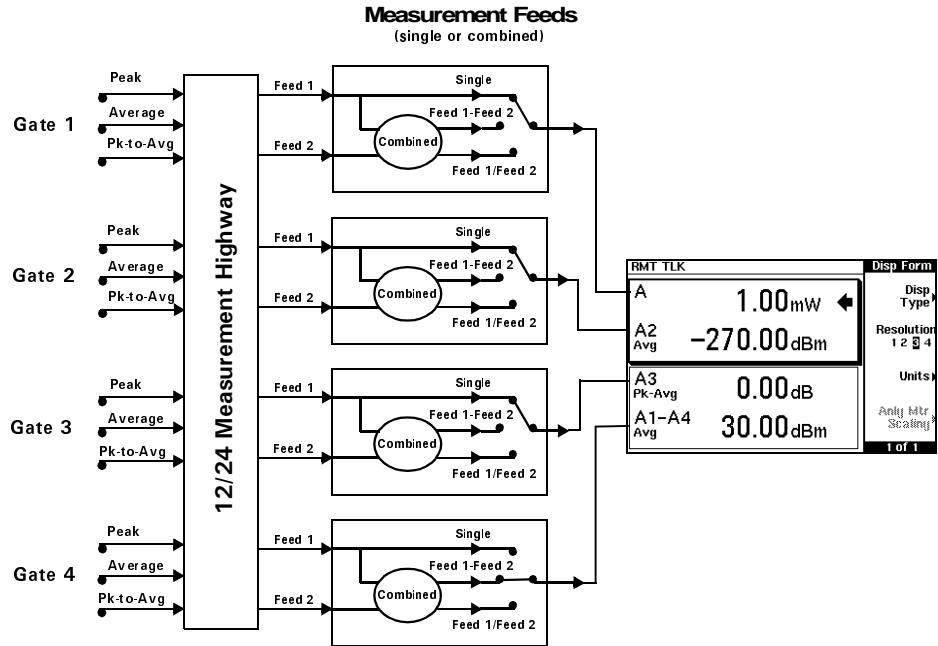

Figure 37 Twelve Measurements per Channel

The EPM-P power meters cannot display all 12 (or 24) measurements simultaneously. However, up to 4 measurements or a combination of measurements and traces can be shown on the display. Any of the 4 measurement display lines can show any of the measurement results from any of the 4 gates allowing you complete control of the displayed information.



Each displayed line has a measurement feed. Each measurement feed has two independent inputs, Feed 1 and Feed 2. The two Feeds, 1 and 2, can carry any of the 12 measurement results from the 4 gates. (24 measurements from 8 gates in the dual channel E4417A.) Only Feed 1 can be displayed in Single Mode. In Combined Mode, Feed 1 - Feed 2 or Feed 1 / Feed 2 can be displayed.

NOTE When selected, the trace display should be used only as an indication. It is representative of the measurement trace but the resolution is constrained by the limitations of the display.

You can configure the trace start and length parameters in a similar manner to setting up a gate. In addition, you can configure the amplitude scaling.

Configuring a Peak Power Measurement

While the EPM-P may at first seem complex, configuring a measurement and displaying the results are quickly achieved using trace markers or by following a step-by-step process of numeric data entry.

Before configuring the measurements, you should have some information about the signal you want to measure. The following information for example, can help you quickly establish stable triggering and reliable measurement data:

- the Center Frequency (CF)
- the bandwidth of any modulating signal
- the expected maximum and minimum power levels
- timing information for any pulsed signals

You can configure the required measurements using numeric data entry from the keypad or remote interface or, by manually positioning trace markers using the front panel controls.

Setting up the power meter using the trace markers is a more interactive process and may require more iterations between channel, triggering, gate, and display functions to make a measurement. However, it is ideally suited to measuring an unknown signal.

TIP If pulsed signal timing information is unavailable or incomplete, you may prefer to use the trace and marker functions to configure your measurement.

NOTE You must select continuous or single triggered mode to enable the use of trace markers.

The Set Up Process





Setting Up Using Data Entry

Using the data entry method, the following steps are required to set-up one or several measurements.

- 1 Channel Setup** - choose the sensor mode and range, configure filtering, averaging, bandwidth, and the RF frequency.
- 2 Gate Setup** - configure the timing of gates for the signal you want to measure.
- 3 Trigger Setup** - configure the trigger to ensure the gates you have set up are capturing the required signal information.
- 4 Display Setup** - choose the display format for the measurements you want to make.
- 5 Measurement Setup** - assign the measurements to the displays you have set up.

Step 1. The Channel Setup

- Press .

The **Channel Setup** screen is displayed. Select the channel you want to configure and use the , , , and  keys to select any parameters you want to change. Press **Change** to configure the required settings.

RMT TLK	Input Set
Channel Setup	
Sensor Mode:	Normal
Range:	AUTO
Filter:	AUTO 256
Duty Cycle:	Off 1000%
Offset:	Off 0.000dB
Frequency:	50.000MHz
CF Table:	Off
FDO Table:	Off
Video Avg:	Off
Video B/W:	Off
Step Detect:	On
	Change
	Gates
	Trace Setup
	Done
	1 of 1

Figure 38 E-series E9320 power sensor default Channel Setup

Sensor Mode: **Normal** enables peak, peak-to-average, and average measurements and is suitable for making time gated measurements. **AVG only** is suitable for measuring the average power of a lower level signal only. If used above -20 dBm it will give accurate results for CW signals only.

Range: The power sensors have a high and low range. When in autoranging mode, the correct range for the measurement is selected automatically. In Free Run acquisition mode the range is selected to be suitable for the input signal. If the signal rises sharply through a range threshold while a measurement is being made the range is changed and a new measurement made. In a triggered acquisition mode, (**Cont Trig** or **Sing Trig**) the sensor may switch range from low to high on the rising edge of a pulse, or from high to low on the trailing edge. The time delay for this process, $4 \mu\text{s}$ with

Video B/W set to **Off**, 8 μ s using **High**, **Med**, and **Low** settings, may impair your measurement. By using the upper or lower settings to hold the sensor in a specific range, the switching delay is removed.

Filter: The power meter uses a digital filter to average power readings. The filtering is applied only to an average measurement in the selected gates when in *normal* mode or to the *average-only* mode measurement. The number of readings averaged can range from 1 to 1024. This filter is used to reduce noise, obtain the desired resolution and to reduce the jitter in the measurement results. Increasing the value of the filter length reduces measurement noise but increases the time to make the measurement.

Offset: If your test setup has known gains or losses, you can remove these from the displayed measurement results by setting up an Offset as described in Setting Offsets on page 53.

Frequency: The E-series E9320 power sensors are fully corrected for calibration factor and frequency dependent linearity errors. Correction data is downloaded to the meter when a sensor is connected. It is important, for best accuracy, to enter the frequency of the RF signal you are measuring.

TIP Entering the frequency, especially when making comparative measurements between signals, greatly reduces measurement uncertainty.

FDO Table: If your test setup has known frequency dependant amplitude variations, you can remove these errors from the displayed measurement results by setting up and using a Frequency Dependant Offset table. Refer to Setting Offsets on page 53.

Video Avg: Video averaging uses a digital filter to average to average repetitions of a triggered signal. The number of acquisitions averaged can range from 1 to 256. With video averaging the average of a number of acquisitions is calculated to smooth the displayed

trace and reduce apparent noise. The measurement requires a continuously repeating signal. Increasing the value of the filter reduces noise but increases the time required to make the measurement.

Video B/W:

Select a value close to or greater than that of the modulating signal bandwidth. Note that this varies between sensors (See Table 8 on page 90). The pass band shapes achieved by the video bandwidth settings are flat with very sharp cutoffs to ensure accurate power measurement within the specified band.

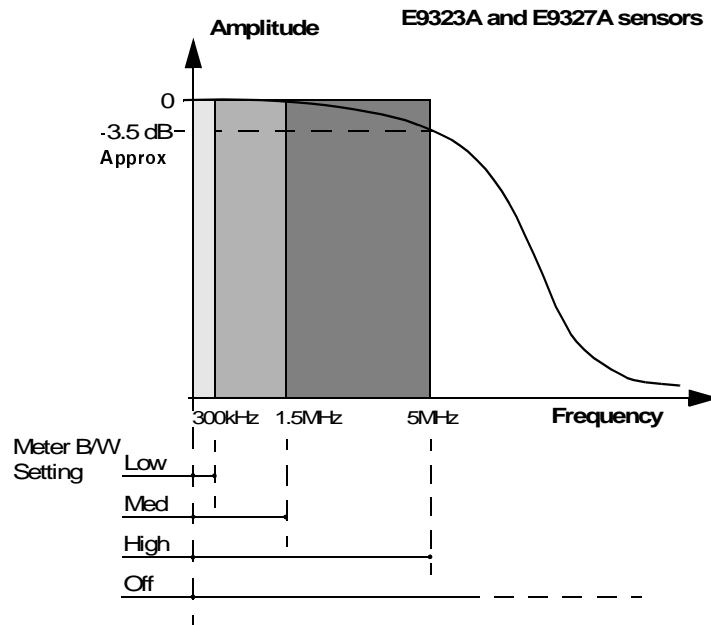

Figure 39 Bandwidth Filter Shapes

A fourth, filter Off, setting is provided. This provides approximately 3dB roll off at the maximum sensor bandwidth and is best suited for accurate trace capture, removing any ringing effects caused by the sharp cut-off filters used in the Low, Med and High settings. Figure 39 shows the filter shapes associated

with the E9323A and E9327A power sensors. Table 8 on page 90 lists all the bandwidth settings. Selecting a bandwidth only slightly higher than required by your signal can help reduce noise and improve accuracy on peak measurements. It can however, reduce the processing speed for long acquisition times.

Step Detect: To reduce the filter settling time after a significant step in the measured power the filter can be set to re-initialise upon detection of a step increase/decrease in the measured power. Step detection can be set in both manual and automatic filter modes.





Step 2. The Gate Setup

- Press **Gates**.

The **Channel Gates** screen is displayed.

RMT TLK	Gates
<u>Channel Gates</u>	
Gate1 Start: 0.000 s	Change
Length: 100.0us	Zero Value
Gate2 Start: 0.000 s	Gate Control
Length: 0.000 s	Done
Gate3 Start: 0.000 s	
Length: 0.000 s	
Gate4 Start: 0.000 s	
Length: 0.000 s	
	1 of 1

Figure 40 Gates screen

- First select the **Gate Start** value for the gate you want to configure using the , , , and  keys.

NOTE The gate start time is relative to the trigger event. Positive values open a measurement gate up to 1 second after the trigger. Use a negative Time Gate Start value to open a gate up to 1 second before the trigger.

- Press **Change** and again use the , , , and  keys to configure the required value in the **Time Gating Start** pop-up window.

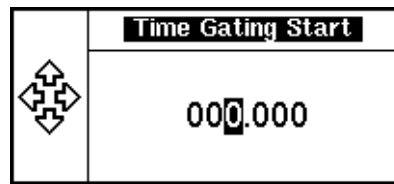





Figure 41 Time Gating Start pop-up

- Complete the entry by pressing the required second, millisecond, or microsecond (**s**, **ms**, or **us**) keys.

- Select the **Gate Length** parameter and press **Change**. Use the , , , and  keys to configure the required value in the **Time Gating Length** pop-up window. A maximum of 1 second can be entered.

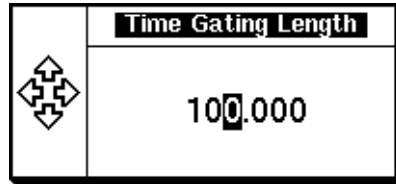

Figure 42 Time Gating Length pop-up

- Complete the entry by pressing the required second, millisecond, or microsecond (**s**, **ms**, or **us**) softkey.
- Repeat this process until you have setup all the required gates.

NOTE The gate length is the length of time from the gate start. It can only have positive values.

Step 3. The Trigger Setup

- Press .

The **Trigger** menu is displayed. (The **Trigger** menu is disabled when the **Sensor Mode** is set to **AVG only** in the **Channel Setup**.)

The trigger status is also displayed below the **Acqn** label in the **Trigger** menu. Figure 43 shows the power meter display in Free Run mode. In this mode the meter is not synchronized to any modulated RF signal at the sensor input. Consequently, power levels within the configured time gates are random and the displayed measurement results are not valid.

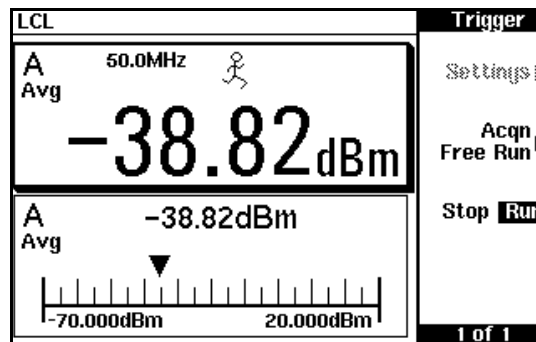





Figure 43 Trigger menu - Free Run Mode

NOTE The  symbol in the upper window indicates the power meter is in free run mode. The  symbol is replaced by  and the measurement halted when **Stop Run** is pressed to select **Stop**.

To make use of the measurement gates the power meter must be triggered. The trigger can be taken from a rising or falling measured power level or controlled externally via the Ext Trig input or GPIB. Additional features such as hold-off, hysteresis, and delay are additional control features provided to help you achieve a stable and reliable trigger.

- Press **Acqn** to configure a trigger.
 - Select either **Sing Trig** or **Cont Trig**. **Sing Trig** is a single shot mode. After triggering, the measurement is halted, the **⊗** symbol is displayed and **Stop** is highlighted. You can start another measurement by pressing **Stop Run** to select **Run**, and wait for the next trigger.
- Press **Settings** to configure the remaining trigger parameters.

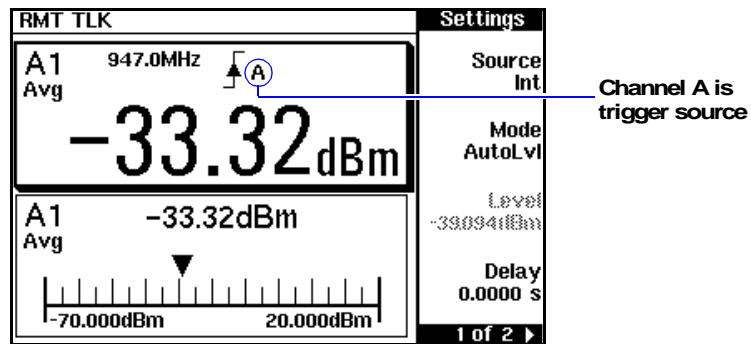

Figure 44 Trigger Setting Menu 1 of 2

There are 2 pages for the trigger Settings menu. Figure 44 shows page 1.

TIP To help you quickly check the triggering setup the current settings for all the trigger parameters are shown below the respective softkey labels.

Source

The current setting is shown below the **Source** label. Also, the trigger source is shown beside the trigger symbol when a measurement window is configured in single numeric mode. When an external trigger (**Ext**) is selected, the power meter can be triggered via the Ext Trig (TTL transition edge) input or a remote command.

To change the setting press **Source** and choose **Ext** or **Int**.





Mode

The **Mode** key is only available when trigger **Source Int** is selected. Again, the current setting is displayed

below the label. When **Norm** is selected you can choose the RF power level transition used as the trigger. The power meter automatically finds a triggering power level transition when **AutoLvl** is selected.

To change the setting press **Mode** and choose **Norm** or **AutoLvl**.

Level

Level is only available when **Norm** trigger has been selected. The current value is shown below the **Level** label. The minimum power level you can enter is limited to 40 dB below the maximum sensor power. To change the setting press **Level** and use the , , , and  keys to enter the new value.

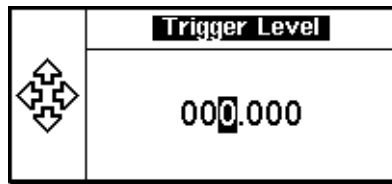





Figure 45 Trigger Level Pop-up

Complete the entry by pressing **dBm**.

Delay

The current setting is displayed below the **Delay** label. The delay time is applied between the trigger event and all the gate start times. This allows you to time-shift all the gates by the same amount with one setting change. A delay of up to 1 second can be entered. To change the setting press **Delay** and use

the , , , and  keys to enter the new value.

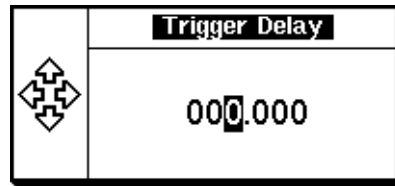



Figure 46 Trigger Delay Pop-up

Complete the entry by pressing **s**, **ms** or **us**.

Press  to display the second menu page.

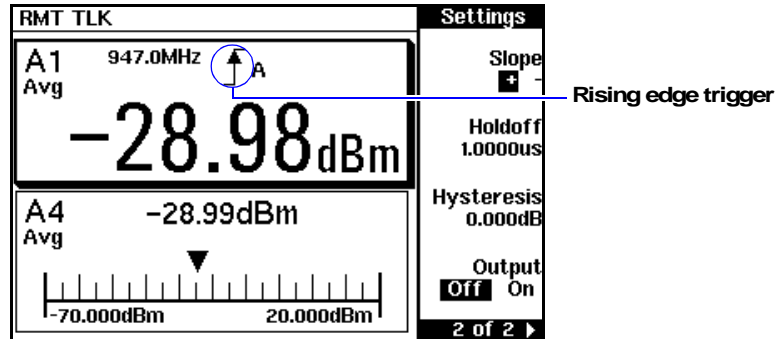





Figure 47 Trigger Setting Menu 2 of 2

Slope

The current setting is displayed below the **Slope** label and the  or  symbol is displayed in single numeric display mode. **+** (and ) is used to generate the trigger from an increasing power level. Similarly, **-** (and ) is used to generate the trigger from a decreasing power level or external TTL transition. To change the setting press **Slope** to highlight **+** or **-** as required.

Holdoff

The current setting is displayed below the **Holdoff** label. After a trigger event occurs, the trigger mechanism is disabled for the configured time period.

This allows stable triggering to be achieved even when a signal has multiple edges, for example, a TDMA signal with non-constant amplitude modulation. Values up to 400 ms can be configured.

To change the setting press **Holdoff** and use the , , and  keys to enter the new value.

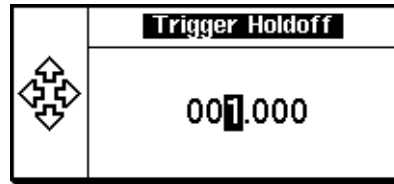

Figure 48 Trigger Hold off Pop-up

Complete the entry by pressing **s**, **ms**, or **us**.

Hysteresis

The current setting is displayed below the **Hysteresis** label. You can use the hysteresis function to help generate a more stable trigger by preventing triggering unless the RF power level achieves the trigger level and the additional hysteresis value. It can be applied to both rising and falling edge trigger generation. A maximum of 3 dB hysteresis can be entered.





Rising edge:

When a rising power transition triggers the power meter, the triggering system is disabled. The power meter does not trigger again if another rising power transition is presented. The triggering system is rearmed only when the input power falls below a level equal to the trigger level minus the configured hysteresis value.

Falling edge:

When a falling power transition triggers the power meter, the triggering system is disabled. The power meter does not trigger again if another falling power transition is presented. The triggering system is rearmed

only when the input power rises above a level equal to the trigger level plus the configured hysteresis value.

To change the setting press **Hysteresis** and use the , , , and  keys to enter the new value.

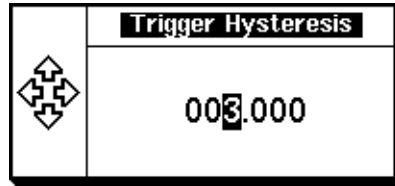

Figure 49 Trigger Hysteresis Pop-up

Complete the entry by pressing **dB**.

Output

The current setting is displayed below the **Output** label. A TTL level high is produced at the rear panel TRIG OUT BNC connector when the power meter is triggered when **On** is configured.

To change the setting press **Output** to highlight **On** or **Off** as required.

Step 4. The Display Setup

This step requires that you first check the power meter is set up to show the measurement results in the display format you require.

- Press , **Disp Type** to display the first page of the display format menu.

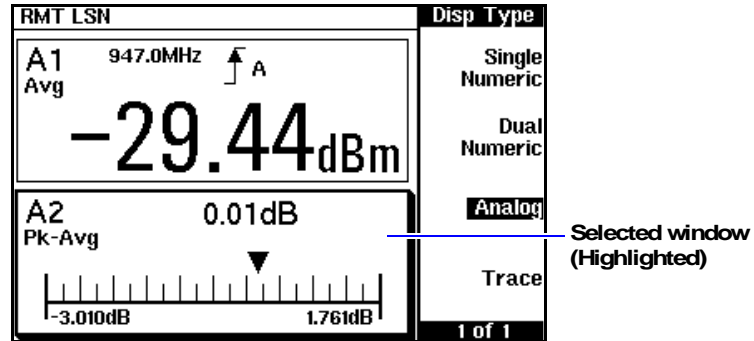



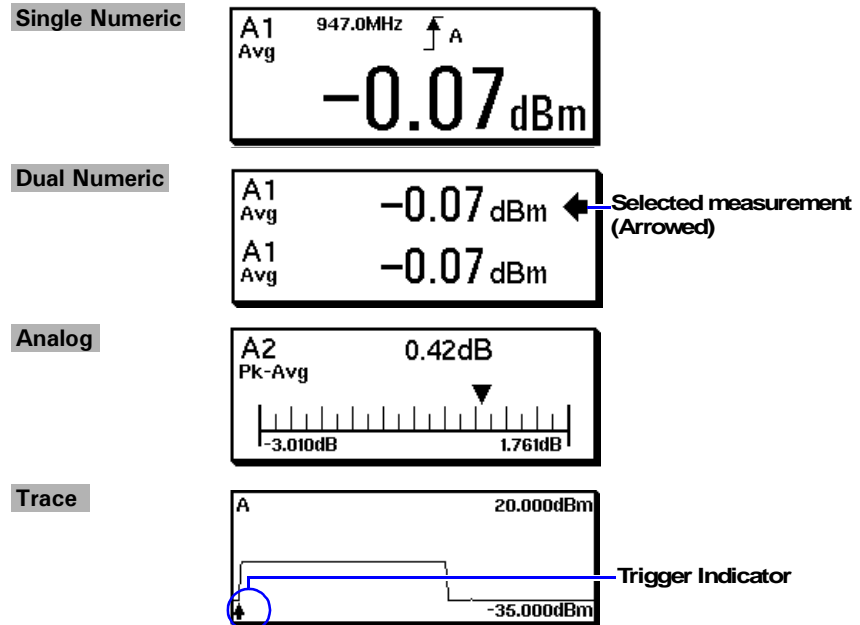

Figure 50 Display Type Menu



- Use the , , or  keys to select a measurement window. Choose the type of display you require from the menu.



Step 5. The Measurement Setup

Numeric Format

Configure a measurement displayed in **Single Numeric** or **Dual Numeric** format as follows:

- Press **Meas Setup** and use the , , or  keys to select the measurement window or measurement line you want to configure.
- Press **Meas Select**.

RMT LSN			Meas Sel
Lower Window / Lower Measurement			Change
	Chan	Gate	Meas
Feed:	A	1	Avg
Relative:	Off	0.000dBm	0.000dB
Offset:	Off	0.000dB	0.000dB
			Combination Feed1/Feed2
			Done
			1 of 1

Figure 51 Lower Window/Lower Measurement Setup

Single Function Measurement







- Press **Function** to select **SINGLE**.
- Use the , , , , and **Change** keys to assign a measurement type to a gate number as required.

Figure 51 shows an average measurement assigned to Gate 1 in the lower measurement line of the lower window. (The Channel label is disabled as a single channel meter is shown.)

- Press **Done** to complete the set-up and display the measurements results screen.
- Use the , , or  keys to select the next measurement window or measurement line you want to configure.

Combined Measurement

- Press **Function** to select **COMB**.
- Use the **←**, **→**, **↑**, **↓**, and **Change** keys to assign a measurement type to a gate number as required.

Figure 52 shows a Combined Measurement configuration; channel A, gate 1 peak power minus gate 3 peak power, with a 3dB display offset, to be displayed in the upper measurement line of the lower display window. (Again, the Channel label is disabled as a single channel meter is shown.)

RMT TLK			Meas Sel
Lower Window / Upper Measurement			Change
	Chan	Gate	Meas
Feed1:	A	1	Peak
Feed2:	A	3	Peak
Relative:	Off	0.000dB	
Offset:	On	3.000dB	
			Function COMB
			Combination Feed1-Feed2
			Done
			1 of 1

Figure 52 Measurement set-up example

- Press **Done** to complete the setup. The measurement configuration is also displayed with the results. Figure 53 shows both the previously configured measurements in the Lower Window.

A1-A3 Peak	-33.74dBm ←
A1 Avg	-0.03dBm

Figure 53 Measurement example display

Continue this process until you have configured all the required numeric displays.

Analog Format

Configure a measurement displayed in **Analog** format as follows:

- Press **Meas Display**.
- Use the **▲**, **▼**, or **↕** keys to select the analog measurement window.
- Press **Anlg Mtr Scaling**.

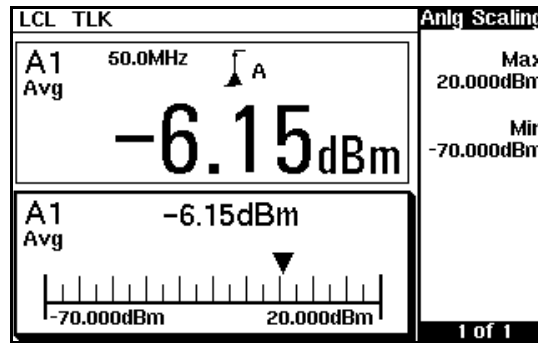

Figure 54 Analog display in lower window

The **Max** and **Min** scale values are shown on the analog display and adjacent to the softkey labels.

- Press **Max** and use the **◀**, **▶**, **▲**, **▼** keys to configure the required value in the **Meter Maximum** pop-up window. Press **dBm**, **mW**, **uW**, or **nW**, to complete the entry.

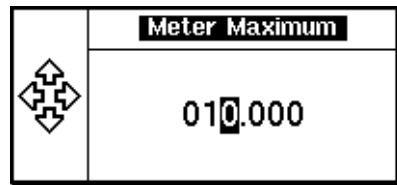





Figure 55 Meter Maximum Pop-up

- Similarly, press **Min** and use the , , ,  keys to configure the required value in the **Meter Minimum** pop-up window. Press **dBm**, **mW**, **uW**, or **nW**, to complete the entry.

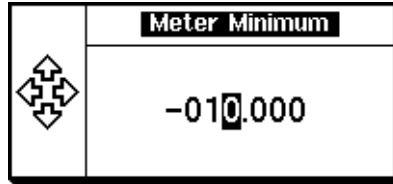

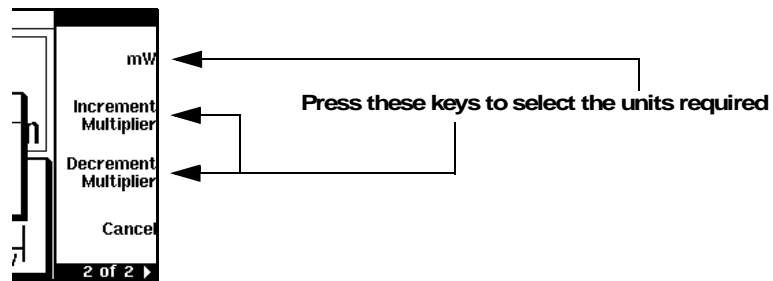



Figure 56 Meter Minimum Pop-up

TIP If you have selected linear scaling for the analog measurement and the units you require are outwith the range of the displayed menu, an additional menu is available. When the pop-up is displayed, you can press  to access the increment/decrement multiplier menu. Use the



Increment Multiplier or **Decrement Multiplier** to display the required units. Press the units softkey () to complete the entry.

Trace Format

Configure a measurement displayed in **Trace** format as follows:

- Press **Meas Display** and use the **←**, **→**, **↑**, **↓**, or **↕** keys to select the trace window.
- Press **Channel**, **Trace Setup** to display the Trace Setup menu.

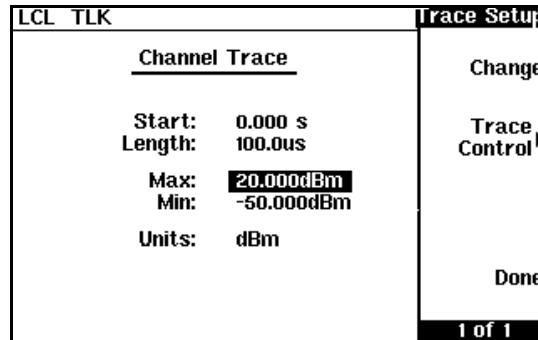

Figure 57 Trace display in lower window

- Use the **←**, **→**, **↑**, **↓** keys to select the required parameter.
- Press **Change** and configure the required value in the pop-up window. Press **dBm** to complete the entry.

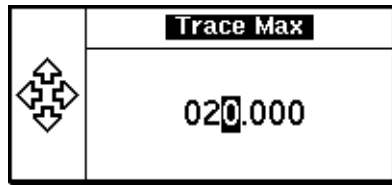

Figure 58 Trace Maximum Pop-up

- Similarly, select each parameter as required, completing the entry by pressing the appropriate units key.

NOTE The trace start time is relative to your selected trigger point. Positive values start the trace up to 1 second after the trigger event. Use a negative value to start the trace up to 1 second before the trigger.

Setting Up Using Trace Markers

Setting up a measurement using the trace markers requires less information about the signal you are measuring than the data entry method. Similar steps are required but in a different and less ordered manner. More iteration between the power meter controls may be required to complete the measurement set up.

While you can configure the display with several measurement results, there are some occasions where the information presented, as shown in Figure 59, is sufficient and additional display set ups are not required.

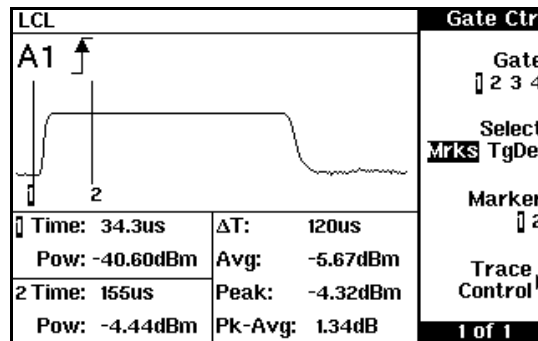



Figure 59 Gate Control Menu and Display

NOTE If the bandwidth of a modulated signal is unknown you may discover, during the set up process, that a power sensor of lesser or greater bandwidth is required.

Loosely follow this process until you are familiar with the trace and marker controls.

- Channel - choose the sensor mode and range, configure filtering, averaging, bandwidth, and the RF frequency.
- Trigger - configure the trigger to ensure the meter is triggering on the required event.
- Gate - use the **Gate Ctrl** and **Trace Ctrl** menus to configure the timing of gates and trigger point on the displayed signal.
- Display - choose the display format for the measurements you want to make.
- Measurement Setup - assign the measurements to the displays you have set up.

Channel Press . Refer to “Step 1. The Channel Setup” on page 98 and configure the **Channel Setup** table with as much information as you have available. Confirm the **Video B/W:** and **Video Avg:** are set to **Off**. Bandwidth, filtering, and averaging can be re-adjusted later to improve measurement accuracy.

RMT TLK	Input Set
Channel Setup	
Sensor Mode: Normal	Change
Range: AUTO	Gates ▶
Filter: AUTO 256	Trace Setup ▶
Duty Cycle: Off 1000%	Done
Offset: Off 0.0001dB	
Frequency: 50.000MHz	
CF Table: Off	
FDO Table: Off	
Video Avg: Off 4	
Video B/W: Off	
Step Detect: On	1 of 1

Figure 60 E-series E9320 power sensor default Channel Setup

NOTE The **Sensor Mode:** must be set to **Normal** to allow access to the gate and trace control screens.

Trigger The power meter must be in a triggered mode to allow access to the gate and trace control screens.

Press  and refer to “Step 3. The Trigger Setup” on page 104 to configure a suitable trigger. You can also configure trigger delay timing using markers.

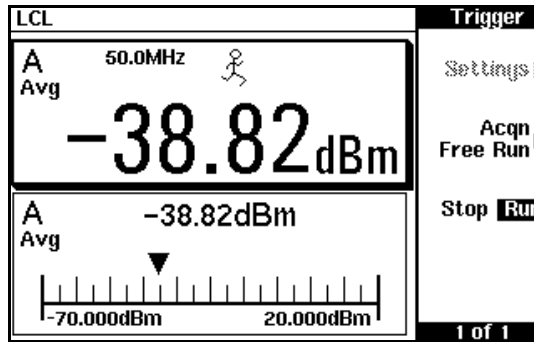

Figure 61 Trigger menu - Free Run Mode

Gate To access the gate control menu press **Channel**, **Gates**, **Gate Control**.

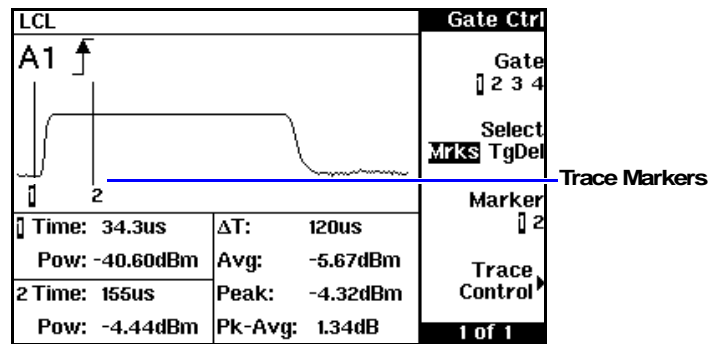

Figure 62 Gate Control Menu and Display

- Gate** Pressing **Gate** scrolls through the 4 gates available for each channel. The gate displayed is highlighted below the **Gate** softkey and also in the channel/gate annotation in the top left of the display.
- Select** Pressing **Select** displays the gate or trigger markers.
- Mrks** When **Mrks** is selected, markers **1** and **2** indicate the start and end points of the measurement gate.
- Tgdel** When **TgDel** is selected you can adjust the trigger delay. Again, refer to “Step 3. The Trigger Setup” on page 104 for more detail.

NOTE Your chosen trigger point is used as the reference point for the timing of all the measurement gates

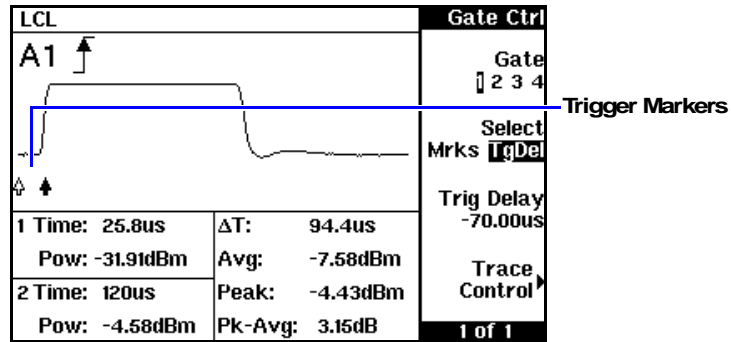

Figure 63 Trigger Marker - Negative Delay

Pressing the and hardkeys decreases or increases the trigger delay. Your chosen trigger point is indicated by . The trigger event is indicated by .

The configured value is displayed below the **Trig Delay** softkey.

Trig Delay



The trigger delay value is shown below the **Trig Delay** softkey.







You can also setup the trigger delay by pressing **Trig Delay** and entering a value in the pop-up window.

Pressing **Select** highlights **Mrks** to display the trace markers again.

Marker 1 2

Press **Marker** to select the required marker. Press the and hardkeys to move the selected marker.

NOTE Gate and trigger markers are moved one pixel when the  or  keys are pressed and released. They are moved up to 5 pixels at a time when the keys are pressed and held. To reduce the time interval represented by one pixel, decrease the length of the displayed trace.

Trace Control Press **Trace Control** to display the **Trace Ctrl** menu. The vertical and horizontal parameters of the displayed trace are shown in a table. The , , , and  keys are used to select a parameter. Use the  or  softkeys to increase or decrease the selected parameter. Position and scale the trace display as required to ease setting up the gate markers.

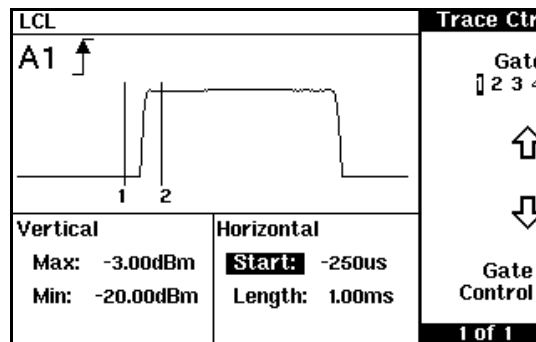



Figure 64 Trace Control Display

TIP To zoom in on a gate, first adjust the **Start:** parameter to place the gate markers at the left of the display. Next reduce the value of the **Length:** parameter. Re-adjust the **Start:** parameter as required. As the marker timings are related to the trigger point, they remain in a fixed position on the trace. Adjustments to the gate markers require the **Gate Ctrl** menu.

Gate Control Press **Gate Control** to display the **Gate Ctrl** screen and continue with the gate setup.

Repeat this process until you have configured all the gates required.

Display Now configure the display to show the measurement results you require by pressing . Refer to “Step 4. The Display Setup” on page 110 for more information.

TIP If you choose to configure one of the windows with a trace display, you can quickly re-display the **Gate Ctrl** screen by pressing .

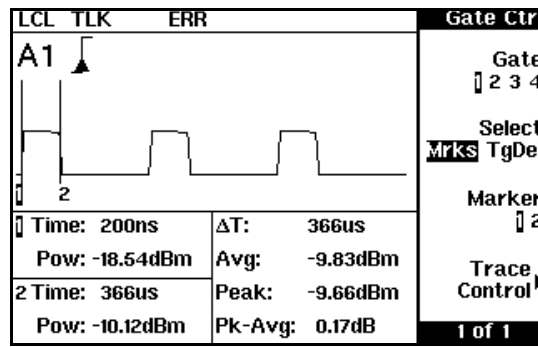

Figure 65 Bluetooth Signal with Markers Shown

Measurement Setup When you have configured both windows with the required displays, set up the measurements as shown in “Step 5. The Measurement Setup” on page 111.

Measurement Example

This measurement example configures the power meter to measure an Enhanced Data for Global Evolution (or Enhanced Data for GSM Evolution) signal. Triggering is achieved using the rising edge of the burst. As the power meter triggers during the rising power transition, the measurement gate is configured to measure the average power in a 520 μs period, 20 μs after triggering. The display is configured to show the peak and peak-to-average results in the lower window in numeric format, while the upper window shows the power trace starting 40 μs before the trigger.

Step 1. The Channel Setup





1. Press . The **Channel Setup** screen is displayed.
2. Select the channel you want to configure.
3. Use the , , , , and **Change** keys to configure the settings listed in Table 9.

Table 9 Measurement Example Channel Setup

Parameter	Setting
Sensor Mode:	Normal
Range:	AUTO
Filter:	AUTO
Offset:	Off
Frequency:	900 MHz
FDO Table:	Off
Video Avg:	Off
Video B/W:	E9321A *, E9325A * - High E9322A, E9326A - Med E9323A, E9327A - Low
Step Detect:	On

* The E9321A and E9325A sensors are best suited as they have the optimum dynamic range and low-level stability in the 300 kHz bandwidth.

NOTE After a Preset, **Video B/W** defaults to **High** for all sensors.

Step 2. The Gate Setup

Only one gate is to be set up, starting 20 μs after the trigger for a duration of 520 μs .





1. Press **Gates**. The **Channel Gates** screen is displayed.
2. Use the , , , , and **Change** keys to configure the settings listed in Table 10.

Table 10 Measurement Example Gate Configurations

Parameter	Setting
Gate1 Start:	20 μs
Length:	520 μs
Gate2 Start:	0
Length:	0
Gate3 Start:	0
Length:	0
Gate4 Start:	0
Length:	0















Step 3. The Trigger Setup

The trigger is now configured for a power level of -20 dBm on a rising edge. A trigger hold off is also setup for 4275 μ s, disabling the trigger and ensuring the same time slot is measured at the next frame. Also, trigger hysteresis is included to prevent small power transitions during the burst causing re-triggering.

Configure the Trigger as shown in Table 11.







Table 11 Measurement Example Trigger Configurations

Parameter	Setting
Acqn:	Cont Trig
Source:	Int (internal)
Trigger Level:	-20 dBm
Slope:	+ (rising)
Holdoff:	4275 μ s
Hysteresis:	3.0 dB
Output:	Off

1. Press . The **Trigger** menu is displayed.
2. Press **Acqn**, **Cont Trig**.
3. Press **Settings**, **Source**, **Int**.
4. Press **Mode**, **Norm**.
5. Press **Level**. Use the , , , and  keys to set the trigger level to -20 dBm.
6. Press  to access the second page of the menu.
7. Press **Slope** to select **+**.
8. Press **Holdoff**. Use the , , , and  keys to enter a value of 4275 μ s.
9. Press **Hysteresis**. Use the , , , and  keys to enter a value of 3 dBm.



















Step 4. The Display Setup

Before configuring the measurement, first setup the display for a dual numeric window and a trace window. Configure the Display as follows:

1. Press . The **Disp Form** menu is displayed.
2. Use the , , or  keys to select the upper window.
3. Press **Disp Type**, **Trace**.
4. Use the , , or  keys to select the lower window.
5. Press **Dual Numeric**.

Step 5. The Measurement Setup

The dual numeric window is now configured to display the average power, and the peak-to-average ratio, in gate 1. The trace window is configured to show the RF burst from 20 μ s ahead of the trigger for a duration of 700 μ s. Configure the Measurements as follows:

1. Press .
2. Use the , , or  keys to select the upper measurement in the lower window.
3. Press **Meas Select**. Use the , , , and  keys to setup an average measurement in Gate 1.
4. Press **Done**.
5. Use the , , or  keys to select the lower measurement in the lower window.
6. Press **Meas Select**. Use the , , , and  keys to setup a peak-to-average measurement in Gate 1.
7. Press **Done**.
8. Press .
9. Use the , , or  keys to select the upper window.

10. Press **Channel**, **Trace Setup** and setup the parameters as follows:

Table 12 Trace Setup Parameters

Parameter	Setting
Max	+ 20 dBm
Min	-35 dBm
Start	-40 μ s
Length	700 μ s

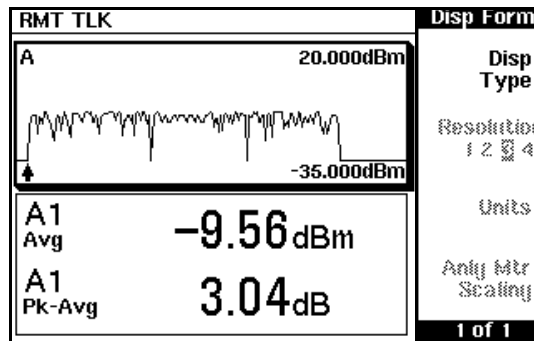

Figure 66 Measurement Example Measurement Display

TIP If you require faster measurement speed, set the **Filter:** to **MAN** (Channel Setup screen) and reduce the filter value. Conversely, if you are measuring low power levels and want to improve the stability of the measurements, increase the filter value. Increasing the filter value however, reduces the measurement speed.

The maximum power level for the E-series E9320 power sensors is +20 dBm. Attenuation may be required when directly measuring transmitter output. Enter the value of the attenuation as an **Offset:**

Press **Meas Setup**, **Meas Select** to correct the displayed measurement result.

Using Pre-installed Measurement Setups

Pre-installed measurement setups for GSM900, EDGE, NADC, iDEN, Bluetooth, cdmaOne, W-CDMA, and cdma2000 help reduce the time required to measure these common wireless communications formats.

They are accessed quickly by pressing the  key and using the cursor keys to select the required format from the displayed list.

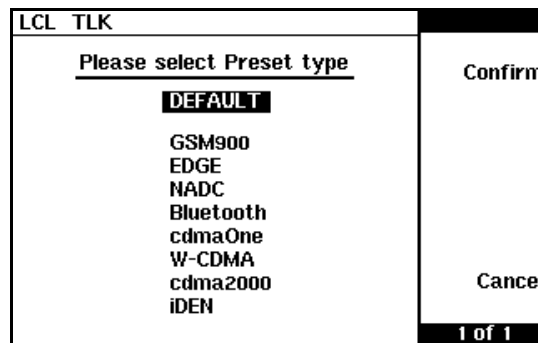



Figure 67 Preset Selection Display

If required, you can modify the setups to suit your own needs and save them using [Saving and Recalling Power Meter Configurations](#) on page 79.

NOTE

- When there are no power sensors connected, or sensors other than E-series E9320 power sensors, the pre-installed setups menu keys are disabled.
- When an E-series E9320 power sensor and a non E-series E9320 power sensor are connected to a dual channel meter, only the channel connected to the E-series E9320 power sensor is configured. The other channel is configured with default settings.
- When two E-series E9320 power sensors are connected to a dual channel meter, both channels are configured with the same values, differing only when the desired bandwidth requires an appropriate setting for each sensor.

Measuring GSM

The GSM900 configuration is available by pressing  and using the  and  keys to select **GSM900**. Pressing **Confirm** completes the process.

The pre-installed setup configures the power meter for an average power measurement in a GSM RF burst. Triggering is achieved using the rising edge of the burst. The ‘useful’ part of the GSM burst lasts for 542.8 μ s with a rise time of 28 μ s. As the power meter triggers during the rising power transition, the measurement gate is configured to measure the average power in a 520 μ s period, 20 μ s after triggering.

The display (Figure 68) is configured to show the average power in the lower window in numeric format, while the upper window shows the power trace starting 40 μ s before the trigger. Table 13 shows the configuration.

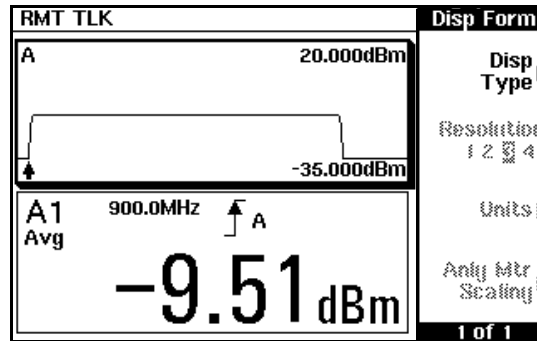

Figure 68 GSM Measurement Display

Table 13 GSM900 Configurations

Parameter	Setting
Channel	The E9321A and E9325A sensors are best suited as they have the optimum dynamic range and low-level stability in the 300 kHz bandwidth. (After a Preset, Video B/W defaults to High for all sensors.)
Sensor Mode:	Normal
Range:	AUTO
Filter:	AUTO
Offset:	Off
Frequency:	900 MHz
FDO Table:	Off
Video Avg:	Off
Video B/W:	E9321A, E9325A - High E9322A, E9326A - Med E9323A, E9327A - Low
Step Detect:	On
Gates	Only one gate is set up, starting 20 μ s after the trigger for a duration of 520 μ s.
Gate1 Start:	20 μ s
Length:	520 μ s
Gate2 Start:	0
Length:	0
Gate3 Start:	0
Length:	0
Gate4 Start:	0
Length:	0
Trigger	The trigger is configured for -20 dBm on a rising edge. A trigger hold off is also setup for 4275 μ s, disabling the trigger for 7.5 time slots, ensuring the same time slot is measured in the next frame.

Parameter	Setting
Acqn:	Cont Trig
Source:	Int (internal)
Level:	-20 dBm
Mode:	Normal
Slope:	+ (rising)
Delay:	20 μ s
Holdoff:	4275 μ s
Hysteresis:	0.0 dB
Output:	Off



The display is setup for a single numeric window and a trace window.

Upper window:	Trace
Lower Window:	Single Numeric



The trace window is configured to show the RF burst from 40 μ s ahead of the trigger for a duration of 700 μ s. The single numeric window is configured to display the average power in gate 1.

Upper Window: (Trace)

Max:	+ 20 dBm
Min:	-35 dBm
Start:	-40 μ s
Length:	700 μ s

Lower Window:

Gate 1:	average measurement
---------	---------------------

TIP If you require faster measurement speed, set the **Filter:** to **MAN** (Channel Setup screen) and reduce the filter value. Conversely, if you are measuring low power levels and want to improve the stability of the measurements, increase the filter value. Increasing the filter value however, reduces the measurement speed.

The maximum power level for the E-series E9320 power sensors is +20 dBm. Attenuation may be required when directly measuring GSM transmitter output. Enter the value of the attenuation as an **Offset**:



(, **Meas Select**) to correct the displayed measurement result.

Measuring EDGE

The EDGE configuration is available by pressing  and using the  and  keys to select **EDGE**. Pressing **Confirm** completes the process.

Enhanced Data for Global Evolution or Enhanced Data for GSM Evolution is an enhancement of the GSM standard. The modulation scheme is 8PSK. As Edge does not have constant amplitude GMSK modulation like GSM, peak-to-average ratio may be of interest.

The pre-installed setup configures the power meter for average and peak-to-average power measurements in a GSM RF burst. Triggering is achieved using the rising edge of the burst. The ‘useful’ part of the GSM burst lasts for 542.8 μ s with a rise time of 28 μ s. As the power meter triggers during the rising power transition, the measurement gate is configured to measure the average power in a 520 μ s period, 20 μ s after triggering.

The display (Figure 69) is configured to show the peak and peak-to-average results in the lower window in numeric format while the upper window shows the power trace starting 40 μ s before the trigger.

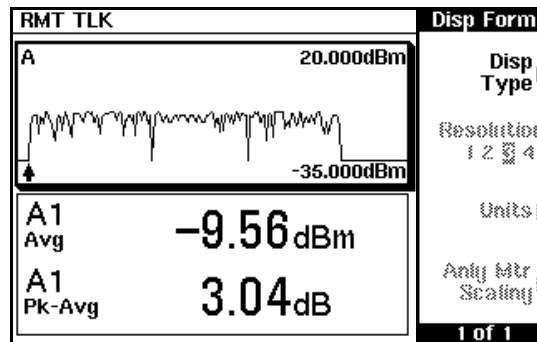





Figure 69 EDGE Measurement Display

Table 14 EDGE Configurations

Parameter	Setting
Channel	The E9321A and E9325A sensors are best suited as they have the optimum dynamic range and low-level stability in the 300 kHz bandwidth. (After a Preset, Video B/W defaults to High for all sensors.)
Sensor Mode:	Normal
Range:	AUTO
Filter:	AUTO
Offset:	Off
Frequency:	900 MHz
FDO Table:	Off
Video Avg:	Off
Video B/W:	E9321A, E9325A - High E9322A, E9326A - Med E9323A, E9327A - Low
Step Detect:	On
Gates	Only one gate is set up, starting 20 μ s after the trigger for a duration of 520 μ s.
Gate1 Start:	20 μ s
Length:	520 μ s
Gate2 Start:	0
Length:	0
Gate3 Start:	0
Length:	0
Gate4 Start:	0
Length:	0

Parameter	Setting
 Trigger	The trigger is configured for -20 dBm on a rising edge. A trigger hold off is also setup for 4275 μ s, disabling the trigger for 7.5 time slots, ensuring the same time slot is measured in the next frame. Also, trigger hysteresis is included to prevent small power transitions during the burst causing re-triggering.
Acqn:	Cont Trig
Source:	Int (internal)
Level:	-20 dBm
Mode:	Normal
Slope:	+ (rising)
Delay:	0
Holdoff:	4275 μ s
Hysteresis:	0.0 dB
Output:	Off
 Meas Display	The display is setup for a dual numeric window and a trace window.
Upper window:	Trace
Lower Window:	Dual Numeric
 Meas Setup	The trace window is configured to show the RF burst from 40 μ s ahead of the trigger for a duration of 700 μ s. The single numeric window is configured to display the average power in gate 1.
Upper Window:	
Max:	+ 20 dBm
Min:	-35 dBm
Start:	-40 μ s
Length:	700 μ s
Lower Window:	
Upper Line:	Gate 1: average measurement
Lower Line:	Gate 1: peak-to-average measurement



TIP If you require faster measurement speed, set the **Filter:** to **MAN** (Channel Setup screen) and reduce the filter value. Conversely, if you are measuring low power levels and want to improve the stability of the measurements, increase the filter value. Increasing the filter value however, reduces the measurement speed.

The maximum power level for the E-series E9320 power sensors is +20 dBm. Attenuation may be required when directly measuring transmitter output. Enter the value of the attenuation as an **Offset:**



(**Meas Select**) to correct the displayed measurement result.

Measuring NADC

The NADC configuration is available by pressing  and using the , and  keys to select **NADC**. Pressing **Confirm** completes the process.

The pre-installed setup configures the power meter for average power measurements of both active time slots in NADC or IS-136 'full rate' transmission. This assumes that there are two time slots in each frame to be measured, for example, time slots 0 in Figure 70.

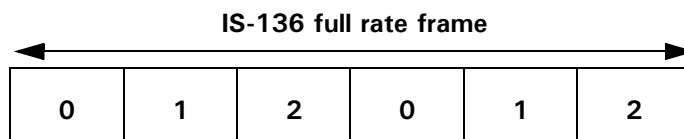

Figure 70 Full Rate Frame

Triggering is achieved using the rising edge of the burst. The measurement gates are configured to measure the average power in two NADC time slots, separated by two inactive time slots. The rise time of an NADC TDMA burst is approximately 123.5 μs (6bits) and the 'useful' part of the burst lasts approximately 6.4 ms. Gate 1 is configured to measure the average power in a 6.4ms period, 123.5 μs after triggering. Gate 2 is configured to measure the average power in a 6.4ms period, 20.123 ms (3 time slots plus rise times) after triggering.

The display (Figure 71) is configured to show the Gate 1 and Gate 2 average results in the lower window in numeric format, while the upper window shows the power trace starting 0.2 ms before the trigger.

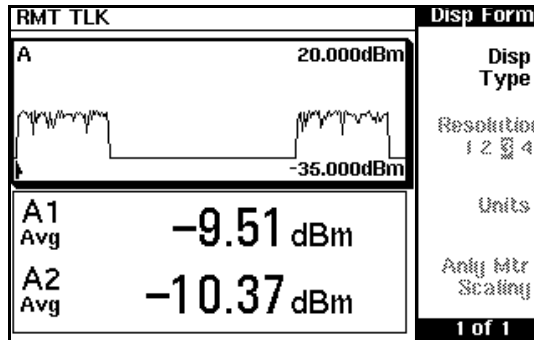





Figure 71 NADC Measurement Display

Table 15 NADC Configurations

Parameter	Setting
Channel	The narrow bandwidth of the NADC signal requires only the 30 kHz bandwidth of the E9321A and E9325A sensors in the Low setting and these are best suited. Other E9320 sensors may be used in their lowest setting but they provide less dynamic range and low-level stability. (After a Preset, Video B/W defaults to High for all sensors.)
Sensor Mode:	Normal
Range:	AUTO
Filter:	AUTO
Offset:	Off
Frequency:	800 MHz
FDO Table:	Off
Video Avg:	Off
Video B/W:	E9321A, E9325A - Low E9322A, E9326A - Low E9323A, E9327A - Low
Step Detect:	On
Gates	Two gates are configured as follows.
Gate1 Start:	123.5 μ s
Length:	6.46 μ s
Gate2 Start:	20.123 ms
Length:	6.46 ms
Gate3 Start:	0
Length:	0
Gate4 Start:	0
Length:	0



Parameter	Setting
 Trigger	The trigger is configured for a power level of -20 dBm on a rising edge. A trigger hold off is also setup for 30 ms, disabling the trigger for 4.5 time slots, ensuring the same time slot is measured each time.
	Acqn: Cont Trig
	Source: Int (internal)
	Level: -20 dBm
	Mode: Normal
	Slope: + (rising)
	Delay: 0
	Holdoff: 30 ms
	Hysteresis: 0.0 dB
	Output: Off
 Meas Display	The display is setup for a dual numeric window and a trace window.
	Upper window: Trace
	Lower Window: Dual Numeric
 Meas Setup	The dual numeric window is configured to display the average power in gate 1 and the average power in gate 2. The trace window is configured to show the RF burst from 0.2 ms ahead of the trigger for a duration of 28 ms.
	Upper Window:
	Max: + 20 dBm
	Min: -35 dBm
	Start: -0.2 ms
	Length: 28 ms
	Lower Window:
	Upper Line: Gate 1: average measurement
	Lower Line: Gate 2: average measurement

If you require faster measurement speed, set the **Filter:** to **MAN** (Channel Setup screen) and reduce the filter value. Conversely, if you are measuring low power levels and want to improve the stability of the measurements, increase the filter value. Increasing the filter value however, reduces the measurement speed.

The maximum power level for the E-series E9320 power sensors is +20 dBm. Attenuation may be required when directly measuring transmitter output. Enter the value of the attenuation as an **Offset:**

( , **Meas Select**) to correct the displayed measurement result.

Measuring iDEN

The iDEN configuration is available by pressing  and using the  and  keys to select **iDEN**. Pressing **Confirm** completes the process.

The pre-installed setup configures the power meter for average power and the peak-to-average power ratio measurements in one iDEN training and data pulse, and the average power in a 90 ms iDEN frame. Triggering is achieved using the rising edge of the training burst. Time gating is used to measure the average power in the following 15 ms pulse. The display is configured to show the peak-to-average ratio within the data pulse and the average power in the entire 90 ms frame on two display lines in the lower window while the upper window shows the average power in a 15 ms data pulse. All displays are numeric.

Table 16 iDEN Configurations

Parameter	Setting
Channel	The narrow bandwidth of the iDEN signal requires only the 30 kHz bandwidth of the E9321A and E9325A sensors in the Low setting and these are best suited. Other E9320 sensors may be used in their lowest setting but they provide less dynamic range and low-level stability.
Sensor Mode:	Normal
Range:	AUTO
Filter:	AUTO
Offset:	Off
Frequency:	800 MHz
FDO Table:	Off
Video Avg:	Off
Video B/W:	E9321A, E9325A - Low E9322A, E9326A - Low E9323A, E9327A - Low
Step Detect:	On
Gates	Two gates are configured as follows.
Gate1 Start:	10 μ s
Length:	15 ms
Gate2 Start:	0 s
Length:	90 ms
Gate3 Start:	0
Length:	0
Gate4 Start:	0
Length:	0
Trigger	The trigger is now configured for a power level of -20 dBm on a rising edge. Auto-level triggering is also be used. A trigger hold off is also setup to ensure the power meter is not re triggered by the data pulse following the training pulse.

Parameter	Setting
Acqn:	Cont Trig
Source:	Int (internal)
Level:	-20 dBm
Mode:	Normal
Slope:	+ (rising)
Delay:	0
Holdoff:	20 ms
Hysteresis:	0.0 dB
Output:	Off



The display is setup for a dual numeric window and a single numeric window.

Upper window:	Single Numeric
Lower Window:	Dual Numeric



The dual numeric window is configured to display the peak-to-average ratio in gate 1, and the average power in gate 2. The single numeric window is configured to display the average power in gate 1.

Upper Window:		
	Gate 1:	average measurement
Lower Window:		
Upper Line:	Gate 1:	peak-to-average measurement
Lower Line:	Gate 2:	average measurement



If you require faster measurement speed, set the **Filter:** to **MAN** (Channel Setup screen) and reduce the filter value. Conversely, if you are measuring low power levels and want to improve the stability of the measurements, increase the filter value. Increasing the filter value however, reduces the measurement speed.

The maximum power level for the E-series E9320 power sensors is +20 dBm. Attenuation may be required when directly measuring transmitter output. Enter the value of the attenuation as an **Offset:**



(**Meas Select**) to correct the displayed measurement result.

Measuring Bluetooth

The Bluetooth configuration is available by pressing  and using the , and  keys to select **Bluetooth**. Pressing **Confirm** completes the process.

The pre-installed setup configures the power meter for peak and average power measurements in a single Bluetooth DH1 data burst. Triggering is achieved using the rising edge of the burst. The measurement gate is configured to measure the peak and average power in a 366 μ s period, 0.2 μ s after the trigger.

The display (Figure 72) is configured to show the peak and average power in the lower window in numeric format, while the upper window shows the power trace over 6 time slots starting 50 μ s before the trigger.

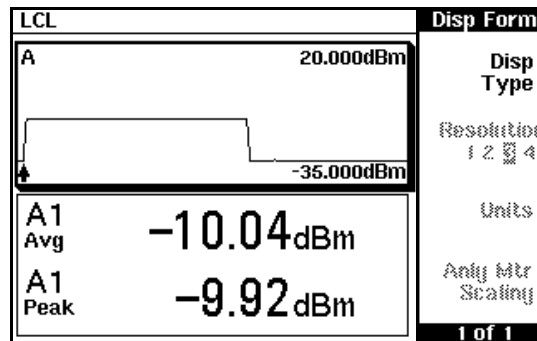

Figure 72 Bluetooth Measurement Display

Table 17 Bluetooth Configurations

Parameter	Setting
Channel	The E9321A and E9325A are not recommended due to lack of bandwidth. (After a Preset, Video B/W defaults to High for all sensors.)
Sensor Mode:	Normal
Range:	AUTO
Filter:	AUTO
Offset:	Off
Frequency:	2400 MHz
FDO Table:	Off
Video Avg:	Off
Video B/W:	E9322A, E9326A - Low E9323A, E9327A - Low
Step Detect:	On
Gates	Only one gate is set up.
Gate1 Start:	0.2 μ s
Length:	366 μ s
Gate2 Start:	0
Length:	0
Gate3 Start:	0
Length:	0
Gate4 Start:	0
Length:	0
Trigger	The trigger is now configured for a power level of -20 dBm on a rising edge. A trigger hold off is also setup for 650 μ s, disabling the trigger until the current time slot is measured.

Parameter	Setting
Acqn:	Cont Trig
Source:	Int (internal)
Level:	-20 dBm
Mode:	Normal
Slope:	+ (rising)
Delay:	0
Holdoff:	650 μ s
Hysteresis:	0.0 dB
Output:	Off



The display is setup for a dual numeric window and a trace window.

Upper window:	Trace
Lower Window:	Dual Numeric



The dual numeric window is configured to display the average power in gate 1 and the peak power in gate 1. The trace window is configured to show the RF burst from 50 μ s ahead of the trigger for a duration of 3.8 ms.

Upper Window:		
Max:		+ 20 dBm
Min:		-35 dBm
Start:		-50 μ s
Length:		3.8 ms
Lower Window:		
Upper Line:	Gate 1:	average measurement
Lower Line:	Gate 1:	peak measurement

TIP If you require faster measurement speed, set the **Filter:** to **MAN** (Channel Setup screen) and reduce the filter value. Conversely, if you are measuring low power levels and want to improve the stability of the measurements, increase the filter value. Increasing the filter value however, reduces the measurement speed.

The maximum power level for the E-series E9320 power sensors is +20 dBm. Attenuation may be required when directly measuring transmitter output. Enter the value of the attenuation as an **Offset**:

(, **Meas Select**) to correct the displayed measurement result.

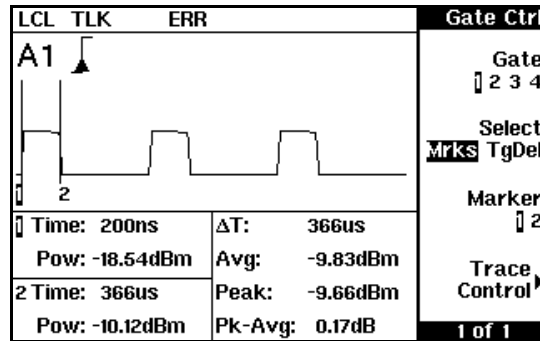





Figure 73 Markers on a Bluetooth Measurement

Measuring cdmaOne

The cdmaOne configuration is available by pressing  and using the , and  keys to select **cdmaOne**. Pressing **Confirm** completes the process.

The pre-installed setup configures the power meter for a continuous measurement on a cdmaOne signal. Peak and peak-to-average power measurements are made over a defined and statistically valid number of samples. With gated 10 ms measurements, corresponding to 200,000 samples, there is less than a 0.01% probability that there are no peaks above the measured peak value.

The display (Figure 74) is configured to show the peak, the average and the peak-to-average ratio.

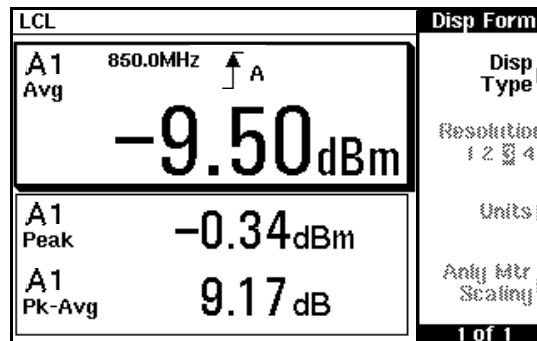

Figure 74 cdmaOne Measurement Display

Table 18 cdmaOne Configurations

Parameter	Setting
Channel	The E9322A and E9326A sensors are best suited due to their 1.5 MHz bandwidth. The E9321A and E9325A are not recommended due to their lack of bandwidth. (After a Preset, Video B/W defaults to High for all sensors.)
Sensor Mode:	Normal
Range:	AUTO
Filter:	AUTO
Offset:	Off
Frequency:	850 MHz
FDO Table:	Off
Video Avg:	Off
Video B/W:	E9322A, E9326A - High E9323A, E9327A - Medium
Step Detect:	On
Gates	Only one gate is set up, starting 1 μ s after the trigger for a duration of 10 ms.
Gate1 Start:	0 s
Length:	10 ms
Gate2 Start:	0
Length:	0
Gate3 Start:	0
Length:	0
Gate4 Start:	0
Length:	0
Trigger	The trigger is configured for continuous triggering on a rising edge at -10 dBm. This results in continuously updated results based on a 10 ms period relating to a position beyond 0.01% on the CCDF curve.

Parameter	Setting
Acqn:	Cont Trig
Source:	Int (internal)
Level:	-10 dBm
Mode:	Auto Level
Slope:	+ (rising)
Delay:	0
Holdoff:	0
Hysteresis:	0.0 dB
Output:	Off



The display is setup for a single numeric and a dual numeric window.

Upper window:	Single Numeric
Lower Window:	Dual Numeric



The single numeric window is configured to display the average power. The dual numeric window is configured to show the peak power and the peak-to-average ratio.

Upper Window:

Gate 1:	average measurement
---------	---------------------

Lower Window:

Upper Line:	Gate 1:	peak measurement
Lower Line:	Gate 1:	peak-to-average measurement



TIP If you require faster measurement speed, set the **Filter:** to **MAN** (Channel Setup screen) and reduce the filter value. Conversely, if you are measuring low power levels and want to improve the stability of the measurements, increase the filter value. Increasing the filter value however, reduces the measurement speed.

The maximum power level for the E-series E9320 power sensors is +20 dBm. Attenuation may be required when directly measuring transmitter output. Enter the value of the attenuation as an **Offset:**



(**Meas Select**) to correct the displayed measurement result.

Measuring W-CDMA

The W-CDMA configuration is available by pressing  and using the , and  keys to select **W-CDMA**. Pressing **Confirm** completes the process.

The pre-installed setup configures the power meter for a continuous power measurement on a W-CDMA signal. Peak and peak-to-average power measurements are made over a defined and statistically valid number of samples. With gated 10 ms measurements, corresponding to 200,000 samples, there is less than a 0.01% probability that there are no peaks above the measured peak value.

The display (Figure 75) is configured to show the peak, the average and the peak-to-average ratio.

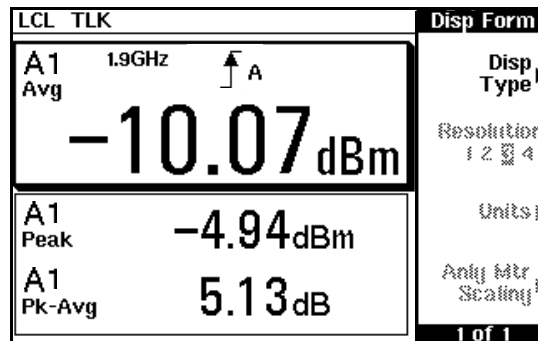

Figure 75 W-CDMA Measurement Display

Table 19 W-CDMA Configurations

Parameter	Setting
Channel	With 5 MHz bandwidth, the E9323A and E9327A sensors are best suited. The E9321A, E9322A, E9325A, and E9326A sensors are not recommended due to their lack of bandwidth (5 MHz required). (After a Preset, Video B/W defaults to High for all sensors.)
Sensor Mode:	Normal
Range:	AUTO
Filter:	AUTO
Offset:	Off
Frequency:	1900 MHz
FDO Table:	Off
Video Avg:	Off
Video B/W:	E9323A, E9327A - High
Step Detect:	On
Gates	Only one gate is set up, starting 1 μ s after the trigger for a duration of 10 ms.
Gate1 Start:	0 s
Length:	10 ms
Gate2 Start:	0
Length:	0
Gate3 Start:	0
Length:	0
Gate4 Start:	0
Length:	0
Trigger	The trigger is configured for continuous triggering on a rising edge at -10 dBm. This results in continuously updated results based on a 10 ms period relating to a position beyond 0.01% on the CCDF curve.

Parameter	Setting
Acqn:	Cont Trig
Source:	Int (internal)
Level:	-10 dBm
Mode:	Auto Level
Slope:	+ (rising)
Delay:	0
Holdoff:	0
Hysteresis:	0.0 dB
Output:	Off



The display is setup for a single numeric and a dual numeric window.

Upper window:	Single Numeric
Lower Window:	Dual Numeric



The single numeric window is configured to display the average power. The dual numeric window is configured to show the peak power and the peak-to-average ratio.

Upper Window:		
Gate 1:		average measurement
Lower Window:		
Upper Line:	Gate 1:	peak measurement
Lower Line:	Gate 1:	peak-to-average measurement



TIP If you require faster measurement speed, set the **Filter:** to **MAN** (Channel Setup screen) and reduce the filter value. Conversely, if you are measuring low power levels and want to improve the stability of the measurements, increase the filter value. Increasing the filter value however, reduces the measurement speed.

The maximum power level for the E-series E9320 power sensors is +20 dBm. Attenuation may be required when directly measuring transmitter output. Enter the value of the attenuation as an **Offset:**



(**Meas Select**) to correct the displayed measurement result.

Measuring cdma2000

The cdma2000 configuration is available by pressing  and using the , and  keys to select **cdma2000**. Pressing **Confirm** completes the process.

The pre-installed setup configures the power meter for a continuous power measurement on a cdma2000 signal. Peak and peak-to-average power measurements are made over a defined and statistically valid number of samples. With gated 10 ms measurements, corresponding to 200,000 samples, there is less than a 0.01% probability that there are no peaks above the measured peak value.

The display (Figure 75) is configured to show the peak, the average and the peak-to-average ratio.

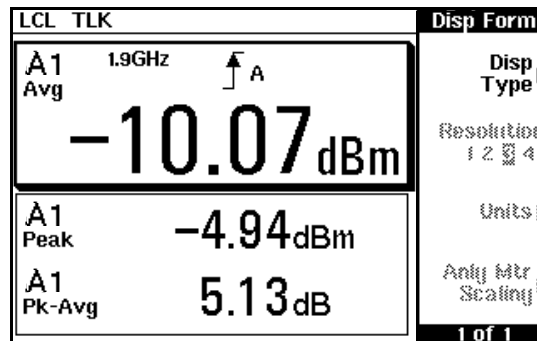

Figure 76 typical cdma2000 Measurement Display

Table 20 cdma2000 Configurations

Parameter	Setting
Channel	With 5 MHz bandwidth, the E9323A and E9327A sensors are best suited. The E9321A, E9322A, E9325A, and E9326A sensors are not recommended due to their lack of bandwidth (5 MHz required). (After a Preset, Video B/W defaults to High for all sensors.)
Sensor Mode:	Normal
Range:	AUTO
Filter:	AUTO
Offset:	Off
Frequency:	1900 MHz
FDO Table:	Off
Video Avg:	Off
Video B/W:	E9323A, E9327A - High
Step Detect:	On
Gates	Only one gate is set up, starting 1 μ s after the trigger for a duration of 10 ms.
Gate1 Start:	0 s
Length:	10 ms
Gate2 Start:	0
Length:	0
Gate3 Start:	0
Length:	0
Gate4 Start:	0
Length:	0
Trigger	The trigger is configured for continuous triggering on a rising edge at -10 dBm. This results in continuously updated results based on a 10 ms period relating to a position beyond 0.01% on the CCDF curve.

Parameter	Setting
Acqn:	Cont Trig
Source:	Int (internal)
Level:	-10 dBm
Mode:	Auto Level
Slope:	+ (rising)
Delay:	0
Holdoff:	0
Hysteresis:	0.0 dB
Output:	Off



The display is setup for a single numeric and a dual numeric window.

Upper window:	Single Numeric
Lower Window:	Dual Numeric



The single numeric window is configured to display the average power. The dual numeric window is configured to show the peak power and the peak-to-average ratio.

Upper Window:

Gate 1:	average measurement
---------	---------------------

Lower Window:

Upper Line:	Gate 1:	peak measurement
Lower Line:	Gate 1:	peak-to-average measurement

TIP If you require faster measurement speed, set the **Filter:** to **MAN** (Channel Setup screen) and reduce the filter value. Conversely, if you are measuring low power levels and want to improve the stability of the measurements, increase the filter value. Increasing the filter value however, reduces the measurement speed.

The maximum power level for the E-series E9320 power sensors is +20 dBm. Attenuation may be required when directly measuring transmitter output. Enter the value of the attenuation as an **Offset:**



(**Meas Select**) to correct the displayed measurement result.



4 Using E-Series E9300 Power Sensors

What You'll Find In This Chapter

This Chapter shows you how to use E-series E9300 power sensors with your EPM-P series power meter.

It contains the following sections:

- Introduction on page 160
 - Power Meter Configuration on page 161
 - Measurement Accuracy on page 163
 - Measuring Spread Spectrum and Multitone Signals on page 165
 - Measuring TDMA Signals on page 168
 - Electromagnetic Compatibility (EMC) Measurements on page 170
 - Measurement Accuracy and Speed on page 171
-

Introduction

The E-series E9300 power sensors are true average, wide dynamic range RF microwave power sensors. They are based on a dual sensor diode pair/attenuator/diode pair. This technique ensures the diodes in the selected signal path are kept in their square law region, thus the output current (and voltage) is proportional to the input power. The diode pair/attenuator/diode pair assembly can yield the average of complex modulation formats across a wide dynamic range, irrespective of signal bandwidth. Further refinements are included to improve power handling allowing accurate measurement of high level signals with high crest factors without incurring damage to the sensor.

These sensors measure average RF power on a wide variety of modulated signals and are independent of the modulation bandwidth. They are ideally suited to the average power measurement of multi-tone and spread spectrum signals such as CDMA, W-CDMA and digital television formats.

Please refer to the documentation supplied with your E-series E9300 power sensor for specification and calibration information.

Power Meter Configuration

The EPM-P series power meters automatically recognize an E-series E9300 power sensor when it is connected. The sensor calibration data is automatically read by the power meter. The power meter also configures the auto-averaging settings shown in Figure 77 to suit the power sensor characteristics.

	E9300/1/4A	E9300/1H	E9300/1B	Maximum Sensor Power	Resolution Setting			
					1	2	3	4
Sensor Dynamic Range	Upper Range	10 dBm	20 dBm	40 dBm	1	1	1	4
		2 dBm	12 dBm	32 dBm	1	1	4	16
		-4 dBm	6 dBm	26 dBm	1	1	8	32
		-10 dBm	0 dBm	20 dBm	1	4	16	128
					1	16	64	128
	Lower Range	-20 dBm	-10 dBm	10 dBm	1	1	1	4
		-30 dBm	-20 dBm	0 dBm	1	1	2	16
		-40 dBm	-30 dBm	-10 dBm	1	2	16	64
					4	16	128	256
		-50 dBm	-40 dBm	-20 dBm	32	64	256	256
			Minimum Sensor Power					

Figure 77 E-series E9300 Auto-averaging Settings

NOTE These values are valid only for the power meter channel connected to the E-series E9300 power sensor and only while the sensor is connected. You can also configure the settings manually - refer to Achieving Stable Results with TDMA Signals on page 168 if required.

Default Channel Setup

When an E-series E9300 power sensor is connected the following **Channel Setup** is automatically configured. Carrying out a Preset returns the power meter to this configuration.

Any changes made to the **Channel Setup** are retained after a power cycle.

RMT TLK		Input Set
Channel Setup		Change
Sensor Mode:	AVG only	
Range:	AUTO	
Filter:	AUTO 256	Gates >
Duty Cycle:	Off 1000%	
Offset:	Off 0.000dB	Trace Setup >
Frequency:	50.000MHz	
CF Table:	Off	
FDO Table:	Off	
Video Avg:	On 4	Done
Video B/W:	Off	
Step Detect:	On	
		1 of 1

Figure 78 E-series E9300 sensor default Channel Setup

Measurement Accuracy

Power sensors have small errors in their response over frequency. The response of each sensor is measured during manufacture to determine correction factors. With E-series power sensors, correction factors are held in Electrically Erasable Programmable Read Only Memory (EEPROM) and are downloaded to the power meter automatically.

Using calibration factors enables improved measurement accuracy. This section describes making average power measurements using the E-series E9300 power sensors.

Making a measurement requires the following steps:

- 1 Zero and calibrate the power meter/sensor combination.
- 2 Set the frequency for the signal you want to measure.
- 3 Make the measurement.

Table 21 Power Sensor Connection Requirements

Sensor	Connection Requirements
E9300A E9300H E9301A E9301H E9304A	These power sensors connect directly to the POWER REF.
E9300B E9301B	These power sensors are configured with an attenuator. Prior to calibration this attenuator must be removed. Replace the attenuator before making measurements.

Procedure First zero and calibrate the power meter/sensor combination.

- 1 Ensure the power sensor is disconnected from any signal source.
- 2 Press  and the channel **Zero** softkey to zero the channel. The **Zeroing** message and wait symbol are displayed.

- 3 Connect the power sensor to the POWER REF output using the connection method specified in Power Sensor Connection Requirements on page 163.
- 4 Press the channel **Cal** softkey to start the calibration routine. The **Calibrating** message and wait symbol are displayed.

TIP You can reduce the steps required to carry out the zero and calibration procedure as follows:

- Connect the power sensor to the POWER REF output.
- Press  and **Zero + Cal**. (For dual channel meters, press **Zero + Cal**, **Zero + Cal A** or **Zero + Cal B** as required.)

Now set the frequency of the signal you want to measure. The power meter automatically selects the appropriate calibration factor.

- 5 Press  and the channel **Freq** softkey to display the **Frequency** pop up window.

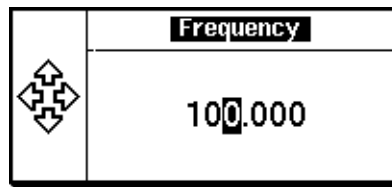





Figure 79 Frequency Pop Up Window

Use the , ,  and  keys to enter the frequency of the signal you want to measure.

- 6 Press **GHz** or **MHz** as required to complete the entry.

Now make the measurement.

- 7 Reconnect any required attenuators or adaptors and connect the power sensor to the signal to be measured.

The corrected measurement result is displayed.

Measuring Spread Spectrum and Multitone Signals

To achieve high data transfer rates within a given bandwidth, many transmission schemes are based around phase and amplitude (I and Q) modulation. These include CDMA, W-CDMA and digital television. The signals are characterized by their appearance on a spectrum analyzer display — a high amplitude noise-like signal of bandwidths up to 20 MHz. An 8 MHz bandwidth digital television signal is shown in Figure 80.

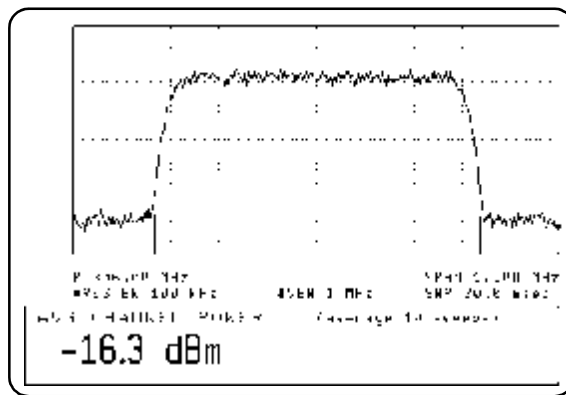

Figure 80 Spread Spectrum Signal

The diode pair/attenuator/diode pair architecture of the E-series E9300 power sensors is ideally suited to the average power measurement of these signals. The sensors have wide dynamic range (80 dB max, sensor dependent) and are bandwidth independent.

Some signal modulation formats such as orthogonal-frequency-division multiplexing (OFDM) and CDMA have large crest factors. The E-series E9300/1/4A power sensors can measure +20 dBm average power even in the presence of +13 dB peaks but the peak pulse duration must be less than 10 microseconds. For high power applications, such as base-station testing, the E9300/1B and E9300/1H are recommended.

CDMA Signal Measurements

Figure 81 and Figure 82 show typical results obtained when measuring a CDMA signal. In these examples, the error is determined by measuring the source at the amplitude of interest, with and without CDMA modulation, adding attenuation until the difference between the two values stops changing. The CW sensor in Figure 81 uses correction factors to correct for power levels beyond its square law operating region.

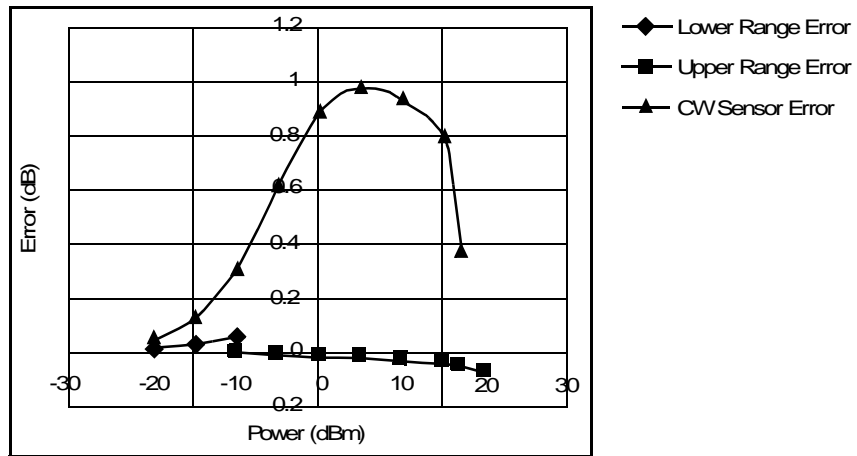

Figure 81 Wideband CDMA Error of E-series E9300 power sensor versus corrected CW sensor

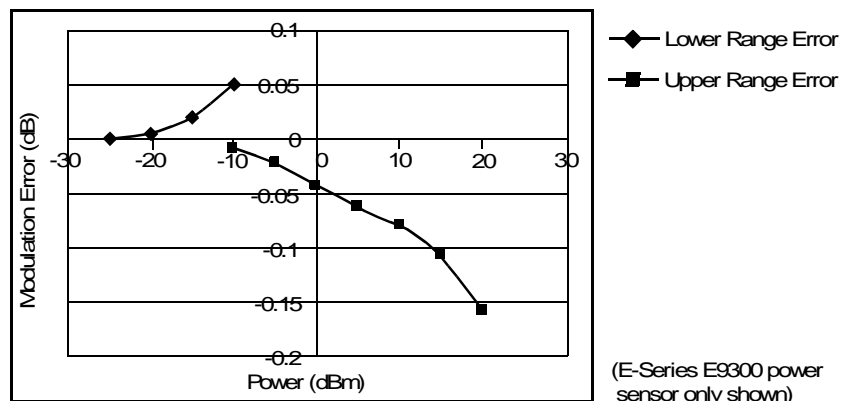

Figure 82 CDMA (IS-95A): 9Ch Fwd

Multitone Signal Measurements

In addition to wide dynamic range, the E-series E9300 power sensors also have an exceptionally flat calibration factor versus frequency response as shown in Figure 83. This is ideal for amplifier intermodulation distortion measurements where the components of the two-tone or multitone test signal can be separated by hundreds of MHz.

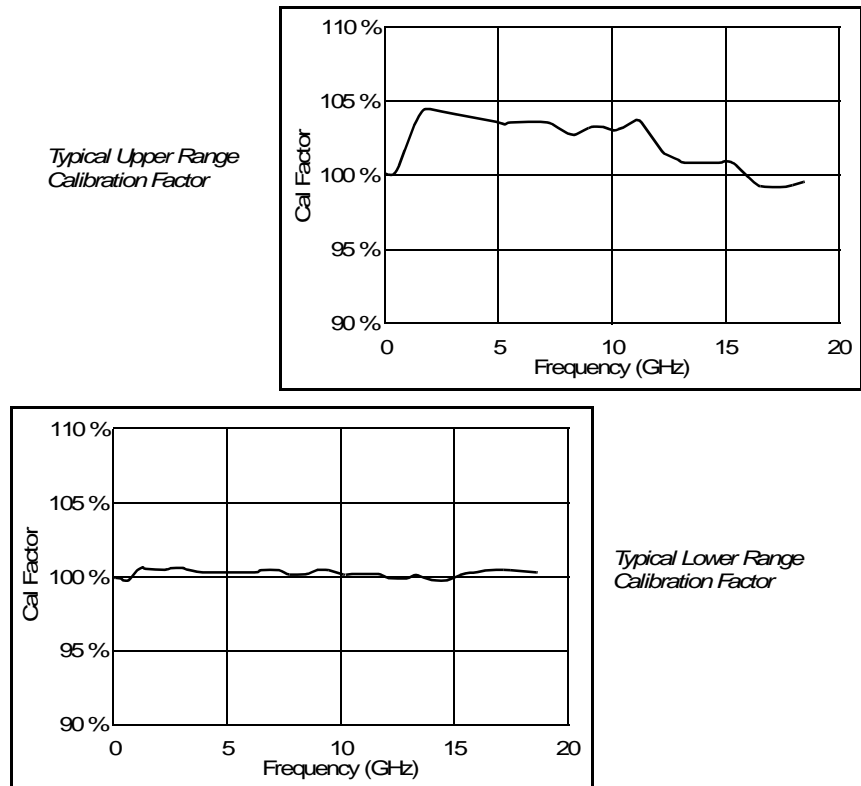
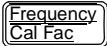

Figure 83 Calibration Factors versus Frequency

Simply select an suitable single calibration factor frequency for your measurement using the  key on the power meter.

Measuring TDMA Signals

Power Meter and Sensor Operation





The voltages generated by the diode detectors in the power sensor can be very small. Gain and signal conditioning are required to allow accurate measurement. This is achieved using a 440 Hz square wave output from the power meter to drive a chopper-amplifier in the power sensor. Digital Signal Processing (DSP) of the generated square wave is used by the power meter to recover the power sensor output and accurately calculate the power level.





The chopper-amplifier technique provides noise immunity and allows large physical distances between power sensor and power meter (Agilent 11730 series cables available up to 61 metres). Additional averaging helps reduce noise susceptibility.

Achieving Stable Results with TDMA Signals

The averaging settings in the power meter are designed to reduce noise when measuring continuous wave (CW) signals. Initial measurement of a pulsed signal may appear unstable with jitter on the less significant displayed digits. With pulsed signals the averaging period must be increased to allow measurement over many cycles of the pulsed signal.



Procedure Set the averaging as follows:

- 1 Press  to display the **Channel Setup** screen. In addition, on dual channel meters, you may need to press **Channel** to display the **Channel Setup** for the channel you want to use.
- 2 If **Filter: MAN** is not configured use  or  to highlight the **Filter:** setting.
- 3 Repeatedly press **Change** to scroll through the choices; **AUTO**, **MAN**, and **OFF**. Choose **MAN**.
- 4 With **MAN** selected, use  to select the filter length value and press **Change**.

- 5 Use , ,  and  to select and change the values as required. Confirm your entry by pressing **Enter**. (You can delete any changes and return to the Channel Setup simply by pressing **Cancel**.)
- 6 Press **Done** to complete the procedure.

NOTE You should also ensure the filter is not reset when a step increase or decrease in power is detected by switching the step detection off.

Procedure Switch off step detection as follows:

- 1 Press  to display the **Channel Setup**. In addition, on dual channel meters, you may need to press **Channel** to display the **Channel Setup** for the channel you want to use.
- 2 If **Step Detect:Off** is not configured use  or  to highlight the **Step Detect:** setting.
- 3 Press **Change** to select **Off**.
- 4 Press **Done** to complete the procedure.

Achieving Stable Results with GSM Signals

Signals with a pulse repetition frequency (PRF) close to a multiple or sub-multiple of the 440 Hz chopper-amplifier signal generate a beat note at a frequency between the PRF and 440 Hz. Control over the filter settings is again required to obtain stable results.

- TIP** The PRF of a GSM signal is approximately 217 Hz and thus requires more averaging than most other TDMA signals. To achieve a stable measurement use the filter setting procedures to set the **Length**. Experimentally, a **Length** setting of 148 gives optimum results although settings in the order of 31 or 32 give acceptable results if a faster measurement is required.

Electromagnetic Compatibility (EMC) Measurements

The low frequency range of the E9304A make it the ideal choice for making EMC measurements to CISPR (Comite International Special Perturbations Radioelectriques) requirements, and electromagnetic interference (EMI) test applications such as the radiated immunity test (IEC61000-4-3).

DC coupling of the E9304A input allows excellent low frequency coverage. However, the presence of any dc voltages mixed with the signal has an adverse effect on the accuracy of the power measurement.

CAUTION

The E9304A sensor is DC coupled. DC voltages in excess of the maximum value (5 Vdc) can damage the sensing diode.

Measurement Accuracy and Speed

The power meter has no internal ranges. The only ranges you can set are those of the E-series E9300 power sensors (and other E-series power sensors). With an E-series E9300 power sensor the range can be set either automatically or manually. Use autoranging when you are not sure of the power level you are about to measure.

CAUTION

To prevent damage to your sensor do not exceed the power levels specified in the Sensor *User's Guide*.

The E9304A sensor is DC coupled. DC voltages in excess of the maximum value (5 Vdc) can damage the sensing diode.

Setting the Range



There are two manual settings, **LOWER** and **UPPER**. The **LOWER** range uses the more sensitive path and the **UPPER** range uses the attenuated path in the E-series E9300 power sensors.

Sensor	LOWER range	UPPER range
E9300/1/4A	-60 dBm to -10 dBm	-10 dBm to +20 dBm
E9300/1B	-30 dBm to +20 dBm	+20 dBm to +44 dBm
E9300/1H	-50 dBm to 0 dBm	0 dBm to +30 dBm

The default is **AUTO**. In **AUTO** the range crossover value depends on the sensor model being used.

E9300/1/4A	E9300/1B	E9300/1H
-10 dBm \pm 0.5 dBm	+20 dBm \pm 0.5 dBm	0 dBm \pm 0.5 dBm

Procedure Set the range as follows:

- 1 Press  to display the **Channel Setup**. In addition, on dual channel meters, you may need to press **Channel** to display the **Channel Setup** for the channel you want to use.
- 2 Use  or  to highlight the **Range:** setting.
- 3 Press **Change** to scroll through the choices **AUTO**, **LOWER** or **UPPER** and choose as required.
- 4 Press **Done** to complete the procedure.

Measurement Considerations

While autoranging is a good starting point, it is not ideal for all measurements. Signal conditions such as crest factor or duty cycle may cause the power meter to select a range which is not the optimum configuration for your specific measurement needs. Signals with average power levels close to the range switch point require you to consider your needs for measurement accuracy and speed. For example, using an E9300/1/4A sensor, where the range switch point is -10 ± 0.5 dBm in a pulsed signal configured as follows:

Characteristic	Value
Peak Amplitude	-6 dBm
Duty Cycle	25 %

the calculated average power is -12 dBm.

Accuracy The value of -12 dBm lies in the lower range of the E-series E9300 power sensor. In autoranging mode (“AUTO”), the power meter determines the average power level is below -10 dBm and selects the low power path. However, the peak amplitude of -6 dBm is beyond the specified, square law response range of the low power path diodes. The high power path (-10 dBm to +20 dBm) should be used to ensure a more accurate measurement of this signal. However, range holding in “UPPER” (the high power path), for a more accurate measurement, results in considerably more filtering.

Speed and Averaging

The same signal also requires that consideration is given to measurement speed. As shown above, in autoranging mode the power meter selects the low power path in the E-series E9300 power sensor. With auto-averaging also configured, minimal filtering is applied. Values of 1 to 4 for average power levels above -20 dBm are used in the low power path. (Refer to E-series E9300 Auto-averaging Settings on page 161.)

If the range is held in “UPPER” for more accuracy, the measurement is slower. More filtering is applied due to the increase in noise susceptibility at the less sensitive area of the high power path. Values of 1 to 128 for average power levels less than -10 dBm are used. (Again, refer to E-series E9300 Auto-averaging Settings on page 161.) Manually lowering the filter settings speeds up the measurement but can result in an unwanted level of jitter.

Summary

Attention must be paid to signals whose average power levels are in the low power path range whilst their peaks are in the high power path range. You can achieve best accuracy by selecting the high power path or best speed by selecting the low power path.



5 Using E-Series 4410 Power Sensors

What You'll Find In This Chapter

This Chapter shows you how to use E-series 4410 power sensors with your EPM-P series power meter.

It contains the following sections:

- Introduction on page 176
 - Power Meter Configuration on page 177
 - Measurement Accuracy on page 179
-

Introduction

The E-series 4410 power sensors are diode based power sensors. They are intended for the measurement of CW microwave power levels in a wide dynamic range from -70 dBm to +20 dBm (100 pW to 100 mW). These are high-speed power sensors, and do not incorporate narrow-bandwidth averaging used in average-power sensors. Signals with digital, pulse, or other forms of amplitude modulation may introduce measurement errors.

Multi-tone signals (containing multiple frequency components), or signals with significant harmonic content (> -45 dBc) may introduce measurement errors at high power levels.

Please refer to the documentation supplied with your E-series 4410 power sensor for specification and calibration information.

Power Meter Configuration

The EPM-P series power meters automatically recognize an E-series 4410 power sensor when it is connected. The sensor calibration data is automatically read by the power meter. Also, the power meter automatically configures the averaging as shown in Figure 84.

	Maximum Sensor Power	Resolution Setting			
		1	2	3	4
Power Sensor Dynamic Range		1	1	1	8
	10 dB	1	1	1	16
	10 dB	1	1	2	32
	10 dB	1	1	16	256
	10 dB	1	8	128	128
	Minimum Sensor Power				
		Number of Averages			

Figure 84 E-series CW sensor Auto-averaging settings

NOTE These values are valid only for the power meter channel connected to the E-series 4410 power sensor and only while the sensor is connected. Averaging settings can also be manually configured.

Default Channel Setup

When an E-series 4410 power sensor is connected the following **Channel Setup** is automatically configured. Carrying out a Preset returns the channel to this configuration.

Any changes made to the **Channel Setup** are retained through a power cycle.

RMT TLK		Input Set
<u>Channel Setup</u>		
Sensor Mode:	AVG only	Change
Range:	AUTO	
Filter:	AUTO 128	Gates >
Duty Cycle:	Off 1000%	
Offset:	Off 0.00000	Trace
Frequency:	50.000MHz	Setup >
CF Table:	Off	
FDO Table:	Off	
Video Avg:	Off 4	Done
Video B/W:	Off	
Step Detect:	On	
		1 of 1

Figure 85 E-series CW sensor default Channel Setup

Measurement Accuracy

Power sensors have small errors in their response over frequency. The response of each sensor is measured during manufacture (and during periodic calibration). With E-series power sensors, the resulting frequency compensation information is written into Electrically Erasable Programmable Read Only Memory (EEPROM). This allows the frequency and calibration data to be downloaded to the power meter automatically.

Using calibration factors enables you to achieve improved measurement accuracy. This section describes making continuous wave measurements using the E-series 4410 power sensors.

Making a measurement requires the following steps:

- 1 Zero and calibrate the power meter/sensor combination.
- 2 Set the frequency for the signal you want to measure.
- 3 Make the measurement.

Procedure First zero and calibrate the power meter/sensor combination.

- 1 Ensure the power sensor is disconnected from any signal source.
- 2 Press  and the channel **Zero** softkey to zero the channel. The **Zeroing** message and wait symbol are displayed.
- 3 Connect the power sensor to the POWER REF output.
- 4 Press the channel **Cal** softkey to start the calibration routine. The **Calibrating** message and wait symbol are displayed.

TIP You can reduce the steps required to carry out the zero and calibration procedure as follows:

- Connect the power sensor to the POWER REF output.
- Press  and **Zero + Cal**. (For dual channel meters, press **Zero + Cal**, **Zero + Cal A** or **Zero + Cal B** as required.)

Now set the frequency of the signal you want to measure. The power meter automatically selects the appropriate calibration factor.

- 5 Press  and the channel **Freq** softkey to display the **Frequency** pop up window.

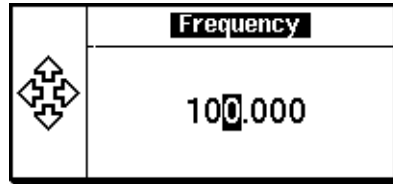





Figure 86 Frequency Pop Up Window

- 6 Use the , ,  and  keys to enter the frequency of the signal you want to measure.
- 7 Press **GHz** or **MHz** as required to complete the entry.

Now make the measurement.

- 8 Connect the power sensor to the signal to be measured.

The corrected measurement result is displayed.



6 Using 8480 Series Power Sensors

What You'll Find In This Chapter

This Chapter applies to all Agilent 8480 series power sensors. It shows you how to use the 8480 series power sensors with your EPM-P series power meter.

It contains the following sections:

- Introduction on page 182
 - Power Meter Configuration on page 183
 - Measurement Accuracy on page 185
 - Frequency Specific Calibration Factors on page 186
 - Sensor Calibration Tables on page 192
 - Editing/Generating Sensor Calibration Tables on page 196
 - Pre-installed Calibration Table Contents on page 200
-

Introduction

The 8480 series offers a wide range of both thermocouple and diode based power sensors. Many have very specific applications, for example the 110GHz W8486A or the +44 dBm 8482B. However, they do not have their calibration factors stored in EEPROM, unlike all E-series power sensors, and require that you use default calibration tables or manually enter the required correction factors. Likewise, they cannot be used to make peak or time gated measurements.

Please refer to the documentation supplied with your 8480 series power sensor for specification and calibration information.

Power Meter Configuration

The EPM-P series power meters automatically recognize an 8480 series power sensor when it is connected. The averaging settings shown in Figure 87 are automatically configured.

	Maximum Sensor Power	Resolution Setting			
		1	2	3	4
		1	1	1	8
10 dB		1	1	1	16
10 dB		1	1	2	32
10 dB		1	1	16	256
10 dB		1	8	128	128
	Minimum Sensor Power				

Power Sensor Dynamic Range (left vertical arrow) and Number of Averages (right vertical arrow) are indicated by the diagram.

Figure 87 8480 Series Auto-averaging Settings

NOTE These values are valid only for the power meter channel connected to the 8480 series power sensor and only while the sensor is connected. Averaging settings can also be manually configured.

Default Channel Setup

Figure 88 shows the **Channel Setup** configured automatically. Presetting returns the power meter to this configuration.

Any changes made to the **Channel Setup** are retained after a power cycle.

RMT TLK		Input Set
Channel Setup		Change
Sensor Mode:	AVG only	
Range:	AUTO	
Filter:	AUTO 128	< Gates >
Duty Cycle:	Off 1.000%	
Offset:	Off 0.000dB	Trace
Cal Fac:	100.0%	Setup >
CF Table:	Off	
FDO Table:	Off	
Video Avg:	On 4	Done
Video B/W:	Off	
Step Detect:	On	
		1 of 1

Figure 88 8480 series sensor default Channel Setup

Measurement Accuracy

Power sensors have small errors in their response over frequency. The response of each sensor is measured during manufacture (and during periodic calibration) and the resulting frequency compensation information is supplied in the form of calibration factors. Using calibration factors enables you to achieve improved measurement accuracy. The EPM-P series peak power meters provide two methods of using the calibration factors:

- inputting the individual calibration factor for a frequency prior to making the measurement, or
- using sensor calibration tables.

If you are making most of your measurements at a single frequency, or in a narrow range of frequencies, entering a specific calibration factor is the more effective method. Only a minimal amount of data entry is required.

However, if you are making measurements on a wide range of signal frequencies, a sensor table is more effective as you only need to enter the frequency of the signal you are measuring. The power meter automatically selects and applies the calibration factor from the selected table.

Frequency Specific Calibration Factors

This section shows you how to make a measurement using the calibration factor for the frequency of the signal you want to measure.

TIP This method is best suited to making several measurements at one frequency as you need only enter a small amount of data.

Using this method requires the following steps:

- 1 Zero and calibrate the power meter/sensor combination.
- 2 Set the calibration factor value for the frequency of the signal you want to measure.
- 3 Make the measurement.

Procedure First select and enter the reference calibration factor for the sensor you are using as follows:

- 1 Ensure the power sensor is disconnected from any signal source.
- 2 Refer to the connection requirements in Table 22 and ensure the sensor is ready for connection to the Power Reference.
- 3 Check the current reference calibration factor setting by pressing

 ,  . The value is displayed under the channel **Ref CF %** softkey.

Does this setting match the value for the sensor? (The power sensor reference calibration factor can normally be found above the calibration factors table on the power sensor body.)

- 4 If required, change this setting by pressing the channel **Ref CF**. The reference calibration factor pop up window is displayed as shown in Figure 89.

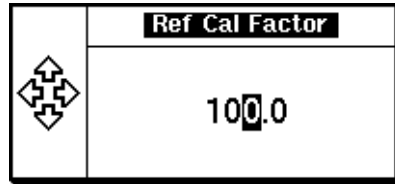

Figure 89 Reference Calibration Factor Pop Up Window

Modify this (see below) as required.

- Use or to highlight the digit you want to change.
 - Use or to increment or decrement the highlighted digit.
- 5 Confirm your choice by pressing **%**.

Now zero and calibrate the power meter/sensor combination as follows:

- 6 Press and the channel **Zero** softkey to zero the channel. The **Zeroing** message and wait symbol are displayed.
- 7 Connect the power sensor to the POWER REF output.
- 8 Press the channel **Cal** softkey to start the calibration routine. The **Calibrating** message and wait symbol are displayed.

Now set the sensor calibration factor for the frequency of the signal you want to measure.

- 9 Check the current calibration factor setting by pressing . The value is displayed under the channel **Cal Fac %** softkey.

Does this setting match the value for the sensor at the frequency of the signal you want to measure? (The calibration factors are presented in table form on the power sensor body. You may need to interpolate between values if the specific frequency is not listed)

10 If required, change this setting by pressing the channel **Cal Fac %**. The calibration factor pop up window is displayed as shown in Figure 90.

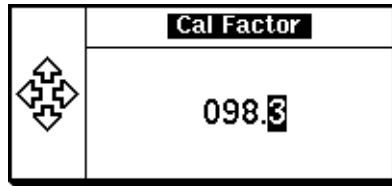





Figure 90 Calibration Factor Pop Up Window

Modify this (see below) as required.

- Use  or  to highlight the digit you want to change.
- Use  or  to increment or decrement the highlighted digit.

Confirm your choice by pressing **%**.

Now make the measurement as follows:

11 Connect the power sensor to the signal to be measured.

12 The corrected measurement result is displayed.

NOTE When no sensor tables are selected and **Single Numeric** display mode is chosen, the calibration factor used for the measurement is displayed in the upper window as shown in Figure 91.

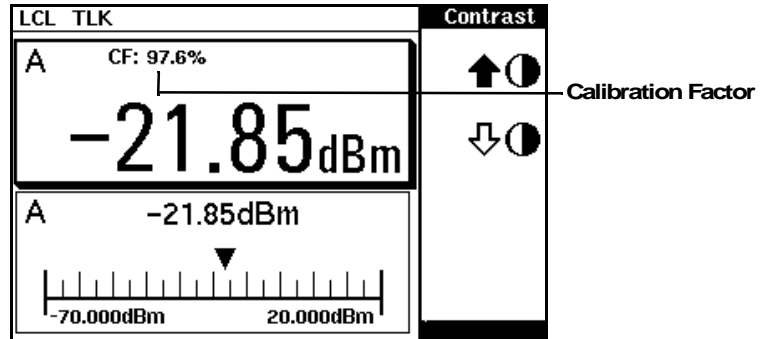

Figure 91 Calibration Factor Displayed













Table 22 8480 Series Connection Requirements

Sensor	Connection Requirements
8481A 8481H 8482A 8482H	These power sensors connect directly to the POWER REF.
8481D 8484A	Prior to calibration, an Agilent 11708A 30 dB reference attenuator should be connected between the power sensor and the POWER REF. Remove this attenuator from the power sensor input before making measurements.
8483A	This power sensor requires a 75 Ω (f) to 50 Ω (m) N-Type adapter (1250-0597) to connect to the POWER REF. Remove this adapter before making measurements.

Sensor	Connection Requirements
R8486A Q8486A V8486A W8486A R8486D Q8486D	These waveguide power sensors have two connectors. Use the N-Type connector to calibrate the power meter.
8481B 8482B	These power sensors are configured with an attenuator. Prior to calibration this attenuator must be removed. Replace the attenuator before making measurements.
8485A	This power sensor requires an APC 3.5 (f) to 50 Ω (m) N-Type adapter (08485-60005) to connect to the POWER REF. Remove this adapter before making measurements.
8485D	Prior to calibration, an Agilent 11708A 30 dB reference attenuator and an APC 3.5 (f) to 50 Ω (m) N-Type adapter (08485-60005) should be connected between the power sensor and the POWER REF. Remove this attenuator and adaptor before making measurements.
8487A	This sensor requires an APC 2.4 (f) to 50 Ω (m) N-Type adapter (08487-60001) to connect to the POWER REF. Remove this adapter before making measurements.
8487D	Prior to calibration, an Agilent 11708A 30 dB reference attenuator and an APC 2.4 (f) to 50 Ω (m) N-Type adapter (08487-60001) should be connected between the power sensor and the Power Ref. Remove this adapter before making measurements.

Example

To make a measurement on channel A with a power sensor which has a reference calibration factor of 99.8% and a calibration factor of 97.6% at the measurement frequency.

- Disconnect the power sensor from any signal source.
- Press , , **Ref CF %**.
- Use the , ,  and  keys to select and change the digits to display 99.8 in the pop up window.
- Complete the entry by pressing **%**.
- Press  and the channel **Zero** softkey to zero the channel.
- When the zeroing routine is complete connect the power sensor to the POWER REF output.
- Press the channel **Cal** softkey to start the calibration routine.
- When the calibration routine is complete press , **Cal Fac %**.
- Use the , ,  and  keys to select and change the digits to display 97.6 in the pop up window.
- Complete the entry by pressing **%**.
- Connect the power sensor to the signal to be measured.
- The corrected measurement result is displayed.

Sensor Calibration Tables

This section describes how to use sensor calibration tables. Sensor calibration tables store the measurement calibration factors, for a power sensor model or for a specific power sensor, in the power meter. They are used to correct measurement results.

TIP Use sensor calibration tables when you want to make power measurements over a range of frequencies using one or more power sensors.

The EPM-P series power meters are capable of storing 20 sensor calibration tables each containing up to 80 frequency points. The power meter is supplied with a set of 9 predefined sensor calibration tables plus a “100%” default table. The data in these tables is based on statistical averages for a range of Agilent Technologies power sensors. Your own sensor will most likely differ from the typical to some degree. If you require best accuracy, create a custom table for each sensor you use as shown in Editing/Generating Sensor Calibration Tables on page 196.

Using power sensor tables requires the following steps:

1. Choose the sensor table for the power sensor you are using and allocate it to the associated power meter channel.
2. Zero and calibrate the power meter. The reference calibration factor used during the calibration is automatically set by the power meter from the sensor calibration table.
3. Specify the frequency of the signal you want to measure. The calibration factor is automatically selected by the power meter from the sensor calibration table.
4. Make the measurement.

Procedure First select the table for the sensor you are using as follows:

- 1 Press **System**, **Tables**, **Sensor Cal Tables** to display the **Sensor Tbls** screen. The selected sensor table is indicated in the **State** column as shown in Figure 92. The sensors are listed 1 to 9 with a further 10 (10 to 19) available as custom tables. The **Pts** column shows the number of data points in the table.
- 2 Use the **↑** and **↓** keys to select the sensor model you are using.
- 3 Press **Table Off On** to highlight **On**. The **State** changes to **on** as shown in Figure 92.

LCL TLK		Sensor Tbls	
Tbl	Name	State	Pts
0	DEFAULT	off	2
1	HP8481A	on	19
2	HP8482A	off	12
3	HP8483A	off	10
4	HP8481D	off	21
5	HP8485A	off	22
6	R8486A	off	17
7	Q8486A	off	19
8	R8486D	off	17
9	HP8487A	off	54

Edit
Table

Table
Off **On**

Done

1 of 1

Figure 92 Sensor Table Selected

- 4 Press **Done** to complete the process.

Now enter the frequency of the signal you want to measure as follows:

- 5 Press  and the channel **Freq** softkey to display the **Frequency** pop up window.

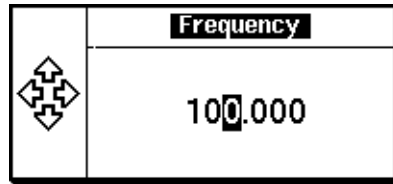







Figure 93 Frequency Pop Up Window

- 6 Use the , ,  and  keys to select and change the digits to match the frequency of the signal you want to measure.
- 7 Press **GHz** or **MHz** as required to complete the entry.

Now make the measurement.

- 8 Connect the power sensor to the signal to be measured.
- 9 The corrected measurement result is displayed.

NOTE If the measurement frequency does not correspond directly to a frequency in the sensor calibration table, the power meter calculates the calibration factor using linear interpolation. If you enter a frequency outside the frequency range defined in the sensor calibration table, the power meter uses the highest or lowest frequency point in the sensor calibration table to set the calibration factor.

NOTE When **Single Numeric** display mode is chosen, the frequency you entered and the sensor table identifier is displayed in the upper window. Also, pressing  displays the frequency you entered and calibration factor for each channel derived from the selected sensor tables.

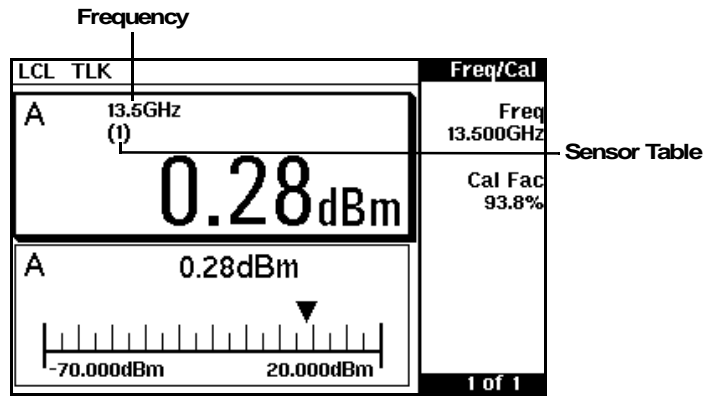

Figure 94 Frequency/Calibration Table Display

Editing/Generating Sensor Calibration Tables

To help achieve the best accuracy in your measurement you can enter the values supplied for the sensors you are using by editing the installed sensor calibration tables or by generating your own custom tables. While you cannot delete any of the 20 sensor calibration tables, you can edit or delete their contents. If you need another table you should edit and re-name one of the tables. A maximum of 80 frequency/calibration factor data points can be stored in each table.

You can view the installed sensor tables by pressing , **Tables**, **Sensor Cal Tables** to display the **Sensor Tbls** screen as shown in Figure 92.

These power sensors are:

Table 23 Installed Power Sensor Models

Table	Sensor Model	Table	Sensor Model
0	DEFAULT ¹	5	8485A
1	8481A	6	R8486A
2	8482A ²	7	Q8486A
3	8483A	8	R8486D
4	8481D	9	8487A

¹DEFAULT is a sensor calibration table where the reference calibration factor and calibration factors are 100%. This sensor calibration table can be used during the performance testing of the power meter.

²The Agilent 8482B and Agilent 8482H power sensors use the same data as the Agilent 8482A.

There are also ten sensor calibration tables named **CUSTOM_0** through **CUSTOM_9**. These tables do not contain any data when the power meter is shipped from the factory.

Editing or generating power sensor tables requires the following steps:

1. Identify and select the sensor table you want to edit or create.
2. Rename the table.
3. Edit/enter the frequency and calibration factor data pairs.
4. Save the table



Procedure First select the table you want to edit or create as follows:

- 1 Press , **Tables**, **Sensor Cal Tables** to display the **Sensor Tbls** screen.

RMT TLK				Sensor Tbls
Tbl	Name	State	Pts	
0	DEFAULT	off	2	Edit Table
1	HP8481A	off	19	Table
2	HP8482A	off	12	Off On
3	HP8483A	off	10	
4	HP8481D	off	21	
5	HP8485A	off	22	
6	R8486A	off	17	
7	Q8486A	off	19	Done
8	R8486D	off	17	
9	HP8487A	off	54	

1 of 1

Figure 95 "Sensor Tbls" Screen

- 2 Choose the table you want to edit using the  and  keys. Press **Edit Table** to display the **Edit Cal** screen as shown in Figure 96.

RMT TLK		Edit Cal
Name: HP8481A		Change
Ref CF: 100.0%		
Freq	Cal Fac	Insert
50.000MHz	100.0%	
100.000MHz	99.8%	
2.000GHz	99.0%	
3.000GHz	98.6%	Delete
4.000GHz	98.0%	
5.000GHz	97.7%	
6.000GHz	97.4%	Done
7.000GHz	97.1%	





1 of 1

Figure 96 "Edit Cal" Screen

NOTE A frequency in the range of 0.001 MHz to 999.999 GHz can be entered. A calibration factor in the range of 1% to 150% can be entered. The following rules apply to naming sensor calibration tables:

- The name must consist of no more than 12 characters.
- All characters must be upper or lower case alphabetic characters, or numeric (0-9), or an underscore (_).
- No other characters are allowed.
- No spaces are allowed in the name.







Now change the title of the table as follows:

3 Highlight the table title using the  and  keys. Press **Change** and use the , ,  and  keys to select and change the characters create the name you want to use.





- Pressing **Insert Char** adds a new character to the right of the selected character.
- Pressing **Delete Char** removes the selected character.

Press **Enter** to complete the entry.





Enter the reference calibration factor as follows:

4 Using the  and  keys, select the reference calibration factor value and press **Change**. Use the , ,  and  keys to change the value to match the power sensor. Press **%** to complete the entry.

Edit and/or enter the frequency and calibration factor pairs as follows:

5 Use the , ,  and  keys to select the frequency or calibration factors in the table

6 Press **Change** and edit the value to match the sensor you want to use. Complete the entry by pressing the **%**, **GHz** or **MHz** keys.

- 7 Enter additional frequency/calibration factor pairs by pressing **Insert** when the **Edit Cal** screen is displayed. You are prompted to enter the frequency first followed by the respective calibration factor. The power meter automatically sets up the table in frequency ascending order.
- 8 When you have finished editing the table press **Done**.
- 9 Use the , ,  and  keys and the channel **Table Off On** to allocate the new table to the measurement channel.
- 10 Press **Done** to complete the editing process and save the table.

NOTE Ensure that the frequency points you use cover the frequency range of the signals you want to measure. If you measure a signal with a frequency outside the frequency range defined in the sensor calibration table, the power meter uses the highest or lowest frequency point in the sensor calibration table to calculate the calibration factor.

Pre-installed Calibration Table Contents

The following lists detail the contents of the installed sensor calibration tables.

DEFAULT	
RCF	100
0.1 MHz	100
110 GHz	100

Agilent 8481A	
RCF	100
50 MHz	100
100 MHz	99.8
2 GHz	99
3 GHz	98.6
4 GHz	98
5 GHz	97.7
6 GHz	97.4
7 GHz	97.1
8 GHz	96.6
9 GHz	96.2
10 GHz	95.4
11 GHz	94.9
12.4 GHz	94.3
13 GHz	94.3
14 GHz	93.2
15 GHz	93
16 GHz	93
17 GHz	92.7
18 GHz	91.8

Agilent 8482A	
RCF	98
0.1 MHz	98
0.3 MHz	99.5
1 MHz	99.3
3 MHz	98.5
10 MHz	98.5
30 MHz	98.1
100 MHz	97.6
300 MHz	97.5
1 GHz	97
2 GHz	95
3 GHz	93
4.2 GHz	91

Agilent 8483A	
RCF	94.6
0.1 MHz	94
0.3 MHz	97.9
1 MHz	98.4
3 MHz	98.4
10 MHz	99.3
30 MHz	98.7
100 MHz	97.8
300 MHz	97.5
1 GHz	97.2
2 GHz	96.4

Agilent 8481D	
RCF	99
50 MHz	99
500 MHz	99.5
1 GHz	99.4
2 GHz	99.5
3 GHz	98.6
4 GHz	98.6
5 GHz	98.5
6 GHz	98.5
7 GHz	98.6
8 GHz	98.7
9 GHz	99.5
10 GHz	98.6
11 GHz	98.7
12 GHz	99
12.4 GHz	99.1
13 GHz	98.9
14 GHz	99.4
15 GHz	98.9
16 GHz	99.1
17 GHz	98.4
18 GHz	100.1

Agilent R8486A	
RCF	100
50 MHz	100
26.5 GHz	94.9
27 GHz	94.9
28 GHz	95.4
29 GHz	94.3
30 GHz	94.1
31 GHz	93.5
32 GHz	93.7
33 GHz	93.7
34 GHz	94.9
34.5 GHz	94.5
35 GHz	94.4
36 GHz	93.7
37 GHz	94.9
38 GHz	93.5
39 GHz	93.9
40 GHz	92.3

Agilent 8485A	
RCF	100
50 MHz	100
2 GHz	99.5
4 GHz	98.9
6 GHz	98.5
8 GHz	98.3
10 GHz	98.1
11 GHz	97.8
12 GHz	97.6
12.4 GHz	97.6
14 GHz	97.4
16 GHz	97
17 GHz	96.7
18 GHz	96.6
19 GHz	96
20 GHz	96.1
21 GHz	96.2
22 GHz	95.3
23 GHz	94.9
24 GHz	94.3
25 GHz	92.4
26 GHz	92.2
26.5 GHz	92.1

Agilent R8486D	
RCF	97.6
50 MHz	97.6
26.5 GHz	97.1
27 GHz	95.3
28 GHz	94.2
29 GHz	94.5
30 GHz	96.6
31 GHz	97.6
32 GHz	98
33 GHz	98.9
34 GHz	99.5
34.5 GHz	99
35 GHz	97.6
36 GHz	99
37 GHz	98.2
38 GHz	97.4
39 GHz	97.6
40 GHz	100

Agilent 8487A	
RCF	100
50 MHz	100
100 MHz	99.9
500 MHz	98.6
1 GHz	99.8
2 GHz	99.5
3 GHz	98.9
4 GHz	98.8
5 GHz	98.6
6 GHz	98.5
7 GHz	98.4
8 GHz	98.3
9 GHz	98.3
10 GHz	98.3
11 GHz	98.1
12 GHz	97.9
13 GHz	98
14 GHz	98.2
15 GHz	97.7
16 GHz	96.8
17 GHz	97
18 GHz	96.3
19 GHz	95.9
20 GHz	95.2
21 GHz	95.6
22 GHz	95.5
23 GHz	95.4
24 GHz	95
25 GHz	95.4
26 GHz	95.2
27 GHz	95.1
28 GHz	95
29 GHz	94.4
30 GHz	94
31 GHz	93.7
32 GHz	93.8
33 GHz	93
34 GHz	93.2
34.5 GHz	93.5

Agilent 8487A continued	
35 GHz	93.1
36 GHz	92
37 GHz	92.4
38 GHz	90.9
39 GHz	91.3
40 GHz	91.4
41 GHz	90.6
42 GHz	89.9
43 GHz	89.1
44 GHz	88.1
45 GHz	86.9
46 GHz	85.8
47 GHz	85.4
48 GHz	83.2
49 GHz	81.6
50 GHz	80.2

Agilent Q8486A	
RCF	100
50 MHz	100
33.5 GHz	91.3
34.5 GHz	92
35 GHz	91.7
36 GHz	91.5
37 GHz	92.1
38 GHz	91.7
39 GHz	91
40 GHz	90.7
41 GHz	90.3
42 GHz	89.5
43 GHz	88.5
44 GHz	88.7
45 GHz	88.2
46 GHz	87
47 GHz	86.4
48 GHz	85.3
49 GHz	84.7
50 GHz	82.9



7 Maintenance

What You'll Find in This Chapter

This chapter describes the built in tests, error messages, and general maintenance. It contains these sections:

- Self Test on page 204
 - Error Messages on page 211
 - Operator Maintenance on page 224
 - Contacting Agilent Technologies on page 226
-

Self Test

The power meter has two self test modes:

- Power on self test - occurs automatically when you turn on the power meter.
- Troubleshooting mode - accessed via the front panel or remotely. The front panel softkey menu allows you to run individual tests, whereas the remote command runs a complete series of tests as listed in Remote Testing on page 207.

Power On Self Test



The power on self test is performed automatically when the power meter is turned on and takes approximately 10 seconds to complete. The power on self test checks following components:

- Lithium Battery
- Calibrator
- Measurement Assembly (Both assemblies on dual channel meters.)
- Fan
- Serial Interface

Refer to see Test Descriptions on page 208 if you require a description of each individual test.

As the power on self test takes place, the message **Testing...** appears next to the name of the test which is being performed. When each test is complete, the message **Testing...** is replaced by either the message **Passed** or **Failed**. If a failure occurs the message **Power-up H/W Err** appears. Any errors are also written to the error queue and can be examined in the **Errors** screen by pressing , **Error List**.

Front Panel Selection of Self Tests

Press , , **Service**, **Self Test** to access the **Self Test** menu consisting of the following:

- Instrument Self Test
- Individual, accessing the following tests:
 - Keyboard
 - Fan
 - Display bitmaps
 - Serial Interface, accessing the following tests:
 - ◆ UART Configuration
 - ◆ Local Loop Back
 - ◆ RS232 Loop Back
 - ◆ RS422 Loop Back

 accesses:

- Trigger Loop back
- Time base
- Fast Path Accuracy

NOTE The RS232 and RS422 loop back tests require a specially wired connector - refer to the *EPM-P series power meter Service Guide*.

Each of these tests can be run individually. Information on the instrument self test and confidence check are described in Instrument Self Test on page 206. Refer to Test Descriptions on page 208 if you require a description of the other tests.

Instrument Self Test

If **Instrument Self Test** is selected, the following tests are run: (These are the same tests which are run using the *TST? command.)

- ROM checksum
- RAM
- Lithium Battery
- Display Assembly
- Calibrator
- Measurement Assemblies
- Fan
- Serial Interface

As each test takes place, the name of the test is listed on the screen. While a test is running, the message **Testing...** appears beside the name of the test. As each stage of the test is completed, the **Testing...** message is replaced by either **Passed** or **Failed**.

RMT TLK		Self Test▶
TEST	RESULT	
ROM	Passed	
RAM	Passed	
RAM Battery	Passed	
Display Assy.	Passed	
Calibrator	Passed	
Meas. Assy.	Passed	
Serial Interface	Testing...	
		Done

Figure 97 Self Test in Progress

When the test is complete, the result is displayed until **Done** is selected. If the self test failed, information about the failure is displayed on the screen.

Remote Testing

To invoke the remote self test, the IEEE 488.1 compliant standard command, *TST? is used. This command runs a full self test and returns one of the following codes:

- 0 - no tests failed
- 1 - one or more tests failed

The remote self test consists of the following tests:

- ROM checksum
- RAM
- Lithium Battery
- Display Assembly
- Calibrator
- Measurement Assemblies
- Communications Assembly (Implicit)

The communications assembly is tested implicitly, in that the command will not be accepted or return a result unless the GPIB interface is functioning correctly.

Refer to see Test Descriptions on page 208 if you require a description of each individual test.

When the *TST? command is executed, the screen is cleared. As each test takes place, the name of the test is listed on the screen. While a test is running, the message **Testing...** appears beside the name of the test. As each stage of the test is completed, the message **Testing...** is replaced by either the message **Passed** or **Failed**.

Test Descriptions

This section specifies what is actually checked by each of the tests. Some of the tests may only be applicable to one method of invocation (for example, from the front panel). If this is the case, it is specified in the test description. Most of the tests have an associated error message which is added to the error queue if the test fails. The exception to this is the bitmap display test. Refer to Error Messages on page 211 for more details.

ROM Checksum

This test calculates the checksum of the firmware and checks it against the pre-defined checksum stored on the ROM. A pass or a fail result is returned.

RAM

This test carries out a read and write test on the instrument RAM.

Lithium Battery

When the firmware is first downloaded, a known value is written into a battery-backed memory location. This test verifies that the value is still resident. It returns a pass if the value is still present, otherwise it returns a fail.

Measurement Assemblies

A measurement assembly is requested to automatically run a self test. This self test returns either a pass or a fail. A fail can either be produced by the measurement assembly self test failing or by the measurement assembly not responding.

Fan

This test confirms that the internal cooling fan is operating.

Serial Interface

Four tests are available for the serial interface: UART configuration, local loop back, RS232 loop back and RS422 loop back. Both the RS232 and RS422 loop back tests require a specially wired connector - refer to the *EPM-P series power meter Service Guide*.

- UART Configuration - confirms that the baud rate, stop bits and parity settings are correctly configured on the UART.
- Local Loop Back - Tx and Rx on the UART are internally connected and a test message is sent to confirm correct operation.
- RS232/RS422 Loop Back - A message is sent via the UART and transceivers using an external loop back connector (refer to the *EPM-P series power meter Service Guide*).

Calibrator

The reference calibrator is turned on (indicated by the POWER REF LED) and measured internally. A pass or fail result is returned.

Display

Three tests are available for the display: the display assembly, display RAM and bitmap display.

A read/write is performed on the display RAM. If the value which is written is read back correctly, a pass is recorded, otherwise a fail is recorded.

The liquid crystal display/ light emitting diode (LCD/LED) control circuits are tested by making separate voltage measurements via the multiplexer and digital signal processor. If the expected voltages are measured, a pass is recorded, otherwise a fail is recorded. The three circuits tested are the LCD contrast control, the LED brightness control, and the display temperature sensing diode.

Trigger Loop Back

This test generates a level on the trigger output and verifies that it can be seen on the trigger input. You are required to make the connection between the trigger input and output connectors (BNC).

Time Base

This test routes the 10 MHz internal time base signal to the trigger output connector where frequency verification can be made. When the power meter is preset or power cycled, the routing is removed.

Fast Path Accuracy

This test requires specialized test equipment and is beyond the scope of this guide. Please refer to the *EPM-P series power meters Service Guide*.

Error Messages

Introduction

This section contains information about error messages. It explains how to read the power meter's error queue and lists all error messages and their probable causes.

When there is a hardware related problem, for example, a power sensor overload, the error message is displayed on the status line at the top of the display. In addition, the errors are also written to the error queue. If there are any errors in the error queue the front panel error indicator is displayed as shown in Figure 98.

Other errors can also be generated when the power meter is being operated over the remote interface. These errors also display the error indicator and are written to the error queue.

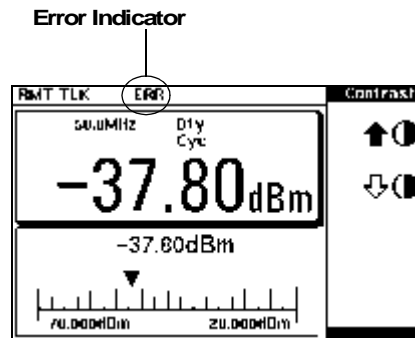

Figure 98 Error Indicator Position

To read the error queue from the front panel:

- Press **System**, **Error List** and use **Next** to scroll through each error message.

To read the error queue from the remote interface use:

- the `SYSTEM:ERROR?` command.

Error queue messages have the following format:



Figure 99 Error Queue Message

For example, -330, "Self-test Failed;Battery Fault".

Errors are retrieved in a first in first out (FIFO) order. If more than 30 errors occur, the error queue overflows and the last error in the queue is replaced with error -350, "Queue Overflow". Any time the queue overflows the most recent error is discarded.

When the errors are read they are removed from the error queue. This opens a position at the end of the queue for a new error message, if one is subsequently detected. When all errors have been read from the queue, further error queries return +0, "No errors".

To delete all the errors in the queue from the front panel press:

- **System**, **Error List** and use **Clear Errors**.

To delete all the errors in the queue remotely use:

- the *CLS (clear status) command.

The error queue is also cleared when the instrument power has been switched off.

Error Message List

-101	Invalid character An invalid character was found in the command string. You may have inserted a character such as #, \$, or % in the command header or within a parameter. For example, LIM:LOW O#.
-102	Syntax error Invalid syntax was found in the command string. For example, LIM:CLE:AUTO, 1 or LIM:CLE: AUTO 1.
-103	Invalid separator An invalid separator was found in the command string. You may have used a comma instead of a colon, semicolon, or blank space; or you may have used a blank space instead of a comma. For example, OUTP:ROSC,1.
-105	GET not allowed A Group Execute Trigger (GET) is not allowed within a command string.
-108	Parameter not allowed More parameters were received than expected for the command. You may have entered an extra parameter, or added a parameter to a command that does not accept a parameter. For example, CAL 10.
-109	Missing parameter Fewer parameters were received than expected for the command. You omitted one or more parameters that are required for this command. For example, AVER:COUN.
-112	Program mnemonic too long A command header was received which contained more than the maximum 12 characters allowed. For example, SENSEAVERAgeCOUNt 8.

-113	Undefined header A command was received that is not valid for this power meter. You may have misspelled the command, it may not be a valid command or you may have the wrong interface selected. If you are using the short form of the command, remember that it may contain up to four letters. For example, TRIG:SOUR IMM.
-121	Invalid character in number An invalid character was found in the number specified for a parameter value. For example, SENS:AVER:COUN 128#H.
-123	Exponent too large A numeric parameter was found whose exponent was larger than 32,000. For example, SENS:COUN 1E34000.
-124	Too many digits A numeric parameter was found whose mantissa contained more than 255 digits, excluding leading zeros.
-128	Numeric data not allowed A numeric value was received within a command which does not accept a numeric value. For example, MEM:CLE 24.
-131	Invalid suffix A suffix was incorrectly specified for a numeric parameter. You may have misspelled the suffix. For example, SENS:FREQ 200KZ.
-134	Suffix too long A suffix used contained more than 12 characters. For example, SENS:FREQ 2MHZZZZZZZZZZZZ.

-138	Suffix not allowed A suffix was received following a numeric parameter which does not accept a suffix. For example, INIT:CONT 0Hz.
-148	Character data not allowed A discrete parameter was received but a character string or a numeric parameter was expected. Check the list of parameters to verify that you have used a valid parameter type. For example, MEM:CLE CUSTOM_1.
-151	Invalid string data An invalid string was received. Check to see if you have enclosed the character string in single or double quotes. For example, MEM:CLE "CUSTOM_1.
-158	String data not allowed A character string was received but is not allowed for the command. Check the list of parameters to verify that you have used a valid parameter type. For example, LIM:STAT 'ON'.
-161	Invalid block data A block data element was expected but was invalid for some reason. For example, *DDT #15FET. The 5 in the string indicates that 5 characters should follow, whereas in this example there are only 3.
-168	Block data not allowed A legal block data element was encountered but not allowed by the power meter at this point. For example SYST:LANG #15FETC?.
-178	Expression data not allowed A legal expression data was encountered but not allowed by the power meter at this point. For example SYST:LANG (5+2).

-211	<p>Trigger ignored Indicates that <GET> or *TRG, or TRIG:IMM was received and recognized by the device but was ignored because the power meter was not in the wait for trigger state.</p>
-213	<p>Init ignored Indicates that a request for a measurement initiation was ignored as the power meter was already initiated. For example, INIT:CONT ON INIT.</p>
-214	<p>Trigger deadlock TRIG:SOUR was set to HOLD or BUS and a READ? or MEASure? was attempted, expecting TRIG:SOUR to be set to IMMEDIATE.</p>
-220	<p>Parameter error;Frequency list must be in ascending order. Indicates that the frequencies entered using the MEMory:TABLE:FREQuency command are not in ascending order.</p>
-221	<p>Settings conflict This message occurs under a variety of conflicting conditions. The following list gives a few examples of where this error may occur:</p> <ul style="list-style-type: none">•If the READ? parameters do not match the current settings.•If you are in fast mode and attempting to switch on for example, averaging, duty cycle or limits.•Trying to clear a sensor calibration table when none is selected.
-221	<p>Settings conflict;DTR/DSR not available on RS422 DTR/DSR is only available on the RS232 interface.</p>
-222	<p>Data out of range A numeric parameter value is outside the valid range for the command. For example, SENS:FREQ 2KHZ.</p>
-224	<p>Illegal parameter value A discrete parameter was received which was not a valid choice for the command. You may have used an invalid parameter choice. For example, TRIG:SOUR EXT.</p>

-226	Lists not same length This occurs when <code>SENSE:CORREction:CSET[1] CSET2:STATE</code> is set to ON and the frequency and calibration/offset lists do not correspond in length.
-230	Data corrupt or stale This occurs when a FETC? is attempted and either a reset has been received or the power meter state has changed such that the current measurement is invalidated (for example, a change of frequency setting or triggering conditions).
-230	Data corrupt or stale;Please zero and calibrate Channel A When <code>CAL[1 2]:RCAL</code> is set to ON and the sensor currently connected to channel A has not been zeroed and calibrated, then any command which would normally return a measurement result (for example FETC?, READ?, or MEAS?) will generate this error message.
-230	Data corrupt or stale;Please zero and calibrate Channel B When <code>CAL[1 2]:RCAL</code> is set to ON and the sensor currently connected to channel B has not been zeroed and calibrated, then any command which would normally return a measurement result (for example FETC?, READ?, or MEAS?) will generate this error message.
-230	Data corrupt or stale;Please zero Channel A When <code>CAL[1 2]:RCAL</code> is set to ON and the sensor currently connected to channel A has not been zeroed, then any command which would normally return a measurement result (for example FETC?, READ?, or MEAS?) will generate this error message.
-230	Data corrupt or stale;Please zero Channel B When <code>CAL[1 2]:RCAL</code> is set to ON and the sensor currently connected to channel B has not been zeroed, then any command which would normally return a measurement result (for example FETC?, READ?, or MEAS?) will generate this error message.

-230	Data corrupt or stale;Please calibrate Channel A When CAL[1 2] :RCAL is set to ON and the sensor currently connected to channel B has not been calibrated, then any command which would normally return a measurement result (for example FETC?, READ?, or MEAS?) will generate this error message
-230	Data corrupt or stale;Please calibrate Channel B When CAL[1 2] :RCAL is set to ON and the sensor currently connected to channel B has not been calibrated, then any command which would normally return a measurement result (for example FETC?, READ?, or MEAS?) will generate this error message
-231	Data questionable;CAL ERROR Power meter calibration failed. The most likely cause is attempting to calibrate without applying a 1 mW power to the power sensor.
-231	Data questionable;CAL ERROR ChA Power meter calibration failed on channel A. The most likely cause is attempting to calibrate without applying a 1 mW power to the power sensor.
-231	Data questionable;CAL ERROR ChB Power meter calibration failed on channel B. The most likely cause is attempting to calibrate without applying a 1 mW power to the power sensor.
-231	Data questionable;Input Overload The power input to Channel A exceeds the power sensor's maximum range.
-231	Data questionable;Input Overload ChA The power input to Channel A exceeds the power sensor's maximum range.
-231	Data questionable;Input Overload ChB The power input to Channel B exceeds the power sensor's maximum range.

-231	Data questionable;Lower window log error This indicates that a difference measurement in the lower window has given a negative result when the units of measurement were logarithmic.
-231	Data questionable;Upper window log error This indicates that a difference measurement in the upper window has given a negative result when the units of measurement were logarithmic.
-231	Data questionable;ZERO ERROR Power meter zeroing failed. The most likely cause is attempting to zero when some power signal is being applied to the power sensor.
-231	Data questionable;ZERO ERROR ChA Power meter zeroing failed on channel A. The most likely cause is attempting to zero when some power signal is being applied to the power sensor.
-231	Data questionable;ZERO ERROR ChB Power meter zeroing failed on channel B. The most likely cause is attempting to zero when some power signal is being applied to the power sensor.
-241	Hardware missing The power meter is unable to execute the command because either no power sensor is connected or it expects an HP E-series power sensor and one is not connected.
-310	System error;Dty Cyc may impair accuracy with ECP sensor This indicates that the sensor connected is for use with CW signals only.
-310	System error;Ch A Dty Cyc may impair accuracy with ECP sensor This indicates that the sensor connected to channel A is for use with CW signals only.

-310	System error;Ch B Dty Cyc may impair accuracy with ECP sensor This indicates that the sensor connected to channel B is for use with CW signals only.
-310	System error;Sensor EEPROM Read Failed - critical data not found or unreadable This indicates a failure with your HP E-series power sensor. Refer to your power sensor manual for details on returning it for repair.
-310	System error;Sensor EEPROM Read Completed OK but optional data block(s) not found or unreadable This indicates a failure with your HP E-series power sensor. Refer to your power sensor manual for details on returning it for repair.
-310	System error;Sensor EEPROM Read Failed - unknown EEPROM table format This indicates a failure with your HP E-series power sensor. Refer to your power sensor manual for details on returning it for repair.
-310	System error;Sensor EEPROM < > data not found or unreadable Where < > refers to the sensor data block covered, for example, Linearity, Temp - Comp (temperature compensation). This indicates a failure with your HP E-series power sensor. Refer to your power sensor manual for details on returning it for repair.
-310	System error;Sensors connected to both front and rear inputs. You cannot connect two power sensors to the one channel input. In this instance the power meter detects power sensors connected to both it's front and rear channel inputs.
-321	Out of memory The power meter required more memory than was available to run an internal operation.

-330	Self-test Failed; The -330, “Self-test Failed” errors indicate that you have a problem with your power meter. Refer to see Contacting Agilent Technologies on page 226 for details of what to do with your faulty power meter.
-330	Self-test Failed;Measurement Channel Fault Refer to see Measurement Assemblies on page 208 if you require a description of the Measurement Assembly test.
-330	Self-test Failed;Measurement Channel A Fault Refer to see Measurement Assemblies on page 208 if you require a description of the Measurement Assembly test.
-330	Self-test Failed;Measurement Channel B Fault Refer to see Measurement Assemblies on page 208 if you require a description of the Measurement Assembly test.
-330	Self-test Failed;Lithium Battery Fault Refer to see Lithium Battery on page 208 if you require a description of the battery test.
-330	Self-test Failed;Calibrator Fault Refer to see Calibrator on page 209 if you require a description of the calibrator test.
-330	Self-test Failed;ROM Check Failed Refer to see ROM Checksum on page 208 if you require a description of the ROM Checksum test.
-330	Self-test Failed;RAM Check Failed Refer to see RAM on page 208 if you require a description of the RAM test.
-330	Self-test Failed;Display Assy. Fault Refer to see Display on page 209 if you require a description of the Display test.

-330	Self-test Failed;Serial Interface Fault Refer to see Serial Interface on page 209 if you require a description of this test.
-350	Queue overflow The error queue is full and another error has occurred which could not be recorded.
-361	Parity error in program The serial port receiver has detected a parity error and consequently, data integrity cannot be guaranteed.
-362	Framing error in program The serial port receiver has detected a framing error and consequently, data integrity cannot be guaranteed.
-363	Input buffer overrun The serial port receiver has been overrun and consequently, data has been lost.
-410	Query INTERRUPTED A command was received which sends data to the output buffer, but the output buffer contained data from a previous command (the previous data is not overwritten). The output buffer is cleared when power has been off, or after *RST (reset) command has been executed.
-420	Query UNTERMINATED The power meter was addressed to talk (that is, to send data over the interface) but a command has not been received which sends data to the output buffer. For example you may have executed a CONFIGure command (which does not generate data) and then attempted to read data from the remote interface.
-430	Query DEADLOCKED A command was received which generates too much data to fit in the output buffer and the input buffer is also full. Command execution continues but data is lost.

-440

Query UNTERMINATED after indefinite response

The *IDN? command must be the last query command within a command string.

Operator Maintenance

This section describes how to replace the power line fuse and clean the power meter. If you need additional information about replacing parts or repairing the power meter, refer to the EPM-P series power meter *Service Guide*.

To clean the power meter, disconnect its supply power and wipe with a damp cloth only.

The power line fuse is located within the power meter's fuse holder assembly on the rear panel. For all voltages the power meter uses a 250 V, F3.15AH, 20mm fast blow fuse with high breaking capacity (Agilent part number 2110-0957).

NOTE The power meter also has an internal fuse. If you suspect that this fuse needs replaced it must be done by trained service personnel. Please refer to *Returning Your Power Meter for Service* on page 230.

Replacing the Power Line Fuse

- 1 Remove the power cord from the power meter.
- 2 Slide the fuse holder assembly from the rear panel as shown in 4.
- 3 Install the correct fuse in the "In line" position as shown in 4. (A spare fuse can be stored in the fuse holder assembly.)

- 4 Replace the fuse holder assembly in the rear panel.

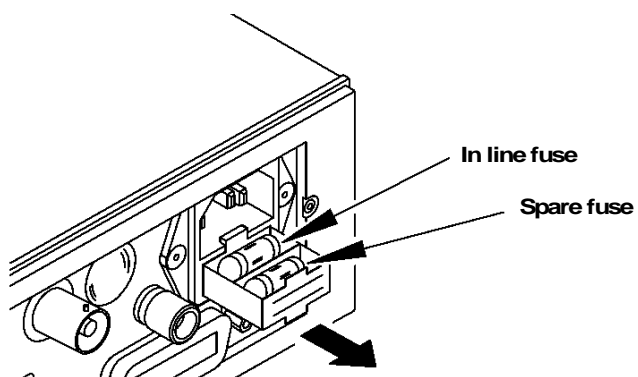

Figure 100 Replacing the Fuse

Contacting Agilent Technologies

This section details what to do if you have a problem with your power meter.

If you have a problem with your power meter, first refer to the section “Before calling Agilent Technologies”. This chapter contains a checklist that will help identify some of the most common problems.

If you wish to contact Agilent Technologies about any aspect of the power meter, from service problems to ordering information, refer to see Sales and Service Offices on page 229.

If you wish to return the power meter to Agilent Technologies refer to see Returning Your Power Meter for Service on page 230.

Before calling Agilent Technologies

Before calling Agilent Technologies or returning the power meter for service, please make the checks listed in see Check the Basics on page 226. If you still have a problem, please read the warranty printed at the front of this guide. If your power meter is covered by a separate maintenance agreement, please be familiar with the terms.

Agilent Technologies offers several maintenance plans to service your power meter after warranty expiration. Call your Agilent Technologies Sales and Service Center for full details.

If the power meter becomes faulty and you wish to return the faulty instrument, follow the description on how to return the faulty instrument in the section see Sales and Service Offices on page 229.

Check the Basics

Problems can be solved by repeating what was being performed when the problem occurred. A few minutes spent in performing these simple checks may eliminate time spent waiting for instrument repair. Before calling Agilent Technologies or returning the power meter for service, please make the following checks:

- Check that the line socket has power.
- Check that the power meter is plugged into the proper ac power source.
- Check that the power meter is switched on.
- Check that the line fuse is in working condition.
- Check that the other equipment, cables, and connectors are connected properly and operating correctly.
- Check the equipment settings in the procedure that was being used when the problem occurred.
- Check that the test being performed and the expected results are within the specifications and capabilities of the power meter.
- Check the power meter display for error messages.
- Check operation by performing the self tests.
- Check with a different power sensor.

Instrument serial numbers

Agilent Technologies makes frequent improvements to its products to enhance their performance, usability and reliability. Agilent Technologies service personnel have access to complete records of design changes for each instrument. The information is based on the serial number and option designation of each power meter.

Whenever you contact Agilent Technologies about your power meter have a complete serial number available. This ensures you obtain the most complete and accurate service information. The serial number can be obtained by:

- interrogating the power meter over the GPIB using the *IDN? command.
- from the front panel by selecting **System**, **More**, **Service**, **Version**.
- from the serial number label.

The serial number label is attached to the rear of each Agilent Technologies instrument. This label has two instrument identification entries. The first provides the instruments serial number and the second provides the identification number for each option built into the instrument.

The serial number is divided into two parts: the prefix (two letters and the first four numbers), and the suffix (the last four numbers).

- The prefix letters indicate the country of manufacture. This code is based on the ISO international country code standard, and is used to designate the specific country of manufacture for the individual product. The same product number could be manufactured in two different countries. In this case the individual product serial numbers would reflect different country of manufacture codes. The prefix also consists of four numbers. This is a code identifying the date of the last major design change.
- The suffix indicates an alpha numeric code which is used to ensure unique identification of each product throughout Agilent Technologies.

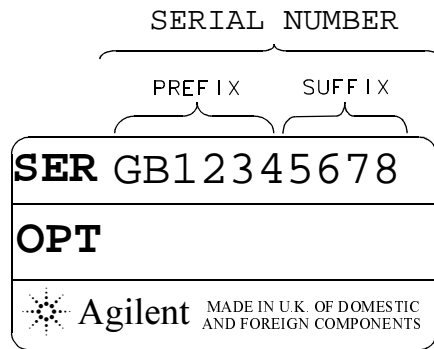

Sales and Service Offices

For more information about Agilent Technologies test and measurement products, applications, services, and for a current sales office listing, visit our web site: <http://www.agilent.com>

You can also contact one of the following centers and ask for a test and measurement sales representative.

UNITED STATES	Agilent Technologies (tel) 1 800 452 4844
CANADA	Agilent Technologies Canada Inc. Test & Measurement (tel) 1 877 894 4414
EUROPE	Agilent Technologies Test & Measurement European Marketing Organization (tel) (31 20) 547 2000
JAPAN	Agilent Technologies Japan Ltd. (tel) (81) 426 56 7832 (fax) (81) 426 56 7840
LATIN AMERICA	Agilent Technologies Latin America Region Headquarters, USA (tel) (305) 267 4245 (fax) (305) 267 4286
AUSTRALIA and NEW ZEALAND	Agilent Technologies Australia Pty Ltd. (tel) 1-800 629 4852 (Australia) (fax) (61 3) 9272 0749 (Australia) (tel) 0-800 738 378 (New Zealand) (fax) (64 4) 802 6881 (New Zealand)
ASIA PACIFIC	Agilent Technologies, Hong Kong (tel) (852) 3197 7777 (fax) (852) 2506 9284

In any correspondence or telephone conversations, refer to the power sensor by its model number and full serial number. With this information, the Agilent Technologies representative can quickly determine whether your unit is still within its warranty period.

Returning Your Power Meter for Service

Use the information in this section if you need to return your power meter to Agilent Technologies.

Package the Power Meter For Shipment

Use the following steps to package the power meter for shipment to Agilent Technologies for service:

- 1 Fill in a blue service tag (available at the end of this guide) and attach it to the power meter. Please be as specific as possible about the nature of the problem. Send a copy of any or all of the following information:
 - Any error messages that appeared on the power meter display.
 - Any information on the performance of the power meter.

CAUTION

Power meter damage can result from using packaging materials other than those specified. Never use styrene pellets in any shape as packaging materials. They do not adequately cushion the power meter or prevent it from shifting in the carton. Styrene pellets cause power meter damage by generating static electricity and by lodging in the rear panel.

- 2 Use the original packaging materials or a strong shipping container that is made of double-walled, corrugated cardboard with 159 kg (350 lb) bursting strength. The carton must be both large enough and strong enough to accommodate the power meter and allow at least 3 to 4 inches on all sides of the power meter for packing material.
- 3 Surround the power meter with at least 3 to 4 inches of packing material, or enough to prevent the power meter from moving in the carton. If packing foam is not available, the best alternative is SD-240 Air Cap™ from Sealed Air Corporation (Commerce, CA 90001). Air Cap looks like a plastic sheet covered with 1-1/4 inch air filled bubbles. Use the pink Air Cap to reduce static electricity. Wrap the power meter several times in the material to both protect the power meter and prevent it from moving in the carton.

- 4 Seal the shipping container securely with strong nylon adhesive tape.
5. Mark the shipping container “FRAGILE, HANDLE WITH CARE” to ensure careful handling.
6. Retain copies of all shipping papers.



8 Specifications and Characteristics

What You'll Find in This Chapter

This Chapter describes the Specifications and Characteristics of your EPM-P series power meter.

It contains the following sections:

- Power Meter Specifications on page 235
 - Measurement Characteristics on page 240
 - Environmental Specifications on page 244
 - Environmental Specifications on page 244
-

Introduction

This chapter details the power meter's specifications and supplemental characteristics.

Specifications - describe the warranted performance and apply after a 30 minute warm-up. These specifications are valid over the power meter's operating and environmental range unless otherwise stated and after performing a zero and calibration procedure.

Supplemental characteristics - *shown in italics*, are intended to provide information useful in applying the power meter by giving typical (expected), but nonwarranted performance parameters. These characteristics are shown in italics or denoted as "typical", "nominal" or "approximate".

Measurement uncertainties - for information on measurement uncertainty calculations, refer to Agilent Application Note 64-1, "Fundamentals of RF and Microwave Power Measurements", Literature Number 5965-6380E.

Compatibility - the EPM-P series power meters operate with the E-series E9320 family of power sensors for peak, average and time gated measurements. The EPM-P series meters also operate with existing 8480 series, E-series E4410 and E9300 ranges of power sensors for average power measurements.

Measurement Modes - the EPM-P series power meters have two measurement modes:

- *Normal mode* - (default mode using E-series E9320 sensors) for peak, average and time related measurements.
- *Average-only mode* - this mode is primarily for average power measurements on low level signals, when using E-series E9320 sensors, and is the mode used with 8480 series and E-series E4410 and E9300 ranges of power sensors.

Power Meter Specifications

Frequency Range

9 kHz to 110 GHz, power sensor dependent

Power Range

-70 dBm to +44 dBm (100 pW to 25 W), power sensor dependent

Power Sensors

Compatible with all Agilent 8480 series power sensors and Agilent E-series power sensors.

Single Sensor Dynamic Range

E-series E9320 peak and average sensors:

70 dB maximum (*Normal mode*)

85 dB maximum (*Average-only mode*)

E-series 4410 sensors:

90dB

E-series E9300 average sensors:

80dB maximum

8480 series sensors:

50 dB maximum

Display Units

Absolute: Watts or dBm

Relative: Percent or dB

Display Resolution

Selectable resolution of:

1.0, 0.1, 0.01 and 0.001 dB in logarithmic mode, or

1, 2, 3 and 4 significant digits in linear mode

Default Resolution

0.01 dB in logarithmic mode

3 digits in linear mode

Offset Range

± 100 dB in 0.001 dB increments, to compensate for external loss or gain.

Video Bandwidth (Modulation Bandwidth)

5 MHz (set by meter and is sensor dependent)

NOTE The video bandwidth represents the ability of the power sensor and meter to follow the power envelope of the input signal. The power envelope of the input signal is, in some cases, determined by the signal's modulation bandwidth, and hence video bandwidth is sometimes referred to as modulation bandwidth.

Video Bandwidth/ Dynamic Range Optimization

The power measurement system, comprising the sensor and meter, has its maximum video bandwidth defined by the E-series E9320 power sensor. To optimize the system's dynamic range for peak power measurements, the Video Bandwidth in the meter can be set to **High**, **Medium**, or **Low** as detailed in Table 101. The filter video bandwidths stated in the table are not the 3 dB bandwidth as the video bandwidths are corrected for optimal flatness. Refer to the E-Series E9320 power sensor *Operating and Service Guide* for information on the sensor's peak flatness response. A filter **Off** mode is also provided.

Figure 101 Video Bandwidth vs. Peak Power Dynamic Range

Sensor	<i>Video Bandwidth / Maximum Peak Power Dynamic Range</i>			
	<i>Off</i>	<i>High</i>	<i>Medium</i>	<i>Low</i>
E9321A E9325A	300 kHz/ -40 dBm to +20 dBm	300 kHz/ -42 dBm to +20 dBm	100 kHz/ -43 dBm to +20 dBm	30 kHz/ -45 dBm to +20 dBm
E9322A E9326A	1.5 MHz/ -36dBm to +20 dBm	1.5 MHz/ -37 dBm to +20 dBm	300 kHz/ -38 dBm to +20 dBm	100 kHz/ -39 dBm to +20 dBm
E9323A E9327A	5 MHz/ -32 dBm to +20 dBm	5 MHz/ -32 dBm to +20 dBm	1.5 MHz/ -34 dBm to +20 dBm	300 kHz/ -36 dBm to +20 dBm

Accuracy

Instrumentation

Please add the corresponding power sensor linearity percentage (Refer to the Specifications section in the User's Guide supplied with your power sensor).

(Average-only Mode):

Absolute:	Logarithmic ± 0.02 dB
	Linear $\pm 0.5\%$
Relative:	Logarithmic ± 0.04 dB
	Linear $\pm 1.0\%$

	Calibration Temperature ¹ ± 5 °C	Temperature 0 to 55°C
Absolute accuracy (log)	± 0.04 dB	± 0.08 dB
Absolute accuracy (linear)	$\pm 0.8\%$	$\pm 1.7\%$
Relative accuracy (log)	± 0.08 dB	± 0.16 dB
Relative accuracy (linear)	$\pm 1.6\%$	$\pm 3.4\%$

¹ Power meter is within ± 5 °C of its calibration temperature.

Time Base: 0.01%

Zero Set, Zero Drift, and Measurement Noise:

For E-series E9320 sensors, refer to the Specifications Section in the *E-series E9320 power sensors Operating and Service Guide*.

1 mW Power Reference

Power Output:	1.00 mW (0.0 dBm). Factory set to $\pm 0.5\%$
	traceable to the US National Institute of Standards and Technology (NIST), and National Physical Laboratories (NPL), UK.
Accuracy: (for one year)	$\pm 1.2\%$ (0 to 55 °C)
	$\pm 1.07\%$ (25 \pm 10 °C)
	$\pm 1.03\%$ (23 \pm 3 °C)
Frequency:	50 MHz nominal
SWR:	1.06 maximum (1.08 maximum for option 003)
Connector Type:	Type N (f), 50 ohms

Measurement Characteristics

Measurement Characteristics:

Measurements: Average Power
 Peak Power
 Peak-to-Average ratio
 Measurements between two time offsets (time gating)

Averaging: Averaging over 1 to 1024 readings
 is available for reducing noise

Measurement Speed (GPIB):

Over the GPIB, three measurement modes are available - Normal, X2 and Fast. The typical maximum speed for each mode is shown in the table below:

Sensor Type		Measurement Speed (readings per second)		
		Normal	x2	Fast ^{1,2}
E-Series E9320 peak and average sensors	Average-only mode	20	40	400
	Normal mode ³	20	40	1000
E-series E4410 and E-series E9300 average power sensors		20	40	400
8480 series Power sensors		20	40	N.A.

¹ Fast speed not available for 8480 series sensors.

² Maximum measurement speed is obtained by using binary output in free run trigger mode.

³ For E-series E9320 sensors maximum speed is achieved using binary output in free run acquisition.

Channel Functions: A, B, A/B, B/A, A-B, B-A, and relative

Storage Registers: 10 instrument states can be saved via Save/Recall menu.

Predefined setups: For common wireless standards (GSM900, EDGE, NADC, iDEN, Bluetooth, IS-95 CDMA, WCDMA and cdma2000), predefined setups are provided.

Trigger

Sources: Internal, External TTL, GPIB, and RS232/422.

Time Resolution: 50 ns

Delay Range: ± 1.0 s

Delay Resolution: 50 ns for delays $\leq \pm 50$ ms otherwise 200 ns

Hold-off: **Range:** 1 μ s to 400 ms

Resolution: 1% of selected value (minimum of 100 ns)

Internal Trigger: **Range:** -20 to +20 dBm

Level Accuracy: ± 0.5 dB

Resolution: 0.1 dB

Latency: 500 ns ± 100 ns

Latency is defined as the delay between the applied RF crossing the trigger level and the power meter switching into the triggered state.

External Trigger Range: High > 2.0 V, Low < 0.8 V; BNC connector; rising or falling edge triggered; input impedance > 1 k Ω

Trigger Out: Output provides TTL compatible levels (High > 2.4 V, Low < 0.4 V) and uses a BNC connector

Sampling Characteristics

Sampling Rate:	<i>20 Msamples/second</i>
Sampling Technique:	<i>continuous sampling</i>

Rear Panel Inputs/Outputs

Recorder Output(s): Analog 0 to 1 V, 1 k Ω output impedance, BNC connector. (Two outputs are available on the E4417A, Channel A and B.)

Remote Input/Output: **TTL Output:** used to signal when measurement has exceeded a defined limit

TTL Input: initiates zero and calibration routine

Connector type: RJ-45 series shielded modular jack assembly

TTL Output: *high=4.8V max, low=0.2V max*

TTL Input: *high=3.5V min., 5V max; low=1Vmax, -0.3V min.*

RS-232/422 Interface: Serial interface for communication with an external controller, Male/Plug 9 pin D-subminiature connector

Trigger In: Accepts a TTL signal for initiating measurements, BNC connector

Trigger Out: Outputs a TTL signal for synchronizing with external equipment, BNC connector

Ground: Binding post, accepts 4mm plug or bare wire connection

Line Power: **Input Voltage Range:** 85 to 264 Vac, automatic selection

Input Frequency Range: 47 to 440 Hz

Power Requirement: \approx 50 VA (14 Watts)

Remote Programming

Interface:	GPIB interface operates to IEEE 488.2 and IEC-625 RS-232 and RS-422 interfaces are supplied as standard
Command Language:	SCPI standard interface commands
GPIB Compatibility:	SH1, AH1, T6, TE0, L4, LE0, SR1, RL1, PP1, DC1, DT1, C0

Physical Specifications

Dimensions:

The following dimensions exclude front and rear panel protrusions:
212.6 mm W x 88.5 mm H x 348.3 mm D
(8.5 in x 3.5 in x 13.7 in)

Weight (Net):	E4416A: 4.0 Kg (8.8 lb) <i>approximately</i>
	E4417A: 4.1 Kg (9.0 lb) <i>approximately</i>
Weight (Shipping):	E4416A: 7.9 Kg (17.4 lb) <i>approximately</i>
	E4417A: 8.0 Kg (17.6 lb) <i>approximately</i>

Environmental Specifications

Operating Environment

Temperature:	0°C to 55°C
Maximum Humidity:	95% at 40°C (non-condensing)
Minimum Humidity:	15% at 40°C
Maximum Altitude:	3,000 meters (9,840 feet)

Storage Conditions

Storage Temperature:	-20°C to +70°C
Non-Operating Maximum Humidity:	90% at 65°C (non-condensing)
Non-Operating Maximum Altitude:	15,240 meters (50,000 feet)

Regulatory Information

Electromagnetic Compatibility

This product conforms with the protection requirements of European Council Directive 89/336/EEC for Electromagnetic Compatibility (EMC). The conformity assessment requirements have been met using the technical construction file route to compliance, using EMC test specifications EN 55011:1991 (Group 1, Class A) and EN 50082-1:1992. In order to preserve the EMC performance of the product, any cable which becomes worn or damaged must be replaced with the same type and specification.

Product Safety

This product conforms to the requirements of European Council Directive 73/23/EEC, and meets the following safety standards:

IEC61010-1(1990) + A1 (1992) + A2 (1995)/EN 61010-1 (1993)

IEC 825-1(1993)/EN 60825-1 (1994)

Canada / CSA C22.2 No. 1010.1-93

Physical Specifications

Dimensions:

The following dimensions exclude front and rear panel protrusions:

212.6 mm W x 88.5 mm H x 348.3 mm D

(8.5 in x 3.5 in x 13.7 in)

Weight (Net):

approximately

E4417A: 4.1 Kg (9.0 lb) *approximately*

E4416A: 4.0 Kg (8.8 lb)

Weight (Shipping):

approximately

E4417A: 8.0 Kg (17.6 lb) *approximately*

E4416A: 7.9 Kg (17.4 lb)