

HP 461A/462A

461A/462A WIDEBAND AMPLIFIER

OPERATING AND SERVICE MANUAL



HEWLETT  PACKARD



HP 461A/462A



OPERATING AND SERVICE MANUAL

(HP PART NO. 00461-90002)

MODEL 461A/462A
WIDEBAND AMPLIFIER

SERIALS PREFIXED: 606- (461A)
551- (462A)

Appendix C, Manual Backdating Changes,
adapts manual to Serials Prefixed:

418-, 346- (461A)
421-, 414-, and 347- (462A)

Copyright Hewlett-Packard Company 1963
P. O. Box 301, Loveland, Colorado, 80537 U. S. A.

TABLE OF CONTENTS

<p>Section I GENERAL INFORMATION 1-1 1-1. General Information 1-1 1-4. Accessories Available 1-1</p> <p>Section II INSTALLATION 2-1 2-1. Introduction 2-1 2-3. Initial Inspection 2-1 2-5. Power Requirements 2-1 2-7. Grounding Requirements 2-1 2-10. Installation 2-1 2-12. Bench Mounting 2-1 2-14. Rack Mounting 2-1 2-16. Combination Mounting 2-1 2-18. Repackaging for Shipment 2-1</p> <p>Section III OPERATING INSTRUCTIONS 3-1 3-1. Introduction 3-1 3-3. Front and Rear Panel Description 3-1 3-5. Operating Instructions 3-1 3-7. Impedance Matching 3-1 3-9. Cascading Amplifiers 3-1</p> <p>Section IV THEORY OF OPERATION 4-1 4-1. General Description 4-1 4-4. Amplifier Circuits 4-1 4-7. Power Supply 4-1</p> <p>Section V MAINTENANCE 5-1 5-1. Introduction 5-1 5-3. Test Equipment Required 5-1 5-5. Performance Checks 5-1</p>	<p>Section V (Cont'd) 5-8. 500 Kc Gain Check (461A and 462A) 5-1 5-9. Output Voltage Check (461A) 5-1 5-10. Distortion Check (461A) 5-1 5-11. Noise Check (461A and 462A) 5-3 5-12. Low Frequency Response Check 5-3 5-13. High Frequency Response Check (461A) 5-3 5-14. Pulse Response Check (462A) 5-4 5-15. Output Check (462A) 5-4 5-16. Overload Recovery Check (461A/462A) 5-4 5-17. Pulse Decay Check (462A) 5-4 5-18. Panel Removal and Replacement 5-5 5-20. Calibration Procedure 5-5 5-22. Power Supply (461A and 462A) 5-5 5-23. Gain Calibration (461A and 462A) 5-5 5-24. Frequency Response Calibration (461A) 5-6 5-25. Pulse Response Calibration (462A) 5-7 5-30. Troubleshooting Procedure 5-9</p> <p>Section VI REPLACEABLE PARTS 6-1 6-1. Introduction 6-1 6-4. Ordering Information 6-1 6-6. Non-Listed Parts 6-1</p> <p>Appendix A CODE LIST OF MANUFACTURERS</p> <p>Appendix B SALES AND SERVICE OFFICES</p> <p>Appendix C MANUAL BACKDATING CHANGES</p>
---	---

LIST OF TABLES

<p>Number 1-1. Specifications 1-1 5-1. Test Equipment Required 5-0</p>	<p>Number 6-1. Index by Reference Designator 6-2 6-2. Replaceable Parts 6-6</p>
--	---

LIST OF ILLUSTRATIONS

<p>Number 1-1. Hewlett-Packard Model 461A/462A Wideband Amplifier 1-0 3-1. Front and Rear Panel Description 3-0 3-2. Operating Instructions 3-1 3-3. Cascading Amplifier 3-2 3-4. Cascading Amplifier 3-2 4-1. Simplified Block Diagram 4-1 5-1. Gain Check Setup 5-2 5-2. Distortion Check Setup 5-2 5-3. Low Frequency Response Check 5-2 5-4. High Frequency Response Check Setup 5-3</p>	<p>Number 5-5. Pulse Response Check Setup 5-4 5-6. Pulse Overload Recovery Check Setup 5-5 5-7. Panel Removal and Replacement 5-6 5-8. Frequency Response Calibration Setup 5-7 5-9. Frequency Response Calibration of -hp- 461A, Markers at 25, 50, 100, 150 and 200 MHz 5-7 5-10. Input and Output Pulses of Model 462A as photographed on -hp- 185B Sampling Oscilloscope; Sweep Speed is 4 ns/cm 5-7 5-11. Top View 5-8 5-12. Bottom View 5-8</p>
--	---



Model 461A
Wide Band Amplifier

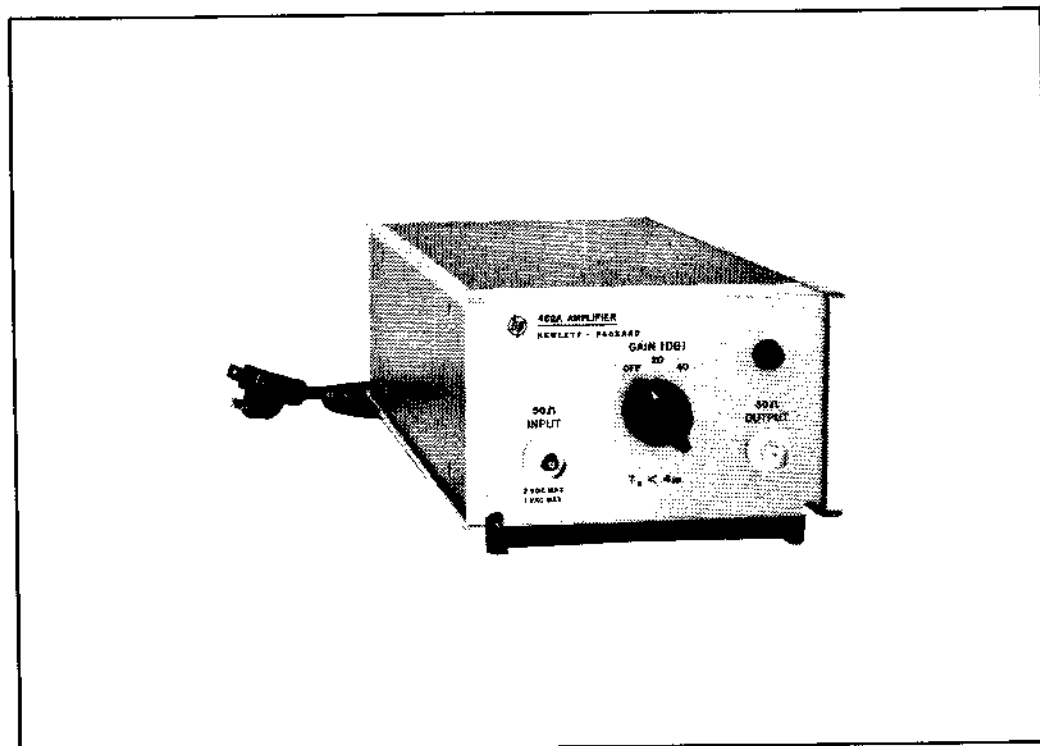

Model 462A
Wide Band Amplifier

Figure 1-1. Hewlett-Packard Model 461A/462A
Wideband Amplifier

SECTION I

GENERAL INFORMATION

1-1. GENERAL INFORMATION.

1-2. The -hp- Models 461A and 462A Wide Band Amplifiers can faithfully amplify both sinusoidal and complex signals in the 1 KHz to 150 MHz range. The Model 461A is best suited for sinusoidal inputs, and the Model 462A is designed for complex and pulse inputs. The Model 461A frequency response is ± 1 db from 1 KHz to 150 MHz. The Model 462A rise and fall times are less than 4 nanoseconds. Either 40 db or 20 db gain can be selected with the front panel GAIN (DB switch). The Models 461A and 462A are shown in Figure 1-1. The specifications of both instruments are given in Table 1-1.

1-3. Since the Models 461A and 462A are nearly identical, this manual will discuss the instruments in terms of the Model 461A. The Model 462A will be mentioned only when its operation differs from that of the Model 461A.

1-4. ACCESSORIES AVAILABLE.

1-5. The -hp- 11048A 50-ohm feedthrough termination is an available accessory that is connected at the output of the Model 461A. The feedthrough termination should be used to ensure that the Model 461A is operating into its rated impedance in the event the instrument is connected to a device with an impedance greater than 50 ohms.

Table 1-1. Specifications

<p>MODEL 461A</p> <p>Frequency Range: 1 KHz to 150 MHz</p> <p>Frequency Response: ± 1 db, 1 KHz to 150 MHz, when operating into a 50-ohm resistive load (500 KHz reference).</p> <p>Gain at 500 KHz: 40 db ± 0.5 db; or 20 db ± 1.0 db, selected by front panel switch. Output is inverted with respect to input.</p> <p>Output: 0.5 ± 0.5 volts rms into 50-ohm resistive load.</p> <p>Distortion: Less than 5% at maximum output and rated load.</p> <p>MODEL 462A</p> <p>Pulse Response:</p> <p>Rise and Fall Time: Less than 4 nanoseconds.</p> <p>Over and Undershoot: Less than 5%.</p> <p>Gain: 40 db or 20 db selected by front panel switch. Output is inverted with respect to input.</p>	<p>Pulse Duration for 10% Droop: 30 μsec.</p> <p>Output: 1 volt peak-to-peak into 50-ohm load.</p> <p>Delay: Nominally 12-14 nanoseconds.</p> <p>GENERAL (461A and 462A)</p> <p>Maximum Input: 1 volt rms or 2 v p-to-p.</p> <p>Maximum DC Input: ± 2 volts.</p> <p>Overload Recovery: Less than 1 μsec for 10 times overload.</p> <p>Equivalent Input Noise Level: Less than 40 microvolts in 40 db position.</p> <p>Input Impedance: 50 ohms, nominal.</p> <p>Power Supply: 115 or 230 v $\pm 10\%$, 50 to 1000 hertz, 5 watts.</p> <p>Dimensions: 3-14/32" (8.7 cm) wide x 11" (27.9 cm) long.</p> <p>Weight: Net: 4 lbs (1.8 Kg). Shipping: 6 lbs (2.7 Kg).</p> <p>Accessory Furnished: Detachable Power Cord</p> <p>Accessory Available: -hp- 11048A 50-ohm through termination.</p>
---	--

SECTION II

INSTALLATION

2-1. INTRODUCTION.

2-2. This section contains information and instructions necessary for the installation and shipping of the Model 461A Amplifier. Included are initial inspection procedures, power and grounding requirements, installation information, and instructions for repackaging for shipment.

2-3. INITIAL INSPECTION.

2-4. This instrument was carefully inspected both mechanically and electrically before shipment. It should be free of marks and scratches and in perfect electrical order upon receipt. To confirm this, the instrument should be inspected for physical damage in transit. Also check for supplied accessories, and test the electrical performance of the instrument using the procedure outlined in Paragraph 5-5. If there is damage or deficiency, see the warranty on the inside front cover of this manual.

2-5. POWER REQUIREMENTS.

2-6. The Model 461A can be operated from any source of 115 or 230 volts ($\pm 10\%$), at 50 to 1000 cycles. With the instrument disconnected from the ac power source, move the 115/230 V slide switch on the rear panel until the desired line voltage appears. Power dissipation is 5 watts maximum.

2-7. GROUNDING REQUIREMENTS.

2-8. To protect operating personnel, the National Electrical Manufacturers' Association (NEMA) recommends that the instrument panel and cabinet be grounded. All Hewlett-Packard instruments are equipped with a three-conductor power cable which, when plugged into an appropriate receptacle, grounds the instrument. The offset pin on the power cable three-prong connector is the ground wire.

2-9. To preserve the protection feature when operating the instrument from a two-contact outlet, use a three-prong to two-prong adapter and connect the green pigtail on the adapter to ground.

2-10. INSTALLATION.

2-11. The Model 461A is fully transistorized; therefore, no special cooling is required. However, the instrument should not be operated where the ambient temperature exceeds 55°C (131°F) or the relative humidity exceeds 95%.

2-12. BENCH MOUNTING.

2-13. The Model 461A is shipped with plastic feet and tilt stand in place, ready for use as a bench instrument.

2-14. RACK MOUNTING.

2-15. The Model 461A may be rack mounted by using an adapter frame (-hp- Part No. 5060-0797). The

adapter frame is a rack frame that accepts any combination of submodular units. It can be rack mounted only. For additional information, address inquiries to your -hp- Sales and Service Office. (See Appendix B for office locations.)

2-16. COMBINATION MOUNTING.

2-17. The Model 461A may be mounted in combination with other submodular units by using a Combining Case (-hp- Model 1051A or 1052A). The Combining Case is a full-module unit which accepts various combinations of submodular units. Being a full-module unit, it can be bench or rack mounted and is analogous to any full-module instrument.

2-18. REPACKAGING FOR SHIPMENT.

2-19. The following paragraphs contain a general guide for repackaging of the instrument for shipment. Refer to Paragraph 2-20 if the original container is to be used; 2-21 if it is not. If you have any questions, contact your local -hp- Sales and Service Office. (See Appendix B for office locations.)

NOTE

If the instrument is to be shipped to Hewlett-Packard for service or repair, attach a tag to the instrument identifying the owner and indicating the service or repair to be accomplished; include the model number and full serial number of the instrument. In any correspondence, identify the instrument by model number, serial number, and serial number prefix.

2-20. If original container is to be used, proceed as follows:

a. Place instrument in original container if available. If it is not available, a suitable container can be purchased from your nearest -hp- Sales and Service Office.

b. Ensure that container is well sealed with strong tape or metal bands.

2-21. If original container is not to be used, proceed as follows:

a. Wrap instrument in heavy paper or plastic before placing in an inner container.

b. Place packing material around all sides of instrument and protect panel face with cardboard strips.

c. Place instrument and inner container in a heavy carton or wooden box and seal with strong tape or metal bands.

d. Mark shipping container with "DELICATE INSTRUMENT," "FRAGILE" etc.

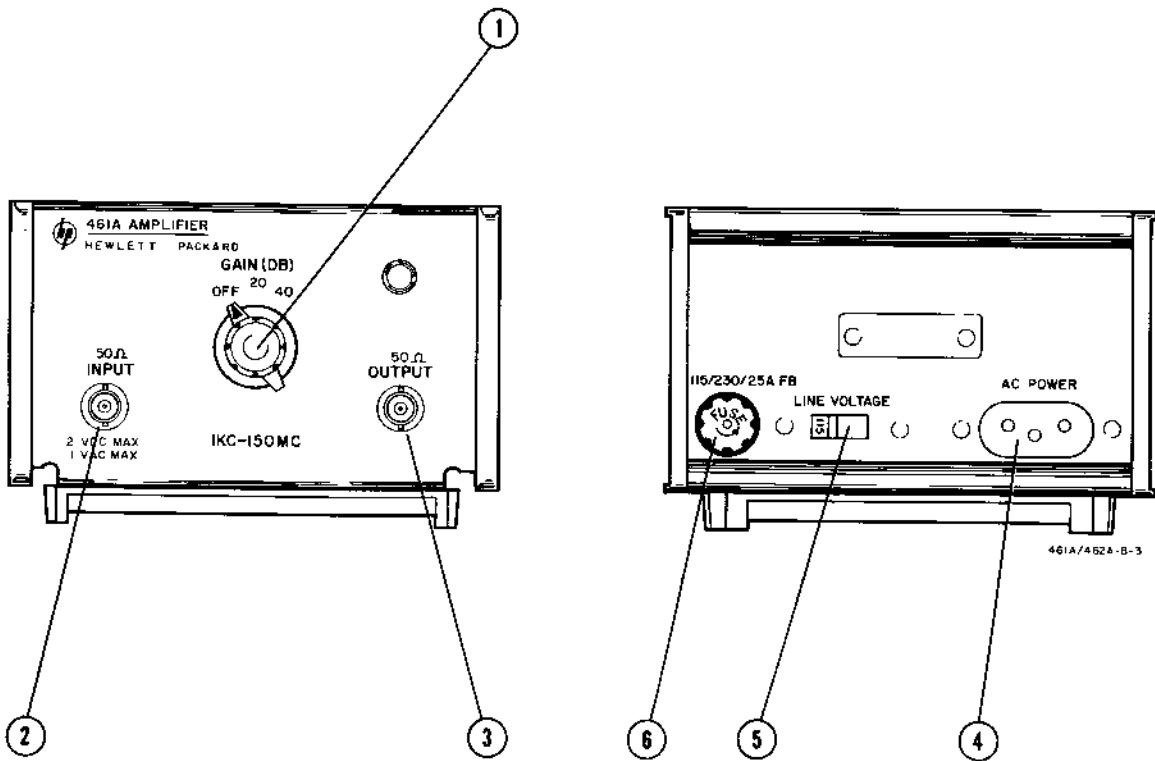

- ① **GAIN (DB) switch:** Applies primary power and selects gain.
- ② **50 Ω INPUT connector:** Connects input signal to the instrument. **DO NOT APPLY MORE THAN 1 VAC OR 2 VDC TO INPUT.**
- ③ **50 Ω OUTPUT connector:** Connects amplified output to load. Output must be terminated in 50 Ω. **VOLTAGE LEVEL AT OUTPUT MUST NOT EXCEED -6 VOLTS DC OR +0.6 VOLTS DC.**

- ④ **AC POWER connector:** Connects primary power to the instrument.
- ⑤ **LINE VOLTAGE:** Selects either 115 volts ac or 230 volts ac primary power.
- ⑥ **Fuseholder:** Contains a 1/4 ampere fast-blow fuse for both 115 and 230 volt operation.

Figure 3-1. Front and Rear Panel Description

SECTION III

OPERATING INSTRUCTIONS

3-1. INTRODUCTION.

3-2. The Model 461A can be used to faithfully amplify signals in the 1 KHz to 150 MHz range. Gain settings of 20 db or 40 db may be selected with the front panel GAIN (DB) switch. The Model 461A will operate within specifications only when its output is terminated in 50 ohms.

3-3. FRONT AND REAR PANEL DESCRIPTION.

3-4. Figure 3-1 describes the function of all the controls and indicators on both the front and rear panel.

3-5. OPERATING INSTRUCTIONS.

3-6. Figure 3-2 contains the operating instructions for the Model 461A. Each instruction is keyed to a drawing of the front panel.

3-7. IMPEDANCE MATCHING.

3-8. Both the input impedance and the output impedance of the Model 461A are 50 ohms. The Model 461A output must be connected to a 50 Ω load if it is to operate within specifications. If the input impedance of the load is not 50 Ω , a terminating impedance of 50 Ω must be connected across the Model 461A output. The -hp- Model 11048A 50 Ω Feedthrough Termination is recommended for this purpose. The Model 11048A may be easily connected in series with the Model 461A output.

3-9. CASCADING AMPLIFIERS.

3-10. The Model 461A will amplify small signals in the 5 to 50 millivolt range to an amplitude of 0.5 volts with minimum distortion. Should larger output signals be desired, the Model 461A can be cascaded with other amplifiers, such as the -hp- Models 460A and 460B. Typical set-ups cascading the Model 461A and Models 460A and 460B are shown in Figures 3-3 and 3-4.

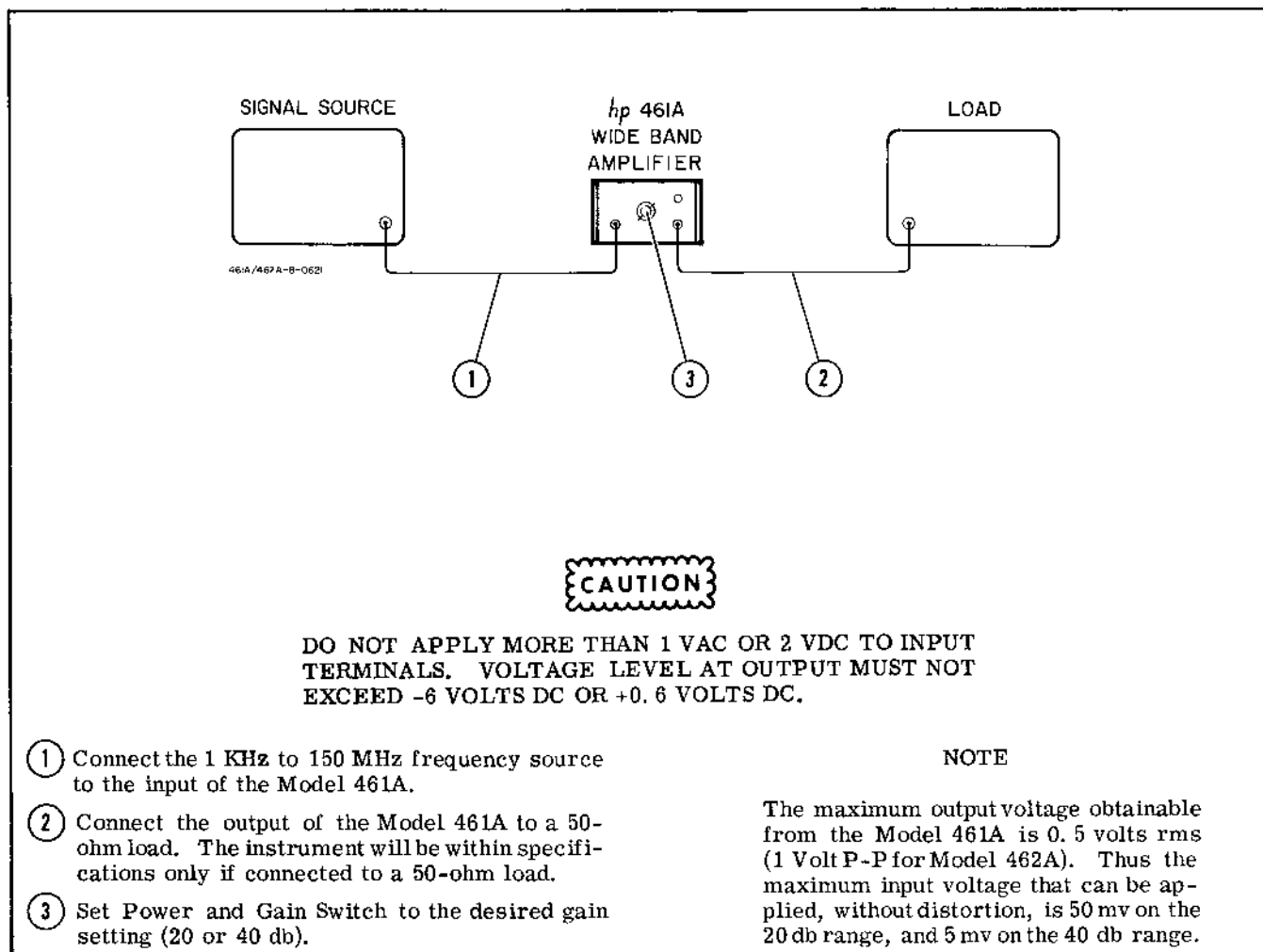

Figure 3-2. Operating Instructions

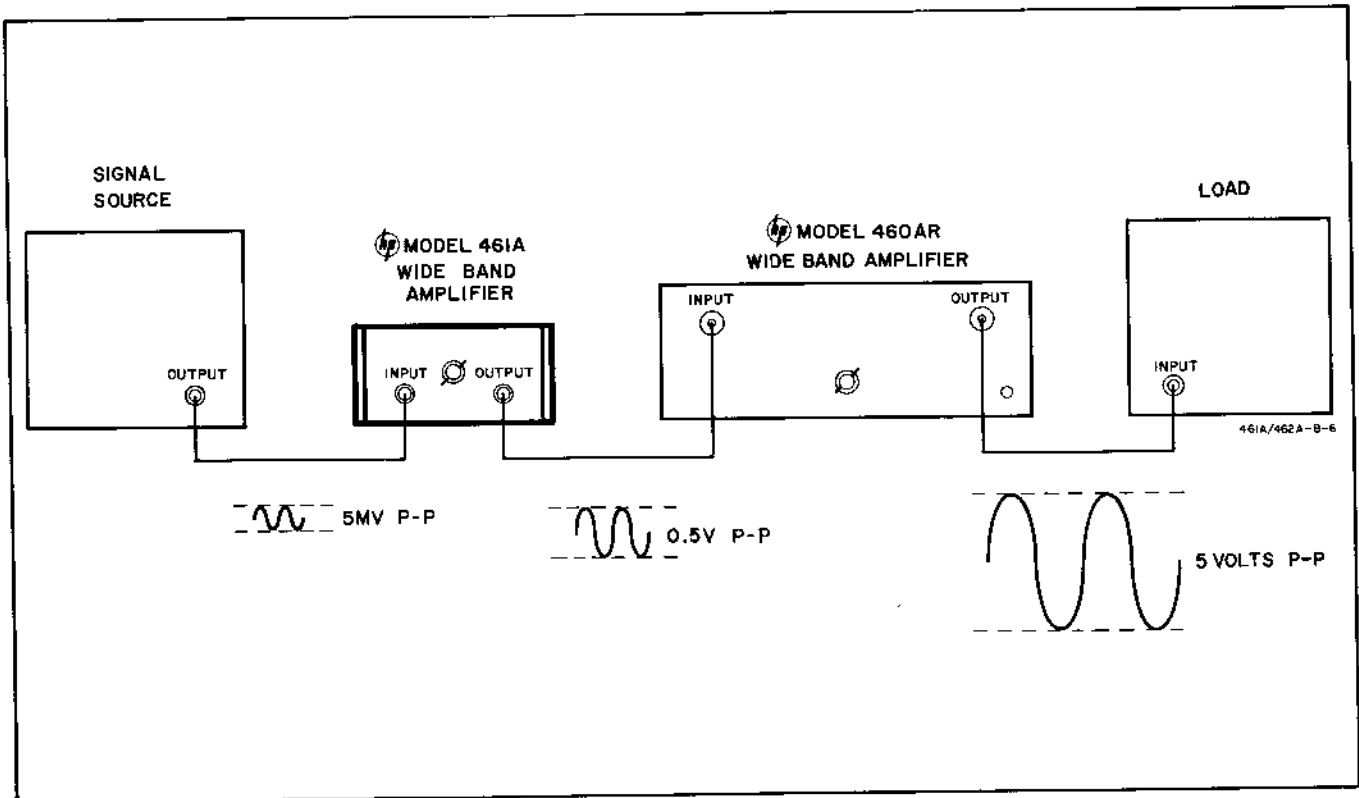

Figure 3-3. Cascading Amplifier

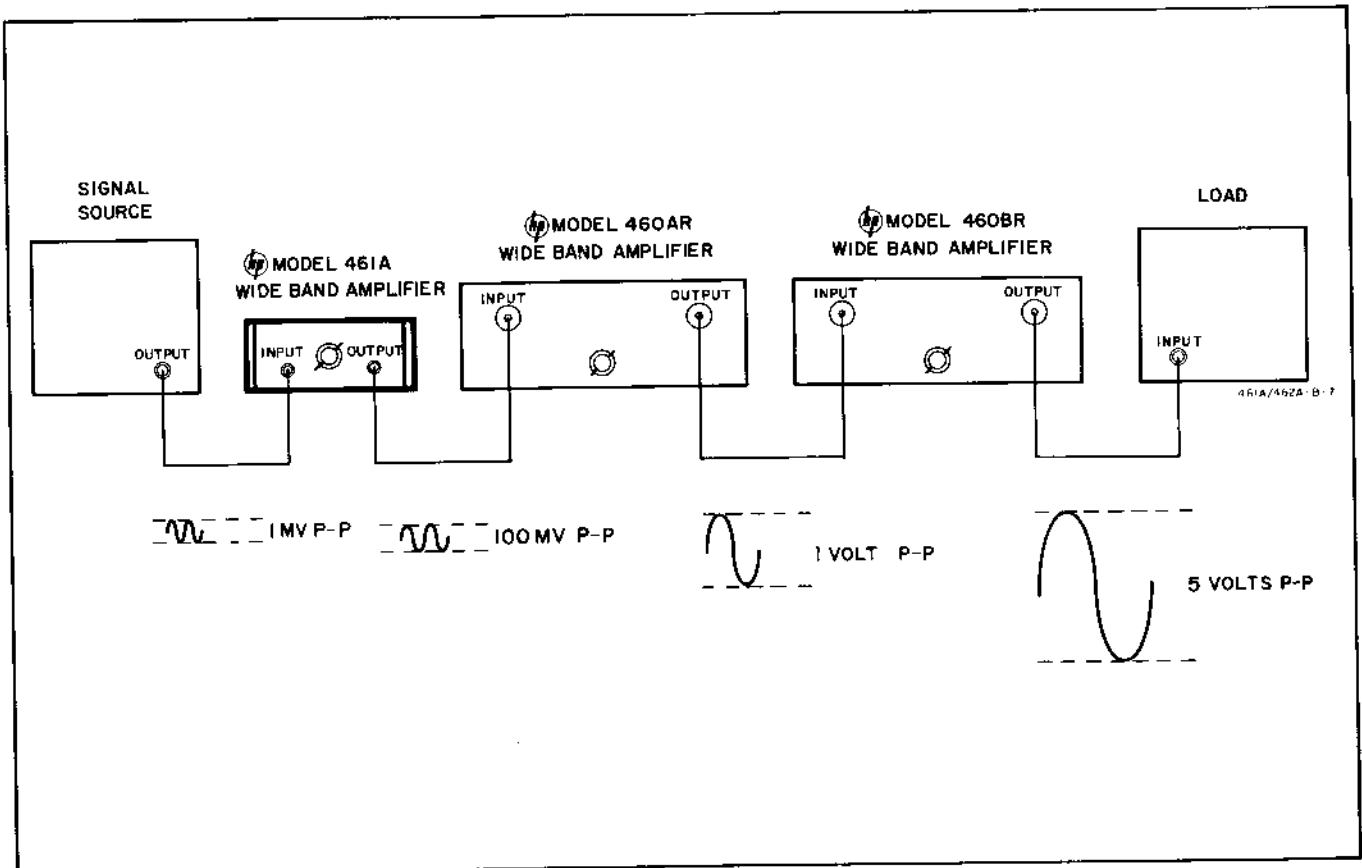

Figure 3-4. Cascading Amplifier

SECTION IV

THEORY OF OPERATION

4-1. GENERAL DESCRIPTION.

4-2. The Models 461A and 462A Amplifiers are essentially identical. In the Model 462A some of the component values are changed slightly to improve its pulse response. In this section both instruments will be presented in terms of the Model 461A.

4-3. Figure 4-1 shows a simplified block diagram of the Model 461A. The amplifier is a five stage, stagger-tuned, cascaded amplifier with emitter follower input and output stages. The gain is switched from 40 db to 20 db by attenuating the input by 20 db. The power supply is a conventional series regulated supply with +15 volt and -15 volt outputs.

4-4. AMPLIFIER CIRCUITS.

4-5. Figure 5-13 shows the schematic diagram of the Model 461A. A3Q3 is the input emitter follower, matching the 50 Ω input impedance to the input impedance of the amplifier. Transistors A3Q4 through

A3Q8 constitute a five stage, RC coupled, cascaded amplifier. Each stage has a gain of 8 db, giving the amplifier a total gain of 40 db.

4-6. Each stage has an LR feedback circuit with an adjustable inductor. The feedback circuit in each stage controls the overall gain of the amplifier at a different frequency, so the amplifier must be stagger-tuned. There is some interaction between the stages at certain frequencies. A3Q9 is the output emitter follower, and it matches the amplifier output to a 50 Ω output impedance.

4-7. POWER SUPPLY.

4-8. The power supply generates +15 volts and -15 volts bias supply to the amplifiers. Breakdown diode A2CR3 establishes a 15 volt reference. Control transistor A2Q2 detects differences between the reference voltage and the supply output, and its output controls the series regulator Q1.

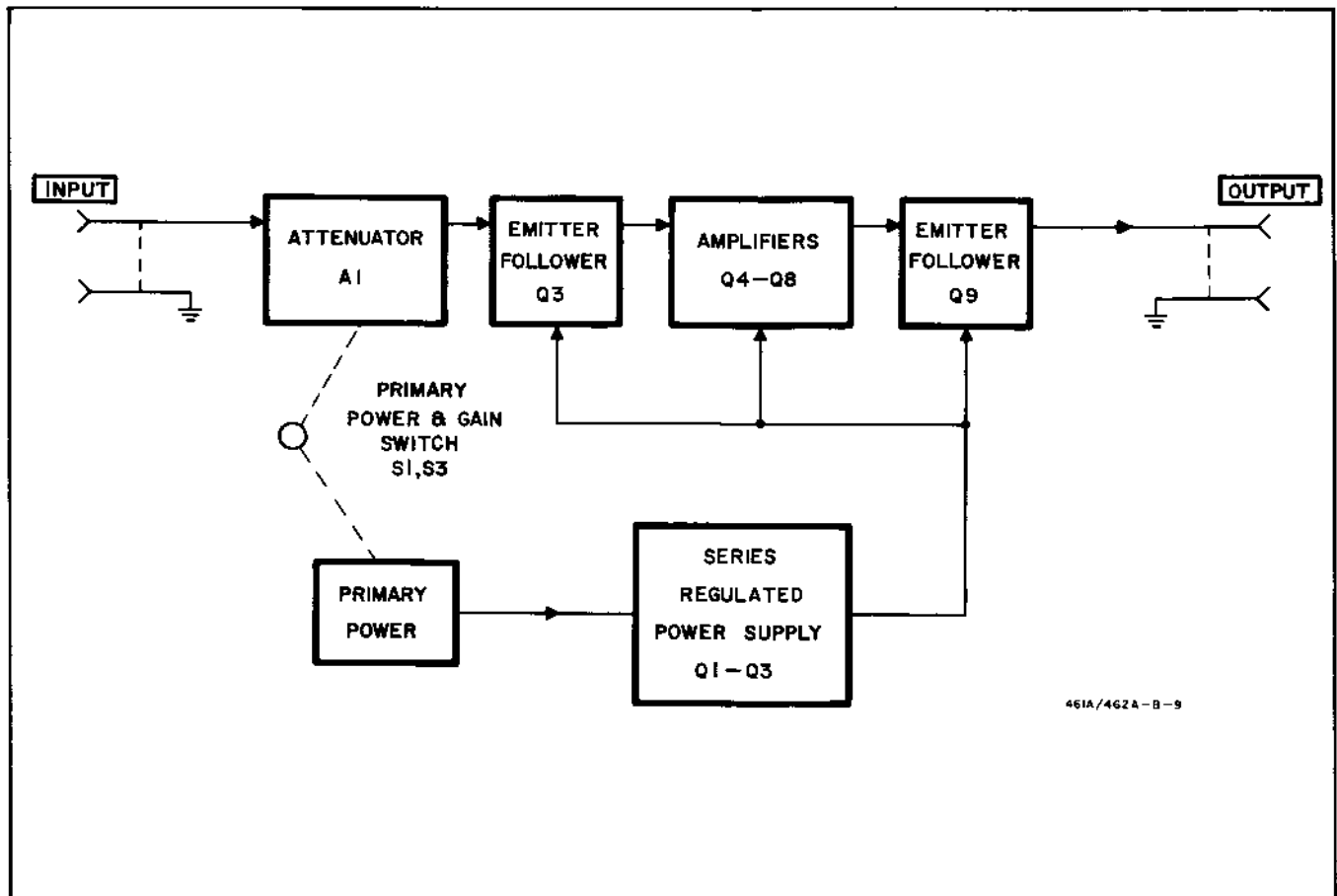

461A/462A-B-9

Figure 4-1. Simplified Block Diagram

Table 5-1. Test Equipment Required

Instrument Type	Critical Specifications	Use	Recommended Model
Wide Range Oscillator	Output: 3 v Impedance: 50 ohms Freq. Range: 5 Hz - 500 KHz Distortion: less than 0.5%	Gain Check	-hp- Model 200SR Wide Range Oscillator
Frequency Response Test Set	Freq. Range: 500 KHz to 10 MHz Freq. Response: Flat within +0.5% - 1.5%, 500 KHz to 10 MHz	Frequency Response Check	-hp- Model 739A Frequency Response Test Set
Logarithmic Vacuum Tube Voltmeter	Accuracy: $\pm 1\%$ at full scale Freq. Range: 10 Hz to 500 KHz DB Range: -60 to +10 db	Gain Check	-hp- Model 400L, Logarithmic Vacuum Tube Voltmeter
Attenuator	Attenuation: 40 db Accuracy: ± 0.1 db Freq. Range: 1 KHz to 150 MHz	Frequency Response and Gain Check	Weinschel 50-40S
Attenuator	Attenuation: 120 db in 10 db steps Freq. Range: 1 KHz to 150 MHz Overall Accuracy: ± 1.5 db Impedance: 50 ohms	Frequency Response and Gain Check	-hp- Model 355D VHF Coaxial Attenuator
Distortion Analyzer	Freq. Range: 20 Hz to 500 KHz Sensitivity: Measure 5% distortion Accuracy: $\pm 3\%$	Distortion Check	-hp- Model 331A Distortion Analyzer
RF Millivoltmeter	Freq. Range: 500 KHz to 150 MHz Accuracy: $\pm 6\%$ full scale DB Range: -30 db to +10 db	Frequency Response Noise Check	-hp- Model 411A RF Millivoltmeter
Multimeter	Accuracy: $\pm 1\%$ full scale Input Resistance: 200 M Ω	Troubleshooting and Power Supply Checks	-hp- Model 412A DC Voltmeter-Ohmmeter-Ammeter
Signal Generator	Freq. Range: 10 MHz - 150 MHz Output: 0.5 v Impedance: 50 ohms	High Frequency Check	-hp- Model 608C/D VHF Signal Generator
Power Meter	Power Range: -30 dbm to +10 dbm Accuracy: $\pm 3\%$ full scale	High Frequency Check	-hp- Model 431A/B Power Meter with -hp- 478A Thermistor Mount
Oscilloscope	Bandwidth: Dc to 200 KHz Sensitivity: 10 mv/cm to 10 v/cm Type: dual trace	Frequency Response Calibration	-hp- Model 122A Dual Track 200 Kc Oscilloscope or -hp- Model 175 Oscilloscope -hp- 1750A and 1780A Plug-in units
Oscilloscope	Bandwidth: 1 KHz to 50 MHz Sensitivity: 0.1 v/cm to 1 v/cm	Pulse Response Check	-hp- Model 175A Oscilloscope
High Frequency Oscilloscope	Bandwidth: 50 MHz to 1 GHz Sensitivity: 200 mv/cm to 5 v/cm	Pulse Response Check and Calibration	-hp- Model 185B 100 Mc Oscilloscope with -hp- 187B Dual Trace Amplifier
Pulse Generator	Impedance: 50 ohms Leading and Trailing Edge: <1 nsec Overshoot and Ringing: <5% peak Corner Rounding Amplitude: <95% of pulse amplitude Pulse Width: 30 nsec	Pulse Response Check and Calibration	-hp- Model 215 Pulse Generator
Pulse Generator	Pulse Width: 1 μ sec Pulse Amplitude: 0.5 v, p-p	Pulse Overload Recovery Check	-hp- Model 212A Pulse Generator
Square Wave Generator	Pulse Width: 30 μ sec Pulse Amplitude: 0.01 v, p-p	Pulse Decay Check	-hp- Model 211A Square Wave Generator

SECTION V MAINTENANCE

5-1. INTRODUCTION.

5-2. This section uses the following sequence: Performance Checks, Cabinet Removal, Calibration Procedure, Troubleshooting, and Repair.

5-3. TEST EQUIPMENT REQUIRED.

5-4. The critical specifications and suggested test equipment needed in the performance and calibration procedures are given in Table 5-1.

5-5. PERFORMANCE CHECKS.

5-6. The performance checks are in-cabinet procedures that are used to check the instrument against its specifications. These procedures can be used as periodic maintenance, after repair or incoming and outgoing quality control checks.

5-7. Checks for the Models 461A and 462A are provided. The heading of each paragraph indicates whether the procedure is applicable to one or both instruments.

5-8. 500 KC GAIN CHECK (461A and 462A).

a. Connect 461A as shown in Figure 5-1 with the ac voltmeter connected to position A.

b. Set the oscillator to 500 KHz with minimum amplitude.

c. Set the coaxial attenuator to 40 db.

d. Set the Model 461A GAIN (DB) control to 40 db.

e. Adjust the oscillator AMPLITUDE control for a -10.0 db indication on the ac voltmeter.

f. Disconnect the ac voltmeter from position A and connect it to position B.

g. The ac voltmeter reading should be -10 db \pm 0.5 db.

h. Rotate 461A GAIN control to 20 db.

i. The ac voltmeter should drop to -30 db \pm 1 db.

5-9. OUTPUT VOLTAGE CHECK (461A).

a. Connect the 461A as shown in Figure 5-1.

b. Set the oscillator frequency to 500 KHz and set its output to minimum. Set the attenuator to 50 db.

c. Connect the ac voltmeter to position A.

d. Adjust the oscillator amplitude for a voltmeter reading of -43.8 db.

e. Set the 461A GAIN (DB) switch to 40 db, and connect the voltmeter to position B.

f. The voltmeter should read -3.8 db \pm 1 db, indicating 40 db \pm 1 db of gain and 0.5 \pm 0.05 volt output.

5-10. DISTORTION CHECK (461A).

a. Connect the 461A as shown in Figure 5-2.

b. Set the oscillator frequency to 500 KHz and amplitude to minimum.

c. Connect the distortion analyzer to voltmeter function and connect it to A.

d. Set the attenuator to 40 db and set the 461A GAIN (DB) to 40 DB.

e. Adjust the oscillator for an indication of 0.5 volts on the distortion analyzer.

Table 5-1. Test Equipment Required (Cont'd)

Instrument Type	Critical Specifications	Use	Recommended Model
50 Ω Feedthru Termination	Resistance: 50 ohms Type: BNC	Performance Check	-hp- 11048A 50 Ω Feedthru Termination
Sweep Generator	Freq. Range: 1 KHz - 200 MHz RF Variation across load: \pm 0.10 db Output: 1 v rms	Frequency Response Calibration	Telonic SM-2000 Sweep/Signal Generator
External Monitor	Freq. Range: 1 KHz to 150 MHz	Frequency Response	Telonic SP1-71
BNC "T" Adapter	UG-274A/U	Gain Check	-hp- Part No. 1250-0072
Type "N" Adapter	UG-349A/U	Frequency Response Check	-hp- Part No. 1250-0077
Type "N"-to-BNC Adapter	UG-201A/A	Frequency Response Check	-hp- Part No. 1250-0067
Male BNC-to-BNC Adapter	UG-491A/U	Frequency Response Check	-hp- Part No. 1250-0216

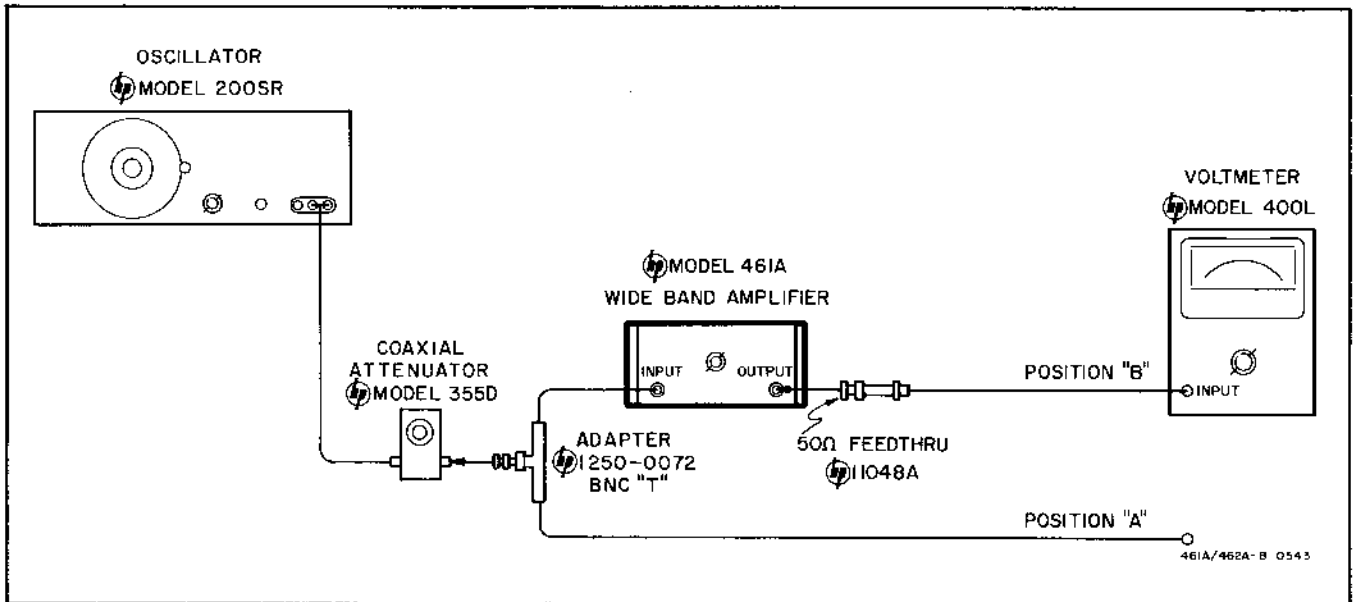

Figure 5-1. Gain Check Setup

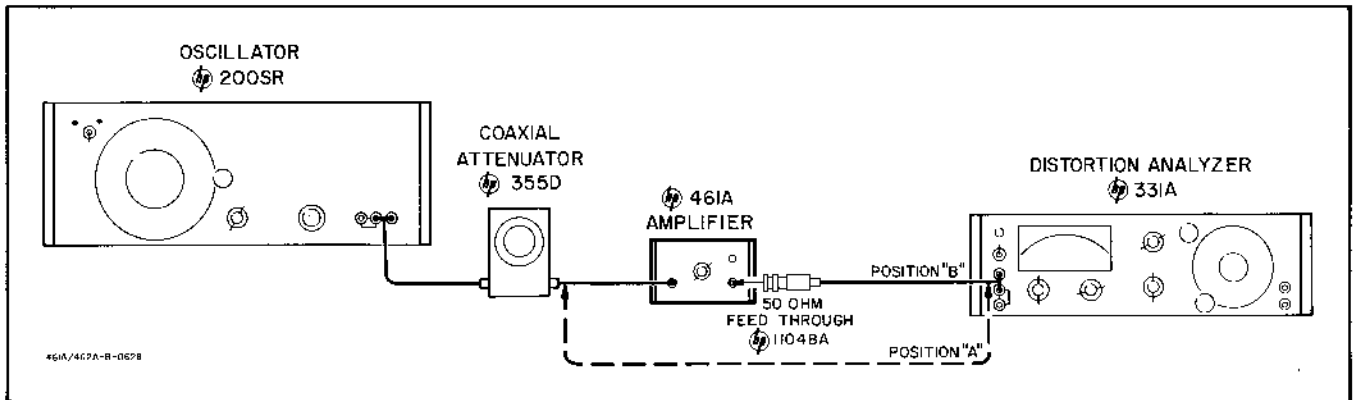

Figure 5-2. Distortion Check Setup

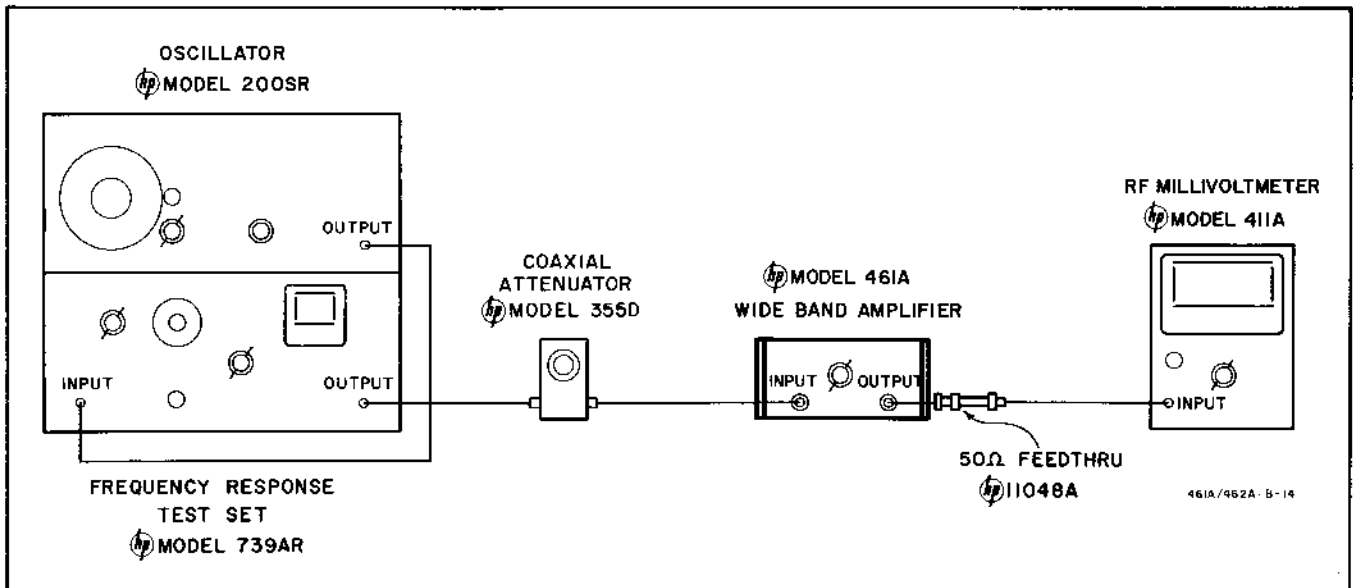

Figure 5-3. Low Frequency Response Check

- f. Measure the distortion at position A.
- g. Measure the distortion at position B. The difference between the two distortion readings should be less than 5%.

5-11. NOISE CHECK (461A and 462A).

- a. Connect RF Millivoltmeter and a 50 ohm load to OUTPUT of Model 461A.
- b. Rotate Model 461A GAIN control to 40 db.
- c. RF Millivoltmeter should indicate less than 4 millivolts.

5-12. LOW FREQUENCY RESPONSE CHECK.

- a. Connect the Model 461A as shown in Figure 5-3.
- b. Set the attenuator to 40 db and set the 461A GAIN (DB) to 40 db.
- c. Adjust the frequency response test set frequency to 500 KHz and adjust its output for an indication of -5 db on the RF millivoltmeter.
- d. Adjust the frequency response test set's set level control for a convenient indication. Record the set level indication.
- e. Change the test set frequency to 10 MHz and readjust the amplitude for the same set level recorded in step d.
- f. The RF millivoltmeter indication should not change by more than ± 1 db.
- g. Repeat steps e and f at frequencies of 5 MHz and 1 MHz.
- h. Use an external oscillator to drive the frequency response test set at 1 KHz, and adjust the amplitude for the set level indication in step d.
- j. Connect a low frequency voltmeter in place of the RF millivoltmeter. The voltmeter should read -5 db ± 1 db.

5-13. HIGH FREQUENCY RESPONSE CHECK (461A).

NOTE

Either Paragraph 5-13, steps a thru m (Figure 5-4), or Paragraph 5-22, steps a thru i (Figure 5-8), can be used for this check.

- a. Connect Model 461A as shown in Figure 5-4.
- b. Set System Attenuator to 40 db.
- c. Rotate Model 461A GAIN (DB) control to 40 db.
- d. Adjust Signal Generator for a frequency of 10 MHz.
- e. Connect Power Meter to OUTPUT of Model 461A (position A in Figure 5-4).
- f. Adjust the Signal Generator output amplitude for an indication of -5 db on Power Meter.
- g. Disconnect Signal Generator from Attenuator.

NOTE

Do not disturb Signal Generator controls.

- h. Connect Power Meter to OUTPUT of Signal Generator; record Power Meter indication for use as a reference.
- j. Adjust signal generator to 20 MHz.
- k. Adjust Signal Generator output level to the level recorded in step h.
- m. Connect Power Meter to Model 461A OUTPUT. Connect OUTPUT of Signal Generator to input of System Attenuator.
- n. Power Meter should indicate -5 db ± 1 db.
- o. Repeat steps g thru o at 50, 100 and 150 MHz.

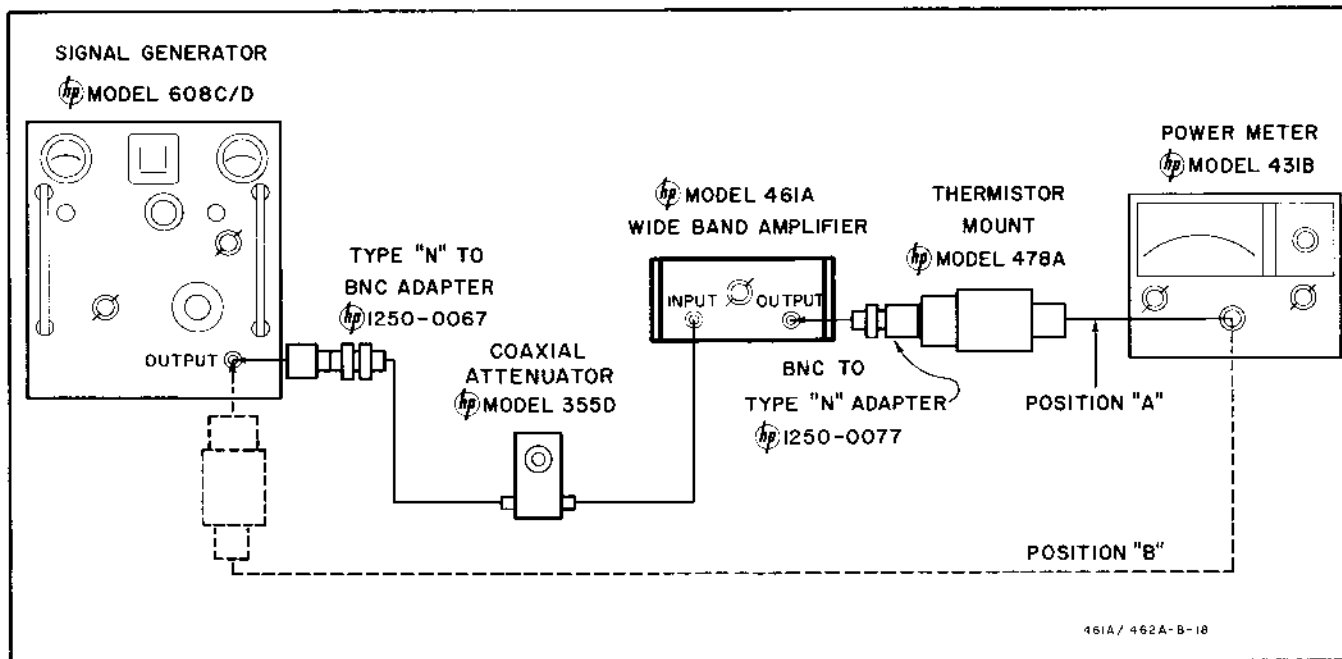

Figure 5-4. High Frequency Response Check Setup

5-14. PULSE RESPONSE CHECK (462A).

- a. Connect the Model 462A as shown in Figure 5-5.
- b. Set attenuator to 50 db.
- c. Set 462A GAIN (DB) control to 40 db.
- d. Set up the pulse generator for a 30 nsec negative pulse at a repetition rate between 0.1 MHz and 1 MHz.
- e. Connect the oscilloscope and 50 Ω load to position B and set the oscilloscope to display one 30 nsec pulse. Observe the shape of the input pulse.
- f. Connect the oscilloscope to position A. The displayed pulse should have the same shape as the pulse observed in step c. The rise and fall times should be less than 4 nsec. Figure 5-10 shows the relative waveshapes.

5-15. OUTPUT CHECK (462A).

- a. Perform procedure described in Paragraph 5-4, steps a thru d.
- b. Connect Oscilloscope (with 50 ohm load) to OUTPUT of System Attenuator (position B in Figure 5-5).
- c. Adjust Amplitude of Pulse Generator for an 0.01 volt peak-to-peak output.
- d. Connect output of System Attenuator to INPUT of Model 462A.
- e. Connect Oscilloscope to OUTPUT of Model 462A. Amplitude of pulse observed on oscilloscope should be 1 volt peak-to-peak $\pm 10\%$, and the pulse should be inverted.

5-16. OVERLOAD RECOVERY CHECK (461A/462A).

- a. Connect a pulse generator (-hp- Model 212A) and an oscilloscope as shown in position A in Figure 5-6.

NOTE

Keep all leads short as possible.

- b. Set pulse length to 1 microsecond. Adjust amplitude of Pulse Generator for a 1.0 v peak-to-peak pulse.

- c. Remove 50 ohm load and connect output of Pulse Generator to Model 461A INPUT.

- d. Connect a 50 ohm load termination and an oscilloscope to Model 461A OUTPUT (position B in Figure 5-6).

- e. The baseline should be restored within 10% in less than 1 microsecond after the trailing edge of PULSE.

5-17. PULSE DECAY CHECK (462A).

- a. Connect a 50 ohm load across output of a Pulse or Square Wave Generator such as the -hp- Model 211A.

- b. Adjust Pulse Generator for a 30 microsecond pulse with amplitude less than 0.01 volt peak-to-peak.

- c. Remove the 50 ohm load from output of Pulse Generator.

- d. Connect output of Pulse Generator to INPUT of Model 462A.

- e. Rotate Model 462A GAIN control to 40 db.

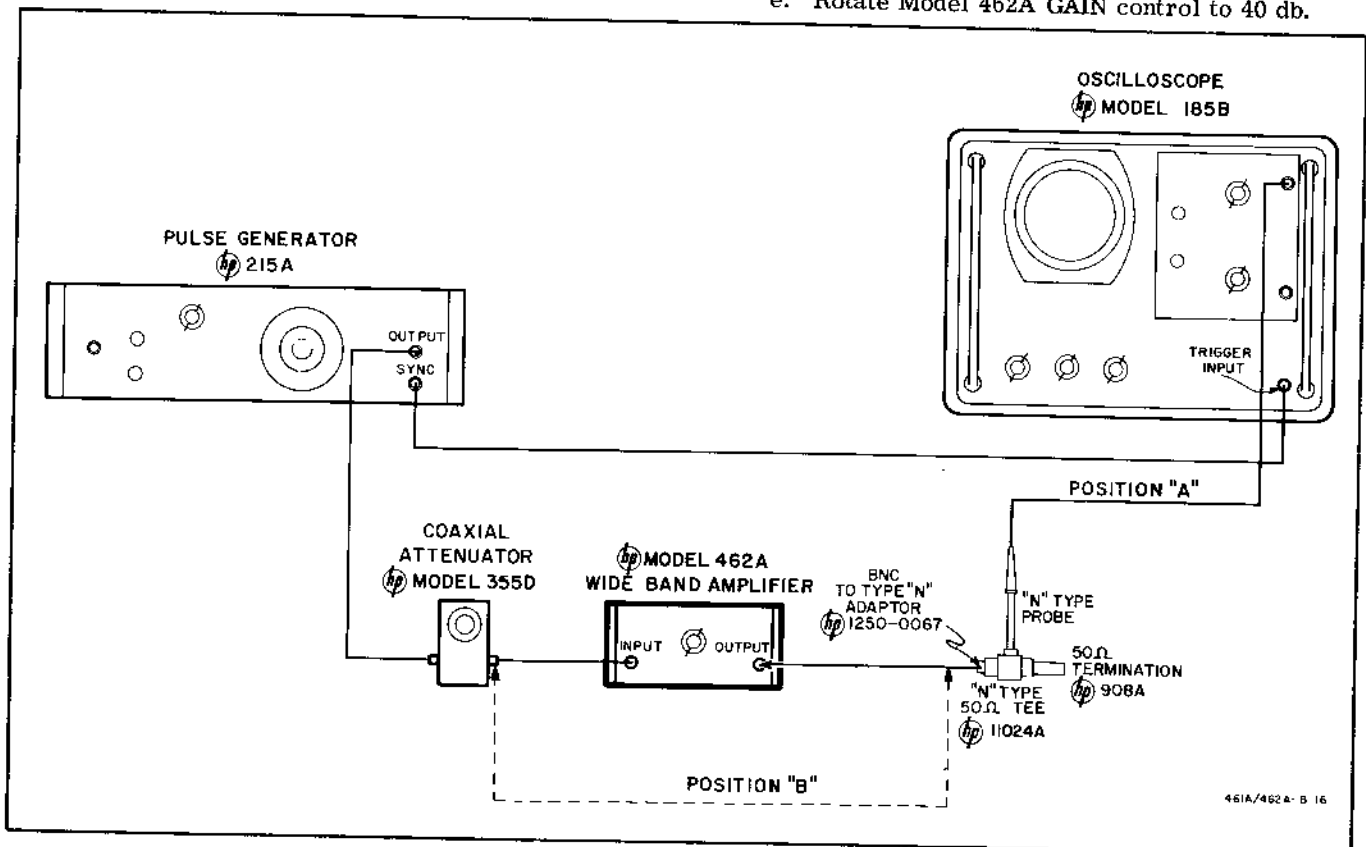

Figure 5-5. Pulse Response Check Setup

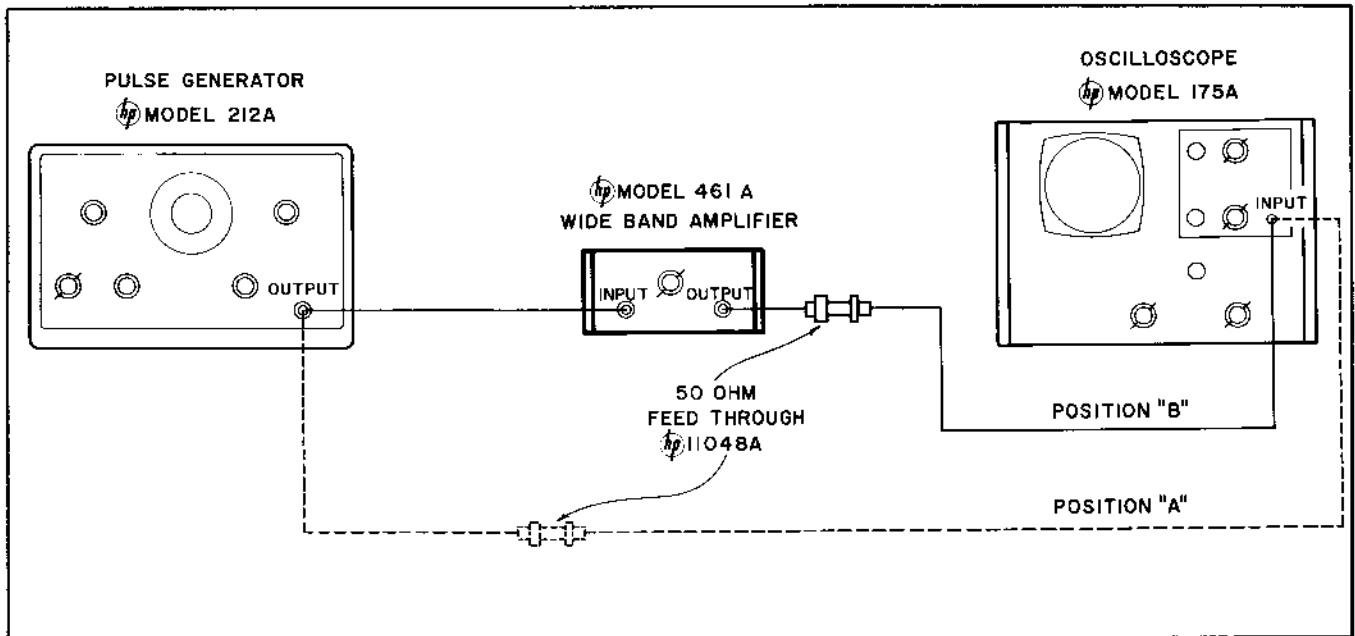

Figure 5-6. Pulse Overload Recovery Check Setup

f. Connect 50 ohm load and Oscilloscope (dc coupled) to OUTPUT of Model 462A.

g. Pulse droop should not exceed 10%.

5-18. PANEL REMOVAL AND REPLACEMENT.

5-19. The Model 461A includes top, bottom and two side panels. For maintenance and calibration, only top or bottom covers need be removed. Side panel removal will be necessary only when replacing front or rear panel etc. Panel removal is illustrated in Figure 5-7.

a. Remove ac power from the Model 461A.

b. Remove the 6/32 screws that hold the panel in place.

c. Remove the panel.

d. When replacing the panel, simply reverse the order.

5-20. CALIBRATION PROCEDURE.

5-21. The following is a complete test and adjustment procedure and should be made only if it has been determined that the -hp- Model 461A is out of adjustment as determined by Paragraph 5-5, Performance Check. Indiscriminate adjustment of the internal controls to "refine" settings may actually cause difficulty. Calibration procedures for the Models 461A and 462A are provided. The heading of each paragraph indicates whether the procedure is applicable to one or both instruments.

5-22. POWER SUPPLY (461A and 462A).

a. Remove top and bottom covers from Model 461A cabinet (refer to Figure 5-7).

b. Connect Model 461A to a Variable Transformer. Set line voltage to 115 volts.

c. Connect common lead of DC Voltmeter (-hp- Model 412A) to -hp- Model 461A chassis ground and

VOLTS probe to terminal #6 of Transformer T1 (red wire). Refer to Figure 5-11.

d. The DC Voltmeter should indicate $+15 \pm 2$ volts.

e. Vary input line voltage with variable transformer from 103 to 127 volts. DC Voltmeter reading should not change by more than 0.5 volts from the reading observed in step d.

f. Connect VOLTS probe of DC Voltmeter to emitter of Q1 (yellow wire).

g. DC Voltmeter should indicate -15 volts ± 2 volts.

h. Vary input line voltage with variable transformer from 103 to 127 volts. DC Voltmeter reading should not change by more than 0.5 volts from the reading observed in step g.

i. Measure the ac voltage (-hp- Model 400L) between emitter of Q1 and ground; ripple voltage must be less than 1 mv for rated line voltage.

j. Measure the ac voltage between terminal #6 of Transformer T1 and ground; ripple voltage must be less than 1 mv for any rated line voltage.

5-23. GAIN CALIBRATION (461A and 462A).

a. Connect the 461A as shown in Figure 5-1.

b. Set the oscillator frequency to 500 KHz with its amplitude at minimum.

c. Set the attenuator to 50 db and connect the voltmeter to position A.

d. Adjust the oscillator amplitude for a voltmeter indication of -50 db.

e. Set the 461A GAIN (DB) control to 40 db and connect the voltmeter to position B. The voltmeter should read -10 db ± 0.5 db. If not, change the value of A3R18 until the voltmeter does indicate -10 db ± 0.5 db. The value of A3R18 is typically 4.7Ω to 10Ω .

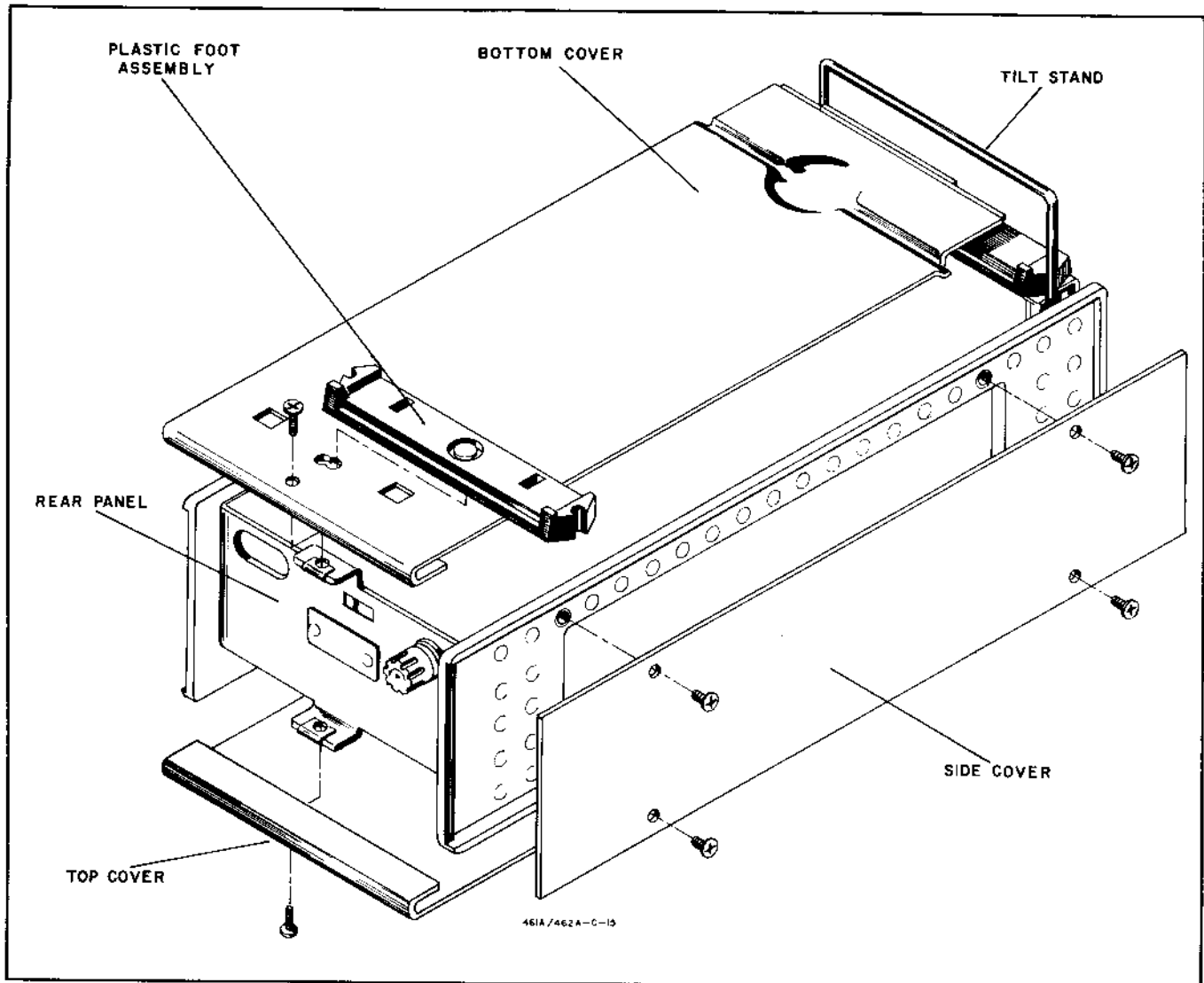

Figure 5-7. Panel Removal and Replacement

5-24. FREQUENCY RESPONSE CALIBRATION (461A).

a. This calibration procedure can also be used for a performance check procedure. The Telonic Model SM-2000 provides a linear sweep from 1 KHz to 200 MHz. The first External Monitor feeds a dc back to the sweep generator to stabilize the sweep output. It also feeds a reference level to the oscilloscope. The second External Monitor generates a dc output proportional to the RF output of the 461A. The sweep drive from the sweep generator is used as a horizontal input to the scope.

b. Connect the Model 461A as shown in Figure 5-8. Keep the lead length as short as possible.

c. Set the sweep generator for a 0-200 MHz sweep with 50 MHz markers:

SWEEP	100 Mc
MARKER	50 Mc
RF ATTENUATORS	0 db
RF FUNCTION	SWEEP
MONITOR	EXT

d. Set the oscilloscope to operate on an external sweep, and adjust vertical sensitivity to 0.01 v/cm (dc coupled). Adjust the horizontal sensitivity so that the display covers the screen.

e. Rotate Model 461A GAIN control to 40 db.

f. Set Oscilloscope VERTICAL PRESENTATION to channel B; adjust SENSITIVITY VERNIER for 10 cm presentation.

g. Set Oscilloscope VERTICAL PRESENTATION to B-A; adjust VERTICAL POSITION B to center trace.

h. Frequency response should vary less than ± 1 db from base line over frequency range of 10 to 150 MHz. 1 db $\approx 10\%$.

j. Adjust coils L2 thru L6 for optimum flatness from 1 KHz to 150MHz. (Refer to Figure 5-9.)

NOTE

It may also be necessary to adjust the overall gain by changing the value of R18 and R29 to achieve optimum flatness with 40 db of gain.

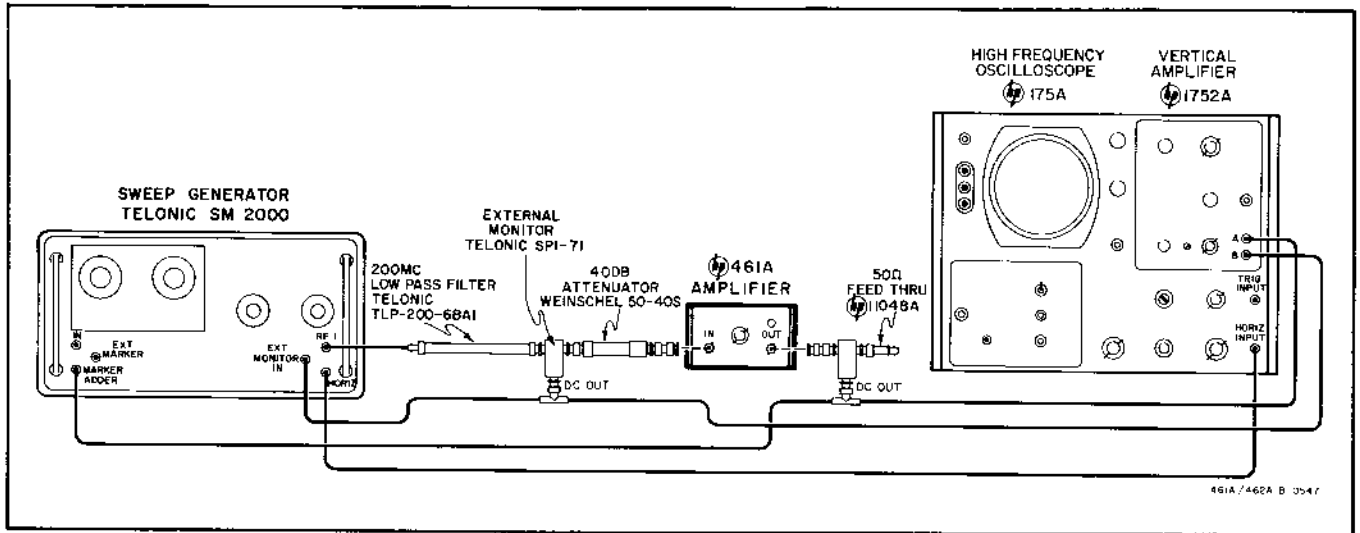

Figure 5-8. Frequency Response Calibration Setup

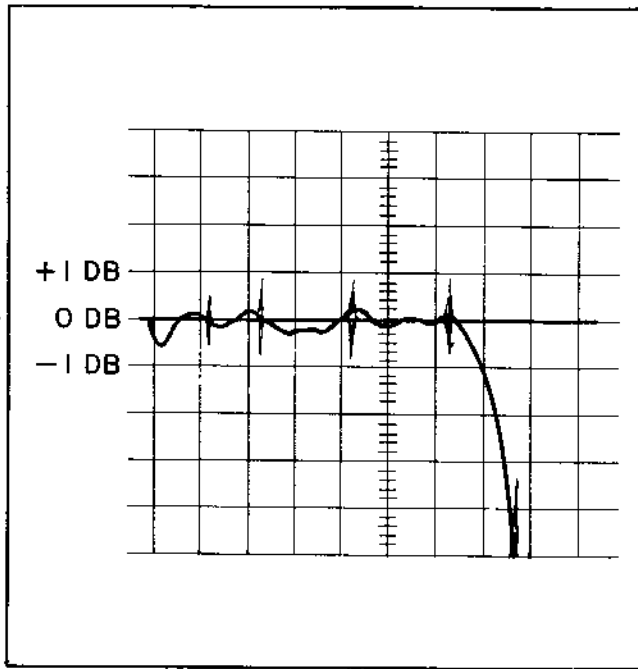

Figure 5-9. Frequency Response Calibration of -hp-461A, Markers at 25, 50, 100, 150 and 200 MHz

k. Recheck gain calibration at 500 KHz as outlined in Paragraph 5-20, steps a thru h.

5-25. PULSE RESPONSE CALIBRATION (462A).

- a. Connect the Model 462A as shown in Figure 5-5.
- b. Set attenuator to 50 db.
- c. Set 462A GAIN (DB) control to 40 db.
- d. Set up the pulse generator for a 30 nsec negative pulse at a repetition rate between 0.1 MHz and 1 MHz.
- e. Connect the oscilloscope and 50 Ω load to position B and set the oscilloscope to display one 30 nsec pulse. Observe the shape of the input pulse.

f. Adjust coils L2 thru L6 for optimum pulse response; rise and fall time <4 nsec; overshoot less than 5% (refer to Figures 5-10 and 5-11).

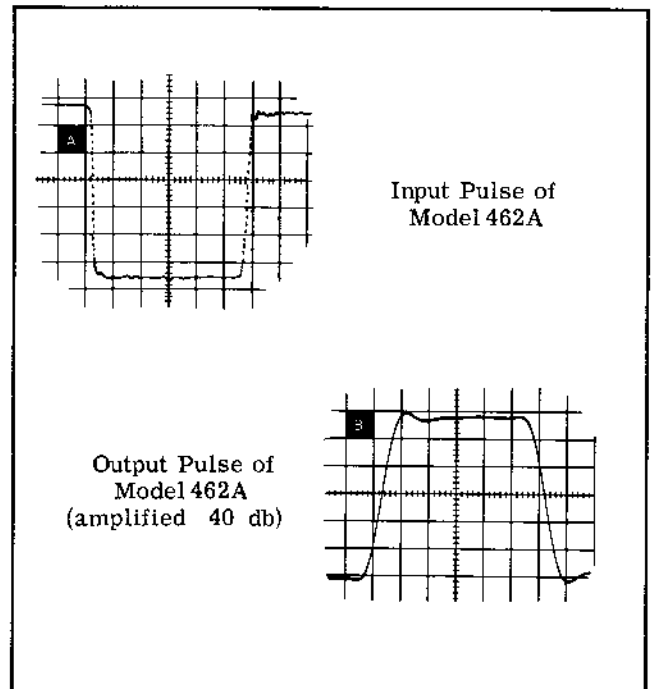

Figure 5-10. Input and Output Pulses of Model 462A as photographed on -hp- 185B Sampling Oscilloscope; Sweep Speed is 4 ns/cm

5-26. ETCHED CIRCUIT BOARDS.

5-27. The Model 461A uses both plated through and single sided etched circuit board types. Power supply assembly A2 uses the single sided etched-circuit board. The amplifier assembly A3 uses the plated-through type.

5-28. When replacing a component on the plated-through type of etched-circuit board, the component can be soldered from either side of the board. When replacing a component on the single sided board, the component should be soldered from the conductor side.

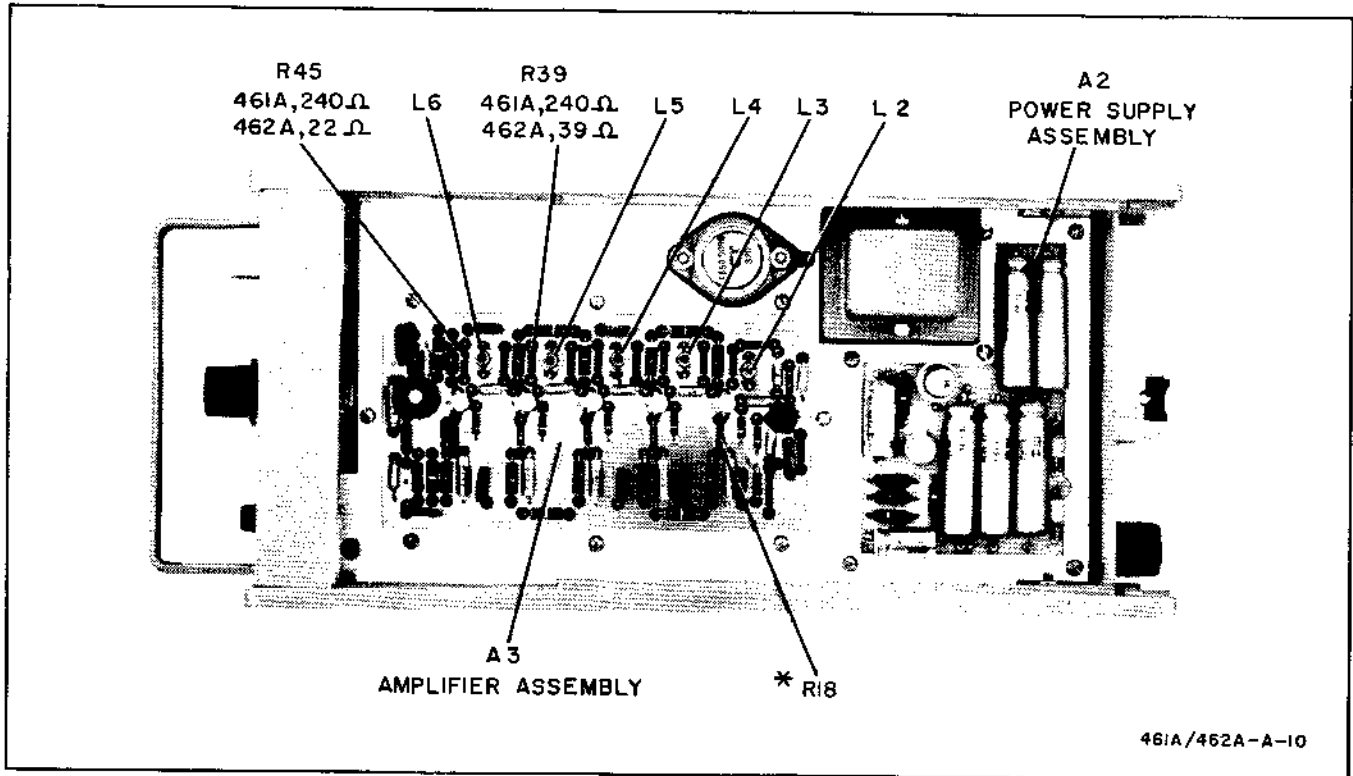

Figure 5-11. Top View

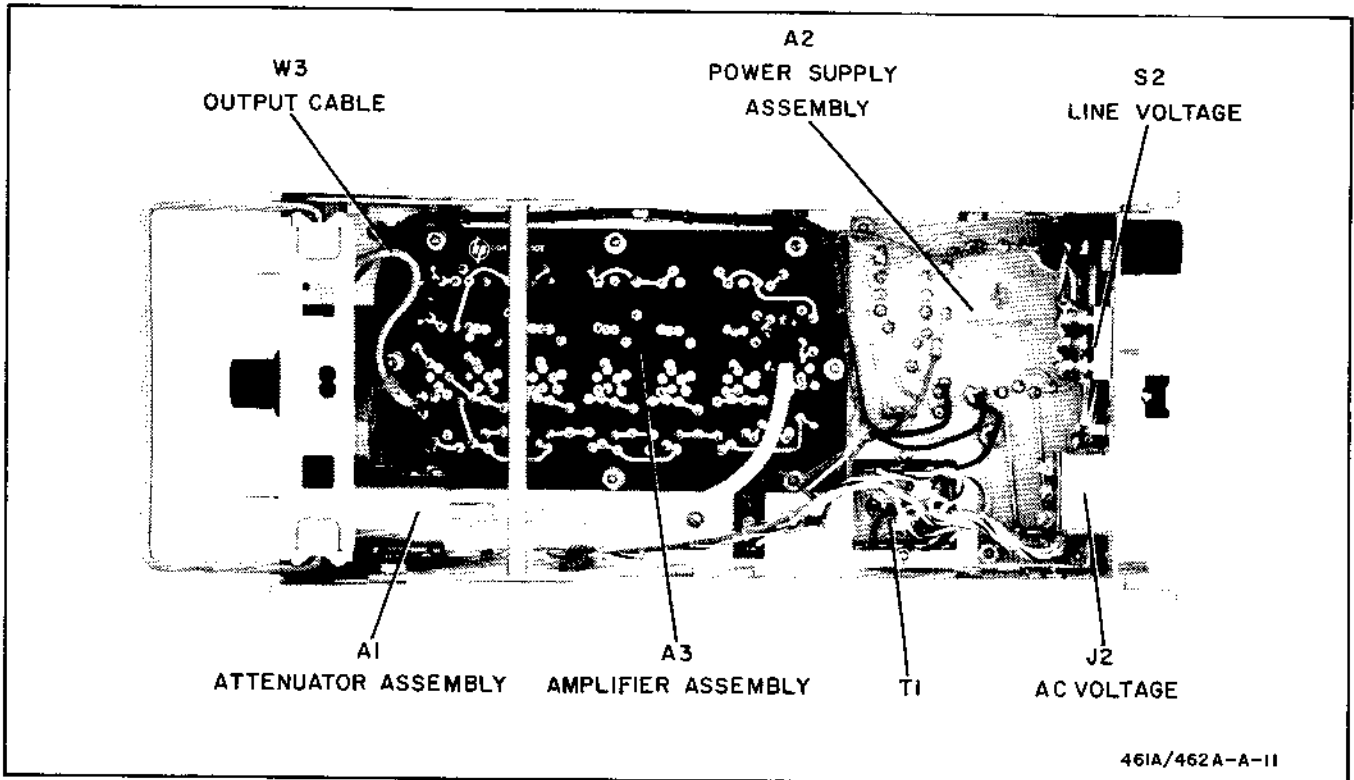

Figure 5-12. Bottom View

5-29. Regardless which type of etched-circuit board is used, the following rules should be followed:

- a. Avoid applying excessive heat when soldering on the circuit board. Use a 37 to 50 watt pencil tip soldering iron.
- b. To remove a damaged component, clip the component lead near the component. Then apply heat and remove the lead with a straight upward motion.
- c. Use a toothpick to free eyelet of solder before installing a new component.
- d. Solder from the conductor side of the board to insure good connections between the eyelet and the conductor.

5-30. TROUBLESHOOTING PROCEDURE.

- a. Start with a thorough visual inspection. Look for burned out or loose components, loose connections, or any other similar condition which suggests a source of trouble.
- b. Inspect the test setup being used when symptoms of malfunction were observed to be certain the source of trouble is not external to Amplifier.

- c. Check power supply as outlined in Paragraph 5-22.
- d. Check dc levels identified on the schematic diagram, Figure 5-13.
- e. Perform procedure outlined in Paragraph 5-23, steps a thru e.
- f. Using an AC Voltmeter (-hp- Model 400L), check the gain of transistors Q4 thru Q9, typically 8 db per stage.

NOTE

Gain of Q4 is controlled by the value of R18* (4.7 to 10 ohms).

- g. Rotate Model 461A GAIN control to 20 db to determine if malfunction is isolated to Attenuator; Amplitude of signal at base of Q3 should decrease by a factor of 10.
- h. The R-L feedback Network and transistors are responsible for the high frequency performance and should be checked if difficulty is encountered at high frequencies.
- i. Perform Calibration and Performance Check Procedures after repair is completed.

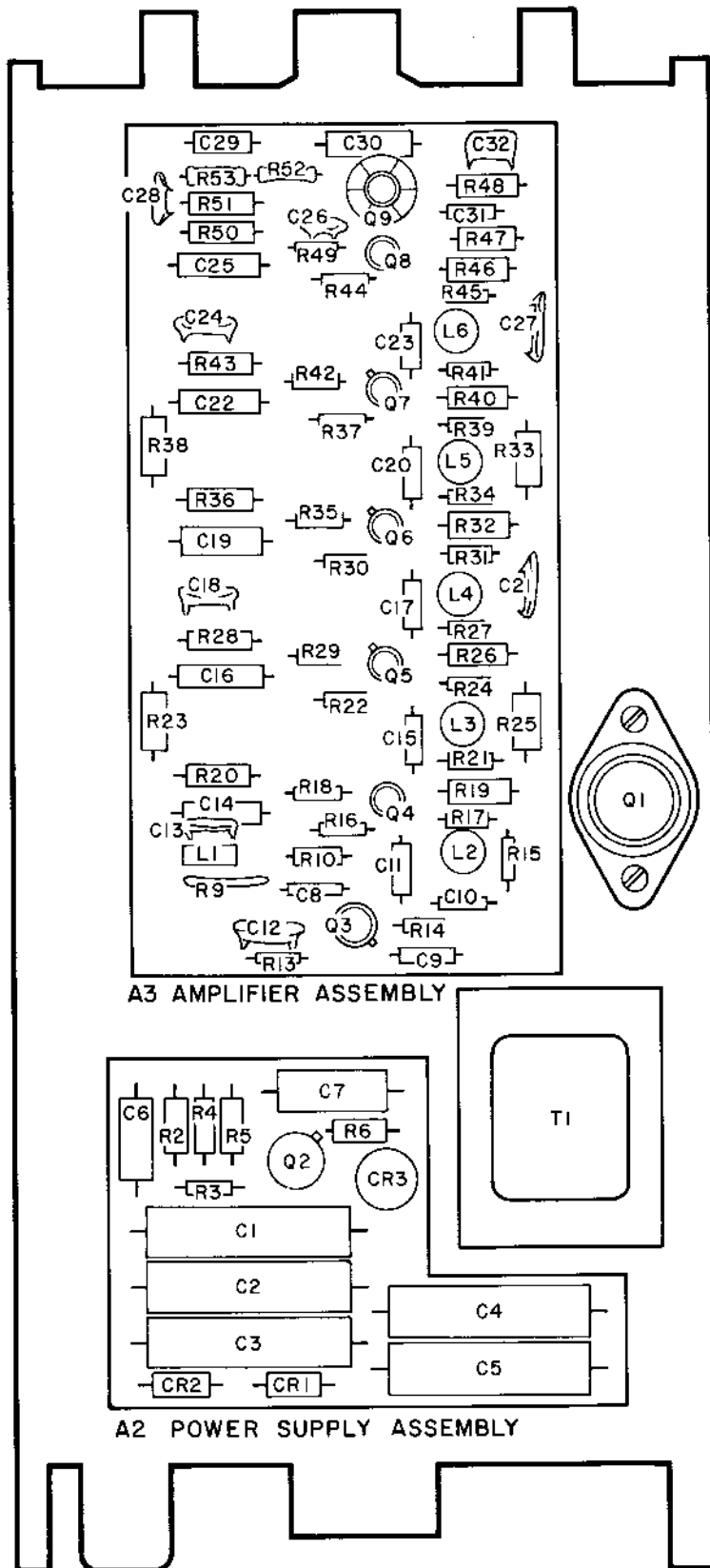

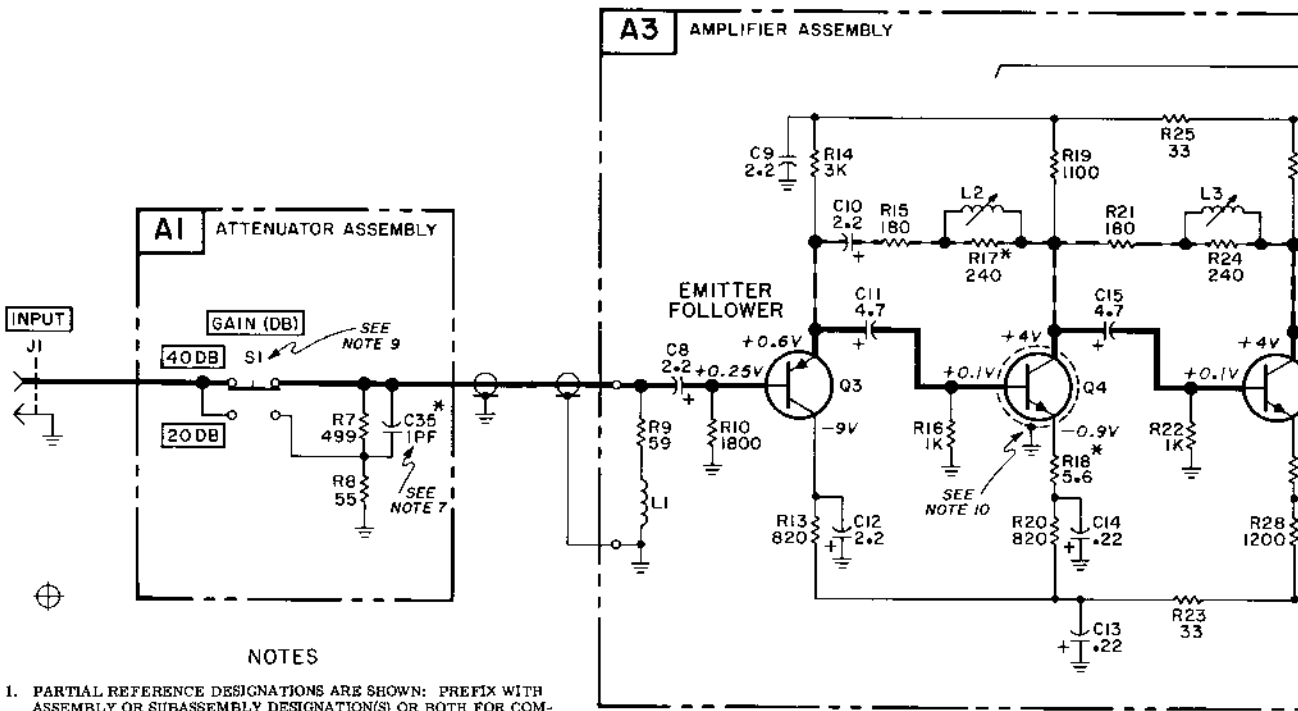

NOTES

1. PARTIAL REFERENCE DESIGNATIONS ARE SHOWN: PREFIX WITH ASSEMBLY OR SUBASSEMBLY DESIGNATION(S) OR BOTH FOR COMPLETE DESIGNATION.

2. COMPONENT VALUES ARE SHOWN AS FOLLOWS UNLESS OTHERWISE NOTED:

RESISTANCE IN OHMS
CAPACITANCE IN MICROFARADS

3. ——— DENOTES ASSEMBLY.

————— DENOTES MAIN SIGNAL PATH.

----- DENOTES FEEDBACK PATH.

4. DENOTES FRONT PANEL MARKING.

 DENOTES REAR PANEL MARKING.

5. DENOTES COMPONENTS NOT MOUNTED ON ASSEMBLY.

6. * AVERAGE VALUE SHOWN, OPTIMUM VALUE SELECTED AT FACTORY.

7. NOT INCLUDED IN MODEL 462A.

8. MAKE THE FOLLOWING VALUE CHANGES FOR MODEL 462A:

R17 TO 180 Ω	R39 TO 68 Ω
R24 TO 180 Ω	R45 TO 39 Ω
R29 TO 5.6 Ω	C11, 15, 17, 20, and 23 TO 2.2 μF
R31 TO 120 Ω	

9. S1 IS CAM ACTIVATED BY S3 IN THE 20 DB POSITION.

10. Q4 HAS A GROUNDED SHIELD. TERMINAL ARRANGEMENT IS AS SHOWN:



TOP VIEW

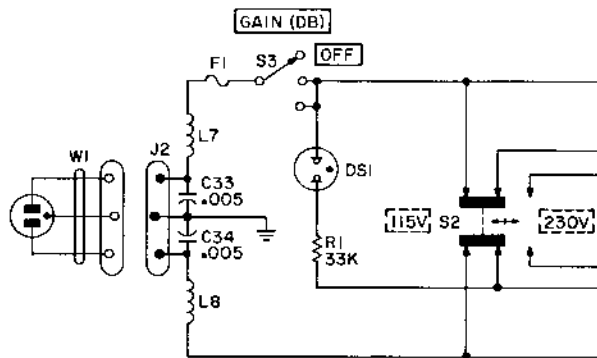

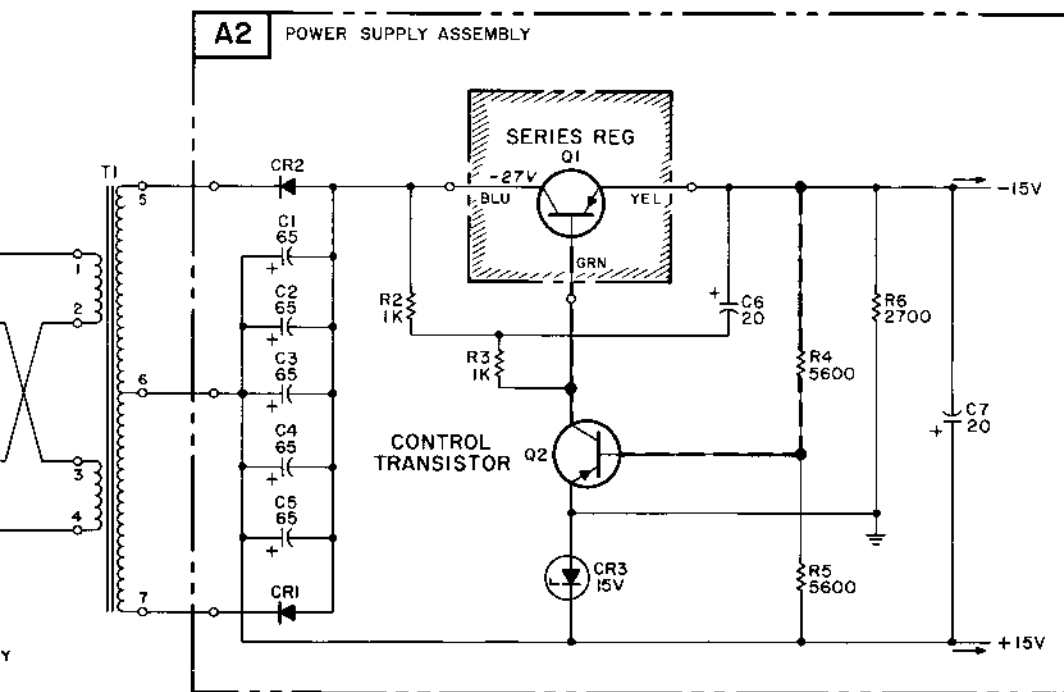
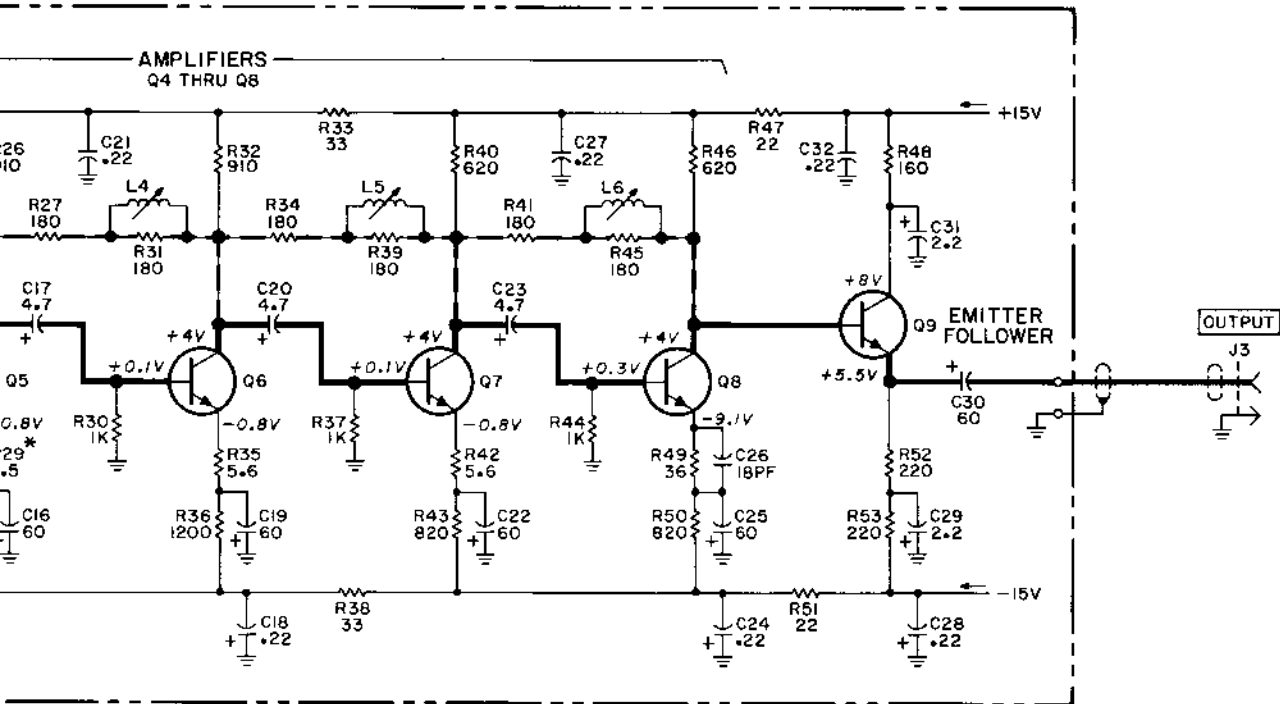

Figure 5-13. Schematic Diagram of Model 461A/462A

SECTION VI

REPLACEABLE PARTS

6-1. INTRODUCTION.

6-2. This section contains information for ordering replacement parts. Table 6-1 lists parts in alphabetic order of their reference designators and indicates the description and ϕ stock number of each part, together with any applicable notes. Table 6-2 lists parts in alphabetic order of their ϕ stock number and provides the following information on each part:

- a. Description of the part. (See list of abbreviations below.)
- b. Typical manufacturer of the part in a five-digit code. (See Appendix A for list of manufacturers.)
- c. Manufacturer's part number.
- d. Total quantity used in the instrument (TQ column).

6-3. Miscellaneous parts are listed at the end of Table 6-1.

6-4. ORDERING INFORMATION.

6-5. To obtain replacement parts, address order or inquiry to your local Hewlett-Packard Field Office. (See Appendix B for list of office locations.) Identify parts by their Hewlett-Packard stock numbers.

6-6. NON-LISTED PARTS.

6-7. To obtain a part that is not listed, include:

- a. Instrument model number.
- b. Instrument serial number.
- c. Description of the part.
- d. Function and location of the part.

DESIGNATORS

A	= assembly	F	= fuse	P	= plug	V	= vacuum tube, neon bulb, photocell etc.
B	= motor	FL	= filter	Q	= transistor	W	= cable
BT	= battery	HR	= heater	QCR	= transistor-diode	X	= socket
C	= capacitor	J	= jack	R	= resistor	XDS	= lampholder
CR	= diode	K	= relay	RT	= thermistor	XF	= fuseholder
DL	= delay line	L	= inductor	S	= switch	Z	= network
DS	= lamp	M	= meter	T	= transformer		
E	= misc electronic part	MP	= mechanical part	TC	= thermocouple		

ABBREVIATIONS

Ag	= silver	ID	= inside diameter	ns	= nanosecond (s) = 10^{-9}	SPDT	= single-pole double-throw
Al	= aluminum	imp	= impregnated	nsr	= not separately replaceable	SPST	= single-pole single-throw
amp	= ampere (s)	incd	= incandescent	obd	= order by description	Ta	= tantalum
Au	= gold	ins	= insulation (ed)	OD	= outside diameter	TiO ₂	= titanium dioxide
C	= capacitor	K	= kilohm (s) = 10^{+3}	p	= peak	log	= toggle
cer	= ceramic	Kc	= kilocycle (s) = 10^{+3}	pc	= printed circuit	tol	= tolerance
coef	= coefficient	L	= inductor	pf	= picofarad (s) = 10^{-12}	trim	= trimmer
com	= common	lin	= linear taper	piv	= peak inverse voltage	TSTR	= transistor
comp	= composition	log	= logarithmic taper	p/o	= part of	v	= volt (s)
conn	= connection	m	= milli = 10^{-3}	pos	= position (s)	vacw	= alternating current working volt (s)
cps	= cycles per second	ma	= milliamper (s) = 10^{-3}	poly	= polystyrene	var	= variable
dcp	= deposited	Mc	= megacycle (s) = 10^{+6}	pot	= potentiometer	vw	= direct current working volt (s)
DPDT	= double-pole double-throw	meg	= megohm (s) = 10^{+6}	p-p	= peak-to-peak	w	= watt (s)
DPST	= double-pole single-throw	met film	= metal film	prec	= precision (temperature coefficient, long term stability, and/or tolerance)	w/	= with
elect	= electrolytic	mfr	= manufacturer	R	= resistor	wiv	= reverse working voltage
encap	= encapsulated	mtg	= mounting	Rh	= rhodium	w/o	= without
f	= farad (s)	μ	= micro = 10^{-6}	rms	= root-mean-square	ww	= wirewound
FET	= field effect transistor	my	= Mylar $\text{\textcircled{R}}$	rot	= rotary	*	= optimum value selected at factory, average value shown (part may be omitted)
fxd	= fixed	na	= nanoampere (s) = 10^{-9}	Sc	= selenium	**	= no standard type number assigned (selected or special type)
GaAs	= gallium arsenide	NC	= normally closed	sect	= section (s)		
Gc	= gigacycle (s) = 10^{+9}	Ne	= neon	Sl	= silicon		
gd	= guard (ed)	NO	= normally open	sl	= slide		
Ge	= germanium	NPO	= negative positive zero (zero temperature coefficient)				
grd	= ground (ed)						
h	= henry (ies)						
Hg	= mercury						

$\text{\textcircled{R}}$ Dupont de Nemours

REV D

Table 6-1. Index by Reference Designator

Circuit Reference	-hp- Part No.	Description	Note
A1	00461-63401	Attenuator Assembly (461A only)	
A1	00462-63401	Attenuator Assembly (462A only)	

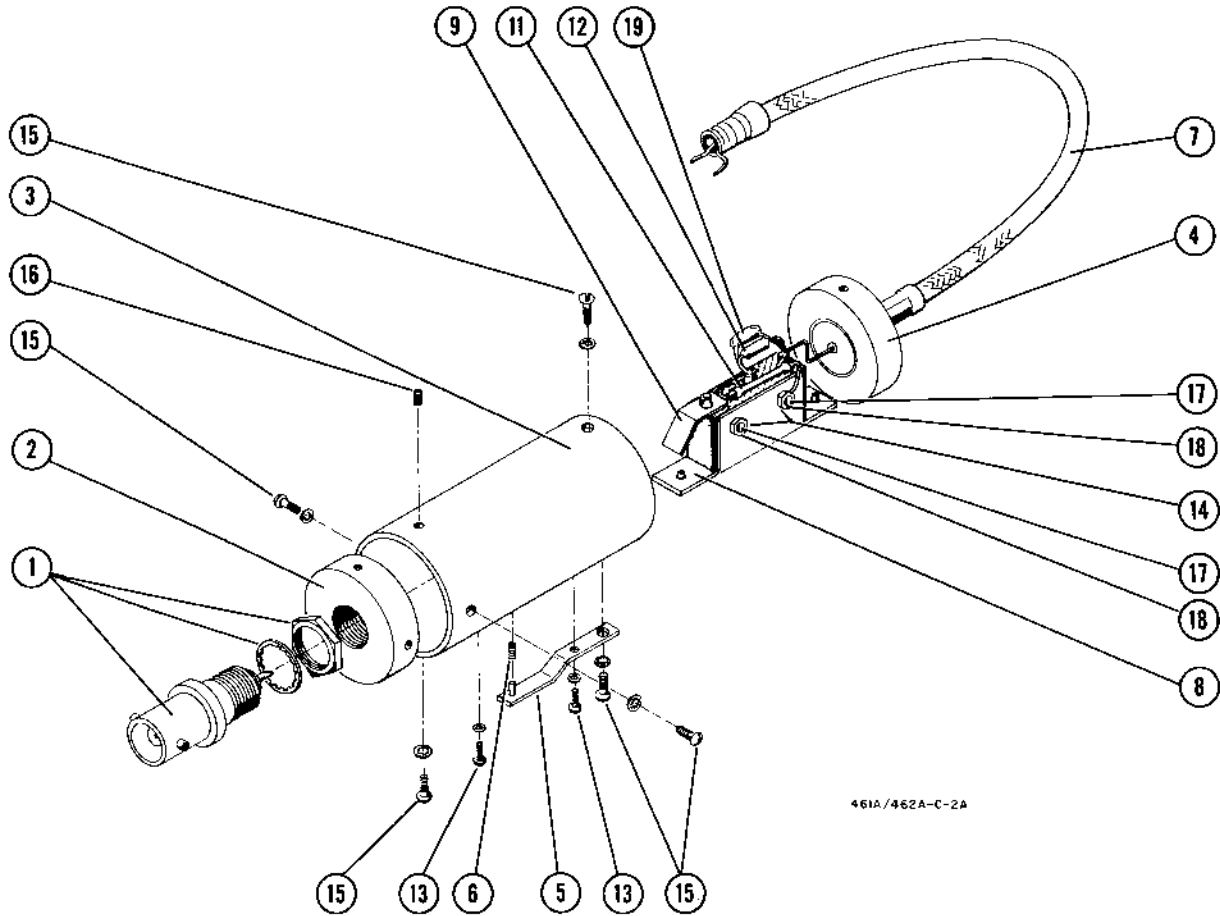

Exploded View of A1 Attenuator

No. on Illustration	Name/Designator	Part Number
1	Input Connector	1250-0047*
2	Can Front	00461-23402
3	Can Body	00461-23401
4	Can Rear	00461-23403
5	Spring Assembly	00461-69101
6	Compression Spring	1460-0159
7	Cable	00461-61604
8	Switch Bracket	00461-01202
9	Contact Spring	00461-09102
10	Switch S3	3102-0006
11	R7	0724-0060
12	R8	0757-0356
13	2-56 x 3/16 round head screw	0520-0005
14	No. 2 internal lock washer	2190-0014
15	4-40 round head screw and washer	2200-0004
16	4-40 x 3/16 socket head set screw	3030-0007
17	2-56 x 3/8 round head screw	0520-0022
18	2-56 nut	0610-0002
19	C35 (461A only)	0150-0029

*Although rubber ring is included in assembly, it is not used in this instrument.

Table 6-1. Reference Designation Index

REFERENCE DESIGNATION	-hp- PART NO.	DESCRIPTION	NOTE
A2	00461-66501	Etched Board, power	
A3	00461-66502	Etched Board, amplifier (461A only)	
A3	00462-66502	Etched Board, amplifier (462A only)	
C1 thru C5	0180-0149	C: fxd, elect, 65 μ f, 60 vdcw	
C6	0180-0045	C: elect, 20 μ f, 25 vdcw	
C7	0180-0049	C: elect, 20 μ f, 50 vdcw	
C8 thru C10	0180-0155	C: 2.2 μ f, 20 volts	
C11	0180-0309	C: 4.7 μ f, 10 volts (461A only)	
C12 and C13	0160-0170	C: 0.22 μ f, +80% -20%, 25 vdcw	
C14	0180-0106	C: fxd, elect \pm 20%, 60 μ f, 6 volts	
C15	0180-0309	Same as C11	
C16	0180-0106	Same as C14	
C17	0180-0309	Same as C11	
C18	0160-0170	Same as C12	
C19	0180-0106	Same as C14	
C20	0180-0309	Same as C11	
C21	0160-0170	Same as C12	
C22	0180-0106	Same as C14	
C23	0180-0309	Same as C11	
C24	0160-0170	Same as C12	
C25	0180-0106	Same as C14	
C26	0160-0356	C: 18 pf, \pm 5%, 250 volts	
C27, C28	0160-0170	Same as C12	
C29	0180-0155	Same as C8	
C30	0180-0106	Same as C14	
C31	0180-0155	Same as C8	
C32	0160-0170	Same as C12	
C33, C34	0150-0119	C: fxd, dual, 0.01 μ f, \pm 20%, 250 vacw	
C35	0150-0029	C: fxd, 1 pf, \pm 10%, 500 volts	
CR1, CR2	1901-0026	Diode, silicon, piv, 400 v	
CR3	1902-0239	Diode, reference, 14.7 v \pm 5%	
DS1	1450-0048	Pilot light, neon	
F1	2110-0004	Fuse - 1/4 amp, 115 v (fast-blo)	
J1	1250-0118	Connector, input - female	
J2	1251-0148	Connector, power, 3 pin - male	
J3	1250-0083	Connector, output - female	
L1	00461-86001	Coil, compensating	
L2	00461-86002	Coil, variable, 1.2 μ h	
L3	00461-86003	Coil, variable, 0.4 μ h	
L4	00461-86004	Coil, variable, 0.2 μ h	
L5	00461-86005	Coil, variable, 0.2 μ h	
L6	00461-86006	Coil, variable, 0.1 μ h	
L7 and L8	9170-0016	Ferrite Beads, (16 each)	

Table 6-1. Reference Designation Index (Cont'd)

REFERENCE DESIGNATION	-hp- PART NO.	DESCRIPTION	NOTE
Q1	1850-0098 1200-0043 1200-0081	Transistor, germanium, pnp Insulator for Q1 Bushing for Q1	
Q2	1850-0062	Transistor, germanium, selected, pnp	
Q3	1850-0106	Transistor, 2N1143	
Q4	1854-0073	Transistor, npn 2N2478 (462 only)	
Q5 thru Q7	1854-0220	Transistor, npn 2N3959	
Q8	1854-0219	Transistor, npn 2N3663	
Q9	1854-0019 1250-0018	Transistor, silicon, npn Heat dissipator for Q9	
R1	0687-3331	R: fxd, comp, 33K $\pm 10\%$, 1/2 W	
R2, R3	0687-1021	R: fxd, 1K $\pm 10\%$, 1/2 W	
R4, R5	0686-5625	R: fxd, 5.6K $\pm 5\%$, 1/2 W	
R6	0687-2721	R: fxd, 2.7K $\pm 10\%$, 1/2 W	
R7	0757-0356	R: 499 ohms $\pm 1\%$, 1/8 W	
R8	0724-0060	R: 55 ohms $\pm 1\%$, 1/4 W	
R9	0724-0061	R: 59 ohms $\pm 1\%$, 1/4 W	
R10	0684-1821	R: fxd, 1.8K $\pm 10\%$, 1/4 W	
R11, R12		Not Assigned	
R13	0686-8215	R: fxd, 820 ohms $\pm 5\%$, 1/4 W	
R14	0683-3025	R: fxd, 3K $\pm 5\%$, 1/4 W	
R15	0683-1815	R: fxd, 180 ohms $\pm 5\%$, 1/4 W	
R16	0684-1021	R: fxd, comp, 1K $\pm 10\%$, 1/4 W	
R17*	0683-2415	R: fxd, comp 240 ohms $\pm 5\%$, 1/4 W (461A only)	
R17	0683-1815	Same as R15 (462A only)	
R18*	0683-0565	R: fxd, 5.6 ohms $\pm 5\%$, 1/4 W	
R19	0686-1125	R: fxd, comp, 1.1K $\pm 5\%$, 1/2 W	
R20	0686-1525	R: 1.5K $\pm 5\%$, 1/2 W	
R21	0683-1815	Same as R15	
R22	0684-1021	Same as R16	
R23	0687-3301	R: fxd, comp, 33 ohms $\pm 10\%$, 1/2 W	
R24	0683-2415	R: fxd, comp, 240 ohms $\pm 5\%$, 1/4 W (461A only)	
R24	0683-1815	Same as R15 (462A only)	
R25	0687-3301	Same as R23	
R26	0686-9115	R: fxd, comp, 910 ohms $\pm 5\%$, 1/2 W	
R27	0683-1815	Same as R15	
R28	0686-1225	R: fxd, 1.2 K $\pm 5\%$, 1/2 W	
R29*	0683-0755	R: fxd, comp, 7.5 ohms $\pm 5\%$, 1/4 W (461A only)	
R29*	0683-0565	Same as R18 (462A only)	
R30	0684-1021	Same as R16	
R31	0683-1815	Same as R15 (461A only)	
R31	0683-1215	R: fxd, comp, 120 ohms $\pm 5\%$, 1/4 W (462A only)	
R32	0686-9115	Same as R26	
R33	0687-3301	Same as R23	
R34	0683-1815	Same as R15	
R35	0683-0565	Same as R18	
R36	0686-1225	Same as R28	
R37	0684-1021	Same as R16	
R38	0687-3301	Same as R23	
R39	0683-1815	Same as R15 (461A only)	
R39	0683-6805	R: fxd, 68 ohms $\pm 5\%$, 1/4 W (462A only)	

Table 6-1. Reference Designation Index (Cont'd)

REFERENCE DESIGNATION	-hp- PART NO.	DESCRIPTION	NOTE
R40	0686-6215	R: fxd, 620 ohms $\pm 5\%$, 1/2 W	
R41	0683-1815	Same as R15	
R42	0683-0565	Same as R18	
R43	0686-8215	Same as R13	
R44	0684-1021	Same as R16	
R45	0683-3905	R: fxd, comp, 39 ohms $\pm 5\%$, 1/4 W (462A only)	
R45	0683-1815	Same as R15 (461A only)	
R46	0686-6215	Same as R40	
R47	0687-2201	R: fxd, comp, 22 ohms $\pm 10\%$, 1/2 W	
R48	0686-1615	R: 160 ohms $\pm 5\%$, 1/2 W	
R49	0683-3605	R: fxd, comp, 36 ohms $\pm 5\%$, 1/4 W	
R50	0686-8215	Same as R13	
R51	0687-2201	Same as R47	
R52, R53	0758-0015	R: fxd, 220 ohms $\pm 5\%$, 1/2 W	
S1	3100-0759	Switch - rotary	
	0370-0104	Knob for S1	
S2	3101-0033	Switch - slide, dpdt	
S3	3102-0006	Switch - micro, spdt	
T1	9100-0277	Transformer	
W1	8120-0078	Cable, power	
W2	00461-61601	Cable, Ass'y	
W3	00461-61602	Cable, Ass'y output	
XF1	1400-0084	Fuseholder, extractor, post type	
		<u>MISCELLANEOUS</u>	
	1400-0116	Clamp, Cable plastic	
	1490-0031	Stand, Tilt	
	2370-0020	Screw, side plate, mounting, 6-32 Phillips head 3/16	
	5000-0700	Side panels	
	5000-0711	Cover, Bottom, 5 x 11 SM	
	5020-0700	Spacer	
	5040-0700	Hinge	
	5060-0700	Frame, Ass'y	
	5060-0709	Top Cover	
	5060-0727	Foot Ass'y: 1-3 mod.	
	00461-90002	Manual	

Table 6-2. Replaceable Parts

-hp- PART NO.	DESCRIPTION	MFR	MFR PART NO.	TQ
0150-0029	C: fxd, 1 pf, $\pm 10\%$, 500 volts	78488	GA1J0PF	1
0150-0119	C: fxd, dual, 0.01 μ f $\pm 20\%$, 250 vacw	56289	36C219A	1
0160-0170	C: 0.22 μ f, 25 vdcw $+80\%$ -20%	56289	5C9A	8
0160-0356	C: 18 pf $\pm 5\%$, 250 v	14655	CD-15C180J	1
0180-0045	C: elect, 20 μ f, 0.25 vdcw	56289	Type 30D	1
0180-0049	C: elect, 20 μ f, 50 vdcw	56289	30D198A1	1
0180-0106	C: fxd, elect $\pm 2\%$, 60 μ f, 6 v	56289	150D606-0006 B2	6
0180-0149	C: fxd, elect, 65 μ f, 60 vdcw	56289	Type 30D	1
0180-0155	C: fxd, 2.2 μ f, 20 volts	56289	150D225X002 0A2	5
0180-0309	C: fxd, 4.7 μ f, 10 volts (461A only)	56289	150D475X00 10A2	5
0520-0005	2-56 x 3/16 round head screw	73734	obd	2
0610-0002	2-56 Nut	28480	0610-0002	2
0683-0565	R: fxd, 5.6 ohms $\pm 5\%$, 1/4 W	01121	CB56G5	4
0683-0755	R: fxd, comp, 7.5 ohms $\pm 5\%$, 1/4 W (461A only)	01121	CB3315	1
0683-1215	R: fxd, comp, 1200 ohms $\pm 5\%$ 1/4 W (462A only)	01121	CB1215	1
0683-1815	R: fxd, comp, 180 ohms $\pm 5\%$, 1/4 W (462A only)	01121	CB1815	9
0683-2415	R: fxd, 240 ohms $\pm 5\%$, 1/4 W (461A only)	01121	CB2415	2
0683-3025	R: fxd, 3K $\pm 5\%$, 1/4 W	01121	CB3025	1
0683-3605	R: fxd, comp, 36 ohms $\pm 5\%$ 1/4 W	01121	CB3605	1
0683-6805	R: fxd, comp, 68 ohms $\pm 5\%$, 1/4 W (462A only)	01121	CB6805	2
0684-1021	R: fxd, comp, 1K ohm $\pm 10\%$, 1/4 W	01121	CB1021	6
0684-1821	R: fxd, 1.8K $\pm 10\%$, 1/4 W	01121	CB1821	1
0686-1125	R: fxd, 1.1K $\pm 5\%$, 1/2 W	01121	EB1125	1
0686-1225	R: fxd, 1.2K $\pm 5\%$, 1/2 W	01121	EB1225	2
0686-1525	R: 1.5K ohms $\pm 5\%$, 1/2 W	01121	EB1525	1
0686-1615	R: 160 ohms $\pm 5\%$, 1/2 W	01121	EB1615	1
0686-3905	R: fxd, 620 ohms $\pm 5\%$, 1/2 W	01121	EB3905	1
0686-5625	R: fxd, 5.6K $\pm 5\%$, 1/2 W	01121	EB5625	2
0686-6215	R: fxd, comp, 620 ohms $\pm 5\%$, 1/2 W	01121	EB6215	2
0686-8215	R: fxd, comp, 820 ohms $\pm 5\%$, 1/2 W	01121	EB8215	3
0686-9115	R: fxd, 910 ohms $\pm 5\%$, 1/2 W	01121	EB9115	2
0687-1021	R: fxd, 1K $\pm 10\%$, 1/2 W	01121	EB5625	2
0687-2201	R: fxd, 22 ohms $\pm 10\%$, 1/2 W	01121	EB2201	2
0687-2721	R: fxd, 2.7K $\pm 10\%$, 1/2 W	01121	EB2721	1
0687-3301	R: fxd, comp, 33 ohms $\pm 10\%$, 1/2 W	01121	EB3301	2
0687-3331	R: fxd, comp, 33K $\pm 10\%$, 1/2 W	01121	EB3331	1
0724-0060	R: 55 ohms $\pm 1\%$, 1/4 W	19701	DC1/4A	1
0724-0061	R: 59 ohms $\pm 1\%$, 1/4 W	19701	DC1/4A	1
0757-0356	R: 499 ohms $\pm 1\%$, 1/8 W	07115	N55	2
0758-0015	R: fxd, 220 ohms $\pm 5\%$, 1/2 W	07115	C20	2
1200-0043	Insulator for Q1	26365	obd	1
1200-0081	Bushing for Q1	26365	974 Special	1
1250-0018	Heat dissipator for Q9	95712	046-35	1
1250-0047	Input connector	95712	12682-1	1
1250-0083	Connector, output - female	95712	30624-1	1
1250-0118	Connector, input - female	95712	30384-1	1
1251-0148	Connector, power, 3 pin - male	60427	H10611G 3L	1
1400-0084	Fuseholder, extractor, post type	08717	858-R	1

Table 6-2. Replaceable Parts

-hp- PART NO	DESCRIPTION	MFR	MFR PART NO.	TQ
1400-0116	Clamp, cable plastic	08717	obd	
1450-0048	Pilot Light, neon	08717	858-R	1
1460-0159	Compression Spring	28480	1460-0159	1
1490-0031	Stand, tilt	28480	1490-0031	1
1850-0062	Transistor-germanium, PNP, selected	28480	1850-0062	1
1850-0098	Transistor-germanium, PNP	28480	1850-0098	1
1850-0106	Transistor, 2N1143	28480	1850-0106	1
1854-0019	Transistor, npn silicon	07263	2N2369	1
1854-0073	Transistor, npn, 2N3478 (462A only)	86684	2N3478	1
1854-0219	Transistor, npn, 2N3663	24446	2N3663	1
1854-0220	Transistor, npn, 2N3959	04713	2N3959	3
1901-0016	Diode, silicon piv, 400 v	28480	1901-0016	2
1902-0239	Diode, reference, 14.7 v $\pm 5\%$	28480	1902-0239	1
2110-0004	Fuse - 1/4 amp, 115 v (fast-blo)	75915	AG-Cat-312-250	1
2190-0014	No. 2 internal lock washer	78189	1902-00-00-2480	1
2200-0004	4-40 round head screw and washer	83385	obd	4
2370-0020	Screw sideplate mounting, 6-32 Phillipshead 3/16	83385	obd	8
3030-0007	4-40 x 3/16 socket head set screw	70276	obd	1
3100-0759	Switch, rotary	76854	obd	1
3101-0033	Switch-slide, DPDT	42190	4633	1
3102-0006	Switch, SPDT, pin plunger	91929	22-M261	1
5000-0700	Side panels	28480	5000-0700	2
5000-0711	Cover, bottom, 8 x 11 sm	28480	5000-0711	1
5020-0700	Spacer	28480	5020-0700	
5040-0700	Hinge	28480	5040-0700	
5060-0700	Frame Ass'y	28480	5060-0700	1
5060-0709	Top cover	28480	5060-0709	1
5060-0727	Foot Ass'y: 1-3 mod	28480	5060-0727	
8120-0078	Cable, power	70903	KH4147	1
9100-0277	Transformer	28480	9100-0277	1
9170-0016	Ferrite beads (16 each)	28480	9170-0016	32
00461-01102	Contact Spring	28480	00461-01102	1
00461-06961	Spring Assembly	28480	00461-06961	1
00461-23401	Can body	28480	00461-23401	1
00461-23402	Can front	28480	00461-23402	1
00461-23403	Can rear	28480	00461-23403	1
00461-61202	Switch Bracket	28480	00461-61202	1
00461-61601	Cable Assembly	28480	00461-61601	1
00461-61602	Cable - Output Assembly	28480	00461-61602	1
00461-61603	Cable Assembly	28480	00461-61603	1
00461-61604	Cable	28480	00461-61604	1
00461-63401	A1, Attenuator Ass'y (461A only)	28480	00461-63401	1
00462-63401	A1, Attenuator Ass'y(462A only)	28480	00461-63401	1
00461-66501	Etched board, power	28480	00461-66501	1
00461-66502	Etched board, amplifier (461A only)	28480	00461-66502	1
00462-66502	Etched board, amplifier (462A only)	28480	00461-66502	1
00461-86001	Coil - Compensating	28480	00461-86001	1
00461-86002	Coil - variable, 1.2 μ h	28480	00461-86002	1
00461-86003	Coil - variable, 0.4 μ h	28480	00461-86003	1
00461-86004	Coil - variable, 0.2 μ h	28480	00461-86004	1
00461-86005	Coil - variable, 0.2 μ h	28480	00461-86005	1
00461-86006	Coil - variable, 0.1 μ h	28480	00461-86006	1
00461-90002	Manual	28480	00461-90002	1



MANUAL BACKDATING CHANGES

MODEL 461A/462A

WIDE BAND AMPLIFIER

Manual Serial Prefixed: 606- (461A)
 551- (462A)
 -hp- Part No. 00461-90002

This manual backdating sheet makes this manual applicable to earlier instruments. Instrument-component values that differ from those in the manual, yet are not listed in the backdating sheet, should be replaced using the part number given in the manual.

Instrument Serial Prefix	Make Manual Changes	Instrument Serial Prefix	Make Manual Changes
421 (462A)	2	346 (461A)	1, 3, 5
414 (462A)	2, 3		
347 (462A)	2, 3, 5		
418 (461A)	1		

CHANGE #1

Figure 5-13, Schematic Diagram, and Section VI, Replaceable Parts:
 Change Q4 through Q8 to Transistor, silicon, NPN; -hp- Part No. 1854-0031.
 Change R17 to R: fxd, 330 Ω ; -hp- Part No. 0683-3315; and remove asterisk.
 Change R24 and R31 to R: fxd, 330 Ω ; -hp- Part No. 0683-3315.
 Change R29 to R29*; R: fxd, 5.6 Ω ; -hp- Part No. 0683-0565.

CHANGE #2

Section VI, Replaceable Parts:
 Change Q4 through Q8 to Transistor, silicon, NPN; -hp- Part No. 1854-0031.

CHANGE #3

Figure 5-13, Schematic Diagram, and Section VI, Replaceable Parts:
 Change R17, R24, and R31 to R: 330 Ω \pm 5%; -hp- Part No. 0683-3315.
 Change R18 to R: 5.6 Ω \pm 5%; -hp- Part No. 0683-0565.
 Change R39 to R: 39 Ω \pm 5%; -hp- Part No. 0683-3905.
 Change R45 to R: 22 Ω \pm 5%; -hp- Part No. 0683-2205.

CHANGE #4

Figure 5-13, Schematic Diagram, and Section VI, Replaceable Parts:
 Change R39, R45 to R: 240 Ω \pm 5%; -hp- Part No. 0683-2415.
 Change R31 to R: 330 Ω \pm 5%; -hp- Part No. 0683-3315.
 Delete C35*.

CHANGE #5

Figure 5-13, Schematic Diagram, and Section VI, Replaceable Parts:
 Change C11, C15, C17, C20, and C23 to C: 2.2 μ f, 20 v; -hp- Part No. 0180-0155.

 **MANUAL CHANGES**
MODEL 461A/462A

WIDEBAND AMPLIFIER

Manual Serial Prefixed: 606-(461A), 551-(462A)

-hp- Part No. 00461-90002

► New or revised item

Instrument Serial Number	Make Manual Changes	Instrument Serial Number	Make Manual Changes
ALL	ERRATA		

ERRATA:

Page 1-1, Specifications:

1. Change Model 461A Output to read:
0.5 volts rms. . .

Page 5-1, Paragraph 5-8:

1. Change step c to read:
Set coaxial attenuator to 60 dB.
2. Change step e to read:
Adjust the oscillator AMPLITUDE control for a
-50 dB indication . . .

Page 5-3, Paragraph 5-13:

1. Change the note to read:

NOTE

Either Paragraph 5-13, steps a thru o (Figure 5-4), or Paragraph 5-24, steps a thru h (Figure 5-8). . .

Page 5-4, Paragraph 5-15:

1. Change paragraph reference in step a to 5-14.

Page 5-8, Figure 5-11:

1. Change values of R45 and R39 as follows:

R45	R39
461A, 180Ω	461A, 180Ω
462A, 39Ω	462A, 68Ω

Page 5-11/5-12, Schematic Diagram:

1. Change value of following components:
 - C33 to 0.01 μF
 - C34 to 0.01 μF
 - C12 to 0.22 μF
 - C14 to 60 μF
 - R20 to 1500 ohms

ERRATA (Cont'd)

Page 5-11/5-12, Schematic Diagram (Cont'd):

2. Add asterisk to capacitor C26.
3. Add following note:
For selection of R13* see Paragraph 5-23.
4. Change the following dc voltage levels:
Base of Q4 thru Q7 to -0.1 V
Base of Q8 to -0.3 V
Emitter of Q8 to -1 V
Emitter of Q9 to +3.3 V

Table 6-1 and 6-2, Replaceable Parts:

1. Page 6-2, exploded view, interchange Part No. of R7 and R8.
- ▶ 2. In description column of Q4 change 2N2478 to 2N3478. and delete - (462 only).
3. Change Q5 thru Q7 to -hp- Part No. 1854-0305, silicon NPN.
4. Add asterisk to C26 and C35.
5. Change -hp- Part No. of R13 to 0683-8215.
6. Page 6-7, change Part No. of contact spring to 00461-09102, and change Part No. of spring assembly to 00461-69101.