



HEWLETT-PACKARD COMPANY / OPERATING AND SERVICE MANUAL

411A

RF MILLIVOLTMETER

15mv

hp 411A

 OPERATING AND SERVICE MANUAL

MODEL 411A

SERIALS PREFIXED: 131 -

RF MILLIVOLTMETER

Copyright HEWLETT-PACKARD COMPANY 1962
1501 PAGE MILL ROAD, PALO ALTO, CALIFORNIA, U.S.A.

01193-1



Printed: FEB 1962

TABLE OF CONTENTS

Section	Page	Section	Page
I GENERAL INFORMATION	1-1	IV PRINCIPLES OF OPERATION (Cont'd)	
1-1. General Description	1-1	4-16. Cathode Follower	4-2
1-3. Probe Tips Available	1-1	4-20. Modulator and 100 kc Oscillator . .	4-2
1-6. Instrument Identification	1-1	4-22. Power Amplifier	4-2
1-8. Power Cable	1-1	4-25. Feedback	4-2
II PREPARATION FOR USE	2-1	V MAINTENANCE	5-1
2-1. Unpacking & Mechanical Inspection .	2-1	5-1. Introduction	5-1
2-4. Operation Check	2-1	5-6. Test Equipment	5-1
2-6. Installation	2-1	5-8. Removing the Cabinet	5-2
2-8. Power Requirements	2-1	5-10. Cartridge and/or Cable Replacement	5-2
2-10. Operation on 115 or 230 Volts . . .	2-1	5-13. Tube Replacement	5-2
2-13. Rack-Mount Model	2-1	5-16. Troubleshooting	5-2
2-15. Preparation for Storage and Shipment	2-1	5-19. Measure Power Supply Voltages .	5-2
2-18. Storage	2-1	5-21. Measure Ripple	5-3
III OPERATION	3-1	5-24. Downscale Meter Circuit	5-3
3-1. Preliminary Considerations	3-1	5-26. Modulator/Amplifier Tuning	5-3
3-5. Probe Tips	3-1	5-30. Modulator/Amplifier Gain	5-5
3-17. Selection of Probe Tip	3-2	5-31. Upscale Meter Circuit	5-5
3-19. Installation of Probe Tips	3-2	5-33. Output Circuit	5-5
3-22. Mechanical Meter-Zero	3-2	5-34. Bias Adjustment	5-5
3-24. Zero Adjustment	3-2	5-35. Hum Balance	5-5
3-27. Interpreting Reading	3-2	5-36. Zero Control	5-5
IV PRINCIPLES OF OPERATION	4-1	5-37. Chopper Amplifier Gain	5-5
4-1. Introduction	4-1	5-40. Maintenance Procedures	5-5
4-7. Probe	4-2	5-41. Transistor or Tube Replacement .	5-5
4-10. Modulator	4-2	5-43. Calibration	5-5
4-12. Chopper Amplifier	4-2	5-45. Final Test	5-7
4-14. Demodulator	4-2	VI REPLACEABLE PARTS	6-1
		6-1. Introduction	6-1
		6-4. Ordering Information	6-1

LIST OF ILLUSTRATIONS

Number	Title	Page	Number	Title	Page
1-1. Model 411A RF Millivoltmeter		1-1	3-8. Frequency Response of		
3-1. Frequency Response of BNC Open			Capacitive Divider		3-1
Circuit Probe Tip		3-0	3-9. Electrical Zero Adjustment		3-3
3-2. Input Impedance of BNC Open			3-10. Operating Procedure		3-4
Circuit Probe Tip		3-0	4-1. Block Diagram		4-1
3-3. Frequency Response of Type N			5-1. Servicing Etched Circuit Boards		5-4
"T" Probe Tip		3-0	5-2. Calibration Test Setup		5-6
3-4. Frequency Response of Pen-Type			5-3. Right Side Internal View		5-6
Probe Tip		3-0	5-4. Test Setup for Final Test		5-7
3-5. Input Impedance of Pen-Type Probe Tip .		3-0	5-5. Left Side Internal View		5-8
3-6. Frequency Response of VHF Probe Tip .		3-0	5-6. Power Supply (Schematic Diagram) . . .		5-10
3-7. Input Impedance of VHF Probe Tip . . .		3-1	5-7. Voltmeter (Schematic Diagram)		5-11

LIST OF TABLES

Number	Title	Page
1-1. Specifications		1-0
5-1. Recommended Test Equipment		5-1
5-2. Component Replacement		5-2
6-1. Reference Designation Index		6-2
6-2. Replaceable Parts		6-8

Table 1-1. Specifications

VOLTAGE RANGE:

10 mv rms full scale to 10 volts rms full scale in seven ranges. Full scale readings of 0.01, 0.03, 0.3, 1, 3, and 10 volts rms.

FREQUENCY RANGE:

500 kc to 1 gc with accessory probe tips.

ACCURACY:

500 kc to 50 mc, $\pm 3\%$ of full scale; 50 mc to 150 mc, $\pm 6\%$ of full scale; 150 mc to 1 gc, ± 1 db using appropriate probe tips.

METER SCALES:

Two linear voltage scales, 0 to 1 and 0 to 3, calibrated in the rms value of a sine wave. DB scale, calibrated from +3 to -12 db; 0 db= 1 mw in 50 ohms.

PROBE TIP FURNISHED:

411A- 21E BNC Open Circuit Probe Tip, 500 kc to 500 mc. Shunt capacity: Less than 4 pf. Maximum input: 200 vdc. Input resistance at 10 mc: typically 80K ohms.

INPUT RESISTANCE:

Depends on probe tip, frequency and input voltage typically 200K ohms at 1 mc and 1 volt rms.

ACCESSORIES AVAILABLE:

Probe Tips:

411A-21B Pen Type Probe Tip, 500 kc to 50 mc. Shunt capacity: Less than 4 pf. Maximum input: 200 vdc. Input resistance at 10 mc: typically 80K ohms.

411A-21C VHF Probe Tip, 500 kc to 250 mc. Shunt capacity: Less than 2-1/2 pf. Maximum input: 200 vdc. Input resistance at 10 mc: typically 80K ohms.

411A-31D Type N "Tee" Probe Tip, 1 mc to 1 gc. SWR is less than 1.15 when terminated in 50 ohms. Maximum input: 10 vdc.

411A-21F 100:1 Capacity Divider Probe Tip, 500 kc to 250 mc. Division Accuracy: $\pm 1\%$; shunt capacity: 2 pf. Maximum input: 1000 volts pk (dc + pk ac).

PROBE KIT:

411A-21G Accessory Probe Kit. This kit includes the 411A-21B, 411A-21C, 411A-21D, 411A-21F Probe Tips and a 411A-21A-3 Replacement Diode Cartridge.

TERMINATION:

Ⓜ Model 908A 50-ohm Termination, Type N male, swr less than 1.05 from dc to 4000 mc.

GALVANOMETER RECORDER OUTPUT:

Proportional to meter deflection. 1 ma into 1000 ohms at full scale deflection.

POWER:

115 or 230 volts $\pm 10\%$, 50 to 60 cps, 35 watts.

DIMENSIONS:

Cabinet Mount: 11-3/4 in. high, 7-1/2 in. wide, 12 in. deep

Rack Mount:

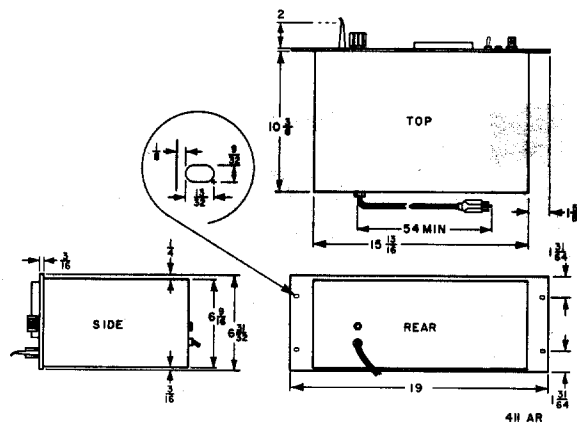

WEIGHT:

Cabinet Mount: Net 12 lb, shipping 18 lb

Rack Mount: Net 15 lb, shipping 28 lb

SECTION I

GENERAL INFORMATION

1-1. GENERAL DESCRIPTION.

1-2. The Hewlett-Packard Model 411A RF Millivoltmeter is a sensitive ac voltmeter which will measure accurately from 0.01 volt rms to 10 volts rms full scale in the frequency range of 500 kc to 1000 mc (1 gc). The 411A probe when used without accessories will respond to frequencies up to 4 gc and may be used as an indicator up to this frequency. The Model 411A is supplied with a BNC-type screw-on probe tip providing easy and rapid measurement at low frequencies. Other probe tips, which make possible convenient measurement at 1000 mc, are available. The Model 411A has a recorder output with an adjustable level.

CAUTION

See paragraph 3-3 for instructions before attempting to operate this instrument.

1-3. PROBE TIPS AVAILABLE.

1-4. To increase the usefulness of the Model 411A, a number of screw-on probe tips are available individually as follows:

Probe Tip	hp Stock No.	Frequency Range
Clip-on	411A-21B	500 kc - 50 mc
VHF	411A-21C	500 kc - 250 mc
Type N "T"	411A-21D	1 mc - 1000 mc
BNC (supplied)	411A-21E	500 kc - 500 mc
100:1 Divider	411A-21F	500 kc - 250 mc

1-5. A complete probe-tip kit containing these probe tips plus an extra, replacement, cartridge in a handy case is available from Hewlett-Packard as stock number 411A-21G.

1-6. INSTRUMENT IDENTIFICATION.

1-7. Hewlett-Packard uses a two-section eight-digit serial number (000-00000). If the first three digits of the serial number on your instrument do not agree with those on the title page of this manual, change sheets supplied with the manual will define differences between your instrument and the Model 411A described in this manual.

1-8. POWER CABLE.

1-9. For the protection of operating personnel, the National Electrical Manufacturer's Association (NEMA) recommends that the instrument panel and cabinet be grounded. All Hewlett-Packard instruments are equipped with a three-conductor power cable which, when plugged into an appropriate receptacle, grounds the instrument. The offset pin on the power cable three-prong connector is the ground pin.

1-10. To preserve the protection feature when operating the instrument from a two-contact outlet, use a three-prong to two-prong adapter and connect the green pigtail on the adapter to ground.

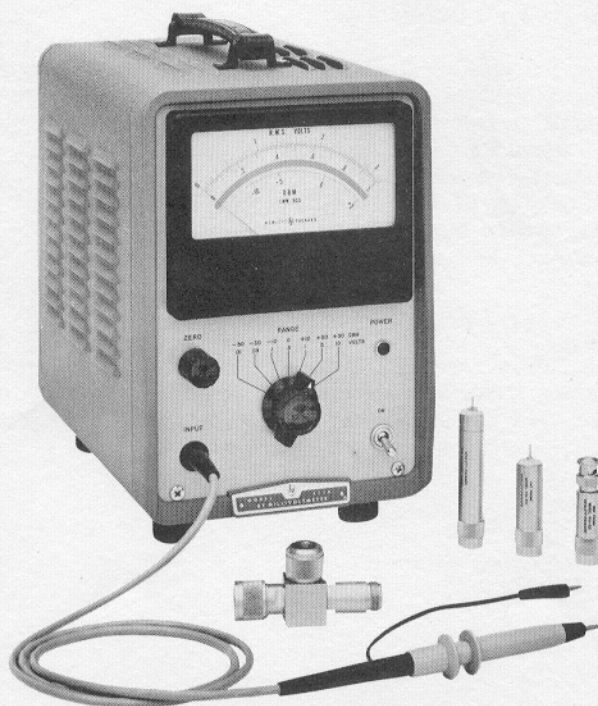

Figure 1-1. Model 411A RF Millivoltmeter

SECTION II

PREPARATION FOR USE

2-1. UNPACKING & MECHANICAL INSPECTION.

2-2. Inspect instrument for signs of damage incurred in shipment. This instrument should be tested as soon as it is received (see Final Test at the end of this manual). If it fails to operate properly, or is damaged in any way, a claim should be filed with the carrier. A full report of the damage should be obtained by the claim agent, and this report should be forwarded to us. We will then advise you of the disposition to be made of the equipment and arrange for repair or replacement. Include model number and serial number when referring to this instrument for any reason.

2-3. Hewlett-Packard Company warrants each instrument manufactured by them to be free from defects in material and workmanship. Our liability under this warranty is limited to servicing or adjusting any instrument returned to the factory for that purpose and replacing any defective parts thereof. File a claim with the carrier as instructed in warranty page.

2-4. OPERATION CHECK.

2-5. This instrument should be checked as soon as it is received to determine that its electrical characteristics have not been damaged in shipment. Refer to the Final Check at the end of this manual.

2-6. INSTALLATION.

2-7. This instrument depends upon air cooling. Therefore it is advisable to place the instrument on the table or work bench so that the air can circulate freely through the instrument.

2-8. POWER REQUIREMENTS.

2-9. Power requirements are given in table 1-1.

2-10. OPERATION ON 115 OR 230 VOLTS.

2-11. The Model 411A can be quickly and easily converted to operate from a nominal line voltage of 230 volts and a frequency of 50 to 60 cps. The instrument is normally supplied with the power transformer

dual primary windings connected in parallel for 115-volt operation. To convert for 230-volt operation remove cabinet as in paragraph 5-8 and reconnect the primary windings in series as shown on the schematic diagram. Replace the 1 ampere slow-blow fuse used on 115 volt input with a 1/2 ampere slow-blow fuse for 230-volt operation.

2-12. As an option the instrument may be wired to do the switching by means of a slide switch S102. To convert this type of instrument to 230 volts first turn the instrument off. Then with a pointed tool such as a pencil tip, flip the slide switch to the 230-volt position. Instrument may now be operated on 230 volts.

2-13. RACK-MOUNT MODEL.

2-14. This instrument is also available in a rack-mount version in addition to the cabinet model shown in figure 1-1. The rack-mount version is identical electrically and similar physically except that the controls have been rearranged on the rack-mount version.

2-15. PREPARATION FOR STORAGE AND SHIPMENT.

2-16. The best method of packing this instrument is in the original shipping carton with the original fillers packed in the same manner as when received from the factory. Therefore when unpacking, note carefully the method of packing and save the original packing material for possible future re-use.

2-17. If the original packing material is not available and it is desired to package the instrument for storage or shipment, first wrap the instrument in heavy kraft paper to avoid scratching the paint. Then pack in a cardboard carton with a bursting strength of at least 150 lb per square inch. Pad the instrument on all sides with at least 2 inches of rubberized hair or at least 4 inches of tightly packed excelsior.

2-18. STORAGE.

2-19. No special precautions are necessary in storage except the usual precautions against mechanical or water damage.

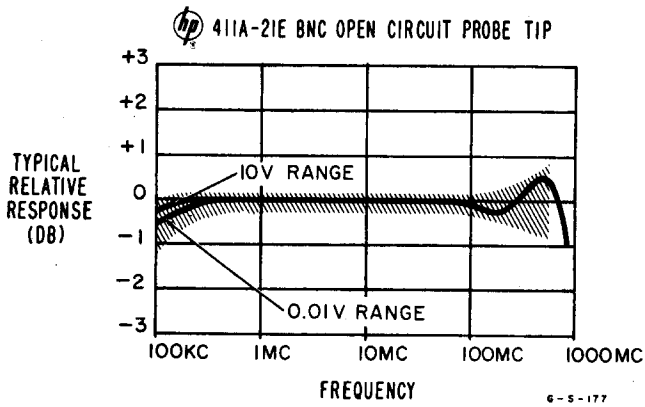

Figure 3-1. Frequency Response of BNC Open Circuit Probe Tip

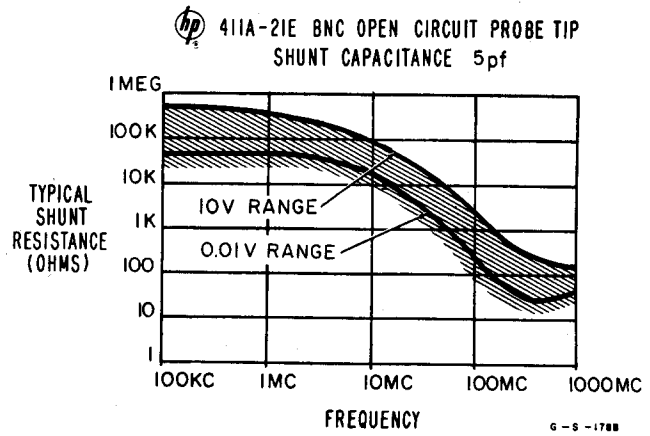

Figure 3-2. Input Impedance of BNC Open Circuit Probe Tip

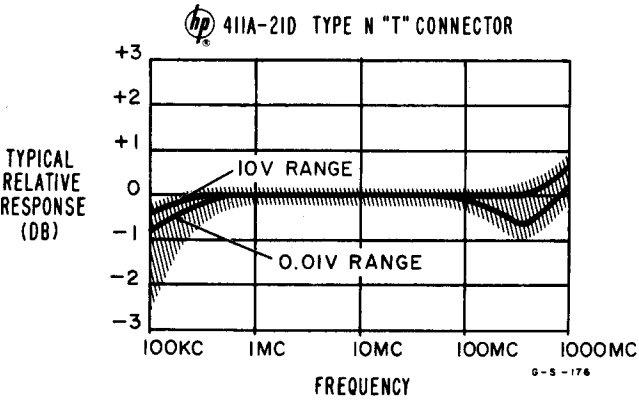

Figure 3-3. Frequency Response of Type N "T" Probe Tip

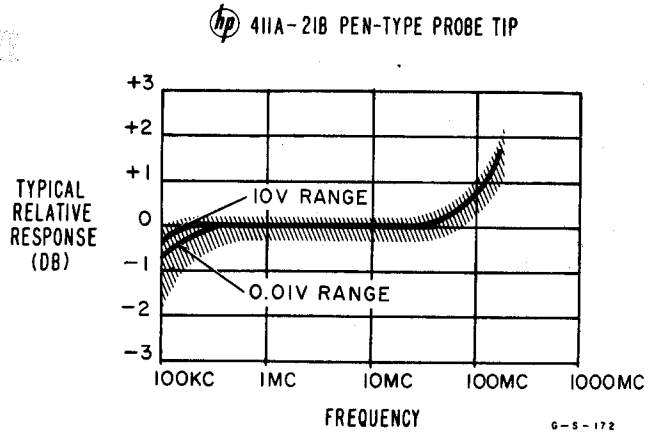

Figure 3-4. Frequency Response of Pen-Type Probe Tip

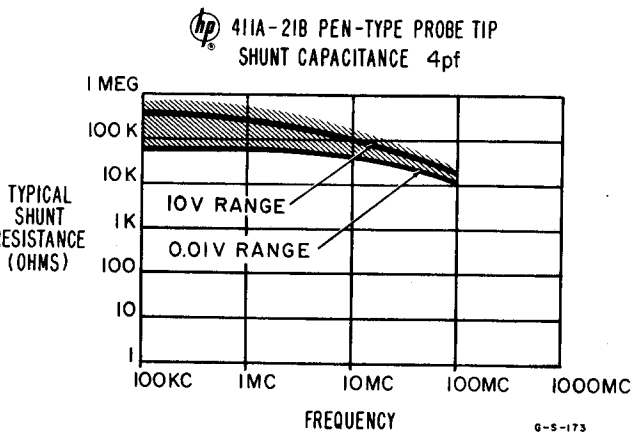

Figure 3-5. Input Impedance of Pen-Type Probe Tip

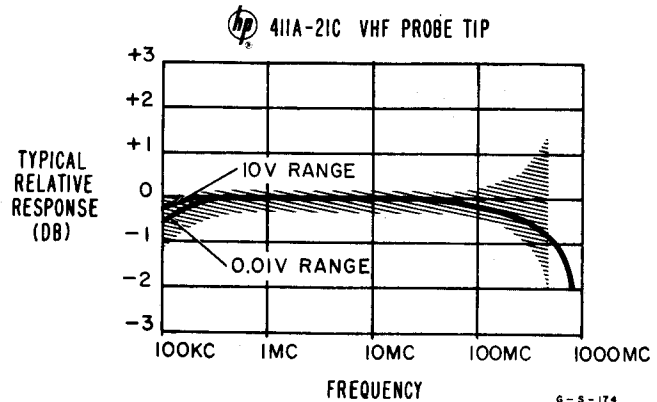

Figure 3-6. Frequency Response of VHF Probe Tip

SECTION III OPERATION

3-1. PRELIMINARY CONSIDERATIONS.

3-2. For the majority of your uses (measuring continuous sine waves) the hp Model 411A will indicate the root-mean-square value directly. When measuring unusual waveforms, a correction factor may be necessary. See paragraph 3-27, Interpreting the Reading, for further details.

CAUTION

BE SURE TO GROUND THIS INSTRUMENT
BEFORE USE.

3-3. Good rf measurements require proper grounding. The Model 411A contains a line filter to eliminate stray rf from the power line. Therefore, you must ground the instrument chassis properly to make significant measurements. In addition, the filter configuration is such that if you do not ground the instrument, its chassis assumes a voltage of about one-half the line voltage, and you can damage circuits under test.

3-4. To ground your instrument properly use a NEMA receptacle with a third-prong ground. If, however, you use the two-prong power adaptor be sure to ground the third wire pigtail.

3-5. PROBE TIPS.

3-6. Five probe tips are available for the Model 411A. These probe tips enable you to use the Model 411A for almost any measuring application. Data to guide you in the selection of the proper probe tip follows (shaded areas indicate possible variations due to temperature). If you wish to make your own probe tip the necessary data is also given. The following probe tips are available:

3-7. BNC OPEN CIRCUIT PROBE TIP. Hewlett-Packard stock number 411A-21E. Frequency range 500 kc to 500 mc. Maximum voltage 200 volts dc or 30 volts peak ac. Typical frequency response with voltage and frequency is as shown in figure 3-1.

3-8. Typical input resistance varies with voltage and frequency as shown in figure 3-2.

3-9. TYPE N "T" PROBE TIP. Hewlett-Packard stock number 411A-21D. Frequency range 1 mc to 1000 mc. SWR is less than 1.15 when terminated in 50 ohms. Maximum input 10 volts dc and 30 volts ac. Typical frequency response with voltage and frequency is as shown in figure 3-3.

3-10. SWR is less than 1.15 when terminated in 50 ohms. Insertion loss is less than 1 db (less than 0.1 db up to 150 mc).

3-11. PEN-TYPE PROBE TIP. Hewlett-Packard stock number 411A-21B. Frequency range 500 kc to 50 mc. Maximum input 200 volts dc and 30 volts peak ac. Typical frequency response with voltage and frequency is as shown in figure 3-4.

3-12. Typical input resistance varies with voltage and frequency as shown in figure 3-5.

3-13. VHF PROBE TIP. Hewlett-Packard stock number 411A-21C. Frequency range 500 kc to 250 mc. Maximum input 200 volts dc and 30 volts peak ac. Typical frequency response with voltage and frequency is as shown in figure 3-6.

3-14. Typical input resistance varies with voltage and frequency as shown in figure 3-7.

3-15. CAPACITIVE DIVIDER (100:1). Hewlett-Packard stock number 411A-21F. Frequency range 500 kc to

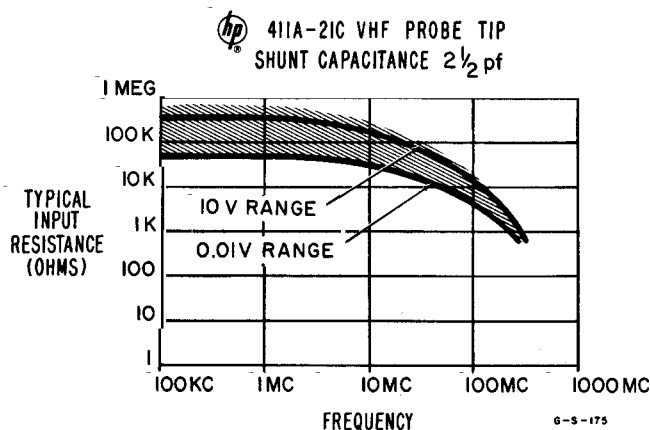

Figure 3-7. Input Impedance of VHF Probe Tip

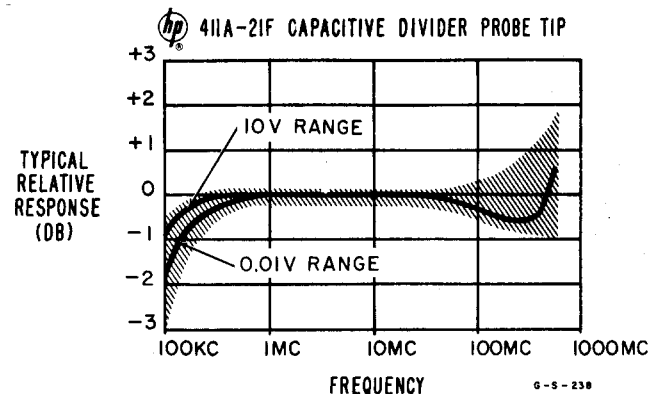

Figure 3-8. Frequency Response of Capacitive Divider

250 mc. Maximum input 1000 volts peak (dc + peak ac). Shunt capacity 2 pf. Division accuracy $\pm 1\%$. Typical frequency response with voltage and frequency is shown in figure 3-8.

3-16. MAKING PROBE TIPS. For special applications where none of these probe tips are suitable you may make your own probe tip. The signal must be coupled through a blocking capacitor to the center conductor (terminal) of the diode cartridge. The ground-return path should go to the outer conductor of the cartridge. The blocking capacitor used should be 130 pf $\pm 1\%$, stock no. 0150-0067, high leakage resistance type (mylar), and have a high enough voltage rating to block any dc. This blocking capacitor is necessary for the operation of the millivoltmeter and should be used even if the signal source has no dc component.

3-17. SELECTION OF PROBE TIP.

3-18. In choosing the proper probe tip, besides the obvious selection of coaxial or non-coaxial types, other properties of the probes must be considered. For instance, at 25 mc either the pen-type tip or the vhf tip may be used. However, the vhf has less shunt capacity and therefore should be used in high impedance applications, or where the least disturbance to the circuit is desired. In a similar manner all the specifications for the probe tips should be considered when selecting the best one for the application.

3-19. INSTALLATION OF PROBE TIPS.

3-20. After the proper probe tip has been selected, install it on the probe body by loosening the locking collar and unscrewing the present probe tip, if any, and screwing the new probe tip in its place. Screw the new probe tip down until it just bottoms.

CAUTION

Excessive torque will destroy the cartridge.

3-21. Screw the collar up to lock the probe tip in place. Keep the diode cartridge which fits into the probe tip clean. Do not touch the cartridge when installing the new probe tip. Run the locking collar tightly against the rear of the probe tip (be sure the probe tip does not rotate while the locking collar is being tightened).

3-22. MECHANICAL METER-ZERO.

3-23. When meter is properly zero set, pointer rests over the zero calibration mark on the meter scale when instrument is 1) at normal operating temperature, 2) in its normal operating position, and 3) turned off. Zero-set as follows to obtain best accuracy and mechanical stability:

a. Allow the instrument to operate for at least 20 minutes; this allows meter movement to reach normal operating temperature.

b. Turn instrument off and allow 30 seconds for all capacitors to discharge.

c. Rotate mechanical zero-adjustment screw clockwise until meter pointer is to left of zero and moving upscale toward zero.

d. Continue to rotate adjustment screw clockwise; stop when pointer is right on zero. If pointer overshoots zero, repeat steps c and d.

e. When pointer is exactly on zero, rotate adjustment screw approximately 15 degrees counter clockwise. This is enough to free adjustment screw from the meter suspension. If pointer moves during this step you must repeat steps c through e.

3-24. ZERO ADJUSTMENT.

3-25. Procedure for adjusting the ZERO control is given in figure 3-9. As this control is turned counter-clockwise it has control until the meter reaches zero. When the meter reads below zero, the action of the ZERO control is sluggish. However, the zero does not always have to be set accurately. A slight error in zero-setting becomes less important (at a square-law rate) as the input voltage is increased. For example, if the zero-set is off 1 minor division, this would be about 0.8 μv of dc, equivalent to about 0.2 mv of rf. At 1 mv of rf (1/10th full scale) about 15 μv dc is developed at the probe output, meaning that the error in zero-set would be only 5% of the reading. At full scale it would only be about 0.05%.

3-26. If this probe tip is connected to a test set-up which is at a different temperature than the probe tip the zero indication will drift until both diodes in the probe are at the same temperature.

3-27. INTERPRETING READING.

3-28. No interpretation of the meter reading is necessary with continuous sinusoidal signals. This means for almost all of your measurements the reading on the meter will be the rms value of the signal. The usual conditions apply that the frequency of the signal must be in the range of the instrument and the dc component is not measured.

3-29. When a non-sinusoidal waveform is measured the reading obtained must be interpreted with respect to the particular waveform being measured. The dc voltage developed by the signal is compared with an almost equal dc voltage developed by the sinusoidal voltage from the 100 kc oscillator. Since the waveforms of the two voltages are different, the peak voltage needed to develop these equal dc voltages is different.

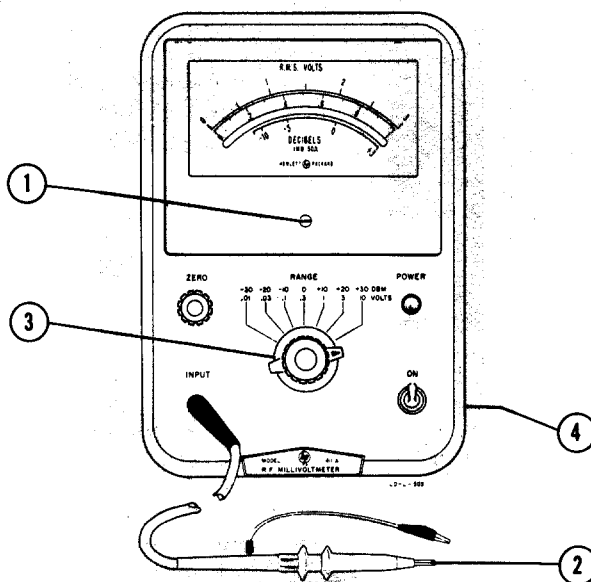

The needle on the meter should be on zero when the instrument is off. If it is not, proceed as follows:

1. Adjust mechanical meter zero-set as in paragraph 3-22.
2. To check the electrical zero turn instrument on and remove all input to the probe (short probe tip if vhf, place in radiation-free cavity if coaxial).
3. Turn the RANGE switch to the 1 VOLT or greater range. The meter pointer should be on zero. If it is not, the cathode follower bias must be reset. Turn RANGE switch to the blank, fully clockwise, position as shown. In this position the feedback loop is opened.
4. Adjust BIAS ADJ control (on rear) until meter reads zero. To set the electrical ZERO control, follow the instructions given in figure 3-10.

Figure 3-9. Electrical Zero Adjustment

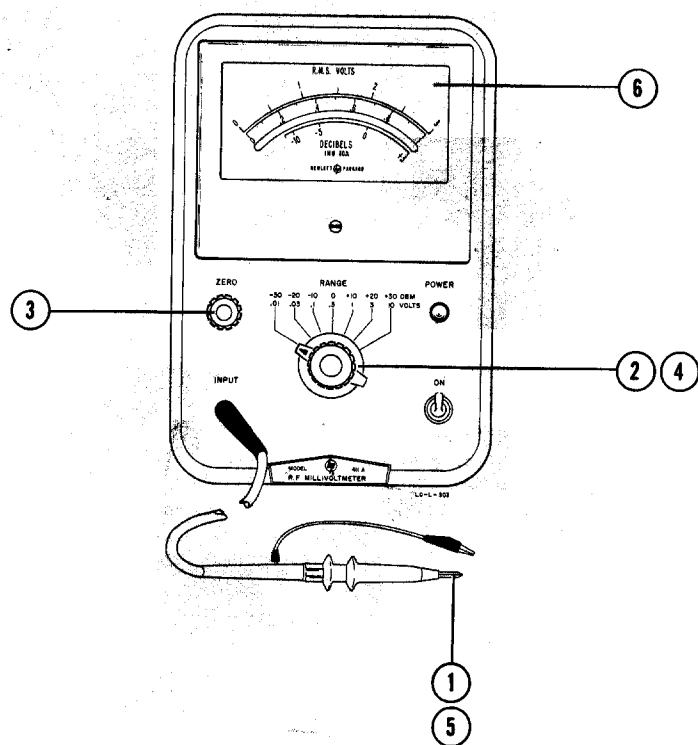

1. Remove input to probe (see figure 3-9).
2. Switch RANGE switch to 0.01 volt range.
3. Turn the ZERO control fully clockwise. Now turn ZERO control counterclockwise until the meter reads zero.
4. Turn RANGE switch to the range containing the expected voltage (it is unnecessary to readjust ZERO control).
5. Connect probe tip to point to be measured. Connect ground lead (if any) to ground.
6. Read amount of voltage on appropriate scale.
7. If the rf voltage being measured is nonsinusoidal, multiply the reading by the appropriate correction factor (see paragraph 3-27, Interpreting the Reading). This is the true value.

Figure 3-10. Operating Procedure

SECTION IV PRINCIPLES OF OPERATION

4-1. INTRODUCTION.

4-2. This instrument consists essentially of a self-balancing servo system using semiconductor diodes as detector elements. The servo output, which is produced by detecting a low-frequency feedback signal, is compared to the detected rf and adjusted automatically so as to make the difference voltage very nearly zero. The detection characteristics of the two diodes, the rf detector, and the feedback detector are carefully matched by calibration. Thus, since these outputs are equal, the low-frequency feedback signal must have the same effective amplitude as the input rf. Linear readings are obtained by metering the low-frequency feedback (which is linear) at a high level.

4-3. Referring to the block diagram, figure 4-1, the ac voltage to be measured is coupled through the probe-tip capacitor and applied across the rf diode detector CR1 to be rectified. The rectified signal is compared in the modulator (V1 and V2) with a rectified signal coming from the comparison diode

(CR2). The difference between these two dc signals is amplified in the chopper amplifier (V3A & B and V4A). The amplified signal is demodulated by the demodulator (V5 & 6) and fed to the cathode follower output stage (V4B).

4-4. The direct current output of the cathode follower goes to the 100 kc oscillator (Q1) and the modulator (Q2). This signal controls the amplitude of the 100 kc fed to the power amplifier (V7). The output of V7, taken from the cathode, is rectified by CR14 and the direct current causes the meter to read upscale.

4-5. The 100 kc signal is also fed, through the range attenuator, to the ac feedback diode detector CR2. This diode rectifies the 100 kc and feeds a direct current, which is proportional to the 100 kc, through R9 and R17 to the comparator and modulator V2. This dc signal is compared with the dc signal developed by the rf signal being measured. The difference between these two dc signals is the signal which is chopped and amplified in the chopper amplifier.

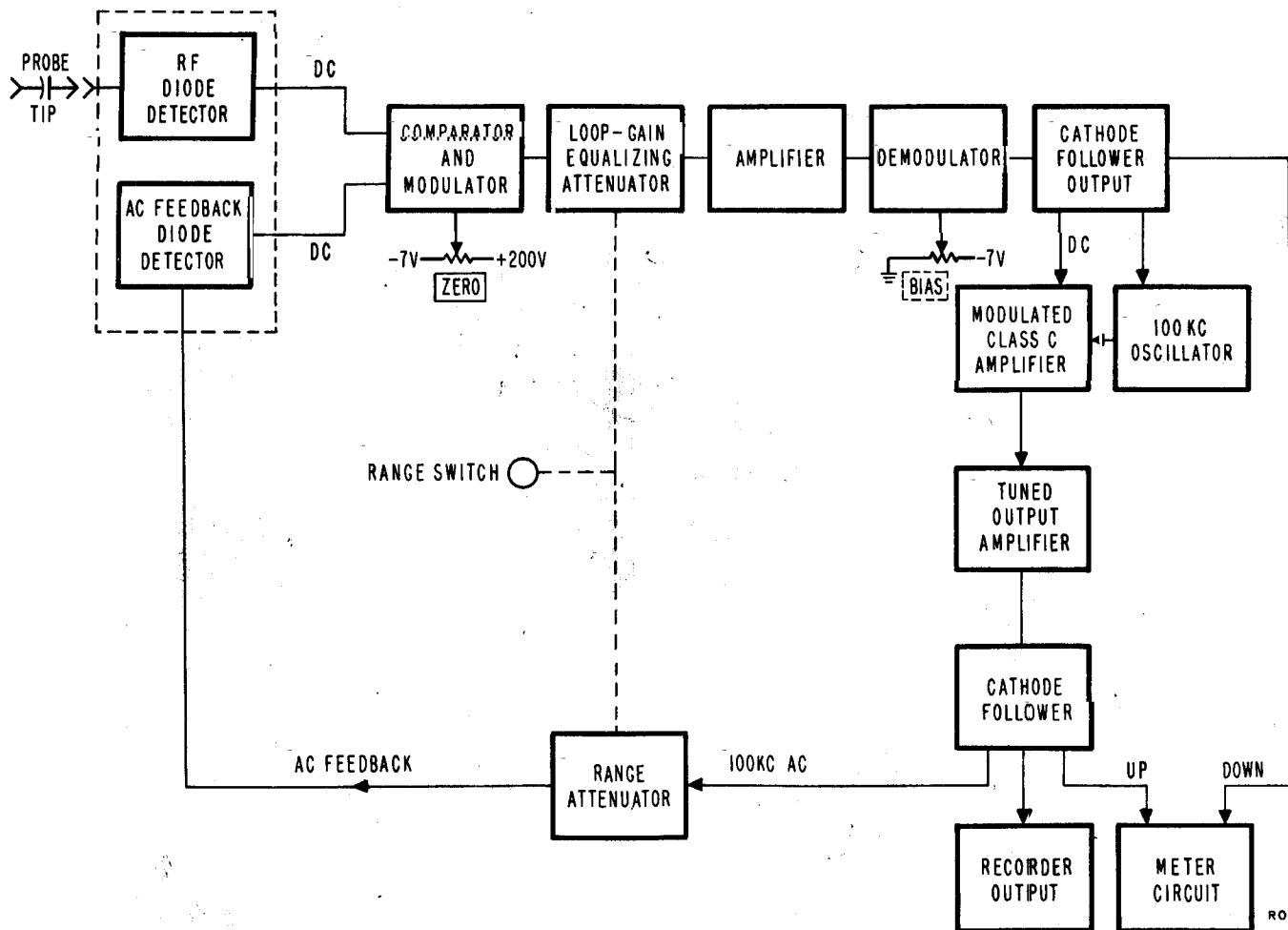

Figure 4-1. Block Diagram

4-6. Since the gain of the amplifier is high and the feedback loop is connected as a servo system, the level in the amplifier will automatically adjust itself until the dc developed by the 100 kc very nearly equals the dc developed by the signal being measured. The range attenuator sets the ratio of the 100 kc feedback. The loop-gain equalizing attenuator keeps the loop-gain constant when the range attenuator is switched.

4-7. PROBE.

4-8. Referring to the schematic diagram, note that the probe tips may be substituted for one another so that the particular one best suited for a particular application may be used. All probe tips contain a blocking capacitor. In addition to blocking dc, this capacitor is the charging capacitor for the rf detector diode CR1.

4-9. In the probe body itself there is a cartridge containing the two detector diodes and associated components in close thermal contact. As the ambient temperature of the probe changes, the temperature of both diodes changes in a similar manner tending to balance out the changes in rectification characteristics with temperature.

4-10. MODULATOR.

4-11. The signal to be measured, which is coupled through the probe-tip capacitor, is rectified by CR1. The resultant dc is filtered by R10 and C11, and applied to a chopper-type modulator containing two photo-conductive cells, V1 and V2, which are alternately exposed to light. The output of the modulator is a square wave which is proportional to the difference between the rectified comparison signal and the rectified incoming signal.

4-12. CHOPPER AMPLIFIER.

4-13. The modulator output is amplified by the chopper amplifier. This amplifier is a standard audio amplifier with a gain-equalizing attenuator between stages. This attenuator, together with the attenuator in the feedback path, keeps the loop gain approximately constant as the ranges are switched. Note that as attenuation is switched into the gain-equalizing attenuator, it is switched out of the feedback path.

4-14. DEMODULATOR.

4-15. The demodulator assembly converts the chopped and amplified signal back to dc and consists of two photocells as in the modulator. They are illuminated by the same light chopped as the modulator; however, in this case the input is a chopped signal and the output is dc. In respect to phasing, when V1 is illuminated (low resistance) V6 is also illuminated, while V2 and V5 are dark. On the other half-cycle V1 and V6 are dark while V2 and V5 are illuminated. The chopper is a synchronous motor which chops a light beam at the rate of 5/6th of the line frequency. The line frequency is avoided to prevent any dc offset due to hum in the amplifier.

4-16. CATHODE FOLLOWER.

4-17. The dc signal from the demodulator is fed to a cathode follower V4B which provides a low impedance input to the modulator Q2 and the down-scale meter circuit, CR11 & 12 and R55. The down-scale meter circuit works as a switch to furnish a current which drives the needle on the meter down-scale instead of up-scale.

4-18. Since the normal signal circuit will only move the meter needle up-scale, some provision must be made to indicate a down-scale drift, otherwise the system may drift off zero in the negative direction without any indication on the meter.

4-19. The grid of the cathode follower V4B is kept from going positive by the clamp CR3. This prevents the voltage at the cathode from rising so high as to exceed the collector voltage ratings of Q1 and Q2. The normal output from the cathode follower (pin 1) is positive. However, if for any reason this voltage goes negative, CR11 will conduct and drive the meter down-scale. Crystal rectifier CR12 is merely a clamp to ensure that this circuit only drives the meter down-scale. Actually, around zero voltage both circuits are driving the meter which gives positive control of this meter indication even at low signal levels.

4-20. MODULATOR AND 100 KC OSCILLATOR.

4-21. A direct current signal is also fed from the cathode follower to both the modulator and 100 kc oscillator. This signal amplitude modulates the 100 kc signal generated by Q1. This modulated signal then passes through a tuned filter consisting of C66, L3, and C68 to the power amplifier. This filter removes any harmonics of 100 kc present in the signal.

4-22. POWER AMPLIFIER.

4-23. Tube V7 is a tuned rf amplifier which amplifies the 100 kc signal. This amplifier furnishes a signal to the up-scale meter circuit consisting of R51 & 53, CR13, CR14, and C51. This meter circuit is an average detector operating at a high level.

4-24. A similar circuit is also provided for the recorder output circuit except that this circuit also has a variable attenuator R54 which may be used to calibrate the recorder.

4-25. FEEDBACK.

4-26. The output from the power amplifier is divided by C72, 73, and 74 into two voltage levels approximately 10 db apart. These two voltages are the input for the feedback attenuator consisting of C82 through C91. The feedback attenuator selects one of these voltage levels and one or more of the capacitors for each range. There is an additional (unmarked) position at the 10 VOLT end of the feedback attenuator where the feedback loop may be opened for test purposes.

SECTION V MAINTENANCE

5-1. INTRODUCTION.

5-2. Components within Hewlett-Packard instruments are conservatively operated to provide maximum instrument reliability. In spite of this, parts within an instrument may fail. If you adopt a systematic approach to troubleshooting, the instrument can be repaired with a minimum amount of "down time".

5-3. Check the tubes if an instrument is completely inoperative and there is no obvious fault, such as a burned-out fuse, defective power cable, or power line failure. Tube replacement will, in most cases, restore operation. See paragraph 5-11 for tube replacement information. Information in paragraph 5-16, Troubleshooting, in this manual will assist you when troubles are more complex.

5-4. If the instrument is operating, the zero-adjustment procedure, figure 3-9, is a fast method of checking the basic adjustments and operation of the instrument.

5-5. Standard, readily available components are used for manufacture of Hewlett-Packard instruments whenever possible. These parts can be obtained from your Hewlett-Packard sales office or directly from the factory. Your Hewlett-Packard sales office maintains a parts stock for your convenience.

5-6. TEST EQUIPMENT.

5-7. Test equipment recommended for use in maintaining and servicing the Model 411A is listed in table 5-1. Equipment having similar characteristics can be substituted for the equipment listed.

Table 5-1. Recommended Test Equipment

Instrument Type	Required Characteristics	Use	Model
AC Voltmeter	± 3% accuracy at 100 kc, 0.001-30 volt	Measuring ac signals	Ⓜ Model 400D/H/L
DC Voltmeter	± 2% accuracy, 0.003 to 1000 volt	Measuring dc voltages	Ⓜ Model 412A
Oscillator	500 kc at 10 volt	Calibration	Ⓜ Model 200CD
Attenuator	Adjustable to at least 60 db in 1 db steps	Calibration	Ⓜ Model 355B
Variable Transformer	Continuously adjustable from 100 to 130 volts, equipped with a monitor voltmeter accurate within ± 1 volt	Checking for operation on high and low lines.	Superior Electric 3PN116
Test Oscillator	10 mc to below 100 kc	Low frequency response	Ⓜ Model 650A
Signal Generator	10 to 480 mc and 480 to 1000 mc	High frequency response	Ⓜ Model 608C Ⓜ Model 612A
Type N "T" Connector	Flat frequency response ± 1 db 1 mc- 1 kmc	Frequency response	Ⓜ 411A-21D
Standing Wave Indicator	Reads swr on slotted line used	Frequency response	Ⓜ Model 415B
Slotted Line	Operating frequency 1 kmc to 500 mc or below	Frequency response	Ⓜ Model 805C
Coaxial Slide-Screw Tuner	Operating frequency 1 kmc to 500 mc or below	Frequency response	Ⓜ Model 872A
Power Meter	Operating frequency 1 kmc to 500 mc or below	Frequency response	Ⓜ Model 431C with Ⓜ Model 478A

5-8. REMOVING THE CABINET.

5-9. Disconnect the power cord while removing the cabinet. The cabinet is held in place by two screws in the back. Remove these two screws and slide the instrument forward out of the cabinet.

WARNING

Dangerous potentials are exposed when this instrument is removed from the cabinet.

5-10. CARTRIDGE AND/OR CABLE REPLACEMENT.

5-11. To remove the cartridge first remove the probe tip, if any. Loosen the cartridge and the probe handle from the cable by loosening the number 4 allen screws in the handle and in the shell around the cartridge. Note that to loosen the cartridge the allen screw must be screwed in (clockwise, opposite to the normal manner of loosening a screw). Push the cable through the handle. Remove the cartridge without getting fingerprints on it by using gloves or a handkerchief to pull the cartridge from the socket. Install the new cartridge in the reverse order.

5-12. To replace the probe cable cut the individual wires going to the 411A-65C board where they come from the shield. Loosen the two nuts holding the cable to the front panel and slide the nuts off the cable. Pull the cable from the front panel. Install new cable in reverse order soldering the wires from the cable in place of the wires with the same color which are still attached to the 411A-65C board.

5-13. TUBE REPLACEMENT.

5-14. Check tubes by substitution rather than by using a "tube checker". The results obtained from the "tube checker" may be misleading. Before removing a tube mark it, so that if the tube is good it can be returned to the same socket. Replace only tubes proved to be weak or defective.

5-15. Any tube with corresponding standard EIA (JEDEC) characteristics can be used as a replacement.

Refer to table 5-2 Component Replacement for additional tests which may be required when changing tubes or transistors.

5-16. TROUBLESHOOTING.

5-17. Adopting a systematic approach to troubleshooting will enable you to find the trouble in the shortest possible time and eliminate the possibility of damaging the transistors or other parts of the instrument. Whenever trouble is suspected perform the following steps in the order given until the trouble is located.

5-18. Inspect for burned-out tubes, burned-out modulator light bulbs, overheated resistors, etc.

5-19. MEASURE POWER SUPPLY VOLTAGES.

5-20. If the instrument is not completely dead the trouble may be either in the power supply or in the instrument itself. Check the power supply voltages first, as follows:

a. Turn the RANGE switch to the extreme clockwise (unmarked) position. In this switch position the feedback is disconnected. With normal ac input voltage measure the following voltages with a dc voltmeter:

- (1) +340 volt supply at pin 7 of V101. This voltage must be greater than +320 volts, less than +360 volts. This voltage must not change more than 45 volts for a change in line voltage from 115 to 102 volts (230 to 204 volts for 230 volt model). Plug the Model 411A into the variable transformer as a power source for this measurement. If the dc voltage change is greater than 45 volts try replacing V101.
- (2) +210 volt supply at pin 1 of V102. This voltage must be greater than +194 volts, less than +222 volts. The dc voltage change must not exceed 3 volts for a change in line voltage from 102 to 128 volts. If the dc voltage change is too great try replacing V3.

Table 5-2. Component Replacement

When replacing the following components perform the additional test indicated.		
Reference Designator	Component Name	Perform These Tests
Q1 Q2	Transistor Transistor	Retune Modulator/Amplifier par. 5-26 Retune Modulator/Amplifier par. 5-26
V1 V2	Photocell Photocell	None None
V3 V4 V5 V6 V7	Vacuum Tube Vacuum Tube Photocell Photocell Vacuum Tube	Readjust Hum Balance par. 5-35 Readjust Bias par. 5-34 None None Retune Modulator/Amplifier par. 5-26

- (3) +200 volts at C15. This voltage must be greater than +164 volts, less than +210 volts. If not, try changing V101, 102, or 103.
- (4) -7 volts at the counterclockwise arm (terminal with two wires) of ZERO control (R13). This voltage must be more negative than -6.3 volts and less than -7.5 volts. This voltage must not change more than 0.1 volt for a line voltage change of 102 to 128 volts (204 to 256 volts for 230 volt model). If not change CR4.
- (5) +7 volts at the clockwise arm (terminal with single wire lead) of the ZERO control (R13). This voltage must be greater than +5.0 volts, less than +12 volts. If not, check -7 volt and +210 volt supplies and R12 and 13.

b. With an ac voltmeter measure the voltages at terminals 4 and 5 on T101. The sum of these voltages should be between 5.9 and 6.7 vrms with 115 volt input (230 volt on 230 volt model). If not, check for shorts in tubes and wiring or replace T101.

5-21. MEASURE RIPPLE.

5-22. With the Model 411A still set to the unmarked, open loop, position measure the ripple voltages with the ac voltmeter. Use a shielded lead and connect the shield lead to the ground lug near C15 on the outside of the 411A chassis.

5-23. With an ac voltmeter check the following voltages:

- a. +340 volt supply at pin 7 of V101. The ripple voltage should be 1.5 vrms or less. If not, check C102, V101.
- b. +210 volt supply at pin 1 of V102. The ripple voltage should be 30 millivolts rms or less. If not, check C101, 102, 103 and V102, 103.
- c. -7 volt supply at the counterclockwise arm terminal with two wires of the ZERO control (R13). The ripple voltage must be 3 millivolts or less. If not, check CR4.
- d. +200 volt supply at C15. The ripple voltage must be 0.3 millivolts rms or less. If not, check C15.

Note

Move RANGE switch off open-loop position.

5-24. DOWNSCALE METER CIRCUIT.

Note

All of the following procedures assume no input to the probe. If the instrument picks up signals of any kind, short out the probe tip with as short a lead length as possible, or place the tip in a radiation-free cavity.

5-25. Short out the demodulator assembly (V5 and V6) by connecting a clip lead between the lead on the demodulator assembly A2 going to C46 and the center terminal of A2. The meter should indicate below zero with the Bias Adj. control on the rear apron set fully counterclockwise. Set Bias Adj. control to obtain a zero meter indication. Remove the clip lead.

5-26. MODULATOR/AMPLIFIER TUNING.

5-27. Since this instrument is fundamentally a servo-system, a fault anywhere in the instrument will cause a faulty reading on the meter. Finding the particular stage causing the trouble may be difficult with an instrument so dependent upon feedback. The following procedure will enable you to break the feedback loop and determine whether the fault is in the feedback loop or the probe and chopper sections. This test disables the probe and chopper sections and measures the reaction of the feedback section.

- a. Disable the chopper/amplifier section by shorting the terminal on the demodulator A2 which goes to C46 and the center terminal of A2.
- b. Set Bias Adj. control on rear apron fully clockwise, and the RANGE switch to the 3 VOLTS position.
- c. Connect an ac voltmeter (30 volt range) to measure the voltage to ground at the "10-volt bus" (wire going to terminal marked BRN/WHT on 411A-65E etched circuit board).
- d. Connect a dc voltmeter (+300 volt range) to measure the voltage to ground at pin 5 of V7.
- e. Adjust L3 for a peak indication of the ac voltmeter.
- f. Adjust L4 for a peak indication on the dc voltmeter.
- g. Repeat step e and step f until final "touch up" of tuning causes no further increase of readings on the voltmeters. Tuning of one coil interacts with the tuning of the other coil.

5-28. When tuning is completed, voltage on the dc voltmeter must be greater than +210 volt and less than +280 volt. If this voltage is high do NOT detune L3 or L4 to meet these limits. The trouble causing this high voltage must be eliminated. The voltage on the ac voltmeter should exceed 11 vrms. If this voltage fails to exceed 11 vrms despite careful tuning, the trouble could be a poor V4 or V7. Under these conditions, if the dc voltage on pin 1 of V4B is more than +4.3 volts, then V4B is satisfactory.

5-29. Return the instrument to normal operating condition:

- a. Lock the adjusting screws on L3 and L4; do this CAREFULLY so as not to disturb adjustment.
- b. Disconnect the meters and the clip lead.
- c. Adjust Bias Adj. control on rear apron to set meter to zero with RANGE switch set full clockwise.

SERVICING ETCHED CIRCUIT BOARDS

Excessive heat or pressure can lift the copper strip from the board. Avoid damage by using a low power soldering iron (50 watts maximum) and following these instructions. Copper that lifts off the board should be cemented in place with a quick drying acetate base cement having good electrical insulating properties.

A break in the copper should be repaired by soldering a short length of tinned copper wire across the break.

Use only high quality rosin core solder when repairing etched circuit boards. NEVER USE PASTE FLUX. After soldering, clean off any excess flux and coat the repaired area with a high quality electrical varnish or lacquer.

When replacing components with multiple mounting pins such as tube sockets, electrolytic capacitors, and potentiometers, it will be necessary to lift each pin slightly, working around the components several times until it is free.

WARNING: If the specific instructions outlined in the steps below regarding etched circuit boards without eyelets are not followed, extensive damage to the etched circuit board will result.

1. Apply heat sparingly to lead of component to be replaced. If lead of component passes through an eyelet in the circuit board, apply heat on component side of board. If lead of component does not pass through an eyelet, apply heat to conductor side of board.

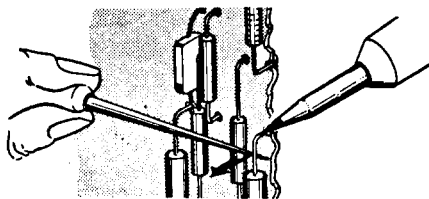

2. Reheat solder in vacant eyelet and quickly insert a small awl to clean inside of hole. If hole does not have an eyelet, insert awl or a #57 drill from conductor side of board.

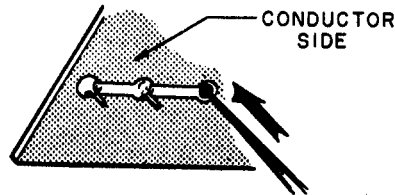

3. Bend clean tinned leads on new part and carefully insert through eyelets or holes in board.

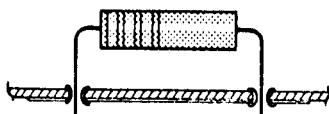

4. Hold part against board (avoid overheating) and solder leads. Apply heat to component leads on correct side of board as explained in step 1.

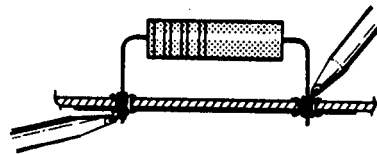

In the event that either the circuit board has been damaged or the conventional method is impractical, use method shown below. This is especially applicable for circuit boards without eyelets.

1. Clip lead as shown below.

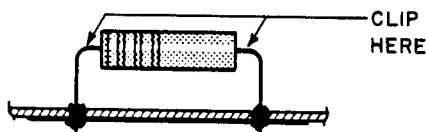

2. Bend protruding leads upward. Bend lead of new component around protruding lead. Apply solder using a pair of long nose pliers as a heat sink.

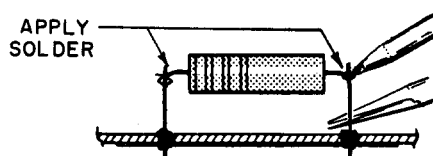

This procedure is used in the field only as an alternate means of repair. It is not used within the factory.

Figure 5-1. Servicing Etched Circuit Boards

c. Connect the probe of the 411A across the same voltage as the ac voltmeter (see figure 5-2). Make the mechanical and electrical zero-setting just before connecting the probe (see figure 3-9).

d. Set the RANGE switch on the Model 411A to the 10 VOLT range.

e. Adjust the attenuator and the AMPLITUDE control on the oscillator until the ac voltmeter reads exactly 10 volts (taking into account any correction factors).

f. Read the value indicated on the 411A. If this reading is within $\pm 3\%$ of 10 volts proceed to the next lowest range; if not, adjust R53 (on chassis near rear of range switch) until it does. Adjustment of R53 (10 volt Cal) affects all ranges. The other calibration adjustments are non-interacting.

g. Repeat steps e and f on all of the other ranges adjusting the calibration adjustments, if necessary, as follows:

Range (volts)	Adjustment (figure 5-3)
3	C87
1	C86
.3	C85
.1	C84
.03	C83

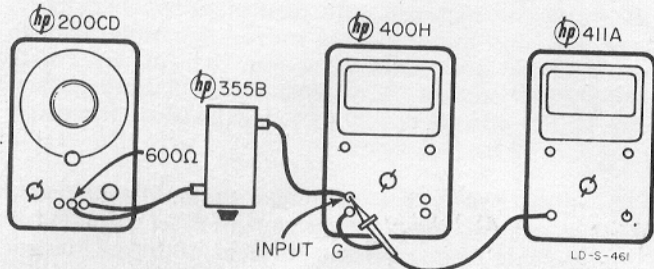

Figure 5-2. Calibration Test Setup

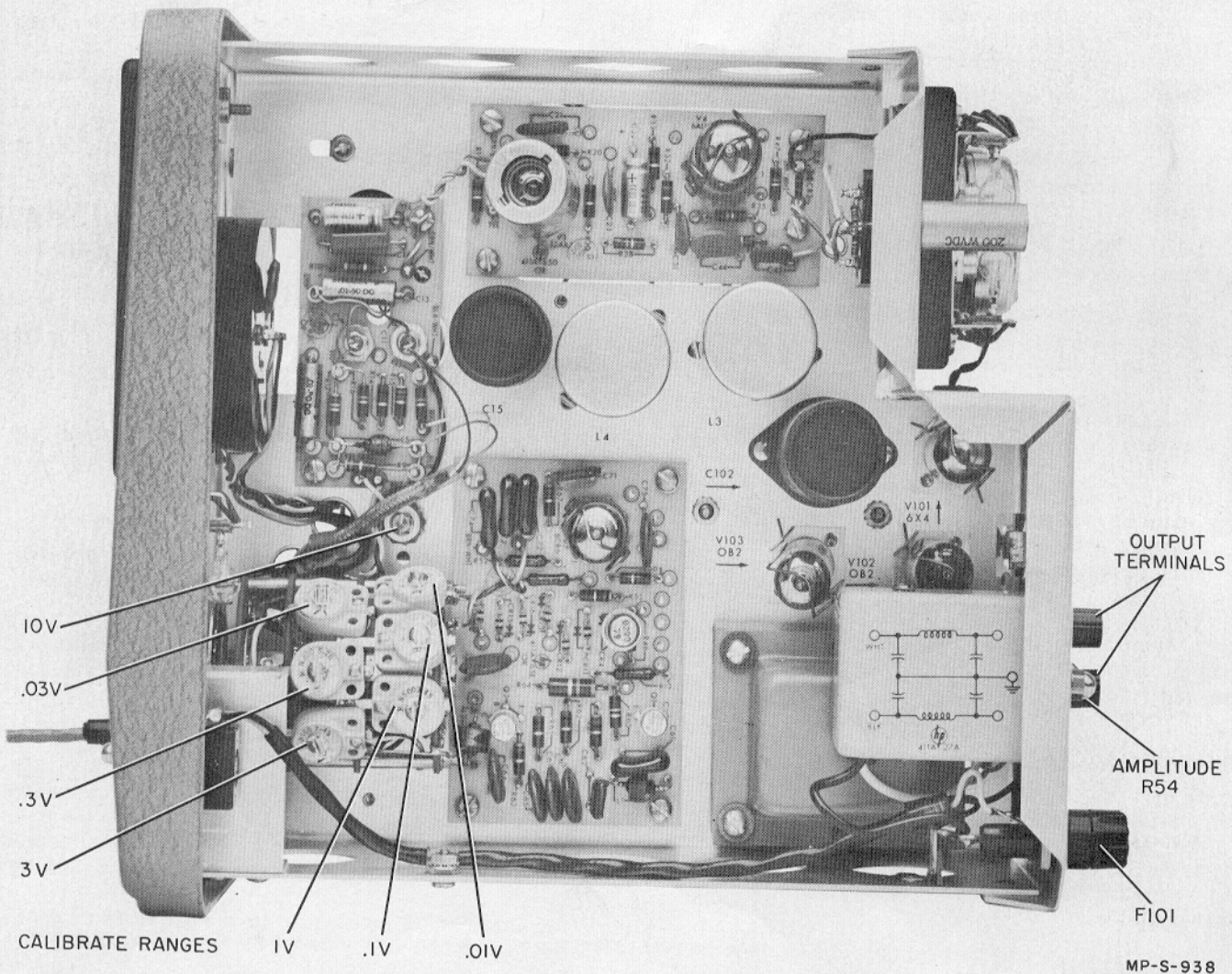

Figure 5-3. Right Side Internal View

In order for the 415-B to function, it is necessary that the output of the oscillator be square-wave modulated @ 1 KHz.

It is also necessary to "re-flatten" the line whenever the oscillator frequency is changed.

However, once the line is "flattened" for a given frequency, the modulation must be removed and the oscillator operated CW while the measurements are taken with the 411-A and 431-B.

Beware of a considerable increase in oscillator output when oscillator is switched to CW.

mfg

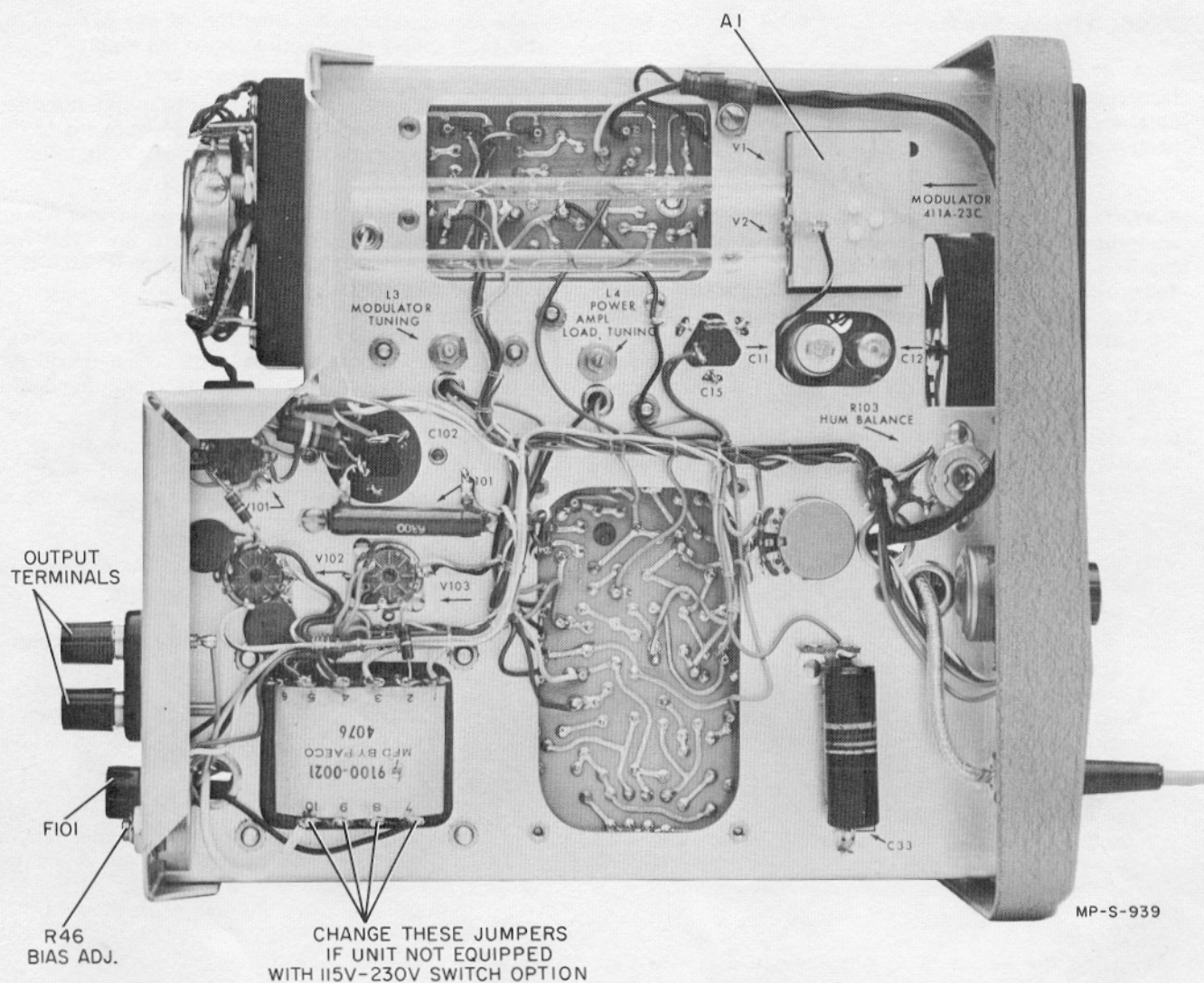

Figure 5-5. Left Side Internal View

j. Set the signal generator for CW output and adjust the level until the 431A reads approximately 16.2 microwatts. The 411A should read within 1 db (11%) of 90% of full scale on the 0 to 1 scale of the 411A. If not, recheck calibration.

Note

This reading and all those which follow should be checked with the 411A at 102 and 128 volts ac input set by means of a variable transformer. These readings should also be within the specifications. If not, refer to paragraph 5-16 Troubleshooting.

k. Adjust the output of the signal generator to exactly 90% of full scale on the 411A. Note the reading on the Model 431A.

m. Change the frequency of the signal generator to the frequency limit of the probe tip (or the frequency

limit of the signal generator, whichever is lower) and adjust the output level to the same reading obtained in step k.

n. The reading on the 411A should be within 1 db (11%) of 90%. From 50 to 150 mc the reading should be within 6%, and from 1 mc to 50 mc the reading should be within 3%. If the reading is not within these limits repeat the procedure to make sure no error in testing has occurred. If no error in testing can be found, replace the probe cartridge and recalibrate (paragraph 5-43) the instrument.

5-48. The previous procedure tests the probe on the square-law portion of its characteristics. To test the probe on its straight line portion of its characteristics repeat the above tests with the 411A set to the .3 VOLT range and 1.62 milliwatts input as read on the Model 431A.

REFERENCE DESIGNATORS

B101
C101 - 103
CR 4
DS101-105
F101
FL1
R100 - 103
S101, 102
T101
V101 - 103

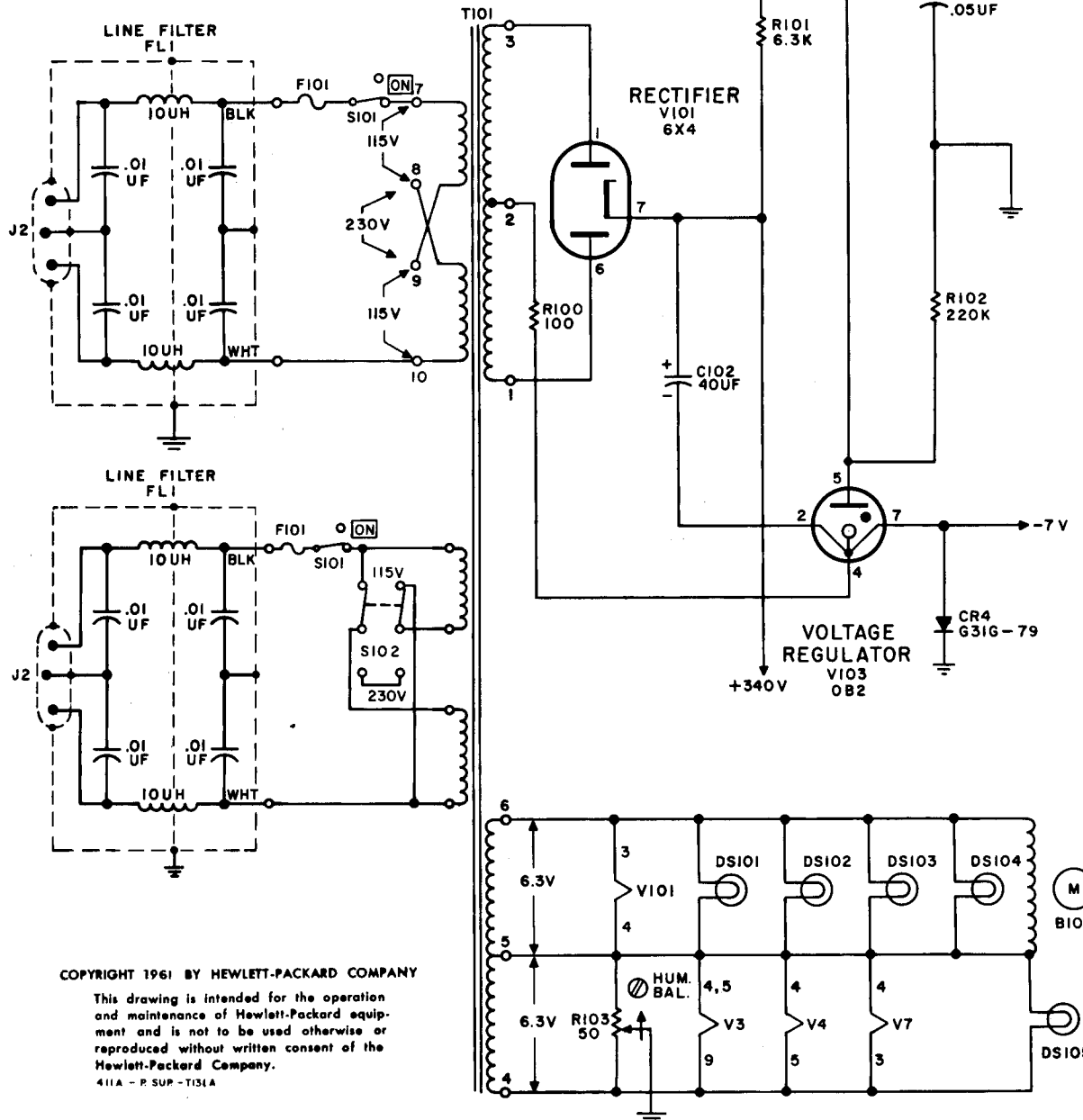

COPYRIGHT 1961 BY HEWLETT-PACKARD COMPANY

This drawing is intended for the operation and maintenance of Hewlett-Packard equipment and is not to be used otherwise or reproduced without written consent of the Hewlett-Packard Company.

411A - P SUP - T151A

Figure 5-6. Power Supply

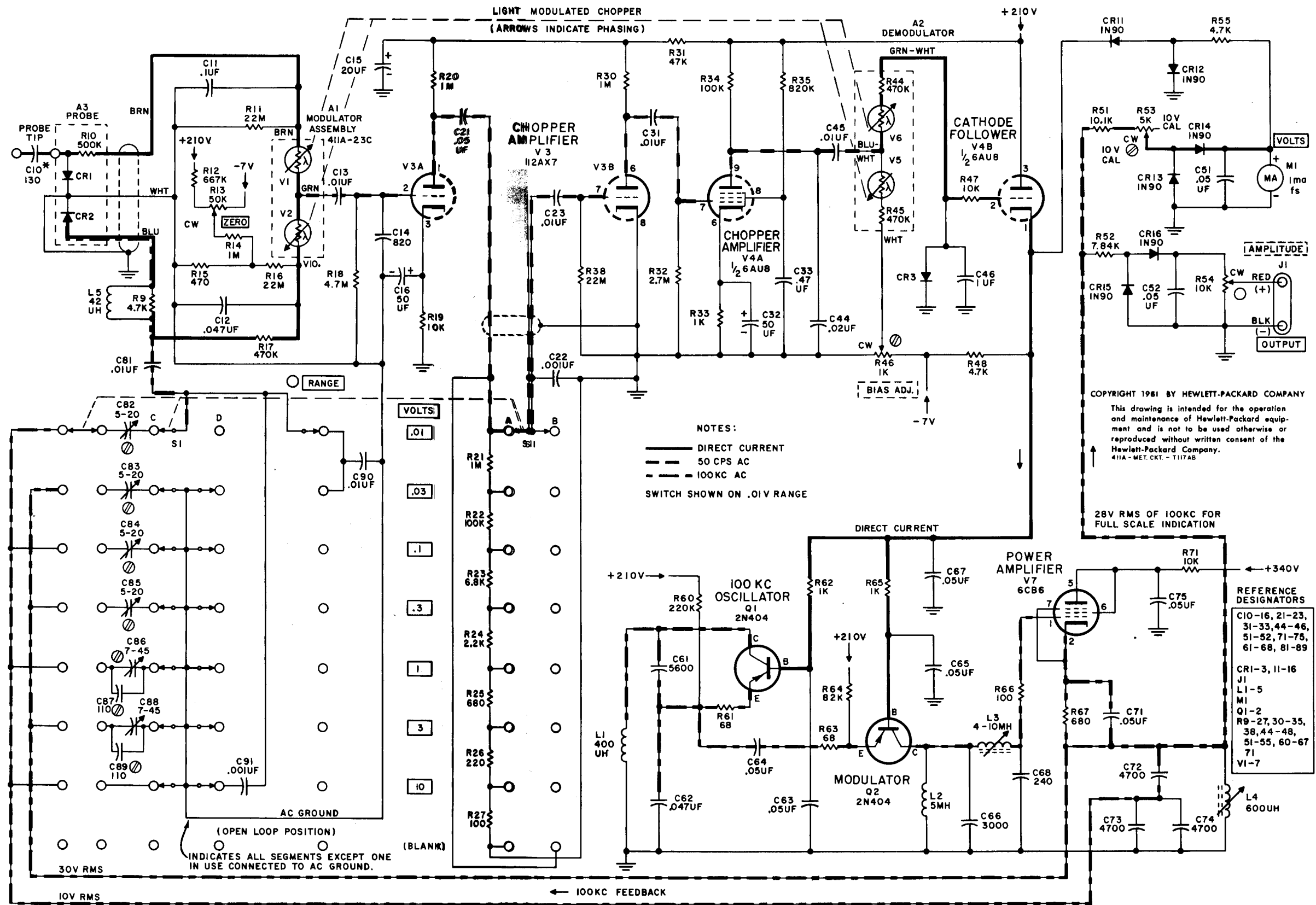

Figure 5-7. Voltmeter
5-11/5-12

SECTION VI

REPLACEABLE PARTS

6-1. INTRODUCTION.

6-2. This section contains information for ordering replacement parts. Table 6-1 lists parts in alpha-numerical order of their reference designators and indicates the description and $\text{\textcircled{P}}$ stock number of each part, together with any applicable notes. Table 6-2 lists parts in alpha-numerical order of their $\text{\textcircled{P}}$ stock numbers and provides the following information on each part:

- a. Description of the part (see list of abbreviations below).
- b. Manufacturer of the part in a five-digit code; see list of manufacturers in appendix.
- c. Typical manufacturer's stock number.
- d. Total quantity used in the instrument (TQ column).
- e. Recommended spare part quantity for complete maintenance during one year of isolated service (RS column).

6-3. Miscellaneous parts not indexed in table 6-1 are listed at the end of table 6-2.

6-4. ORDERING INFORMATION.

6-5. To order a replacement part, address order or inquiry either to your authorized Hewlett-Packard sales representative or to

CUSTOMER SERVICE
Hewlett-Packard Company
395 Page Mill Road
Palo Alto, California

or, in Western Europe, to

Hewlett-Packard S.A.
Rue du Vieux Billard No. 1
Geneva, Switzerland.

6-6. Specify the following information for each part:

- a. Model and complete serial number of instrument.
- b. Hewlett-Packard stock number.
- c. Circuit reference designator.
- d. Description.

6-7. To order a part not listed in tables 6-1 and 6-2, give a complete description of the part and include its function and location.

REFERENCE DESIGNATORS

<p>A = assembly B = motor C = capacitor CR = diode DL = delay line DS = device signaling (lamp) E = misc electronic part</p>	<p>F = fuse FL = filter J = jack K = relay L = inductor M = meter</p>	<p>P = plug Q = transistor R = resistor RT = thermistor S = switch T = transformer</p>	<p>V = vacuum tube, neon bulb, photocell, etc. W = cable X = socket XF = fuseholder XV = tube socket XDS = lampholder</p>
--	---	--	---

ABBREVIATIONS

<p>bp = bandpass bwo = backward wave oscillator</p> <p>c = carbon cer = ceramic cmo = cabinet mount only coef = coefficient com = common comp = composition conn = connection crt = cathode-ray tube</p> <p>dep = deposited det = detector</p> <p>EIA = Tubes and transistors selected for best performance will be supplied if ordered by $\text{\textcircled{P}}$ stock numbers; tubes or transistors meeting Electronic Industries' Association standards will normally result in instrument operating within specifications</p>	<p>elect = electrolytic encap = encapsulated</p> <p>f = farads fxd = fixed</p> <p>Ge = germanium grd = ground (ed)</p> <p>h = henries Hg = mercury</p> <p>imp = impregnated incd = incandescent ins = insulation (ed)</p> <p>K = kilo</p> <p>lin = linear taper log = logarithmic taper</p> <p>m = milli = 10^{-3} M = megohms ma = milliamperes minat = miniature mfg = metal film on glass mfr = manufacturer</p>	<p>mtg = mounting my = mylar</p> <p>NC = normally closed Ne = neon NO = normally open NPO = negative positive zero-zero temperature coefficient nsr = not separately replaceable</p> <p>obd = order by description</p> <p>p = peak pc = printed circuit board pf = picofarads = 10^{-12} farads pp = peak-to-peak piv = peak inverse voltage pos = position(s) poly = polystyrene pot = potentiometer rect = rectifier</p>	<p>rot = rotary rms = root-mean-square rmo = rack mount only</p> <p>s-b = slow-blow Se = selenium sect = section(s) Si = silicon sl = slide</p> <p>td = time delay TiO₂ = titanium dioxide</p> <p>tog = toggle tol = tolerance trim = trimmer twt = traveling wave tube</p> <p>var = variable w/ = with W = watts ww = wirewound w/o = without</p> <p>* = optimum value selected at factory, average value shown (part may be omitted)</p>
--	--	---	---

Table 6-1. Reference Designation Index

Circuit Reference	Ⓢ Stock No.	Description	Note
A1	411A-23C	Assy, modulator: includes V1, 2	
A2	412A-23B	Assy, demodulator: includes V5, 6	
A3	411A-21A-3	Assy, detector cartridge: includes CR1, CR2, R10	
B1 thru B100		Not assigned	
B101		nsr; part of chopper assy (see Misc.)	
C1 thru C9		Not assigned	
C10	0150-0067	fxd, cer, 130*pf $\pm 2\%$, 500 vdcw	
C11	0170-0030	fxd, poly, 0.1 μ f $\pm 10\%$, 50 vdcw	
C12	0170-0077	fxd, poly, 0.047 μ f $\pm 10\%$, 50 vdcw	
C13	0170-0029	fxd, poly, 0.01 μ f $\pm 10\%$, 50 vdcw	
C14	0140-0091	fxd, mica, 820 pf $\pm 5\%$, 500 vdcw	
C15	0180-0011	fxd, elect, 20 μ f, 450 vdcw	
C16	0180-0033	fxd, elect, 50 μ f, 6 vdcw	
C17 thru C20		Not assigned	
C21	0150-0052	fxd, cer, 0.05 μ f $\pm 20\%$, 400 vdcw	
C22	0150-0050	fxd, cer, 1K pf, 600 vdcw	
C23	0150-0012	fxd, cer, 0.01 μ f $\pm 20\%$, 1000 vdcw	
C24 thru C30		Not assigned	
C31	0150-0012	fxd, cer, 0.01 μ f $\pm 20\%$, 1000 vdcw	
C32	0180-0033	fxd, elect, 50 μ f, 6 vdcw	
C33	0160-0015	fxd, paper, 0.47 μ f $\pm 10\%$, 200 vdcw	
C34 thru C43		Not assigned	
C44	0150-0024	fxd, cer, 0.02 μ f $\pm 80\%$ -20%, 600 vdcw	
C45	0150-0012	fxd, cer, 0.01 μ f $\pm 20\%$, 1000 vdcw	
C46	0160-0029	fxd, paper, 1 μ f $\pm 20\%$, 200 vdcw	
C47 thru C50		Not assigned	
C51, 52	0150-0052	fxd, cer, 0.05 μ f $\pm 20\%$, 400 vdcw	
C53 thru C60		Not assigned	
C61	0140-0170	fxd, mica, 5.6K pf $\pm 5\%$, 300 vdcw	
C62	0170-0079	fxd, my, 0.047 μ f $\pm 20\%$, 50 vdcw	

See introduction to this section

Table 6-1. Reference Designation Index (Cont'd)

Circuit Reference	Ⓢ Stock No.	Description	Note
C63 thru C65	0150-0052	fxd, cer, 0.05 μ f \pm 20%, 400 vdcw	
C66	0140-0159	fxd, mica, 3K pf \pm 2%, 300 vdcw	
C67	0150-0052	fxd, cer, 0.05 μ f \pm 20%, 400 vdcw	
C68	0140-0092	fxd, mica, 240 pf \pm 5%, 500 vdcw	
C69, 70		Not assigned	
C71	0150-0052	fxd, cer, 0.05 μ f \pm 20%, 400 vdcw	
C72 thru C74	0140-0162	fxd, mica, 4.7K pf \pm 10%, 300 vdcw	
C75	0150-0052	fxd, cer, 0.05 μ f \pm 20%, 400 vdcw	
C76 thru C80		Not assigned	
C81	0170-0029	fxd, poly, 0.01 μ f \pm 10%, 50 vdcw	
C82 thru C85	0130-0006	var, cer, 5-20 pf, 500 vdcw	
C86	0130-0001	var, cer, 7-45 pf, 500 vdcw	
C87	0140-0036	fxd, mica, 110 pf \pm 5%, 500 vdcw	
C88	0130-0001	var, cer, 7-45 pf, 500 vdcw	
C89	0140-0036	fxd, mica, 110 pf \pm 5%, 500 vdcw	
C90	0140-0171	fxd, mica, 0.01 μ f \pm 10%, 300 vdcw	
C91	0140-0152	fxd, mica, 1K pf \pm 5%, 300 vdcw	
C92 thru C100		Not assigned	
C101	0150-0052	fxd, cer, 0.05 μ f \pm 20%, 400 vdcw	
C102	0180-0024	fxd, elect, 40 μ f, 450 vdcw	
C103	0150-0052	fxd, cer, 0.05 μ f \pm 20%, 400 vdcw	
CR1, 2		nsr; part of A3 assy	
CR3	1901-0023	Diode, Si	
CR4	G-29G-79	Diode, Si	
CR5 thru CR10		Not assigned	
CR11 thru CR16	1910-0004	Diode, Ge: 1N90	
DS1 thru DS100		Not assigned	
DS101 thru DS104	2140-0012	Lamp, indicator: 6.3V, 0.15 amp, No. 12	
DS105	2140-0012	Lamp, indicator: 6.3V, 0.15 amp, No. 12	

See introduction to this section

Table 6-1. Reference Designation Index (Cont'd)

Circuit Reference	Ⓢ Stock No.	Description	Note
F1 thru F100		Not assigned	
F101	2110-0007	Fuse, cartridge: 1 amp, s-b (for 115V operation)	
	2110-0008	Fuse, cartridge: 1/2 amp, s-b (for 230V operation)	
FL1	411A-27A	Assy, line filter: includes J2	
J1	AC-10C	Binding post, black (cmo) (rmo)	
	AC-54A	Insulator, binding post: black, double hole (cmo) (rmo)	
	AC-54D	Insulator, binding post: black, single hole (cmo) (rmo)	
	G-10G	Binding post, red (cmo) (rmo)	
J2		nsr; part of FL1	
L1	9140-0020	Inductor, fxd: 400 μ h	
L2	9140-0037	Inductor, fxd, 5 mh	
L3	9140-0087	Inductor, var: 7.5-14 mh	
L4	9140-0013	Inductor, var: 600 μ h \pm 5%	
L5	9140-0040	Inductor, fxd: 42 μ h	
M1	G-81C	Meter	
Q1, 2	1850-0062	Transistor: 2N404	
R1 thru R8		Not assigned	
R9	0687-4721	fxd, comp, 4.7K ohms \pm 10%, 1/2 W	
R10		nsr; part of A3 assy	
R11	0687-2261	fxd, comp, 22M \pm 10%, 1/2 W	
R12	0727-0249	fxd, dep c, 667K ohms \pm 1%, 1/2 W	
R13	2100-0044	var, comp, lin, 50K ohms \pm 10%	
R14	0687-1051	fxd, comp, 1M \pm 10%, 1/2 W	
R15	0687-4711	fxd, comp, 470 ohms \pm 10%, 1/2 W	
R16	0687-2261	fxd, comp, 22M \pm 10%, 1/2 W	
R17	0687-4741	fxd, comp, 470K ohms \pm 10%, 1/2 W	

See introduction to this section

Table 6-1. Reference Designation Index (Cont'd)

Circuit Reference	Ⓢ Stock No.	Description	Note
R18	0687-4751	fxd, comp, 4.7M $\pm 10\%$, 1/2 W	
R19	0687-1031	fxd, comp, 10K ohms $\pm 10\%$, 1/2 W	
R20, 21	0687-1051	fxd, comp, 1M $\pm 10\%$, 1/2 W	
R22	0687-1041	fxd, comp, 100K ohms $\pm 10\%$, 1/2 W	
R23	0687-6821	fxd, comp, 6.8K ohms $\pm 10\%$, 1/2 W	
R24	0687-2221	fxd, comp, 2.2K ohms $\pm 10\%$, 1/2 W	
R25	0687-6811	fxd, comp, 680 ohms $\pm 10\%$, 1/2 W	
R26	0687-2211	fxd, comp, 220 ohms $\pm 10\%$, 1/2 W	
R27	0687-1011	fxd, comp, 100 ohms $\pm 10\%$, 1/2 W	
R28, 29		Not assigned	
R30	0687-1051	fxd, comp, 1M $\pm 10\%$, 1/2 W	
R31	0687-4731	fxd, comp, 47K ohms $\pm 10\%$, 1/2 W	
R32	0687-2751	fxd, comp, 2.7M $\pm 10\%$, 1/2 W	
R33	0687-1021	fxd, comp, 1K ohms $\pm 10\%$, 1/2 W	
R34	0687-1041	fxd, comp, 100K ohms $\pm 10\%$, 1/2 W	
R35	0687-8241	fxd, comp, 820K ohms $\pm 10\%$, 1/2 W	
R36, 37		Not assigned	
R38	0687-2261	fxd, comp, 22M $\pm 10\%$, 1/2 W	
R39 thru R43		Not assigned	
R44, 45	0684-4741	fxd, comp, 470K ohms $\pm 10\%$, 1/4 W	
R46	2100-0194	var, comp, lin, 1K ohms $\pm 20\%$, 1/2 W	
R47	0683-1031	fxd, comp, 10K ohms $\pm 10\%$, 1/2 W	
R48	0687-4721	fxd, comp, 4.7K ohms $\pm 10\%$, 1/2 W	
R49, 50		Not assigned	
R51	0727-0158	fxd, dep c, 10.1K ohms $\pm 1\%$, 1/2 W	
R52	0727-0148	fxd, dep c, 7842 ohms $\pm 1\%$, 1/2 W	
R53	2100-0011	var, comp, lin, 5K ohms	
R54	2100-0167	var, comp, lin, 10K ohms $\pm 30\%$, 1/3 W (rmo)	
	2100-0187	var, comp, lin, 10K ohms $\pm 30\%$, 1/3 W (cmo)	

See introduction to this section

Table 6-1. Reference Designation Index (Cont'd)

Circuit Reference	Ⓢ Stock No.	Description	Note
R55	0687-4721	fxd, comp, 4.7K ohms $\pm 10\%$, 1/2 W	
R56 thru R59		Not assigned	
R60	0687-2241	fxd, comp, 220K ohms $\pm 10\%$, 1/2 W	
R61	0687-6801	fxd, comp, 68 ohms $\pm 10\%$, 1/2 W	
R62	0687-1021	fxd, comp, 1K ohms $\pm 10\%$, 1/2 W	
R63	0687-6801	fxd, comp, 68 ohms $\pm 10\%$, 1/2 W	
R64	0690-8231	fxd, comp, 82K ohms $\pm 10\%$, 1 W	
R65	0687-1021	fxd, comp, 1K ohms $\pm 10\%$, 1/2 W	
R66	0687-1011	fxd, comp, 100 ohms $\pm 10\%$, 1/2 W	
R67	0687-6811	fxd, comp, 680 ohms $\pm 10\%$, 1/2 W	
R68 thru R70		Not assigned	
R71	0693-1031	fxd, comp, 10K ohms $\pm 10\%$, 2 W	
R72 thru R99		Not assigned	
R100	0687-1011	fxd, comp, 100 ohms $\pm 10\%$, 1/2 W	
R101	0816-0017	fxd, ww, 6.3K ohms $\pm 10\%$, 10 W	
R102	0687-2241	fxd, comp, 220K ohms $\pm 10\%$, 1/2 W	
R103	2100-0020	var, ww, lin, 50 ohms $\pm 20\%$, 1 W	
S1	411A-19B	Assy, range switch	
S2 thru S100		Not assigned	
S101	3101-0001	Switch, tog: SPST	
S102	3101-0033	Switch, slide: DPDT	
T1 thru T100		Not assigned	
T101	9100-0021	Transformer, power	
V1,2		nsr; part of A1 assy	
V3	1932-0030	Tube, electron: 12AX7	
V4	1933-0007	Tube, electron: 6AU8	
V5,6	G-30B	Photoconductive cell	
V7	1923-0028	Tube, electron: 6CB6A	

See introduction to this section

Table 6-1. Reference Designation Index (Cont'd)

Circuit Reference	Ⓢ Stock No.	Description	Note
V8 thru V100		Not assigned	
V101	1930-0016	Tube, electron: 6X4	
V102, 103	1940-0007	Tube, electron: OB2	
XF101	1400-0084	Fuseholder	
XV1, 2		Not assigned	
XV3	1200-0073	Socket, tube: 9 pin	
XV4	1200-0048	Socket, tube: 9 pin, pc	
XV5, 6		Not assigned	
XV7	1200-0047	Socket, tube: 7 pin, pc	
XV8 thru XV100		Not assigned	
XV101 thru XV103	1200-0009	Socket, tube: 7 pin	
		<u>MISCELLANEOUS</u>	
	G-74C	Knob, black: 3/4"	
	G-74N	Knob, black: 1" bar w/arrow	
	411A-21A	Assy, probe	
	411A-21A-12	Assy, probe cable	
	411A-21E	Assy, BNC probe-tip	
	411A-21G	Accessory probe kit: includes	
	411A-21A-3	Assy, detector cartridge	
	411A-21B	Assy, probe-tip: pen type	
	411A-21C	Assy, VHF probe-tip	
	411A-21D	Assy, type N "T" probe-tip	
	411A-21F	Assy, 100:1 capacitance divider probe-tip	
	411A-21G-1	Box, accessory	
	411A-37A	Rod, modulator light, lucite	
	411A-65C	Assy, etched circuit board (components included)	
	411A-65D	Assy, etched circuit board (components included)	
	411A-65E	Assy, etched circuit board (components included)	
	425A-97A	Assy, chopper: includes B101, DS101 thru DS104	
	1450-0020	Jewel, pilot light	
	8120-0078	Cable, power	

See introduction to this section

Table 6-2. Replaceable Parts

Stock No.	Description #	Mfr.	Mfr. Part No.	TQ	RS		
AC-10C	Binding post, black (cmo) (rmo)	28480	AC-10C	1 2	1		
AC-54A	Insulator, binding post: black double hole (cmo) (rmo)	28480	AC-54A	1 2	0		
AC-54D	Insulator, binding post: black, single hole (cmo) (rmo)	28480	AC-54D	1 2	0		
G-10G	Binding post, red (cmo) (rmo)	28480	G-10G	1 2	1		
G-29G-79	Diode, Si	28480	G-29G-79	1	1		
G-30B	Photoconductive cell	28480	G-30B	2	2		
G-81C	Meter	28480	G-81C	1	1		
411A-19B	Assy, range switch	28480	411A-19B	1	1		
411A-21A-3	Assy, detector cartridge: includes CR1, CR2, R10	28480	411A-21A-3	1	1		
411A-23C	Assy, modulator: includes V1,2	28480	411A-23C	1	1		
411A-27A	Assy, line filter: includes J2	28480	411A-27A	1	1		
412A-23B	Assy, demodulator	28480	412A-23B	1	1		
0130-0001	C, var, cer, 7-45 pf, 500 vdcw	72982	503000-D2PO-33R	2	1		
0130-0006	C, var, cer, 5-20 pf, 500 vdcw	72982	503000-B2PO-28R	4	1		
0140-0036	C, fxd, mica, 110 pf $\pm 5\%$, 500 vdcw	00853	obd#	2	1		
0140-0091	C, fxd, mica, 820 pf $\pm 5\%$, 500 vdcw	72136	CM20E821J	1	1		
0140-0092	C, fxd, mica, 240 pf $\pm 5\%$, 500 vdcw	00853	OR1324E5	1	1		
0140-0152	C, fxd, mica, 1K pf $\pm 5\%$, 300 vdcw	72136	DM16F102J	1	1		
0140-0159	C, fxd, mica, 3K pf $\pm 2\%$, 300 vdcw	72136	DM19F302G	1	1		
0140-0162	C, fxd, mica, 4.7K pf $\pm 10\%$, 300 vdcw	72136	DM20F472K	3	1		
0140-0170	C, fxd, mica, 5.6K pf $\pm 5\%$, 300 vdcw	72136	DM20F562J	1	1		
0140-0171	C, fxd, mica, 0.01 μf $\pm 10\%$, 300 vdcw	72136	DM30F103K	1	1		
0150-0012	C, fxd, cer, 0.01 μf $\pm 20\%$, 1000 vdcw	71590	13C DISC.	3	1		
0150-0024	C, fxd, cer, 0.02 μf + 80%-20%, 600 vdcw	91418	B.02GMV	1	1		
0150-0050	C, fxd, cer, 1K pf, 600 vdcw	84411	type E	1	1		

See introduction to this section

Table 6-2. Replaceable Parts (Cont'd)

Stock No.	Description #	Mfr.	Mfr. Part No.	TQ	RS
0150-0052	C, fxd, cer, 0.05 μ f \pm 20%, 400 vdcw	05729	20X503MC4	11	3
0150-0067	C, fxd, cer, 130 pf \pm 2%, 500 vdcw	95275	CY13C131G-A	1	1
0160-0015	C, fxd, paper, 0.47 μ f \pm 10%, 200 vdcw	56289	109P47492	1	1
0160-0029	C, fxd, paper, 1 μ f \pm 20%, 200 vdcw	82376	MQCS-2-1M	1	1
0170-0029	C, fxd, poly, 0.01 μ f \pm 10%, 50 vdcw	56289	114P1039R5S2	2	1
0170-0030	C, fxd, poly, 0.1 μ f \pm 10%, 50 vdcw	56289	type 114P style T15	1	1
0170-0077	C, fxd, poly, 0.047 μ f \pm 10%, 50 vdcw	56289	114P4739R5T15	1	1
0170-0079	C, fxd, my, 0.047 μ f \pm 20%, 50 vdcw	84411	style 3, type 601PE	1	1
0180-0011	C, fxd, elect, 20 μ f, 450 vdcw	56289	D32550	1	1
0180-0024	C, fxd, elect, 40 μ f, 450 vdcw	56289	D32441	1	1
0180-0033	C, fxd, elect, 50 μ f, 6 vdcw	56289	30D133A1	2	1
0684-4741	R, fxd, comp, 470K ohms \pm 10%, 1/4 W	01121	CB4741	2	1
0687-1011	R, fxd, comp, 100 ohms \pm 10%, 1/2 W	01121	EB1011	3	1
0687-1021	R, fxd, comp, 1K ohms \pm 10%, 1/2 W	01121	EB1021	3	1
0687-1031	R, fxd, comp, 10K ohms \pm 10%, 1/2 W	01121	EB1031	2	1
0687-1041	R, fxd, comp, 100K ohms \pm 10%, 1/2 W	01121	EB1041	2	1
0687-1051	R, fxd, comp, 1M \pm 10%, 1/2 W	01121	EB1051	4	1
0687-2211	R, fxd, comp, 220 ohms \pm 10%, 1/2 W	01121	EB2211	1	1
0687-2221	R, fxd, comp, 2.2K ohms \pm 10%, 1/2 W	01121	EB2221	1	1
0687-2241	R, fxd, comp, 220K ohms \pm 10%, 1/2 W	01121	EB2241	2	1
0687-2261	R, fxd, comp, 22M \pm 10%, 1/2 W	01121	EB2261	3	1
0687-2751	R, fxd, comp, 2.7M \pm 10%, 1/2 W	01121	EB2751	1	1
0687-4711	R, fxd, comp, 470 ohms \pm 10%, 1/2 W	01121	EB4711	1	1
0687-4721	R, fxd, comp, 4.7K ohms \pm 10%, 1/2 W	01121	EB4721	2	1
0687-4731	R, fxd, comp, 47K ohms \pm 10%, 1/2 W	01121	EB4731	1	1
0687-4741	R, fxd, comp, 470K ohms \pm 10%, 1/2 W	01121	EB4741	1	1
0687-4751	R, fxd, comp, 4.7M \pm 10%, 1/2 W	01121	EB4751	1	1
0687-6801	R, fxd, comp, 68 ohms \pm 10%, 1/2 W	01121	EB6801	2	1
0687-6811	R, fxd, comp, 680 ohms \pm 10%, 1/2 W	01121	EB6811	2	1

See introduction to this section

Table 6-2. Replaceable Parts (Cont'd)

Stock No.	Description #	Mfr.	Mfr. Part No.	TQ	RS		
0687-6821	R, fxd, comp, 6.8K ohms $\pm 10\%$, 1/2 W	01121	EB6821	1	1		
0687-8241	R, fxd, comp, 820K ohms $\pm 10\%$, 1/2 W	01121	EB8241	1	1		
0690-8231	R, fxd, comp, 82K ohms $\pm 10\%$, 1 W	01121	GB8231	1	1		
0693-1031	R, fxd, comp, 10K ohms $\pm 10\%$, 2 W	01121	HB1031	1	1		
0727-0148	R, fxd, dep c, 7842 ohms $\pm 1\%$, 1/2 W	19701	DC1/2CR5 obd#	1	1		
0727-0158	R, fxd, dep c, 10.1K ohms $\pm 1\%$, 1/2 W	19701	DC1/2CR5 obd#	1	1		
0727-0249	R, fxd, dep c, 667K ohms $\pm 1\%$, 1/2 W	19701	DC1/2CR5 obd#	1	1		
0816-0017	R, fxd, ww, 6.3K ohms $\pm 10\%$, 10 W	35434	type C-10	1	1		
1200-0009	Socket, tube: 7 pin	91662	316PH-3702	3	1		
1200-0047	Socket, tube: 7 pin, pc	91662	3708-2-4	1	1		
1200-0048	Socket, tube: 9 pin, pc	91662	3908-2-4	1	1		
1200-0073	Socket, tube: 9 pin	95354	PCNJ-237 (BC-AG)	1	1		
1400-0084	Fuseholder	75915	342014	1	1		
1850-0062	Transistor: 2N404	02735	34146	2	2		
1901-0023	Diode, Si	000CC	COD1-159	1	1		
1910-0004	Diode, Ge: 1N90	73293	1N90	6	6		
1923-0028	Tube, electron: 6CB6A	80131	6CB6A	1	1		
1930-0016	Tube, electron: 6X4	80131	6X4	1	1		
1932-0030	Tube, electron: 12AX7	80131	12AX7	1	1		
1933-0007	Tube, electron: 6AU8	80131	6AU8	1	1		
1940-0007	Tube, electron: OB2	80131	OB2	2	2		
2100-0011	R, var, comp, lin, 5K ohms	11237	type 45, obd#	1	1		
2100-0020	R, var, ww, lin, 50 ohms $\pm 20\%$, 1 W	11236	type 112	1	1		
2100-0044	R, var, comp, lin, 50K ohms $\pm 10\%$	01121	JA1NO56S503UA	1	1		
2100-0167	R, var, comp, lin, 10K ohms $\pm 30\%$, 1/3 W (rmo)	11237	type 45, obd#	(1)	1		
2100-0187	R, var, comp, lin, 10K ohms $\pm 30\%$, 1/3 W (cmo)	11237	type 45, obd#	1	1		
2100-0194	R, var, comp, lin, 1K ohms $\pm 20\%$, 1/2 W	11237	type 45, obd#	1	1		
2110-0007	Fuse, cartridge: 1 amp, s-b (for 115V operation)	71400	MDL1	1	10		

See introduction to this section

Table 6-2. Replaceable Parts (Cont'd)

Stock No.	Description #	Mfr.	Mfr. Part No.	TQ	RS
2110-0008	Fuse, cartridge: 1/2 amp, s-b (for 230V operation)	71400	MDL1/2		
2140-0012	Lamp, indicator: 6.3V, 0.15 amp, No. 12	24455	No. 12	1	1
3101-0001	Switch, toggle: SPST	04009	AH&H80994-H	1	1
3101-0033	Switch, slide: DPDT	42190	4633	1	1
9100-0021	Transformer, power	98734	4076	1	1
9140-0013	Inductor, var: 600 μ h \pm 5%	98405	300-600 μ h	1	1
9140-0020	Inductor, fxd: 400 μ h	99848	1400-15-401	1	1
9140-0037	Inductor, fxd: 5 mh	99848	35000-15-502	1	1
9140-0040	Inductor, fxd: 42 μ h	99848	obd#	1	1
9140-0087	Inductor, var: 7.5-14 mh	09250	obd#	1	1
<u>MISCELLANEOUS</u>					
G-74C	Knob, black: 3/4" (cmo) (rmo)	28480	G-74C	1 2	0 0
G-74N	Knob, black: 1" bar w/arrow	28480	G-74N	1	0
411A-21A	Assy, probe	28480	411A-21A	1	1
411A-21A -12	Assy, probe cable	28480	411A-21A-12	1	1
411A-21E	Assy, BNC probe-tip	28480	411A-21E	1	1
411A-21G	Accessory probe kit: includes	28480	411A-21G	1	0
411A-21A -3	Assy, detector cartridge	28480	411A-21A-3	(1)	
411A-21B	Assy, probe-tip: pen type	28480	411A-21B	(1)	
411A-21C	Assy, VHF probe-tip	28480	411A-21C	(1)	
411A-21D	Assy, type N "T" probe-tip	28480	411A-21D	(1)	
411A-21F	Assy, 100:1 capacitance divider probe-tip	28480	411A-21F	(1)	
411A-21G -1	Box, accessory	28480	411A-21G-1	(1)	
411A-37A	Rod, modulator light	28480	411A-37A	2	0
411A-65C	Assy, etched circuit board (components included)	28480	411A-65C	1	0
411A-65D	Assy, etched circuit board (components included)	28480	411A-65D	1	0
411A-65E	Assy, etched circuit board (components included)	28480	411A-65E	1	0
425A-97A	Assy, chopper: includes B101, DS101 thru DS104	28480	425A-97A	1	1
1450-0020	Jewel, pilot light	72765	14L-15	1	1
8120-0078	Cable, power	70903	KH-4147	1	1

See introduction to this section

APPENDIX

CODE LIST OF MANUFACTURERS (Sheet 1 of 2)

The following code numbers are from the Federal Supply Code for Manufacturers Cataloging Handbooks H4-1 (Name to Code) and H4-2 (Code to Name) and their latest supplements. The date of revision and the date of the supplements used appear at the bottom of each page. Alphabetical codes have been arbitrarily assigned to suppliers not appearing in the H4 handbooks.

CODE NO.	MANUFACTURER	ADDRESS	CODE NO.	MANUFACTURER	ADDRESS	CODE NO.	MANUFACTURER	ADDRESS
00334	Humidial Co.	Colton, Calif.	07137	Transistor Electronics Corp.	Minneapolis, Minn.	48620	Precision Thermometer and Inst. Co.	Philadelphia, Pa.
00335	Westrex Corp.	New York, N.Y.	07138	Westinghouse Electric Corp. Electronic Tube Div.	Elmira, N.Y.	49956	Raytheon Company	Lexington, Mass.
00373	Garlock Packing Co., Electronic Products Div.	Camden, N.J.	07261	Avnet Corp.	Los Angeles, Calif.	54294	Shallcross Mfg. Co.	Selma, N.C.
00656	Aerovox Corp.	New Bedford, Mass.	07263	Fairchild Semiconductor Corp.	Mountain View, Calif.	55026	Simpson Electric Co.	Chicago, Ill.
00779	Amp, Inc.	Harrisburg, Pa.	07910	Continental Device Corp.	Hawthorne, Calif.	55933	Sonotone Corp.	Elmsford, N.Y.
00781	Aircraft Radio Corp.	Boonton, N.J.	07933	Rheem Semiconductor Corp.	Mountain View, Calif.	55938	Sorenson & Co., Inc.	So. Norwalk, Conn.
00853	Sangamo Electric Company, Ordill Division (Capacitors)	Marion, Ill.	07980	Boonton Radio Corp.	Boonton, N.J.	56137	Spaulding Fibre Co., Inc.	Tonawanda, N.Y.
00866	Goe Engineering Co.	Los Angeles, Calif.	08145	U.S. Engineering Co.	Los Angeles, Calif.	56289	Sprague Electric Co.	North Adams, Mass.
00891	Carl E. Holmes Corp.	Los Angeles, Calif.	08358	Burgess Battery Co.	Niagara Falls, Ontario, Canada	59446	Telex, Inc.	St. Paul, Minn.
01121	Allen Bradley Co.	Milwaukee, Wis.	08717	Sloan Company	Burbank, Calif.	61775	Union Switch and Signal, Div. of Westinghouse Air Brake Co.	Swissvale, Pa.
01255	Litton Industries, Inc.	Beverly Hills, Calif.	08718	Cannon Electric Co. Phoenix Div.	Phoenix, Ariz.	62119	Universal Electric Co.	Owosso, Mich.
01281	Pacific Semiconductors, Inc.	Culver City, Calif.	08792	CBS Electronics Semiconductor Operations, Div. of C.B.S. Inc.	Lowell, Mass.	64959	Western Electric Co., Inc.	New York, N.Y.
01295	Texas Instruments, Inc. Transistor Products Div.	Dallas, Texas	09026	Babcock Relays, Inc.	Costa Mesa, Calif.	65092	Weston Inst. Div. of Daystrom, Inc.	Newark, N.J.
01349	The Alliance Mfg. Co.	Alliance, Ohio	09134	Texas Capacitor Co.	Houston, Texas	66346	Wollensak Optical Co.	Rochester, N.Y.
01561	Chassi-Trak Corp.	Indianapolis, Ind.	09250	Electro Assemblies, Inc.	Chicago, Ill.	70276	Allen Mfg. Co.	Hartford, Conn.
01589	Pacific Relays, Inc.	Van Nuys, Calif.	09569	Mallory Battery Co. of Canada, Ltd.	Toronto, Ontario, Canada	70309	Allied Control Co., Inc.	New York, N.Y.
01930	Amerock Corp.	Rockford, Ill.	10411	Ti-Tal, Inc.	Berkeley, Calif.	70485	Atlantic India Rubber Works, Inc.	Chicago, Ill.
01961	Pulse Engineering Co.	Santa Clara, Calif.	10646	Carborundum Co.	Niagara Falls, N.Y.	70563	Amperite Co., Inc.	New York, N.Y.
02114	Ferroxcube Corp. of America	Saugerties, N.Y.	11236	CTS of Berne, Inc.	Berne, Ind.	70903	Belden Mfg. Co.	Chicago, Ill.
02286	Cole Mfg. Co.	Palo Alto, Calif.	11237	Chicago Telephone of California, Inc.	So. Pasadena, Calif.	70998	Bird Electronic Corp.	Cleveland, Ohio
02660	Amphenol-Borg Electronics Corp.	Chicago, Ill.	11312	Microwave Electronics Corp.	Palo Alto, Calif.	71002	Birnbach Radio Co.	New York, N.Y.
02735	Radio Corp. of America Semiconductor and Materials Div.	Somerville, N.J.	11711	General Instrument Corporation Semiconductor Division	Newark, N.J.	71041	Boston Gear Works Div. of Murray Co. of Texas	Quincy, Mass.
02771	Vocaline Co. of America, Inc.	Old Saybrook, Conn.	11717	Imperial Electronics, Inc.	Buena Park, Calif.	71218	Bud Radio Inc.	Cleveland, Ohio
02777	Hopkins Engineering Co.	San Fernando, Calif.	11870	Melabs, Inc.	Palo Alto, Calif.	71286	Camloc Fastener Corp.	Paramus, N.J.
03508	G.E. Semiconductor Products Dept.	Syracuse, N.Y.	12697	Clarostat Mfg. Co.	Dover, N.H.	71313	Allen D. Cardwell Electronic Prod. Corp.	Plainville, Conn.
03705	Apex Machine & Tool Co.	Dayton, Ohio	14655	Cornell Duplicator Elec. Corp.	So. Plainfield, N.J.	71400	Bussmann Fuse Div. of McGraw-Edison Co.	St. Louis, Mo.
03797	Eldema Corp.	El Monte, Calif.	15909	The Daven Co.	Livingston, N.J.	71450	CTS Corp.	Elkhart, Ind.
03877	Transitron Electronic Corp.	Wakefield, Mass.	16758	Delco Radio Div. of G. M. Corp.	Kokomo, Ind.	71468	Cannon Electric Co.	Los Angeles, Calif.
03888	Pyrofilm Resistor Co.	Morristown, N.J.	18873	E. I. DuPont and Co., Inc.	Wilmington, Del.	71471	Cinema Engineering Co.	Burbank, Calif.
03954	Air Marine Motors, Inc.	Los Angeles, Calif.	19315	Eclipse Pioneer, Div. of Bendix Aviation Corp.	Teterboro, N.J.	71482	C. P. Clare & Co.	Chicago, Ill.
04009	Arrow, Hart and Hegeman Elect. Co.	Hartford, Conn.	19500	Thomas A. Edison Industries, Div. of McGraw-Edison Co.	West Orange, N.J.	71528	Standard-Thomson Corp., Clifford Mfg. Co. Div.	Waltham, Mass.
04062	Elmenco Products Co.	New York, N.Y.	19701	Electra Manufacturing Co.	Kansas City, Mo.	71590	Centralab Div. of Globe Union Inc.	Milwaukee, Wis.
04222	Hi-Q Division of Aerovox	Myrtle Beach, S.C.	20183	Electronic Tube Corp.	Philadelphia, Pa.	71700	The Cornish Wire Co.	New York, N.Y.
04298	Elgin National Watch Co., Electronics Division	Burbank, Calif.	21520	Fanstel Metallurgical Corp.	No. Chicago, Ill.	71744	Chicago Miniature Lamp Works	Chicago, Ill.
04404	Dymec Division of Hewlett-Packard Co.	Palo Alto, Calif.	21335	The Fafnir Bearing Co.	New Britain, Conn.	71753	A. O. Smith Corp., Crowley Div.	West Orange, N.J.
04651	Sylvania Electric Prods., Inc. Electronic Tube Div.	Mountain View, Calif.	21964	Fed. Telephone and Radio Corp.	Clifton, N.J.	71785	Cinch Mfg. Corp.	Chicago, Ill.
04713	Motorola, Inc., Semiconductor Prod. Div.	Phoenix, Arizona	24446	General Electric Co. G.E., Lamp Division	Schenectady, N.Y.	71984	Dow Corning Corp.	Midland, Mich.
04732	Filtron Co., Inc. Western Division	Culver City, Calif.	24455	General Radio Co.	West Concord, Mass.	72136	Electro Motive Mfg. Co., Inc.	Willimantic, Conn.
04773	Automatic Electric Co.	Northlake, Ill.	26992	Hamilton Watch Co.	Carlstadt, N.J.	72354	John E. Fast & Co.	Chicago, Ill.
04870	P M Motor Co.	Chicago, Ill.	28480	Hewlett-Packard Co.	Palo Alto, Calif.	72619	Dialight Corp.	Brooklyn, N.Y.
05006	Twentieth Century Plastics, Inc.	Los Angeles, Calif.	33173	G.E. Receiving Tube Dept.	Owensboro, Ky.	72656	General Ceramics Corp.	Keasbey, N.J.
05277	Westinghouse Electric Corp., Semi-Conductor Dept.	Youngwood, Pa.	35434	Lectrohm Inc.	Chicago, Ill.	72758	Girard-Hopkins	Oakland, Calif.
05593	Illumintron Engineering Co.	Sunnyvale, Calif.	37942	P. R. Mallory & Co., Inc.	Indianapolis, Ind.	72765	Drake Mfg. Co.	Chicago, Ill.
05624	Barber Colman Co.	Rockford, Ill.	39543	Mechanical Industries Prod. Co.	Akron, Ohio	72825	Hugh H. Eby Inc.	Philadelphia, Pa.
05729	Metropolitan Telecommunications Corp., Metro Cap. Div.	Brooklyn, N.Y.	40920	Miniature Precision Bearings, Inc.	Keene, N.H.	72928	Gudeman Co.	Chicago, Ill.
05783	Stewart Engineering Co.	Santa Cruz, Calif.	42190	Muter Co.	Chicago, Ill.	72982	Erie Resistor Corp.	Erie, Pa.
06004	The Bassick Co.	Bridgeport, Conn.	43990	C. A. Norgren Co.	Englewood, Colo.	73061	Hansen Mfg. Co., Inc.	Princeton, Ind.
06555	Beede Electrical Instrument Co., Inc.	Penacook, N.H.	44655	Ohmite Mfg. Co.	Skokie, Ill.	73138	Hellipot Div. of Beckman Instruments, Inc.	Fullerton, Calif.
06812	Torrington Mfg. Co., West Div.	Van Nuys, Calif.	47904	Polaroid Corp.	Cambridge, Mass.	73293	Hughes Products Division of Hughes Aircraft Co.	Newport Beach, Calif.
07115	Corning Glass Works Electronic Components Dept.	Bradford, Pa.				73445	Amperex Electronic Co., Div. of North American Phillips Co., Inc.	Hicksville, N.Y.
07126	Digitran Co.	Pasadena, Calif.				73506	Bradley Semiconductor Corp.	Hamden, Conn.
						73559	Carling Electric, Inc.	Hartford, Conn.
						73682	George K. Garrett Co., Inc.	Philadelphia, Pa.
						73743	Fischer Special Mfg. Co.	Cincinnati, Ohio
						73793	The General Industries Co.	Elyria, Ohio
						73905	Jennings Radio Mfg. Co.	San Jose, Calif.
						74455	J. H. Winns, and Sons	Winchester, Mass.

00015-19
Revised: 6 December 1961

From: F.S.C. Handbook Supplements
H4-1 Dated October 1961
H4-2 Dated November 1961

APPENDIX

CODE LIST OF MANUFACTURERS (Sheet 2 of 2)

CODE NO.	MANUFACTURER	ADDRESS	CODE NO.	MANUFACTURER	ADDRESS	CODE NO.	MANUFACTURER	ADDRESS
74861	Industrial Condenser Corp.	Chicago, Ill.	82877	Rotron Manufacturing Co., Inc.	Woodstock, N.Y.	95354	Methode Mfg. Co.	Chicago, Ill.
74868	R.F. Products Division of Amphenol-Borg Electronics Corp.	Danbury, Conn.	82893	Vector Electronic Co.	Glendale, Calif.	95987	Weckesser Co.	Chicago, Ill.
74970	E. F. Johnson Co.	Waseca, Minn.	83058	Carr Fastener Co.	Cambridge, Mass.	96067	Huggins Laboratories	Sunnyvale, Calif.
75042	International Resistance Co.	Philadelphia, Pa.	83125	Pyramid Electric Co.	Darlington, S.C.	96095	Hi-Q Division of Aerovox	Olean, N.Y.
75173	Jones, Howard B., Division of Cinch Mfg. Corp.	Chicago, Ill.	83148	Electro Cords Co.	Los Angeles, Calif.	96256	Thordarson-Meissner Div. of Maguire Industries, Inc.	Mt. Carmel, Ill.
75378	James Knights Co.	Sandwich, N.Y.	83186	Victory Engineering Corp.	Union, N.J.	96296	Solar Manufacturing Co.	Los Angeles, Calif.
75382	Kulka Electric Corporation	Mt. Vernon, N.Y.	83298	Bendix Corp., Red Bank Div.	Red Bank, N.J.	96330	Carlton Screw Co.	Chicago, Ill.
75818	Lenz Electric Mfg. Co.	Chicago, Ill.	83330	Smith, Herman H., Inc.	Brooklyn, N.Y.	96341	Microwave Associates, Inc.	Burlington, Mass.
75915	Littelfuse Inc.	Des Plaines, Ill.	83501	Gavitt Wire and Cable Co., Div. of Amerace Corp.	Brookfield, Mass.	96501	Excel Transformer Co.	Oakland, Calif.
76005	Lord Mfg. Co.	Erie, Pa.	83594	Burrhoughs Corp., Electronic Tube Div.	Plainfield, N.J.	97539	Automatic and Precision Mfg. Co.	Yonkers, N.Y.
76210	C. W. Marwedel	San Francisco, Calif.	83777	Model Eng. and Mfg., Inc.	Huntington, Ind.	97966	CBS Electronics, Div. of C.B.S., Inc.	Danvers, Mass.
76433	Micamold Electronic Mfg. Corp.	Brooklyn, N.Y.	83821	Loyd Scruggs Co.	Festus, Mo.	98141	Axel Brothers Inc.	Jamaica, N.Y.
76487	James Millen Mfg. Co., Inc.	Malden, Mass.	84171	Arco Electronics, Inc.	New York, N.Y.	98220	Francis L. Mosley	Pasadena, Calif.
76493	J. W. Miller Co.	Los Angeles, Calif.	84396	A. J. Glesener Co., Inc.	San Francisco, Calif.	98278	Microdot, Inc.	So. Pasadena, Calif.
76530	Monadnock Mills	San Leandro, Calif.	84411	Good All Electric Mfg. Co.	Ogallala, Neb.	98291	Seaelectro Corp.	Mamaroneck, N.Y.
76545	Mueller Electric Co.	Cleveland, Ohio	84970	Sarkes Tarzian, Inc.	Bloomington, Ind.	98405	Carad Corp.	Redwood City, Calif.
76854	Oak Manufacturing Co.	Chicago, Ill.	85454	Boonton Molding Company	Boonton, N.J.	98734	Palo Alto Engineering Co., Inc.	Palo Alto, Calif.
77068	Bendix Pacific Division of Bendix Corp.	No. Hollywood, Calif.	85474	R. M. Bracamonte & Co.	San Francisco, Calif.	98821	North Hills Electric Co.	Mineola, N.Y.
77221	Phaestron Instrument and Electronic Co.	South Pasadena, Calif.	85660	Koiled Kords, Inc.	New Haven, Conn.	98925	Clevite Transistor Prod. Div. of Clevite Corp.	Waltham, Mass.
77342	Potter and Brumfield, Div. of American Machine and Foundry	Princeton, Ind.	85911	Seamless Rubber Co.	Chicago, Ill.	98978	International Electronic Research Corp.	Burbank, Calif.
77630	Radio Condenser Co.	Camden, N.J.	86684	Radio Corp. of America, RCA Electron Tube Div.	Harrison, N.J.	99109	Columbia Technical Corp.	New York, N.Y.
77638	Radio Receptor Co., Inc.	Brooklyn, N.Y.	87216	Philco Corp. (Lansdale Division)	Lansdale, Pa.	99313	Varian Associates	Palo Alto, Calif.
77764	Resistance Products Co.	Harrisburg, Pa.	87473	Western Fibrous Glass Products Co.	San Francisco, Calif.	99515	Marshall Industries, Electron Products Division	Pasadena, Calif.
78283	Signal Indicator Corp.	New York, N.Y.	88140	Cutler-Hammer, Inc.	Lincoln, Ill.	99707	Control Switch Division, Controls Co. of America	El Segundo, Calif.
78471	Tilley Mfg. Co.	San Francisco, Calif.	89473	General Electric Distributing Corp.	Schenectady, N.Y.	99800	Delevan Electronics Corp.	East Aurora, N.Y.
78488	Stackpole Carbon Co.	St. Marys, Pa.	89636	Carter Parts Div. of Economy Baler Co.	Chicago, Ill.	99848	Wilco Corporation	Indianapolis, Ind.
78553	Tinnerman Products, Inc.	Cleveland, Ohio	89665	United Transformer Co.	Chicago, Ill.	99934	Renbrandt, Inc.	Boston, Mass.
78790	Transformer Engineers	Pasadena, Calif.	90179	U.S. Rubber Co., Mechanical Goods Div.	Passaic, N.J.	99942	Hoffman Semiconductor Div. of Hoffman Electronics Corp.	Evanston, Ill.
78947	Ucinite Co.	Newtonville, Mass.	90970	Bearing Engineering Co.	San Francisco, Calif.	99957	Technology Instrument Corp. of Calif.	Newbury Park, Calif.
79142	Veeder Root, Inc.	Hartford, Conn.	91260	Connor Spring Mfg. Co.	San Francisco, Calif.			
79251	Wenco Mfg. Co.	Chicago, Ill.	91418	Radio Materials Co.	Chicago, Ill.			
79727	Continental-Wirt Electronics Corp.	Philadelphia, Pa.	91506	Augat Brothers, Inc.	Attleboro, Mass.			
79963	Zierick Mfg. Corp.	New Rochelle, N.Y.	91637	Dale Electronics, Inc.	Columbus, Nebr.			
80031	Mapco Division of Sessions Clock Co.	Morristown, N.J.	91662	Elco Corp.	Philadelphia, Pa.			
80130	Times Facsimile Corp.	New York, N.Y.	91737	Gremer Mfg. Co., Inc.	Wakefield, Mass.			
80131	Electronic Industries Association Any brand tube meeting EIA standards	Washington, D.C.	91827	K F Development Co.	Redwood City, Calif.			
80207	Unimax Switch, Div. of W. L. Maxson Corp.	Wallingford, Conn.	91921	Minneapolis-Honeywell Regulator Co., Micro-Switch Division	Freeport, Ill.			
80248	Oxford Electric Corp.	Chicago, Ill.	92196	Universal Metal Products, Inc.	Bassett Puenta, Calif.			
80294	Bourns Laboratories, Inc.	Riverside, Calif.	93332	Sylvania Electric Prod. Inc., Semiconductor Div.	Woburn, Mass.			
80411	Acro Div. of Robertshaw Fulton Controls Co.	Columbus 16, Ohio	93369	Robbins and Myers, Inc.	New York, N.Y.			
80486	All Star Products Inc.	Defiance, Ohio	93410	Stevens Mfg. Co., Inc.	Mansfield, Ohio			
80583	Hammerlund Co., Inc.	New York, N.Y.	93983	Insuline-Van Norman Ind., Inc. Electronic Division	Manchester, N.H.			
80640	Stevens, Arnold, Co., Inc.	Boston, Mass.	94144	Raytheon Mfg. Co., Industrial Components Div., Receiving Tube Operation	Quincy, Mass.			
81030	International Instruments, Inc.	New Haven, Conn.	94145	Raytheon Mfg. Co., Semiconductor Div., California Street Plant	Newton, Mass.			
81415	Wilkor Products, Inc.	Cleveland, Ohio	94148	Scientific Radio Products, Inc.	Loveland, Colo.			
81453	Raytheon Mfg. Co., Industrial Components Div., Industr. Tube Operations	Newton, Mass.	94154	Tung-Sol Electric, Inc.	Newark, N.J.			
81483	International Rectifier Corp.	El Segundo, Calif.	94197	Curtiss-Wright Corp., Electronics Div.	East Paterson, N.J.			
81860	Barry Controls, Inc.	Watertown, Mass.	94310	Tru Ohm Prod. Div. of Model Engineering and Mfg. Co.	Chicago, Ill.			
82042	Carter Parts Co.	Skokie, Ill.	94682	Worcester Pressed Aluminum Corp.	Worcester, Mass.			
82142	Jeffers Electronics Division of Spear Carbon Co.	Du Bois, Pa.	95236	Allias Products Corp.	Miami, Fla.			
82170	Allen B. DuMont Labs., Inc.	Clifton, N.J.	95238	Continental Connector Corp.	Woodside, N.Y.			
82209	Maguire Industries, Inc.	Greenwich, Conn.	95263	Lecrafft Mfg. Co., Inc.	New York, N.Y.			
82219	Sylvania Electric Prod. Inc., Electronic Tube Div.	Emporium, Pa.	95264	Leeco Electronics, Inc.	Burbank, Calif.			
82376	Astron Co.	East Newark, N.J.	95265	National Coil Co.	Sheridan, Wyo.			
82389	Switchcraft, Inc.	Chicago, Ill.	95275	Vitramon, Inc.	Bridgeport, Conn.			
82647	Metals and Controls, Inc., Texas Instruments, Inc., Spencer Prods.	Div. of Attleboro, Mass.						
82866	Research Products Corp.	Madison, Wis.						

THE FOLLOWING H-P VENDORS HAVE NO NUMBER ASSIGNED IN THE LATEST SUPPLEMENT TO THE FEDERAL SUPPLY CODE FOR MANUFACTURERS HANDBOOK.

0000F	Malco Tool and Die	Los Angeles, Calif.
0000I	Telefunken (c/o American Elite)	New York, N.Y.
0000L	Winchester Electronics, Inc.	Santa Monica, Calif.
0000M	Western Coil Div. of Automatic Ind., Inc.	Redwood City, Calif.
0000N	Nahm-Bros. Spring Co.	San Leandro, Calif.
0000P	Ty-Car Mfg. Co., Inc.	Holliston, Mass.
0000T	Texas Instruments, Inc. Metals and Controls Div.	Versailles, Ky.
0000U	Tower Mfg. Corp.	Providence, R.I.
0000W	Webster Electronics Co. Inc.	New York, N.Y.
0000X	Spruce Pine Mica Co.	Spruce Pine, N.C.
0000Y	Midland Mfg. Co. Inc.	Kansas City, Kans.
0000Z	Willow Leather Products Corp.	Newark, N.J.
000AA	British Radio Electronics Ltd.	Washington, D.C.
000BB	Precision Instrument Components Co.	Van Nuys, Calif.
000CC	Computer Diode Corp.	Lodi, N.J.
000DD	General Transistor	Los Angeles, Calif.
000EE	A. Williams Manufacturing Co.	San Jose, Calif.
000FF	Carmichael Corrugated Specialties	Richmond, Calif.
000GG	Goshen Die Cutting Service	Goshen, Ind.

From: F.S.C. Handbook Supplements
H4-1 Dated October 1961
H4-2 Dated November 1961

00015-19
Revised: 6 December 1961

hp MANUAL CHANGES

MODEL 411A

RF MILLIVOLTMETER

Manual Serial Prefixed: 131-
Manual Printed: 2/62

To adapt this manual to instruments with other serial prefixes check for errata below, and make changes shown in tables.

Instrument Serial Prefix	Make Manual Changes	Instrument Serial Prefix	Make Manual Changes
117-	1, ERRATA		

CHANGE 1

To change to 230-volt operation, move jumpers as shown in Figure 5-5 to the 230-volt position. See top ac-primary circuit on Power Supply schematic for details.

ERRATA:

Table 1-1, Specifications,
Add TEMPERATURE RANGE: 10° - 40° C.

Under ACCESSORIES AVAILABLE,
Change shunt capacity of 411A-21B Pen Type Probe Tip
to "less than 5 pf".

Table 6-1, 6-2,
A2: Change to assembly, demodulator: includes V5, 6; Ⓢ Stock
No. 411A-23D.

8/27/62 - BD

7/25/62 - BD

3/13/62 - BD

hp MANUAL CHANGES

MODEL 411A

RF MILLIVOLTMETER

Manual Serial Prefixed: 131-

Manual Printed: 2/62

To adapt this manual to instruments with other serial prefixes check for errata below, and make changes shown in tables.

Instrument Serial Prefix	Make Manual Changes	Instrument Serial Prefix	Make Manual Changes
131-	ERRATA	131-00816 & above	1, ERRATA

ERRATA:

Table 1-1, Specifications,

Add TEMPERATURE RANGE: 10° - 40° C.

Under Probe Tip Furnished: Change shunt capacity to less than 5 pf.

Under Accessories Available: 411A-21C VHF change to read, "Probe tip shunt capacity to less than 5 pf."

Under Accessories Available: 411A-21F 100:1 change to read, "Capacity Divider Probe Tip shunt capacity to less than 2 pf."

Table 6-1, 6-2,

A2: Change to assembly, demodulator: includes V5, 6; Ⓢ Stock No. 411A-23D

Paragraph 4-21,

Add to end of paragraph: When Q1 is inoperative (when needle on meter is to left of zero) loop is opened and the meter needle reaction is slow.

Paragraph 5-35,

Add to the beginning of paragraph: On the most sensitive range only, there is a beat on the meter at 1/6th of the line frequency. This adjustment made to minimize this beat.

Figure 5-6,

Use bottom T101 primary circuit.

ERRATA

Table 6-2, Replaceable Parts,

Change 411A-21A3 to 5082-5004

CHANGE #1

Add C92: Capacitor, T1, 1.5 pf, ±20%, 500 vdcw; Ⓢ Stock No. 0150-0011.

Connect from pin 1 V3A to pin 4 V3A.

5/9/63 (PC-8011) L

Supplement A for
411A-900