

## Startup Guide

# Keysight M9380A PXIe Vector Signal Generator 1 MHz to 3 GHz or 6 GHz



Notice: This document contains references to Agilent. Please note that Agilent's Test and Measurement business has become Keysight Technologies. For more information, go to [www.keysight.com](http://www.keysight.com).

## Notices

© Keysight Technologies, Inc. 2013, 2014

No part of this manual may be reproduced in any form or by any means (including electronic storage and retrieval or translation into a foreign language) without prior agreement and written consent from Keysight

Technologies, Inc. as governed by United States and international copyright laws.

Manual Part Number  
M9380-90001

Edition

October 2014. Build 2014.10.25.1441

### Sales and Technical Support

For product specific information and support, and to obtain the latest software and documentation, refer to

[www.keysight.com/find/pxi-mimo](http://www.keysight.com/find/pxi-mimo).

Worldwide contact information for repair and service can be found at

[www.keysight.com/find/assist](http://www.keysight.com/find/assist).

Information on preventing damage to your Keysight equipment can be found at

[www.keysight.com/find/tips](http://www.keysight.com/find/tips).

### Regulatory Compliance

This product has been designed and tested in accordance with accepted industry standards, and has been supplied in a safe condition. To review the Declaration of Conformity, go to <http://regulations.corporate.keysight.com/DoC/search.htm>.

### Warranty

The material contained in this document is provided “as is,” and is subject to being

changed, without notice, in future editions. Further, to the maximum extent permitted by applicable law, Keysight disclaims all warranties, either express or implied, with regard to this manual and any information contained herein, including but not limited to the implied warranties of merchantability and fitness for a particular purpose. Keysight shall not be liable for errors or for incidental or consequential damages in connection with the furnishing, use, or performance of this document or of any information contained herein. Should Keysight and the user have a separate written agreement with warranty terms covering the material in this document that conflict with these terms, the warranty terms in the separate agreement shall control. Keysight Technologies does not warrant third-party system-level (combination of chassis, controllers, modules, etc.) performance, safety, or regulatory compliance, unless specifically stated.

### Technology Licenses

The hardware and/or software described in this document are furnished under a license and may be used or copied only in accordance with the terms of such license.

### Restricted Rights Legend

If software is for use in the performance of a U.S. Government prime contract or sub-contract, Software is delivered and licensed as “Commercial computer software” as defined in DFAR 252.227-7014 (June 1995), or as a “commercial item” as defined in FAR 2.101(a) or as “Restricted computer software” as defined in FAR 52.227-19 (June 1987) or any equivalent agency regulation or contract clause. Use, duplication or disclosure of Software is subject to Keysight Technologies’ standard commercial license terms, and non-DOD Departments and Agencies of the U.S.

Government will receive no greater than Restricted Rights as defined in FAR 52.227-19 (c)(1-2) (June 1987). U.S. Government users will receive no greater than Limited Rights as defined in FAR 52.227-14 (June 1987) or DFAR 252.227-7015 (b)(2) (November 1995), as applicable in any technical data.

### Safety Notices

The following safety precautions should be observed before using this product and any associated instrumentation.

This product is intended for use by qualified personnel who recognize shock hazards and are familiar with the safety precautions required to avoid possible injury. Read and follow all installation, operation, and maintenance information carefully before using the product.

#### WARNING

If this product is not used as specified, the protection provided by the equipment could be impaired. This product must be used in a normal condition (in which all means for protection are intact) only.

The types of product users are:

- **Responsible body** is the individual or group responsible for the use and maintenance of equipment, for ensuring that the equipment is operated within its specifications and operating limits, and for ensuring operators are adequately trained.
- **Operators** use the product for its intended function. They must be trained in electrical safety procedures and proper use of the instrument. They must be protected from electric shock and contact with hazardous live circuits.
- **Maintenance personnel** perform routine procedures on the product to keep it operating properly (for example, setting the line voltage or replacing consumable materials).

Maintenance procedures are described in the user documentation. The procedures explicitly state if the operator may perform them. Otherwise, they should be performed only by service personnel.

- **Service personnel** are trained to work on live circuits, perform safe installations, and repair products. Only properly trained service personnel may perform installation and service procedures.

### **WARNING**

Operator is responsible to maintain safe operating conditions. To ensure safe operating conditions, modules should not be operated beyond the full temperature range specified in the Environmental and physical specification. Exceeding safe operating conditions can result in shorter lifespans, improper module performance and user safety issues. When the modules are in use and operation within the specified full temperature range is not maintained, module surface temperatures may exceed safe handling conditions which can cause discomfort or burns if touched. In the event of a module exceeding the full temperature range, always allow the module to cool before touching or removing modules from the chassis.

Keysight products are designed for use with electrical signals that are rated Measurement Category I and Measurement Category II, as described in the International Electrotechnical Commission (IEC) Standard IEC 60664. Most measurement, control, and data I/O signals are Measurement Category I and must not be directly connected to mains voltage or to voltage sources with high transient over-voltages. Measurement Category II connections

require protection for high transient over-voltages often associated with local AC mains connections. Assume all measurement, control, and data I/O connections are for connection to Category I sources unless otherwise marked or described in the user documentation.

Exercise extreme caution when a shock hazard is present. Lethal voltage may be present on cable connector jacks or test fixtures. The American National Standards Institute (ANSI) states that a shock hazard exists when voltage levels greater than 30V RMS, 42.4V peak, or 60VDC are present. A good safety practice is to expect that hazardous voltage is present in any unknown circuit before measuring.

Operators of this product must be protected from electric shock at all times. The responsible body must ensure that operators are prevented access and/or insulated from every connection point. In some cases, connections must be exposed to potential human contact. Product operators in these circumstances must be trained to protect themselves from the risk of electric shock. If the circuit is capable of operating at or above 1000V, no conductive part of the circuit may be exposed.

Do not connect switching cards directly to unlimited power circuits. They are intended to be used with impedance-limited sources. NEVER connect switching cards directly to AC mains. When connecting sources to switching cards, install protective devices to limit fault current and voltage to the card.

Before operating an instrument, ensure that the line cord is connected to a properly-grounded power receptacle. Inspect the connecting cables, test leads, and jumpers for possible wear, cracks, or breaks before each use.

When installing equipment where access to the main power cord is restricted, such as rack mounting, a separate main input power disconnect device must be provided in close

proximity to the equipment and within easy reach of the operator.

For maximum safety, do not touch the product, test cables, or any other instruments while power is applied to the circuit under test. ALWAYS remove power from the entire test system and discharge any capacitors before: connecting or disconnecting cables or jumpers, installing or removing switching cards, or making internal changes, such as installing or removing jumpers.

Do not touch any object that could provide a current path to the common side of the circuit under test or power line (earth) ground. Always make measurements with dry hands while standing on a dry, insulated surface capable of withstanding the voltage being measured.

The instrument and accessories must be used in accordance with its specifications and operating instructions, or the safety of the equipment may be impaired.

Do not exceed the maximum signal levels of the instruments and accessories, as defined in the specifications and operating information, and as shown on the instrument or test fixture panels, or switching card.

When fuses are used in a product, replace with the same type and rating for continued protection against fire hazard.

Chassis connections must only be used as shield connections for measuring circuits, NOT as safety earth ground connections.

If you are using a test fixture, keep the lid closed while power is applied to the device under test. Safe operation requires the use of a lid interlock. **CAUTION**

A **CAUTION** notice denotes a hazard. It calls attention to an operating procedure, practice, or the like that, if not correctly performed or adhered to, could result in damage to the product or loss of important data. Do not

proceed beyond a **CAUTION** notice until the indicated conditions are fully understood and met.

### WARNING

A **WARNING** notice denotes a hazard. It calls attention to an operating procedure, practice, or the like that, if not correctly performed or adhered to, could result in personal injury or death. Do not proceed beyond a **WARNING** notice until the indicated conditions are fully understood and met.

Instrumentation and accessories shall not be connected to humans.

Before performing any maintenance, disconnect the line cord and all test cables.

To maintain protection from electric shock and fire, replacement components in mains circuits – including the power transformer, test leads, and input jacks – must be purchased from Keysight. Standard fuses with applicable national safety approvals may be used if the rating and type are the same. Other components that are not safety-related may be purchased from other suppliers as long as they are equivalent to the original component (note that selected parts should be purchased only through Keysight to maintain accuracy and functionality of the product). If you are unsure about the applicability of a replacement component, call an Keysight office for information.

### WARNING

No operator serviceable parts inside. Refer servicing to qualified personnel. To prevent electrical shock do not remove covers. For continued protection against fire hazard, replace fuse with same type and rating.

### PRODUCT MARKINGS:



The CE mark is a registered trademark of the European Community.



Australian Communication and Media Authority mark to indicate regulatory compliance as a registered supplier.



This symbol indicates product compliance with the Canadian Interference-Causing Equipment Standard (ICES-001). It also identifies the product is an Industrial Scientific and Medical Group 1 Class A product (CISPR 11, Clause 4).



South Korean Class A EMC Declaration. This equipment is Class A suitable for professional use and is for use in electromagnetic environments outside of the home. A급 기기 (업무용 방송통신기자재) 이 기기는 업무용 (A급) 전자파적합기기로서 판매자 또는 사용자는 이 점을 주의하시기 바라며, 가정외의 지역에서 사용하는 것을 목적으로 합니다.



This symbol indicates separate collection for electrical and electronic equipment, mandated under EU law as of August 13, 2005. All electric and electronic equipment are required to be separated from normal waste for disposal (Reference WEEE Directive, 2002/96/EC).



This symbol indicates the instrument is sensitive to electrostatic discharge (ESD). ESD can damage the highly sensitive components in your instrument. ESD damage is most likely to occur as the module is being installed or when cables are connected or disconnected. Protect the circuits from ESD damage by wearing a grounding strap that provides a high resistance path to ground. Alternatively, ground yourself to discharge any built-up static charge by touching the outer shell of any grounded instrument chassis before touching the port connectors.



This symbol on an instrument means caution, risk of danger. You should refer to the operating instructions located in the user documentation in all cases where the symbol is marked on the instrument.



This symbol indicates the time period during which no hazardous or toxic substance elements are expected to leak or deteriorate during normal use. Forty years is the expected useful life of the product.

### CLEANING PRECAUTIONS:

### WARNING

To prevent electrical shock, disconnect the Keysight Technologies instrument from mains before cleaning. Use a dry cloth or one slightly dampened with water to clean the external case parts. Do not attempt to clean internally. To clean the connectors, use alcohol in a well-ventilated area. Allow all residual alcohol moisture to evaporate, and the fumes to dissipate prior to energizing the instrument.

# Table of Contents

---

Documentation Map .....	7
<b>M9380A Introduction .....</b>	<b>9</b>
Related Documentation .....	9
Follow the Startup Sequence .....	9
<b>Step 1: Unpack and Inspect the Modules .....</b>	<b>11</b>
ESD .....	11
Inspect for Damage .....	11
Return an Instrument for Service .....	11
<b>Step 2: Verify M9380A Shipment Contents .....</b>	<b>12</b>
<b>Items included in your Keysight M9380A PXIe CW Source Shipment .....</b>	<b>12</b>
M9380A Model – Option List .....	13
<b>Step 3: Install the Software .....</b>	<b>15</b>
Power up the Controller .....	15
Software Installation Overview .....	16
<b>Software Installation Procedure .....</b>	<b>16</b>
<b>Step 4: Install the Modules .....</b>	<b>17</b>
Recommended best practices to ensure proper and safe module operating con- ditions .....	17
Module Installation Process Overview .....	18
M9380A Instrument Connections .....	20
Sharing the M9300A Frequency Reference .....	21
M9300A PXIe Frequency Reference Front Panel Features .....	24
M9301A PXIe Synthesizer Front Panel Features .....	25
M9310A PXIe Source Output Front Panel Features .....	26
<b>M9380A Block Diagram .....</b>	<b>27</b>
M9380A Block Diagram Reference Table for M9300A .....	27
M9380A Block Diagram Reference Table for M9301A .....	28
M9380A Block Diagram Reference Table for M9310A .....	28
<b>Step 5: Verify Operation of the Keysight M9380A PXIe CW Source .....</b>	<b>30</b>
<b>Step 6: Installation is Complete .....</b>	<b>31</b>
API Overview .....	31
<b>M9380A Specifications .....</b>	<b>32</b>
<b>M9380A Troubleshooting .....</b>	<b>33</b>
Communications .....	33
Status LED States .....	34
<b>M9380A Soft Front Panel Self Tests .....</b>	<b>34</b>
M9300A PXIe Frequency Reference Troubleshooting .....	35
M9301A PXIe Synthesizer Troubleshooting .....	36
M9310A PXIe Source Output Troubleshooting .....	39



# Documentation Map

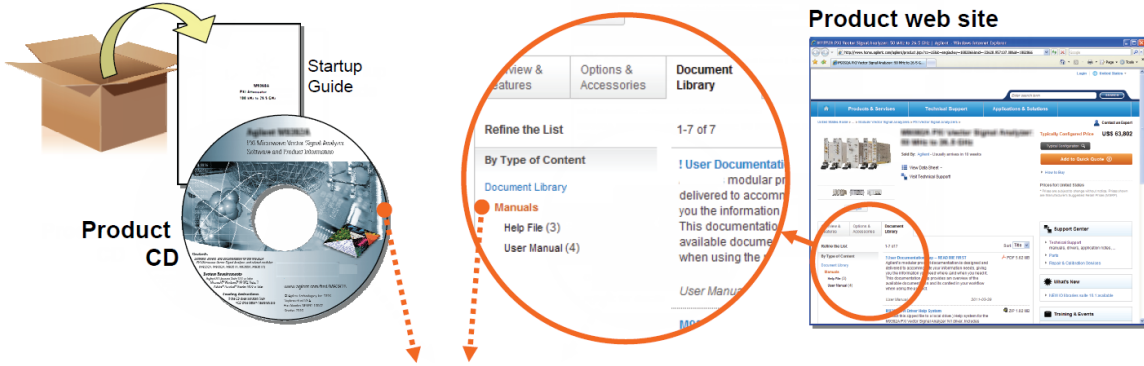

**Access to all DOCUMENTATION noted below**

**Startup Guide**



- Unpack product
- Verify shipment
- Install software
- Install & connect hardware
- Verify operation
- Troubleshooting

**Data Sheet/Specs Guide**



- Technical specifications

**Programming Guide**



- Tutorials
- Code examples
- Measurement examples
- Programming tips

**Soft Front Panel (SFP) user interface**

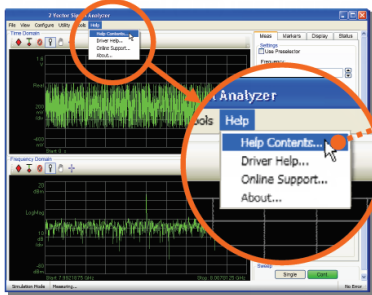

**SFP help system**

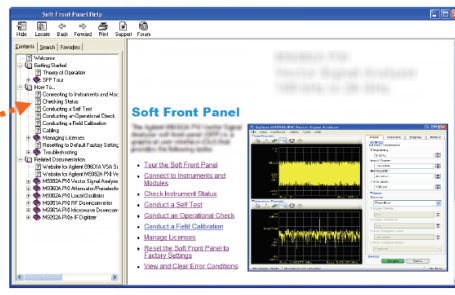

- Theory of operation
- Block diagram
- Configuration
- Self test
- Operational check
- Troubleshooting
- Measurements (limited)
- Field calibration

**Visual Studio**

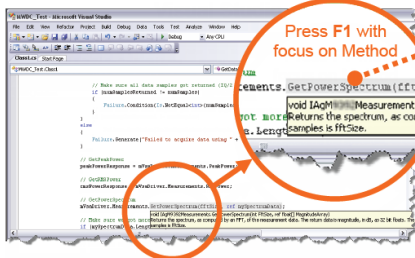

Press F1 with focus on Method

**IVI Driver help system**



- IVI-COM and IVI-C driver programmer's reference
- Sample programs

**LabVIEW**

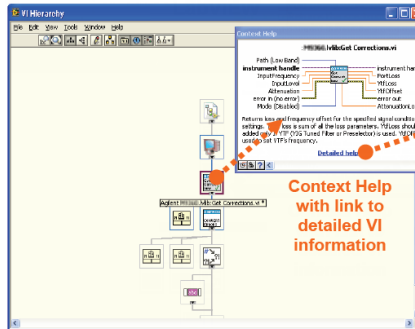

Context Help with link to detailed VI information

**LabVIEW Driver help system**

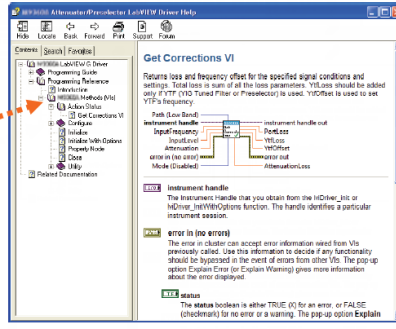

- LabVIEW driver programmer's reference
- Sample programs



## M9380A Introduction

The scope of this Startup Guide is to detail the processes of receiving and installing the software, modules and cables that comprise the Keysight M9380A PXIe CW Source. Troubleshooting is included to assist you in determining and specifying any failures. If you have any questions after reviewing this information, please contact your local Keysight Technologies Inc. representative or contact us through our website at [www.keysight.com/find/M9380A](http://www.keysight.com/find/M9380A).

## Related Documentation

This Startup Guide and the documentation listed below are on the CD and at [www.keysight.com/find/M9380A](http://www.keysight.com/find/M9380A) (go to **Document Library** > **Manuals**).

- M9380A Soft Front Panel help system
- M9380A device driver API help systems (IVI-C/IVI-COM and LabVIEW G)
- M9380A specifications (Data Sheet)

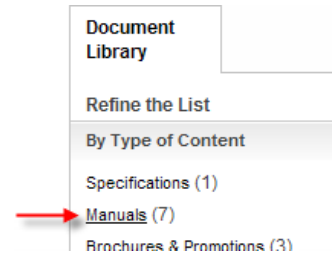

## Follow the Startup Sequence

**WARNING** Closely follow the startup process flow in this document. Deviating from the sequence can cause unpredictable system behavior, damage your system, and may cause personal injury.

### Step 1: Unpack and Inspect



### Step 2: Verify Shipment



### Step 3: Install Drivers and Software

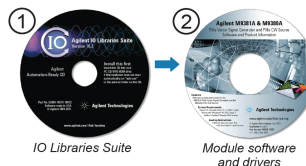

### Step 4: Install Modules

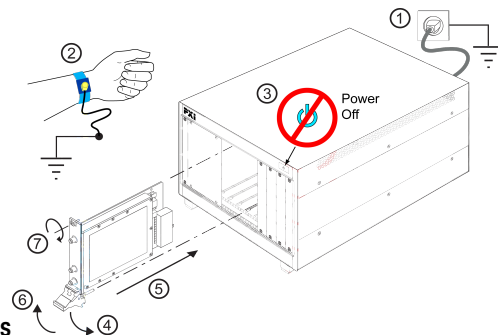

 **Step 5: Verify Operation with the Soft Front Panel (SFP)**

 **Step 6: INSTALLATION COMPLETE.**

**Proceed to program your product through the API.**

## Step 1: Unpack and Inspect the Modules

**CAUTION** The modules are shipped in materials which prevent damage from static. The modules should only be removed from the packaging in an anti-static area ensuring that correct anti-static precautions are taken. Store all modules in anti-static envelopes when not in use.

### ESD

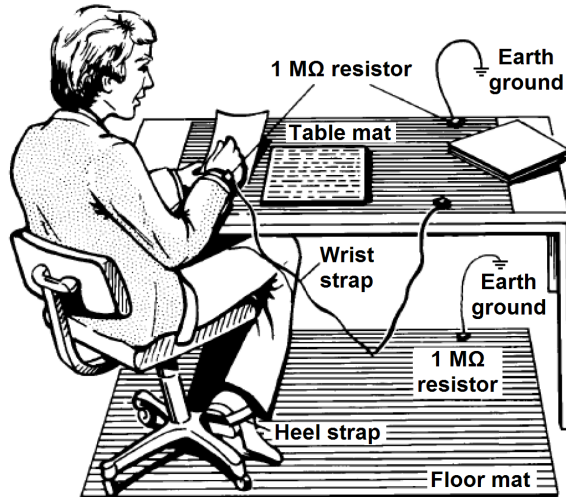

Electrostatic discharge (ESD) can damage or destroy electronic components. Use a static-safe work station to perform all work on electronic assemblies. The figure (left) shows a static-safe work station using two types of ESD protection: conductive table-mat and wrist-strap combination, and conductive floor-mat and heel-strap combination. Both types, when used together, provide a significant level of ESD protection. Of the two, only the table-mat and wrist-strap combination provides adequate ESD protection when used alone. To ensure user safety, the static-safe accessories must provide at least 1 MΩ of isolation from ground.

**WARNING** DO NOT use these techniques for a static-safe work station when working on circuitry with a voltage potential greater than 500 volts.

### Inspect for Damage

After unpacking an instrument, inspect it for any shipping damage. Report any damage to the shipping agent immediately, as such damage is not covered by the warranty (see warranty information at beginning of this document).

**CAUTION** To avoid damage when handling a module, do not touch exposed connector pins.

**NOTE** See [www.keysight.com/find/tips](http://www.keysight.com/find/tips) for information on preventing damage to your keysight equipment.

### Return an Instrument for Service

Should it become necessary to return an instrument for repair or service, follow the steps below:

**NOTE** It is recommended that you return all modules and cables for repair and calibration. If your Keysight M9300A PXle Frequency Reference is operating properly, you need not send it in with the other modules because

## Step 2: Verify M9380A Shipment Contents

your instrument may be repaired and calibrated without your M9300A. Doing so, however, will effect your calibration schedule, since repairs are followed by calibration. The Calibration Due Date for your M9300A will not match the date of your other modules.

1. Review the warranty information shipped with your product.
2. Contact Keysight to obtain a Return Material Authorization (RMA) and return address. For assistance finding Keysight contact information, go to [www.keysight.com/find/assist](http://www.keysight.com/find/assist).
3. Write the following information on a tag and attach it to the malfunctioning equipment:
  - Name and address of owner. A P.O. box is not acceptable as a return address.
  - Module serial number(s). The serial number label is located on the side panel of the module. The serial number can also be read from the Soft Front Panel interface – after the hardware is installed.
  - Description of failure or service required.
4. Pack the instrument in its original packaging. Include all cables. If the original packaging material is not available, use anti-static bubble wrap or packing peanuts and place the instrument in a sealed container and mark the container “FRAGILE”.
5. On the shipping label, write ATTENTION REPAIR DEPARTMENT and the RMA number.

**NOTE** In your correspondence, refer to the modules by serial number and the instrument by model number.

## Step 2: Verify M9380A Shipment Contents

The Keysight M9380A PXIe CW Source is a collection of modules, housed in a PXIe chassis. The minimum CW Source consists of the software, chassis, an Keysight M9301A PXIe Synthesizer, an Keysight M9310A PXIe Source Output and an Keysight M9300A PXIe Frequency Reference. The M9300A may be used in this and other configurations. You may configure the Keysight M9381A PXIe Vector Signal Generator in the same chassis and also use the same M9300A.

### Items included in your Keysight M9380A PXIe CW Source Shipment

Qty	Part Number	Description
1	M9300-10002	Software and Product Information CD, contains: Soft Front Panels, drivers, and all printed documentation in PDF format
1	E2094-60003	Keysight IO Libraries Suite CD
1	M9380-90001	Keysight M9380A PXIe CW Source Startup Guide in hard copy
1	5023-1450	Wrench, socket, extension, 5/16 inch, SMA
1	5002-3361	SMB/MMCX Cable Removal Tool
1	5972-3335	PXI Modular Product Startup Guide Reference

Qty	Part Number	Description
1	9320-6691	China ROHS Addendum for Signal Generator
1	5962-0476	Certificate of Calibration
1	5959-4660	Recommended Due Date for Adjustment/Calibration
1 *	M9300A	(Optional) Keysight M9300A PXIe Frequency Reference
1	M9301A	Keysight M9301A PXIe Synthesizer
1	M9310A	Keysight M9310A PXIe Source Output
3	1810-0118	SMA (m) straight, 50 $\Omega$ termination. Attached to the M9301A RF/LO ports.
1	8121-2063	Cable, coaxial, BNC/male-SMB/female 1200 mm
2	8120-5091	Cable, coaxial, SMB-SMB (120 mm)
1	W1312-20237	Cable, semi-rigid, (SMA-SMA)
1	1250-2316	Adaptor, coaxial, straight, SMA (f) to SMA (m)

\* The Keysight M9300A PXIe Frequency Reference is required to configure an Keysight M9380A PXIe CW Source. It is an option to the M9380A because it may be ordered in, and shared by, the M9381A instrument.

**NOTE**

All of the files contained on the CDs are available for downloading at the Keysight website at <http://www.keysight.com/find/M9380A>.

## M9380A Model – Option List

The following table lists the available options for the Model Keysight M9380A PXIe CW Source.

### Model – Option List for the Keysight M9380A PXIe CW Source

M9380A	Description
M9380A	PXIe C W Source: 1 MHz to 3 GHz or 6 GHz
M9380A-F03	Frequency Range, 1 MHz to 3 GHz
M9380A-F06	Frequency Range: 1 MHz to 6 GHz
M9380A-1EA	High Output Power
*M9380A-300	Keysight M9300A PXIe Frequency Reference: 10 MHz and 100 MHz
M9380A-UK6	Commercial calibration certificate with test data

\* The Keysight M9300A PXIe Frequency Reference is required to configure an Keysight M9380A PXIe CW Source. It is an option to the M9380A because it may be ordered in, and shared by, the M9381A instrument.

Step 2: Verify M9380A Shipment Contents

## Step 3: Install the Software

### System Requirements

Topic	Windows 7 Requirements
Operating system	Windows 7 (32 bit and 64 bit), WES7
Processor speed	1 GHz 32-bit (x86), 1 GHz 64-bit (x64), no support for Itanium64
Available memory	4 GB minimum (8 GB recommended for 64-bit operating systems) <sup>2</sup>
Available disk space	1.5 GB available hard disk space, includes: <ul style="list-style-type: none"> <li>• 1 GB available for Microsoft .NET Framework 3.5 SP1</li> <li>• 100 MB for Keysight IO Libraries Suite</li> </ul>
Video	Support for DirectX 9 graphics with 128 MB graphics memory recommended (Super VGA graphics is supported)
Browser	Microsoft Internet Explorer 7.0 or greater

<sup>1</sup> This is the required disk space for installation. Typically, less disk space is required for operation than is required for installation.

<sup>2</sup> .NET Framework Runtime Components are installed by default with Windows 7 and Vista. Therefore, you may not need this amount of disk space.

### Hardware Requirements

Topic	Requirements
Chassis	PXIe or PXI-H chassis slot
Controllers	A PXI or PXI Express embedded controller or remote controller (external PC connected to the chassis by a PCI-to-PXI interface) is required.
Embedded controller	Keysight <b>M9036A</b> or <b>M9307A</b> or an embedded controller that meets the following requirements: <ul style="list-style-type: none"> <li>• PXIe system controller (PXI-1 embedded controllers are not compatible)</li> <li>• Utilize a 2x8, or 4x4 PXIe system slot link configuration.</li> <li>• Run one of the operating systems listed in System Requirements (above).</li> </ul>
Remote controller	(for Keysight M9018A chassis use only) A PC running one of the operating systems listed in System Requirements above and a Keysight M9021A Cable Interface x8 with one of the following PC interface options: <ul style="list-style-type: none"> <li>• Keysight <b>M9045B</b> PCIe ExpressCard Adaptor x1, with cable (for a laptop PC)</li> <li>• Keysight <b>M9048A</b> PCIe Desktop Adaptor x8, with cable (for desktop PCs)</li> </ul>

### Power up the Controller

**CAUTION** If you are using a remote controller and you have installed the interface cable, you must power up the chassis BEFORE you power up the PC. When you power down your chassis, Shut Down the PC BEFORE you power down the chassis.

If you are using an embedded controller, complete the following steps:

### Step 3: Install the Software

1. Install the embedded controller module into the compatible chassis. The Keysight M9036A PXIe Embedded Controller and Keysight M9018A PXIe Chassis are recommended. Please refer to the embedded controller and chassis documentation for further details.
2. Connect peripherals (mouse, keyboard, monitor).
3. Power up the chassis.

## Software Installation Overview

This installation includes the following:

- Keysight IO Libraries Suite (IOLS), which includes the Keysight Connection Expert. This software is included with your shipment (CD part number E2094-60003), and is also available at [www.keysight.com/find/iosuite](http://www.keysight.com/find/iosuite). This software must be installed first.

**NOTE** Version 16.3.16603.3 (or newer) of the Keysight IO Libraries Suite is required.

- Instrument software, which includes the soft front panel (SFP), device drivers (IVI-C, IVI-COM, and LabVIEW G) and documentation for the M9380A PXIe CW Source. This software is included with your shipment (CD part number M9300-10002) and is also available at [www.keysight.com/find/M9380A](http://www.keysight.com/find/M9380A).

### Software Installation Procedure

1. Install the Keysight IO Libraries Suite from the Keysight IO Libraries Suite CD (E2094-60003) provided in your shipment kit. Follow the installer prompts to install the IO libraries.
2. Install the M9380A product software:
  - a. Using the Keysight PXIe VSA & VSG Software and Product Information CD (M9300-10002), launch the installer.
  - b. Follow the installer prompts. Choose a "Complete" installation to install all software and documentation, or a "Custom" installation to select from a listing of modules and other features.

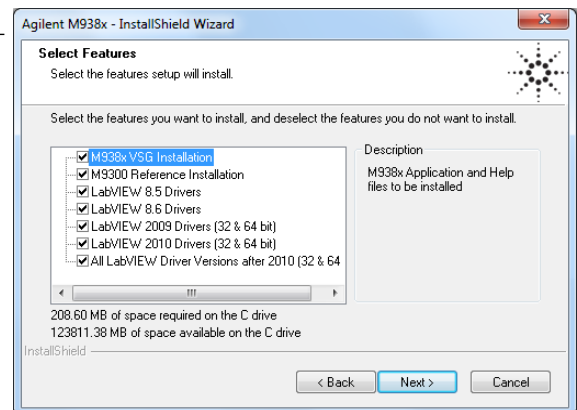

3. Complete the installation

**Embedded controller M9036A, M9037A):**

- a. Select "Yes, I want to restart my computer now."

**Remote controller:**

**(Follow these steps in order, or else instrument**



This is the default selection.

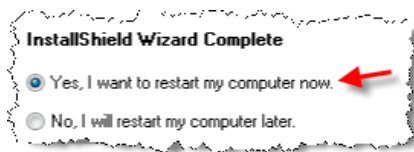

- b. Click on **Finish**.
- c. Wait for the system to restart.

damage may result.)



- b. Click on **Finish**.
- c. Shut down the remote controller PC. Use **Start > Shut down**.
- d. Power down the chassis.
- e. Power up the chassis.
- f. Power up the remote controller PC.

## Step 4: Install the Modules

### CAUTION

PXI hardware does not support "hot-swap" (changing modules while power is applied to the chassis) capabilities. Before installing or removing a module to/from the chassis, power off the chassis to prevent damage to the module.

### NOTE

These modules can be used in a chassis with PXIe or PXI-H chassis slots.

## Recommended best practices to ensure proper and safe module operating conditions

- Ensure proper chassis air flow is maintained
- Select a chassis that provides thermal protection if fans become inoperable or forced air cooling is obstructed
- Use slot blockers (Keysight model [Y1212A](#), 5 per kit) and EMC filler panels in empty module slots to ensure proper operating temperatures. Keysight chassis [Keysight M9018A chassis](#) and slot blockers optimize module temperature performance and reliability of test.
- Set chassis fans to high or auto. Do not disable fans.
- Position chassis to allow plenty of space around chassis air intake and fan exhaust.
- At environment temperatures above 45 °C, set chassis fan speed to high.

## Step 4: Install the Modules

### M9018A Chassis Air Flow



The M9018A has multiple air intakes. They are located at the lower sides, lower front, and bottom of the chassis.

### Module Installation Process Overview

7<sup>H</sup>  
7

The modules can be installed in any PXIe or hybrid PXI slot marked with a peripheral slot compatibility image (solid black circle for PXIe, or solid black circle with the letter "H" for hybrid).

1. Make sure that the line cord is plugged in to establish earth ground and that the chassis power switch is **Off**.
2. If the chassis has multiple fan speed settings, ensure that the fan switch is set to **AUTO** and the inhibit switch is set to **DEF**.



3. Position the chassis to provide ample space between the chassis fan intake and exhaust vents. Blockage by walls or obstructions affects the air flow needed for cooling. (Refer to the chassis documentation for more information about cooling).
4. Before inserting a module into the chassis, back the mounting screws out to ensure that there is no interference between the screws and the mounting rails.
5. See "[M9380A Instrument Connections](#)" on page 20 for positioning the M9380A modules. Install the left-most module first and then proceed installing modules from left to right.
6. Holding the module by the injector/ejector handle, slide it into an available PXI (or hybrid) slot, as shown in the following figure.

- a. Install the module into the slot of the chassis by placing the module card edges into the front module guides (top and bottom).
- b. Slide the module to the rear of the chassis and ensure that the injector/ejector handle is pushed down in the unlatched (downward) position.
- c. Slide the module completely into the chassis. When you begin to feel resistance, pull up on the injector/ejector handle to fully inject the module into the chassis.

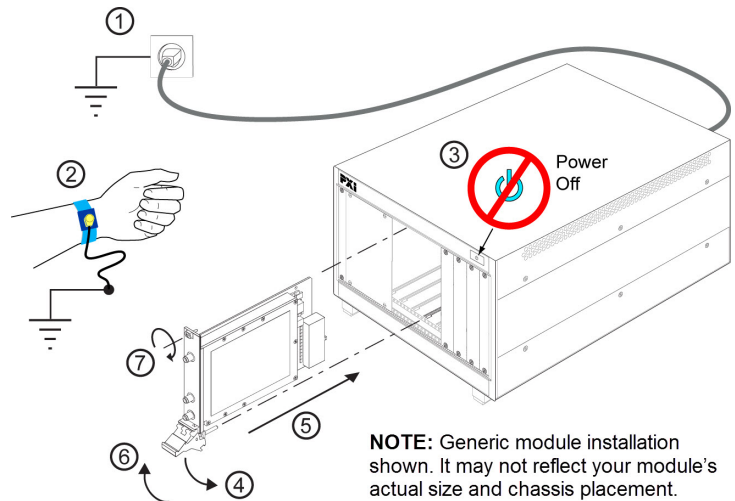

7. Secure all modules to the chassis using the module mounting screws. Use a #1 Pozidriv® or a slotted screwdriver and torque to 5 Lb-In (0.57 N-m). Performance may suffer if the screws are not tightened properly.
8. Verify that the PXI chassis fans are operable and free of dust and other contaminants that may restrict airflow.
9. Install filler panels and slot blockers after installing the modules. Missing filler panels or slot blockers may disrupt air circulation in the chassis. The left-most slot does not accept a slot blocker.
10. Your shipment included an Keysight M9310A PXIe Source Output. With this module you received a straight, coaxial adapter (1250-2316) (SMA female to SMA male). Connect this adapter to the RF Out connector of each M9310A, and torque to 8 Lb-In (0.904 Nm). **This will extend the life of this often-used connector.**
11. Use the Cabling Diagram plus the Cable and Module Table on the next page to attach the cables to the instrument. The torque specification for SMA connectors is 8 Lb-In (0.904 Nm).
12. If you are using a PCIe Cable Interface, such as the Keysight M9021, connect the Cable Interface in the chassis to the PC host per the instructions that came with the Cable Interface.
13. Power up the PXI chassis.
14. If you are using a remote PC, reboot the PC host.
15. Proceed to [Step 5: Verify Operation of the Keysight M9380A PXIe CW Source \(page 30\)](#).

Step 4: Install the Modules

## M9380A Instrument Connections

This section contains a cabling diagram for the Keysight M9380A PXIe CW Source, a cable and module association table, a table of Front Panel Features for each module, and a block diagram for the M9380A, with reference tables for each module.

### Keysight M9380A PXIe CW Source Cabling Diagram

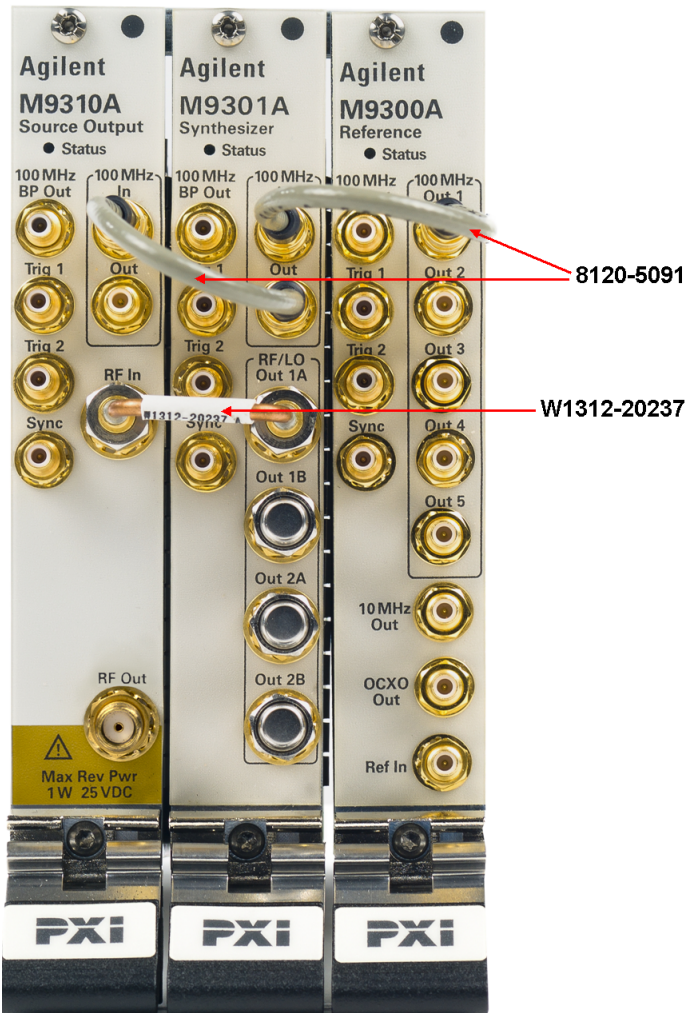

**Recommendation:** Install the semi-rigid cable first.

**CAUTION** Before removing cables from SMB and MMCX connectors, see ["Cable and Connector Care"](#) on page 23.

For front panel feature descriptions of the M9300A, see ["M9300A PXIe Frequency Reference Front Panel Features"](#) on page 24.

For front panel feature descriptions of the M9301A, see ["M9301A PXIe Synthesizer Front Panel Features"](#) on page 25.

For front panel feature descriptions of the M9310A, see ["M9310A PXIe Source Output Front Panel Features"](#) on page 26.

### M9380A Cable and Module Table

Keysight Part Number	Connection	Cable Description
8121-2063	This cable can be used to direct an External Reference into the M9300A Ref In connector.	Cable, coaxial, BNC (male) - SMB (female), 1200 mm
8120-5091	M9300A 100 MHz Out 1 to M9301A 100 MHz In	Cable, coaxial, SMB (female)-SMB (female)
8120-5091	M9301A 100 MHz Out to M9310A 100 MHz In	Cable, coaxial, SMB (female)-SMB (female)
W1312-20237	M9301A RF Out 1A to M9310A RF In	Cable, semi-rigid (SMA-SMA)

**Torque specification for all SMA connectors is 8 Lb-In (0.904 Nm).**

## Sharing the M9300A Frequency Reference

The M9300A Frequency Reference module can be shared by the up to five configurations of the M9380A CW Source or the M9381A Vector Signal Generator. If you connect to a hardware configuration that includes a currently connected M9300A (either independently or as part of another hardware configuration) the latest instance of the SFP will take control of the M9300A. You will see no warning or error message.

### CAUTION

While the M9300A module is being shared, any of the configurations that share this reference can control it fully, including setting the reference to use an external frequency reference source. If the external frequency reference setting does not match that of the supplied frequency, the reference will be unlocked, as expected. However, only the instance of the SFP that creates the reference unlock condition can correct the problem. This is done by either correcting the frequency or by setting the reference back to internal, so that a subsequent instance will not take control of the reference module unintentionally.

### CAUTION

The Reference module can also be shared among multiple measurement applications, such as the Keysight 89600 VSA software. The Reference module must be initialized before use, so including it in all configurations allows applications to be started in any order. However, when sharing a module the user interface of some applications may not reflect M9300A settings made by other applications. For example, the Keysight 89600 software can control the Reference module internal/external setting, but the changes made by other applications will not be reflected in the Keysight 89600.

### NOTE

FPGA updates are not allowed on a Keysight M9300A PXIe Frequency Reference while it is being shared. To perform M9300A FPGA updates, reserve the Reference.

## Reserving the Reference for a Configuration

#### Step 4: Install the Modules

If you are running a test in the background with a certain M9300A setting and then connect a hardware configuration that also contains the same M9300A, you may alter the test setup that is already running.

If you would prefer to keep the reference control with the first instance of the hardware configuration so that a subsequent instance will not take control of the reference module unintentionally:

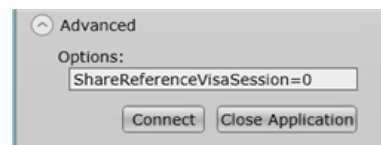

1. On the SFP Connect to Instrument screen, click the **Advanced** control to open the **Options:** dialog.
2. Type the following string: `ShareReferenceVisaSession=0`

This configuration will retain control of the M9300A if you try to open a new configuration. If you connect a new configuration, that includes the same M9300A, you will see the following error:

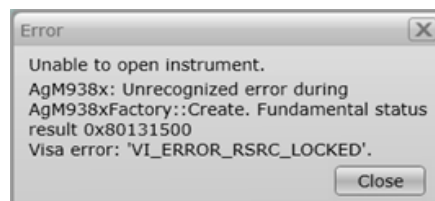

#### CAUTION

If an existing instance of the SFP is connected to the reference module in a shared (default) mode, and you try to connect a second instance of the SFP to the same reference with `ShareReferenceVisaSession=0` Advanced Option, you will get the resource locked error shown above.

### Cable and Connector Care

Use the Keysight Cable Removal Tool to disconnect push-on cables from the module front panel connectors.

**CAUTION** To avoid damage to the cables or connectors, pull the cable straight away from the connector. Do not use the tool as a pry bar.

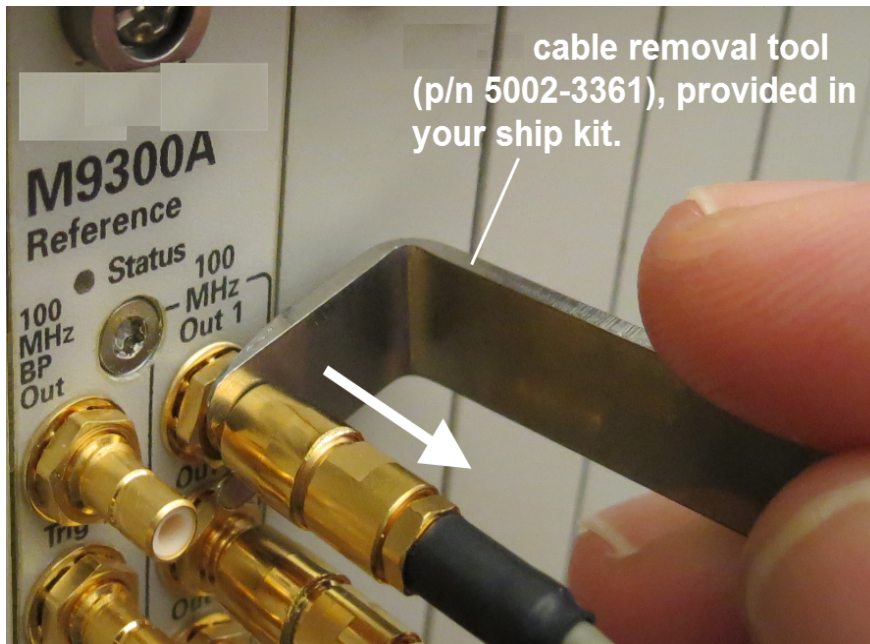

## M9300A PXIe Frequency Reference Front Panel Features

For parameter limits and specifications on the M9300A, see "M9380A Block Diagram Reference Table for M9300A" on page 27.

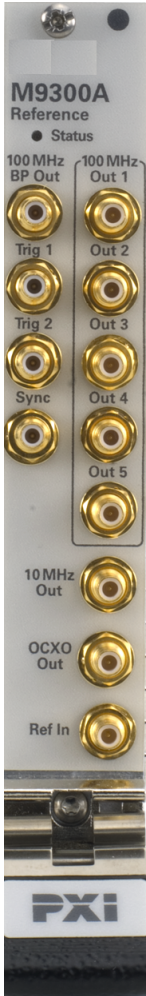

Connector	Description
100 MHz BP Out	This SMB male connector outputs a 100 MHz signal from the chassis backplane board. This output is enabled through the SFP.
100 MHz Out 1	Each of these SMB male connectors may output a 100 MHz reference and clock signal to the 100 MHz In connector of the Keysight M9301A PXIe Synthesizer.
5	
Trig 1	This connector is intended for future use.
Trig 2	This connector provides a programmable output trigger.
Sync	This connector is intended for future use.
10 MHz Out	This SMB male connector provides a 10 MHz signal. This output is enabled through the SFP.
OCXO Out	This SMB male connector provides a 10 MHz signal from the 10 MHz OCXO timebase. This output is enabled through the SFP.
Ref In	This SMB male connector inputs a 1 MHz to 110 MHz reference signal. The connector is AC coupled and terminated into 50 Ω.



## M9301A PXle Synthesizer Front Panel Features

For parameter limits and specifications on the M9301A connectors, see "[M9380A Block Diagram Reference Table for M9301A](#)" on page 28.



Connector	Description
100 MHz BP Out	This SMB male connector outputs a 100 MHz signal from the chassis backplane.
100 MHz In	This SMB male connector inputs a 100 MHz reference and clock signal from the 100 MHz Out connectors of the Keysight M9300A PXle Frequency Reference.
100 MHz Out	This SMB male connector outputs the 100 MHz Reference signal to the Keysight M9310A PXle Source Output 100 MHz In connector.
Trig 1	This SMB male connector accepts the External Input Trigger.
Trig 2	This SMB male connector is the List End Output Trigger.
Sync	This connector is intended for future use.
RF/LO Out 1A, 1B, 2A, 2B	These SMA female connectors (1A and 1B) are used to provide the RF In signal to the Keysight M9310A PXle Source Output. Connectors 2A and 2B are intended for future use. Unused connectors should be terminated with the provided 50 $\Omega$ loads.

## M9310A PXIe Source Output Front Panel Features

For parameter limits and specifications on the M9310A connectors, see "M9380A Block Diagram Reference Table for M9310A" on page 28.



Connector	Description
100 MHz BP Out	This SMB male connector outputs a 100 MHz signal from the chassis backplane.
100 MHz In	This SMB male connector inputs a 100 MHz reference signal from the 100 MHz Out connectors of the Keysight M9301A PXIe Synthesizer.
100 MHz Out	This SMB male connector outputs the 100 MHz Reference signal.
Trig 1	This SMB male connector accepts the Pulse RF Blanking Input Trigger.
Trig 2	This SMB male connector is the Source Settled Output Trigger.
Sync	This connector is intended for future use.
RF In	This SMA female connector inputs the RF signal from the Keysight M9301A PXIe Synthesizer RF Out connector.
RF Out	This SMA female connector outputs a CW RF signal of 1 MHz to 3 GHz or 6 GHz.

**CAUTION** To avoid damage, do not exceed 1 Watt (25 VDC) reverse power into the M9310A RF Out connector.

# M9380A Block Diagram

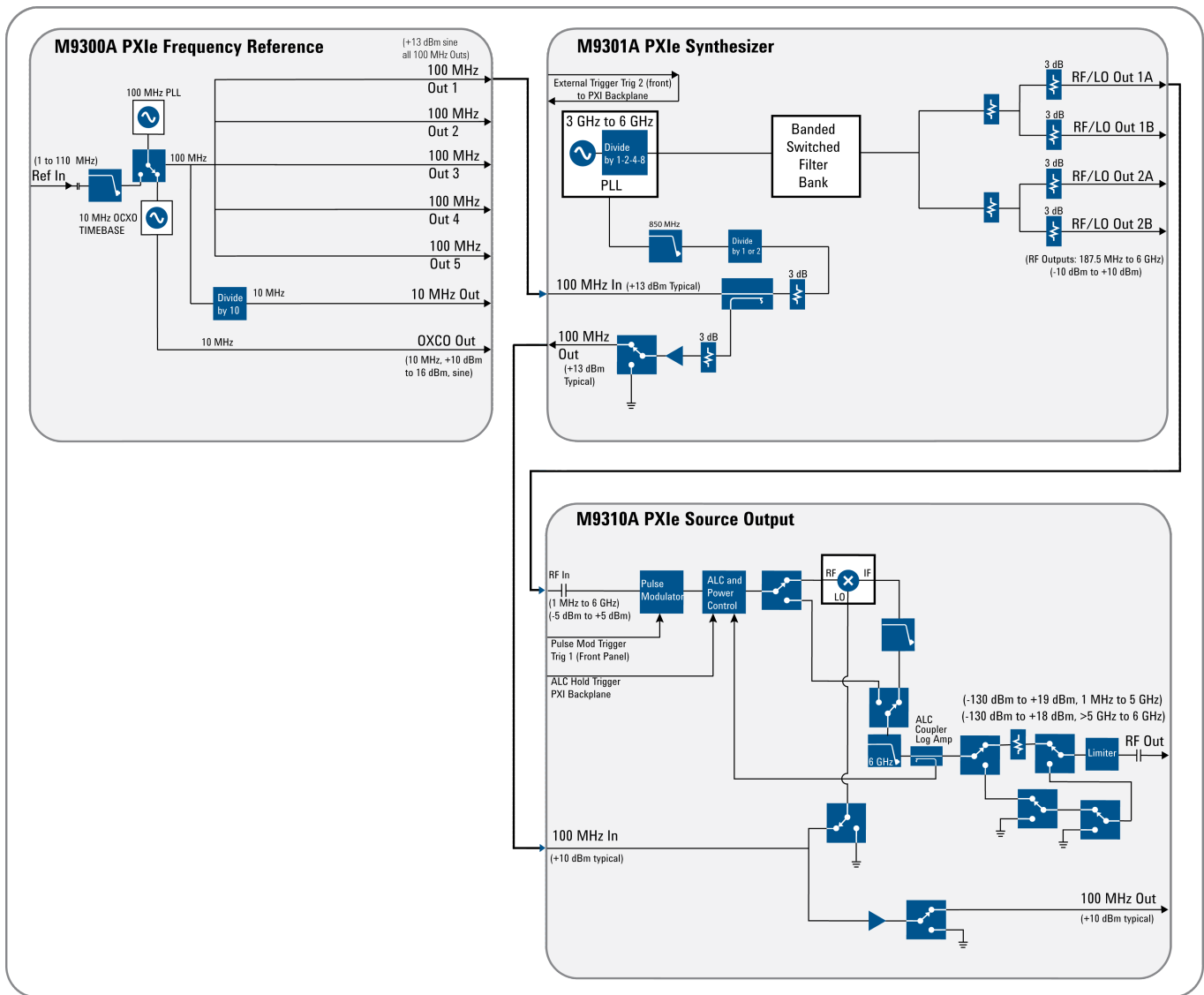

## M9380A Block Diagram Reference Table for M9300A

M9300A PXIe Reference Operation		
Input	Connector	Output
From: External Reference	Ref In	
Frequency: 1 MHz to 110 MHz		
Input Level: -5 dBm to +20 dBm		
	100 MHz Out 1-5	Frequency: 100 MHz Output level: >+12 dBm sine (+13 dBm typical)
	10 MHz Out	Output level: 3.3 Vpp square (1.65 v into 50 Ω)
	OXCO Out	Frequency: 10 MHz, AC coupled, 50 Ω source.

## M9380A Block Diagram

M9300A PXIe Reference Operation		
Input	Connector	Output
		Output level: +10 dBm to +16 dBm, from 10 MHz OCXO.
	Sync	This connector is intended for future use.
Sine or square wave -2 V to +5 V max into 50 $\Omega$ , +16 dBm max @ 0 VDC into 50 $\Omega$	Trigger 1 & 2 (In/Out)	3.3 V into 50 $\Omega$
From : Chassis back plane board Frequency: 100 MHz	100 MHz BP Out	Frequency: 100 MHz Output level: +10 dBm

## M9380A Block Diagram Reference Table for M9301A

M9301A PXIe Synthesizer Operation		
Input	Connector	Output
	RF/LO Out 1A, 1B, 2A, 2B	Frequency: 187.5 MHz to 6.0 GHz Output level: -10 dBm to +10 dBm
From: M9300A 100 MHz Out - frequency: 100 MHz, Amplitude: >+12 dBm @100 Hz: -130 dBc/Hz @1 kHz: -160 dBc/Hz	100 MHz In	
	100 MHz Out	To M9310A 100 MHz In Frequency: 100 MHz Output level: >+10 dBm (typical)
	Sync	This connector is intended for future use.
Sine or square wave -2 V to +5 V max into 50 $\Omega$ , +16 dBm max @ 0 VDC into 50 $\Omega$	Trigger 1 & 2 (In/Out)	3.3 V into 50 $\Omega$
Chassis back plane board	100 MHz BP Out	Frequency: 100 MHz Output level: >+10 dBm

## M9380A Block Diagram Reference Table for M9310A

M9310A PXIe RF Output Operation		
Input	Connector	Output
From: M9301A Synthesizer, RF Out 1A Frequency: 187.5 MHz to 6 GHz Input level: -10 dBm to +10 dBm	RF In	
	RF Out	Frequency: 1 MHz to 6 GHz Output level: -120 dBm to +10 dBm (standard power) Output level: +19 dBm (Option 1EA high power) for frequencies from 1 MHz to 5 GHz and +18 dBm for frequencies > 5 GHz to 6 GHz.
from: M9301A 100 MHz Out Frequency: 100 MHz	100 MHz In	

M9310A PXIe RF Output Operation		
Input	Connector	Output
Amplitude: >+12 dBm		
	Sync	This connector is intended for future use
Sine or square wave -2 V to +5 V max into 50 $\Omega$ , +16 dBm max @ 0 VDC into 50 $\Omega$	Trigger 1 & 2 (In/Out)	3.3 V into 50 $\Omega$ . Trig 1 Output .
Chassis back plane board	100 MHz BP Out	Frequency: 100 MHz Output level: >+10 dBm

## Step 5: Verify Operation of the Keysight M9380A PXIe CW Source

In this step you will verify correct operation of the Keysight M9380A PXIe CW Source. Before running a Self Test or performing a Calibration, assure that all required software is installed, the chassis is powered on, and all cabling is correct. See "M9380A Instrument Connections" on page 20" for proper cabling.

The first step in this process is to conduct a Self Test of the M9380A.

1. Open the M9380A soft front panel (SFP) by selecting **Start > All Programs > Keysight > M938x > M9380A SFP**.
2. Upon opening the SFP, you are presented with the "Connect to Instrument" dialog. Select all the modules that are components of the M9380A and press **Connect**. For example:

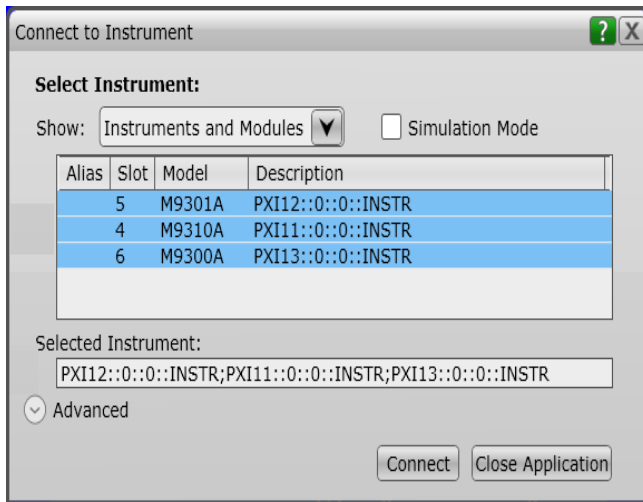

**NOTE** If no modules are visible in the SFP "Connect to Instrument" dialog, see "Communications" on page 33.

3. Conduct a Self Test (**Utilities > Self Test... > Run Self Test**). The M9380A Self Test runs each module through its own Self Test.

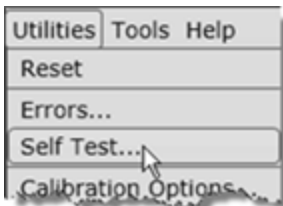

If the Self Test passes (see results below), go to [Step 6: Installation is Complete \(page 31\)](#).

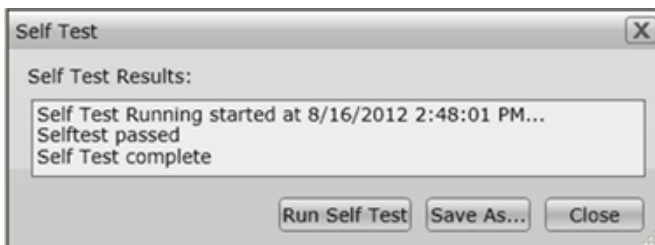

**CAUTION** If the Self Test fails, it indicates which module is likely to need service. See "M9380A Troubleshooting" on page 33 to ascertain the source of the failure.

## Step 6: Installation is Complete

Proceed to program your product by means of the applications programming interface (API) for the supplied drivers.

### API Overview

#### IVI Drivers

Keysight's IVI drivers simplify the creation and maintenance of instrument control applications in a variety of development environments; they allow programmatic control of instrumentation while providing a greater degree of instrument interchangeability and code reuse. IVI drivers currently come in two basic types: IVI-COM and IVI-C. Although the functionality offered by both types of drivers is often very similar, the fundamental differences in interface technology results in a very different end-user experience. The IVI drivers support compiling application programs for 32- or 64-bit platforms.

**Supported ADEs** (application development environments) Arguably the most important consideration in comparing IVI-COM and IVI-C drivers is the end user experience in various ADEs. Since IVI-COM drivers are based on Microsoft COM technology, it's not surprising that IVI-COM drivers offer the richest user experience in Microsoft ADEs. Users working in Visual C++, Visual C#, Visual Basic.NET, and Visual Basic 6 enjoy a host of features, such as object browsers, IntelliSense, and context-sensitive help.

When you install the product software, the IVI driver files are installed in the standard IVI Foundation directories (for example, C:\Program Files\IVI Foundation\IVI\Drivers\AgM938x). Example programs are provided to demonstrate most driver functionality (for example, C:\Program Files\IVI Foundation\IVI\Drivers\AgM938x Source\Examples). The reference material for the driver functions (a Microsoft HTML Help .chm file) is installed with the IVI driver and is available for Microsoft Visual Studio's IntelliSense context linking. In addition, you can directly access the .chm file (AgM938x.chm) from this Start menu location: **Start > All Programs > Keysight IVI Drivers > AgM938x Source > Documentation**.

#### LabVIEW Driver

In addition to the IVI drivers, Keysight provides a LabVIEW driver that includes all the functionality of the IVI-C driver. When you install the product software, the LabVIEW driver is installed to each LabVIEW instr.lib directory for each version of LabVIEW you have on your computer (for example, C:\Program Files (x86)\National Instruments\<LabVIEW version>\instr.lib\<Agilent product model>). If you install LabVIEW drivers before

you install LabVIEW itself, drivers will be installed in the Agilent directory instead of the National Instruments directory (for example, C:\Program Files (x86)\Agilent\<Agilent product model>\LabVIEW Driver-\<LabVIEW version>\...). Example programs are provided to demonstrate most driver functionality. The reference information for the driver (a Microsoft HTML Help .chm file) is also installed with the driver and the content is available from LabVIEW's Context Help window. In addition, you can directly access the chm file (AgM938x\_LabVIEW\_Help.chm) from this Start menu location: **Start > All Programs > Keysight > M938x > M938x LabVIEW Help.**

## M9380A Specifications

The Data Sheet for the M9380A is included on the Software and Product Information CD (M9300-10002) that came with your module. This document contains specification information. Please check the Keysight website at [www.keysight.com/find/M9380A](http://www.keysight.com/find/M9380A) for the latest updates to this information. The Data Sheet for the M9380A can also be found in PDF format at <http://cp.literature.keysight.com/litweb/pdf/5991-0283EN.pdf>.



## M9380A Troubleshooting

### Communications

If you are unable to communicate with the M9380A verify that the following installations are correct:

- Keysight IO Libraries Suite
- M9380A SFP program
- Module and chassis drivers
- System Interface Card, cable and PC PXIe card connections, if you are using an external host PC

If not all modules and their slot locations are visible in the SFP "Connect to Instrument" dialog:

1. Close the SFP.
2. Start Keysight Connection Expert, by selecting **Start > All Programs > Keysight Connection Expert**. If any or all modules and their slot locations are still not visible, select **Refresh All**.
3. Restart the SFP.

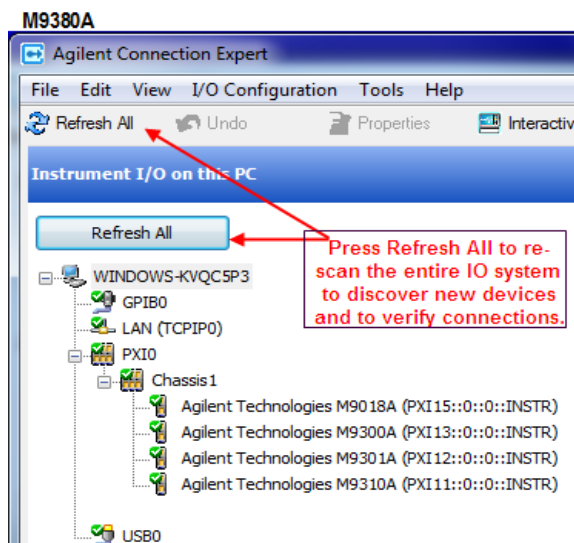

### Module-Level Troubleshooting Overview

1. Start by verifying ALL cables are properly connected and SMA connectors are torqued to 8 Lb-In (0.904 Nm). See ["M9380A Instrument Connections" on page 20](#) for instrument-level cabling.
2. Check the front panel Status LEDs. See ["Status LED States" on page 34](#).
3. Check the M9380A SFP Instrument Status window and Self Tests.
4. Perform a module-level troubleshooting check.

## Status LED States

**NOTE** Once you open the M9380A SFP, select all relevant modules, and then choose Connect. The modules are initialized. Until a module is initialized, the LEDs are off.

Module	Green	Orange	Red	Off
<b>M9300A</b>	The Soft Front Panel has initialized the connection to the module	n/a	Indicates that the VCXO is unlocked.	<ul style="list-style-type: none"> <li>Not connected by the SFP.</li> <li>Failure in the power supplies. Module hardware health can't be determined until the power supply failure is resolved.</li> </ul>
<b>M9301A</b>	The Soft Front Panel has initialized the connection to the module	Tuning is in progress, or the M9301A is unlocked from the reference.	n/a	<ul style="list-style-type: none"> <li>Not connected by the SFP.</li> <li>Failure in the power supplies. Module hardware health can't be determined until the power supply failure is resolved.</li> </ul>
<b>M9310A</b>	The Soft Front Panel has initialized the connection to the module	n/a	n/a	<ul style="list-style-type: none"> <li>Not connected by the SFP.</li> <li>Failure in the power supplies. Module hardware health can't be determined until the power supply failure is resolved.</li> </ul>

### M9380A Soft Front Panel Self Tests

Start the SFP self tests by selecting: **Utilities > Self Test > Run Self Test**. Once completed, a dialog box appears and reports on each of the modules, indicating if it passed or failed.

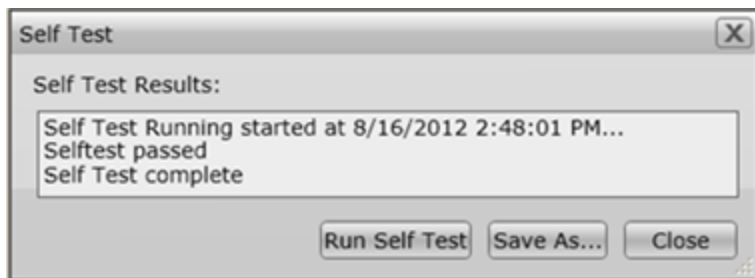

## M9300A PXIe Frequency Reference Troubleshooting

Start the soft front panel (SFP) self test by selecting **Utility > Self Test > Run Self Test**. Once completed, a dialog box appears and reports whether the MMI passed or failed Self Test.

Please refer to the following table for recommended hardware. Additionally, a high quality flexible 3.5 mm cable is required, plus adapters to connect the PSG (precision signal generator) and signal analyzer.

Hardware	Description	Critical parameters
Keysight N9020A Option 508 or N9030A Option 508 or E44454A	Signal Analyzer	1 MHz to 6 GHz
Keysight N5181A	Source or Function Generator	1 MHz to 110 MHz, 0 to 10 dBm

### Ref In Connector

1. On the M9380A SFP, select the "Reference" tab and under "External" select "Use External Reference."

**NOTE** The External Reference status indicator will show an "Unlocked" condition and the Status LED on the M9300A front panel will turn red until an external reference is applied.

2. Connect an external source or function generator output to the M9300A "Ref In" connector.
3. Set the source/function generator to the first frequency and power level listed in the following table.
4. On the SFP (under External Reference) enter the external reference frequency in "Frequency".
5. Verify that the Reference is locked, using the SFP Reference Status indicators.
6. Set the source/function generator to each frequency and power level listed in the following table, and verify that the reference locks.

SFP External Reference Frequency	Source Frequency	Source Power Level (sine)
1 MHz	1 MHz	+10 dBm
1 MHz	1 MHz	0 dBm
10 MHz	10 MHz	+10 dBm
10 MHz	10 MHz	0 dBm
100 MHz	100 MHz	+10 dBm
100 MHz	100 MHz	0 dBm
110 MHz	110 MHz	+10 dBm
110 MHz	110 MHz	0 dBm

**NOTE** Cable loss must be considered, when determining the results.

7. If the Reference remains locked at all frequencies and power levels, proceed to the next test.
8. If the Reference loses lock, the module is defective and should be repaired. [See "Return an Instrument for Service" on page 11.](#)

9. Uncheck, "Use External Reference" and remove the cable from the Ref In connector.
10. If the Reference loses lock, the module is defective and should be repaired. See "Return an Instrument for Service" on page 11.

### 100 MHz Out 1 through 5 Connectors

1. Set the signal analyzer reference level to +20 dBm, and the center frequency to 100 MHz.
2. On the SFP, under the Reference tab and under 100 MHz Reference, check Enable Out 1-5.
3. On the SFP, under External, verify that "Use External Reference" is unchecked (disabled.)
4. Connect the RF INPUT on the signal analyzer to the 100 MHz Out 1 connector on the M9300A.
5. The output level should be  $\geq 10$  dBm.
6. Measure the power out of 100 MHz Out 2 through 5 for  $\geq 10$  dBm.
7. On the SFP, disable (uncheck) 100 MHz Out 1 through 5.
8. Repeat the measurement of power on 100 MHz Out 1 through 5.
9. The power level should be  $\sim 20$  dB less than measured when the outputs were enabled.
10. If any power level fails (when enabled or disabled) the Reference module needs to be repaired. See "Return an Instrument for Service" on page 11.

### 10 MHz Out, 100 MHz BP Out and OCXO Out Connectors

1. On the SFP under the "Reference" tab, find "Miscellaneous". Select and enable 100 MHz BP, 10 MHz Out, and OCXO Out.
2. Set the signal analyzer center frequency to 10 MHz, reference level to 20 dBm and span to 1 kHz.
3. Connect the signal analyzer to 10 MHz OCXO Out on the M9300A.
4. Verify that the 10 MHz OCXO power level is  $\geq +9$  dBm.
5. Connect the signal analyzer to the 10 MHz Out connector and verify that the power is  $\geq +7$  dBm.
6. Set the signal analyzer center frequency to 100 MHz and the span to 50 kHz.
7. When the 10 MHz Out and OCXO Out controls are Enabled and there is no or low signal present, the module is defective and needs to be repaired. See "Return an Instrument for Service" on page 11.
8. Set the signal analyzer center frequency to 100 MHz and the span to 50 kHz.
9. Connect the signal analyzer to the 100 MHz BP Out connector and verify that the power is  $\geq +10$  dBm.
10. If the power level is low, the module is defective and needs to be repaired. See "Return an Instrument for Service" on page 11.

## M9301A PXIe Synthesizer Troubleshooting

This procedure requires that you:

- Install the M9301A module into an appropriate chassis with all other M9380A modules.
- Open the M9380A SFP interface.
- Connect the M9301A 100 MHz In connector to one of the M9300A 100 MHz Out (1 through 5) and enable that output from the Reference tab of the SFP.

### RF Out 1A/B, 2A/B Connectors

1. Connect the M9300A 10 MHz Out to the signal analyzer 10 MHz Ext. Ref In.
2. Under the Reference tab on the SFP:
  - a. Enable the 100 MHz Out connector that is connected to the M9301A (default state).
  - b. Under "Miscellaneous" enable the 10 MHz Out. This is the default state.
3. Verify that the signal analyzer External Reference indicator is on.
4. Connect the M9301A RF/LO Out 1A connector to the signal analyzer RF INPUT.
5. Set the signal analyzer:
  - a. Reference level: +20 dBm
  - b. Span: 500 MHz
  - c. Reference bandwidth and resolution bandwidth to Auto.
  - d. Center Frequency: 1 GHz
6. Set the M9380A, using the SFP, and the signal analyzer to the first of the frequencies listed below:
  - 1.0 GHz
  - 2.0 GHz
  - 3.0 GHz

The following frequencies apply only to Option F06 (6 GHz frequency range):

- 3.05 GHz
  - 5.0 GHz
  - 6.0 GHz
7. On the signal analyzer, verify that the power level out of RF/LO Out 1A and 1B is  $\geq -3$  dBm at all frequencies in Step 6.
  8. Also, verify that the power level out of RF/LO Out 2A and 2B is  $\geq -13$  dBm at all frequencies in Step 6.
  9. If any RF/LO Out connector fails to provide a signal or a signal within the limits, the M9301A needs to be repaired. [See "Return an Instrument for Service" on page 11.](#)

**NOTE** Cable loss must be considered, when determining the results.

### 100 MHz In, and 100 MHz Out

1. On the SFP Reference tab, verify that the 100 MHz Out 1 Enabled box is checked.
2. Set the signal analyzer to 100 MHz and the reference level to +20 dBm.
3. Connect the signal analyzer to the M9301A 100 MHz Out connector and verify that the signal level is >+10 dBm.
4. On the SFP Reference Tab, deselect 100 MHz Out.
5. The 100 MHz signal on the signal analyzer should decrease by ~ 20 dB.
6. Re-enable 100 MHz Out and the 100 MHz signal should reappear.
7. Remove the M9301A 100 MHz In and the 100 MHz signal on the signal analyzer should disappear.
8. Reconnect the 100 MHz input from the M9300A.
9. Verify that the signal returns.
10. If the module fails any of the above tests, it needs repair. See ["Return an Instrument for Service" on page 11](#).

## M9310A PXIe Source Output Troubleshooting

**NOTE** Before proceeding, check the outputs of the M9301A and M9311A (if applicable).

1. Verify that all module interconnect cables are properly connected. See ["M9380A Instrument Connections"](#) on page 20.
2. Set the signal analyzer to
  - a. Reference level: 30 dBm
  - b. Span: 1 MHz
  - c. Reference Bandwidth and Resolution Bandwidth set to "Auto"
3. Using the SFP, set the Amplitude to +10 dBm for a standard instrument or +19 dBm for a high power instrument (Option 1EA), turn RF On, and ALC On.
4. Connect the M9310A RF Out to the signal analyzer RF In.
5. Using the list below, set the SFP and signal analyzer frequencies and verify the power levels. A Standard M9310A should have an output of +10 dBm. An M9310A with High Output Power Option 1EA should have an output of +19 dBm for frequencies up to 2.5 GHz, and +18 dBm for frequencies above 2.5 GHz.

**NOTE** Cable loss must be considered, when determining the results.

- 1 MHz
  - 390 MHz
  - 1.0 GHz
  - 3.0 GHz
  - 6.0 GHz (This frequency applies only to an M9310A with High Frequency Option F06.)
6. If the modules fails at any frequency, it is defective and needs repair. See ["Return an Instrument for Service"](#) on page 11.

