



Medalist i3070 Series 5i Inline ICT System

i3070 Series 5i Help

Notices

© Agilent Technologies, Inc. 2013

No part of this manual may be reproduced in any form or by any means (including electronic storage and retrieval or translation into a foreign language) without prior agreement and written consent from Agilent Technologies, Inc. as governed by United States and international copyright laws.

Warranty

The material contained in this document is provided "as is," and is subject to being changed, without notice, in future editions. Further, to the maximum extent permitted by applicable law, Agilent disclaims all warranties, either express or implied, with regard to this manual and any information contained herein, including but not limited to the implied warranties of merchantability and fitness for a particular purpose. Agilent shall not be liable for errors or for incidental or consequential damages in connection with the furnishing, use, or performance of this document or of any information contained herein. Should Agilent and the user have a separate written agreement with warranty terms covering the material in this document that conflict with these terms, the warranty terms in the separate agreement shall control.

Technology Licenses

The hardware and/or software described in this document are furnished under a license and may be used or copied only in accordance with the terms of such license.

Restricted Rights Legend

If software is for use in the performance of a U.S. Government prime contract or subcontract, Software is delivered and licensed as "Commercial computer software" as defined in DFAR 252.227-7014 (June 1995), or as a "commercial item" as defined in FAR 2.101(a) or as "Restricted computer software" as defined in FAR 52.227-19 (June 1987) or any equivalent agency regulation or contract clause. Use, duplication or disclosure of Software is subject to Agilent Technologies' standard commercial license terms, and non-DOD Departments and Agencies of the U.S. Government will receive no greater than Restricted Rights as defined in FAR 52.227-19(c)(1-2) (June 1987). U.S. Government users will receive no greater than Limited Rights as defined in FAR 52.227-14 (June 1987) or DFAR 252.227-7015 (b)(2) (November 1995), as applicable in any technical data.

Safety Notices

CAUTION

A **CAUTION** notice denotes a hazard. It calls attention to an operating procedure, practice, or the like that, if not correctly performed or adhered to, could result in damage to the product or loss of important data. Do not proceed beyond a **CAUTION** notice until the indicated conditions are fully understood and met.

WARNING

A **WARNING** notice denotes a hazard. It calls attention to an operating procedure, practice, or the like that, if not correctly performed or adhered to, could result in personal injury or death. Do not proceed beyond a **WARNING** notice until the indicated conditions are fully understood and met.

Contents

1 Getting Started

- Safety Information 1-2
 - Warning and Hazard Labels 1-2
 - Emergency Stop 1-2
- Overview 1-3
- System Hardware 1-4
 - Manual Control Panel 1-7
- System Software 1-8
 - Medalist i3070 Software 1-8
 - LCD Touch Panel Program 1-8
- Starting the Medalist i3070 Series 5i 1-9
- Shutting Down the Medalist i3070 Series 5i 1-11

2 Touch Panel Functions

- Modes of Operation 2-2
- Maintenance Mode 2-3
 - Test Settings 2-5
- Debug Mode 2-7

3 Test Development

- Test Development Overview 3-2
- Fixturing Guidelines 3-3
 - Board Placement and Specifications 3-3
 - Bottom Fixture 3-5
 - Top Fixture 3-7
 - Guide Pin 3-8
 - Top Fixture Height After Compression 3-9
 - ID Block 3-10
 - Optional Signals 3-13
- Fixture Setup and Debugging 3-15
 - Fixture Setup 3-15
 - Verify the Fixture 3-25

4 Production Setup and Testing

- Production Setup 4-2
- Production Testing 4-3

Service and Maintenance

5 Maintenance

- Calibration 5-2
- General Cleaning 5-3
- Lubrication Procedures 5-4
 - Press: Ballscrew and Ballscrew Nut 5-5
 - Press: Linear Shafts 5-6
 - Press: Runner Blocks 5-7
 - Zone 1 Conveyor: Leadscrew and Spline Shaft 5-8
 - Zone 1 Conveyor: Bevel Gears and Chain 5-9
 - Zone 2 Conveyor: Runner Blocks 5-10
 - Drawer: Guide Shafts 5-11
 - Testhead: Spur Gears 5-12

6 Troubleshooting

- System Diagnostics 6-2
- General System Troubleshooting 6-3
 - Tower Light Indications 6-3
 - Error Messages and Remedial Actions 6-4
- Sensor Calibration and Troubleshooting 6-8
 - Calibrating PHS-13 (Presser Lower Limit Sensor) 6-8
 - Troubleshooting PHS-1 to PHS-7 6-11
 - Troubleshooting PHS-12 to PHS-14, PHS-24 to PHS-26 6-12
 - Troubleshooting PHS-16 and PHS-17 6-14
 - Sensor Layout 6-15

7 Replacement Procedures

- Accessing the Testhead 7-2
- Replacing Cards in the Testhead 7-5
- Replacing i-System Card 7-8
- Replacing Runner Blocks 7-10
 - Testhead Runner Blocks 7-10
 - Press Lower Runner Block 7-12
 - Press Upper Runner Block 7-15
 - Zone 2 Conveyor Runner Block (Up/Down) 7-17
 - Zone 2 Conveyor Runner Block (Width Adjustment) 7-19
- Replacing Module Power Unit (MPU) 7-21
- Installing DUT Power Supply 7-23

Replacing Servo Motor	7-27
Replacing Press Components	7-31
Replacing Zone 1 Conveyor Belt	7-35
Zone 1 Conveyor Belt (Movable Side)	7-35
Zone 1 Conveyor Belt (Fixed Side)	7-37
Replacing Zone 2 Conveyor Belt/Spring	7-39
Zone 2 Conveyor Belt (Movable Side)	7-40
Zone 2 Conveyor Belt (Fixed Side)	7-42
Compression Spring (Movable Side)	7-44
Compression Spring (Fixed Side)	7-46
Replacing Conveyor Motors	7-48
Zone 1 Conveyor Motor	7-48
Zone 2 Conveyor Motor (Movable Side)	7-50
Zone 2 Conveyor Motor (Fixed Side)	7-51

8 Firmware Update

Update PLC Firmware	8-2
Back Up PLC Firmware	8-4
Update LCD Touch Panel Firmware	8-5
Back Up LCD Touch Panel Firmware	8-6
Electrical Diagrams	9-2



1 Getting Started

Safety Information 1-2

Overview 1-3

System Hardware 1-4

System Software 1-8

Starting the Medalist i3070 Series 5i 1-9

Shutting Down the Medalist i3070 Series 5i 1-11







Safety Information

Warning and Hazard Labels

Pay attention to the following labels when they appear on the equipment.

Table 1-1 Warning Labels on the Equipment

Label	Description
	DANGER: High Voltage Do not detach the protective covers. Operating this equipment without covers may cause electric shock.
	WARNING: Moving Parts (General) Do not touch the equipment while it is running. Keep clear of moving machinery.
	WARNING: Moving Parts (Hand) Do not touch the equipment while it is running. Keep hands clear of moving machinery.
	WARNING: Pinch Hazard Do not touch the equipment while it is running. Keep hands away from the indicated areas to avoid pinched fingers.

Emergency Stop



In case of emergency, press the red **Emergency Stop** switch (Figure 1-1) to cut off power to the system.

Resetting the Emergency Stop

- 1 Turn the red **Emergency Stop** switch clockwise to release it.
- 2 Press the **Reset** button to reset the safety relay and resume operation.

Resetting the Emergency Stop

- 1 Turn the red **Emergency Stop** switch clockwise to release it.
- 2 Press the **Reset** button to reset the safety relay and resume operation.

Overview

Agilent's Medalist i3070 Series 5i Inline In-Circuit Test (ICT) system is designed to bring all the industry-leading ICT technologies into a fully automated manufacturing line.

It comes with a full suite of Agilent ICT solutions, including:

- Cover-Extend Technology - Enables tests for PCBAs which would otherwise be inaccessible using traditional ICT probing methods.
- Throughput Multiplier - Boosts test throughput by testing multiple boards simultaneously.
- Autodebug - Reduces debug time.
- AutoOptimizer - Optimizes test times for repeated tests.
- Agilent Utility Card - Allows easy plug-in of third-party test modules for flash programming, boundary scan and LED tests.

Short-wire fixturing technology ensures transportability, reliability and stability, while its innovative design ensures easy maintenance and fixture change.

Built for SMEMA compatibility, the Agilent i3070 Series 5i is easily integrated into existing SMT lines. It can be deployed in island mode or inline mode, with the conveyor belt configured as Left-handed or Right-handed system (direction in which the DUT enters the ICT system).

System Hardware

- Testhead

The two-module testhead contains the hardware resources required to execute tests. Each module in the testhead holds the following cards:

 - A Mother Card
 - A Module Control Card
 - An ASRU Card
 - Up to nine pin cards
- Test Fixture

The test fixture is the hardware interface between the testhead and the board or device under test (DUT).
- Controller

The controller is the computer that controls the test system. The controller pod also houses the System Card and DUT power supplies.
- System Card

The System Card System card is the conduit for communication between the testhead modules and controller. It provides the means to detect and respond to safety events, actuate fixture vacuum and pull-down towers, and actuate auxiliary connection relays.

Figure 1-1 Medalist i3070 Series 5i (Left-to-Right System)

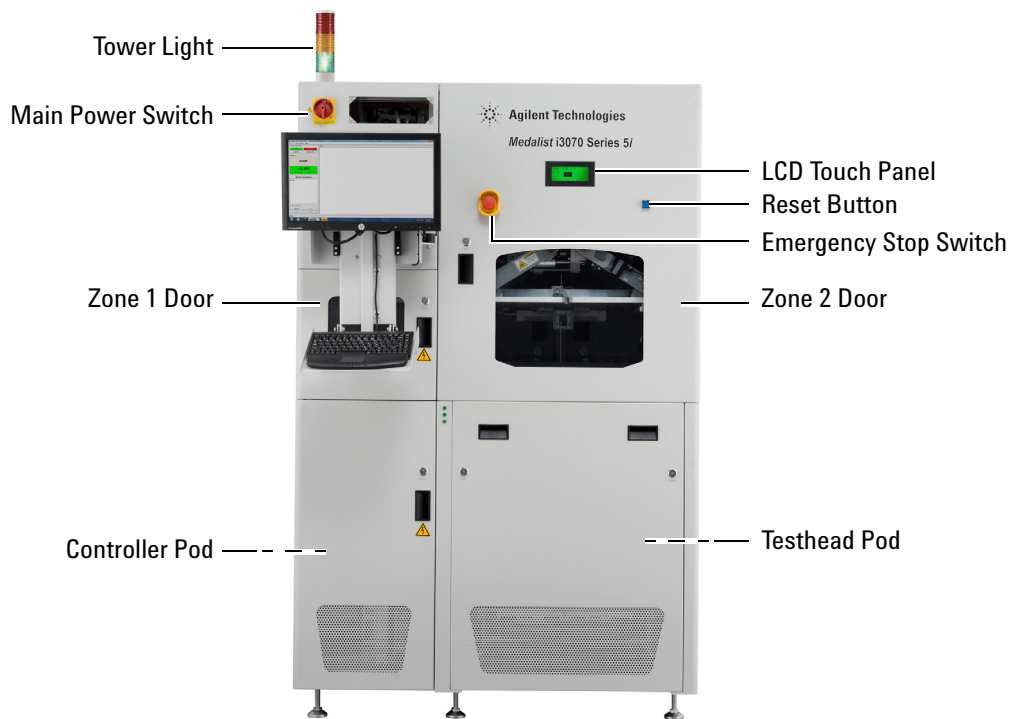

Figure 1-2 Zone 1 – Front View

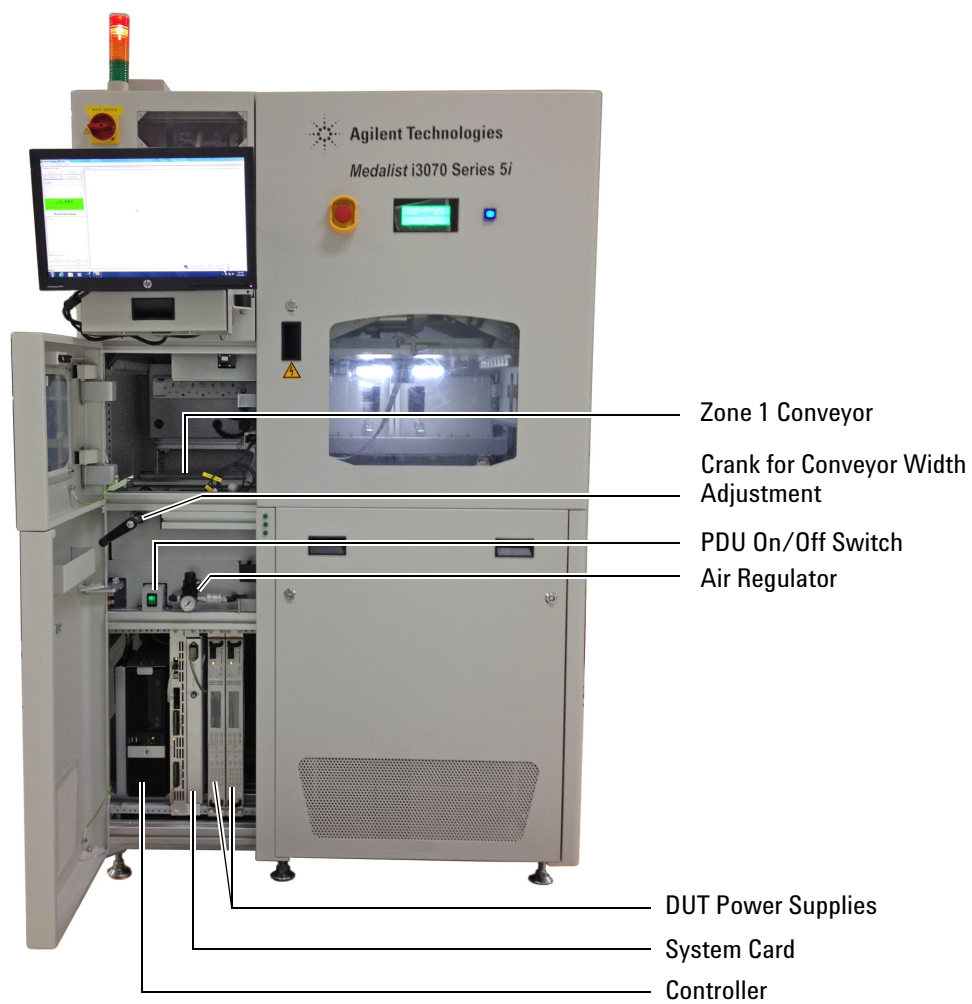

Figure 1-3 Zone 2 – Front View

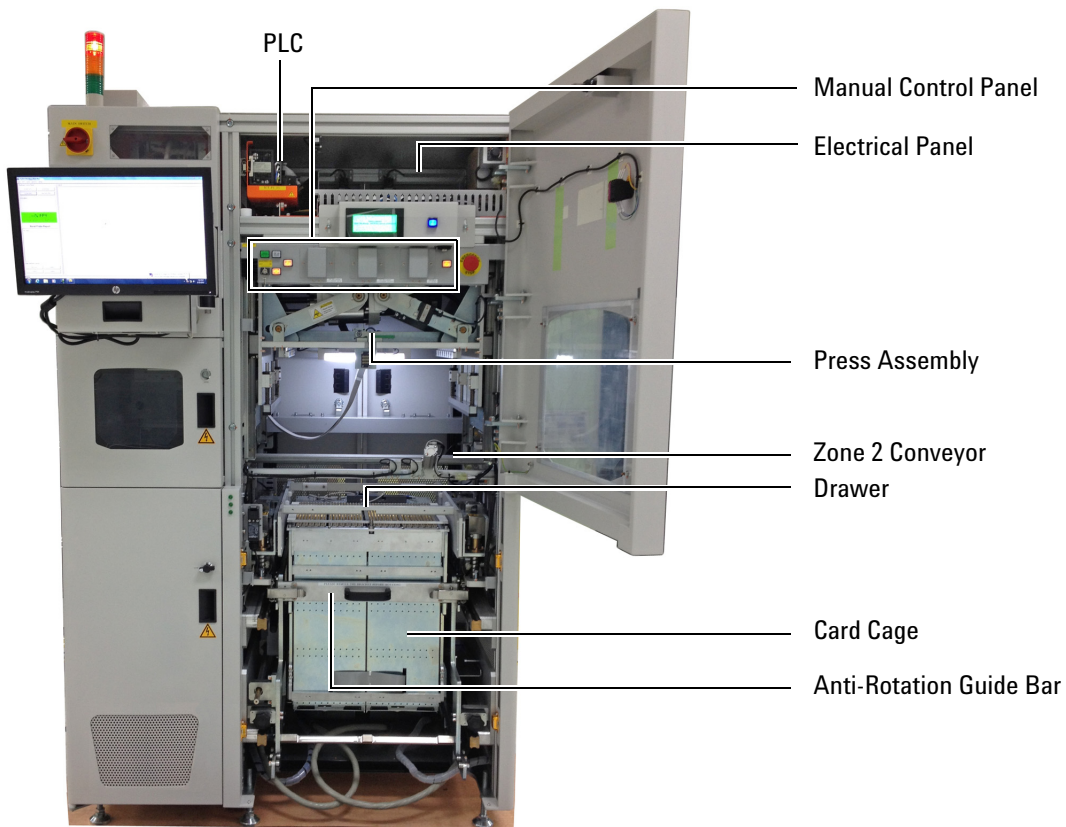
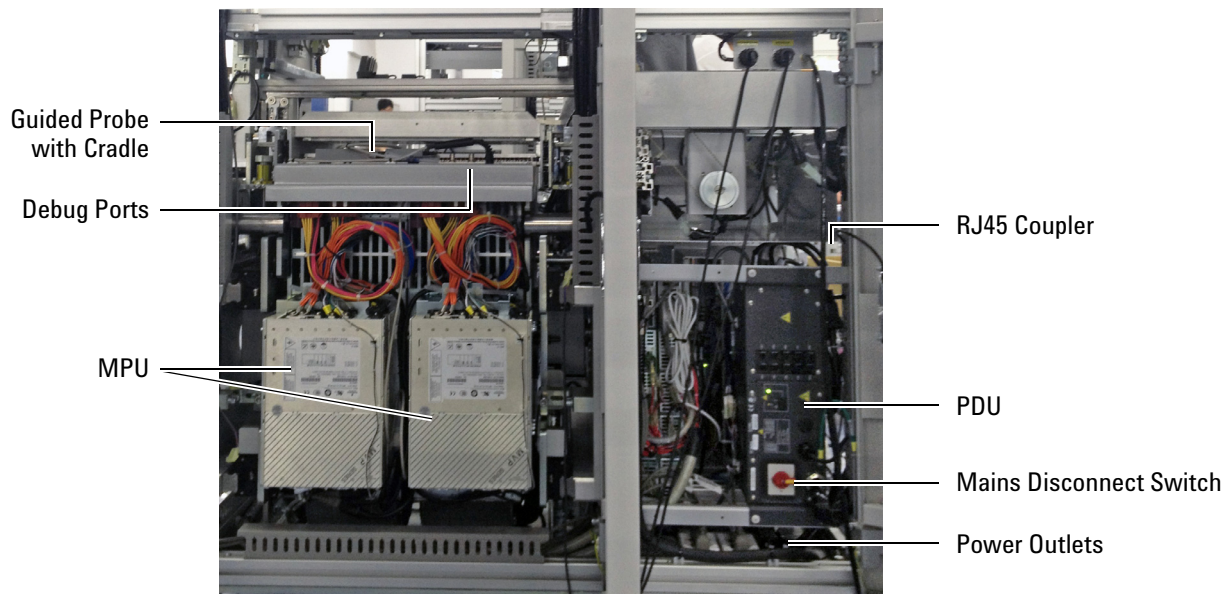

Figure 1-4 Rear View



Manual Control Panel

Open the Zone 2 door to access the manual control panel.

Figure 1-5 Manual Control Panel



Table 1-2 Manual Control Panel

	Button/Switch	Description
1	MAINTENANCE KEY SWITCH	Off – Enable Production Mode. On – Enable Maintenance/Debug Mode; allows system to operate with the doors open.
2	TOP JIG LOCK	Lock the top fixture.
3	BOTTOM JIG LOCK	Lock the bottom fixture.
4	DRAWER CONTROL 1 DRAWER CONTROL 2	Press both buttons to move the drawer up or down.
5	TESTER SELFTEST	(not used)

System Software

Medalist i3070 Software

The Medalist i3070 software release 08.30si provides the test development environment as well as the Operator Interface for production testing. See [Test Development](#) to get started on the test development process.

LCD Touch Panel Program

The LCD touch panel lets you select the mode of operation.

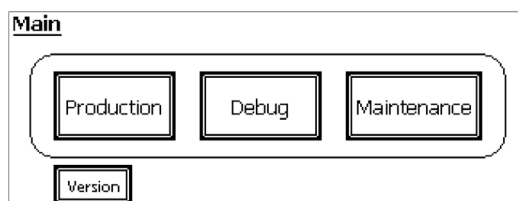

Select **Production** mode for production testing.

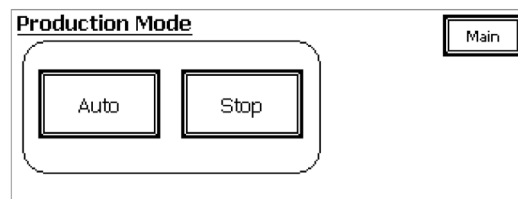

Both Debug and Maintenance modes require a password. Maintenance mode lets you calibrate and set up the system for production. The functions are described in detail in [Touch Panel Functions](#).

Entering a Password

When a password is required, the following password page is displayed:

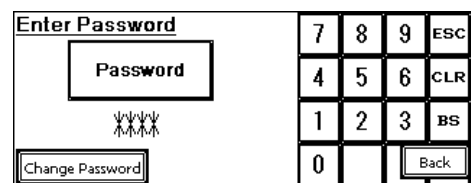

- 1 Press **Password**.
- 2 Key in the password and press **Enter**.
(The default password is **1263**.)

Starting the Medalist i3070 Series 5i

Start the system following the sequence below. See [Figure 1-6](#).

- 1 Turn the Main Power Switch to ON.

The LCD touch panel will display the Main page.

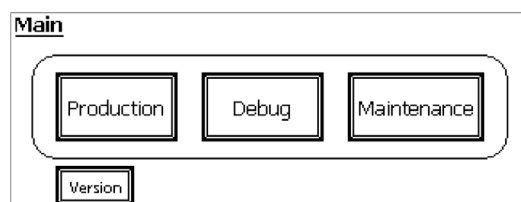

- 2 Press **Reset** to reset the safety relays.
Open the controller pod cover to access the following switches:
- 3 Turn ON the PDU on/off switch that enables power to the testhead.
- 4 Turn ON the DUT power supply.
- 5 Turn ON the controller and monitor.
- 6 Log on to the system. ([Table 1-3](#) lists the default user names.)
- 7 Boot the testhead:
 - a Open a Korn Shell window and type `dgn` at the command line.
 - b In the DGN window, select **Testhead Functns** and boot the testhead using **Testhead Power On**.

Figure 1-6 Power Up Sequence

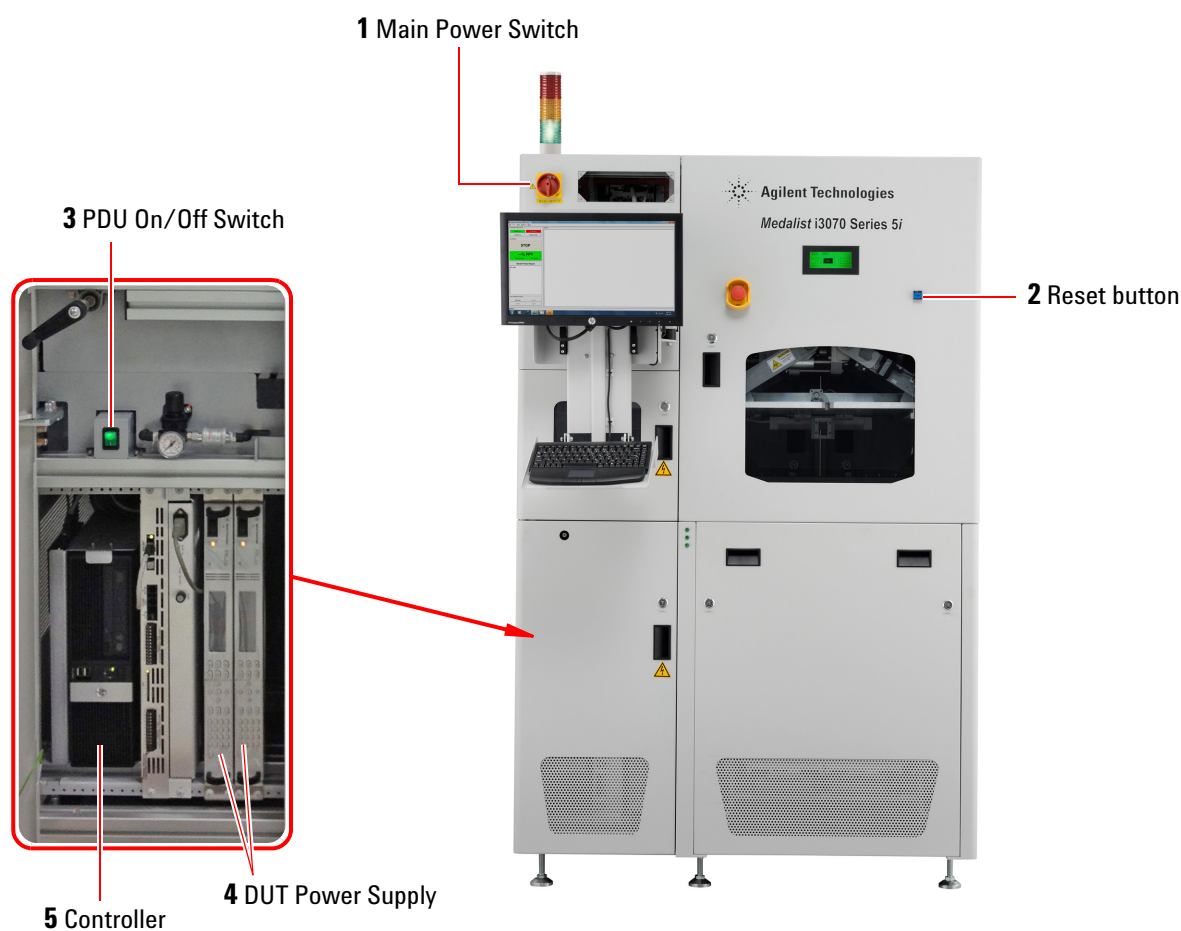

Table 1-3 Agilent Medalist ICT system users

User Name	Default Password	Definition and Permissions
operator	Resetme1	For operators who are using the Operator Interface to test boards.
tcm	Resetme1	For operators who are using BT-Basic to test boards.
user	Alterme1	For general users or sustaining engineers.
engineer	Alterme1	For test developers or sustaining engineers.
calibrate	Agilent1	Used for system calibration and maintenance. This user has administrative rights.

Shutting Down the Medalist i3070 Series 5i

- 1 From the Medalist i3070 software, select **File > Exit**.
- 2 Unboot the testhead:
 - a Open a Korn Shell window and type `dgn` at the command line.
 - b In the DGN window, select **Testhead Funct**s and unboot the testhead using **Testhead Power Off**.
- 3 Log off Windows.
- 4 Turn OFF the PDU on/off switch.
- 5 Turn OFF the DUT power supply.
- 6 Turn the Main Power Switch to OFF.



2 Touch Panel Functions

Modes of Operation [2-2](#)

Maintenance Mode [2-3](#)

Debug Mode [2-7](#)



Modes of Operation

On the LCD touch panel, the Main page appears when the system is powered on. Select the mode of operation from the Main page.

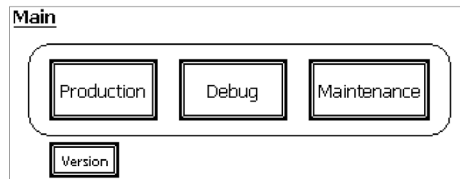

A password is required for both Debug and Maintenance modes. The default password is **1263**. Administrators can change the password by pressing **Change Password** on the password page.

Table 2-1 Modes of Operation

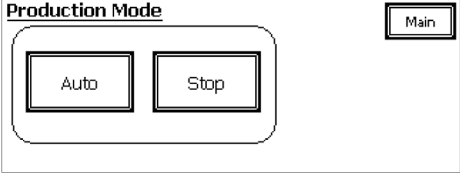
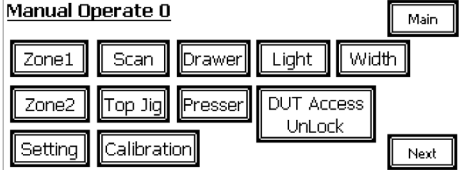
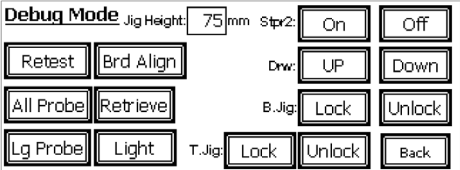
LCD Touch Panel Menus	Description
<p>Production Mode</p> 	<p>Start and stop production testing.</p> <ul style="list-style-type: none"> • Auto – Begin testing in Auto mode. • Stop – Stop operation.
<p>Maintenance Mode</p> 	<p>Calibrate and set up the system for production. The functions are described in Maintenance Mode on page 2-3.</p>
<p>Debug Mode</p> 	<p>Debug Mode provides buttons to quickly move the Press to previously taught positions.</p>

Maintenance Mode

On the LCD panel’s Main page, press **Maintenance** to access Maintenance Mode. A password is required.

In Maintenance Mode, navigation buttons are provided at the right side of the page where needed, as shown in the following examples.

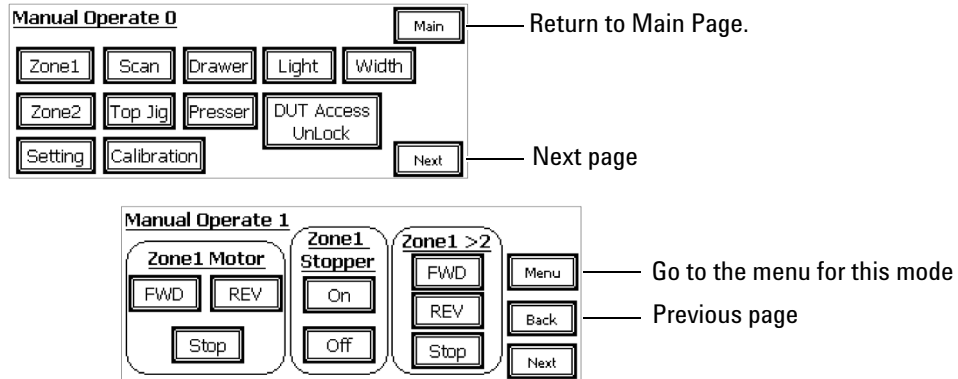

Table 2-2 describes the functions in Maintenance Mode.

Table 2-2 Maintenance

Menu	Option/Description
	<ul style="list-style-type: none"> • Zone 1 • Zone 2 • Scan • Drawer • Top Jig • Presser • Setting – Change various test settings. See Test Settings on page 2-5. • Calibration – Calibrate Press positions. See Learn Press Heights on page 3-22. • Light – Turn the Zone 2 light on or off. • Width – Set the conveyor width. • DUT Access Unlock – Unlock or lock DUT Access window (if present).

Table 2-2 Maintenance

Menu	Option/Description
<p>Zone 1</p> 	<p>Zone 1 Motor FWD – Start forward movement of Zone 1 conveyor. REV – Start reverse movement of Zone 1 conveyor. Stop – Stop Zone 1 conveyor.</p> <p>Zone 1 Stopper On – Move Zone 1 stopper up. Off – Move Zone 1 stopper down.</p> <p>Zone 1 > 2 FWD – Start forward movement of Zone 1 and Zone 2 conveyors. REV – Start reverse movement of Zone 1 and Zone 2 conveyors. Stop – Stop conveyors.</p>
<p>Zone 2</p> 	<p>Zone 2 Motor FWD – Start forward movement of Zone 2 conveyor. REV – Start reverse movement of Zone 2 conveyor. Stop – Stop Zone 2 conveyor.</p> <p>Zone 2 Stopper On – Move Zone 2 stopper down. Off – Move Zone 2 stopper up.</p> <p>Zone 1 > 2 FWD – Start forward movement of Zone 1 and Zone 2 conveyors. REV – Start reverse movement of Zone 1 and Zone 2 conveyors. Stop – Stop conveyors.</p>
<p>Scan</p> 	<p>Scanner Trigger ON – Turn selected scanner on. OFF – Turn selected scanner off.</p> <p>Scanner Front – Select front scanner. Rear – Select rear scanner.</p>
<p>Drawer</p> 	<p>Drawer Lifter Up – Move drawer lifter up. Down – Move drawer lifter down. To move the drawer lifter, the bottom jig clamp must be unlocked.</p> <p>Bottom Jig Clamp Lock – Lock bottom fixture. Unlock – Unlock bottom fixture.</p>

Table 2-2 Maintenance

Menu	Option/Description
<p>Top Jig</p> 	<p>Top Jig Clamp Lock – Lock top fixture Unlock – Unlock top fixture.</p>
<p>Presser</p> 	<p>Presser Up – Move the Press up. Down – Move the Press down. Origin – Move the Press to origin (start) position. Slow – Slow down Press movement. Press again to return to normal speed.</p>

Test Settings

In Maintenance Mode, select **Setting** to access the Setting menus.

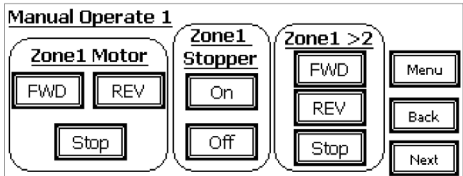
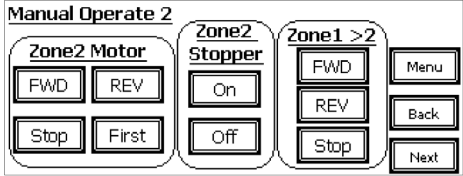
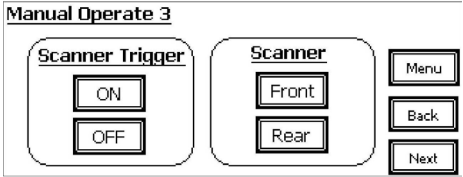
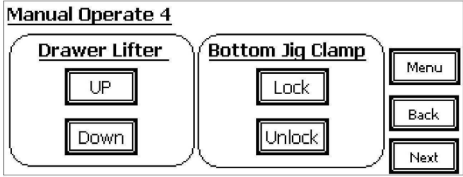
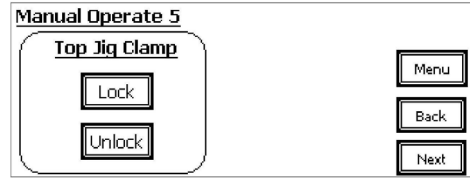
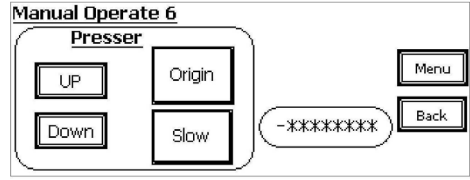
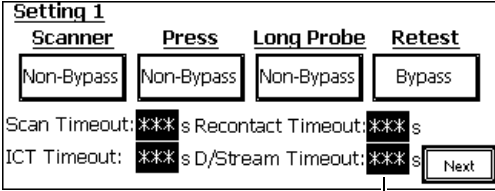

To change any of the values:
 1. Touch the value to display the keypad.
 2. Key in the new value and press **Enter**.

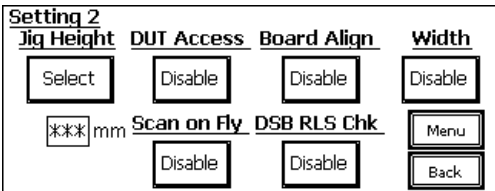

Table 2-3 Settings

Option	Description
Setting 1	
Scanner Press Long Probe Retest	Bypass – Skip the action. Non-Bypass – Perform the action. This is set via the testplan (except for the Press setting).
Scan Timeout	Time (in seconds) to wait for scan result from the controller before triggering an error.
ICT Timeout	Time (in seconds) to wait for test result from the controller before triggering an error.
Recontact Timeout	Time (in seconds) to wait before retest.
D/Stream Timeout	Time (in seconds) to wait for DSB (Downstream Busy) signal from downstream machine. Note: Default timeout = 300 s; minimum 1 s; maximum 999 s.
Setting 2	
Jig Height	Set the jig height to 75 mm, 85 mm or 100 mm.
DUT Access	For systems with optional DUT Access: Enable or disable access to failed boards.
Board Align	Whether to check if the board is seated correctly.
Width	Enable or disable automatic conveyor width control.
Scan on Fly	Whether to scan barcode without stopping the board.
DSB RLS Chk	Downstream Busy signal release check.

Debug Mode

On the LCD panel's Main page, press **Debug** to access Debug Mode. A password is required.

Use Debug mode to quickly move the Press to the various taught positions and check that they are set correctly.

- 1 On the Debug page, press **Origin** to initialize the Press to the start position. Then press **Next** to go to the next page.

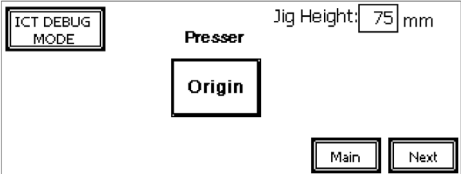

- 2 Press a button on the menu to move the Press to the indicated taught position.

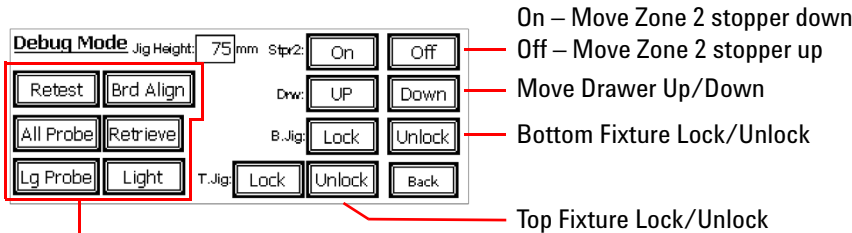

Press a button to move the Press to the indicated taught position.
See [Table 3-5](#).

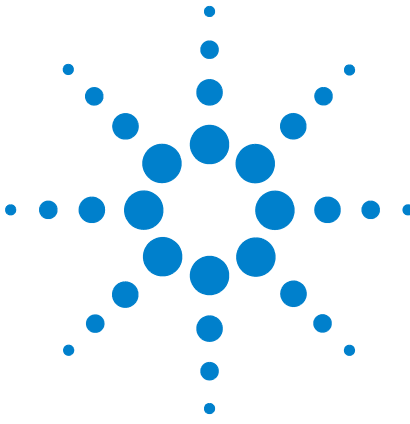

3 Test Development

Test Development Overview 3-2

Fixturing Guidelines 3-3

Fixture Setup and Debugging 3-15

Test Development Overview

Test development on the Medalist i3070 consists of five main tasks listed below. Follow the detailed instructions in the Medalist i3070 online help, which also explains the use of the software tools you can use in each task.

During test development, pay attention to the features and requirements for the Medalist i3070 Series 5i as described in this chapter.

- 1 Gather materials and define test strategy.
- 2 Develop tests and generate fixture files.

During test development, note the following key features for the Medalist i3070 Series 5i.

- **New “IN-LINE” Keyword**

In the board file, a new keyword is introduced for the Medalist i3070 Series 5i inline fixture.

Fixture Type	IN-LINE
Fixture Size	BANK2

- **testmain**

When the IN-LINE keyword is used, the new `testmain_inline` will be used to generate testplans for the Medalist i3070 Series 5i.

- **Fixture Consultant**

When the IN-LINE keyword is used, the graphics display in Fixture Consultant is automatically rotated 90 degrees.

The default placement of the board is at the center of the modules and toward the front edge of the fixture (see [Fixturing Guidelines](#)).

- 3 Build and verify fixture.

Fixture specifications and requirements for the Medalist i3070 Series 5i can be found in [Fixturing Guidelines](#) and [Fixture Setup and Debugging](#) in this chapter.

- 4 Complete and debug tests.
- 5 Release to production.

Fixturing Guidelines

- Board Placement and Specifications
- Bottom Fixture
- Top Fixture
- Guide Pin
- Top Fixture Height After Compression
- ID Block
- Optional Signals

Board Placement and Specifications

The Board Placement task decides the placement of the board on the fixture and creates the fixture files. The placement of the board is specified as X and Y offsets from the fixture origin to the board origin and a rotation angle.

The default placement of the board is at the center of the modules with the edge of the board 28.1 mm from the front edge of the fixture. The keepout area is necessary to avoid blocked resources.

Figure 3-1 Board Placement

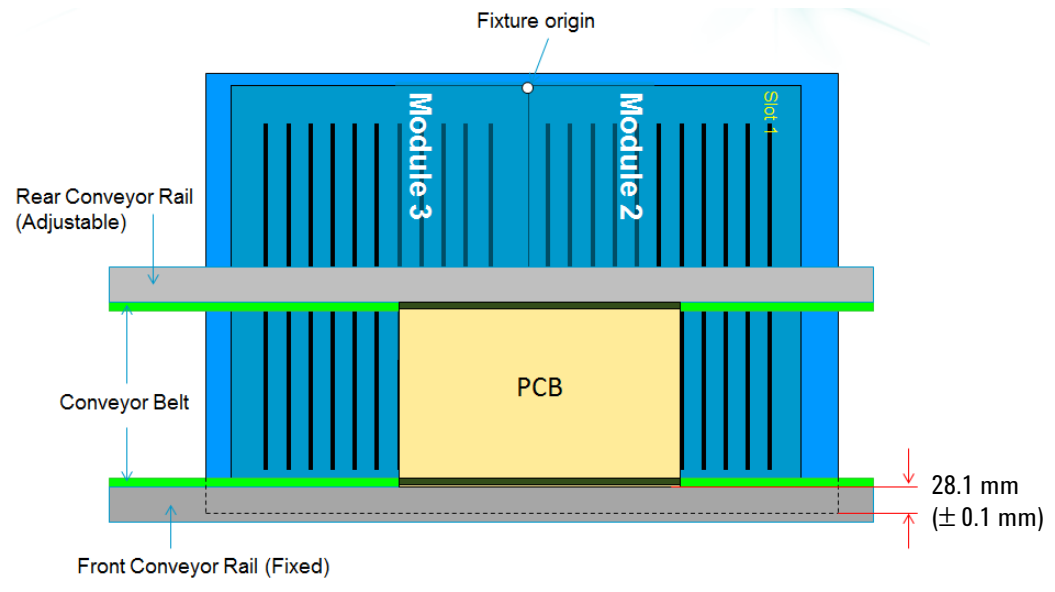
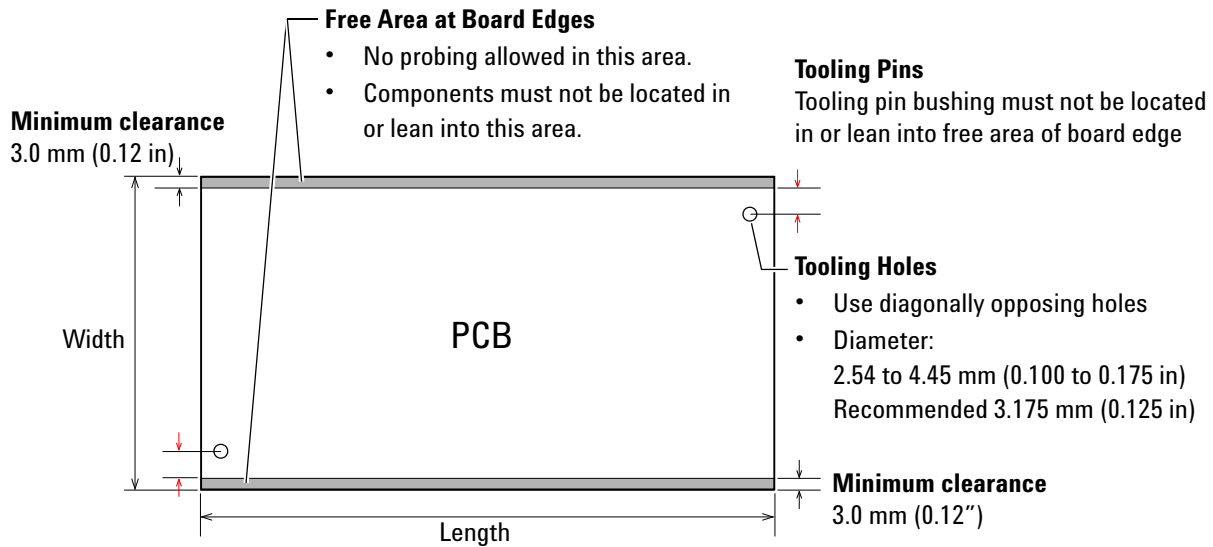

Figure 3-2 Board Specifications



Board Width

Minimum: 60.0 mm (2.36 in)
 Maximum: 350.0 mm (13.8 in) without top side and dual stage probes
 Tolerance: 0.25 mm (0.01 in)

Board Length

Minimum: 50.0 mm (2.36 in)
 Maximum: 350.0 mm (13.8 in) without top side and dual stage probes

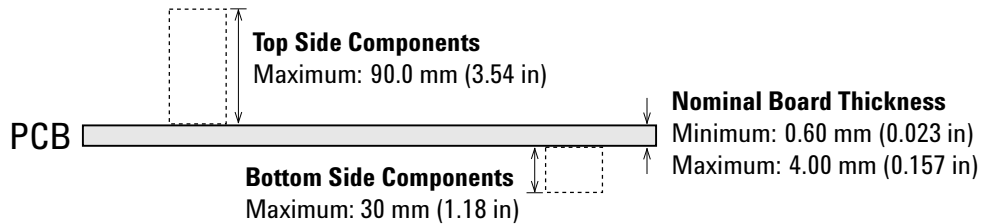

Bottom Fixture

Figure 3-3 Bottom Fixture Specifications

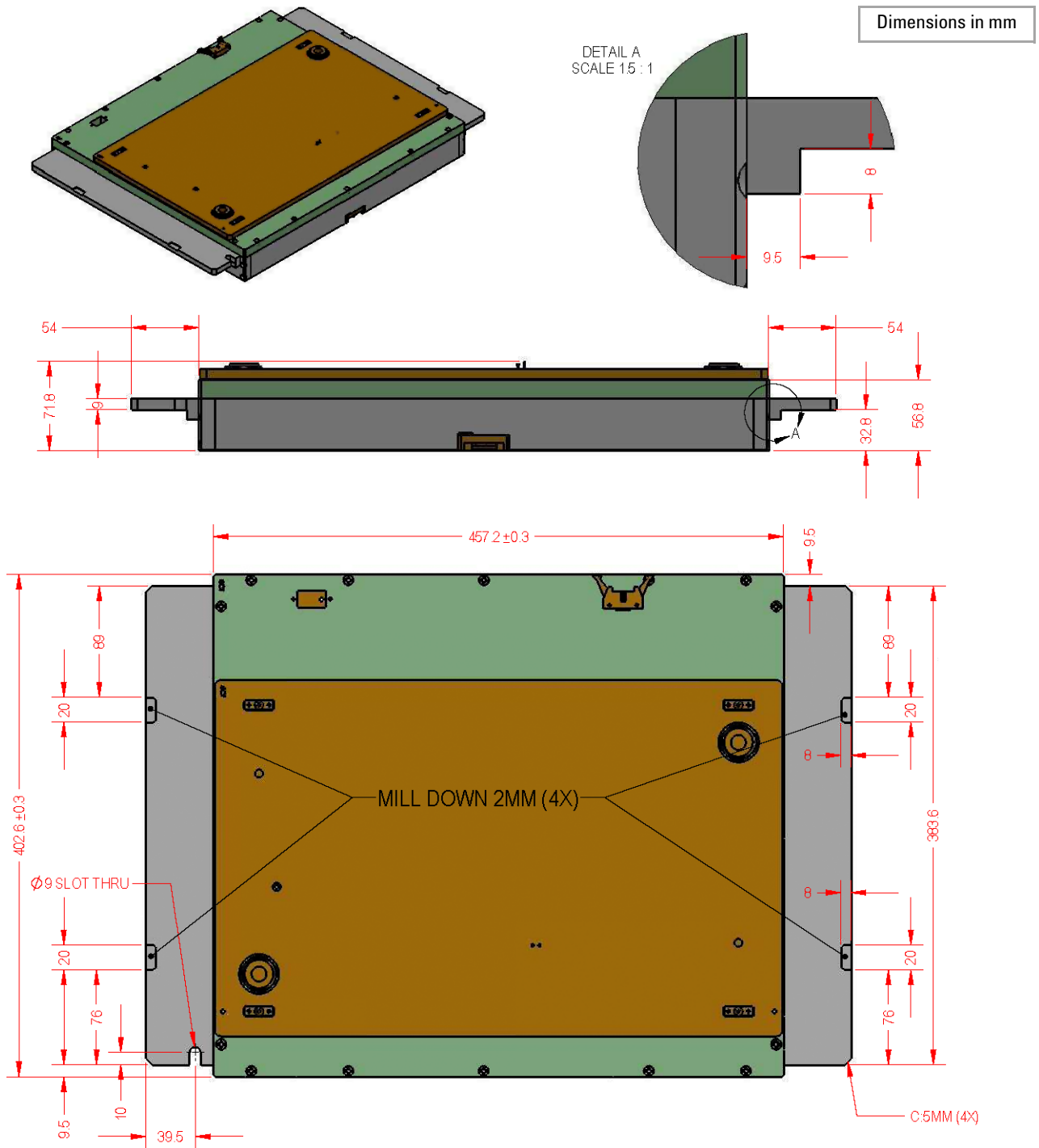

NOTE: All connectors (Board Align, Board Orientation, VTEP and CET control signals) should be placed at the front of the fixture for easy connection and removal when changing the fixture.

Figure 3-4 Bottom Fixture: Maximum Height

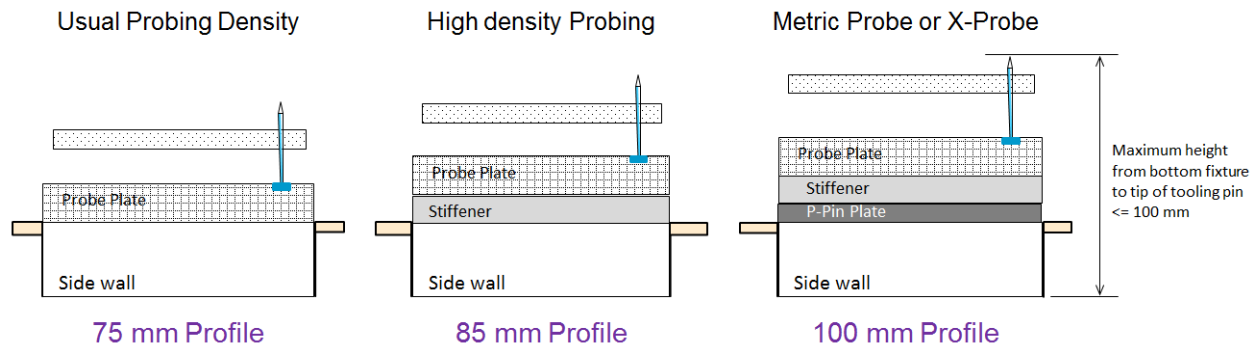
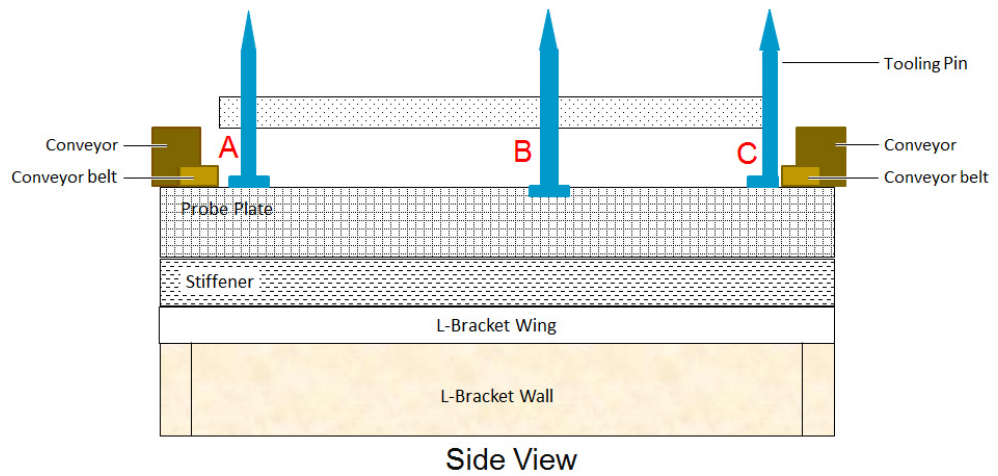

Figure 3-5 Bottom Fixture: Tooling Pin Bushing



A: The tooling pin bushing should not lean into the conveyor belt area.

B: The bushing should be flush with the probe plate.

C: If any part of the bushing interferes with the conveyor, it must be cut away.

Top Fixture

Figure 3-6 Top Fixture Specifications

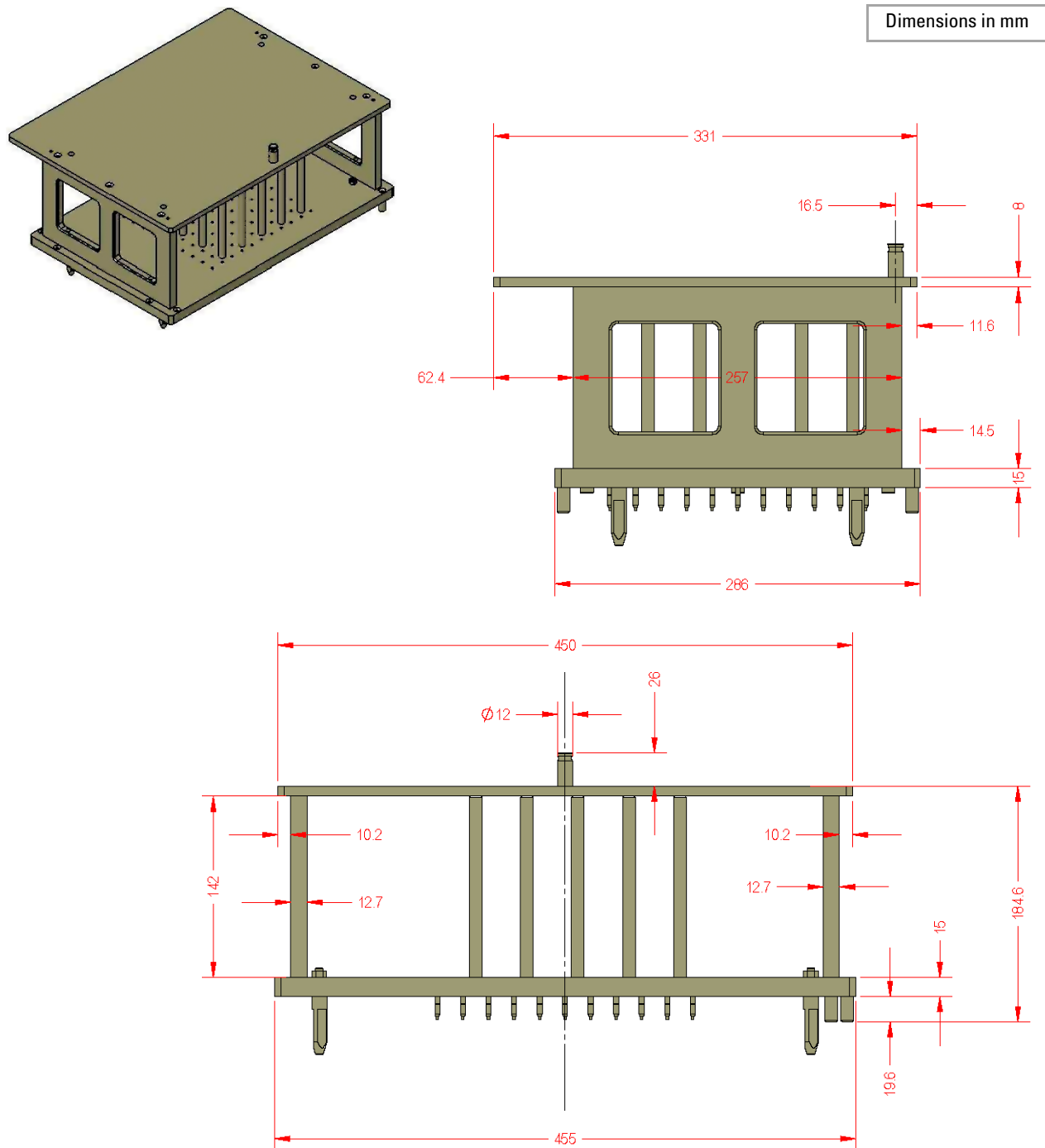

Guide Pin

Figure 3-7 Guide Pin Position

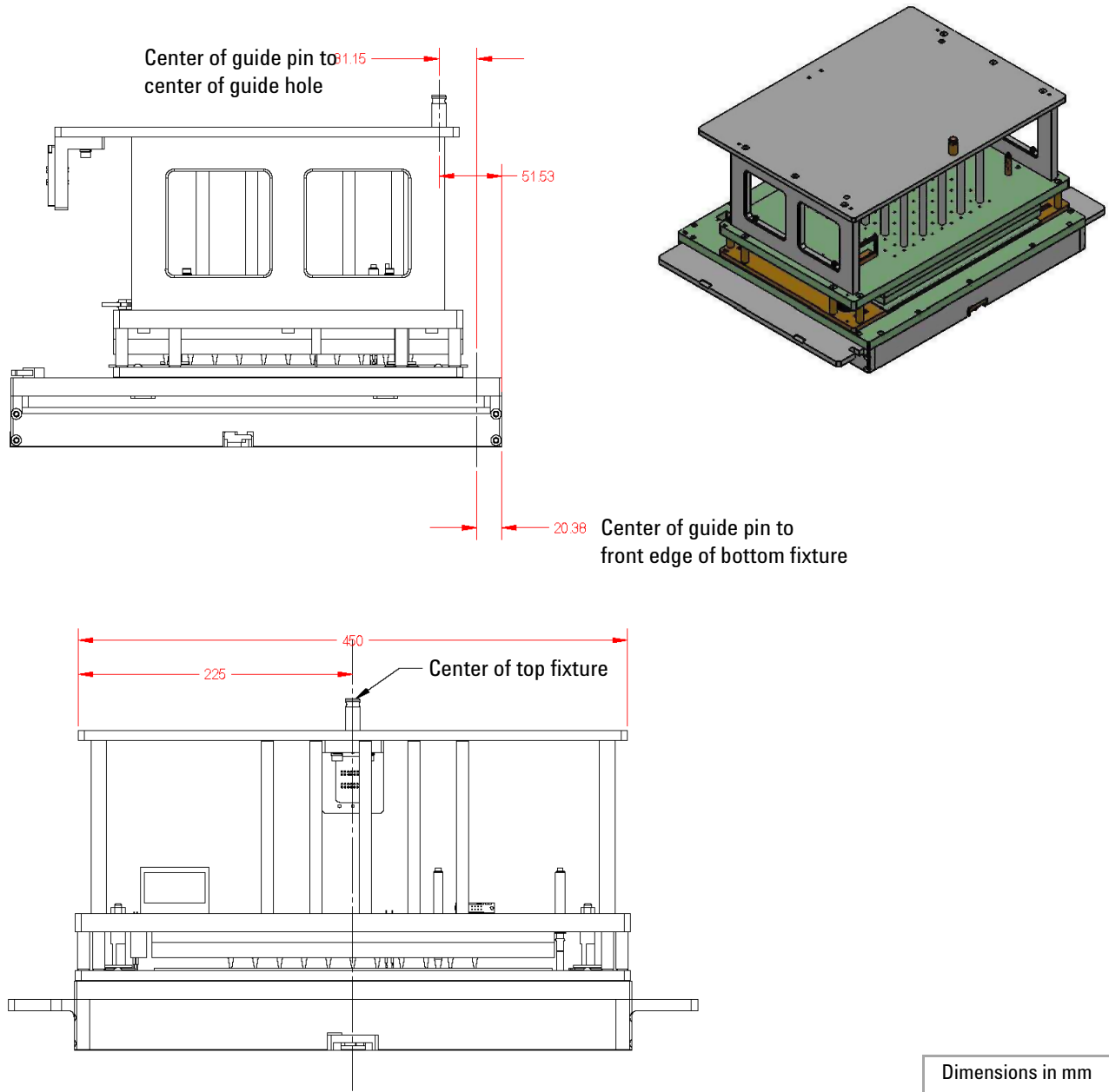

Top Fixture Height After Compression

The overall height from the top plate to the bottom of the PCB must be 184.6 mm (7.27 in) after compression, regardless of the PCB thickness.

Figure 3-8 Top Fixture: Front View After Compression

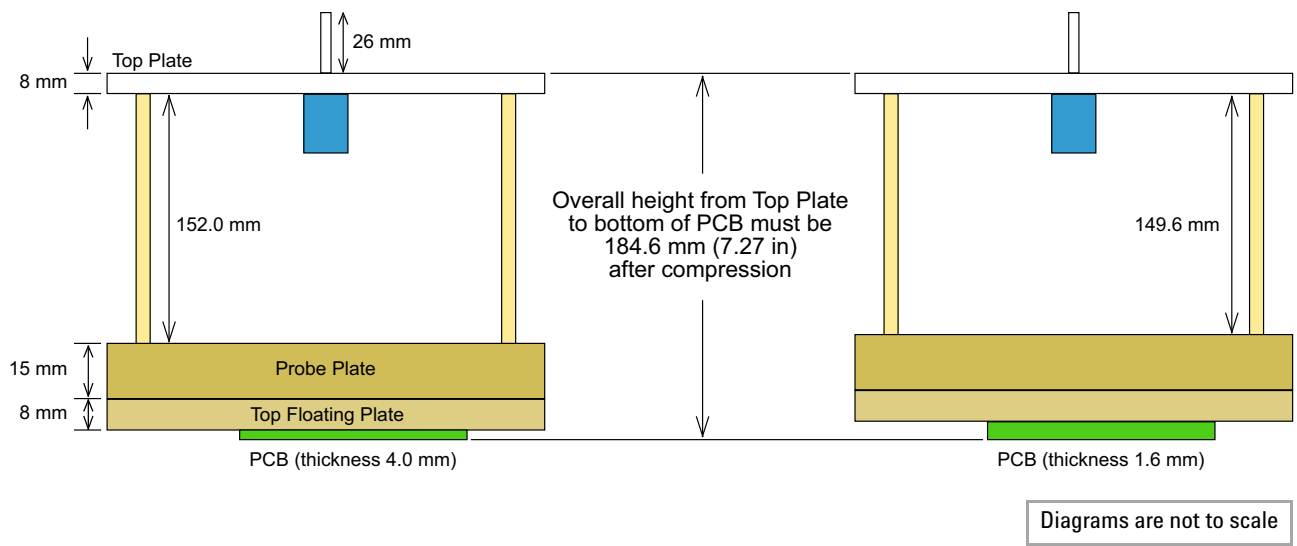

ID Block

The main function of the ID block is to provide the fixture ID for the top fixture. The fixture ID signal (pin 5 to 12 in the first two rows) is used to verify that the top and bottom fixtures match, before the system can go into Production Auto mode.

The ID block has three groups of 16 pins arranged in two rows each, for a total of 48 pins. [Table 3-2](#) shows the pin assignments. The first two rows of pins cannot be reassigned. Rows 3 and 4 (VTEP) and rows 5 and 6 (CET) can be changed.

Figure 3-9 ID Block

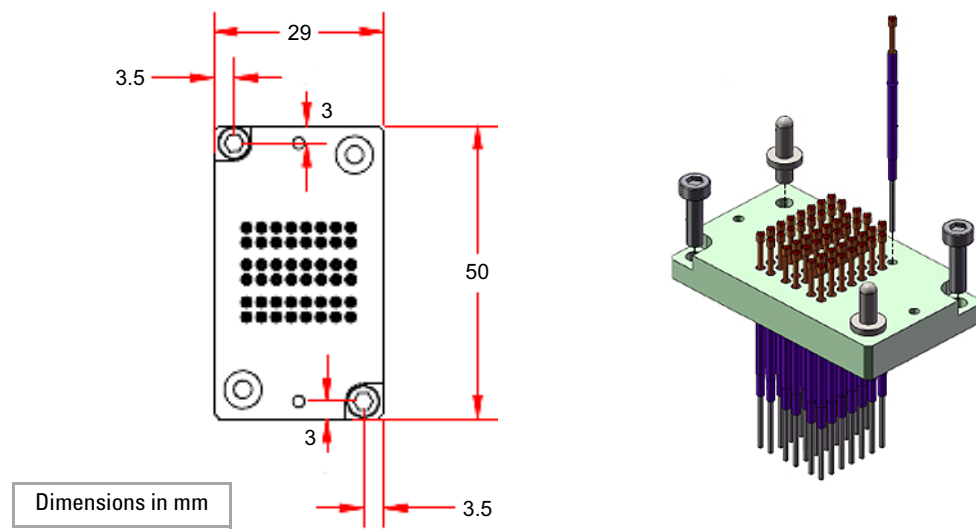

Table 3-1 ID Block: Pinouts

16	14	12	10	8	6	4	2
15	13	11	9	7	5	3	1
16	14	12	10	8	6	4	2
15	13	11	9	7	5	3	1
16	14	12	10	8	6	4	2
15	13	11	9	7	5	3	1

Table 3-2 ID Block: Pin Assignment

Pin 16	Pin 14	Pin 12	Pin 10	Pin 8	Pin 6	Pin 4	Pin 2
AF1 (Signal 404)	AF3 (Signal 406)	AF5 (Signal 408)	AF7 (Signal 410)	AF9 (Signal 412)	AF11(MSB) (Signal 414)	Spare	+ (24V - T) board orientation
Pin 15	Pin 13	Pin 11	Pin 9	Pin 7	Pin 5	Pin 3	Pin 1
AF0 (LSB) (Signal 403)	AF2 (Signal 405)	AF4 (Signal 407)	AF6 (Signal 409)	AF8 (Signal 411)	AF10 (Signal 413)	Auto GND (Signal “-”)	- (Com - T) board orientation
Pin 16	Pin 14	Pin 12	Pin 10	Pin 8	Pin 6	Pin 4	Pin 2
Spare	Spare	Spare	J1.10	J1.8	J1.6	J1.4	J1.2
Pin 15	Pin 13	Pin 11	Pin 9	Pin 7	Pin 5	Pin 3	Pin 1
Spare	Spare	Spare	J1.9	J1.7	J1.5	J1.3	J1.1
Pin 16	Pin 14	Pin 12	Pin 10	Pin 8	Pin 6	Pin 4	Pin 2
Spare	Spare	LEM_M	LEM_R	LEM_A	CET PWR	USB VCC	Data -
Pin 15	Pin 13	Pin 11	Pin 9	Pin 7	Pin 5	Pin 3	Pin 1
Spare	Spare	ASRU SW GND	ASRU SW GND	ASRU SW GND	CET GND	USB GND	Data +

Figure 3-10 ID Block Location

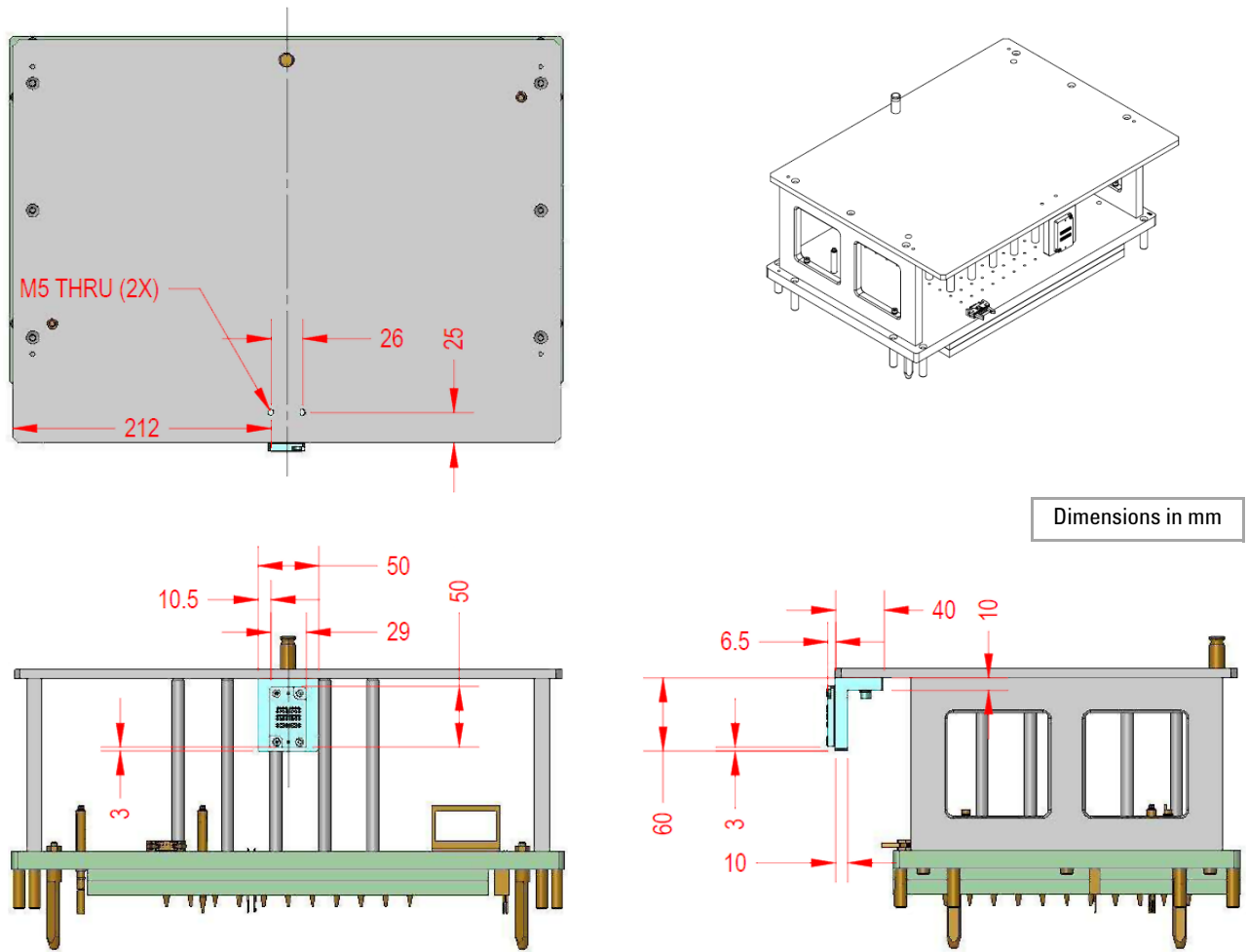

Optional Signals

- Board Orientation
- Board Sit

Board Orientation

An optional Board Orientation signal can be used to verify that:

- the orientation of the board is correct
- the board has stopped at the correct position for testing in Zone 2

This may be achieved by means of a laser beam perpendicular to the board surface. The transmitter and receiver are aligned with a tooling hole of a correctly positioned and oriented board.

As the board travels from Zone 1 to Zone 2, it is detected by the stopper sensor. When the board reaches the board stopper, the system checks for the board orientation signal; if it is detected, the Press is automatically lowered.

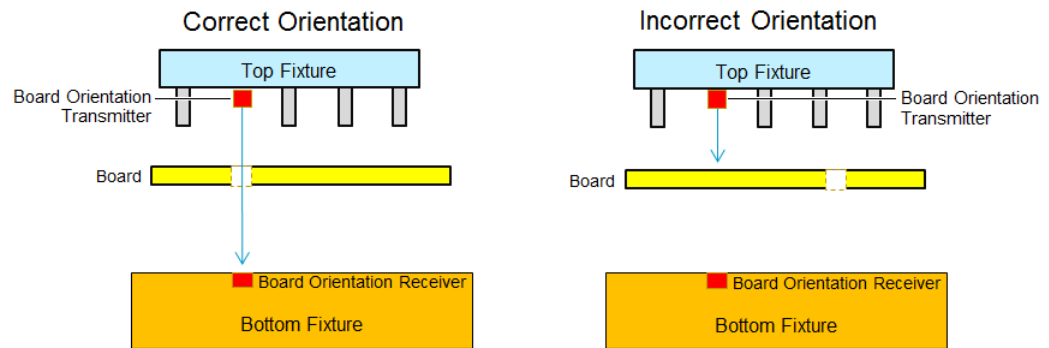

Table 3-3 Board Orientation Laser Thru Beam Sensor

Signal	NPN		
Power	+24V DC		
Sense Distance	300 mm		
Recommendation	Optex (economical), Keyence, Omron		
Connector Pinout (Receiver)	Pin 1	Pin 2	Pin 3
	+ (24DC)	– (Com)	Signal 007 (Board Orientation)

Board Sit

An optional Board Sit signal can be used to verify that the board is sitting flat on the support plate. Dry contact sensors are recommended for this.

Connect the micro switches in series, and connect them to the fixture connector provided, as shown in [Figure 3-11](#). Use Pin 2 and 3 for dry contact (voltage free).

When the board is sitting flat on the support plate, all the switches close and provide a short signal to the PLC input. Once the signal is detected, the Press is lowered to the All Probes position.

Table 3-4 Board Sit Signal

Pin	Signal
1	+ (24DC)
2	– (Com)
3	Signal 315 (Board Sit)

Figure 3-11 Connections for Board Sit Signal

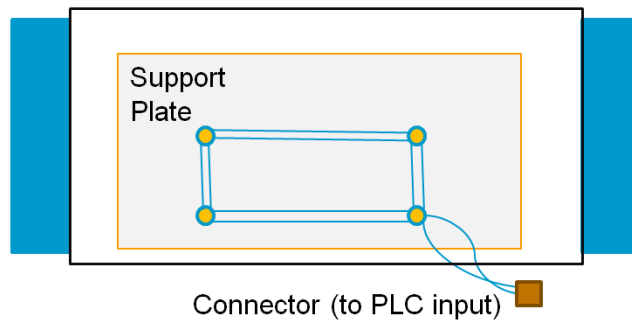

Connector labeled **315** can be found at the front of Zone 1.

Fixture Setup and Debugging

- [Fixture Setup](#)
- [Verify the Fixture](#)

Fixture Setup

Follow the procedures in this section to set up a new fixture.

- 1 [Adjust Conveyor Width](#)
- 2 [Load Bottom Fixture](#)
- 3 [Adjust Board Stopper](#)
- 4 [Learn Press Heights](#)
- 5 [Complete the Setup](#)

Adjust Conveyor Width

The conveyor width can be adjusted using the hand crank or via the LCD touch panel.

CAUTION

Ensure the Maintenance Key Switch is set to ON when adjusting the conveyor.

Using the Crank

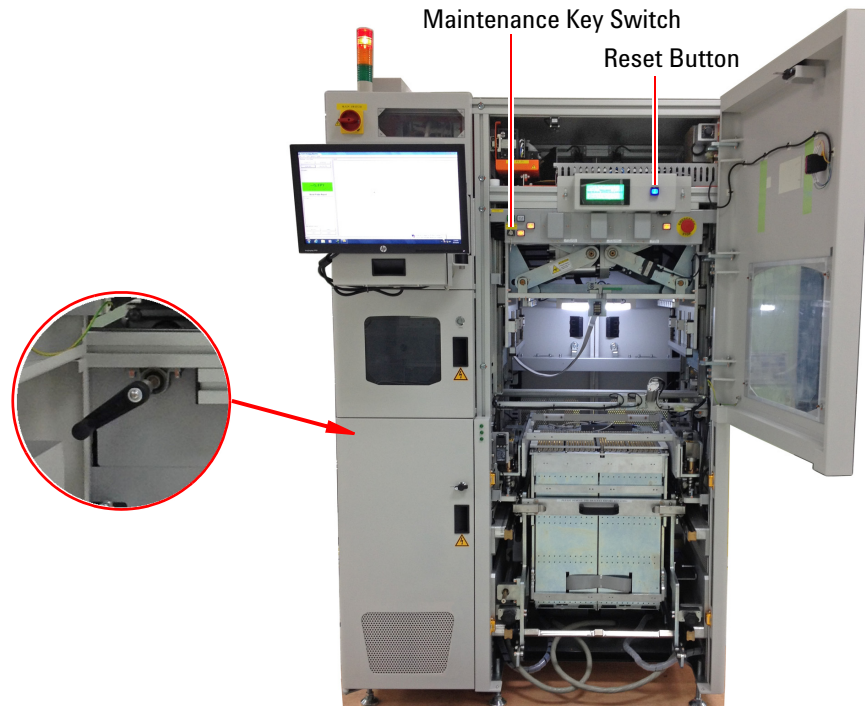

- 1 Open the controller pod and Zone 2 doors. Remove the testhead pod cover.
- 2 On the manual control panel, turn the **Maintenance Key Switch** to ON.
- 3 Insert the crank into the leadscrew. Turn the crank to adjust the conveyor to the required width.

Place a production board on the conveyor and ensure that the board can be transported smoothly from Zone 1 to Zone 2.

Using the Touch Panel

- 1 Select **Maintenance** mode on the **LCD touch panel** and press **Width**.

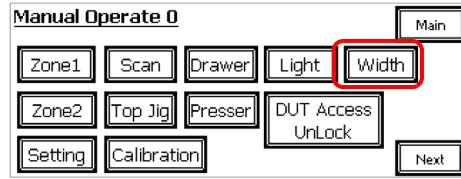

- 2 Press **Next**.
- 3 Enter the board width in mm and then press **Go Pos** to move the conveyor rail to the specified width.

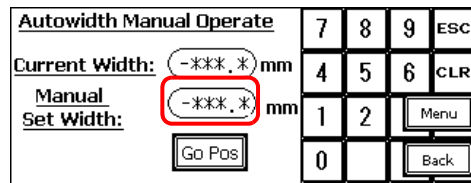

Load Bottom Fixture

- 1 Release the drawer:
 - a Select **Maintenance** mode on the [LCD touch panel](#). Press **Drawer** to go to page 4.
 - b Press **Unlock**, then press **UP** to move the drawer up.

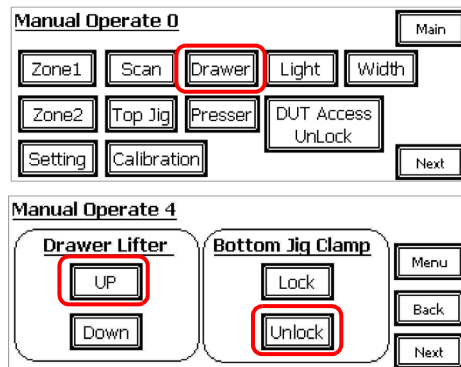

- 2 Pull the drawer out by its handles.

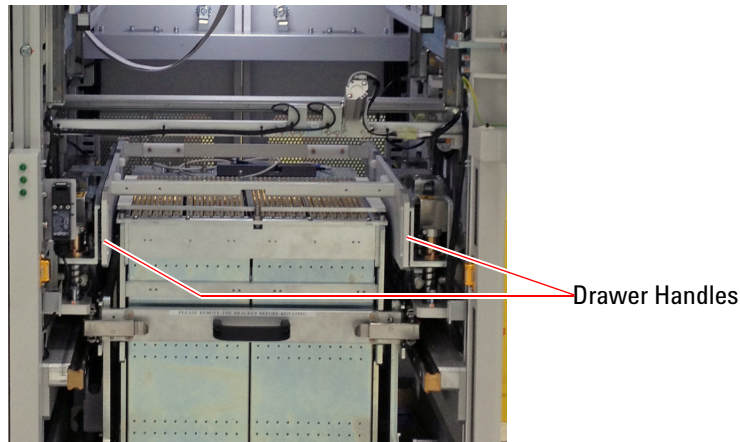

- 3 Load the bottom fixture on the drawer.

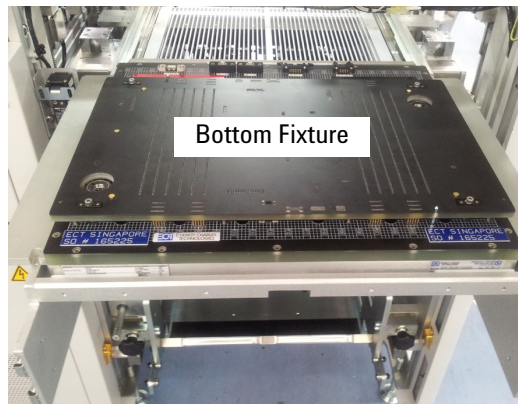

- 4 Push the drawer back.

- 5 On the LCD touch panel, press **Down** to move the drawer down, then press **Lock** to lock the bottom fixture.

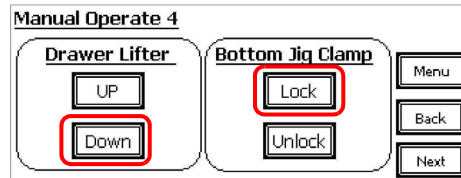

Adjust Board Stopper

The board stopper ensures that the board is stopped at the correct position for testing. Adjust the board stopper using a production board.

- 1 Turn the Zone 2 board stopper on.
 - a On the **Maintenance** menu select **Zone 2** to go to page 2.
 - b Select **On** for the Zone 2 stopper.

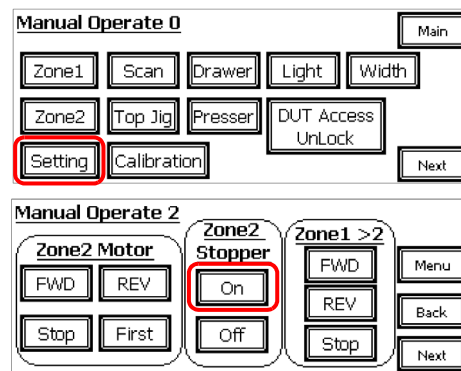

- 2 Place the production board on the fixture support plate.
- 3 Loosen two screws on the board stopper bracket.

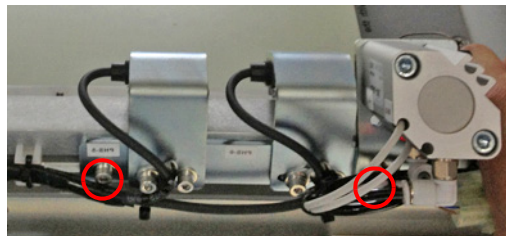

- 4 Push the fixed rail down as you move the board stopper to the edge of the board.
- 5 Tighten the screws on the bracket.
- 6 Place the board on the conveyor and skate it to the board stopper.

- 7 On the LCD touch panel, turn the stopper off.

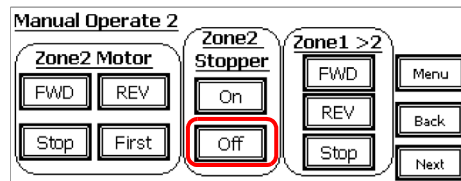

- 8 Go to page 6. Manually jog the Press to check that the board is correctly positioned and can be guided onto the tooling pins.

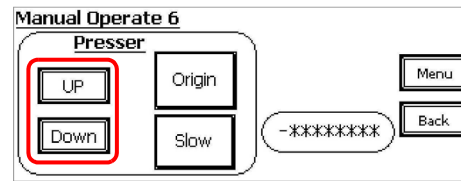

NOTE If necessary, use **Slow** to slow down Press movement during checking.

- 9 Repeat the process to adjust the placement of the board stopper if necessary to ensure the board is stopped at the correct position.
- 10 Load the top fixture.
 - a Slide the top fixture along the rollers into the system.

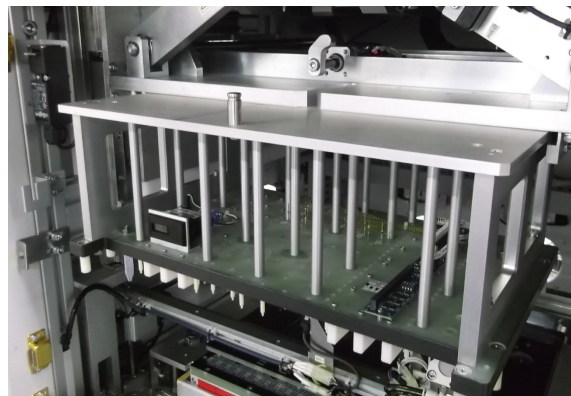

- b On the **Maintenance** menu select **Top Jig** to go to page 6 and select **Lock**.

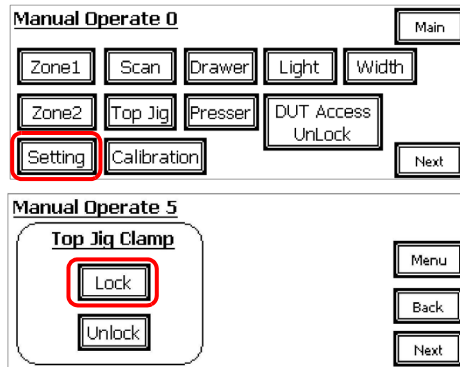

- 11 Go to page 6. Manually jog the Press to check that the board is correctly positioned and can be guided onto the tooling pins.

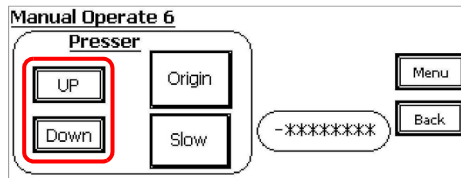

Learn Press Heights

The press positions described in [Table 3-5](#) need to be set according to the fixture/pin design. Follow the procedure below to set these press positions. The taught positions are automatically saved to the 75 mm, 85 mm or 100 mm fixture profile. They need not be set again when reloading the same fixture or another fixture with the same key characteristics.

NOTE

A password is required to access the Calibration pages. Also turn the Maintenance Key Switch to ON.

- 1 In Maintenance Mode, select **Calibration**.

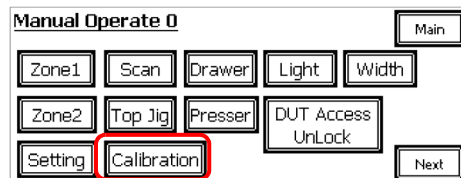

- 2 Press **Origin** to move the Press to the start position.

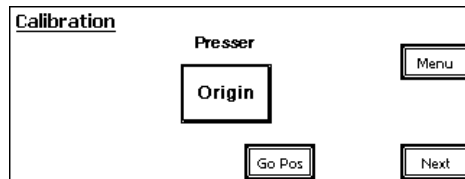

- 3 Press **Next** to continue.
Press **Next** to skip the Standby Pos and Presser Retrieve Pos pages. (That is, keep the factory settings for those positions.)
- 4 Begin calibration with the **Retest Pos**.

NOTE

There are separate calibration pages for the 75 mm, 85 mm and 100 mm fixture. Check the title of the page and make sure it is correct for your fixture.

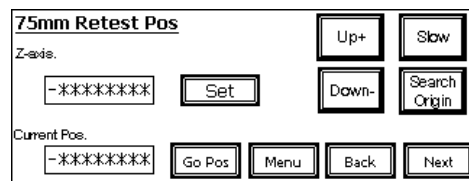

Z-axis shows the saved position.
Current Pos shows the current position as the Press is moved.

- a Press **Search Origin** to move the Press to the start position.
 - b Press **Up+** or **Down-** to move the Press to the desired position.
Use **Slow** to slow down the Press movement if needed.
 - c Press **Set** to save the taught position.
- 5 Press **Next** to learn the next position. See [Table 3-5](#).

Table 3-5 Press Positions

Calibration Option	Press Position
<p>Standby Pos Standby position that allows the transfer of the board from Zone 1 to Zone 2.</p>	
<p>Presser Retrieve Pos Safe position of the Press for removing the fixture or for maintenance.</p>	<p>The three 75 mm fixture calibration pages below will be followed by similar pages for 85 mm and 100 mm. Be sure to use the correct calibration pages for the fixture that is loaded.</p>
<p>75mm Retest Pos Position where the board does not contact any probes.</p>	
<p>75mm All Probe Pos Position where the board is in contact with all probes for analog and digital in-circuit testing.</p>	

Table 3-5 Press Positions

Calibration Option	Press Position
<p>75mm Jig Long Probe Pos Position where the board is in contact with the long probes only, for dual stage testing.</p>	
<p>75mm Board Align Pos Standby position while verifying that the board is seated properly on the tooling pin and support plate.</p>	

- When finished, press **Next** to check the taught positions using the **Presser Go Position** pages.

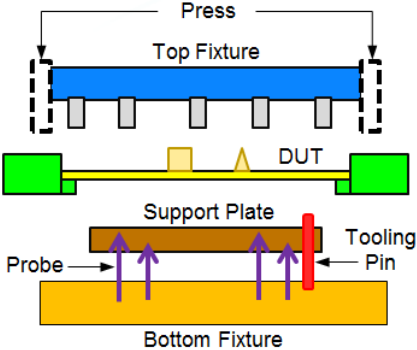
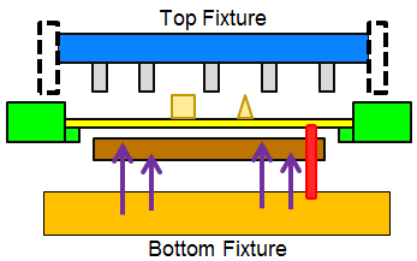
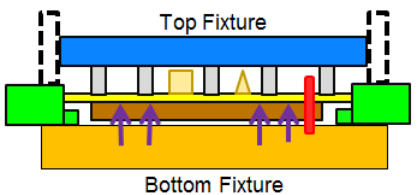

Press a button and verify that the Press moves to the taught position.

Complete the Setup

- Turn the **Maintenance Key Switch** to OFF.
- Close all the doors and covers.
- Press the **Reset** button.
- On the LCD touch panel Main page, select **Production**.

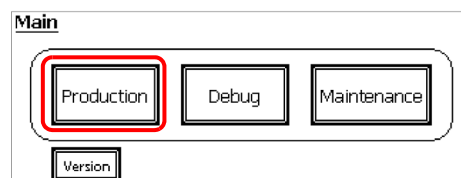

Verify the Fixture

- Use Pushbutton Debug to verify the fixture as described in the Medalist i3070 online help.
- Use Debug mode on the touch panel to quickly check the press positions for the fixture. See [Debug Mode](#) on page 2-7.

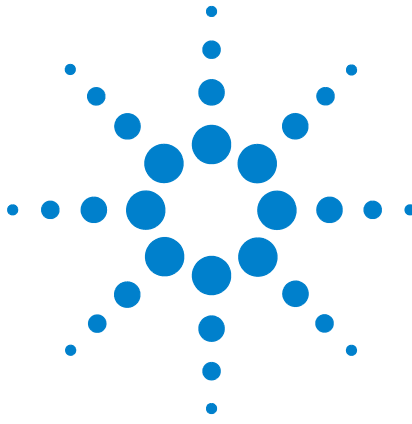

4 Production Setup and Testing

Production Setup 4-2

Production Testing 4-3

Production Setup

Follow these setup procedures on the Medalist i3070 Series 5i whenever there is a change in board model for production.

- 1 [Adjust Conveyor Width.](#)
- 2 [Load Bottom Fixture.](#)
- 3 [Adjust Board Stopper.](#)
- 4 Select Fixture Profile.
 - a Select **Maintenance** mode on the touch panel and enter the password.
 - b Press **Setting** and then **Next**.
 - c On the Setting 2 page, select the **Jig Height** for this fixture (75 mm, 85 mm, or 100 mm).
 - d Load a golden board to check the press positions.
- 5 [Complete the Setup.](#)

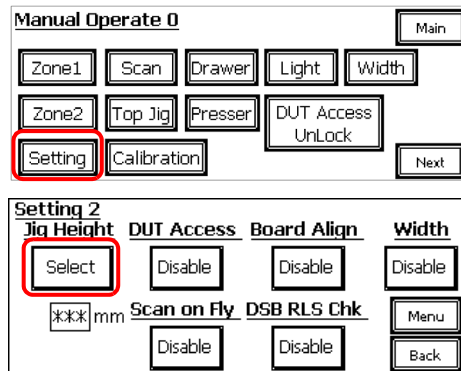

- d Load a golden board to check the press positions.

- 5 [Complete the Setup.](#)

Production Testing

- 1 On the LCD touch panel, select **Production** mode.

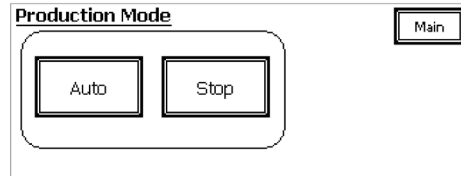

- 2 Launch the Medalist i3070 software.
- 3 Load and run the testplan.
 - When the testplan starts, communication is established between the controller and PLC.
 - Settings are verified and the fixture ID is read.
 - The Press is initialized.
 - On the touch panel, Production mode is automatically set to **Auto** and the system is ready to receive a board and begin testing.

Use the Engineer Test Interface for test debugging when needed.

NOTE

Using the **Break** key on the keyboard will stop the testplan. In case communication with the controller is lost, press and hold **Stop** on the LCD touch panel to stop the testplan running.



5 Maintenance

Calibration 5-2

General Cleaning 5-3

Lubrication Procedures 5-4

Calibration

All Medalist i3070 ICT systems have been tested and calibrated by Agilent Technologies to ensure that all warranted specifications are met at the time of shipment.

For ongoing calibration and performance verification:

- ASRU Calibration – Agilent recommends that the ASRU Card in every module of a Medalist i3070 ICT system be calibrated once every six months.

This procedure calibrates several voltage references and a resistance reference on the ASRU Card. These references are then used to automatically derive all other AutoAdjust correction constants. The system Diagnostics and AutoAdjust routines constitute an overall system operational verification. The ASRU calibration is the only calibration required for the system to continue performing at system specifications.

- System Calibration – In addition to the ASRU calibration, a System Calibration Service is available for customers who desire more comprehensive measurements and reporting. System Calibration should be performed every six months.

This service uses a BT-BASIC program and a traceable voltmeter and frequency counter to measure a DC voltage source at 20 voltages, an AC voltage source at nine voltages, a resistor, and two oscillator frequencies.

These measurements are the foundation for all analog measurements and digital timing. These same parameters are also measured using the internal detectors in the testhead, and the measurements are compared to the standards set by the voltmeter and frequency counter to calibrate the detectors. A report is generated containing the measurement and uncertainty data.

A Pin Verification Fixture (PVF, part number E9988-67901) is required for the calibration procedure. For detailed information about the requirements and calibration procedures, refer to *Calibration* in the Medalist i3070 online help.

General Cleaning

The importance of cleanliness cannot be overemphasized. Dirt in the testhead will cause contact problems and overheating.

- MINT pins (fixture interface pins) – Dirt will cause high-impedance contacts and pin sticking.
- Pin cards, mother cards and vents – Air flow through the system causes a buildup of dirt on pin cards and Mother Cards and clogs air vents in the testhead, contributing to system overheating. Check and clean these areas as necessary.
- Test fixtures – When not used, test fixtures should be stored in a clean environment such as a closed cabinet or carousel. Check and clean as necessary.
- Keep a Pin Verification Fixture or dust cover(s) on the testhead whenever a fixture is not in place.
- System covers – Clean with a water moistened cloth when necessary. Do not use cleaning solutions.

Lubrication Procedures

Maintenance Schedule

It is recommended that the following parts be checked and lubricated monthly:

- Press: Ballscrew and Ballscrew Nut
- Press: Linear Shafts
- Press: Runner Blocks
- Zone 1 Conveyor: Leadscrew and Spline Shaft
- Zone 1 Conveyor: Bevel Gears and Chain
- Zone 2 Conveyor: Runner Blocks
- Drawer: Guide Shafts
- Testhead: Spur Gears

Tools and Supplies

- Brush for greasing parts such as the leadscrews, shafts, and chains.
- Grease gun with circular adapter head and tapered adapter head for the ballscrew nut and runner block respectively. Fit the adapter head into the nipple head of the part to be lubricated.

Press: Ballscrew and Ballscrew Nut

- 1 Open the Zone 2 door to access the Press.

The ballscrew and ballscrew nut are found at the side of the Press.

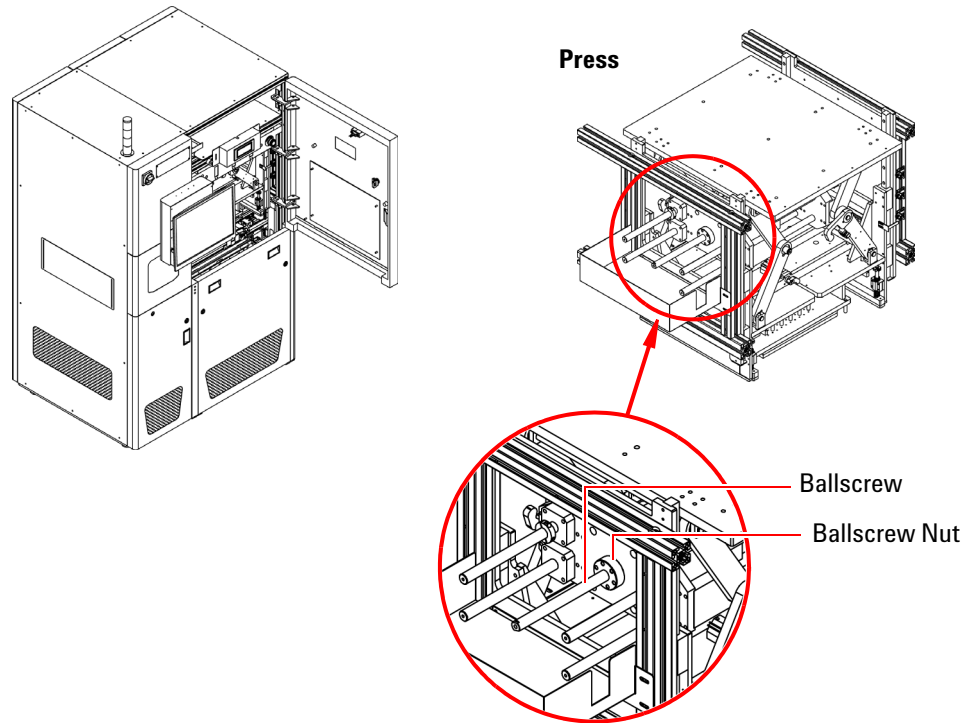

- 2 Use a grease gun to apply a small amount of grease as shown below.

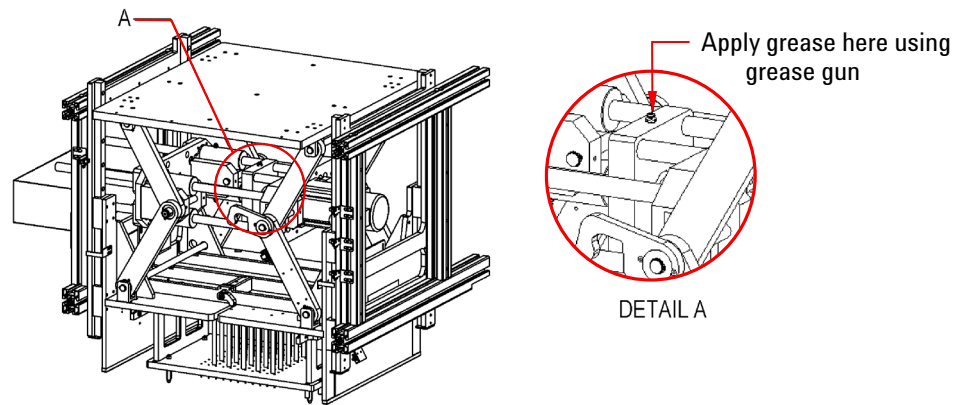

- 3 Close the door.

Press: Linear Shafts

The Press has four linear shafts.

- 1 Open the Zone 2 door to access the Press.

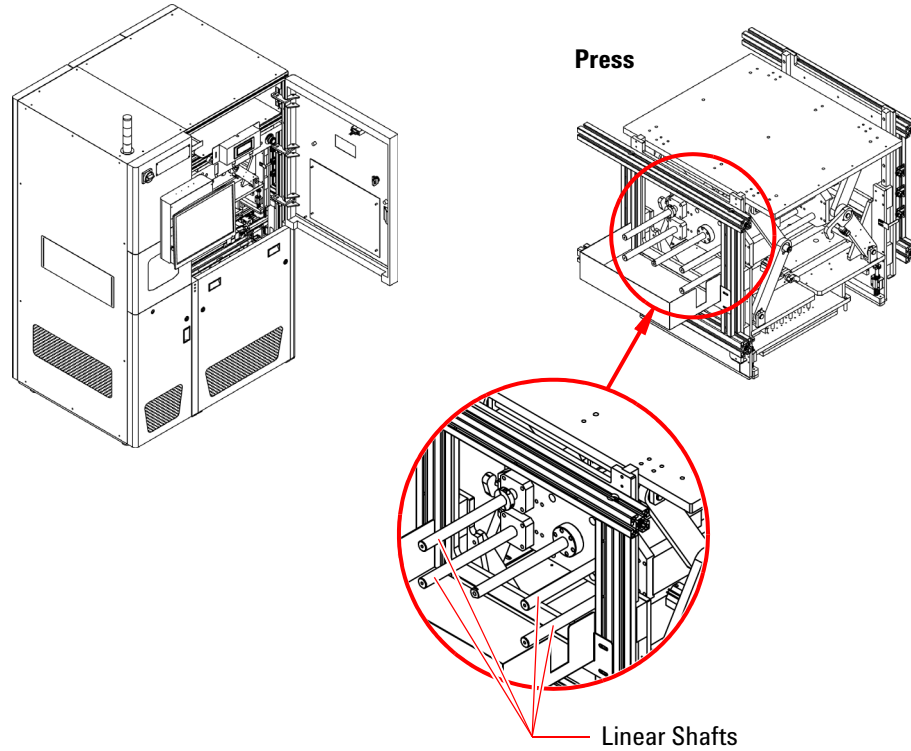

- 2 Use a grease gun to apply a small amount of grease to the four linear shafts.

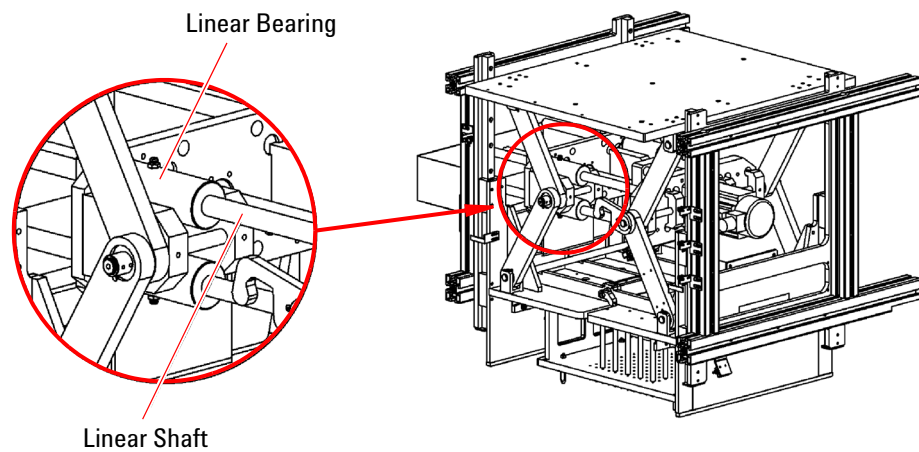

- 3 Close the door.

Press: Runner Blocks

The Press has vertical guide rails at the four corners, with two runner blocks along each rail.

- 1 Open the Zone 2 door to access the Press.

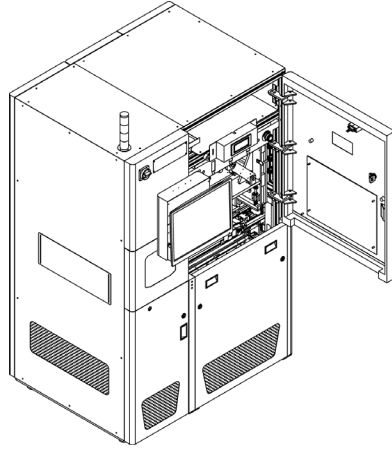

- 2 Use a grease gun to apply a small amount of grease to the four runner blocks at the front.

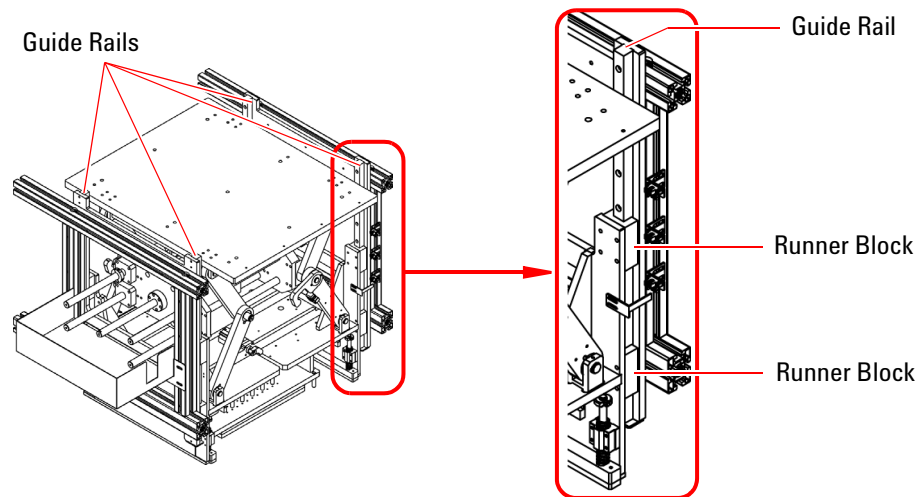

- 3 Open the rear doors to lubricate the four runner blocks at the rear.
- 4 Close the doors.

Zone 1 Conveyor: Leadscrew and Spline Shaft

- 1 Open the Zone 1 door to access the Zone 1 conveyor assembly.

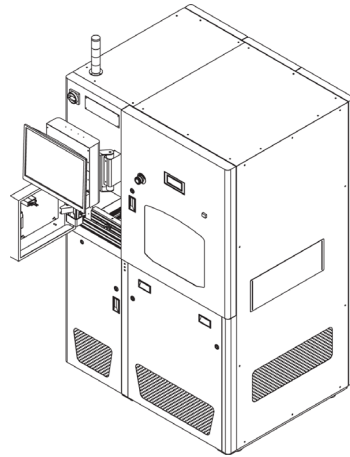

Zone 1 Conveyor Assembly

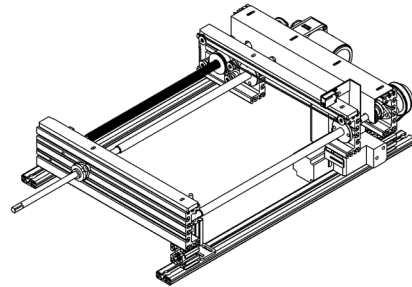

- 2 Use a brush to lightly apply grease to the two leadscrews and the spline shaft.

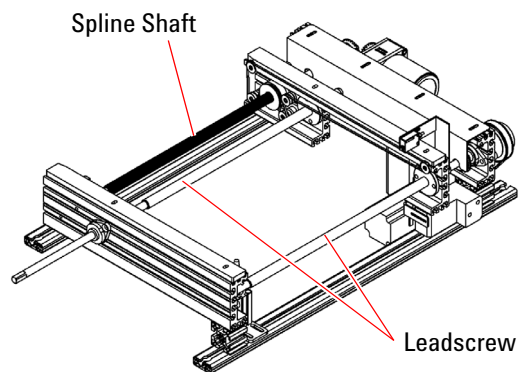

- 3 Close the door.

Zone 1 Conveyor: Bevel Gears and Chain

- 1 Open the rear door to access the Zone 1 conveyor assembly.

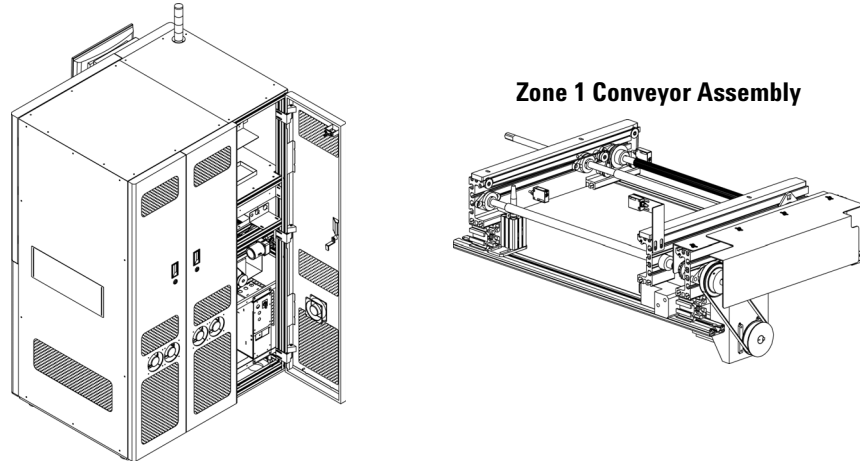

- 2 Remove three screws to remove the rear cover of the assembly.

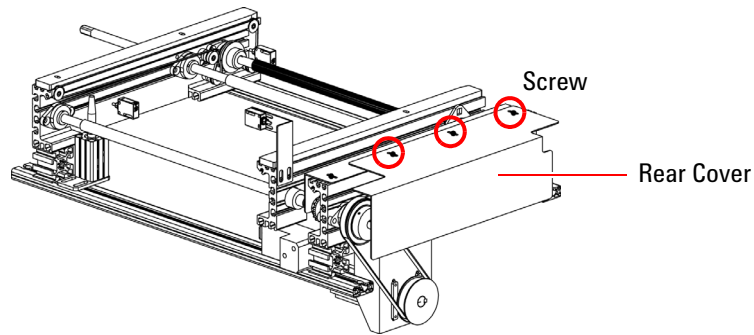

- 3 Use a brush to lightly apply grease to the two bevel gears and the chain.

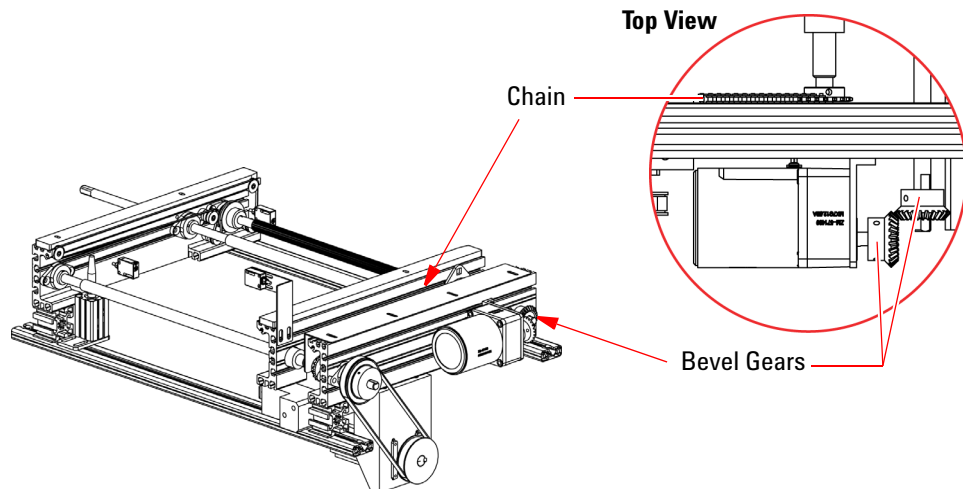

- 4 Replace the rear cover.
- 5 Close the rear door.

Zone 2 Conveyor: Runner Blocks

The Zone 2 conveyor has two horizontal runner blocks and four vertical runner blocks.

- 1 Open the rear doors to access the Zone 2 conveyor assembly.

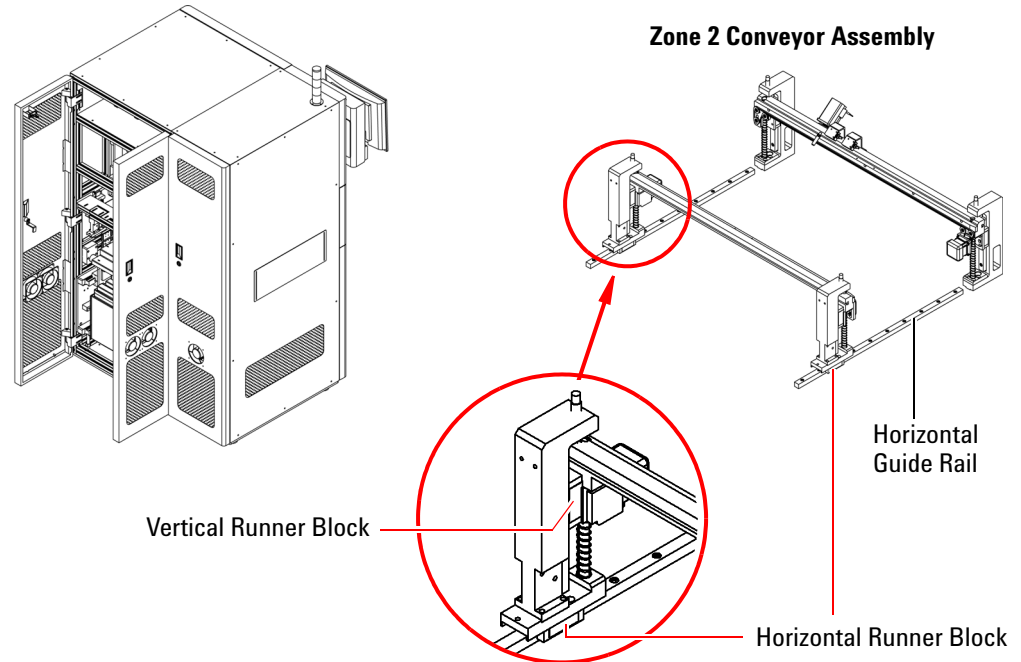

- 2 Use a grease gun to apply a small amount of grease to the runner blocks.
- 3 Close the rear doors.

Drawer: Guide Shafts

The drawer assembly has four guide shafts at the corners.

- 1 Remove the testhead pod cover to access the guide shafts of the drawer assembly.

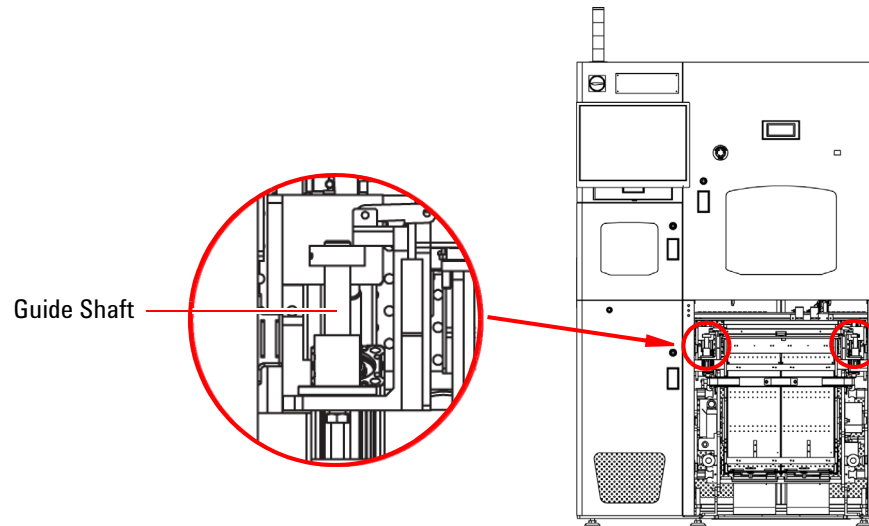

- 2 Use a brush to lightly apply grease to the two guide shafts at the front.
- 3 Open the rear doors to lubricate the two guide shafts at the rear.
- 4 Close the doors.

Testhead: Spur Gears

Power must be connected to begin this procedure.

- 1 Follow [step 1](#) through [step 4](#) in [Accessing the Testhead](#) to pull out the testhead.
- 2 Remove six screws around the spur gear cover.
- 3 Use a brush to lightly apply grease to the two spur gears.

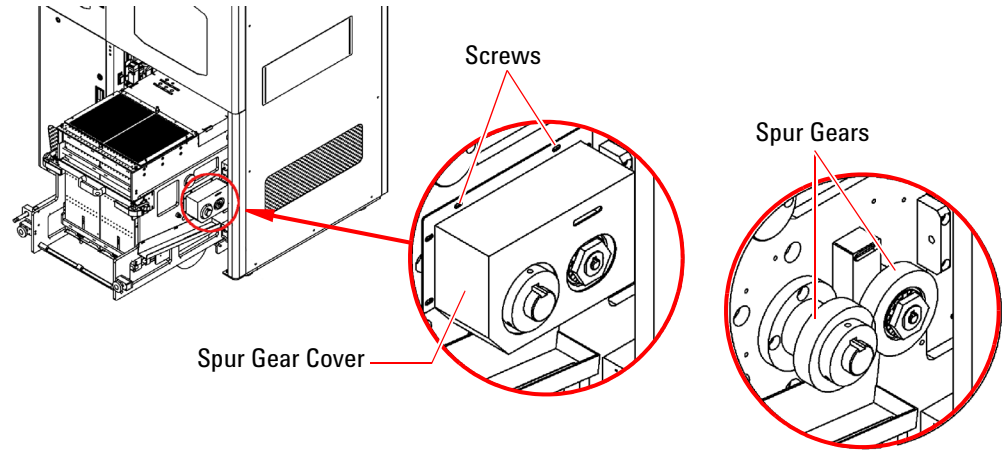

- 4 Replace the guide bar on the testhead and fasten the latches.
- 5 Push the testhead back into the system and tighten the star knobs.
- 6 Close the cover.



6 Troubleshooting

System Diagnostics [6-2](#)

General System Troubleshooting [6-3](#)

Sensor Calibration and Troubleshooting [6-8](#)



System Diagnostics

Diagnostics (dgn) is the main troubleshooting tool. You can use it to check the hardware configuration, verify performance, and isolate failures to a field-replaceable unit (FRU). The Diagnostic tests are structured in such a way that the failing part is usually indicted by the first few test failures.

Some Diagnostic tests require that a Pin Verification Fixture (PVF, part number E9988-67901) be installed on the testhead; other tests require that it not be installed. The Diagnostics program senses whether a fixture is installed or not and automatically runs the appropriate tests.

Refer to *Diagnostics* in the Medalist i3070 online help for information on the Diagnostics software package, how to run it, what the tests are and how to use them for troubleshooting.

General System Troubleshooting

Tower Light Indications

When lit, the tower light color indicates the current status of the system.

Table 6-1 Tower Lights

Light		Possible Conditions
Green	On	System is in Auto mode
Amber	On	<ul style="list-style-type: none"> System has stopped System is in Maintenance mode or Debug mode
	Flashing	<ul style="list-style-type: none"> Error during Maintenance mode Downstream Not Ready timeout
Red	On	<ul style="list-style-type: none"> Emergency Stop activated A door is open when the system is in Auto mode
	Flashing	<ul style="list-style-type: none"> ICT timeout Barcode timeout Retest timeout For systems with DUT Access: <ul style="list-style-type: none"> Bad board waiting in board area (the buzzer will sound) DUT Access window is open

Error Messages and Remedial Actions

If error messages appear on the LCD touch panel, press **OK** and take action as described in [Table 6-2](#).

Table 6-2 Error Messages

Error Message	Cause/Action
Emergency Stop (EMO) Activated Deactivate EMO and RESET button to proceed	<ol style="list-style-type: none"> 1 Release the Emergency Stop switch by turning it clockwise. 2 Press the Reset button.
Door(s) Opened Close the door(s) and RESET button to proceed	<ol style="list-style-type: none"> 1 Close the door(s) and press Reset.
Unable to turn ON Zone 1 Stopper Check stopper reed switch sensor	<ol style="list-style-type: none"> 1 Check that the air supply is turned on. 2 Check the Zone 1 stopper cylinder and replace if faulty. 3 Check the Up reed switch for the Zone 1 stopper (RS-1) and adjust if needed. 4 Replace the Up reed switch if faulty.
Unable to turn OFF Zone 1 Stopper Check stopper reed switch sensor	<ol style="list-style-type: none"> 1 Check that the air supply is turned on. 2 Check the Zone 1 stopper cylinder and replace if faulty. 3 Check the Down reed switch for the Zone 1 stopper (RS-2) and adjust if needed. 4 Replace the Down reed switch if faulty.
Unable to Turn ON Zone 2 Stopper Check stopper reed switch sensor	<ol style="list-style-type: none"> 1 Check that the air supply is turned on. 2 Check the Zone 2 stopper cylinder and replace if faulty. 3 Check the Up reed switch for the Zone 2 stopper (RS-19) and adjust if needed. 4 Replace the Up reed switch if faulty.
Unable to Turn OFF Zone 2 Stopper Check stopper reed switch sensor	<ol style="list-style-type: none"> 1 Check that the air supply is turned on. 2 Check the Zone 2 stopper cylinder and replace if faulty. 3 Check the Down reed switch for the Zone 2 stopper (RS-20) and adjust if needed. 4 Replace the Down reed switch if faulty.
Board Jammed at Zone 1 Conveyor Remove the board manually	<p>If a board could not be moved, the error message will show the location of the jam.</p> <ul style="list-style-type: none"> • Remove the board from the indicated location.
AUTO Mode Error Push RETRIEVE button to lift up the Press and remove board	<p>A board is present when the system tries to start Auto mode operation.</p> <ol style="list-style-type: none"> 1 Manually move the Press to its origin position. 2 Remove the board from the system.
AUTO Mode Error Turn OFF maintenance key and restart testplan	<p>The Maintenance Key Switch is ON when the system tries to start Auto mode operation.</p> <ol style="list-style-type: none"> 1 Turn the Maintenance Key Switch to the OFF position. 2 Restart the testplan.

Table 6-2 Error Messages

Error Message	Cause/Action
<p>Unable to Move Press Clamp bottom jig or check reed switch sensor</p>	<ol style="list-style-type: none"> 1 Install the bottom fixture if it is not present. 2 Check that the air supply is turned on. 3 Check the clamping cylinders and replace if faulty. 4 Check the reed switches on the fixture's locking cylinders (front: RS-5 and RS-7; rear: RS-7 and RS-9). They should not turn on when the bottom fixture is clamped. Replace if faulty.
<p>Unable to Move Press Clamp top jig or check reed switch sensor</p>	<ol style="list-style-type: none"> 1 Install the top fixture if it is not present. 2 Check that the air supply is turned on. 3 Check the locking cylinder for the top fixture and replace if faulty. 4 Check the reed switch on the fixture's locking cylinder (RS-3). It should not turn on when the top fixture is clamped. Replace if faulty.
<p>Top Jig Not Detected Check top jig gap sensor</p>	<ul style="list-style-type: none"> • Check the Top Jig Detect Fully In Detect sensor (PHS-19). • Ensure that the top fixture is installed properly.
<p>Drawer Not Detected Check drawer gap sensor</p>	<ul style="list-style-type: none"> • Check the Bottom Jig Fully In Detect sensor (PHS-11). • Ensure that the drawer is pushed all the way into the system.
<p>Card Cage Not Detected Check card cage detection sensor</p>	<ul style="list-style-type: none"> • Check the Engine Fully In Detect sensor (PHS-9). • Ensure that the testhead is pushed all the way into the system.
<p>Unable to Re-cycle Press Check Press re-contact feedback to PLC</p>	<ul style="list-style-type: none"> • Check the re-contact feedback to PLC .
<p>Zone 2 Motor Driver Error Check motor connection and driver power</p>	<ul style="list-style-type: none"> • Check the Zone 2 motors and driver.
<p>AUTO Mode Error Ensure DUT Access is locked</p>	<p>For systems with optional DUT access feature enabled.</p> <ul style="list-style-type: none"> • Ensure that the Zone 2 door is locked.
<p>Board Not Sitting Correctly Check board alignment and board sit sensor</p>	<p>For systems with optional Board Sit feature implemented.</p> <ul style="list-style-type: none"> • Check the board alignment at Zone 2 conveyor.
<p>Unable to Move Drawer UP Check gap sensor</p>	<ol style="list-style-type: none"> 1 Check that the air supply is turned on. 2 Check the drawer cylinders and replace if faulty. 3 Check the drawer Up sensors (PHS-20 and PHS-22). They should turn on when the drawer is moved up. Replace if faulty.
<p>Unable to Move Drawer DOWN Check gap sensor</p>	<ol style="list-style-type: none"> 1 Check that the air supply is turned on. 2 Check the drawer cylinders and replace if faulty. 3 Check the drawer Down sensors (PHS-21 and PHS- 23).They should turn on when the drawer is moved down. Replace if faulty.

Table 6-2 Error Messages

Error Message	Cause/Action
<p>Unable to Lock Top Jig Check top jig clamp and reed switch sensor</p>	<ol style="list-style-type: none"> 1 Check that the air supply is turned on. 2 Check the top fixture's lock/unlock cylinder and replace if faulty. 3 Check the top fixture's lock reed switch (RS-3). It should turn on when the top fixture is locked. Replace if faulty.
<p>Unable to Unlock Top Jig Check top jig clamp and reed switch sensor</p>	<ol style="list-style-type: none"> 1 Check that the air supply is turned on. 2 Check the top fixture's locking cylinder and replace if faulty. 3 Check the top fixture's unlock reed switch (RS-4) and replace if faulty.
<p>Unable to Clamp Bottom Jig Check reed switch sensor and fixture clamp</p>	<ol style="list-style-type: none"> 1 Check that the air supply is turned on. 2 Check the bottom fixture's clamping cylinders and replace if faulty. 3 Check the bottom fixture clamp's lock reed switches (front right RS-5, front left RS-7, rear right RS-9, rear left RS-11). They should turn on when the bottom fixture is locked. Replace if faulty.
<p>Unable to Unclamp Bottom Jig Check reed switch sensor and fixture clamp</p>	<ol style="list-style-type: none"> 1 Check that the air supply is turned on. 2 Check the bottom fixture's clamping cylinders and replace if faulty. 3 Check the bottom fixture clamp's unlock reed switches (front right RS-6, front left RS-8, rear right RS-10, rear left RS-12). They should turn on when the bottom fixture is unlocked. Replace if faulty.
<p>Scanner Timeout Please check board position and barcode label</p>	<p>For systems with optional barcode reader in use.</p> <ul style="list-style-type: none"> • Check the Scanner's feedback to PLC.
<p>ICT Timeout Check Serial connection to PLC</p>	<ul style="list-style-type: none"> • Check the controller's feedback to PLC.
<p>Unable to Auto Width Conveyor Remove board from conveyor</p>	<p>A board cannot be present when setting the conveyor width via the LCD touch panel. Remove the board before setting the width.</p>
<p>Unable to Move Press to ORIGIN Check ORIGIN sensor</p>	<ul style="list-style-type: none"> • Check the Press origin sensor (PHS-14) and replace if faulty.
<p>Press Servo Brake Error Check servo driver, restart system if necessary</p>	<p>The servo motor's brake did not release within the preset time.</p> <ul style="list-style-type: none"> • Restart the system.
<p>Unable to Move Press Move drawer DOWN</p>	<p>The drawer is not in the lowered position.</p> <ul style="list-style-type: none"> • Check the Right Drawer Down sensor (PHS-21). • Lower the drawer.

Table 6-2 Error Messages

Error Message	Cause/Action
<p>Unable to Move Press Check drawer (left/right) sensor</p>	<p>The drawer is not in the lowered position.</p> <ul style="list-style-type: none"> • Check the drawer’s Left Drawer Down Sensor (PHS-23) and/or Right Drawer Down sensor (PHS-21). • Lower the drawer.
<p>Press Safety Hook (Front) Not Released Release safety hook or check safety hook sensor</p>	<ul style="list-style-type: none"> • Disengage the front safety hook. • Check the front hook sensor (PHS-17). See Sensor Troubleshooting.
<p>Press Safety Hook (Rear) Not Released Release safety hook or check safety hook sensor</p>	<ul style="list-style-type: none"> • Disengage the rear safety hook. • Check the rear hook sensor (PHS-16). See Sensor Troubleshooting.
<p>Board Manually Removed During AUTO Mode Remove all boards and restart testplan</p>	<p>A board was removed when the system is running in Auto mode.</p> <ol style="list-style-type: none"> 1 Restart the testplan.
<p>Incomplete Board Status at Zone 2 Remove board manually and restart testplan</p>	<p>A board is at the exit position of Zone 2 but no status is received from the controller.</p> <ul style="list-style-type: none"> • Remove the board and restart the testplan.

Sensor Calibration and Troubleshooting

- [Calibrating PHS-13 \(Presser Lower Limit Sensor\)](#)
- [Troubleshooting PHS-1 to PHS-7](#)
- [Troubleshooting PHS-12 to PHS-14, PHS-24 to PHS-26](#)
- [Troubleshooting PHS-16 and PHS-17](#)

See also: [Sensor Layout](#)

Calibrating PHS-13 (Presser Lower Limit Sensor)

The lowest position of the Press is defined by the Presser Lower Limit Sensor (PHS13, see [Figure 6-5](#) for the location). It must allow the Press to move down sufficiently for the probes to contact the board during testing, but if it is set too low the Press may hit the components on the board.

Figure 6-1 Presser Lower Limit Sensor

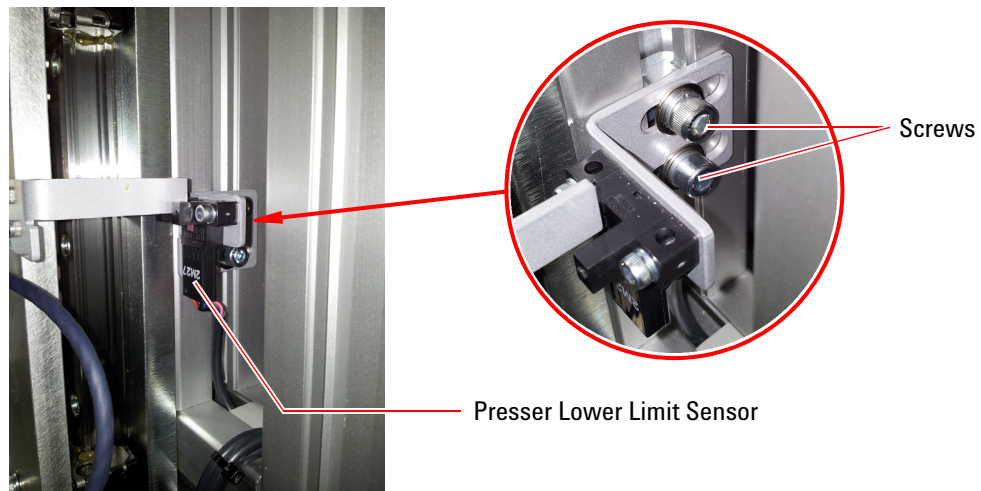

To calibrate the presser lower limit sensor, load a 75 mm bottom fixture and position a reference board against the Zone 2 stopper.

- 1 Open the Zone 2 door.
- 2 Select **Maintenance** mode on the [LCD touch panel](#).
Press **Presser** to go to page 6.

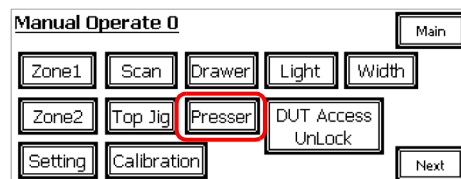

- 3 Press **Origin** to move the Press to its start position.

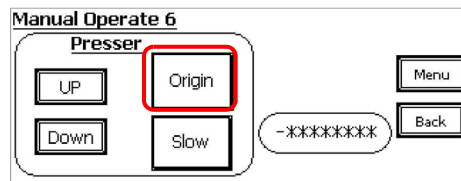

- 4 *If the lower limit sensor is too high:*
Loosen the two screws securing the sensor bracket (Figure 6-1) and move the sensor down to allow the Press to move down.
- 5 Press and hold **Down** to lower the Press until all the probes are contacting the board.

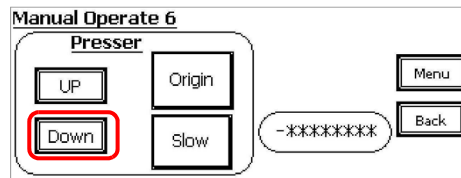

NOTE Press **Slow** to slow the movement of the Press if necessary.

- 6 *If the lower limit sensor is too low:*
Loosen the two screws securing the sensor bracket (Figure 6-1).
- 7 Adjust the position of the lower limit sensor:
 - a Slide the sensor slowly upwards until it is activated by the sensing plate (the red sensor light will turn on).
 - b Slide the sensor down slightly, just enough to turn the sensor light off. Tighten the two screws on the sensor bracket.

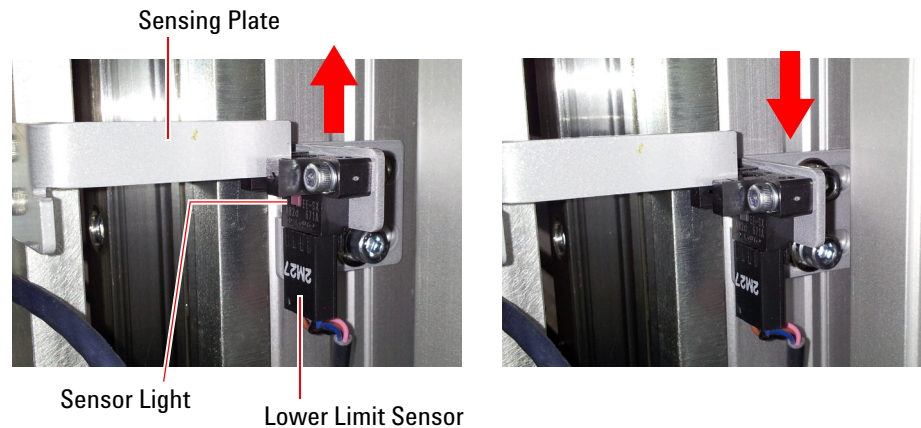

- 8** Test the sensor positioning:
 - a** On the LCD Touch Panel, press and hold **UP** to move the Press up.
 - b** Press and hold **Down** to move the Press down until the probes are contacting the board.
Check that the lower limit sensor is still off at this point.

Troubleshooting PHS-1 to PHS-7

These are the Zone 1 and Zone 2 sensors triggered by the board.

PHS-1	Zone 1 Inlet Sensor
PHS-2	Zone 1 Stopper Sensor
PHS-3	Zone 1 Exit Sensor
PHS-4	Zone 2 Inlet Sensor
PHS-5	Zone 2 Stopper Slow Sensor
PHS-6	Zone 2 Stopper Sensor
PHS-7	Zone 2 Exit Sensor

See [Figure 6-5](#) for the location of the sensors; also see [Figure 6-7](#) and [Figure 6-8](#).

Check the sensor response

- Use a board to trigger the sensor and see whether it responds (see [Figure 6-2](#)).

Figure 6-2 Board Sensor

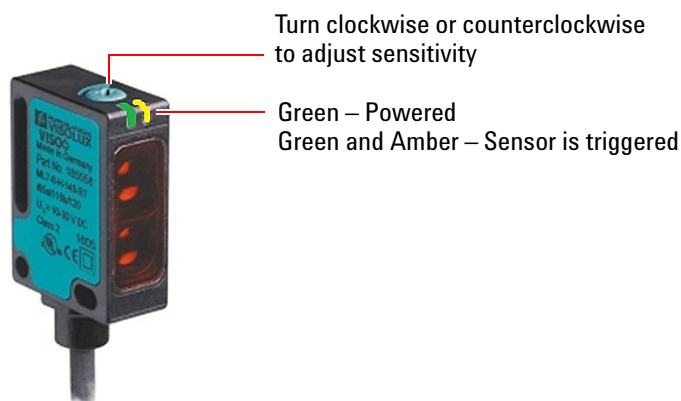

If the sensor doesn't respond

Check the sensor response after each step and continue only if the sensor fails to respond.

- 1 Adjust the sensor sensitivity by turning the control clockwise or anti-clockwise.
- 2 Check the connectors and ensure there is power to the sensor.
- 3 Replace the sensor.

If the sensor responds

- 1 Trigger the sensor again and check if the PLC responds (check the PLC I/O indicator).
If the PLC responds, it was likely an intermittent failure and no further action is needed.
- 2 If the PLC does not respond, perform a continuity check on the PLC's connector signal terminals.
- 3 If the continuity check fails, check the cables and connectors.

Troubleshooting PHS-12 to PHS-14, PHS-24 to PHS-26

See [Figure 6-5](#) on page 6-17 for the location of the sensors.

- PHS-12 Presser Upper Limit Sensor
- PHS-14 Presser Home Sensor
- PHS-13 Presser Lower Limit Sensor
- PHS-25 Conveyor Right Limit Sensor
- PHS-24 Conveyor Origin Sensor
- PHS-26 Conveyor Left Limit Sensor

See [Figure 6-5](#) for the location of the sensors; also see [Figure 6-7](#) and [Figure 6-8](#).

Check the sensor response

- Manually trigger the sensor and see whether it responds.

Figure 6-3 Board Sensor

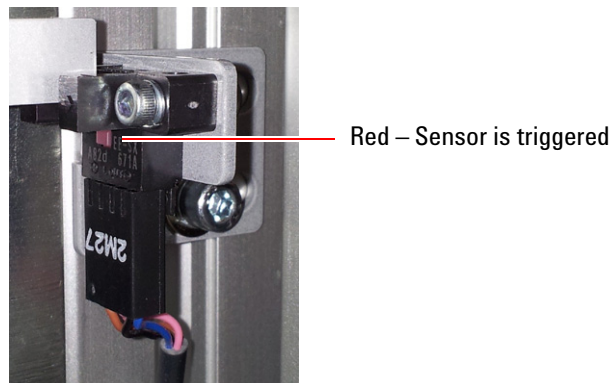

If the sensor doesn't respond

Check the sensor response after each step and continue only if the sensor fails to respond.

- 1 Check the connectors and ensure there is power to the sensor.
- 2 Replace the sensor.

If the sensor responds

- 1 Trigger the sensor again and check if the PLC responds (through the PLC I/O indicator).

If the PLC responds, it was likely an intermittent failure and no further action is needed.

- 2 If the PLC does not respond, perform a continuity check on the PLC's connector signal terminals.
- 3 If the continuity check fails, check the cables and connectors.
- 4 Trigger the sensor again.
- 5 If the PLC still does not respond, replace the gap sensor connector (with cable).



Gap sensor connector
for PHS-14

Troubleshooting PHS-16 and PHS-17

These sensors detect if the rear and front safety hooks on the Press are disengaged.

Figure 6-4 Rear Safety Hook

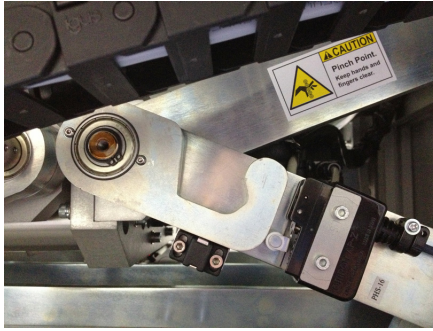

Check the sensor response

- Disengage the hook to trigger the sensor and see whether it responds.

If the sensor doesn't respond

Check the sensor response after each step and continue only if the sensor fails to respond.

- 1 Check the connectors and ensure there is power to the sensor.
- 2 Replace the sensor.

If the sensor responds

- 1 Trigger the sensor again and check if the PLC responds (through the PLC I/O indicator).

If the PLC responds, it was likely an intermittent failure and no further action is needed.

- 2 If the PLC does not respond, perform a continuity check on the PLC's connector signal terminals.
- 3 If the continuity check fails, check the cables and connectors.

Sensor Layout

Table 6-3 lists the sensors in the system, together with their IDs and signals to the PLC. The following figures show the locations of the sensors in a left-to-right system. The sensor ID will be marked on labels in the system.

Table 6-3 Sensors

Sensor	ID	Signal to PLC
Zone 1 Inlet Sensor	PHS-1	000
Zone 1 Stopper Sensor	PHS-2	001
Zone 1 Exit Sensor	PHS-3	002
Scanner Front	SV11,1104	RS17, 208
Scanner Rear	SV12,1105	RS18, 209
Zone 2 Guide Bar Detect Sensor	PHS-19	306
Conveyor Right Limit Sensor (Dark-on)	PHS-25	400
Conveyor Origin Sensor (Dark-on)	PHS-24	315
Conveyor Left Limit Sensor (Dark-on)	PHS-26	401
Zone 1 Stopper Up	SV1,1010	RS1, 108
Zone 1 Stopper Down	SV2,1011	RS2, 109
Zone 2 Inlet Sensor	PHS-4	003
Zone 2 Stopper Slow Sensor	PHS-5	004
Zone 2 Stopper Sensor	PHS-6	005
Board Align Sensor	PHS-27	402
Engine Fully In Detect Sensor	PHS-9	008
Zone 2 Stopper Down	SV4,1013	RS20, 211
Zone 2 Stopper Up	SV3,1012	RS19, 210
Zone 2 Exit Sensor	PHS-7	006
Zone 2 Clear Sensor	PHS-8	007
Presser Upper Limit Sensor	PHS-12	011
Presser Home Sensor	PHS-14	013
Presser Clearance Limit Sensor	PHS-15	014
Presser Lower Limit Sensor	PHS-13	012

Table 6-3 Sensors

Sensor	ID	Signal to PLC
Top Press Assembly		
Rear Safety Hook Detect Sensor	PHS-16	015
Top Jig Lock	SV5,1014	RS3,110
Top Jig Unlock	SV6,1015	RS4,111
Top Jig Fully In Detect Sensor	PHS-19	101
Front Safety Hook Detect Sensor	PHS-17	100

Table 6-4 Motors and Controls

Motor/Control	ID	
Presser Servo Motor	M1	
Zone 1 Motor	M2	
Zone 2 DC Motor	M3, M4	
Lighting	LT1	
Tester Self-test (not used)	PB2	102, 1001
Bottom Jig Lock	PB3	103, 1002
Drawer Control 1	PB4	104, 1003
Drawer Control 2	PB5	105, 1004
Top Jig Lock	PB6	106, 1005
Maintenance Key Switch	KS1	107
Emergency Stop	EM2	015

Figure 6-5 Sensor Locations in Left-to-Right System

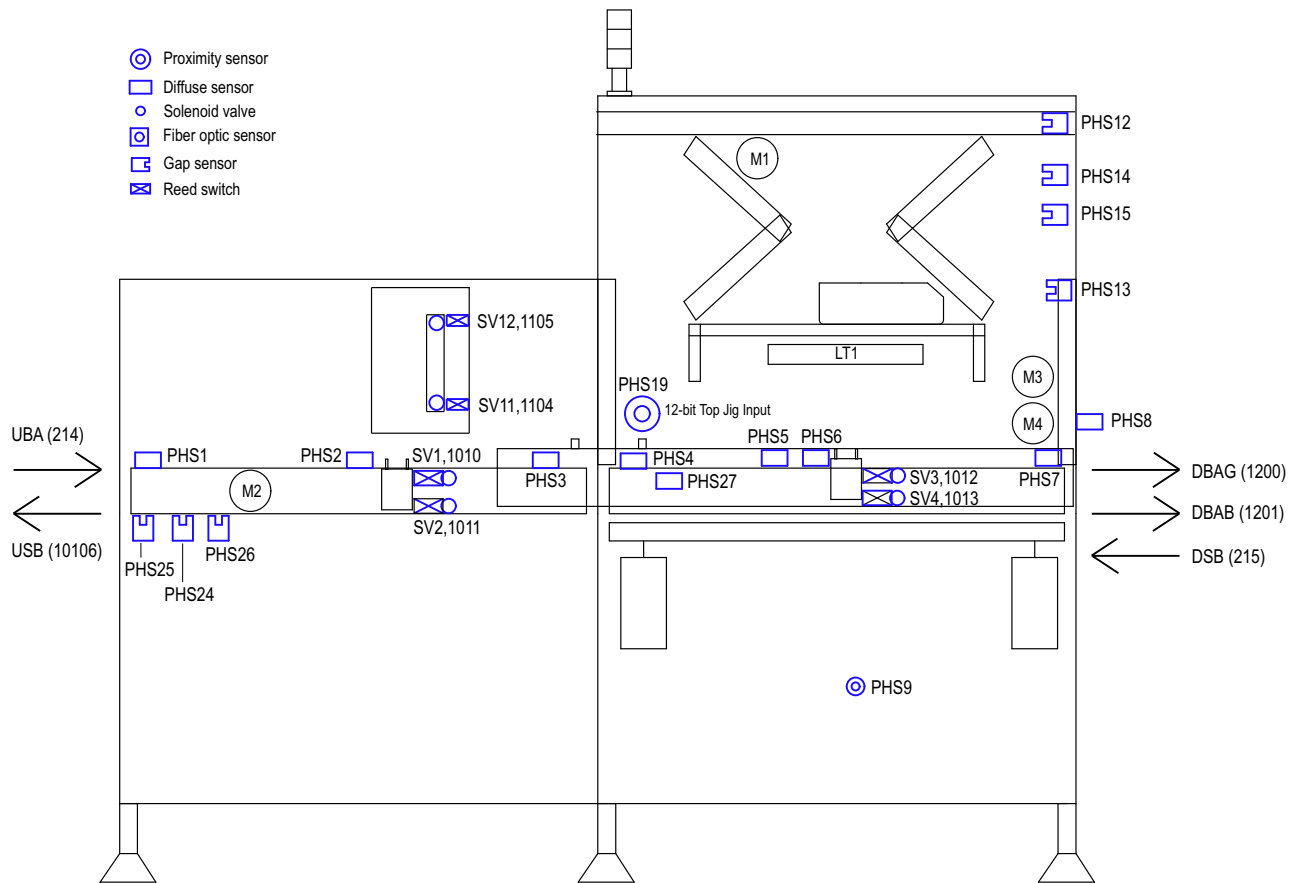

Figure 6-6 Press and Conveyor Sensors

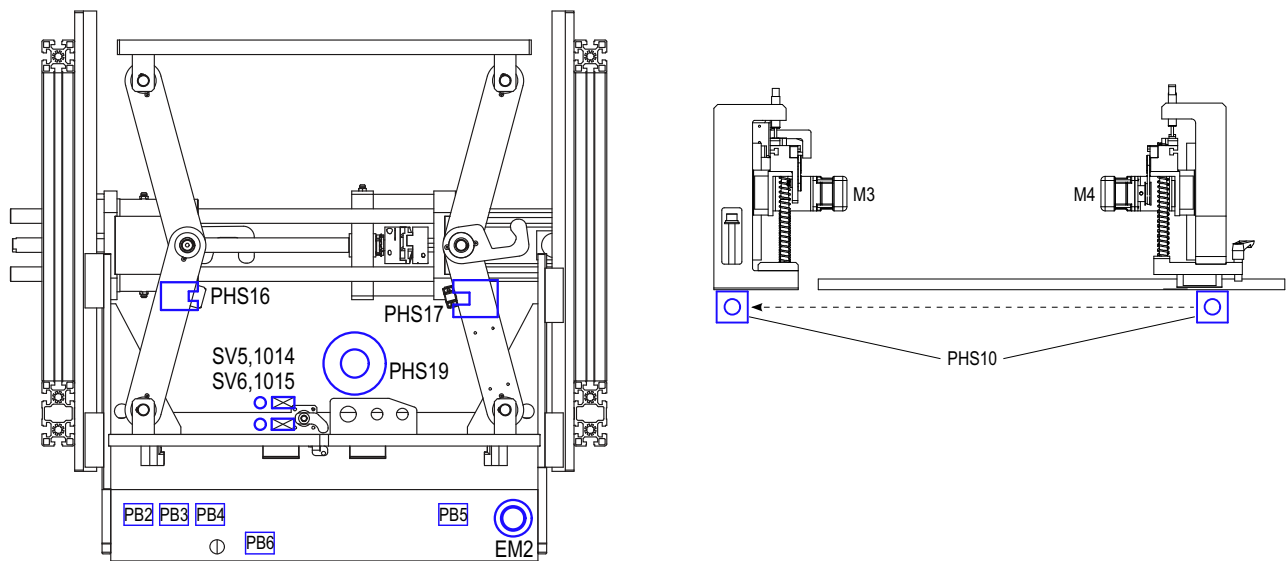
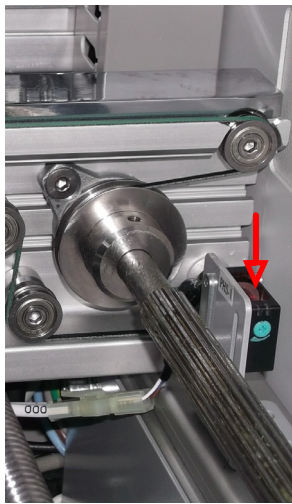
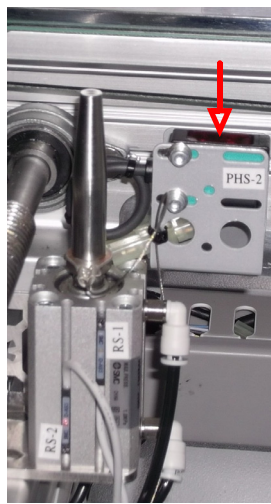

Figure 6-7 Zone 1 and Press Sensors



Zone 1 Inlet Sensor
PHS-1



Zone 1 Stopper Sensor
PHS-2

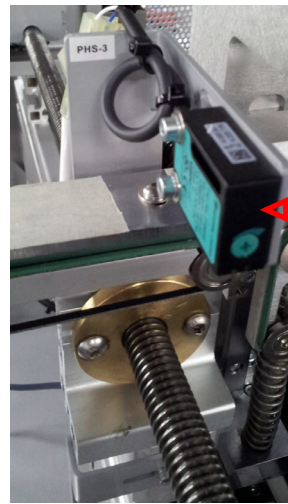

Zone 1 Exit Sensor
PHS-3



Presser
Upper Limit Sensor
PHS-12

Presser
Home Sensor
PHS-14

Presser
Lower Limit Sensor
PHS-13



Front Safety Hook Detect Sensor
PHS-17

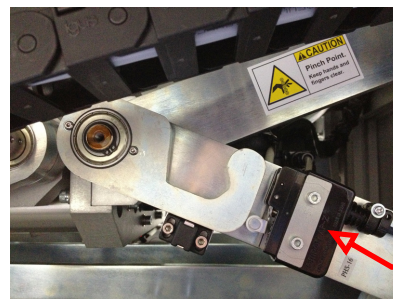

Rear Safety Hook Detect Sensor
PHS-16

Figure 6-8 Zone 2 Sensors

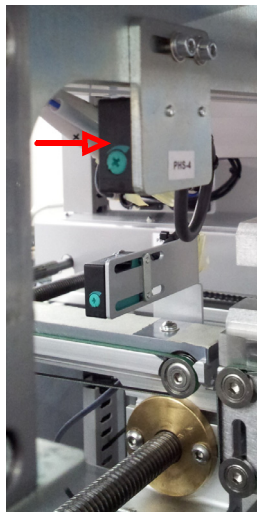

Zone 2 Inlet Sensor
PHS-4

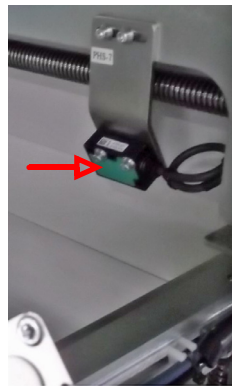

Zone 2 Exit Sensor
PHS-7

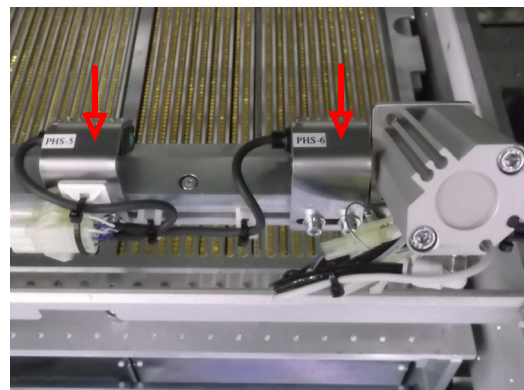

Zone 2 Stopper Slow Sensor PHS-5
Zone 2 Stopper Sensor PHS-6

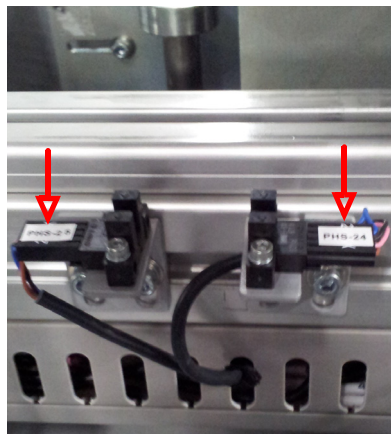

Conveyor
Right Limit Sensor
PHS-25

Conveyor
Origin Sensor
PHS-24

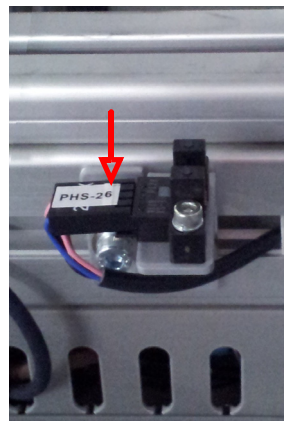

Conveyor
Left Limit Sensor
PHS-26



7 Replacement Procedures

- Accessing the Testhead [7-2](#)
- Replacing Cards in the Testhead [7-5](#)
- Replacing i-System Card [7-8](#)
- Replacing Runner Blocks [7-10](#)
- Replacing Module Power Unit (MPU) [7-21](#)
- Installing DUT Power Supply [7-23](#)
- Replacing Servo Motor [7-27](#)
- Replacing Press Components [7-31](#)
- Replacing Zone 1 Conveyor Belt [7-35](#)
- Replacing Zone 2 Conveyor Belt/Spring [7-39](#)
- Replacing Conveyor Motors [7-48](#)

CAUTION

Turn off the PDU on/off switch before beginning any replacement procedure, unless otherwise stated.

Accessing the Testhead

- 1 Unload the bottom fixture:
 - a Select **Maintenance** mode on the [LCD touch panel](#). Press **Drawer** to go to page 4.
 - b Press **Unlock** to unlock the bottom fixture, then press **UP** to move the drawer up.

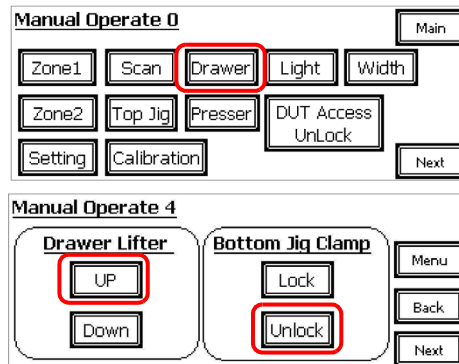

- c Open the Zone 2 door and pull out the drawer to remove the bottom fixture.
 - d Push the drawer back into place.
- 2 Turn off the PDU on/off switch.
- 3 Unlock and remove the testhead pod cover.

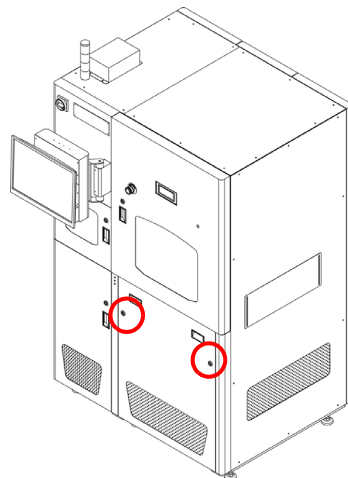

See [Figure 7-1](#) for the following steps.

- 4 Loosen the star knobs and pull out the testhead using the handle in the guide bar.
- 5 Undo the latches on both sides of the guide bar. Set the bar aside (it can be stowed in the space provided at the right side of the testhead as shown in [Figure 7-2](#)).

- 6 Use the hand crank to rotate the testhead. The direction depends on the part being replaced.

Figure 7-1 Accessing the Testhead

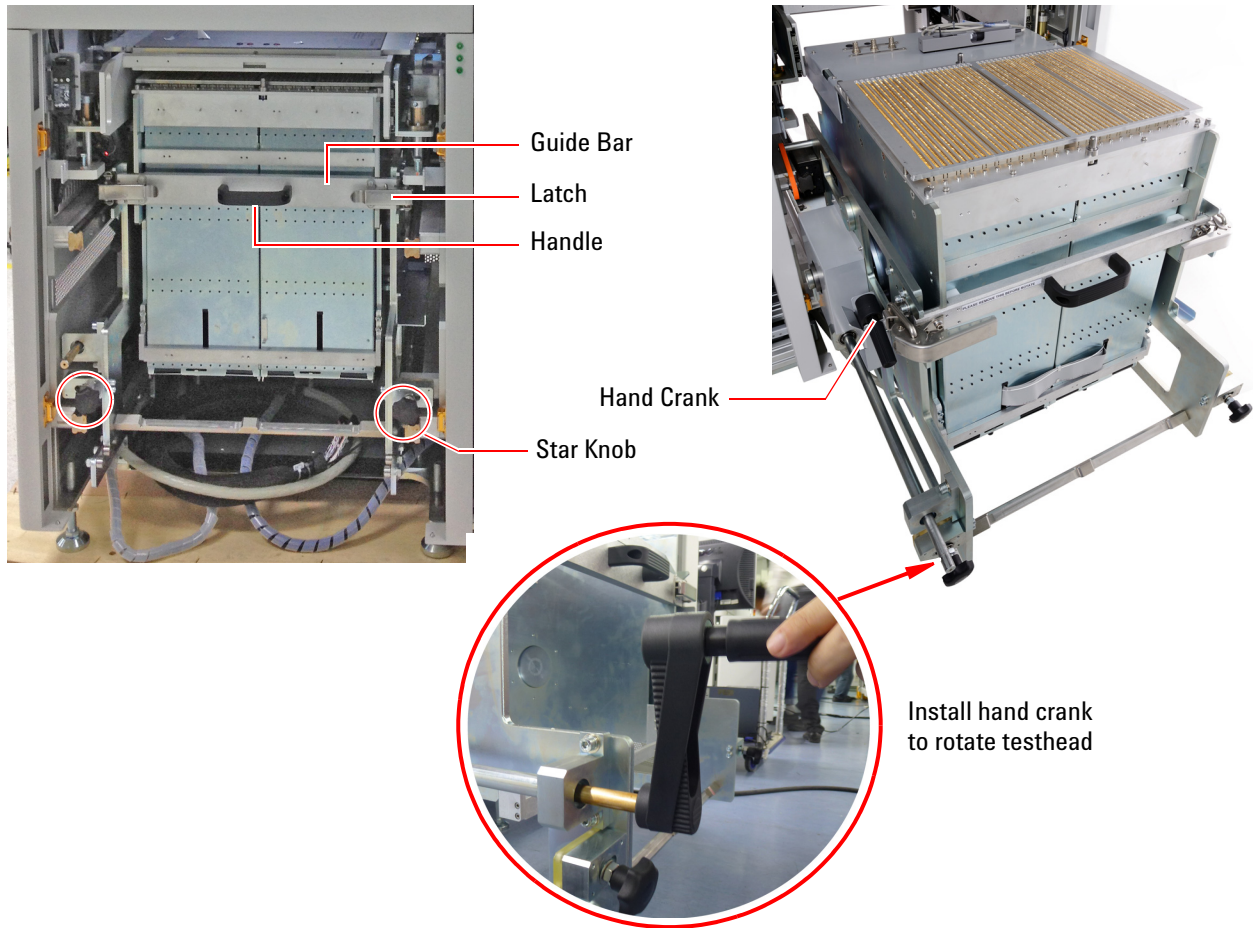
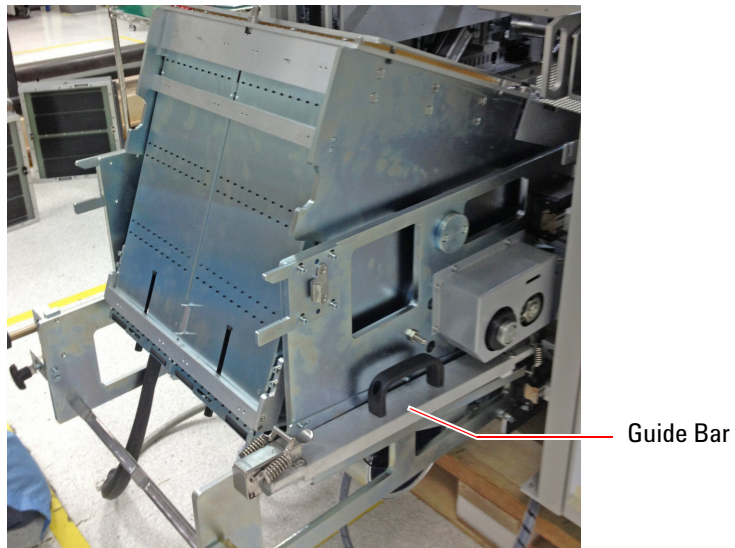

Figure 7-2 Stowing the guide bar



Replacing Cards in the Testhead

Follow this procedure to replace the ASRU Card (slot 1), Module Control Card (slot 6), or any of the pin cards in the testhead.

Removal

- 1 Follow the instructions in [Accessing the Testhead](#).
- 2 Turn the hand crank counterclockwise to rotate the testhead 120 degrees until the blower door is facing you ([Figure 7-3](#)).
- 3 Release the latches and open the blower door.

Figure 7-3 Accessing the Cards

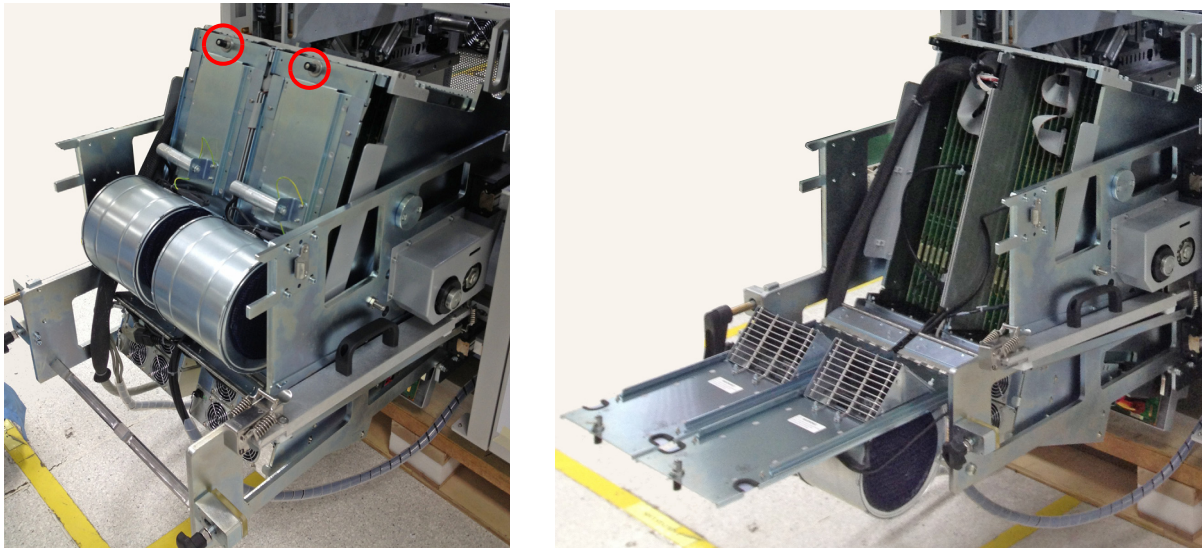

- 4 It may be necessary to remove cables from the ASRU Card (slot 1) and the Module Control Card (slot 6) to allow the other cards to be removed. Note how these cables are installed before removing them.
- 5 Loosen the retaining screw on each side of the card to be replaced.
- 6 Carefully remove the card, holding it by the handle and edges, and place it in an ESD-safe bag.

Installation

CAUTION

To prevent electrostatic discharge (ESD) from damaging sensitive components on module/slot cards, wear a tested, grounded, anti-static wrist strap while performing this procedure. Connectors for the wrist strap are provided at the front of the system

- 1 Remove the new card from the ESD-safe bag. Hold it only by the board handle and board edges to reduce the probability of ESD damage and contamination.
- 2 If replacing a Module Control Card, record the 12-digit hardware address before installing it. The hardware address is printed on a label on the rear corner of the card.
- 3 Install the card with its component side facing the same way as the other cards in the module. Push firmly to seat the card in the connector, but **do not** force the card since it can damage the connector.
- 4 Reconnect cables as needed.

CAUTION

It is very easy to bend connector pins when reconnecting the DUT power supply cables. Be sure to align the connectors carefully.

CAUTION

Failure to maximize air flow by proper cable routing will cause "hot spot" overheating. Overheating will shorten the useful life of digital components on module cards.

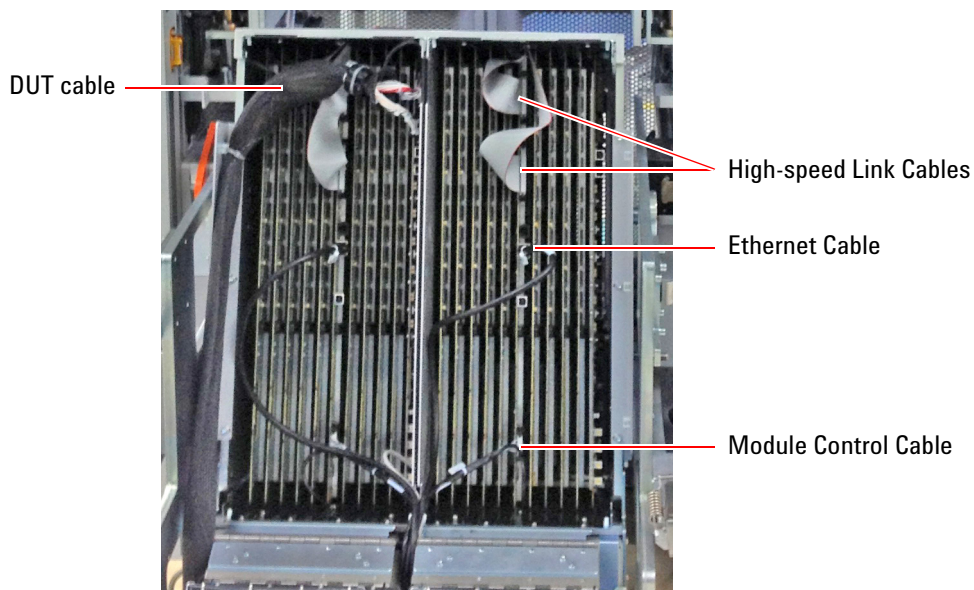

- 5 Tighten the retaining screw on each side of the card. If the screws do not thread properly, reseal the card in the connector.

CAUTION

If the retaining screws are not tightened, the card will be pushed out of its connector when a test fixture is pulled down, possibly damaging the system.

- 6 Tidy the cables and hold them in place with cable ties if necessary. Be careful not to crimp any cables in the blower door and not to route cables in front on the fans.
- 7 If replacing a Module Control Card, update the hardware address in the system software before booting the testhead, otherwise there will be boot errors.
- 8 Close and secure the blower door.
- 9 Rotate the testhead back into position and stow the hand crank. Replace the guide bar and fasten the latches.
- 10 Push the testhead back into the system and tighten the star knobs.
- 11 Close all doors/covers.

Replacing i-System Card

The i-System Card is installed in the controller pod.

Removal

- 1 Open the rear door to access the back of the i-System Card Assembly. Disconnect the cables.
- 2 Open the controller pod door.
- 3 Remove the four dress screws securing the i-System Card Assembly and remove the assembly.

Installation

- 1 Slide the new i-System Card Assembly along the support rails into the system.
- 2 Secure it with four dress screws.

Figure 7-4 i-System Card Assembly in Controller Pod

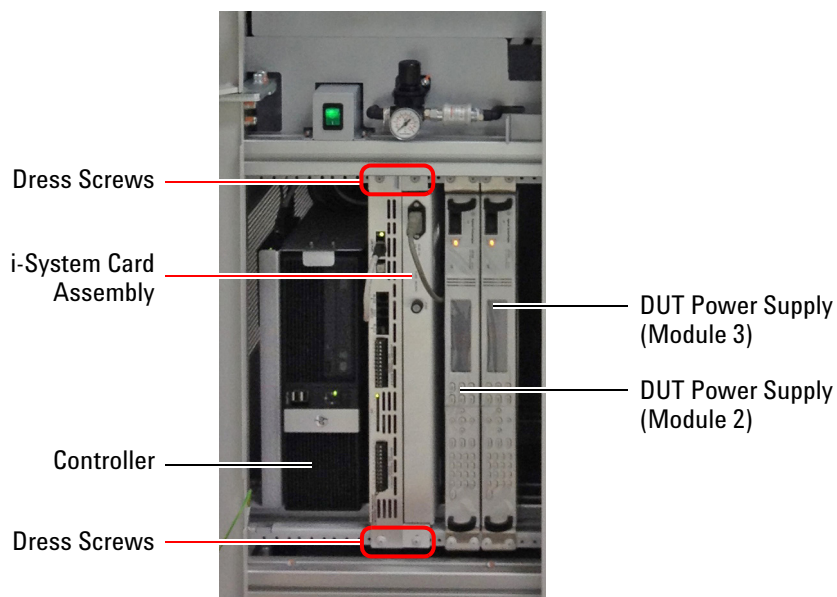

- 3 Open the rear door to reconnect the cables to the i-System card.

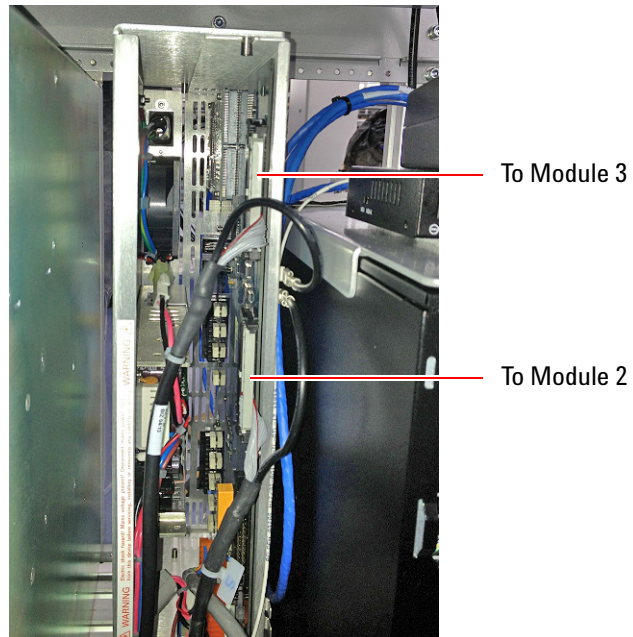

Replacing Runner Blocks

- Testhead Runner Blocks
- Press Lower Runner Block
- Press Upper Runner Block
- Zone 2 Conveyor Runner Block (Up/Down)
- Zone 2 Conveyor Runner Block (Width Adjustment)

NOTE

Replace runner blocks one at a time.
Remove the fixture before replacing parts in the Press assembly.

Testhead Runner Blocks

There are two guide rails on each side of the testhead, with two runner blocks on each guide rail. The runner blocks are accessed from the rear of the system.

Figure 7-5 Testhead Runner Blocks

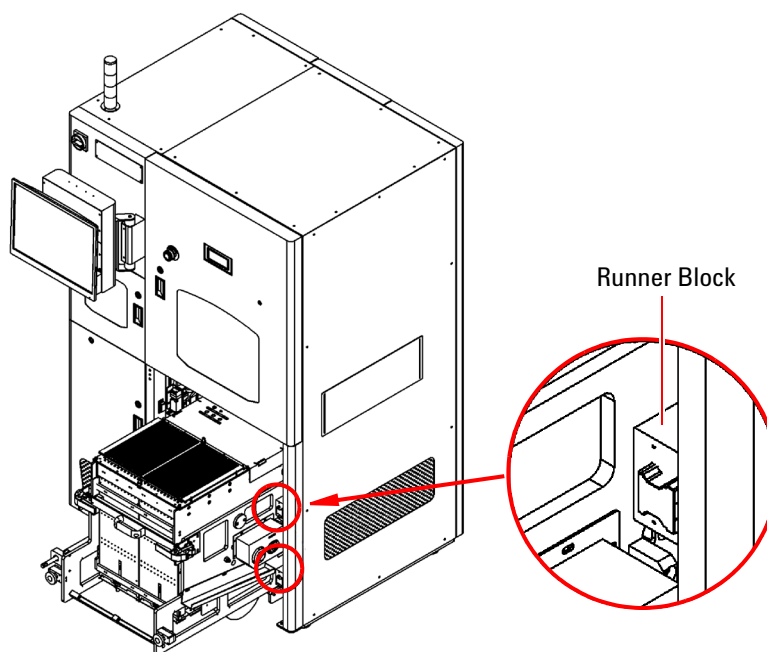

Removal

- 1 Follow the instructions in [Accessing the Testhead](#).
- 2 Turn the hand crank clockwise to rotate the testhead about 90 degrees.
- 3 Open the rear doors to access the runner blocks from the rear of the system.

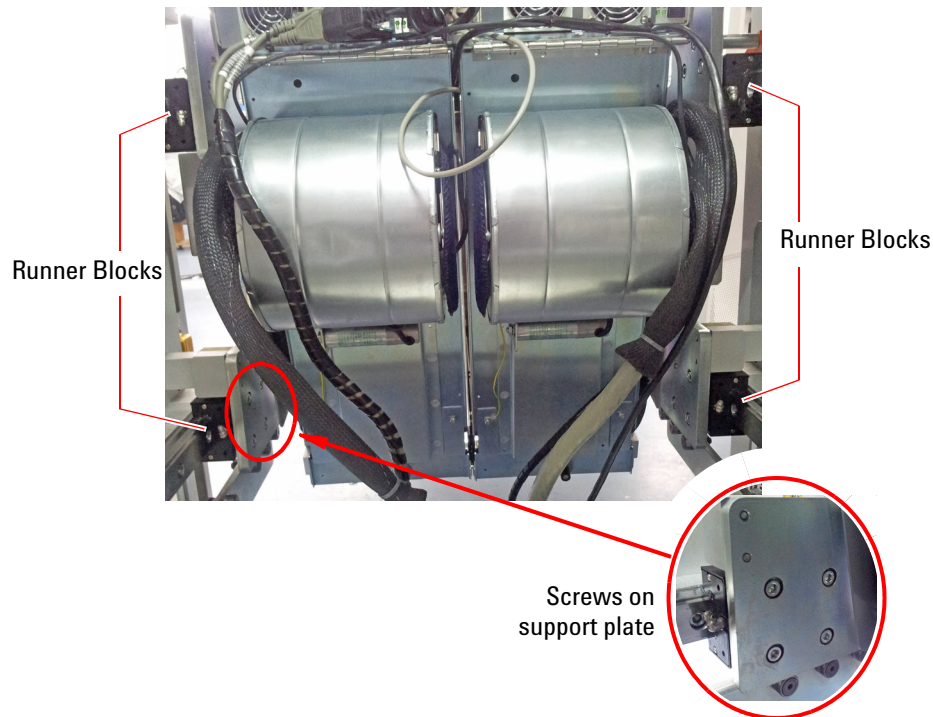

- 4 Remove the four screws securing the runner block to be replaced. Slide the runner block out along the guide rail.

Installation

- 5 Slide the new runner block along the guide rail into the system. Align the mounting holes and secure with the four screws.
- 6 Rotate the testhead back into position and stow the hand crank. Replace the guide bar and fasten the latches.
- 7 Push the testhead back into the system and tighten the star knobs.
- 8 Close all doors/covers.

Press Lower Runner Block

The Press has four guide rails with two runner blocks on each rail. [Figure 7-6](#) shows the runner blocks visible from the front of the system.

Figure 7-6 Front Runner Blocks for Press

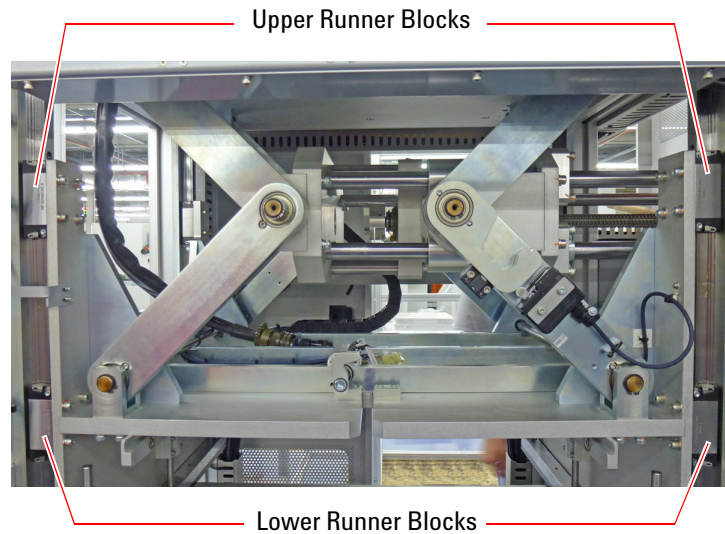

Removal

Follow this procedure to replace a lower runner block. Power must be connected to begin this procedure.

- 1 Select **Maintenance** mode on the [LCD touch panel](#).
 - a Press **Presser** to go to page 6.
 - b Press **Origin** to move the Press to its origin position.
 - c Then press and hold **UP** to move the Press all the way up.

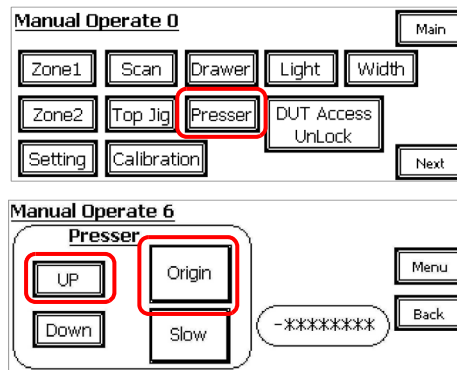

- 2 Open the Zone 2 door and rear doors to access the Press. Lock the front and rear hooks on the Press.

Front Hook Locked

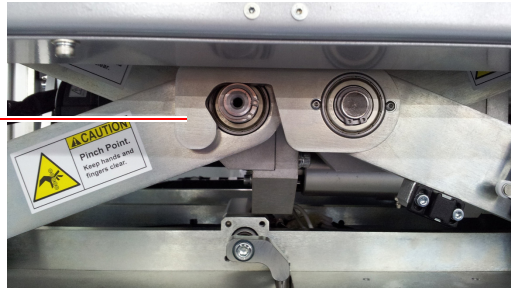

Rear Hook Locked

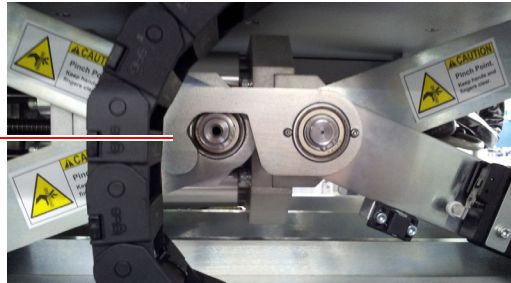

- 3 Turn off the PDU on/off switch.
- 4 Remove the lower runner block to be replaced:

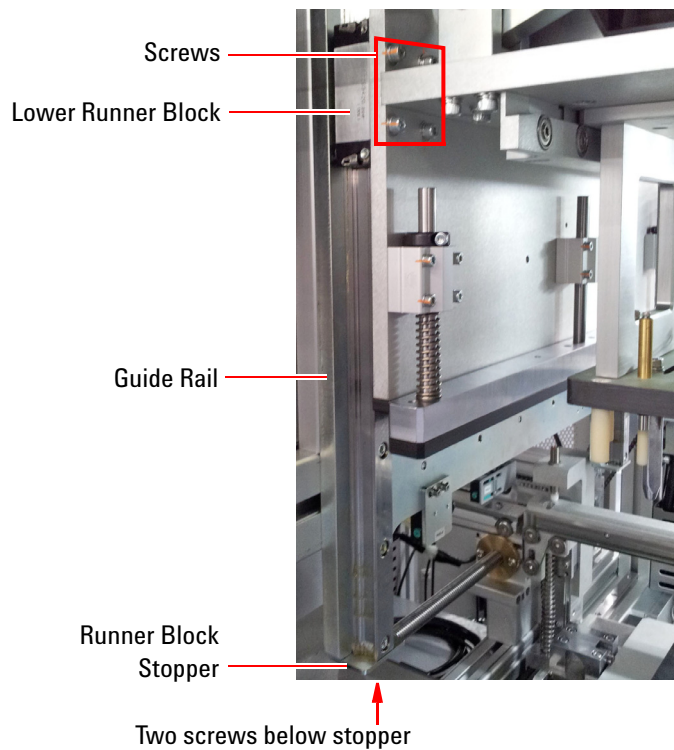

- a Remove two screws below the runner block stopper and remove the stopper.
- b Remove four screws securing the runner block.
- c Slide the runner block down the guide rail to remove it.

Installation

- 1** Slide the new runner block up the guide rail. Align the screw mounting holes and secure with the four screws.
- 2** Install the runner block stopper and secure with the two screws.
- 3** Unlock the front and rear hooks.
- 4** Close all doors.

Press Upper Runner Block

Follow this procedure to replace an upper runner block (Figure 7-6) on the Press.

Removal

Follow this procedure to replace a lower runner block. Power must be connected to begin this procedure.

- 1 Select **Maintenance** mode on the [LCD touch panel](#).
 - a Press **Presser** to go to page 6.
 - b Press **Origin** to move the Press to its origin position.
 - c Then press and hold **Down** to move the Press down until the upper runner blocks can be accessed.

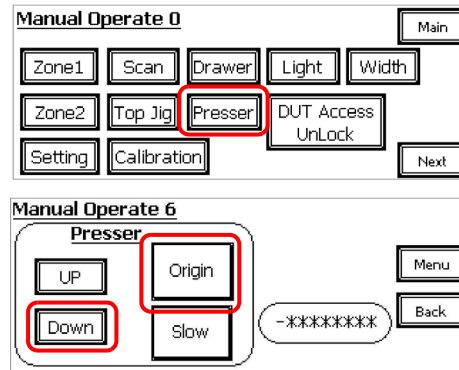

- 2 Turn off the PDU on/off switch.
- 3 Loosen the screws on the two set collars and push the set collars to the linear bearings.

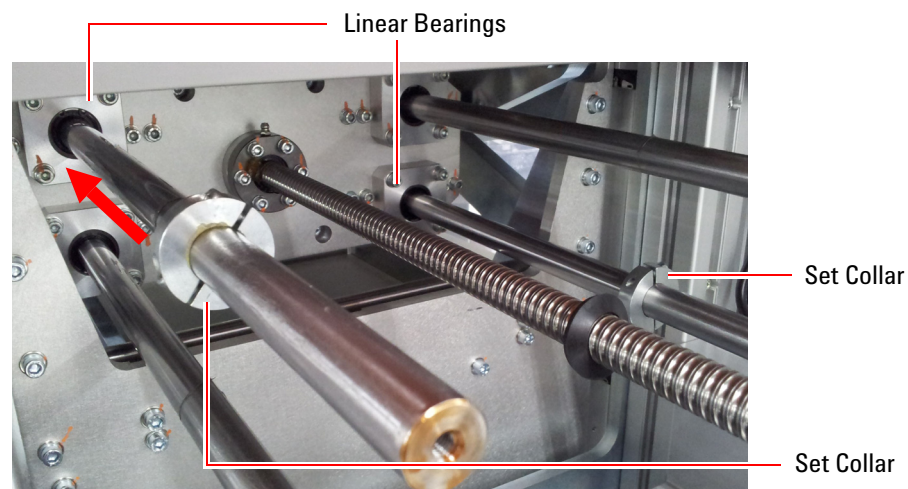

- 4 Remove the runner block that is below the runner block to be replaced:

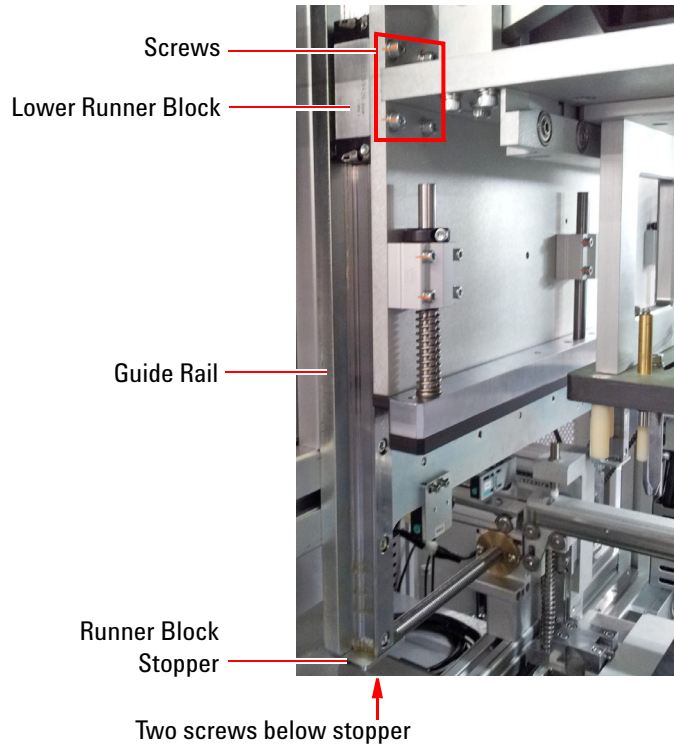

- a Remove two screws below the runner block stopper and remove the stopper.
- b Remove four screws securing the runner block.
- c Slide the runner block down the guide rail to remove it.

- 5 Remove four screws securing the upper runner block. Slide it down the guide rail to remove it.

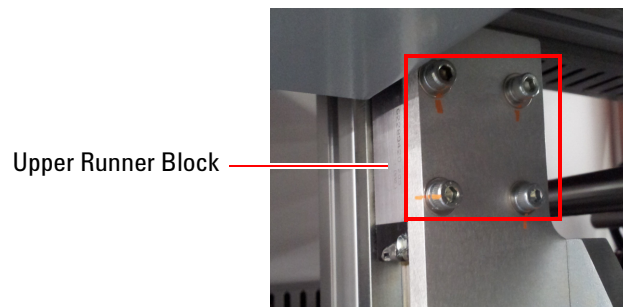

Installation

- 1 Slide the new upper runner block up the guide rail and align the screw mounting holes. Secure with the four screws.
- 2 Install the lower runner block in the same way.
- 3 Install the runner block stopper and secure with the two screws.
- 4 Move the two set collars back into position, 30 mm to 50 mm from the end of the shaft. Tighten the screws on the set collars.
- 5 Close all doors/covers.

Zone 2 Conveyor Runner Block (Up/Down)

Follow this procedure to replace the up/down runner blocks for the Zone 2 conveyor assembly.

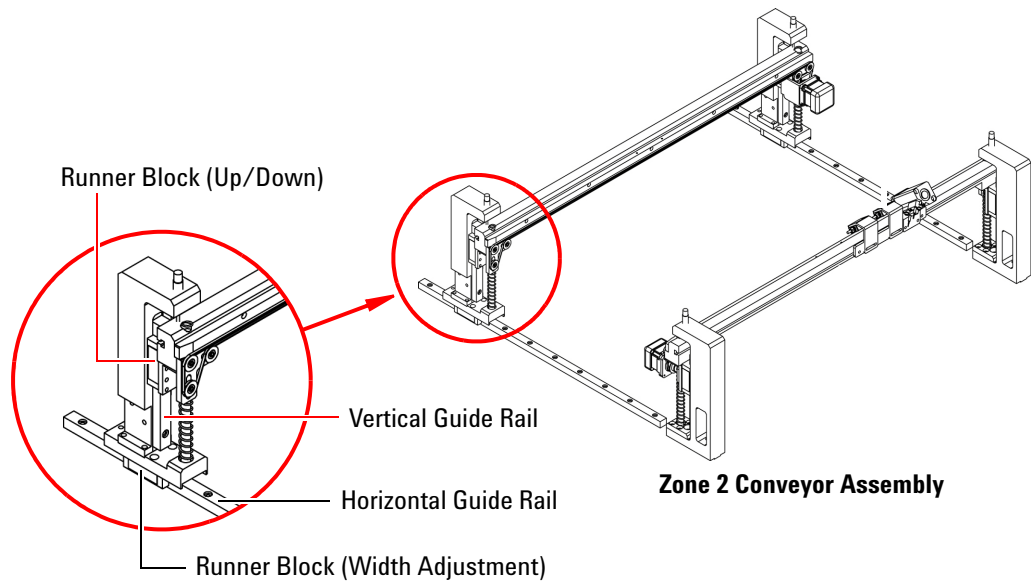

Removal

- 1 Follow the [Removal](#) instructions in [Zone 2 Conveyor Motor \(Movable Side\)](#) to remove the conveyor motor.
- 2 Remove the right side cover.
- 3 To remove the runner block:
 - a Remove two screws to release the runner block from the conveyor.
 - b Remove three screws securing the guide rail to the system.

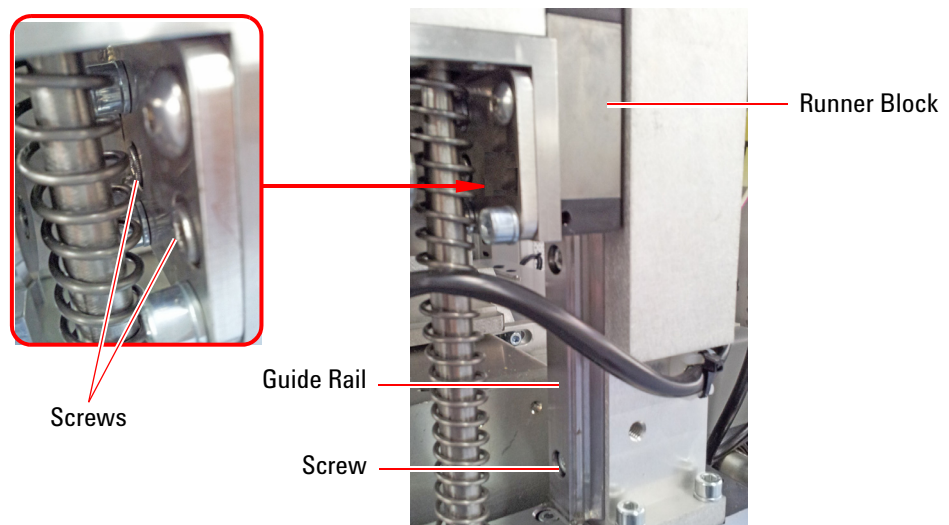

- c The guide rail with runner block can now be removed from the system. Slide the runner block off the guide rail.

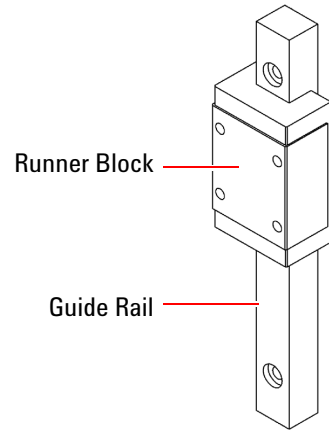

Installation

- 1 Slide the new runner block onto the guide rail.
- 2 Reinstall the guide rail in the system.
- 3 Secure the runner block to the conveyor with two screws.
- 4 Follow the [Installation](#) instructions to install the Zone 2 conveyor motor.
- 5 Close all covers/doors.

Zone 2 Conveyor Runner Block (Width Adjustment)

Follow this procedure to replace the runner blocks for the Zone 2 conveyor's two horizontal guide rails.

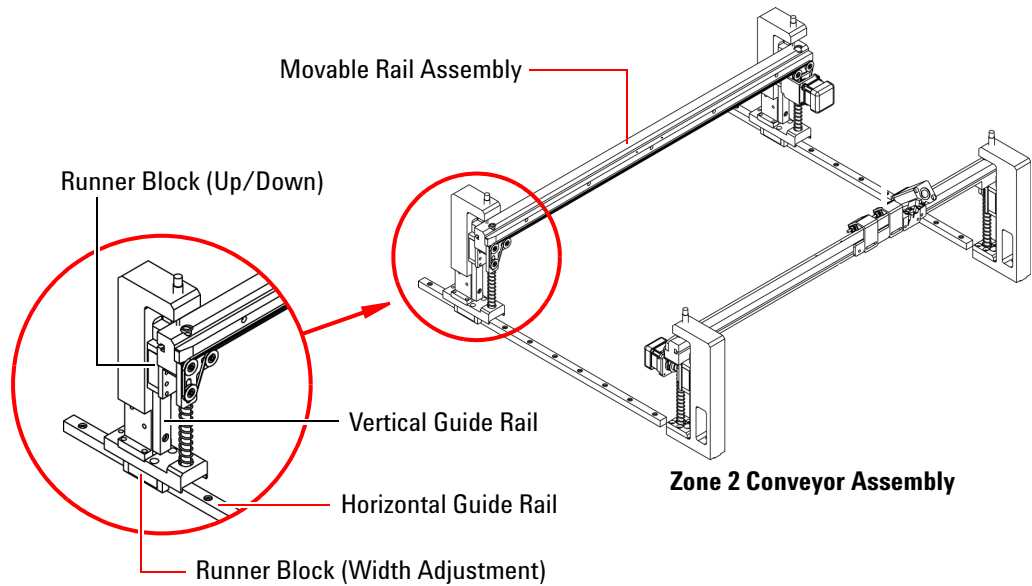

Removal

- 1 Remove the right side cover.
- 2 Remove the movable rail assembly:
 - a Remove six screws securing one side of the rail assembly.

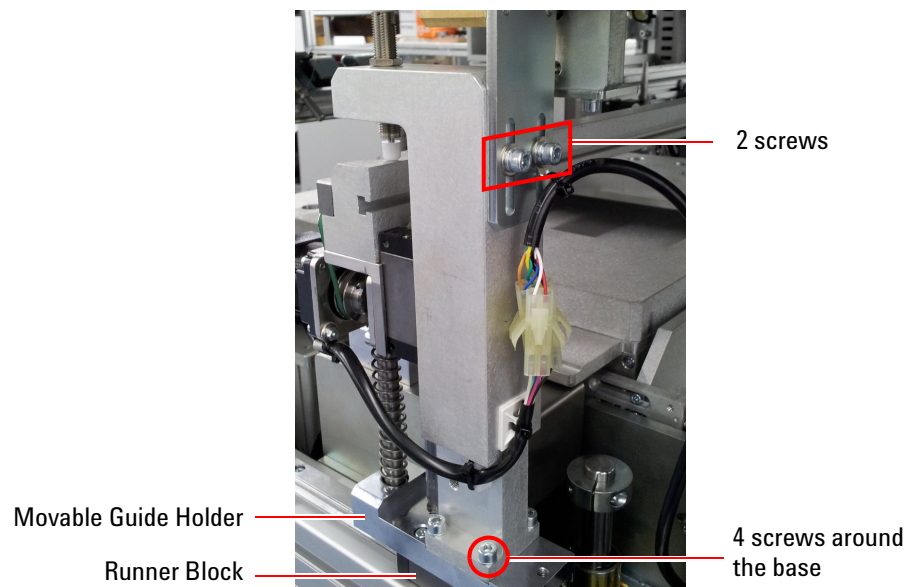

- b Do the same on the other side and remove the rail assembly. The guide rail can now be accessed.

- 3** To remove the runner block:
 - a** Remove four screws to remove the movable guide holder.
 - b** Remove 10 screws securing the guide rail to the system.

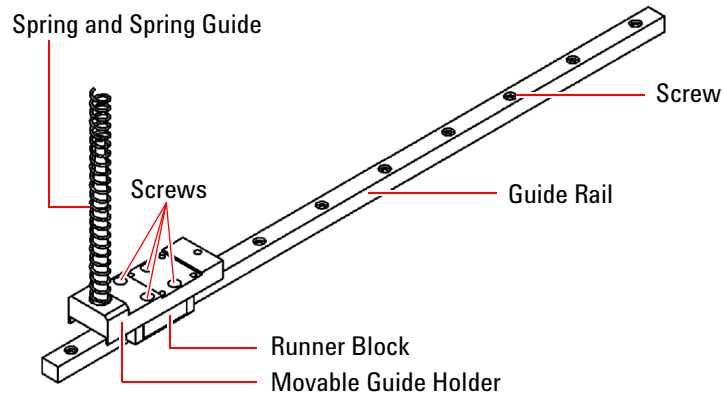

- c** Slide the runner block off the guide rail.

Installation

- 1** Slide the new runner block onto the guide rail.
- 2** Reinstall the guide rail in the system. Secure with 10 screws.
- 3** Secure the movable guide holder (four screws) to the guide rail.
- 4** Reinstall the movable rail assembly. On each side, tighten the four screws at the base and make sure the rail assembly is properly aligned before tightening the two screws at the top.
- 5** Close all covers/doors.

Replacing Module Power Unit (MPU)

There is a Module Power Unit (MPU) for each module in the testhead.

Removal

- 1 Follow the instructions in [Accessing the Testhead](#).
- 2 Turn the hand crank counterclockwise to rotate the testhead 90 degrees until the MPUs are facing up.

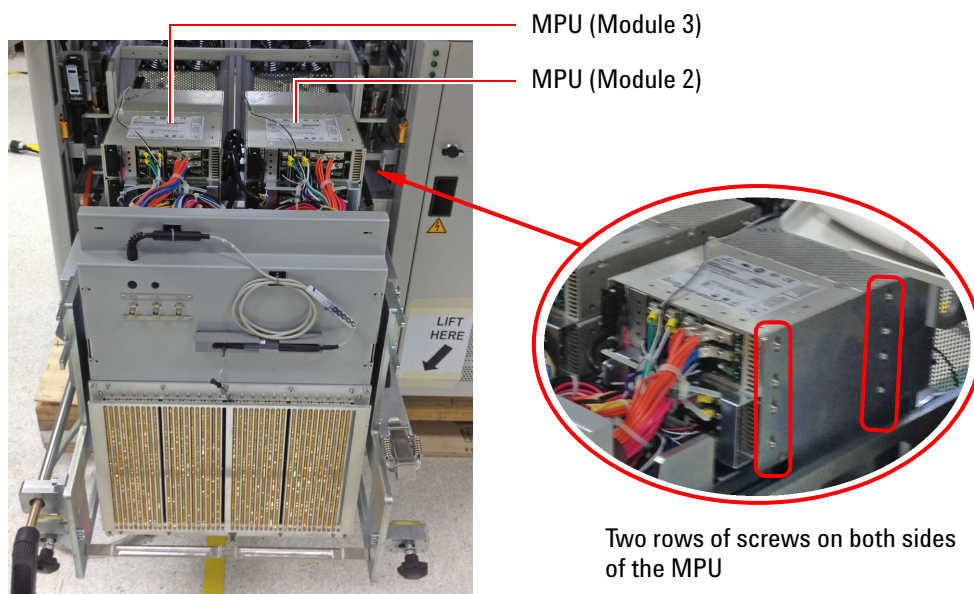

- 3 Disconnect the MPU cable from the motherboard and disconnect the power cable.

CAUTION

It is very easy to bend or damage the pins on the motherboard connector when removing the MPU cable. Unplug the connector carefully.

- 4 Use an Allen key to remove the screws holding the MPU to the support plates on both sides of the MPU.
- 5 Remove the MPU.

Installation

- 1 Secure the new MPU with the screws removed earlier.
- 2 Connect the MPU cable to the motherboard. Be sure to align the connectors properly.
- 3 Plug in the power cable.
- 4 Rotate the testhead back into position and stow the hand crank. Replace the guide bar and fasten the latches.
- 5 Push the testhead back into the system and tighten the star knobs.
- 6 Close all doors/covers.

Installing DUT Power Supply

Figure 7-7 DUT Power Supply in Controller Pod

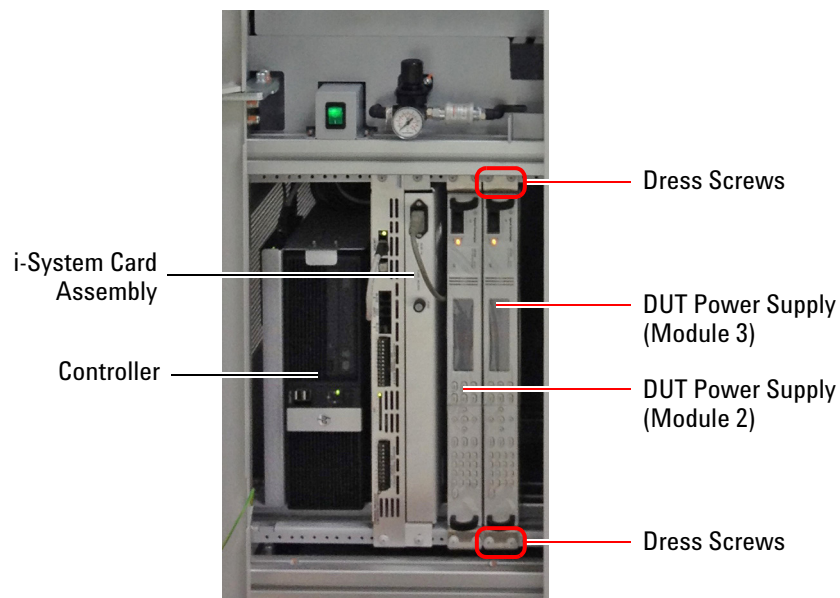

Installation

- 1 Open the controller pod door.
- 2 Slide the DUT power supply along the support rails into the system.
- 3 Secure it with four dress screws.

- 4 Open the rear door to connect the ground cable at the back of the DUT power supply.
- 5 Connect the cables F, G, H, and J.

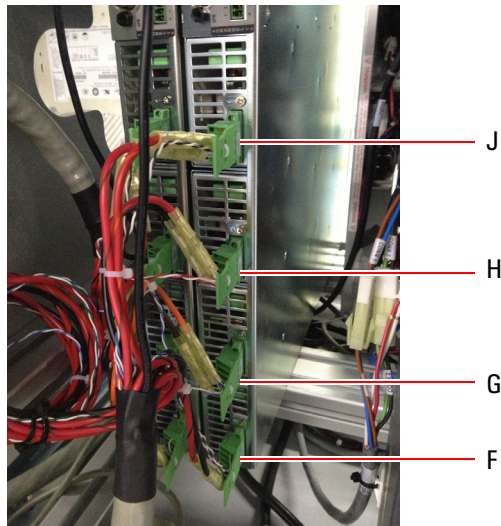
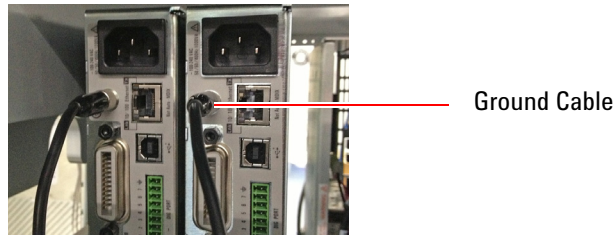

- 6 Tidy the unused cables (K and L) and secure with cable ties.
- 7 If two DUT power supplies are installed, connect the GPIB cable between the two GPIB ports.

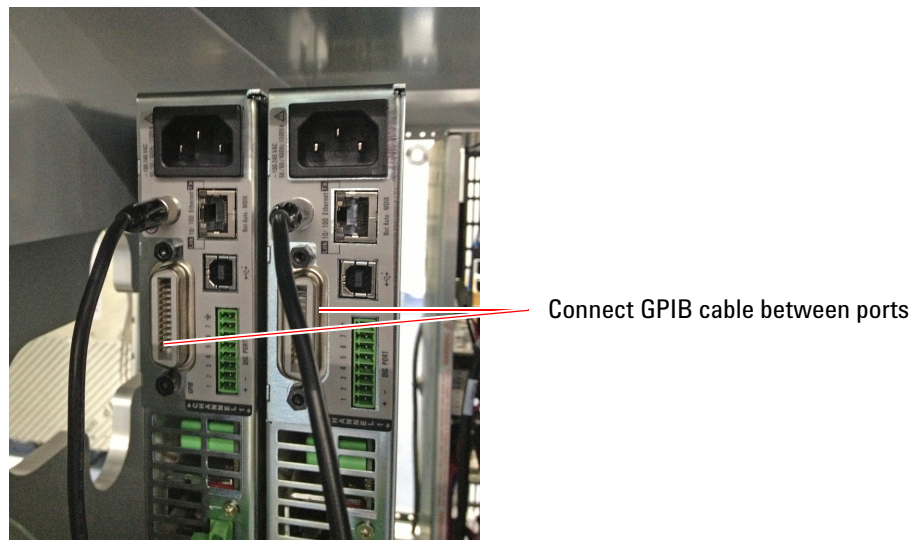

- 8 Connect the GPIB interface cable between the GPIB port on the DUT power supply and a USB port on the controller.

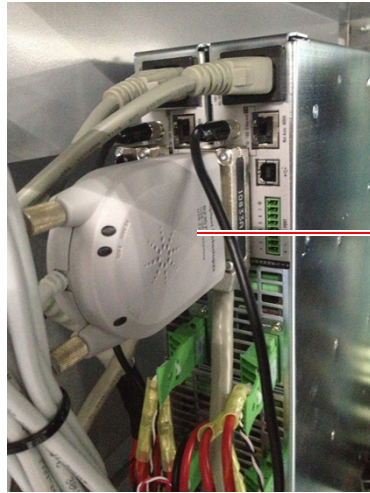

GPIB Interface Cable

- 9 Connect the AC power cord from the DUT power supply to the PDU outlet box.

Set the GPIB address

- 1 On the front panel of the DUT Power Supply, press the **Menu** button.
- 2 Press **▶** to select **System**, then press **Sel** to select **IO**.
- 3 Press **Sel** to select **GPIB**, and press **Sel** again to enter the GPIB address.
 - For module 2, GPIB address is **24**.
 - For module 2, GPIB address is **25**.
- 4 Launch **Agilent IO** to check that the GPIB addresses are set correctly.

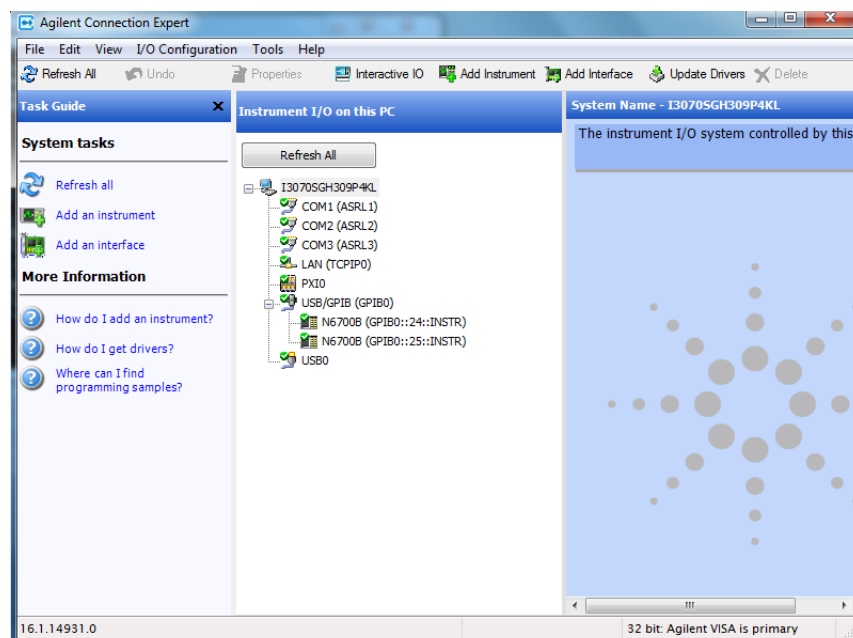

Update config Files

The power supply connections must be declared in the system and standard config files.

Example 7-1

```
bank 2
  module 2

      .....
supplies ps6751 5 to 8 asru channels 1 to 4
!     supplies hp6634 19 asru channels 5
!     supplies hp6634 20 asru channels 6
      ports ext3, ext4
      end module

      module 3
      .....
      supplies ps6751 1 to 4 asru channels 1 to 4
!     supplies hp6634 17 asru channels 5
!     supplies hp6634 18 asru channels 6
      ports ext1, ext2
      end module
end bank
```

Replacing Servo Motor

Safety Precautions for Removal

For your safety, follow these steps before removing the Press servo motor, coupling, and ballscrew. Power must be connected to begin this procedure.

- 1 Select **Maintenance** mode on the [LCD touch panel](#).
 - a Press **Presser** to go to page 6.
 - b Press **Origin** to move the Press to its origin position.
 - c Press and hold **Down** to move the Press down until the coupling can be accessed ([Figure 7-1](#)).

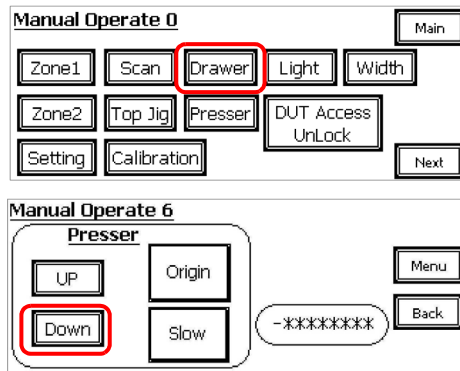
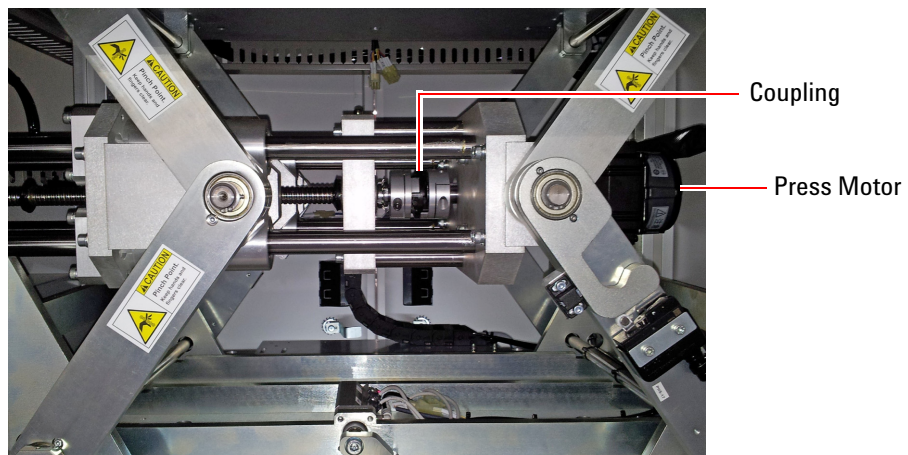
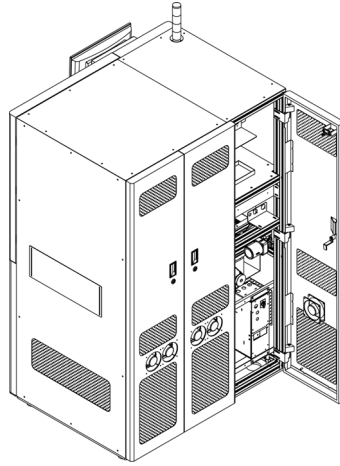

Figure 7-1 Press Coupling and Motor



- 2 Turn off the power and air supplies.

3 Open the rear door.



4 Loosen the two screws on the set collar and push the set collar against the linear bearing. Tighten the screws on the set collar.

Do the same for the other set collar.

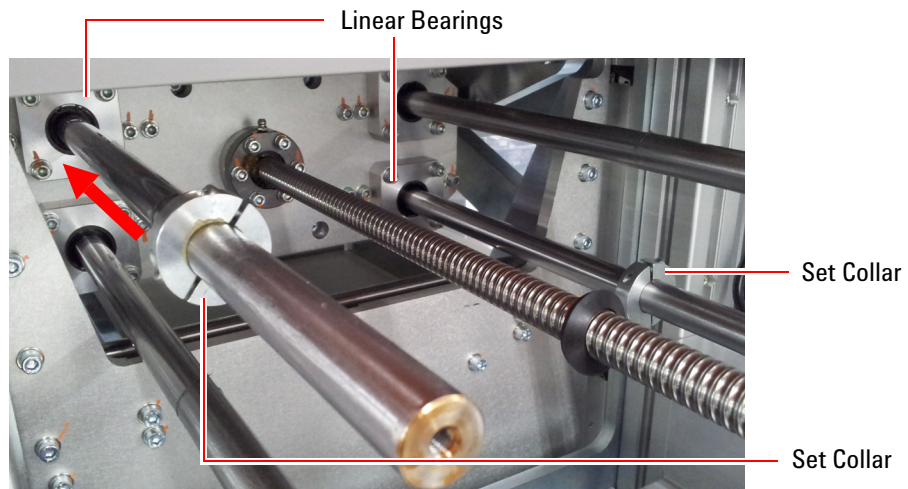

Remove Servo Motor

- 1 Open the Zone 2 door and remove the side cover.

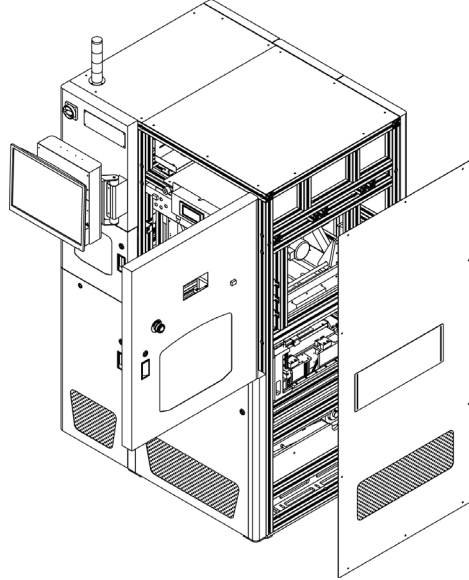

- 2 Remove the Press servo motor:
 - a Loosen the screw that secures the coupling to the motor shaft.
 - b Unplug the electrical connectors.
 - c Remove four screws securing the servo motor. The motor can now be removed.

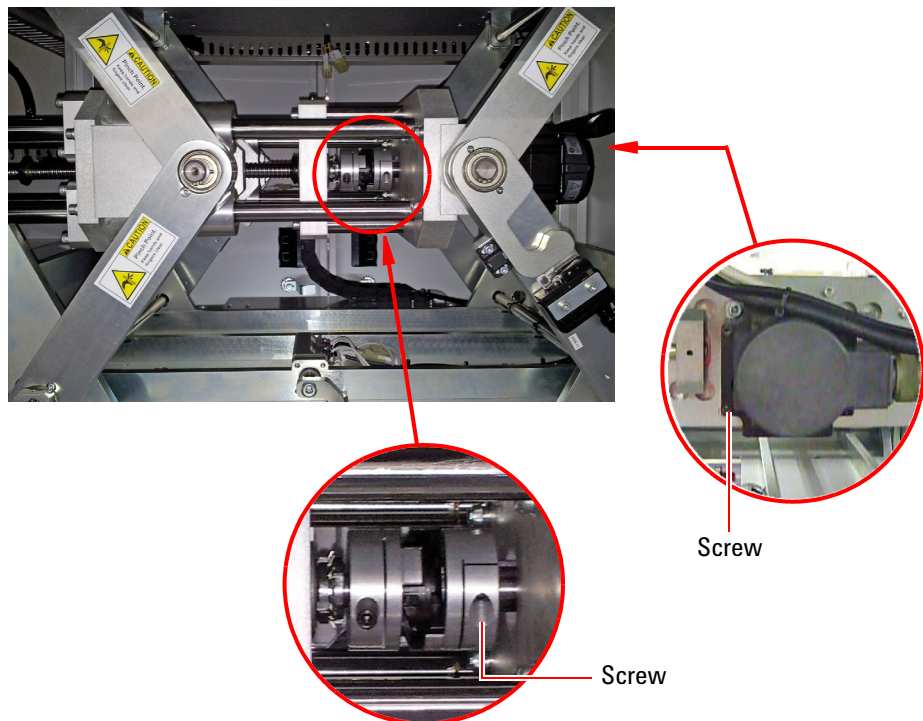

Install Servo Motor

- 3** Install the new servo motor. The shaft of the motor must be properly aligned for it to go into the coupling. Secure the motor with the four screws.
- 4** Plug in the electrical connectors.
- 5** Tighten the screw on the coupling.

Reposition Set Collars

- 6** Loosen the screws on the set collars and move them back into position, 30 mm to 50 mm from the end of the shaft. Tighten the screws on the set collars.
- 7** Close all doors.

Replacing Press Components

- Ballscrew
- Tapered roller bearing (on either side of the bearing block)
- Coupling

NOTE

Remove the fixture before replacing parts in the Press assembly.

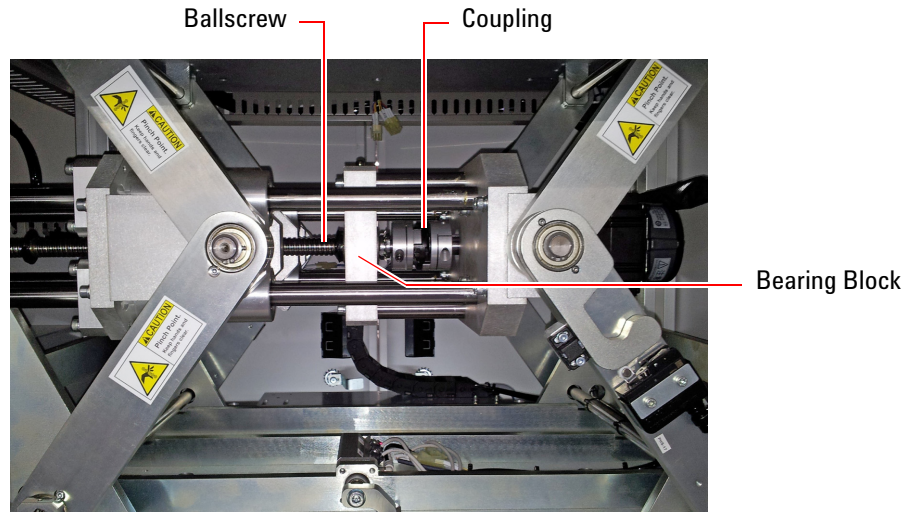

Tools required

- Metric Allen key
- Philips screwdriver
- Flat screwdriver
- Diagonal cutter
- C spanner

Removal

- 1 Follow the [Safety Precautions for Removal](#).
- 2 Open the Zone 2 door.
- 3 Loosen the screw securing the coupling to the ballscrew. Then loosen the locknuts.

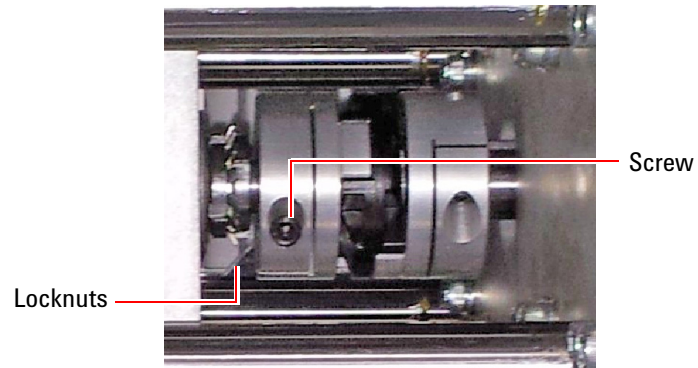

- 4 Remove four screws securing the bearing block.

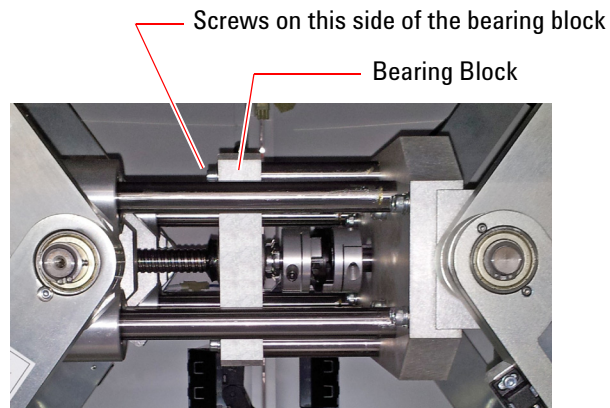

- 5 Remove six screws securing the ballscrew collar. The collar and ballscrew can now be removed.

Keep the rubber washer in place; it prevents the ballscrew nut from sliding off the ballscrew.

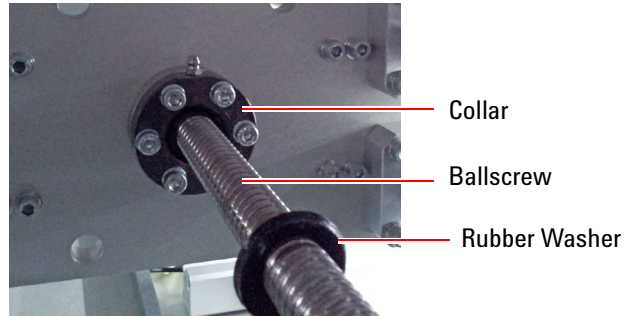

CAUTION

Do not drop the bearing block when removing the collar and ballscrew.

- 6** **If replacing the tapered roller bearing:** The bearing block is released and the tapered roller bearing can now be replaced.

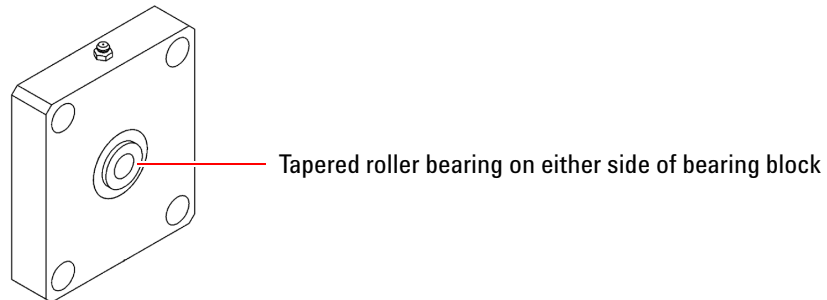

- 7** **If replacing coupling:** Loosen the screw securing the coupling to the servo motor shaft. The coupling can now be removed.
Replace with a new coupling and tighten the screw to secure it to the servo motor shaft.

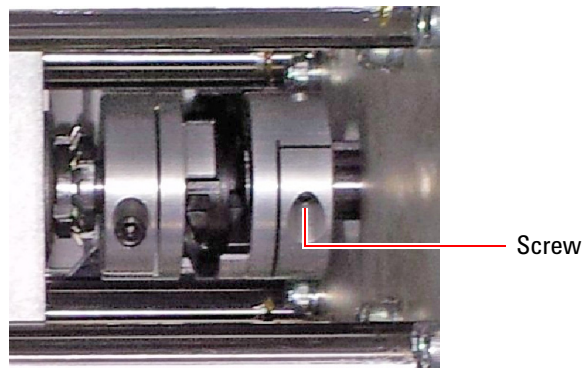

- 8** Insert the ballscrew through the collar and bearing block, ensuring that the roller bearings on both sides of the bearing block remain in place. Secure the collar with six screws.
- 9** Secure the bearing block with four screws.

- 10 Tighten the locknuts and the screw on the coupling.

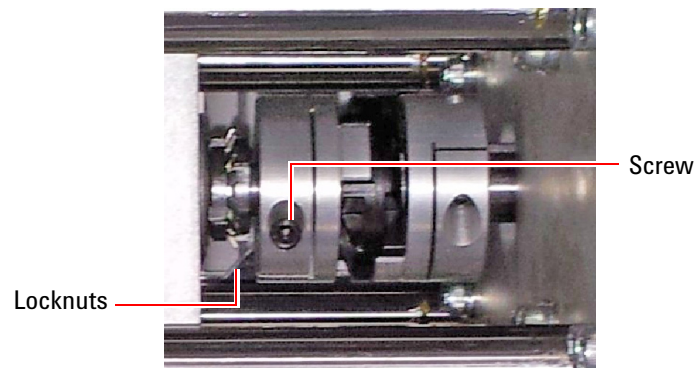

Reposition Set Collars

- 11 Loosen the screws on the set collars and move them back into position, 30 mm to 50 mm from the end of the shaft. Tighten the screws on the set collars.
- 12 Close all doors.

Replacing Zone 1 Conveyor Belt

- Zone 1 Conveyor Belt (Movable Side)
- Zone 1 Conveyor Belt (Fixed Side)

Zone 1 Conveyor Belt (Movable Side)

Removal

- 1 Open the Zone 1 door to access the access the Zone 1 conveyor assembly.

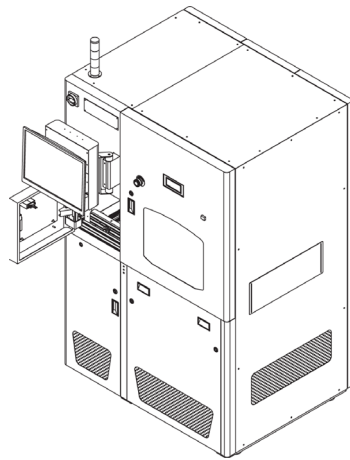

Zone 1 Conveyor Assembly

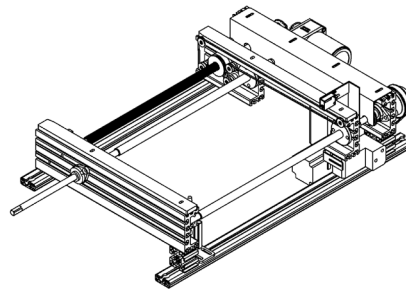

- 2 Loosen the screw on the tensioner bearing to release tension on the belt.
- 3 Slide the tensioner bearing in the direction shown to release the belt. Note how the belt is routed.

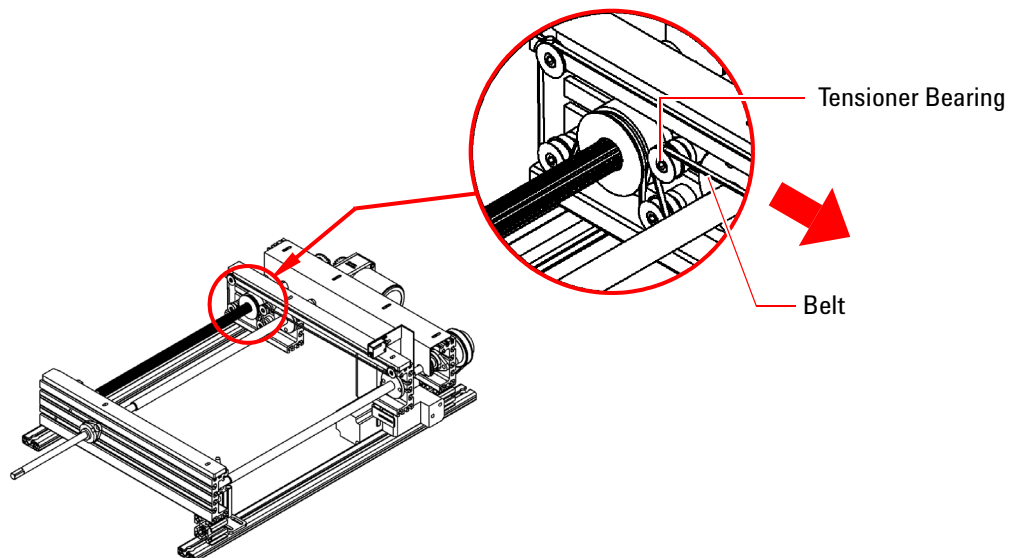

Installation

- 1 Install the new belt.
- 2 Slide the tensioner bearing in the direction shown and tighten the screw.

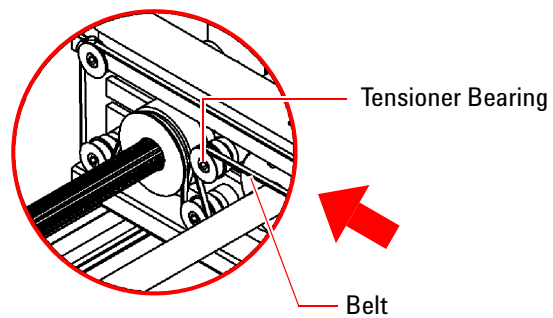

- 3 Close the door.

Zone 1 Conveyor Belt (Fixed Side)

Removal

- 1 Open the Zone 1 door to access the access the Zone 1 conveyor assembly.

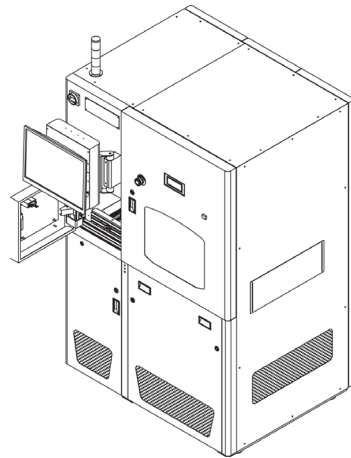

Zone 1 Conveyor Assembly

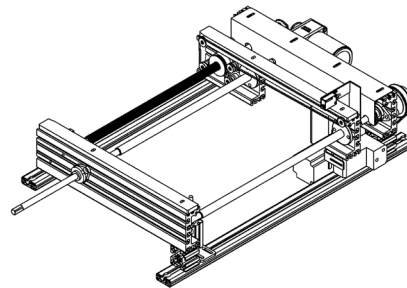

- 2 Loosen the screw on the tensioner bearing to release tension on the belt.
- 3 Slide the tensioner bearing in the direction shown and release the belt. Note how the belt is routed.

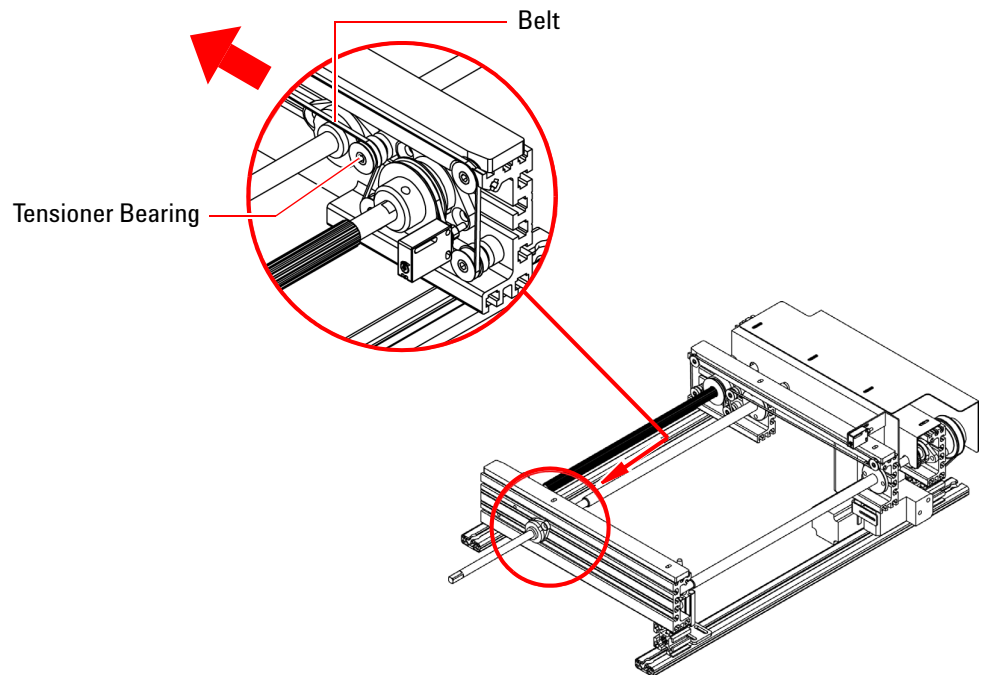

Installation

- 1 Install the new belt.
- 2 Slide the tensioner bearing in the direction shown and tighten the screw.

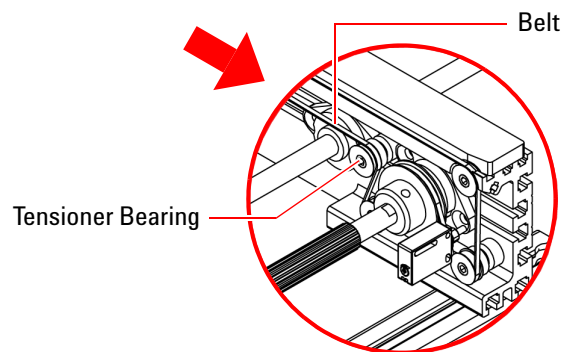

- 3 Close the door.

Replacing Zone 2 Conveyor Belt/Spring

- [Zone 2 Conveyor Belt \(Movable Side\)](#)
- [Zone 2 Conveyor Belt \(Fixed Side\)](#)
- [Compression Spring \(Movable Side\)](#)
- [Compression Spring \(Fixed Side\)](#)

Zone 2 Conveyor Belt (Movable Side)

Removal

- 1 Open the Zone 2 door to access the Zone 2 conveyor assembly.

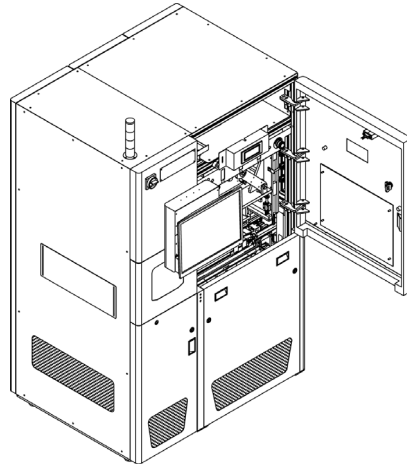

Zone 2 Conveyor Assembly

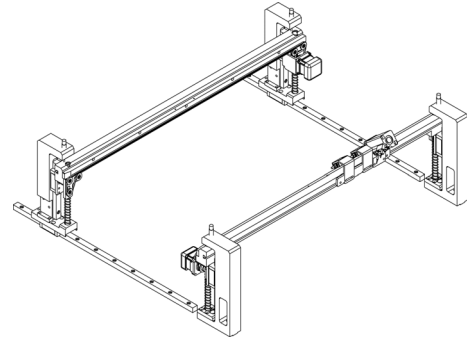

- 2 Loosen the screw on the tensioner bearing to release tension on the belt.
- 3 Slide the tensioner bearing in the direction shown and release the belt. Note how the belt is routed.

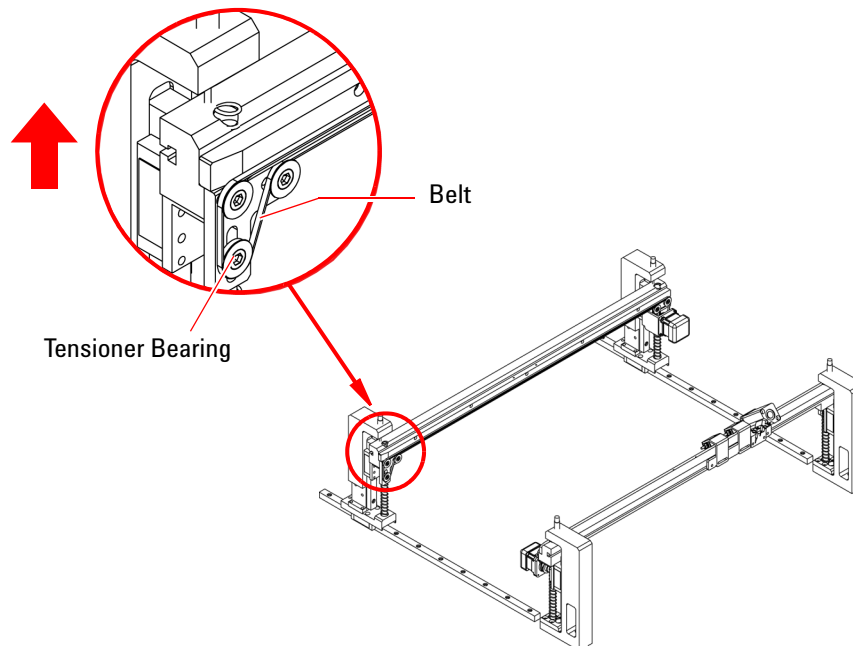

Installation

- 4 Install the new belt. Slide the tensioner bearing in the direction shown and tighten the screw.

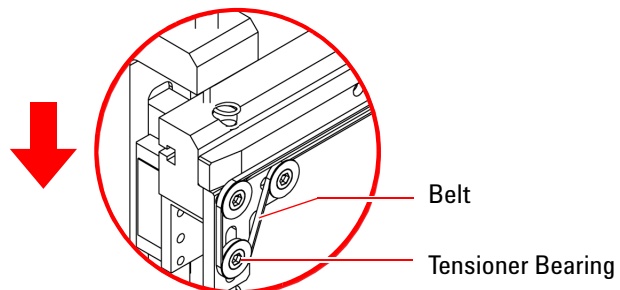

- 5 Close the door.

Zone 2 Conveyor Belt (Fixed Side)

Removal

- 1 Open the Zone 2 door to access the Zone 2 conveyor assembly.

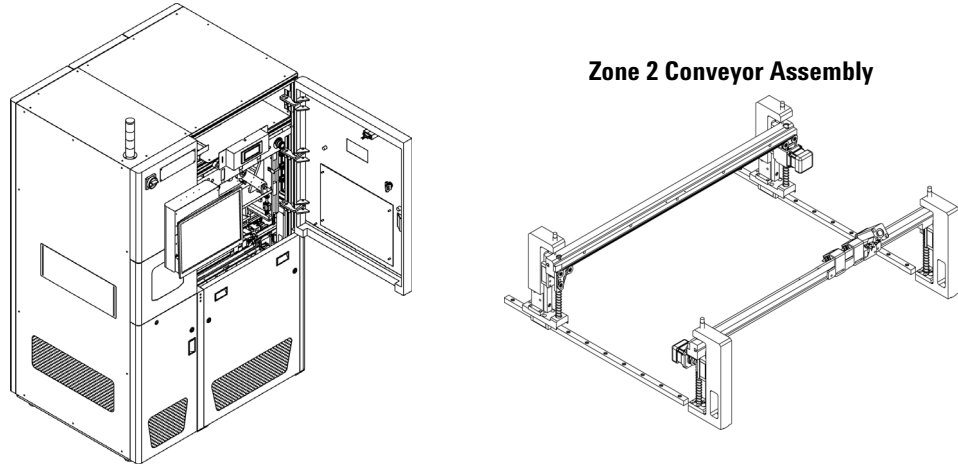

- 2 Loosen the screw on the tensioner bearing to release tension on the belt.
- 3 Slide the tensioner bearing in the direction shown and release the belt. Note how the belt is routed.

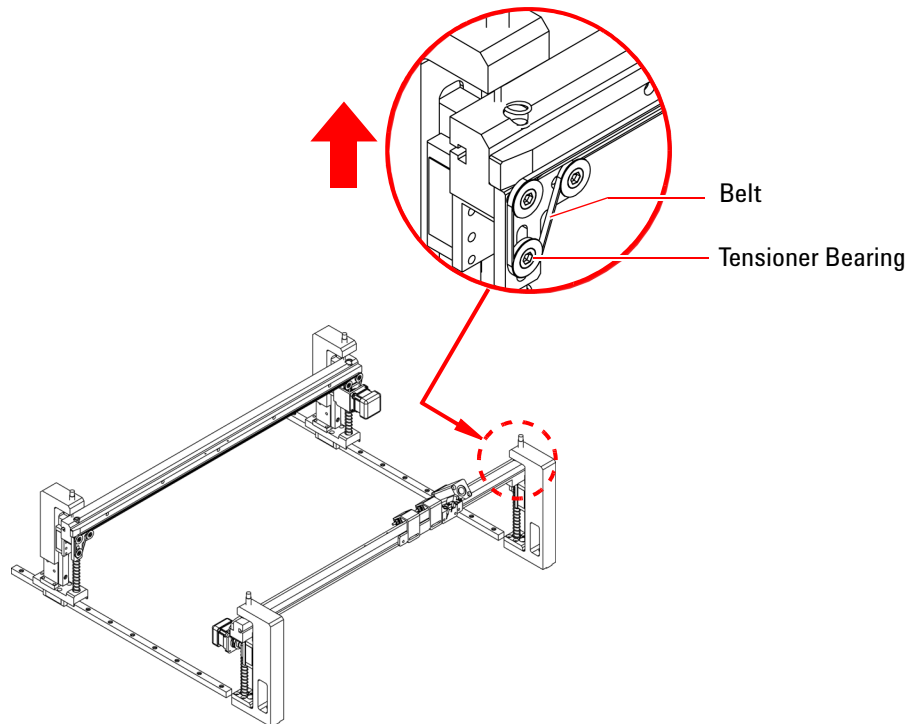

Installation

- 1 Install the new belt. Slide the tensioner bearing in the direction shown and tighten the screw.

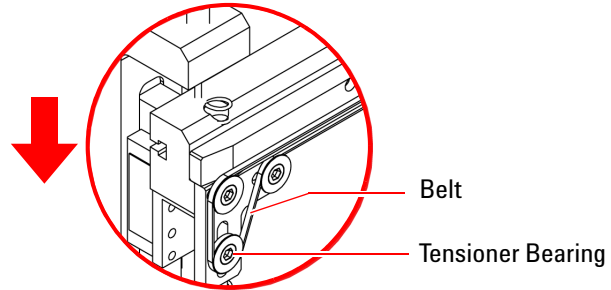

- 2 Close the door.

Compression Spring (Movable Side)

Follow this procedure to replace the springs for the Zone 2 conveyor (movable side).

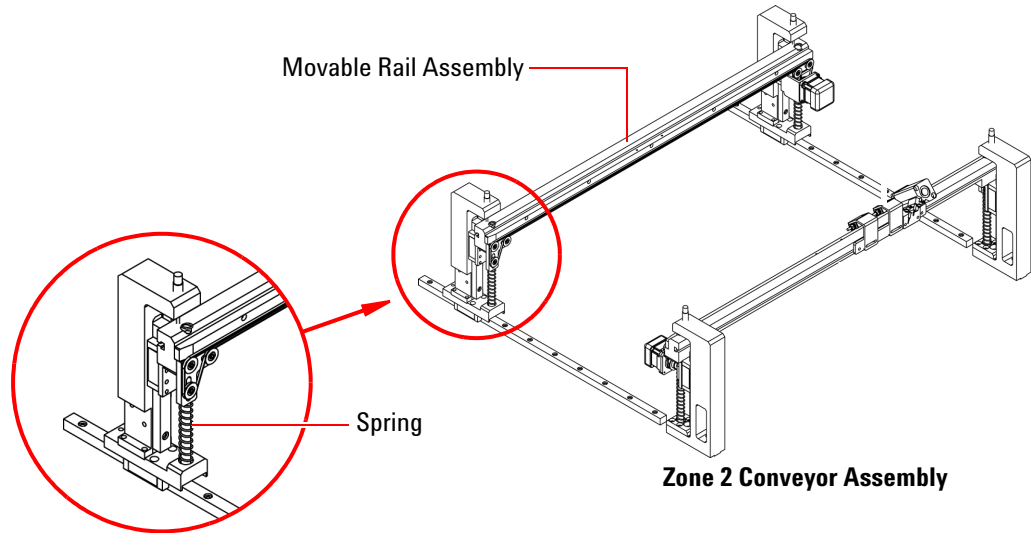

Removal

- 1 Remove the right side cover.
- 2 Remove the movable rail assembly:
 - a Remove six screws securing one side of the rail assembly.

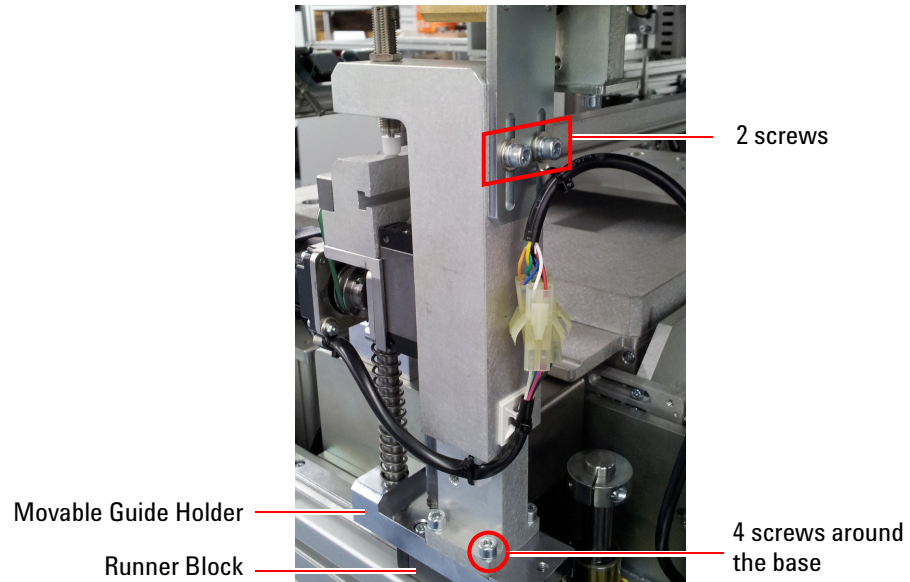

- b Do the same on the other side and remove the rail assembly.

- 3 The spring can now be removed.

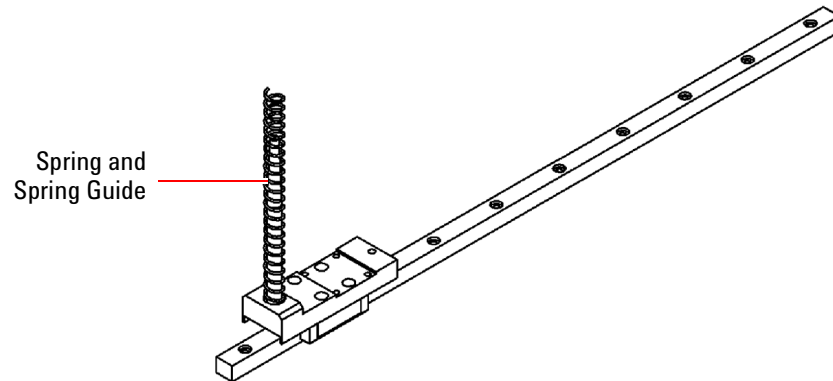

Installation

- 1 Insert the spring guide and new spring.
- 2 Reinstall the movable rail assembly. On each side, tighten the four screws at the base and make sure the rail assembly is properly aligned before tightening the two screws at the top.
- 3 Close all covers/doors.

Compression Spring (Fixed Side)

Follow this procedure to replace the springs for the Zone 2 conveyor (fixed side).

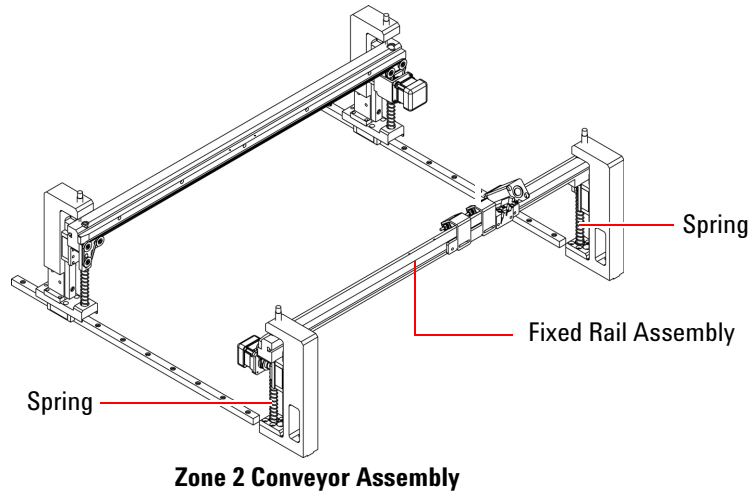

Removal

- 1 Remove the right side cover.
- 2 Remove the fixed rail assembly:
 - a Remove two screws securing one side of the rail assembly.

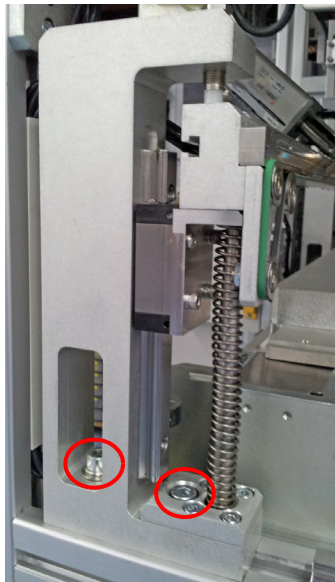

- b Do the same on the other side and remove the rail assembly.

- 3** To remove the spring from the fixed rail assembly:
 - a** Remove the screw securing the spring guide from below.
 - b** Remove four screws securing the support plate.

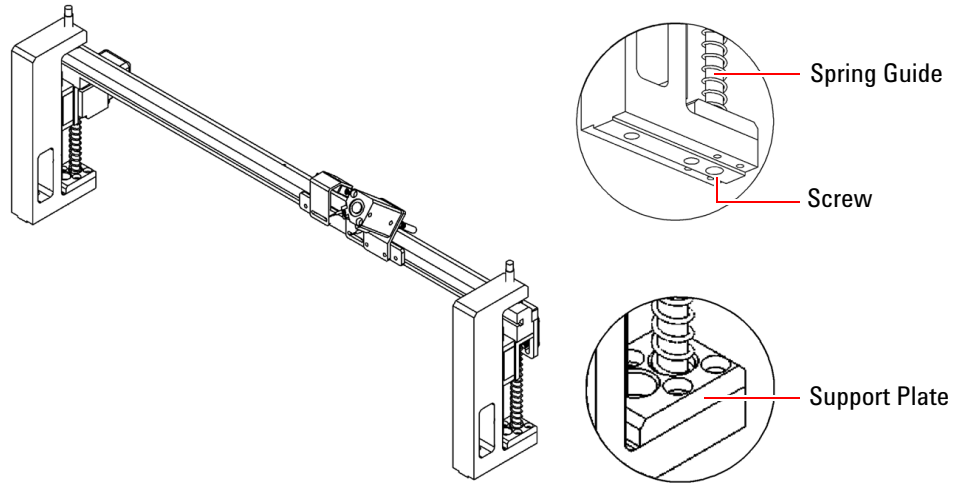

The support plate, spring, and spring guide can now be removed.

Installation

- 1** Assemble the new spring, spring guide, and support plate.
Secure the support plate to the rail assembly with four screws.
- 2** Secure the spring guide with one screw from below the assembly.
- 3** Install the fixed rail assembly in the system, securing it with two screws on either side.
- 4** Close all covers/doors.

Replacing Conveyor Motors

- Zone 1 Conveyor Motor
- Zone 2 Conveyor Motor (Movable Side)
- Zone 2 Conveyor Motor (Fixed Side)

Zone 1 Conveyor Motor

Removal

- 1 Open the rear door to access the Zone 1 conveyor assembly.

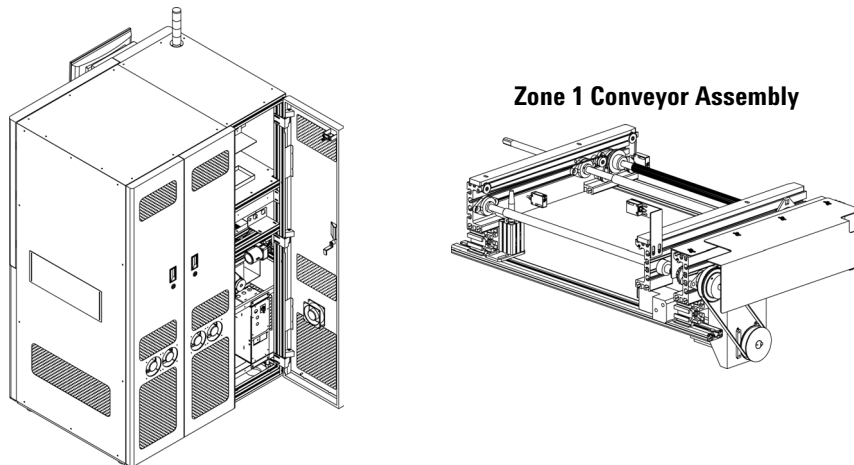

- 2 Remove three screws to remove the rear cover of the assembly.

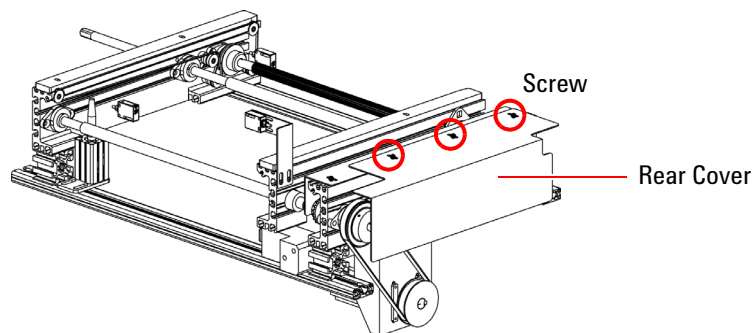

- 3** The conveyor motor is mounted on a bracket. Remove the two screws securing the bracket to the assembly.

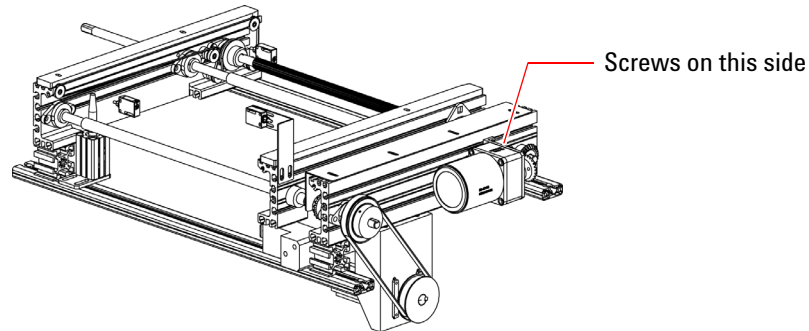

- 4** Remove the conveyor motor from the bracket:
 - a** Loosen two setscrews securing the bevel gear and remove the bevel gear.
 - b** Remove the four screws securing the conveyor motor to the bracket.

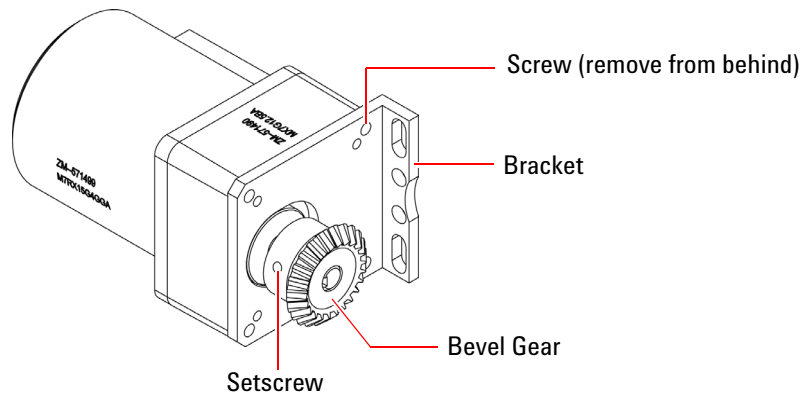

Installation

- 1** Install the new conveyor motor on the bracket:
 - a** Align the mounting holes and secure with the four screws.
 - b** Insert the bevel gear and tighten the setscrews.
- 2** Secure the conveyor motor bracket to the conveyor assembly with two screws. Ensure that the bevel gears mesh properly.
- 3** Install the rear cover over the motor and secure with three screws.
- 4** Close the rear door.

Zone 2 Conveyor Motor (Movable Side)

Removal

- 1 Follow the [Removal](#) instructions in [Zone 2 Conveyor Belt \(Movable Side\)](#) to remove the belt on the movable side of the Zone 2 conveyor.
- 2 Remove the four mounting screws securing the conveyor motor.

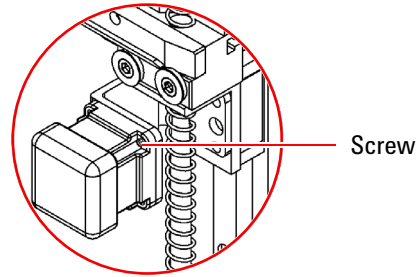

- 3 Loosen the two setscrews that mount the pulley on the conveyor motor and remove the pulley.

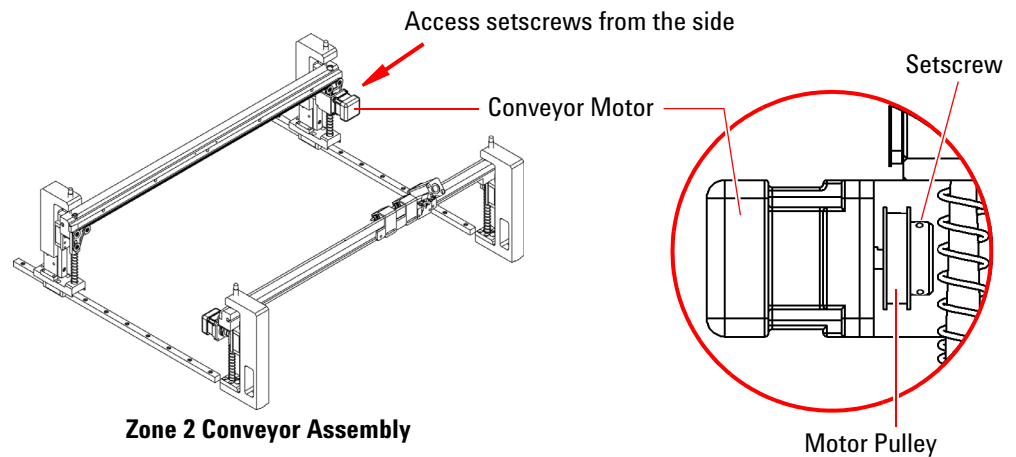

Installation

- 1 Install the pulley and tighten the setscrews. Ensure that the pulley is properly aligned.
- 2 Align the mounting holes and secure the new conveyor motor with four screws.
- 3 Follow the [Installation](#) instructions in [Zone 2 Conveyor Belt \(Movable Side\)](#) to complete the installation.

Zone 2 Conveyor Motor (Fixed Side)

Removal

- 1 Follow the [Removal](#) instructions in [Zone 2 Conveyor Belt \(Fixed Side\)](#) to remove the belt on the fixed side of the Zone 2 conveyor.
- 2 Loosen the two setscrews that mount the pulley on the conveyor motor and remove the pulley.

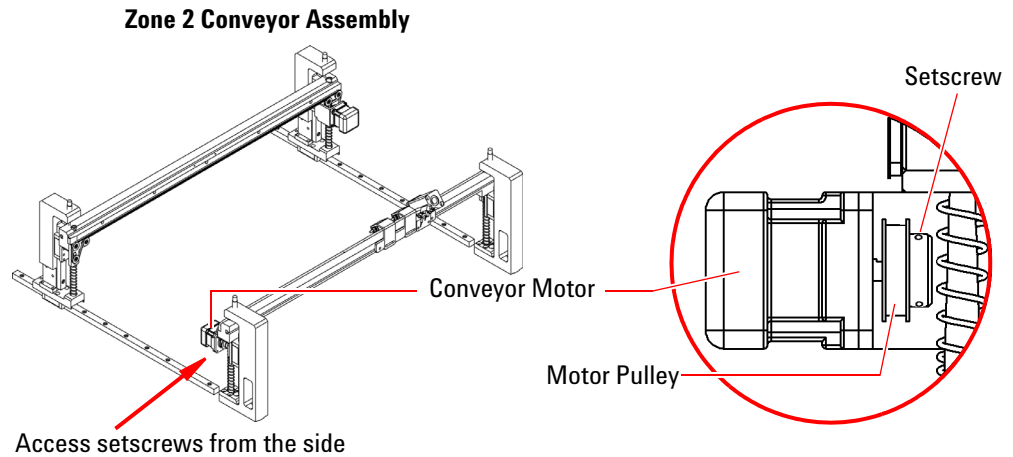

- 3 Remove the four mounting screws securing the conveyor motor.

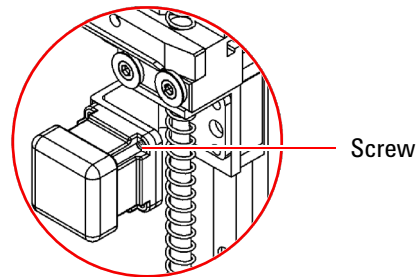

Installation

- 4 Align the mounting holes and secure the new conveyor motor with four screws.
- 5 Insert the pulley and tighten the setscrews. Ensure that the pulley is properly aligned.
- 6 Follow the [Installation](#) instructions in [Zone 2 Conveyor Belt \(Fixed Side\)](#) to complete the installation.

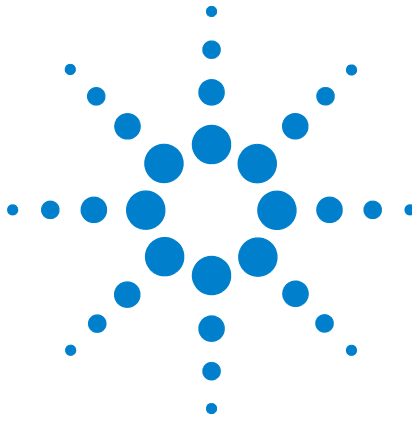

8 Firmware Update

Update PLC Firmware [8-2](#)

Back Up PLC Firmware [8-4](#)

Update LCD Touch Panel Firmware [8-5](#)

Back Up LCD Touch Panel Firmware [8-6](#)

If a firmware update is available, the files must be copied to a memory card for transfer to the Medalist i3070 Series 5i.

- PLC: Use a Compact Flash (CF) card (maximum 2 GB).
- LCD touch panel: Use an SD card (maximum 16 GB).

You can also back up the firmware from the system to a memory card.



Update PLC Firmware

- 1 Open the Zone 2 door to access the PLC.

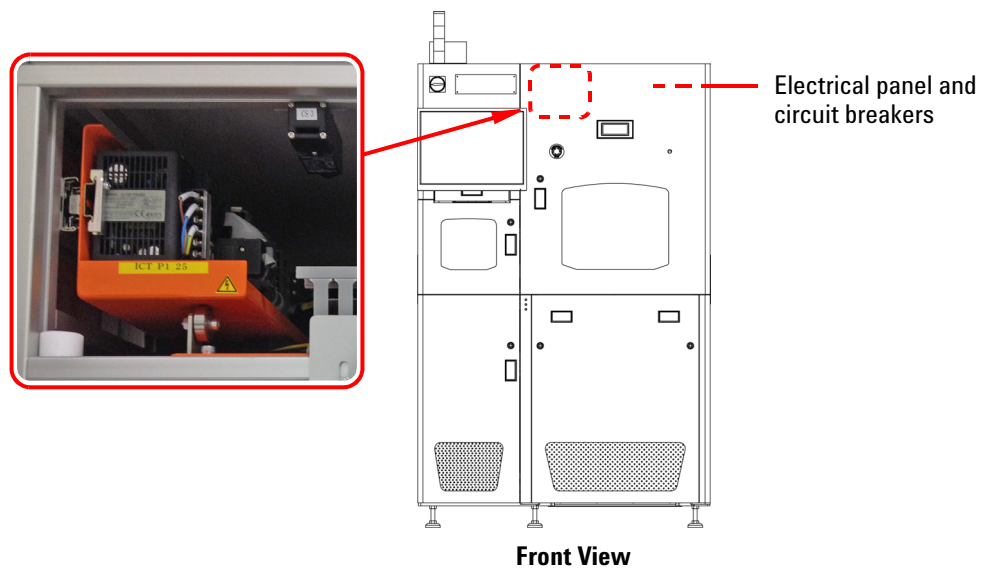

- 2 Turn off the power to the PLC by switching off MCB4 (Main Circuit Breaker 4) which is found on the electrical panel.
- 3 Open the cover of the memory card slot on the PLC and insert the memory card into the slot.

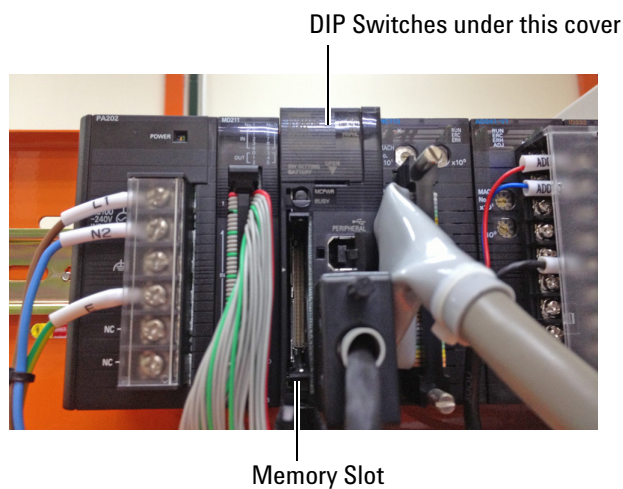

- 4 Open the cover above the memory slot to access the DIP switches.

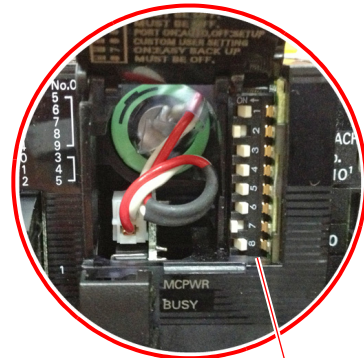

DIP Switches

- 5 Turn on DIP switch 2 and 7.

- 6 Switch on MCB4.

The program is automatically downloaded to the PLC.

- 7 Wait for the **BUSY** and **MCPWR** lights to go off, then turn the PLC power off.

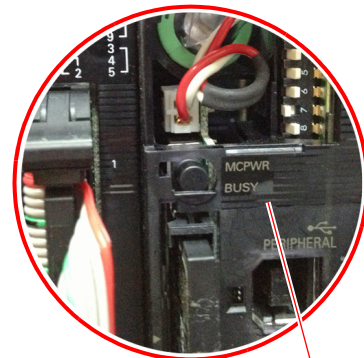

Lights

- 8 Turn off DIP switches 2 and 7.

- 9 Remove the memory card and replace all covers.

Back Up PLC Firmware

- 1 Switch off MCB4.
- 2 Open the cover of the memory card slot on the PLC and insert the memory card into the slot.

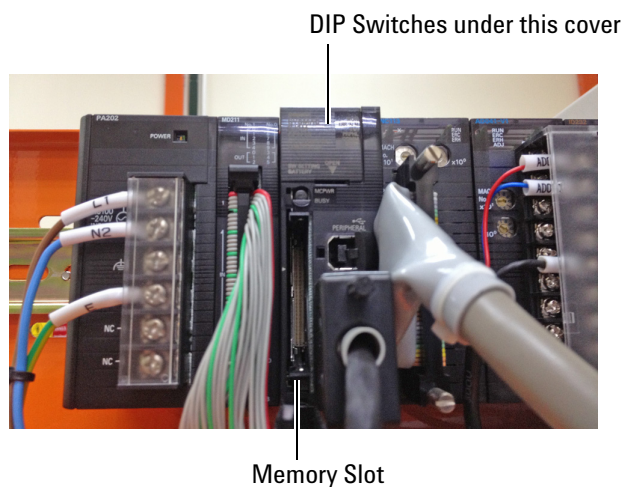

- 3 Open the cover above the memory slot to access the DIP switches.



- 4 Turn on DIP switch 7.
- 5 Press and hold the **MCPWR** button until the **BUSY** light starts blinking.
- 6 Wait for the **BUSY** light to go off, then switch off MCB4.
- 7 Turn off DIP switch 7.
- 8 Remove the memory card and close all covers.

Update LCD Touch Panel Firmware

- 1 Copy the entire folder (gt_data) containing the firmware update to an SD card.

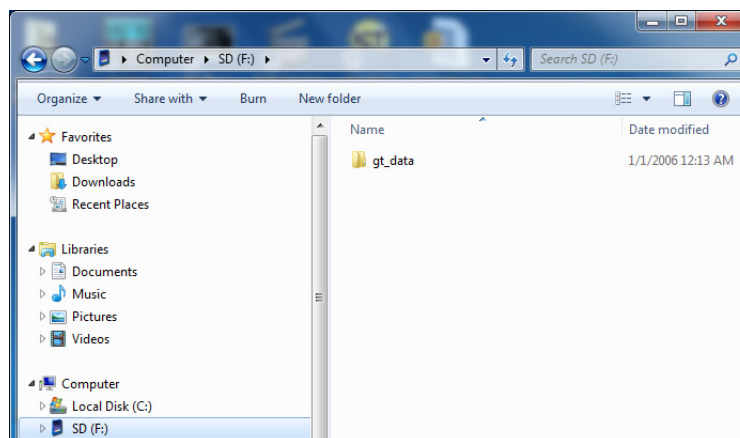

- 2 Open the Zone 2 door. Insert the SD card into the card slot.



- 3 On the Setting Mode page, select **SD** → **GT**.



- 4 Select the folder to download and press **Copy**.
- 5 Press **OK** to start the update.

- 6 Press **OK** when completed. Remove the SD card and press **ESC** to return to the Main menu.

Back Up LCD Touch Panel Firmware

- 1 Open the Zone 2 door. Insert the SD card into the card slot.
- 2 On the Setting Mode page, press **Manual** to switch to **Automatic** mode.

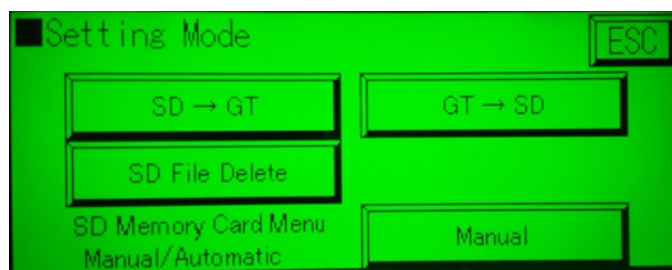

- 3 To back up the firmware, select **GT → SD**.
- 4 Enter a filename for the backup and press **ENT**.

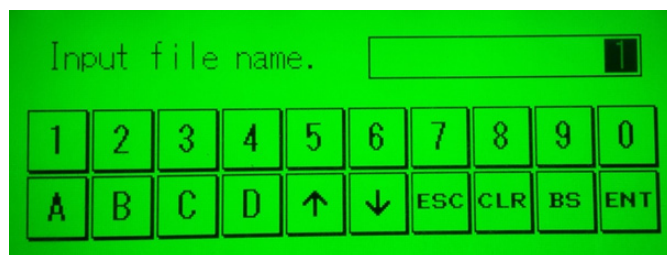

- 5 Press **OK** to confirm.
- 6 When the backup is completed, press **OK**. Remove the SD card and press **ESC** to return to the Main menu.

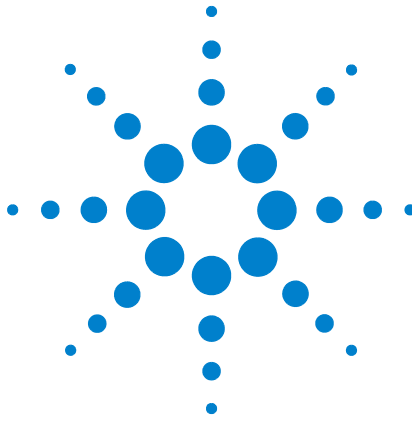

Appendix

Parts List 9-2

Electrical Diagrams 9-5



Parts List

Table 9-1 Parts (Level 1)

Part Number	Description	Qty	Category	Sub-category
E9988-21201	Motor Coupling, Oldham Coupling ID15K5 and ID19K6	1	Top Press	Servo System
0490-2998	Switch-Reed 40mA 24VAC with Light indicator	2	Top Press	Top Fixture Clamp
E9988-33602	TU-6 3MM ENDLESS BELT 1000MM	2	Zone 1 Conveyor	Rail Assy
5186-2230	Reed Switch_24VDC/100VAC	2	Zone 1 Conveyor	Rail Assy
0960-3187	Sensor Background suppression w/2m fixed Cable	3	Zone 1 Conveyor	Rail Assy
E9988-33601	TU6 3MM ENDLESS BELT L1670	2	Zone 2 Conveyor	Rail Assy
5186-2230	Reed Switch_24VDC/100VAC	2	Zone 2 Conveyor	Rail Assy
0960-3187	Sensor Background suppression w/2m fixed Cable	4	Zone 2 Conveyor	Rail Assy
0950-5621	Power Supply switching AC-DC 150W 1-Output	2	Electrical Panel	24VDC
0490-2999	Relay-Module 24VAC 75X110X22.5-mm	1	Electrical Panel	24VDC
0490-3000	Relay 2C 24VDC-Coil 10A 250VAC 636-Ohm 21.5X28X36-mm	2	Electrical Panel	24VDC
0490-3001	Relay 4PDT 24VDC-Coil 5A 250VAC 636-Ohm 21.5X28X36-mm	2	Electrical Panel	24VDC
0490-3002	Relay SPDT 24VDC-Coil 21.8mA 250VAC 1100-Ohm plug-in 29X13X29-mm	12	Electrical Panel	24VDC
2140-0827	Bulb 220V 10W white	3	M/C Panel	Top
3131-0696	Switch-Part Pushbutton LED Lamp White	5	Interface Panel	24VDC

Table 9-2 Parts (Level 2)

Part Number	Description	Qty	Category	Sub-category
1990-4262	Photomicrosensor GaAs infrared 940-nm-Peak wavelength NPN L-Shape	4	Top Press	Servo System
3101-4356	Switch-push Button SPDT 15A 500VAC Screw Mount	2	Top Press	Press Safety Lock
1990-4262	Photomicrosensor GaAs infrared 940-nm-Peak wavelength NPN L-Shape	3	Zone 1 Conveyor	Width Adjustment
0950-5668	Power Supply AC/DC 14W 2-output 5/24VDC	1	Electrical Panel	PLC
0960-3183	Programmable Logic Controller	1	Electrical Panel	PLC
0960-3185	Programmable Logic Controller	1	Electrical Panel	PLC
0960-3186	Position Control Unit 31X66.5X92.97-mm	1	Electrical Panel	PLC
0950-5669	I/O Unit 4-Analog-Inputs 65X31X90-mm	1	Electrical Panel	PLC
0960-3184	Programmable Logic Controller	2	Electrical Panel	PLC
0960-3189	Output Unit-Relay Contact 16-Outputs	3	Electrical Panel	PLC
0960-3188	Serial Communications Unit with two RS-232C ports	1	Electrical Panel	PLC
9135-6165	Filter-Line Module 60Hz-MAX 520VAC 16A Panel-mount	1	Electrical Panel	220 VAC
3105-1131	Circuit Breaker miniature 4-Pole 25A 440VAC	1	Electrical Panel	220 VAC
2110-1572	Fuse 2A 500V fast-acting 10X38-mm Cartridge	1	Electrical Panel	220 VAC
2110-1573	Fuse 6A 500VAC 38X10.3-mm	2	Electrical Panel	220 VAC
1200-4674	Socket-Relay 2-Poles 23X76X31-mm DIN-track/Screw mounting	2	Electrical Panel	24VDC
1200-4672	Socket-Relay 4-Poles DIN-track/Screw mounting	2	Electrical Panel	24VDC
1200-4673	Socket-Relay 5-POS 90.5X16X61-mm screw-terminal	12	Electrical Panel	24VDC
0490-3015	Relay 1A 24VDC-Coil 10.5mA 30VDC 1.14K-Ohm panel-mount 72.5x33x32mm	4	Electrical Panel	24VDC
3101-4355	Switch-push Button SPST alternating 1A 240V panel	1	Interface Panel	24VDC
3101-4358	Switch-push Button SPST momentary 0.5A 240VAC/DC White illuminated panel-mount	4	Interface Panel	24VDC

Table 9-2 Parts (Level 2)

Part Number	Description	Qty	Category	Sub-category
2090-1086	Display-LCD 4.6-in Monitor with Touchscreen 320x120-Pixels 146X74X30-mm	1	Interface Panel	24VDC
3101-4357	Switch-push Button SPDT momentary 0.5A 240VAC/DC Blue illuminated panel-mount	1	Interface Panel	24VDC
3130-1520	Switch-Guard push-Button rectangular	1	Interface Panel	24VDC
3101-4359	Switch-push Button emergency stop Pushlock Pull/Turn Reset Red	1	Interface Panel	24VDC
3100-3744	Switch-Rotary-Key lock DPST 70DEG N.O-N.C 2-POS Flat-Key	1	Interface Panel	24VDC
3160-4462	Fan-Tubeaxial 24-VDC 4000-RPM 190-CFM 59-dBA 120X120X38-mm Plastic		M/C Panel	Rear



Appendix

Electrical Diagrams 9-2

Electrical Diagrams

- Sensor Layout 1
- Sensor Layout 2
- Sensor Layout 3
- Sensor Layout 4
- Power Circuit 1
- Power Circuit 2
- Power Circuit 3
- Power Circuit 4
- Power Circuit 5
- Pneumatic 1
- Pneumatic 2
- Pneumatic 3
- PLC Input Unit (Channel 0)
- PLC Input Unit (Channel 1)
- PLC Input Unit (Channel 2)
- PLC Input Unit (Channel 3)
- PLC Input Unit (Channel 4)
- PLC Output Unit (Channel 10)
- PLC Output Unit (Channel 11)
- PLC Output Unit (Channel 12)
- Motor and Communication
- PLC to PC Interface
- Interfacinng Cables
- SMEMA Communication
- Touch Panel
- Servo Motor
- Servo Pin Connection
- Analog Card Interface
- Stepper Motor

Figure 9-1 Sensor Layout 1

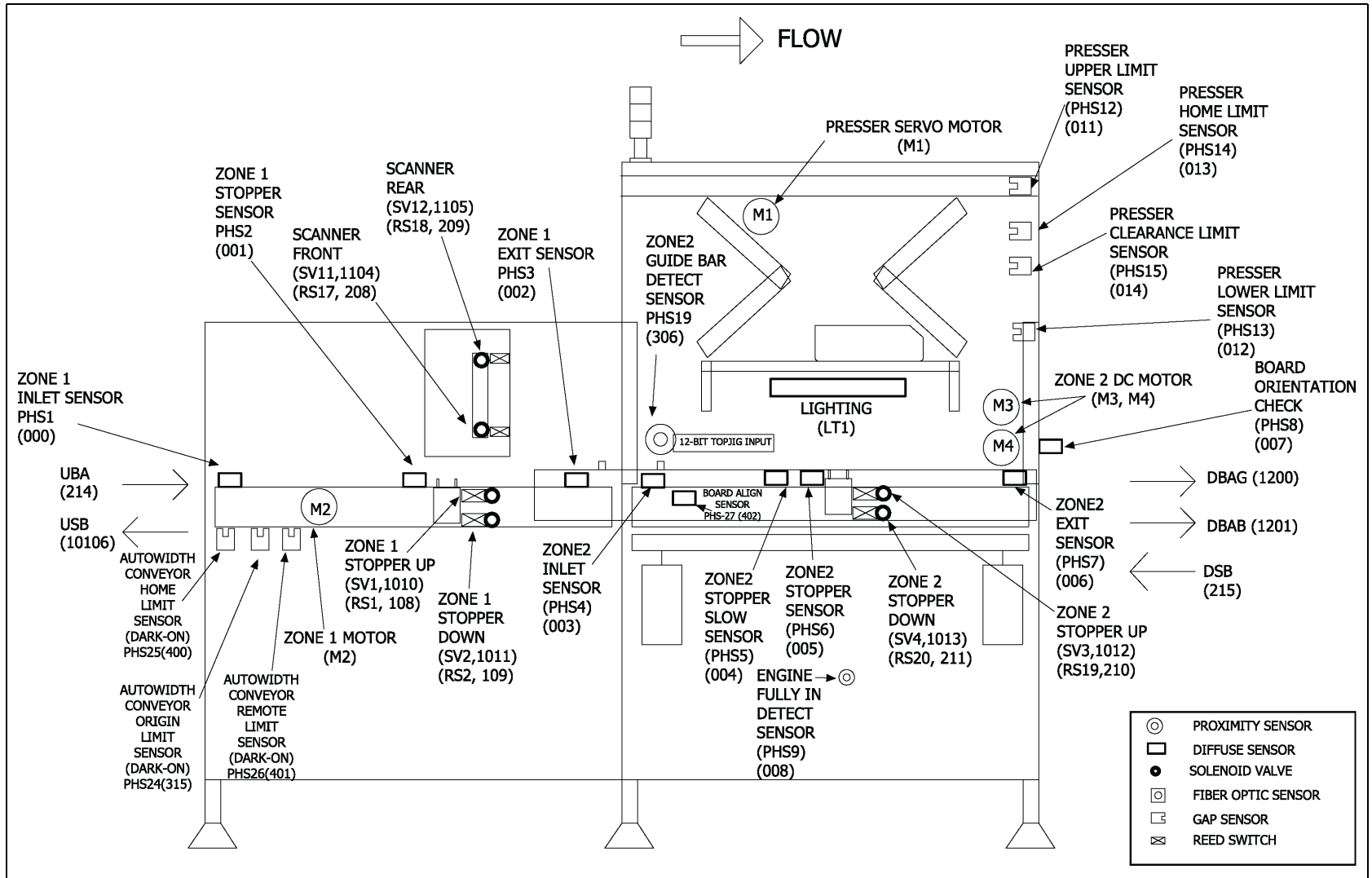

Figure 9-2 Sensor Layout 2

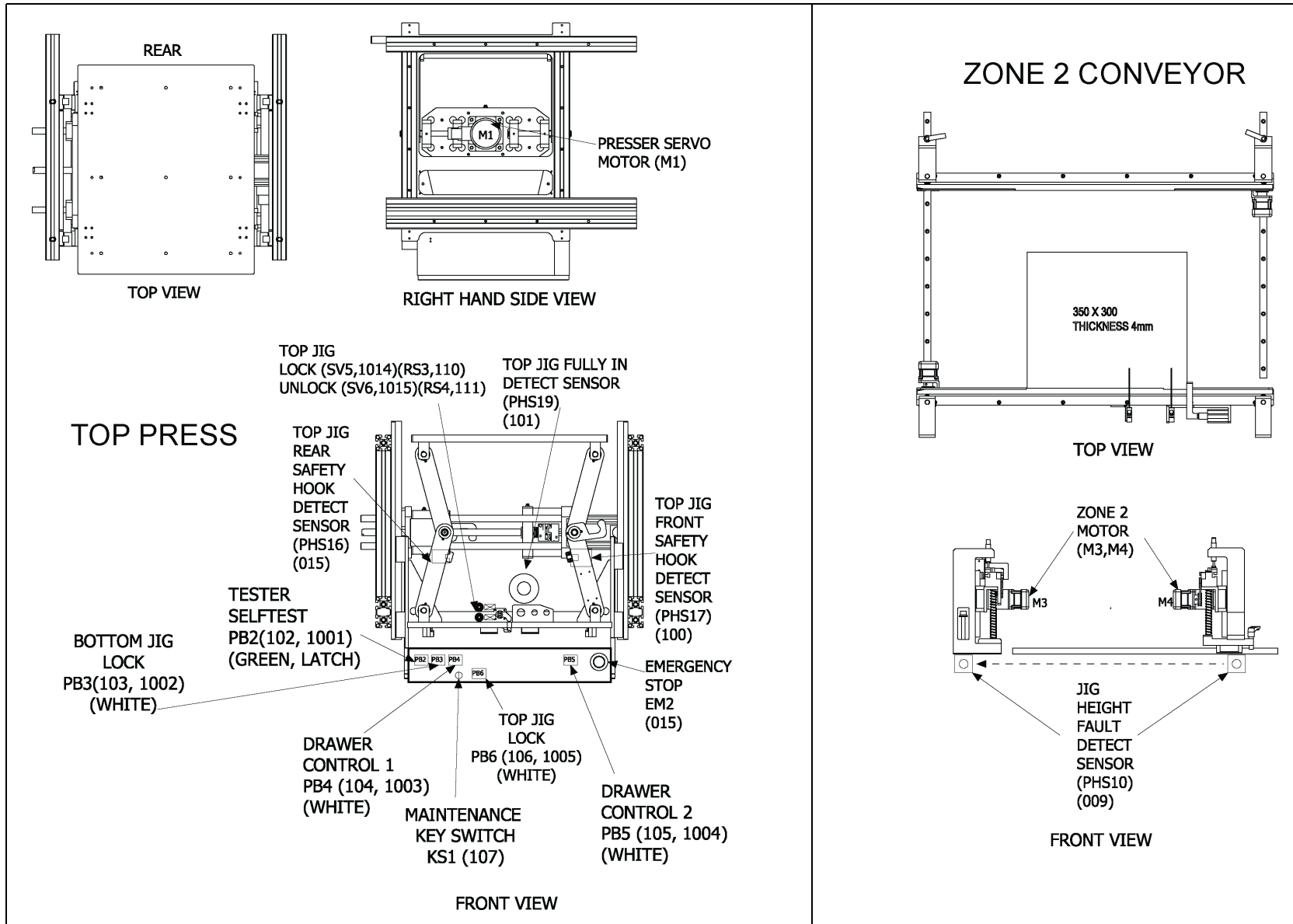

Figure 9-3 Sensor Layout 3

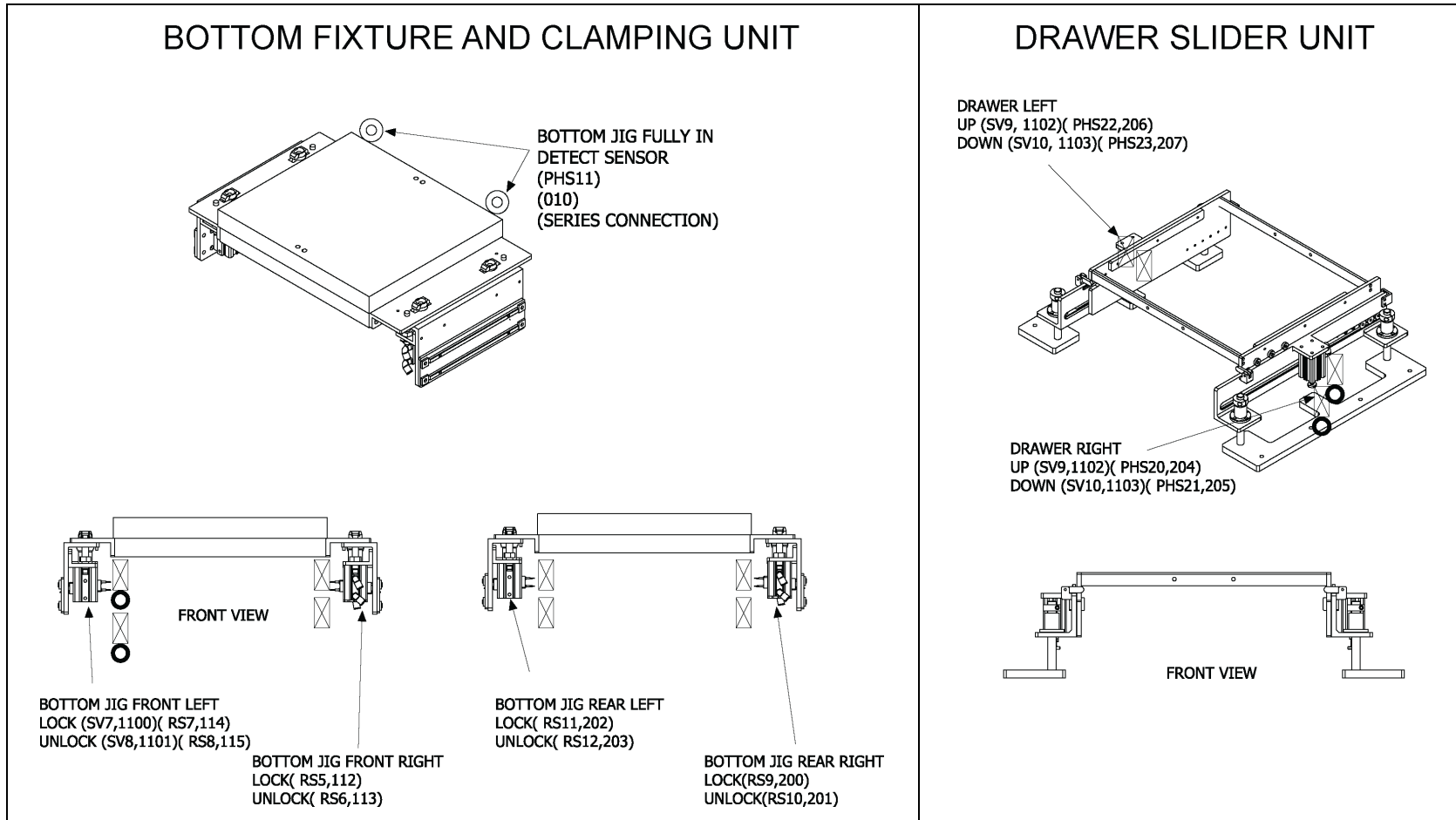

Figure 9-4 Sensor Layout 4

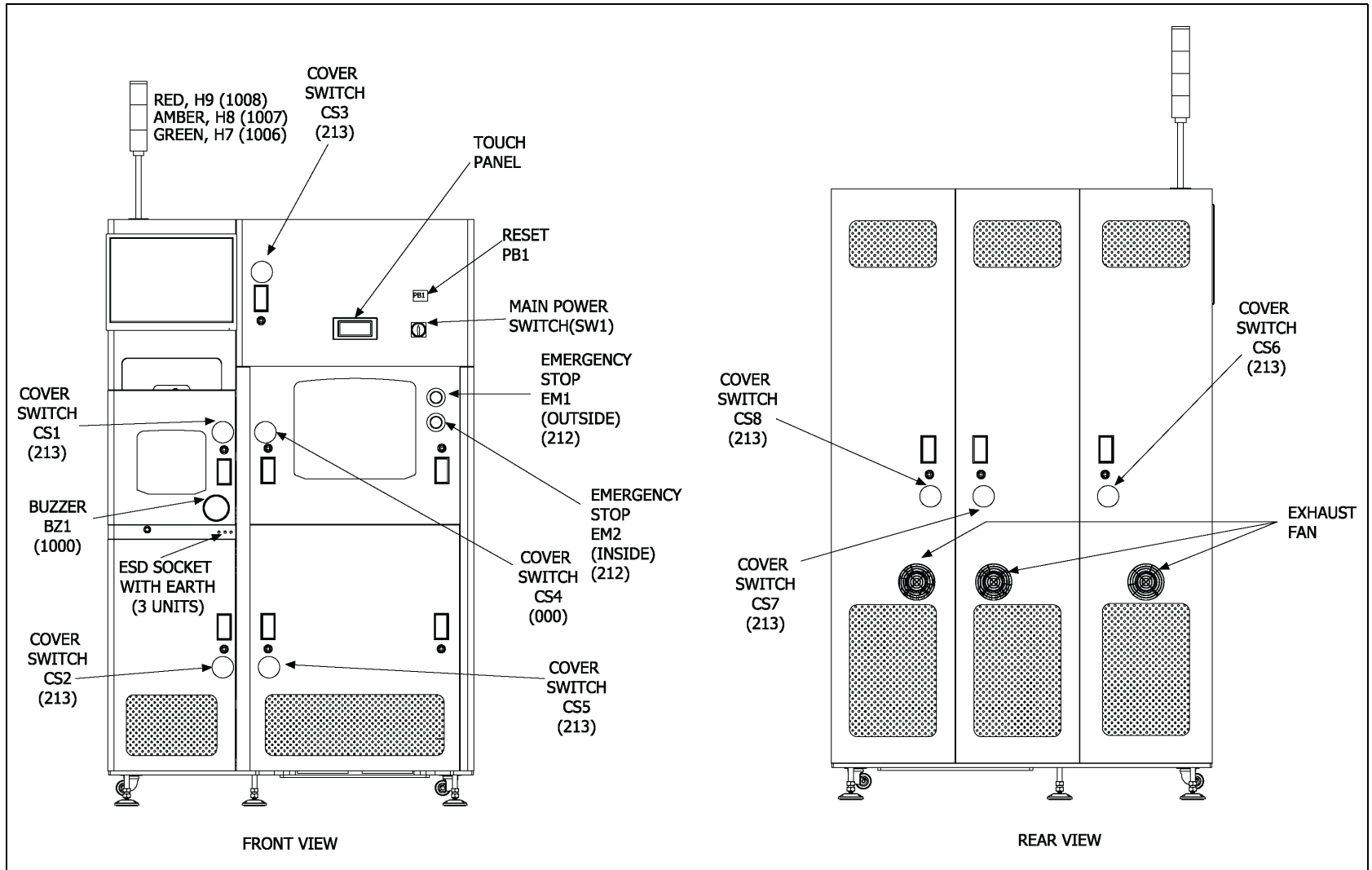

Figure 9-5 Power Circuit 1

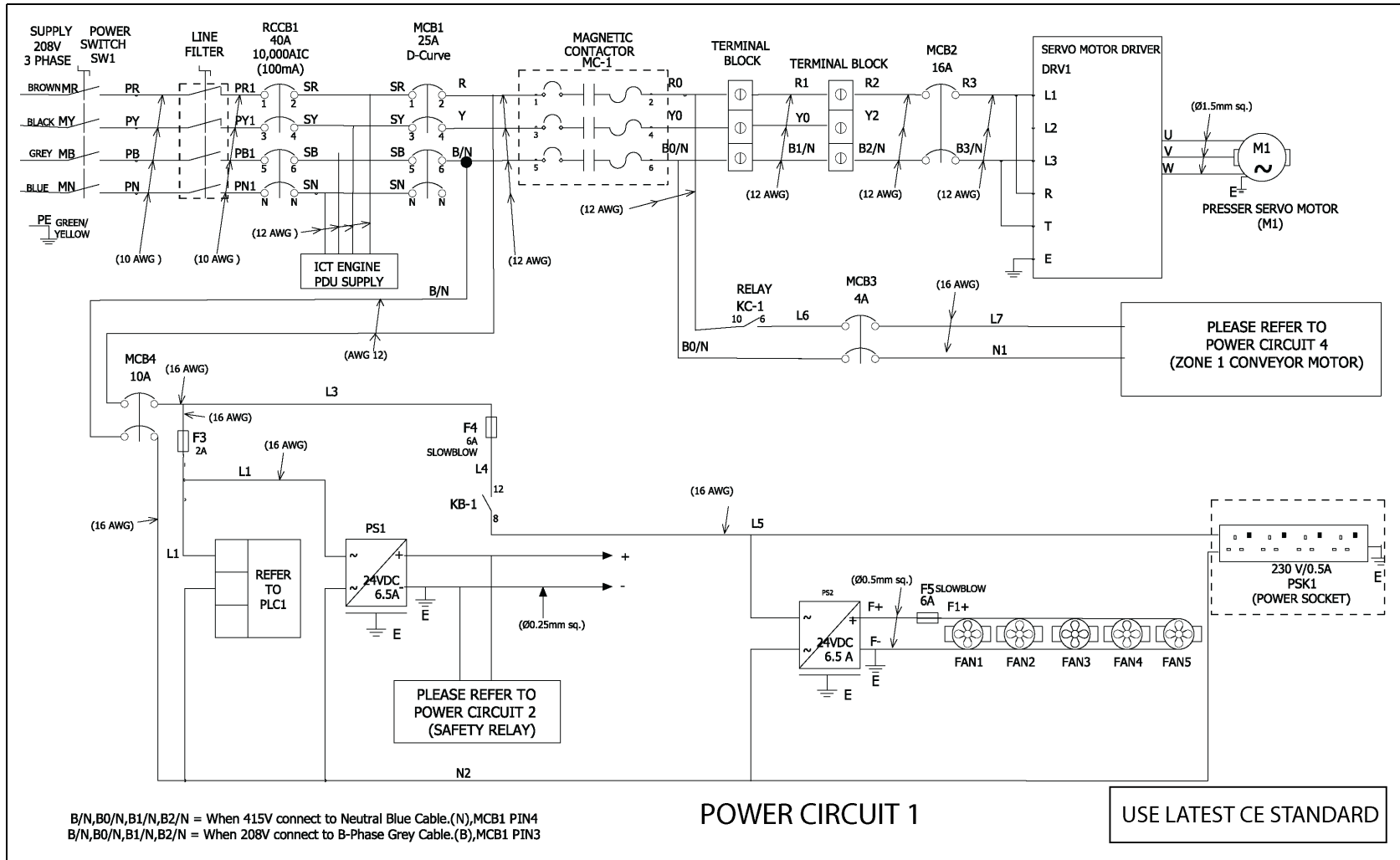

Figure 9-6 Power Circuit 2

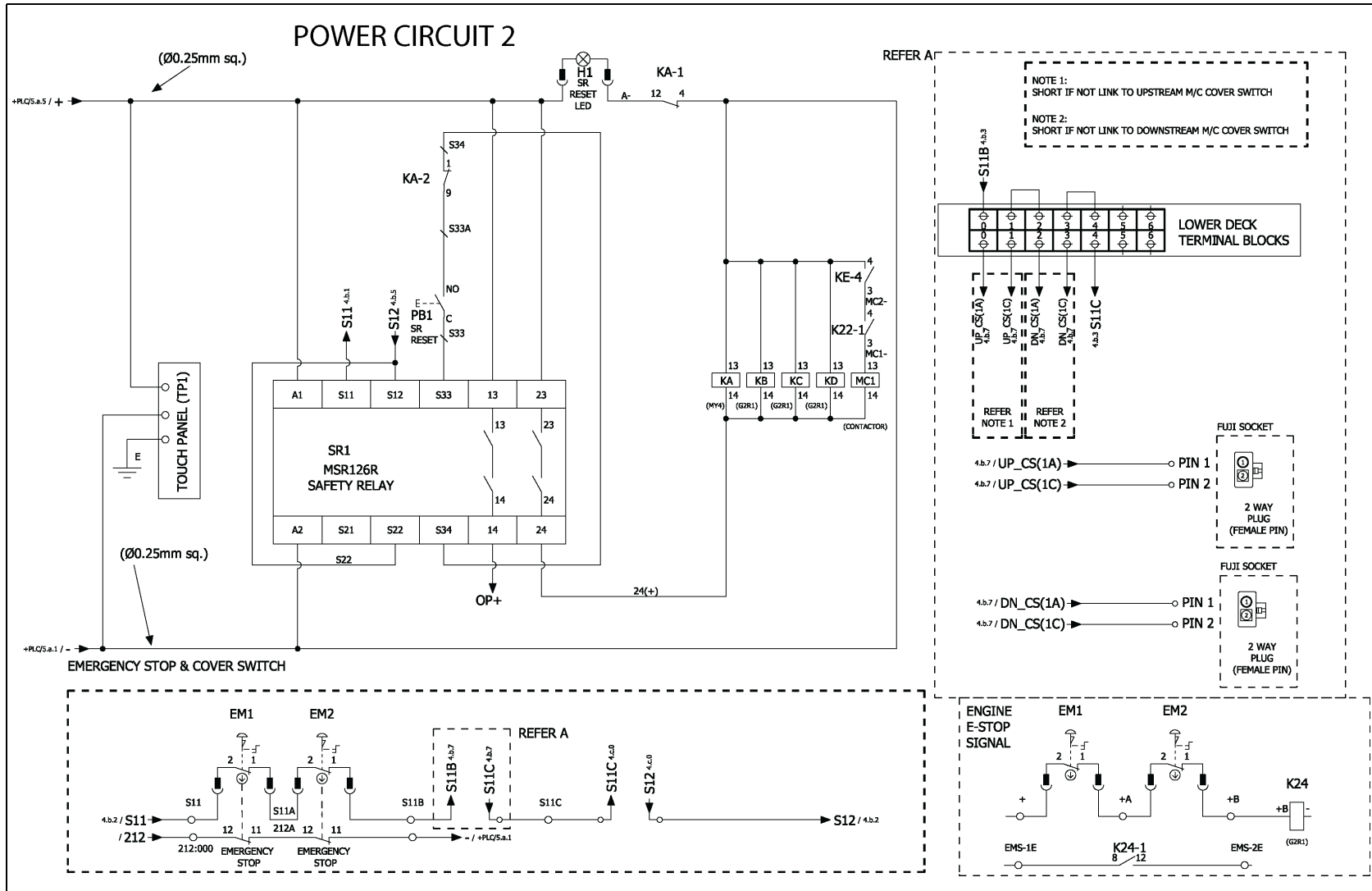

Figure 9-7 Power Circuit 3

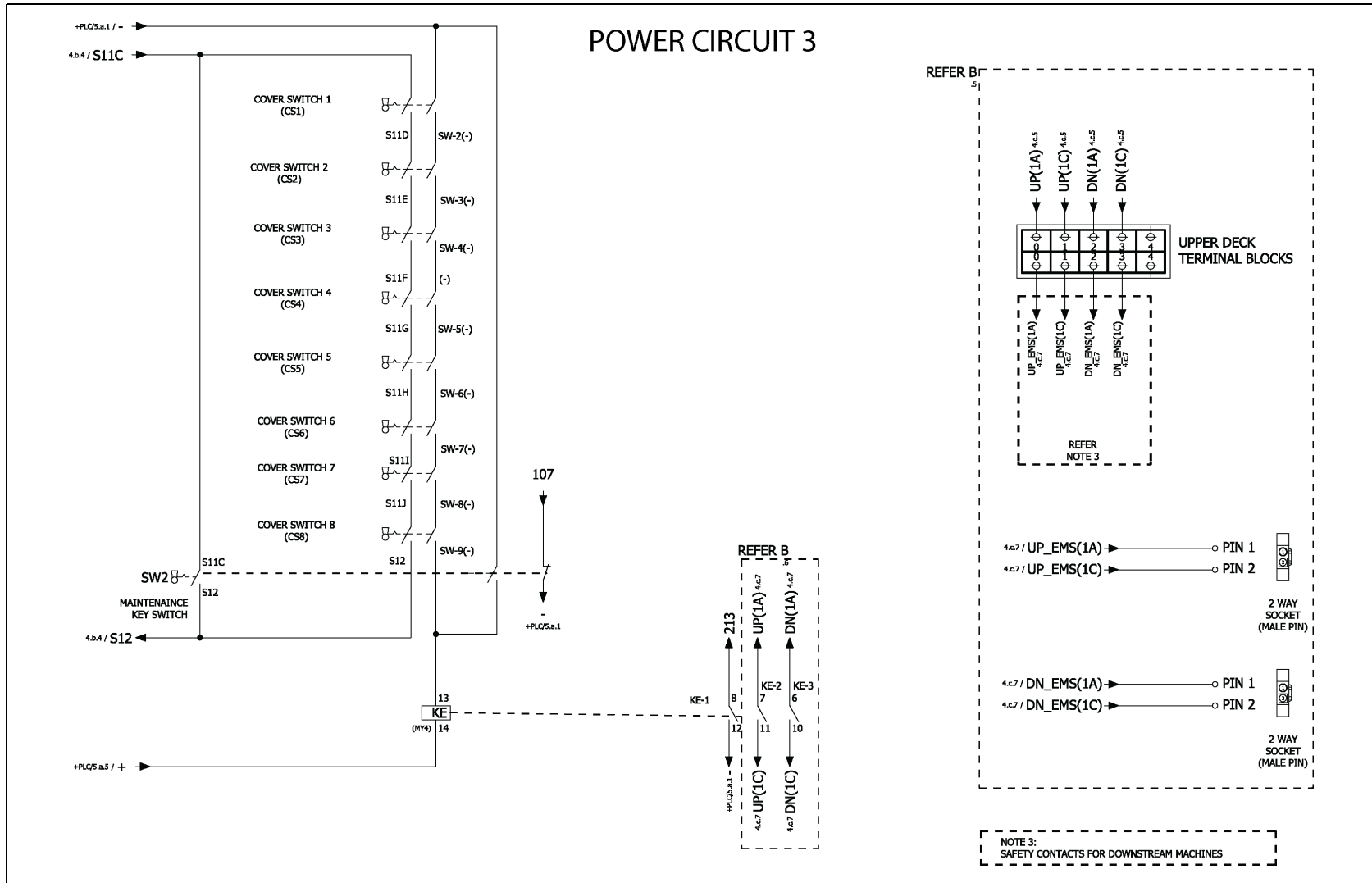

Figure 9-8 Power Circuit 4

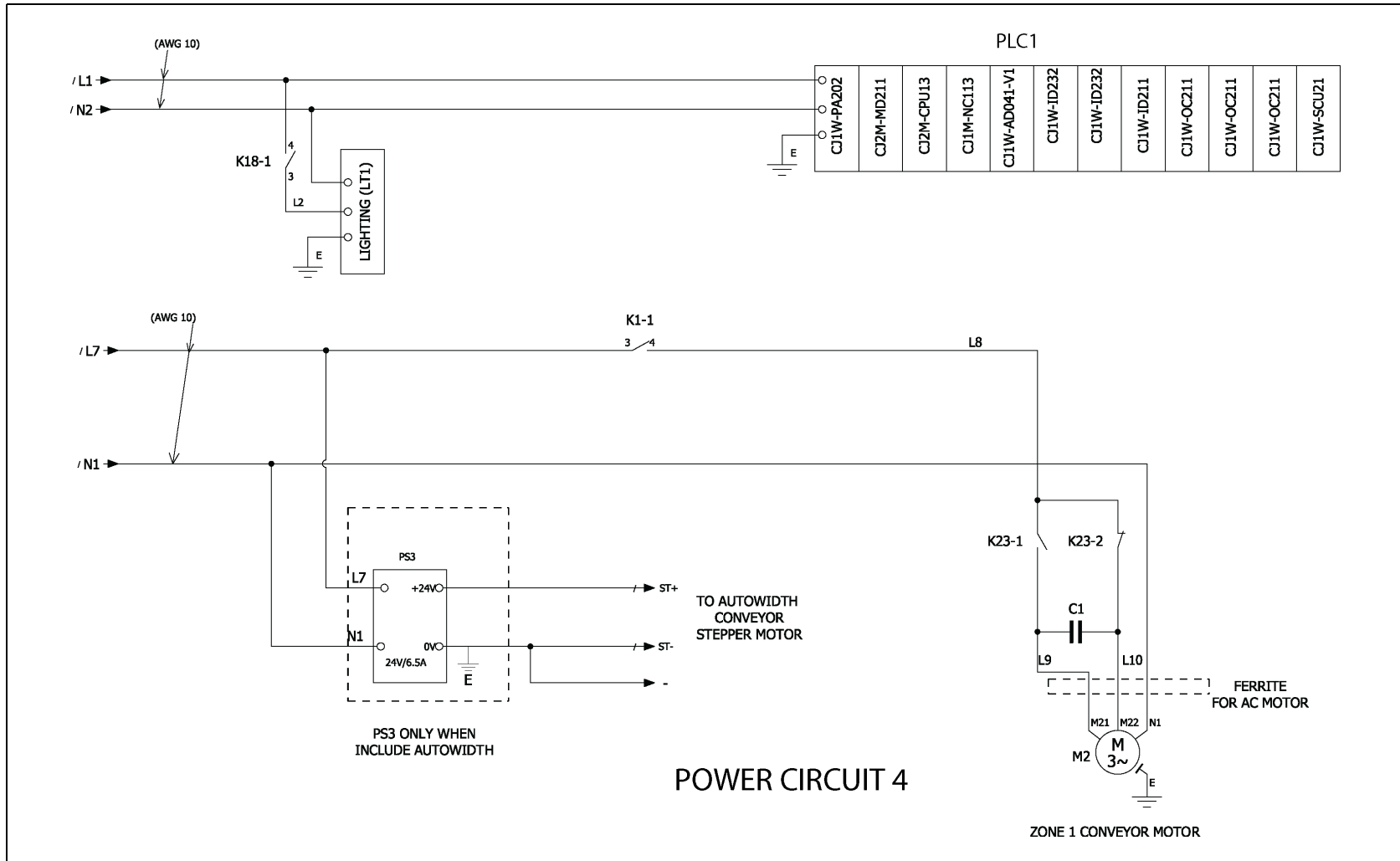

Figure 9-9 Power Circuit 5

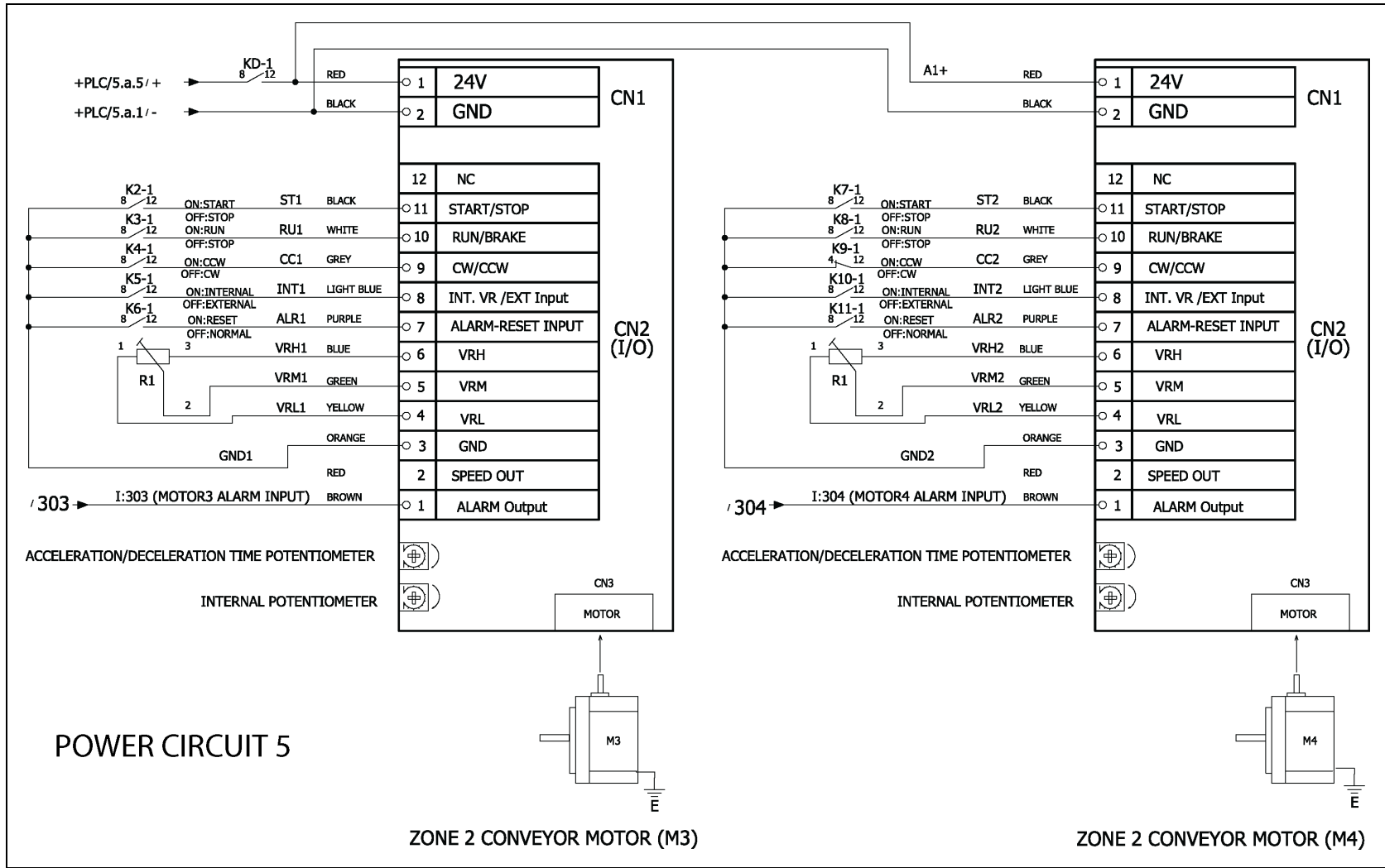

Figure 9-10 Pneumatic 1

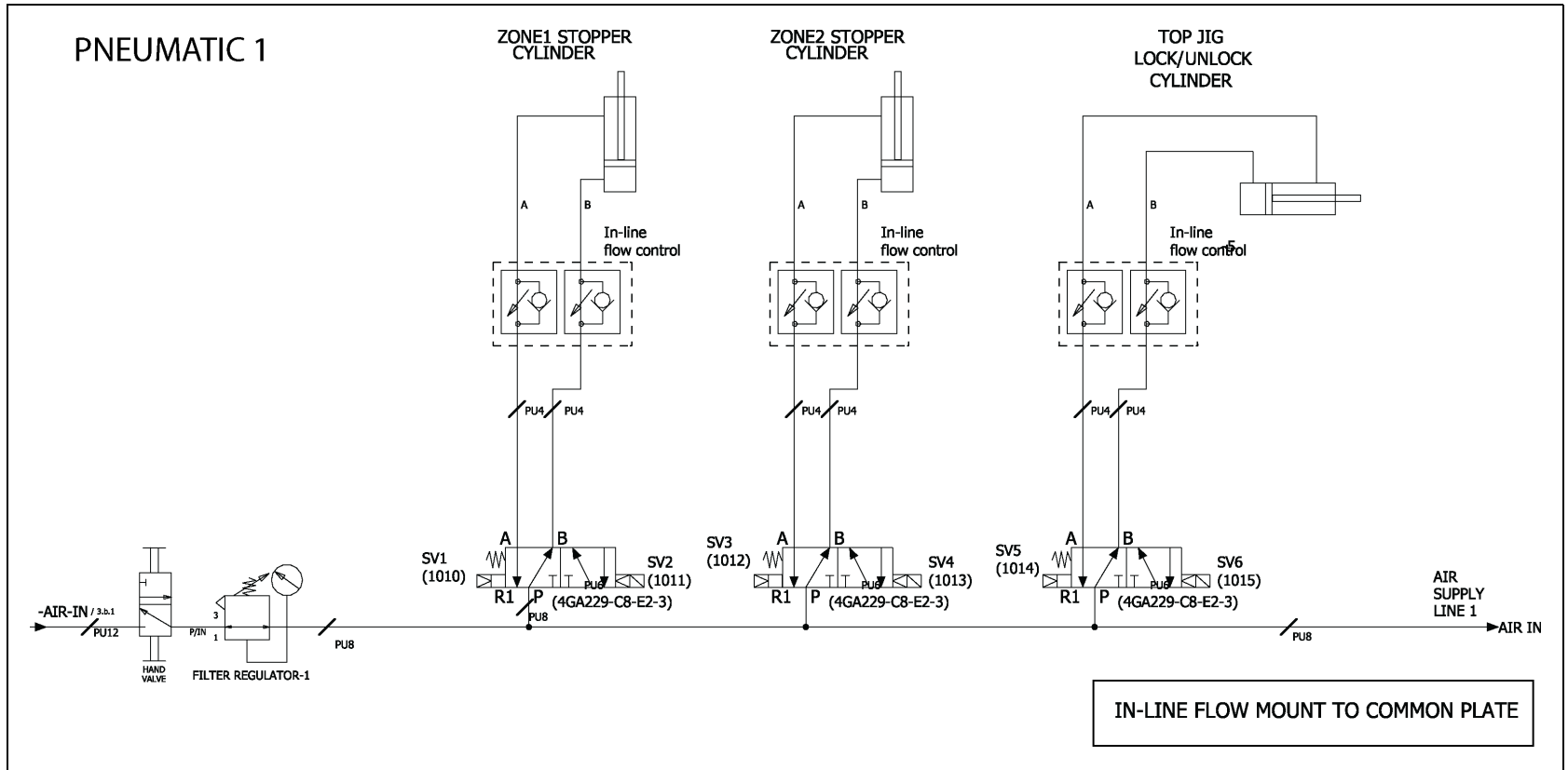
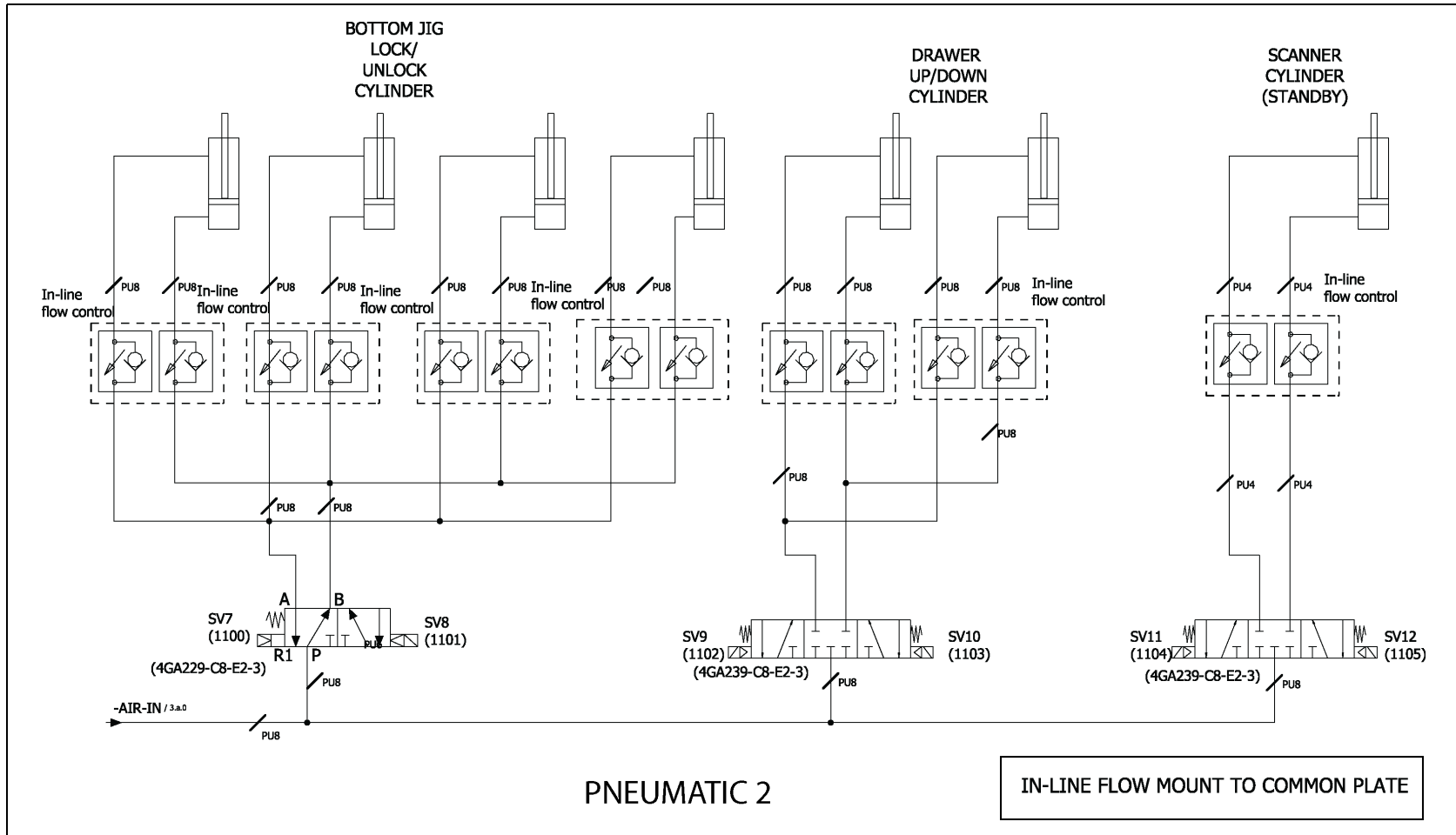

Figure 9-11 Pneumatic 2



PNEUMATIC 2

IN-LINE FLOW MOUNT TO COMMON PLATE

Figure 9-12 Pneumatic 3

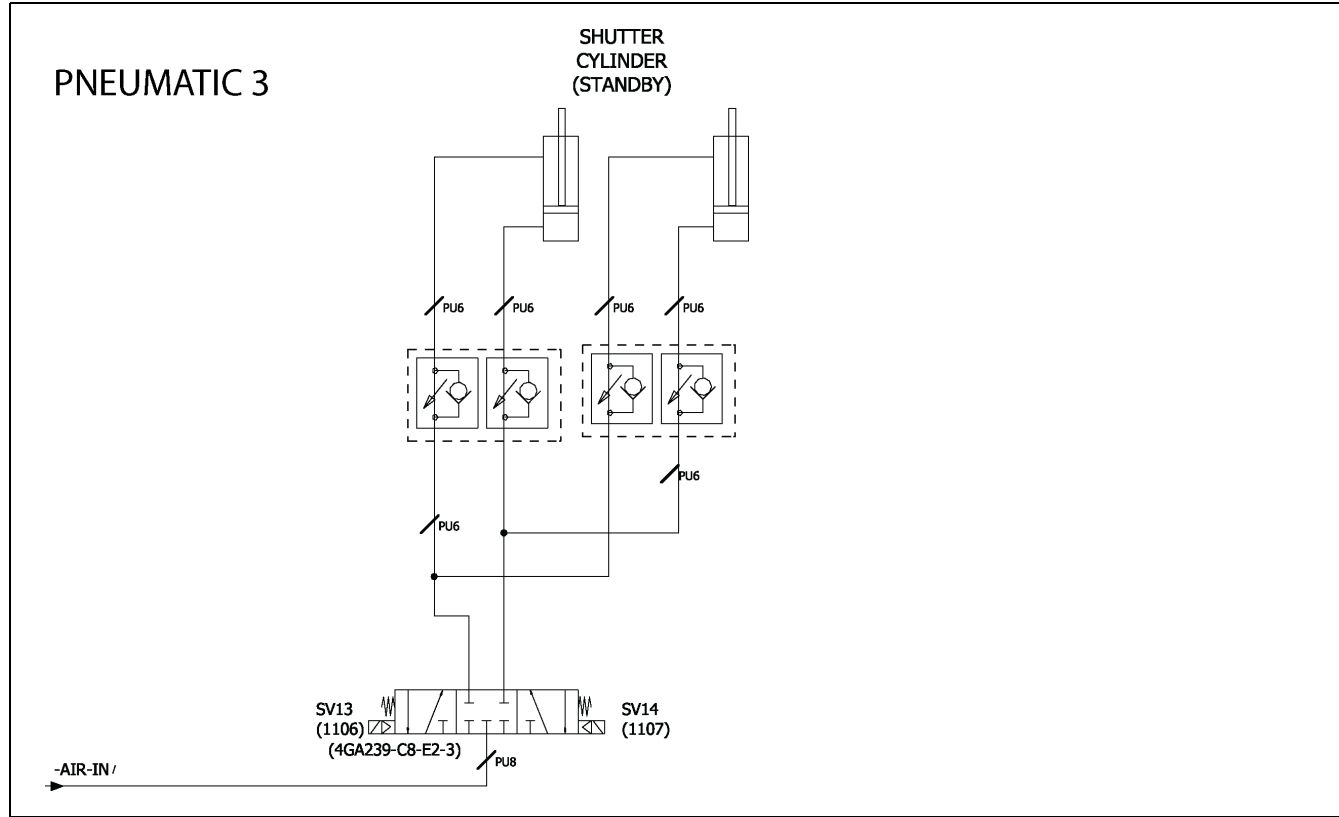

Figure 9-13 PLC Input Unit (Channel 0)

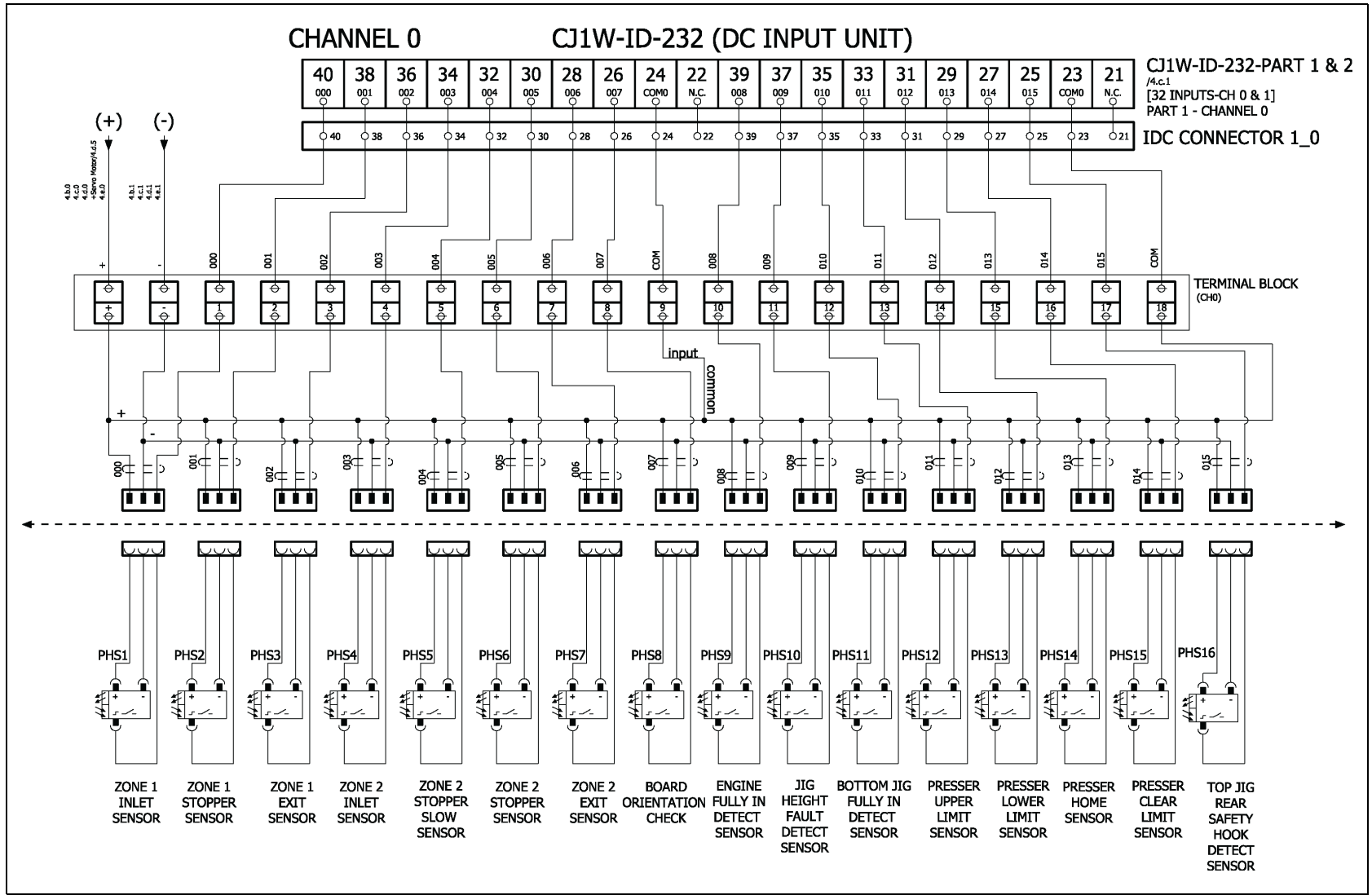

Figure 9-14 PLC Input Unit (Channel 1)

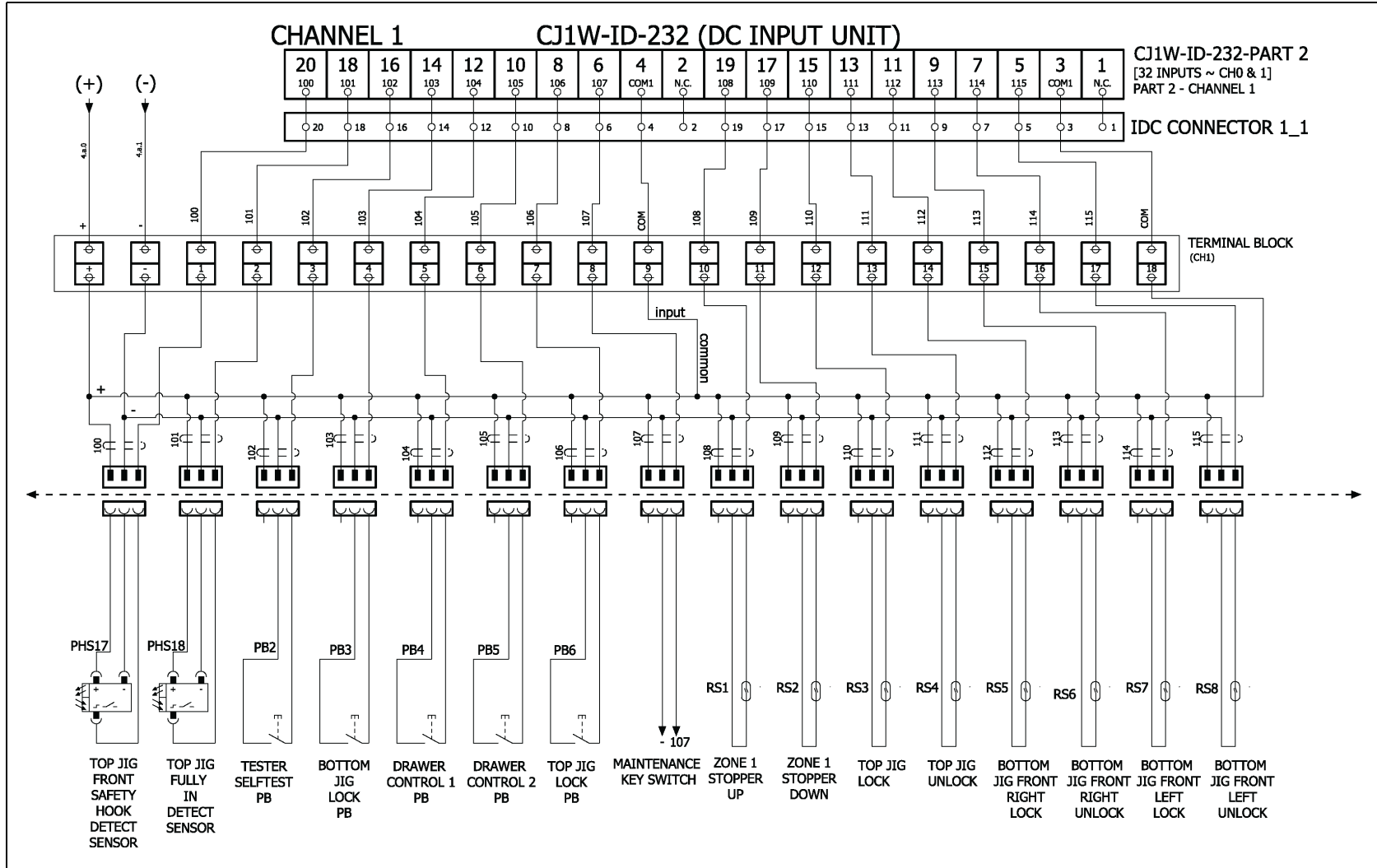

Figure 9-15 PLC Input Unit (Channel 2)

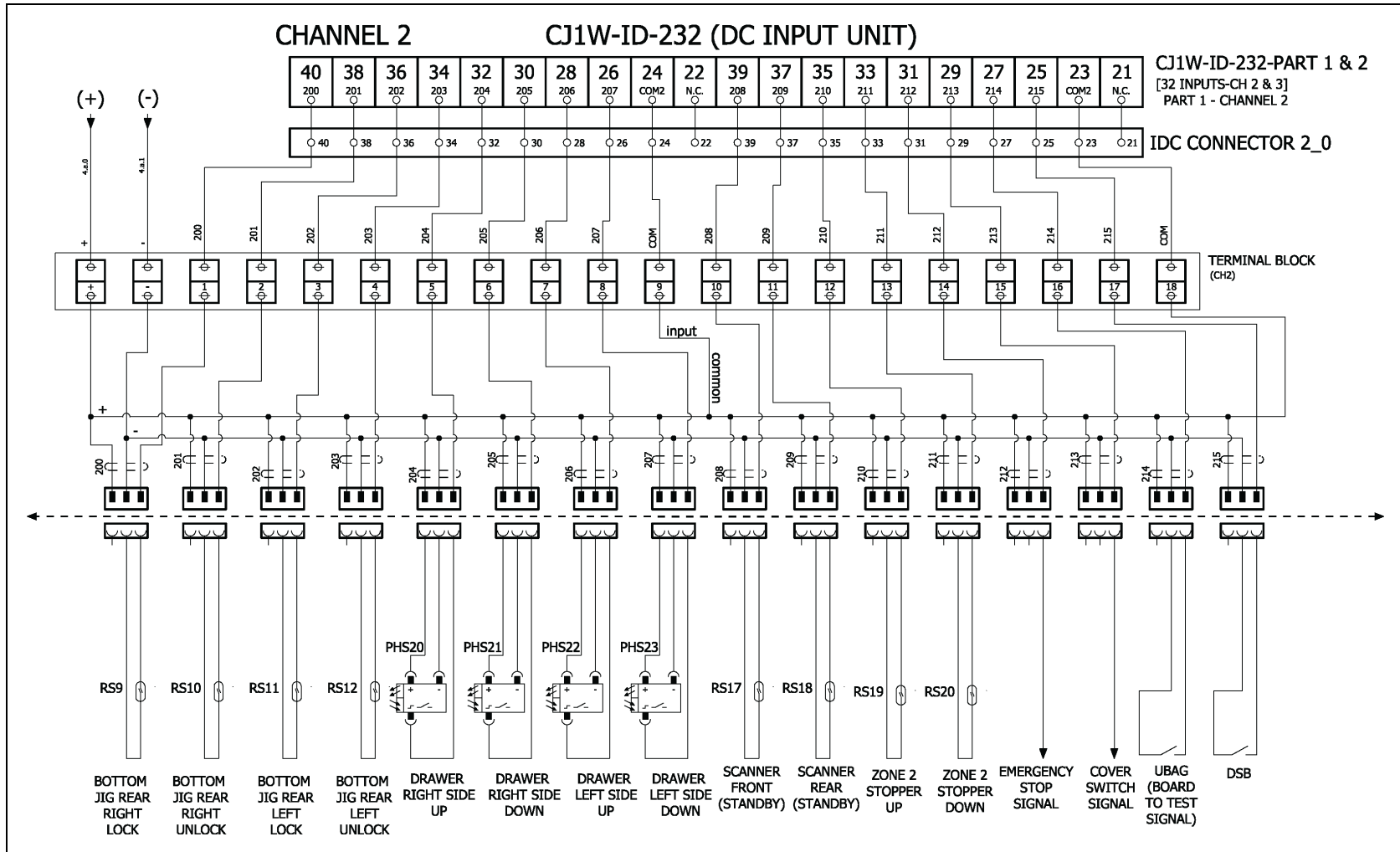

Figure 9-16 PLC Input Unit (Channel 3)

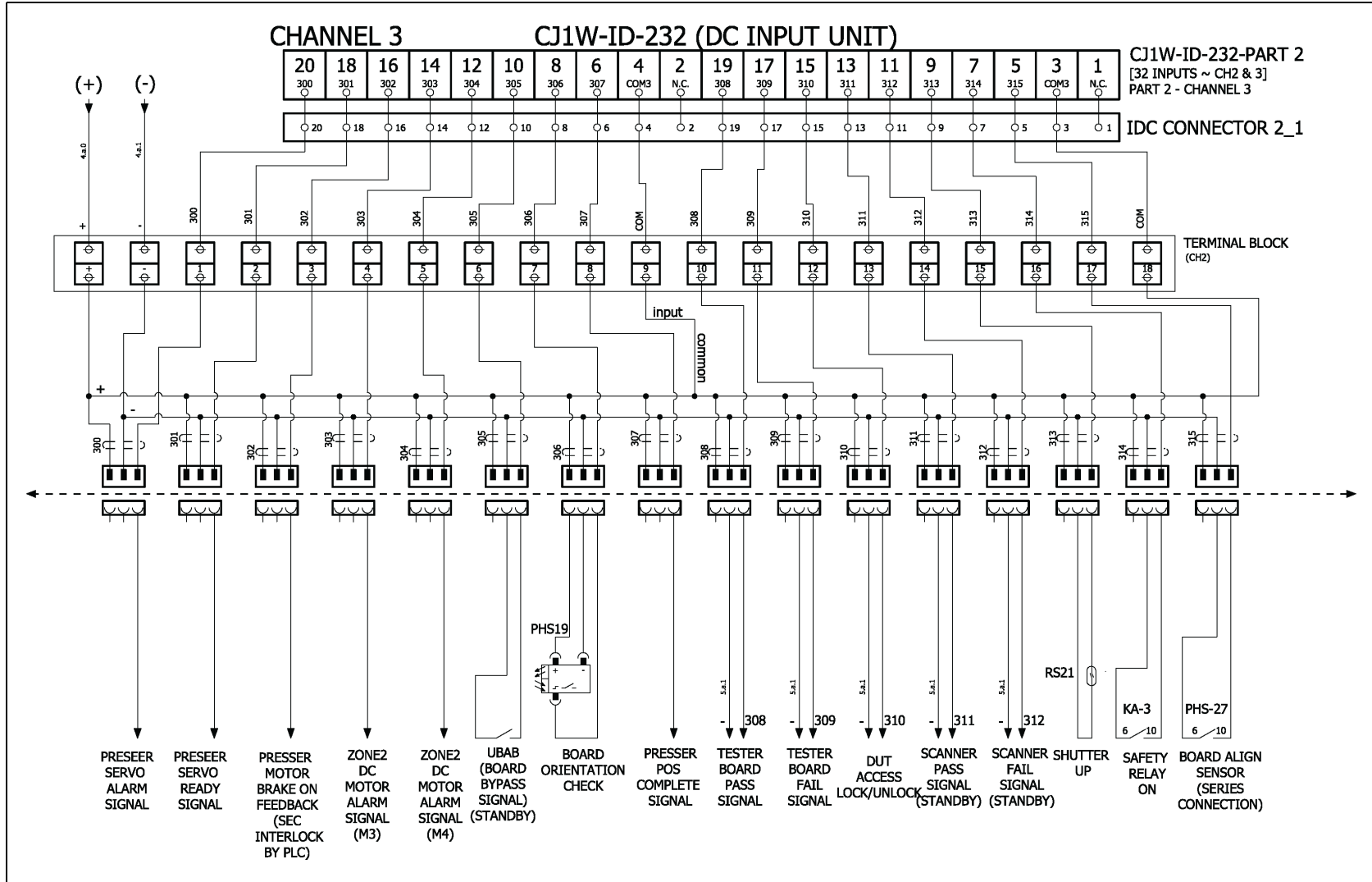

Figure 9-17 PLC Input Unit (Channel 4)

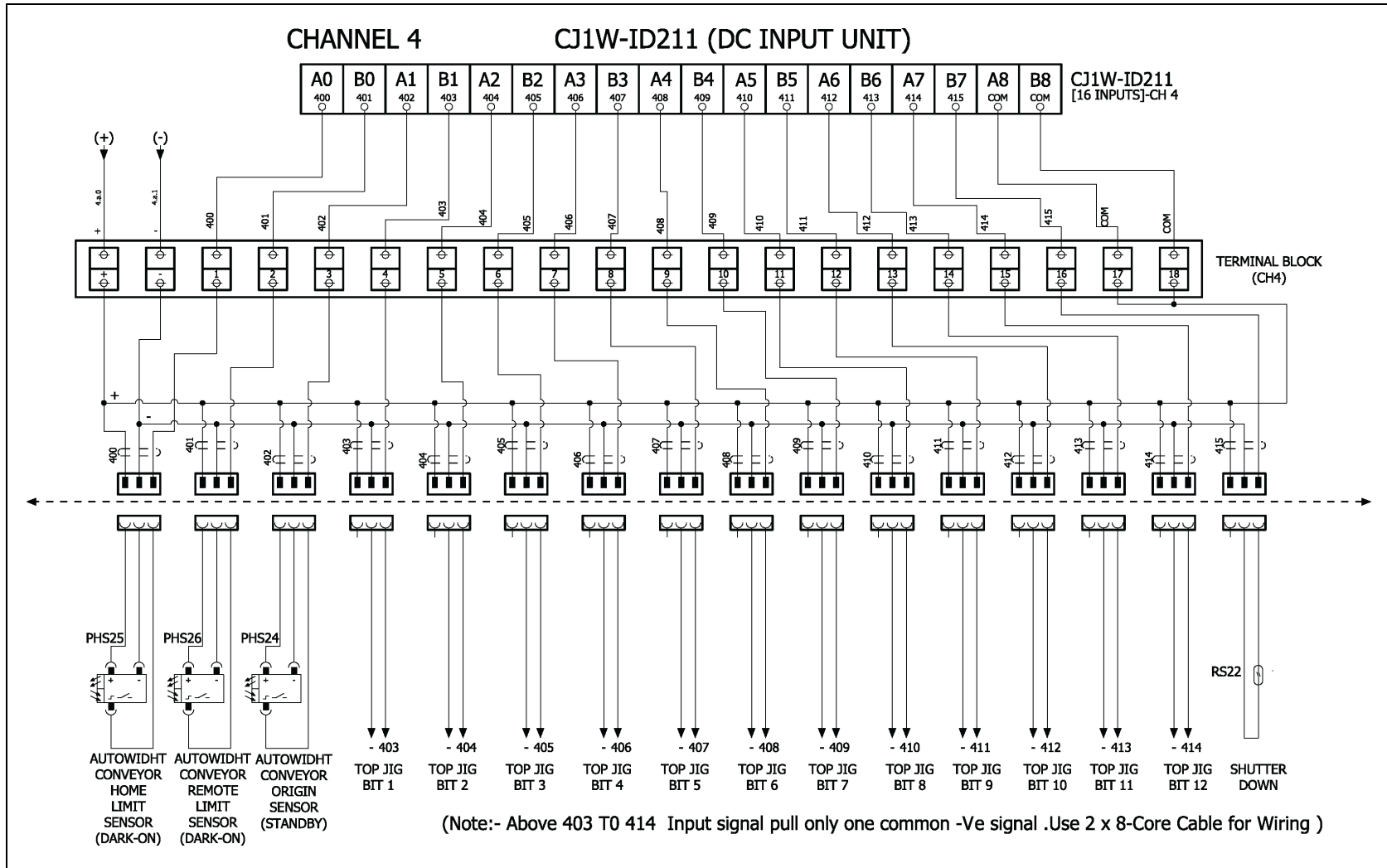

Figure 9-18 PLC Output Unit (Channel 10)

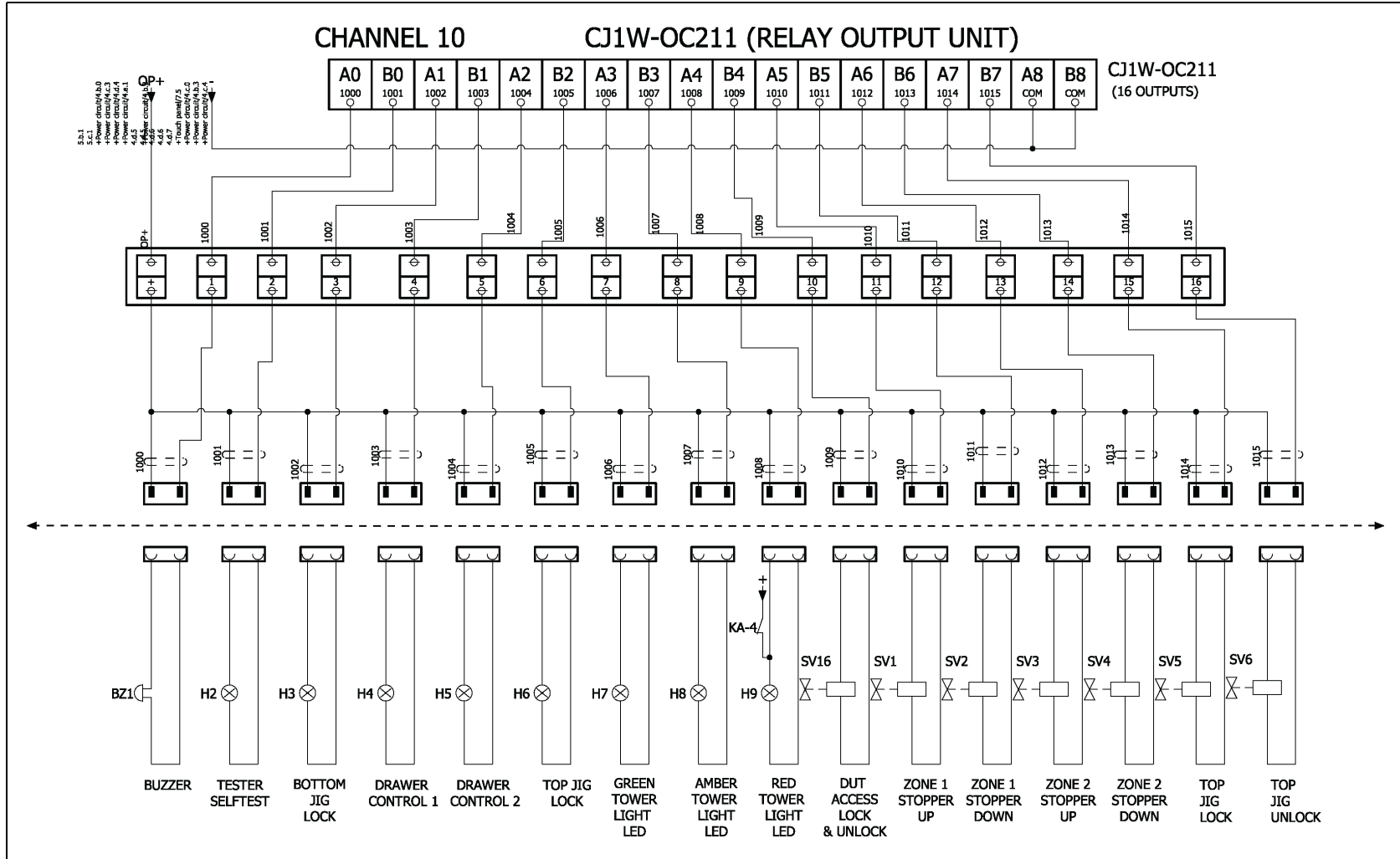

Figure 9-19 PLC Output Unit (Channel 11)

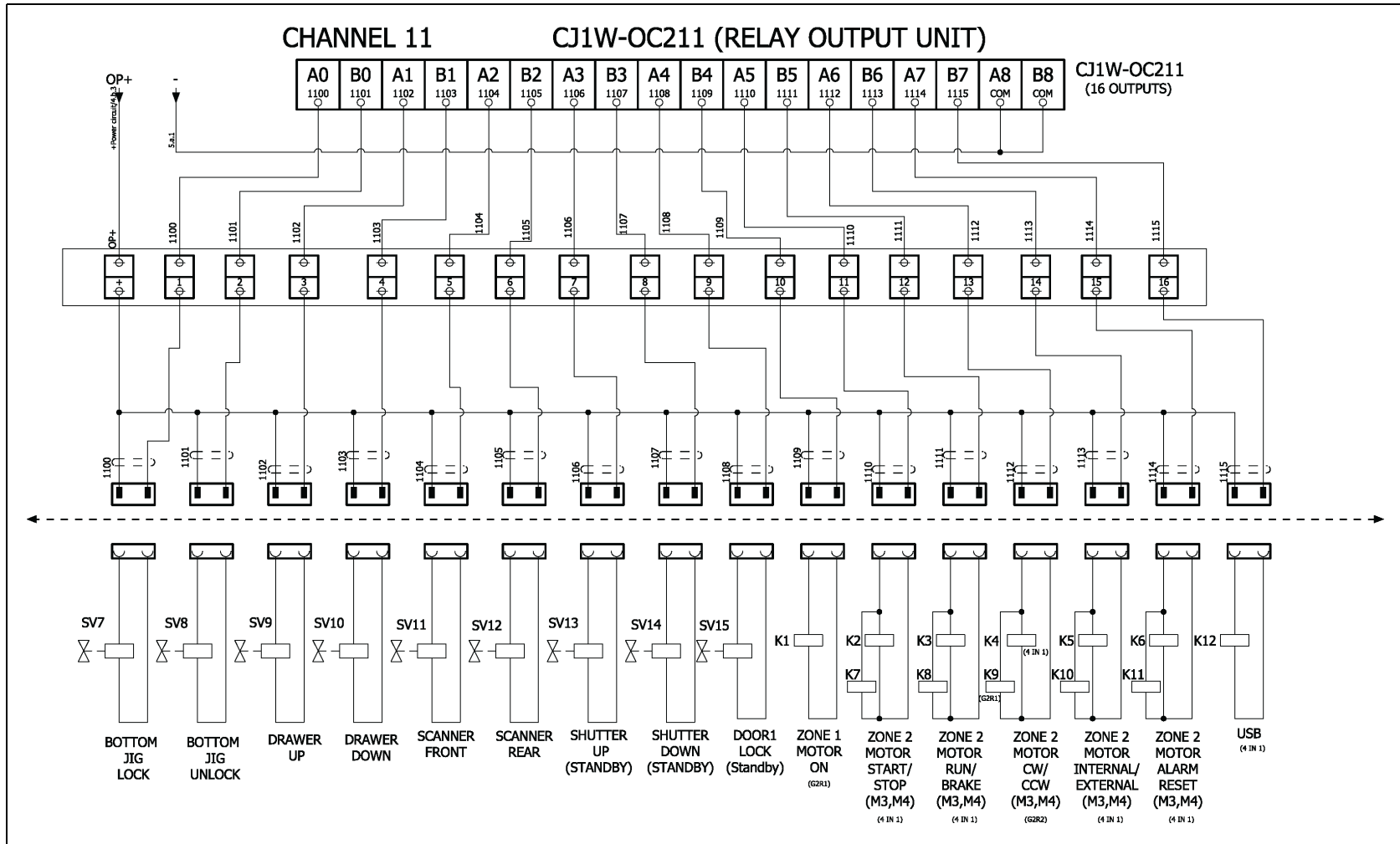

Figure 9-20 PLC Output Unit (Channel 12)

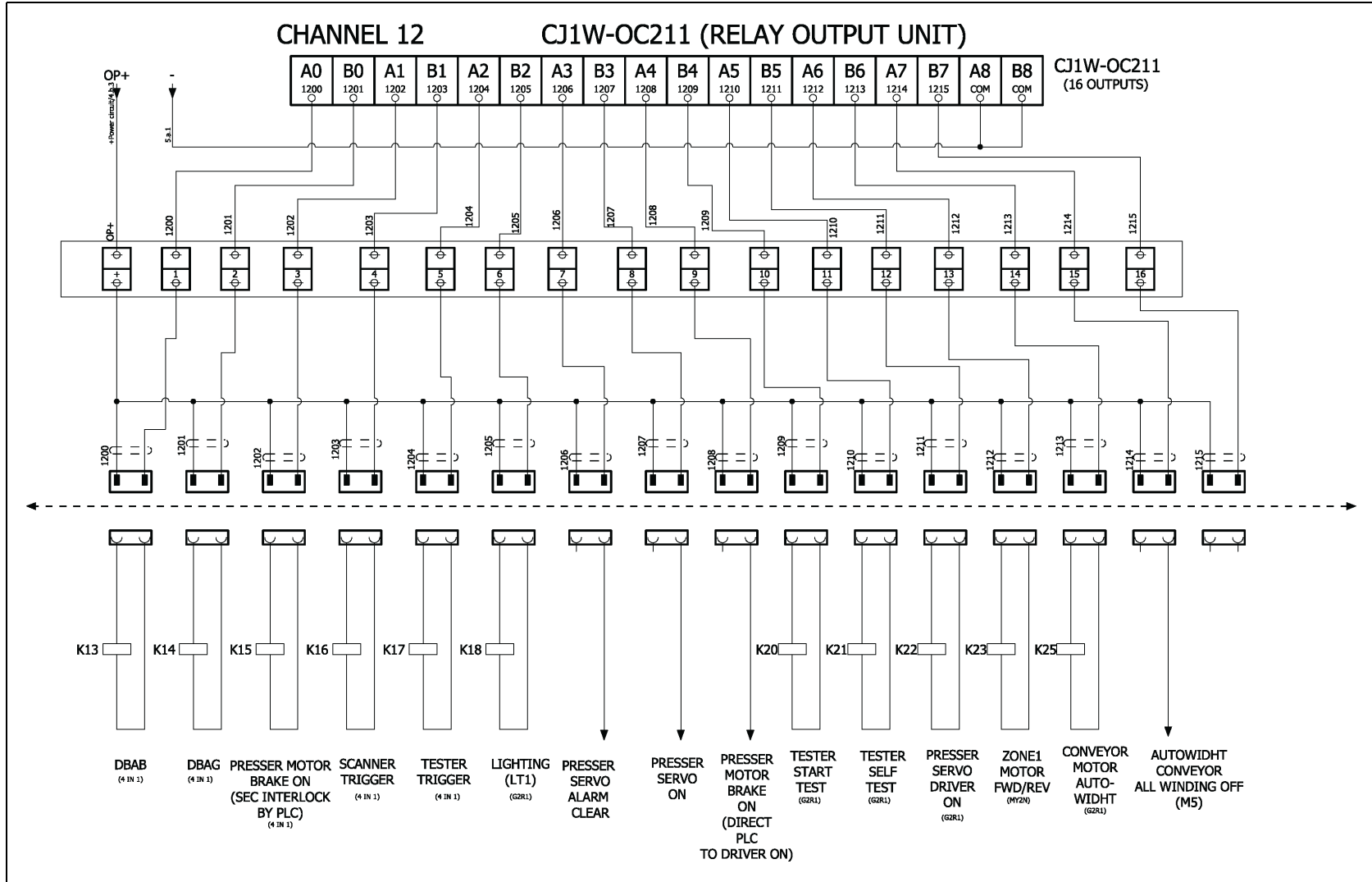

Figure 9-21 Motor and Communication

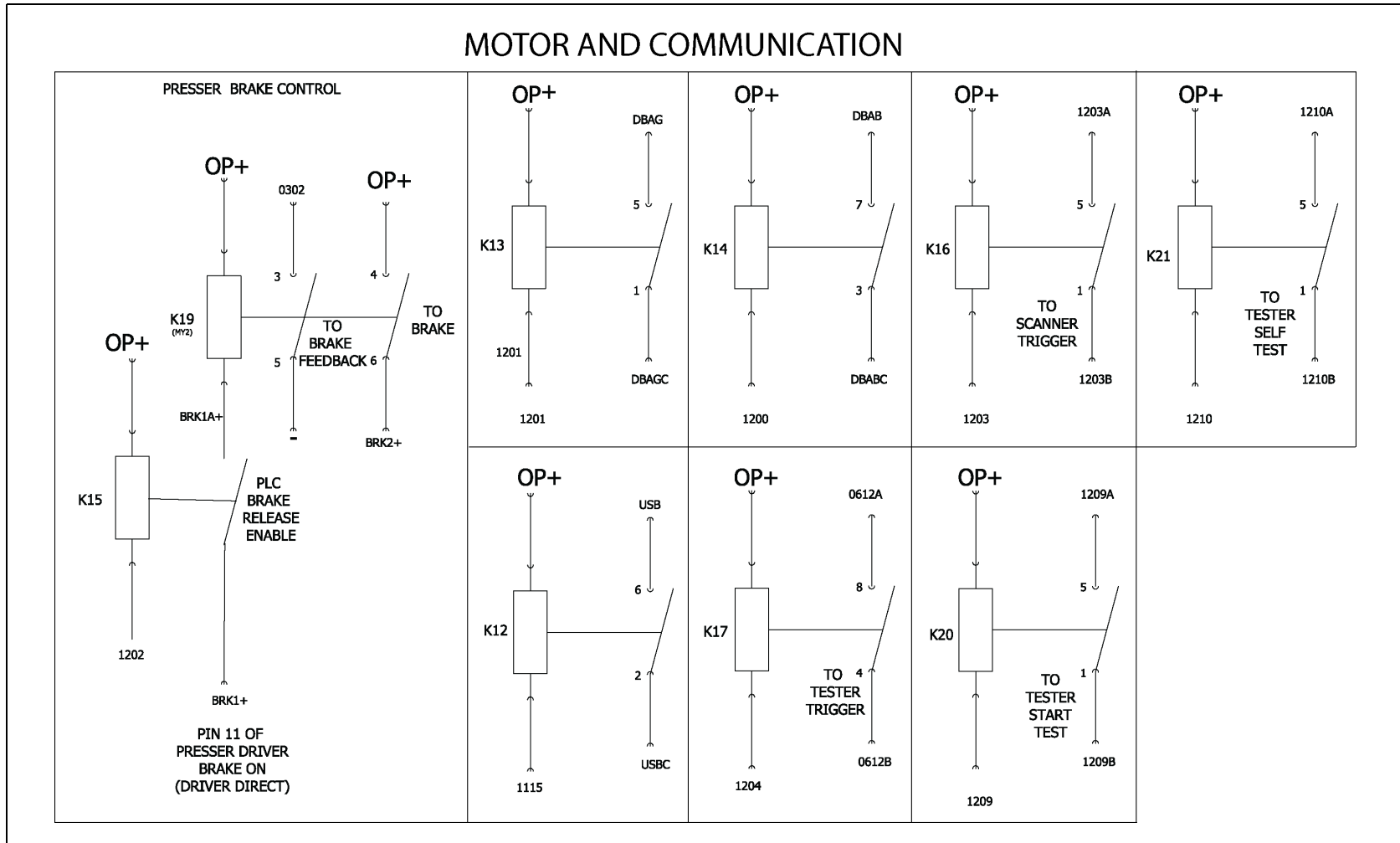

Figure 9-22 PLC to PC Interface

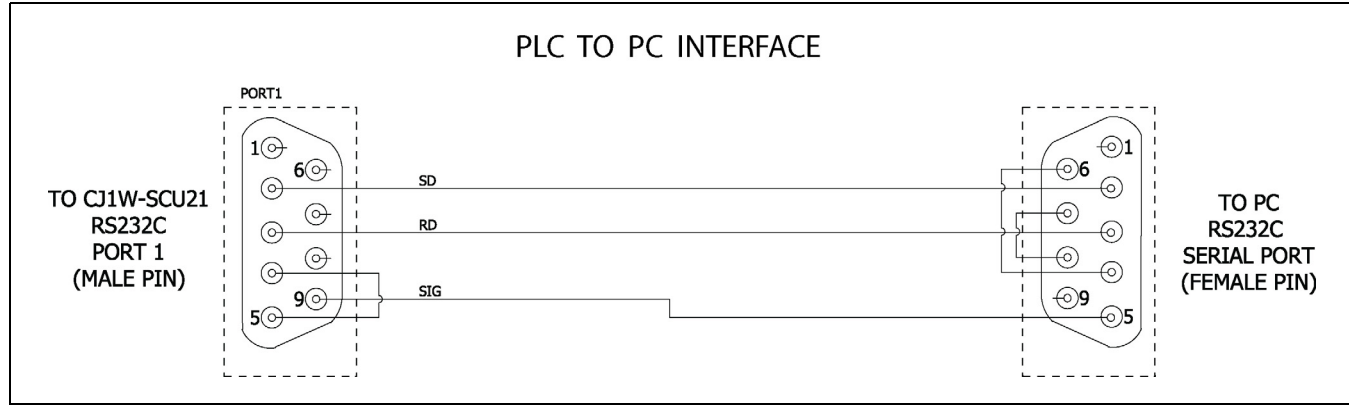

Figure 9-23 Interfacing Cables

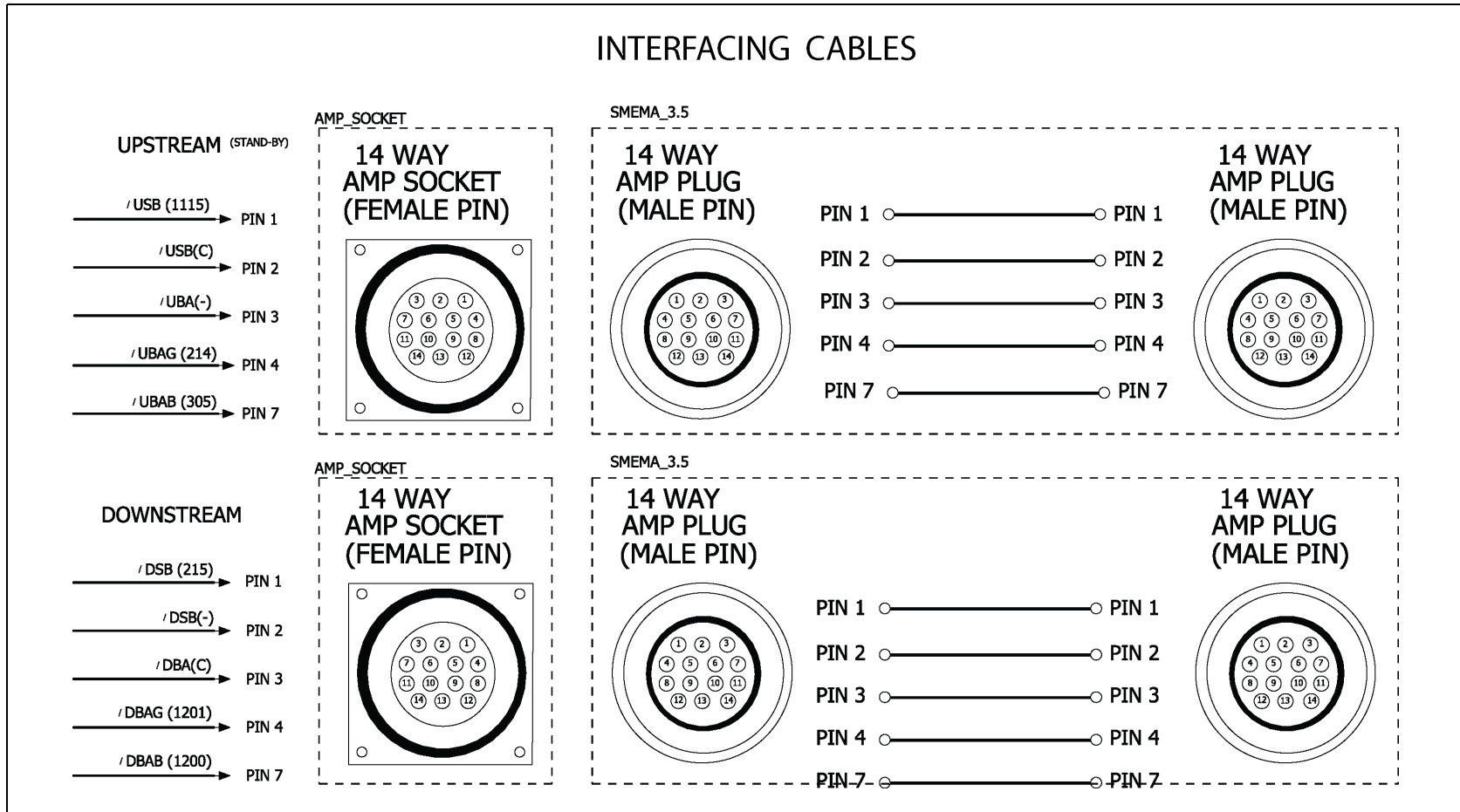

Figure 9-24 SMEMA Communication

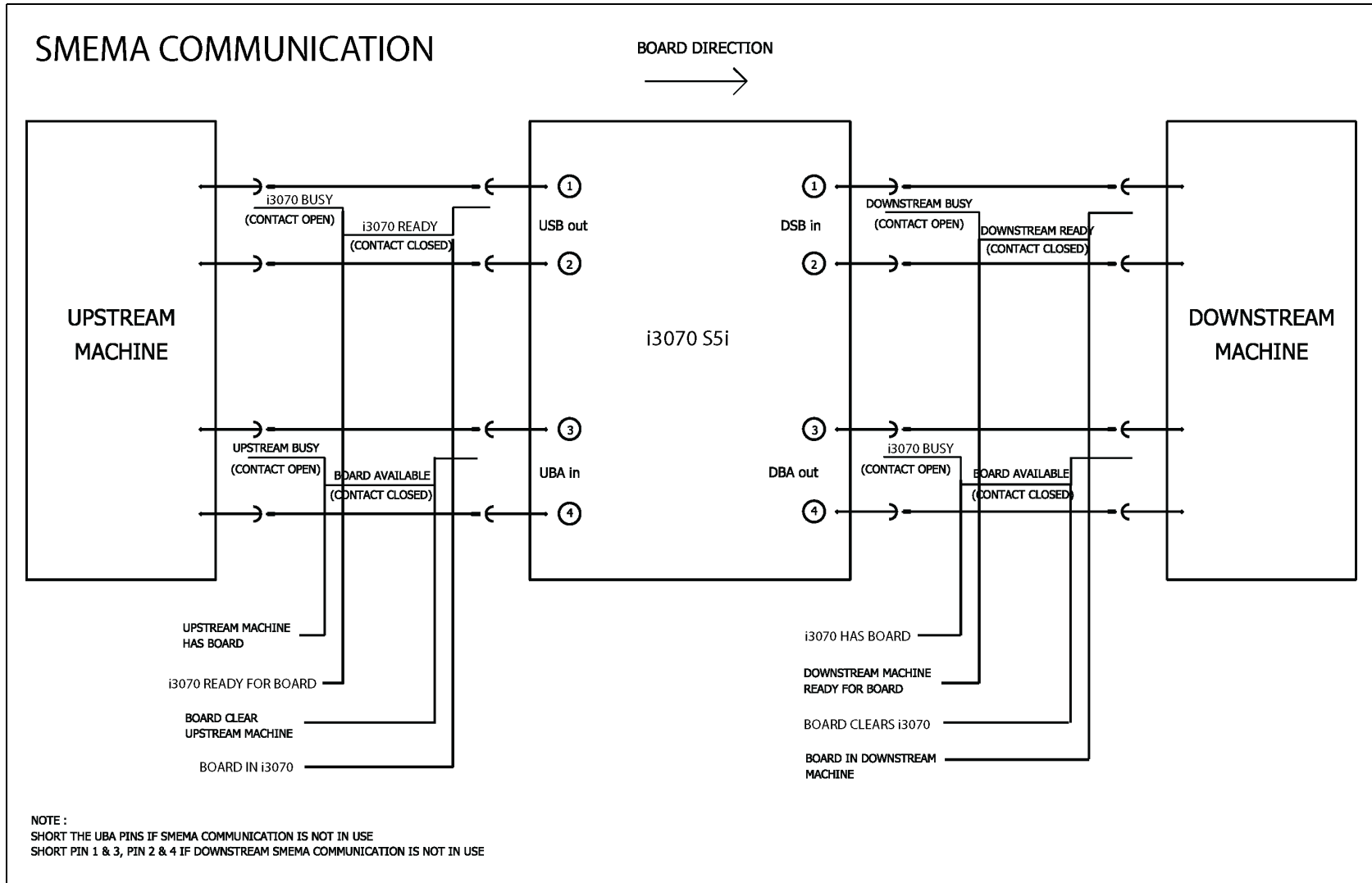

Figure 9-25 Touch Panel

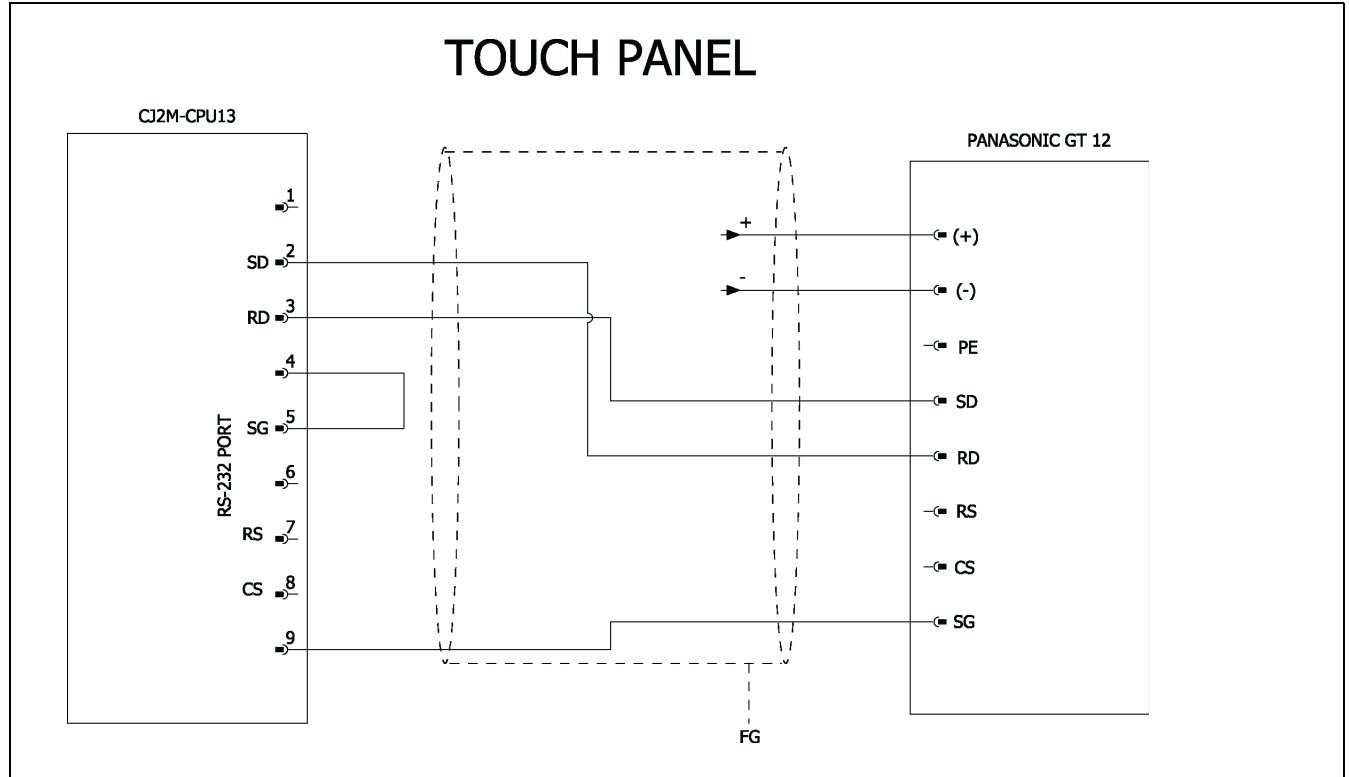

Figure 9-26 Servo Motor

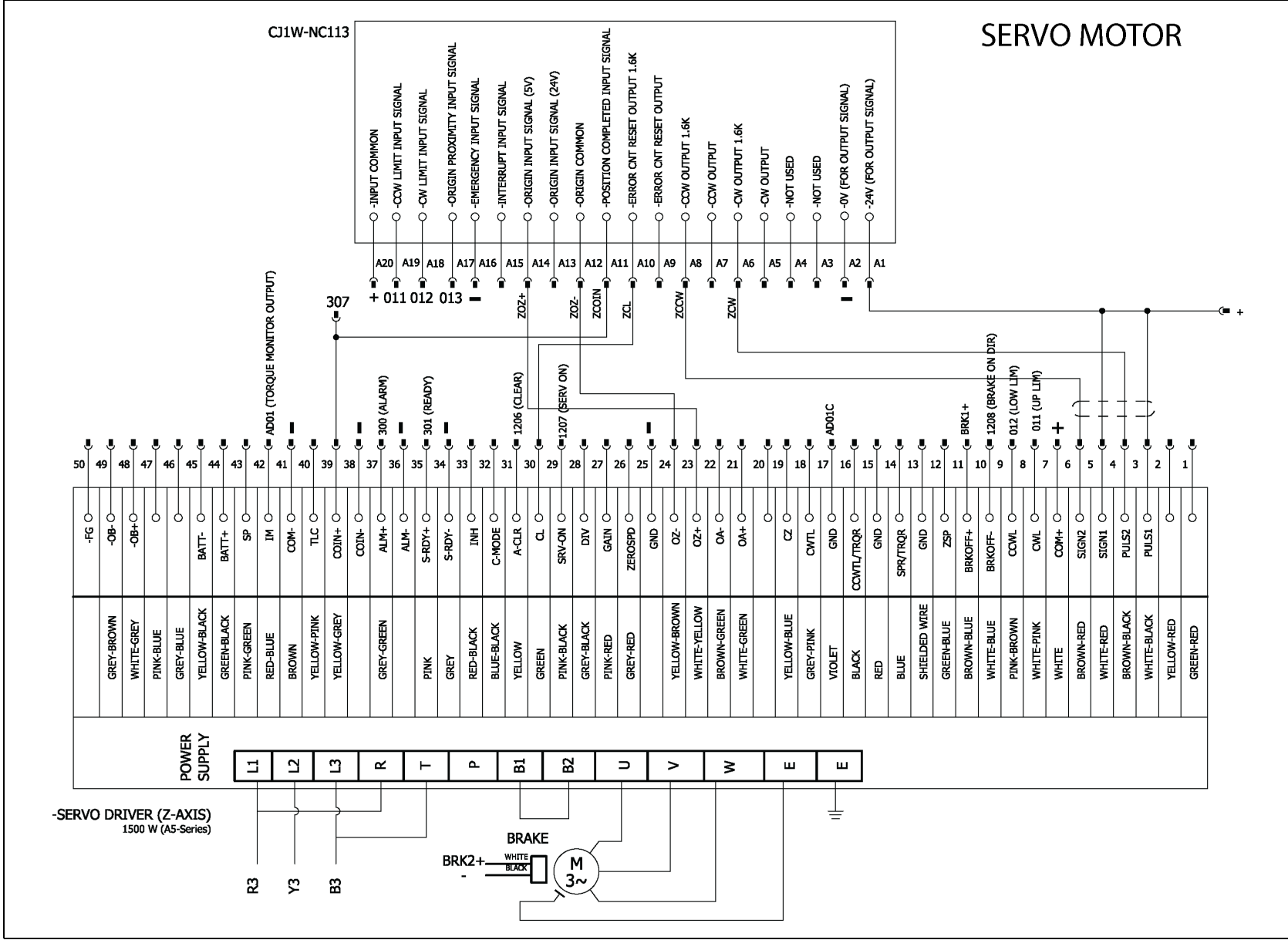

Figure 9-27 Servo Pin Connection

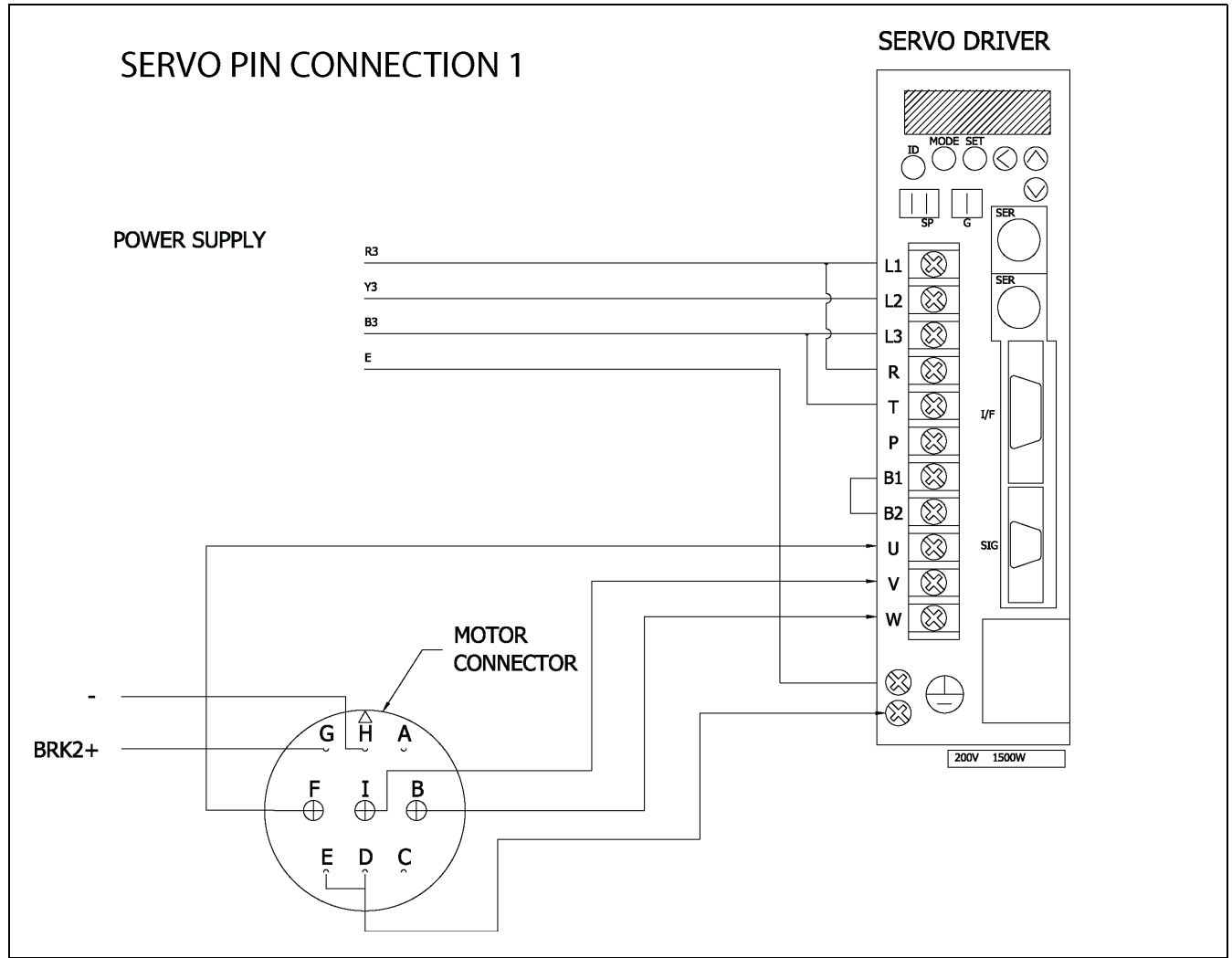

Figure 9-28 Analog Card Interface

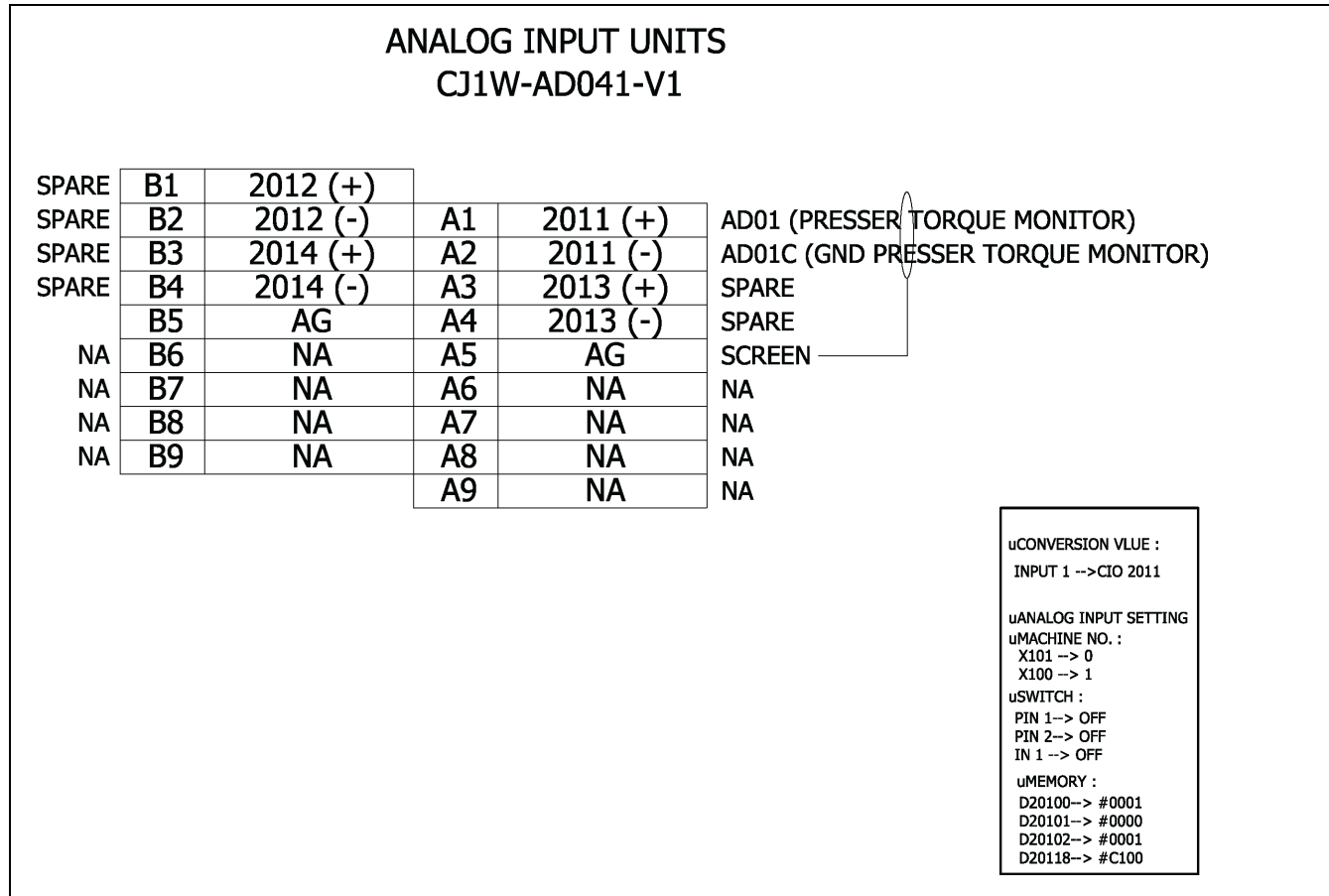

Figure 9-29 Stepper Motor

