

# N2792A and N2793A Differential Probes

User's  
Guide



# Manual Part Number

N2792-97003

September 2014

## Notices

© Keysight Technologies, Inc. 2009 - 2014  
Keysight Technologies, Inc



This product complies with the WEEE Directive (2002/96/EC) marking requirements. The affixed label indicates that you must not discard this electrical/electronic product in domestic household

waste. Product Category: With reference to the equipment types in the WEEE Directive Annex I, this product is classed as a "Monitoring and Control instrumentation" product. Do not dispose in domestic household. To return unwanted products, contact your local Keysight office, or refer to [www.keysight.com](http://www.keysight.com) for more information.



This symbol indicates the Environmental Protection Use Period (EPUP) for the product's toxic substances for the China RoHS requirements.

## Restricted Rights Legend

If software is for use in the performance of a U.S. Government prime contract or subcontract, Software is delivered and licensed as "Commercial computer software" as defined in DFAR 252.227-7014 (June 1995), or as a "commercial item" as defined in FAR 2.101(a) or as "Restricted computer software" as defined in FAR 52.227-19 (June 1987) or any equivalent agency regulation or contract clause. Use, duplication or disclosure of Software is subject to Keysight Technologies' standard commercial license terms, and non-DOD Departments and Agencies of the U.S. Government will receive no greater than Restricted Rights as defined in FAR 52.227-19(c)(1-2) (June 1987). U.S. Government users will receive no greater than Limited Rights as defined in FAR 52.227-14 (June 1987) or DFAR 252.227-7015 (b)(2) (November 1995), as applicable in any technical data.

## Warranty

The material contained in this document is provided "as is," and is subject to being changed, without

notice, in future editions. Further, to the maximum extent permitted by applicable law, Keysight disclaims all warranties, either express or implied, with regard to this manual and any information contained herein, including but not limited to the implied warranties of merchantability and fitness for a particular purpose. Keysight shall not be liable for errors or for incidental or consequential damages in connection with the furnishing, use, or performance of this document or of any information contained herein. Should Keysight and the user have a separate written agreement with warranty terms covering the material in this document that conflict with these terms, the warranty terms in the separate agreement shall control.

## Safety Notices

**CAUTION.** A **CAUTION** notice denotes a hazard. It calls attention to an operating procedure, practice, or the like that, if not correctly performed or adhered to, could result in damage to the product or loss of important data. Do not proceed beyond a **CAUTION** notice until the indicated conditions are fully understood and met.

**WARNING.** A **WARNING** notice denotes a hazard. It calls attention to an operating procedure, practice, or the like that, if not correctly performed or adhered to, could result in personal injury or death. Do not proceed beyond a **WARNING** notice until the indicated conditions are fully understood and met.

# Contents

Introduction	4
Accessories	6
Using the N2792A Probe	9
Using the N2793A Probe	11
Safety Information	15
Specifications and Characteristics	16
Performance Plots (N2792A Probe)	19
Performance Plots (N2793A Probe)	23
N2792A Performance Verification Procedures	27
N2793A Performance Verification Procedures	31
Offset Zero Calibration Procedure	35

# Introduction

The N2792A 200 MHz and N2793A 800 MHz differential probes provide the superior high-speed differential signal probing required by today's high-speed power measurements, automotive bus measurements, and high-speed digital system designs. The N2792A and N2793A probes offer a 10:1 attenuation ratio, allowing them to be used for a broad range of applications. These differential probes have an input resistance of 1 M $\Omega$  (N2792A) and 200 k $\Omega$  (N2793A) and both feature low input capacitance to minimize circuit loading (7 pF for N2792A and 2 pF for N2793A). The N2792A and N2793A probes are compatible with any oscilloscope equipped with 50 $\Omega$  BNC inputs. They can be powered by any USB port on your oscilloscope or computer, or by an internal battery (one 9V battery included with each probe).

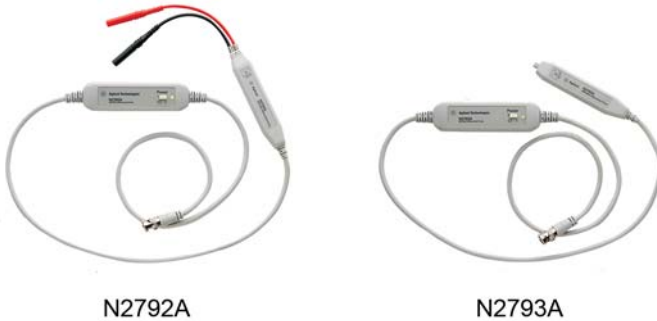

Figure 1 Probes (Accessories Not Shown)

## Oscilloscope Compatibility

To be compatible with the N2792A and N2793A probes, the oscilloscope must have a 50 $\Omega$  input and be ground referenced.

## Handling the Probe

Handle the probe with care and refer to the safety notices in this manual. Note that the probe cable is a sensitive part of the probe and, therefore, you should be careful not to damage it through excessive bending or pulling. You should also avoid any mechanical shocks to this product in order to guarantee accurate performance and protection.

## Cleaning the Probe

Disconnect the probe from the oscilloscope and clean the probe with a soft cloth dampened with a mild soap and water solution. Make sure that the probe is completely dry before reconnecting it to an oscilloscope. Avoid using abrasive cleaners and chemicals containing benzene or similar solvents.

## Inspecting the Probe

- Inspect the shipping container for damage.  
Keep the damaged shipping container or cushioning material until the contents of the shipment have been checked for completeness and the probe has been checked mechanically and electrically.
- Check the accessories.
- If the contents are incomplete or damaged, notify your Keysight Technologies Sales Office.
- Inspect the instrument.
- If there is mechanical damage or defect, or if the probe does not operate properly or pass calibration tests, notify the Sales Office.

If the shipping container is damaged, or the cushioning materials show signs of stress, notify the carrier as well as the Sales Office. Keep the shipping materials for the carrier's inspection. The sales office will arrange for repair or replacement at Keysight Technologies' option without waiting for claim settlement.

# Accessories

## N2792A

**Table 1** lists the accessories included with the N2792A probes. Replacements can be ordered with the N2792-68700 replacement kit. The quantity of each accessory in the kit is the same as listed in the table and originally provided with the probe. The battery is not included in the kit.



Figure 2 N2792A Supplied Accessories

Table 1 N2792A Accessories

Accessory	Qty Supplied
Hook Clip (red)	1
Hook Clip (black)	1
Alligator Clip (red)	1
Alligator Clip (black)	1
USB Power Cord (2m)	1
9V Battery	1
Trimmer tool	1

# N2793A

**Table 2** lists the accessories included with the N2793A probes. Replacements can be ordered with the N2793-68700 replacement kit. The quantity of each accessory in the kit is the same as listed in the table and originally provided with the probe. The battery is not included in the kit.



Figure 3 N2793A Supplied Accessories

Table 2 N2793A Accessories

Accessory	Qty Supplied
Pincer Clip (red)	1
Pincer Clip (black)	1
Micro IC Clip (red)	1
Micro IC Clip (black)	1
Extension Lead, 0.8 mm J-P, 5 cm (red)	1
Extension Lead, 0.8 mm J-P, 5 cm (black)	1
Extension Lead, 0.8 mm J-P, 10 cm (red)	1
Extension Lead, 0.8 mm J-P, 10 cm (black)	1
Dual Signal Pin, 12.8 mm	2
Dual Signal Pin, 16.8 mm	2
Single Signal Pin, 0.8 mm	6
Variable Pitch Signal Pin	2
DC Blocking Capacitor	2
USB Power Cord (2m)	1
9V Battery	1
Trimmer Tool	1
<b>Replacement accessories</b>	
N2792-68700	Differential probe accessory kit for N2818A/N2792A (including 2 each clip hook, 2 each alligator clip, and USB power cord)
N2793-68700	Differential probe accessory kit for N2819A/N2793A (including 2 each pincer clip, 2 each micro IC clip, 2 each extension lead 0.8 mm J-P 5 cm, 2 each extension lead 0.8 mm J-P 10 cm, 2 dual signal pins 16.8 mm, 2 dual signal pins 12.8 mm, 2 variable pitch spacing adapters, 2 DC blocking capacitors, 6 single signal pins 0.8 mm, USB power cord)
N4853A	Variable pitch browser for N2793A/N2819A, qty 2
N4854A	DC blocking caps for N2793A/N2819A, qty 2



# Using the N2792A Probe

Before using the probe, you must either install the supplied 9V battery or plug in the supplied USB power cord. The USB power cord can be connected either to the USB port on a computer or the oscilloscope. To install the battery, slide open the battery compartment located on the back side of the probe housing.



Battery Location



USB Power Cord Input

Figure 4 Location of Battery Compartment and USB Power Input

The probe's BNC output connector connects to the channel input of the oscilloscope. The oscilloscope must have a 50Ω input and be ground referenced.

---

## WARNING

**Must be Grounded. Before making connections to the input leads of this probe, ensure that the output BNC connector is attached to the BNC channel input of the oscilloscope and the oscilloscope is properly grounded.**



---

## CAUTION

To protect against electrical shock, use only the accessories supplied with this probe or in the accessory kit.

---

## CAUTION

This probe is to carry out differential measurements between two points on the circuit under test. This probe is not for electrically insulating the circuit under test and the measuring instrument.

---

**NOTE**

---

When battery life has expired, remove the battery. Observe the WEEE label on the battery and dispose of properly.

## Hook and Alligator Clips

Before you can use the N2792A probe, gently push the supplied hook clips or alligator clips onto the probe leads as shown in **Figure 5**. Use the hook clips to clamp onto smaller components and the alligator clips to clamp onto thicker gauge devices.

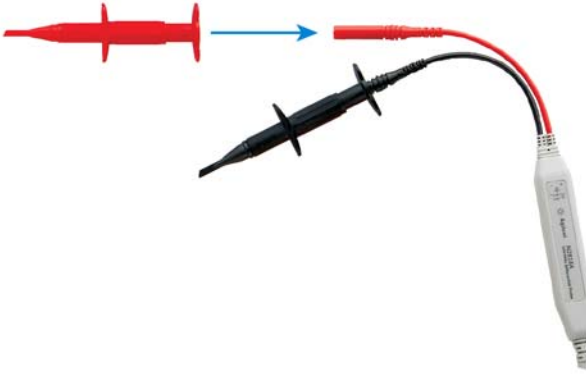

Figure 5 Inserting the Supplied Clips

# Using the N2793A Probe

Before using the probe, you must either install the supplied 9V battery or plug in the supplied USB power cord. The USB power cord can be connected either to the USB port on a computer or the oscilloscope. To install the battery, slide open the battery compartment located on the back side of the probe housing.



Battery Location



USB Power Cord Input

Figure 6 Location of Battery Compartment and USB Power Input

The probe's BNC output connector connects to the channel input of the oscilloscope. The oscilloscope must have a  $50\Omega$  input and be ground referenced.

---

## WARNING

**Must be Grounded. Before making connections to the input leads of this probe, ensure that the output BNC connector is attached to the BNC channel input of the oscilloscope and the oscilloscope is properly grounded.**



---

## CAUTION

To protect against electrical shock, use only the accessories supplied with this probe or in the accessory kit.

---

## CAUTION

This probe is to carry out differential measurements between two points on the circuit under test. This probe is not for electrically insulating the circuit under test and the measuring instrument.

**NOTE** When battery life has expired, remove the battery. Observe the WEEE label on the battery and dispose of properly.

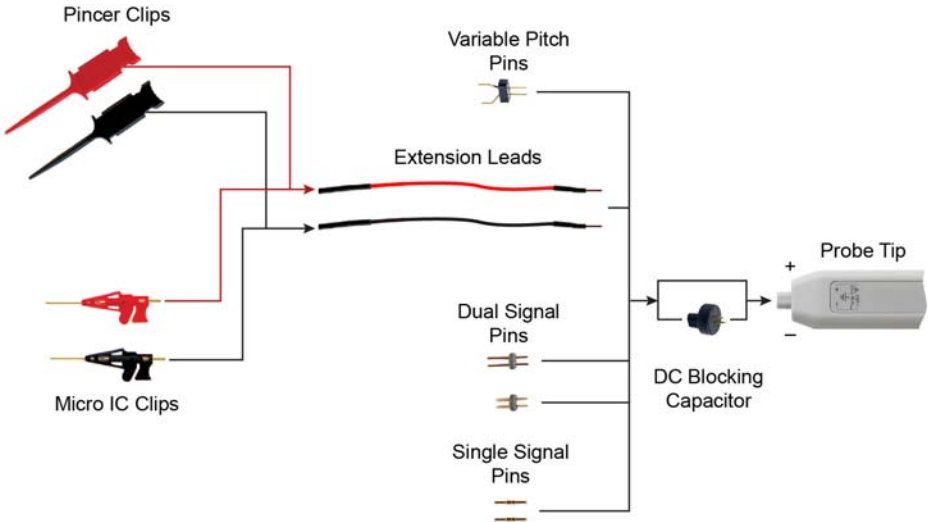

Figure 7 Probe Tip Accessory Connection Options

## Single, Dual, and Variable Pitch Signal Pins

Insert the single or dual signal pins into the probe tip as shown in figure 8. Directly probing with either one of these pins results in the best possible signal integrity when compared to the other probing accessories. The variable pitch spacing adapter allows you to easily probe two adjacent IC leads or test points. **Figure 9** shows the variable pitch pins inserted into the probe tip.

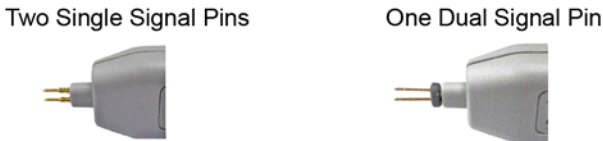

Figure 8 Signal Pins Inserted into the Probe Tip



Figure 9 Variable Pitch Pins Inserted into the Probe Tip

## Extension Leads

If the length of the signal pins is not adequate for your measurement setup or if you need to use the pincer or micro IC clips, the extension leads can be placed over the pins as shown below. The probe comes with both 5 cm and 10 cm long extensions leads.

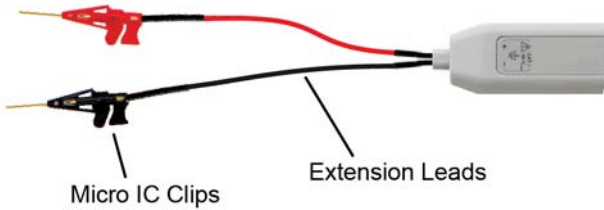

Figure 10 Extension Leads on Probe

## Micro IC Clips and Pincer Clips

Use the micro IC and pincer clips to probe miniature IC and components. These clips attach to the end of the extension leads. Squeeze the lever on the micro IC clips to extend the grasping jaws. Push the back of the pincer clips to extend their connectors.

## DC Blocking Capacitor

Use the DC blocking capacitor to block out unwanted DC components on the input signal.



Figure 11 DC Blocking Capacitor Inserted into the Probe Tip

# Safety Information

---

---

**WARNING**

To avoid personal injury and to prevent fire or damage to this product or products connected to it, review and comply with the following safety precautions. Be aware that if you use this probe assembly in a manner not specified, the protection this product provides may be impaired.

---

---

**WARNING**

Observe Maximum Working Voltage. To avoid injury, do not use the N2792A probe above 60V between each input lead and earth or between the two input leads and do not use the N2793A probe above 40V between each input lead and earth or between the two input leads.

---

---

**WARNING**

Must be Grounded. Before making connections to the input leads of this probe, ensure that the output BNC connector is attached to the BNC channel input of the oscilloscope and the oscilloscope is properly grounded.



---

---

**WARNING**

Do Not Operate Without Covers. To avoid electrical shock or fire hazard, do not operate this probe with the covers removed.

---

---

**WARNING**

Do Not Operate in Wet / Damp Conditions. To avoid electrical shock, do not operate this probe in wet or damp conditions.

---

---

**WARNING**

Do Not Operate in an Explosive Atmosphere. To avoid injury or fire hazard, do not operate this probe in an explosive atmosphere.

---

---

**WARNING**

Avoid Exposed Circuit. To avoid injury, remove jewelry such as rings, watches, and other metallic objects. Do not touch exposed connections and components when power is present.

---

---

**WARNING**

Use Proper Power Source. To ensure this probe functions well, use one 9V battery or the supplied USB power cord.

---

---

**WARNING**

For Indoor Use Only. Only use this probe indoors.

---

---

**WARNING**

Do Not Operate With Suspected Failures. If you suspect there is damage to this probe, have it inspected by a qualified service personnel.

# Specifications and Characteristics

The probe and oscilloscope should be warmed up for at least 20 minutes before any testing and the environmental conditions should not exceed the probe's specified limits.

---

## NOTE

---

Adhere to the specifications and characteristics listed in these tables to prevent damage to the probe and to keep the probe functioning properly.

**Table 3 N2792/3A Safety Specifications**

<b>Description</b>
CEI/IEC 61010-031 CAT II



Table 4 Electrical Specifications and Characteristics

Description	N2792A <sup>a</sup>	N2793A <sup>a</sup>
Bandwidth (-3 dB) <sup>b</sup>	200 MHz	800 MHz
Attenuation Ratio	10:1	10:1
Probe Risetime (10% - 90%)	1.75 ns	437 ps
Gain Accuracy (% of reading) <sup>b</sup>	±2%	±2%
Absolute Maximum Rated Input Voltage (each side to ground)	±60V	±40V
Maximum Differential Input Voltage (DC + AC Peak)	±20V	±15V
Maximum Common Mode Input Voltage	±60V	±30V
Input Resistance    Capacitance		
Each Side to Ground:	500 kΩ    7 pF	100 kΩ    2 pF
Between Inputs:	1 MΩ    3.5 pF	200 kΩ    1 pF
Output Voltage Swing	±2V (driving 50Ω scope input)	±1.5V (driving 50Ω scope input)
Offset (typical)	±2 mV (adjustable)	±5 mV (adjustable)
Offset Adjustment Range	-95 mV to +95 mV	-20 mV to +20 mV
AC CMRR	> -80 dB at 60 Hz > -50 dB at 10 MHz	> -60 dB at 60 Hz > -15 dB at 500 MHz
Noise Referenced to Input, Probe Only	6 mV <sub>rms</sub>	4.7 mV <sub>rms</sub>
Power Requirements	One 9V battery or USB power adapter (5V to 9V, 200 mA)	One 9V battery or USB power adapter (5V to 9V, 300 mA)
Approximate Battery Life	7.5 hours (alkaline battery)	4.5 hours (alkaline battery)
Battery/Power Cord	The supplied voltage must be less than 12V and greater than 4.5V or else the probe could be damaged.	

a. All entries are typical unless otherwise noted.

b. Warranted Specification.

Table 5 Mechanical Characteristics

Description	N2792A	N2793A
Approximate Weight (not including battery and accessories)	170g (6 oz)	170g (6 oz)
BNC Cable Length	120 cm (47 inches)	120 cm (47 inches)
Length of Input Leads	15 cm (5.9 inches)	n/a
Housing Dimensions (L x W x H)	111 mm x 22 mm x 14 mm (4.4 in x 0.9 in x 0.6 in)	111 mm x 22 mm x 14 mm (4.4 in x 0.9 in x 0.6 in)

Table 6 Environmental Specifications

Description	Specification
Temperature	Operating: -10 °C to +40 °C Non-operating: -30 °C to +70 °C
Altitude	Operating: 3,000 m (9,842 feet) Non-operating: 15,300 m (50,196 feet)
Humidity	Operating: 25 – 85% room humidity Non-operating: 25 – 85% room humidity
Pollution Degree	Pollution Degree 2

Table 7 DC Blocking Capacitor Electrical Characteristics

Description	Characteristic
Bandwidth (-3 dB)	30 kHz to 1 GHz
Impedance	50Ω
Maximum Input Range	100V
Insertion Loss (30 kHz to 1 GHz)	1.0 dB maximum
VSWR (30 kHz to 1 GHz)	1.35:1 maximum
Operating Temperature Range	-25 °C to +85 °C
Compatibility	With the N2793A and probe accessories
All are typical.	

# Performance Plots (N2792A Probe)

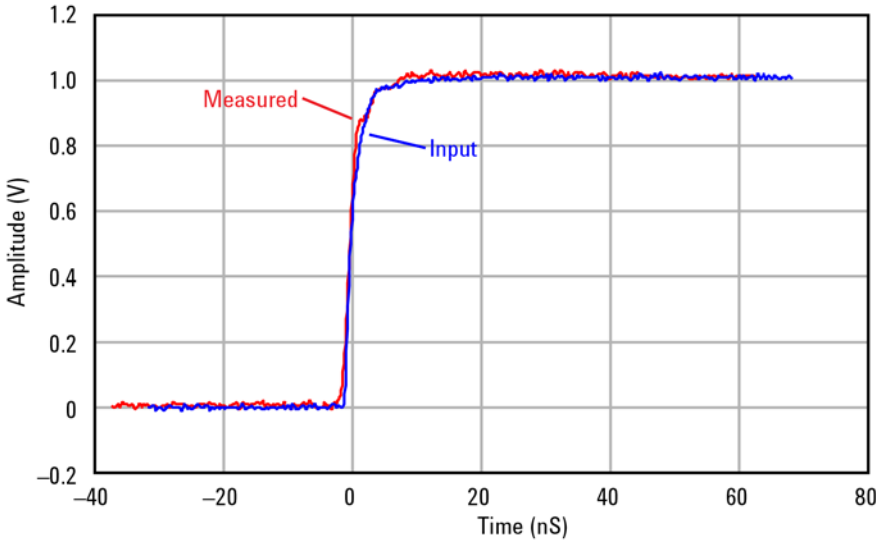

Input Step Signal	
10 - 90% rise time: .....	3.5 ns
20 - 80% rise time: .....	2.2 ns
Measured Step Response	
10 - 90% rise time: .....	3.5 ns
20 - 80% rise time: .....	2.2 ns

Figure 12 N2792A Normalized Differential Step Response (50Ω)

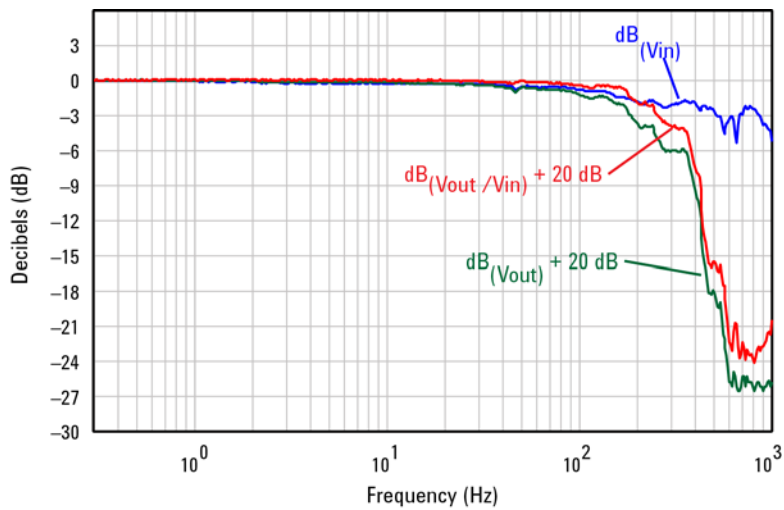

Figure 13 N2792A Frequency Response

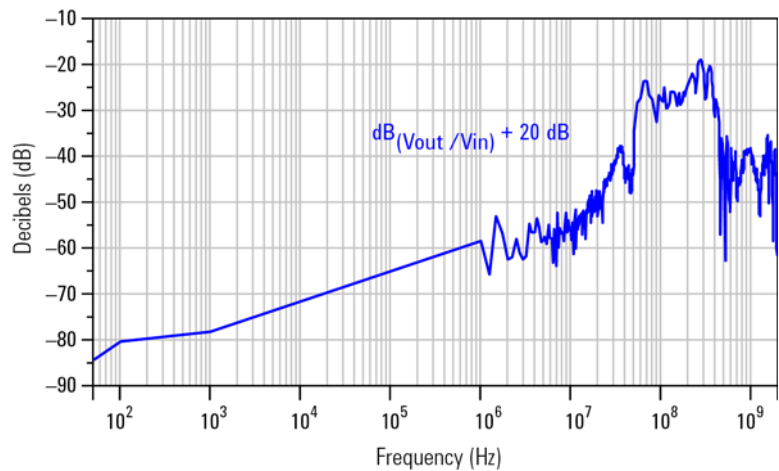

Figure 14 Frequency Response When Inputs Driven in Common Mode (CMRR)

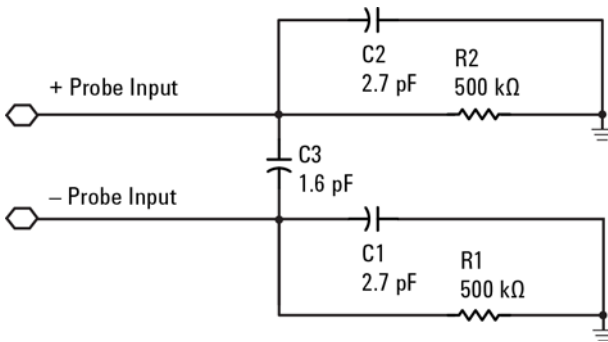

Figure 15 Input Impedance Equivalent Model With Measured Input Capacitance Values

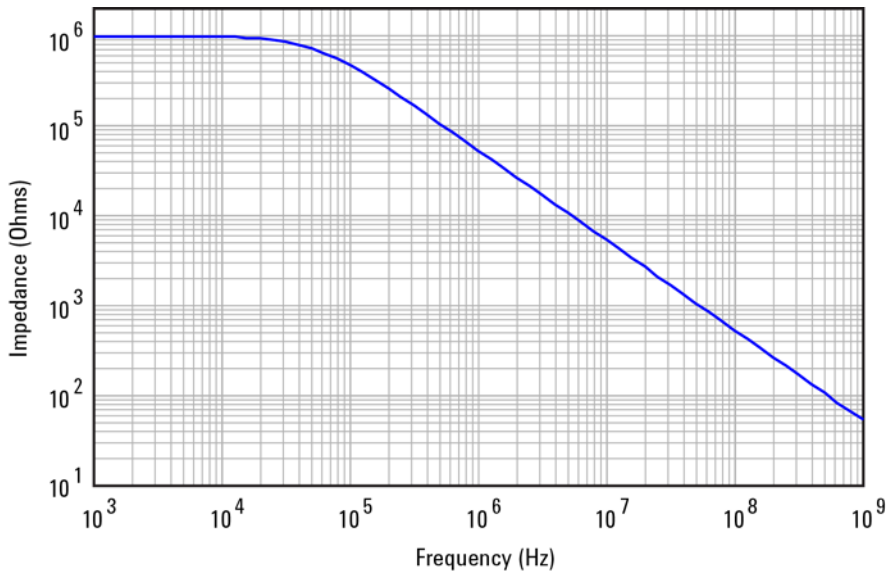

Figure 16 Typical Input Impedance Plot

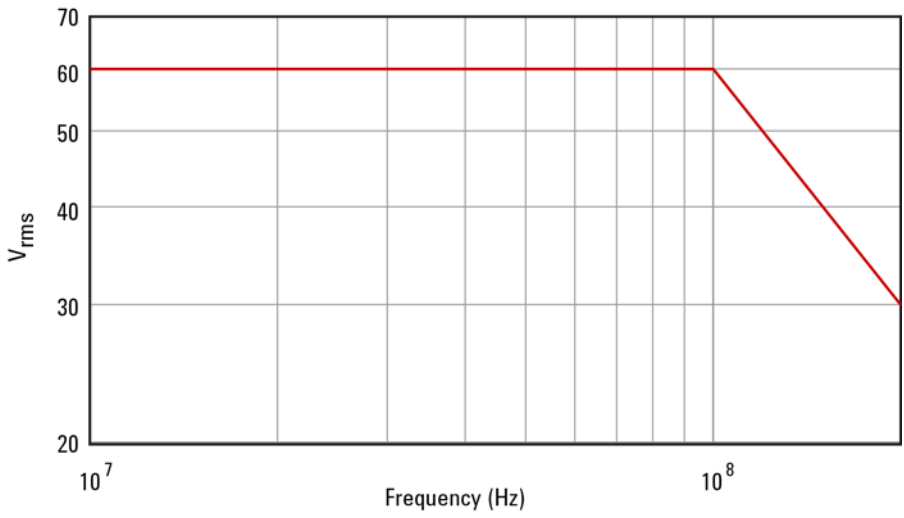
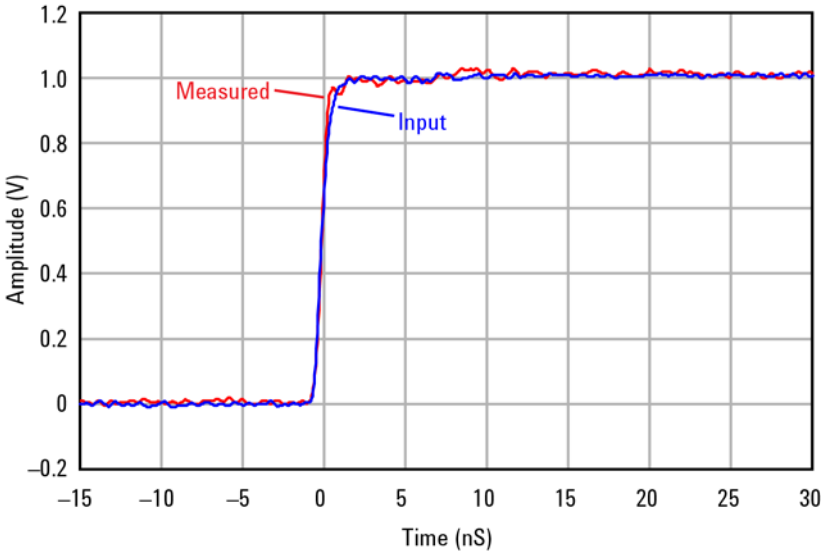

Figure 17 Typical Derating Curve of Absolute Maximum Input Voltage (Either Input to Ground)

# Performance Plots (N2793A Probe)



Input Step Signal	
10 - 90% rise time: .....	900 ps
20 - 80% rise time: .....	800 ps
Measured Step Response	
10 - 90% rise time .....	900 ps
20 - 80% rise time: .....	800 ps

Figure 18 N2793A Normalized Differential Step Response (50Ω)

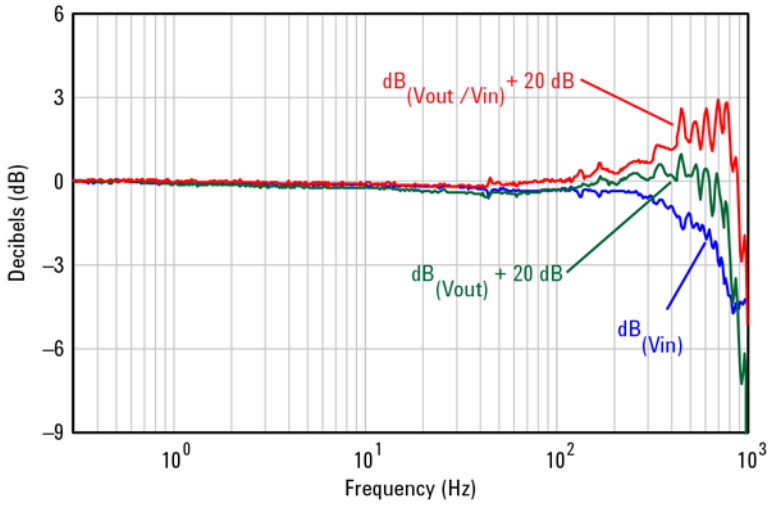

Figure 19 Frequency Response

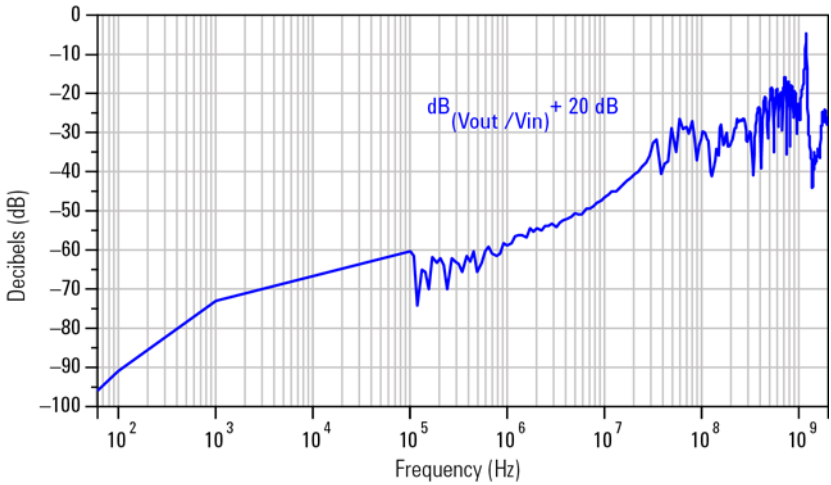

Figure 20 Frequency Response When Inputs Driven in Common Mode (CMRR)



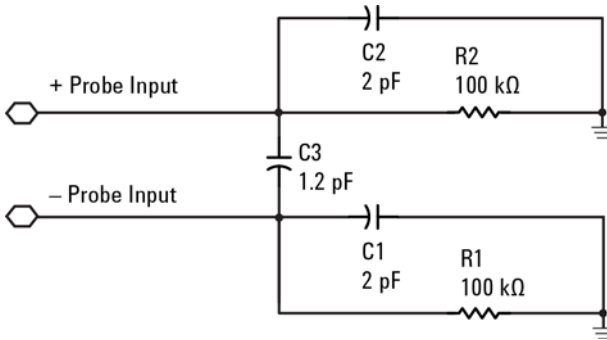

Figure 21 Input Impedance Equivalent Model With Measured Input Capacitance Values

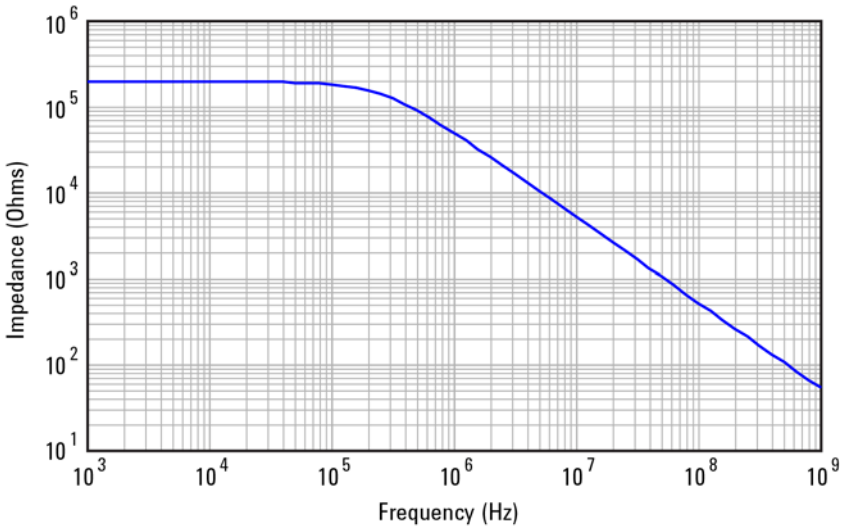

Figure 22 Typical Input Impedance Plot

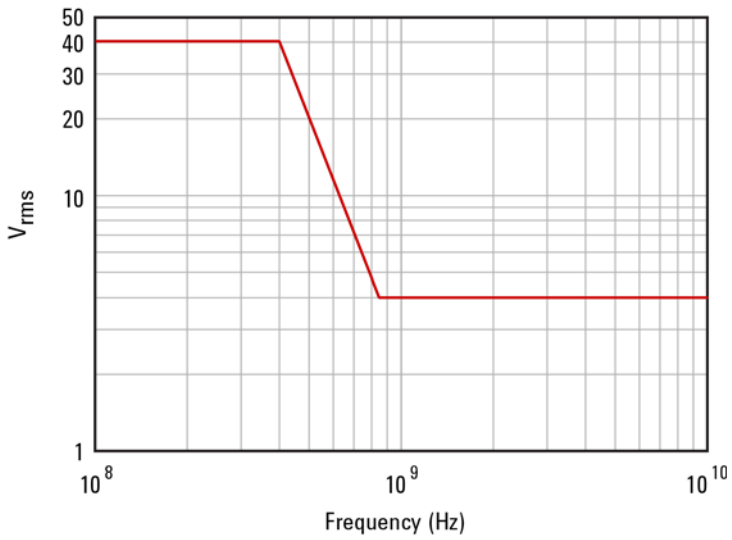

Figure 23 Typical Derating Curve of Absolute Maximum Input Voltage (Either Input to Ground)

# N2792A Performance Verification Procedures

The following procedure can be used to test the N2792A differential probe's DC differential gain accuracy and bandwidth, which are warranted specifications.

**Table 8 Required Test Equipment**

Description	Critical Specifications	Recommended Model Part Number	Functions
Digitizing Oscilloscope	Band width: >200 MHz 1 M $\Omega$ /50 $\Omega$ selectable input	Keysight DSOS254A	Display probe output
Signal Generator Precision DC voltage source	Amplitude accuracy: less than or equal to 0.25% 1 M $\Omega$ / 50 $\Omega$ selectable load Sine wave greater than or equal to 200 MHz	Fluke 9500B Or Keysight E8257D+1EU option	Signal source for DC gain and bandwidth
BNC Adapter	BNC (f) to Dual Banana (m) Adapter	Keysight 1251-2277	Interconnection between probe and generator
50 $\Omega$ BNC Feed Through Adapter	50 $\Omega$ precision feed through	Keysight 0960-0301	Termination between probe and calibrator for bandwidth verification

## Procedure

- 1 Configure the oscilloscope to the following settings:  
Amplitude Scale (Channel 1): ..... 20 mV/div  
Amplitude Scale (Channel 2): ..... 500 mV/div  
Time Scale: ..... 200  $\mu$ s/div  
Acquisition mode: ..... 32 averages  
Input impedance: ..... 50 $\Omega$   
Trigger: ..... Channel 2
- 2 On the 9500B calibrator, configure **CH2** to the following settings:  
Type: ..... TRIGGER  
Load: ..... 50 $\Omega$
- 3 On the 9500B, connect the **CH2** active head to channel 2 on the oscilloscope. Connect the **CH1** active head to channel 1 on the oscilloscope
- 4 On the N9500B, set **CH1** to the following settings and enable the output:  
Waveform: ..... square wave  
Load: ..... 1 M $\Omega$   
Amplitude: ..... 0.1V pk-pk  
Frequency: ..... 1 kHz
- 5 On the oscilloscope, select the amplitude measurement and record the DC amplitude (approximately 100 mV) of the square wave. This measurement is only the oscilloscope.
- 6 Disable the 9500B's output and disconnect the active head from channel 1 of the oscilloscope.
- 7 Connect the N2792A probe output to channel 1 of the oscilloscope.
- 8 Attach the BNC adapter to the 9500B's **CH1** active head.
- 9 Attach the differential probe input leads by clipping the alligator clamp to the BNC adapter banana post.
- 10 On the N9500B, configure **CH1** to the following settings and enable the output:  
Waveform: ..... square wave  
Load: ..... 1 M $\Omega$   
Amplitude: ..... 1V  
Frequency: ..... 1 kHz
- 11 Enable the output of the calibrator.
- 12 Record the DC amplitude of the square wave and divide 10 into just the amplitude of the oscilloscope. Verify that the probe gain accuracy is  $\pm 2\%$  + scope gain accuracy. Record the test results as DC Differential Gain Accuracy in Table 9 on page 30.

- 13 Disable the 9500B's output.
- 14 Connect the 50Ω BNC feed through adapter to the N9500B's **CH1** active head.
- 15 Attach the BNC (f)-to-banana post adapter to the BNC feed through adapter.
- 16 Attach the differential probe input leads by clipping the alligator clamp to the BNC adapter banana post.
- 17 Enable the 9500B's output.
- 18 Configure the oscilloscope to the following settings:  
 Amplitude Scale (Channel 1): ..... 50 mV/div  
 Time Scale: ..... 2 ns/div  
 Acquisition mode: ..... Peak Detect
- 19 Center the trace on the oscilloscope.
- 20 On the N9500B, configure **CH1** to the following settings:  
 Waveform: ..... sine wave  
 Load: ..... 50Ω  
 Amplitude: ..... 3V pk-pk  
 Frequency: ..... 200 MHz
- 21 Measure the peak-to-peak amplitude on the oscilloscope. It should be greater than or equal to 210 mV – scope vertical accuracy. Record the test results as Bandwidth in Table 9 on page 30.
- 22 Disable the N9500B's output and disconnect the probe input.

# N2792A Performance Verification Test Record

The recommended test interval is 1 year.

Table 9 N2792A Performance Test Record

Certification Details			
Serial Number:		Tested By:	
Certification Date:		Recommended Date of Next Certificaton:	
Certification Temperature:			
Test	Probe Setting	Test Limits	Test Results
DC Differential Gain	10:1	98 mV to 102 mV	
Bandwidth	10:1	≥ (210 mV – scope vertical accuracy)	

# N2793A Performance Verification Procedures

The following procedure can be used to test the N2793A high-voltage differential probe's DC differential gain accuracy and bandwidth, which are warranted specifications.

**Table 10 Required Test Equipment**

Description	Critical Specifications	Recommended Model Part Number	Functions
Digitizing Oscilloscope	Bandwidth: >1 GHz 1 M $\Omega$ /50 $\Omega$ selectable input	Keysight DSOS254A	Display probe output
Signal Generator Precision DC voltage source	Amplitude accuracy: less than or equal to 0.25% 1 M $\Omega$ /50 $\Omega$ selectable load Sine wave greater than or equal to 800 MHz	Fluke 9500B Or Keysight E8257D+1EU option	Signal source for DC gain and band width
Performance Check Fixture	50 $\Omega$ impedance controlled microstrip trace	Keysight E2655C	Probing trace for band width test
Terminator	50 $\Omega$ matched load		Termination for the PV fixture
BNC Adapter	BNC (f) to SMA (m)		Interconnection between calibrator and PV fixture
BNC Adapter	BNC(f) to Dual Banana (m) adapter	Keysight 1251-2277	Termination between probe and calibrator

## Procedure

- 1 Configure the oscilloscope to the following settings:
  - Amplitude Scale (Channel 1):..... 20 mV/div
  - Amplitude Scale (Channel 2):..... 500 mV/div
  - Time Scale:..... 200  $\mu$ s/div
  - Acquisition mode: ..... 32 averages
  - Input impedance:..... 50 $\Omega$ .
  - Trigger:..... Channel 2
- 2 On the 9500B calibrator, configure **CH2** to the following settings:
  - Type:..... TRIGGER
  - Load:..... 50 $\Omega$
- 3 On the 9500B, connect the **CH2** active head to channel 2 on the oscilloscope. Connect the **CH1** active head to channel 1 on the oscilloscope.
- 4 On the N9500B, set **CH1** to the following settings and enable the output:
  - Waveform: ..... square wave
  - Load: ..... 1 M $\Omega$
  - Amplitude: ..... 0.1V pk-pk
  - Frequency: ..... 1 kHz
- 5 On the oscilloscope, select the amplitude measurement and record the DC amplitude (approximately 100 mV) of the square wave. This measurement is only the oscilloscope.
- 6 Disable the 9500B's output and disconnect the active head from channel 1 of the oscilloscope.
- 7 Connect the N2793A probe output to channel 1 of the oscilloscope.
- 8 Attach the BNC adapter to the 9500B's **CH1** active head.
- 9 Attach the differential probe input leads by clipping the alligator clamp to the BNC adapter banana post.
- 10 On the N9500B, configure **CH1** to the following settings and enable the output:
  - Waveform: ..... square wave
  - Load: ..... 1 M $\Omega$
  - Amplitude: ..... 1V
  - Frequency: ..... 1 kHz
- 11 Enable the output of the calibrator.
- 12 Record the DC amplitude of the square wave and divide 10 into just the amplitude of the oscilloscope. Verify that the probe gain accuracy is  $\pm 2\%$  + scope gain accuracy. Record the test results as DC Differential Gain Accuracy in Table 11 on page 34.



- 13 Disable the 9500B's output.
- 14 Connect the E2655C PV fixture to the N9500B's **CH1** active head.
- 15 Configure the oscilloscope to the following settings:  
 Amplitude Scale (Channel 2):..... 500 mV/div
- 16 On the 9500B calibrator, configure **CH2** to the following settings:  
 Type:..... TRIGGER  
 Load:..... 50 $\Omega$
- 17 On the 9500B, connect the **CH2** active head to channel 2 on the oscilloscope.
- 18 Terminate PV fixture's 50 $\Omega$  trace with the matched 50 $\Omega$  terminator.
- 19 Insert the probe's dual signal pins into the probe tip.
- 20 Use a probe positioner to gently place the probe pin tips onto the PV fixture's center conductor and ground plane as identified in **Figure 24** on page 33.

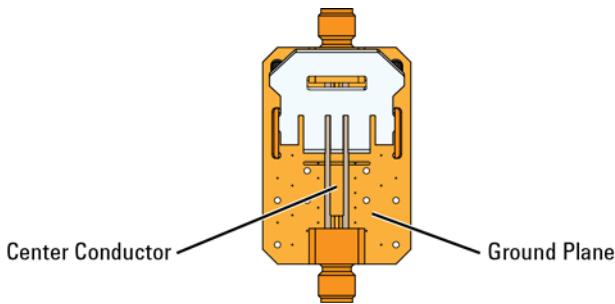

Figure 24 Probing Locations on PV Fixture

- 21 Enable the 9500B's output.
- 22 Configure the oscilloscope to the following settings:  
 Amplitude Scale (Channel 1):..... 50 mV/div  
 Time Scale:..... 2 ns/div  
 Acquisition mode:..... Peak Detect
- 23 Center the trace on the oscilloscope.
- 24 On the N9500B, configure **CH1** to the following settings:  
 Waveform:.....sine wave  
 Load:..... 50 $\Omega$   
 Amplitude:..... 3V pk-pk  
 Frequency:..... 800 MHz

**25** Measure the peak-to-peak amplitude on the oscilloscope. It should be greater than or equal to 210 mV – scope vertical accuracy. Record the test results as Bandwidth in Table 11 on page 34.

**26** Disable the N9500B's output and disconnect the probe input.

## N2793A Performance Verification Test Record

The recommended test interval is 1 year.

Table 11 N2793A Performance Test Record

Certification Details			
Serial Number:		Tested By:	
Certification Date:		Recommended Date of Next Certificaton:	
Certification Temperature:			
Test	Probe Setting	Test Limits	Test Results
DC Differential Gain	10:1	98 mV to 102 mV	
Band width	10:1	$\geq$ (210 mV – scope vertical accuracy)	

# Offset Zero Calibration Procedure

The N2792A/N2793A differential probe can be adjusted for zeroing out the probe's offset voltage using the trimmer tool supplied with the probe. Follow this procedure to perform the offset zero calibration.

- 1 After turning on power to the oscilloscope and probe, leave them on for >30 minutes to stabilize. You may use the USB power cord or batteries to power the probe.
- 2 Connect the probe to channel 1 of the oscilloscope.
- 3 Short the + and - probe inputs together with the hook tips.
- 4 Press **[Default Setup]** and **[Auto Scale]** on the oscilloscope.
- 5 Press the channel 1 key, then the Probe softkey, and then set the units to Volt and the probe attenuation to 10:1
- 6 Set the oscilloscope to DC coupled mode.
- 7 Position the ground of the waveform to the center of the screen and set the vertical scale to 10 mV/div or 20 mV/div.
- 8 Set the oscilloscope to Averaging mode (x8 or higher) or High resolution mode to reduce scope noise.
- 9 Using the trimmer tool that comes with the probe, adjust the probe offset voltage to 0 V.





# Index

- A
  - accessories
    - N2792A 6
    - N2793A 7
  - alligator clips 6, 10
  - attenuation ratio 4
- B
  - battery compartment 9, 11
- C
  - characteristics 16
  - cleaning 5
  - compatible oscilloscopes 4
- D
  - DC blocking capacitor 14
  - differential measurements 9
  - dual signal pins 12
- E
  - Environmental 18
  - environmental specifications 18
  - extension leads 13
- G
  - grounding probe 9, 11
- H
  - handling 4
  - hook clips 6, 10
- I
  - input impedance equivalent model
    - N2792A 21
    - N2793A 25
- inspecting probe 5
- internal battery 4
- M
  - mechanical characteristics 18
  - micro IC clips 13
- N
  - N2792A
    - accessories 6
    - performance plots 19
    - performance verification 27
  - N2793A
    - accessories 7
    - performance plots 23
    - performance verification 31
- O
  - oscilloscopes
    - compatible 4
- P
  - performance plots
    - N2792A 19
    - N2793A 23
  - performance verification
    - N2792A 27
    - N2793A 31
  - pincer clips 13
  - probe
    - battery compartment 9, 11
    - cleaning 5
    - grounding 9, 11
    - USB power input 9, 11

probe cleaning 5  
probe handling 4  
probe inspection 5

## R

replacement kit 6, 7

## S

safety information 15  
safety specifications 16  
single signal pins 12

## U

USB power cord 9, 11  
USB power input 9, 11

## V

variable pitch pins 12