

Keysight N5224A and N5225A
2-Port and 4-Port PNA
Microwave Network Analyzers
(10 MHz - 43.5 GHz)
(10 MHz - 50 GHz)

NOTICE: This document contains references to Agilent Technologies. Agilent's former Test and Measurement business has become Keysight Technologies. For more information, go to www.keysight.com.



Notices

© Keysight Technologies 2011 - 2014

No part of this manual may be reproduced in any form or by any means (including electronic storage and retrieval or translation into a foreign language) without prior agreement and written consent from Keysight Technologies as governed by United States and international copyright laws.

Manual Part Number

N5225-90001

Edition

December 1, 2014

Published in USA
Keysight Technologies
5301 Stevens Creek Blvd
Santa Clara, CA 95051 USA

Warranty

The material contained in this document is provided “as is,” and is subject to being changed, without notice, in future editions. Further, to the maximum extent permitted by applicable law, Keysight disclaims all warranties, either express or implied, with regard to this manual and any information contained herein, including but not limited to the implied warranties of merchantability and fitness for a particular purpose. Keysight shall not be liable for errors or for incidental or consequential damages in connection with the furnishing, use, or performance of this document or of any information contained herein. Should Keysight and the user have a separate written agreement with warranty terms covering the material in this document that conflict with these terms, the warranty terms in the separate agreement shall control.

Technology Licenses

The hardware and/or software described in this document are furnished under a license and may be used or copied only in accordance with the terms of such license.

Restricted Rights Legend

If software is for use in the performance of a U.S. Government prime contract or subcontract, Software is delivered and licensed as “Commercial computer software” as defined in DFAR 252.227-7014 (June 1995), or as a “commercial item” as defined in FAR 2.101(a) or as “Restricted

computer software” as defined in FAR 52.227-19 (June 1987) or any equivalent agency regulation or contract clause. Use, duplication or disclosure of Software is subject to Keysight Technologies’ standard commercial license terms, and non-DOD Departments and Agencies of the U.S. Government will receive no greater than Restricted Rights as defined in FAR 52.227-19(c)(1-2) (June 1987). U.S. Government users will receive no greater than Limited Rights as defined in FAR 52.227-14 (June 1987) or DFAR 252.227-7015 (b)(2) (November 1995), as applicable in any technical data.

Safety Notices

CAUTION

A **CAUTION** notice denotes a hazard. It calls attention to an operating procedure, practice, or the like that, if not correctly performed or adhered to, could result in damage to the product or loss of important data. Do not proceed beyond a **CAUTION** notice until the indicated conditions are fully understood and met.

WARNING

A **WARNING** notice denotes a hazard. It calls attention to an operating procedure, practice, or the like that, if not correctly performed or adhered to, could result in personal injury or death. Do not proceed beyond a **WARNING** notice until the indicated conditions are fully understood and met.

Documentation Map

The online Help files are embedded in the analyzer, offering quick reference to programming and user documentation. From the Help drop-down menu, you can access the Help system in five different languages. Also, you can view the Analyzer Product Overview multimedia presentation and access the analyzer's Web page.

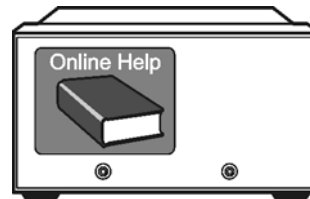

The *Installation and Quick Start Guide* helps you to quickly familiarize yourself with the analyzer. Procedures are provided for installing, configuring, and verifying the operation of the analyzer.

Printing Copies of Documentation from the Web

To print copies of documentation from the Web, download the PDF file from the Keysight web site:

- Go to <http://www.keysight.com>.
- Enter the product model number (Ex: N5225A) in the Search box.
- Click the Search icon (magnifying glass).
- Click the **Manuals** hyperlink.
- Click the hyperlink title for the document you want to print - this downloads the PDF
- Print the document after the PDF has fully downloaded.

1 Safety and Regulatory Information

Information in This Chapter	1-2
Chapter One at-a-Glance	1-2
Safety Symbols	1-3
General Safety Considerations	1-3
Safety Earth Ground	1-3
Before Applying Power	1-3
Servicing	1-4
Electrostatic Discharge Protection	1-6
Regulatory Information	1-7
Instrument Markings	1-7
Lithium Battery Disposal	1-8

2 General Product Information

Information in This Chapter	2-2
Chapter Two at-a-Glance	2-2
Maintenance	2-3
Physical Maintenance	2-3
Electrical Maintenance	2-3
Analyzer Options, Accessories, and Upgrades Available	2-4
Pulse I/O Adapter-N1966A	2-4
Required Service Test Equipment	2-5
Keysight Support, Services, and Assistance	2-8
Service and Support Options	2-8
Contacting Keysight	2-8
Shipping Your Analyzer to Keysight for Service or Repair	2-9

3 Tests and Adjustments

Information in This Chapter	3-2
Conventions Used for Hardkeys, Softkeys, and Menu Items	3-2
Chapter Three at-a-Glance	3-2
Before You Begin	3-4
Verify the Operating Environment	3-4
Protect Against Electrostatic Discharge (ESD)	3-4
Allow the Analyzer to Warm Up	3-4
Review the Principles of Connector Care	3-5
About System Verification and Performance Tests	3-6
System Specifications	3-6
Instrument Specifications	3-6
System Verification Procedure	3-6
Performance Tests	3-7
Certificate of Calibration	3-7
ANSI/NCSL Z540.3–2006 and ISO/IEC 17025 Verification	3-8
Non-Standards Compliant Verification	3-9
Preliminary Checks	3-10
The Operator's Check	3-10
The Test Port Cable Checks	3-12
System Verification	3-19

What the System Verification Verifies	3-19
Measurement Uncertainty	3-20
Measurement Traceability	3-21
Performing System Verification	3-22
Performance Tests	3-28
Source Power Accuracy Test	3-29
Source Maximum Power Output Test	3-30
Source Power Linearity Test	3-31
Frequency Accuracy Test	3-32
Trace Noise Test	3-33
Receiver Compression Test	3-34
Noise Floor Test	3-36
Calibration Coefficients Test	3-37
Dynamic Accuracy Test	3-38
Adjustments	3-39
10 MHz Frequency Reference Adjustment	3-40
IF Gain Adjustment	3-41
Synthesizer Bandwidth Adjustment	3-41
Source Adjustment	3-42
Receiver Adjustment	3-43
Receiver Characterization	3-46
EE Default Adjustment	3-46
4 Troubleshooting	
Information in This Chapter	4-2
Chapter Four at-a-Glance	4-2
Conventions Used for Hardkeys, Softkeys, and Menu Items	4-3
Operating the Analyzer With Covers Removed	4-3
Protect Against Electrostatic Discharge (ESD)	4-3
Assembly Replacement Sequence	4-3
Getting Started with Troubleshooting	4-4
Check the Basics	4-4
Troubleshooting Organization	4-4
Power Up Troubleshooting	4-6
Power Supply Check	4-7
Troubleshooting LCD Display Problems	4-12
Front Panel Troubleshooting	4-13
Front Panel Keypad and RPG Test	4-13
A3 Display Test	4-15
Checking the A2 USB Board	4-16
A1 Front Panel Interface Board	4-16
Rear Panel Troubleshooting	4-17
Checking the USB Ports	4-17
Checking the CONTROLLER Port	4-17
LAN Troubleshooting	4-18
Measurement System Troubleshooting	4-23
Before you begin—consider: Where do you see a problem?	4-23
Verifying the A, B, C, D, and R Traces (Standard S-Parameter Mode)	4-26
Where to Begin Troubleshooting	4-28

Checking the Source Group	4-30
Checking the Signal Separation Group	4-35
Checking the Receiver Group	4-39
Instrument Block Diagrams Sheet 1	4-43
Microwave PNA, N522xA	4-43
Instrument Block Diagrams Sheet 2	4-45
Microwave PNA, N522xA	4-45
5 Theory of Operation	
Information in This Chapter	5-2
Chapter Five at-a-Glance	5-2
Network Analyzer System Operation	5-3
Functional Groups of the Network Analyzer	5-4
Synthesized Source Group Operation	5-7
Basic Operation	5-7
A4, A15, and A17 13.5 GHz Synthesizer Boards	5-11
A5 and A10 26.5 GHz Source Boards	5-11
A7, A8, A12, and A13 50 GHz Doubler Boards	5-12
A25 Multiplier/Amplifier 26.5 Board (HMA26.5)	5-12
A14 Frequency Reference Board	5-12
A23 Test Set Motherboard	5-13
Signal Separation Group Operation	5-17
Configurable Test Set	5-17
A29–A32 Receiver Couplers	5-18
A33–A36 Test Port Couplers	5-18
A38–A41 60-dB Source Step Attenuators and A42–A45 Bias Tees	5-18
Receiver Group Operation	5-21
A46–A49 35-dB Receiver Step Attenuators	5-21
A37 Reference Mixer Switch	5-21
A27 and A28 Mixer Bricks	5-21
A16 SPAM Board (Analog Description)	5-22
A24 IF Multiplexer Board	5-22
Digital Processing and Digital Control Group Operation	5-26
Front Panel Subgroup	5-28
Data Acquisition and Processing Subgroup	5-28
Power Supply Group Operation	5-31
6 Replaceable Parts	
Information in This Chapter	6-3
Chapter Six at-a-Glance	6-3
Ordering Information	6-4
Assembly Replacement Sequence	6-4
Rebuilt-Exchange Assemblies	6-5
Replaceable Parts Listings	6-6
Front Panel Assembly, Front Side, All Options	6-10
Front Panel Assembly, Back Side, All Options	6-12
Top Assemblies and Cables, All Options	6-16
2-Port Configuration, Option 200	6-22

2-Port Configuration, Option 201	6-28
2-Port Configuration, Option 210	6-34
2-Port Configuration, Option 217	6-40
2-Port Configuration, Option 219	6-46
4-Port Configuration, Option 400	6-52
4-Port Configuration, Option 401	6-58
4-Port Configuration, Option 410	6-64
4-Port Configuration, Option 417	6-70
4-Port Configuration, Option 419	6-78
Rear Panel Assembly, All Options	6-86
Fan Assemblies, All Options	6-88
Top Hardware and Miscellaneous Parts, All Options	6-90
Bottom Hardware and Miscellaneous Parts	6-92
Internal Hardware and Miscellaneous Parts, All Options	6-94
External Hardware and Miscellaneous Parts, All Options	6-96
Miscellaneous Part Numbers	6-98

7 Repair and Replacement Procedures

Information in This Chapter	7-2
Chapter Seven at-a-Glance	7-2
Personal Safety Warnings	7-3
Electrostatic Discharge (ESD) Protection	7-3
Removal and Replacement Procedures	7-4
Removing the Covers	7-6
Removing and Replacing the Front Panel Assembly	7-8
Removing and Replacing the A1–A3 and Other Front Panel Subassemblies	7-10
Removing and Replacing the A4–A17 Boards	7-14
Removing and Replacing the A18 System Motherboard	7-16
Removing and Replacing the A19 Midplane Board	7-18
Removing and Replacing the A20 Power Supply Assembly	7-20
Removing and Replacing the A21 CPU Board Assembly	7-22
Removing and Replacing the A22 GPIB Board	7-24
Removing and Replacing the A23 Test Set Motherboard	7-26
Removing and Replacing the A24 IF Multiplexer Board	7-28
Removing and Replacing the A25 HMA26.5	7-30
Removing and Replacing the A26 Splitter	7-32
Removing and Replacing the A27 and A28 Mixer Bricks	7-34
Removing and Replacing the A29–A32 Receiver Couplers and Receiver Coupler Mounting Brackets	7-36
Removing and Replacing the A33–A36 Test Port Couplers	7-38
Removing and Replacing the A37 Reference Mixer Switch	7-40
Removing and Replacing the A38–A41 Source Attenuators and the A46–A49 Receiver Attenuators	7-42
Removing and Replacing the A42–A45 Bias Tees	7-44
Removing and Replacing the A55 Solid State Drive (SSD)	7-46
Removing and Replacing the Rear Panel	7-48
Removing and Replacing the Front Panel LED Boards	7-50
Removing and Replacing the Fans	7-52
Removing and Replacing the Lithium Battery	7-54
Post-Repair Procedures	7-56

8 General Purpose Maintenance Procedures

Information in This Chapter	8-2
Chapter Eight at-a-Glance	8-2
Conventions Used for Hardkeys, Softkeys, and Menu Items	8-2
Error Terms	8-3
Using Error Terms as a Diagnostic Tool	8-3
Performing Measurement Calibration	8-3
Using Flowgraphs to Identify Error Terms	8-4
Accessing Error Terms	8-8
Error Term Data	8-10
Option Enable Utility	8-13
Accessing the Option Enable Utility	8-13
Option Entitlement Certificate	8-13
Enabling or Removing Options	8-14
Repairing and Recovering Option Data	8-15
Installing or Changing a Serial Number	8-16
Firmware Upgrades	8-17
How to Check the Current Firmware Version	8-17
Downloading from the Internet	8-17
Operating System Recovery	8-18
Recovering from Solid State Drive Problems	8-18
Correction Constants	8-19
Storing Correction Constants	8-19

1 Safety and Regulatory Information

Information in This Chapter

This chapter provides safety information that will help protect you and your network analyzer. It also contains information that is required by various government regulatory agencies.

Chapter One at-a-Glance

Section Title	Summary of Content	Start Page
Safety Symbols	Descriptions of CAUTION and WARNING symbols used throughout this manual.	Page 1-3
General Safety Considerations	A list of safety points to consider when servicing your network analyzer.	Page 1-3
Electrostatic Discharge Protection	A discussion of electrostatic discharge (ESD) and related recommendations and requirements for ESD protection.	Page 1-6
Regulatory Information	Definitions of instrument markings. Instructions for disposing of the analyzer's lithium battery.	Page 1-7

Safety Symbols

The following safety symbols are used throughout this manual. Familiarize yourself with each of the symbols and its meaning before operating this instrument.

CAUTION Caution denotes a hazard. It calls attention to a procedure that, if not correctly performed or adhered to, could result in damage to or destruction of the instrument. Do not proceed beyond a caution note until the indicated conditions are fully understood and met.

WARNING Warning denotes a hazard. It calls attention to a procedure which, if not correctly performed or adhered to, could result in injury or loss of life. Do not proceed beyond a warning note until the indicated conditions are fully understood and met.

General Safety Considerations

Safety Earth Ground

WARNING This is a Safety Class I product (provided with a protective earthing ground incorporated in the power cord). The mains plug shall only be inserted in a socket outlet provided with a protective earth contact. Any interruption of the protective conductor, inside or outside of the instrument, will make the instrument dangerous. Intentional interruption is prohibited.

CAUTION Always use the three-prong AC power cord supplied with this product. Failure to ensure adequate grounding by not using this cord may cause product damage.

Before Applying Power

WARNING If this product is not used as specified, the protection provided by the equipment could be impaired. This product must be used in a normal condition (in which all means for protection are intact) only.

WARNING If an instrument handle is damaged, you should replace it immediately. Damaged handles can break while you are moving or lifting the instrument and cause personal injury or damage to the instrument.

CAUTION This instrument has autoranging line voltage input. Be sure the supply voltage is within the specified range.

WARNING Supply voltages which oscillate between the two normal input ranges of the autoranging line voltage input will damage the power supply. In rare cases, this damage has become a user safety concern. If unstable power levels are expected, the analyzer input power must be buffered by a line conditioner.

CAUTION This product is designed for use in Installation Category II and Pollution Degree 2 per IEC 61010-1:2001 and 664 respectively.

CAUTION Do not operate the analyzer with the outer cover removed for more than 30 minutes, as this could cause the analyzer to overheat which could result in costly damage.

CAUTION **Ventilation Requirements:** When installing the product in a cabinet, the convection into and out of the product must not be restricted. The ambient temperature (outside the cabinet) must be less than the maximum operating temperature of the instrument by 4 °C for every 100 watts dissipated in the cabinet. If the total power dissipated in the cabinet is greater than 800 watts, then forced convection must be used.

CAUTION The measuring terminals on this instrument are designed to be used with external signals described in Measurement Category I, but NOT with external signals described in Categories II, III, and IV. The input of this instrument cannot be connected to the mains.

Servicing

WARNING These servicing instructions are for use by qualified personnel only. To avoid electrical shock, do not perform any servicing unless you are qualified to do so.

WARNING Danger of explosion if battery is incorrectly replaced. Replace only with the same or equivalent type recommended. Discard used batteries according to local ordinances and/or manufacturer's instructions.

WARNING Procedures described in this document may be performed with power supplied to the product while protective covers are removed. Energy available at many points may, if contacted, result in personal injury.

CAUTION Do not operate the analyzer with the outer cover removed for more than 30 minutes, as this could cause the analyzer to overheat which could result in costly damage.

WARNING No operator serviceable parts inside. Refer servicing to qualified personnel. To prevent electrical shock, do not remove covers.

WARNING The opening of covers or removal of parts may expose dangerous voltages. Disconnect the instrument from all voltage sources while it is being opened.

WARNING The detachable power cord is the instrument disconnecting device. It disconnects the mains circuits from the mains supply before other parts of the instrument. The front panel switch is only a standby switch and is not a LINE switch (disconnecting device).

NOTE There are no replaceable fuses in the mains input or within the power supply assembly.

IMPORTANT Keysight personnel: after calibration is completed, attach four "calibration void if seal broken" stickers to the PNA as shown in [Figure 1-1](#).

Figure 1-1 Location of Calibration Stickers on PNA

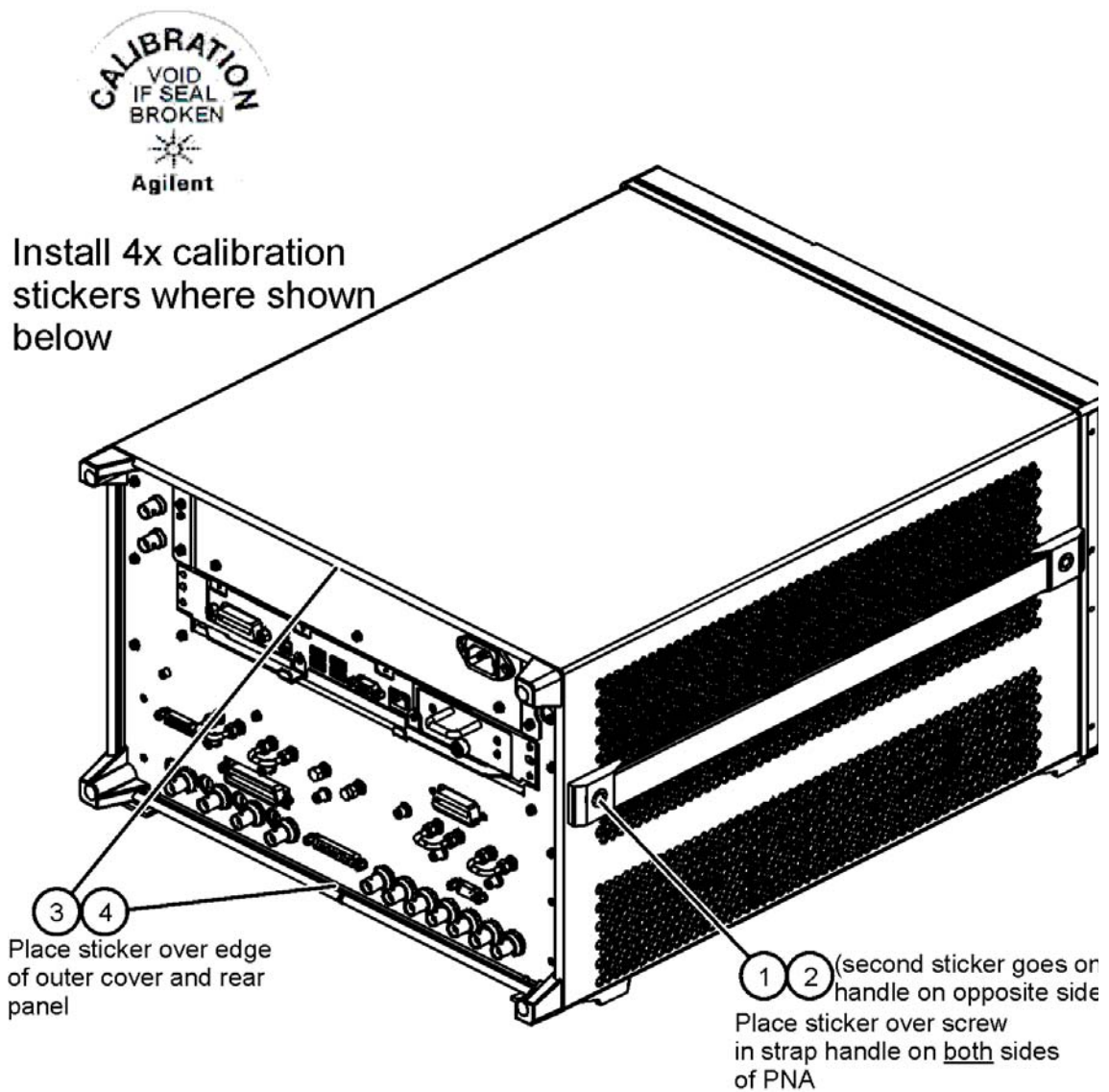

Electrostatic Discharge Protection

Protection against electrostatic discharge (ESD) is essential while removing assemblies from or connecting cables to the network analyzer. Static electricity can build up on your body and can easily damage sensitive internal circuit elements when discharged. Static discharges too small to be felt can cause permanent damage. To prevent damage to the instrument:

- *always* have a grounded, conductive table mat in front of your test equipment.
- *always* wear a grounded wrist strap, connected to a grounded conductive table mat, having a 1 M Ω resistor in series with it, when handling components and assemblies or when making connections.
- *always* wear a heel strap when working in an area with a conductive floor. If you are uncertain about the conductivity of your floor, wear a heel strap.
- *always* ground yourself before you clean, inspect, or make a connection to a static-sensitive device or test port. You can, for example, grasp the grounded outer shell of the test port or cable connector briefly.
- *always* ground the center conductor of a test cable before making a connection to the analyzer test port or other static-sensitive device. This can be done as follows:
 1. Connect a short (from your calibration kit) to one end of the cable to short the center conductor to the outer conductor.
 2. While wearing a grounded wrist strap, grasp the outer shell of the cable connector.
 3. Connect the other end of the cable to the test port and remove the short from the cable.

Figure 1-2 shows a typical ESD protection setup using a grounded mat and wrist strap. Refer to [Table 6-3, "Part Numbers for Miscellaneous Parts and Accessories,"](#) on page 6-98 for part numbers.

Figure 1-2 ESD Protection Setup

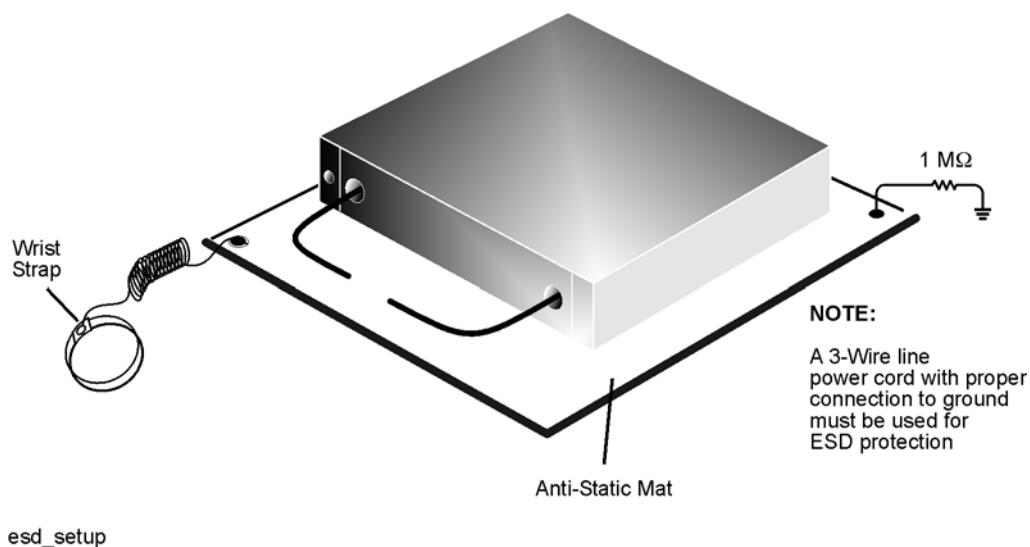

Regulatory Information

This section contains information that is required by various government regulatory agencies.

Instrument Markings

NOTE Some instrument markings may not appear on your analyzer.



The instruction documentation symbol. The product is marked with this symbol when it is necessary for the user to refer to the instructions in the documentation.



The AC symbol indicates the required nature of the line module input power.



This symbol indicates separate collection for electrical and electronic equipment, mandated under EU law as of August 13, 2005. All electric and electronic equipment are required to be separated from normal waste for disposal (Reference WEEE Directive, 2002/96/EC).



This symbol indicates that the power line switch is ON.



This symbol indicates that the power line switch is in the STANDBY position.



This symbol indicates that the power line switch is in the OFF position.



This symbol is used to identify a terminal which is internally connected to the product frame or chassis.



The CE mark is a registered trademark of the European Community. (If accompanied by a year, it is when the design was proven.)



The CSA mark is a registered trademark of the CSA International.



This mark designates the product is an Industrial Scientific and Medical Group 1 Class A product (reference CISPR 11, Clause 5).



This is a marking to indicate product compliance with the Canadian Interference-Causing Equipment Standard (ICES-001).



Direct Current.



The instrument has been designed to meet the requirements of IP 2 0 for ingress and operational environment.



The RCM mark is a registered trademark of the Australian Communications and Media Authority.



Indicates the time period during which no hazardous or toxic substance elements are expected to leak or deteriorate during normal use. Forty years is the expected useful life of the product.



This symbol on all primary or secondary packaging indicates compliance to China standard GB 18455-2001.



South Korean Certification (KC) mark; includes the marking's identifier code which follows the format: MSIP-REM-YYY-ZZZZZZZZZZZZZZ or KCC-REM-YYY-ZZZZZZZZZZZZ.

Lithium Battery Disposal

If the battery on the A21 CPU board assembly needs to be disposed of, dispose of it in accordance with your country's requirements. If required, you may return the battery to Keysight Technologies for disposal. Refer to ["Contacting Keysight" on page 2-8](#) for assistance.



DO NOT THROW BATTERIES AWAY BUT
COLLECT AS SMALL CHEMICAL WASTE.

For instructions on removing and replacing the battery on the A21 CPU board assembly, refer to ["Removing and Replacing the Lithium Battery" on page 7-54](#).

2 General Product Information

Information in This Chapter

Chapter Two at-a-Glance

Section Title	Summary of Content	Start Page
Maintenance	Cleaning instructions for the external surfaces of your analyzer. Information about electrical maintenance of your analyzer.	Page 2-3
Analyzer Options, Accessories, and Upgrades Available	A hyperlink to the PNA Configuration Guide, which includes a list of options, accessories, and upgrades available for the microwave network analyzers.	Page 2-4
Required Service Test Equipment	A list of service equipment that is required to perform system verification, performance tests, adjustments, and troubleshooting.	Page 2-5
Keysight Support, Services, and Assistance	The Internet address (URL) for on-line assistance. Service and support options available. Calibration options available. Important information about shipping your analyzer to Keysight for service or repair.	Page 2-8

Maintenance

Physical Maintenance

WARNING To prevent electrical shock, disconnect the analyzer from the mains source before cleaning. Use a dry cloth or one slightly dampened with water to clean the external case parts. Do not attempt to clean internally.

Electrical Maintenance

Refer to [“Review the Principles of Connector Care”](#) on page 3-5.

Analyzer Options, Accessories, and Upgrades Available

To see a list of the options, accessories, and upgrades available for the network analyzers, including ordering information, refer to the *Keysight PNA Family Microwave Network Analyzers Configuration Guide*, available online at <http://literature.cdn.keysight.com/litweb/pdf/5990-7745EN.pdf>.

Pulse I/O Adapter-N1966A

An adapter for connecting between the analyzer's rear-panel PULSE I/O connector and the coaxial inputs and outputs of external pulse generators and external pulse modulators. The adapter contains 11 SMB-male coaxial connectors and a mating connector for the rear-panel PULSE I/O connector.

This adapter can be ordered as model number N1966A.

Figure 2-1. Pulse I/O Adapter



N5242_001_201

Required Service Test Equipment

Equipment ^a	Critical Specifications	Recommended Model or Part Number	Alternate Model or Part Number	Use ^b
Test Instruments and Software				
Compression test set	None specified	U3070AK01	None	P
Dynamic accuracy test set	None specified	U3020AD01	None	P
Test software ^c	N/A	N7840A	None	P
Frequency counter	Freq: 10 MHz to 20 GHz Accuracy : ±0.5 ppm	53151A Opt 001	None	P, A,T
Signal generator	CW Freq: 1.185 GHz	N5181A,	E8257D, Option 520	P, A, T
Power meter	Accuracy: ±0.0068 dB	N1913A/14A	E4418A/B, E4419A/B ^d	P, A,T
Power sensor	Freq: 10 MHz to 4.2 GHz Range: -30 to +20 dBm	N8482A	8482A	P, A,T
Power sensor	Freq: 50 MHz to 40 or 50 GHz Range: -30 to +20 dBm	N8487A	8487A	P, A,T
Spectrum analyzer	Min Freq: 1 MHz Max Freq: > 4 GHz Resolution BW: 300 Hz	E444xA PSA series, N90xxA signal analyzer family	856xE	A,T
Digital voltmeter	Resolution: 10 mV	Any	Any	T
Printer	N/A	Any printer with Microsoft Windows XP or Windows 7 driver		--
Mouse	N/A	Any	Any	--
Keyboard	N/A	Any	Any	--

- a. Unless specified otherwise, equipment listed is required for all analyzer models.
b. P = Performance tests, A = Adjustments, T = Troubleshooting, V = System verification
c. The recommended model or part number for all equipment listed with a "P" in the Use column is required for proper operation of this test software.
d. If an accurate measurement of the dynamic accuracy specification is not required, the E4418A or E4419A can be used.

Equipment ^a	Critical Specifications	Recommended Model or Part Number	Alternate Model or Part Number	Use ^b
Calibration and Verification Kits				
2.4 mm calibration kit	--	85056A DC to 50 GHz	85056D DC to 50 GHz	P,T
2.4 mm verification kit	--	85057B 45 MHz to 50 GHz	None	V
Cables				
BNC cable (2 required)	50Ω, length ≥ 60 cm	8120-1839	None	A
2.4 mm RF cable (Qty 2)	50Ω, length ≥ 60 cm	85133C	85133E	P,A,V
GPIB cable	N/A	10833A/B/C/D	None	P,A
Adapters				
2.4 mm (f) to 2.4 mm (f)	Return Loss: ≥ 26 dB	11900B	85056-60007 ^c	P,A,T
2.4 mm (f) to type-N (m)	Return Loss: ≥ 28 dB	11903D	None	P,A,T
Attenuators				
2.4 mm (m,f), 10-dB fixed attenuator	Accuracy: ± 0.5 dB Freq: 10 MHz to 40 or 50 GHz	8490D Option 010	None	P
2.4 mm (m,f), 20-dB fixed attenuator	Accuracy: ± 0.5 dB Freq: 10 MHz to 40 or 50 GHz	8490D Option 020	None	P

- a. Unless specified otherwise, equipment listed is required for all analyzer models.
b. P = Performance tests, A = Adjustments, T = Troubleshooting, R = Repair, V = System verification
c. Included in the 85056A/D calibration kits.

Equipment ^a	Critical Specifications	Recommended Model or Part Number	Alternate Model Number	Use ^b
Tools				
T-8 TORX driver	0.6 N-m (5 in-lb) setting	N/A	N/A	R
T-10 TORX driver	0.5, 0.8, and 1.0 N-m (4, 7, and 9 in-lb) settings	N/A	N/A	T,R
T-20 TORX driver	2.4 N-m (21 in-lb) setting	N/A	N/A	T,R
1/4-inch and 5/16-inch open-end wrench	Thin profile	8710-0510	N/A	A,R
5/16-inch, open-end torque wrench	1.1 and 2.4 N-m (10 and 21 in-lb) settings (for semi-rigid cables)	N/A	N/A	T,R
1-inch, open-end torque wrench	8.1 N-m (72 in-lb) setting (for Port 1 and Port 2 connector nuts)	N/A	N/A	R
9-mm, socket or open-end wrench	2.38 N-m (21 in-lb) setting (for all front panel and most rear panel connector hex nuts)	N/A	N/A	R
20-mm, open-end torque wrench	0.9 N-m (8 in-lb) setting (for Port 1 and Port 2 measurement connections)	N/A	N/A	R
Static Safety Parts				
Adjustable antistatic wrist strap	N/A	9300-1367	None	P,A,T
Antistatic wrist strap grounding cord (5 foot)	N/A	9300-0980	None	P,A,T
Static control table mat and earth ground wire	N/A	9300-0797	None	P,A,T
Miscellaneous				
USB flash ROM drive	N/A	Any	None	P,A,R

- a. Unless specified otherwise, equipment listed is required for all analyzer models.
b. P = Performance tests, A = Adjustments, T = Troubleshooting, R = Repair, V = System verification

Keysight Support, Services, and Assistance

Information on the following topics is included in this section.

- [“Service and Support Options”](#)
- [“Contacting Keysight”](#)
- [“Shipping Your Analyzer to Keysight for Service or Repair”](#)

Service and Support Options

The analyzer’s standard warranty period is *three years from the time of initial delivery*. All repairs require the analyzer to be shipped to the nearest Keysight Technologies service center. Extended warranty periods can be purchased with the initial product purchase.

There are many other repair and calibration options available from the Keysight Technologies support organization. These options cover a range of service agreements with a variety of time frames. The following support products with their associated options are available for purchase with the initial product purchase.

- **R1280A Return to Keysight Warranty and Service Plan**
Options are available to extend the warranty period to five years.
- **R1282A Return to Keysight Calibration Plan**
The analyzer is delivered with a one-year calibration certificate. Options are available to have Keysight Technologies provide three or five year calibration coverage (perform the annual calibration two or four times). Options for basic calibration or ISO/IEC 17025 or ANSI/NCSL Z540.3–2006 standards compliant calibrations are available. After calibration, the analyzer will be returned with a calibration label, a calibration certificate, and the calibration data.
- **R1288A Return to Keysight On-Site Warranty and Service Plan**
Same as R1280A, but the service is provided at the customer site.
- **R1298A Return to Keysight On-Site Calibration Plan**
Same as R1282A, but the service is provided at the customer site.

For more information on these and other service, please visit

<https://service.keysight.com/infoline/public/default.aspx> or refer to [“Contacting Keysight” on page 2-8](#). If the warranty or calibration plan period has expired, these services are available on a per-incident basis. Visit this InfoLine web site or contact Keysight to obtain a quote.

Contacting Keysight

Assistance with test and measurements needs and information or finding a local Keysight office are available on the Web at:

<http://www.keysight.com/find/assist>

If you do not have access to the Internet, please contact your Keysight field engineer.

NOTE In any correspondence or telephone conversation, refer to the Keysight product by its model number and full serial number. With this information, the Keysight representative can determine whether your product is still within its warranty period.

Shipping Your Analyzer to Keysight for Service or Repair

IMPORTANT Keysight Technologies reserves the right to reformat or replace the internal solid state drive in your analyzer as part of its repair. This will erase all user information stored on the solid state drive. It is imperative, therefore, that you make a backup copy of your critical test data located on the analyzer's solid state drive before shipping it to Keysight for repair.

If you wish to send your network analyzer to Keysight Technologies for service or repair:

- Include a complete description of the service requested or of the failure and a description of any failed test and any error message.
- If alternate front handles and rack mount hardware have been installed, remove and retain them. The analyzer should be sent to Keysight in the same configuration as it was originally shipped.
- Reinstall front and rear impact covers.
- Ship the analyzer using the original or comparable antistatic packaging materials.
- Contact Keysight for instructions on where to ship your analyzer.

3 Tests and Adjustments

Information in This Chapter

This chapter contains procedures to help you check, verify, and adjust your PNA.

- The checks verify the operation of the assemblies in your analyzer.
- The verification compares the operation of your analyzer to a gold standard.
- The adjustments allow you to tune your analyzer for maximum response.

Conventions Used for Hardkeys, Softkeys, and Menu Items

The following conventions are used in this document:

Hardkey

This represents a “hardkey”, a key that is physically located on the instrument.

Softkey

This represents a “softkey”, a key whose label is determined by the instrument firmware.

Menu Item

This represents an item in a drop-down or pop-up menu.

Chapter Three at-a-Glance

Section Title	Summary of Content	Start Page
Before You Begin	Items to consider or procedures to perform before testing is begun: <ul style="list-style-type: none"> • Verify the Operating Environment • Protect Against Electrostatic Discharge (ESD) • Allow the Analyzer to Warm Up • Review the Principles of Connector Care 	Page 3-4
About System Verification and Performance Tests	Descriptions of: <ul style="list-style-type: none"> • System Specifications • Instrument Specifications • System Verification Procedure • Performance Tests • Certificate of Calibration 	Page 3-6
ANSI/NCSL Z540.3–2006 and ISO/IEC 17025 Verification	The ANSI/NCSL Z540.3–2006 and ISO/IEC 17025 process of verifying your analyzer.	Page 3-8
Non-Standards Compliant Verification	The Non-Standards Compliant process of verifying your analyzer.	Page 3-9

Section Title	Summary of Content	Start Page
<p>Preliminary Checks</p>	<p>Performing the operator’s check. Checking your test cables. <i>Perform these checks before performing system verification.</i></p>	<p>Page 3-10</p>
<p>System Verification</p>	<p>What the system verification does. How to perform the verification test. How to interpret the results.</p>	<p>Page 3-19</p>
<p>Performance Tests^a</p>	<p>A brief summary of each performance test:</p> <ul style="list-style-type: none"> • Source Maximum Power Output Test • Source Power Linearity Test • Frequency Accuracy Test • Trace Noise Test • Receiver Compression Test • Noise Floor Test • Calibration Coefficients Test • Dynamic Accuracy Test 	<p>Page 3-28</p>
<p>Adjustments^b</p>	<p>Setups and procedures for adjusting your analyzer:</p> <ul style="list-style-type: none"> • 10 MHz Frequency Reference Adjustment • IF Gain Adjustment • Synthesizer Bandwidth Adjustment • Source Adjustment • Receiver Adjustment • Receiver Characterization • EE Default Adjustment 	<p>Page 3-39</p>

a. These performance tests are included in the analyzer’s firmware for Options 897 and 898.

b. These adjustments are included in the analyzer’s firmware on all models and options.

Before You Begin

Before checking, verifying, or adjusting the analyzer, refer to the following paragraphs to:

- make sure the operating environment is within its requirements
- make sure that proper electrostatic discharge (ESD) protection is provided
- make sure the analyzer has warmed up properly to achieve system stability
- review the principles of connector care

IMPORTANT Keysight personnel: see [Figure 1-1 on page 1-5](#) to review where the calibration stickers should be placed on the PNA.

Verify the Operating Environment

Due to their operating specifications, the verification and calibration kit devices determine the limits of your operating environment conditions. Open the calibration and verification kits and place all the devices on top of the foam inserts so they will reach room temperature. As the device dimensions change with temperature, their electrical characteristics change as well.

It is necessary to keep the environmental levels within the following limits:

- Temperature: $+23\text{ }^{\circ}\text{C} \pm 3\text{ }^{\circ}\text{C}$ (Error-corrected temperature range)

Once the measurement calibration has been done, the ambient temperature must be maintained to within $\pm 1\text{ }^{\circ}\text{C}$ of the calibration temperature.

- Humidity: 0% to 95% at 40 °C maximum, non-condensing
- Altitude: 0 to 4,600 meters ($\approx 15,000$ feet.)

Protect Against Electrostatic Discharge (ESD)

This is important. If not properly protected against, electrostatic discharge can seriously damage your analyzer, resulting in costly repair.

CAUTION To reduce the chance of electrostatic discharge, follow all of the recommendations outlined in ["Electrostatic Discharge Protection" on page 1-6](#), for all of the procedures in this chapter.

Allow the Analyzer to Warm Up

NOTE To achieve the maximum system stability, allow the analyzer to warm up for at least 90 minutes.

Review the Principles of Connector Care

Proper connector care and connection techniques are critical for accurate and repeatable measurements. Refer to [Table 3-1](#) for tips on connector care.

Prior to making connections to your analyzer, carefully review the information about inspecting, cleaning, and gaging connectors. Refer to the calibration kit documentation for detailed connector care information.

For course numbers about additional connector care instruction, contact Keysight Technologies. Refer to [“Contacting Keysight” on page 2-8](#).

Table 3-1 Connector Care Quick Reference Guide

Handling and Storage	
Do <ul style="list-style-type: none"> • Keep connectors clean • Extend sleeve or connector nut • Use plastic end-caps during storage 	Do Not <ul style="list-style-type: none"> • Touch mating-plane surfaces • Set connectors contact-end down • Store connectors or adapters loose
Visual Inspection	
Do <ul style="list-style-type: none"> • Inspect all connectors carefully • Look for metal particles, scratches, and dents 	Do Not <ul style="list-style-type: none"> • Use a damaged connector - ever
Connector Cleaning	
Do <ul style="list-style-type: none"> • Try compressed air first • Use isopropyl alcohol^a • Clean connector threads 	Do Not <ul style="list-style-type: none"> • Use any abrasives • Get liquid into plastic support beads
Gaging Connectors	
Do <ul style="list-style-type: none"> • Clean and zero the gage before use • Use the correct gage type • Use correct end of calibration block • Gage all connectors before first use 	Do Not <ul style="list-style-type: none"> • Use an out-of-specification connector
Making Connections	
Do <ul style="list-style-type: none"> • Align connectors carefully • Make preliminary connection contact lightly • Turn only the connector nut • Use a torque wrench for final connection 	Do Not <ul style="list-style-type: none"> • Apply bending force to connection • Over tighten preliminary connection • Twist or screw any connection • Tighten past torque wrench “break” point

- a. Cleaning connectors with alcohol shall only be done with the instrument’s power cord removed, and in a well-ventilated area. Allow all residual alcohol moisture to evaporate, and the fumes to dissipate prior to energizing the instrument.

About System Verification and Performance Tests

The performance of the network analyzer is specified in two ways: system specifications, and instrument specifications. It is the end user's responsibility to determine which set of specifications is applicable to their use of the PNA.

A network analyzer measurement "system" includes the analyzer, calibration kit, test cables, and any necessary adapters. **The system verification software in the PNA is used to verify the system's conformance to the "system" specifications.** A "pass" result demonstrates that the analyzer, test cables, and adapters, perform correctly as a system. It DOES NOT demonstrate that any one component performs according to its individual specifications. A change to any part of this measurement system requires a re-verification of the system.

Instrument specifications specify the network analyzer's uncorrected measurement port characteristics and its output and input behavior. **The PNA performance tests are used to verify the analyzer's conformance to "instrument" specifications.**

System Specifications

System specifications specify warranted performance of the measurement system when making error-corrected measurements using the same calibration kit and test cables used during the system verification routine. System specifications are applicable only when the measurement system is used to make error-corrected measurements.

The analyzer's system specifications are described in the Data Sheet and Technical Specifications documents, available online at: <http://literature.cdn.keysight.com/litweb/pdf/N5221-90002.pdf> and <http://literature.cdn.keysight.com/litweb/pdf/N5221-90001.pdf>.

System specifications are expressed in two ways:

- residual errors of the measurement system shown as tabular specification values
- graphs of measurement uncertainty versus reflection and transmission coefficients

System specifications are verified in one of the following ways:

- Complete the system verification procedure using a certified verification kit and certified calibration kit that will be used for future measurements, or
- Complete all of the performance tests using a certified calibration kit that will be used for future measurements. This alternative verifies both the system specifications and the instrument specifications for the analyzer.

Instrument Specifications

The analyzer's instrument specifications are described in the Data Sheet and Technical Specifications documents, available online at: <http://literature.cdn.keysight.com/litweb/pdf/N5221-90002.pdf> and <http://literature.cdn.keysight.com/litweb/pdf/N5221-90001.pdf>.

These specifications apply when the analyzer is used to make either raw or error-corrected measurements.

System Verification Procedure

The system verification procedure tests the network analyzer measurement "system", as defined previously,

against the system specifications. If confirmation is successful, the measurement system is capable of making measurements to the accuracy specified by the graphs of measurement uncertainty.

The procedure consists of calibrating the analyzer with a calibration kit, measuring a set of characterized devices, and comparing the resultant measured data to the data and uncertainty limits supplied with the verification kit. The device data provided with the verification kit has a traceable path to NIST. The total measurement uncertainty limits for the performance verification are the sum of the factory measurement uncertainties and the uncertainties associated with measuring the same devices on the system being verified. The difference between the factory-measured data and the verification-measured data must fall within the total uncertainty limits at all frequencies for the total system uncertainty test to pass.

NOTE Calibration kits are different from verification kits. Calibration kits are used to determine the systematic errors of a network analyzer measurement system. Verification kits are used to confirm system specifications and are not used to generate error correction.

Performance Tests

Performance tests are used to confirm analyzer performance against the “instrument” specifications. If confirmation is successful, the PNA meets the instrument specifications.

Performance tests are contained in the analyzer’s firmware with Options 897 or 898 and are described at “[Performance Tests](#)” on page 3-28.

An illustrated outline of the performance verification procedure:

- for ANSI/NCSS Z540.3-2006 and ISO/IEC 17025 verification, is shown in [Figure 3-1 on page 3-8](#).
- for non-standards verification, is shown in [Figure 3-2 on page 3-9](#).

Certificate of Calibration

Keysight Technologies will issue a certificate of calibration upon successful completion of system verification or completion of the performance tests. The certificate of calibration will apply to the “system” (analyzer, calibration kit, test cables, and any necessary adapters) if the system verification procedure is used to confirm the system specifications. If the performance tests are used to confirm instrument specifications, the certificate of calibration will apply to the PNA as an independent instrument. The equipment and measurement standards used for the tests must be certified and must be traceable to recognized standards.

NOTE If you have a measurement application that does not use all of the measurement capabilities of the analyzer, you may ask your local Keysight Technologies service office to verify only a subset of the specifications. However, this “limited calibration” creates the possibility of making inaccurate measurements if you then use the analyzer in an application requiring additional capabilities.

ANSI/NCSL Z540.3–2006 and ISO/IEC 17025 Verification

To meet the criteria for ANSI/NCSL Z540.3–2006 and ISO/IEC 17025, perform the preliminary checks and all performance tests *without stopping to repair or adjust*¹. Refer to **Figure 3-1** for test flow. Print data at the completion of all the tests, even if you are aware that the analyzer did not pass. If there is a failure, complete the verification before you troubleshoot, repair, and adjust. After the failure has been corrected, repeat the entire set of performance tests and generate a new set of data.

Figure 3-1 ANSI/NCSL Z540.3–2006 and ISO/IEC 17025 Verification Flowchart

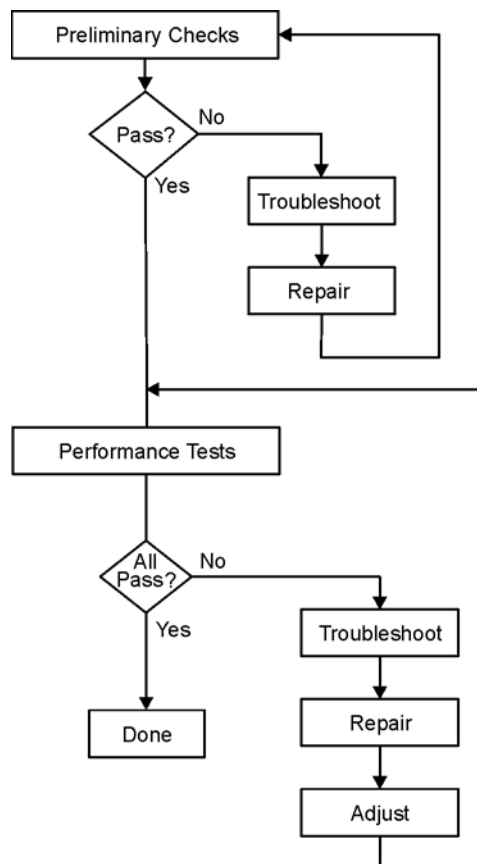

sc870b

1. Stop only in case of a catastrophic failure or cable connector damage

Non-Standards Compliant Verification

To meet the criteria for non-standards compliant verification, perform the preliminary checks and the performance tests while *stopping to troubleshoot*. Refer to [Figure 3-2](#) for test flow. Troubleshoot and repair the first problem encountered without continuing to other tests. After you troubleshoot, repair, and adjust, repeat the *last failed* portion and generate a new set of data.

Figure 3-2 Non-Standards Compliant Verification Flowchart

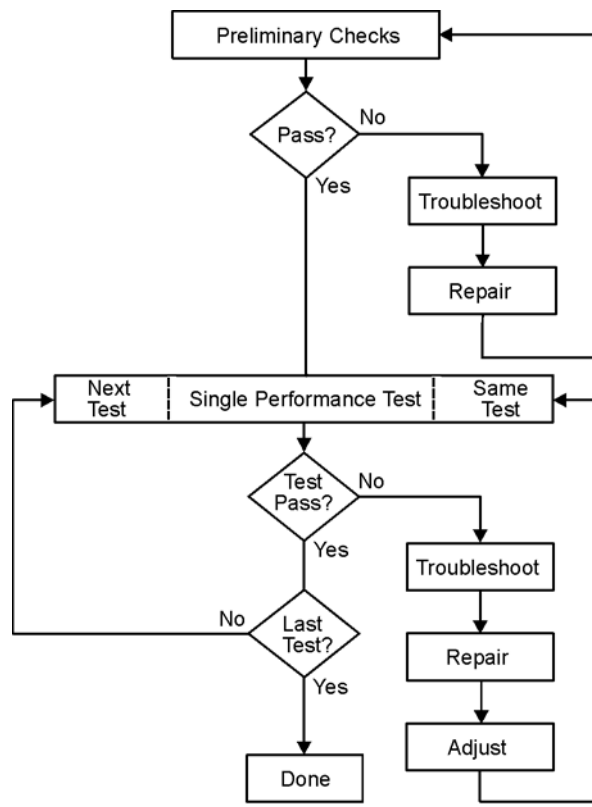

sc869b

Preliminary Checks

Preliminary checks include the following:

- “The Operator’s Check” on page 3-10

The operator’s check tests the network analyzer’s basic functionality of the source, switch, and receivers.

- “The Test Port Cable Checks” on page 3-12

The test port cable checks are not required, but are recommended to verify the performance of the test port cables before performing the verification test.

The Operator’s Check

NOTE To achieve the maximum system stability, allow the analyzer to warm up for at least 90 minutes before performing the Operator’s Check.

The operator’s check is a software driven test that checks the basic operation of the assemblies in all of the measurement port signal paths. By performing the operator’s check, the following are determined:

- attenuation ranges of all installed attenuators
- calibration of the receivers
- frequency response of the receivers
- phase lock and leveling
- basic functional test of noise floor and trace noise

Accessories Used in the Operator’s Check

Equipment Type	Part Number
Female short, 2.4 mm	(any short from the 85056B/D calibration kits)
Female open, 2.4 mm	(any open from the 85056B/D calibration kits)

Performing the Operator’s Check

1. Press UTILITY **System**, then **Service**, then **Operator’s Check**.
2. In the **PNA Operator’s Check** dialog box (refer to **Figure 3-3**), under **Configure**, select either **Prompt for attachment of Short/Open**, to pause at each step in the process to allow moving the short/open to the appropriate port, or **Shorts/Opens are attached to ALL ports**, to run through the test without stopping. Shorts and opens can be mixed on the test ports.
3. Click **Begin**.
4. If shorts and opens are not connected to all ports, you will be prompted to connect them as they are needed.
5. The result of the operator’s check will be shown as a PASS or FAIL next to each test (refer to **Figure 3-3**).

The PNA Operator's Check dialog box will look different for different PNA model numbers and installed options. Some of the tests are performed only if the appropriate options are installed in the PNA.

Figure 3-3 Operator's Check Dialog Box

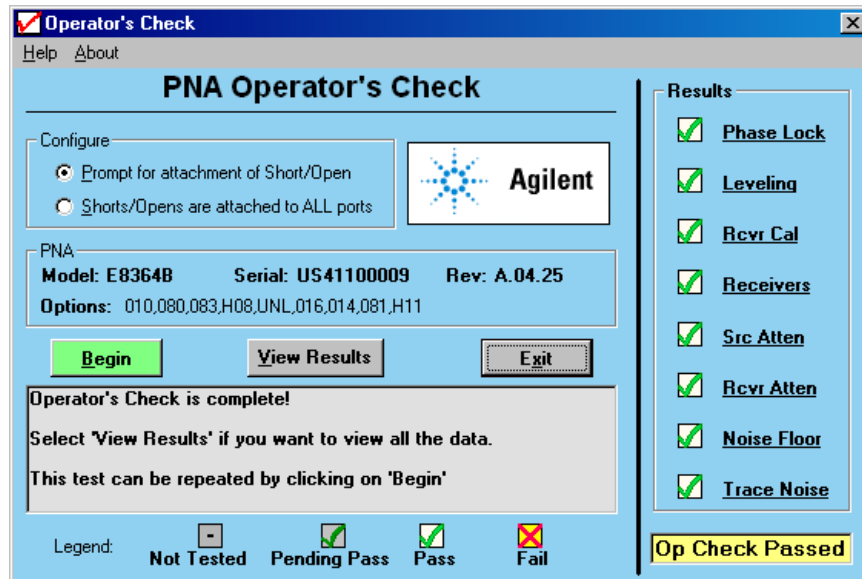
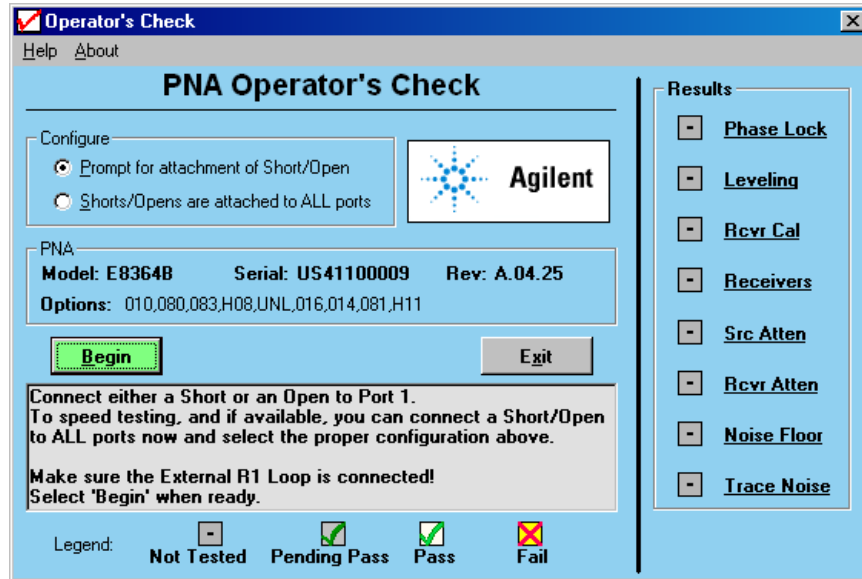

If the Operator's Check Fails

1. Clean the test ports, shorts, and adapters. Torque to specification. Repeat the check.
2. If the check still fails, suspect a faulty component. Refer to ["Measurement System Troubleshooting"](#) on [page 4-23](#) to begin troubleshooting to determine the faulty component.

The Test Port Cable Checks

A faulty test port cable can cause a failure in the verification test. The following checks are not required, but are recommended to verify the performance of the test port cable.

- “Cable Return Loss Check” on page 3-13
- “Cable Insertion Loss Check” on page 3-14
- “Cable Magnitude and Phase Stability Check” on page 3-15
- “Cable Connector Repeatability Check” on page 3-17

Accessories Used in the Test Port Cable Checks

Equipment Type	Model or Part Number	Alternate Model or Part Number
Calibration kit, 2.4 mm	85056A	85056D
Test cable, 2.4 mm (f) to 2.4 mm (f)	85133C	85133E

Cable Return Loss Check

1. Press UTILITY **Preset**.
2. Perform a one-port calibration on Port 1, **1-Port Reflection**. Refer to the embedded help in the analyzer if necessary.
3. Connect the test port cable to Port 1. Connect a broadband load to the other end of the cable. Tighten to the specified torque for the connector type.

The analyzer now displays the return loss of the cable.

4. Press MARKER/ANALYSIS **Search**, then **Search**. In the **Marker Search** dialog box, in the **Search Type** box, make sure **Maximum** is selected. Click **Execute**, and then click **OK**.
5. The marker annotation on the screen indicates the worst case return loss. Refer to the cable manual to see if it meets the return loss specification. For an example of a typical return loss measurement, see [Figure 3-4](#).

Figure 3-4 Typical Cable Return Loss Response

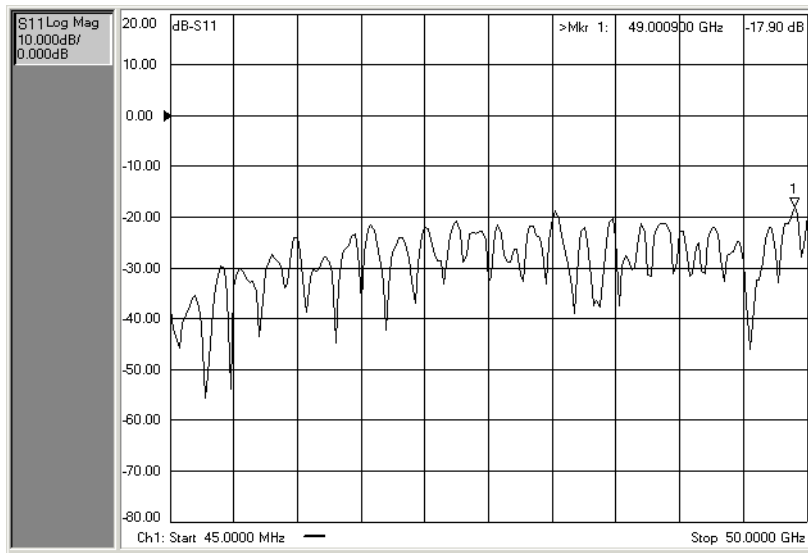

If the Cable Return Loss Check Fails

1. Clean the cable and devices and torque to specification. Repeat the check.
2. If the check still fails, the cable should be repaired or replaced.

Cable Insertion Loss Check

1. With the test port cable still connected to Port 1, connect a short to the other end of the cable.
2. Press MARKER/ANALYSIS , then . In the **Marker Search** dialog box, in the **Search Type** box, select **Minimum**. Click **Execute**, and then click **OK**.
3. The displayed response is twice the actual loss. To get the actual worst case insertion loss, divide the value at the marker annotation by two. Refer to the cable manual to see if it meets the insertion loss specification. For an example of a typical insertion loss measurement, see [Figure 3-5](#).

Figure 3-5 Typical Cable Insertion Loss Response

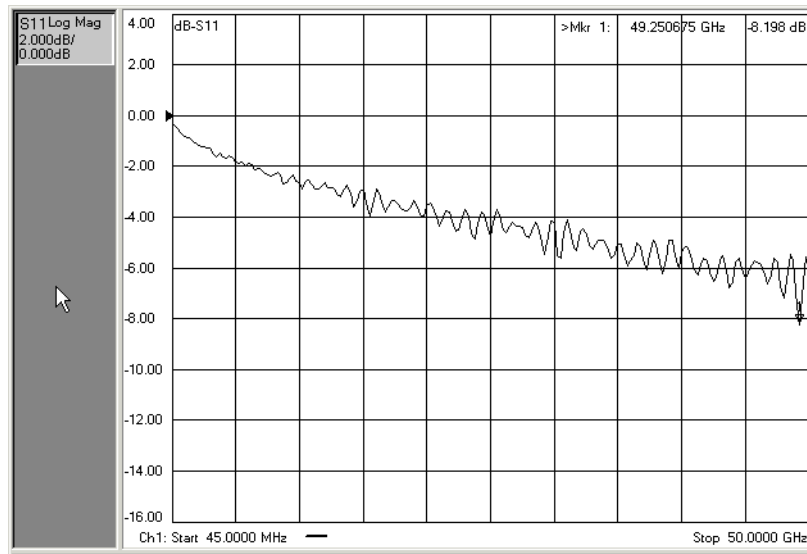

If the Cable Insertion Loss Check Fails

1. Clean the cable and devices and torque to specification. Repeat the check.
2. If the check still fails, the cable should be repaired or replaced.

Cable Magnitude and Phase Stability Check

1. With the test port cable still connected to Port 1, connect a short to the other end of the cable.
2. Press UTILITY **Preset**.
3. Press TRACE/CHANNEL **Traces**, then **New Trace...**. In the **New Trace** dialog box, click the **S11** box, and then click **OK**.
4. Press RESPONSE **Format**, then **Phase**, then ENTRY **Enter**.
5. Press RESPONSE **Avg**. Verify that **Average ON/off** is **ON**. If not, press the **Average on/OFF** softkey to toggle it **ON**.

The **Averaging Factor** box will appear directly above the display. In the **Averaging Factor** box, type **50** or click the arrows to select **50**, and then press ENTRY **Enter**.

6. To provide a good reference, hold the test cable in a straight line perpendicular to the front panel of the network analyzer.
7. Press RESPONSE **Avg**, then **Averaging Restart**.
8. Wait for the analyzer to average the measurement 50 times (approximately two seconds).
9. To normalize the data trace: press MARKER/ANALYSIS **Memory**, then **Data Trace**, then **Data Math**, then **Data/Memory**, then ENTRY **Enter**.
10. Slowly make a 180 degree bend in the middle of the cable and hold it in that position.
11. For each trace: press RESPONSE **Scale**, then **Scale**.

The **Scale Per Division** box will appear directly above the display. Set the **Scale Per Division** for optimum viewing as shown in [Figure 3-6](#).

12. Place a marker on the largest deflection that goes above the reference line and is within the cable's specified frequency range. For a typical response of cable magnitude and phase stability, see [Figure 3-6](#).
13. Place a marker on the largest deflection that goes below the reference line and is within the cable's specified frequency range.

In this S_{11} measurement, the displayed trace results from energy being propagated down the cable and reflected back from the short. Therefore, the measured deflection value must be divided in half to reach the correct value.

Figure 3-6 Typical Cable Magnitude and Phase Stability Response

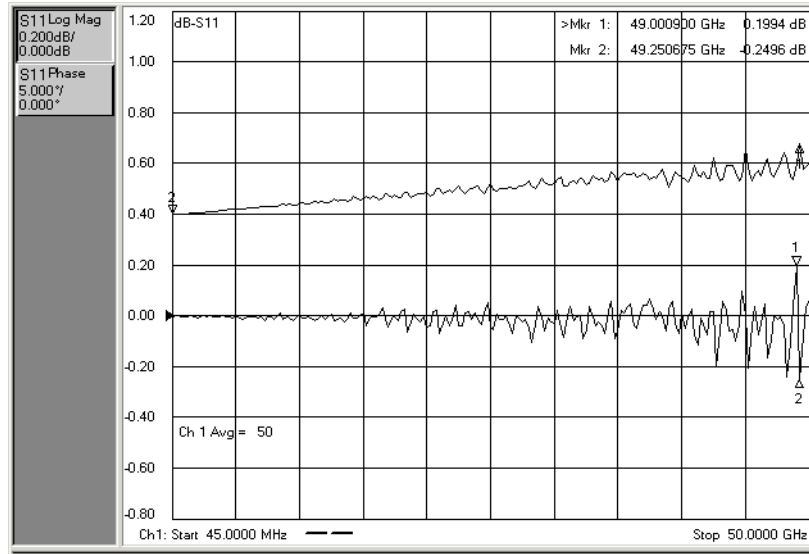

If the Cable Magnitude and Phase Stability Check Fails

1. Clean the cable and devices and torque to specification. Repeat the check.
2. If the check still fails, the cable should be repaired or replaced.

Cable Connector Repeatability Check

NOTE The connector repeatability measurement should be done at the test port as well as at the end of the test port cable.

1. With the test port cable still connected to Port 1, connect a broadband load to the other end of the cable.
2. Press UTILITY **Preset**.
3. Press RESPONSE **Avg**. Verify that **Average ON/off** is **ON**. If not, press the **Average on/OFF** softkey to toggle it **ON**.
The **Averaging Factor** box will appear directly above the display. In the **Averaging Factor** box, type **100** or click the arrows to select **100**, and then press ENTRY **Enter**.
4. Wait for the analyzer to average the measurement 100 times (approximately five seconds).
5. To normalize the data trace: press MARKER/ANALYSIS **Memory**, then **Data Trace**, then **Data Math**, then **Data/Memory**, then ENTRY **Enter**.
6. To adjust the display scale:
 - a. Press RESPONSE **Scale**, then **Scale**.
The **Scale Per Division** box will appear directly above the display. Set the **Scale Per Division** for **0.5 dB**. Press ENTRY **Enter**.
 - b. Press **Reference Level**.
The **Reference Level** box will appear directly above the display. Set the **Reference Level** for **0 dB**. Press ENTRY **Enter**.
7. Disconnect and then reconnect the cable to the test port. Tighten the connection to the specified torque for the connector type.
8. Press RESPONSE **Avg**, then **Averaging Restart**.
9. Look at the trace for spikes or modes.
10. To re-normalize the data trace of the reconnected cable: press MARKER/ANALYSIS **Memory**, then **Data->Memory**, then ENTRY **Enter**.
11. Repeat steps 7 through 9 at least three times to look for modes. Modes appear when a harmonic of the source fundamental frequency is able to propagate through the cable or connector. It is helpful to print a plot of the trace each time to compare several connections. If any mode appears each time the cable is connected and reconnected, measurement integrity will be affected.
For a typical response of cable connector repeatability, see [Figure 3-7](#).
12. For the Port 2, 3, and 4 Check, connect the cable (with the load attached) to the respective port and repeat steps 2 through 11.

Figure 3-7 Typical Cable Connector Repeatability Response

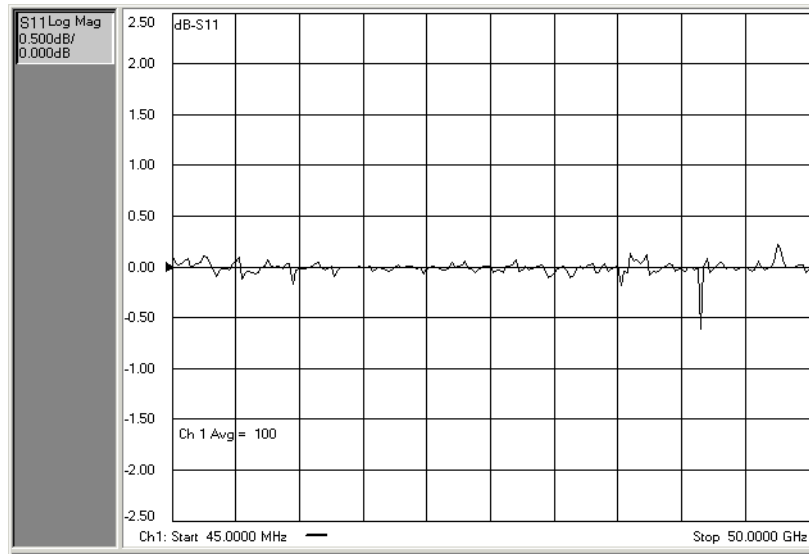

If the Cable Connector Repeatability Check Fails

1. Clean the cable and devices, and torque to specification. Repeat the check.
2. If the check still fails, the cable should be repaired or replaced.

System Verification

System verification is used to verify system-level, error-corrected uncertainty limits for network analyzer measurements. The verification procedure is automated and is contained in the firmware of the analyzer.

The device data provided with the verification kit has a traceable path to a national standard. The difference between the supplied traceable data and the measured data must fall within the total uncertainty limits at all frequencies for the system verification to pass.

The total measurement uncertainty limits for the system verification are the sum of the factory measurement uncertainties for the verification devices and the uncertainties associated with the system being verified. You can determine your system measurement uncertainty limits by referring to the analyzer embedded on-line help.

IMPORTANT Passing this system verification does not guarantee that the analyzer meets all of its performance specifications. However, it does show that the network analyzer being verified measures the same devices with the same results as a factory system which has had all of its specifications verified and its total measurement uncertainty minimized.

What the System Verification Verifies

The system verification procedure verifies proper operation of the:

- network analyzer
- calibration kit
- test port cables

together as a “system”. It DOES NOT verify that any of these components pass their specifications independently. The user is responsible for independently calibrating and verifying the proper operation of the calibration kit and test port cables prior to performing the system verification.

NOTE Additional equipment or accessories used with the above system are not verified by system verification.

Measurement Uncertainty

Measurement uncertainty is defined as the sum of:

- the residual systematic (repeatable) errors, and
- the random (non-repeatable) errors

in the measurement system after calibration.

The systematic errors are:

- directivity,
- source match,
- load match,
- reflection and transmission frequency tracking, and
- isolation (crosstalk).

The random errors include:

- noise,
- drift,
- connector repeatability, and
- test cable stability.

A complete description of system errors and how they affect measurements is provided in the analyzer's on-line embedded help.

Any measurement result is the vector sum of the actual test device response plus all error terms. The precise effect of each error term depends on its magnitude and phase relationship to the actual test device response. When the phase of an error response is not known, phase is assumed to be worst-case (-180° to $+180^\circ$). Random errors such as noise and connector repeatability are generally combined in a root-sum-of-the-squares (RSS) manner.

Measurement Traceability

To establish a measurement traceability path to a national standard for a network analyzer system, the overall system performance is verified through the measurement of devices that have a traceable path. This is accomplished by measuring the devices in an Keysight verification kit.

The measurement of the devices in the verification kit has a traceable path because the factory system that measured the devices is calibrated and verified by measuring standards that have a traceable path to the National Institute of Standards and Technology (NIST) (see Figure 3-8). This chain of measurements defines how the verification process brings traceability to the network analyzer system.

Figure 3-8 NIST Traceability Path for Calibration and Verification Standard

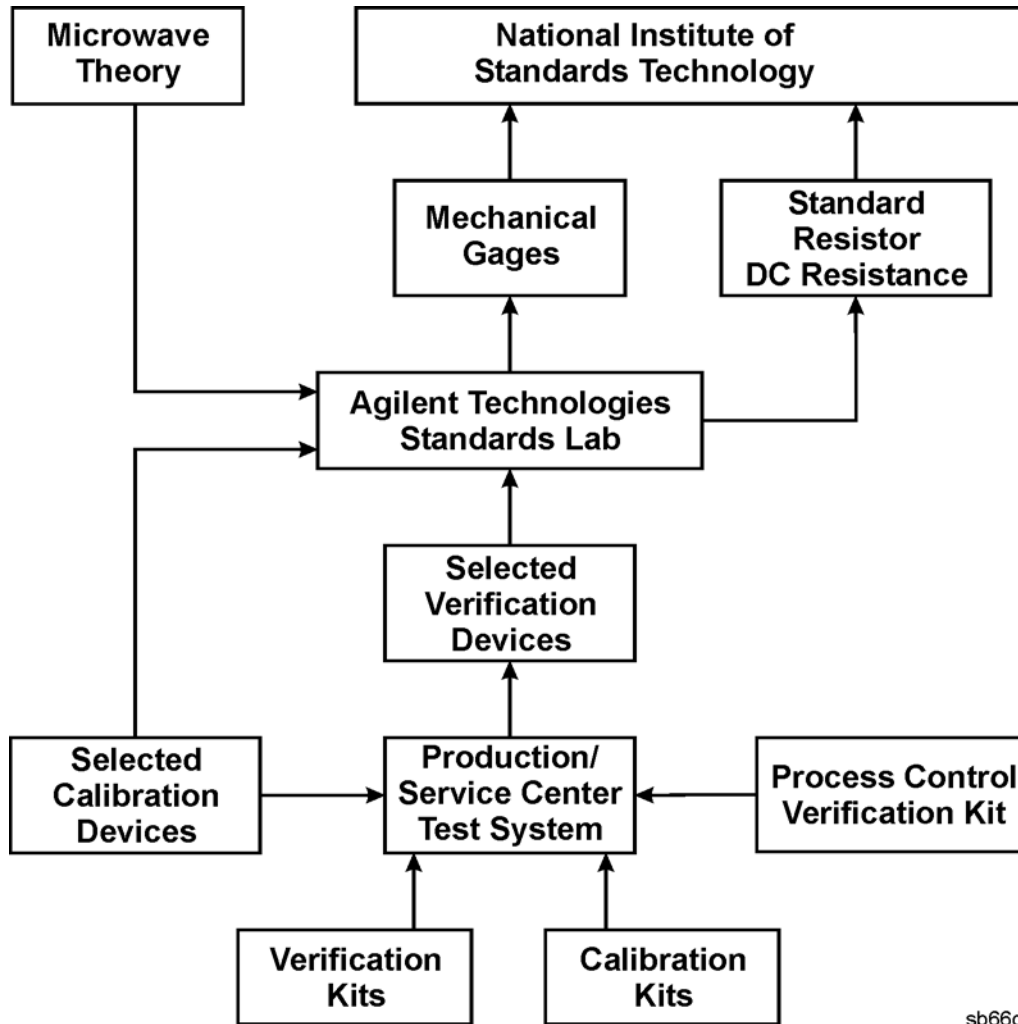

sb66d

Performing System Verification

The following verification procedure is automated by the analyzer firmware. The process for the verification is:

- connect cables to the analyzer test ports
- perform a calibration or recall a recent calibration
- run the system verification program for the verification devices

Each time through the verification process, you are prompted to make necessary connections and perform or recall a calibration as part of performing the verification. If you select to perform a calibration, you are guided through the calibration procedure. This part of the process can be eliminated if you choose to load an existing recent calibration that was created by the verification process. If necessary, refer to the analyzer's on-line embedded help for information on storing and recalling calibrations.

For each verification device, the analyzer reads a file from the verification disk and sequentially measures the magnitude and phase for all four S-parameters.

IMPORTANT For system verification to perform correctly, it is **NECESSARY** that the verification devices be measured with their female connectors connected to port 1 or 3 and their male connectors connected to port 2 or 4.

NOTE Although the performance for all S-parameters are measured, the S_{11} and S_{22} phase uncertainties for the attenuators and airlines are less important for verifying system performance. Therefore, the limit lines will not appear on the printout.

Equipment Used in the System Verification Procedure

Equipment Type	2.4 mm	3.5 mm	Type-N
Calibration kit	85056B/D N4692A ECal	85052B, C, D N4691 ECal	85054B/D N4690A E-cal
Verification kit	85057B	85053B	85055A
Cables	85133C/D/E/F	Single cable: 85134E Cable pair: 85134F	Single cable: 85135E (2.4 mm NMD to 7 mm) Cable pair: 85135F (2.4 mm NMD to 7 mm)
Adapters	None required	None required	With single cable: an 85130E adapter and a 7mm to Type-N adapter from the 85054B calibration kit. With cable pair: Two 7mm to Type-N adapters from the 85054B calibration kit.

Cable Substitution

The test port cables specified for the network analyzer system have been characterized for connector repeatability, magnitude and phase stability with flexing, return loss, insertion loss, and aging rate. Since test port cable performance is a significant contributor to the system performance, cables of lower performance will increase the uncertainty of your measurement. Refer to the plots in the cable tests (earlier in this chapter) that show the performance of good cables. It is highly recommended that the test port cables be regularly tested.

If the system verification is performed with a non-Keysight cable, ensure that the cable meets or exceeds the specifications for the test cable specified in the previous table, **“Equipment Used in the System Verification Procedure.”** Refer to the cable’s user’s guide for specifications.

Kit Substitution

Non-Keysight calibration kits and verification kits are not recommended nor supported.

System Verification Procedure

1. If you desire printed test outputs, connect a printer to the analyzer. For the printer, ensure that the correct driver is loaded and the printer is defined as the default printer. Refer to the embedded help in the analyzer for printer setup. Let the analyzer warm up for at least 90 minutes.
2. Insert the verification kit disk into the analyzer disk drive.
3. Press UTILITY **System**, then **Service**, then **System Verification**. The **System Verification** dialog box is displayed; refer to **Figure 3-9**.

Figure 3-9 System Verification Dialog Box

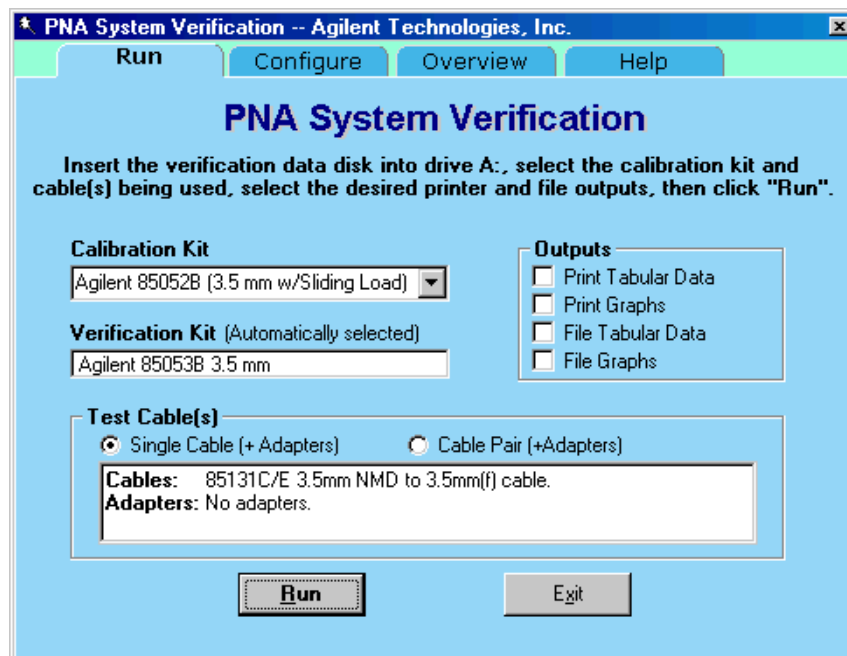

4. In the **Calibration Kit** box, select the calibration kit or electronic calibration module (ECal) that is being used by clicking on it. The corresponding verification kit to use is selected for you and displayed in the

Verification Kit box. Refer to [Figure 3-9](#).

5. Under **Printer Output**, click one of the following options. Refer to [Figure 3-9](#).
 - **Print Tabular Data**: Prints the verification data in tabular form which includes measured data and uncertainty limits. For an example, refer to [Figure 3-11 on page 3-26](#).
 - **Print Graphs**: Prints the verification data in graphical form. The graphical form includes the measured data trace, factory supplied data trace, and uncertainty limits. For an example, refer to [Figure 3-12 on page 3-27](#).
 - **File Tabular Data**: Writes the tabular data to a text file in the Windows XP directory C:\Program Files\Keysight\Network Analyzer\Documents\ or in the Windows 7 directory C:\Users\Public\Public Documents\Network Analyzer\SysVer\.
 - **File Graphs**: Saves a screen image in PNG format in the Windows XP directory C:\Program Files\Keysight\Network Analyzer\Documents\ or in the Windows 7 directory C:\Users\Public\Public Documents\Network Analyzer\SysVer\.

NOTE For printed output, it is assumed that the printer has been tested and the Windows driver is installed for the printer that is being used. The system verification test prints to the printer that has been designated as the default printer. (On the Windows Desktop display, click on **My Computer, Control Panel**, and then **Printers** to verify the printer setup.)

To modify the number of ports to be verified or to change the number of devices to measure, click on the **Configure** tab and make the desired selections.

6. Click **Run**.
7. Follow the instructions on the analyzer for performing a full calibration or recalling an existing recent calibration.
8. Follow the instructions on the analyzer for performing the system verification; inserting the verification devices as prompted.

If the System Fails the Verification Test

IMPORTANT Inspect all connections. *Do not* remove the cable from the analyzer test port. This *will invalidate* the calibration that you performed earlier.

1. Disconnect and clean the device that failed the verification test.
2. Reconnect the device making sure that all connections are torqued to the proper specifications.
3. Measure the device again.
4. If the analyzer still fails the test, check the measurement calibration by viewing the error terms as described in [“Accessing Error Terms” on page 8-8](#).
5. Refer to [Figure 3-10](#) for additional troubleshooting steps.

Figure 3-10 System Verification Failure Flowchart

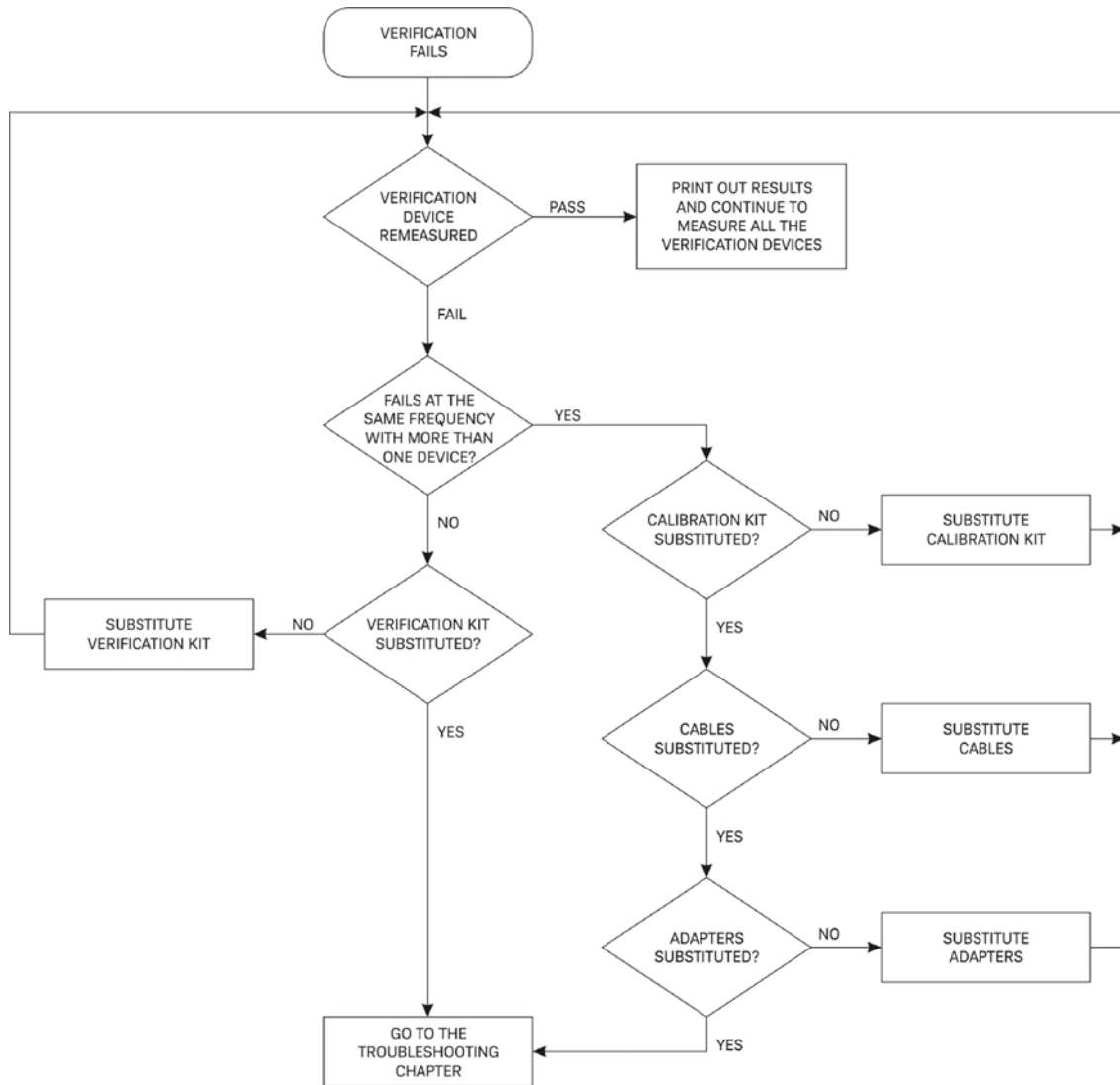

sb69d

Interpreting the Verification Results

Figure 3-11 shows an example of typical verification results with **Print Tabular Data** selected in the **Printer Output** area of the **System Verification** dialog box.

At the top of the printed output is the name of the device, the serial number of the device, and the date tested.

Each S-parameter measurement result is printed with frequency tested, lower and upper limit lines, the measured data, and the result of the test.

Figure 3-11 Example of Printed Tabular Verification Results

PNA System Verification								
Model: N5230A 225		Ser. Num.: US43390055		Test Time: 12/8/2004 2:08:35 PM				
Device: 20 dB Attenuator, Serial #02743				S11 Results		PASS		
Freq [GHz]	S11 MAGNITUDE (lin)				S11 PHASE (deg)			
	Lower Limit (lin)	Meas'd Data (lin)	Upper Limit (lin)	Total Uncert +/-	Lower Limit (deg)	Meas'd Data (deg)	Upper Limit (deg)	Total Uncert +/-
0.045	0.0067	0.0045	0.0113	0.0090	n/a	177.46	n/a	n/a
0.50	0.0067	0.0046	0.0114	0.0091	n/a	155.77	n/a	n/a
1.00	0.0057	0.0047	0.0125	0.0091	n/a	127.90	n/a	n/a
1.50	0.0043	0.0050	0.0139	0.0091	n/a	99.52	n/a	n/a
2.00	0.0034	0.0055	0.0148	0.0091	n/a	72.43	n/a	n/a
2.50	0.0076	0.0061	0.0208	0.0142	n/a	46.58	n/a	n/a
3.00	0.0068	0.0067	0.0216	0.0142	n/a	21.57	n/a	n/a
3.50	0.0066	0.0075	0.0227	0.0146	n/a	-0.45	n/a	n/a
4.00	0.0060	0.0086	0.0233	0.0146	n/a	-20.94	n/a	n/a
4.50	0.0056	0.0098	0.0237	0.0147	n/a	-39.48	n/a	n/a
5.00	0.0053	0.0109	0.0241	0.0147	n/a	-56.13	n/a	n/a
5.50	0.0051	0.0118	0.0242	0.0147	n/a	-71.75	n/a	n/a
6.00	0.0050	0.0125	0.0244	0.0147	n/a	-86.47	n/a	n/a
6.50	0.0049	0.0131	0.0244	0.0147	n/a	-100.81	n/a	n/a
7.00	0.0057	0.0136	0.0236	0.0147	n/a	-113.94	n/a	n/a
7.50	0.0061	0.0138	0.0232	0.0147	n/a	-125.68	n/a	n/a
8.00	0.0059	0.0138	0.0234	0.0147	n/a	-135.63	n/a	n/a
8.50	0.0110	0.0136	0.0287	0.0198	n/a	-144.53	n/a	n/a
9.00	0.0107	0.0133	0.0290	0.0199	n/a	-152.31	n/a	n/a
9.50	0.0101	0.0130	0.0297	0.0199	n/a	-159.32	n/a	n/a
10.00	0.0092	0.0129	0.0305	0.0199	n/a	-165.12	n/a	n/a
10.50	0.0080	0.0129	0.0317	0.0199	n/a	-169.47	n/a	n/a
11.00	0.0066	0.0130	0.0332	0.0199	n/a	-172.95	n/a	n/a
11.50	0.0051	0.0135	0.0347	0.0199	n/a	-176.46	n/a	n/a
12.00	0.0035	0.0140	0.0364	0.0199	n/a	-179.98	n/a	n/a

Figure 3-12 shows an example of typical verification results with **Print Graphs** selected in the **Printer Output** area of the **System Verification** dialog box. The printed graphical results show the following:

- the name of the device measured
- the serial number of the device
- the parameters measured
- Results of the measurements. Labeled as A in Figure 3-12.
- Data measured at the factory from the verification kit. Labeled as B in Figure 3-12.
- Upper and lower limit points as defined by the total system uncertainty system. Labeled as C in Figure 3-12.

Figure 3-12 Example of Printed Graphical Verification Results

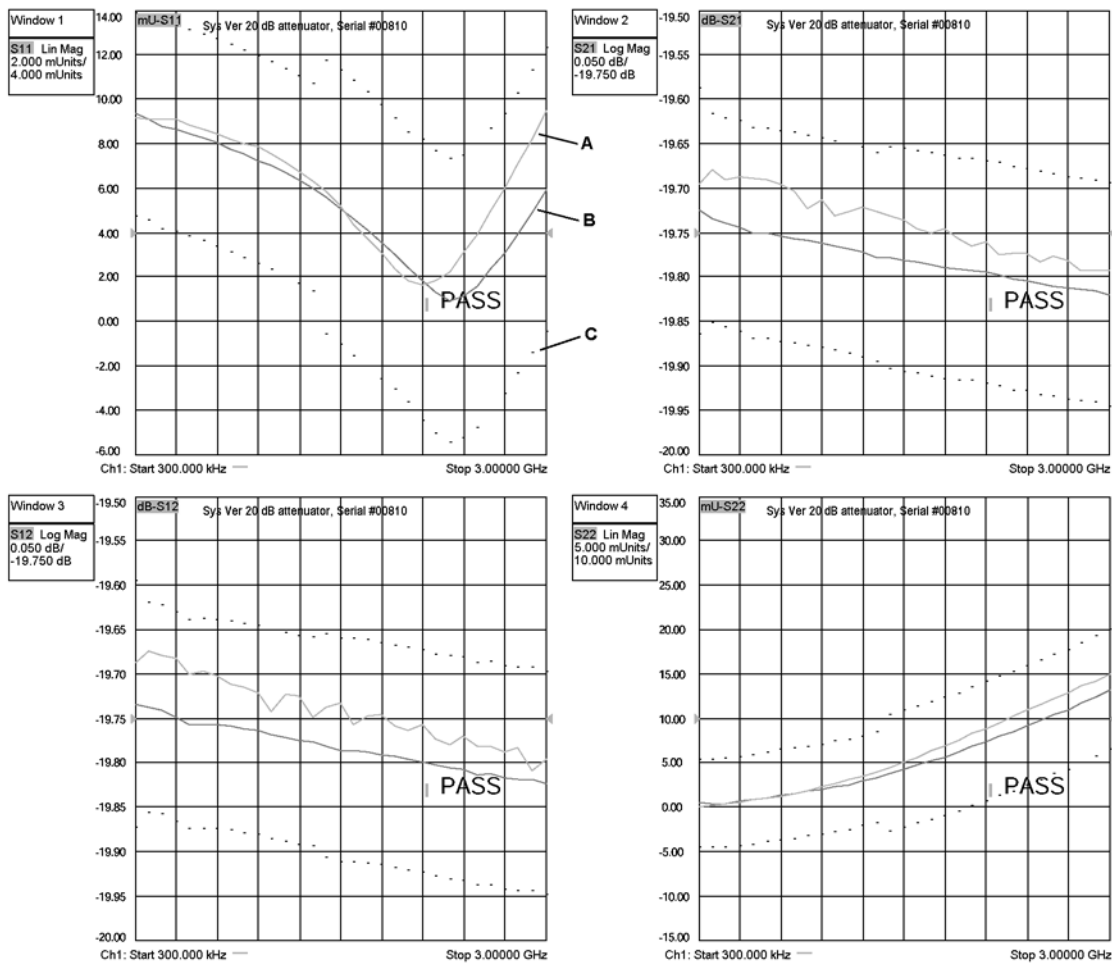

Performance Tests

The performance tests verify the electrical performance of your PNA. These performance tests are included in the analyzer's firmware with Option 897 and Option 898. Your analyzer is automatically configured for each individual test.

The model numbers of the equipment used by these performance tests are specified under "[Required Service Test Equipment](#)" on page 2-5.

There are nine tests in the Option 897 or 898 performance test package:

- [Source Power Accuracy Test](#)
- [Source Maximum Power Output Test](#)
- [Source Power Linearity Test](#)
- [Frequency Accuracy Test](#)
- [Trace Noise Test](#)
- [Receiver Compression Test](#)
- [Noise Floor Test](#)
- [Calibration Coefficients Test](#)
- [Dynamic Accuracy Test](#)

Source Power Accuracy Test

Function of the Test: To confirm the accuracy of the source output power of your network analyzer over its full frequency range.

Specification Tested: Test Port Output–Power Level Accuracy

Equipment Used:

- Power meter
- Power sensors
- Any necessary adapters

Description of the Test:

1. The analyzer is Preset.
2. The analyzer is set up for a CW reflection measurement on the test port to be measured.
3. A power sensor is connected to the test port, using any necessary adapters.
4. The analyzer frequency is set to the desired value.
5. The power meter correction table is set to the same frequency.
6. The output power is measured, and the value is compared to the Preset setting.
7. This process is repeated at hundreds of frequencies across the analyzer's full range. The difference between the measured power and the output setting must fall within the specified accuracy range at all points for the test to pass.

If the Analyzer Fails this Test:

- Perform the ["Source Adjustment"](#) on page 3-42 and repeat this test.
- If the analyzer still fails this test, troubleshoot the source section of the analyzer and then repeat this test. Refer to ["Checking the Source Group"](#) on page 4-30.

Source Maximum Power Output Test

Function of the Test: To confirm the maximum source output power of your network analyzer over its full frequency range.

Specification Tested: Test Port Output–Maximum Levelled Power

Equipment Used:

- Power meter
- Power sensors
- Any necessary adapters

Description of the Test:

1. The analyzer is Preset.
2. The analyzer is set up for a CW reflection measurement on the test port to be measured.
3. A power sensor is connected to the test port, using any necessary adapters.
4. The analyzer frequency is set to the desired value.
5. The power meter correction table is set to the same frequency.
6. The analyzer's output power is increased until a "Source Unlevelled" error is detected. The output power is then decreased in increments of 0.01 dB until the error goes away. If the output power reaches +18 dBm without any error, the power is left at this level.
7. The power level at this point is measured and compared to the maximum output power specification.
8. This process is repeated at hundreds of frequencies across the analyzer's full range in every specified path configuration.

If the Analyzer Fails this Test:

Troubleshoot the source section of the analyzer and then repeat this test. Refer to "[Checking the Source Group](#)" on page 4-30.

Source Power Linearity Test

Function of the Test: To verify that the power level is linear over the analyzer's frequency range and to check the linearity of the automatic leveling control (ALC).

Specification Tested: Power Sweep Range and Power Level Linearity

Equipment Used:

- Test cable
- 20 dB attenuator if the analyzer does not have an internal step attenuator

Description of the Test:

Ports 1 and 2 are tested as a pair. The Port 2 receiver is used to test the linearity of the source power out of Port 1, and vice versa. Ports 3 and 4 are similarly tested as a pair on 4-Port analyzers. The receiver linearity is the standard against which the source linearity is checked.

1. The analyzer is Preset.
2. The analyzer is set up for a CW transmission measurement on the test port pair to be measured.
3. A test cable is connected between the port pair to be tested with 20 dB of attenuation in series with the cable. This is done with an internal source step attenuator or an external 20 dB attenuator. This attenuation ensures that the receiver remains in its linear range.
4. The receiver measurement is normalized at this Preset power level.
5. The source setting is then stepped from the minimum to the maximum ALC power setting range in 1 dB steps, and the receiver power is measured at each setting.
6. The non-linearity in dB at each frequency point is calculated as the difference between the change in the source power setting away from Preset and the change in the receiver power reading.
7. This power linearity measurement is repeated at several CW frequencies across the full frequency range of the analyzer.

If the Analyzer Fails this Test:

- Perform the ["Source Adjustment"](#) on page 3-42 and repeat this test.
- If the analyzer still fails this test, troubleshoot the source section of the analyzer and then repeat this test. Refer to ["Checking the Source Group"](#) on page 4-30.

Frequency Accuracy Test

Function of the Test: To verify the frequency accuracy and range of the analyzer's source output.

Specification Tested: Test Port Output–CW Accuracy

Equipment Used:

- Frequency counter
- Test cable
- Adapters

Description of the Test:

This test is performed over the full frequency range of the source synthesizer board, not the full frequency range of the analyzer. To generate the higher frequencies, the analyzer passes the synthesizer signal through a series of frequency doublers. These doublers exactly double the source frequency, so the deviation from a perfectly accurate frequency is exactly doubled. The frequency accuracy is specified as the ratio parts per million (ppm), so this ratio is unaffected by the signal doubling. Therefore, only the frequency accuracy of the synthesizer board needs to be tested.

1. The analyzer is Preset.
2. The analyzer is set up for a CW measurement on Port 1.
3. A test cable is connected between Port 1 and a frequency counter with any necessary adapters.
4. The signal frequency is measured and compared with the analyzer source frequency setting. The difference must be less than the source frequency divided by 10^6 for a 1 part per million (ppm) specification.
5. This test is repeated at several frequencies across the range of the source synthesizer board.

If the Analyzer Fails this Test:

- Verify the accuracy of the 10 MHz OCXO by using a frequency counter to measure the rear-panel 10 MHz REF OUT. If the 10 MHz reference is off by more than 10 Hz, perform the **"10 MHz Frequency Reference Adjustment"** on page 3-40 and then repeat this test.

Trace Noise Test

Function of the Test: To measure the stability of a signal in the internal source and receiver system of your analyzer.

Specification Tested: Test Port Input–Trace Noise Magnitude and Trace Noise Phase

Equipment Used: A test cable.

Description of the Test:

Trace Noise is a calculation of the standard deviation of a 201 point CW measurement. In a healthy analyzer, this measurement is only affected by the sampling error of the analog to digital converters on the SPAM board.

Ports 1 and 2 are tested as a pair using S_{21} and S_{12} measurements. Ports 3 and 4 are similarly tested as a pair on 4-port analyzers using S_{43} and S_{34} measurements.

1. The analyzer is Preset.
2. The analyzer is set up for a 201 point CW transmission measurement for the port pair to be tested with the specified IF bandwidth (typically 1 kHz). Both a magnitude and a phase trace are displayed.
3. A test cable is connected between the port pair to be tested.
4. The analyzer is set to a series of CW frequencies across its full frequency range. The analyzer's trace statistics function is used to calculate the standard deviation of both the magnitude trace and the phase trace.
5. These standard deviation values are reported as the analyzer's trace noise and are compared with the Trace Noise magnitude and phase specifications.

If the Analyzer Fails this Test:

A failure of this test indicates a fault in the receiver's IF chain between the mixer and the A12 SPAM board. This can indicate a faulty assembly or a loose cable.

- Check for proper torquing of all semi-rigid cables in the receiver chain, and then repeat this test.
- If the analyzer still fails this test, replace the A12 SPAM board and repeat this test. Most failures are due to this board. Refer to ["Removing and Replacing the A4–A17 Boards"](#) on page 7-14.
- If the analyzer still fails this test, replace the mixer module for the failing receiver, and then repeat this test.

Receiver Compression Test

Function of the Test: To measure the compression at the analyzer's specified maximum power level for the receivers.

Specification Tested: Test Port Input–Maximum Test Port Input Level

Equipment Used:

- U3070AK01 or Z5623A Option K01 Compression Test Set
- Power meter
- Power sensors
- Two test cables
- Calibration kit
- 10-dB and 20-dB pads if the analyzer does not have an internal step attenuator

Description of the Test:

For most analyzer models, the receiver compression level is higher than the maximum source output power. Therefore, an external amplifier is required. This test also requires that two attenuators be switched in and out of the RF path. These requirements are met with the use of the Compression Test Set. The procedure outlined here is for those models which require the test set.

1. The analyzer is Preset. The two test set output attenuators are set to 0 dB.
2. The analyzer is set up for a 201 point CW transmission measurement for the port pair to be tested with the specified IF bandwidth (typically 1 kHz).
3. A test cable is connected between the analyzer source port and the test set input port. A test cable is connected to the test set output port.
4. A power sensor is connected to the end of the test cable.
5. For a series of CW frequencies across the analyzer's full frequency range, the source output level is adjusted to achieve the specified receiver compression power level (typically the receiver's maximum input power level).
6. The power sensor is disconnected from the test cable and the cable is connected to the port to be tested.
7. The analyzer steps through each CW frequency as the absolute log magnitude value (dBm) and the relative phase for the receiver under test is read (P_a).
8. The first test set output attenuator is set to 20 dB.
9. The magnitude and phase measurements using the receiver under test are read: (P_b).
10. The second test set output attenuator is set to 20 dB.
11. The magnitude and phase measurements using the receiver under test are read: (P_c).
12. The first test set output attenuator is set to 0 dB.
13. The magnitude and phase measurements using the receiver under test are read: (P_d).
14. The compression for each point is calculated as $(P_a - P_b) - (P_d - P_c)$.

If the Analyzer Fails this Test:

- Run the Receiver Characterization adjustment, and repeat this test.
- If the analyzer still fails this test, replace the A23 mixer brick for a Port 1 or Port 2 failure or the A24 mixer brick for a Port 3 or Port 4 failure, then repeat this test. Refer to [“Removing and Replacing the A27 and A28 Mixer Bricks”](#) on page 7-34.

Noise Floor Test

Function of the Test: To measure the absolute power level of the noise floor for the analyzer's receivers.

Specification Tested: Test Port Input–Test Port Noise Floor

Equipment Used:

- Power meter
- Power sensors
- Test cable
- Calibration kit

Description of the Test:

This test uses the source signal out of one analyzer test port as part of the noise floor measurement on another test port. Port 2 is the source port when measuring the noise floor of Port 1. Port 1 is the source port when measuring the noise floor of Ports 2, 3, and 4.

1. The analyzer is Preset.
2. The analyzer is set up for a CW transmission measurement between the source port and the test port to be measured. The analyzer is set to an IF bandwidth of 1 kHz and 801 points per sweep.
3. A test cable is connected to the source port.
4. A power sensor is connected to the end of the test cable with any necessary adapters.
5. For hundreds of frequencies across the analyzer's full range, a source power calibration is performed to ensure a flat power response at the end of the cable at the Preset power level.
6. The power sensor is disconnected and the cable is connected to the port to be tested.
7. A CW linear measurement sweep is measured for each test point. The receiver reference power level, P_{ref} , in dBm is calculated for each point from the mean of each sweep.
8. The test cable is removed and loads are connected to both ports.
9. A CW linear measurement sweep is measured for each test point. The receiver test power level, P_{test} , in dBm is calculated for each point from the mean of each sweep.
10. The corrected noise floor in dBm is calculated for a 10 Hz IF bandwidth using: $P_{NoiseFloor} = P_{test} - 19.96 \text{ dB} - (\text{Preset Power} - P_{ref})$.

If the Analyzer Fails this Test:

- If the analyzer fails this test, replace the A23 mixer brick for a Port 1 or Port 2 failure or the A24 mixer brick for a Port 3 or Port 4 failure, then repeat this test. Refer to ["Removing and Replacing the A27 and A28 Mixer Bricks"](#) on page 7-34.
- If the analyzer still fails this test, replace the A12 SPAM board and then repeat this test. Refer to ["Removing and Replacing the A4–A17 Boards"](#) on page 7-14.

Calibration Coefficients Test

Function of the Test: To verify the uncorrected calibration coefficients of your analyzer. The calibration coefficients are specified at the test port without any cables, so calibrations must be performed in both the forward and reverse directions to eliminate the effects of the test cable.

Specification Tested: Uncorrected System Performance

Equipment Used:

- Calibration kit
- Test cable

Description of the Test:

Two full SOLT 2-port calibrations are performed on each port pair. Ports 1 and 2 are tested as a pair. Ports 3 and 4 are tested as a pair on 4-port analyzers. Isolation is turned off during each calibration.

1. A test cable is connected to Port 1.
2. A calibration is performed between the end of the test cable and Port 2. The Port 2 directivity and source match and the S_{21} load match are retrieved from the analyzer.
3. The test cable is moved to Port 2.
4. A calibration is performed between the end of the test cable and Port 1. The Port 1 directivity and source match and the S_{12} load match are retrieved from the analyzer.
5. On some older analyzer models, the reflection tracking and transmission tracking error terms were also specified. For those models, these error terms are also retrieved from the analyzer.
6. This process is repeated for Ports 3 and 4 on 4-port analyzers.

If the Analyzer Fails this Test:

- Failure of the directivity error term is often due to a faulty test port coupler. Replace the coupler and repeat this test.
- Failure of the source or load match error terms is due to faulty hardware between the test port and the internal source. Refer to [Chapter 7, "Repair and Replacement Procedures,"](#) for instructions on replacing the suspected faulty component or assembly.

Dynamic Accuracy Test

This description applies to all N522xA, N5231A/32A/34A/35A/39A, and N5247A instruments.

Function of the Test: To measure the relative power linearity of the analyzer's receivers.

Specification Tested: Test Port Input–Dynamic Accuracy

Equipment Used:

- U3020AD01 dynamic accuracy test set
- Signal generator
- Power meter
- Power sensor
- Two test cables

Description of the Test:

1. The analyzer's test ports are tested separately at a specific CW frequency and a reference power level of -20 dBm.
2. A test cable is connected between the analyzer's source port and the dynamic accuracy test set's Source 1 In port. A test cable is connected between the signal generator and the test set's Source 2 In port. A test cable is connected to the test set's Receiver Out port, and the power sensor is connected to the end of this cable.
3. The test set's output attenuator is set to 20 dB. With the signal generator RF turned off, the PNA source power is adjusted until the power sensor reads -20 dBm. The PNA source is then turned off, the signal generator RF is turned on, and the signal generator power is adjusted until the power sensor reads -20 dBm.
4. The power sensor is disconnected and the test cable is attached to the analyzer port under test.
5. Both sources are turned on and the signal generator's frequency is set to 2 Hz above the analyzer's frequency. By combining these two signals together, the resultant signal will be a perfect sine wave with a magnitude which varies from -17 dBm to -23 dBm at a rate of 2 Hz.
6. The analyzer's receiver measurement is retrieved and compared with a perfect sine wave. Any deviation is due to receiver non-linearity.
7. The test set's output attenuator is changed in 5 dB steps from 0 to 60 dB, and this measurement is repeated.
8. With the 1 dB of overlap in each measurement, the data for each attenuator setting can be stitched together to provide a complete receiver linearity profile from +3 dBm to -63 dBm.
9. This test is repeated for each receiver.

If the Analyzer Fails this Test:

- If the analyzer fails this test, rerun the test.
- If the analyzer fails this test repeatedly, replace the A23 mixer brick for a Port 1 or Port 2 failure or the A24 mixer brick for a Port 3 or Port 4 failure, then repeat this test. Refer to ["Removing and Replacing the A27 and A28 Mixer Bricks"](#) on page 7-34.
- If the analyzer still fails this test, replace the A12 SPAM board and repeat this test. Refer to ["Removing and Replacing the A4–A17 Boards"](#) on page 7-14.

Adjustments

These adjustments are firmware-driven tests that are used to fine-tune your analyzer.

If multiple adjustments are to be performed, perform them in the order listed.

- “10 MHz Frequency Reference Adjustment” on page 3-40
- “IF Gain Adjustment” on page 3-41
- “Synthesizer Bandwidth Adjustment” on page 3-41
- “Source Adjustment” on page 3-42
- “Receiver Adjustment” on page 3-43
- “Receiver Characterization” on page 3-46
- “EE Default Adjustment” on page 3-46

These adjustments are described on the following pages.

10 MHz Frequency Reference Adjustment

The 10 MHz frequency adjustment is used to adjust the frequency accuracy of the network analyzer's 10 MHz frequency reference on the A14 frequency reference board assembly.

Equipment Used for the 10 MHz Frequency Reference Adjustment

Equipment Type	Model or Part Number	Alternate Model or Part Number
Cable, BNC, 50*, 24 inch	8120-1839	Any
Frequency counter	53151A, Option 001	Any that will measure a signal at 10 MHz.

Procedure

NOTE This adjustment typically adjusts to within ± 0.01 ppm.

1. Connect the equipment as shown in **Figure 3-13**. Connect a GPIB cable between the network analyzer and the frequency counter.

Figure 3-13 Equipment Setup for the 10 MHz Frequency Reference Adjustment

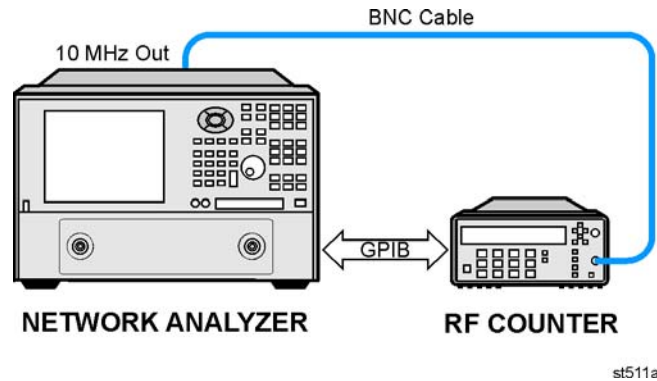

2. Press UTILITY **System**, then **Service**, then **Adjustments**, then click **10 MHz Freq Adjustment**.
3. Ensure the GPIB settings are correct.
4. Follow the instructions and prompts as they are displayed.

IF Gain Adjustment

The IF gain adjustment is used to adjust the IF gain of the network analyzer.

Procedure

1. Press UTILITY **System** , then **Service** , then **Adjustments** , then click **IF Gain Adjustment**.
2. Follow the instructions and prompts as they are displayed.

Synthesizer Bandwidth Adjustment

This adjusts the bandwidth of the 13.5 GHz synthesizers.

Procedure

1. Press UTILITY **System** , then **Service** , then **Adjustments** , then click **Synthesizer Bandwidth Adj.**
2. Follow the instructions and prompts as they are displayed.

Source Adjustment

The source calibration is used to adjust your network analyzer for a flat source power across its full frequency range. There are differences between each test port; therefore, an adjustment is required for each port.

Equipment Used for the Source Adjustment

Equipment Type	Model or Part Number	Alternate Model or Part Number
Power meter	E4418B/E4419B	E4418A/E4419A
Power sensor, 2.4 mm	8487A	None
Adapter, 2.4 mm (f) to 2.4 mm (f)	11900B	85056-60007

Procedure

1. Connect the equipment as shown in [Figure 3-14](#). Connect a GPIB cable between the network analyzer and the power meter.

Figure 3-14 Equipment Setup for the Source Adjustment

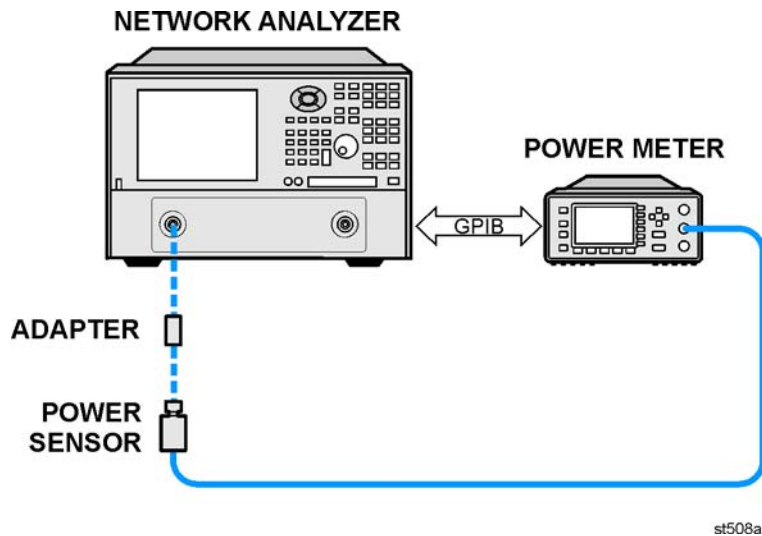

2. Press UTILITY **System**, then **Service**, then **Adjustments**, then click **Source Adjustment**.
3. Ensure the GPIB settings are correct.
4. Follow the instructions and prompts as they are displayed.

Receiver Adjustment

The receiver calibration is used to adjust the network analyzer receivers for a flat response across its full frequency range:

1. A power meter/sensor is connected to Port 1, as shown in [Figure 3-15](#), to establish a reference for flatness.
2. A cable is inserted between the power sensor and the test port, as shown in [Figure 3-16](#), to establish a reference for the cable.
3. The same cable is connected between test port 1 and test port 2, as shown in [Figure 3-17](#), and a signal from Port 1 is used to adjust the “B” receiver at Port 2.

The adjustment is repeated using a signal from Port 2 to adjust the “A” receiver at Port 1.

Data obtained during this adjustment are stored in the mxcalfile_pxx files in flash memory on the test set motherboard, with a backup copy stored on the hard disk drive. The data are used in subsequent measurements.

Solid state drives can be swapped or replaced without concern for the mxcalfile_pxx files. If the test set motherboard is replaced, the PNA firmware will automatically create new primary mxcalfile_pxx files from the backup copies on the hard drive.

These files can be recreated by performing another receiver calibration adjustment.

Equipment Used for the Receiver Adjustment

Equipment Type	Model or Part Number	Alternate Model Part Number
Power meter	E4418B/E4419B	E4418A/E4419A
Power sensor, 2.4 mm	8487A	None
Adapter, 2.4 mm (f) to 2.4 mm (f)	11900B	85056-60007
RF Cable, 2.4 mm (f) to 2.4mm (f)	85133C	85133E

Procedure

1. Connect the equipment as shown in [Figure 3-15](#). Connect a GPIB cable between the network analyzer and the power meter.

Figure 3-15 Equipment Setup 1 for the Receiver Adjustment

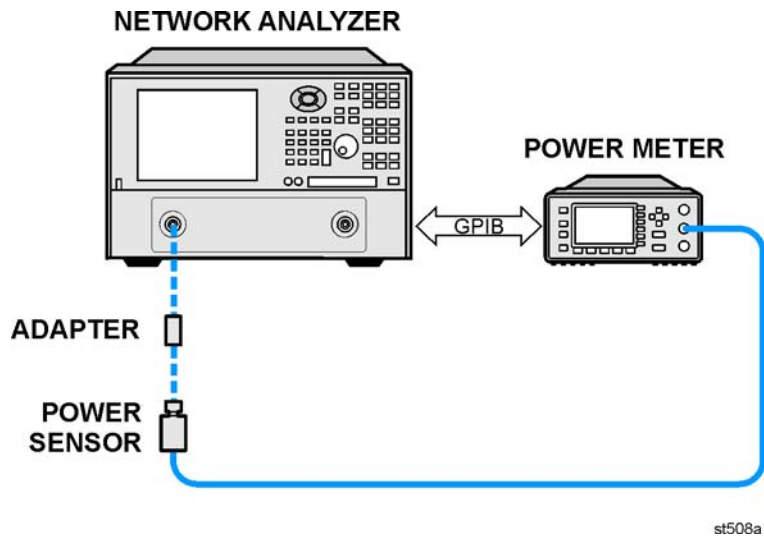

2. Press UTILITY **System** , then **Service** , then **Adjustments** , then click **Receiver Adjustment**.
3. Ensure the GPIB settings are correct.
4. Follow the instructions and prompts as they are displayed.

Figure 3-16 Equipment Setup 2 for the Receiver Adjustment

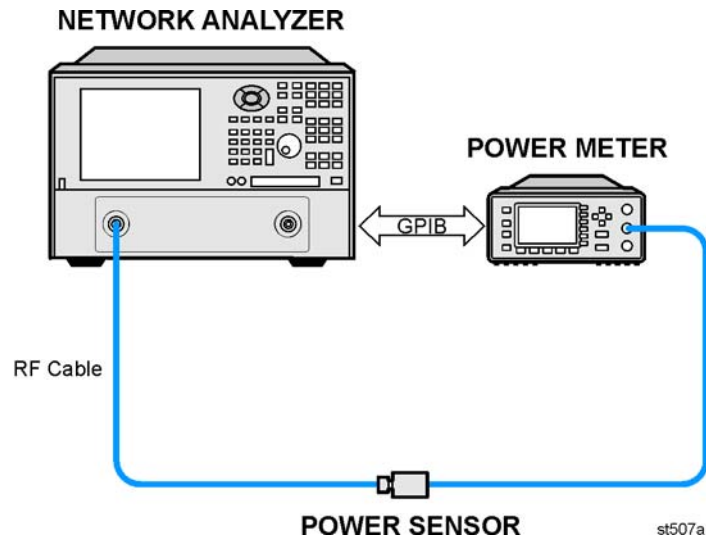
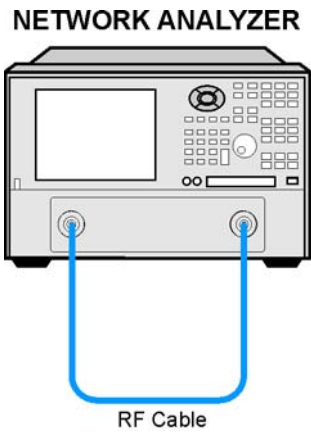

Figure 3-17 **Equipment Setup 3 for the Receiver Adjustment**



st509a

Receiver Characterization

This characterizes the receivers in your analyzer.

Procedure

1. Press UTILITY **System** , then **Service** , then **Adjustments** , then click **Receiver Characterization**.
2. Follow the instructions and prompts as they are displayed.

EE Default Adjustment

This sets the EEPROM data to their default values.

Procedure

1. Press UTILITY **System** , then **Service** , then **Adjustments** , then click **EE Default Adjustment**.
2. On the dialog box, select **Initialize** rather than **Adjust/Verify** because an adjustment is typically unnecessary.
3. Follow the instructions and prompts as they are displayed.

4 Troubleshooting

Information in This Chapter

The information in this chapter helps you:

- Identify the portion of the analyzer at fault.
- Locate the specific troubleshooting procedure to identify the assembly or peripheral at fault.

The sections in this chapter are arranged in a logical troubleshooting order. The following table lists the sections and a brief summary of what to look for in that section.

Chapter Four at-a-Glance

Section Title	Summary of Content	Start Page
'Getting Started with Troubleshooting'	A starting point for troubleshooting.	Page 4-4
'Power Up Troubleshooting'	Power-up problems: <ul style="list-style-type: none"> • Power supply problems • LCD problems • Bootup for the network analyzer interface 	Page 4-6
'Front Panel Troubleshooting'	Problems occurring after the network analyzer interface is loaded: <ul style="list-style-type: none"> • Does the display color appear correct? • Do the front panel keys function properly? • Does the front panel USB connector function properly? 	Page 4-13
'Rear Panel Troubleshooting'	Problems associated with the rear panel interconnects. <i>The data found at these rear panel interconnects can be used to troubleshoot the CPU board.</i>	Page 4-17
'Measurement System Troubleshooting'	Problems with the measurement portion of the analyzer. <ul style="list-style-type: none"> • Checking the A, B, R1, and R2 signals. • Checking the source group. • Checking the signal separation group. • Checking the receiver group. 	Page 4-23
Instrument Block Diagrams	Block diagrams for the analyzer including all options.	Page 4-43

Conventions Used for Hardkeys, Softkeys, and Menu Items

The following conventions are used in this document:

Hardkey

This represents a “hardkey”, a key that is physically located on the instrument.

Softkey

This represents a “softkey”, a key whose label is determined by the instrument firmware.

Menu Item

This represents an item in a drop-down or pop-up menu.

Operating the Analyzer With Covers Removed

CAUTION Do not operate the analyzer with the outer cover removed for more than 30 minutes, as this could cause the analyzer to overheat which could result in costly damage.

Protect Against Electrostatic Discharge (ESD)

This is important. If not properly protected against, electrostatic discharge can seriously damage your analyzer, resulting in costly repair.

CAUTION To reduce the chance of electrostatic discharge, follow all of the recommendations outlined in “[Electrostatic Discharge Protection](#)” on page 1-6, for all of the procedures in this chapter.

Assembly Replacement Sequence

After identifying the problem requiring an assembly to be replaced, follow these steps:

- Step 1.** Order a replacement assembly. Refer to [Chapter 6, “Replaceable Parts.”](#)
- Step 2.** Replace the faulty assembly and determine what adjustments are necessary. Refer to [Chapter 7, “Repair and Replacement Procedures.”](#)
- Step 3.** Perform the necessary adjustments. Refer to [Chapter 3, “Tests and Adjustments.”](#)
- Step 4.** Perform the necessary performance tests. Refer to [Chapter 3, “Tests and Adjustments.”](#)

Getting Started with Troubleshooting

Where you begin troubleshooting depends upon the symptoms of the failure. Start by checking the basics as outlined in the following section. Also review the flowchart in [Figure 4-1 on page 4-5](#). You should then be able to determine where in the troubleshooting procedure to begin, to locate the failed assembly.

Check the Basics

A problem can often be solved by repeating the procedure you were following when the problem occurred. Before calling Keysight Technologies or returning the instrument for service, please perform the following checks:

1. Is there power at the mains receptacle? If not, correct this situation and proceed.
2. Is the instrument turned on? Check to see if the front panel line switch displays a light. This indicates the power supply is on. If the front panel line switch is on but the power supply does not appear to be on, go to [“Power Up Troubleshooting” on page 4-6](#).
3. Is the Windows® operating system running? If not, refer to [“Operating System Recovery” on page 8-18](#) for instructions.
4. If other equipment, cables, and connectors are being used with the instrument, make sure they are clean, connected properly and operating correctly.
5. Review the procedure for the measurement being performed when the problem appeared. Are all the settings correct? If not, correct them.

If the instrument is not functioning as expected, return the unit to a known state by pressing the UTILITY Preset key.

6. Is the measurement being performed, and the results that are expected, within the specifications and capabilities of the instrument? Refer to the embedded help in the analyzer for instrument specifications.
7. If the problem is thought to be due to firmware, check to see if the instrument has the latest firmware before starting the troubleshooting procedure. Refer to [“Firmware Upgrades” on page 8-17](#) for instructions.
8. If the necessary test equipment is available, perform the operator’s check and system verification in [Chapter 3, “Tests and Adjustments.”](#)

Troubleshooting Organization

Follow the flowgraph in [Figure 4-1](#) to help direct you to the correct section for troubleshooting the analyzer.

Figure 4-1 Troubleshooting Organization Flowchart

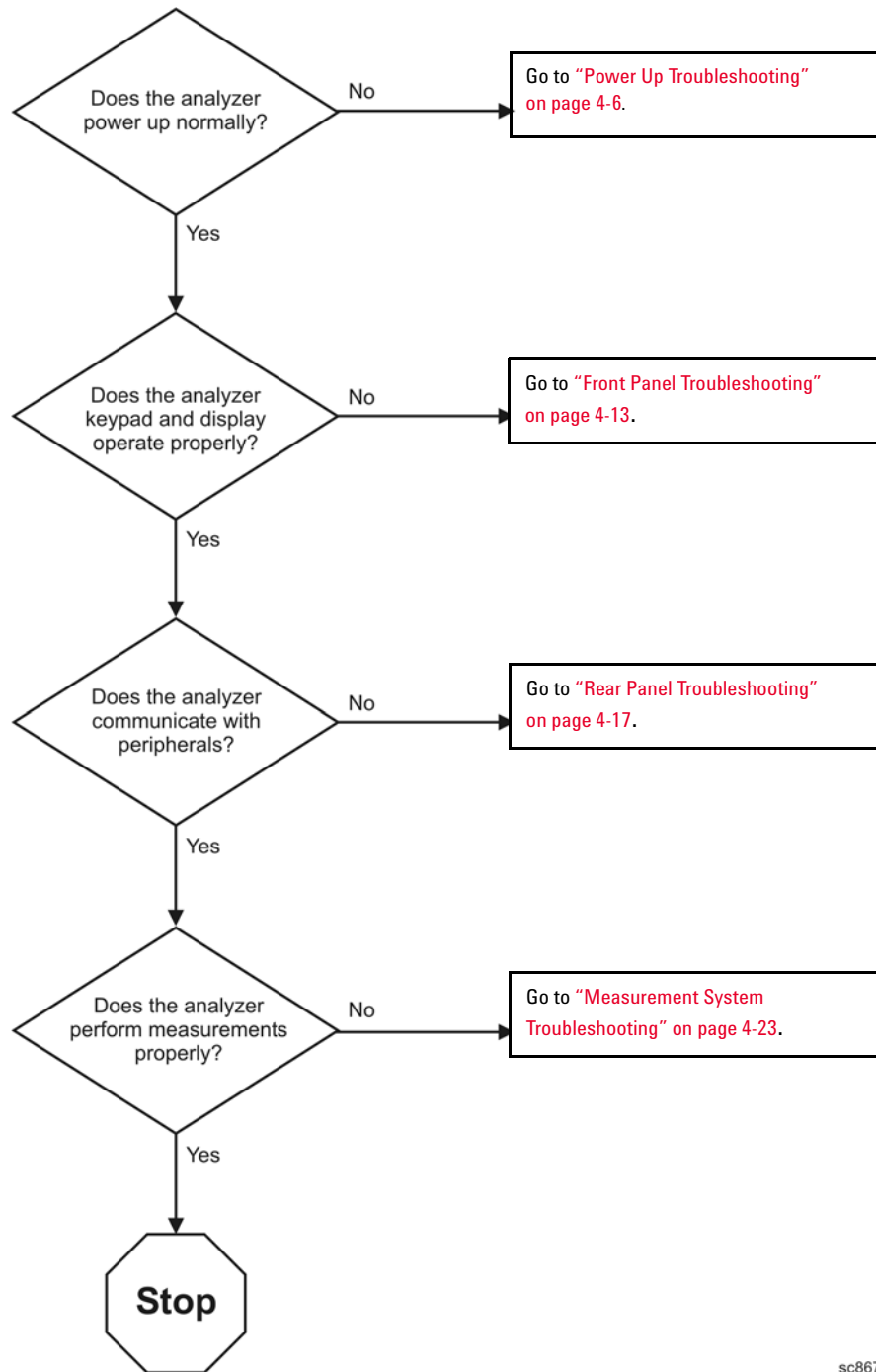

sc867b

Power Up Troubleshooting

WARNING Immediately unplug the instrument from the ac power line if the unit shows any of the following symptoms:

- **Smoke, arcing, or unusual noise from inside the analyzer.**
 - **A circuit breaker or fuse on the main ac power line opens.**
-

Check your network analyzer for evidence that it is powering up correctly. Perform the following steps and make sure that the analyzer is displaying correct behavior as noted in the following steps.

Step 1. Disconnect all peripherals and plug in the network analyzer. Before the analyzer is powered on, the line switch should glow yellow and no other lights should be on.

Step 2. Turn on the network analyzer.

- The line switch should glow green.
- The fans should be audible.
- The display should flash and then show the hardware boot-up sequence. This process checks the RAM and communication with the solid state drive. These checks return an error message if a problem is detected.
- The Windows operating system should start.
- The network analyzer measurement interface should open with an S_{11} measurement displayed.

Step 3. If the analyzer powers up correctly, continue troubleshooting with [“Front Panel Troubleshooting” on page 4-13.](#)

Step 4. If the analyzer does not power up correctly, follow these troubleshooting steps:

- If the line switch does not glow, go to [“Power Supply Check” on page 4-7.](#)
- If you cannot hear the fans operating, go to [“If the Fans Are Not Operating” on page 4-11.](#)
- If the line switch displays a green light and the fans are operating (audible), but the display remains dark, go to [“Troubleshooting LCD Display Problems” on page 4-12.](#)
- If the instrument appears to abort the network analyzer measurement interface process, contact Keysight. Refer to [“Contacting Keysight” on page 2-8.](#)

Power Supply Check

NOTE There are no fuses to replace within the power supply. If you determine that the power supply is the failed assembly, replace the power supply.

A catastrophic failure in the power supply can be determined by observing the line switch and the power supply LED indicators:

1. Ensure that the instrument is plugged in with the power switch in the standby position (power not switched on). Verify that the line switch displays a yellow light - this indicates that the power supply standby line is active and functional.
2. Turn on the instrument power and verify that the line switch displays a green light - this indication that the power supply is active and does not sense an over-current condition.
3. You can determine which power supplies are functioning by viewing the LED indicators on the A19 midplane board. Refer to [Figure 4-2](#).

To view the LED indicators, it is necessary to remove the instrument's outer and inner covers. Refer to ["Removing the Covers" on page 7-6](#) for removal procedures. To determine the location of the A19 midplane board, refer to ["Top Assemblies and Cables, All Options" on page 6-16](#).

CAUTION Do not operate the analyzer with the outer cover removed for more than 30 minutes, as this could cause the analyzer to overheat which could result in costly damage.

4. If any power supply voltage is missing, it is likely that the problem is a defective A20 power supply, the A19 midplane board, or another assembly that is loading down the A20 power supply. Continue with ["If Any Supply Voltage Is Missing" on page 4-9](#) to determine the cause of the problem.
5. If the line switch is lit correctly, and all the power supply voltages appear to be present, as indicated by the LEDs as shown in [Figure 4-2](#), the power supply has not suffered a catastrophic failure. However, the power supply could still be at fault. Continue at ["Measure the Individual Supply Voltages"](#) to verify that the actual supply voltages are correct.

Measure the Individual Supply Voltages

Measure the power supply voltages using a digital multi-meter. Use the point labeled ACOM as ground reference for analog supplies and the point marked DCOM as ground reference for digital supplies.

Refer to [Figure 4-2](#) for the power supply measurement points on the A19 midplane board. Refer to [Table 4-1 on page 4-9](#) for the correct voltages.

Figure 4-2 A19 Midplane Board Power Supply LED Indicators and Measurement Points

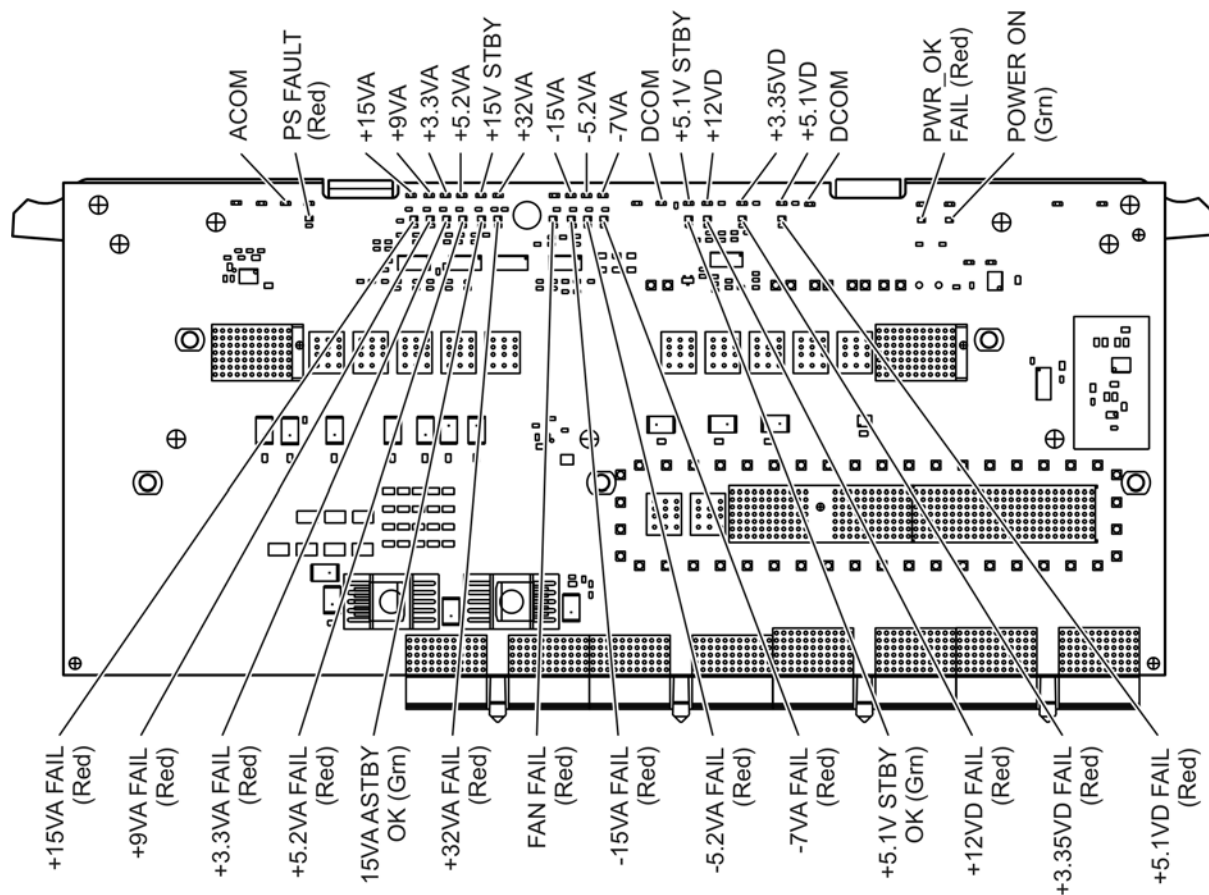

n5242_001_402

WARNING The instrument contains potentially hazardous voltages. Refer to the safety symbols provided on the instrument and in **“General Safety Considerations”** on page 1-3 before operating the unit with the cover removed. Make sure that the safety instructions are strictly followed. Failure to do so can result in personal injury or loss of life.

CAUTION Do not operate the analyzer with the outer cover removed for more than 30 minutes, as this could cause the analyzer to overheat which could result in costly damage.

NOTE If any one individual voltage supply from the A20 power supply develops an over-voltage or over-current problem, all supplies are affected. The cause of the over-voltage or over-current condition can be the A20 power supply itself, or any assembly to which the A20 power supply provides voltage. To isolate the cause, continue to the assembly removal process as described in the section titled **“If Any Supply Voltage Is Missing”** on page 4-9.

Table 4-1 Power Supply Measurement Points

Test Point	Supply Name	Expected Level (Vdc)	Test Point	Supply Name	Expected Level (Vdc)
TP517	Analog Ground	0 V	TP516	-5.2 V analog	-5.2 ±0.1
TP509	+15 V analog	+15.0 ±0.1	TP514	-7 V analog	-7.0 ±0.1
TP511	+9 V analog	+9.0 ±0.1	TP500	Digital Ground	0 V
TP515	+3.3 V analog	+3.3 ±0.1	TP502	+5.1 V standby	+5.1 ±0.1
TP513	+5.2 V analog	+5.2 ±0.1	TP503	+12 V digital	+12.0 ±0.1
TP501	+15 V standby	+15.0 ±0.1	TP507	+3.35 V digital	+3.35 ±0.1
TP504	+32 V analog	+32.0 ±0.1	TP505	+5.1 V digital	+5.1 ±0.1
TP512	-15 V analog	-15.0 ±0.1	TP519	Digital Ground	0 V

If All Supply Voltages are Present

If all of the supplies have measured within tolerances, and the instrument still is not functioning properly, refer to **“Front Panel Troubleshooting”** on page 4-13.

If Any Supply Voltage Is Missing

WARNING **Disconnect the line-power cord before removing any assembly. Procedures described in this document may be performed with power supplied to the product while protective covers are removed. Energy available at many points may, if contacted, result in personal injury or loss of life.**

You must sequentially remove all of the assemblies, taking care to disconnect the line power cord before each removal, and then measure the supply voltages after each removal.

If the missing supply voltages return to a “power on” condition after removal of an assembly, suspect that assembly as being defective.

Remove the network analyzer assemblies in the order specified in the following steps (refer to **Chapter 7** for removal instructions).

1. Unplug the A23 test set motherboard ribbon cable from the A23 test set motherboard (refer to **“Removing and Replacing the A23 Test Set Motherboard”** on page 7-26).
1. Unplug the A23 test set motherboard to A24 IF multiplexer board ribbon cable from the A24 IF multiplexer board (refer to **“Removing and Replacing the A24 IF Multiplexer Board”** on page 7-28).
2. Unplug the front panel interface cable from the A1 front panel interface board (refer to **“Removing and Replacing the A1–A3 and Other Front Panel Subassemblies”** on page 7-10).
3. Remove the A16 SPAM board (refer to **“Removing and Replacing the A4–A17 Boards”** on page 7-14).
4. Remove the A10 source board (refer to **“Removing and Replacing the A4–A17 Boards”** on page 7-14).
5. Remove the A5 source board, if present (refer to **“Removing and Replacing the A4–A17 Boards”** on page 7-14).
6. Remove the A15 13.5 GHz synthesizer board (refer to **“Removing and Replacing the A4–A17 Boards”** on page 7-14).

page 7-14).

7. Remove the A17 13.5 GHz synthesizer board (refer to “Removing and Replacing the A4–A17 Boards” on page 7-14).
8. Remove the A4 13.5 GHz synthesizer board, if present (refer to “Removing and Replacing the A4–A17 Boards” on page 7-14).
9. Remove the A14 frequency reference board (refer to “Removing and Replacing the A4–A17 Boards” on page 7-14).
10. Remove the A22 GPIB board (refer to “Removing and Replacing the A22 GPIB Board” on page 7-24). Reinstall the A20 power supply assembly and the A21 CPU board assembly.
11. Unplug the A55 solid state drive from the A21 CPU board (refer to “Removing and Replacing the A55 Solid State Drive (SSD)” on page 7-46).

The minimum required assemblies to power up the analyzer are:

- A20 power supply
- A19 midplane board
- A18 system motherboard
- A21 CPU board

To further isolate the failure in the three remaining assemblies, measure the resistance (with the power turned off) from the power supply test points to either ACOM or DCOM.

NOTE Make sure that the only assemblies plugged in are the four minimum required assemblies listed above.

NOTE Check for shorts (zero Ω) or very low resistance (approximately 1 Ω). If a short or low resistance is measured, isolate each of the remaining four boards in the following order, and recheck the shorted test point after each board is removed. You should be able to determine if the shorted condition has changed.

NOTE Isolate the remaining three assemblies:

- remove the A21 CPU board
- remove the A20 power supply
- remove the A19 midplane board
- This leaves only the A18 system motherboard installed. If the resistance measurements are still incorrect, this is the suspected faulty assembly.

If the Fans Are Not Operating

CAUTION The power supply may be in thermal shutdown if the instrument has been operating without the fans running. Allow the instrument to cool down before troubleshooting.

If all five fans are not operating, suspect a power supply problem or a defective A18 system motherboard. Refer to **“Power Supply Check”** on page 4-7 to check the individual supplies. If the supplies are within specifications, the most probable cause is a defective A18 system motherboard. Refer to **“Removing and Replacing the A18 System Motherboard”** on page 7-16.

If only one or two fans are not functioning, and the power supplies are within specifications, suspect the A18 system motherboard or defective fan(s). Perform the following procedure.

1. Remove the fan bracket, with fans attached, from the analyzer to expose the fan power cable connections on the A18 system motherboard. Refer to **Figure 4-3** for location of these connections. Refer to **“Removing and Replacing the Fans”** on page 7-52.
2. Plug in the power cord and measure the fan voltages at all three connectors on the A18 system motherboard. **THIS MUST BE DONE QUICKLY AS THE ANALYZER WILL RAPIDLY OVERHEAT WITHOUT THE COOLING EFFECT OF THE FANS. DO NOT PLUG IN THE POWER CORD UNTIL READY TO PERFORM MEASUREMENTS.**

Figure 4-3 Fan Power Cable Connections

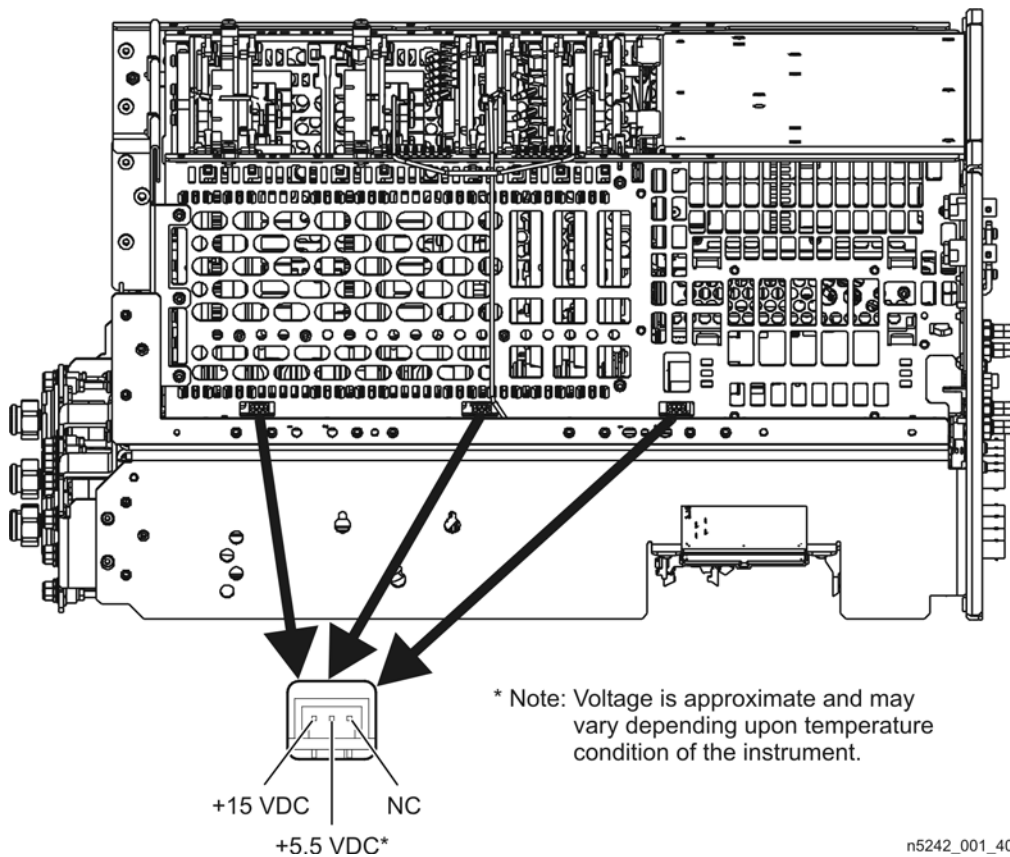

3. If the correct voltage is present at each connection and the fan connectors are in good mechanical condition, suspect a defective fan. Refer to **“Removing and Replacing the Fans”** on page 7-52.

If the correct voltage is not present, suspect a defective A18 system motherboard. Refer to [“Removing and Replacing the A18 System Motherboard”](#) on page 7-16.

Troubleshooting LCD Display Problems

This procedure is intended to isolate the faulty assembly when the display is dark. If the display is lit, but the color mix is faulty, refer to [“A3 Display Test”](#) on page 4-15.

NOTE There are no front panel adjustments for intensity and contrast of the LCD.

1. If the display is dim, the A3 display assembly is defective. Refer to [“Removing and Replacing the A1–A3 and Other Front Panel Subassemblies”](#) on page 7-10.

If the display is dark (not visible), connect an external VGA monitor to the rear panel Monitor output connector. (Be aware that some multisync monitors might not be able to lock to a 60 Hz sync pulse.) If the video information is not present on the external VGA monitor, the most probable cause is the A21 CPU board. Refer to [“Removing and Replacing the A21 CPU Board Assembly”](#) on page 7-22.

2. If the external VGA monitor displays the correct information, verify that the front panel interface ribbon cable is properly plugged into the motherboard connector. Refer to [“Removing and Replacing the Front Panel Assembly”](#) on page 7-8.
3. If the front panel interface ribbon cable is properly connected, suspect that one or more of the following is defective:
 - inverter board (mounted on the display assembly)
 - A1 front panel interface board
 - A3 display assembly

Front Panel Troubleshooting

The front panel assembly consists of the A1 front panel interface board, the keypad, the A2 USB board, and the A3 display assembly. The following tests verify the operation of the front panel assembly when the analyzer is in the measurement mode. If the instrument fails to power up correctly, or it is difficult to verify due to a faulty display, refer to **“Power Up Troubleshooting” on page 4-6**.

Refer to the following sections to verify the operation of the noted assemblies.

- **“Front Panel Keypad and RPG Test”** on this page
- **“A3 Display Test”** on page 4-15
- **“Checking the A2 USB Board”** on page 4-16
- **“A1 Front Panel Interface Board”** on page 4-16

If all assemblies are working correctly, continue troubleshooting with **“Rear Panel Troubleshooting” on page 4-17**.

Front Panel Keypad and RPG Test

Test the front panel keypad by running the front panel test. To run the front panel test, perform the following:

Press UTILITY **System** , then **Service** , then **More** , then **Front Panel Test** .

A **Front Panel Key Test Utility** dialog box will be displayed, as shown in **Figure 4-4**.

Figure 4-4 Front Panel Key Test Utility Dialog Box

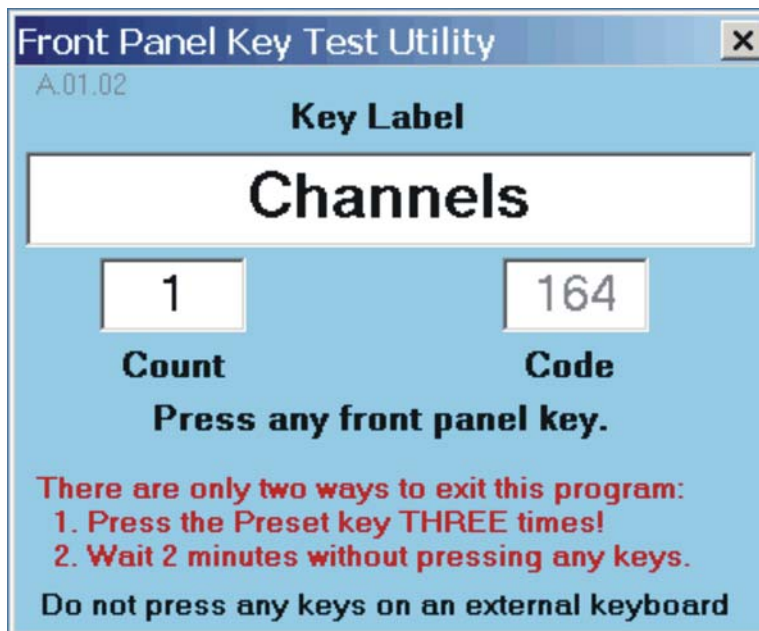

n5242_001_403

Checking the Front Panel Keys

To check the front panel keys, push each key and compare the name in the Key Label box to the name physically labeled on the key cap. These names are also in [Table 4-2](#) below.

- If all the key names are correct, then the front panel keypad is working. If some of the keys are not working, suspect a faulty keypad. To replace the keypad, refer to [“Removing and Replacing the A1–A3 and Other Front Panel Subassemblies”](#) on page 7-10.
- If none of the keys are working correctly, suspect a faulty A1 front panel interface board. To replace the A1 front panel interface board, refer to [“Removing and Replacing the A1–A3 and Other Front Panel Subassemblies”](#) on page 7-10.

Table 4-2 Front Panel Keyboard Key Names

TRACE/CHAN Keys	RESPONSE Keys	ENTRY Keys	ENTRY Keys (Cont'd)
Trace 1	Meas	OK	k/m
Trace 2	Format	Cancel	Enter Off
Trace 3	Scale	Help	. (decimal point)
Trace 4	Display	Bk Sp	+/-
Traces	Avg	0	STIMULUS Keys
Receiver	Cal	1	Freq
Navigation Keys	MARKER/ ANALYSIS Keys	2	Power
←	Marker	3	Sweep
→	Search	4	Trigger
↑	Memory	5	UTILITY Keys
↓	Analysis	6	Save
Click		7	Print
		8	Macro
		9	Recall
		G/n	System
		M/u	Preset

Checking the RPG (Front Panel Knob)

To check the RPG knob:

1. Press the UTILITY **Preset** key.
1. Rotate the knob and check for a fluid movement of numbers on the analyzer display.
 - If the movement of numbers is not smooth or no numbers appear at all, suspect a faulty A1 front panel interface board. To replace the A1 front panel interface board, refer to [“Removing and Replacing the A1–A3 and Other Front Panel Subassemblies”](#) on page 7-10.

A3 Display Test

The display should be bright with all annotations and text readable. The display test allows you to check for non-functioning pixels and other problems.

NOTE If the display is dim or dark, refer to [“Troubleshooting LCD Display Problems”](#) on page 4-12.

What Is a Damaged Pixel?

A pixel is a picture element that combines to create the image on the display. A pixel is about the size of a small pin point.

A damaged pixel is a pixel that has a constant blue, green, black, or red appearance that will not change.

How to Run the Display Test

To run the display test, perform the following:

Press UTILITY **System** , then **Service** , then **More** , then **Display Test** .

A multi-color screen is displayed. Be prepared to look for the symptoms described in [“How to Identify a Faulty Display.”](#) Follow the instructions on the screen.

How to Identify a Faulty Display

A display is considered faulty if:

- More than 0.002% of the total pixels have a constant blue, green, red, or black appearance that will not change.
- Three or more consecutive pixels have a constant blue, green, red, or black appearance that will not change.
- If the A3 display assembly is determined to be faulty, replace it. Refer to [“Removing and Replacing the A1–A3 and Other Front Panel Subassemblies”](#) on page 7-10.

Checking the A2 USB Board

To verify proper operation of the USB board:

- Connect a known good USB device, such as a USB mouse, to a front panel USB port.
- Wait 15 seconds for the analyzer to verify the device connection, and then check the operation of the USB device.
- If the device performs correctly, the USB board is functioning properly.
- If the device does not perform correctly, the USB board is faulty. Refer to [“Removing and Replacing the A1–A3 and Other Front Panel Subassemblies” on page 7-10.](#)

A1 Front Panel Interface Board

This assembly performs the following functions:

- It routes USB signals between the front-panel USB connector and the A21 CPU board.
- The speaker produces the audio output from signals supplied by the A21 CPU board.
- It routes key pad commands from the keypad to the A21 CPU board.
- It routes display signals from the A21 CPU board to the A3 display assembly.

Checking the Speaker

If no audio is heard:

- Verify that the volume is set correctly and the proper sound driver is loaded; do the following:
 - Press UTILITY **System**, then **Configure**, then **Control Panel...**.
- Click on the **Sounds and Audio Devices** entry. Follow the normal Windows procedure to check the sound drivers and volume. If the audio is still not heard, suspect a faulty speaker. Refer to [“Removing and Replacing the A1–A3 and Other Front Panel Subassemblies” on page 7-10.](#)

Checking the Operation of the Key Pad Commands

To verify the key pad functionality, refer to [“Front Panel Keypad and RPG Test” on page 4-13.](#)

Checking the Display

To verify the display functionality, refer to [“A3 Display Test” on page 4-15.](#)

Rear Panel Troubleshooting

Each rear panel connector is associated with a hardware group in the analyzer. You can use the data at these rear panel connectors to help troubleshoot these hardware groups in addition to testing the connectors.

The connectors discussed in this section are:

- USB x 4
- Monitor (VGA)
- GPIB (0) CONTROLLER
- GPIB (1) TALKER/LISTENER
- LAN

Checking the USB Ports

To verify proper operation of any rear panel USB port:

- Connect a known good USB device, such as a USB mouse.
- Wait 15 seconds for the analyzer to verify the device connection, and then check the operation of the USB device.
- If the device performs correctly, the USB port is functioning properly.
- If the device does not perform correctly, remove the non-working USB device, wait 15 seconds, and then reconnect the device to the rear panel USB port.
- If the USB device still does not work and has been verified to work elsewhere, then the A21 CPU board is faulty. Refer to ["Removing and Replacing the A21 CPU Board Assembly" on page 7-22](#).

Checking the CONTROLLER Port

The network analyzer uses a National Instruments 488.2 GPIB controller and associated driver software. This software includes a test utility that scans the GPIB bus and returns the status of all the connected peripherals.

To run the test utility software and check the GPIB status:

1. Connect a known good peripheral to the analyzer using a known good GPIB cable.
2. Press UTILITY **System**, then **Configure**, then **SICL/GPIB...**. A **SICL/GPIB/SCPI** dialog box is displayed.
3. In the **GPIB** block, click **System Controller** to establish the analyzer as a controller. Wait for the analyzer to configure, and then click **OK**.
4. If the Window Desktop is not displayed, press UTILITY **System**, then **Configure**, then **Control Panel...** to view the **Windows Taskbar** menu at the bottom of the display.
5. On the **Windows Taskbar** menu, click **Start** then point to **Programs, National Instruments NI-488.2**, and then click **Explore GPIB** to open the **Measurement & Automation** window.

6. On the left side of the **Measurement & Automation** window under folders:
 - a. Click the plus sign to expand the **Measurement & Automation** folder.
 - b. Click the plus sign to expand the **Devices and Interfaces** folder.
 - c. Right click **GPIB0 (AT-GPIB/TNT)** to open a submenu.
7. On the submenu, click **Scan for Instruments** to run the test.
8. The state of all the peripherals found on the bus is returned.
9. If problems are detected, check the connections of all GPIB cables, and check all the GPIB addresses of the instruments on the bus.

NOTE**Address Information**

- Each device must have its own unique address.
- The network analyzer's default GPIB address in the controller mode is 21.
- The address set on each device must match the one recognized by the analyzer (and displayed).

Refer to the manual of the peripheral to read or change its address.

Troubleshooting Systems with Controllers

Passing the preceding test indicates that the analyzer's peripheral functions are operating normally. Therefore, if the analyzer has not been operating properly with an external controller, check the following:

- The GPIB interface hardware is incorrectly installed or not operational. (Refer to the embedded help in your analyzer.)
- The programming syntax is incorrect. (Refer to the embedded help in your analyzer.)

LAN Troubleshooting

Problems with the Local Area Network (LAN) can be difficult to solve. Software and protocol problems can make it difficult to determine whether the analyzer's hardware is working properly, or if there is a problem with the LAN or cabling.

The purpose of this section is to determine if the analyzer's hardware is functioning properly. While the turn-on self-test verifies some LAN hardware functionality, it is limited to internal testing only. Incorrect IP addresses will prevent proper operation. Improper subnet masks may allow only one-way communication, while improper gateway addresses may exclude outside LAN access.

Ping Command

The analyzer has the built-in capability of performing a “ping” operation. Ping will request the analyzer to send a few bytes of information to a specific LAN device. That device will then signal the analyzer that it has received the information. The analyzer computes the approximate round trip time of the communication cycle and displays it. For a full test of two-way communications, a ping test should be performed in two directions.

- **First:** you should ping from the analyzer to the local area network.
- **Second:** you should ping from the local area network to the analyzer.

NOTE In the second case, any other network device capable of sending a ping command could be used, assuming it is connected to the same network. This could be a computer or even another analyzer.

How to Ping from the Analyzer to the Local Area Network (LAN)

Follow the steps below to verify proper LAN operation (assuming you have a functioning LAN). If no network LAN is available, see [“Testing Between Two Analyzers” on page 4-20](#).

1. Make sure the IP address on the analyzer is set properly and that it is unique. If unsure how to check the IP address, refer to the embedded help in the analyzer.
2. Make sure the subnet mask is 0.0.0.0. If not, note the current setting (to allow setting it back later) and then set it to 0.0.0.0.
3. Find and note the IP address of another working LAN device on the same network. Make sure this device is turned on, connected, and is functioning properly.
4. To ping the network device:
 - a. If the Windows Desktop is not displayed, press UTILITY **System**, then **Configure**, then **Control Panel...** to view the **Windows Taskbar** menu at the bottom of the display.
 - b. On the **Windows Taskbar** menu, click **Start**, point to **Programs, Accessories**, and then click **Command Prompt**.
 - c. The command prompt window is displayed.
 - d. At the prompt, type ping xxx.xxx.xxx.xxx¹ and press ENTRY **Enter** on the front panel. Refer to Step 5 for the results of a successful ping.
5. The analyzer attempts four cycles of communications with the indicated LAN device.
 - It displays the time it took to complete each cycle.
 - Each cycle times-out after one second if no communication is established and the message, Request timed out, is displayed.
 - It is common for the first of the four cycles to time-out even though subsequent cycles pass.
 - See below for an example output of a successful ping.

```
C:>ping 141.121.69.162
```

-
1. The letters x represent the IP address of the other device on the network.

Pinging 141.121.69.162 with 32 bytes of data:

```
Reply from 141.121.69.162: bytes=32 time<10ms TTL=127
Reply from 141.121.69.162: bytes=32 time<10ms TTL=127
Reply from 141.121.69.162: bytes=32 time<10ms TTL=127    Reply from 141.121.69.162: bytes=32
time<10ms TTL=127
```

Ping statistics for 141.121.69.162:

Packets: Sent = 4, Received = 4, lost = 0 <0% loss>.

Approximate round trip times in milli-seconds:

Minimum = 0ms, Maximum = 0ms, Average = 0ms

6. The above message verifies that one way communication from the analyzer to the network has been established
7. If the subnet mask was changed in step 2, set it back at this time.

How to Ping from the Local Area Network (LAN) to the Analyzer

Reverse communication should also be verified. Determining this, though, is dependent upon your network setup and software. Generally, you need to issue a ping command using the IP address of the analyzer to be tested. For example, using Windows 95, 98, 2000, XP or 7, and while at a DOS prompt, type in ping xxx.xxx.xxx.xxx¹. Then press ENTRY on the front panel. If full communication can be established, then the computer display shows the cycle time for each of four cycle attempts (similar to that in step 5). Other software may behave somewhat differently, but basically the same.

If the analyzer can talk to the network, but the network can not talk to the analyzer, then the computer or device used from the network may have a subnet mask that excludes communication with the IP address chosen for the analyzer. Any subnet mask other than 0.0.0.0 will exclude operation from some addresses. Changing the subnet mask of a computer or other device should only be attempted by a qualified network administrator. Failure to communicate due to a subnet mask incompatibility does not indicate any failure of the analyzer.

If the analyzer fails to ping in either direction, and assuming the subnet masks are set properly, then the fault must be isolated to the analyzer or to the network. Contact a qualified network administrator.

Testing Between Two Analyzers

The ability of the analyzer's LAN to function can be easily tested by connecting two analyzers together using a "crossover cable" (a short length of cable with an RJ-45 connector on each end).

Some network hubs have the capability to make a crossover connection using two normal, or straight-through, cables. If this capability is not available and a crossover cable is not available, a crossover cable can be made by following the directions in "[Constructing a Crossover Cable](#)" on page 4-21.

Set the IP addresses on two analyzers. The addresses can be set to anything, but they must be different. Make sure the subnet mask and gateway addresses are set to 0.0.0.0 and that the LAN is active on both analyzers. Connect the two analyzers together using either a crossover cable or a crossover hub.

Now follow the steps in "[How to Ping from the Analyzer to the Local Area Network \(LAN\)](#)" on page 4-19 to have the first analyzer ping the second analyzer. When done, repeat the procedure having the second analyzer ping the first. If both procedures function properly, the LAN circuitry on both analyzers is verified.

1. The letters x represent the IP address of the analyzer.

If neither function properly:

- One or both IP addresses could be wrong.
- One or both LAN states could be set to off.
- The crossover cable could be miswired.
- One or both analyzers could be defective.

If possible, eliminate the possibility of a defective analyzer by substitution of a known working unit. Once the analyzer has been proven to be working properly, concentration can be placed on the network itself to determine the cause of the failure.

Constructing a Crossover Cable

A crossover cable can be made from a standard LAN cable by connecting pin 1 from each connector to pin 3 of the other connector, and pin 2 from each connector to pin 6 of the other connector.

1. Strip away a few inches of the outside jacket insulation from the middle of a standard LAN cable that has an RJ-45 connector on each end.

NOTE Pins 1, 2, 3, and 6 of the connectors must be located to determine which wires to cut in the following steps. Most, but not all, LAN cables use the color coding listed in [Table 4-3](#). If your cable does not use this color scheme, you will have to determine the locations of the appropriate wires before proceeding with this procedure.

Table 4-3 LAN Pin Definitions and Wire Color Codes

Pin Number	Color	Pin Number	Color
1 (transmit +)	White/orange	5	White/blue
2 (transmit -)	Orange	6 (receive -)	Green
3 (receive +)	White/green	7	White/brown
4	Blue	8	Brown

2. Cut the wires going to pins 1, 2, 3, and 6. Strip away a small amount of insulation from each of the eight cut ends.
 - a. Connect the wire from pin 1 on one end of the cable to the wire from pin 3 on the other end of the cable.
 - b. Connect the wire from pin 3 on one end of the cable to the wire from pin 1 on the other end of the cable.
 - c. Connect the wire from pin 2 on one end of the cable to the wire from pin 6 on the other end of the cable.
 - d. Connect the wire from pin 6 on one end of the cable to the wire from pin 2 on the other end of the cable.
3. Insulate all exposed wires so that they cannot short together.
4. Label this as a crossover cable so that it cannot be confused with a standard cable.

Figure 4-5 Construction of a Crossover Cable

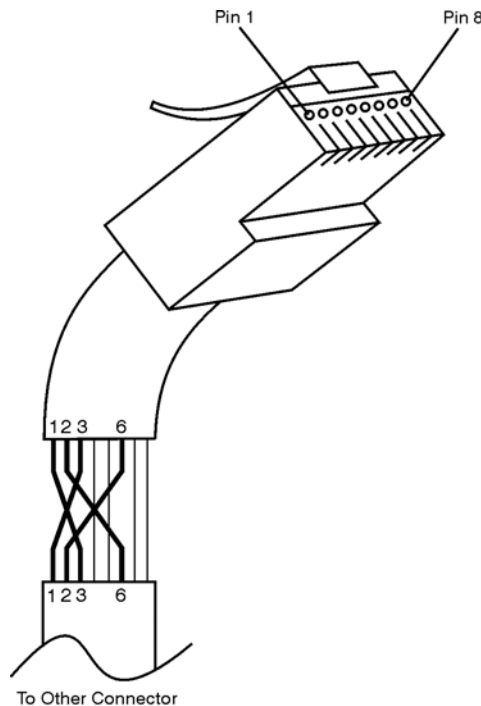

sd623c

Measurement System Troubleshooting

This section provides troubleshooting procedures for the measurement portion of the PNA. In this section, the analyzer is used as a tool to help isolate the suspected faulty functional group. Once the faulty functional group is determined, troubleshooting steps are provided to help you isolate the faulty assembly or part.

IMPORTANT Some procedures in this chapter reference your analyzer's DSP version. Click **Help > About Network Analyzer** and note the DSP version shown.

Before you begin—consider: Where do you see a problem?

If you are seeing a problem at **Preset**, perform the standard S-parameter test set troubleshooting procedure, starting with: [“Verifying the A, B, C, D, and R Traces \(Standard S-Parameter Mode\)” on page 4-26.](#)

You should also consider the problem indications that are observed and whether the observed condition is a soft failure or a hard failure.

Soft Failure

With a *soft* failure, the network analyzer's performance has degraded to an unacceptable level, yet it continues to operate and displays no error messages. For this type of failure, performance tests must be conducted to isolate the problem. Begin with viewing the error terms as described in [“Error Terms” on page 8-3.](#) This will help to isolate most problems. If additional tests are required, refer to [“Performance Tests” on page 3-28.](#)

Hard Failure

With a *hard* failure, the PNA does not perform well and displays one or more error messages. To diagnose and repair a hard failure:

- Check [“Help About”](#) to verify that the model number and options listed match the actual analyzer model and options.
- Check [“EEPROM Headers”](#) to verify that the data there is correct.
- Check error messages. Refer to [“Error Messages”](#) and follow the suggestions outlined there for each applicable error message.

Help About

Go to the Help About screen by pressing UTILITY **System**, then **Help**, then **About NA...**. Verify that the information displayed in this screen is correct for your analyzer. If any of the information is incorrect, contact Keysight Technologies. Refer to [“Contacting Keysight” on page 2-8.](#)

EEPROM Headers

The network analyzer application uses the firmware revision information stored in the PC board header EEPROM. If the information stored in any EEPROM is incorrect, the network analyzer may not operate properly.

The following table lists the PC boards in your network analyzer that contain EEPROM headers. The PC boards are listed by name and part number and the correct firmware revision code is given for each.

PC Board Name	PC Board Part Number	Hardware ID	Firmware Revision
SPAM	N5240-60077 Was N5240-60056	A16	
13.5 GHz LO Synthesizer	N5240-60074 Was N5242-60150	A15	
Test Set Motherboard	N5247-60001	A23	
IF Multiplexer	N5240-60062	A24	
Frequency Reference	N5240-60069 Was N5240-60061	A14	
26.5 GHz Source 2	5087-7342	A10	
13.5 GHz source 2 synthesizer	N5240-60074 Was N5242-60150	A17	
13.5 GHz source 1 synthesizer	N5240-60074 Was N5242-60150	A4	
26.5 GHz Source 1	5087-7342	A5	
GPIB	N5240-60059	A22	

To view this EEPROM header information on the network analyzer display: press UTILITY **System** , then **Service** , then **Utilities** , then **View EEPROM Headers** . Refer to **Figure 4-6**.

If the information is incorrect for any of the PC boards, contact Keysight Technologies. Refer to **“Contacting Keysight”** on page 2-8.

Figure 4-6 EEPROM Header Info Dialog Window

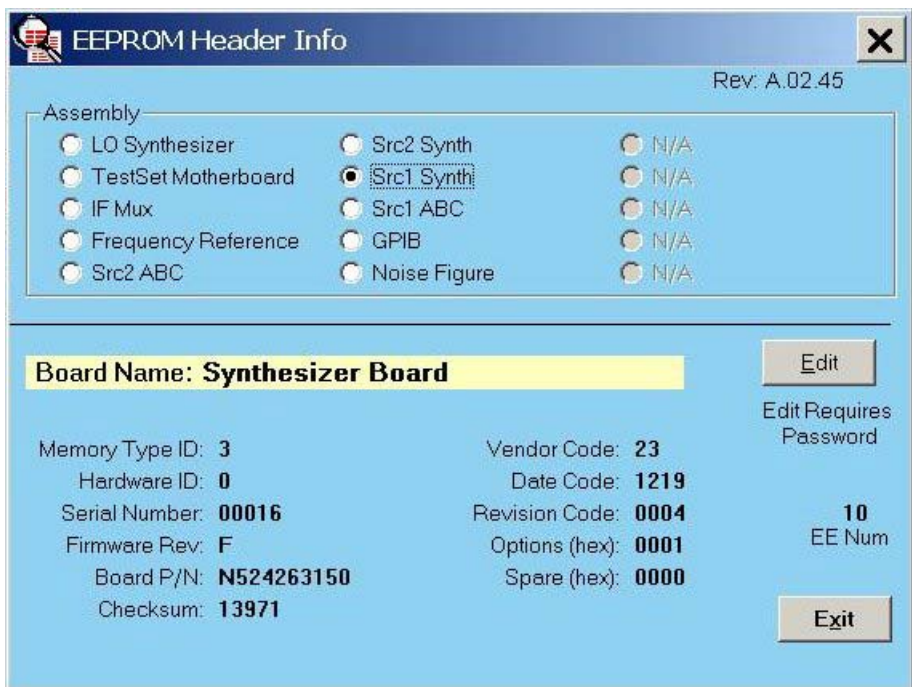

Error Messages

SOURCE UNLEVELED: The source ALC circuit on the A23 test set motherboard is running open-loop. Check the cable connections for the A25 HMA26.5 and the A23 test set motherboard.

Verifying the A, B, C, D, and R Traces (Standard S-Parameter Mode)

The first step is to verify that the A, B, C, D, and R traces are present and that they are approximately level:

- Connect an Open or Short standard from a mechanical calibration kit to each test port (use adapters if necessary).
- Press UTILITY **System**, then **Service**, then **Utilities**, then **Receiver Display**.
- For 2-port analyzer models, traces A, B, R1, and R2 are displayed in four separate data windows as shown in **Figure 4-7**. Identifying discrepancies of the traces in these windows can help you to isolate the faulty assembly.

Figure 4-7 Typical 4-Receiver Display for 2-Port Models

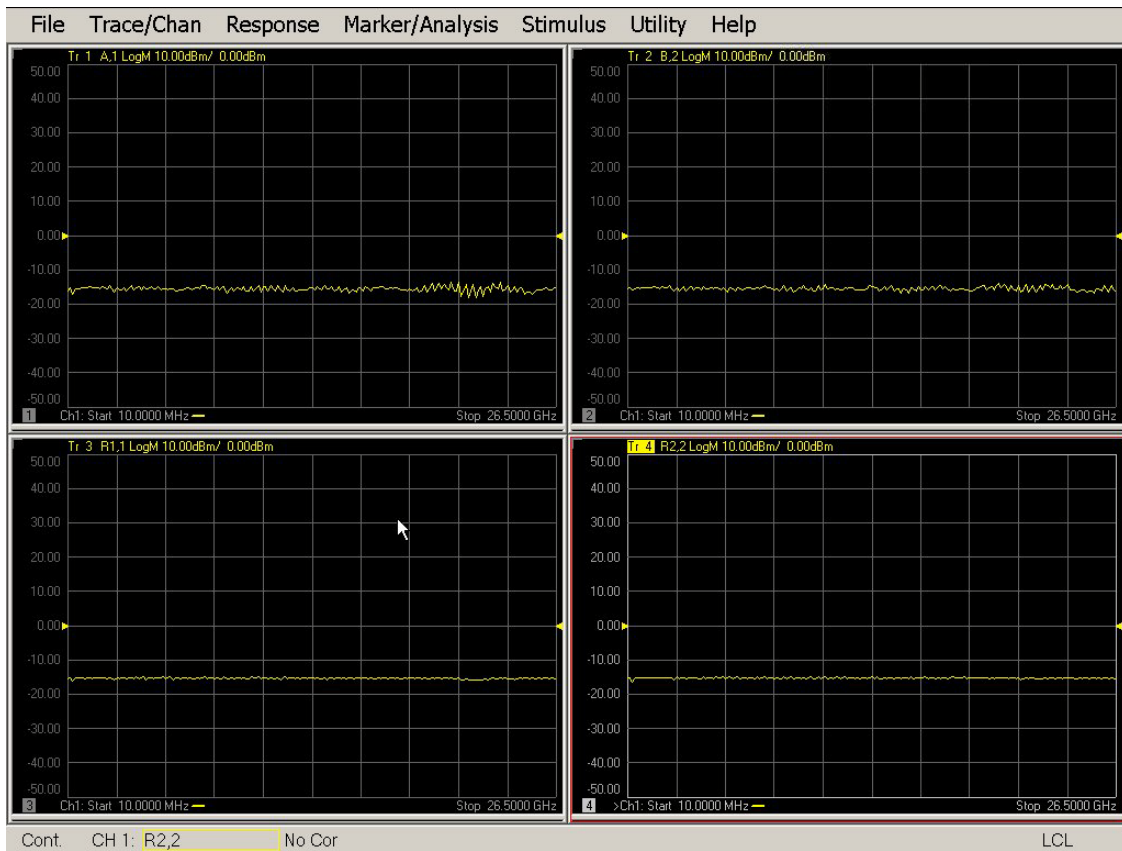

- For 4-port analyzer models, traces A, B, C, D, and R1, R2, R3, and R4 are displayed in eight separate data windows as shown in [Figure 4-8](#). Identifying discrepancies of the traces in these windows can help you to isolate the faulty assembly.

Figure 4-8 Typical 5-Receiver Display for 4-Port Models

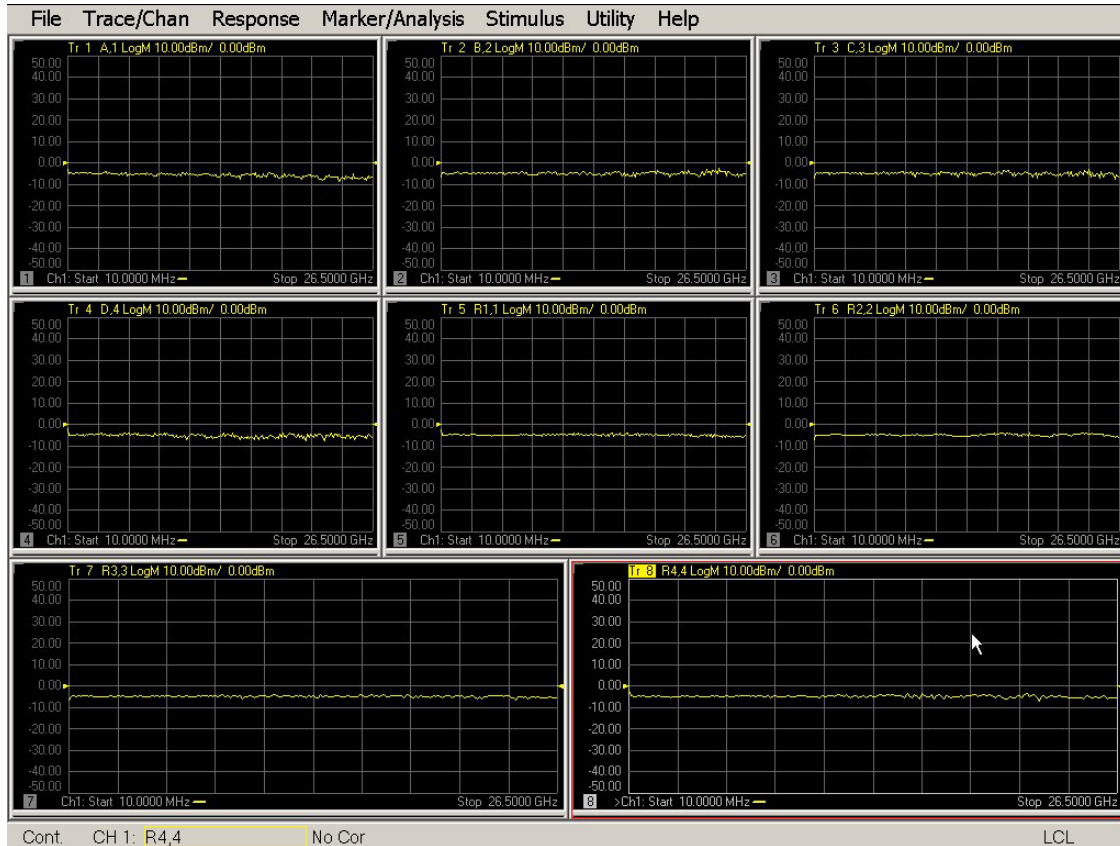

- If all traces are present and are similar to the traces in [Figure 4-7](#) or [Figure 4-8](#), then there are no major problems with the analyzer’s measurement system. There may, however, be a minor failure in the analyzer.
To test further:
 - Go to [Chapter 3, “Tests and Adjustments”](#) and perform all the tests in that section.
 - If a problem still exists, contact Keysight. Refer to [“Contacting Keysight” on page 2-8](#).
- If any of the traces are not present, are noisy or distorted, or are at an incorrect level, then there is a problem with the analyzer’s measurement system. Proceed to [“Where to Begin Troubleshooting.”](#)

Where to Begin Troubleshooting

For the purposes of troubleshooting, the analyzer block diagram is divided into the following functional groups:

- **the source and LO group**
 - A14 frequency reference
 - A4 and A17 13.5 GHz source synthesizers
 - A5 and A10 sources
 - A15 13.5 GHz LO synthesizer
 - A25 HMA26.5
 - A26 splitter
 - A23 test set motherboard
- **the signal separation group**
 - A29, A30, A31, and A32 receiver couplers
 - A38, A39, A40, and A41 60-dB source step attenuators
 - A42, A43, A44, and A45 60-dB bias tees
 - A33, A34, A35, and A36 test port couplers
 - A23 test set motherboard
- **the receiver group**
 - A37 reference mixer switch
 - A46, A47, A48, and A49 35-dB receiver step attenuators
 - A27 and A28 mixer bricks
 - A16 SPAM board
 - A24 IF multiplexer board
 - A23 test set motherboard

Use the list on the following pages to help you determine in which analyzer functional group to begin troubleshooting.

This is by no means an exhaustive list of possible symptoms nor possible failures. It is recommended that you view the system block diagram, at the end of this chapter, as you review the entries in this list and perform any of the troubleshooting procedures listed.

Good judgment and established logical troubleshooting techniques must be used to complement the procedures contained in this section.

All Traces

- **If all traces are missing in all bands**, the problem is most likely in the source group. However, a missing or disabled DSP driver may exhibit the same or similar symptoms. To verify that this DSP driver is present and enabled:
 1. Press UTILITY **System**, then **Configure**, then **Control Panel...**. In the **Address** box, click the down arrow and then click **My Computer**. In an open area of the My Computer window, click the right mouse button and then click **Properties** in the resulting pop-up menu.

Click the **Hardware** tab, click **Device Manager**, and then expand **Keysight PNA DSP Device** in the resulting list. The following entry should be listed: **Keysight Technologies DSP Driver #2** and should be enabled.
 2. If the entry is not present or if the icon to the left of the name is a yellow box containing an exclamation mark (!), navigate the following directories and verify the presence of the following file:
C:\WINNT\system32\drivers\spampnp.sys.
 3. If you have verified that the DSP driver is present and enabled, but all traces are still missing in all bands, go to [“Checking the Source Group” on page 4-30](#).
- **If the traces exhibit power drops in some frequency bands**, the problem is in the source group. Go to [“Source Group Tests” on page 4-30](#) and perform the tests that correspond to the problems seen.

Single Trace (A, B, C, D, R1, R2, R3, or R4) Only

If the trace is missing in all bands or has notches or roll-off, go to [“Checking the Signal Separation Group” on page 4-35](#).

A, B, R1, and R2 Traces Only

The problem is in the source 1 group, go to [“Checking the Source Group” on page 4-30](#).

C, D, R3, and R4 Traces Only

The problem is in the source 2 group, go to [“Checking the Source Group” on page 4-30](#).

Checking the Source Group

Source Group Tests

Before checking the source group assemblies, you must open the analyzer.

CAUTION Use an antistatic work surface and wrist strap to reduce the chance of electrostatic discharge for all of the procedures in this chapter.

1. Turn off the analyzer power.
2. Unplug the power to the analyzer and disconnect all front and rear panel connections except installed jumpers.
3. Remove the outer and inner covers from the analyzer. Refer to ["Removing the Covers" on page 7-6](#).

WARNING Procedures described in this document are performed with power supplied to the product while protective covers are removed. Energy available at many points may, if contacted, result in personal injury.

4. With the covers off, plug in the analyzer and turn on the power.

CAUTION Do not operate the analyzer with the outer cover removed for more than 30 minutes, as this could cause the analyzer to overheat which could result in costly damage.

Frequency Banded vs. Broadband Failure

There are two main types of failures that are related to the source group. Frequency banded failures are indicated by all receiver traces having partial dropouts across the frequency range. Broadband failures are indicated by all receiver traces being in the noise floor.

RF Signal Troubleshooting

Check the output power of the A, B, C, and D signals:

Equipment Used for This Check

Equipment Type	Model or Part Number	Alternate Model or Part Number
Power meter	E4418B/E4419B	E4418A/E4419A
Power sensor, 2.4 mm	E8487A	None
Adapter, 2.4 mm (f) to 2.4 mm (f)	11900B	85056-60007

Equipment Setup

1. Before starting these checks, zero and calibrate the power meter. (See the power meter user's guide for instructions on setting the calibration factor.)
2. If the **Receiver Display** (Figure 4-7 or Figure 4-8) is not on the analyzer screen, perform the following:
Press UTILITY **System**, then **Service**, then **Utilities**, then **Receiver Display**.
3. Set the sweep speed for a 10 second sweep: Press STIMULUS **Sweep**, then **Sweep Time**. Set the time to 10.000 seconds in the **Sweep Time** box.

To isolate a broadband RF signal generation failure, check the test port output power:

4. Note the power reading displayed on the power meter; it should be the preset power level +/- 1 dB.
5. Connect the power sensor, in turn, to Ports 2, 3, and 4 and set trace to measure S_{22} , S_{33} , and S_{44} respectively. Note the power reading displayed on the power meter.
 - If the power level is low or high on all test ports, the problem is LO signal related. Continue with **"Checking the A14 50 MHz Reference Outputs"**.
 - If the power level is low or high on only one of the test ports, the problem is either source group or in the signal separation group. Continue with **"Checking the A14 50 MHz Reference Outputs"** to check the source group.

Checking the A14 50 MHz Reference Outputs

1. Refer to the block diagram at the end of this chapter and to **"Top Assemblies and Cables, All Options"** on page 6-16. Locate flexible cables W75, W76, and W77, at the A14 frequency reference board.
2. Disconnect cables W75, W76, and W77, one at a time, from the A14 board.
3. Connect the spectrum analyzer to the open connector on the A14 board.
4. The spectrum analyzer should measure a signal at 50 MHz.
5. If any of the 50 MHz signals are not present, replace the A14 frequency reference board. Refer to **"Removing and Replacing the A4–A17 Boards"** on page 7-14.
6. If the 50 MHz signals are present, reconnect the cables, and then:
 - for LO related problems, continue testing at **"Checking the A15 13.5 GHz LO Synthesizer Output"**.
 - for source related problems, continue testing at **"Checking the A4 and A17 Source Synthesizer Outputs"** on page 4-33.

Checking the A15 13.5 GHz LO Synthesizer Output

1. Refer to the block diagram at the end of this chapter and to **"Top Assemblies and Cables, All Options"** on page 6-16. Locate the flexible cable W51 at the A15 LO synthesizer board.
2. Disconnect W51 from J1207.
3. Connect the spectrum analyzer to J1207.
4. Refer to **the IMPORTANT notice on page 4-23**. Set the network analyzer for an 800 MHz CW frequency and observe the spectrum analyzer measurement. For analyzers with DSP version 4.0, an 807.61 MHz signal should be present. For analyzers with DSP version 5.0, an 807.44 MHz signal should be present.

5. If the observed problem was frequency banded rather than broadband related, set the analyzer frequency to the center of the problem band. The spectrum analyzer should measure a signal above the network analyzer setting. For analyzers with DSP version 4.0, the signal is 7.61 MHz above the network analyzer setting. For analyzers with DSP version 5.0, the signal is 7.44 MHz above the network analyzer setting.
6. If the LO signal is not present but the 50 MHz reference signal from [“Checking the A14 50 MHz Reference Outputs”](#) is present, replace the A15 LO synthesizer board. Refer to [“Removing and Replacing the A4–A17 Boards”](#) on page 7-14.
7. If the signal is present, reconnect cable W41, and then continue with [“Checking the A25 HMA26.5 Output”](#).

Checking the A25 HMA26.5 Output

1. Refer to the block diagram at the end of this chapter and to [“Bottom Assemblies, Standard 4-Port Configuration, Option 400”](#) on page 6-52. Locate the flexible cable W52 at the A25 HMA26.5.
2. Disconnect W52 (4-port models) or W80 (2-port models) from the A25 HMA 26.5.
3. Connect the spectrum analyzer to the open connector on the A25 HMA 26.5.
4. Refer to [the IMPORTANT notice on page 4-23](#). Set the network analyzer for an 800 MHz CW frequency and observe the spectrum analyzer measurement. For analyzers with DSP version 4.0, an 807.61 MHz signal should be present. For analyzers with DSP version 5.0, an 807.44 MHz signal should be present.
5. If the observed problem was frequency banded rather than broadband related, set the analyzer frequency to the center of the problem band. The spectrum analyzer should measure a signal above the network analyzer setting. For analyzers with DSP version 4.0, the signal is 7.61 MHz above the network analyzer setting. For analyzers with DSP version 5.0, the signal is 7.44 MHz above the network analyzer setting.
6. If the signal is not present but the signal from [“Checking the A15 13.5 GHz LO Synthesizer Output”](#) is present, replace the A25 HMA 26.5. Refer to [“Removing and Replacing the A25 HMA26.5”](#) on page 7-30.
7. If the signal is present, reconnect cable W52 or W80 and then:
 - for 2-port models, continue checking with [“Checking the Receiver Group”](#) on page 4-39.
 - for 4-port models, continue checking with [“Checking the A26 Splitter Output”](#).

Checking the A26 Splitter Output

1. Refer to the block diagram at the end of this chapter and to [“Bottom RF Cables, Standard 4-Port Configuration, Option 400”](#) on page 6-54. Locate the semi-rigid cables W53 and W54, at the A26 splitter.
2. Disconnect W53 and W54, one at a time, from the A26 splitter.
3. Connect the spectrum analyzer to the open connector.
4. Refer to [the IMPORTANT notice on page 4-23](#). Set the network analyzer for an 800 MHz CW frequency and observe the spectrum analyzer measurement. For analyzers with DSP version 4.0, an 807.61 MHz signal should be present. For analyzers with DSP version 5.0, an 807.44 MHz signal should be present.
5. If the observed problem was frequency banded rather than broadband related, set the analyzer frequency to the center of the problem band. The spectrum analyzer should measure a signal above the network analyzer setting. For analyzers with DSP version 4.0, the signal is 7.61 MHz above the network analyzer setting. For analyzers with DSP version 5.0, the signal is 7.44 MHz above the network analyzer setting.
6. If the signal is not present but the signal from [“Checking the A25 HMA26.5 Output,”](#) is present, replace

the A26 splitter. Refer to [“Removing and Replacing the A26 Splitter”](#) on page 7-32.

7. If the signal is present, reconnect cables W53 and W54, and then continue with [“Checking the Receiver Group”](#) on page 4-39.

Checking the A4 and A17 Source Synthesizer Outputs

1. Refer to the block diagram at the end of this chapter and to [“Top Assemblies and Cables, All Options”](#) on page 6-16. Locate either the cable W1 at the A4 source 1 synthesizer board or W2 at the A17 source 2 synthesizer board. (W2 and A17 are only available in 4-port models and 2-port models with Option 224.)
2. Disconnect W1 or W2 from J1207.
3. Connect the spectrum analyzer to J1207.
4. Set the network analyzer for an 800 MHz CW frequency and observe the spectrum analyzer measurement. An 800 MHz signal should be present.
5. Refer to [the IMPORTANT notice on page 4-23](#). If the observed problem was frequency banded rather than broadband related, set the analyzer frequency to the center of the problem band. The spectrum analyzer should measure a signal above the network analyzer setting. For analyzers with DSP version 4.0, the signal is 7.61 MHz above the network analyzer setting. For analyzers with DSP version 5.0, the signal is 7.44 MHz above the network analyzer setting.
6. If the signal is not present but the 50 MHz reference signal from [“Checking the A14 50 MHz Reference Outputs”](#) is present, replace the faulty synthesizer board. Refer to [“Removing and Replacing the A4–A17 Boards”](#) on page 7-14.
7. If the signal is present, reconnect cables W1 and W2, and then continue with [“Checking the A5 and A10 Source Outputs”](#).

Checking the A5 and A10 Source Outputs

1. Refer to the block diagram at the end of this chapter and to [“Top Assemblies and Cables, All Options”](#) on page 6-16. Locate the cables W3 and W4 at the A5 source 1 board or cables W7 and W8 at the A10 source 2 board. (W7, W8, and A10 are only available in 4-port models and 2-port models with Option 224.)
2. Disconnect cables W3 and W4 or cables W7 and W8, dependent on which source board is to be checked, at the A7, A8, A12, or A13 50 GHz Doubler board.
3. Connect the spectrum analyzer to the open connector at the end of the cable that connects to the source board to be checked.
4. Set the network analyzer for an 800 MHz CW frequency and observe the spectrum analyzer measurement. An 800 MHz signal should be present.
5. Refer to [the IMPORTANT notice on page 4-23](#). If the observed problem was frequency banded rather than broadband related, set the analyzer frequency to the center of the problem band. The spectrum analyzer should measure a signal above the network analyzer setting. For analyzers with DSP version 4.0, the signal is 7.61 MHz above the network analyzer setting. For analyzers with DSP version 5.0, the signal is 7.44 MHz above the network analyzer setting.
6. If the signal is not present but the signals from [“Checking the A4 and A17 Source Synthesizer Outputs”](#) are present, replace the appropriate source board. Refer to [“Removing and Replacing the A4–A17 Boards”](#) on page 7-14.

7. If the signal is present, reconnect all cables, and then continue with [“Checking the A7, A8, A12, and A13 50 GHz Doubler Outputs”](#).

Checking the A7, A8, A12, and A13 50 GHz Doubler Outputs

1. Refer to the block diagram at the end of this chapter and to [“Top Assemblies and Cables, All Options” on page 6-16](#). Locate cable W11 on the A7 doubler board, cable W17 on the A8 doubler board, cable W13 on the A12 doubler board, and cable W15 on the A13 doubler board. (A12 and A13 are only available in 4-port models and 2-port models with Option 224.)
2. Disconnect cable W11 or W17 or W13 or W15, dependent on which doubler board is to be checked.
3. Connect the spectrum analyzer to the open connector on the doubler board to be checked.
4. Set the network analyzer for an 800 MHz CW frequency and observe the spectrum analyzer measurement. An 800 MHz signal should be present.
5. Refer to [the IMPORTANT notice on page 4-23](#). If the observed problem was frequency banded rather than broadband related, set the analyzer frequency to the center of the problem band. The spectrum analyzer should measure a signal above the network analyzer setting. For analyzers with DSP version 4.0, the signal is 7.61 MHz above the network analyzer setting. For analyzers with DSP version 5.0, the signal is 7.44 MHz above the network analyzer setting.
6. If the signal is not present but the signals from [“Checking the A4 and A17 Source Synthesizer Outputs”](#) are present, replace the appropriate doubler board. Refer to [“Removing and Replacing the A4–A17 Boards” on page 7-14](#).
7. If the signal is present, reconnect all cables, and then continue with [“Checking the Signal Separation Group” on page 4-35](#).

Checking the Signal Separation Group

Before checking the signal separation group assemblies, you must open the analyzer.

CAUTION Use an antistatic work surface and wrist strap to reduce the chance of electrostatic discharge for all of the procedures in this chapter.

1. Turn off the analyzer power.
2. Unplug the power to the analyzer and disconnect all front and rear panel connections except installed jumpers.
3. Remove the outer cover from the analyzer. Refer to **“Removing the Covers”** on page 7-6.

WARNING Procedures described in this document are performed with power supplied to the product while protective covers are removed. Energy available at many points may, if contacted, result in personal injury.

4. With the covers off, plug in the analyzer and turn on the power.

CAUTION Do not operate the analyzer with the outer cover removed for more than 30 minutes, as this could cause the analyzer to overheat which could result in costly damage.

Checking the Output Power of the A, B, C, and D Signals

Using a power meter, you can measure the outputs of the A, B, C, and D signals from the front panel. The measurement results will help you isolate a faulty assembly. The output of the R receiver cannot be measured because it would necessitate breaking the phase lock loop, causing all of the signals to be lost.

Equipment Used for This Check

Equipment Type	Model or Part Number	Alternate Model or Part Number
Power meter	E4418B/E4419B	E4418A/E4419A
Power sensor, 2.4 mm	E8487A	None
Adapter, 2.4 mm (f) to 2.4 mm (f)	11900B	85056-60007

Equipment Setup

1. Before starting these checks, zero and calibrate the power meter. (See the power meter user’s guide for instructions on setting the calibration factor.)
2. If the **Receiver Display** (Figure 4-7 or Figure 4-8) is not on the analyzer screen, perform the following: Press UTILITY **System**, then **Service**, then **Utilities**, then **Receiver Display**.
3. Set the sweep speed for a 10 second sweep: Press STIMULUS **Sweep**, then **Sweep Time**. Set the time to 10.000 seconds in the **Sweep Time** box.

Checking Port 1, 2, 3, or 4 Power Outputs (A, B, C, or D Signals)

The object of this check is to verify the power of the output signal across the entire frequency range. Perform this test if there is an observed problem only with one receiver trace. The ten second sweep is slow enough to allow you to observe the output power on the power meter as the sweep occurs.

1. Connect the power sensor to the suspect port.
2. Set the trace to measure S_{11} , S_{22} , S_{33} , or S_{44} , dependent on the suspect port.
3. Observe the power reading on the power meter as the sweep occurs on the analyzer.
4. The measured output power on the power meter should be at least the preset power level ± 1 dB over the entire frequency range.
 - If the measured power is correct, go to [“Checking the Receiver Group” on page 4-39](#).
 - If the measured power is not correct, go to [“Checking the Signal through the Signal Separation Path” on page 4-36](#).

Checking the Signal through the Signal Separation Path

For all of the following checks, refer to the block diagrams at the end of this chapter and to any of the following that are appropriate:

- [“2-Port Configuration, Option 200” on page 6-22](#)
- [“Bottom RF Cables, Standard 2-Port Configuration, Option 200” on page 6-24](#)
- [“2-Port Configuration, Option 219” on page 6-46](#)
- [“Bottom RF Cables, 2-Port, Option 219” on page 6-48](#)
- [“4-Port Configuration, Option 400” on page 6-52](#)
- [“Bottom RF Cables, Standard 4-Port Configuration, Option 400” on page 6-54](#)
- [“4-Port Configuration, Option 419” on page 6-78](#)
- [“Bottom RF Cables, 4-Port, Option 419 \(Ports 1 and 2\)” on page 6-80](#)
- [“Bottom RF Cables, 4-Port, Option 419 \(Ports 3 and 4\)” on page 6-82](#)

Trace loss in the signal separation group is due to one or more of the following assemblies being defective:

- A29, A30, A31, or A32 receiver coupler
- A38, A39, A40, or A41 source step attenuator
- A42, A43, A44, or A45 bias tee
- A33, A34, A35, and A36 test port coupler

Equipment Used for These Tests

Equipment Type	Model or Part Number	Alternate Model or Part Number
Spectrum analyzer	8565E	856xE ^a

a. Must be capable of measuring a signal at 1 GHz.

To determine which assembly is defective, check the signal at each available measurement point in the signal path from the output of the source board to the output port.

Set the network analyzer for an S_{11} , S_{22} , S_{33} , or S_{44} , measurement for Port 1, 2, 3, or 4 respectively, with a CW frequency of 800 MHz.

Perform the following checks in the order presented.

Checking the A29, A30, A31, and A32 Receiver Couplers

1. Locate the appropriate semirigid cable at the output of the receiver coupler to be checked:
 - Options 200 and 400
 - Port 1; W19 of A29
 - Port 2; W31 of A32
 - Port 3; W23 of A30
 - Port 4; W27 of A31
 - Options 219 and 419
 - Port 1; W81 of A29
 - Port 2; W93 of A32
 - Port 3; W85 of A30
 - Port 4; W89 of A31
2. Using a 5/16-inch torque wrench, disconnect the semirigid cable at the receiver coupler.
3. Connect the spectrum analyzer to the open receiver coupler connector. Set the spectrum analyzer to measure a signal at 800 MHz.
4. If the 800 MHz signal is not present and the analyzer does not have mechanical switches, replace the receiver coupler. Refer to **“Removing and Replacing the A29–A32 Receiver Couplers and Receiver Coupler Mounting Brackets”** on page 7-36.
5. If the 800 MHz signal is present and the analyzer has source attenuators and bias tees, reconnect the cable to the receiver coupler and continue testing at **“Checking the A38, A39, A40, and A41 60-dB Source Step Attenuators”** on page 4-37
6. If the 800 MHz signal is present and the analyzer does not have source attenuators and bias tees, replace the test port coupler. Refer to **“Removing and Replacing the A33–A36 Test Port Couplers”** on page 7-38.

Checking the A38, A39, A40, and A41 60-dB Source Step Attenuators

1. Locate the appropriate semirigid cable at the output of the source step attenuator to be checked:

- Options 219 and 419
 - Port 1; W82 of A38
 - Port 2; W94 of A41
 - Port 3; W86 of A39
 - Port 4; W90 of A36
2. Using a 5/16-inch torque wrench, disconnect the semirigid cable at the step attenuator.
 3. Connect the spectrum analyzer to the open step attenuator connector. Set the spectrum analyzer to measure a signal at 800 MHz.
 4. If the 800 MHz signal is not present, replace the source step attenuator. Refer to [“Removing and Replacing the A38–A41 Source Attenuators and the A46–A49 Receiver Attenuators”](#) on page 7-42.
 5. If the 800 MHz signal is present, replace the associated bias tee. Refer to [“Removing and Replacing the A38–A41 Source Attenuators and the A46–A49 Receiver Attenuators”](#) on page 7-42.

Checking the Receiver Group

Equipment Used for These Tests

Equipment Type	Model or Part Number	Alternate Model or Part Number
Spectrum analyzer	8565E	856xE ^a

- a. Refer to the **IMPORTANT** notice on page 4-23. Must be capable of measuring a signal at 7.61 MHz (analyzers with DSP version 4.0), or 7.44 MHz (analyzers with DSP version 5.0), and 1 GHz.

For all of the following checks, refer to the block diagrams at the end of this chapter and to any of the following that are appropriate:

- “2-Port Configuration, Option 200” on page 6-22
- “Bottom RF Cables, Standard 2-Port Configuration, Option 200” on page 6-24
- “2-Port Configuration, Option 219” on page 6-46
- “Bottom RF Cables, 2-Port, Option 219” on page 6-48
- “4-Port Configuration, Option 400” on page 6-52
- “Bottom RF Cables, Standard 4-Port Configuration, Option 400” on page 6-54
- “4-Port Configuration, Option 419” on page 6-78
- “Bottom RF Cables, 4-Port, Option 419 (Ports 1 and 2)” on page 6-80
- “Bottom RF Cables, 4-Port, Option 419 (Ports 3 and 4)” on page 6-82

Getting Ready to Test

Before checking the assemblies, you must open the analyzer.

CAUTION Use an antistatic work surface and wrist strap to reduce the chance of electrostatic discharge for all of the procedures in this chapter.

1. Turn off the analyzer power.
2. Unplug the power to the analyzer and disconnect all front and rear panel connections except installed jumpers.
3. Remove the outer and inner covers from the analyzer. Refer to “Removing the Covers” on page 7-6.

WARNING Procedures described in this document are performed with power supplied to the product while protective covers are removed. Energy available at many points may, if contacted, result in personal injury.

4. With the covers off, plug in the analyzer and turn on the power.

CAUTION Do not operate the analyzer with the outer cover removed for more than 30 minutes, as this could cause the analyzer to overheat which could result in costly damage.

Checking the A27 and A28 Mixer Brick Receiver Outputs

Set the network analyzer for an S_{11} measurement with a CW frequency of 1 GHz.

1. Locate the following flexible cables at the receiver IF outputs of the mixer brick(s).
 - 2-port models
 - Receiver A; W61 of A27
 - Receiver R1; W62 of A27
 - Receiver R2; W63 of A27
 - Receiver B; W64 of A27
 - 4-port models
 - Receiver A; W61 of A27
 - Receiver R1; W62 of A27
 - Receiver R2; W63 of A27
 - Receiver B; W64 of A27
 - Receiver C; W68 of A28
 - Receiver R3; W67 of A28
 - Receiver R4; W66 of A28
 - Receiver D; W65 of A28
2. Disconnect the flexible cable at the suspect receiver.
3. Connect the spectrum analyzer to the suspect receiver connector.
4. Refer to **the IMPORTANT notice on page 4-23**. The measured signal on the spectrum analyzer should be at 7.61 MHz (analyzers with DSP version 4.0), or 7.44 MHz (analyzers with DSP version 5.0), and 1 GHz.
 - If the measured signal is present, continue testing at **“Checking the A24 IF Multiplexer Board” on page 4-41**.
5. If the measured signal is missing on the R1 receiver, continue testing at **“Checking the A37 Reference Mixer Switch” on page 4-40**.

If the measured signal is missing on any receiver (other than the R1 receiver noted above) and the analyzer does not have receiver attenuators, replace the A27 or A28 mixer brick, whichever is appropriate. Refer to **“Removing and Replacing the A27 and A28 Mixer Bricks” on page 7-34**.

If the measured signal is missing on the A, B, C, or D receivers and the analyzer has receiver attenuators, continue testing at **“Checking the A46, A47, A48, and A49 35-dB Receiver Step Attenuators” on page 4-41**.

Checking the A37 Reference Mixer Switch

1. Remove the front panel REF 1 jumper and connect a spectrum analyzer to the front-panel REF 1 SOURCE OUT connector.
2. If the measured signal is present, replace the A27 mixer brick. Refer to **“Removing and Replacing the A27 and A28 Mixer Bricks” on page 7-34**.

3. If the measured signal is not present, replace the A37 reference mixer switch. Refer to [“Removing and Replacing the A37 Reference Mixer Switch” on page 7-40.](#)

Checking the A46, A47, A48, and A49 35-dB Receiver Step Attenuators

1. Locate the appropriate semirigid cable at the output of the receiver step attenuator to be checked:
 - Options 219 and 419
 - Port 1; W98 of A46
 - Port 2; W104 of A49
 - Port 3; W100 of A47
 - Port 4; W102 of A48
2. Disconnect the appropriate semirigid cable from the output of the step attenuator.
3. Connect the spectrum analyzer to the open step attenuator connector. Set the spectrum analyzer to measure a signal at 800 MHz.
4. If the 800 MHz signal is not present, replace the receiver step attenuator. Refer to [“Removing and Replacing the A38–A41 Source Attenuators and the A46–A49 Receiver Attenuators” on page 7-42.](#)
5. If the 800 MHz signal is present, replace the associated mixer brick, A27 or A28. Refer to [“Removing and Replacing the A27 and A28 Mixer Bricks” on page 7-34.](#)

Checking the A24 IF Multiplexer Board

1. Locate each of the flexible RF cables at the output receivers of the IF multiplexer board:
 - 2-port models
 - Receiver A; W69
 - Receiver R1; W72
 - Receiver R2; W73
 - Receiver B; W70
 - 4-port models
 - Receiver A; W69
 - Receiver B; W70
 - Receiver C; W72
 - Receiver D; W73
 - Receiver R; W71
2. Disconnect the appropriate flexible RF cable from the output receiver to be tested on the A24 IF multiplexer board.
3. Connect the spectrum analyzer to the open connector.
4. Refer to [the IMPORTANT notice on page 4-23.](#) The measured signal on the spectrum analyzer should be at 7.61 MHz (analyzers with DSP version 4.0), or 7.44 MHz (analyzers with DSP version 5.0), and 1 GHz.
5. If the measured signal is present, replace the A16 SPAM board. Refer to [“Removing and Replacing the](#)

[A4–A17 Boards” on page 7-14.](#)

6. If the measured signal is not present, replace the A24 IF multiplexer board. Refer to [“Removing and Replacing the A24 IF Multiplexer Board” on page 7-28.](#)

Band	Mixer Brick LO Harmonic Number	1	2	3	4	5
		A15 Synthesizer Frequency (GHz)	A25 HMA26.5 Frequency (GHz)	A4/A17 Synthesizer Frequency (GHz)	ASA10 Source Frequency (GHz)	ATPARA123A13 50 GHz Doubler Frequency (GHz)
0	-	-	-	-	-	-
1	-	-	-	-	-	-
2	1	0.01083 to 0.05383	0.01083 to 0.05383	0.010 to 0.053	0.010 to 0.053	0.010 to 0.053
3	1	0.06044 to 0.18244	0.06044 to 0.18244	0.053 to 0.175	0.053 to 0.175	0.053 to 0.175
4	1	0.18244 to 0.25744	0.18244 to 0.25744	0.175 to 0.250	0.175 to 0.250	0.175 to 0.250
5	1	0.25744 to 0.50744	0.25744 to 0.50744	0.250 to 0.500	0.250 to 0.500	0.250 to 0.500
6	1	0.50744 to 1.00744	0.50744 to 1.00744	0.500 to 1.000	0.500 to 1.000	0.500 to 1.000
7	1	1.00744 to 2.00744	1.00744 to 2.00744	1.000 to 2.000	1.000 to 2.000	1.000 to 2.000
8	1	2.00744 to 3.00744	2.00744 to 3.00744	2.000 to 3.000	2.000 to 3.000	2.000 to 3.000
9	1	3.00744 to 4.00744	3.00744 to 4.00744	3.000 to 4.000	3.000 to 4.000	3.000 to 4.000
10	1	4.00744 to 5.33944	4.00744 to 5.33944	4.000 to 5.332	4.000 to 5.332	4.000 to 5.332
11	1	5.33944 to 6.75944	5.33944 to 6.75944	5.332 to 6.752	5.332 to 6.752	5.332 to 6.752
12	1	6.75944 to 8.00744	6.75944 to 8.00744	6.752 to 8.000	6.752 to 8.000	6.752 to 8.000
13	1	8.00744 to 10.67144	8.00744 to 10.67144	8.000 to 10.664	8.000 to 10.664	8.000 to 10.664
14	1	10.67144 to 13.51744	10.67144 to 13.51744	10.664 to 13.510	10.664 to 13.510	10.664 to 13.510
15	1	13.51744 to 15.40744	13.51744 to 15.40744	13.510 to 15.400	13.510 to 15.400	13.510 to 15.400
16	1	15.40744 to 16.00744	15.40744 to 16.00744	15.400 to 16.000	15.400 to 16.000	15.400 to 16.000
17	1	16.00744 to 19.00744	16.00744 to 19.00744	16.000 to 19.000	16.000 to 19.000	16.000 to 19.000
18	1	19.00744 to 20.00744	19.00744 to 20.00744	19.000 to 20.000	19.000 to 20.000	19.000 to 20.000
19	1	20.00744 to 21.32874	20.00744 to 21.32874	20.000 to 21.328	20.000 to 21.328	20.000 to 21.328
20	1	21.32874 to 24.00744	21.32874 to 24.00744	21.328 to 24.000	21.328 to 24.000	21.328 to 24.000
21	1	24.00744 to 26.50744	24.00744 to 26.50744	24.000 to 26.500	24.000 to 26.500	24.000 to 26.500
22	1	26.50744 to 27.00744	26.50744 to 27.00744	26.500 to 27.000	26.500 to 27.000	26.500 to 27.000
23	3	8.8358 to 9.0051	8.8358 to 9.0051	13.250 to 13.504	13.250 to 13.504	26.500 to 27.000
24	3	9.0051 to 10.6691	9.0051 to 10.6691	6.752 to 8.000	13.504 to 16.000	27.008 to 32.000
25	3	10.6691 to 13.5025	10.6691 to 13.5025	8.000 to 10.125	16.000 to 20.250	32.000 to 40.500
26	3	6.7512 to 7.1106	13.5025 to 14.2211	10.125 to 10.664	20.250 to 21.328	40.500 to 42.656
27	3	7.1106 to 7.2512	14.2211 to 14.5025	10.664 to 10.875	21.328 to 21.750	42.656 to 43.500
28	3	7.2512 to 7.7012	14.5025 to 15.4025	10.875 to 11.550	21.750 to 23.100	43.500 to 46.200
29	3	7.7012 to 8.0012	15.4025 to 16.0025	11.550 to 12.000	23.100 to 24.000	46.200 to 48.000
30	3	8.0012 to 8.3346	16.0025 to 16.6691	12.000 to 12.500	24.000 to 25.000	48.000 to 50.000

Test Node	Error Description	Assembly	Frequency Band
8	Unveiled, Source 1, Out 1	A5	0.01 - 13.5 GHz
9	Unveiled, Source 1, Out 2	A5	0.01 - 13.5 GHz
10	Unveiled, Source 1 Synthesizer	A4	Full Range
11	Unveiled, Source 2, Out 1	A10	0.01 - 13.5 GHz
12	Unveiled, Source 2, Out 2	A10	0.01 - 13.5 GHz
13	Unveiled, Source 2 Synthesizer	A17	Full Range
14	Unveiled, LO Drive	A25	Full Range
15	Unveiled, LO Synthesizer	A15	Full Range
16	Unveiled, Source 1 Synthesizer, Integrator Low	A4	Full Range
17	Unveiled, Source 1 Synthesizer, Integrator High	A4	Full Range
18	Unveiled, Source 2 Synthesizer, Integrator Low	A17	Full Range
20	Unveiled, Source 2 Synthesizer, Integrator High	A17	Full Range
22	Unveiled, LO Synthesizer, Integrator Low	A15	Full Range
23	Unveiled, LO Synthesizer, Integrator High	A15	Full Range
25	Unveiled, Doubler 1 Prelevel	A7	13.5 - 50 GHz
26	Unveiled, Doubler 2 Prelevel	A8	13.5 - 50 GHz
27	Unveiled, Doubler 3 Prelevel	A12	13.5 - 50 GHz
28	Unveiled, Doubler 4 Prelevel	A13	13.5 - 50 GHz
29	Unveiled, Source 1, P4	A5	13.5 - 50 GHz
30	Unveiled, Source 2, P4	A10	13.5 - 50 GHz

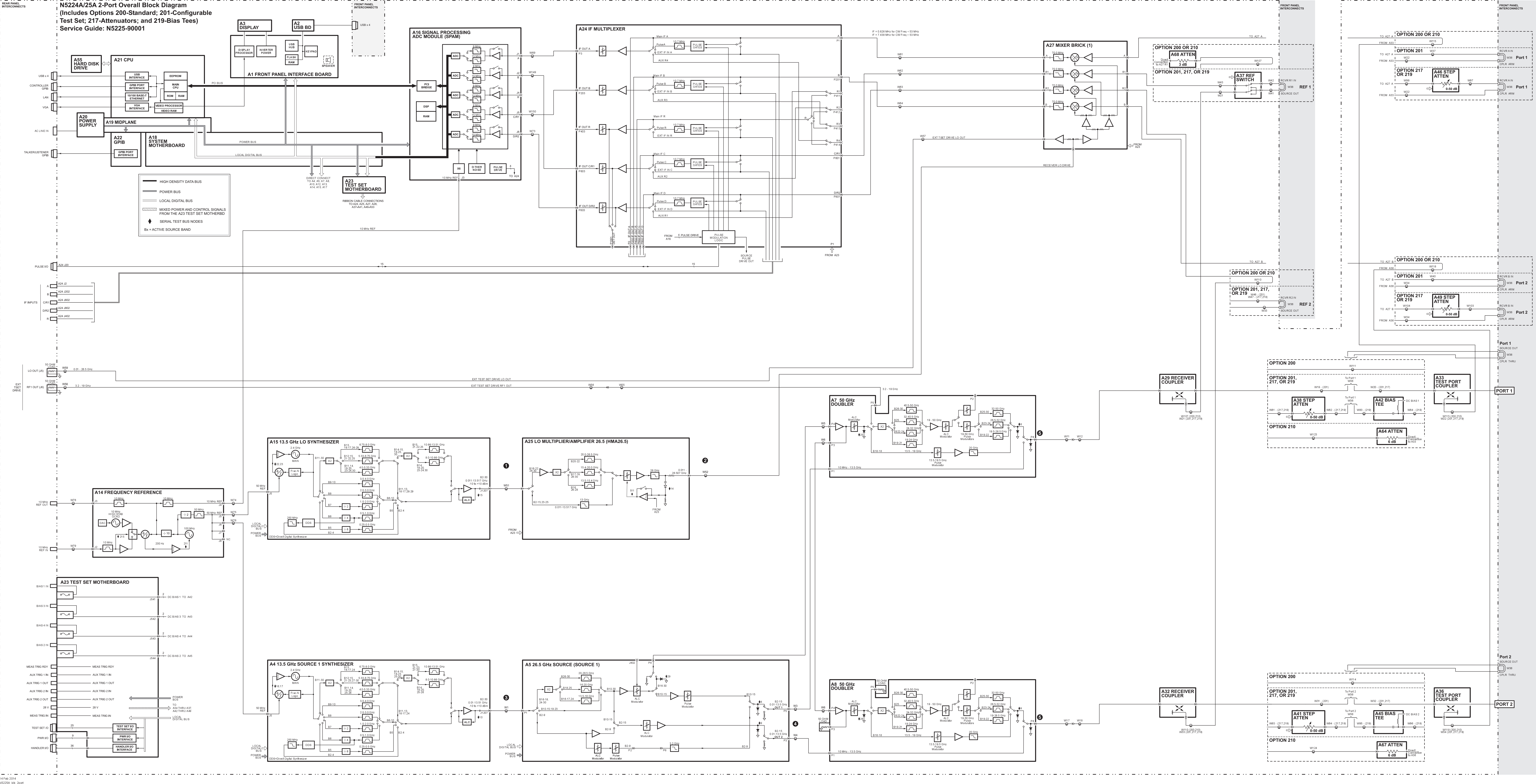

Band	Mixer Block LO Harmonic Number	1	2	3	4	5
		A15 Synthesizer Frequency (GHz)	A25 HMA26.5 Frequency (GHz)	A4A17 Synthesizer Frequency (GHz)	ASA10 Source Frequency (GHz)	ATA80A12313 50 GHz Doubler Frequency (GHz)
0	-	-	-	-	-	-
1	-	-	-	-	-	-
2	1	0.01083 to 0.05383	0.01083 to 0.05383	0.010 to 0.053	0.010 to 0.053	0.010 to 0.053
3	1	0.06044 to 0.18244	0.06044 to 0.18244	0.053 to 0.175	0.053 to 0.175	0.053 to 0.175
4	1	0.18244 to 0.25744	0.18244 to 0.25744	0.175 to 0.250	0.175 to 0.250	0.175 to 0.250
5	1	0.25744 to 0.50744	0.25744 to 0.50744	0.250 to 0.500	0.250 to 0.500	0.250 to 0.500
6	1	0.50744 to 1.0074	0.50744 to 1.0074	0.500 to 1.000	0.500 to 1.000	0.500 to 1.000
7	1	1.0074 to 2.0074	1.0074 to 2.0074	1.000 to 2.000	1.000 to 2.000	1.000 to 2.000
8	1	2.0074 to 3.0074	2.0074 to 3.0074	2.000 to 3.000	2.000 to 3.000	2.000 to 3.000
9	1	3.0074 to 3.2074	3.0074 to 3.2074	3.000 to 3.200	3.000 to 3.200	3.000 to 3.200
10	1	3.2074 to 4.0074	3.2074 to 4.0074	3.200 to 4.000	3.200 to 4.000	3.200 to 4.000
11	1	4.0074 to 5.3394	4.0074 to 5.3394	4.000 to 5.332	4.000 to 5.332	4.000 to 5.332
12	1	5.3394 to 6.7594	5.3394 to 6.7594	5.332 to 6.752	5.332 to 6.752	5.332 to 6.752
13	1	6.7594 to 8.0074	6.7594 to 8.0074	6.752 to 8.000	6.752 to 8.000	6.752 to 8.000
14	1	8.0074 to 10.6714	8.0074 to 10.6714	8.000 to 10.664	8.000 to 10.664	8.000 to 10.664
15	1	10.6714 to 13.5174	10.6714 to 13.5174	10.664 to 13.510	10.664 to 13.510	10.664 to 13.510
16	1	6.7587 to 7.7037	13.5174 to 15.4074	6.755 to 7.700	13.510 to 15.400	13.510 to 15.400
17	1	7.7037 to 8.0037	15.4074 to 16.0074	7.700 to 8.000	15.400 to 16.000	15.400 to 16.000
18	1	8.0037 to 9.5037	16.0074 to 19.0074	8.000 to 9.500	16.000 to 19.000	16.000 to 19.000
19	1	9.5037 to 10.0037	19.0074 to 20.0074	9.500 to 10.000	19.000 to 20.000	19.000 to 20.000
20	1	10.0037 to 10.6677	20.0074 to 21.3354	10.000 to 10.664	10.000 to 10.664	20.000 to 21.328
21	1	10.6677 to 12.0037	21.3354 to 24.0074	10.664 to 12.000	10.664 to 12.000	21.328 to 24.000
22	1	12.0037 to 13.2537	24.0074 to 26.5074	12.000 to 13.250	12.000 to 13.250	24.000 to 26.500
23	3	8.8358 to 9.0051	8.8358 to 9.0051	8.835 to 9.005	13.250 to 13.504	26.500 to 27.008
24	3	9.0051 to 10.6691	9.0051 to 10.6691	6.752 to 8.000	13.504 to 16.000	27.008 to 32.000
25	3	10.6691 to 13.5025	10.6691 to 13.5025	8.000 to 10.125	16.000 to 20.250	32.000 to 40.500
26	3	6.7512 to 7.1106	13.5025 to 14.2211	10.125 to 10.864	20.250 to 21.328	40.500 to 42.656
27	3	7.1106 to 7.2512	14.2211 to 14.5025	10.864 to 10.875	21.328 to 21.750	42.656 to 43.500
28	3	7.2512 to 7.7012	14.5025 to 15.4025	10.875 to 11.550	21.750 to 23.100	43.500 to 46.200
29	3	7.7012 to 8.0012	15.4025 to 16.0025	11.550 to 12.000	23.100 to 24.000	46.200 to 48.000
30	3	8.0012 to 8.3346	16.0025 to 16.6691	12.000 to 12.500	24.000 to 25.000	48.000 to 50.000

Test Node	Error Description	Assembly	Frequency Band
8	Unleveled, Source 1, Out 1	A5	0.01 - 13.5 GHz
9	Unleveled, Source 1, Out 2	A7	13.5 - 50 GHz
10	Unleveled, Source 1 Synthesizer	A4	Full Range
11	Unleveled, Source 2, Out 1	A10	0.01 - 13.5 GHz
12	Unleveled, Source 2, Out 2	A10	0.01 - 13.5 GHz
13	Unleveled, Source 2 Synthesizer	A15	Full Range
14	Unleveled, LO Drive	A25	Full Range
15	Unleveled, LO Synthesizer	A15	Full Range
16	Unleveled, Source 1 Synthesizer, Integrator Low	A4	Full Range
17	Unleveled, Source 1 Synthesizer, Integrator High	A4	Full Range
18	Unleveled, Source 2 Synthesizer, Integrator Low	A15	Full Range
20	Unleveled, Source 2 Synthesizer, Integrator High	A15	Full Range
22	Unleveled, LO Synthesizer, Integrator Low	A15	Full Range
23	Unleveled, LO Synthesizer, Integrator High	A15	Full Range
25	Unleveled, Doubler 1 Prelevel	A7	13.5 - 50 GHz
26	Unleveled, Doubler 2 Prelevel	A8	13.5 - 50 GHz
27	Unleveled, Doubler 3 Prelevel	A12	13.5 - 50 GHz
28	Unleveled, Doubler 4 Prelevel	A13	13.5 - 50 GHz
29	Unleveled, Source 1, P4	A5	13.5 - 50 GHz
30	Unleveled, Source 2, P4	A10	13.5 - 50 GHz

N5224A/25A 4-Port Overall Block Diagram
 (Includes Options 400-Standard; 401-Configurable
 Test Set; 417-Attenuators; and 419-Bias Tees)
 Service Guide: N5225-90001

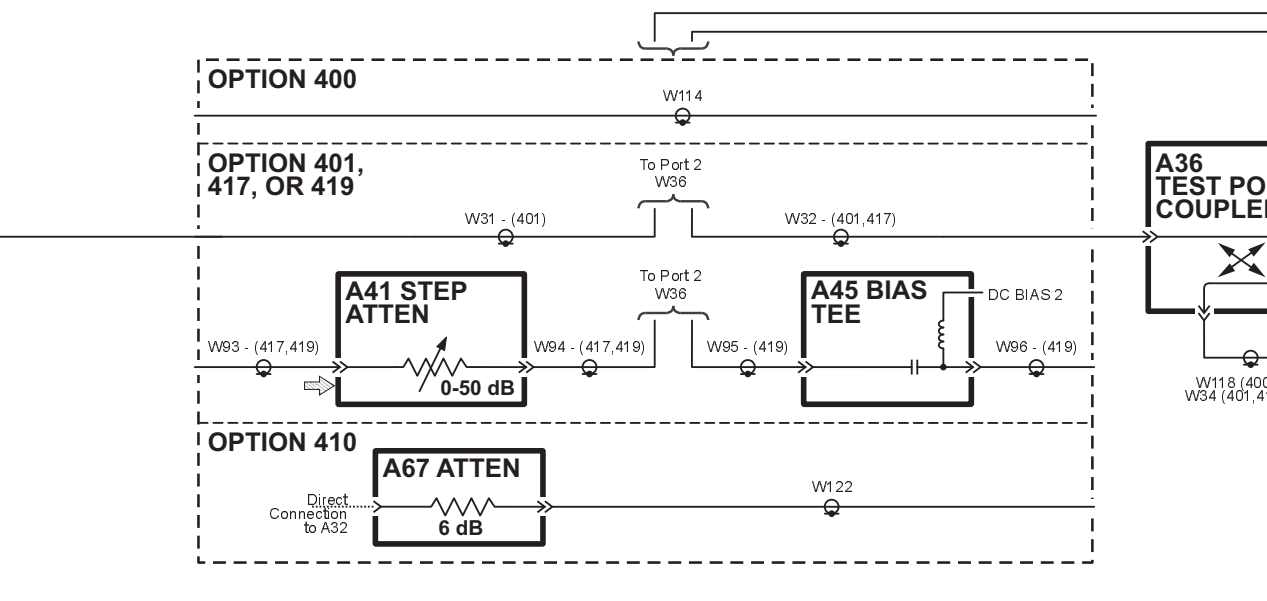
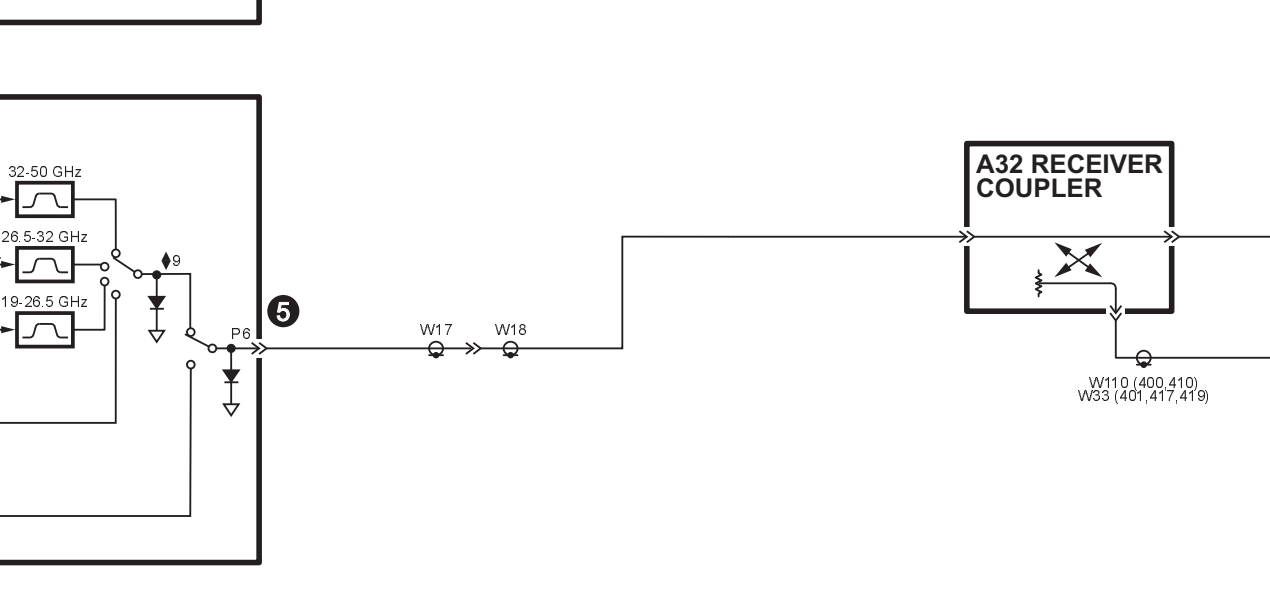
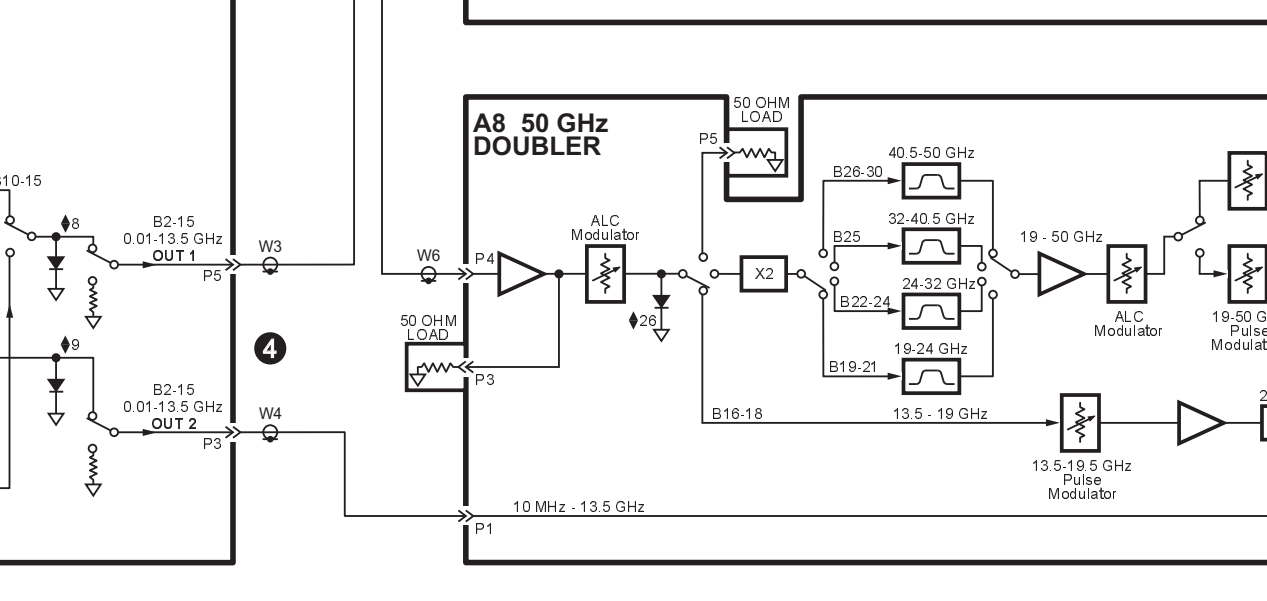
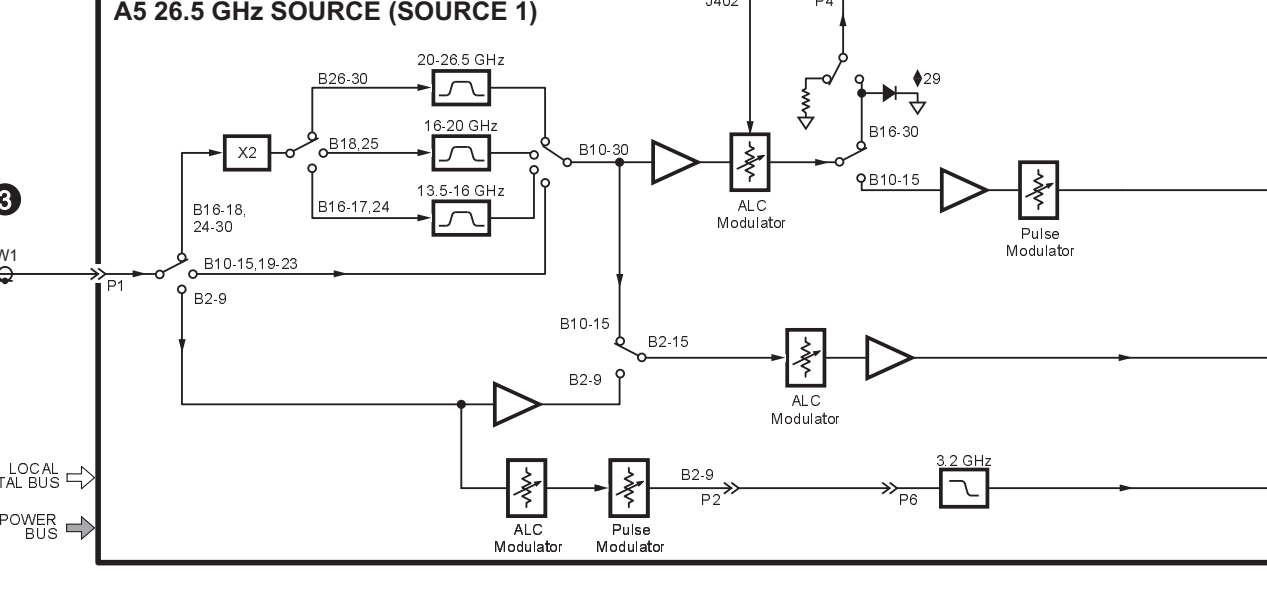
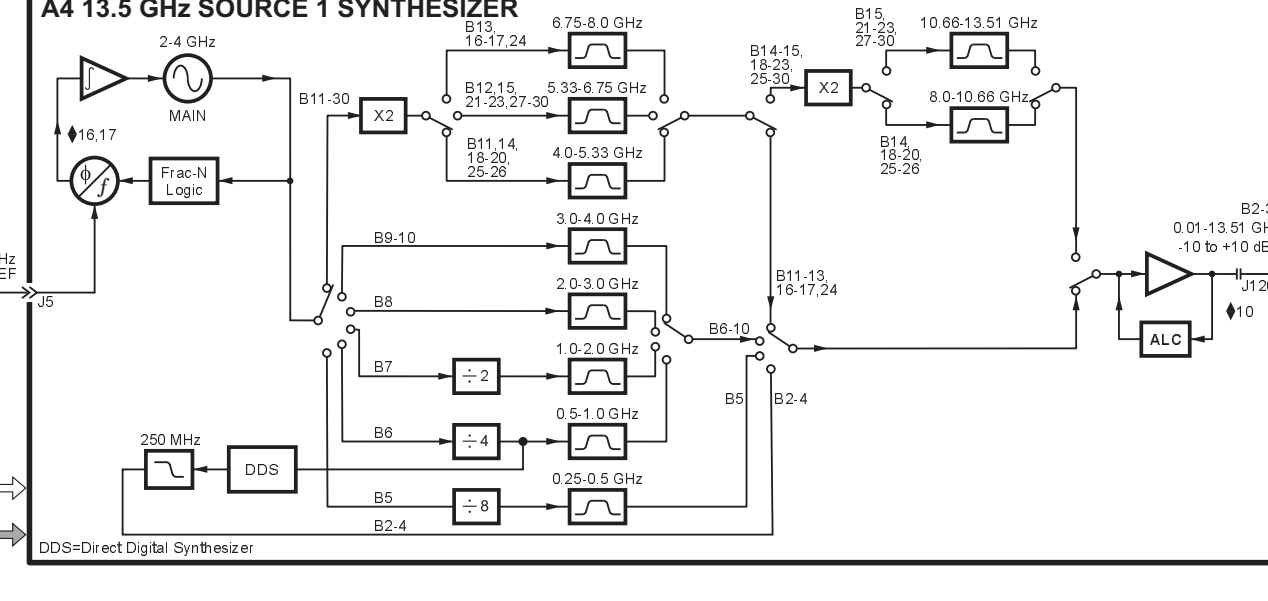
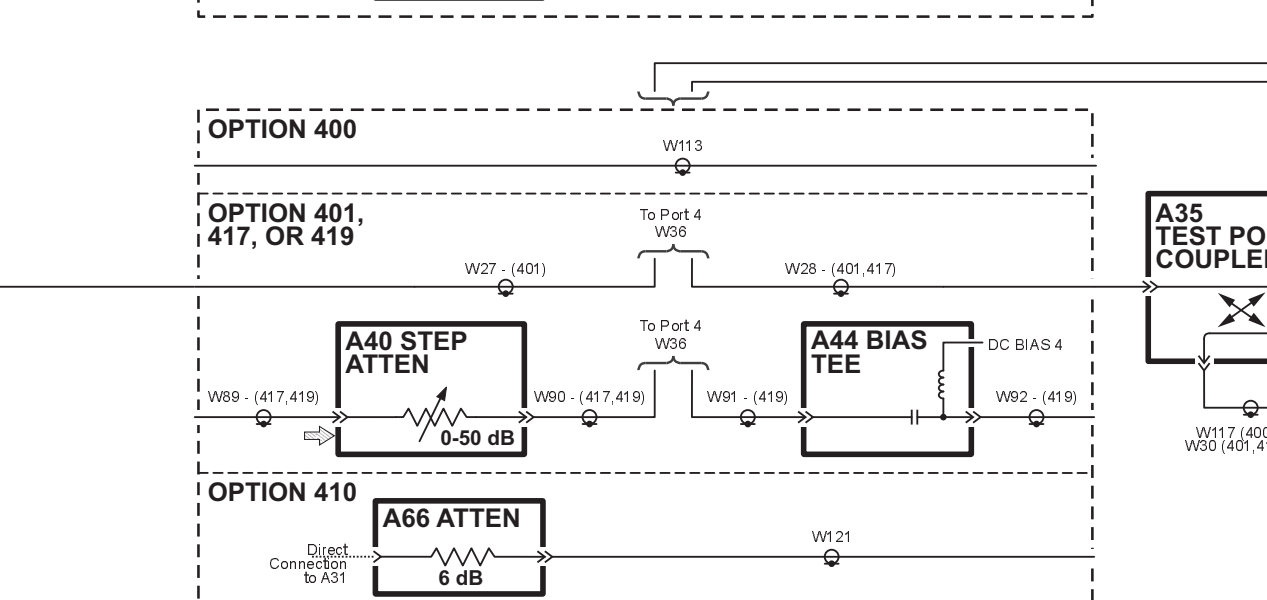
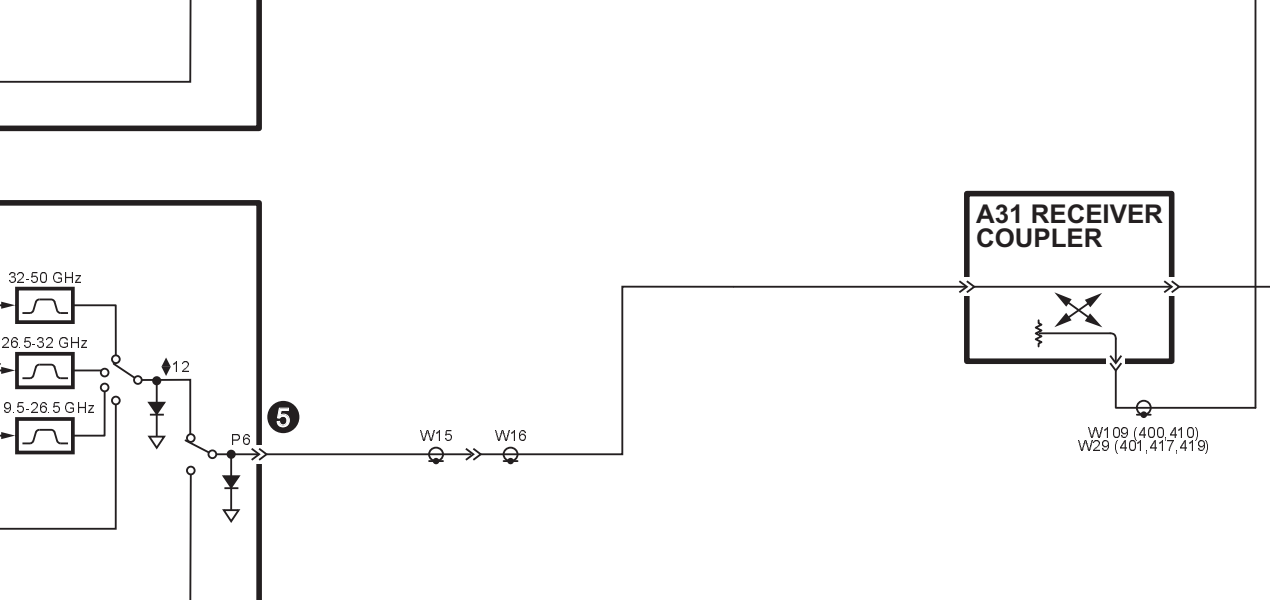
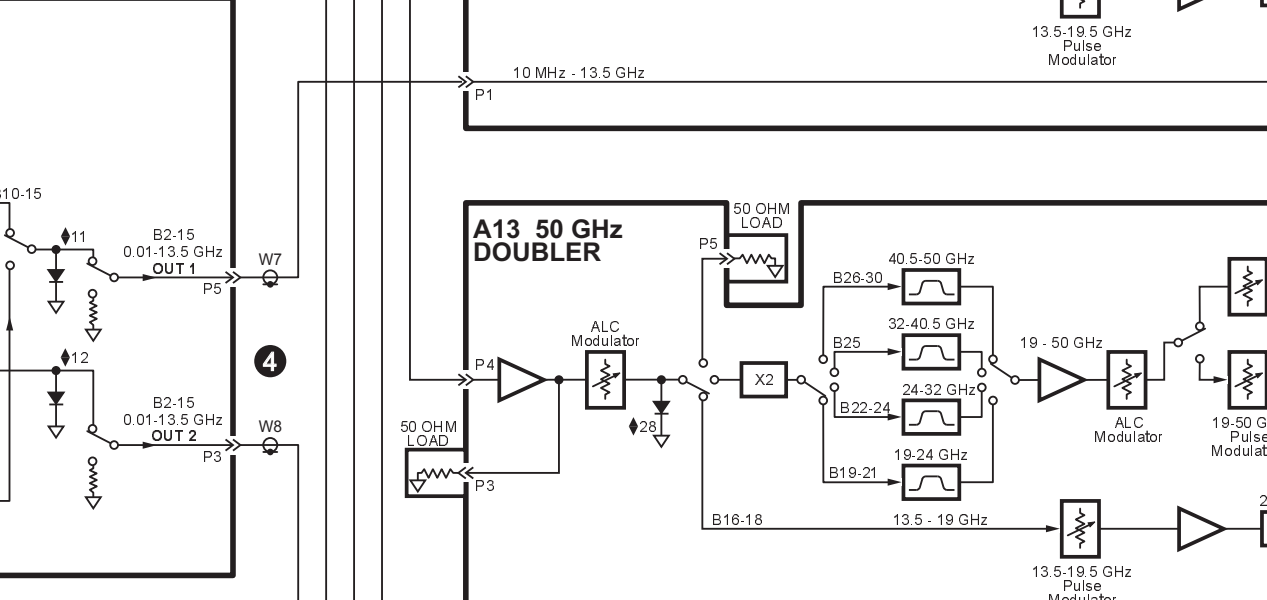
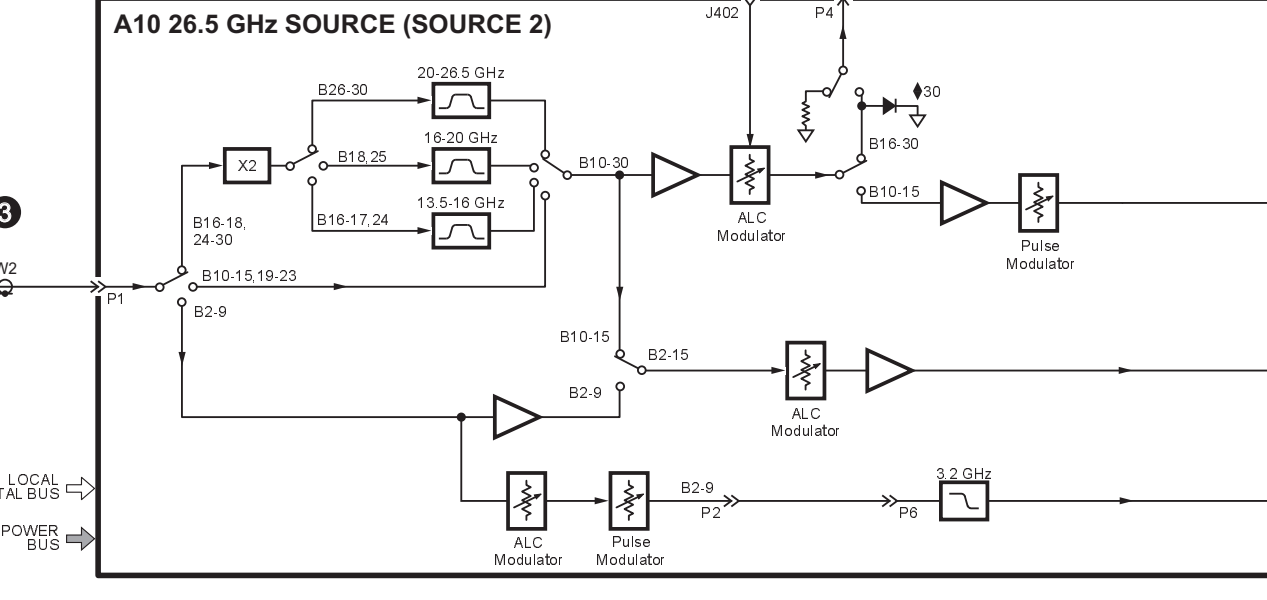
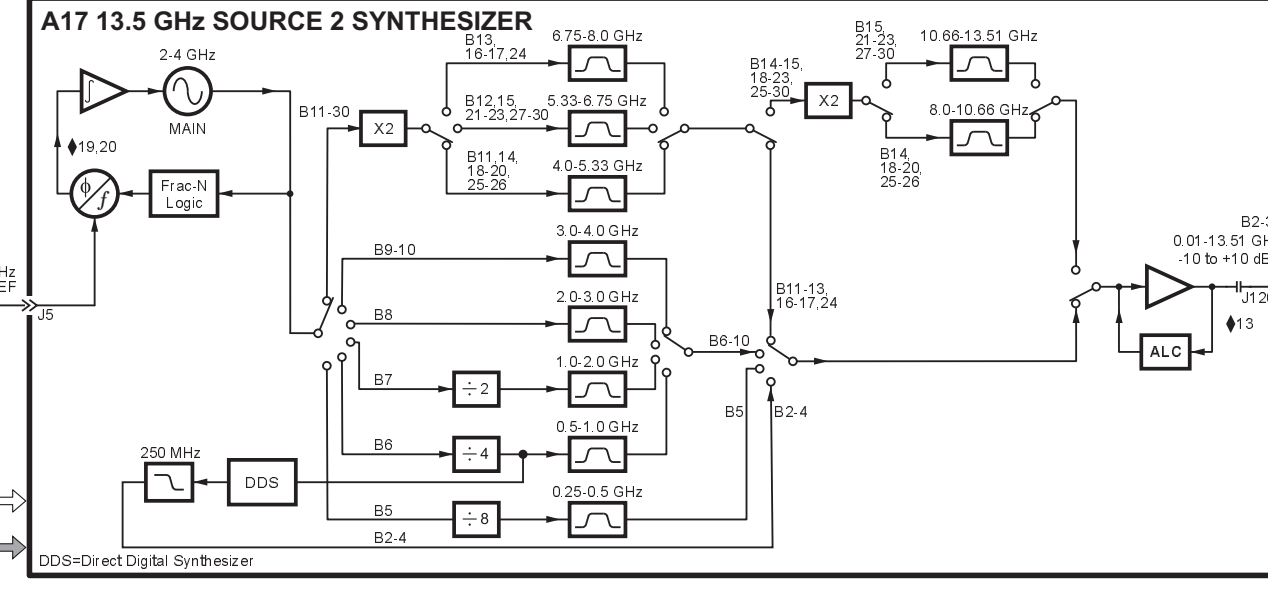
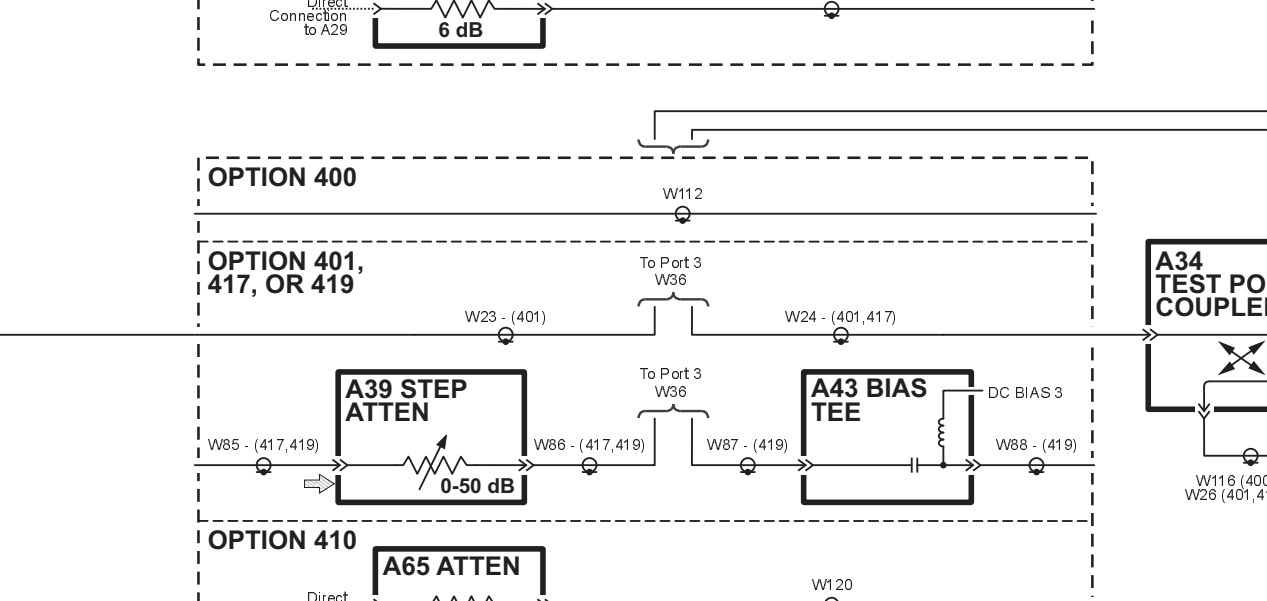
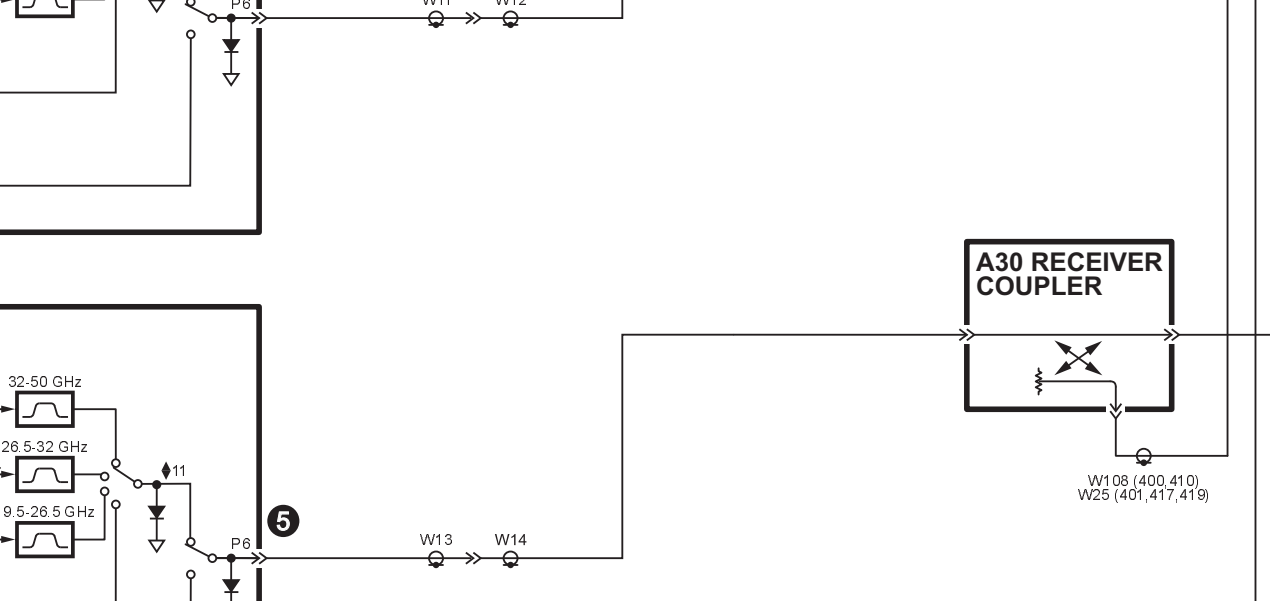
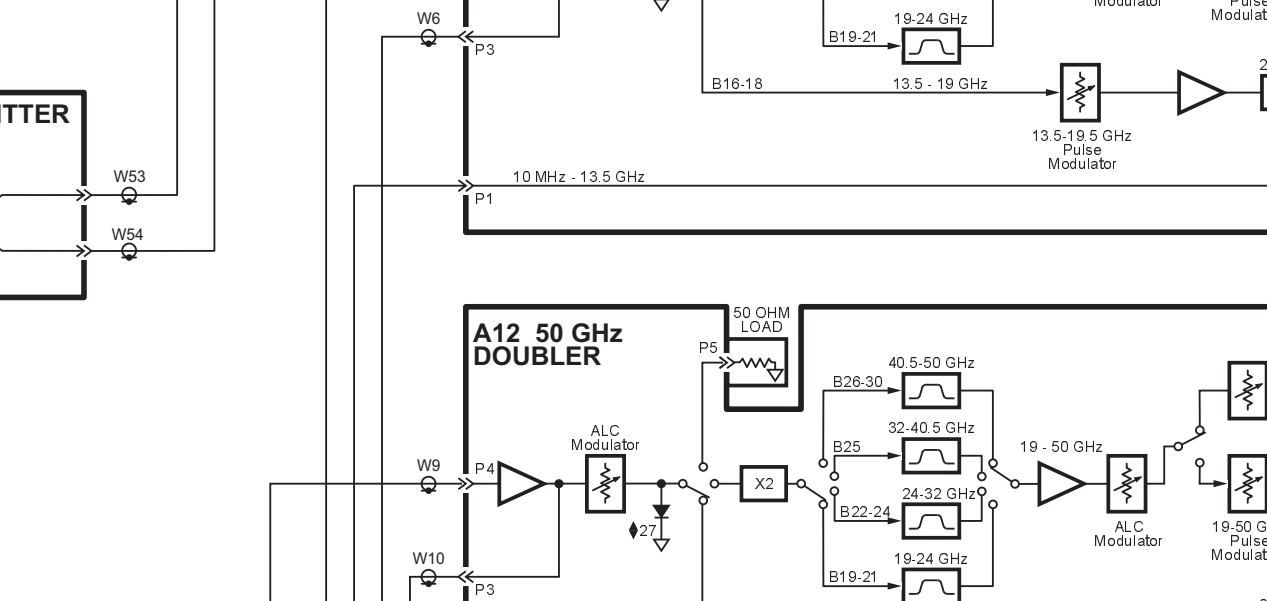
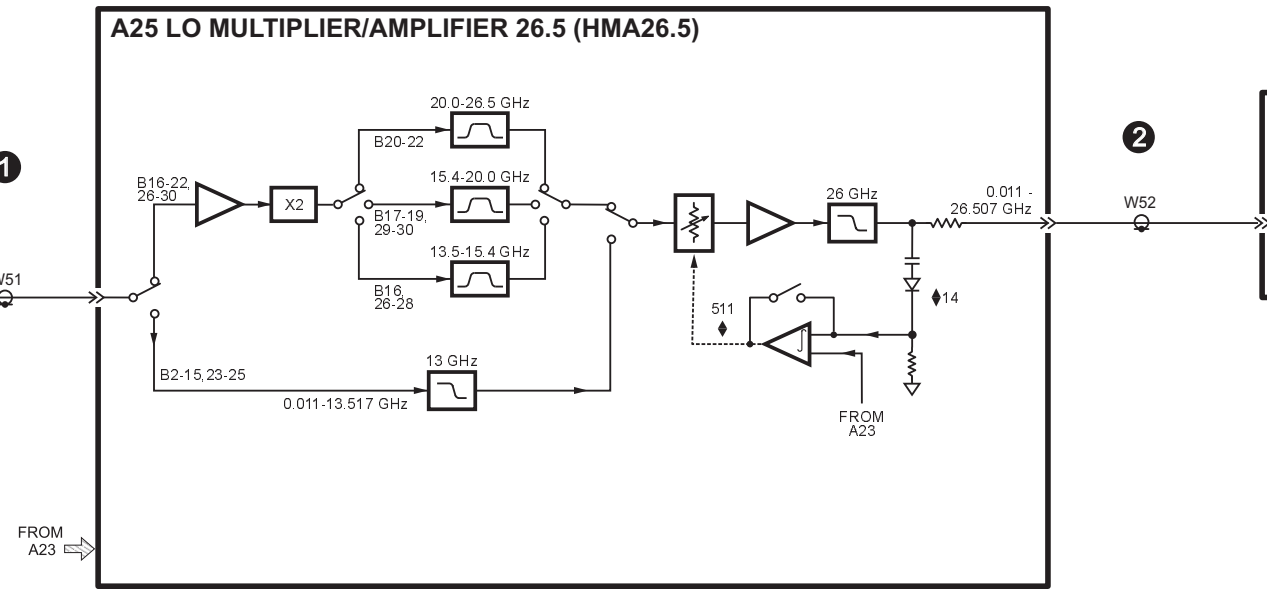
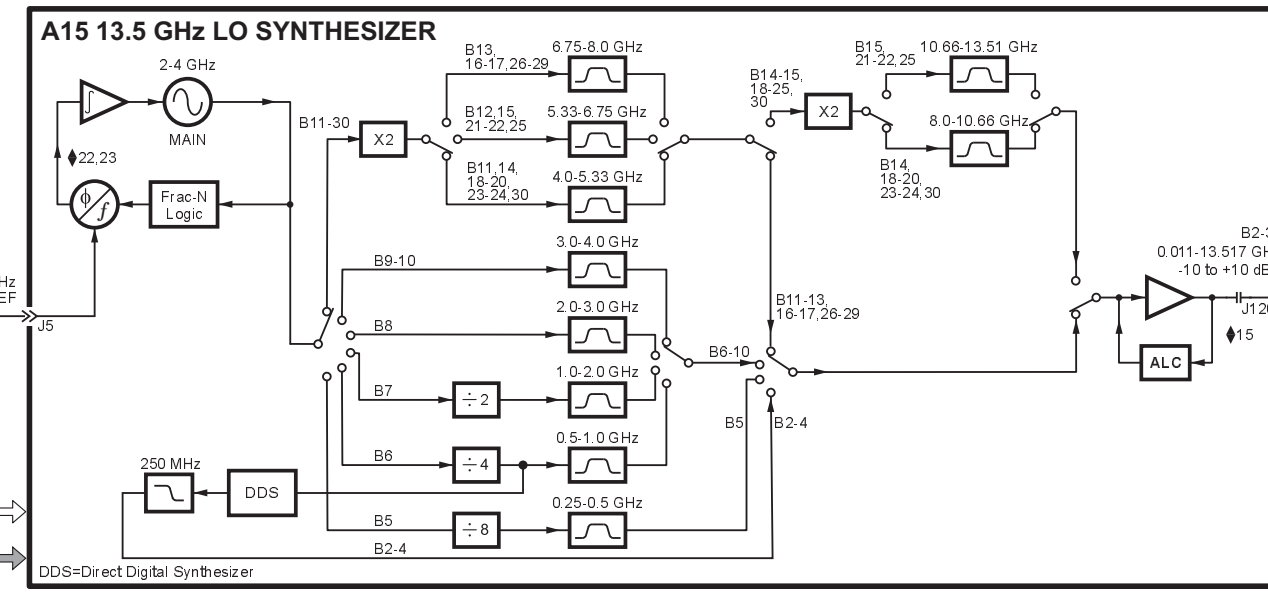
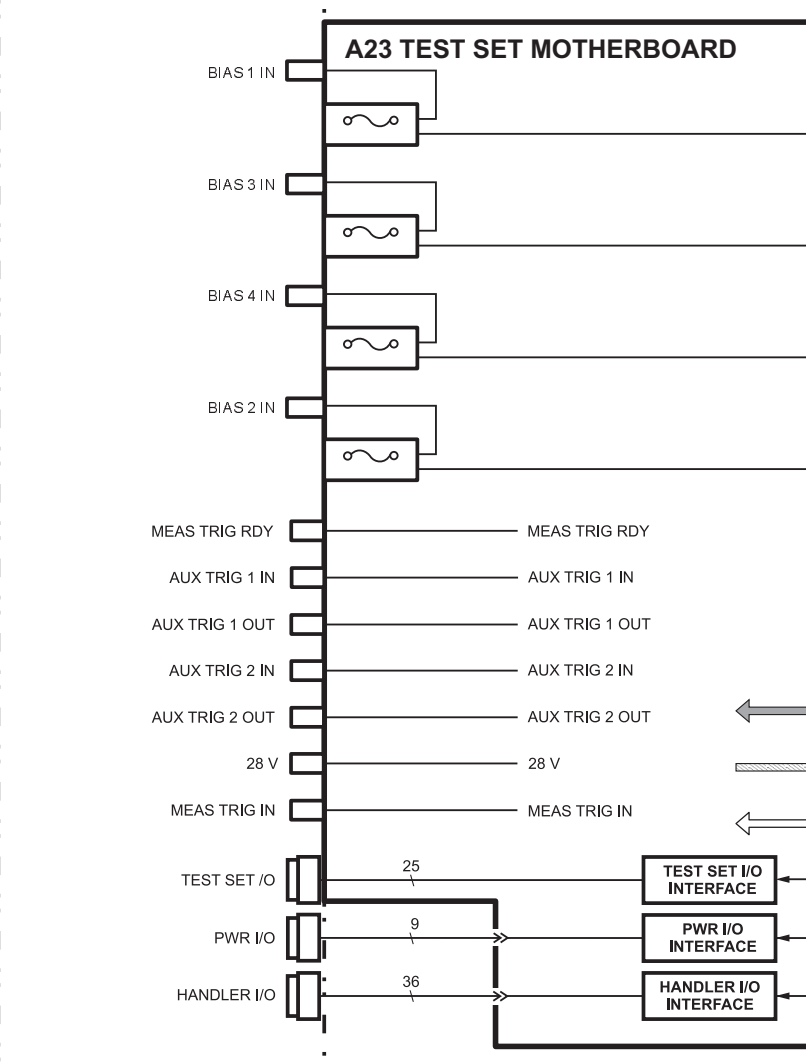
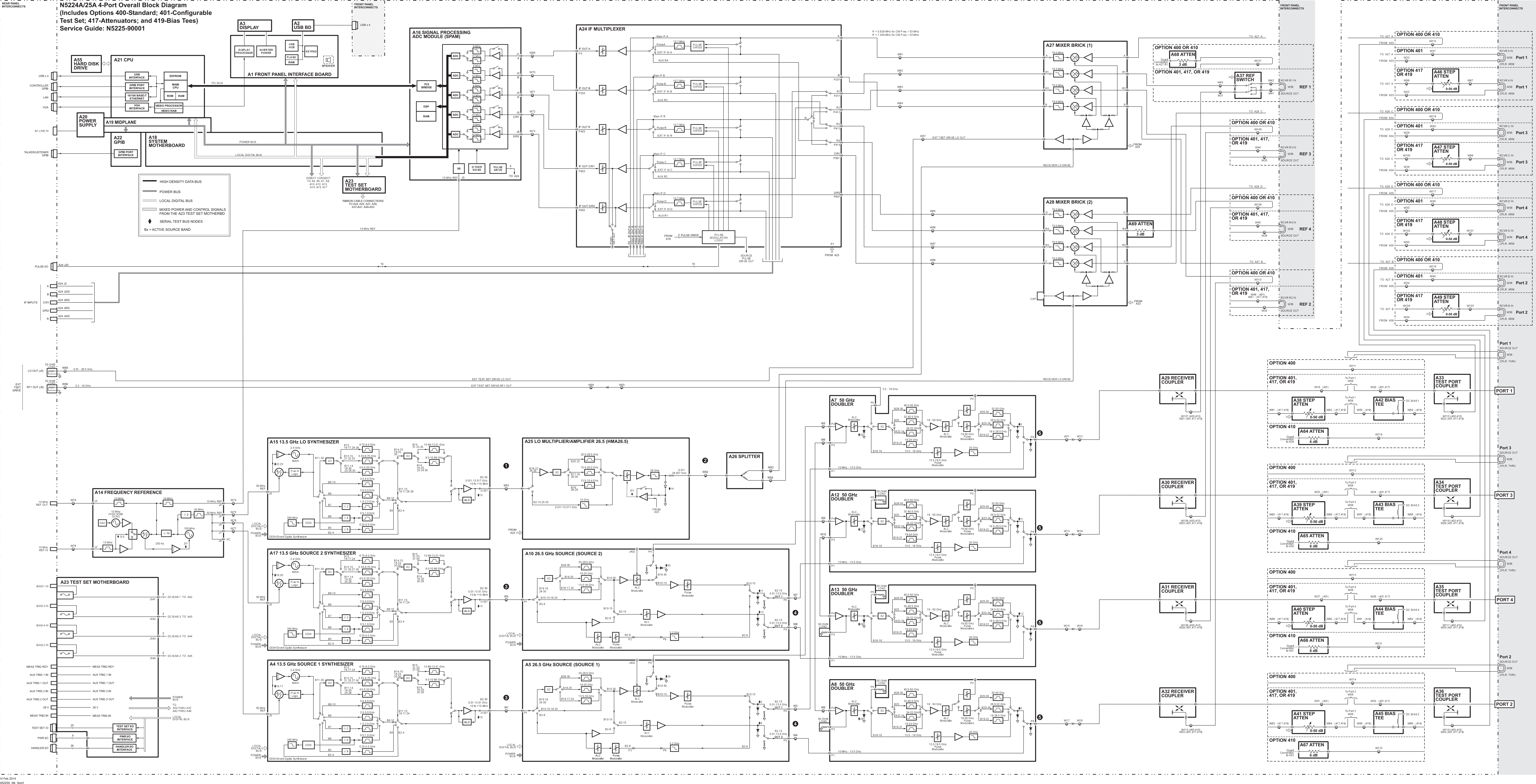

5 Theory of Operation

Information in This Chapter

This chapter provides a general description of the operating theory of the N522xA 2-port and 4-port PNA microwave network analyzers.

- Theory of operation is explained to the assembly level only.
- Component-level circuit theory is not provided.
- Simplified block diagrams are included for each functional group.
- More detailed block diagrams are located at the end of **Chapter 4, "Troubleshooting."**

IMPORTANT Although simplified block diagrams are included within the description of each functional group, it is recommended that the more detailed block diagrams, located at the end of **Chapter 4**, be available for reference, as you read the information in this chapter.

Chapter Five at-a-Glance

Section Title	Summary of Content	Start Page
Network Analyzer System Operation	A summary of the theory of operation for the analyzer. A summary of the operation of the major functional groups of the analyzer.	Page 5-3
Synthesized Source Group Operation	Operation of the assemblies associated with the source group.	Page 5-7
Signal Separation Group Operation	Operation of the assemblies associated with signal separation, including the operation of optional source attenuators, and bias tees.	Page 5-17
Receiver Group Operation	Operation of the assemblies associated with the receiver group including the operation of optional receiver attenuators.	Page 5-21
Digital Processing and Digital Control Group Operation	Operation of the assemblies associated with digital processing and digital control.	Page 5-26
Power Supply Group Operation	Operation of the power supply assembly group.	Page 5-31

Network Analyzer System Operation

The PNA network analyzer generates two (2-port models) or four (4-port models) phase-locked incident signals and an LO signal from the internal synthesized source. By means of signal separation, the incident signals are divided into reference signals and test signals.

The reference signals are applied to the receiver group, while the test signals are applied to the device under test (DUT) and then to the receiver group. The LO signal is applied directly to the receiver group where it is mixed with the test and reference signals to produce IF signals for each of the eight receivers (A–D, R1–R4) for 4-port models or four receivers (A, B, R1, R2) for 2-port models. These IF signals are downconverted and then sampled and digitally processed.

Figure 5-1 is a simplified block diagram of the 4-port network analyzer system and Figure 5-2 is a simplified block diagram of the 2-port network analyzer system.

Figure 5-1 4-Port System Simplified Block Diagram

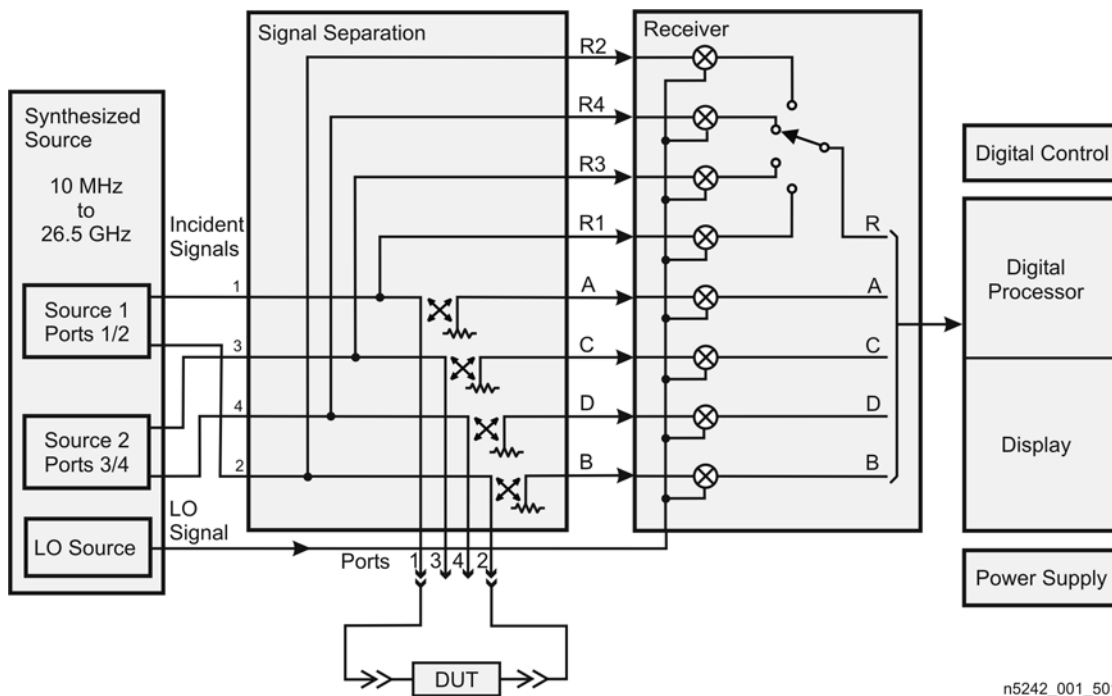

n5242_001_501

Figure 5-2 2-Port System Simplified Block Diagram

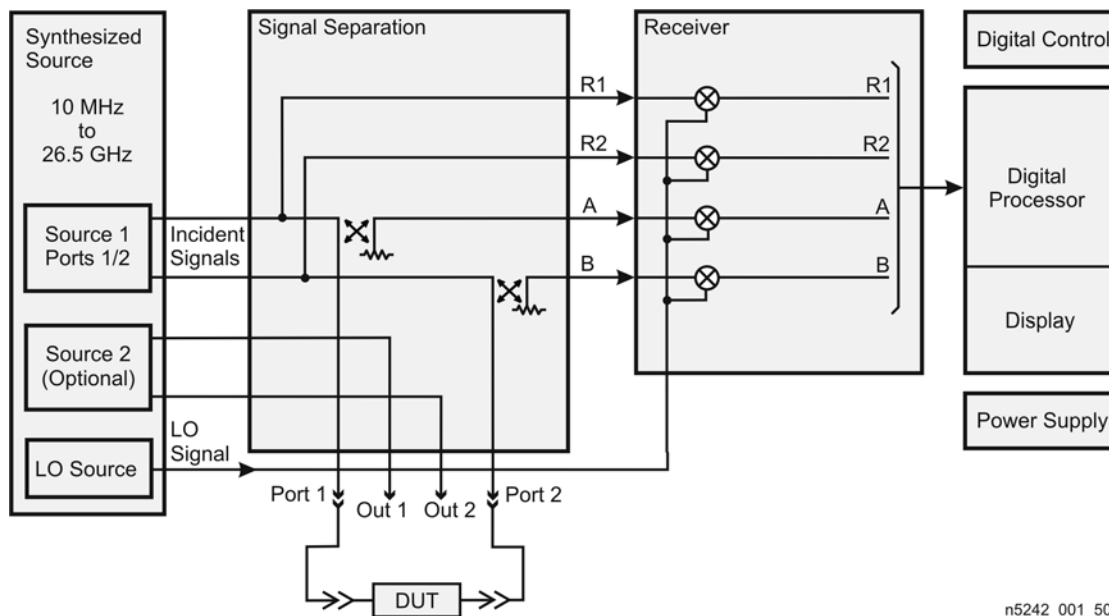

Functional Groups of the Network Analyzer

The operation of the network analyzer can be separated into major functional groups. Each group consists of assemblies that perform a distinct function in the instrument. Some of the assemblies are related to more than one group, and all of the groups, to some extent, are interrelated and affect each other's performance. The major functional groups are:

- Synthesized Source Group
- Signal Separation Group
- Receiver Group
- Digital Processor and Digital Control Group
- Power Supply Group

Synthesized Source Group

The built-in synthesized source generates a swept, stepped, or continuous wave (CW) signal in the frequency ranges as listed in the Data Sheet and Technical Specifications documents, available online at: <http://literature.cdn.keysight.com/litweb/pdf/N5224-90001.pdf> and <http://literature.cdn.keysight.com/litweb/pdf/N5224-90002.pdf>¹. The source group provides five signals: an LO signal and four incident signals. The LO signal and the four incident signals are offset in frequency by the receiver IF of 7.438 MHz (at tuned frequencies below 53 MHz the IF and the offset is 0.826 MHz).

The LO signal is sent directly to the mixers in the receiver group. The incident signals are routed to the front panel test ports and then to the device under test (DUT) as the test signal. A portion of each incident signal is coupled off (in the signal separation group) and sent to the mixers in the receiver group as reference signals. These reference signals are compared (mixed) with the LO signal in the receiver group to produce the 7.438 MHz (or 0.826 MHz at frequencies below 53 MHz) IF signal.

The incident signal output power is leveled by an internal automatic leveling control (ALC) circuit. The maximum output power level of the network analyzer at the test ports is shown in the Data Sheet and Technical Specifications documents (see hyperlinks above).¹

Refer to [“Synthesized Source Group Operation”](#) on page 5-7.

1. For frequency ranges and maximum output power levels, refer to the section “Test Port Output” in the Data Sheet and Technical Specifications documents (see hyperlinks above).

Signal Separation Group

Each of the incident signals from the source group is separated into a reference path and a test path. The reference signal is transmitted to the receiver group. The test signal is transmitted through—and reflected from—the DUT and is then transmitted to the receiver group.

The signal separation group includes:

- RF path switching to allow forward and reverse measurements
- external connections for the DUT (configurable test set)
- optional step attenuators in the source and receiver paths
- optional bias tees

Refer to [“Signal Separation Group Operation” on page 5-17.](#)

Receiver Group

The receiver converts the test and reference signals to 7.438 MHz intermediate frequency (IF) signals for signal processing, retaining both magnitude and phase characteristics. The IF signals are converted to digital information by the digital processing group.

Refer to [“Receiver Group Operation” on page 5-21.](#)

Digital Processor and Digital Control Group

The digital processor and digital control group are divided into a front panel group and a data acquisition and processing group. The front panel group provides communication to the network analyzer. The data acquisition and processing group provides the output to the display, in addition to signal processing and analyzer control.

Refer to [“Digital Processing and Digital Control Group Operation” on page 5-26.](#)

Power Supply Group

The power supply functional group provides power for the other assemblies in the instrument.

Refer to [“Power Supply Group Operation” on page 5-31.](#)

Synthesized Source Group Operation

The source group produces a stable output signal by phase locking a synthesized voltage-controlled oscillator (VCO). For the full frequency range of the source, refer to the Data Sheet and Technical Specifications documents, available online at:

<http://literature.cdn.keysight.com/litweb/pdf/N5224-90001.pdf> and

<http://literature.cdn.keysight.com/litweb/pdf/N5224-90002.pdf>¹ The outputs at the front panel test ports are swept, stepped or CW signals. Maximum leveled output powers are also listed in the Data Sheet and Technical Specifications documents.¹ For a simple block diagram of the source group, refer to [Figure 5-3 on page 5-9](#).

In this section the following are described:

- [Basic Operation](#)
- [A4, A15, and A17 13.5 GHz Synthesizer Boards](#)
- [A5 and A10 26.5 GHz Source Boards](#)
- [A7, A8, A12, and A13 50 GHz Doubler Boards](#)
- [A25 Multiplier/Amplifier 26.5 Board \(HMA26.5\)](#)
- [A14 Frequency Reference Board](#) (including rear-panel interconnects)
- [A23 Test Set Motherboard](#) (including rear-panel interconnects)

Basic Operation

[Table 5-1 on page 5-10](#) lists the L.O. harmonic number, the synthesizer frequencies (A4, A15, and A17), the main source frequency (A5 and A10), and the doubler frequencies (A7, A8, A12, and A13) within the analyzer for each band. This table is referred to throughout this chapter and also appears on the overall block diagram at the end of [Chapter 4, "Troubleshooting."](#)

The A14 frequency reference board produces a constant phase locked reference signal of 50 MHz that is sent to the A4, A15, and A17 13.5 GHz synthesizer boards.

The A15 13.5 GHz synthesizer board produces an LO signal that is sent through the A25 LO multiplier/amplifier 26.5 board to the A27 and A28 mixer bricks (via the A26 splitter). The frequency is synthesized such that the mixing product of this LO signal with the test signal output is a constant 7.438 MHz IF; except for frequencies below 53 MHz when the IF is 0.826 MHz. This IF signal is sent to the A16 SPAM board for digital processing.

The A4 13.5 GHz synthesizer board produces an incident signal that is sent through the A5 26.5 GHz source board and then through the A7 and A8 doubler boards to the front panel outputs. Likewise, the A17 13.5 GHz synthesizer board produces an incident signal that is sent through the A10 26.5 GHz source board and then through the A12 and A13 doubler boards to the front panel outputs. Portions of these signals are coupled off and sent to the A27 and A28 mixer bricks (A–D and R1–R4) where they are mixed with the LO signal from the A26 splitter to produce the 7.438 MHz (or 0.826 MHz) IF signal.

1. For frequency ranges and maximum output power levels, refer to the section "Test Port Output" in the Data Sheet and Technical Specifications documents (see hyperlinks above).

Synthesized Source Group Operation**N5224A and N5225A**

The A4, A15, and A17 13.5 GHz synthesizer boards each contain their own phase lock circuitry. The A15 board produces an independently phase locked LO signal while the A4 and A17 boards produce independently phase locked test signals. This makes it possible for the LO signal to be tuned to a different frequency than the test signal. With frequency offset mode disabled, the LO signal is 7.438 MHz higher than the test signal. Since the A4, A15, and A17 13.5 GHz synthesizer boards each receive their 50 MHz input reference signal from the exact same source, frequency drift error is eliminated.

Figure 5-3 Source Group

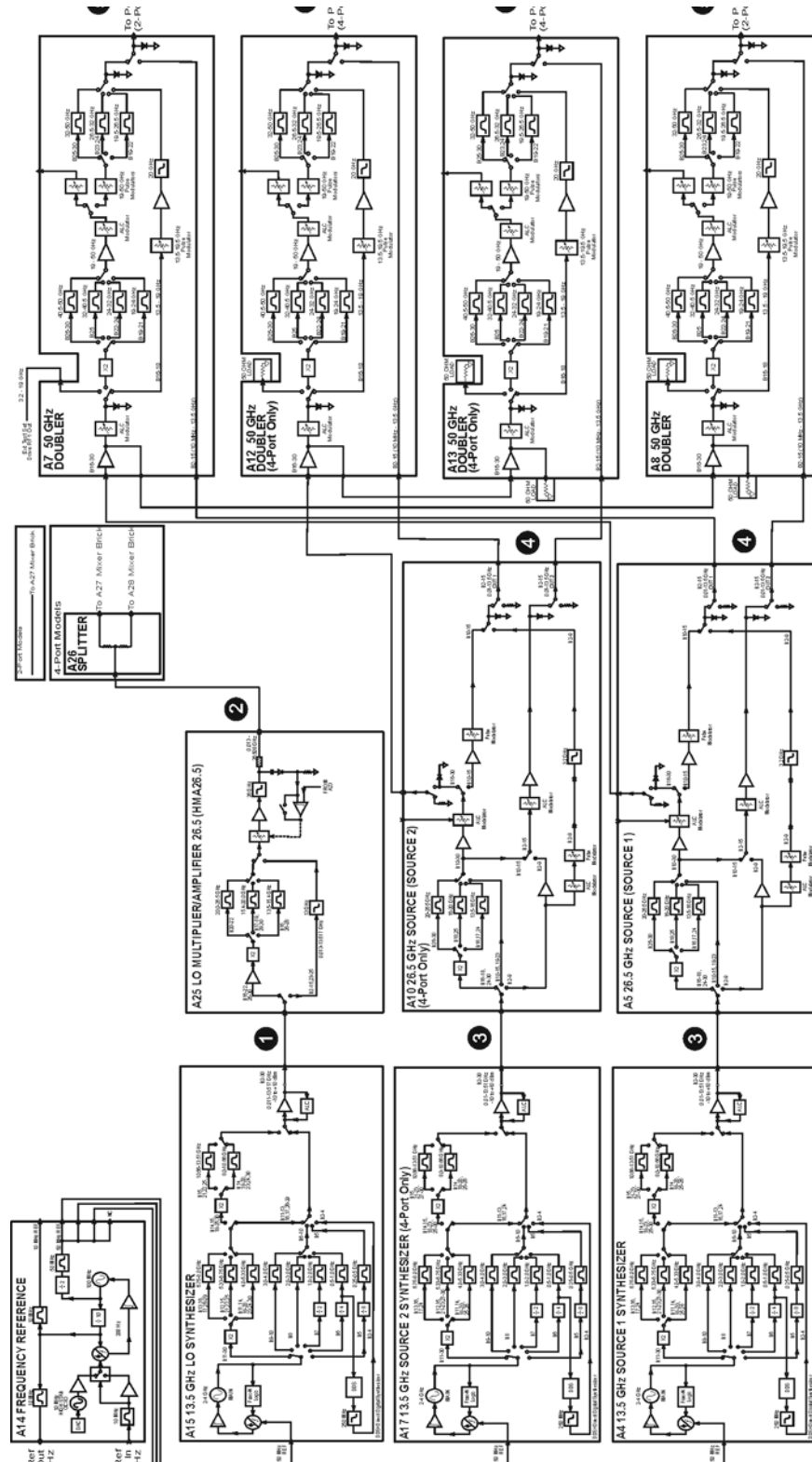

Table 5-1 Subsweep Frequencies

Band	Mixer Brick L.O. Harm. Nbr. (N)	①	②	③	④	⑤
		A15 Synthesizer Frequency (GHz)	A25 HMA26.5 Frequency (GHz)	A4/A17 Synthesizer Frequency (GHz)	A5/A10 Source Frequency (GHz)	A7/A8/A12/A13 50GHz Doubler Frequency (GHz)
0	-	-	-	-	-	-
1	-	-	-	-	-	-
2	1	0.01083 to 0.05383	0.01083 to 0.05383	0.010 to 0.053	0.010 to 0.053	0.010 to 0.053
3	1	0.06044 to 0.18244	0.06044 to 0.18244	0.053 to 0.175	0.053 to 0.175	0.053 to 0.175
4	1	0.18244 to 0.25744	0.18244 to 0.25744	0.175 to 0.250	0.175 to 0.250	0.175 to 0.250
5	1	0.25744 to 0.50744	0.25744 to 0.50744	0.250 to 0.500	0.250 to 0.500	0.250 to 0.500
6	1	0.50744 to 1.0074	0.50744 to 1.0074	0.500 to 1.000	0.500 to 1.000	0.500 to 1.000
7	1	1.0074 to 2.0074	1.0074 to 2.0074	1.000 to 2.000	1.000 to 2.000	1.000 to 2.000
8	1	2.0074 to 3.0074	2.0074 to 3.0074	2.000 to 3.000	2.000 to 3.000	2.000 to 3.000
9	1	3.0074 to 3.2074	3.0074 to 3.2074	3.000 to 3.200	3.000 to 3.200	3.000 to 3.200
10	1	3.2074 to 4.0074	3.2074 to 4.0074	3.200 to 4.000	3.200 to 4.000	3.200 to 4.000
11	1	4.0074 to 5.3394	4.0074 to 5.3394	4.000 to 5.332	4.000 to 5.332	4.000 to 5.332
12	1	5.3394 to 6.7594	5.3394 to 6.7594	5.332 to 6.752	5.332 to 6.752	5.332 to 6.752
13	1	6.7594 to 8.0074	6.7594 to 8.0074	6.752 to 8.000	6.752 to 8.000	6.752 to 8.000
14	1	8.0074 to 10.6714	8.0074 to 10.6714	8.000 to 10.664	8.000 to 10.664	8.000 to 10.664
15	1	10.6714 to 13.5174	10.6714 to 13.5174	10.664 to 13.510	10.664 to 13.510	10.664 to 13.510
16	1	6.7587 to 7.7037	13.5174 to 15.4074	6.755 to 7.700	13.510 to 15.400	13.510 to 15.400
17	1	7.7037 to 8.0037	15.4074 to 16.0074	7.700 to 8.000	15.400 to 16.000	15.400 to 16.000
18	1	8.0037 to 9.5037	16.0074 to 19.0074	8.000 to 9.500	16.000 to 19.000	16.000 to 19.000
19	1	9.5037 to 10.0037	19.0074 to 20.0074	9.500 to 10.000	9.500 to 10.000	19.000 to 20.000
20	1	10.0037 to 10.6677	20.0074 to 21.3354	10.000 to 10.664	10.000 to 10.664	20.000 to 21.328
21	1	10.6677 to 12.0037	21.3354 to 24.0074	4.000 to 5.332	4.000 to 5.332	21.328 to 24.000
22	1	12.0037 to 13.2537	24.0074 to 26.5074	12.000 to 13.250	12.000 to 13.250	24.000 to 26.500
23	3	8.8358 to 9.0051	8.8358 to 9.0051	13.250 to 13.504	13.250 to 13.504	26.500 to 27.008
24	3	9.0051 to 10.6691	9.0051 to 10.6691	6.752 to 8.000	13.504 to 16.000	27.008 to 32.000
25	3	10.6691 to 13.5025	10.6691 to 13.5025	8.000 to 10.125	16.000 to 20.250	32.000 to 40.500
26	3	6.7512 to 7.1106	13.5025 to 14.2211	10.125 to 10.664	20.250 to 21.328	40.500 to 42.656
27	3	7.1106 to 7.2512	14.2211 to 14.5025	10.664 to 10.875	21.328 to 21.750	42.656 to 43.500
28	3	7.2512 to 7.7012	14.5025 to 15.4025	10.875 to 11.550	21.750 to 23.100	43.500 to 46.200
29	3	7.7012 to 8.0012	15.4025 to 16.0025	11.550 to 12.000	23.100 to 24.000	46.200 to 48.000
30	3	8.0012 to 8.3346	16.0025 to 16.6691	12.000 to 12.500	24.000 to 25.000	48.000 to 50.000

A4, A15, and A17 13.5 GHz Synthesizer Boards

The A17 13.5 GHz synthesizer board is included only on 4-port models.

The A4, A15, and A17 13.5 GHz synthesizer boards use the 50 MHz reference signal from the A14 frequency reference board to tune a VCO circuit that sweeps from 2 GHz to 4 GHz.

Refer to [Table 5-1](#) and [Figure 5-3](#) for band numbers and frequencies discussed here.

In bands 2-10, the output of the swept VCO is passed directly or through a divide-by-2, 4, or 8 circuit to produce the output frequencies as listed in [Table 5-1](#).

In band 6, the output of the swept VCO is passed through a divide-by-4 circuit and then sent to a Direct Digital Synthesizer to produce the output frequencies for bands 2-4 as listed in [Table 5-1](#).

In bands 11-30, the swept VCO signal is passed through a doubler circuit where the signal for some bands are sent directly to the output of the synthesizer board while other bands are passed through another doubler circuit then to the output of the synthesizer board to produce the output frequencies listed in [Table 5-1](#).

The output of the A15 13.5 GHz synthesizer board (the LO synthesizer) is 7.438 MHz higher than the output of the A4 and A17 13.5 GHz synthesizer boards (the source synthesizers). This is because the output of the A15 13.5 GHz synthesizer board is routed through the A25 LO multiplier/amplifier 26.5 board to the A27 and A28 mixer bricks where they are mixed with the test signals to produce a 7.438 MHz IF signal for each of eight receivers (A-D and R1-R4). Refer to [“A27 and A28 Mixer Bricks” on page 5-21](#) for a more complete description.

A5 and A10 26.5 GHz Source Boards

The A10 26.5 GHz source board is included only on 4-port models.

Refer to [Table 5-1](#) and [Figure 5-3](#) for band numbers and frequencies discussed here.

In bands 2-9, the A5 and A10 26.5 GHz source boards input signals from the A4 or A17 13.5 GHz synthesizer board are passed through to both outputs (main and secondary) unchanged.

For bands 10-15 and 19-23, the input signals are passed directly to the secondary output or amplified and filtered, then sent to the main output.

For bands 16-18 and 24-30, the input signals are doubled, filtered, and amplified. The signals for these bands are then either passed directly to the secondary output or passed through more amplification and filtering and sent to the main output.

A7, A8, A12, and A13 50 GHz Doubler Boards

The A12 and A13 50 GHz doubler boards are included only on 4-port models.

Refer to [Table 5-1](#) and [Figure 5-3](#) for band numbers and frequencies discussed here.

For bands 2–15, the lowband input ports of the A7, A8, A12, and A13 50 GHz doubler boards receive their signals from the A5 and A10 source module OUT 1 and OUT 2 outputs. These signals are passed through to the doubler board output unchanged.

For bands 16–30, the highband input ports of the A7 and A12 50 GHz doubler boards receive their signals from the A5 and A10 source module P4 outputs. These signals are amplified by the A7 and A12 doubler boards and output via the highband output ports to the highband input ports on the A8 and A13 doubler boards.

For bands 16–18, the input signals of all four doubler boards are amplified and filtered, then sent to the doubler board output.

For bands 19–30, the input signals of all four doubler boards are doubled, amplified and filtered, then sent to the doubler board output.

Doubler board output signals for bands 2–30 create the full synthesized source output frequency range of 10 MHz to 50 GHz.

The A7 50 GHz doubler board provides an EXT TSET DRIVE RF1 OUT signal to the rear panel. This signal is output at a frequency range of 3.2–19 GHz for use with an external test set. This output is terminated with a 50-ohm load on the A8, A12, and A13 doubler boards.

The companion signal, EXT TEST SET DRIVE LO, is output from the A27 mixer brick. Refer to [“A27 and A28 Mixer Bricks”](#) on page 5-21.

A25 Multiplier/Amplifier 26.5 Board (HMA26.5)

Refer to [Table 5-1](#) and [Figure 5-3](#) for band numbers and frequencies discussed here.

In bands 2–15 and 23-25, the synthesized LO input is filtered, amplified, and passed through to the A26 splitter (4-port only). In bands 16–22 and 26-30, the input is amplified, doubled, and filtered, then sent to the output.

Together, these signal paths create the full output frequency range of 10 MHz to 26.5 GHz that is sent to the A26 splitter (4-port only) where the signal is divided and sent to the A27 and A28 (4-port only) mixer bricks as the LO signal.

A14 Frequency Reference Board

This assembly provides stable reference frequencies to the rest of the instrument. A high stability 10 MHz oven-controlled crystal oscillator (OCXO) normally provides the frequency standard. However, if a 10 MHz external reference signal is detected at the 10 MHz EXT REF IN port on the rear panel, it is used as the frequency reference instead.

The 10 MHz reference signal is used to phase lock a 100 MHz VCO. The output of this VCO is then divided by ten to produce the 10 MHz EXT REF OUT rear panel signal and also a 10 MHz reference signal for the A16 signal processing ADC module (SPAM) board. The VCO output is also divided by two to produce 50 MHz reference signals for the A4, A15, and A17 13.5 GHz synthesizer boards.

Rear-Panel Interconnects

10 MHz REF INPUT	<p>A BNC connector that allows an external frequency reference signal to be used to phase lock the analyzer for increased frequency accuracy.</p> <p>The analyzer automatically enables the external frequency reference feature when a signal is connected to this input. When the signal is removed, the analyzer automatically switches back to its internal frequency reference.</p>
10 MHz REF OUTPUT	<p>A BNC connector that allows a 10 MHz reference signal, produced by the A14 frequency reference board, to be output for use in phase locking external test equipment.</p>

A23 Test Set Motherboard

The A23 test set motherboard serves these functions:

- to act as an interface between the A21 CPU board and the auxiliary rear panel interconnects.
- to provide ALC signals to the A25 HMA26.5.
- to route control signals to the signal separation group. Refer to **“Signal Separation Group Operation” on page 5-17** for more information.

Rear Panel Interconnects

The A23 test set motherboard includes the following rear panel interconnects.

TEST SET I/O	<p>A DB-25 female connector that is used to control external test sets. The external test set bus consists of 13 multiplexed address and data lines, three control lines, and an open-collector interrupt line. Pin assignments are listed in Table 5-2 on page 5-14.</p> <p>Up to 16 test sets may be “daisy-chained” on the bus at one time.</p> <p>The Test Set I/O is not compatible with 8753 network analyzer test sets.</p>
HANDLER I/O	<p>A rectangular 36-pin, female connector providing four independent parallel input/output ports, nine control signal lines, one ground, and a power supply line. This connector has Type 2 output pin assignments as listed in Table 5-3 on page 5-15.</p> <p>All signals are TTL-compatible. Data input/output ports consist of two 8-bit output ports (Port A and Port B) and two 4-bit bidirectional ports (Port C and Port D).</p> <p>Connector settings can be changed using SCPI and COM commands. The settings are not accessible from the front panel.</p>
PWR I/O	<p>A DB-9 female connector. Pin assignments are listed in Table 5-4 on page 5-16.</p>

Table 5-2 TEST SET I/O Connector Pin Assignments

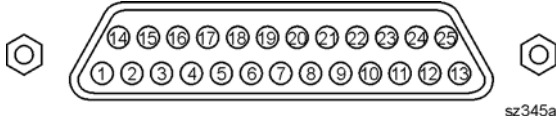

DB-25 Female Connector

Pin Numbers	Name	Function
1	SEL0	TTL out, test set select bit 0, tied to 0 V
2	Sweep Holdoff In	TTL in, low level holds off sweep
3–6	AD12–AD8	TTL I/O, address and latched data
7	GND	0 V, ground reference
8	LAS	TTL out, active low address strobe (1 μ s min)
9–11	AD4–AD2	TTL I/O, address and latched data
12	GND	0 V, ground reference
13	Interrupt In	TTL in, low level (10 μ s min) aborts sweep
14	+22 V	+22 Vdc, 100 mA max.
15–16	SEL1–2	TTL out, test set select bits 1-2, tied to 0 V
17	AD11	TTL I/O, address and latched data
18	SEL3	TTL out, test set select bit 3, tied to 0 V
19–21	AD7–5	TTL I/O, address and latched data
22–23	AD0–1	TTL I/O, address and latched data
24	LDS	TTL out, active low data strobe (1 μ s min)
25	RLW	TTL out, high = read, low = write

Table 5-3 HANDLER I/O Connector Pin Assignments

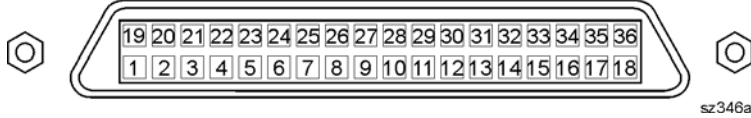

Rectangular 36-Pin Female Connector

Pin Numbers	Name	Function
1	GND	0 V, ground reference
2	INPUT1	TTL in, negative pulse (1 μ s min) latches OUTPUT1-2
3-4	OUTPUT1-2	TTL out, latched
5-12	Port A0-7 Out	TTL out, latched
13-20	Port B0-7 Out	TTL out, latched
21-24	Port C I/O	TTL I/O, latched
25-28	Port D I/O	TTL I/O, latched
29	Port C Status	TTL out, low = input mode, high = output mode
30	Port D Status	TTL out, low = input mode, high = output mode
31	Output Strobe Write Strobe	TTL out, active low data write strobe (1 μ s min)
32	No connect	Not used
33	Pass Fail	TTL out, latched, indicates pass fail (programmable polarity)
34	+5 V	+5 Vdc, 100 mA max.
35	Sweep End	TTL out, active low (10 μ s min) indicates sweep done
36	Pass/Fail Write Strobe	TTL out, active low pass/fail write strobe (1 μ s min)

Table 5-4 PWR I/O Connector Pin Assignments

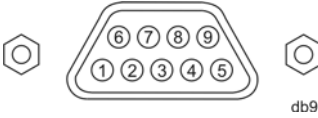
 DB-9 Female Connector		
Pin	Name	Description
1	+15V	+15 V @ 400 mA
2	-15V	-15 V @ 400 mA
3	AnalogOut1	Analog Output Voltage Programmable ± 10 V @ 100 mA out Nominally 0 ohms 2.44 mV typical resolution 1 MHz BW
4	AnalogOut2	Analog Output Voltage Programmable ± 10 V @ 100 mA out Nominally 0 ohms 2.44 mV typical resolution 1 MHz BW
5	ACOM	System ground
6	GndSense	Ground sense for Analog In and Analog Out Connected with 51.1 ohms to ACOM
7	AnalogIn1	Analog input: ± 10 V @ 1.22 mV typical resolution $R_{in} > 1$ M-ohm BW ≈ 1 MHz ADC conversion time < 1 us typical
8	AnalogIn2	Analog input: ± 10 V @ 1.22 mV typical resolution $R_{in} > 1$ M-ohm BW ≈ 1 MHz ADC conversion time < 1 us typical
9	Power Button	Open collector input Active low replicates power button key press.

Signal Separation Group Operation

The signal separation group divides the source incident signals into a reference path and a test path. Refer to [Figure 5-4 on page 5-19](#) and [Figure 5-5 on page 5-20](#).

- The reference signals are transmitted to the receiver group as the R1, R2, R3, and R4 inputs for 4-port models or the R1 and R2 inputs for 2-port models.
- The test signals are transmitted through—and reflected from—the device under test (DUT) and then transmitted to the receiver group as the A, B, C, and D inputs for 4-port models or the A and B inputs for 2-port models.
- Control lines to this group are routed from the A23 test set motherboard.

In this section, the following assemblies are described:

- [A29–A32 Receiver Couplers](#)
- [A33–A36 Test Port Couplers](#)
- Front Panel Jumpers—[Configurable Test Set](#)
- [A38–A41 60-dB Source Step Attenuators and A42–A45 Bias Tees](#)

Configurable Test Set

The configurable test set is included in the standard analyzer and allows you to measure devices with higher power and higher dynamic range limits than an analyzer without the configurable test set. On 4-port models, there are twelve signal paths routed through front panel SMA jumpers in the configurable test set. On 2-port models, there are six signal paths routed through front panels jumpers in the configurable test set.

As shown in [Figure 5-4 on page 5-19](#) and [Figure 5-5 on page 5-20](#), these jumpers are installed between the components listed below. Refer to [Figure 5-6 on page 5-24](#) and [Figure 5-7 on page 5-25](#) for illustrations of the receiver group related front panel jumpers.

- the A29 port 1 receiver coupler and the A27 mixer brick receiver R1
- the A30 port 3 receiver coupler and the A28 mixer brick receiver R3
- the A31 port 4 receiver coupler and the A28 mixer brick receiver R4
- the A32 port 2 receiver coupler and the A27 mixer brick receiver R2
- the A29 port 1 receiver coupler and the A33 test port 1 coupler
- the A30 port 3 receiver coupler and the A34 test port 3 coupler
- the A31 port 4 receiver coupler and the A35 test port 4 coupler
- the A32 port 2 receiver coupler and the A36 test port 2 coupler
- the A33 test port 1 coupler and the A27 mixer brick receiver A
- the A34 test port 3 coupler and the A28 mixer brick receiver C
- the A35 test port 4 coupler and the A28 mixer brick receiver D
- the A36 test port 2 coupler and the A27 mixer brick receiver B

Normal Measurement Configuration

For those models equipped with a configurable test set and source attenuators, with the inclusion of an external amplifier and accessories, you can calibrate the analyzer and test devices at power levels up to

+30 dBm. You can make measurements in the forward, reverse, or both directions and still achieve these high power levels.

High Dynamic Range Measurement Configuration

With a few jumper changes, you can configure the measurement configuration for higher dynamic range measurements. By swapping the front panel jumpers for one port, signal flow through the corresponding coupler is reversed, increasing the test signal sensitivity by 15 dB.

In the forward direction, for example, the signal flow through the test port 2 coupler (A36) is reversed by arranging the front panel jumpers such that RCVR B IN connects to CPLR THRU and CPLR ARM connects to SOURCE OUT.

While increasing forward (S_{21}) dynamic range, the reverse (S_{12}) dynamic range is degraded by the same amount.

A29–A32 Receiver Couplers

The source incident signals from the A5 and A10 26.5 GHz sources are sent to the A29–A32 receiver couplers where a portion of each signal is coupled off to provide the R1, R2, R3, and R4 receiver reference signals for 4-port models or R1 and R2 reference signals for 2-port models.

These reference signals are routed through front-panel jumpers to the A27 and A28 mixer bricks. Refer to [“A27 and A28 Mixer Bricks” on page 5-21](#) for additional information.

The test signals each go through the through-line arm of a receiver coupler, then through a front panel jumper to the A33–A36 test port couplers.

A33–A36 Test Port Couplers

The test signals go into the through-line arm of the couplers, and from there to the test ports and the DUT.

The coupled arm of the couplers carries the signal reflected from or transmitted through the DUT, to the receiver for measurement (through front panel jumpers), as inputs A, B, C, and D for 4-port models or inputs A and B for 2-port models. The coupling coefficient of the directional couplers is nominally 15 dB for all frequencies above 500 MHz. The coupling coefficient increases for frequencies below 500 MHz.

A38–A41 60-dB Source Step Attenuators and A42–A45 Bias Tees

On selected 4-port models, a step attenuator and a bias tee are placed in the signal path of each test port between the A29–A32 receiver couplers and the A33–A36 test port couplers.

On selected 2-port models, a step attenuator and a bias tee are placed in the signal path of each test port between the A29–A32 receiver couplers and the A33–A36 test port couplers.

The 60-dB step attenuators provide coarse power control for the test signals. They are electro-mechanical step attenuators that provide 0 to 60 dB of attenuation in 5-dB steps. They adjust the power level to the DUT without changing the level of the incident power in the reference path. These attenuators are controlled by the A21 CPU board.

The bias tees are to provide DC biasing for the DUT.

Figure 5-4 4-Port Signal Separation Group

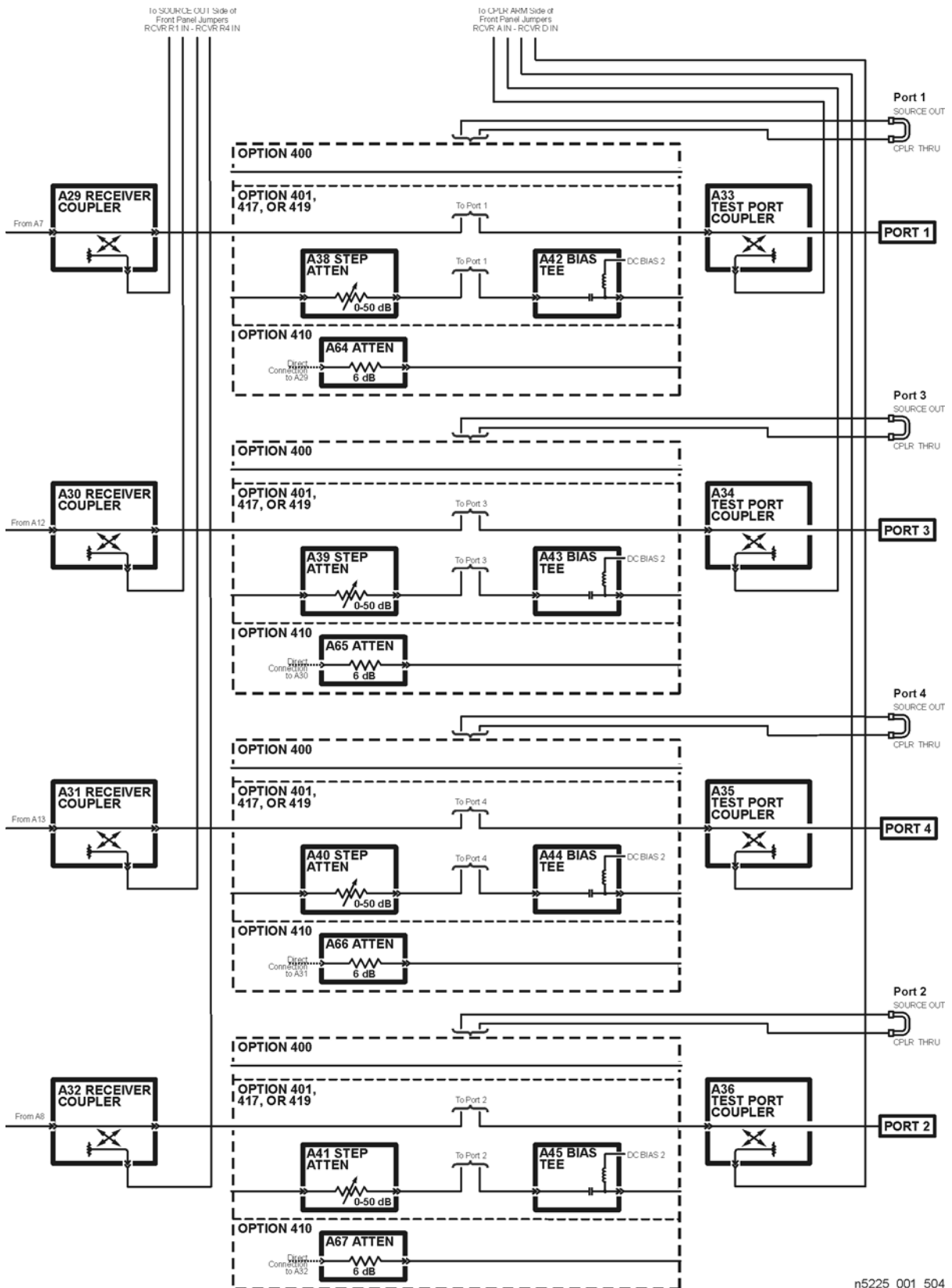

n5225_001_504

Figure 5-5 2-Port Signal Separation Group

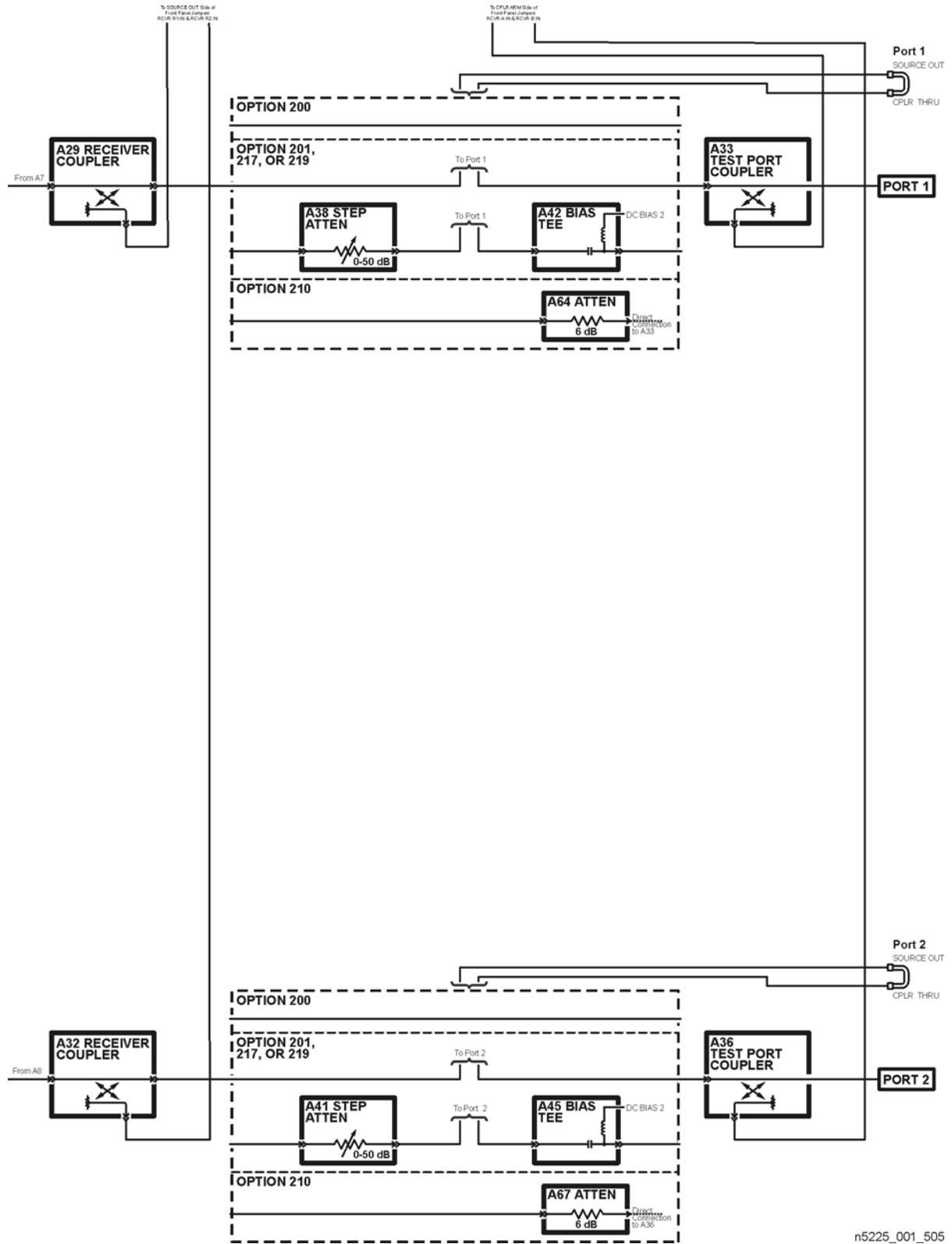

n5225_001_505

Receiver Group Operation

The receiver group measures and processes the input signals into digital information for processing and eventual display. [Figure 5-6 on page 5-24](#) and [Figure 5-7 on page 5-25](#) are simplified block diagrams of the receiver functional group for 2-port and 4-port models.

In this section the following assemblies are described:

- [A46–A49 35-dB Receiver Step Attenuators](#)
- [A37 Reference Mixer Switch](#)
- [A27 and A28 Mixer Bricks](#)
- [A24 IF Multiplexer Board](#)
- [A16 SPAM Board \(Analog Description\)](#)

A46–A49 35-dB Receiver Step Attenuators

A step attenuator is placed in the signal path of each of the A, B, C, and D receiver inputs for 4-port models and A and B receiver inputs for 2-port models.

These 35-dB step attenuators provide power control for the input signals to the mixer bricks. They are electro-mechanical step attenuators that provide 0 to 35 dB of attenuation in 5-dB steps. These attenuators are controlled by the A21 CPU board.

A37 Reference Mixer Switch

The A37 reference mixer switch is placed in the R1 reference signal path allowing this reference signal to be switched in and out of the signal path when an external mixer is being used in test configuration.

An external mixer is placed in measurement configuration between REFERENCE 1 SOURCE OUT and RCVR R1 IN where there would normally be a front panel jumper. The A37 reference mixer switch can then be used to switch this external mixer in and out of the measurement configuration without having to manually connect/disconnect the external mixer and remove/replace the front panel jumper.

A27 and A28 Mixer Bricks

Each of these assemblies contain four identical amplifiers, mixers, and filters for a total of eight of each. For 2-port models, only the A27 mixer brick is present; the A28 mixer brick is omitted since only four receivers are needed.

For frequencies at or above 53 MHz, the test signals (receivers A, B, C, and D for 4-port models and A and B for 2-port models) and the reference signals (receivers R1, R2, R3, and R4 for 4-port models and R1 and R2 for 2-port models) are mixed with a synthesized LO signal that is 7.438 MHz higher than the source incident signal to produce a 7.438 MHz IF signal. This synthesized LO comes from the A25 HMA26.5 (via the A26 splitter for 4-port models).

At frequencies below 53 MHz, the IF is set to 0.826 MHz.

The analog IF signal is sent to the A24 IF multiplexer board where it is amplified and then sent to the A16 SPAM board.

The A27 mixer brick sends the EXT TSET DRIVE LO OUT signal to a rear-panel connector for use with an external test set. This same output connector on the A28 mixer brick is terminated.

A16 SPAM Board (Analog Description)

The A16 SPAM board contains digital and analog circuitry. For digital descriptions, refer to [“A16 SPAM Board \(Digital Description\)” on page 5-29](#).

In this assembly, the IF signals (A, B, C, D, and R for 4-port models and A, B, R1, and R2 for 2-port models) from the A24 IF multiplexer board go through a gain stage where small signals are amplified to ensure that they can be detected by the analog-to-digital converter (ADC).

All input signals are sampled simultaneously by the ADCs, where they are converted to digital form. The ADC conversions are triggered by timing signals from the digital signal processor (DSP) in response to commands from the central processing unit (CPU). The digitized data is processed into magnitude and phase data by the DSP and sent to the CPU random access memory (RAM) by way of the peripheral component interconnect (PCI) bus.

The processed and formatted data is finally routed to the display, and to the general-purpose interface bus (GPIB) for remote operation. Refer to [“Digital Processing and Digital Control Group Operation” on page 5-26](#) for more information on signal processing.

A24 IF Multiplexer Board

This assembly provides pulse modulation capability and routes the IF signal out through the rear panel connectors for external use and routes external signals in through rear panel connectors to be included in the signal processing.

In this assembly, on 4-port models, a single reference signal is selected from R1, R2, R3, and R4 to be sent on to the A16 SPAM. On 2-port models the R1 and R2 reference signals are sent to the A16 SPAM.

The analog IF signals (A, B, C, D, and R for 4-port models and A, B, R1, and R2 for 2-port models) are sent to the A16 SPAM board where they are converted to digital information.

Rear Panel Interconnects

The A24 IF multiplexer board includes the following rear panel interconnects.

PULSE I/O	A DB-15 female connector. Pin assignments are listed in Table 5-5 on page 5-23 .
------------------	--

Table 5-5 PULSE I/O Connector Pin Assignments

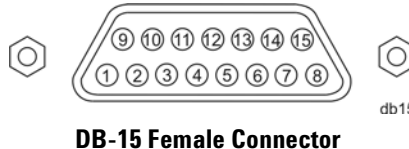

DB-15 Female Connector

Pin	Name	Description
1	IFGateAin	IF pulse gate input A (TTL)
2	IFGateBin	IF pulse gate input B (TTL)
3	IFGateCin	IF pulse gate input C (TTL)
4	IFGateDin	IF pulse gate input D (TTL)
5	IFGateRin	IF pulse gate input R (TTL)
6	DCOM	Digital ground
7	PulseSyncln	Pulse generator synchronization trigger input (TTL)
8	RFPulseModIn	RF source pulse modulation drive input (TTL)
9	DCOM	Digital ground
10	Pulse1Out	Programmable pulse train output #1 (TTL)
11	Pulse2Out	Programmable pulse train output #2 (TTL)
12	Pulse3Out	Programmable pulse train output #3 (TTL)
13	Pulse4Out	Programmable pulse train output #4 (TTL)
14	NC	No connect
15	DCOM	Digital ground

Figure 5-6 4-Port Receiver Group

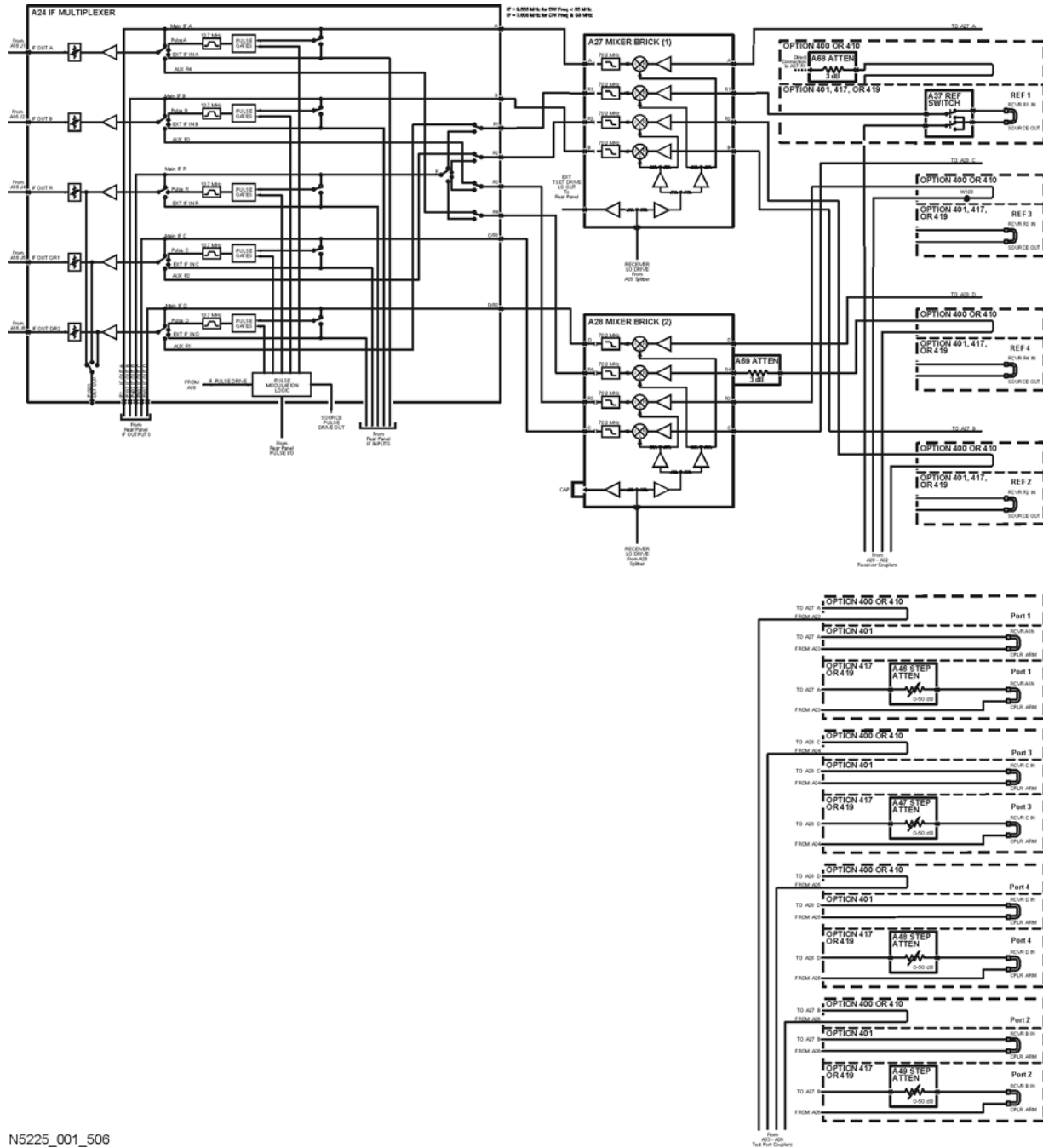

N5225_001_506

Figure 5-7 2-Port Receiver Group

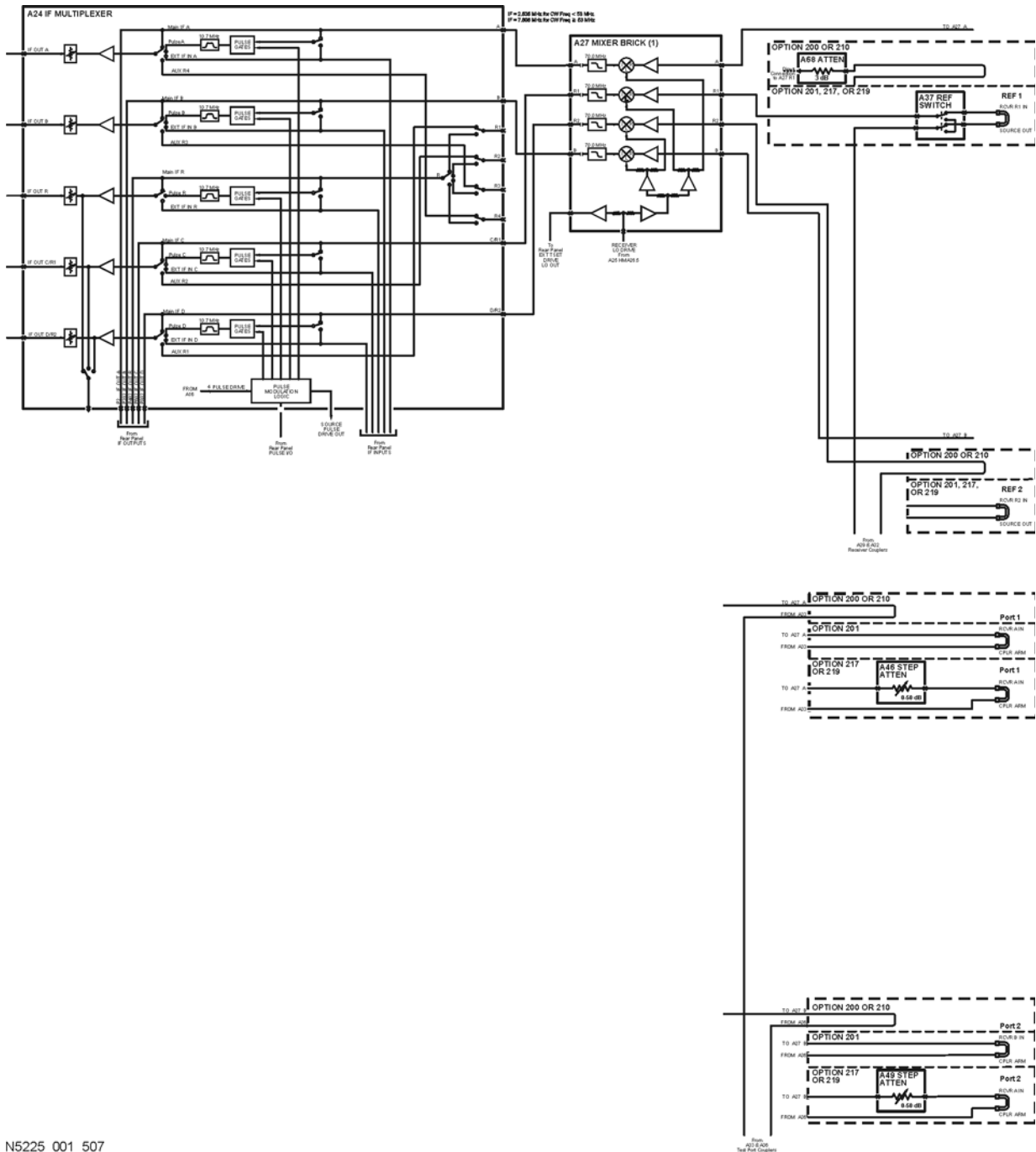

N5225_001_507

Digital Processing and Digital Control Group Operation

The digital processor and control group provides digital control for the entire analyzer. It provides:

- front panel operation,
- output to the display,
- math processing functions, and
- communications between the analyzer and an external controller or peripherals.

A block diagram of the digital control functional group is shown in [Figure 5-8 on page 5-27](#).

The digital control functional group consists of two subgroups:

- **Front Panel Subgroup**
 - A1 Front Panel Display Board
 - A2 USB Board
 - A3 Display Assembly
 - Keypad Assembly
 - A18 System Motherboard
- **Data Acquisition and Processing Subgroup**
 - A16 SPAM Board (Digital Description)
 - A21 CPU Board
 - A55 Solid State Drive (SSD)

Figure 5-8 Digital Processing and Digital Control Group

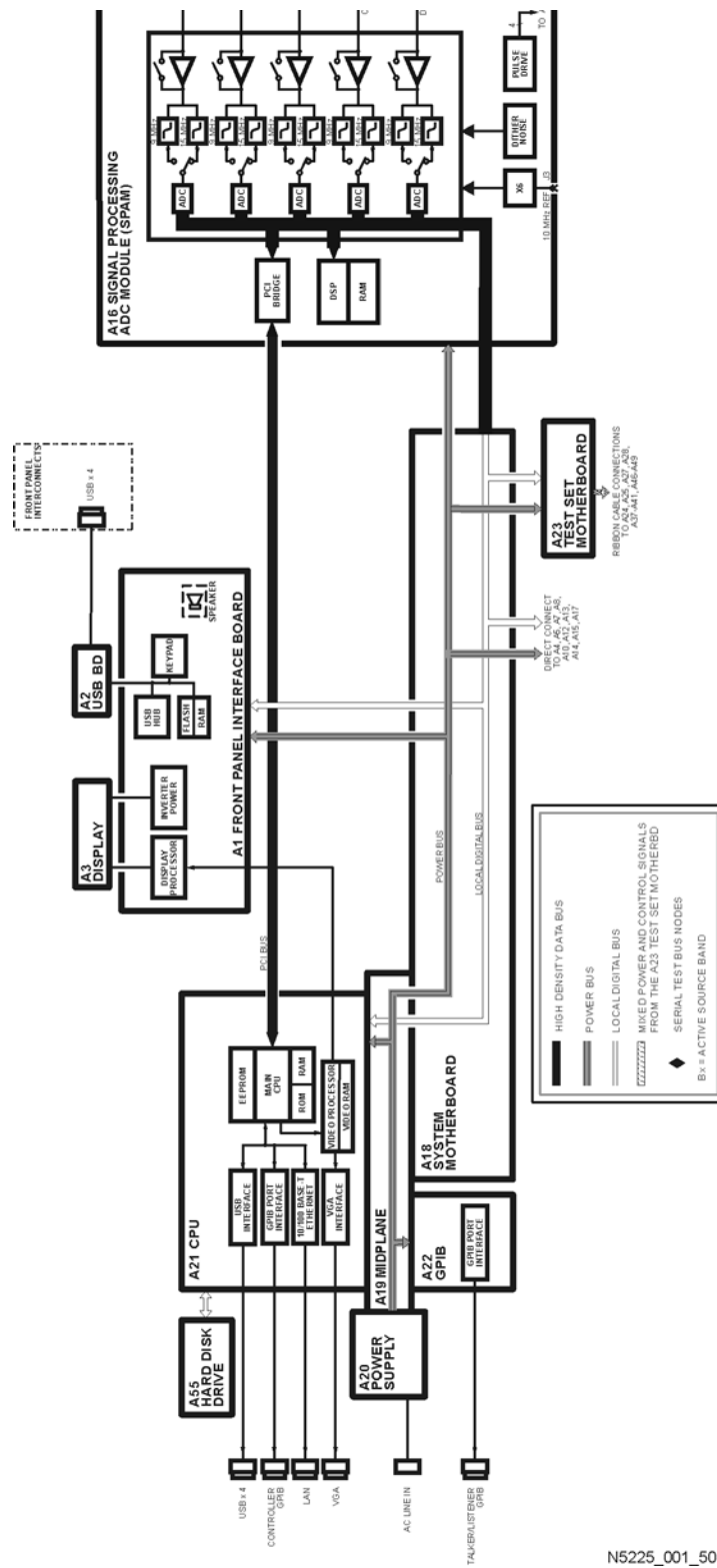

N5225_001_508

Front Panel Subgroup

The front panel subgroup contains the following assemblies:

- [A1 Front Panel Display Board](#)
- [A2 USB Board](#)
- [A3 Display Assembly](#)
- [Keypad Assembly](#)

A1 Front Panel Display Board

The A1 front panel display board detects and decodes user inputs from the keypad assembly and front panel knob, and transmits them to the A21 CPU board by way of the A18 system motherboard. It also decodes video data from the video processor on the A21 CPU board and supplies this to the A3 display assembly. Power from the power bus on the A18 system motherboard is buffered and routed to the keypad assembly and the A3 display assembly. All data and power signals are routed through a single cable connector to the A18 system motherboard.

The A1 front panel interface board also includes a speaker that emits the audio signals received from the A21 CPU board.

A2 USB Board

This board provides four universal serial bus (USB) jacks that are industry standard 4-pin connectors allowing multiple USB devices to be connected to the analyzer's front panel.

A3 Display Assembly

The A3 display assembly contains a 10-inch LCD with associated drive circuitry and backlight inverter. Two cables between the A3 display assembly and the A1 front panel display board provide all necessary power and data for normal operation. The two cables are:

1. A cable to the inverter that supplies buffered power.
2. A cable to the display circuitry that supplies decoded data from the video processor on the A21 CPU board and the necessary drive circuit power. The video data received from the A21 CPU board includes the following:
 - digital TTL horizontal sync
 - digital TTL vertical sync
 - digital TTL red video
 - digital TTL green video
 - digital TTL blue video
 - blanking
 - data clock

Keypad Assembly

The keypad assembly provides user interface to the analyzer. The front panel rotary pulse generator (RPG) knob is not electrically connected to the keypad, but rather provides user inputs directly to the front panel processor.

Data Acquisition and Processing Subgroup

The data acquisition and processing subgroup contain the following assemblies. See [Figure 5-8 on page 5-27](#).

- [A16 SPAM Board \(Digital Description\)](#)
- [A21 CPU Board](#) (including rear-panel interconnects)
- [A55 Solid State Drive \(SSD\)](#)

A16 SPAM Board (Digital Description)

The A16 SPAM board contains digital and analog circuitry. For analog descriptions, refer to [“A16 SPAM Board \(Analog Description\)” on page 5-22](#).

The digital signal processor (DSP) receives digitized data from the digital circuitry of the A16 SPAM board. It computes discrete Fourier transforms to extract the complex phase and magnitude data from the analog IF signal. The resulting raw data is written into the main random access memory (RAM). The data taking sequence is triggered either externally from the rear panel or by firmware on the A21 CPU board.

A21 CPU Board

The A21 CPU board contains the circuitry to control the operation of the analyzer. Some of the components include the central processing unit (CPU), memory (EEPROM, ROM, RAM), bus lines to other board assemblies, and connections to the rear panel. Some of the main components are described next:

- [CPU](#)
- [Main RAM](#)
- [Rear Panel Interconnects](#)

CPU The central processing unit (CPU) is a microprocessor that maintains digital control over the entire instrument through the instrument bus. The CPU receives external control information from the keypad, any USB device, LAN or GPIB, and performs processing and formatting operations on the raw data in the main RAM. It controls the DSP, the video processor, and the interconnect port interfaces. In addition, when the analyzer is in the system controller mode, the CPU controls peripheral devices through the peripheral port interfaces.

Front panel settings are stored in SRAM, with a battery providing at least five years of backup storage when external power is off.

Main RAM The main random access memory (RAM) is shared memory for the CPU and the DSP. It stores the raw data received from the DSP while additional calculations are performed on it by the CPU. The CPU reads the resulting formatted data from the main RAM, converts it to a user-definable display format, and writes this to the video processor for display.

Rear Panel Interconnects The rear panel includes the following interfaces:

USB x4	Four universal serial bus (USB) jacks (industry standard 4-pin connectors).
GPIB (0) Controller	A 24-pin, female, type D-24 connector that meets IEEE-488 standards.
GPIB (1) Talker/Listener	A 24-pin, female, type D-24 connector that meets IEEE-488 standards.
LAN	A standard 8-pin, 10/100BaseT, Ethernet connection. It auto selects between the two data rates.
Display (VGA)	A 15-pin, female, D-sub connector that provides a video output of the analyzer display that can be viewed on an external VGA monitor.

A55 Solid State Drive (SSD)

The SSD is a Serial Advanced Technology Attachment (SATA) data storage device which is connected directly to, and physically mounted within the enclosure of, the A21 CPU board. The full operating system and firmware for the network analyzer is stored on the A55 SSD.

Power Supply Group Operation

The A20 power supply assembly is a switching power supply operating at 103 kHz switching frequency. The input power ranges for the power supply are 90 to 132 Vac or 195 to 250 Vac. The power supply automatically senses the input voltage and switches between these two ranges.

WARNING **Supply voltages which oscillate between the two normal input ranges of the autoranging line voltage input will damage the power supply. In rare cases, this damage has become a user safety concern. If unstable power levels are expected, the analyzer input power must be buffered by a line conditioner.**

The dc output voltages of the A20 power supply assembly are:

- +15 V analog
- +9 V analog
- +3.3 V analog
- +5.2 V analog
- +15 V standby (always on)
- +32 V analog
- –15 V analog
- –5.2 V analog
- –7 V analog
- +5.1 V standby
- +12 V digital
- +3.35 V digital
- +5.1 V digital

The +15 V standby supply remains on continuously whenever the power supply is plugged in. This supply is used to provide power to front panel LEDs and CPU components when the analyzer is turned off.

6 Replaceable Parts

This page is intentionally left blank.

Information in This Chapter

This chapter:

- identifies the replaceable parts for the Keysight PNA series microwave network analyzer.
- includes several tables and illustrations to assist you in identifying the correct part for your analyzer.
- contains ordering information for new assemblies and rebuilt-exchange assemblies.

Chapter Six at-a-Glance

Section Title	Summary of Content	Start Page
Ordering Information	How to order a replaceable part from Keysight Technologies.	Page 6-4
Assembly Replacement Sequence	The correct sequence for replacing a defective assembly.	Page 6-4
Rebuilt-Exchange Assemblies	The definition of a rebuilt-exchange assembly. The procedure for replacing and returning a defective assembly to Keysight Technologies.	Page 6-5
Replaceable Parts Listings	Tables that list the assemblies by reference designator with their associated part number and description. Illustrations that indicate the location of each of the replaceable parts in your analyzer: <ul style="list-style-type: none">• Assemblies (front panel, top, bottom, and rear panel)• Cables (top and bottom)• Hardware (top, bottom, internal, and external.)• Miscellaneous replaceable parts	Page 6-6

Ordering Information

To order a part listed in the replaceable parts lists:

- include the part number
- indicate the quantity required
- Contact Keysight Technologies for instructions on where to send the order. Refer to [“Contacting Keysight” on page 2-8.](#)

To order a part that is not listed in the replaceable parts lists:

- include the instrument model number and complete instrument serial number
- include the description and function of the part
- indicate the quantity required
- Contact Keysight Technologies for instructions on where to send the order. Refer to [“Contacting Keysight” on page 2-8.](#)

Assembly Replacement Sequence

The following steps describe how to replace an assembly in the network analyzer.

- Step 1.** Identify the faulty group. Begin with [Chapter 4, “Troubleshooting.”](#) Follow up with the appropriate troubleshooting chapter that identifies the faulty assembly.
- Step 2.** Order a replacement assembly. Refer to this chapter.
- Step 3.** Replace the faulty assembly and determine what adjustments are necessary. Refer to [Chapter 7, “Repair and Replacement Procedures.”](#)
- Step 4.** Perform the necessary adjustments. Refer to [Chapter 3, “Tests and Adjustments.”](#)
- Step 5.** Perform the necessary performance tests. Refer to [Chapter 3, “Tests and Adjustments.”](#)
- Step 6.** Keysight personnel: see [Figure 1-1 on page 1-5](#) to review where the calibration stickers should be placed on the PNA.

Rebuilt-Exchange Assemblies

Under the rebuilt-exchange assembly program:

- Certain factory-repaired and tested assemblies are available on a trade-in basis.
- Exchange assemblies are offered for lower cost than a new assembly, but meet all factory specifications required of a new assembly.
- The defective assembly must be returned for credit under the terms of the rebuilt-exchange assembly program.
- Spare assembly stock desired should be ordered using the new assembly part number.

Figure 6-1 Module Exchange Procedure

The module exchange program described here is a fast, efficient, economical method of keeping your instrument in service.

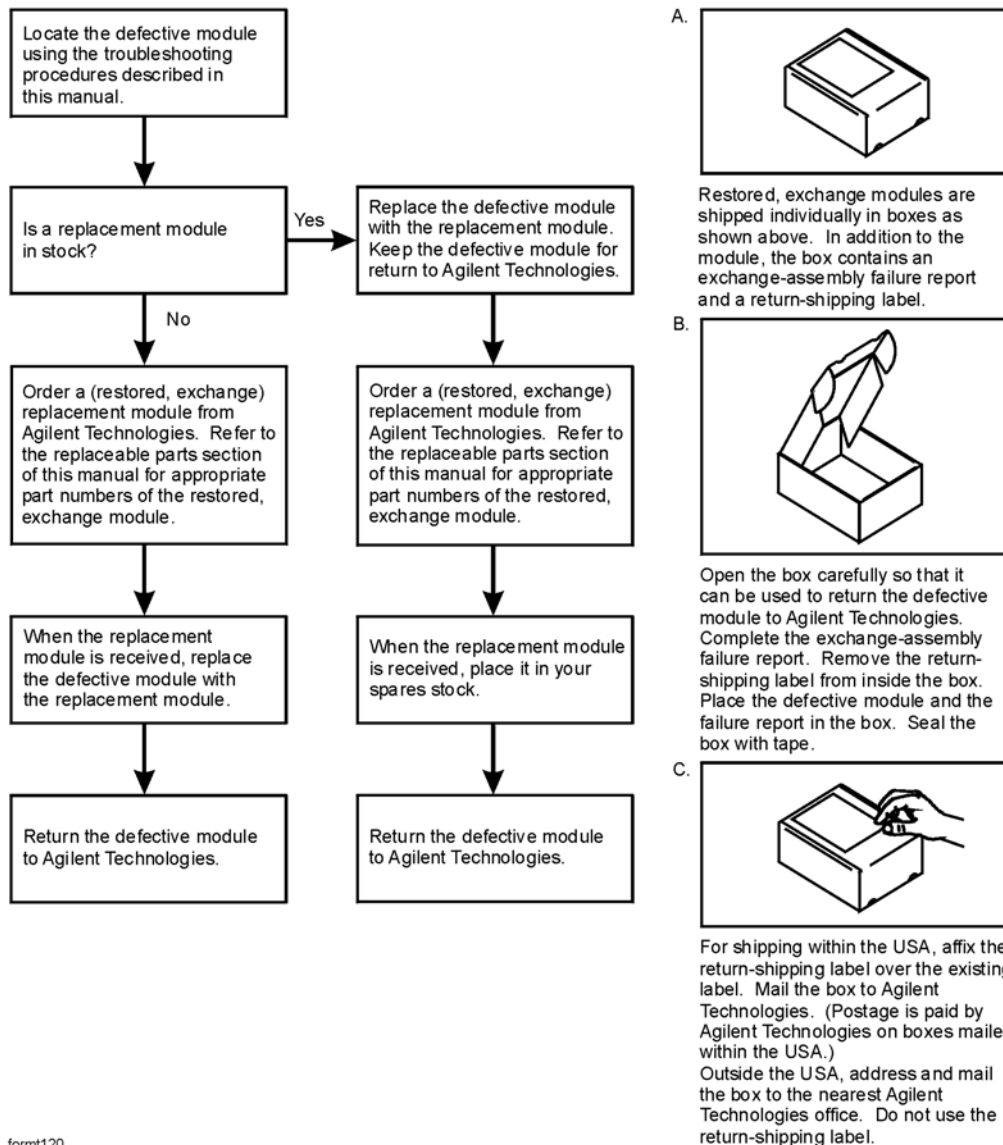

formt120

Replaceable Parts Listings

This section contains the replacement part numbers and their descriptions for your Keysight microwave PNA. You can find the locations of replaceable parts in this section:

- listed by reference designator in [Table 6-1](#), or
- listed by the type of part in [Table 6-2](#).

Table 6-1 Part Number Listing by Reference Designator

Reference Designator	Description	Location
A1	Front panel interface board	"Front Panel Assembly, Back Side, All Options" on page 6-12
A2	USB board	
A3	Display assembly	
A4	13.5 GHz source 1 synthesizer board	"Top Assemblies and Cables, All Options" on page 6-16
A5	26.5 GHz source board 1	
A6	Not used	
A7	Doubler 1 board	
A8	Doubler 2 board	
A9	Noise receiver board	
A10	26.5 GHz source board 2	
A11	Not used	
A12	Doubler 3 board	
A13	Doubler 4 board	
A14	Frequency reference board	
A15	13.5 GHz (LO) synthesizer board	
A16	Signal processing ADC module (SPAM) board	
A17	13.5 GHz source 2 synthesizer board	
A18	System motherboard	
A19	Midplane board	
A20	Power supply	
A21	CPU board	
A22	GPIB board	

Table 6-1 Part Number Listing by Reference Designator (Continued)

Reference Designator	Description	Location
A23	Testset motherboard	Your option set determines which assemblies are in your PNA. Refer to "Bottom Assemblies and Cables by Option Set:" in Table 6-2 on page 6-9
A24	IF multiplexer board	
A25	LO Multiplier/amplifier 26.5 (HMA26.5)	
A26	Splitter	
A27	Mixer Brick 1	Your option set determines which assemblies are in your PNA. Refer to "Bottom Assemblies and Cables by Option Set:" in Table 6-2 on page 6-9.
A28	Mixer Brick 2	
A29	Port 1 receiver coupler	
A30	Port 3 receiver coupler	
A31	Port 4 receiver coupler	
A32	Port 2 receiver coupler	
A33	Port 1 test port coupler	
A34	Port 3 test port coupler	
A35	Port 4 test port coupler	
A36	Port 2 test port coupler	
A37	Reference mixer switch	
A38	Port 1 source step attenuator	
A39	Port 3 source step attenuator	
A40	Port 4 source step attenuator	
A41	Port 2 source step attenuator	
A42	Port 1 bias tee	
A43	Port 3 bias tee	
A44	Port 4 bias tee	
A45	Port 2 bias tee	
A46	Port 1 receiver step attenuator	
A47	Port 3 receiver step attenuator	
A48	Port 4 receiver step attenuator	
A49	Port 2 receiver step attenuator	
A55	Hard disk drive	"Top Assemblies and Cables, All Options" on page 6-16

Table 6-1 Part Number Listing by Reference Designator (Continued)

Reference Designator	Description	Location
A64	Test port 1 6-dB attenuator	Your option set determines which assemblies are in your PNA. Refer to "Bottom Assemblies and Cables by Option Set:" in Table 6-2 on page 6-9.
A65	Test port 3 6-dB attenuator	
A66	Test port 4 6-dB attenuator	
A67	Test port 2 6-dB attenuator	
A68	REF 1 RCVR R1 IN 3 dB attenuator	
A69	REF 4 RCVR R4 IN 3 dB attenuator	

Table 6-2 Part Number Listing by Type of Part

Assemblies and Cables

- “Front Panel Assembly, Front Side, All Options” on page 6-10
- “Front Panel Assembly, Back Side, All Options” on page 6-12
- Top Assemblies and Cables, All Options:
 - ❑ “Top Assemblies, All Options” on page 6-16
 - ❑ “Top Cables, All Cables—All Options” on page 6-20
- Bottom Assemblies and Cables by Option Set:
 - ❑ “2-Port Configuration, Option 200” on page 6-22
 - ❑ “2-Port Configuration, Option 201” on page 6-28
 - ❑ “2-Port Configuration, Option 210” on page 6-34
 - ❑ “2-Port Configuration, Option 217” on page 6-40
 - ❑ “2-Port Configuration, Option 219” on page 6-46
 - ❑ “4-Port Configuration, Option 400” on page 6-52
 - ❑ “4-Port Configuration, Option 401” on page 6-58
 - ❑ “4-Port Configuration, Option 410” on page 6-64
 - ❑ “4-Port Configuration, Option 417” on page 6-70
 - ❑ “4-Port Configuration, Option 419” on page 6-78
- “Rear Panel Assembly, All Options” on page 6-86

Hardware

- “Fan Assemblies, All Options” on page 6-88
- “Top Hardware and Miscellaneous Parts, All Options” on page 6-90
- “Bottom Hardware and Miscellaneous Parts” on page 6-92
- “Internal Hardware and Miscellaneous Parts, All Options” on page 6-94
- “External Hardware and Miscellaneous Parts, All Options” on page 6-96

Miscellaneous

- Service Tools on page 6-98
- Documentation on page 6-98
- GPIB Cables/GPIB Adapter on page 6-98
- Fuses on page 6-98
- Battery on page 6-98
- Analyzer Accessories on page 6-99
- USB Accessories on page 6-99
- ESD Supplies on page 6-99
- Rack Mount Kits and Handle Kits on page 6-99

Front Panel Assembly, Front Side, All Options

NOTE The N5245-60024 (Was N5247-60004) 2-port front panel assembly and the N5245-60022 (Was N5247-60005) 4-port front panel assembly contain the items shown in the following table.

Reference Designator	Part Number	Qty	Description
①	N5247-20137	1	Front frame, 2-port (frame only, not the assembly)
	N5247-20141		Front frame, 4-port (frame only, not the assembly)
	8160-0660	1.2 m	RFI gasket material, 1.2 meters in length (Must be ordered separately from front frame.)
②	0515-2044	--	Machine screw, M4.0 x 10 flat head (To attach front frame to chassis.)
③ ^a	5041-9176	2	Trim strip, filler (For analyzers with handles.)
④	N5242-80005	1	Keypad overlay
⑤	N5227-80008	1	Front panel overlay, 2-port (Option 200)
	N5227-80009		Front panel overlay, 2-port (Option 201)
	N5227-80002		Front panel overlay, 2-port (Option 210)
	N5225-80002		Front panel overlay, 2-port (Option 217)
	N5227-80009		Front panel overlay, 2-port (Option 219)
	N5227-80004		Front panel overlay, 4-port (Options 400)
	N5227-80005		Front panel overlay, 4-port (Options 401)
	N5227-80003		Front panel overlay, 4-port (Options 410)
	N5225-80003		Front panel overlay, 4-port (Options 417)
	N5227-80005		Front panel overlay, 4-port (Options 419)
⑥	N5242-80007	1	Power switch overlay
⑦	W1312-40017	1	Front (RPG) knob
⑧	N5224-80001	1	Nameplate, N5224A
	N5225-80001		Nameplate, N5225A
⑨	0515-1946	--	Machine screw, M3.0 x 6, 90-deg flat head (To attach front fame to sub panel.) (Only 2 used on 2-port, all 4 used on 4-port.)
Not shown	5023-1399	2	Front handle

a. Refer to **“Rack Mount Kits and Handle Kits”** on page 6-99 for part numbers of complete rack mount kits.

Figure 6-2 Front Panel Assembly, Front Side, All Options

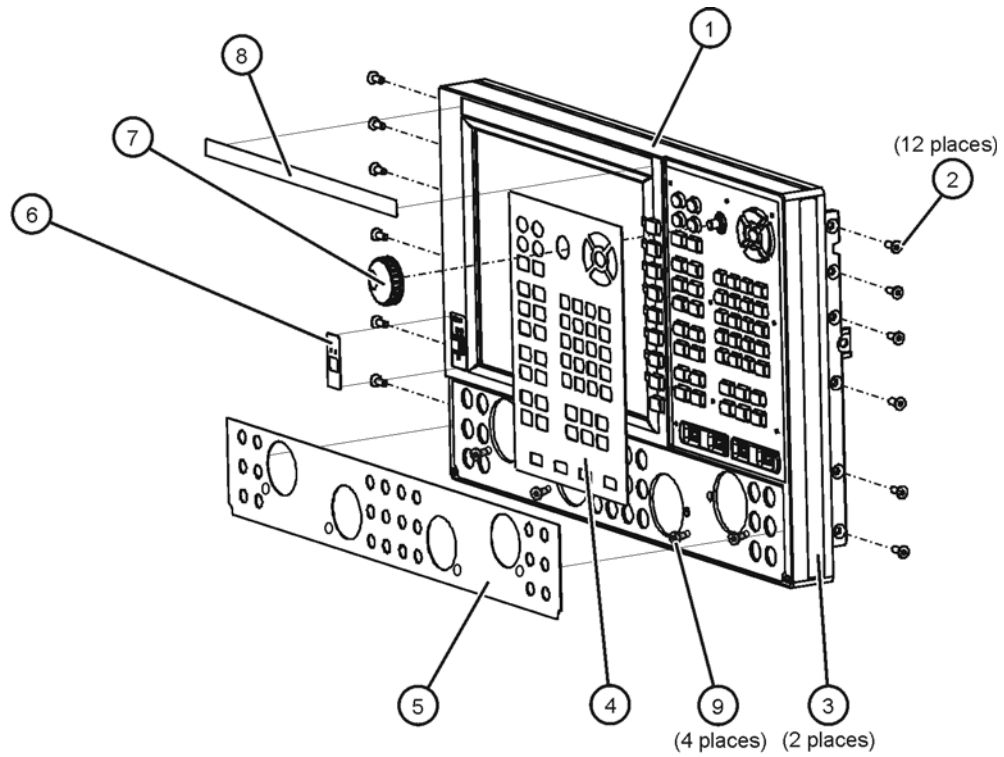

n5225_001_601

Front Panel Assembly, Back Side, All Options

Reference Designator	Part Number	Qty	Description
A1	N5240-60065 Was N5240-60046	1	Front panel interface board
A2	N5240-60063 Was N5240-60047	1	USB board
Not shown	N5242-60010	1	Ribbon cable, 60-wire, A18 system motherboard J9 to A1 front panel interface board J1
①	N5242-40001	1	Keypad assembly
②	0515-0430	--	Machine screw, M3.0 x 6 pan head (9 to attach front panel interface board to front frame) and 3 to attach display cable to display hold down bracket.)
③	N5242-40009 Was N5240-40003	1	Touch screen rubber boot
④	2090-1045 Was 2090-0973	1	Touch screen, 10.4 inch
⑤	0515-0372	--	Machine screw, M3.0 x 8 pan head (6 to attach display to front frame, 6 to attach LCD display assy to bracket, and 4 to attach USB board to front frame.)
⑥	E6601-61028	1	Cable, A3 front panel interface board to inverter board
⑦	0515-1934	--	Machine screw, M2.5 x 6 pan head (To attach inverter board and USB controller board to display hold down bracket.)
⑧ ^a critical footnote	0950-5396 (LED) 0950-4420 (Tube)	1	Inverter board
⑨	0960-3063 Was 0960-2804	1	Touch screen controller board
⑩	0515-1521	--	Machine screw, M3.0 x 5 flat head (To attach power switch assembly to front frame.)
⑪	N5240-60064 Was N5240-60050	1	Power switch board
⑫	N5240-40001	1	Power button keypad
⑬	W1312-60047 Was 8121-1452	1	Touch screen controller board cable harness
⑭	8121-1451	1	Power switch cable harness
⑮	1400-0510	2	Cable clamp (with adhesive backing)
⑯	0515-0667	1	Machine screw, M3.0 x 25 pan head (To attach display to front frame.)
⑰	2190-0017	1	Lock washer, helical #8 (To use with 0515-0667 screw.)
A3			Display assembly:
⑱ ^a critical footnote	0515-2329 (LED) 0515-0664 (Tube)	--	Machine screw, M3.0 x 10 pan head (To attach LCD display to bracket.)
⑲ ^a critical footnote	2090-1036 (LED) 2090-0883 (Tube)	1	LCD display

Reference Designator	Part Number	Qty	Description
A3			Display assembly (continued from previous page):
⑳ ^a critical footnote	N5242-20121 (Tube)	4	Spacers (For display hold down bracket standoffs.) For use with LCD display 2090-0883 only.
㉑ ^a critical footnote	N5242-00044 (LED) N5245-00027 (Tube) Was N5242-00034	1	LCD display rear plate
㉒	N5242-60043	1	LCD display cable
㉓ ^a critical footnote	N5242-20168 (LED)	2	LCD display side bracket
㉔ ^a critical footnote	8121-2132 (LED) 8121-1451 (Tube)	1	Cable assembly for LCD backlight

a. In March 2013, Keysight discontinued using a display with florescent tube backlighting, and began using a display with LED backlighting. Associated parts are indicated in this table with either "Tube" or "LED." If you replace an old part number <designated "Tube"> with its new part number <designated "LED">, you must also replace ALL of the other old part numbers <designated "Tube"> in the table with their new part numbers <designated "LED">.

Figure 6-3 Front Panel Assembly, Back Side, All Options

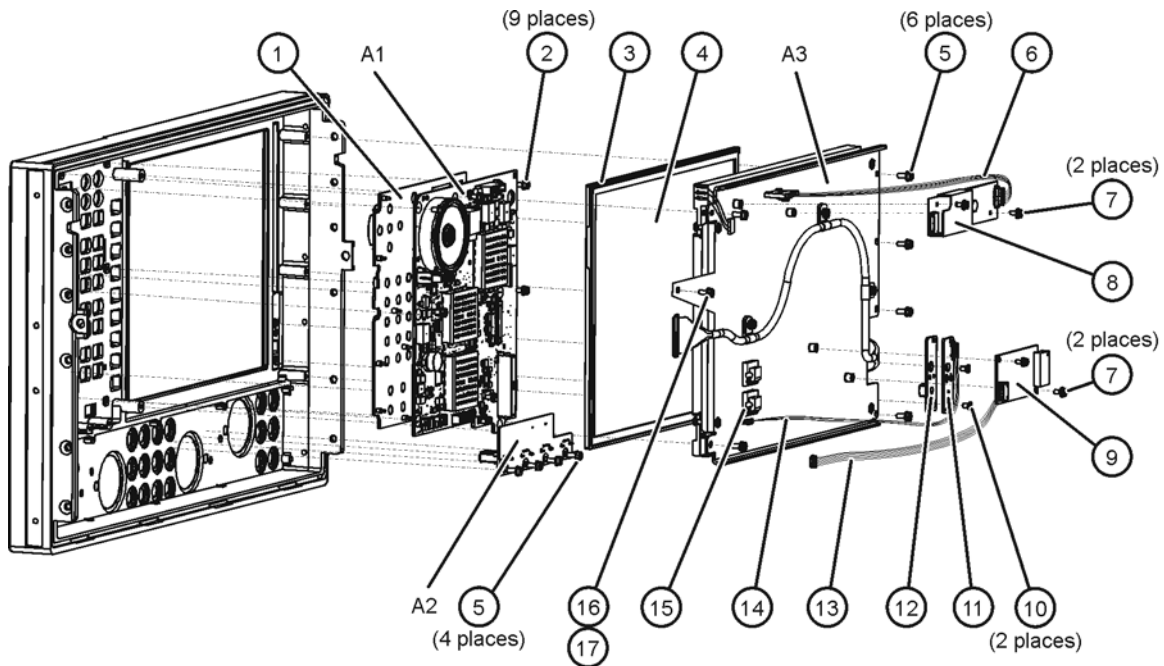

n5242_001_601-2

Figure 6-4 A3 Display Assembly with Old LCD Display 2090-0883

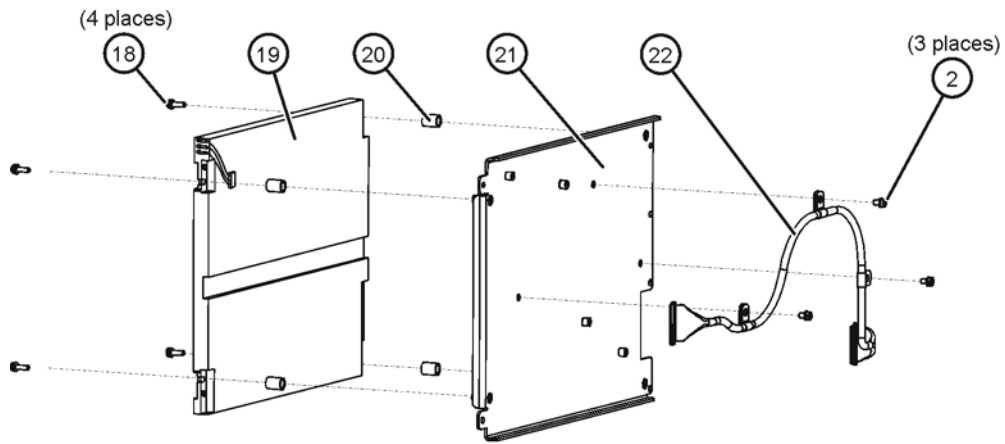

n5242_001_675

Figure 6-5 A3 Display Assembly with New LCD Display 2090-1036

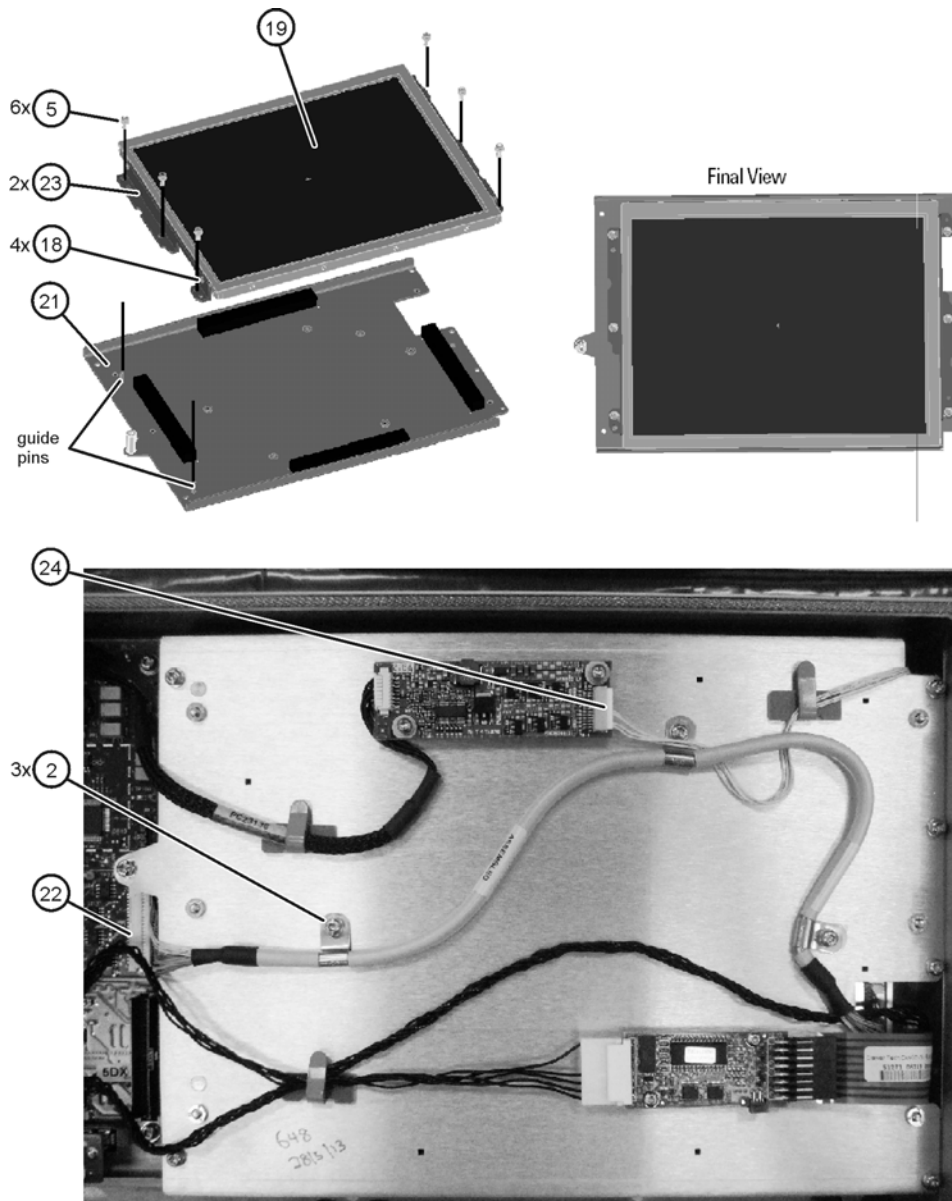

n5242_001_676

Top Assemblies and Cables, All Options

IMPORTANT When replacing an old assembly, install an assembly with either the same part number or the new part number.

Top Assemblies, All Options

Reference Designator	Part Number	Qty	Description
A4	N5240-60074 Was N5242-60150	1	13.5 GHz (source 1) synthesizer board
A5	5087-7342	1	26.5 GHz source (1) board
A6	Not used.		
A7	5087-7349	1	Doubler assembly port 1
A8	5087-7349	1	Doubler assembly port 2
A9	Not used.		
A10	5087-7342	1	26.5 GHz source (2) board
A11	Not used.		
A12	5087-7349	1	Doubler assembly port 3
A13	5087-7349	1	Doubler assembly port 4
A14	N5240-60069	1	Frequency reference board
A15	N5240-60074 Was N5242-60150	1	13.5 GHz (LO) synthesizer board
A16	N5240-60077 Was N5240-60056	1	Signal Processing ADC Module (SPAM) board
A17	N5240-60074 Was N5242-60150	1	13.5 GHz (source 2) synthesizer board
A18	N5247-60002	1	System motherboard
A19	W1312-60095	1	Midplane board
A20	0950-4934	1	Power supply
A21	W1312-60196	1	CPU board assembly, Intel® 2.0 GHz Core® i7 ^a
A22	N5240-60059	1	GPIO board
A55 ^b	N5242-60088	1	Solid state drive assembly (SSDA) for Windows XP Operating System - to be used with the 2.0 GHz CPU board W1312-60196, System CPU version 6 ^c
	N8983A ^d		Solid state drive assembly (SSDA) for Windows 7 Operating System - to be used with the 2.0 GHz CPU board W1312-60196, System CPU version 6 ^c
①	1420-0356	1	Battery, lithium manganese dioxide, 3V, 0.22A-hr. ^e
②	1810-0118	1	50-ohm load

a. For the latest information on CPUs and associated drives, visit na.support.keysight.com/pna/hdnumbers.html.

- b. The A55 hard disk drive is located inside the A21 CPU board assembly. Refer to “**Removing and Replacing the A1–A3 and Other Front Panel Subassemblies**” on page 7-10 for an illustration.
- c. You can learn your System CPU version using the PNA software. On the PNA front panel, press **Help > About Network Analyzer**. In the window displayed, find “System CPU Version.”
- d. For more information on the N8983A SSD, refer to the *Windows 7 Operating System Upgrade Kit Installation Note*, available online at <http://literature.cdn.keysight.com/litweb/pdf/N8983-90001.pdf>.
- e. The lithium battery is located inside the A21 CPU board assembly. Refer to “**Removing and Replacing the Lithium Battery**” on page 7-54 for an illustration.

Figure 6-6 Top Assemblies, All Options

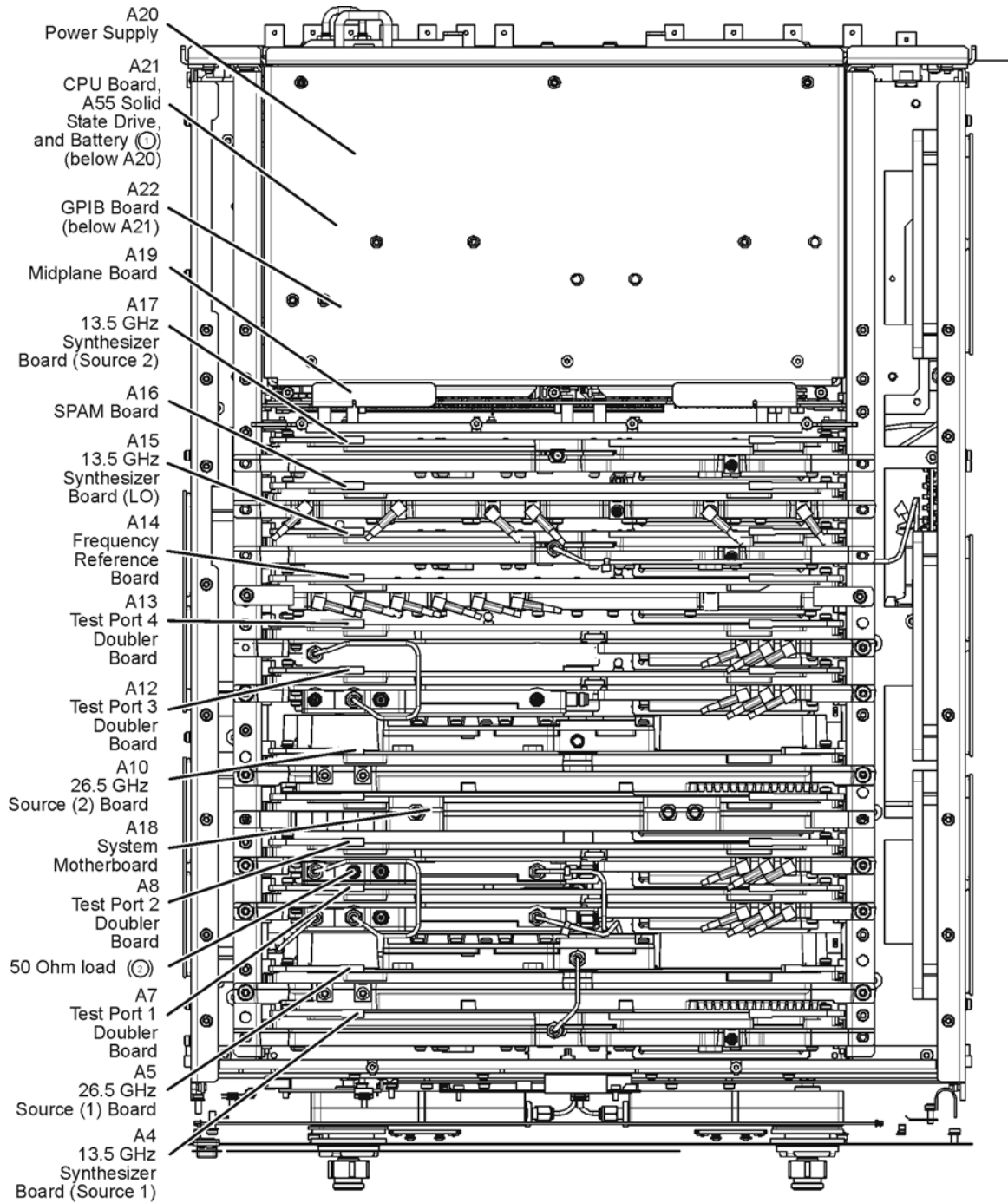

(Some parts removed for clarity.)

N5225_001_602

This page is intentionally left blank.

Top Cables, All Cables—All Options

Ref. Desig.	Type ^a	Part Number	Qty	Description
W1	SR	N5245-20114	1	A4 13.5 GHz (source 1) synthesizer board J1207 to A5 26.5 GHz source (1) board P1
W2	SR	N5245-20100	1	A10 source (2) P1 to A17 13.5 GHz source (2) synthesizer J1207
W3	SR	N5245-20034	1	A5 source (1) P5 to A7 port 1 doubler
W4	SR	N5245-20035	1	A5 source (1) P3 to A8 port 2 doubler
W5	SR	N5245-20032	1	A5 source (1) P4 to A7 port 1 doubler
W6	SR	N5245-20033	1	A7 port 1 doubler to A8 port 2 doubler
W7	SR	N5245-20034	1	A10 source (2) P5 to A12 port 3 doubler
W8	SR	N5245-20035	1	A10 source (2) P3 to A13 port 4 doubler
W9	SR	N5245-20032	1	A10 source (2) P4 to A12 port 3 doubler
W10	SR	N5245-20033	1	A12 port 3 doubler to A13 port 4 doubler
W11	SR	N5245-20036	1	A7 port 1 doubler to W12 (2-port) or W105 (4-port)
W13	SR	N5245-20036	1	A12 port 3 doubler to W14 (2-port) or W111 (4-port)
W15	SR	N5245-20036	1	A13 port 4 doubler to W16 (2-port) or W115 (4-port)
W17	SR	N5245-20036	1	A8 port 2 doubler to W18 (2-port) or W119 (4-port)
W51	SR	N5245-20101	1	A15 13.5 GHz (LO) synthesizer board J1207 to A25 HMA26.5
W55	SR	N5245-20102	1	A7 port 1 doubler to W56 (located on bottom of board)
W69	F	N5242-60012	1	A24 IF multiplexer board P3 to A16 SPAM board J1
W70	F	N5242-60013	1	A24 IF multiplexer board P203 to A16 SPAM board J2
W71	F	N5242-60014	1	A24 IF multiplexer board P403 to A16 SPAM board J4
W72	F	N5242-60015	1	A24 IF multiplexer board P603 to A16 SPAM board J5
W73	F	N5242-60016	1	A24 IF multiplexer board P803 to A16 SPAM board J6
W74	F	N5242-60027	1	A14 frequency reference board J4 to A16 SPAM board J3
W75	F	N5242-60028	1	A14 frequency reference board J5 to A15 13.5 GHz (LO) synthesizer board J5 (Located on bottom of board.)
W76	F	N5242-60029	1	A14 frequency reference board J6 to A4 13.5 GHz (source 1) synthesizer board J5 (Located on bottom of board.)
W77	F	N5242-60030	1	A14 frequency reference board J7 to A17 13.5 GHz (source 2) synthesizer board J5 (Located on bottom of board.) (4-port only.)
W78	F	8120-5063	2	A14 frequency reference board J3 to rear-panel 10 MHz REF OUT
W79				Rear-panel 10 MHz REF IN to A14 frequency reference board J2
W149	F	N5247-60023	1	A24 IF multiplexer board P603 to A16 SPAM board J2
W150	F	N5247-60024	1	A24 IF multiplexer board P203 to A16 SPAM board J5

a. SR = semirigid coaxial cable; F = flexible coaxial cable; nR = n wires in a ribbon (flat) cable; nW = n wires in a wire harness

Figure 6-7 Top Cables, All Cables—All Options

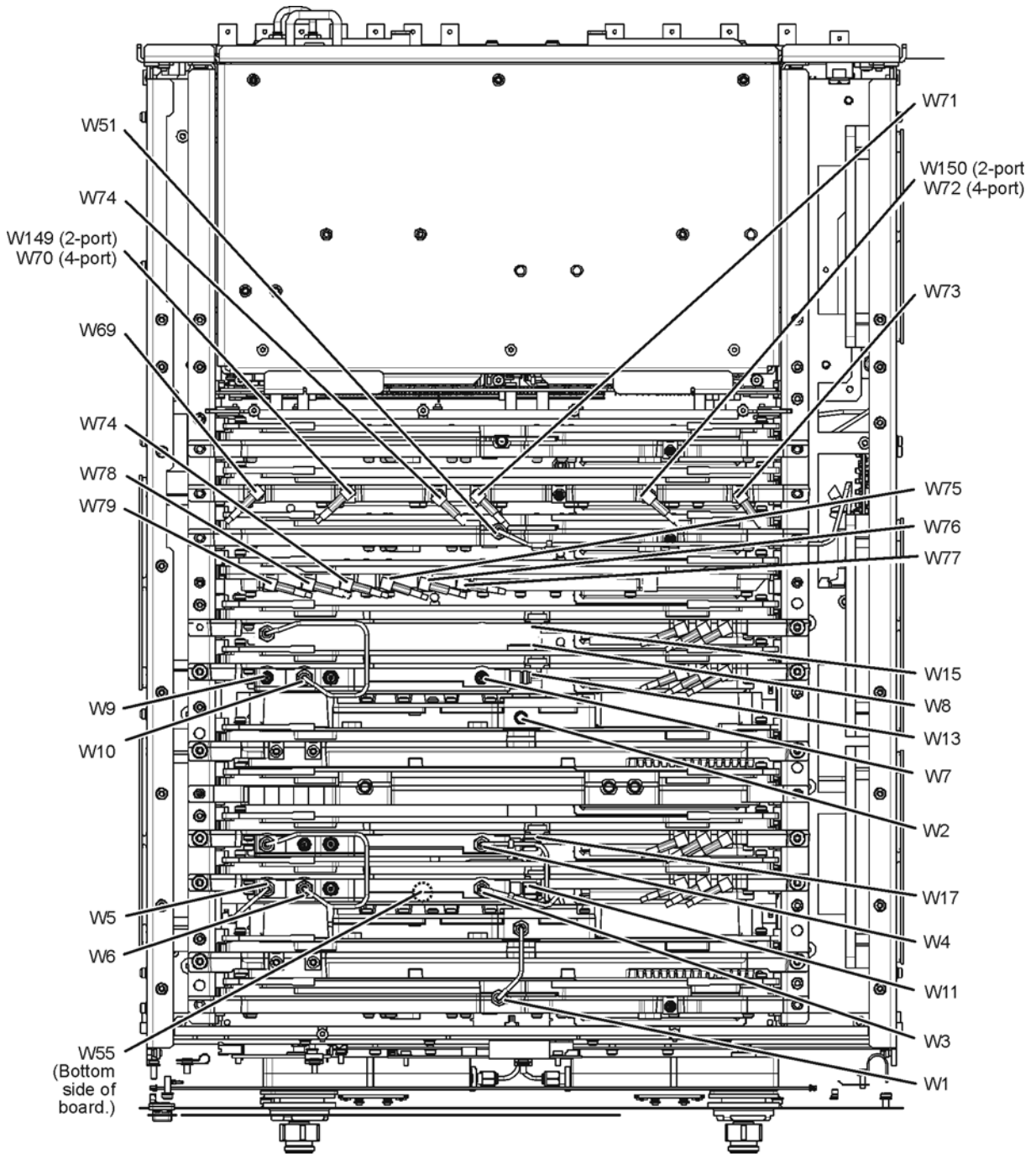

(Some parts removed for clarity.)

N5225_001_603

2-Port Configuration, Option 200

Bottom Assemblies, Standard 2-Port Configuration, Option 200

Reference Designator	Part Number ^a	Qty	Description
A23	N5245-60157 <i>Was N5247-60001</i>	1	Test set motherboard
A24	N5240-60062	1	IF multiplexer board
A25	5087-7765	1	LO Multiplier/amplifier 26.5 (HMA26.5)
A27	5087-7323 <i>5087-6323</i>	1	Mixer brick
A29 A32	5087-7760	2	Test port 1 receiver coupler Test port 2 receiver coupler
A33 A36	5087-7793	2	Test port 1 coupler Test port 2 coupler
①	N5240-60058	2	Front panel LED board
A68	08490-60039	1	3 dB attenuator (pad) connected to mixer brick (R1)

- a. Part numbers in italic typeface are for rebuilt exchange assemblies. Refer to ["Rebuilt-Exchange Assemblies"](#) on [page 6-5](#).

Figure 6-8 Bottom Assemblies, Standard 2-Port Configuration, Option 200

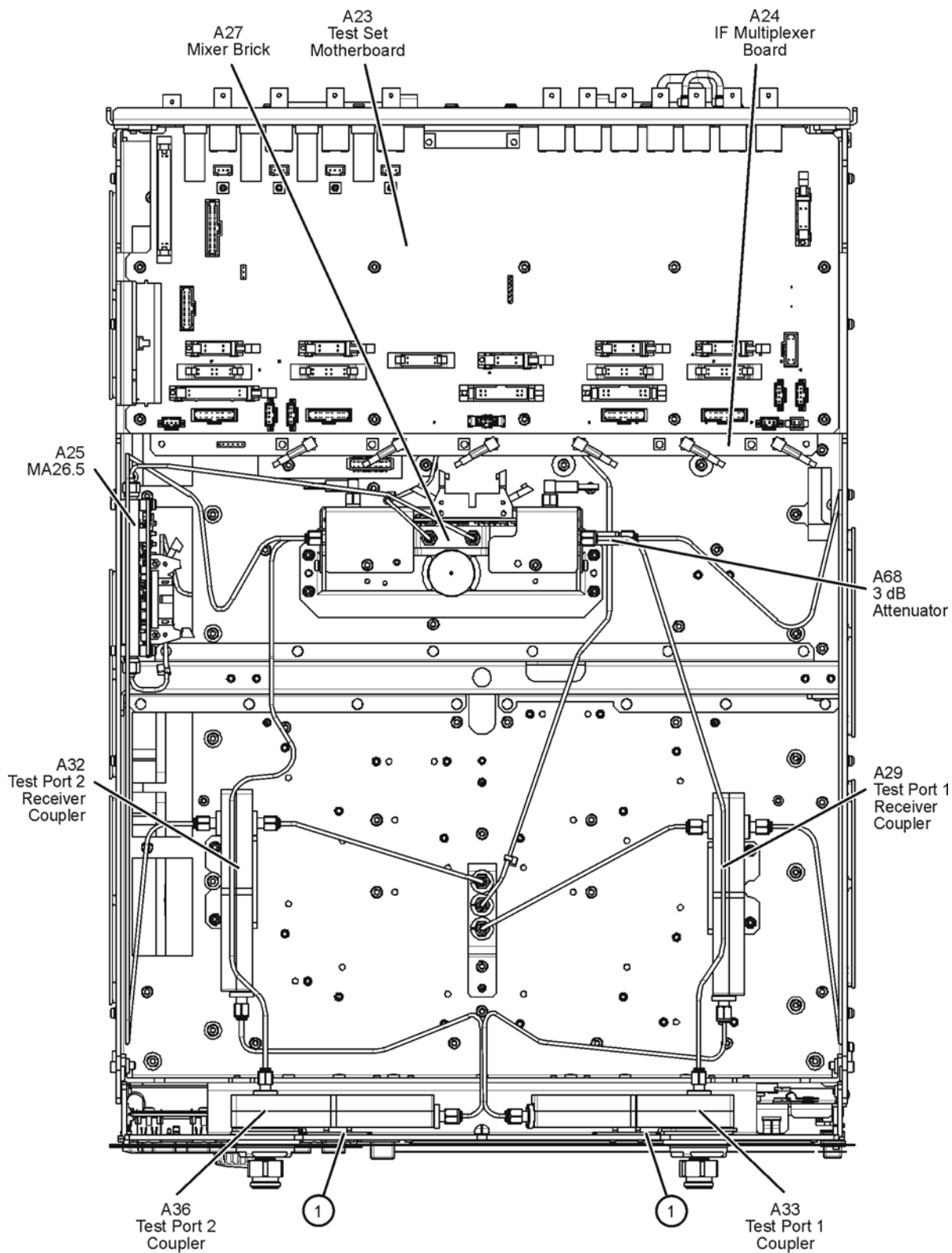

(Some parts removed for clarity.)

N5225_001_604

Bottom RF Cables, Standard 2-Port Configuration, Option 200

Reference Designator	Type ^a	Part Number	Qty	Description
W12	SR	N5245-20109	1	A29 port 1 receiver coupler to W11
W18	SR	N5245-20111	1	A32 port 2 receiver coupler to W17
W111	SR	N5224-20012	1	A29 port 1 receiver coupler to A33 port 1 coupler
W107	SR	N5224-20005	1	A29 port 1 receiver coupler to mixer brick (R1) via A68 3 dB pad
W115	SR	N5224-20010	1	A33 port 1 coupler to mixer brick (A)
W114	SR	N5224-20011	1	A32 port 2 receiver coupler to A36 port 2 coupler
W118	SR	N5224-20009	1	A36 port 2 coupler to mixer brick (B)
W110	SR	N5224-20006	1	A32 port 2 receiver coupler to mixer brick (R2)
W51	SR	Refer to “Top Cables, All Cables—All Options” on page 6-20.		
W56	SR	N5245-20103	1	W55 to rear-panel EXT TSET DRIVE RF OUT (J6)
W57	SR	N5245-20012	1	A27 mixer brick to rear panel EXT TSET DRIVE LO OUT (J5)
W61	F	N5242-60017	1	A27 mixer brick (A) to A24 IF multiplexer (P1)
W62	F	N5242-60025	1	A27 mixer brick (R1) to A24 IF multiplexer (P601)
W63	F	N5242-60026	1	A27 mixer brick (R2) to A24 IF multiplexer (P801)
W64	F	N5242-60018	1	A27 mixer brick (B) to A24 IF multiplexer (P201)
W69-73	F	Refer to “Top Cables, All Cables—All Options” on page 6-20.		
W80	SR	N5245-20048	1	A25 HMA26.5 to A27 mixer brick

a. SR = semirigid coaxial cable; F = flexible coaxial cable

Figure 6-9 Bottom RF Cables, Standard 2-Port Configuration, Option 200

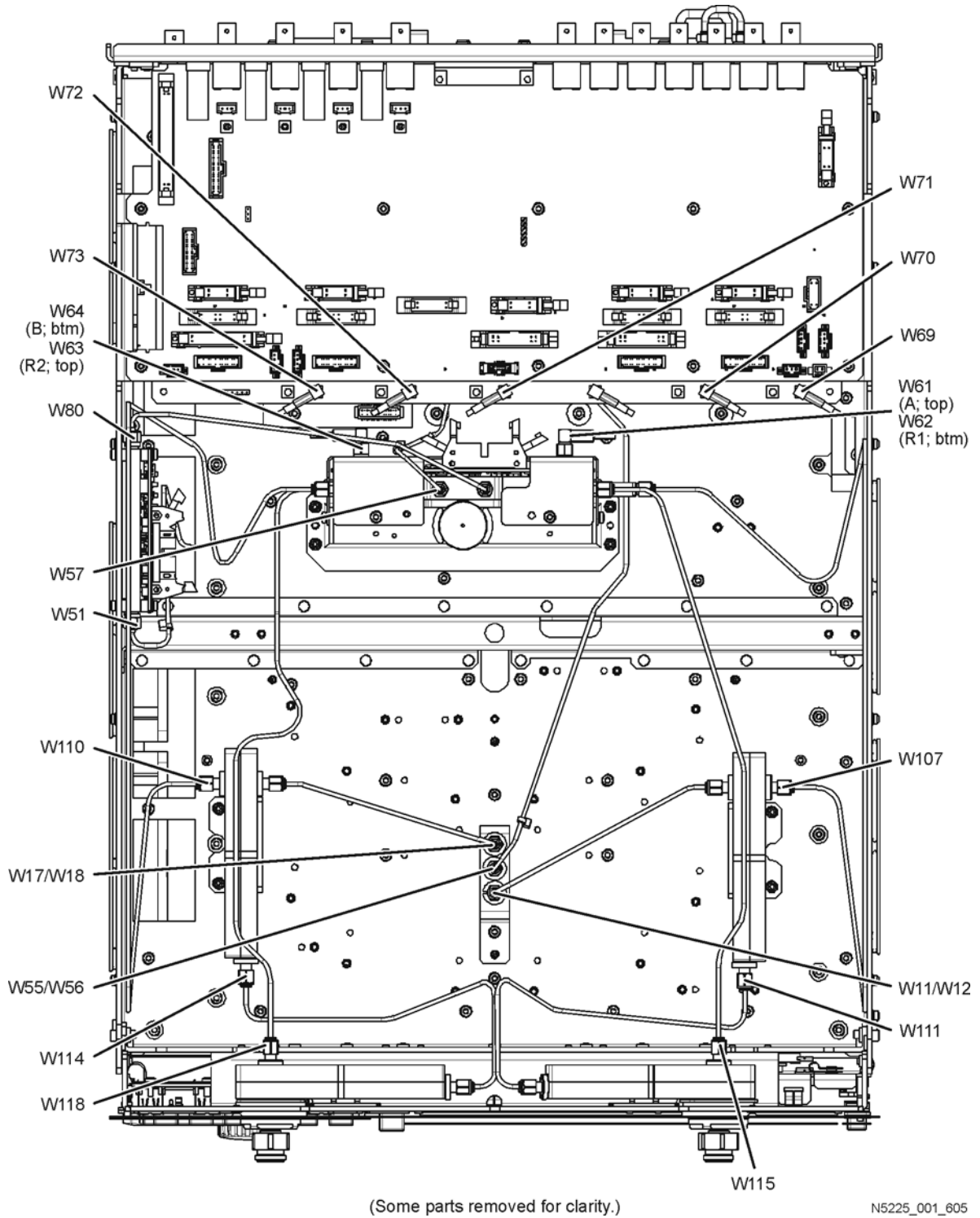

Bottom Ribbon Cables and Wire Harnesses, Standard 2-Port Configuration, Option 200

Reference Designator	Type^a	Part Number	Description
①	10R	N5242-60005	Rear-panel PWR I/O to A23 test set motherboard J301
②	3W	N5225-60001	A23 test set motherboard J221 to ports 1/3 LED board J1
③	20R	N5247-60015 Was N5245-60008	A23 test set motherboard J551 to A27 mixer brick (1) J52
④	3W	N5225-60001	A23 test set motherboard J222 to ports 2/4 LED board J1
⑤	24R	N5230-60014 Was N5242-60011	A23 test set motherboard J209 to A25 HMA26.5 J1
⑥	100R	N5242-60004	A18 system motherboard J1 to A23 test set motherboard J1 to A24 IF multiplexer board J1
⑦	25R	E4410-60160	A18 system motherboard J13 to A23 test set motherboard J545
⑧	36R	8121-0834	Rear-panel HANDLER I/O to A23 test set motherboard J400

a. nR = n wires in a ribbon (flat) cable; nW = n wires in a wire harness

Figure 6-10 Bottom Ribbon Cables and Wire Harnesses, Standard 2-Port Configuration, Option 200

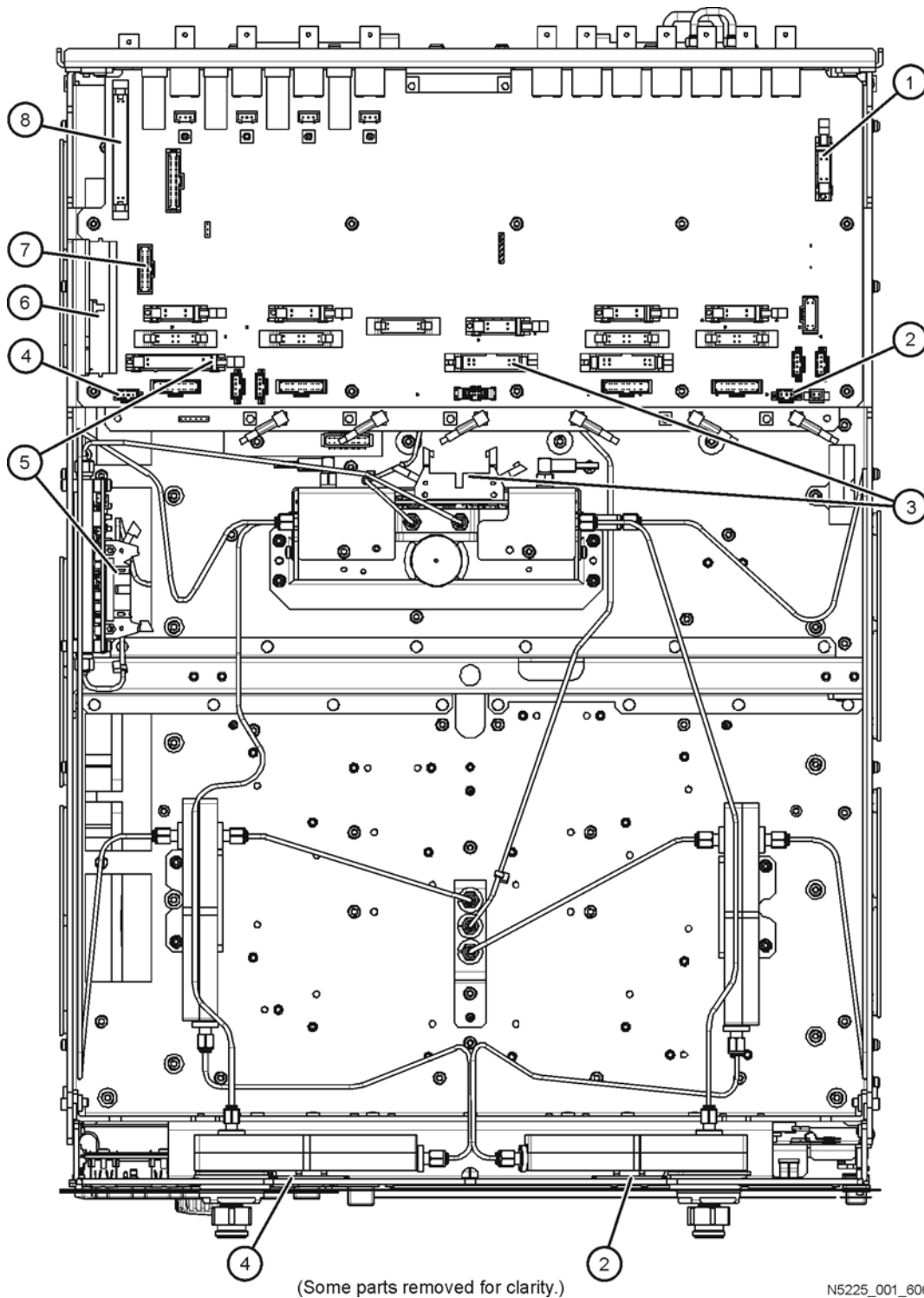

2-Port Configuration, Option 201

Bottom Assemblies, 2-Port, Option 201

Reference Designator	Part Number ^a	Qty	Description
A23	N5245-60157 <i>Was N5247-60001</i>	1	Test set motherboard
A24	N5240-60062	1	IF multiplexer board
A25	5087-7765	1	LO Multiplier/amplifier 26.5 (HMA26.5)
A27	5087-7323 <i>5087-6323</i>	1	Mixer brick
A29 A32	5087-7760	2	Test port 1 receiver coupler Test port 2 receiver coupler
A33 A36	5087-7793	2	Test port 1 coupler Test port 2 coupler
A37	5087-7759	1	Reference mixer switch
①	N5240-60058	2	Front panel LED board

- a. Part numbers in italic typeface are for rebuilt exchange assemblies. Refer to **“Rebuilt-Exchange Assemblies”** on page 6-5.

Figure 6-11 Bottom Assemblies, 2-Port, Option 201

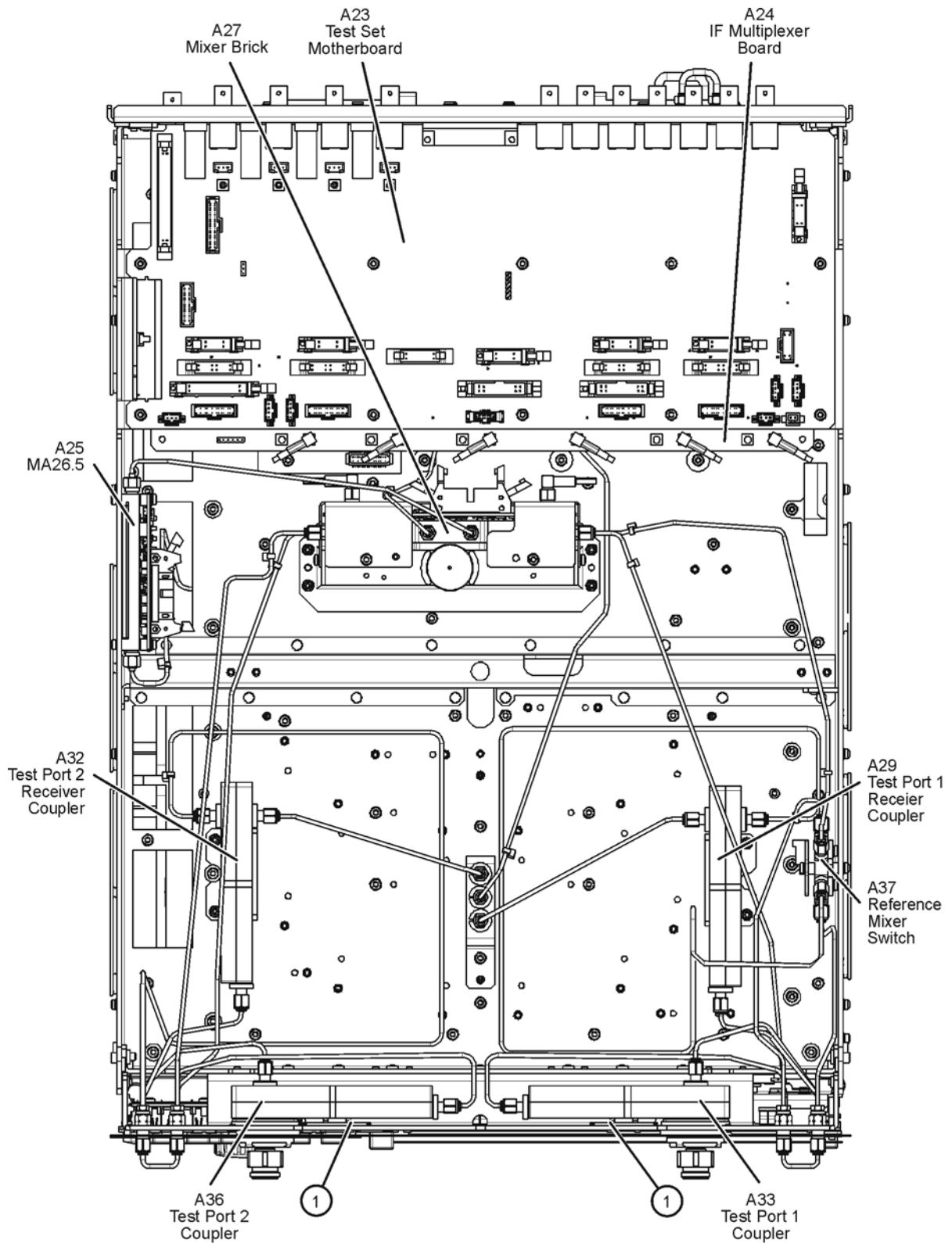

(Some parts removed for clarity.)

N5225_001_607

Bottom RF Cables, 2-Port, Option 201

Reference Designator	Type ^a	Part Number	Qty	Description
W12	SR	N5245-20109	1	A29 port 1 receiver coupler to W11
W18	SR	N5245-20111	1	A32 port 2 receiver coupler to W17
W19	SR	N5245-20039	1	A29 port 1 receiver coupler to front-panel Port 1 SOURCE OUT
W20	SR	N5245-20045	1	Port 1 CPLR THRU to A33 port 1 coupler
W21	SR	N5245-20120	1	A29 port 1 receiver coupler to A37 reference mixer switch
W22	SR	N5245-20025	1	A33 port 1 coupler to front-panel REF 1 CPLR ARM
W31	SR	N5245-20040	1	A32 port 2 receiver coupler to front-panel Port 2 SOURCE OUT
W32	SR	N5245-20106	1	Port 2 CPLR THRU to A36 port 2 coupler
W34	SR	N5245-20024	1	A36 port 2 coupler to front-panel REF 2 CPLR ARM
W35	SR	N5245-20121	1	A32 port 2 receiver coupler to front-panel REF 2 SOURCE OUT
W36	SR	N5245-20155 Was N5245-20104	6	Front panel jumper
W37	SR	N5245-20041	1	Port 1 RCVR A IN to A27 mixer brick (A)
W40	SR	N5245-20042	1	Front panel port 2 RCVR B IN to A27 mixer brick (B)
W41	SR	N5245-20006	1	A37 reference mixer switch to front-panel REF 1 SOURCE OUT
W42	SR	N5245-20007	1	REF 1 RCVR R1 IN to A37 reference mixer switch
W43	SR	N5245-20009	1	A37 reference mixer switch to A27 mixer brick (R1)
W46	SR	N5245-20011	1	REF 2 RCVR R2 IN to A27 mixer brick (R2)
W51	SR	Refer to “Top Cables, All Cables—All Options” on page 6-20.		
W56	SR	N5245-20103	1	W55 to rear-panel EXT TSET DRIVE RF OUT (J6)
W57	SR	N5245-20012	1	A27 mixer brick to rear panel EXT TSET DRIVE LO OUT (J5)
W61	F	N5242-60017	1	A27 mixer brick (A) to A24 IF multiplexer (P1)
W62	F	N5242-60025	1	A27 mixer brick (R1) to A24 IF multiplexer (P601)
W63	F	N5242-60026	1	A27 mixer brick (R2) to A24 IF multiplexer (P801)
W64	F	N5242-60018	1	A27 mixer brick (B) to A24 IF multiplexer (P201)
W69-73	F	Refer to “Top Cables, All Cables—All Options” on page 6-20.		
W80	SR	N5245-20048	1	A25 HMA26.5 to A27 mixer brick

a. SR = semirigid coaxial cable; F = flexible coaxial cable

Figure 6-12 Bottom RF Cables, 2-Port, Option 201

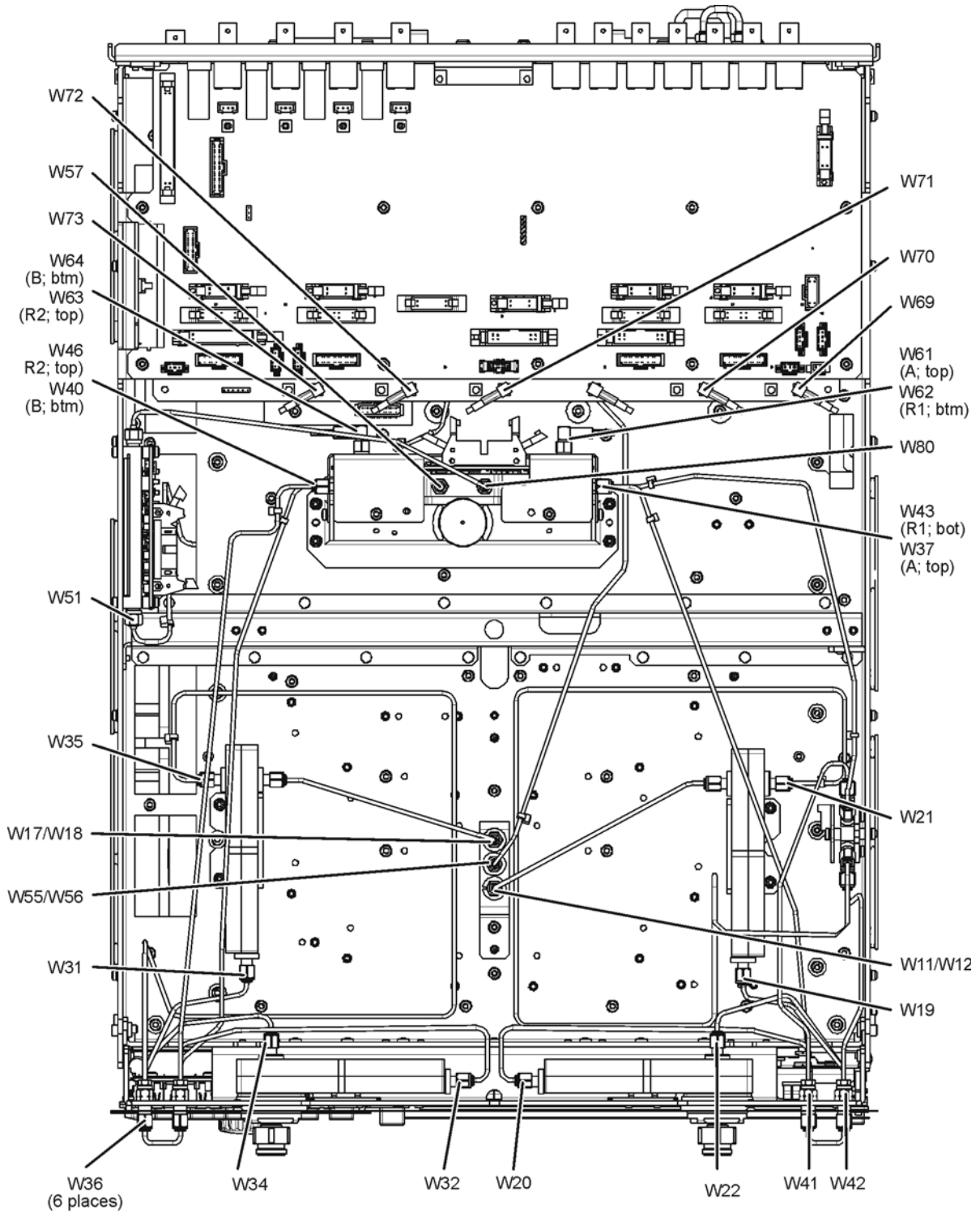

(Some parts removed for clarity.)

N5225_001_608

Bottom Ribbon Cables and Wire Harnesses, 2-Port, Option 201

Reference Designator	Type^a	Part Number	Description
①	10R	N5242-60005	Rear-panel PWR I/O to A23 test set motherboard J301
②	2W	8121-0966	A23 test set motherboard J554 to A37 reference mixer switch
③	3W	N5225-60001	A23 test set motherboard J221 to ports 1/3 LED board J1
④	20R	N5247-60015 Was N5245-60008	A23 test set motherboard J551 to A27 mixer brick (1) J52
⑤	3W	N5225-60001	A23 test set motherboard J222 to ports 2/4 LED board J1
⑥	24R	N5230-60014 Was N5242-60011	A23 test set motherboard J209 to A25 HMA26.5 J1
⑦	100R	N5242-60004	A18 system motherboard J1 to A23 test set motherboard J1 to A24 IF multiplexer board J1
⑧	25R	E4410-60160	A18 system motherboard J13 to A23 test set motherboard J545
⑨	36R	8121-0834	Rear-panel HANDLER I/O to A23 test set motherboard J400

a. nR = n wires in a ribbon (flat) cable; nW = n wires in a wire harness

Figure 6-13 Bottom Ribbon Cables and Wire Harnesses, 2-Port, Option 201

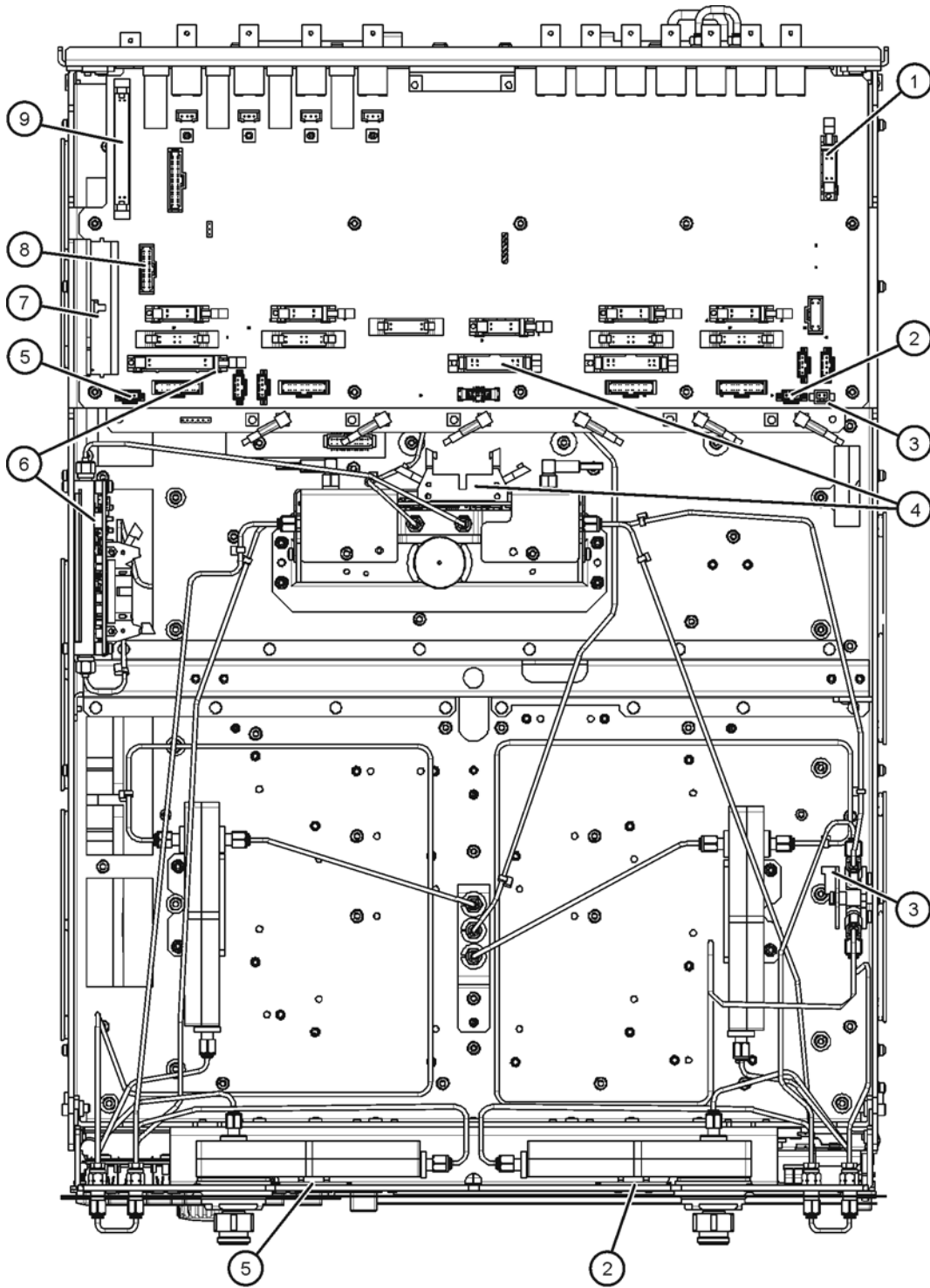

(Some parts removed for clarity.)

N5225_001_609

2-Port Configuration, Option 210

Bottom Assemblies, 2-Port, Option 210

Reference Designator	Part Number ^a	Qty	Description
A23	N5245-60157 <i>Was N5247-60001</i>	1	Test set motherboard
A24	N5240-60062	1	IF multiplexer board
A25	5087-7765	1	LO Multiplier/amplifier 26.5 (HMA26.5)
A27	5087-7323 <i>5087-6323</i>	1	Mixer brick
A29 A32	5087-7760	2	Test port 1 receiver coupler Test port 2 receiver coupler
A33 A36	5087-7793	2	Test port 1 coupler Test port 2 coupler
A64 A67	08490-60040	2	Test port 1 6-dB attenuator Test port 2 6-dB attenuator
①	N5240-60058	2	Front panel LED board
A68	08490-60039	1	3 dB attenuator (pad) connected to mixer brick (R1)

- a. Part numbers in italic typeface are for rebuilt exchange assemblies. Refer to [“Rebuilt-Exchange Assemblies”](#) on [page 6-5](#).

Figure 6-14 Bottom Assemblies, 2-Port, Option 210

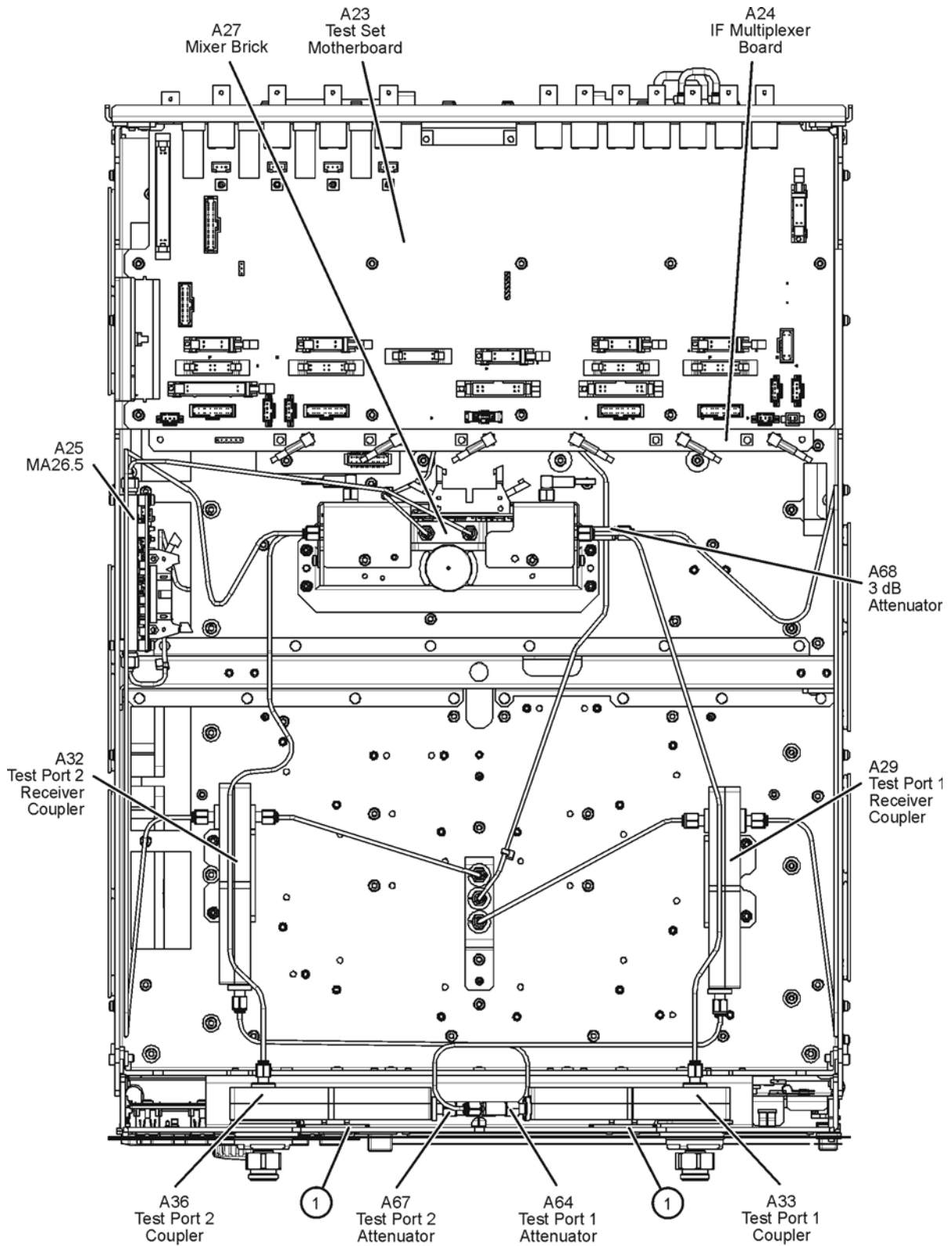

(Some parts removed for clarity.)

N5225_001_610

Bottom RF Cables, 2-Port, Option 210

Reference Designator	Type ^a	Part Number	Qty	Description
W12	SR	N5245-20109	1	A29 port 1 receiver coupler to W11
W18	SR	N5245-20111	1	A32 port 2 receiver coupler to W17
W123	SR	N5224-20008	1	A29 port 1 receiver coupler to A64 6-dB attenuator
W107	SR	N5224-20005	1	A29 port 1 receiver coupler to mixer brick (R1) via A68 3 dB pad
W115	SR	N5224-20010	1	A33 port 1 coupler to mixer brick (A)
W124	SR	N5224-20007	1	A32 port 2 receiver coupler to A67 6-dB attenuator
W118	SR	N5224-20009	1	A36 port 2 coupler to mixer brick (B)
W110	SR	N5224-20006	1	A32 port 2 receiver coupler to mixer brick (R2)
W51	SR	Refer to "Top Cables, All Cables—All Options" on page 6-20.		
W56	SR	N5245-20103	1	W55 to rear-panel EXT TSET DRIVE RF OUT (J6)
W57	SR	N5245-20012	1	A27 mixer brick to rear panel EXT TSET DRIVE LO OUT (J5)
W61	F	N5242-60017	1	A27 mixer brick (A) to A24 IF multiplexer (P1)
W62	F	N5242-60025	1	A27 mixer brick (R1) to A24 IF multiplexer (P601)
W63	F	N5242-60026	1	A27 mixer brick (R2) to A24 IF multiplexer (P801)
W64	F	N5242-60018	1	A27 mixer brick (B) to A24 IF multiplexer (P201)
W69-73	F	Refer to "Top Cables, All Cables—All Options" on page 6-20.		
W80	SR	N5245-20048	1	A25 HMA26.5 to A27 mixer brick

a. SR = semirigid coaxial cable; F = flexible coaxial cable

Figure 6-15 Bottom RF Cables, 2-Port, Option 210

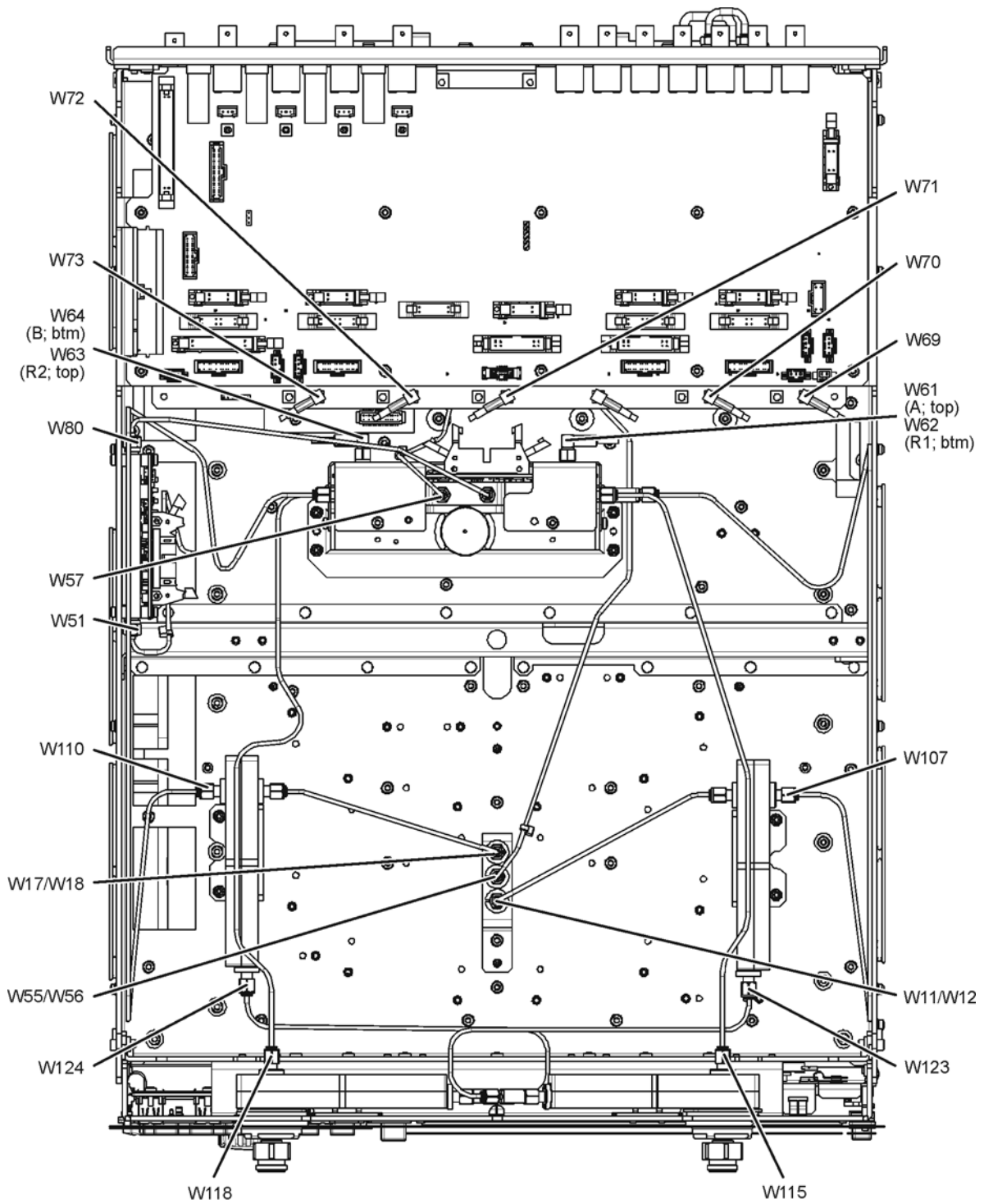

(Some parts removed for clarity.)

N5225_001_611

Bottom Ribbon Cables and Wire Harnesses, 2-Port, Option 210

Reference Designator	Type^a	Part Number	Description
①	10R	N5242-60005	Rear-panel PWR I/O to A23 test set motherboard J301
②	3W	N5225-60001	A23 test set motherboard J221 to ports 1/3 LED board J1
③	20R	N5247-60015 Was N5245-60008	A23 test set motherboard J551 to A27 mixer brick (1) J52
④	3W	N5225-60001	A23 test set motherboard J222 to ports 2/4 LED board J1
⑤	24R	N5230-60014 Was N5242-60011	A23 test set motherboard J209 to A25 HMA26.5 J1
⑥	100R	N5242-60004	A18 system motherboard J1 to A23 test set motherboard J1 to A24 IF multiplexer board J1
⑦	25R	E4410-60160	A18 system motherboard J13 to A23 test set motherboard J545
⑧	36R	8121-0834	Rear-panel HANDLER I/O to A23 test set motherboard J400

a. nR = n wires in a ribbon (flat) cable; nW = n wires in a wire harness

Figure 6-16 Bottom Ribbon Cables and Wire Harnesses, 2-Port, Option 210

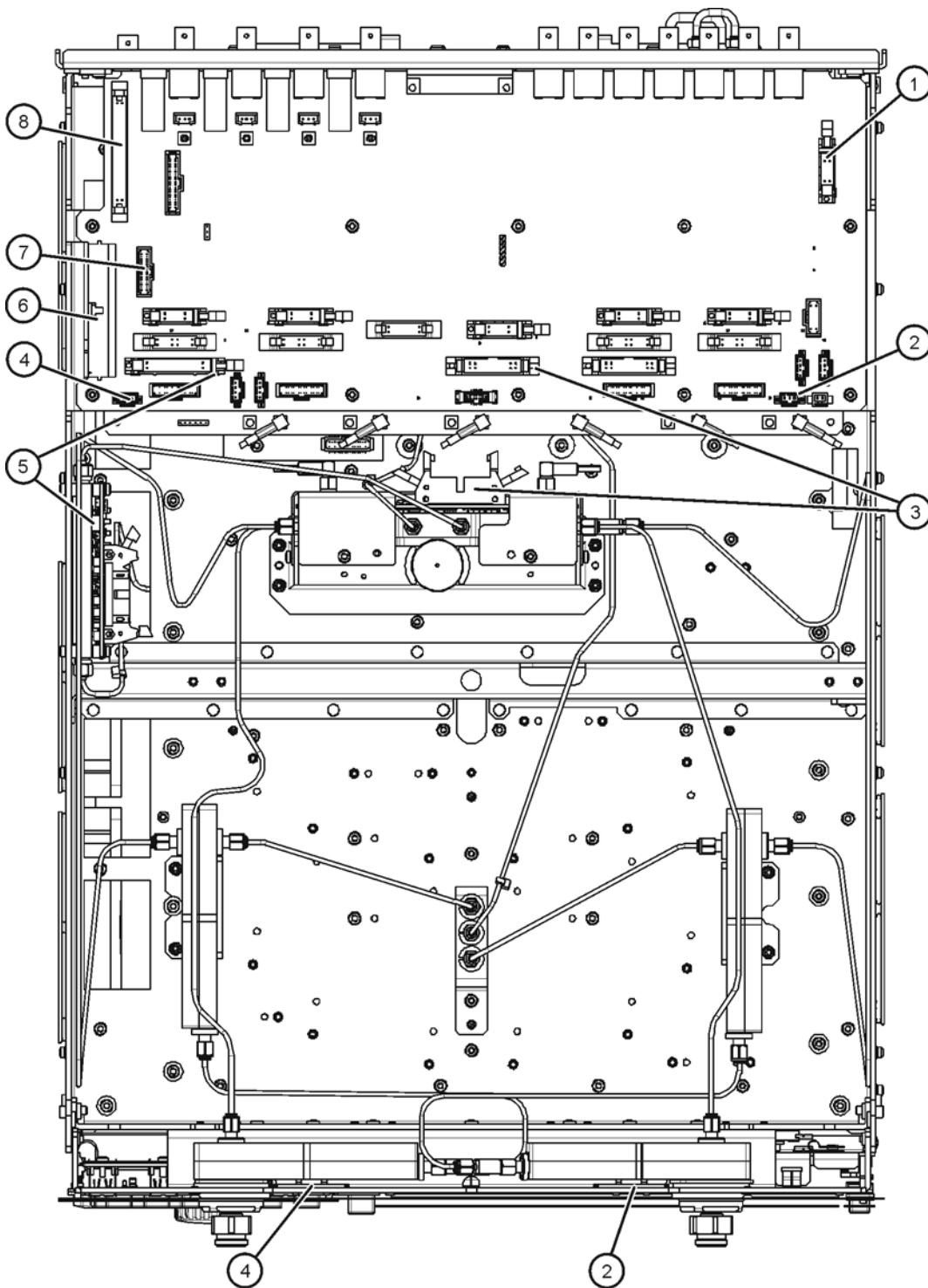

(Some parts removed for clarity.)

N5225_001_612

2-Port Configuration, Option 217

Bottom Assemblies, 2-Port, Option 217

Reference Designator	Part Number ^a	Qty	Description
A23	N5245-60157 <i>Was N5247-60001</i>	1	Test set motherboard
A24	N5240-60062	1	IF multiplexer board
A25	5087-7765	1	LO Multiplier/amplifier 26.5 (HMA26.5)
A27	5087-7323 <i>5087-6323</i>	1	Mixer brick
A29 A32	5087-7760	2	Test port 1 receiver coupler Test port 2 receiver coupler
A33 A36	5087-7793	2	Test port 1 coupler Test port 2 coupler
A37	5087-7759	1	Reference mixer switch
A38 A41	33325-60016	2	Test port 1 source attenuator Test port 2 source attenuator
A46 A49	33325-60017	2	Port 1 receiver attenuator Port 2 receiver attenuator
①	N5240-60058	2	Front panel LED board

- a. Part numbers in italic typeface are for rebuilt exchange assemblies. Refer to [“Rebuilt-Exchange Assemblies”](#) on page 6-5.

Figure 6-17 Bottom Assemblies, 2-Port, Option 217

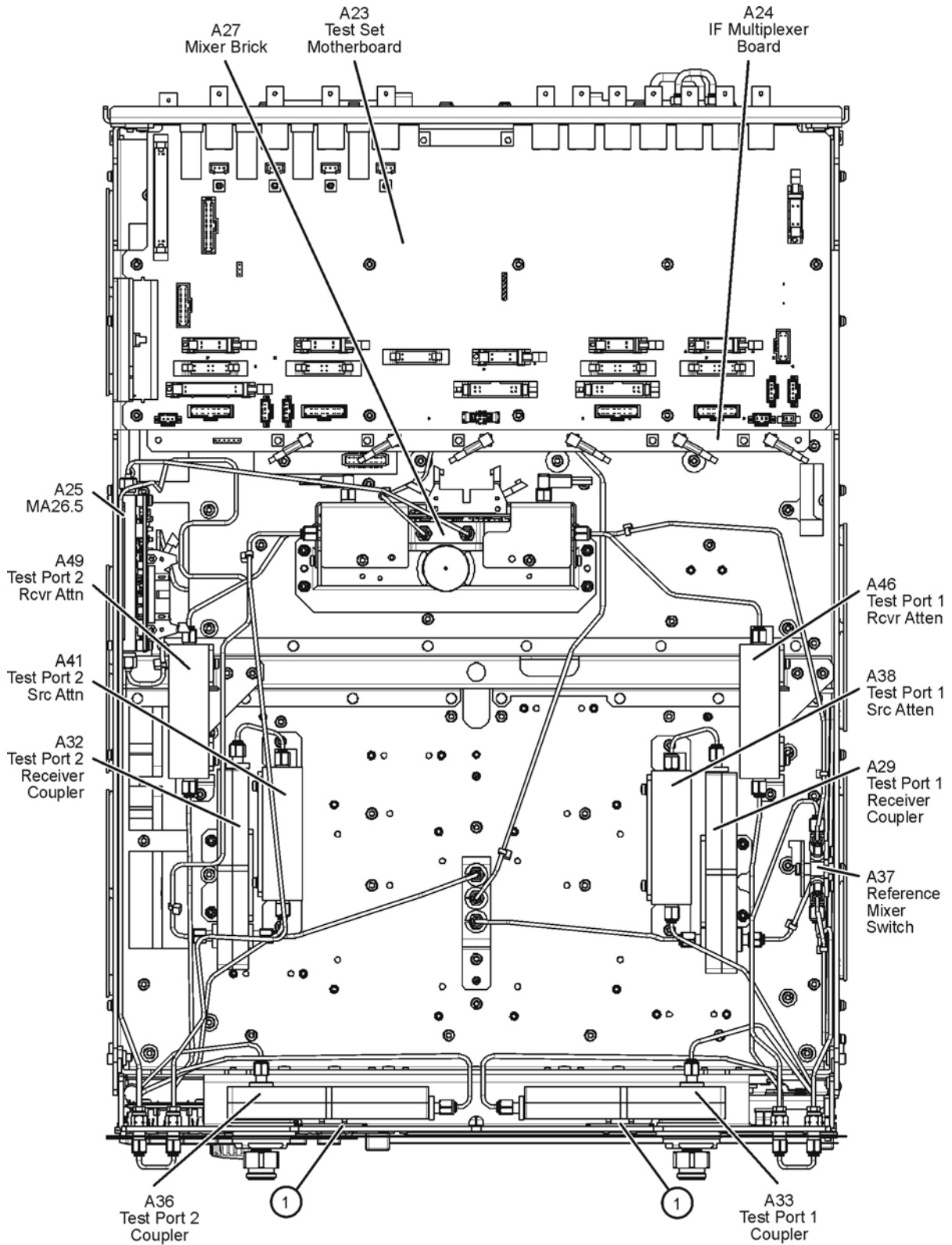

(Some parts removed for clarity.)

N5225_001_613

Bottom RF Cables, 2-Port, Option 217

Reference Designator	Type ^a	Part Number	Qty	Description
W12	SR	N5245-20050	1	A29 port 1 receiver coupler to W11
W18	SR	N5245-20049	1	A32 port 2 receiver coupler to W17
W20	SR	N5245-20045	1	Front panel port 1 CPLR THRU to A33 port 1 coupler
W21	SR	N5245-20118	1	A29 port 1 receiver coupler to A37 reference mixer switch
W22	SR	N5245-20025	1	A33 port 1 coupler to front-panel REF 1 CPLR ARM
W32	SR	N5245-20106	1	Front panel port 2 CPLR THRU to A36 port 2 coupler
W33	SR	N5245-20010	1	A32 port 2 receiver coupler to front-panel REF 2 SOURCE OUT
W34	SR	N5245-20024	1	A36 port 2 coupler to front-panel REF 2 CPLR ARM
W36	SR	N5245-20155 Was N5245-20104	6	Front panel jumper
W41	SR	N5245-20006	1	A37 reference mixer switch to front-panel REF 1 SOURCE OUT
W42	SR	N5245-20007	1	REF 1 RCVR R1 IN to A37 reference mixer switch
W43	SR	N5245-20009	1	A37 reference mixer switch to A27 mixer brick (R1)
W47	SR	N5245-20119	1	A27 mixer brick (R2) to front-panel REF 2 RCVR R2 IN
W51	SR	Refer to "Top Cables, All Cables—All Options" on page 6-20.		
W56	SR	N5245-20103	1	W55 to rear-panel EXT TSET DRIVE RF OUT (J6)
W57	SR	N5245-20012	1	A27 mixer brick to EXT TSET DRIVE LO OUT (J5)
W61	F	N5242-60017	1	A27 mixer brick (A) to A24 IF multiplexer (P1)
W62	F	N5242-60025	1	A27 mixer brick (R1) to A24 IF multiplexer (P601)
W63	F	N5242-60026	1	A27 mixer brick (R2) to A24 IF multiplexer (P801)
W64	F	N5242-60018	1	A27 mixer brick (B) to A24 IF multiplexer (P201)
W69-73	F	Refer to "Top Cables, All Cables—All Options" on page 6-20.		
W80	SR	N5245-20048	1	A25 HMA26.5 to A27 mixer brick
W81	SR	N5245-20029	1	A29 port 1 receiver coupler to A38 port 1 source attenuator
W82	SR	N5245-20077	1	A38 port 1 source attenuator to front-panel Port 1 SOURCE OUT
W93	SR	N5245-20029	1	A32 port 2 receiver coupler to A41 port 2 source attenuator
W94	SR	N5245-20031	1	A41 port 2 source attenuator to front-panel Port 2 SOURCE OUT
W97	SR	N5245-20054	1	Front-panel Port 1 RCVR A IN to A46 port 1 receiver attenuator
W98	SR	N5245-20056	1	A46 port 1 receiver attenuator to A27 mixer brick (A)
W103	SR	N5245-20055	1	Port 2 RCVR B IN to A49 port 2 receiver attenuator
W104	SR	N5245-20057	1	A49 port 2 receiver attenuator to A27 mixer brick (B)

a. SR = semirigid coaxial cable; F = flexible coaxial cable

Figure 6-18 Bottom RF Cables, 2-Port, Option 217

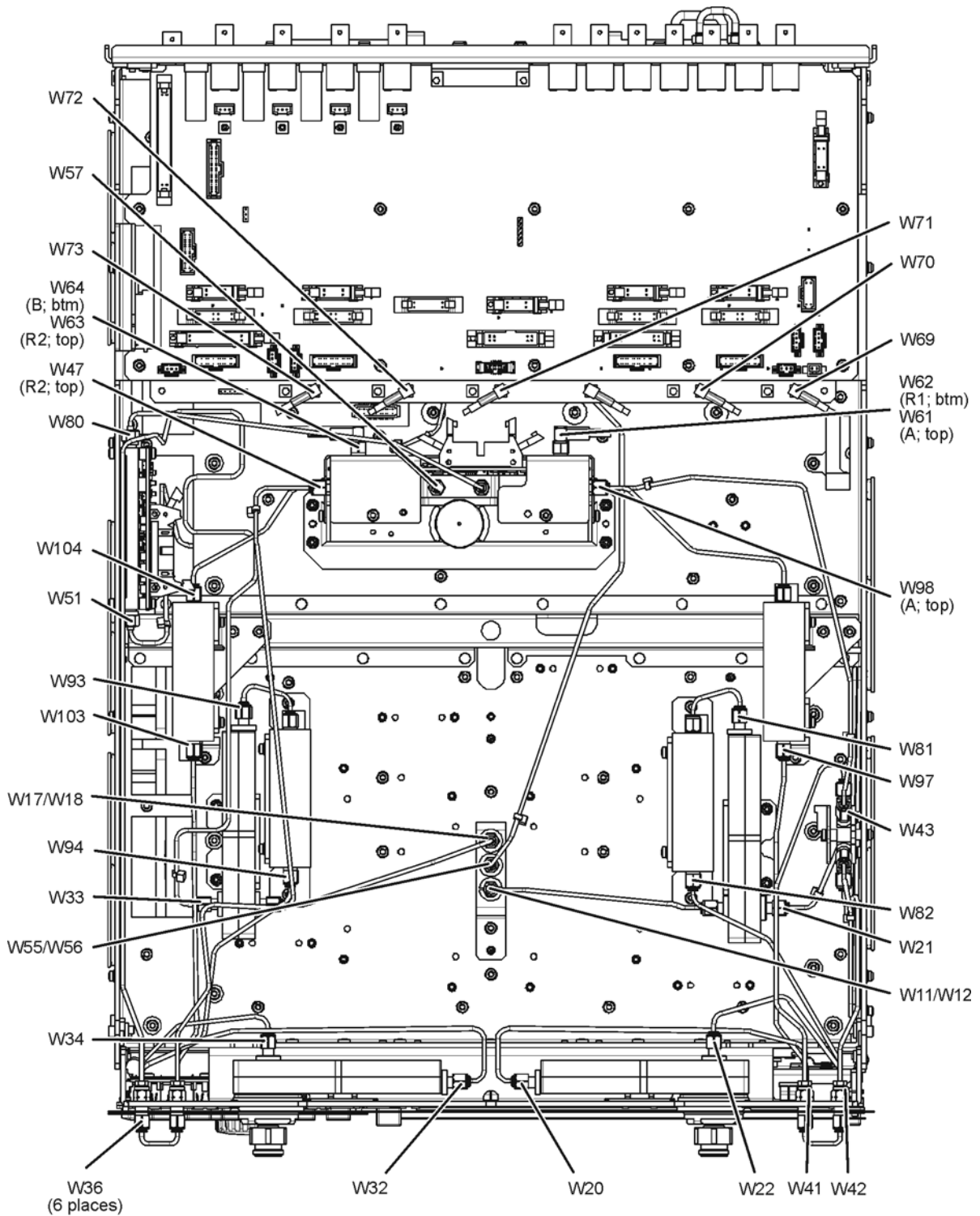

(Some parts removed for clarity.)

N5225_001_614

Bottom Ribbon Cables and Wire Harnesses, 2-Port, Option 217

Reference Designator	Type ^a	Part Number	Description
①	10R	N5242-60005	Rear-panel PWR I/O to A23 test set motherboard J301
②	16R	N5245-60006	A23 test set motherboard J549 to A38 port 1 source attenuator
③	10R	N5245-60026 Was 8121-0982, or N5242-60007	A23 test set motherboard J205 to A46 port 1 receiver attenuator
④	2W	8121-0966	A23 test set motherboard J554 to A37 reference mixer switch
⑤	3W	N5225-60001	A23 test set motherboard J221 to ports 1/3 LED board J1
⑥	20R	N5247-60015 Was N5245-60008	A23 test set motherboard J551 to A27 mixer brick (1) J52
⑦	3W	N5225-60001	A23 test set motherboard J222 to ports 2/4 LED board J1
⑧	16R	N5245-60006	A23 test set motherboard J546 to A41 port 2 source attenuator
⑨	10R	N5245-60026 Was 8121-0982, or N5242-60007	A23 test set motherboard J208 to A49 port 2 receiver attenuator
⑩	24R	N5230-60014 Was N5242-60011	A23 test set motherboard J209 to A25 HMA26.5 J1
⑪	100R	N5242-60004	A18 system motherboard J1 to A23 test set motherboard J1 to A24 IF multiplexer board J1
⑫	25R	E4410-60160	A18 system motherboard J13 to A23 test set motherboard J545
⑬	36R	8121-0834	Rear-panel HANDLER I/O to A23 test set motherboard J400

a. nR = n wires in a ribbon (flat) cable; nW = n wires in a wire harness

Figure 6-19 Bottom Ribbon Cables and Wire Harnesses, 2-Port, Option 217

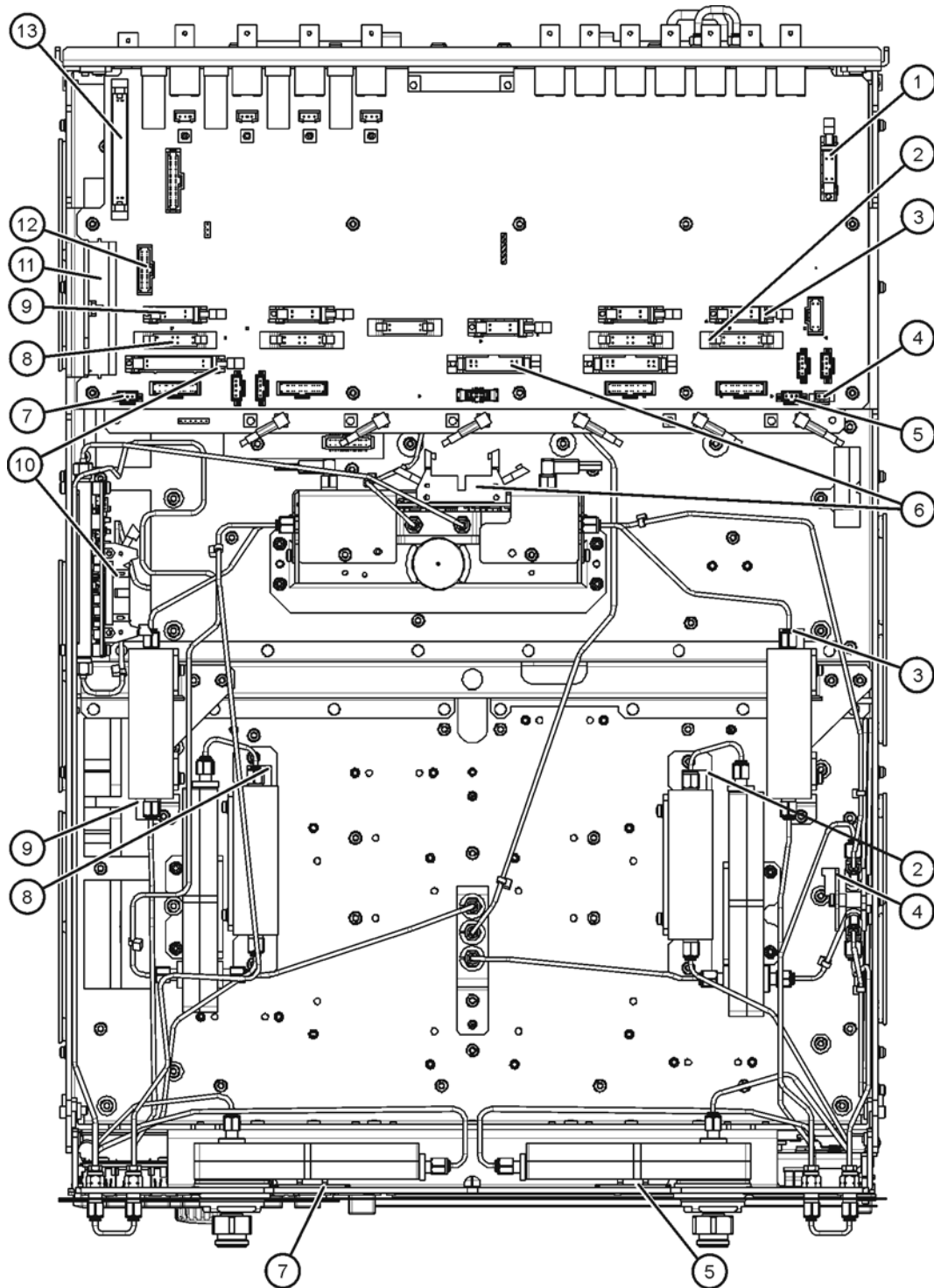

(Some parts removed for clarity.)

N5225_001_615

2-Port Configuration, Option 219

Bottom Assemblies, 2-Port Configuration, Option 219

Reference Designator	Part Number ^a	Qty	Description
A23	N5245-60157 <i>Was N5247-60001</i>	1	Test set motherboard
A24	N5240-60062	1	IF multiplexer board
A25	5087-7765	1	LO Multiplier/amplifier 26.5 (HMA26.5)
A27	5087-7323 <i>5087-6323</i>	1	Mixer brick
A29 A32	5087-7760	2	Test port 1 receiver coupler Test port 2 receiver coupler
A33 A36	5087-7793	2	Test port 1 coupler Test port 2 coupler
A37	5087-7759	1	Reference mixer switch
A38 A41	33325-60016	2	Test port 1 source attenuator Test port 2 source attenuator
A42 A45	5087-7789	2	Test port 1 bias tee (includes wire harness) Test port 2 bias tee (includes wire harness)
A46 A49	33325-60017	2	Port 1 receiver attenuator Port 2 receiver attenuator
①	N5240-60058	2	Front panel LED board

- a. Part numbers in italic typeface are for rebuilt exchange assemblies. Refer to [“Rebuilt-Exchange Assemblies” on page 6-5.](#)

Figure 6-20 Bottom Assemblies, 2-Port, Option 219

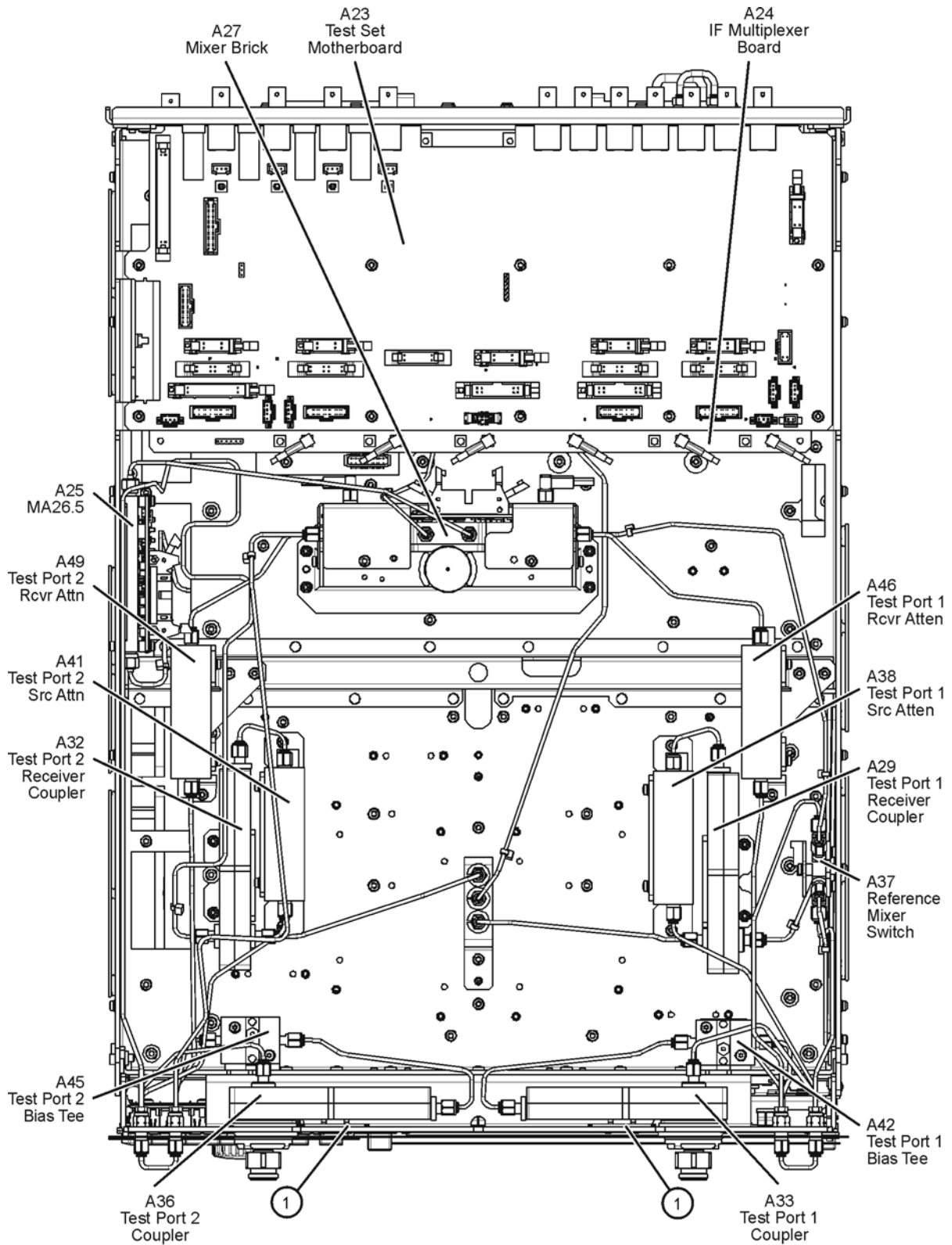

(Some parts removed for clarity.)

N5225_001_616

Bottom RF Cables, 2-Port, Option 219

Reference Designator	Type ^a	Part Number	Qty	Description
W12	SR	N5245-20050	1	A29 port 1 receiver coupler to W11
W18	SR	N5245-20049	1	A32 port 2 receiver coupler to W17
W21	SR	N5245-20118	1	A29 port 1 receiver coupler to A37 reference mixer switch
W22	SR	N5245-20025	1	A33 port 1 coupler to front-panel REF 1 CPLR ARM
W33	SR	N5245-20010	1	A32 port 2 receiver coupler to front-panel REF 2 SOURCE OUT
W34	SR	N5245-20024	1	A36 port 2 coupler to front-panel REF 2 CPLR ARM
W36	SR	N5245-20155 Was N5245-20104	6	Front panel jumper
W41	SR	N5245-20006	1	A37 reference mixer switch to front-panel REF 1 SOURCE OUT
W42	SR	N5245-20007	1	REF 1 RCVR R1 IN to A37 reference mixer switch
W43	SR	N5245-20009	1	A37 reference mixer switch to A27 mixer brick (R1)
W47	SR	N5245-20119	1	A27 mixer brick (R2) to front-panel REF 2 RCVR R2 IN
W51	SR	Refer to "Top Cables, All Cables—All Options" on page 6-20.		
W56	SR	N5245-20103	1	W55 to rear-panel EXT TSET DRIVE RF OUT (J6)
W57	SR	N5245-20012	1	A27 mixer brick to EXT TSET DRIVE LO OUT (J5)
W61	F	N5242-60017	1	A27 mixer brick (A) to A24 IF multiplexer (P1)
W62	F	N5242-60025	1	A27 mixer brick (R1) to A24 IF multiplexer (P601)
W63	F	N5242-60026	1	A27 mixer brick (R2) to A24 IF multiplexer (P801)
W64	F	N5242-60018	1	A27 mixer brick (B) to A24 IF multiplexer (P201)
W69-73	F	Refer to "Top Cables, All Cables—All Options" on page 6-20.		
W80	SR	N5245-20048	1	A25 HMA26.5 to A27 mixer brick
W81	SR	N5245-20029	1	A29 port 1 receiver coupler to A38 port 1 source attenuator
W82	SR	N5245-20077	1	A38 port 1 source attenuator to front-panel Port 1 SOURCE OUT
W83	SR	N5245-20076	1	Front-panel Port 1 CPLR THRU to A42 port 1 bias tee
W84	SR	N5245-20046	1	A33 port 1 coupler to A42 port 1 bias tee
W93	SR	N5245-20029	1	A32 port 2 receiver coupler to A41 port 2 source attenuator
W94	SR	N5245-20031	1	A41 port 2 source attenuator to front-panel Port 2 SOURCE OUT
W95	SR	N5245-20030	1	Front-panel Port 2 CPLR THRU to A45 port 2 bias tee
W96	SR	N5245-20047	1	A36 port 2 coupler to A45 port 2 bias tee
W97	SR	N5245-20054	1	Front-panel Port 1 RCVR A IN to A46 port 1 receiver attenuator
W98	SR	N5245-20056	1	A46 port 1 receiver attenuator to A27 mixer brick (A)
W103	SR	N5245-20055	1	Port 2 RCVR B IN to A49 port 2 receiver attenuator
W104	SR	N5245-20057	1	A49 port 2 receiver attenuator to A27 mixer brick (B)

a. SR = semirigid coaxial cable; F = flexible coaxial cable

Figure 6-21 Bottom RF Cables, 2-Port, Option 219

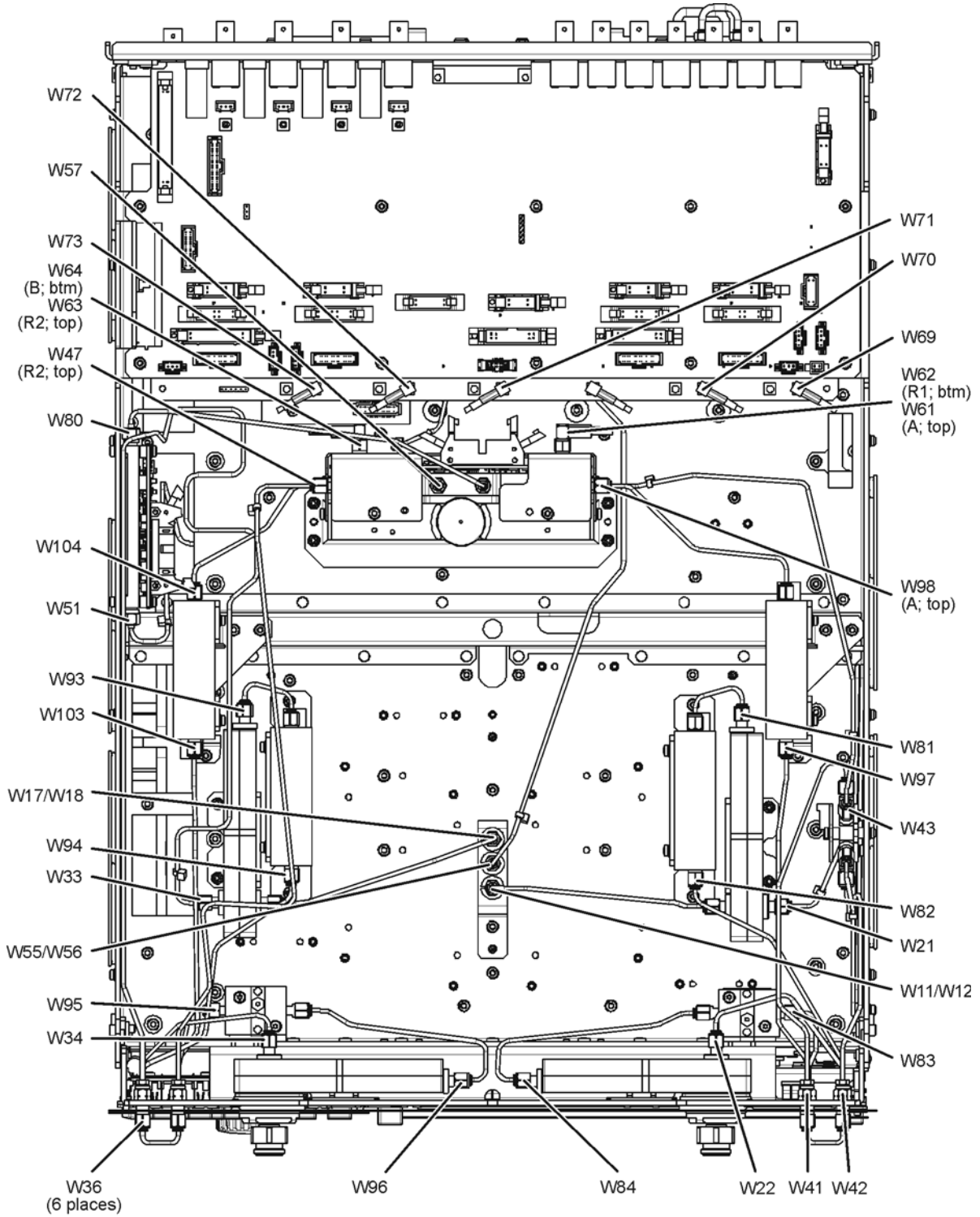

(Some parts removed for clarity.)

N5225_001_617

Bottom Ribbon Cables and Wire Harnesses, 2-Port, Option 219

Reference Designator	Type ^a	Part Number	Description
①	10R	N5242-60005	Rear-panel PWR I/O to A23 test set motherboard J301
②	16R	N5245-60006	A23 test set motherboard J549 to A38 port 1 source attenuator
③	10R	N5245-60026 Was 8121-0982, or N5242-60007	A23 test set motherboard J205 to A46 port 1 receiver attenuator
④	2W	8121-0966	A23 test set motherboard J554 to A37 reference mixer switch
⑤	3W	N5225-60001	A23 test set motherboard J221 to ports 1/3 LED board J1
⑥	20R	N5247-60015 Was N5245-60008	A23 test set motherboard J551 to A27 mixer brick (1) J52
⑦	2W	P/O bias tee	A23 test set motherboard J541 to A42 port 1 bias tee
⑧	3W	N5225-60001	A23 test set motherboard J222 to ports 2/4 LED board J1
⑨	2W	P/O bias tee	A23 test set motherboard J542 to A45 port 2 bias tee
⑩	16R	N5245-60006	A23 test set motherboard J546 to A41 port 2 source attenuator
⑪	10R	N5245-60026 Was 8121-0982, or N5242-60007	A23 test set motherboard J208 to A49 port 2 receiver attenuator
⑫	24R	N5230-60014 Was N5242-60011	A23 test set motherboard J209 to A25 HMA26.5 J1
⑬	100R	N5242-60004	A18 system motherboard J1 to A23 test set motherboard J1 to A24 IF multiplexer board J1
⑭	25R	E4410-60160	A18 system motherboard J13 to A23 test set motherboard J545
⑮	36R	8121-0834	Rear-panel HANDLER I/O to A23 test set motherboard J400

a. nR = n wires in a ribbon (flat) cable; nW = n wires in a wire harness

Figure 6-22 Bottom Ribbon Cables and Wire Harnesses, 2-Port, Option 219

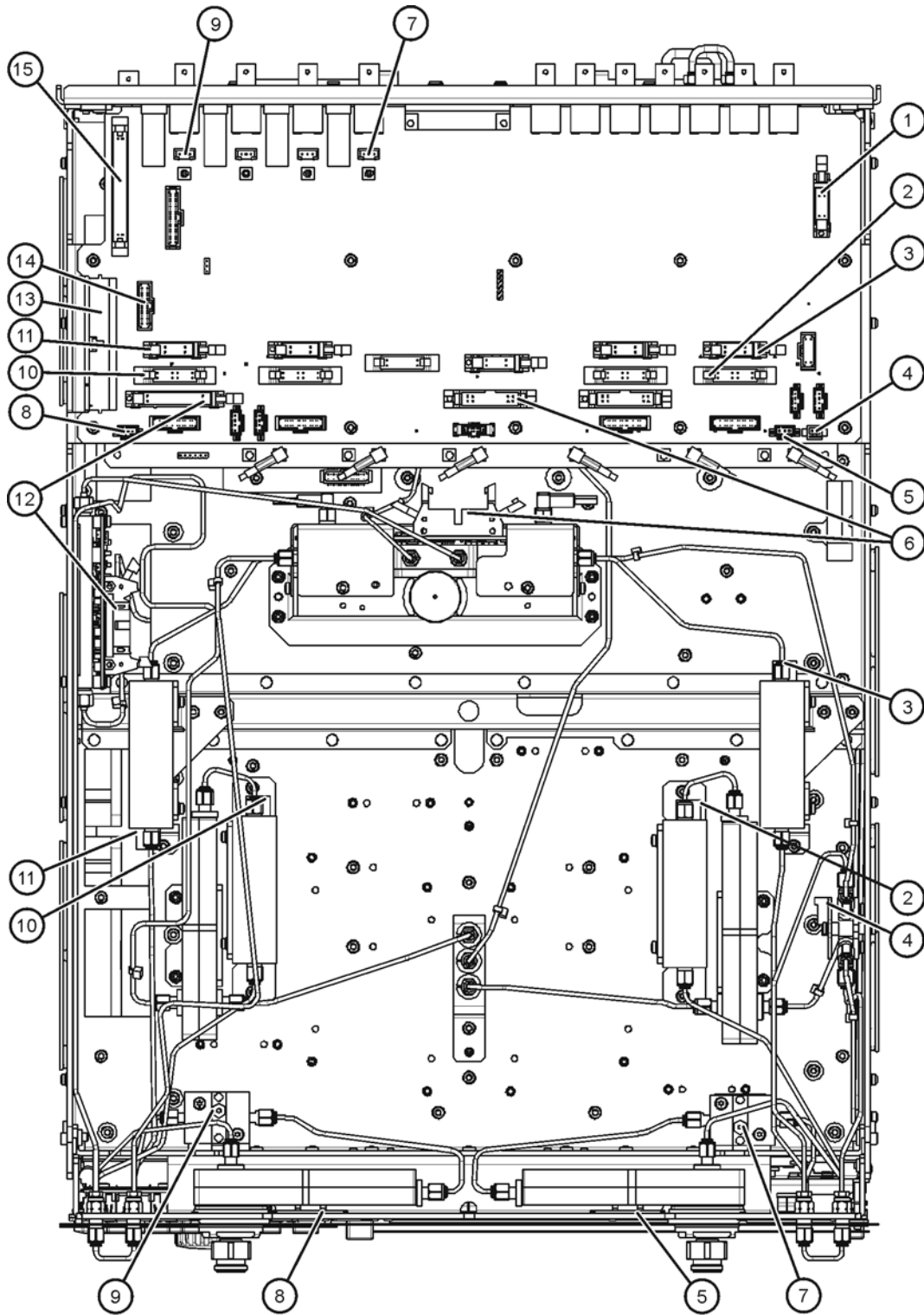

(Some parts removed for clarity.)

N5225_001_618

4-Port Configuration, Option 400

Bottom Assemblies, Standard 4-Port Configuration, Option 400

Reference Designator	Part Number ^a	Qty	Description
A23	N5245-60157 <i>Was N5247-60001</i>	1	Test set motherboard
A24	N5240-60062	1	IF multiplexer board
A25	5087-7765	1	LO Multiplier/amplifier 26.5 (HMA26.5)
A26	5067-4086	1	Splitter
A27 A28	5087-7323 <i>5087-6323</i>	2	Mixer brick
A29 A30 A31 A32	5087-7760	4	Test port 1 receiver coupler Test port 3 receiver coupler Test port 4 receiver coupler Test port 2 receiver coupler
A33 A34 A35 A36	5087-7793	4	Test port 1 coupler Test port 3 coupler Test port 4 coupler Test port 2 coupler
①	N5240-60058	2	Front panel LED board
A68 A69	08490-60039	2	3 dB attenuator (pad) connected to mixer brick (R1) and (R4)

a. Part numbers in italic typeface are for rebuilt exchange assemblies. Refer to [“Rebuilt-Exchange Assemblies” on page 6-5.](#)

Figure 6-23 Bottom Assemblies, Standard 4-Port Configuration, Option 400

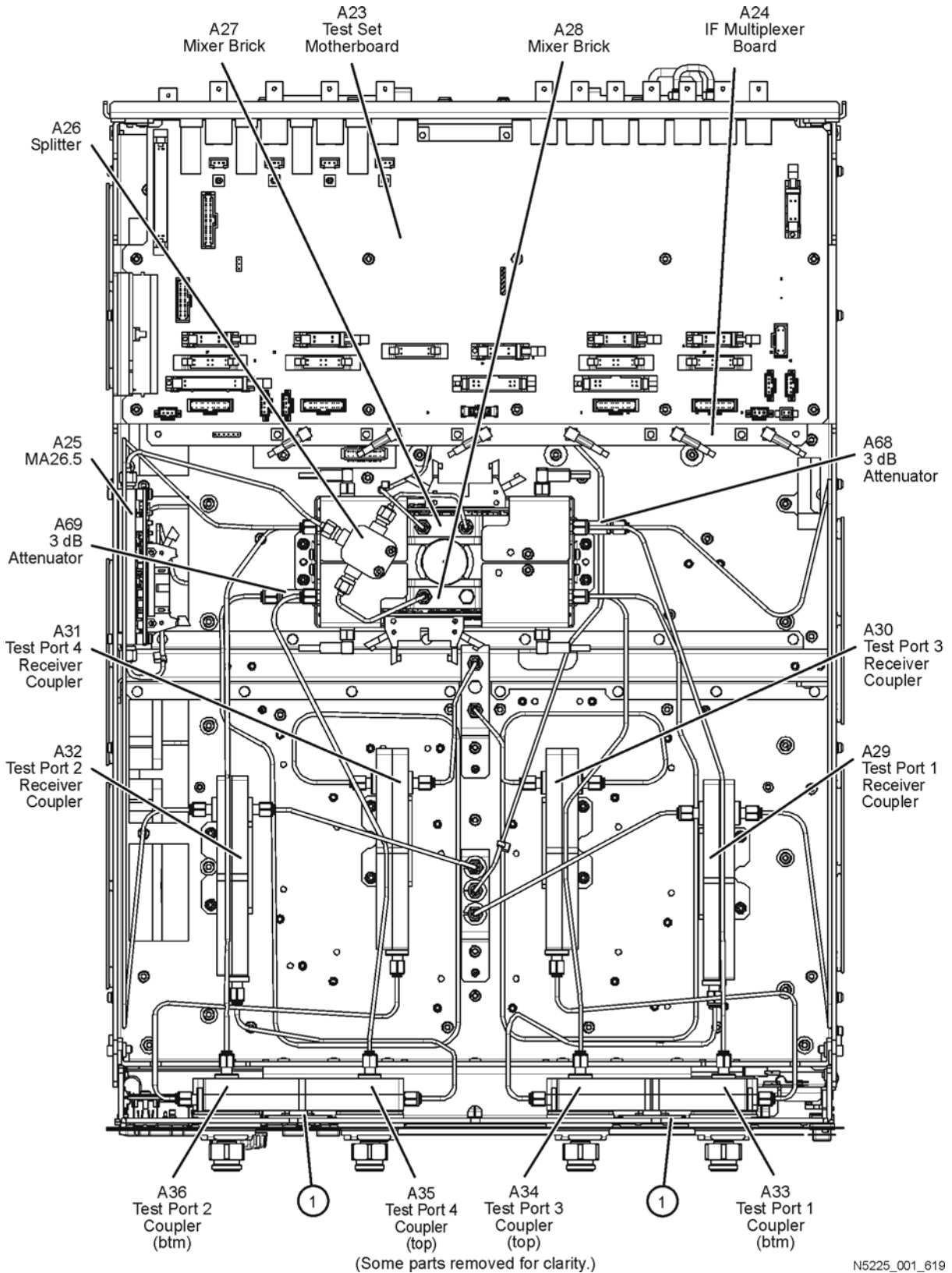

N5225_001_619

Bottom RF Cables, Standard 4-Port Configuration, Option 400

Reference Designator	Type ^a	Part Number	Qty	Description
W12	SR	N5245-20109	1	A29 port 1 receiver coupler to W11
W14	SR	N5245-20043	1	A30 port 3 receiver coupler to W13
W16	SR	N5245-20044	1	A31 port 4 receiver coupler to W15
W18	SR	N5245-20111	1	A32 port 2 receiver coupler to W17
W111	SR	N5224-20013	1	A29 port 1 receiver coupler to A33 port 1 coupler
W107	SR	N5224-20005	1	A29 port 1 receiver coupler to A27 mixer brick (R1)/A68 3 dB pad
W115	SR	N5224-20022	1	A33 port 1 coupler to A27 mixer brick (A)
W112	SR	N5224-20015	1	A30 port 3 receiver coupler to A34 port 3 coupler
W108	SR	N5224-20024	1	A30 port 3 receiver coupler to A28 mixer brick (R3)
W116	SR	N5224-20023	1	A34 port 3 coupler to A28 mixer brick (C)
W113	SR	N5224-20016	1	A31 port 4 receiver coupler to A35 port 4 coupler
W109	SR	N5224-20027	1	A31 port 4 receiver coupler to A28 mixer brick (R4)/A69 3 dB pad
W117	SR	N5224-20026	1	A35 port 4 coupler to A28 mixer brick (D)
W114	SR	N5224-20014	1	A32 port 2 receiver coupler to A36 port 2 coupler
W118	SR	N5224-20025	1	A36 port 2 coupler to A27 mixer brick (B)
W110	SR	N5224-20028	1	A32 port 2 receiver coupler to A27 mixer brick (R2)
W51	SR	Refer to "Top Cables, All Cables—All Options" on page 6-20.		
W52	SR	N5245-20013	1	A25 HMA26.5 to A26 splitter
W53	SR	N5245-20023	1	A26 splitter to A27 mixer brick
W54	SR	N5245-20022	1	A26 splitter to A28 mixer brick
W56	SR	N5245-20103	1	W55 to rear-panel EXT TSET DRIVE RF OUT (J6)
W57	SR	N5245-20012	1	A27 mixer brick to EXT TSET DRIVE LO OUT (J5)
W61	F	N5242-60017	1	A27 mixer brick (A) to A24 IF multiplexer (P1)
W62	F	N5242-60021	1	A27 mixer brick (R1) to A24 IF multiplexer (P411)
W63	F	N5242-60022	1	A27 mixer brick (R2) to A24 IF multiplexer (P412)
W64	F	N5242-60018	1	A27 mixer brick (B) to A24 IF multiplexer (P201)
W65	F	N5242-60024	1	A28 mixer brick (D) to A24 IF multiplexer (P801)
W66	F	N5242-60019	1	A28 mixer brick (R4) to A24 IF multiplexer (P414)
W67	F	N5242-60020	1	A28 mixer brick (R3) to A24 IF multiplexer (P413)
W68	F	N5242-60023	1	A28 mixer brick (C) to A24 IF multiplexer (P601)
W69-73	F	Refer to "Top Cables, All Cables—All Options" on page 6-20.		
①	-	N5247-20138	1	Dust cap, A28 mixer brick termination

a. SR = semirigid coaxial cable; F = flexible coaxial cable

Figure 6-24 Bottom RF Cables, Standard 4-Port Configuration, Option 400

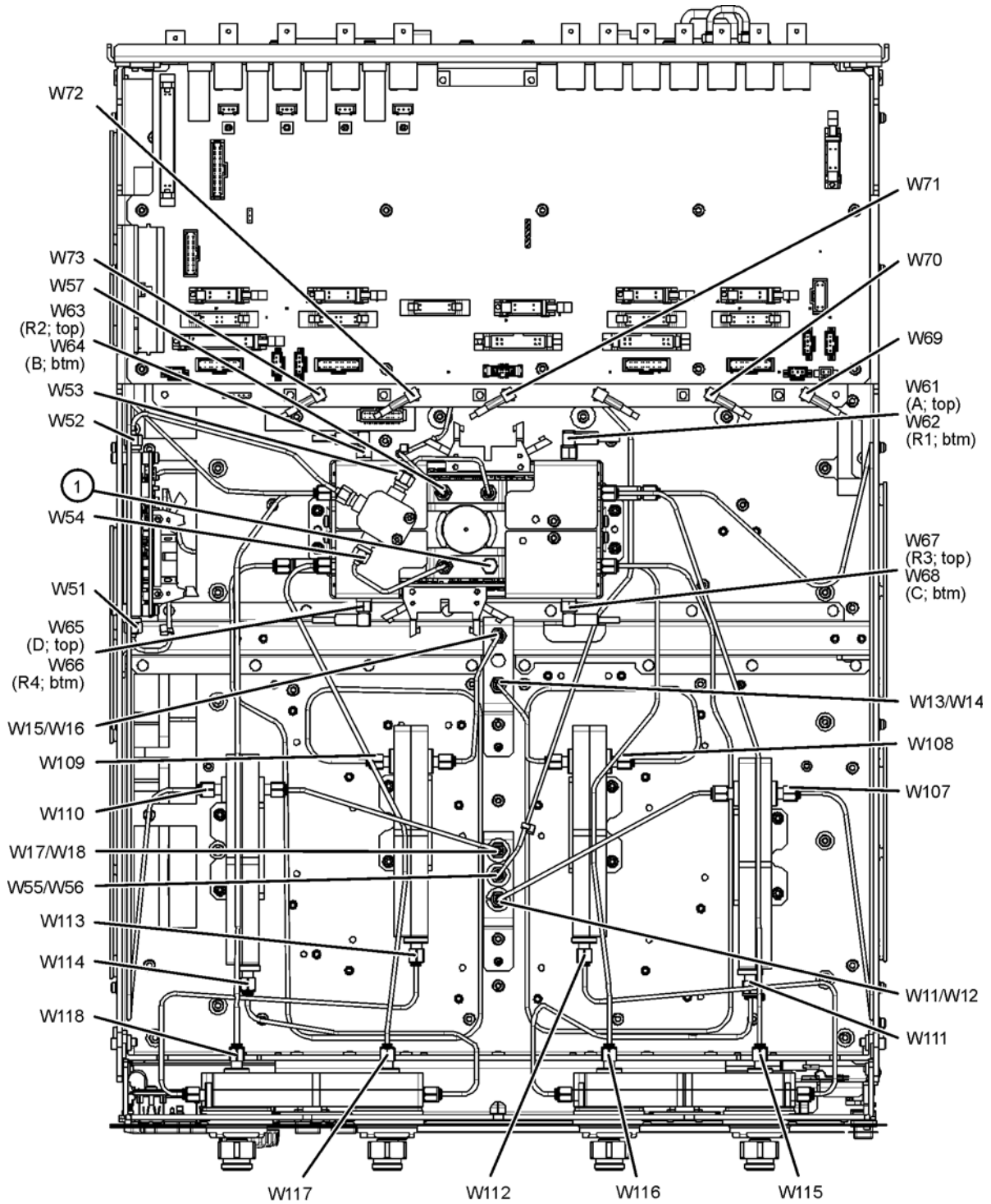

(Some parts removed for clarity.)

N5225_001_620

Bottom Ribbon Cables and Wire Harnesses, Standard 4-Port Configuration, Option 400

Reference Designator	Type^a	Part Number	Description
①	10R	N5242-60005	Rear-panel PWR I/O to A23 test set motherboard J301
②	20R	N5247-60015 Was N5245-60008	A23 test set motherboard J552 to A28 mixer brick (2) J52
③	3W	N5225-60001	A23 test set motherboard J221 to ports 1/3 LED board J1
④	20R	N5247-60015 Was N5245-60008	A23 test set motherboard J551 to A27 mixer brick (1) J52
⑤	3W	N5225-60001	A23 test set motherboard J222 to ports 2/4 LED board J1
⑥	24R	N5230-60014 Was N5242-60011	A23 test set motherboard J209 to A25 HMA26.5 J1
⑦	100R	N5242-60004	A18 system motherboard J1 to A23 test set motherboard J1 to A24 IF multiplexer board J1
⑧	25R	E4410-60160	A18 system motherboard J13 to A23 test set motherboard J545
⑨	36R	8121-0834	Rear-panel HANDLER I/O to A23 test set motherboard J400

a. nR = n wires in a ribbon (flat) cable; nW = n wires in a wire harness

Figure 6-25 Bottom Ribbon Cables and Wire Harnesses, Standard 4-Port Configuration, Option 400

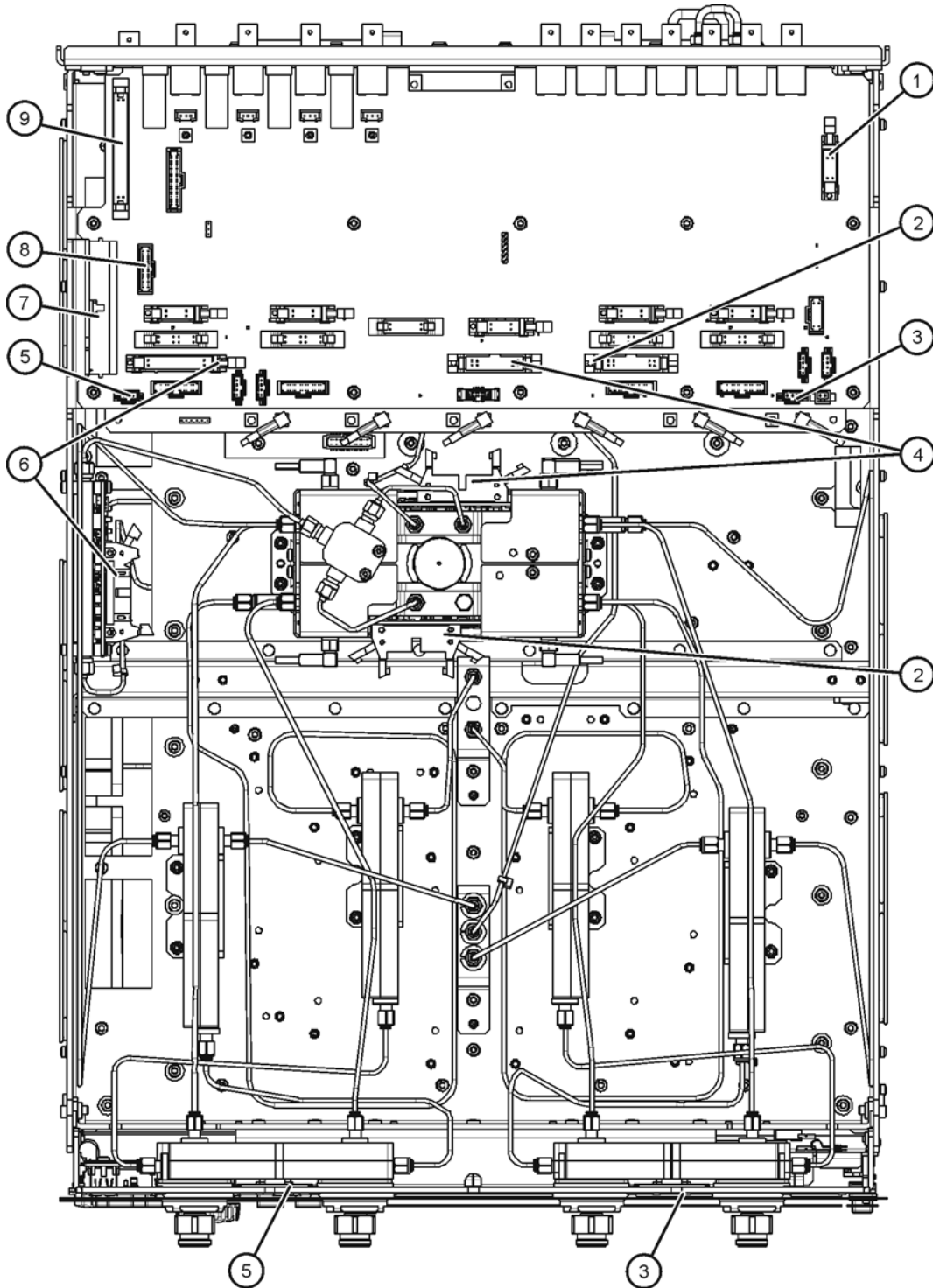

(Some parts removed for clarity.)

N5225_001_621

4-Port Configuration, Option 401

Bottom Assemblies, 4-Port, Option 401

Reference Designator	Part Number ^a	Qty	Description
A23	N5245-60157 <i>Was N5247-60001</i>	1	Test set motherboard
A24	N5240-60062	1	IF multiplexer board
A25	5087-7765	1	LO Multiplier/amplifier 26.5 (HMA26.5)
A26	5067-4086	1	Splitter
A27 A28	5087-7323 <i>5087-6323</i>	2	Mixer brick
A29 A30 A31 A32	5087-7760	4	Test port 1 receiver coupler Test port 3 receiver coupler Test port 4 receiver coupler Test port 2 receiver coupler
A33 A34 A35 A36	5087-7793	4	Test port 1 coupler Test port 3 coupler Test port 4 coupler Test port 2 coupler
A37	5087-7759	1	Reference mixer switch
A69	08490-60039	2	3 dB attenuator (pad) connected to mixer brick (R4)
①	N5240-60058	2	Front panel LED board

a. Part numbers in italic typeface are for rebuilt exchange assemblies. Refer to [“Rebuilt-Exchange Assemblies” on page 6-5.](#)

Figure 6-26 Bottom Assemblies, 4-Port, Option 401

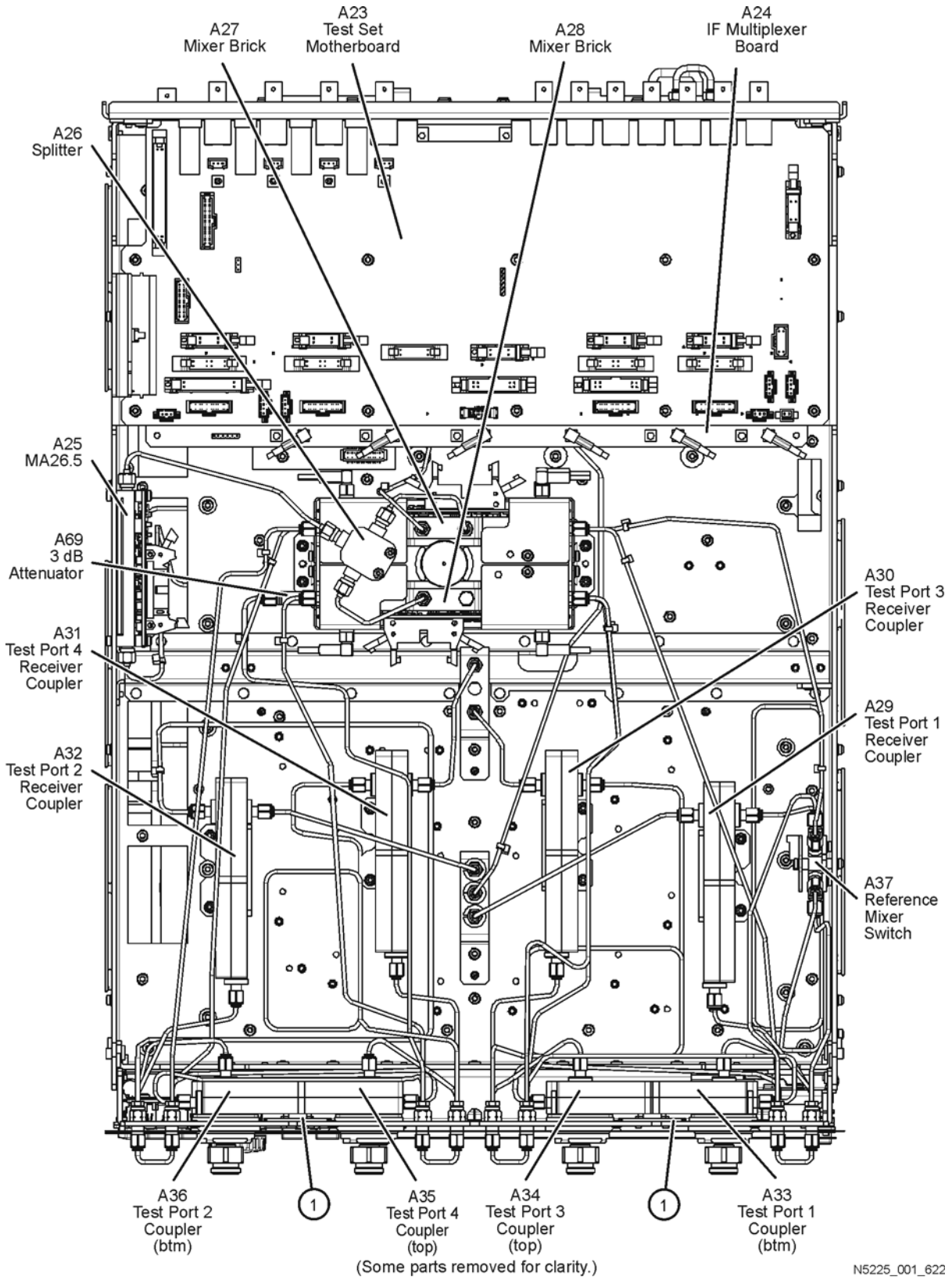

N5225_001_622

Bottom RF Cables, 4-Port, Option 401

Reference Designator	Type	Part Number	Qty	Description
W12	SR	N5245-20109	1	A29 port 1 receiver coupler to W11
W14	SR	N5245-20043	1	A30 port 3 receiver coupler to W13
W16	SR	N5245-20044	1	A31 port 4 receiver coupler to W15
W18	SR	N5245-20111	1	A32 port 2 receiver coupler to W17
W19	SR	N5245-20039	1	A29 port 1 receiver coupler to front-panel Port 1 SOURCE OUT
W20	SR	N5245-20099	1	Port 1 CPLR THRU to A33 port 1 coupler
W21	SR	N5245-20110	1	A29 port 1 receiver coupler to A37 reference mixer switch
W22	SR	N5245-20014	1	A33 port 1 coupler to front-panel Port 1 CPLR ARM
W23	SR	N5245-20051	1	A30 port 3 receiver coupler to front-panel Port 3 SOURCE OUT
W24	SR	N5245-20098	1	Port 3 CPLR THRU to A34 port 3 coupler
W25	SR	N5245-20016	1	A30 port 3 receiver coupler to front-panel REF 3 SOURCE OUT
W26	SR	N5245-20015	1	A34 port 3 coupler to front-panel Port 3 CPLR ARM
W27	SR	N5245-20052	1	A31 port 4 receiver coupler to front-panel Port 4 SOURCE OUT
W28	SR	N5245-20096	1	Port 4 CPLR THRU to A35 port 4 coupler
W29	SR	N5245-20017	1	A31 port 4 receiver coupler to front-panel REF 4 SOURCE OUT
W30	SR	N5245-20018	1	A35 port 4 coupler to front-panel port 4 CPLR ARM
W31	SR	N5245-20040	1	A32 port 2 receiver coupler to front-panel port 2 SOURCE OUT
W32	SR	N5245-20097	1	Port 2 CPLR THRU to A36 port 2 coupler
W33	SR	N5245-20108	1	A32 port 2 receiver coupler to front-panel REF 2 SOURCE OUT
W34	SR	N5245-20019	1	A36 port 2 coupler to front-panel port 2 CPLR ARM
W36	SR	N5245-20155 Was N5245-20104	12	Front panel jumper
W37	SR	N5245-20041	1	Port 1 RCVR A IN to A27 mixer brick (A)
W38	SR	N5245-20037	1	Port 3 RCVR C IN to A28 mixer brick (C)
W39	SR	N5245-20038	1	Port 4 RCVR D IN to A28 mixer brick (D)
W40	SR	N5245-20042	1	Port 2 RCVR B IN to A27 mixer brick (B)
W41	SR	N5245-20006	1	A37 reference mixer switch to front-panel REF 1 SOURCE OUT
W42	SR	N5245-20007	1	REF 1 RCVR R1 IN to A37 reference mixer switch
W43	SR	N5245-20009	1	A37 reference mixer switch to A27 mixer brick (R1)
W44	SR	N5245-20020	1	REF 3 RCVR R3 IN to A28 mixer brick (R3)
W45	SR	N5245-20021	1	REF 4 RCVR R4 IN to A69 3 dB pad on A28 mixer brick (R4)
W46	SR	N5245-20011	1	REF 2 RCVR R2 IN to A27 mixer brick (R2)
W51	SR	Refer to "Top Cables, All Cables—All Options" on page 6-20.		
W52	SR	N5245-20013	1	A25 HMA26.5 to A26 splitter
W53	SR	N5245-20023	1	A26 splitter to A27 mixer brick
W54	SR	N5245-20022	1	A26 splitter to A28 mixer brick
W56	SR	N5245-20103	1	W55 to rear-panel EXT TSET DRIVE RF OUT (J6)
W57	SR	N5245-20012	1	A27 mixer brick to EXT TSET DRIVE LO OUT (J5)
W61	F	N5242-60017	1	A27 mixer brick (A) to A24 IF multiplexer (P1)
W62	F	N5242-60021	1	A27 mixer brick (R1) to A24 IF multiplexer (P411)
W63	F	N5242-60022	1	A27 mixer brick (R2) to A24 IF multiplexer (P412)
W64	F	N5242-60018	1	A27 mixer brick (B) to A24 IF multiplexer (P201)
W65	F	N5242-60024	1	A28 mixer brick (D) to A24 IF multiplexer (P801)
W66	F	N5242-60019	1	A28 mixer brick (R4) to A24 IF multiplexer (P414)
W67	F	N5242-60020	1	A28 mixer brick (R3) to A24 IF multiplexer (P413)
W68	F	N5242-60023	1	A28 mixer brick (C) to A24 IF multiplexer (P601)
W69-73	F	Refer to "Top Cables, All Cables—All Options" on page 6-20.		
①	-	N5247-20138	1	Dust cap, A28 mixer brick termination

Figure 6-27 Bottom RF Cables, 4-Port, Option 401

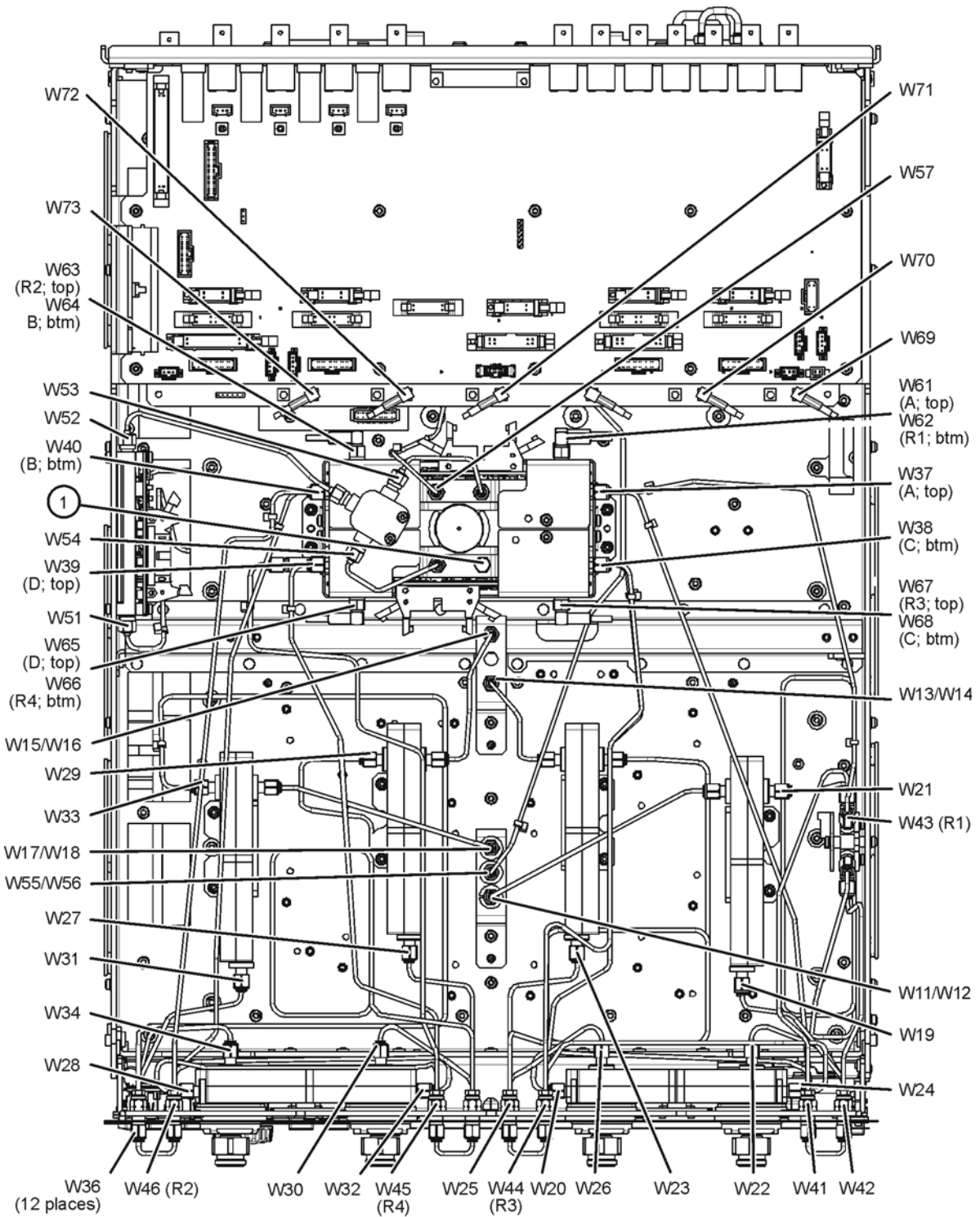

(Some parts removed for clarity.)

N5225_001_623

Bottom Ribbon Cables and Wire Harnesses, 4-Port, Option 401

Reference Designator	Type^a	Part Number	Description
①	10R	N5242-60005	Rear-panel PWR I/O to A23 test set motherboard J301
②	20R	N5247-60015 Was N5245-60008	A23 test set motherboard J552 to A28 mixer brick (2) J52
③	2W	8121-0966	A23 test set motherboard J554 to A37 reference mixer switch
④	3W	N5225-60001	A23 test set motherboard J221 to ports 1/3 LED board J1
⑤	20R	N5247-60015 Was N5245-60008	A23 test set motherboard J551 to A27 mixer brick (1) J52
⑥	3W	N5225-60001	A23 test set motherboard J222 to ports 2/4 LED board J1
⑦	24R	N5230-60014 Was N5242-60011	A23 test set motherboard J209 to A25 HMA26.5 J1
⑧	100R	N5242-60004	A18 system motherboard J1 to A23 test set motherboard J1 to A24 IF multiplexer board J1
⑨	25R	E4410-60160	A18 system motherboard J13 to A23 test set motherboard J545
⑩	36R	8121-0834	Rear-panel HANDLER I/O to A23 test set motherboard J400

a. nR = n wires in a ribbon (flat) cable; nW = n wires in a wire harness

Figure 6-28 Bottom Ribbon Cables and Wire Harnesses, 4-Port, Option 401

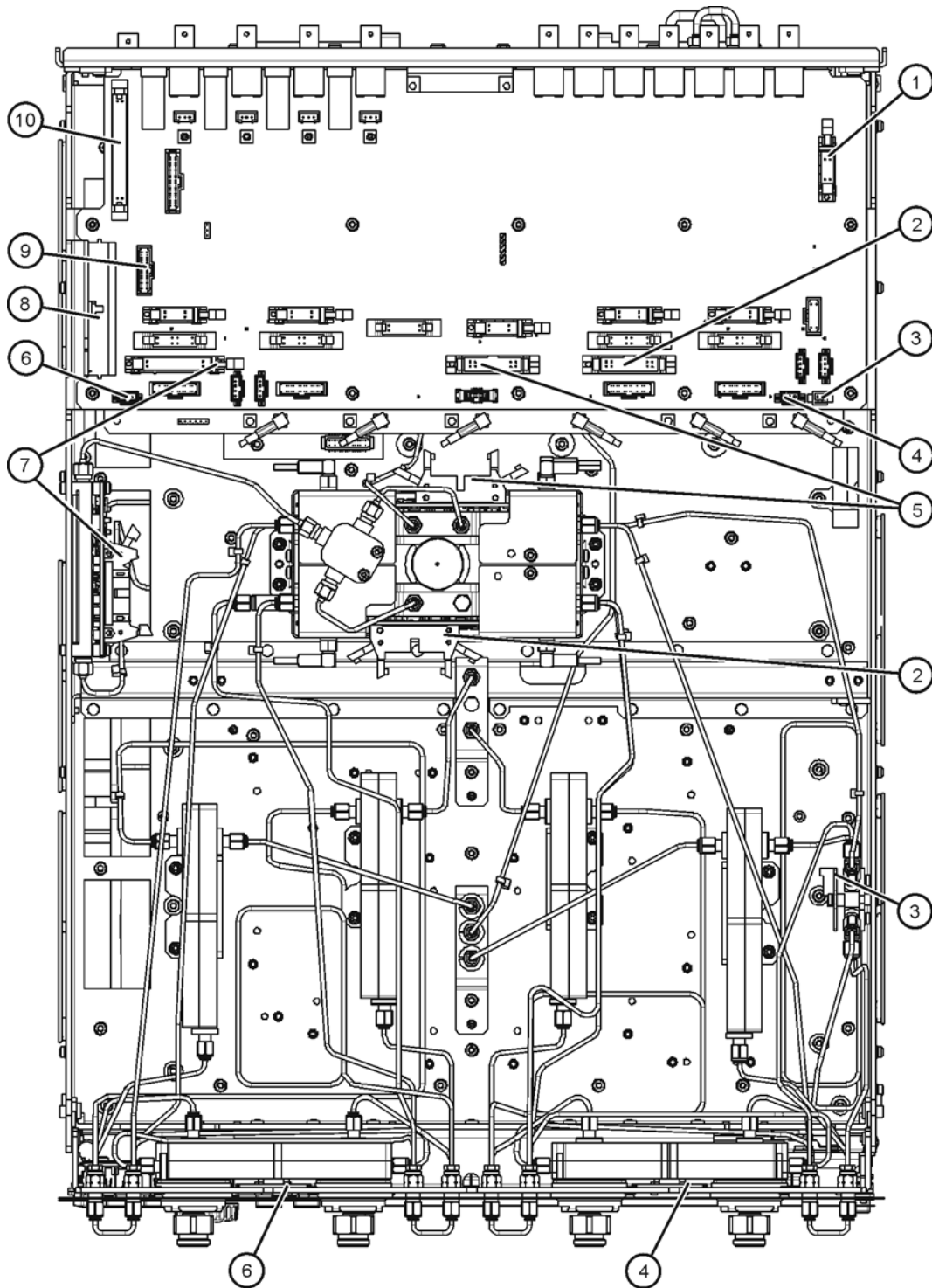

(Some parts removed for clarity.)

N5225_001_624

4-Port Configuration, Option 410

Bottom Assemblies, 4-Port, Option 410

Reference Designator	Part Number ^a	Qty	Description
A23	N5245-60157 <i>Was N5247-60001</i>	1	Test set motherboard
A24	N5240-60062	1	IF multiplexer board
A25	5087-7765	1	LO Multiplier/amplifier 26.5 (HMA26.5)
A26	5067-4086	1	Splitter
A27 A28	5087-7323 <i>5087-6323</i>	2	Mixer brick
A29 A30 A31 A32	5087-7760	4	Test port 1 receiver coupler Test port 3 receiver coupler Test port 4 receiver coupler Test port 2 receiver coupler
A33 A34 A35 A36	5087-7793	4	Test port 1 coupler Test port 3 coupler Test port 4 coupler Test port 2 coupler
A64 A65 A66 A67	08490-60040	4	Test port 1 6-dB attenuator Test port 3 6-dB attenuator Test port 4 6-dB attenuator Test port 2 6-dB attenuator
①	N5240-60058	2	Front panel LED board
A68 A69	08490-60039	2	3 dB attenuator (pad) connected to mixer brick (R1) and (R4)

- a. Part numbers in italic typeface are for rebuilt exchange assemblies. Refer to [“Rebuilt-Exchange Assemblies”](#) on page 6-5.

Figure 6-29 Bottom Assemblies, 4-Port, Option 410

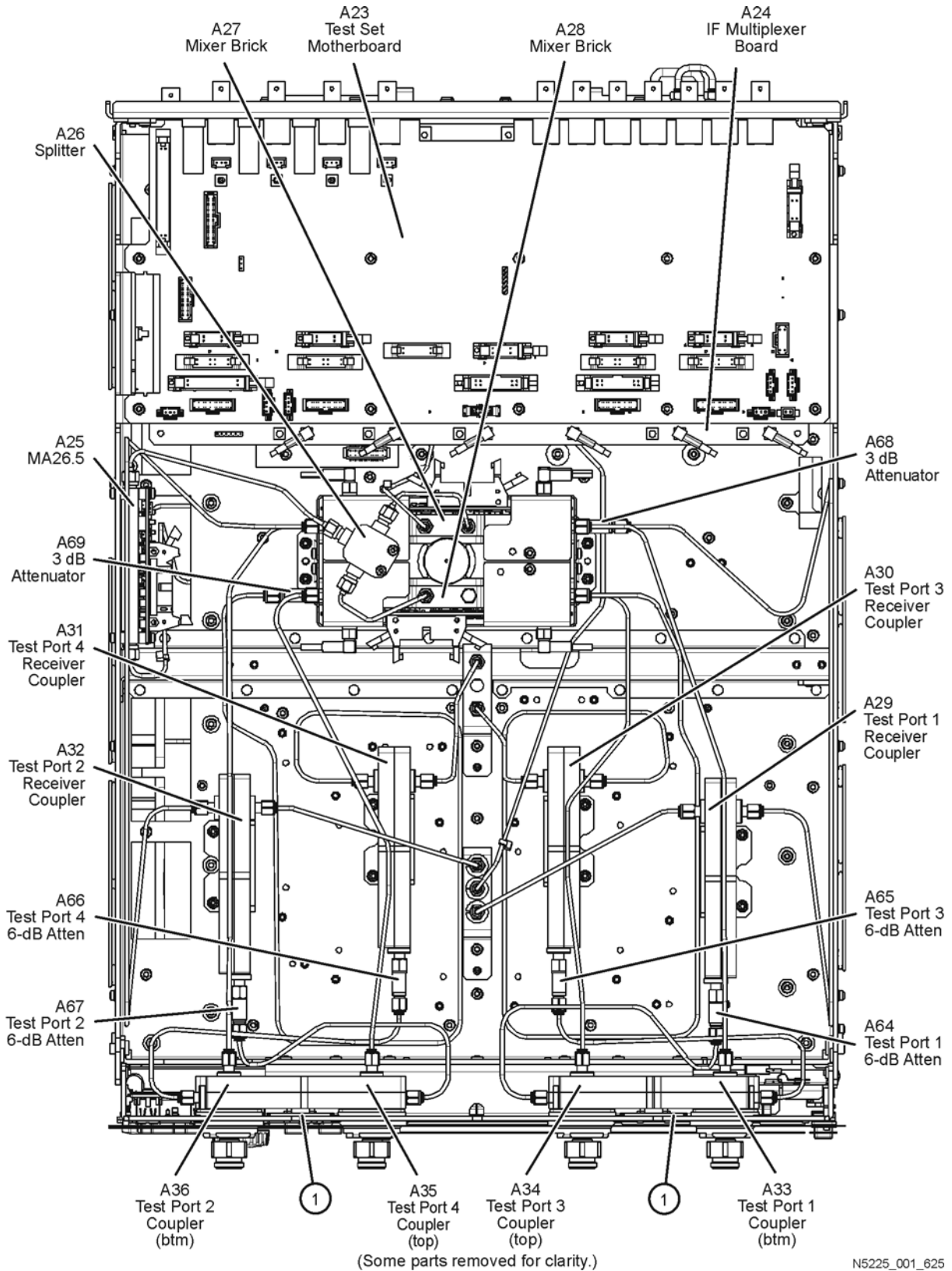

Bottom RF Cables, 4-Port, Option 410

Reference Designator	Type ^a	Part Number	Qty	Description
W12	SR	N5245-20109	1	A29 port 1 receiver coupler to W11
W14	SR	N5245-20043	1	A30 port 3 receiver coupler to W13
W16	SR	N5245-20044	1	A31 port 4 receiver coupler to W15
W18	SR	N5245-20111	1	A32 port 2 receiver coupler to W17
W119	SR	N5224-20021	1	A64 port 1 6-dB attenuator to A33 port 1 coupler
W107	SR	N5224-20005	1	A29 port 1 receiver coupler to A27 mixer brick (R1)/A68 3 dB pad
W115	SR	N5224-20022	1	A33 port 1 coupler to A27 mixer brick (A)
W120	SR	N5224-20020	1	A65 port 3 6-dB attenuator to A34 port 3 coupler
W108	SR	N5224-20024	1	A30 port 3 receiver coupler to A28 mixer brick (R3)
W116	SR	N5224-20016	1	A34 port 3 coupler to A28 mixer brick (C)
W121	SR	N5224-20018	1	A66 port 4 6-dB attenuator to A35 port 4 coupler
W109	SR	N5224-20027	1	A31 port 4 receiver coupler to A28 mixer brick (R4)/A69 3 dB pad
W117	SR	N5224-20026	1	A35 port 4 coupler to A28 mixer brick (D)
W122	SR	N5224-20019	1	A67 port 2 6-dB attenuator to A36 port 2 coupler
W118	SR	N5224-20025	1	A36 port 2 coupler to A27 mixer brick (B)
W110	SR	N5224-20028	1	A32 port 2 receiver coupler to A27 mixer brick (R2)
W51	SR	Refer to "Top Cables, All Cables—All Options" on page 6-20.		
W52	SR	N5245-20013	1	A25 HMA26.5 to A26 splitter
W53	SR	N5245-20023	1	A26 splitter to A27 mixer brick
W54	SR	N5245-20022	1	A26 splitter to A28 mixer brick
W55	SR	N5245-20102	1	A7 port 1 doubler to W56
W56	SR	N5245-20103	1	W55 to rear-panel EXT TSET DRIVE RF OUT (J6)
W57	SR	N5245-20012	1	A27 mixer brick to EXT TSET DRIVE LO OUT (J5)
W61	F	N5242-60017	1	A27 mixer brick (A) to A24 IF multiplexer (P1)
W62	F	N5242-60021	1	A27 mixer brick (R1) to A24 IF multiplexer (P411)
W63	F	N5242-60022	1	A27 mixer brick (R2) to A24 IF multiplexer (P412)
W64	F	N5242-60018	1	A27 mixer brick (B) to A24 IF multiplexer (P201)
W65	F	N5242-60024	1	A28 mixer brick (D) to A24 IF multiplexer (P801)
W66	F	N5242-60019	1	A28 mixer brick (R4) to A24 IF multiplexer (P414)
W67	F	N5242-60020	1	A28 mixer brick (R3) to A24 IF multiplexer (P413)
W68	F	N5242-60023	1	A28 mixer brick (C) to A24 IF multiplexer (P601)
W69-73	F	Refer to "Top Cables, All Cables—All Options" on page 6-20.		
①	-	N5247-20138	1	Dust cap, A28 mixer brick termination

a. SR = semirigid coaxial cable; F = flexible coaxial cable

Figure 6-30 Bottom RF Cables, 4-Port, Option 410

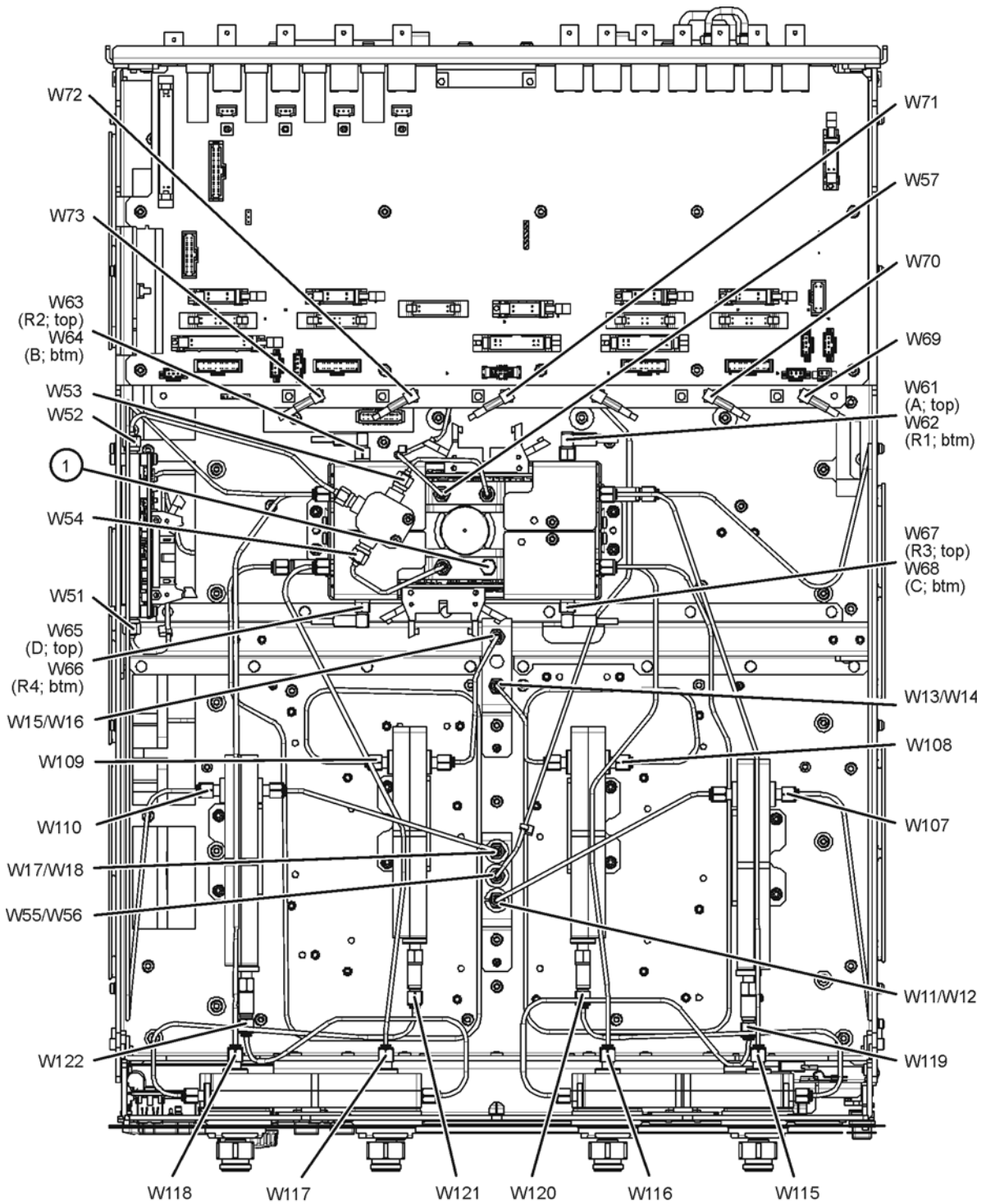

(Some parts removed for clarity.)

N5225_001_626

Bottom Ribbon Cables and Wire Harnesses, 4-Port, Option 410

Reference Designator	Type ^a	Part Number	Description
①	10R	N5242-60005	Rear-panel PWR I/O to A23 test set motherboard J301
②	20R	N5247-60015 Was N5245-60008	A23 test set motherboard J552 to A28 mixer brick (2) J52
③	3W	N5225-60001	A23 test set motherboard J221 to ports 1/3 LED board J1
④	20R	N5247-60015 Was N5245-60008	A23 test set motherboard J551 to A27 mixer brick (1) J52
⑤	3W	N5225-60001	A23 test set motherboard J222 to ports 2/4 LED board J1
⑥	24R	N5230-60014 Was N5242-60011	A23 test set motherboard J209 to A25 HMA26.5 J1
⑦	100R	N5242-60004	A18 system motherboard J1 to A23 test set motherboard J1 to A24 IF multiplexer board J1
⑧	25R	E4410-60160	A18 system motherboard J13 to A23 test set motherboard J545
⑨	36R	8121-0834	Rear-panel HANDLER I/O to A23 test set motherboard J400

a. nR = n wires in a ribbon (flat) cable; nW = n wires in a wire harness

Figure 6-31 Bottom Ribbon Cables and Wire Harnesses, 4-Port, Option 410

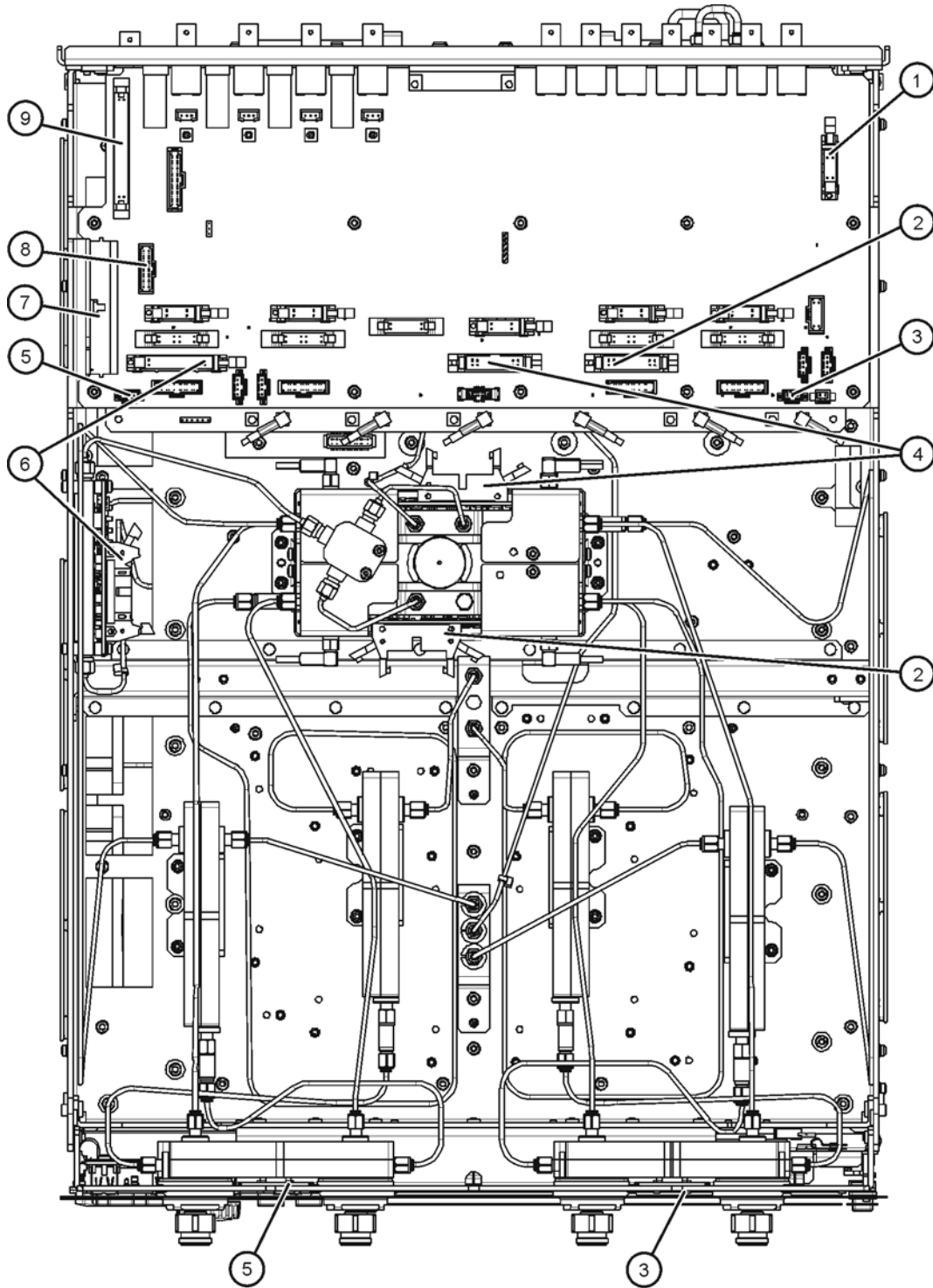

(Some parts removed for clarity.)

N5225_001_627

4-Port Configuration, Option 417

Bottom Assemblies, 4-Port, Option 417

Reference Designator	Part Number ^a	Qty	Description
A23	N5245-60157 <i>Was N5247-60001</i>	1	Test set motherboard
A24	N5240-60062	1	IF multiplexer board
A25	5087-7765	1	LO Multiplier/amplifier 26.5 (HMA26.5)
A26	5067-4086	1	Splitter
A27 A28	5087-7323 <i>5087-6323</i>	2	Mixer brick
A29 A30 A31 A32	5087-7760	4	Test port 1 receiver coupler Test port 3 receiver coupler Test port 4 receiver coupler Test port 2 receiver coupler
A33 A34 A35 A36	5087-7793	4	Test port 1 coupler Test port 3 coupler Test port 4 coupler Test port 2 coupler
A37	5087-7759	1	Reference mixer switch
A38 A39 A40 A41	33325-60016	4	Test port 1 source attenuator Test port 3 source attenuator Test port 4 source attenuator Test port 2 source attenuator
A46 A47 A48 A49	33325-60017	4	Port 1 receiver attenuator Port 3 receiver attenuator Port 4 receiver attenuator Port 2 receiver attenuator
①	N5240-60058	2	Front panel LED board
A69	08490-60039	1	3 dB attenuator (pad) connected to mixer brick (R4)

- a. Part numbers in italic typeface are for rebuilt exchange assemblies. Refer to **“Rebuilt-Exchange Assemblies”** on page 6-5.

Figure 6-32 Bottom Assemblies, 4-Port, Option 417

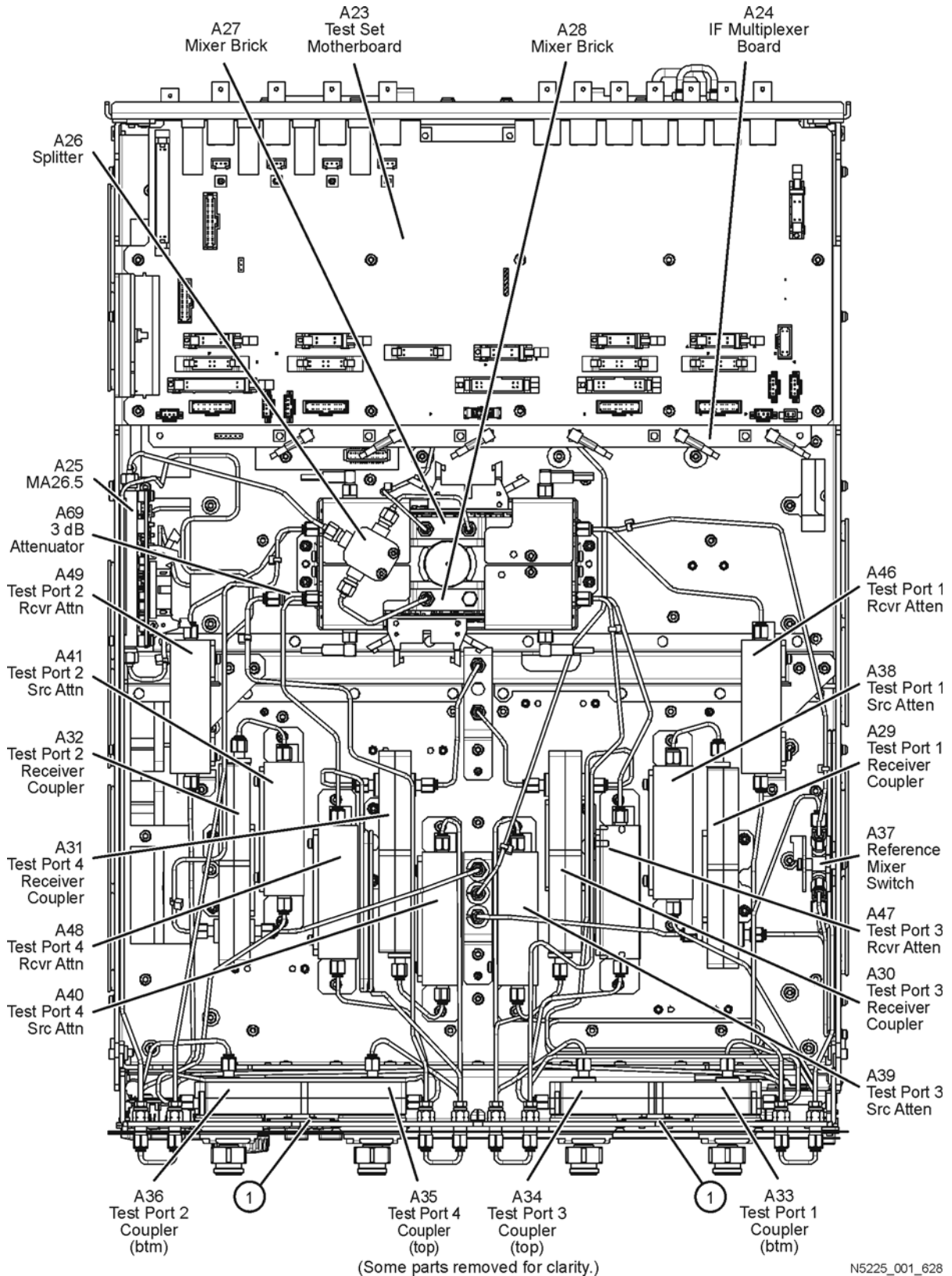

N5225_001_628

Bottom RF Cables, 4-Port, Option 417 (Ports 1 and 2)

Reference Designator	Type ^a	Part Number	Qty	Description
W12	SR	N5245-20050	1	A29 port 1 receiver coupler to W11
W18	SR	N5245-20049	1	A32 port 2 receiver coupler to W17
W20	SR	N5245-20099	1	Front panel port 1 CPLR THRU to A33 port 1 coupler
W21	SR	N5245-20008	1	A29 port 1 receiver coupler to A37 reference mixer switch
W22	SR	N5245-20014	1	A33 port 1 coupler to front-panel Port 1 CPLR ARM
W32	SR	N5245-20097	1	Front panel port 2 CPLR THRU to A36 port 2 coupler
W33	SR	N5245-20010	1	A32 port 2 receiver coupler to front-panel REF 2 SOURCE OUT
W34	SR	N5245-20019	1	A36 port 2 coupler to front-panel Port 2 CPLR ARM
W36	SR	N5245-20155 Was N5245-20104	12	Front panel jumper
W41	SR	N5245-20006	1	A37 reference mixer switch to front-panel REF 1 SOURCE OUT
W42	SR	N5245-20007	1	REF 1 RCVR R1 IN to A37 reference mixer switch
W43	SR	N5245-20009	1	A37 reference mixer switch to A27 mixer brick (R1)
W47	SR	N5245-20115	1	REF 2 RCVR R2 IN to A27 mixer brick (R2)
W51	SR	Refer to "Top Cables, All Cables—All Options" on page 6-20.		
W52	SR	N5245-20013	1	A25 HMA26.5 to A26 splitter
W53	SR	N5245-20023	1	A26 splitter to A27 mixer brick
W56	SR	N5245-20103	1	W55 to rear-panel EXT TSET DRIVE RF OUT (J6)
W57	SR	N5245-20012	1	A27 mixer brick to EXT TSET DRIVE LO OUT (J5)
W61	F	N5242-60017	1	A27 mixer brick (A) to A24 IF multiplexer (P1)
W62	F	N5242-60021	1	A27 mixer brick (R1) to A24 IF multiplexer (P411)
W63	F	N5242-60022	1	A27 mixer brick (R2) to A24 IF multiplexer (P412)
W64	F	N5242-60018	1	A27 mixer brick (B) to A24 IF multiplexer (P201)
W69-73	F	Refer to "Top Cables, All Cables—All Options" on page 6-20.		
W81	SR	N5245-20029	1	A29 port 1 receiver coupler to A38 port 1 source attenuator
W82	SR	N5245-20077	1	A38 port 1 source attenuator to front-panel Port 1 SOURCE OUT
W93	SR	N5245-20029	1	A32 port 2 receiver coupler to A41 port 2 source attenuator
W94	SR	N5245-20031	1	A41 port 2 source attenuator to front-panel Port 2 SOURCE OUT
W97	SR	N5245-20054	1	Front-panel Port 1 RCVR A IN to A46 port 1 receiver attenuator
W98	SR	N5245-20056	1	A46 port 1 receiver attenuator to A27 mixer brick (A)
W103	SR	N5245-20055	1	Port 2 RCVR B IN to A49 port 2 receiver attenuator
W104	SR	N5245-20057	1	A49 port 2 receiver attenuator to A27 mixer brick (B)

a. SR = semirigid coaxial cable; F = flexible coaxial cable

Figure 6-33 Bottom RF Cables, 4-Port, Option 417 (Ports 1 and 2)

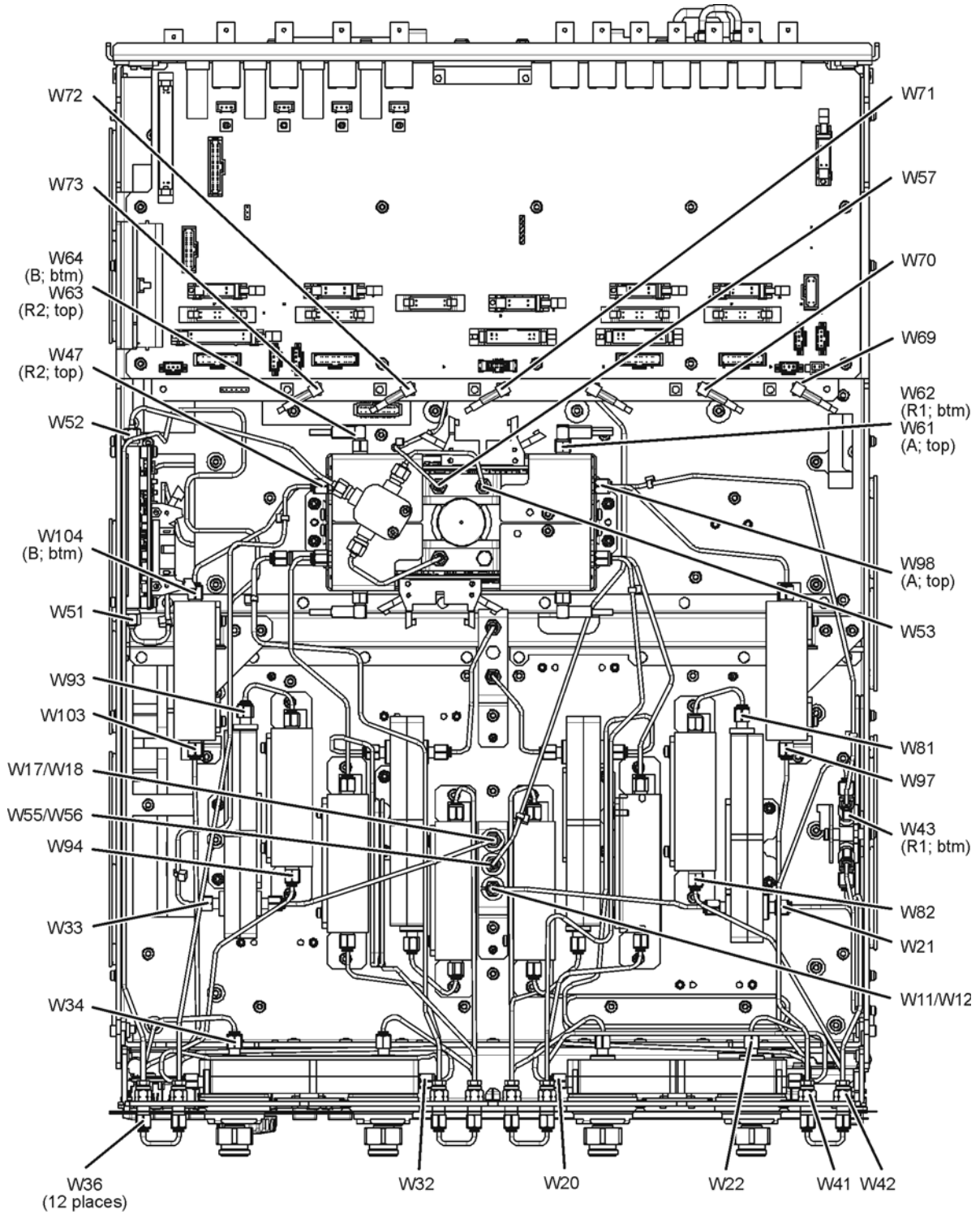

(Some parts removed for clarity.)

N5225_001_629

Bottom RF Cables, 4-Port, Option 417 (Ports 3 and 4)

Reference Designator	Type ^a	Part Number	Qty	Description
W14	SR	N5245-20043	1	A30 port 3 receiver coupler to W13
W16	SR	N5245-20044	1	A31 port 4 receiver coupler to W15
W24	SR	N5245-20098	1	Front panel port 3 CPLR THRU to A34 port 3 coupler
W25	SR	N5245-20116	1	A30 port 3 receiver coupler to front-panel REF 3 SOURCE OUT
W26	SR	N5245-20015	1	A34 port 3 coupler to front-panel Port 3 CPLR ARM
W28	SR	N5245-20096	1	Front panel port 4 CPLR THRU to A35 port 4 coupler
W29	SR	N5245-20117	1	A31 port 4 receiver coupler to front-panel REF 4 SOURCE OUT
W30	SR	N5245-20018	1	A35 port 4 coupler to front-panel Port 4 CPLR ARM
W44	SR	N5245-20020	1	REF 3 RCVR R3 IN to A28 mixer brick (R3)
W45	SR	N5245-20021	1	REF 4 RCVR R4 IN to A69 3 dB pad on A28 mixer brick (R4)
W54	SR	N5245-20022	1	A26 splitter to A28 mixer brick
W65	F	N5242-60024	1	A28 mixer brick (D) to A24 IF multiplexer (P801)
W66	F	N5242-60019	1	A28 mixer brick (R4) to A24 IF multiplexer (P414)
W67	F	N5242-60020	1	A28 mixer brick (R3) to A24 IF multiplexer (P413)
W68	F	N5242-60023	1	A28 mixer brick (C) to A24 IF multiplexer (P601)
W85	SR	N5245-20026	1	A30 port 3 receiver coupler to A39 port 3 source attenuator
W86	SR	N5245-20027	1	A39 port 3 source attenuator to front-panel Port 3 SOURCE OUT
W89	SR	N5245-20026	1	A31 port 4 receiver coupler to A40 port 4 source attenuator
W90	SR	N5245-20028	1	A40 port 4 source attenuator to front-panel Port 4 SOURCE OUT
W99	SR	N5245-20073	1	Port 3 RCVR C IN to A47 port 3 receiver attenuator
W100	SR	N5245-20066	1	A47 port 3 receiver attenuator to A28 mixer brick (C)
W101	SR	N5245-20074	1	Port 4 RCVR D IN to A48 port 4 receiver attenuator
W102	SR	N5245-20075	1	A48 port 4 receiver attenuator to A28 mixer brick (D)
①	-	N5247-20138	1	Dust cap, A28 mixer brick termination

a. SR = semirigid coaxial cable; F = flexible coaxial cable

Figure 6-34 Bottom RF Cables, 4-Port, Option 417 (Ports 3 and 4)

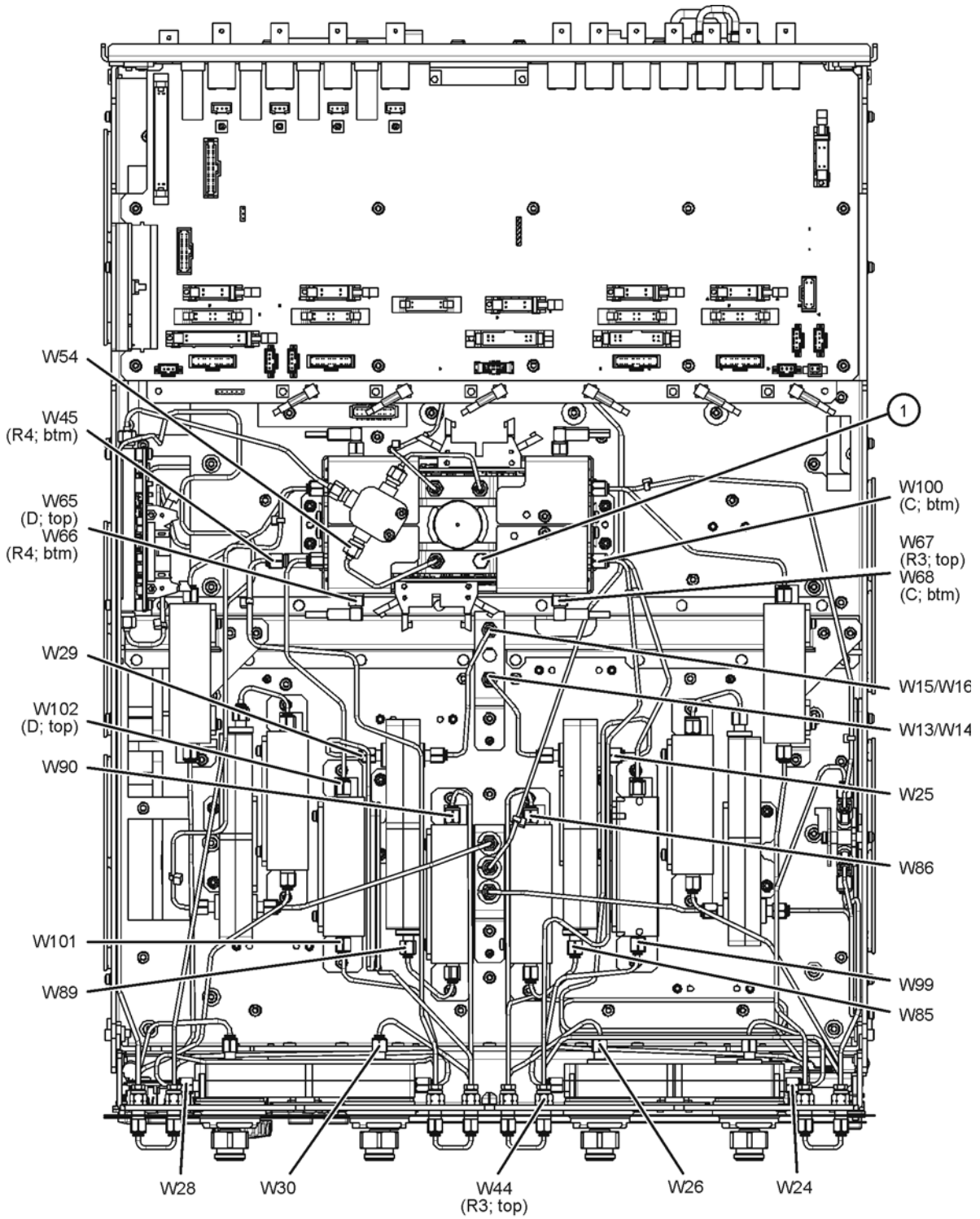

(Some parts removed for clarity.)

N5225_001_630

Bottom Ribbon Cables and Wire Harnesses, 4-Port, Option 417

Reference Designator	Type ^a	Part Number	Description
①	10R	N5242-60005	Rear-panel PWR I/O to A23 test set motherboard J301
②	16R	N5245-60006	A23 test set motherboard J549 to A38 port 1 source attenuator
③	10R	N5245-60026 Was 8121-0982, or N5242-60007	A23 test set motherboard J205 to A46 port 1 receiver attenuator
④	2W	8121-0966	A23 test set motherboard J554 to A37 reference mixer switch
⑤	3W	N5225-60001	A23 test set motherboard J221 to ports 1/3 LED board J1
⑥	20R	N5247-60015 Was N5245-60008	A23 test set motherboard J551 to A27 mixer brick (1) J52
⑦	10R	N5245-60026 Was 8121-0982, or N5242-60007	A23 test set motherboard J206 to A47 port 3 receiver attenuator
⑧	16R	N5245-60006	A23 test set motherboard J547 to A39 port 3 source attenuator
⑨	3W	N5225-60001	A23 test set motherboard J222 to ports 2/4 LED board J1
⑩	16R	N5245-60006	A23 test set motherboard J548 to A40 port 4 source attenuator
⑪	10R	N5245-60026 Was 8121-0982, or N5242-60007	A23 test set motherboard J207 to A48 port 4 receiver attenuator
⑫	10R	N5245-60026 Was 8121-0982, or N5242-60007	A23 test set motherboard J208 to A49 port 2 receiver attenuator
⑬	16R	N5245-60006	A23 test set motherboard J546 to A41 port 2 source attenuator
⑭	20R	N5247-60015 Was N5245-60008	A23 test set motherboard J552 to A28 mixer brick (2) J52
⑮	24R	N5230-60014 Was N5242-60011	A23 test set motherboard J209 to A25 HMA26.5 J1
⑯	100R	N5242-60004	A18 system motherboard J1 to A23 test set motherboard J1 to A24 IF multiplexer board J1
⑰	25R	E4410-60160	A18 system motherboard J13 to A23 test set motherboard J545
⑱	36R	8121-0834	Rear-panel HANDLER I/O to A23 test set motherboard J400

a. nR = n wires in a ribbon (flat) cable; nW = n wires in a wire harness

Figure 6-35 Bottom Ribbon Cables & Wire Harnesses, 4-Port, Option 417

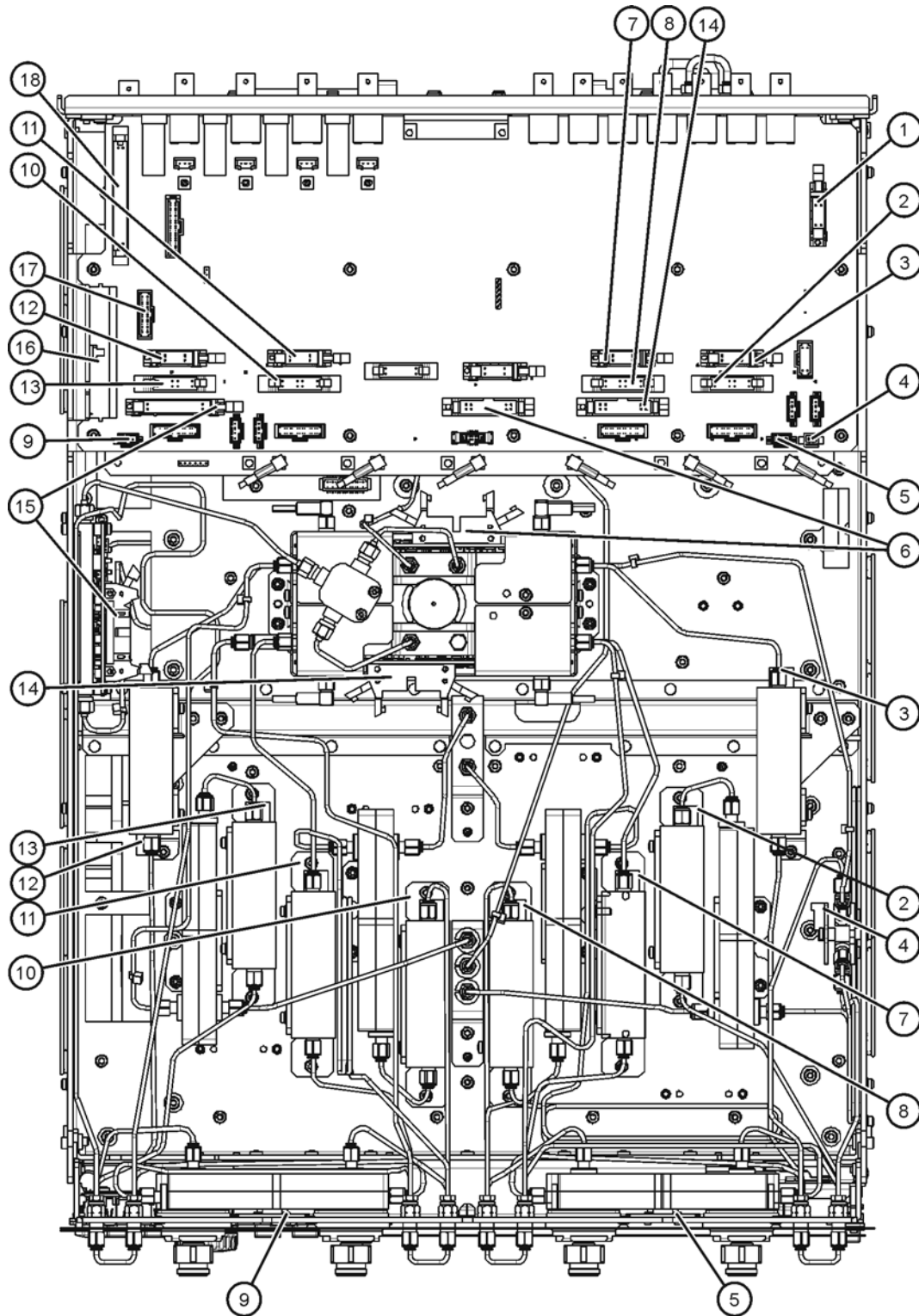

(Some parts removed for clarity.)

N5225_001_631

4-Port Configuration, Option 419

Bottom Assemblies, 4-Port, Option 419

Reference Designator	Part Number ^a	Qty	Description
A23	N5245-60157 <i>Was N5247-60001</i>	1	Test set motherboard
A24	N5240-60062	1	IF multiplexer board
A25	5087-7765	1	LO Multiplier/amplifier 26.5 (HMA26.5)
A26	5067-4086	1	Splitter
A27 A28	5087-7323 <i>5087-6323</i>	2	Mixer brick
A29 A30 A31 A32	5087-7760	4	Test port 1 receiver coupler Test port 3 receiver coupler Test port 4 receiver coupler Test port 2 receiver coupler
A33 A34 A35 A36	5087-7793	4	Test port 1 coupler Test port 3 coupler Test port 4 coupler Test port 2 coupler
A37	5087-7759	1	Reference mixer switch
A38 A39 A40 A41	33325-60016	4	Test port 1 source attenuator Test port 3 source attenuator Test port 4 source attenuator Test port 2 source attenuator
A42 A43 A44 A45	5087-7789	4	Test port 1 bias tee (includes wire harness) Test port 3 bias tee (includes wire harness) Test port 4 bias tee (includes wire harness) Test port 2 bias tee (includes wire harness)
A46 A47 A48 A49	33325-60017	4	Port 1 receiver attenuator Port 3 receiver attenuator Port 4 receiver attenuator Port 2 receiver attenuator
①	N5240-60058	2	Front panel LED board
A69	08490-60039	1	3 dB attenuator (pad) connected to mixer brick (R4)

a. Part numbers in italic typeface are for rebuilt exchange assemblies. Refer to **“Rebuilt-Exchange Assemblies”** on page 6-5.

Figure 6-36 Bottom Assemblies, 4-Port, Option 419

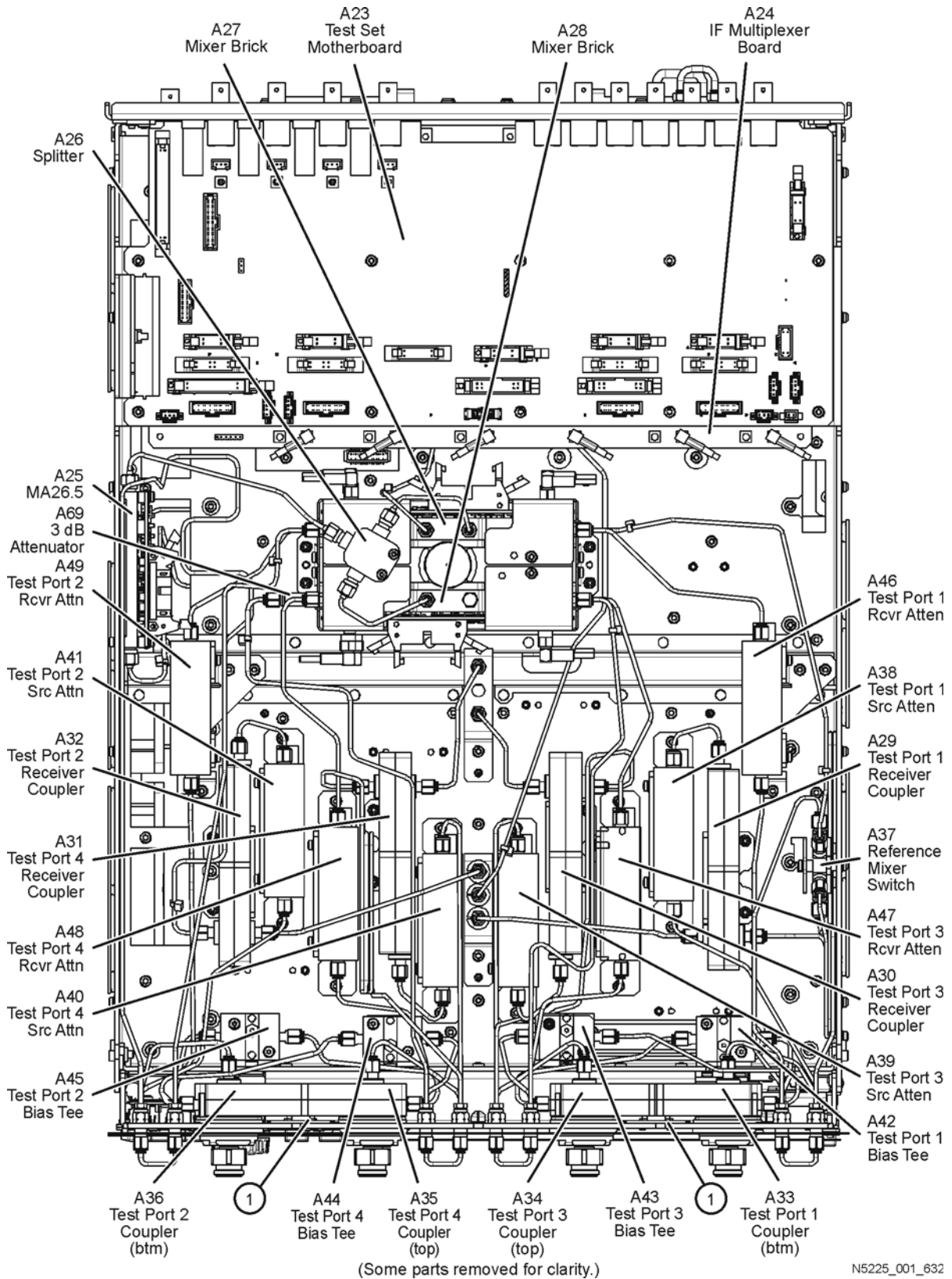

N5225_001_632

Bottom RF Cables, 4-Port, Option 419 (Ports 1 and 2)

Reference Designator	Type ^a	Part Number	Qty	Description
W12	SR	N5245-20050	1	A29 port 1 receiver coupler to W11
W18	SR	N5245-20049	1	A32 port 2 receiver coupler to W17
W21	SR	N5245-20008	1	A29 port 1 receiver coupler to A37 reference mixer switch
W22	SR	N5245-20014	1	A33 port 1 coupler to front-panel Port 1 CPLR ARM
W33	SR	N5245-20010	1	A32 port 2 receiver coupler to front-panel REF 2 SOURCE OUT
W34	SR	N5245-20019	1	A36 port 2 coupler to front-panel Port 2 CPLR ARM
W36	SR	N5245-20155 Was N5245-20104	12	Front panel jumper
W41	SR	N5245-20006	1	A37 reference mixer switch to front-panel REF 1 SOURCE OUT
W42	SR	N5245-20007	1	REF 1 RCVR R1 IN to A37 reference mixer switch
W43	SR	N5245-20009	1	A37 reference mixer switch to A27 mixer brick (R1)
W47	SR	N5245-20115	1	REF 2 RCVR R2 IN to A27 mixer brick (R2)
W51	SR	Refer to "Top Cables, All Cables—All Options" on page 6-20.		
W52	SR	N5245-20013	1	A25 HMA26.5 to A26 splitter
W53	SR	N5245-20023	1	A26 splitter to A27 mixer brick
W56	SR	N5245-20103	1	W55 to rear-panel EXT TSET DRIVE RF OUT (J6)
W57	SR	N5245-20012	1	A27 mixer brick to EXT TSET DRIVE LO OUT (J5)
W61	F	N5242-60017	1	A27 mixer brick (A) to A24 IF multiplexer (P1)
W62	F	N5242-60021	1	A27 mixer brick (R1) to A24 IF multiplexer (P411)
W63	F	N5242-60022	1	A27 mixer brick (R2) to A24 IF multiplexer (P412)
W64	F	N5242-60018	1	A27 mixer brick (B) to A24 IF multiplexer (P201)
W69-73	F	Refer to "Top Cables, All Cables—All Options" on page 6-20.		
W81	SR	N5245-20029	1	A29 port 1 receiver coupler to A38 port 1 source attenuator
W82	SR	N5245-20077	1	A38 port 1 source attenuator to front-panel Port 1 SOURCE OUT
W83	SR	N5245-20076	1	Front-panel Port 1 CPLR THRU to A42 port 1 bias tee
W84	SR	N5245-20085	1	A33 port 1 coupler to A42 port 1 bias tee
W93	SR	N5245-20029	1	A32 port 2 receiver coupler to A41 port 2 source attenuator
W94	SR	N5245-20031	1	A41 port 2 source attenuator to front-panel Port 2 SOURCE OUT
W95	SR	N5245-20030	1	Port 2 CPLR THRU to A45 port 2 bias tee
W96	SR	N5245-20087	1	A45 port 2 bias tee to A36 port 2 coupler
W97	SR	N5245-20054	1	Front-panel Port 1 RCVR A IN to A46 port 1 receiver attenuator
W98	SR	N5245-20056	1	A46 port 1 receiver attenuator to A27 mixer brick (A)
W103	SR	N5245-20055	1	Port 2 RCVR B IN to A49 port 2 receiver attenuator
W104	SR	N5245-20057	1	A49 port 2 receiver attenuator to A27 mixer brick (B)

a. SR = semirigid coaxial cable; F = flexible coaxial cable

Figure 6-37 Bottom RF Cables, 4-Port, Option 419 (Ports 1 and 2)

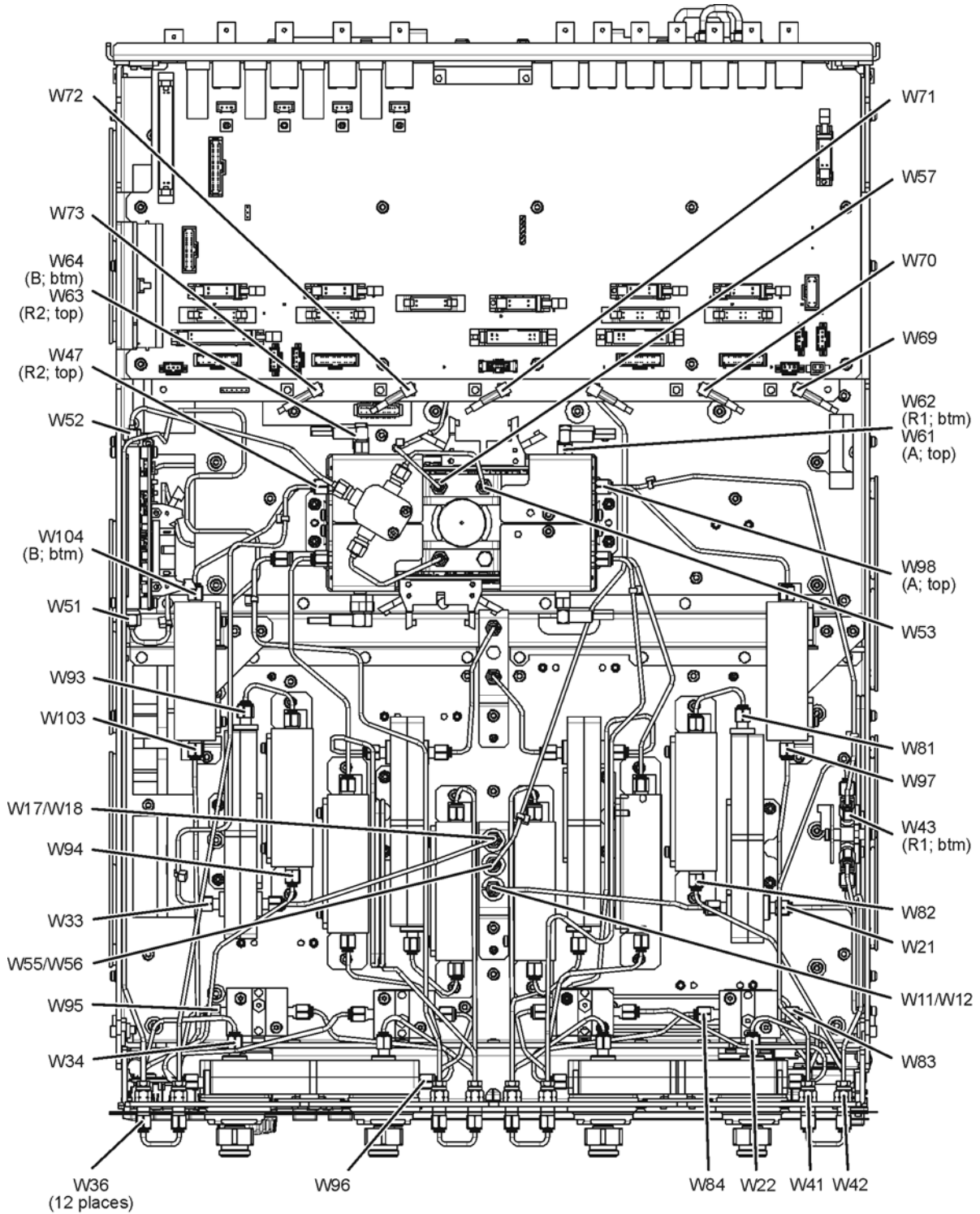

(Some parts removed for clarity.)

N5225_001_633

Bottom RF Cables, 4-Port, Option 419 (Ports 3 and 4)

Reference Designator	Type ^a	Part Number	Qty	Description
W14	SR	N5245-20043	1	A30 port 3 receiver coupler to W13
W16	SR	N5245-20044	1	A31 port 4 receiver coupler to W15
W25	SR	N5245-20116	1	A30 port 3 receiver coupler to front-panel REF 3 SOURCE OUT
W26	SR	N5245-20015	1	A34 port 3 coupler to front-panel Port 3 CPLR ARM
W29	SR	N5245-20117	1	A31 port 4 receiver coupler to front-panel REF 4 SOURCE OUT
W30	SR	N5245-20018	1	A35 port 4 coupler to front-panel Port 4 CPLR ARM
W44	SR	N5245-20020	1	REF 3 RCVR R3 IN to A28 mixer brick (R3)
W45	SR	N5245-20021	1	REF 4 RCVR R4 IN to A69 3 dB pad on A28 mixer brick (R4)
W54	SR	N5245-20022	1	A26 splitter to A28 mixer brick
W65	F	N5242-60024	1	A28 mixer brick (D) to A24 IF multiplexer (P801)
W66	F	N5242-60019	1	A28 mixer brick (R4) to A24 IF multiplexer (P414)
W67	F	N5242-60020	1	A28 mixer brick (R3) to A24 IF multiplexer (P413)
W68	F	N5242-60023	1	A28 mixer brick (C) to A24 IF multiplexer (P601)
W85	SR	N5245-20026	1	A30 port 3 receiver coupler to A39 port 3 source attenuator
W86	SR	N5245-20027	1	A39 port 3 source attenuator to front-panel Port 3 SOURCE OUT
W87	SR	N5245-20089	1	Port 3 CPLR THRU to A43 port 3 bias tee
W88	SR	N5245-20086	1	A43 port 3 bias tee to A34 port 3 coupler
W89	SR	N5245-20026	1	A31 port 4 receiver coupler to A40 port 4 source attenuator
W90	SR	N5245-20028	1	A40 port 4 source attenuator to front-panel Port 4 SOURCE OUT
W91	SR	N5245-20090	1	Port 4 CPLR THRU to A44 port 4 bias tee
W92	SR	N5245-20088	1	A44 port 4 bias tee to A35 port 4 coupler
W99	SR	N5245-20073	1	Port 3 RCVR C IN to A47 port 3 receiver attenuator
W100	SR	N5245-20066	1	A47 port 3 receiver attenuator to A28 mixer brick (C)
W101	SR	N5245-20074	1	Port 4 RCVR D IN to A48 port 4 receiver attenuator
W102	SR	N5245-20075	1	A48 port 4 receiver attenuator to A28 mixer brick (D)
①	-	N5247-20138	1	Dust cap, A28 mixer brick termination

a. SR = semirigid coaxial cable; F = flexible coaxial cable

Figure 6-38 Bottom RF Cables, 4-Port, Option 419 (Ports 3 and 4)

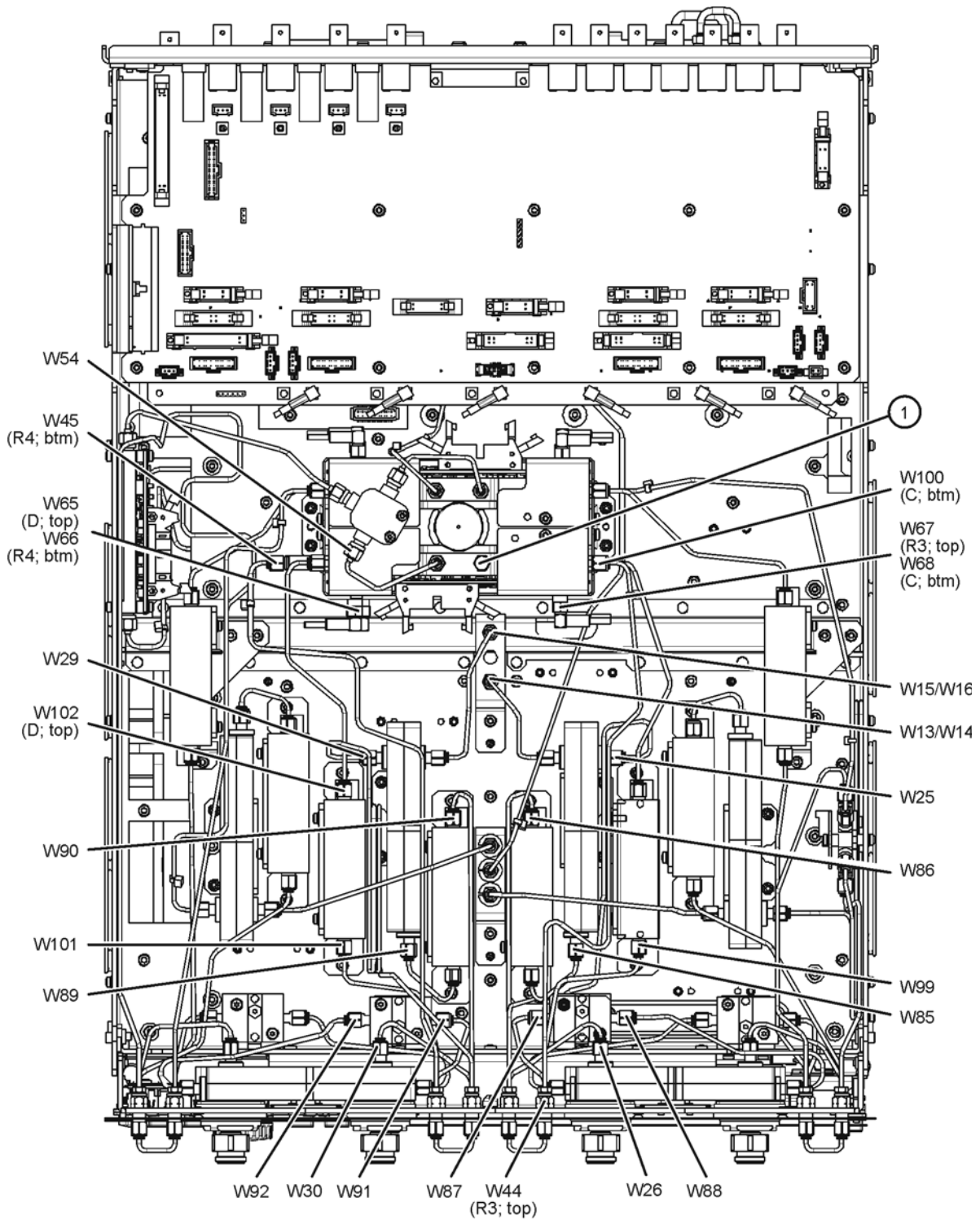

(Some parts removed for clarity.)

N5225_001_634

Bottom Ribbon Cables and Wire Harnesses, 4-Port, Option 419

Reference Designator	Type ^a	Part Number	Description
①	10R	N5242-60005	Rear-panel PWR I/O to A23 test set motherboard J301
②	16R	N5245-60006	A23 test set motherboard J549 to A38 port 1 source attenuator
③	10R	N5245-60026 Was 8121-0982, or N5242-60007	A23 test set motherboard J205 to A46 port 1 receiver attenuator
④	2W	8121-0966	A23 test set motherboard J554 to A37 reference mixer switch
⑤	3W	N5225-60001	A23 test set motherboard J221 to ports 1/3 LED board J1
⑥	20R	N5247-60015 Was N5245-60008	A23 test set motherboard J551 to A27 mixer brick (1) J52
⑦	10R	N5245-60026 Was 8121-0982, or N5242-60007	A23 test set motherboard J206 to A47 port 3 receiver attenuator
⑧	16R	N5245-60006	A23 test set motherboard J547 to A39 port 3 source attenuator
⑨	2W	P/O bias tee	A23 test set motherboard J541 to A42 port 1 bias tee
⑩	2W	P/O bias tee	A23 test set motherboard J543 to A43 port 3 bias tee
⑪	2W	P/O bias tee	A23 test set motherboard J544 to A44 port 4 bias tee
⑫	3W	N5225-60001	A23 test set motherboard J222 to ports 2/4 LED board J1
⑬	2W	P/O bias tee	A23 test set motherboard J542 to A45 port 2 bias tee
⑭	16R	N5245-60006	A23 test set motherboard J548 to A40 port 4 source attenuator
⑮	10R	N5245-60026 Was 8121-0982, or N5242-60007	A23 test set motherboard J207 to A48 port 4 receiver attenuator
⑯	10R	N5245-60026 Was 8121-0982, or N5242-60007	A23 test set motherboard J208 to A49 port 2 receiver attenuator
⑰	16R	N5245-60006	A23 test set motherboard J546 to A41 port 2 source attenuator
⑱	20R	N5247-60015 Was N5245-60008	A23 test set motherboard J552 to A28 mixer brick (2) J52
⑲	24R	N5230-60014 Was N5242-60011	A23 test set motherboard J209 to A25 HMA26.5 J1
⑳	100R	N5242-60004	A18 system motherboard J1 to A23 test set motherboard J1 to A24 IF multiplexer board J1
㉑	25R	E4410-60160	A18 system motherboard J13 to A23 test set motherboard J545
㉒	36R	8121-0834	Rear-panel HANDLER I/O to A23 test set motherboard J400

a. nR = n wires in a ribbon (flat) cable; nW = n wires in a wire harness

Figure 6-39 Bottom Ribbon Cables and Wire Harnesses, 4-Port, Option 419

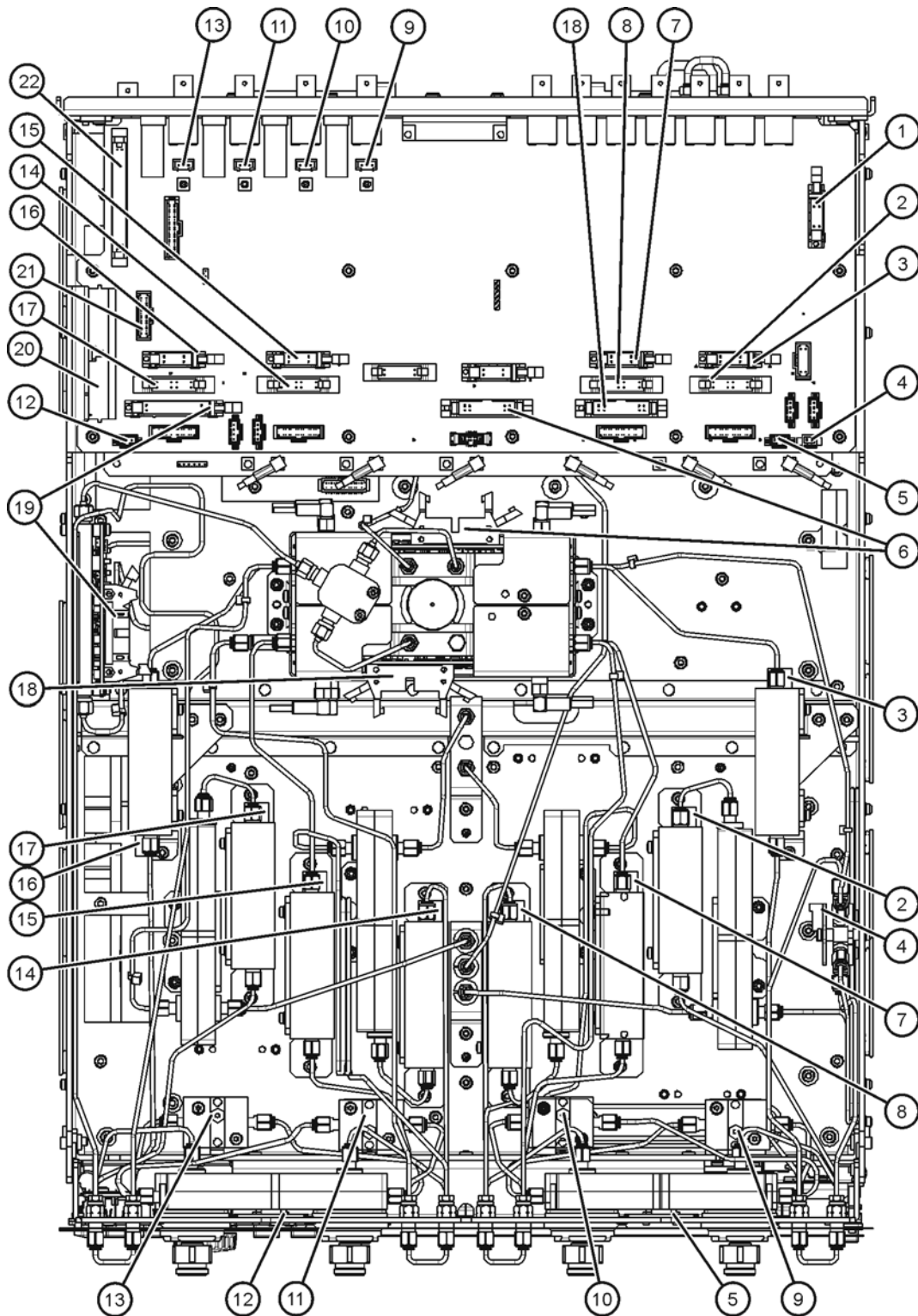

(Some parts removed for clarity.)

N5225_001_635

Rear Panel Assembly, All Options

Item Number	Part Number	Qty	Description
①	N5245-00028	1	Power supply rear panel bracket
②	0515-0372	--	Machine screw, M3.0 x 8, pan head (To attach: CPU assy to ejector arms and left and right side inner brackets, RP to chassis, power supply bracket to the power supply and rear panel, handler I/O cable to rear panel, test set deck to rear panel.)
③	N5242-60044	1	Hard drive module
④	Rear foot and screw (Refer to “External Hardware and Miscellaneous Parts, All Options” on page 6-96.)		
⑤	6960-0149	1	Hole plug
⑥	2190-0958 Was 2190-0034	--	Lock washer
⑦	0380-0644	--	Jack screw
⑧	N5245-00008	1	Rear panel
⑨	3050-2330	--	Lock washer (For A24 IF MUX board connectors.)
⑩	2950-0414	--	Hex nut (For A24 IF MUX board connectors.)
⑪	2190-0584	--	Lock washer
⑫	0380-4670	--	Jack screw, 0.442 inch length
	1251-7812	--	Jack screw, 0.5 inch length
⑬	N5242-60005	1	PWR I/O cable assembly
⑭	1253-8234	1	Connector-D-subminiature filter adapter
⑮	9170-2235	1	Ferrite for PWR I/O cable assembly
⑯	1810-0118	2	Termination, 50 ohm load
⑰	8121-0834	1	HANDLER I/O cable assembly
⑱	9170-2236	1	Ferrite for HANDLER I/O cable assembly
⑲	2190-0068	--	Lock washer
⑳	2950-0054	--	Hex nut
㉑	Bottom foot (Refer to “External Hardware and Miscellaneous Parts, All Options” on page 6-96.)		
㉒	6960-0523	9	Hole plug
㉓	2190-0102	--	Lock washer
㉔	2950-0035	--	Hex nut

Item Number	Part Number	Qty	Description
25	8120-5063	2	BNC cable

Figure 6-40 Rear Panel Assembly, All Options

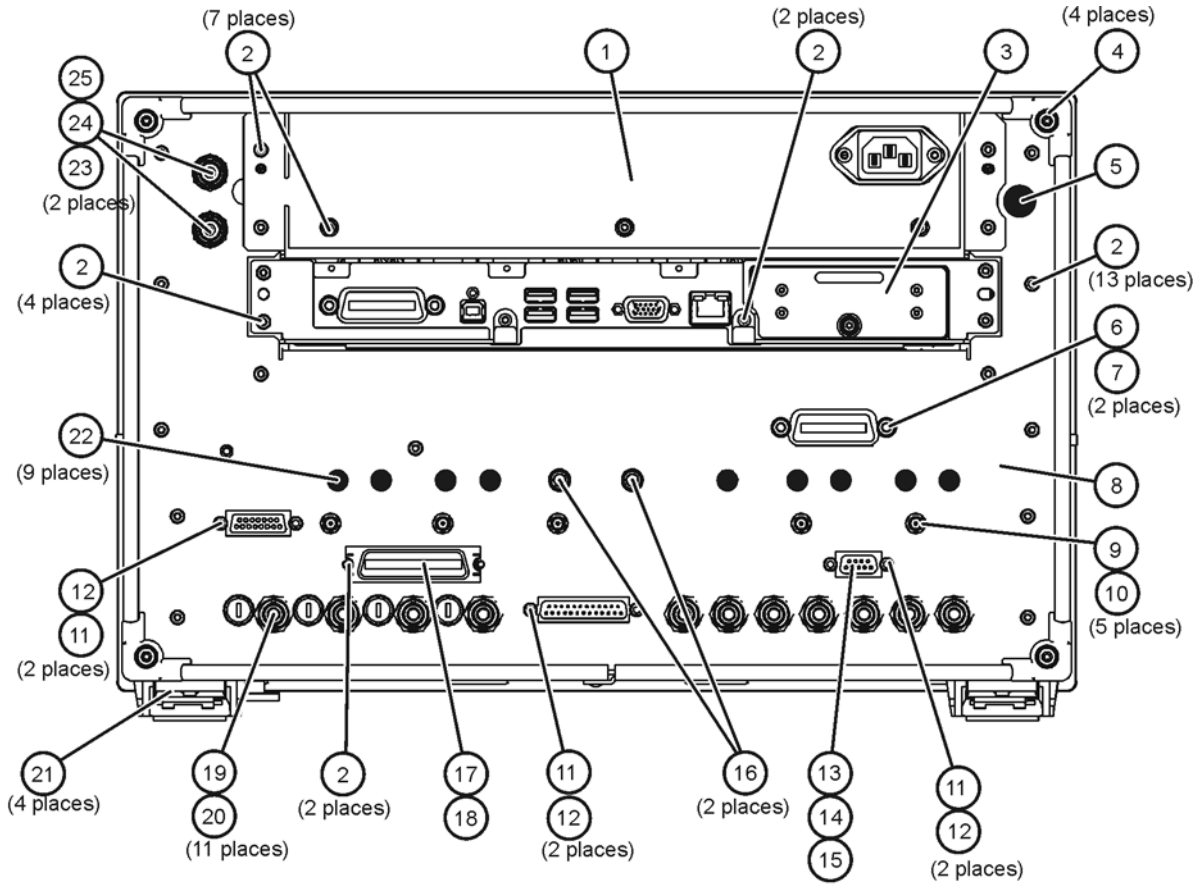

N5225_001_636

Fan Assemblies, All Options

Reference Designator	Part Number	Qty	Description
B1	3160-4199	5	Fan
①	3160-0281 Was 3160-4198	5	Fan guard
②	0361-1272	20	Fan rivet
③	N5245-00006	1	Fan bracket (for 2 fans)
④	N5245-00003	1	Fan bracket (for 3 fans)
⑤	0515-0372	--	Machine screw, M3.0 x 8, pan head (To attach: 7 to attach the 2-fan assy to chassis, 5 to attach the 3-fan assy to chassis.)
⑥	Chassis (Refer to “Internal Hardware and Miscellaneous Parts, All Options” on page 6-94.)		
⑦	E4440-00021	2	EMI shield, round, adhesive. (Located on center hub of 2 fans only.)

Figure 6-41 Fan Assemblies, Side View, All Options

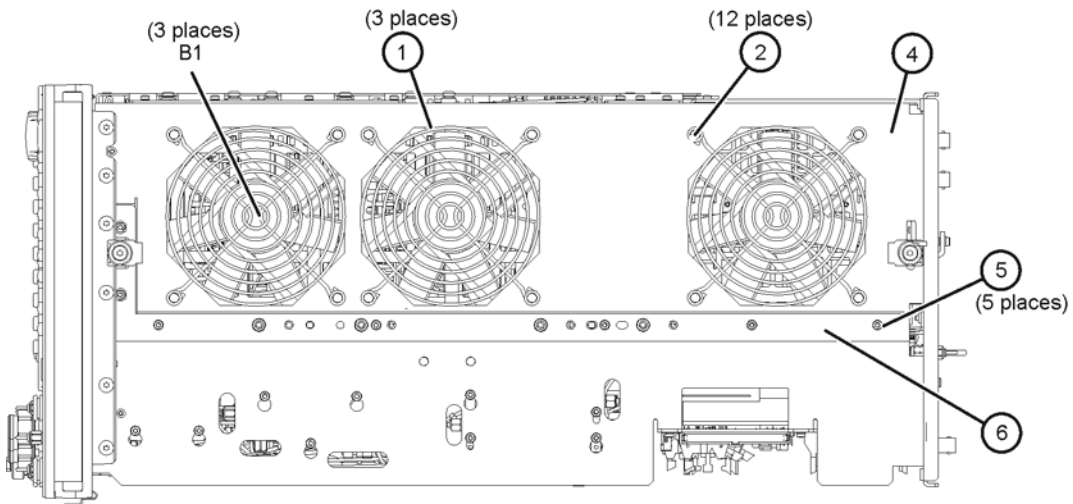
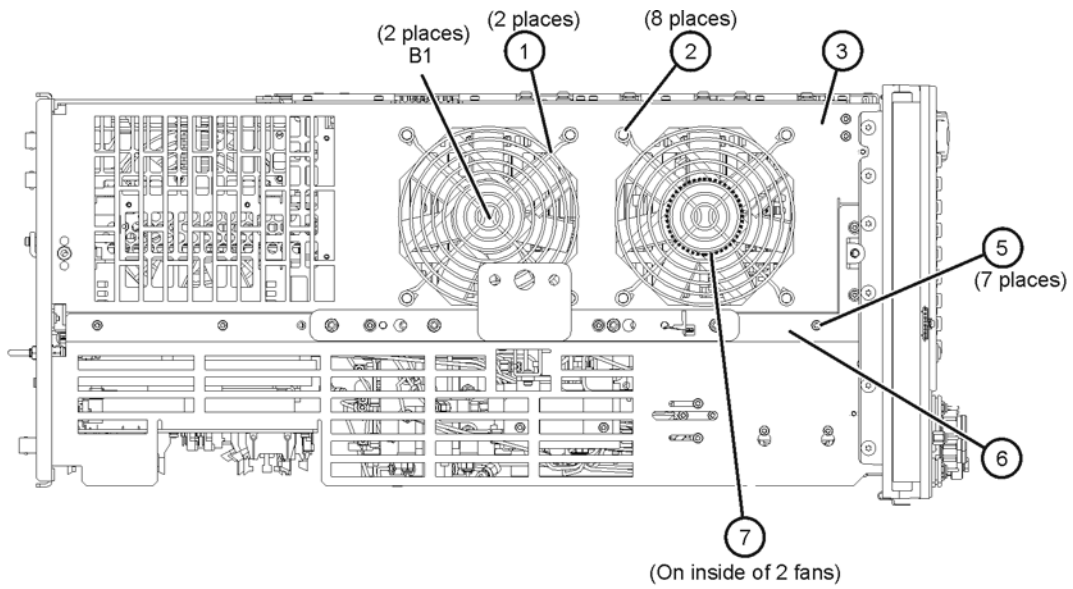

N5225_001_639

Top Hardware and Miscellaneous Parts, All Options

Reference Designator	Part Number	Qty	Description
①	W1312-00062	1	Bracket, power supply
②	0515-0375	--	Machine screw, M3.0 x 16, pan head (To attach midplane board to midplane bracket.)
③	0515-1946	--	Machine screw, M3.0 x 6, flat head (To attach power supply bracket to power supply.)
④	0515-0372	--	Machine screw, M3.0 x 8, pan head (4 to attach power supply bracket to inner panels, 6 to attach A18 system motherboard to chassis.)
⑤	0400-0353	6	Midplane board grommets
⑥	5041-7250	2	Wire loom
⑦	0515-0380	--	Machine screw, M4.0 x 10, pan head (To attach all doubler and all source boards to inner panels.)
not shown	N5247-20136	2	Bracket, 26.5 GHz source board (A5 and A10)
not shown	0515-2078	--	Machine screw, M3.0 x 20, flat head (To attach source bracket to source (1) and source (2).)
not shown	0515-0666	--	Machine screw, M3.0 x 18, pan head (To attach source bracket to source (1) and source (2).)

Figure 6-42 Top Hardware and Miscellaneous Parts, Top View, All Options

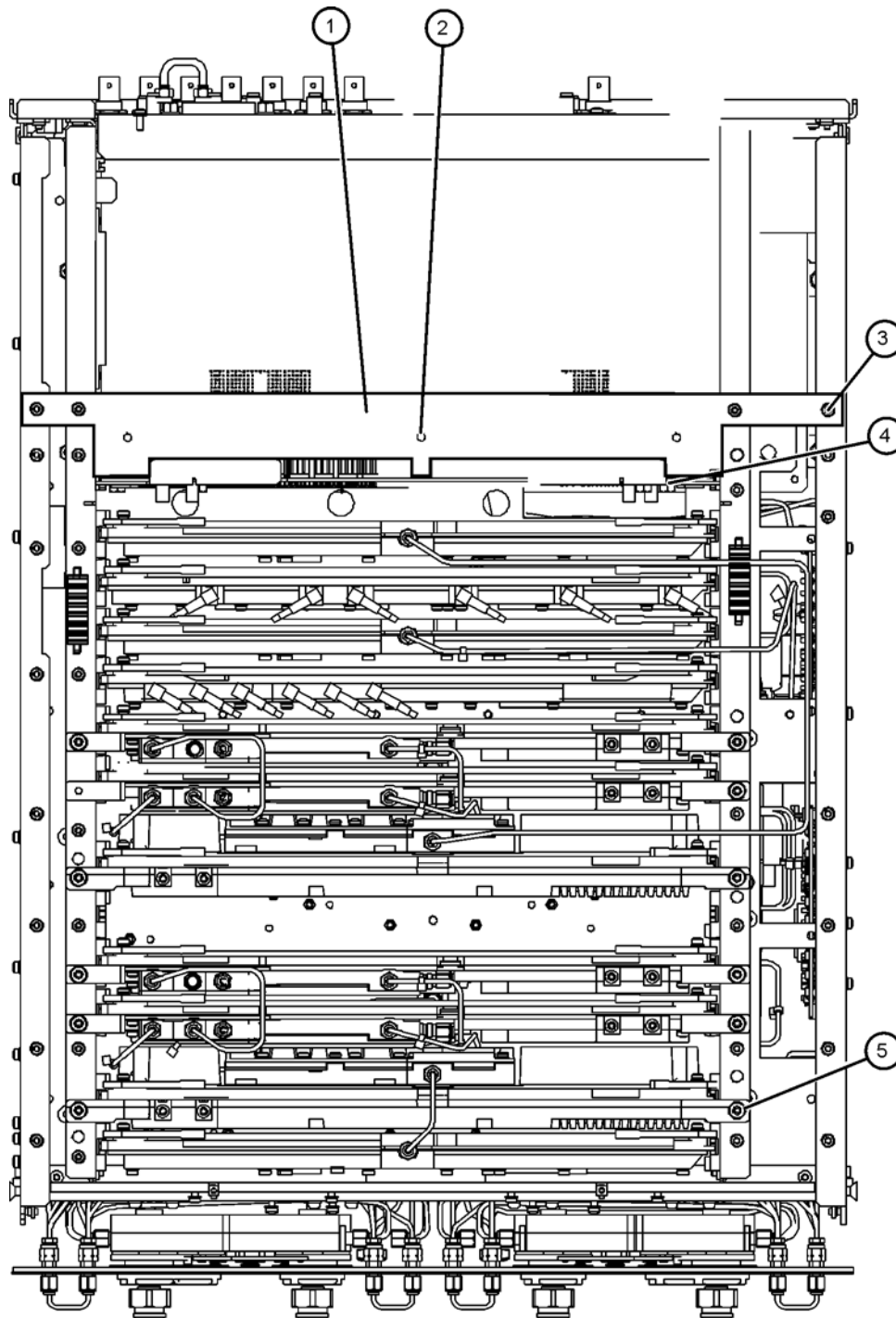

N5225_001_637

Bottom Hardware and Miscellaneous Parts

Reference Designator	Part Number	Qty	Description
①	0515-1227	--	Machine screw, M3.0 x 6, flat head (To attach test set front sub panel.)
②	0515-2994	--	Machine screw, M3.0 x 0.5, pan head (8 to attach A42–A45 bias tees to their brackets.)
③	N5245-00017	4	Bracket (For A29–A32 test port couplers.)
④	0515-0430	--	Machine screw M3.0 x 6 pan head (To attach: A47 & A48 receiver attenuator brackets to test set deck, source attenuator brackets to test set deck.)
⑤	0515-0372	--	Machine screw, M3.0 x 8, pan head (To attach: A23 test set motherboard to test set deck and stabilizer bracket, stabilizer bracket to A24 IF mux board, A38–A41 source attenuators to their brackets, A46–A49 receiver attenuators to their brackets, A46 & A49 receiver attenuator brackets to test set deck, test set deck to chassis, shields to mixer bricks, A25 HMA26.5 to inner bracket, A37 reference mixer switch to its bracket, and coupler plate assy to test set deck front, bias tee brackets to the chassis.)
⑥	0515-2007	--	Machine screw M3.0 x 14 (To attach splitter to top of mixer brick mounting block.)
⑦	08490-60039	1	A69 3 dB pad (For A28 mixer brick R4.)
⑧	N5245-20002	1	Mounting block (For A27 and A28 mixer bricks.)
⑨	0515-0374	--	Machine screw M3.0 x 10 pan head (To attach mixer brick mounting block and receiver coupler mounting brackets; reference mixer switch to test set deck.)
⑩	0515-0667	--	Machine screw M3.0 x 20 pan head (To attach mixer bricks to mounting block.)
⑪	N5245-20125	8	Gap pad (Between each mixer brick and its shield.)
	N5245-00023	2	Mixer brick shield
⑫	N5224-00002	1	Test set deck
⑬	0515-0664	--	Machine screw (To attach bracket (for semi rigid cables) to test set deck.)
⑭	N5225-00001	2	Bracket (For A46 port 1 and A49 port 2 receiver attenuators.)
⑮	0515-1602	--	Machine screw, M2.0 x 6, flat head (To attach receiver couplers to brackets.)
⑯	N5245-00024	1	Bracket (For A37 reference mixer switch.)
⑰	N5245-00022	2	Bracket (For semi rigid cables; only 1 used for 2-port, both used for 4-port.)
⑱	N5245-00015	6	Bracket (For A47 port 3 & A48 port 4 rcvr attenuators & all src attenuators.)
⑲	N5227-00001	1	Test set front plate, 2-port models without front panel jumpers
	N5224-00004	1	Test set front plate, 2-port models with front panel jumpers
	N5224-00005	1	Test set front plate, all 4-port models
⑳	5022-1087	4	Test port coupler dress nut (One for each coupler.)
㉑	0515-1521	--	Machine screw, M3.0 x 5, flat head (To attach front panel LED boards.)
not shown	0515-0669	--	Machine screw, M4.0 x 0.7, pan head (To attach A24 IF MUX to t. set deck.
	N5245-00011	4	Bracket (For all bias tees.)
	E4403-20033	4	Gap pad (Between each coupler and test set front sub panel.)
	N5242-00019	1	Stabilizer bracket (Between A23 test set motherboard and A24 IF mux board.)
	0460-2725	2	Coupler vibration mount (Between port 1 & port 2 couplers & test set front sub panel.)
	N5242-00029	2	Protective guard for front panel jumpers
	N5242-00030	2	Protective guard for front panel jumpers (4-port models only.)

Figure 6-43 Bottom Hardware and Miscellaneous Parts

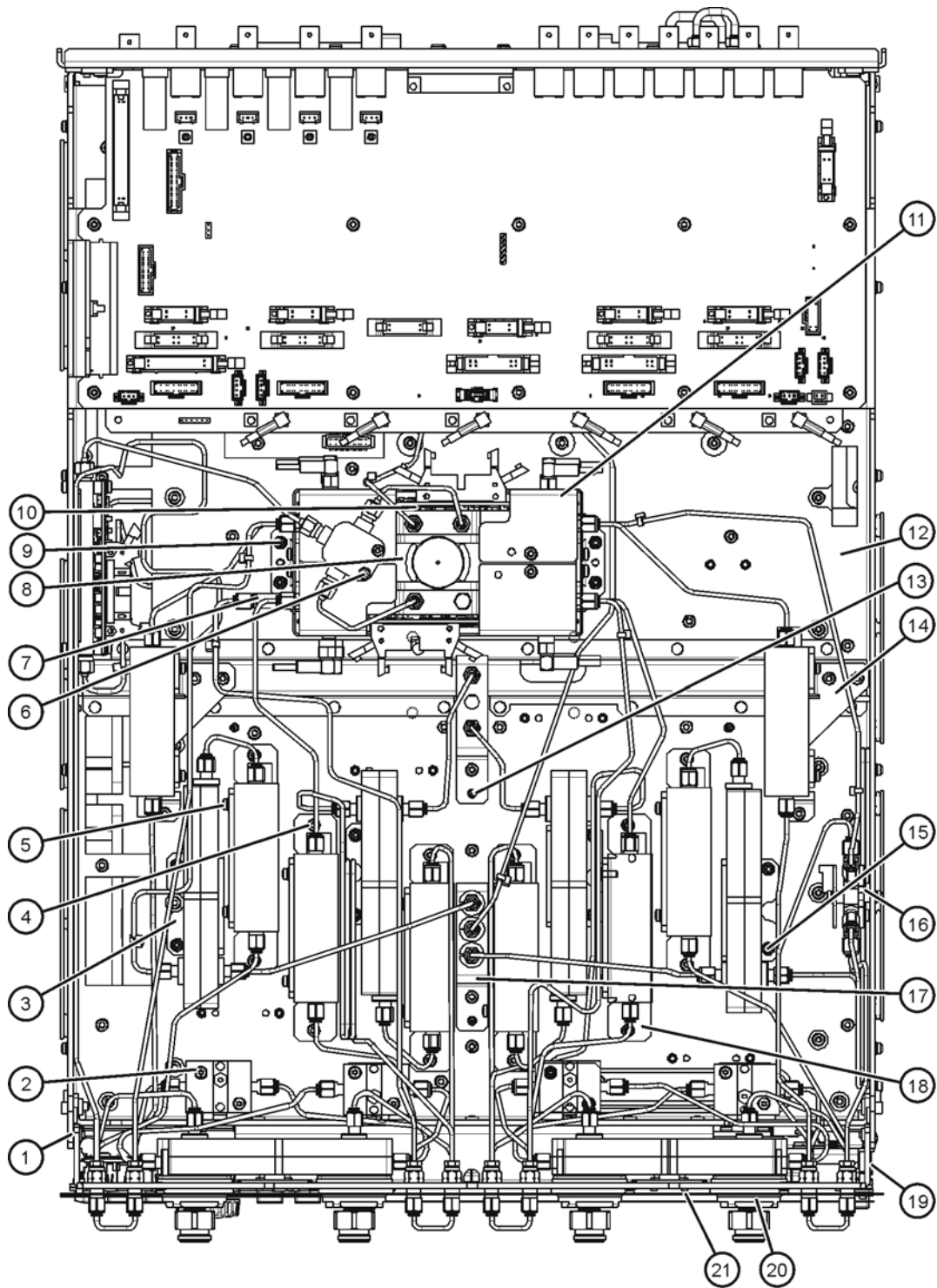

N5225_001_638

Internal Hardware and Miscellaneous Parts, All Options

Reference Designator	Part Number	Qty	Description
①	N5247-00016	1	Left side inner bracket
②	W1312-00048	1	Midplane bracket
③	N5247-00015	1	Right side inner bracket
④	N5224-00001	1	Chassis
⑤	0515-0372	--	Machine screw, M3.0 x 8, pan head (To attach: midplane bracket to left and right side inner brackets, front bracket to left and right side inner brackets, chassis to left and right side inner brackets, midplane bracket, and front bracket.)
⑥	N5247-00013	1	Front bracket
⑦	N5242-40002	24	PC board guides

Figure 6-44 Internal Hardware and Miscellaneous Parts, All Options

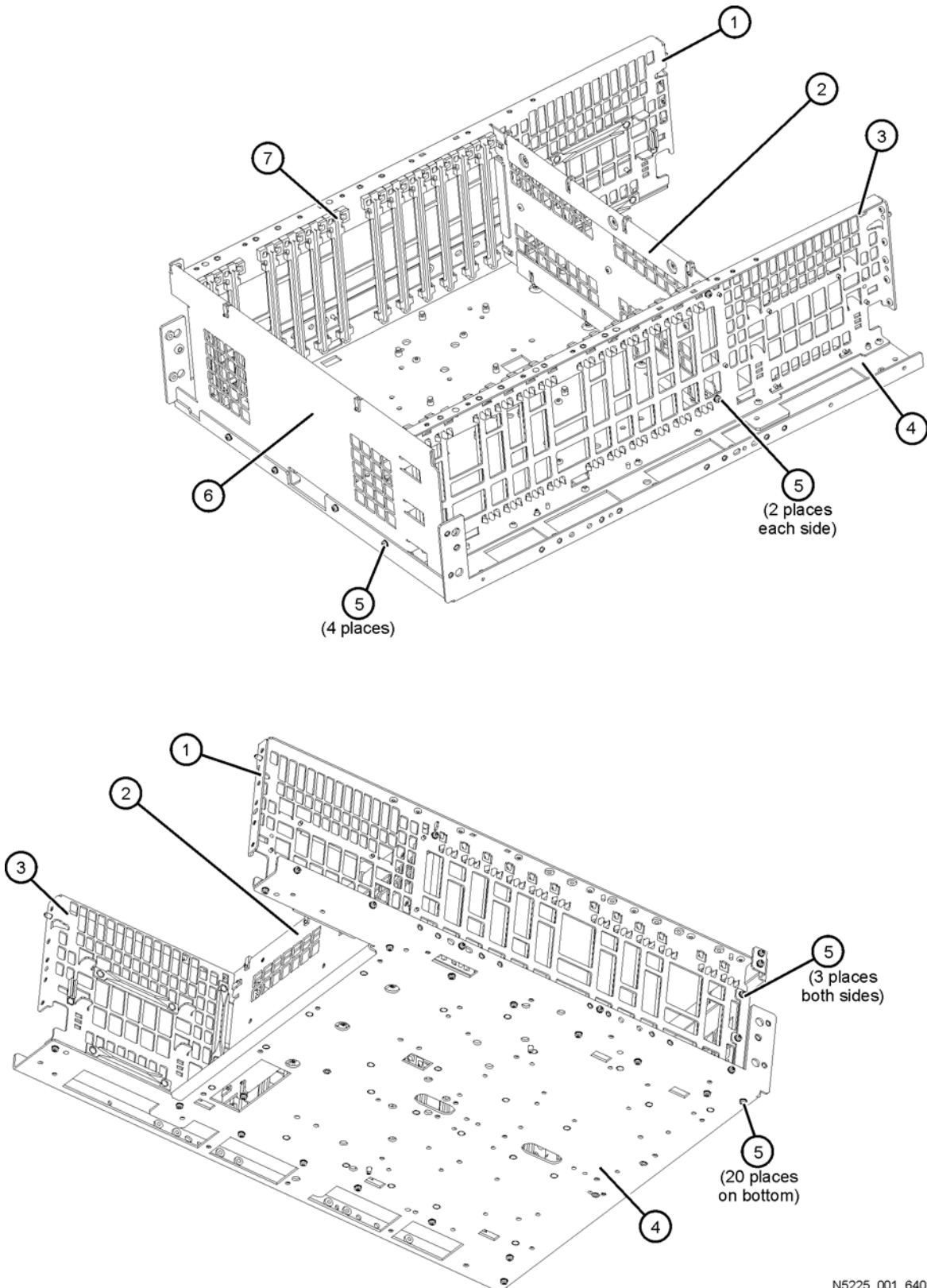

N5225_001_640

External Hardware and Miscellaneous Parts, All Options

Reference Designator	Part Number	Qty	Description
①	N5245-00018	1	Outer cover
②	5041-9611	4	Rear foot
③	0515-1619	--	Machine screw M4.0 x 25, pan head (To attach rear foot.)
④	N5247-60003	2	Strap handle assembly (Includes item ⑤.)
⑤	0515-0710	--	Machine screw M5.0 x 18, flat head (To attach strap handles.)
⑥	5021-2840	4	Key lock (for bottom foot)
⑦	5041-9167	4	Bottom foot
	W1312-40032	4	Hole plug (When analyzer is rack mounted.)
⑧	0515-0372	--	Machine screw, M3.0 x 8, pan head (To attach inner cover.)
⑨	N5247-00004	1	Inner cover (retaining shield)
⑩	0515-1227	--	Machine screw, M3.0 x 6, flat head (To attach inner cover.)
Not shown	N5245-40001	1	Front impact cover
Not shown	N5245-40002	1	Rear impact cover

Figure 6-45 External Hardware and Miscellaneous Parts, All Options

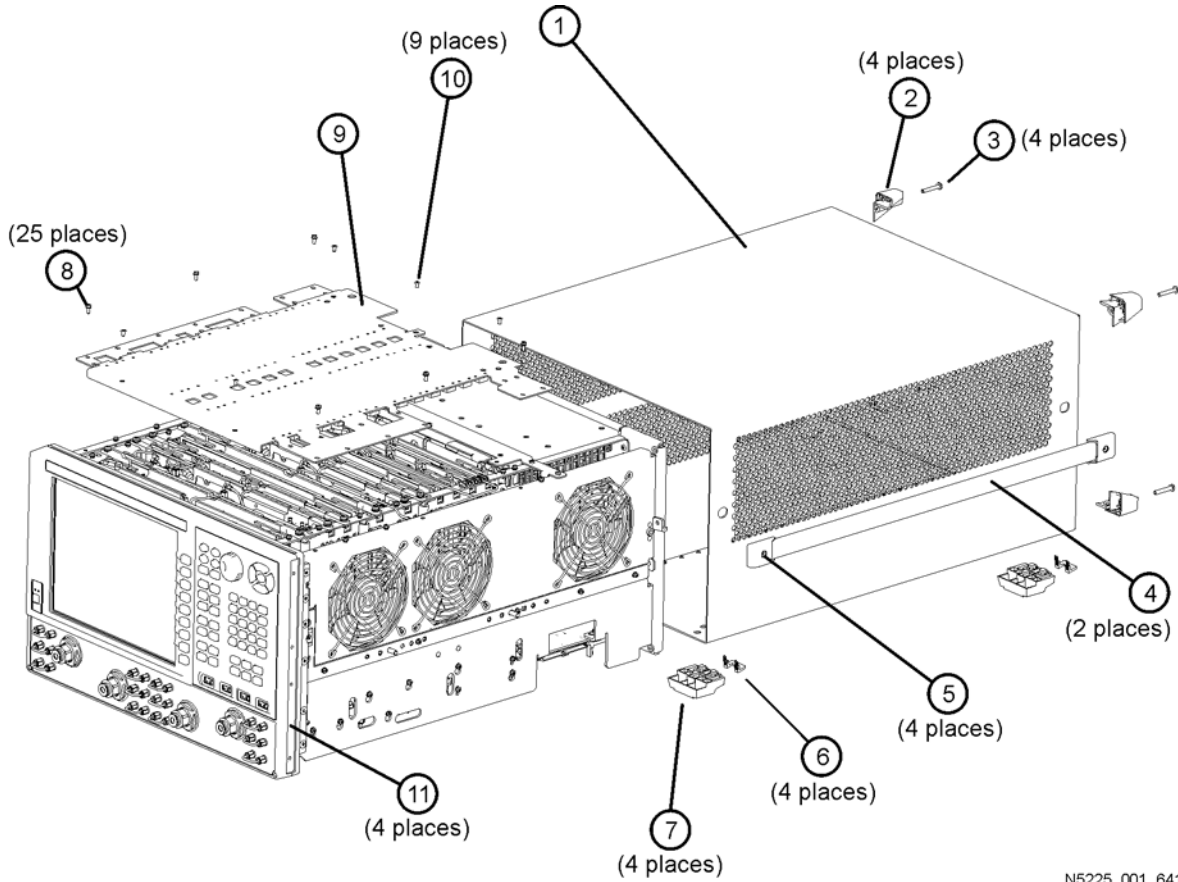

N5225_001_641

Miscellaneous Part Numbers

Table 6-3 Part Numbers for Miscellaneous Parts and Accessories

Description	Model or Part Number
Service Tools	
1/4 inch and 5/16 inch open-end wrench, thin profile	8710-0510
5/16 inch (8 mm), open-end wrench	8710-2174
1/2 inch to 9/16 inch (8 mm), open-end wrench	8710-1770
20 mm open-end torque wrench; 0.9 N-m (8 in-lb)	8710-1764
Spanner wrench	08513-20014
Documentation	
Installation and Quick Start Guide (for all PNA series analyzers) (Cannot be ordered. Part number is for reference only. Must be printed from the Keysight Web site. Refer to "Printing Copies of Documentation from the Web" on page iii.)	E8356-90001
Service Guide. (Not available in printed form. Part number is for reference only. Must be printed from the Keysight Web site. Refer to "Printing Copies of Documentation from the Web" on page iii.)	N5225-90001
GPIB Cables/GPIB Adapter	
GPIB cable, 0.5 meter (1.6 feet)	10833D
GPIB cable, 1 meter (3.3 feet)	10833A
GPIB cable, 2 meter (6.6 feet)	10833B
GPIB cable, 4 meter (13.2 feet)	10833C
GPIB cable to GPIB cable adapter	10834A
Protective Covers for Connectors	
Cap, protective, 0.812-ID	1401-0214
Cap, protective, 0.625-ID	1401-0225
Cap, protective, 1/4 - 36 threads	5188-5406
Protective guard for outer two sets of front panel jumpers	N5242-00029
Protective guard for center two sets of front panel jumpers	N5242-00030
Fuses	
Rear Panel Bias Input Fuse; Ports 1, 2, 3, and 4 (0.5 A, 125 V)	2110-0824 Was 2110-0046
Battery	
Battery, lithium manganese dioxide, 3V, 0.22A-hr. (located on A21 CPU board assembly)	1420-0356

Table 6-3 Part Numbers for Miscellaneous Parts and Accessories (Continued)

Description	Model or Part Number
Analyzer Accessories	
Pulse I/O Adapter (For connecting between the analyzer's rear-panel PULSE I/O connector and the coaxial inputs and outputs of external pulse generators and external pulse modulators.)	N1966A
USB Accessories	
Mouse	1150-7799
Keyboard (U.S. style)	1150-7896
USB to GPIB adapter	82357B
ESD Supplies	
Adjustable antistatic wrist strap	9300-1367
Antistatic wrist strap grounding cord (5 foot length)	9300-0980
Static control table mat and earth ground wire	9300-0797
ESD heel strap	9300-1308
Upgrade Kits	
See "Analyzer Options, Accessories, and Upgrades Available" on page 2-4 for a complete list of upgrades orderable by model number.	
Rack Mount Kits and Handle Kits	
Rack mount kit for analyzers without handles (Option 1CM)	N5231AU-1CM or N5232AU-1CM or N5239AU-1CM
<i>Option 1CM includes the following separately orderable items:</i>	
<i>Rack mount kit (rack mount flanges and hardware)</i>	1CM042A Was 5063-9217
<i>Rack mount rail set</i>	E3663AC
Rack mount kit for analyzers with handles (Option 1CP)	N5231AU-1CP or N5232AU-1CP or N5239AU-1CP
<i>Option 1CP includes the following separately orderable items:</i>	
<i>Rack mount kit (rack mount flanges and hardware)</i>	5063-9237
<i>Rack mount rail set</i>	E3663AC
<i>Front handle kit (two classic^a handles and hardware)</i>	5063-9230
Touch-up Paint	
Dove gray (for use on frame around front panel and painted portion of handles)	6010-1146
French gray (for use on cover)	6010-1147
Parchment white (for use on rack mount flanges, rack support flanges, and front panels)	6010-1148

a. For rack mount use, you must replace factory installed ruggedized handles (thick aluminum, no trim) with classic handles (thin aluminum with plastic trim), included with Option 1CP.

7 Repair and Replacement Procedures

Information in This Chapter

This chapter contains procedures for removing and replacing the major assemblies of your Keysight Technologies PNA series microwave network analyzer.

Chapter Seven at-a-Glance

Section Title	Summary of Content	Start Page
Personal Safety Warnings	Warnings and cautions pertaining to personal safety.	Page 7-3
Electrostatic Discharge (ESD) Protection	Information pertaining to ESD protection.	Page 7-3
Table of Removal and Replacement Procedures	A table of removal and replacement procedures and the corresponding page number where they are located.	Page 7-4
Removal and Replacement Procedures	The actual procedures for removing and replacing the major assemblies in your analyzer. <i>The procedures occur in assembly reference designator numerical order.</i>	See Table 7-1 on page 7-4 for specific procedures.
Post-Repair Procedures	A table for the proper tests, verifications, and adjustments to perform on your analyzer after repair.	Page 7-56

CAUTION The PNA contains extremely sensitive components that can be ruined if mishandled. Follow instructions carefully when making cable connections, especially wire harness connections.

The person performing the work accepts responsibility for the full cost of the repair or replacement of damaged components.

Personal Safety Warnings

WARNING These servicing instructions are for use by qualified personnel only. To avoid electrical shock, do not perform any servicing unless you are qualified to do so.

WARNING The opening of covers or removal of parts is likely to expose dangerous voltages. Disconnect the analyzer from all voltage sources while it is being opened.

WARNING Procedures described in this document may be performed with power supplied to the product while protective covers are removed. Energy available at many points may, if contacted, result in personal injury.

WARNING The power cord is connected to internal capacitors that may remain live for 10 seconds after disconnecting the plug from its power supply assembly. Wait at least 10 seconds, after disconnecting the plug, before removing the covers.

WARNING The detachable power cord is the instrument disconnecting device. It disconnects the mains circuits from the mains supply before other parts of the instrument. The front panel switch is only a standby switch and is not a LINE switch (disconnecting device).

WARNING Danger of explosion if battery is incorrectly replaced. Replace only with the same or equivalent type recommended. Discard used batteries according to manufacturer's instructions.

Electrostatic Discharge (ESD) Protection

CAUTION Many of the assemblies in this instrument are very susceptible to damage from electrostatic discharge (ESD). Perform the following procedures only at a static-safe workstation and wear a grounded wrist strap.

This is important. If not properly protected against, electrostatic discharge can seriously damage your analyzer, resulting in costly repair.

To reduce the chance of electrostatic discharge, follow all of the recommendations outlined in ["Electrostatic Discharge Protection"](#) on page 1-6, for all of the procedures in this chapter.

Removal and Replacement Procedures

Table 7-1 List of Procedures

Reference Designator	Assembly Description	Location
N/A	Covers, outer and inner	Page 7-6
N/A	Fan bracket and fans	Page 7-52
N/A	Front panel assembly	Page 7-8
N/A	Front panel LED boards	Page 7-50
A1 A2 A3	Front panel display board USB board Display assembly	Page 7-10
A4, A17, A15 A5, A10 A7, A8 A12, A13 A14 A16	13.5 GHz synthesizer boards 26.5 GHz source boards Doubler boards Frequency reference board Signal processing ADC module (SPAM) board	Page 7-14
A18	System motherboard	Page 7-16
A19	Midplane board	Page 7-18
A20	Power supply	Page 7-20
A21	CPU board	Page 7-22
A22	GPIB board	Page 7-24
A23	Test set motherboard	Page 7-26
A24	IF multiplexer board	Page 7-28
A25	Multiplier/amplifier 26.5 (HMA26.5)	Page 7-30
A26	Splitter	Page 7-32
A27, A28	Mixer bricks	Page 7-34
A29 A30 A31 A32	Port 1 receiver coupler Port 3 receiver coupler Port 4 receiver coupler Port 2 receiver coupler	Page 7-36

Table 7-1 List of Procedures (Continued)

Reference Designator	Assembly Description	Location
A33 A34 A35 A36	Port 1 test port coupler Port 3 test port coupler Port 4 test port coupler Port 2 test port coupler	Page 7-38
A37	Reference mixer switch	Page 7-40
A38 A39 A40 A41	Port 1 source step attenuator Port 3 source step attenuator Port 4 source step attenuator Port 2 source step attenuator	Page 7-42
A42 A43 A44 A45	Port 1 bias tee Port 3 bias tee Port 4 bias tee Port 2 bias tee	Page 7-44
A46 A47 A48 A49	Port 1 receiver step attenuator Port 3 receiver step attenuator Port 4 receiver step attenuator Port 2 receiver step attenuator	Page 7-42
A55	Solid State drive (SSD)	Page 7-46

Removing the Covers

Tools Required

- T-10 TORX driver (torque to 9 in-lb or 1.02 N.m)
- T-20 TORX driver (torque to 21 in-lb or 2.38 N.m)

Removing the Outer Cover

CAUTION This procedure is best performed with the analyzer resting on its front handles in the vertical position. *Do not place the analyzer on its front panel without the handles.* This will damage the front panel assemblies.

Refer to [Figure 7-1](#). for this procedure.

1. Disconnect the power cord.
2. Remove the strap handles (item ①) by loosening the screws (item ②), with a T-20 TORX driver, on both ends until the handle is free of the analyzer.
3. Remove the foot locks (item ③) from the four bottom feet (item ④) and then remove the four bottom feet from the outer cover.
4. Remove the four rear panel feet (item ⑤) by removing the center screws (item ⑥) with a T-20 TORX driver.
5. Slide the outer cover toward the rear of the analyzer and remove it.

Removing the Inner Cover

Refer to [Figure 7-1](#). for this procedure.

1. With a T-10 TORX driver, remove the 24 pan head screws (item ⑦).
2. With a T-10 TORX driver, remove the 9 flat head screws (item ⑧).
3. Lift off the cover.

Replacement Procedure

1. On the top side of the PNA, carefully position the grey flex cables so they can't be pinched between the covers and the rails.
2. On the bottom side of the PNA, carefully fold or push down the ribbon cables and wires so they can't be pinched between the hardware and the outer cover. Ribbon cables and wires must never be positioned on top of hardware.
3. Reverse the order of the removal procedures above.

Figure 7-1. Outer and Inner Cover Removal

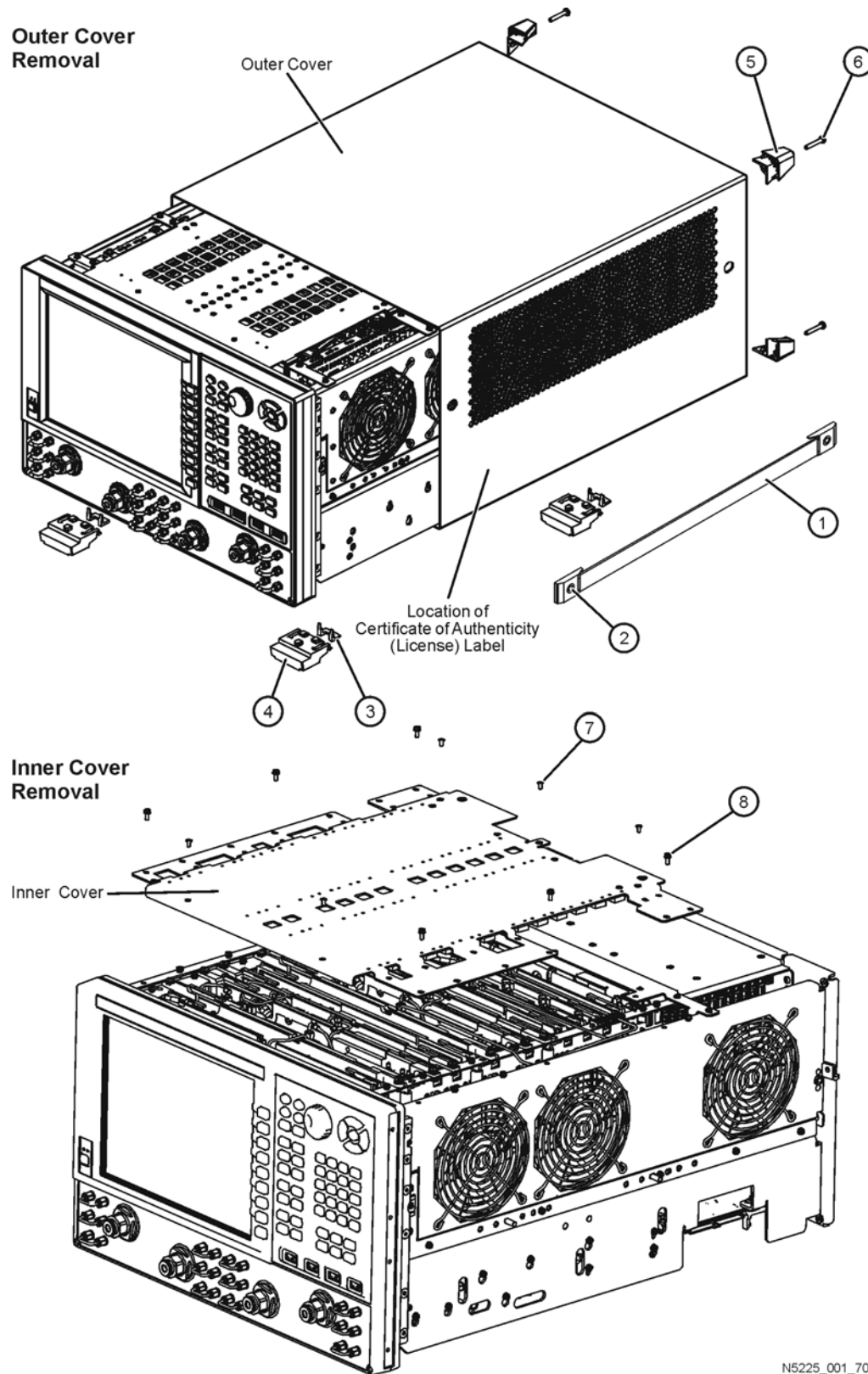

N5225_001_701

Removing and Replacing the Front Panel Assembly

Tools Required

- 9 mm nutsetter or open end wrench torque wrench (torque to 21 in-lb or 2.38 N.m)
- T-10 TORX driver (torque to 9 in-lb or 1.02 N.m)
- T-20 TORX driver (torque to 21 in-lb or 2.38 N.m)
- 5/16 inch open-end torque wrench (torque to 10 in-lb or 1.13 N.m)
- ESD grounding wrist strap

Removal Procedure

Refer to [Figure 7-2](#) for this procedure.

1. Disconnect the power cord.
2. Remove the outer cover. Refer to [“Removing the Covers” on page 7-6](#).
3. With a 5/16 inch torque wrench, remove all the semirigid jumpers (item ①) from the front panel (if present).
4. Remove screws (item ②) from the lower front panel. There are two screws for 2-port models and four screws for 4-port models.
5. With a T-20 TORX driver, remove the 12 screws (item ③) from the sides of the frame.

CAUTION Before removing the front panel from the analyzer, lift and support the front of the analyzer frame.

6. Slide the front panel over the front-panel connectors.
7. Disconnect the ribbon cable (item ④) from the A1 front panel interface board.

Replacement Procedure

IMPORTANT When reconnecting the front-panel jumpers, torque the connectors to 10 in-lb.

1. Reverse the order of the removal procedure.
2. Perform the post-repair adjustments, verifications, and performance tests that pertain to this removal procedure. Refer to [Table 7-2 on page 7-56](#).

Figure 7-2 Front Panel Assembly Removal

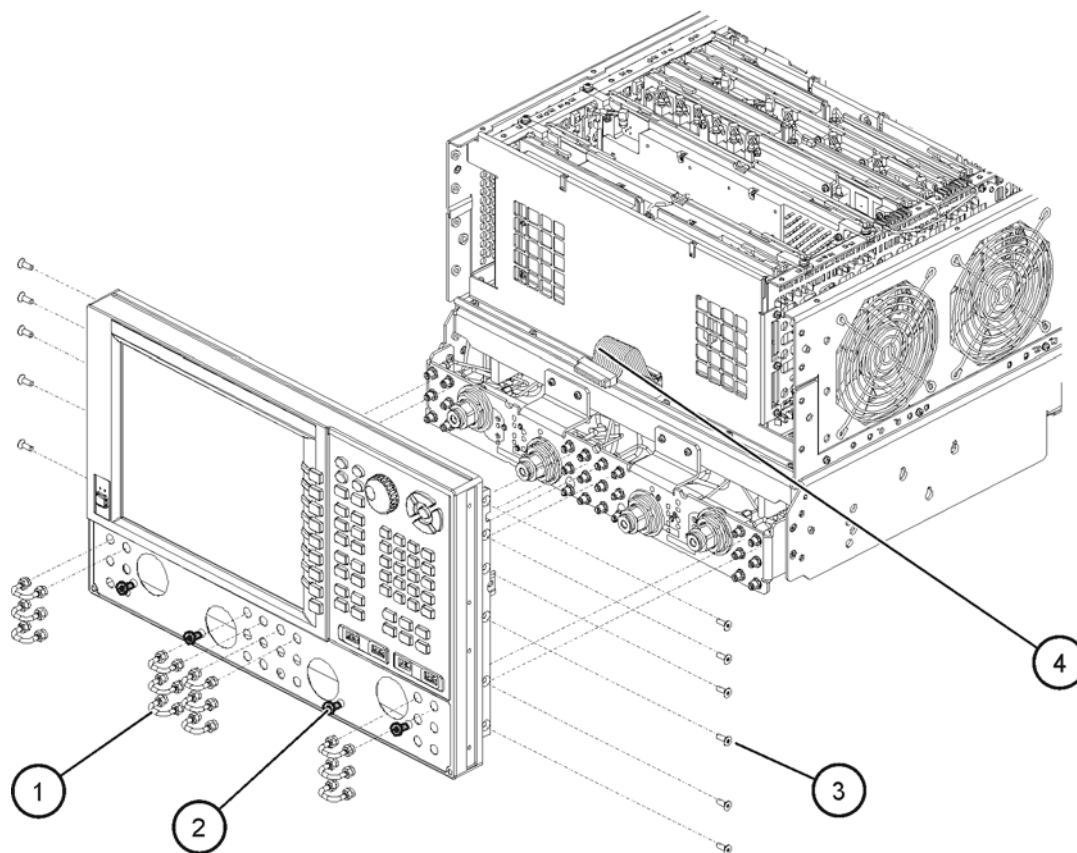

N5225_001_702

Removing and Replacing the A1–A3 and Other Front Panel Subassemblies

Tools Required

- T-8 TORX driver (torque to 6 in-lb or 0.68 N.m)
- T-10 TORX driver (torque to 9 in-lb or 1.02 N.m)
- T-20 TORX driver (torque to 21 in-lb or 2.38 N.m)
- 5/16 inch open-end torque wrench (torque to 10 in-lb or 1.13 N.m)
- ESD grounding wrist strap

Refer to [Figure 7-3](#), [Figure 7-4](#), and [Figure 7-5](#) for the following procedures.

Pre-removal Procedure

1. Disconnect the power cord.
2. Remove the front panel assembly. Refer to [“Removing and Replacing the Front Panel Assembly”](#) on page 7-8.

Removing the A2 USB Board

1. Remove the four retaining screws (item ①) from the USB board and unplug it from the A1 front panel interface board.

Removing the A1 Front Panel Interface Board and Keypad Assembly

1. Remove the round knob (RPG) from the front panel by gently pulling the knob forward.
2. Remove the A2 USB board as outlined above.
3. Disconnect the following cables from the A1 front panel interface board: display cable (item ②), inverter board cable (item ③), touchscreen controller board cable (item ④), and power switch cable (item ⑤).
4. Remove the seven screws (item ⑥) from the A3 display assembly and remove it from the front panel assembly.
5. Remove the eight screws (item ⑦) from the A1 front panel interface board and remove it from the front panel assembly.
6. The keypad assembly can now be removed from the A1 front panel interface board by gently pulling each of the rubber tabs through the PC board.

Removing the Inverter Board

1. Disconnect the inverter board cable (item ③) and the LCD cable (item ⑧) from the inverter board.
2. Remove two screws (item ⑨) and remove the inverter board.

Removing the Touchscreen Controller Board

1. Disconnect the touchscreen controller board cable (item ④) from the touchscreen controller board and front panel interface board.
2. Disconnect the flat flex cable from the touchscreen.
3. Remove two screws (item ⑩) and remove the touchscreen controller board.

Removing the Power Switch Board and Power Button Keypad

1. Disconnect the power switch cable (item ⑤) from the power switch board.
2. Remove two screws (item ⑪) and remove the power switch board.
3. The power button keypad can now be removed from the power switch board by gently pulling each of the rubber tabs through the PC board.

Figure 7-3 Front Panel Subassemblies Removal

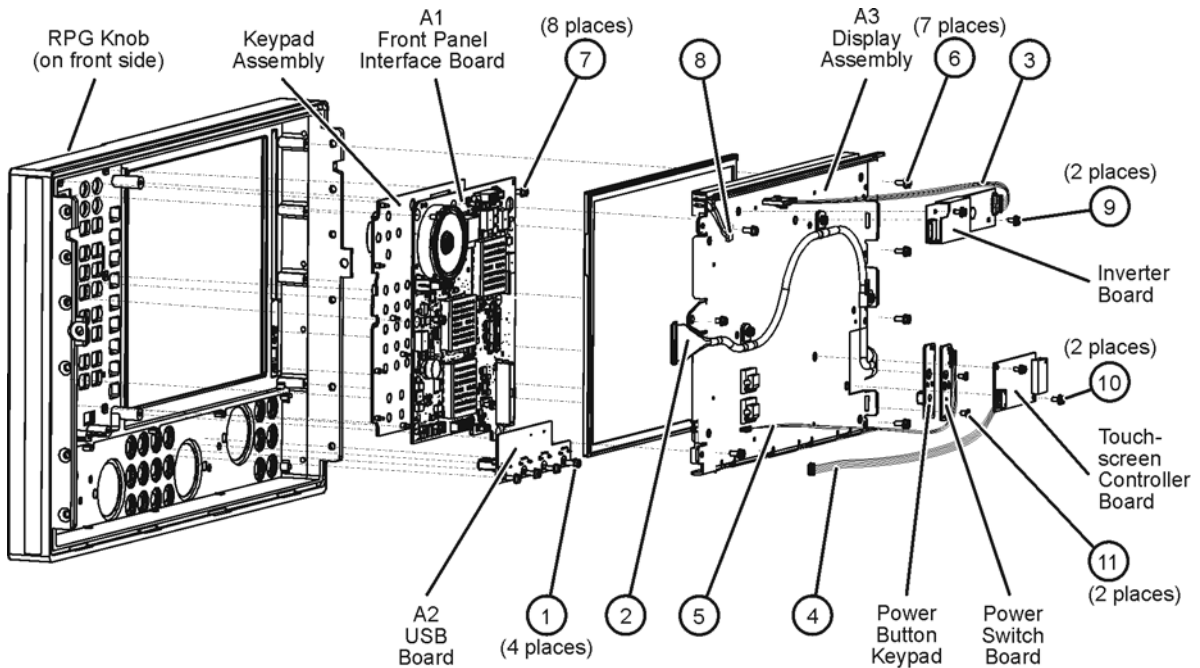

N5225_001_703

Removing the A3 Display Assembly and the Touchscreen

1. Disconnect the following cables from the A1 front panel interface board: display cable (item ①), inverter board cable (item ②), touchscreen controller board cable (item ③), and power switch cable (item ④).
2. Remove seven screws (item ⑤) from the A3 display assembly and remove the A3 display assembly from the front panel assembly.
3. The touch screen can now be removed from the front panel assembly. Note the orientation of the touch screen in the front panel assembly for installation of the new touch screen.

To replace the touch screen, note the orientation of the rubber boot on the old touch screen and then remove it and install it on the new one in the same orientation.

Figure 7-4 A3 Display Assembly and Touch Screen Removal-1

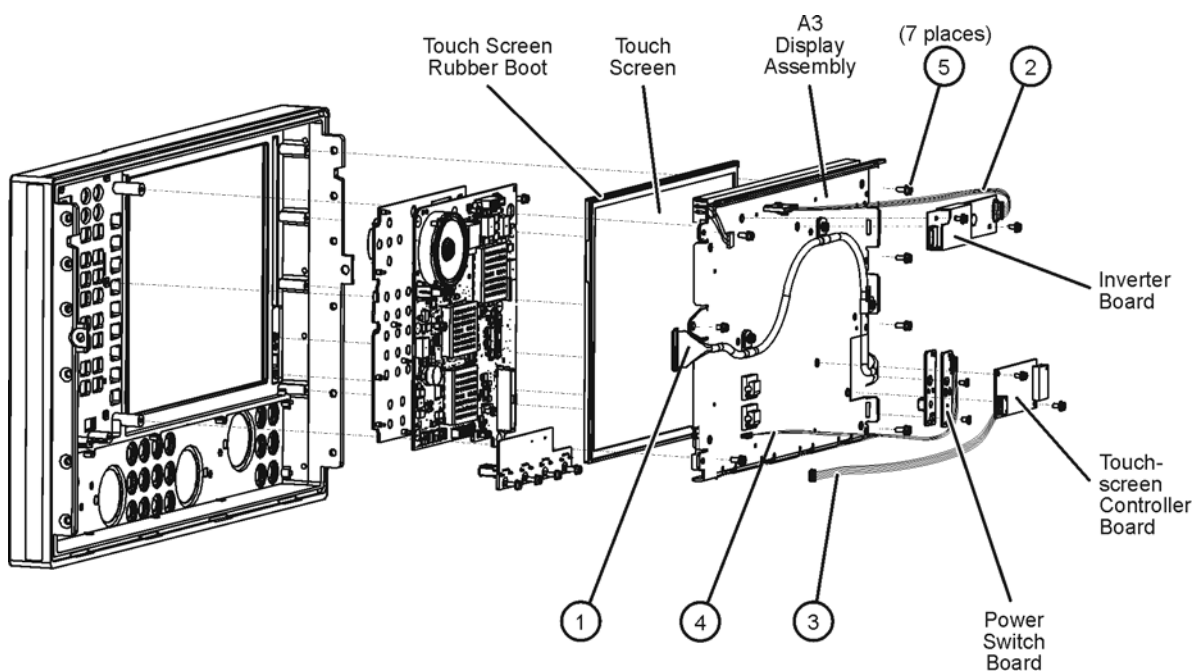

N5225_001_704

4. The display cable (item ⑥) can be removed by removing the three screws (item ⑦) that attach it to the LCD display hold down bracket (item ⑧).
5. The LCD display can be removed by disconnecting the LCD cable from the inverter board and then removing the four screws (item ⑨) that attach it to the LCD display hold down bracket (item ⑧). Note the location of the four spacers (item ⑩) before separating the LCD display from the hold down bracket.

Figure 7-5 A3 Display Assembly and Touch Screen Removal-2

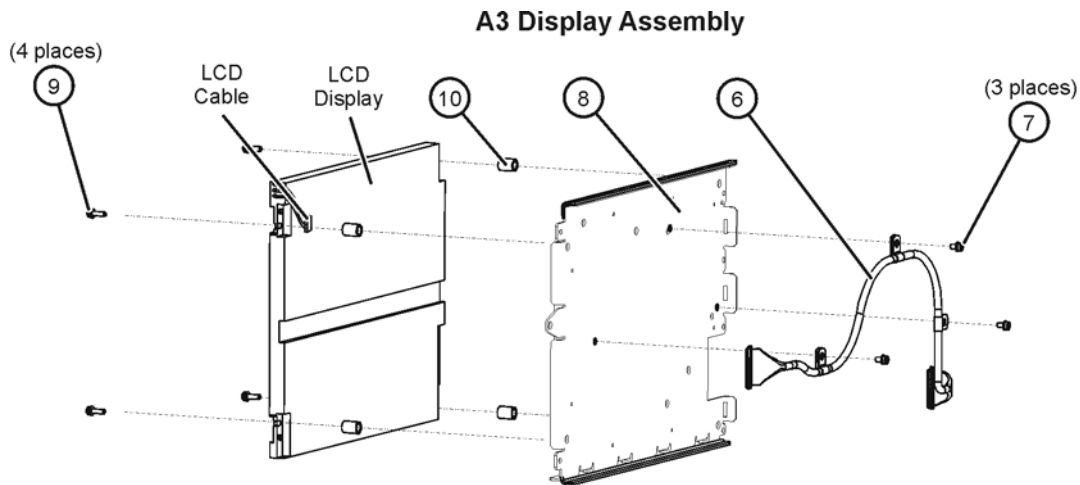

N5225_001_705

Replacement Procedure

1. Reverse the order of the removal procedure.
2. Perform the post-repair adjustments, verifications, and performance tests that pertain to this removal procedure. Refer to [Table 7-2 on page 7-56](#).

Removing and Replacing the A4–A17 Boards

Tools Required

- T-10 TORX driver (torque to 9 in-lb or 1.02 N.m)
- T-20 TORX driver (torque to 21 in-lb or 2.38 N.m)
- 5/16 inch open-end torque wrench (torque to 10 in-lb or 1.13 N.m)
- 9 mm socket or open-end wrench (torque to 21 in-lb or 2.38 N.m)
- ESD grounding wrist strap

Removal Procedure

Refer to [Figure 7-6](#) for this procedure.

NOTE Any cables that are removed should be labeled for reinstallation later.

1. Disconnect the power cord.
2. Remove the outer and inner covers. Refer to [“Removing the Covers” on page 7-6](#).
3. A5 and A10 source boards:
 - a. A10 source board only: on the top side of the analyzer, disconnect all visible semirigid cables from the A10, A12, and A13 boards (item ①).
 - b. A5 source board only: on the top side of the analyzer, disconnect all visible semirigid cables from the A4, A7, and A8 boards.
 - c. On the top side of the analyzer, remove two screws (item ②), one at each end of the board, from the source board to be removed.
 - d. Lift the two extractors (item ③), one at each end of the board. Adjust the slack in the gray flexible cable to move it out of the way, and lift the board out of the chassis.
4. A7, A8, A12, A13 boards: on the bottom side of the analyzer, disconnect cables (item ①) from the cable brackets.
5. A4, A7, A8, A12, A13, A14, A15, A16, and A17 boards:
 - a. Remove all cables connected to the top of the board to be removed. Note the location of each cable for reinstallation.
 - b. Remove two screws (item ②), one at each end of the board, from the board to be removed (Exception: A14 does not have screws).
 - c. Lift the two extractors (item ③), one at each end of the board, and lift the board.
 - d. Before removing the board, check the bottom of the board for any attached cables.

Replacement Procedure

1. Reverse the order of the removal procedure.

Remember to connect any necessary cables to the bottom of the board before reinstalling it. If replacing a doubler board, make sure the new board has loads connected to the same ports as were used on the old board. This may require moving a load from the old board to the new board or removing the load from the new board.

When replacing the A5 or A10 source board, remove the semirigid cables attached to the bottom of the old board and attach them to the bottom of the new board. Be sure to orient these cables the same as they were on the old board.
2. Perform the post-repair adjustments, verifications, and performance tests that pertain to this removal procedure. Refer to [Table 7-2 on page 7-56](#).

NOTE The A4, A15, and A17 synthesizer boards will not perform correctly and will cause the PNA to display errors until the Synthesizer Bandwidth Adjustment and the EE Default Adjustment are completed, as per [Table 7-2 on page 7-56](#).

Figure 7-6 A4, A5, A7, A8, A10, A12, A13, A14, A15, A16, and A17 Boards Removal

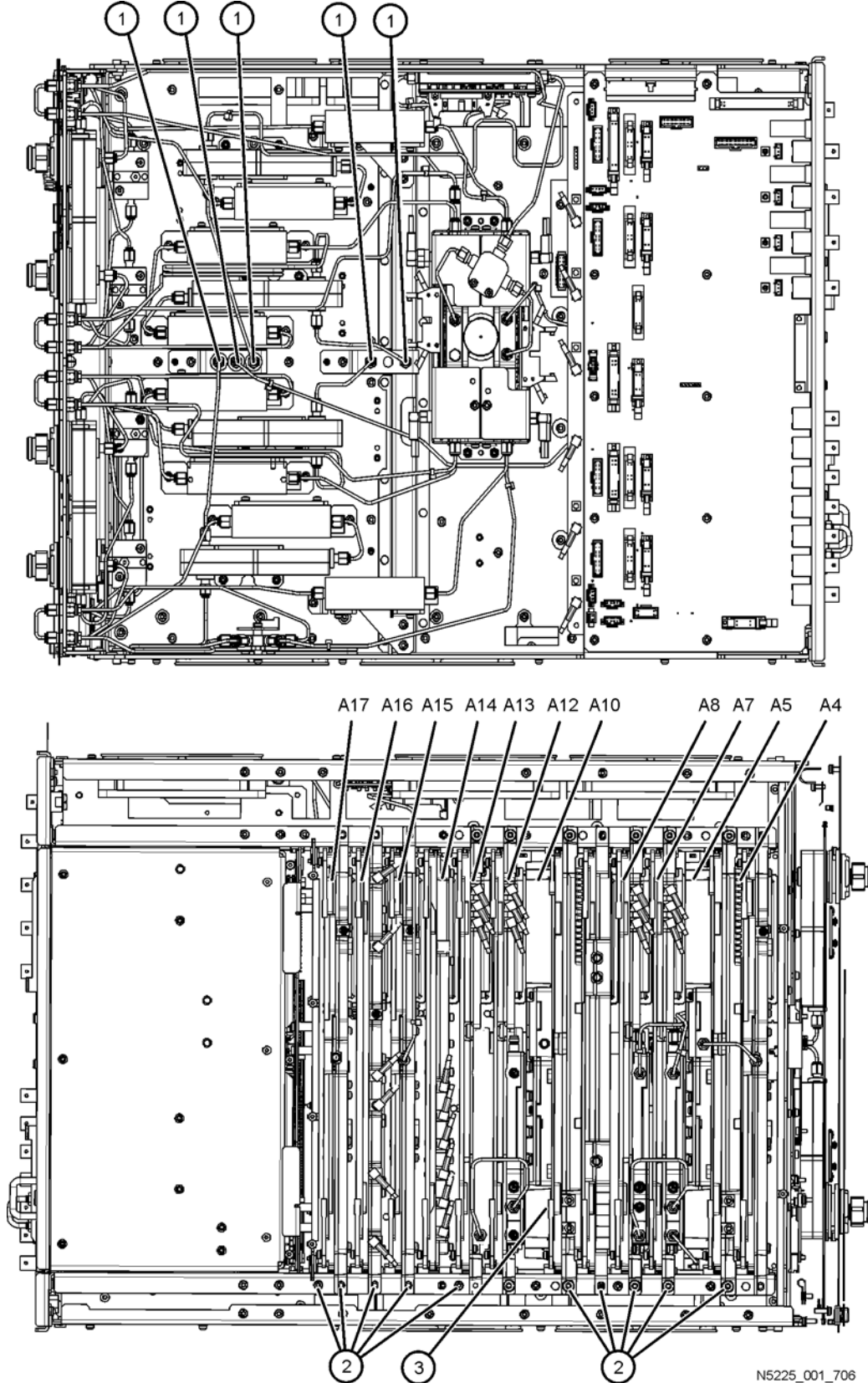

N5225_001_706

Removing and Replacing the A18 System Motherboard

Tools Required

- T-10 TORX driver (torque to 9 in-lb or 1.02 N.m)
- T-20 TORX driver (torque to 21 in-lb or 2.38 N.m)
- 5/16 inch open-end torque wrench (torque to 10 in-lb or 1.13 N.m)
- 5/8 inch nutsetter (torque to 21 in-lb or 2.38 N.m)
- ESD grounding wrist strap

Removal Procedure

Refer to [Figure 6-6 on page 6-18](#) and [Figure 6-21 on page 6-49](#) for this procedure.

1. Disconnect the power cord.
2. Remove the outer and inner covers. Refer to [“Removing the Covers” on page 7-6](#).
3. Remove the front panel assembly. Refer to [“Removing and Replacing the Front Panel Assembly” on page 7-8](#).
4. Remove the A20 power supply. Refer to [“Removing and Replacing the A20 Power Supply Assembly” on page 7-20](#).
5. Remove the A21 CPU. Refer to [“Removing and Replacing the A21 CPU Board Assembly” on page 7-22](#).
6. Disconnect the rear panel cables.
7. Remove the threaded hardware from the rear panel.
8. Remove the rear panel.
9. Remove the A22 GPIB board. Refer to [“Removing and Replacing the A22 GPIB Board” on page 7-24](#).
10. Remove the A19 midplane board. Refer to [“Removing and Replacing the A19 Midplane Board” on page 7-18](#).
11. Remove the A4–A17 boards. Refer to [“Removing and Replacing the A4–A17 Boards” on page 7-14](#).
12. Remove the right side and left side fan brackets. Disconnect the right fan wire and the left fan wire from the A18 System Motherboard, and then remove the fan brackets. Refer to [“Removing and Replacing the Fans” on page 7-52](#).
13. Turn the analyzer over so that the bottom side is up and remove the A23 Test Set Motherboard and the A24 IF Mux. Disconnect the two ribbon cables from the A18 System Motherboard.
14. Remove four screws (item ①) that secure the bottom of the midplane bracket to the chassis.
15. Remove seven screws (item ②) that secure the left side inner bracket to the chassis.
16. Turn the analyzer back over so that the top side is up. Remove two screws (item ③) from each side that secure the midplane bracket to the chassis inner panels. Lift the midplane bracket out of the analyzer.
17. Remove the three screws (item ④) that secure the front bracket to the chassis left inner panel.
18. Remove three screws (item ⑤) that secure the A18 system motherboard to the chassis.
19. Slide the A18 system motherboard toward the rear of the analyzer to release it from the 15 keyhole standoffs (item ⑥) on the chassis.
20. Lift the A18 system motherboard out of the analyzer.

Replacement Procedure

1. Reverse the order of the removal procedure.
2. Perform the post-repair adjustments, verifications, and performance tests that pertain to this removal procedure. Refer to [Table 7-2 on page 7-56](#).

Figure 7-7. A18 System Motherboard Removal

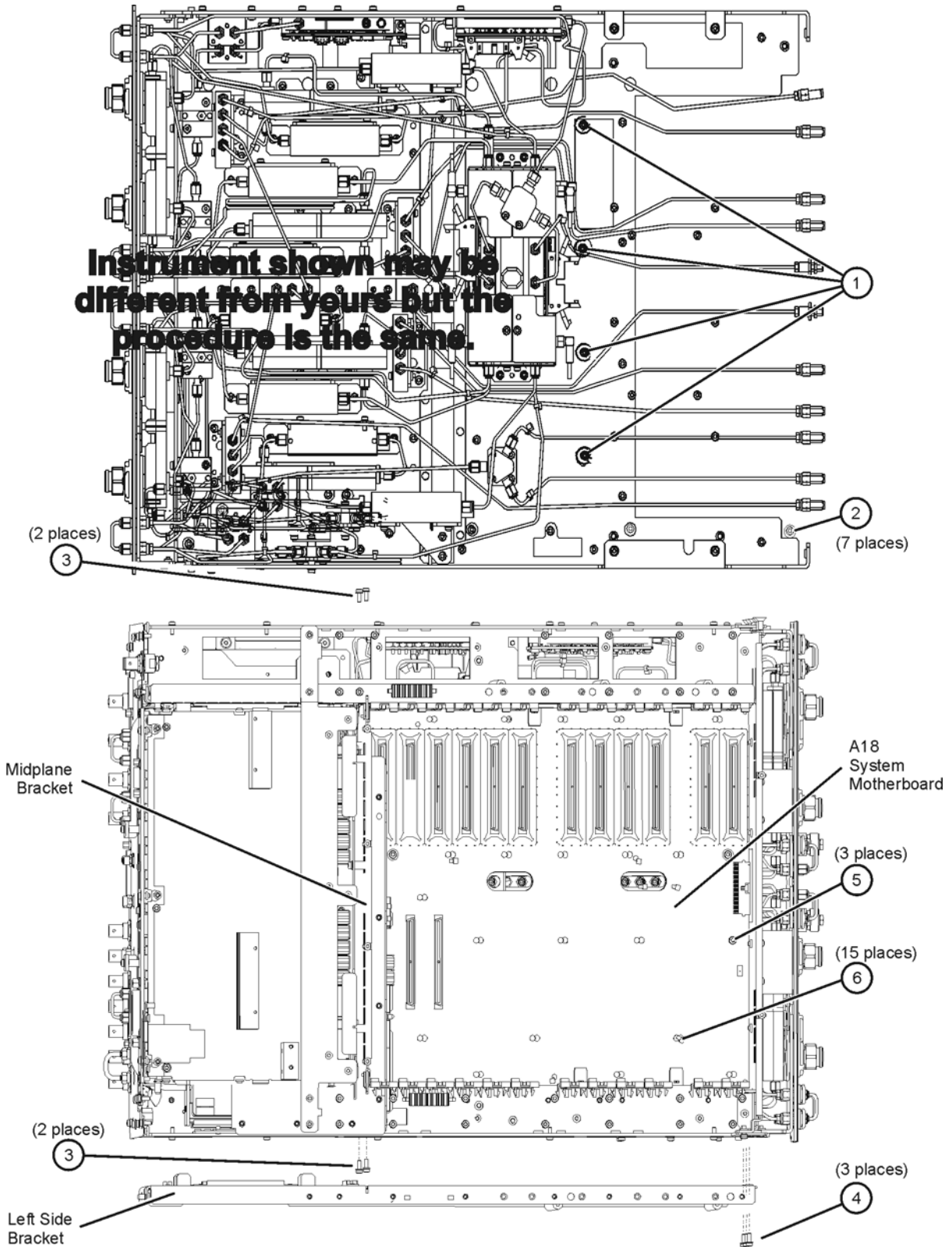

N5225_001_712

Removing and Replacing the A19 Midplane Board

Tools Required

- T-10 TORX driver (torque to 9 in-lb)
- T-20 TORX driver (torque to 21 in-lb)
- 5/16 inch open-end torque wrench (torque to 10 in-lb)
- ESD grounding wrist strap

Removal Procedure

Refer to [Figure 7-8](#) for this procedure.

1. Disconnect the power cord.
2. Remove the outer and inner covers. Refer to [“Removing the Covers”](#) on page 7-6.
3. Remove the A20 power supply assembly. Refer to [“Removing and Replacing the A20 Power Supply Assembly”](#) on page 7-20.
4. Remove the A21 CPU board assembly. Refer to [“Removing and Replacing the A21 CPU Board Assembly”](#) on page 7-22.
5. Remove six screws (item ①) from the A19 midplane board.
6. Lift the board ejectors (item ②) to the upright position to disengage the A19 midplane board from the A18 system motherboard.
7. Note the positions of the six rubber grommets (item ③) on the bottom three A19 midplane board alignment pins. Remove these rubber grommets and retain them for reinstallation on the new A19 midplane board.
8. Lift the A19 midplane board out of the analyzer.

Replacement Procedure

1. Reverse the order of the removal procedure.

Be careful to align the guide pins on the A19 midplane board connectors with the slots on the A18 system motherboard connectors.

The board ejectors should be in the upright position when installing the A19 midplane board. Align these ejectors with the slots in the chassis inner panels as the board is lowered into position and then push them down flat.

Remember to install the six rubber grommets on the bottom three alignment pins.

2. Perform the post-repair adjustments, verifications, and performance tests that pertain to this removal procedure. Refer to [Table 7-2](#) on page 7-56.

Figure 7-8 A19 Midplane Board Removal

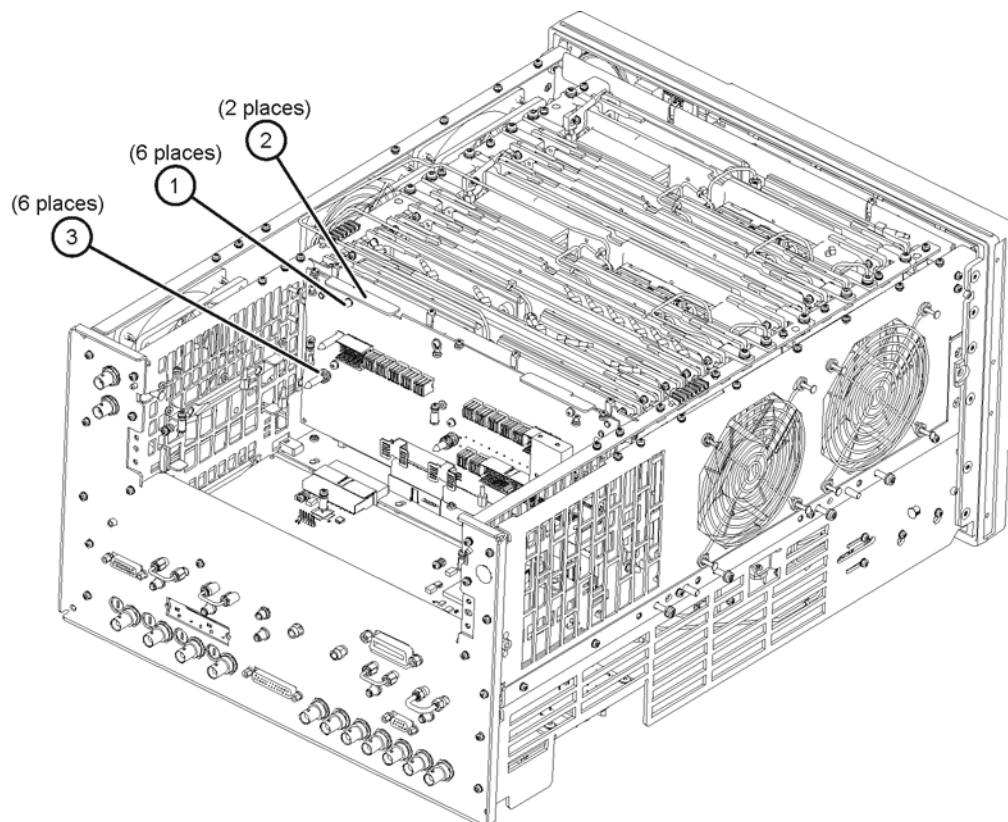

N5225_001_711

Removing and Replacing the A20 Power Supply Assembly

Tools Required

- T-10 TORX driver (torque to 9 in-lb or 1.02 N.m)
- T-20 TORX driver (torque to 21 in-lb or 2.38 N.m)
- ESD grounding wrist strap

Removal Procedure

Refer to [Figure 7-9](#) for this procedure.

1. Disconnect the power cord.
2. Remove the outer and inner covers. Refer to [“Removing the Covers” on page 7-6](#).
3. Remove the three flat head screws (item ①) from the power supply bracket.
4. Remove the seven pan head screws (item ②) from the power supply rear panel.
5. Slide the A20 power supply assembly out the rear of the analyzer.

Replacement Procedure

1. Reverse the order of the removal procedure.
2. Perform the post-repair adjustments, verifications, and performance tests that pertain to this removal procedure. Refer to [Table 7-2 on page 7-56](#).

Figure 7-9 A20 Power Supply Assembly Removal

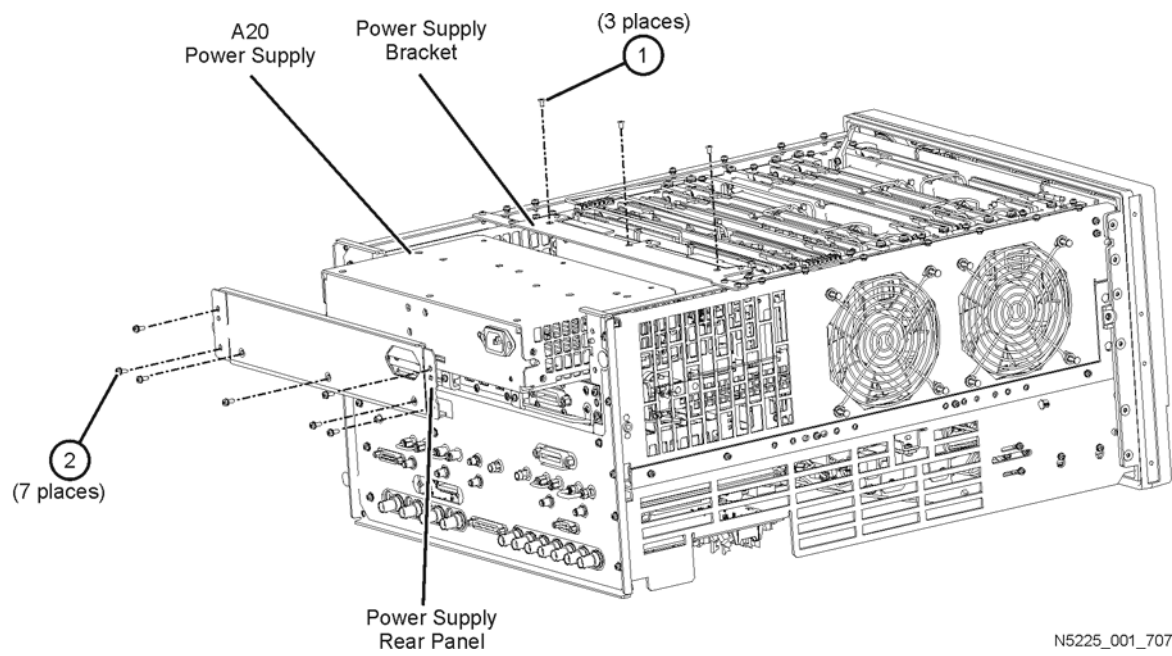

N5225_001_707

Removing and Replacing the A21 CPU Board Assembly

Tools Required

- T-10 TORX driver (torque to 9 in-lb or 1.02 N.m)
- T-20 TORX driver (torque to 21 in-lb or 2.38 N.m)
- ESD grounding wrist strap

Removal Procedure

Refer to [Figure 7-10](#) for this procedure.

1. Disconnect the power cord.
2. It is *not* necessary to remove the instrument cover(s) to remove the A21 CPU board assembly.
3. Remove six screws (item ①) from the A21 CPU board assembly - four from the CPU assembly rear panel and two from the ejector handles.
4. Grasp the two ejector handles and rotate them outward toward the sides of the analyzer as shown in the illustration. This will disengage the A21 CPU board assembly from the A19 midplane board.
5. Slide the A21 CPU board assembly out the rear of the analyzer.
6. If the A21 CPU board assembly is being replaced, you must first remove the A55 solid state drive for reinstallation in the new A21 CPU board assembly. Refer to [“Removing and Replacing the A55 Solid State Drive \(SSD\)”](#) on page 7-46.

Replacement Procedure

1. Reverse the order of the removal procedure.
2. Perform the post-repair adjustments, verifications, and performance tests that pertain to this removal procedure. Refer to [Table 7-2](#) on page 7-56.

Figure 7-10 A21 CPU Board Assembly Removal

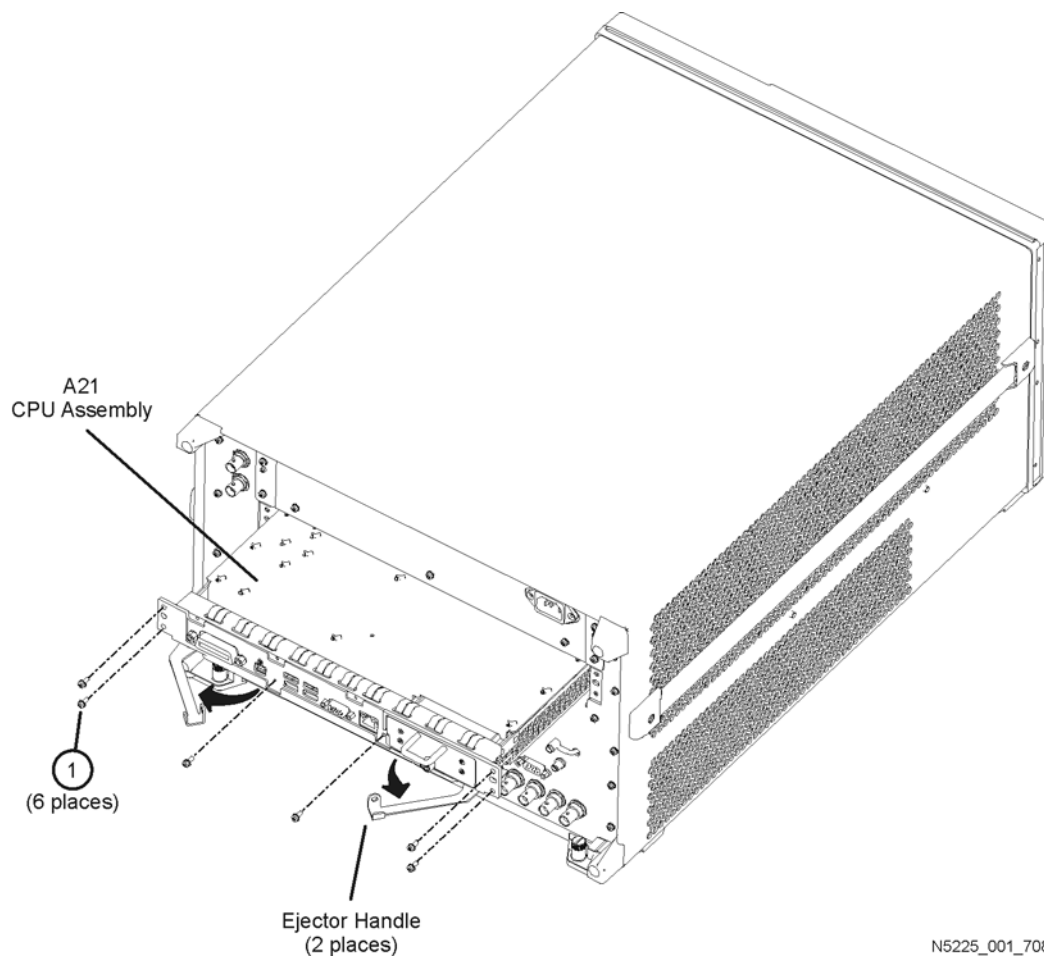

N5225_001_708

Removing and Replacing the A22 GPIB Board

Tools Required

- T-10 TORX driver (torque to 9 in-lb or 1.02 N.m)
- T-20 TORX driver (torque to 21 in-lb or 2.38 N.m)
- ESD grounding wrist strap

Removal Procedure

Refer to [Figure 7-11](#) for this procedure.

1. Disconnect the power cord.
2. Remove the outer and inner covers. Refer to [“Removing the Covers” on page 7-6](#).
3. Remove the A20 power supply assembly. Refer to [“Removing and Replacing the A20 Power Supply Assembly” on page 7-20](#).
4. Remove the A21 CPU board assembly. Refer to [“Removing and Replacing the A21 CPU Board Assembly” on page 7-22](#).
5. Remove the rear panel. Refer to [“Removing and Replacing the Rear Panel” on page 7-48](#).
6. Slide the A22 GPIB board out the rear of the analyzer.

Replacement Procedure

1. Reverse the order of the removal procedure.
2. Perform the post-repair adjustments, verifications, and performance tests that pertain to this removal procedure. Refer to [Table 7-2 on page 7-56](#).

Figure 7-11 A22 GPIB Board Removal

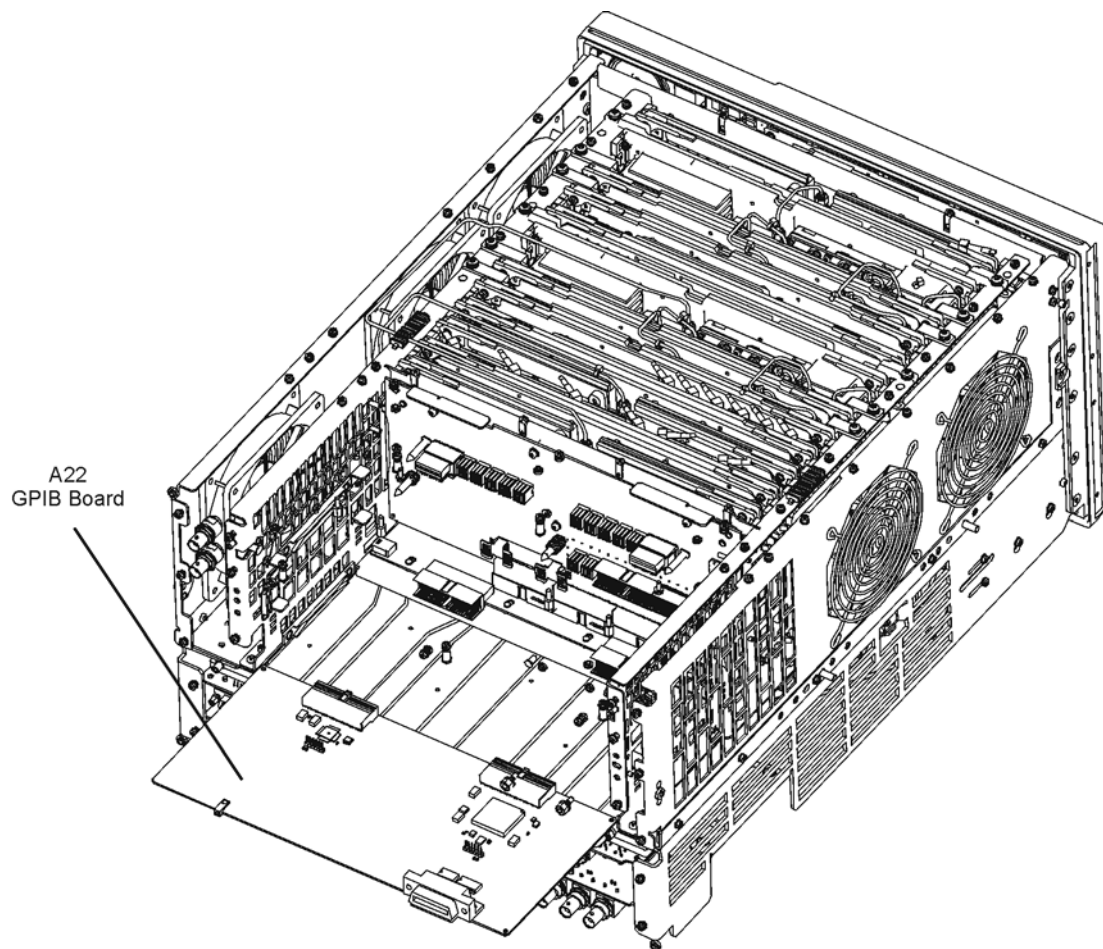

N5225_001_709

Removing and Replacing the A23 Test Set Motherboard

Tools Required

- T-10 TORX driver (torque to 9 in-lb or 1.02 N.m)
- T-20 TORX driver (torque to 21 in-lb or 2.38 N.m)
- 5/16 inch open-end torque wrench (torque to 10 in-lb or 1.13 N.m)
- 5/8 inch nutsetter (torque to 21 in-lb)
- ESD grounding wrist strap

Removal Procedure

Refer to [Figure 7-12](#) for this procedure.

1. Disconnect the power cord.
2. Remove the outer cover. Refer to [“Removing the Covers” on page 7-6](#).
3. Position the analyzer bottom side up.
4. Disconnect ALL ribbon cables (item ①) and ALL wire harnesses (item ②) from the A23 test set motherboard.
5. Remove connector hardware (item ③) from 11 rear panel BNC connectors.
6. Remove 10 screws (item ⑤) from the A23 test set motherboard.
7. Slide the A23 test set motherboard toward the front of the instrument until the rear panel BNC connectors are free of the rear panel, then lift the motherboard and remove it from the analyzer.

Replacement Procedure

1. Reverse the order of the removal procedure.
2. Perform the post-repair adjustments, verifications, and performance tests that pertain to this removal procedure. Refer to [Table 7-2 on page 7-56](#).

Figure 7-12 A23 Test Set Motherboard Removal

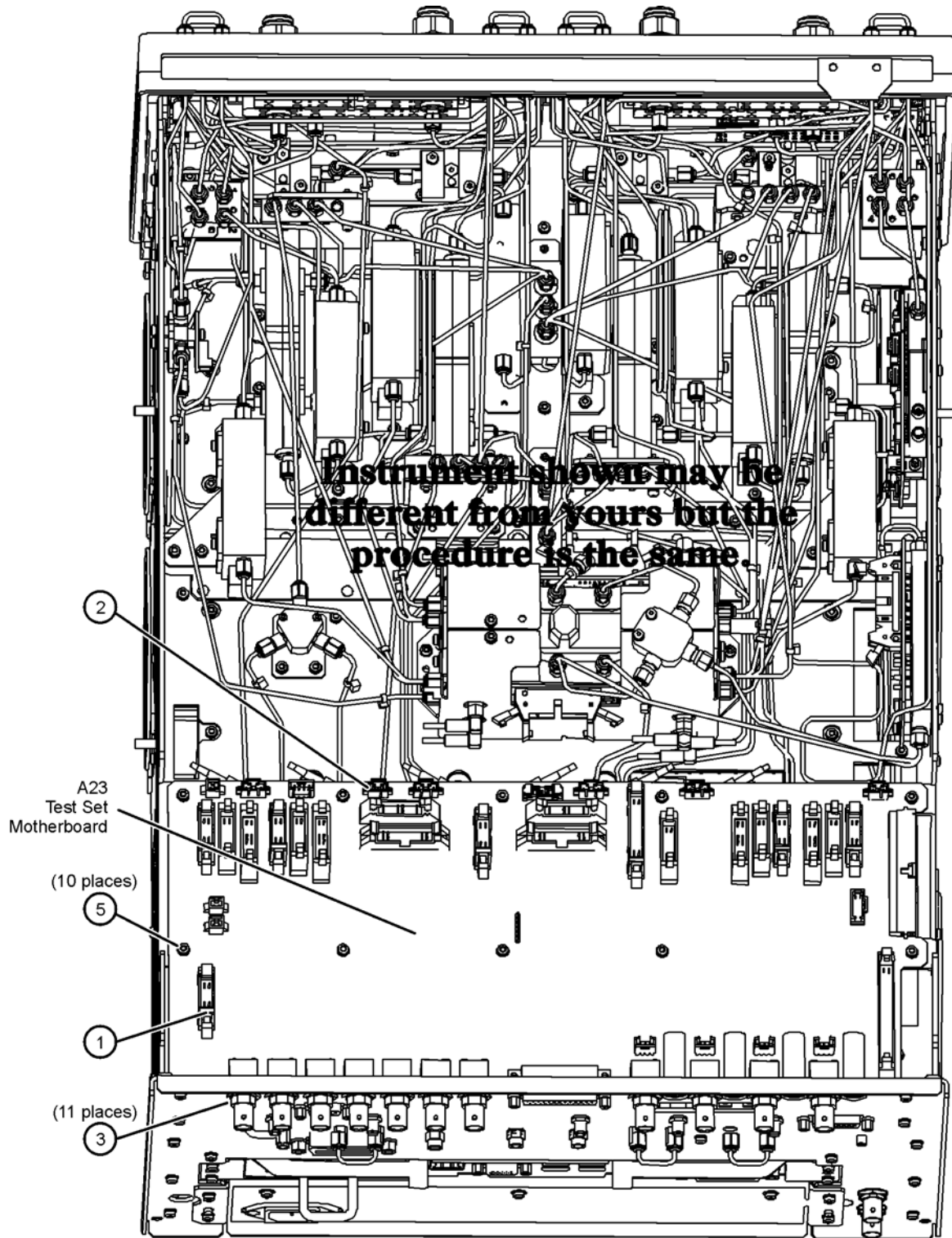

N5225_001_714

Removing and Replacing the A24 IF Multiplexer Board

Tools Required

- T-10 TORX driver (torque to 9 in-lb or 1.02 N.m)
- T-20 TORX driver (torque to 21 in-lb or 2.38 N.m)
- 5/16 inch open-end torque wrench (torque to 10 in-lb or 1.13 N.m)
- ESD grounding wrist strap

Removal Procedure

Refer to [Figure 7-13](#) for this procedure.

1. Disconnect the power cord.
2. Remove the outer cover. Refer to [“Removing the Covers” on page 7-6](#).
3. Position the analyzer bottom side up.
4. Remove the A23 test set motherboard. Refer to [“Removing and Replacing the A23 Test Set Motherboard” on page 7-26](#).
5. Disconnect the ribbon cable (item ①) from the A24 IF multiplexer board.
6. Disconnect ALL gray flexible RF cables (item ②) from the A24 IF multiplexer board.
7. Remove connector hardware (item ③) from five rear panel RF connectors.
8. Remove connector hardware (item ④) from the rear panel PULSE I/O connector.
9. Remove four screws (item ⑤) from the stabilizer bracket and remove the stabilizer bracket.
10. Remove four screws (item ⑥) from the A24 IF multiplexer board.
11. Slide the A24 IF multiplexer board toward the front of the instrument until the rear panel connectors are free of the rear panel, then lift the multiplexer board and remove it from the analyzer.

Replacement Procedure

1. Reverse the order of the removal procedure.

Attach the stabilizer bracket to the new A24 IF multiplexer board using the screws removed from the old one.

Torque rear panel RF connector nuts to 21 in-lbs and PULSE I/O connector screws to 6 in-lbs.

2. Perform the post-repair adjustments, verifications, and performance tests that pertain to this removal procedure. Refer to [Table 7-2 on page 7-56](#).

Figure 7-13 A24 IF Multiplexer Board Removal

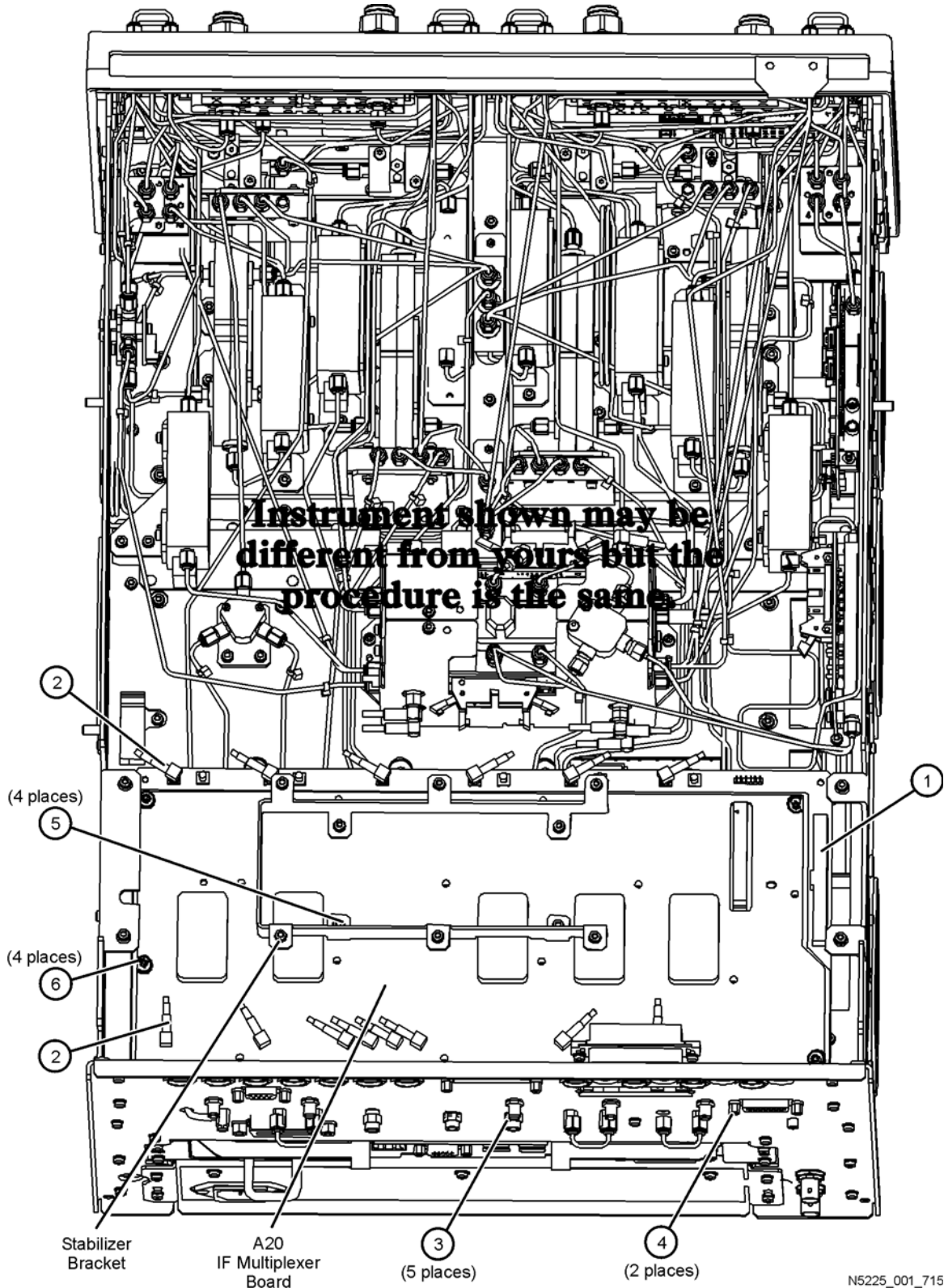

Removing and Replacing the A25 HMA26.5

Tools Required

- T-10 TORX driver (torque to 9 in-lb or 1.02 N.m)
- T-20 TORX driver (torque to 21 in-lb or 2.38 N.m)
- 5/16 inch open-end torque wrench (torque to 10 in-lb or 1.13 N.m)
- ESD grounding wrist strap

Removal Procedure

Refer to [Figure 7-14](#) for this procedure.

CAUTION Be careful not to damage the center pins of the semirigid cables. Some flexing of the cables is necessary to remove assemblies but do not over-bend them.

1. Disconnect the power cord.
2. Remove the outer cover. Refer to [“Removing the Covers” on page 7-6](#).
3. Position the analyzer bottom side up.
4. Disconnect the ribbon cable (item ①) from the A25 HMA26.5 assembly.
5. Disconnect semirigid cables (item ②) from the A25 HMA26.5. It may be necessary to loosen the other end of the cables to allow them to be moved. Do not over-bend them.
6. Remove four screws (item ③) that hold the A25 HMA26.5 to the chassis side panel.

Replacement Procedure

1. Reverse the order of the removal procedure.
Torque all RF cable connectors to 10 in-lbs.
2. Perform the post-repair adjustments, verifications, and performance tests that pertain to this removal procedure. Refer to [Table 7-2 on page 7-56](#).

Figure 7-14 A25 HMA26.5 Removal

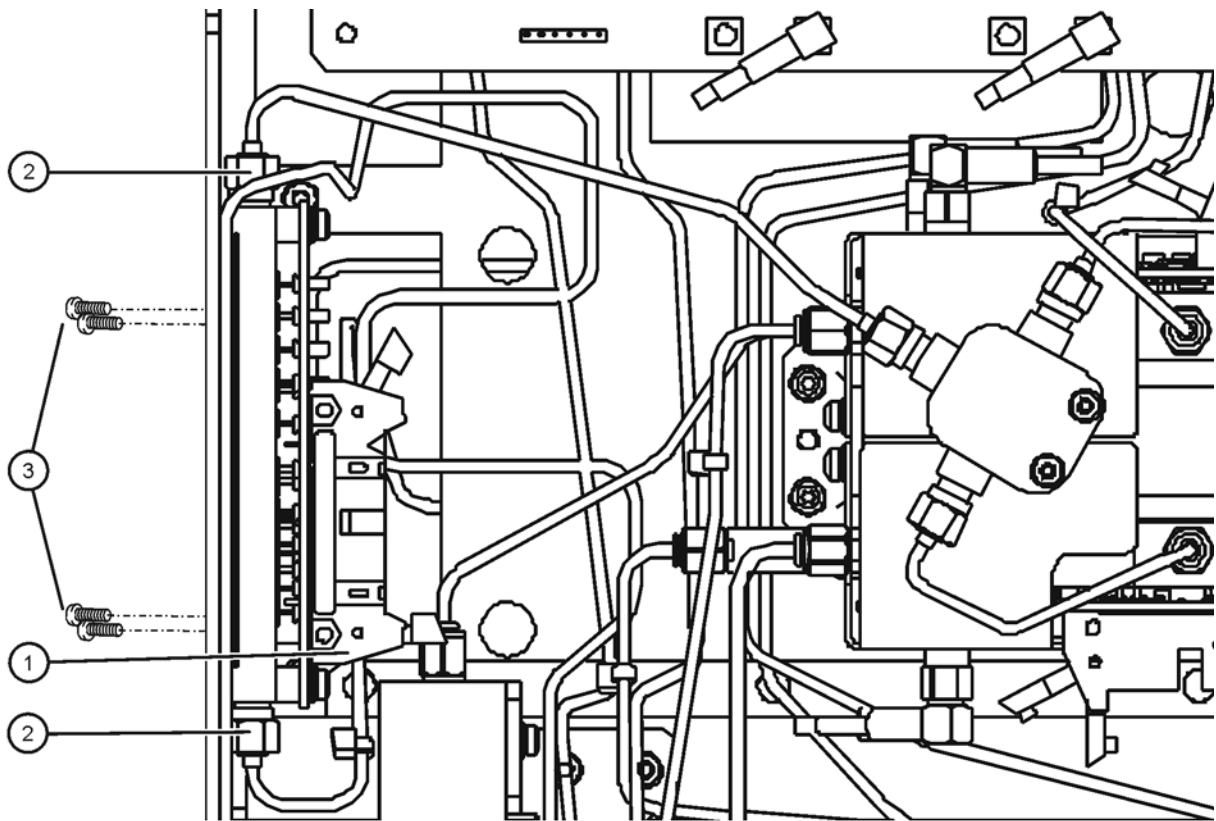

N5225_001_716

Removing and Replacing the A26 Splitter

Tools Required

- T-8 TORX driver (torque to 6 in-lb)
- T-20 TORX driver (torque to 21 in-lb)
- 5/16 inch open-end torque wrench (torque to 10 in-lb)
- ESD grounding wrist strap

Removal Procedure

Refer to [Figure 7-15](#) for this procedure.

CAUTION Be careful not to damage the center pins of the semirigid cables. Some flexing of the cables is necessary to remove assemblies but do not over-bend them.

1. Disconnect the power cord.
2. Remove the outer cover. Refer to [“Removing the Covers” on page 7-6](#).
3. Position the analyzer bottom side up.
4. Disconnect semirigid cables (item ①) from the A26 splitter. It may be necessary to loosen the other end of the cables to allow them to be moved. Do not overbend them.
5. Remove two screws (item ②) from the A26 splitter and lift the splitter out of the analyzer.

Replacement Procedure

1. Reverse the order of the removal procedure.
Torque all RF cable connections to 10 in-lbs.
2. Perform the post-repair adjustments, verifications, and performance tests that pertain to this removal procedure. Refer to [Table 7-2 on page 7-56](#).

Figure 7-15 A26 Splitter Removal

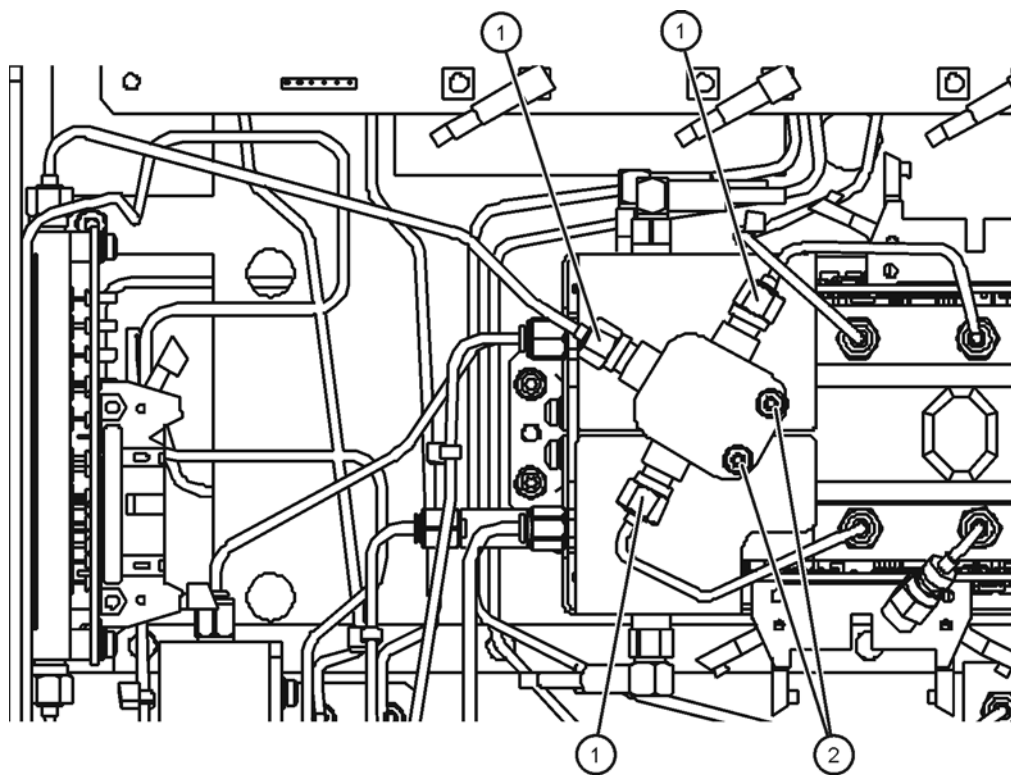

N5225_001_717

Removing and Replacing the A27 and A28 Mixer Bricks

Tools Required

- T-8 TORX driver (torque to 6 in-lb)
- T-10 TORX driver (torque to 9 in-lb)
- T-20 TORX driver (torque to 21 in-lb)
- 5/16 inch open-end torque wrench (torque to 10 in-lb)
- ESD grounding wrist strap

Removal Procedure

Refer to [Figure 7-16](#) for this procedure.

CAUTION Be careful not to damage the center pins of the semirigid cables. Some flexing of the cables is necessary to remove assemblies but do not over-bend them.

1. Disconnect the power cord.
2. Remove the outer cover. Refer to [“Removing the Covers” on page 7-6](#).
3. Position the analyzer bottom side up.
4. Disconnect all semirigid cables (item ①) from each of the mixer bricks and the A26 splitter. 2-port models have only one mixer brick, A27, and no A26 splitter; 4-port models have two mixer bricks, A27 and A28, and the A26 splitter.
5. Disconnect the ribbon cables (item ②) from each of the mixer bricks.
6. Remove two screws (item ③) from each end of the mixer brick bracket.
7. Move the disconnected semirigid cables out of the way and lift the mixer brick mounting block out of the analyzer just enough to allow the gray flexible RF cables (item ④) to be disconnected. It may be necessary to loosen the connector at the other end of some of the semirigid cables to allow them to be moved enough.

Note the locations of each of the gray flexible cables for reconnection later. If necessary, refer to the appropriate bottom cable illustration in [Chapter 6](#).

Disconnect these cables and remove the mixer brick mounting block, with the mixer brick(s), the mixer brick shields, and the A26 splitter attached, from the analyzer.
8. If replacing a mixer brick:
 - a. Remove the two screws (item ⑤) from each shield.
 - b. Remove 3 screws (not shown) that fasten each mixer brick to the mixer brick mounting block.

Replacement Procedure

1. Reverse the order of the removal procedure.

If replacing the A28 mixer brick, remember to move the dust cap/termination (item ⑥) from the old mixer brick to the new mixer brick in the same location.

Some 2-port models and some 4-port models have a 3-dB pad on the A27 mixer brick R1 connection and all 4-port models have a 3-dB pad on the A28 mixer brick R4 connection. If appropriate, be sure to move the pad(s) from the old mixer brick(s) to the new mixer brick(s).

Torque all RF cable connections to 10 in-lbs.

2. Perform the post-repair adjustments, verifications, and performance tests that pertain to this removal procedure. Refer to [Table 7-2 on page 7-56](#).

Figure 7-16 A27 and A28 Mixer Bricks Removal

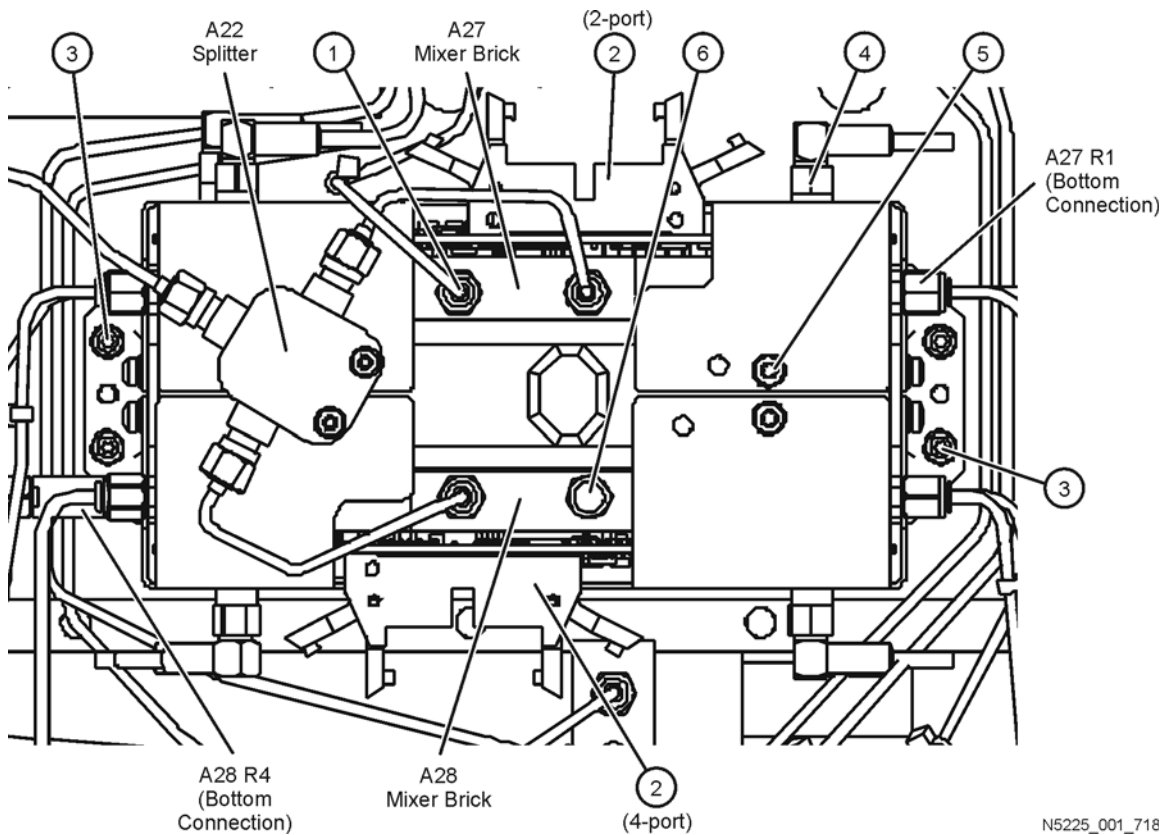

Removing and Replacing the A29–A32 Receiver Couplers and Receiver Coupler Mounting Brackets

Tools Required

- T-6 TORX driver (torque to 4 in-lb or 0.45 N.m)
- T-10 TORX driver (torque to 9 in-lb or 1.02 N.m)
- 5/16 inch open-end torque wrench (torque to 10 in-lb or 1.13 N.m)
- ESD grounding wrist strap

Removal Procedure

Refer to [Figure 7-17](#) for this procedure.

CAUTION Be careful not to damage the center pins of the semirigid cables. Some flexing of the cables is necessary to remove assemblies but do not over-bend them.

1. Disconnect the power cord.
2. Remove the outer cover. Refer to [“Removing the Covers” on page 7-6](#).
3. Position the analyzer bottom side up.
4. Disconnect three semirigid cables (item ①) from the receiver coupler to be replaced.
5. Remove two screws (item ②) from the mounting bracket of the receiver coupler to be replaced.
6. Move the disconnected semirigid cables out of the way and lift the receiver coupler mounting bracket, with the receiver coupler attached, out of the analyzer. It may be necessary to loosen the connector at the other end of some of the semirigid cables to allow them to be moved enough. Do not overbend them.
7. Remove four screws that attach the receiver coupler to the receiver coupler mounting bracket, and remove the receiver coupler from the bracket.

Replacement Procedure

1. Reverse the order of the removal procedure.
Torque all RF connectors to 10 in-lbs.
2. Perform the post-repair adjustments, verifications, and performance tests that pertain to this removal procedure. Refer to [Table 7-2 on page 7-56](#).

N5224A and N5225A Removing and Replacing the A29–A32 Receiver Couplers and Receiver Coupler Mounting Brackets

Figure 7-17 A29 through A32 receiver couplers Removal

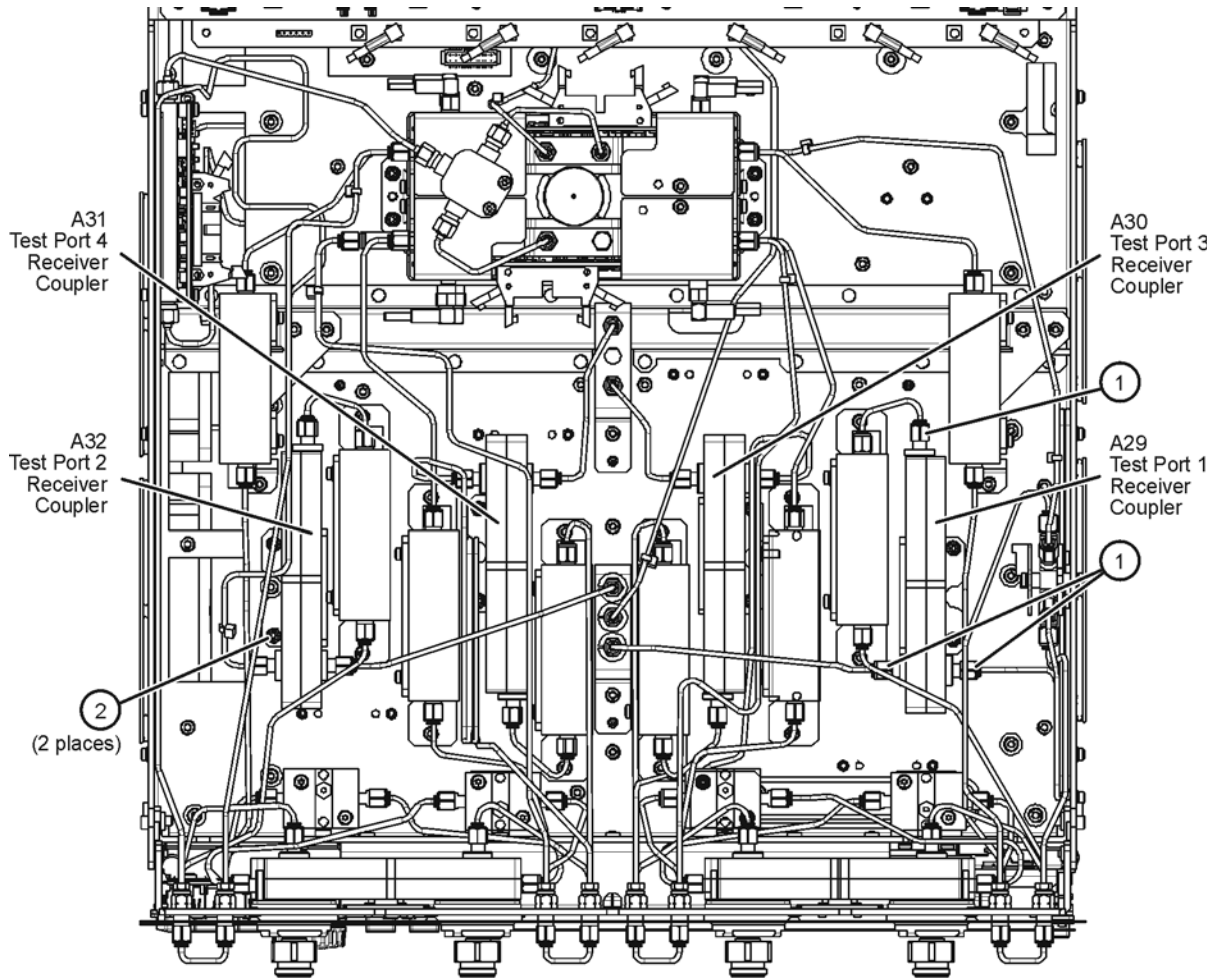

(Some parts removed for clarity.)

N5225_001_719

Removing and Replacing the A33–A36 Test Port Couplers

Tools Required

- T-10 TORX driver (torque to 9 in-lb or 1.02 N.m)
- T-20 TORX driver (torque to 21 in-lb or 2.38 N.m)
- 5/16 inch open-end torque wrench (torque to 10 in-lb or 1.13 N.m)
- 1 inch open-end torque wrench (torque to 72 in-lb or 8.15 N.m)
- ESD grounding wrist strap

Removal Procedure

Refer to [Figure 7-18](#) for this procedure.

CAUTION Be careful not to damage the center pins of the semirigid cables. Some flexing of the cables is necessary to remove assemblies but do not over-bend them.

1. Disconnect the power cord.
2. Remove the front panel assembly. Refer to [“Removing and Replacing the Front Panel Assembly” on page 7-8](#).
3. Position the analyzer bottom side up.
4. On 4-port models, it is necessary to remove the couplers in pairs: ports 1/3 and 2/4.
5. Disconnect two semirigid cables (item ①) from each coupler to be removed. It may be necessary to loosen the other end of the cables to allow them to be moved. Do not overbend them.
6. Disconnect the wire harness (item ②) from the corresponding front panel LED board and place it out of the way.
7. Remove the coupler nut (item ③) from each coupler to be removed.
8. Move the disconnected semirigid cables out of the way and remove the coupler(s) from the analyzer. It may be necessary to remove other cables to remove the coupler(s). If so, make note of the connection locations for reinstallation later.

Replacement Procedure

1. Reverse the order of the removal procedure.

Adhere a new gap pad (4-port) or coupler bumper (2-port) (item ④) to the new coupler in the same location as on the old one. Replace the vibration mount (item ⑤) if necessary. Refer to [“Bottom Hardware and Miscellaneous Parts” on page 6-92](#) for replacement part numbers. Torque all connectors to 10 in-lbs. Torque coupler nuts to 72 in-lbs.

2. Perform the post-repair adjustments, verifications, and performance tests that pertain to this removal procedure. Refer to [Table 7-2 on page 7-56](#).

Figure 7-18 A33 through A36 Test Port Couplers Removal

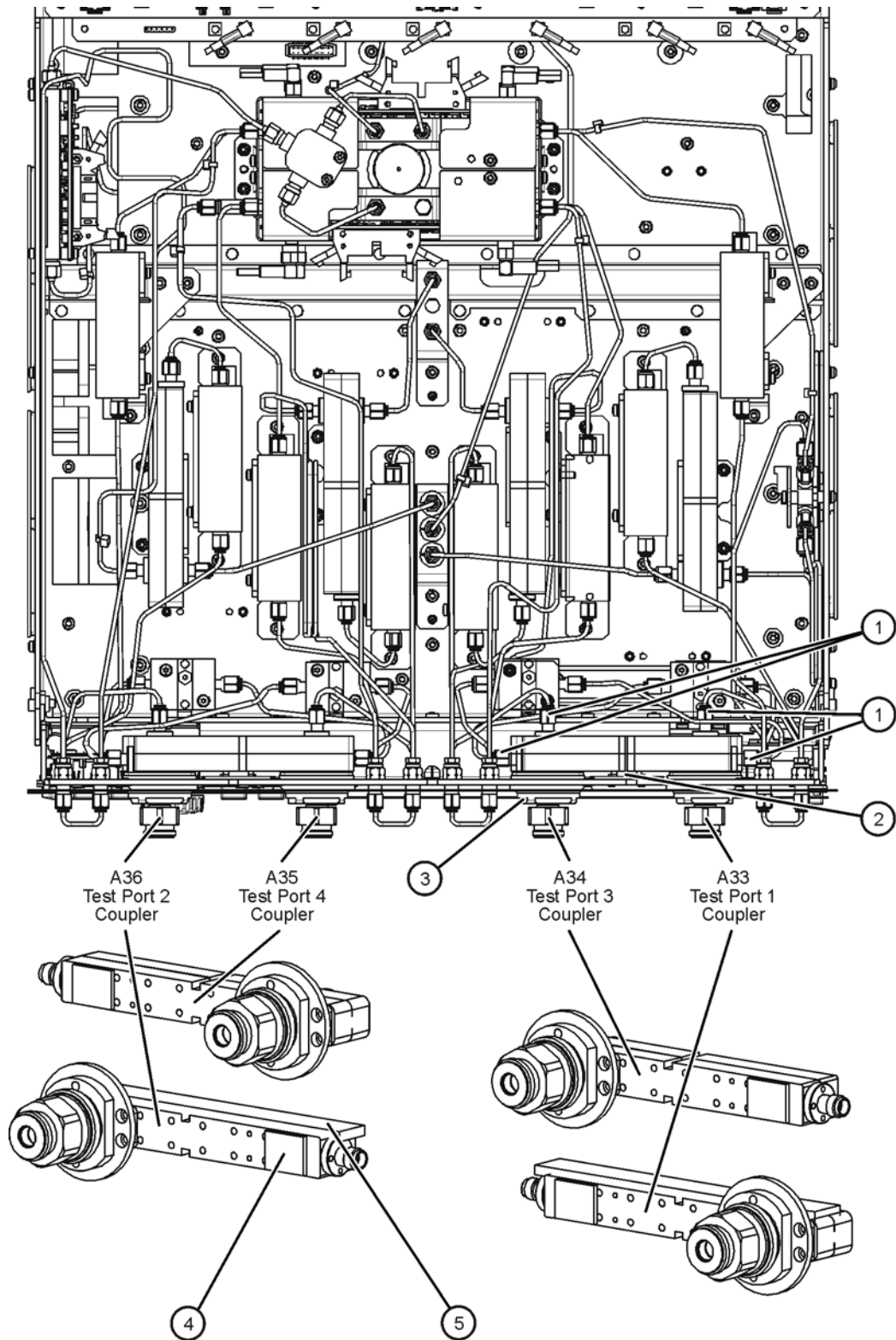

N5225_001_720

Removing and Replacing the A37 Reference Mixer Switch

Tools Required

- T-10 TORX driver (torque to 9 in-lb or 1.02 N.m)
- T-20 TORX driver (torque to 21 in-lb or 2.38 N.m)
- 5/16 inch open-end torque wrench (torque to 10 in-lb or 1.13 N.m)
- ESD grounding wrist strap

Removal Procedure

Refer to [Figure 7-19](#) for this procedure.

CAUTION Be careful not to damage the center pins of the semirigid cables. Some flexing of the cables is necessary to remove assemblies but do not over-bend them.

1. Disconnect the power cord.
2. Remove the outer cover. Refer to [“Removing the Covers” on page 7-6](#).
3. Position the analyzer bottom side up.
4. Disconnect four semirigid cables (item ①) from the A37 reference mixer switch.
5. Remove two screws (item ②) that secure the A37 reference mixer switch to the side of the test set deck.
6. Move the disconnected semirigid cables out of the way and lift the A37 reference mixer switch and mounting bracket out of the analyzer. It may be necessary to loosen the other end of the cables to allow them to be moved. Do not overbend them.
7. Disconnect the wire harness cable (item ③) from the A37 reference mixer switch.
8. Remove two screws (item ④) that attach the A37 reference mixer switch to its mounting bracket.

Replacement Procedure

1. Reverse the order of the removal procedure.

When reinstalling the A37 reference mixer switch into the analyzer, loosely install the two mounting screws (item ②). Connect the four semirigid cables (item ①) and torque the connectors to 10 in-lbs, then tighten the mounting screws.

2. Perform the post-repair adjustments, verifications, and performance tests that pertain to this removal procedure. Refer to [Table 7-2 on page 7-56](#).

Figure 7-19 A37 Reference Mixer Switch Removal

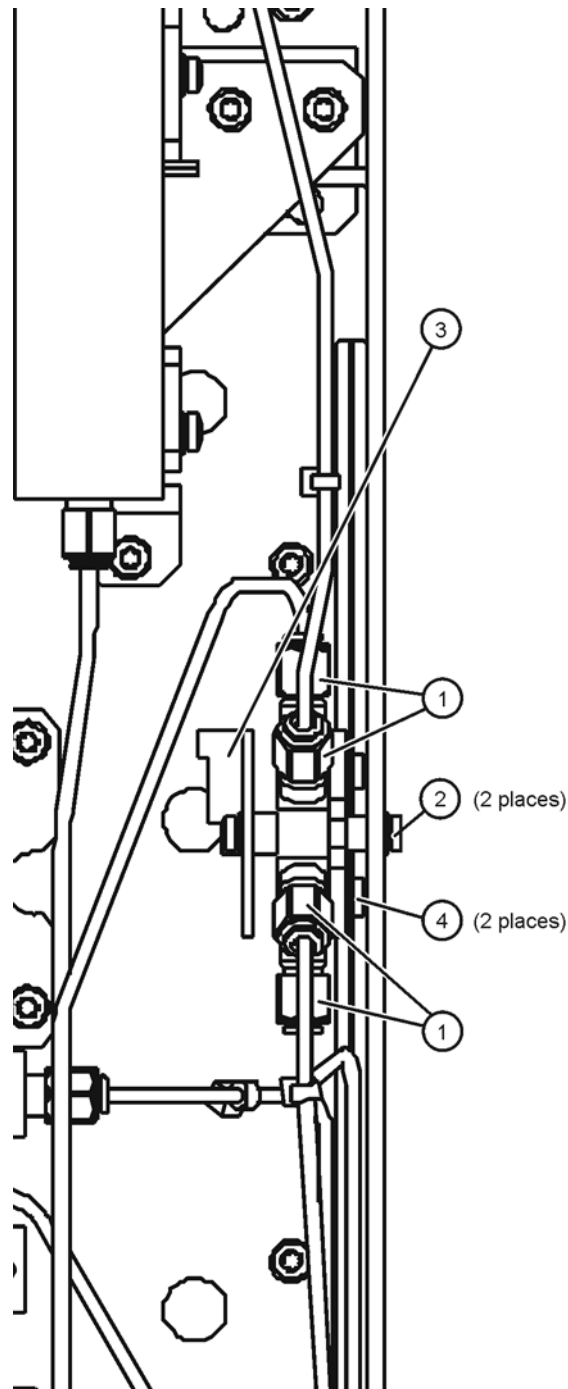

N5225_001_721

Removing and Replacing the A38–A41 Source Attenuators and the A46–A49 Receiver Attenuators

Tools Required

- T-10 TORX driver (torque to 9 in-lb or 1.02 N.m)
- T-20 TORX driver (torque to 21 in-lb or 2.38 N.m)
- 5/16 inch open-end torque wrench (torque to 10 in-lb or 1.13 N.m)
- ESD grounding wrist strap

Removal Procedure

Refer to [Figure 7-20](#) for this procedure.

CAUTION Be careful not to damage the center pins of the semirigid cables. Some flexing of the cables is necessary to remove assemblies but do not over-bend them.

1. Disconnect the power cord.
2. Remove the outer cover. Refer to [“Removing the Covers” on page 7-6](#).
3. Position the analyzer bottom side up.
4. Disconnect the ribbon cable (item ①) from each attenuator to be removed.
5. Disconnect two semirigid cables (item ②) from each attenuator to be removed. It may be necessary to remove additional cables to remove the attenuator bracket. If so, note the location and orientation of each for reinstallation later.
6. Remove three screws (item ③) that secure A46 and A49 receiver attenuator brackets to the test set deck, or remove two screws (item ③) that secure A47 and A48 receiver attenuator brackets or all source attenuator brackets to the test set deck.
7. Move the disconnected semirigid cables out of the way and lift the attenuator bracket out of the analyzer, with the attenuator attached. It may be necessary to loosen the other end of the cables to allow them to be moved. Do not overbend them.
8. Remove two screws (item ④) to remove the attenuator to be replaced, from the mounting bracket.

Replacement Procedure

1. Reverse the order of the removal procedure.
Torque all cable connections to 10 in-lbs.
2. Perform the post-repair adjustments, verifications, and performance tests that pertain to this removal procedure. Refer to [Table 7-2 on page 7-56](#).

Figure 7-20 Source and Receiver Attenuators

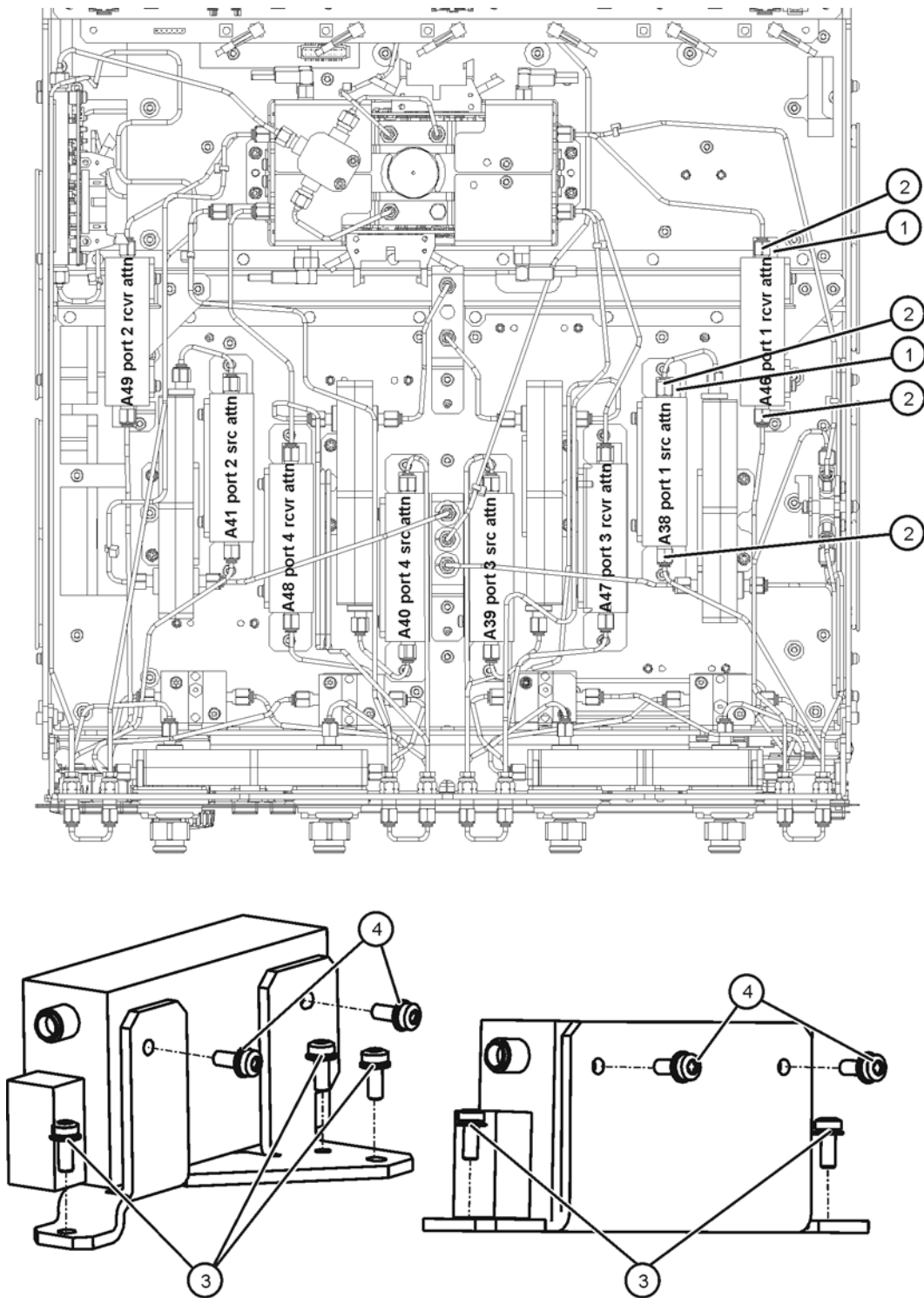

Receiver Attenuators
A46 & A49
Bracket position shown for A49;
A46 bracket on opposite side.

Receiver Attenuators
A47 & A48 and all
Source Attenuators

N5225_001_722

Removing and Replacing the A42–A45 Bias Tees

Tools Required

- T-10 TORX driver (torque to 9 in-lb or 1.02 N.m)
- T-20 TORX driver (torque to 21 in-lb or 2.38 N.m)
- 5/16 inch open-end torque wrench (torque to 10 in-lb or 1.13 N.m)
- ESD grounding wrist strap

Removal Procedure

Refer to [Figure 7-21](#) for this procedure.

CAUTION Be careful not to damage the center pins of the semirigid cables. Some flexing of the cables is necessary to remove assemblies but do not over-bend them.

1. Disconnect the power cord.
2. Remove the outer cover. Refer to [“Removing the Covers” on page 7-6](#).
3. Position the analyzer bottom side up.
4. Disconnect two semirigid cables (item ①) from the bias tee to be removed.
5. Remove two screws (item ②) from the bias tee to be removed. Make note of the location of the wire harness cable ground wire for reinstallation later.
6. Disconnect the wire harness cable (item ③) from the A23 test set motherboard.
7. Move the disconnected semirigid cables out of the way and remove the bias tee from the analyzer. It may be necessary to loosen the other end of the cables to allow them to be moved. Do not overbend them.

Replacement Procedure

1. Reverse the order of the removal procedure.
Torque all cable connections to 10 in-lbs.
Remember to place the wire harness cable ground lug on the proper mounting screw.
2. Perform the post-repair adjustments, verifications, and performance tests that pertain to this removal procedure. Refer to [Table 7-2 on page 7-56](#).

Figure 7-21 A42 through A45 Bias Tees Removal

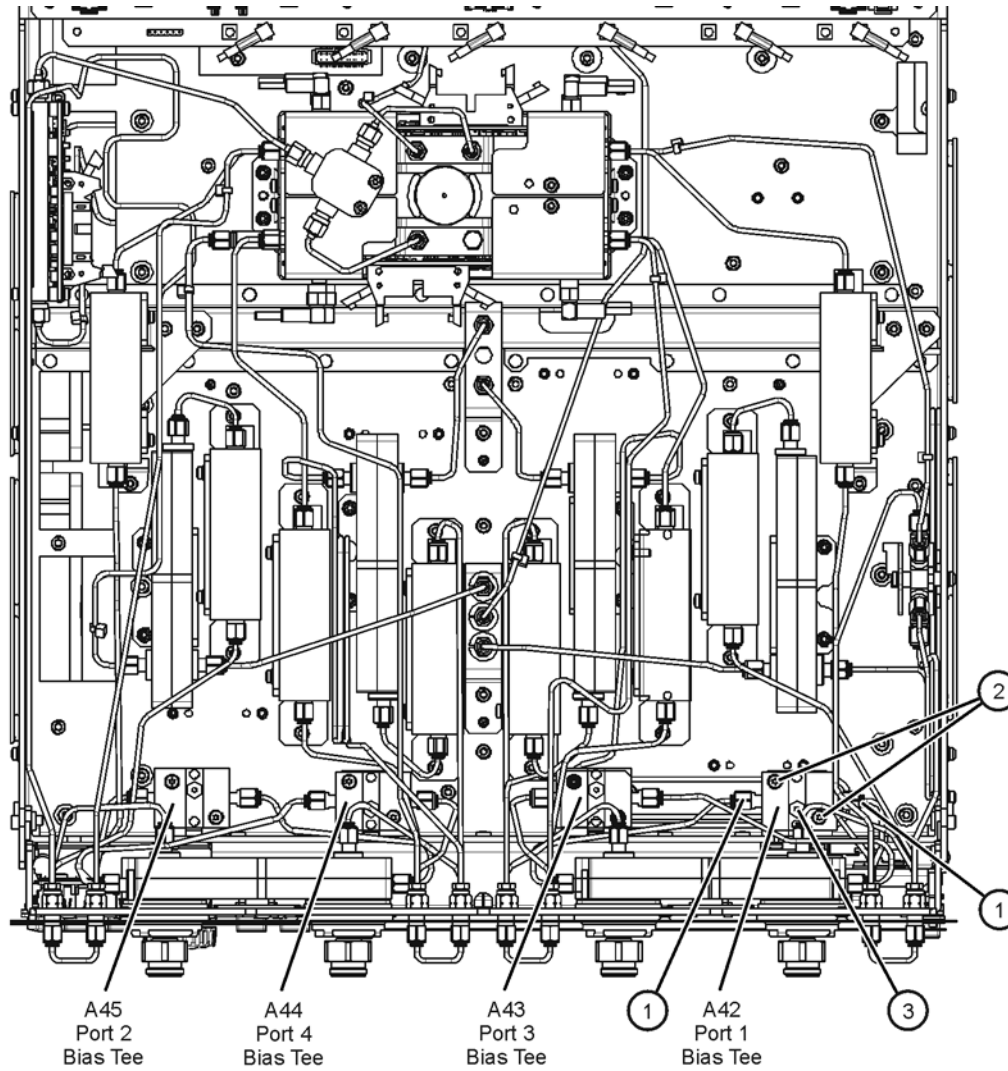

N5225_001_723

Removing and Replacing the A55 Solid State Drive (SSD)

Certain unique files exist on the SSD that are necessary for proper operation of your analyzer. These files must be copied to another location to allow them to be installed onto the new SSD after it has been installed.

If you are replacing the SSD, the following procedure must be performed first.

Copy Unique Files from the SSD

If installing an SSD for Windows XP: if the user has loaded unique calibration kit information, navigate to C:\Program Files\Keysight\Network Analyzer and copy USER_CALKITFILE to a USB flash memory drive. Also copy any personal user files that you wish to preserve.

If installing an SSD for Windows 7: for more information on the N8983A SSD, refer to the *Windows 7 Operating System Upgrade Kit Installation Note*, available online at <http://literature.cdn.keysight.com/litweb/pdf/N8983-90001.pdf>.

Tools Required

- T-10 TORX driver (torque to 9 in-lb or 1.02 N.m; for solid state drive replacement)
- ESD grounding wrist strap

Removal Procedure

Refer to [Figure 7-22](#) for this procedure.

1. Disconnect the analyzer power cord.
2. Position the analyzer for access to the rear panel.
3. Loosen the SSD assembly thumb screw (item ①).
4. Pull the SSD assembly out from the CPU assembly, using the handle (item ②).

Figure 7-22 SSD Removal

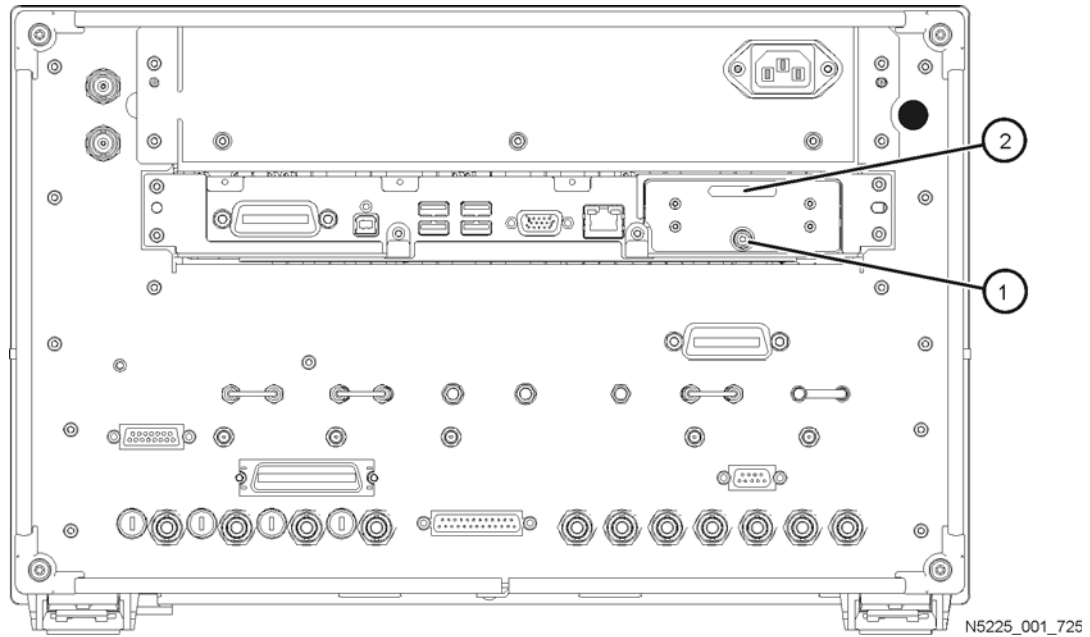

Reinstalling the SSD

Reverse the order of the removal procedure.

Install Backup Files onto the New SSD

The files that were previously saved onto a USB flash memory drive must now be installed onto the new SSD. The network analyzer must be powered up and operating.

Removing and Replacing the Rear Panel

Tools Required

- T-10 TORX driver (torque to 9 in-lb or 1.02 N.m)
- T-20 TORX driver (torque to 21 in-lb or 2.38 N.m)
- 5/16 inch nutsetter (torque to 10 in-lb or 1.13 N.m)
- 5/16 inch nutsetter (torque to 21 in-lb or 2.38 N.m)
- 5/8 inch nutsetter (torque to 21 in-lb or 2.38 N.m)
- 9/32 inch nutsetter (torque to 9 in-lb or 1.02 N.m)
- 3/16 inch nutsetter (torque to 6 in-lb or 0.68 N.m)
- 9/16 inch nutsetter (torque to 21 in-lb or 2.38 N.m)
- 9 mm nutsetter (torque to 21 in-lb or 2.38 N.m)
- ESD grounding wrist strap

Removal Procedure

Refer to [Figure 7-23](#) for this procedure.

1. Disconnect the power cord.
2. Remove the outer and inner covers. Refer to [“Removing the Covers” on page 7-6](#).
3. Remove the A20 power supply assembly. Refer to [“Removing and Replacing the A20 Power Supply Assembly” on page 7-20](#).
4. Remove the A21 CPU board assembly. Refer to [“Removing and Replacing the A21 CPU Board Assembly” on page 7-22](#).
5. Remove the 50 ohm load(s) (item ②).
6. Remove the connector hardware (item ③) from each of the five multi-pin connectors. The hardware is not the same on each connector so note which hardware goes with which connector.
7. Remove the connector hardware (item ④) from each of the RF connectors. The hardware is not the same on each connector so note which hardware goes with which connector.
8. Remove the 13 screws (item ⑤) that attach the rear panel to the chassis.
9. Slide the rear panel over the cable connectors and off of the analyzer.

Replacement Procedure

1. Reverse the order of the removal procedure.
2. Perform the post-repair adjustments, verifications, and performance tests that pertain to this removal procedure. Refer to [Table 7-2 on page 7-56](#).

Figure 7-23 Rear Panel Removal

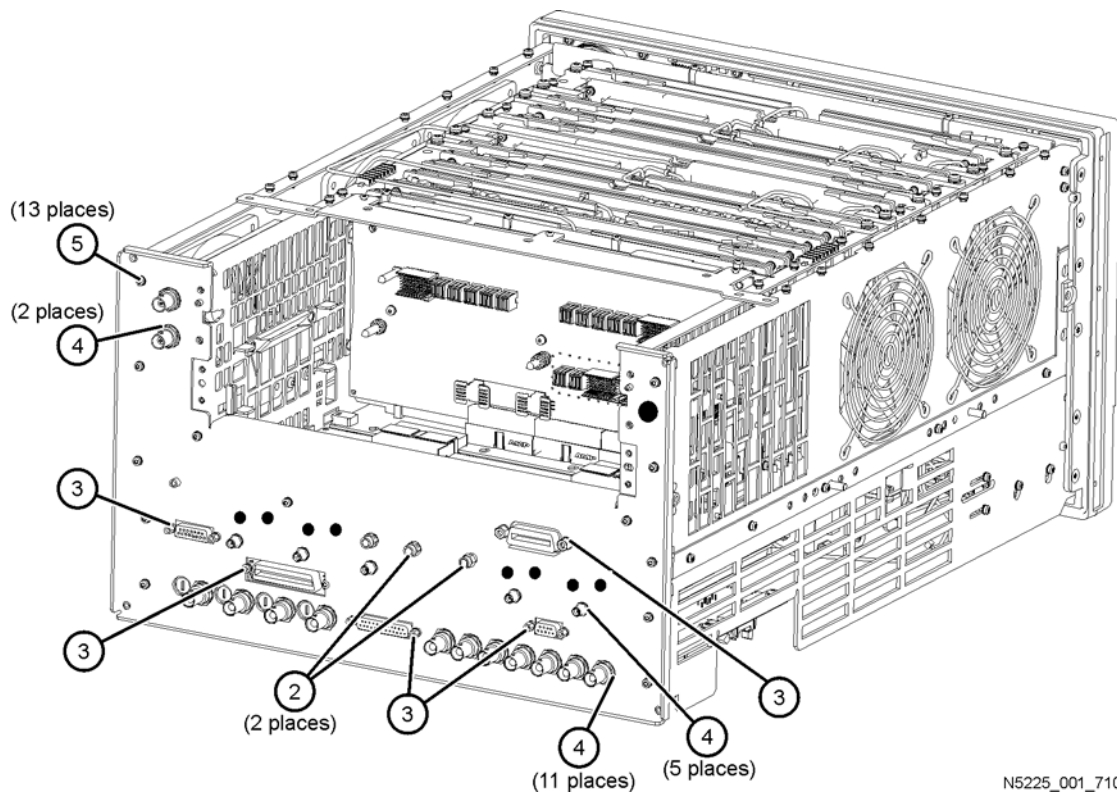

Removing and Replacing the Front Panel LED Boards

Tools Required

- T-10 TORX driver (torque to 9 in-lb)
- T-20 TORX driver (torque to 21 in-lb)
- 5/16 inch open-end torque wrench (torque to 10 in-lb)
- 1 inch open-end torque wrench (torque to 72 in-lb or 8.15 N.m)
- ESD grounding wrist strap

Removal Procedure

Refer to [Figure 7-18](#) for this procedure.

CAUTION Be careful not to damage the center pins of the semirigid cables. Some flexing of the cables is necessary to remove assemblies but do not over-bend them.

1. Disconnect the power cord.
2. Remove the test port couplers. Refer to [“Removing and Replacing the A33–A36 Test Port Couplers” on page 7-38](#).
3. Remove two screws (item ①) from the LED board to be removed and remove the LED board from the analyzer.

Replacement Procedure

1. Reverse the order of the removal procedure.
2. Perform the post-repair adjustments, verifications, and performance tests that pertain to this removal procedure. Refer to [Table 7-2 on page 7-56](#).

Figure 7-24 Front Panel LED Boards Removal

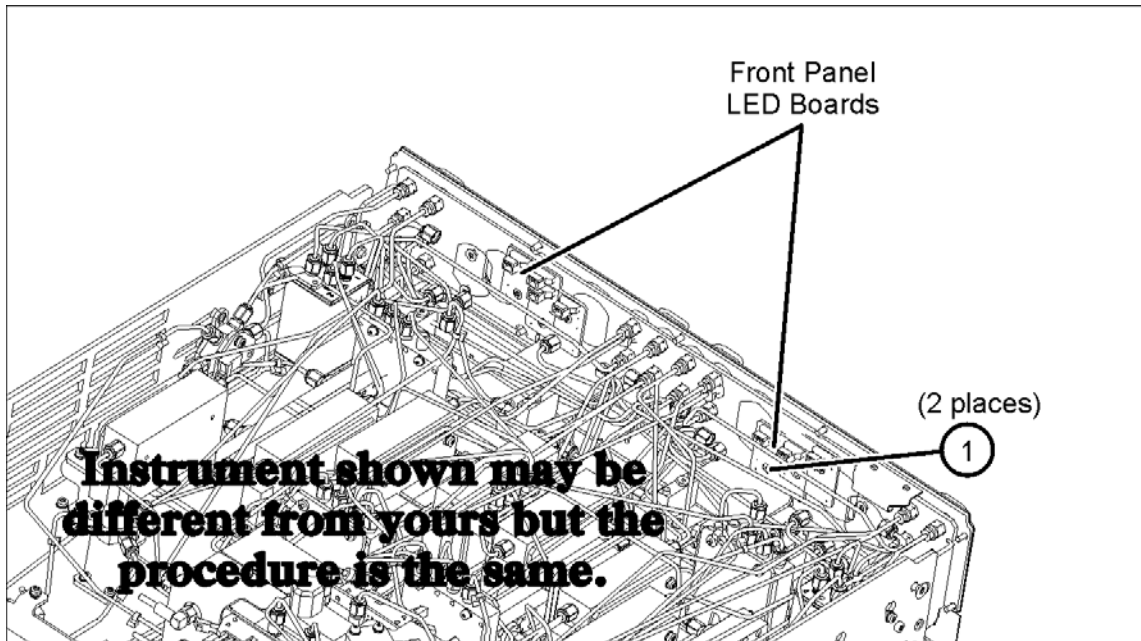

N5225_001_726

Removing and Replacing the Fans

Tools Required

- T-10 TORX driver (torque to 9 in-lb or 1.02 N.m)
- T-20 TORX driver (torque to 21 in-lb or 2.38 N.m)
- Pozidriv screw driver
- 5/16 inch open-end torque wrench (torque to 10 in-lb or 1.13 N.m)
- ESD grounding wrist strap

Removal Procedure

Refer to [Figure 7-25](#) for this procedure.

1. Disconnect the power cord.
2. Remove the outer and inner covers. Refer to [“Removing the Covers” on page 7-6](#).
3. Remove the front panel assembly. Refer to [“Removing and Replacing the Front Panel Assembly” on page 7-8](#).
4. Remove the power supply bracket. It is not necessary to remove the entire power supply, just the power supply bracket. Refer to [“Removing and Replacing the A20 Power Supply Assembly” on page 7-20](#).
5. Remove screws (item ①) (five on the right side and seven on the left side) that attach the fan brackets to the chassis.
6. Remove three screws (item ②) on both sides that attach the rear panel to the fan bracket.
7. Raise the fan bracket out of both sides in the analyzer just enough to access the fan cables. Disconnect the fan cables from the A18 system motherboard connectors (item ③).
8. Remove the fan brackets and fans from the analyzer.
9. To remove a fan or fan guard from the fan bracket:
 - a. Before removing a fan or fan guard, note the orientation of each fan and fan guard for reinstallation.
 - b. Pull up the center pin of each of the fan rivets as shown by (item ④) in the illustration.
 - c. Pull out the rivet completely (as shown by (item ⑤) in the illustration) to release the fan and fan guard.

Replacement Procedure

1. Reverse the order of the removal procedure.
2. Perform the post-repair adjustments, verifications, and performance tests that pertain to this removal procedure. Refer to [Table 7-2 on page 7-56](#).

Figure 7-25 B1 Fan Removal

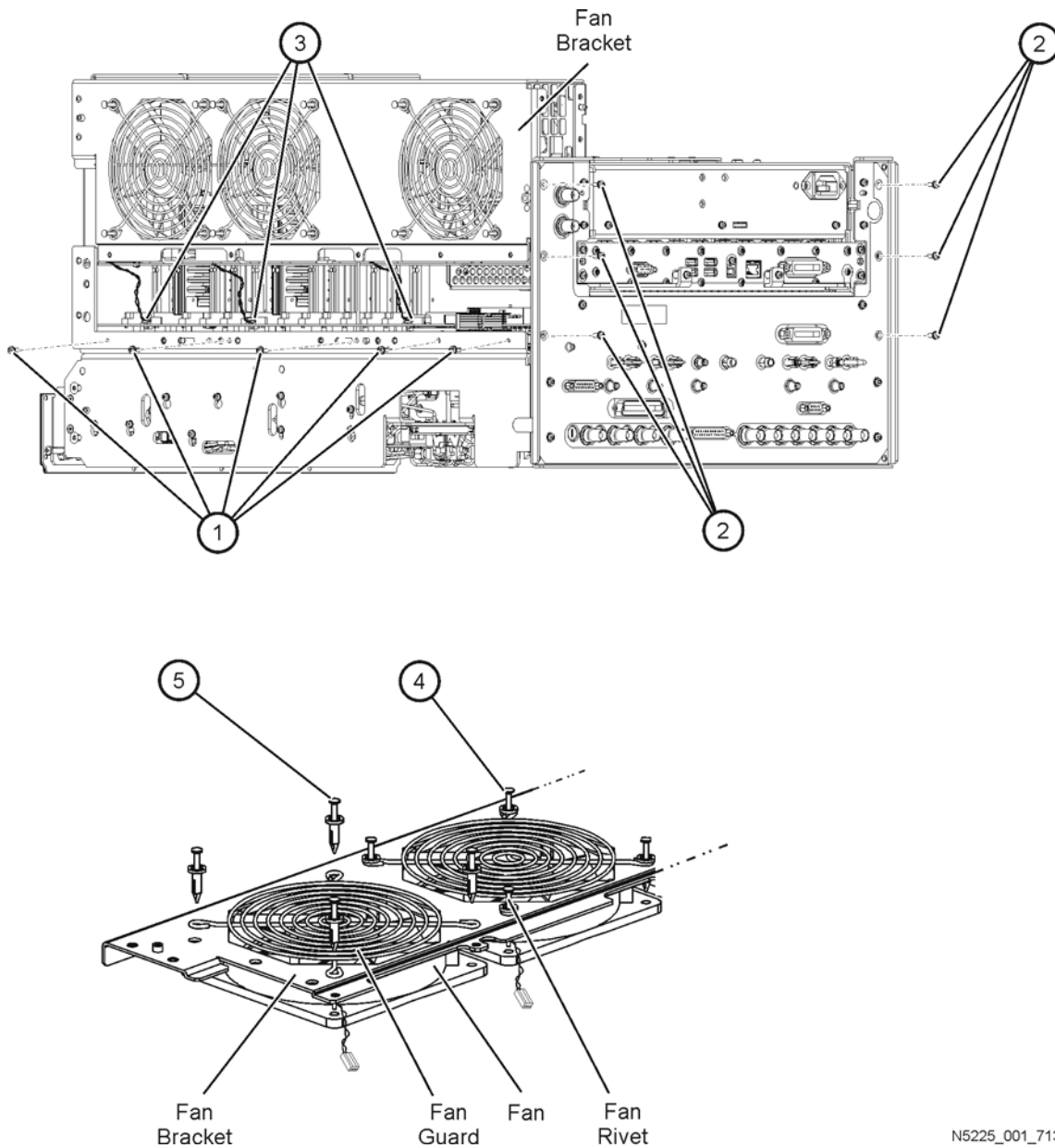

N5225_001_713

Removing and Replacing the Lithium Battery

Tools Required

- T-10 TORX driver (torque to 9 in-lb or 1.02 N.m)
- T-20 TORX driver (torque to 21 in-lb or 2.38 N.m)
- ESD grounding wrist strap

Removal Procedure

Refer to [Figure 7-26](#) for this procedure.

1. Disconnect the power cord.
2. Remove the solid state drive (SSD) from the A21 CPU board. Refer to [“Removing and Replacing the A55 Solid State Drive \(SSD\)”](#) on page 7-46.
3. Remove 22 top cover attachment screws (item ①).
4. Remove the top cover from the A21 CPU board assembly.
5. Remove the battery from the battery holder by lifting it at the open end of the holder and then sliding it from under the clip (item ②).
6. **DO NOT THROW AWAY THE BATTERY. COLLECT IT AS SMALL CHEMICAL WASTE.** Refer to [“Lithium Battery Disposal”](#) on page 1-8 for additional information on battery disposal.

Replacement Procedure

1. Reverse the order of the removal procedure following all instructions included with the new battery.
2. Perform the post-repair adjustments, verifications, and performance tests that pertain to this removal procedure. Refer to [Table 7-2](#) on page 7-56.

Figure 7-26 Lithium Battery Removal

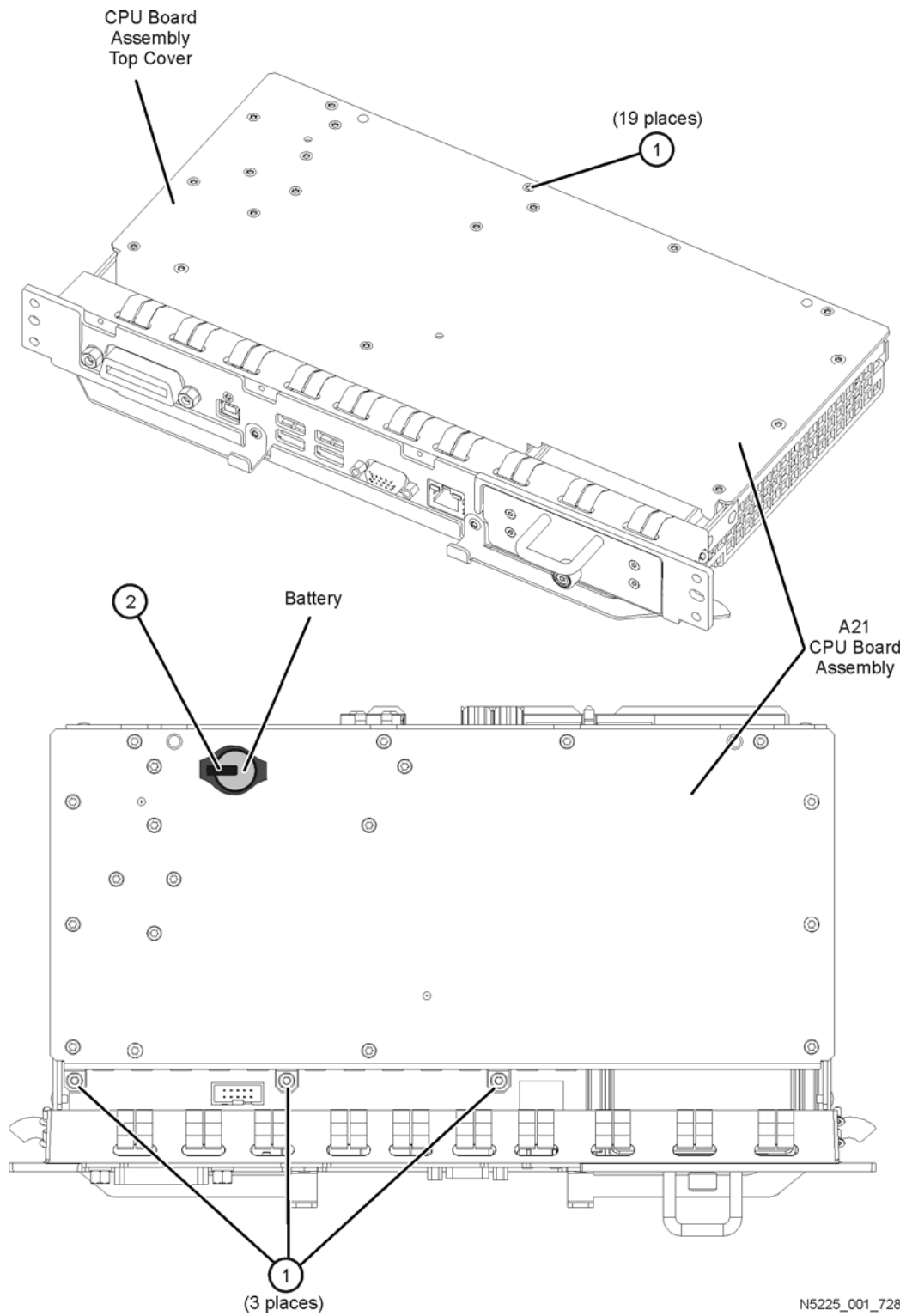

N5225_001_728

Post-Repair Procedures

After the replacement of an assembly, you must perform the service procedures in the order listed in [Table 7-2](#).

Procedures referenced in this table are located in [Chapter 3, "Tests and Adjustments,"](#) unless specified otherwise.

IMPORTANT Keysight personnel: see [Figure 1-1 on page 1-5](#) to review where the calibration stickers should be placed on the PNA.

Table 7-2 Related Service Procedures

Replaced Assembly	Adjustments and Other Procedures	Verification, Performance, and Other Tests and Procedures
A1 front panel display board	No adjustment needed	Front Panel Keypad and RPG Test and A3 Display Test in Chapter 4
A2 USB board	No adjustment needed	Check for proper operation
A3 display assembly	No adjustment needed	A3 Display Test in Chapter 4
A4 13.5 GHz source 1 synthesizer board	EE Default Adjustment: Synth Src1 only Synthesizer Bandwidth Adjustment Source Adjustment Receiver Adjustment	Source Power Accuracy Test Source Maximum Power Output Test Source Power Linearity Test The Operator's Check
A5 26.5 GHz source board	Source Adjustment Receiver Adjustment	Source Power Accuracy Test Source Maximum Power Output Test Source Power Linearity Test The Operator's Check
A7, A8, A12, and A13 Doubler boards	Source Adjustment Receiver Adjustment	Source Power Accuracy Test Source Maximum Power Output Test Source Power Linearity Test The Operator's Check
A10 26.5 GHz source board	Source Adjustment Receiver Adjustment	Source Power Accuracy Test Source Maximum Power Output Test Source Power Linearity Test The Operator's Check
A14 frequency reference board	10 MHz Frequency Reference Adjustment Restore option data (Refer to "Repairing and Recovering Option Data" in Chapter 8.)	Frequency Accuracy Test

Table 7-2 Related Service Procedures (Continued)

Replaced Assembly	Adjustments and Other Procedures	Verification, Performance, and Other Tests and Procedures
A15 13.5 GHz LO synthesizer board	EE Default Adjustment: Synth LO only Synthesizer Bandwidth Adjustment Source Adjustment IF Gain Adjustment Receiver Characterization Receiver Adjustment	Frequency Accuracy Test Source Power Accuracy Test Source Maximum Power Output Test Source Power Linearity Test The Operator's Check
A16 SPAM board	IF Gain Adjustment Receiver Characterization	Noise Floor Test Trace Noise Test
A17 13.5 GHz source 2 synthesizer board	EE Default Adjustment: Synth Src2 only Synthesizer Bandwidth Adjustment Source Adjustment Receiver Adjustment	Frequency Accuracy Test Source Power Accuracy Test Source Maximum Power Output Test Source Power Linearity Test The Operator's Check
A18 system motherboard	No adjustment needed	Front Panel Keypad and RPG Test and A3 Display Test in Chapter 4 The Operator's Check
A19 midplane board	No adjustment needed	None needed
A20 power supply assembly	No adjustment needed	None needed
A21 CPU board	No adjustment needed	The Operator's Check
A22 GPIB board	No adjustment needed	None needed
A23 test set motherboard	Reinstall the serial number. (Refer to "Installing or Changing a Serial Number" in Chapter 8.) Re-enable all hardware options. (Refer to "Option Entitlement Certificate" in Chapter 8.)	The Operator's Check
A24 IF multiplexer board	IF Gain Adjustment Receiver Adjustment	The Operator's Check
A25 HMA26.5	EE Default Adjustment: LO Drive only EE Default Adjustment: LO Drive Noise Figure only (Option 029 equipped PNA) IF Gain Adjustment Receiver Characterization Receiver Adjustment	Noise Floor Test Receiver Compression Test Dynamic Accuracy Test
A26 splitter	IF Gain Adjustment Receiver Characterization Receiver Adjustment	Noise Floor Test Receiver Compression Test Dynamic Accuracy Test

Table 7-2 Related Service Procedures (Continued)

Replaced Assembly	Adjustments and Other Procedures	Verification, Performance, and Other Tests and Procedures
A27 and A28 mixer bricks	IF Gain Adjustment Receiver Characterization Receiver Adjustment	Noise Floor Test Receiver Compression Test Dynamic Accuracy Test
A29–A32 receiver couplers	Source Adjustment Receiver Adjustment	Source Maximum Power Output Test Calibration Coefficients Test
A33–A36 test port couplers	Source Adjustment Receiver Adjustment	Source Maximum Power Output Test Calibration Coefficients Test
A37 reference mixer switch	No adjustment needed	The Operator’s Check
A38–A41 source step attenuators	Source Adjustment Receiver Adjustment	Source Maximum Power Output Test Calibration Coefficients Test
A42–A45 bias tees	Source Adjustment Receiver Adjustment	Source Maximum Power Output Test Calibration Coefficients Test
A46–A49 receiver step attenuators	Receiver Adjustment	Noise Floor Test Receiver Compression Test Dynamic Accuracy Test Calibration Coefficients Test
A55 solid state drive	Restore previously saved receiver calibration data ^a (or perform Receiver Adjustment)	Read and write to the drive
B1 fan	No adjustment needed	Check for fan operation
Battery	No adjustment needed	None

a. If a backup copy of receiver calibration data from the faulty disk drive is available, it can be copied to the new disk drive. If not, new data must be generated by performing the Receiver Adjustment

8 General Purpose Maintenance Procedures

Information in This Chapter

Chapter Eight at-a-Glance

Section Title	Summary of Content	Start Page
Error Terms	How to use error terms as a preventive maintenance and troubleshooting tool.	page 8-3
Option Enable Utility	How to use the option enable utility to: <ul style="list-style-type: none">• enable options that have been added to your analyzer,• repair lost or damaged option data,• install or change a serial number.	page 8-13
Firmware Upgrades	How to check your analyzer's current firmware revision and where to locate firmware upgrades.	page 8-17
Operating System Recovery	Where to find the information on recovering from a damaged operating system.	page 8-18
Correction Constants	How to store correction constants after making adjustments to your analyzer.	page 8-19

Conventions Used for Hardkeys, Softkeys, and Menu Items

The following conventions are used in this document:

Hardkey

This represents a "hardkey", a key that is physically located on the instrument.

Softkey

This represents a "softkey", a key whose label is determined by the instrument firmware.

Menu Item

This represents an item in a drop-down or pop-up menu.

Error Terms

Using Error Terms as a Diagnostic Tool

By examining error terms, you can monitor system performance for preventive maintenance and troubleshooting purposes.

The the most common causes of error term anomalies are:

- calibration kit devices
- cables
- adapters and accessories
- the assemblies from the signal separation group of the analyzer

These items also affect the magnitude and shape of the error terms. For highest measurement accuracy, make sure of the following:

- Use proper connector care. Connectors must be clean, gaged, and within specification.
- Use proper connection technique during measurement and calibration. For information on connection technique and on cleaning and gaging connectors, refer to [“Review the Principles of Connector Care” on page 3-5](#) or to the calibration kit’s user’s and service guide.

Preventive Maintenance

If you print or plot the error terms at set intervals (weekly, monthly and so forth), you can compare current error terms to these records. A stable system should generate repeatable error terms over long intervals, (for example, six months). Look for the following:

- A long-term trend often reflects drift, connector and cable wear, or gradual degradation, indicating the need for further investigation and preventive maintenance. Yet, the system may still conform to specifications. The cure is often as simple as cleaning and gaging connectors and cables.
- A sudden shift in error terms may indicate the need for troubleshooting.

Troubleshooting

You can use the error terms as a tool to isolate faulty assemblies in the signal separation group of your analyzer. You can compare the current values to preventive maintenance records or to the typical values listed in [Table 8-5 on page 8-10](#).

To find assemblies related to error term failures, refer to error term descriptions in [“Error Term Data” on page 8-10](#). Each description lists common assemblies related to each error term. Identify the assembly and refer to [Chapter 4, “Troubleshooting.”](#)

NOTE Always suspect calibration devices, cables, or improper connector maintenance as the primary cause of an error term anomaly.

Performing Measurement Calibration

A calibration must be performed to allow the analyzer to calculate the error terms before they can be used

as a tool:

CAUTION Perform the following procedure only at a static-safe workstation, and wear a grounded wrist strap.

This is important. If not properly protected against, electrostatic discharge can seriously damage your analyzer, resulting in costly repair.

To reduce the chance of electrostatic discharge, follow all of the recommendations outlined in **“Electrostatic Discharge Protection”** on page 1-6, when performing the following calibration.

1. Connect a type-N cable to Port 2.
2. Perform a full 2-port calibration, **FULL SOLT 2-Port**. Refer to embedded help in the analyzer if necessary.

Using Flowgraphs to Identify Error Terms

Flowgraphs are a graphical representation of signal flow through the measurement path. The flowgraphs in **Figure 8-1**, **Figure 8-2**, **Figure 8-3**, and **Figure 8-4** illustrate the error terms associated with measurement calibration for 1-port, 2-port, 3-port, and 4-port configurations respectively.

Figure 8-1 Flowgraph of One-Port Error Terms for Port 1

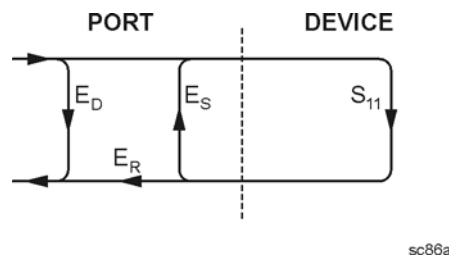

where:

E = Error term

Subscript:

D = Directivity

S = Source Match

R = Reflection Tracking

The error terms are the same for a one port measurement on Port 2 (S_{22}).

Figure 8-2 Flowgraph of Two-Port Error Terms

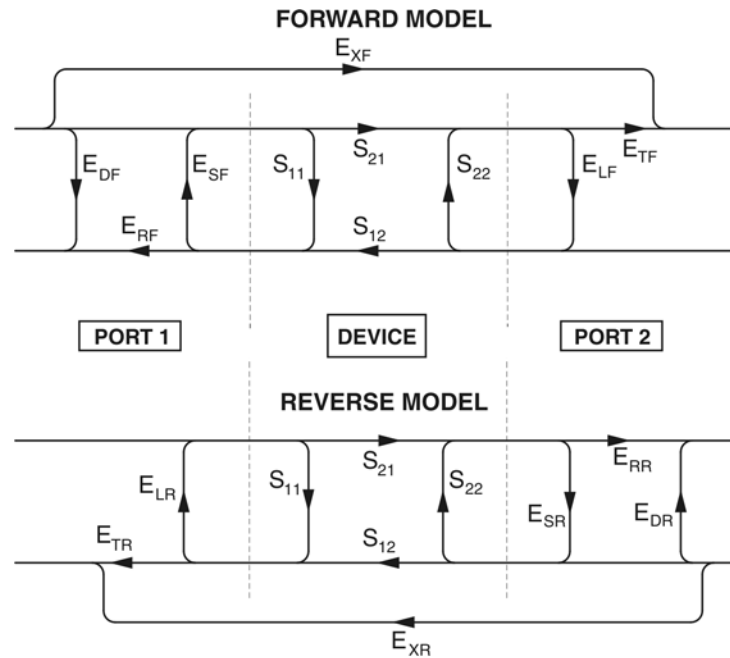

sc87a.cdr

where:

E = error term

1st Subscript:

D = Directivity

S = Source Match

R = Reflection Tracking

X = Crosstalk (Isolation)

L = Load Match

T = Transmission Tracking

2nd Subscript:

F = forward measurement (Ports 1 to Port 2)

R = reverse measurement (Ports 2 to Port 1)

Figure 8-3 Flowgraph of Three-Port Error Terms

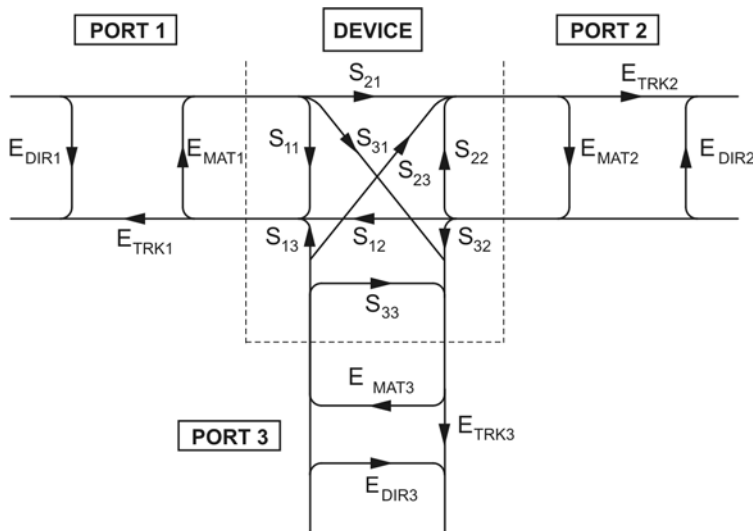

sz348a

where:

- E = error term
- DIR = Directivity
- MAT = Forward Source Match and Reverse Load Match
- TRK = Forward Reflection Tracking and Reverse Transmission Tracking

For the case of a full 3-port calibration, port 1 has three Match error terms:

- S11 source match
 - S12 load match
 - S13 load match
- and three Tracking error terms:
- S11 reflection tracking
 - S12 transmission tracking
 - S13 transmission tracking

There are six isolation terms not shown.

Figure 8-4 Flowgraph of Four-Port Error Terms

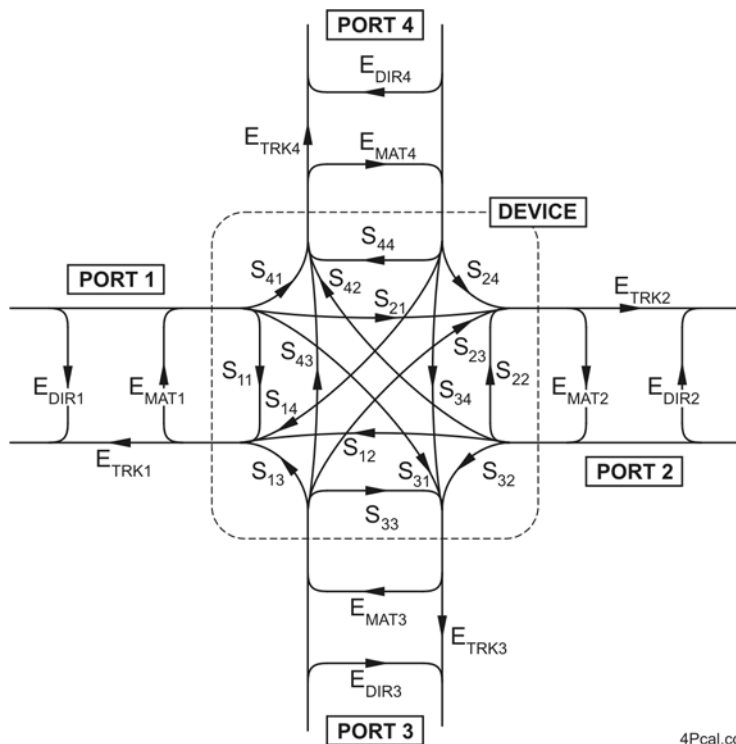

where:

E = error term

DIR = Directivity

MAT = Forward Source Match and Reverse Load Match

TRK = Forward Reflection Tracking and Reverse Transmission Tracking

For the case of a full 4-port calibration, port 1 has four Match error terms:

S11 source match

S12 load match

S13 load match

S14 load match

and four Tracking error terms:

S11 reflection tracking

S12 transmission tracking

S13 transmission tracking

S12 transmission tracking

There are eight isolation (crosstalk) terms not shown.

Accessing Error Terms

Error terms can be accessed either manually or programmatically:

Manually

- “Front Panel Access to Error Terms” on page 8-8

Programmatically

- “GPIB Access to Error Terms” on page 8-9
- “COM/DCOM Access to Error Terms” on page 8-9

Manual Access to Error Terms

Front Panel Access to Error Terms

NOTE Ensure that calibration correction is active by pressing RESPONSE **Cal** and verifying that the softkey label reads **Correction ON/off**. If not, press the **Correction on/OFF** key and it will toggle to read **Correction ON/off**.

To access the error terms from the front panel, perform the following steps:

1. Press RESPONSE **Cal**, then **Manage Cals**. Verify that **Cal Set Viewer ON/off** is **ON**. If not, press the softkey to toggle it **ON**.
The **Cal Set Viewer** toolbar appears directly above the trace window.
2. In the **Cal Set** list, select the desired cal set.
3. Click the **Standards** or **Error Terms** button to view the raw measurement data from the standard or the corrected error term data.
4. In the **Standard** or **Error Terms** list, select the standard or error terms to view. Click the **Enable** check box to enable the selection.
5. Compare the displayed measurement trace to previously measured data or to the uncorrected performance specifications listed in [Table 8-5 on page 8-10](#).
6. Print numerical data or print a plot of the measurement results.

Programmatic Access to Error Terms

GPIB Access to Error Terms. You can access error terms by way of GPIB with Standard Commands for Programmable Instruments (SCPI).

For more information on GPIB and SCPI, refer to the embedded help in the analyzer. Type in keyword “errors, systematic” in the index.

COM/DCOM Access to Error Terms. You can access error terms by way of Component Object Model (COM) or Distributed Component Object Model (DCOM) software architecture.

For more information on COM and DCOM, refer to the embedded help in the analyzer. Type in keyword “errors, systematic” in the index.

Error Term Data

The error term descriptions in this section include the following information:

- a table of the error terms
- description and significance of each error term
- measurements affected by each error term
- typical cause of failure for each error term

The same description applies to both the forward (F) and reverse (R) terms.

IMPORTANT Data are listed here as a convenience only. Detailed instrument specifications are listed in the embedded help in the network analyzer.

If Error Terms Seem Worse than Expected

To verify that the system still conforms to specifications, perform a system verification. Refer to [Chapter 3, "Tests and Adjustments"](#).

Figure 8-5 Error Term Data^a

Parameter (All options, all ports)	Frequency Range					
	10 MHz to 50 MHz	50 MHz to 3.2 GHz	3.2 GHz to 10 GHz	10 GHz to 16 GHz	16 GHz to 24 GHz	24 GHz to 26.5 GHz
Directivity	16 dBm	24 dBm	23 dBm	16 dBm	16 dBm	16 dBm
Source Match	11 dBm	18 dBm	14 dBm	12 dBm	10 dBm	8 dBm
Load Match	11 dBm	17 dBm	13 dBm	10 dBm	9 dBm	8 dBm
	10 MHz to 50 MHz	50 MHz to 100 MHz	100 MHz to 500 MHz	500 MHz to 3.2 GHz	3.2 GHz to 20 GHz	20 GHz to 26.5 GHz
Crosstalk ^b	-84 dBm	-90 dBm	-110 dBm	-120 dBm	-122 dBm	-117 dBm

- a. The data in this table are uncorrected system performance. The values apply over an environmental temperature range of 25 °C ±5 °C, with less than 1 °C deviation from the calibration temperature.
- b. All crosstalk values are typical. Measurement conditions: normalized to a thru, measured with two shorts, 10 Hz IF bandwidth, averaging factor of 8, alternate mode, source power set to the lesser of the maximum power out or the maximum receiver power.

Directivity (E_{DF} and E_{DR})

E_{DF} and E_{DR} are the uncorrected forward and reverse directivity error terms of the system. The directivity error of the test port is determined by measuring the S_{11} and S_{22} reflection of the calibration kit load. The load has a much better return loss specification than does the uncorrected test port. Therefore, any power detected from this measurement is assumed to be from directivity error.

The measurements most affected by directivity errors are measurements of low reflection devices.

Typical Cause of Failure. The *calibration kit load* is the most common cause of directivity specification failure.

If the load has been gaged and its performance independently verified, suspect the analyzer *test port coupler*.

To troubleshoot, refer to [“Checking the Signal Separation Group” on page 4-35](#).

Source Match (E_{SF} and E_{SR})

E_{SF} and E_{SR} are the forward and reverse uncorrected source match terms of the driven port. They are obtained by measuring the reflection (S_{11} , S_{22}) of an open, and a short that are connected directly to the ports. Source match is a measure of the match of the coupler, as well as the match between all components from the source to the output port.

The measurements most affected by source match errors are reflection and transmission measurements of highly reflective DUTs.

Typical Cause of Failure. The *calibration kit open or short* is the most common cause of source match specification failure.

If the open or short performance has been independently verified, then suspect the analyzer *switch splitter, step attenuator, or coupler*.

To troubleshoot, refer to [“Checking the Signal Separation Group” on page 4-35](#).

Load Match (E_{LF} and E_{LR})

Load match is a measure of the impedance match of the test port that terminates the output of a 2-port device. The match of test port cables is included in this response. Load match error terms are characterized by measuring the S_{11} and S_{22} responses of a “thru” configuration during the calibration procedure.

The measurements most affected by load match errors are all transmission measurements, and reflection measurements of a low insertion loss two-port device, such as an airline.

Typical Cause of Failure. The *calibration kit load or a bad “thru” cable* is the most common cause of load match specification failure.

If the load and cable performance are independently verified, then suspect the analyzer *test port coupler, step attenuator, or the test receiver* at the bad port.

To troubleshoot, refer to [“Checking the Receiver Group” on page 4-39](#) or to [“Checking the Signal Separation Group” on page 4-35](#).

Isolation (Crosstalk) (E_{XF} and E_{XR})

Isolation, or crosstalk, is the uncorrected forward and reverse isolation error terms that represent leakage between the test ports and the signal paths. The isolation error terms are characterized by measuring transmission (S_{21} , S_{12}) with loads attached to both ports during the measurement calibration. Isolation errors affect transmission measurements primarily where the measured signal level is very low.

The measurements most affected by isolation error terms are DUTs with large insertion loss. Since these terms are low in magnitude, they are usually noisy (not very repeatable).

Typical Cause of Failure. A *loose cable connection or leakage between components* in the test set are the most likely cause of isolation problems.

After verifying the cable and its connections, suspect the analyzer *switch splitter, step attenuator, coupler, or receivers, and associated cabling*.

To troubleshoot, refer to [“Checking the Receiver Group” on page 4-39](#) or to [“Checking the Signal Separation Group” on page 4-35](#).

Option Enable Utility

Accessing the Option Enable Utility

To start the option enable utility:

- Press UTILITY **System** , then **Service** , then **Option Enable** .
- A dialog box similar to the one illustrated in **Figure 8-6** is displayed.

Figure 8-6 Option Enable Dialog Box

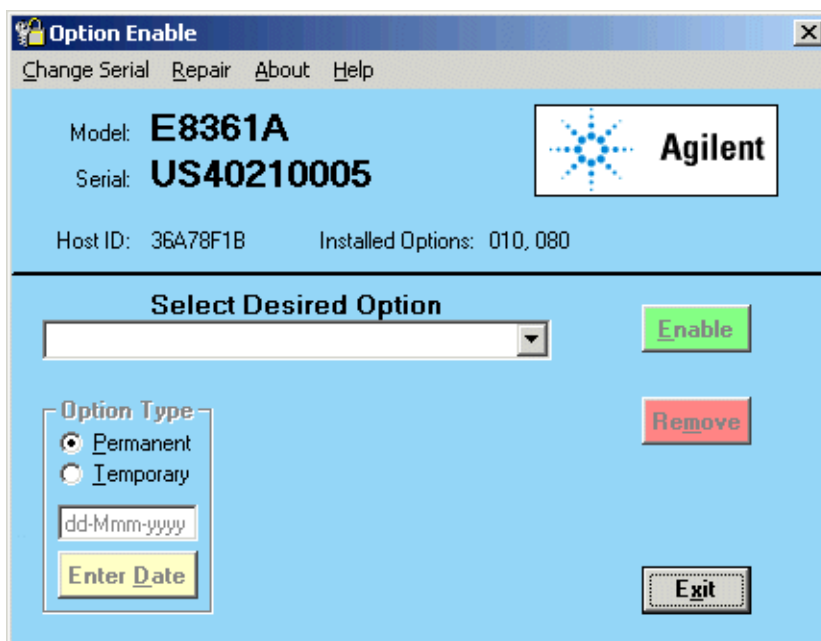

Option Entitlement Certificate

If you have received an “Option Entitlement Certificate”, follow the instructions on the certificate, under “HOW TO USE THIS CERTIFICATE:”, to obtain license key(s) for the option(s) listed on the certificate. See the important note below.

NOTE When upgrading from one model number to another, a new option entitlement certificate will be issued. When this certificate is redeemed for a license key, the automated system will ask for the instrument's Host ID. Be sure to use the new Host ID that is associated with the new model number. Using the current Host ID will cause a license to be generated that will not work with the instrument. To determine the new Host ID, use the utility at the below listed web site with the new model number.

<http://na.support.keysight.com/pna/upgrades.html>

Enabling or Removing Options

There are two types of options:

- **Hardware:** Hardware options involve adding additional hardware to the analyzer. After the proper hardware has been installed in the analyzer, the option can be enabled using the option enable utility. It is necessary to re-enable all installed hardware options if the test set motherboard is replaced.
- **Software:** Software options add features or functionality to the analyzer without the need for additional hardware. These options are enabled using the option enable utility and require a special license key.

NOTE Some applications require a license key that is provided by Keysight. If you do not have the required license key, contact Keysight for assistance. Refer to [“Contacting Keysight” on page 2-8](#).

It is necessary to backup all installed software options if the frequency reference board is replaced.

To enable or remove an option:

1. Start the option enable utility. Refer to [“Accessing the Option Enable Utility” on page 8-13](#).
2. Click the arrow in the **Select Desired Option** box. A list of available options, similar to the list below, will appear.
 - 020 - Add IF inputs
 - 021 - Pulse Modulator on Source 1
 - 022 - Pulse Modulator on Source 2
 - 025 - 4-Receiver Pulse Generator
 - 086 - Gain Compression Application
 - 087- IMD Measurements
 - 219 - Src/Rcvr Atten & Bias Tees 2-Port
 - 419 - Src/Rcvr Atten & Bias Tees 4-Port
 - ??? - Enter Unlisted Option
3. Click on the option that you wish to either enable or remove, and then click **Enable** or **Remove**, whichever is appropriate.
4. If the desired option is not available in the list, select **??? - Enter Unlisted Option**. A dialog box appears that will allow you to enter the option number. Enter the option number and follow the instructions on the display.

Repairing and Recovering Option Data

License, option, and model number data are stored in an EEPROM on the frequency reference board and written into the gen.lic file on the solid state drive. If the data stored in either of these items is lost, it can be recovered from the other item.

If the data on both the solid state drive and the frequency reference board is lost, it can not be recovered. Contact Keysight for assistance. Refer to [“Contacting Keysight” on page 2-8](#).

Recovery of Data After Repair

- If the frequency reference board is replaced, use the **Repair** selection to recover data that has been lost as a result of the repair:
 1. Select **Repair** from the **Option Enable** menu bar (see [Figure 8-6 on page 8-13](#)).
 2. Click the **Freq Ref board has been replaced** check box.
 3. Click **Begin Repair**. The data is written from the gen.lic file into the EEPROM.
- If the solid state drive is replaced, a new gen.lic file is automatically created when the **Network Analyzer** application starts, by retrieving the data from the EEPROM.

Recovery of Data if Option or Model Numbers are Incorrect

If the analyzer option or model numbers are not listed correctly on the analyzer display, in either the Option Enable Dialog Box or the About Network Analyzer display, you should regenerate the options license file, gen.lic:

1. Exit the **Network Analyzer** application.
2. Remove (or rename) the existing gen.lic file:
 - a. Open **Windows Explorer** and navigate to C:\Program Files\Keysight\Network Analyzer.
 - b. Delete (or rename) gen.lic.
3. Exit the **Windows Explorer** application.
4. Open the **Network Analyzer** application. The application will generate a new gen.lic file when it starts.
5. Check the option listing:
 - a. Press UTILITY **System** , then **Service** , then **Option Enable** or
 - b. Press UTILITY **System** , then **Help** , then **About NA...** .
6. If the options are still not listed correctly, contact Keysight for assistance. Refer to [“Contacting Keysight” on page 2-8](#).

Installing or Changing a Serial Number

It is necessary to reinstall the instrument serial number if the test set motherboard is replaced.

IMPORTANT Use extreme care when entering the serial number, as only one attempt is allowed.

1. To change a serial number, select **Change Serial** from the **Option Enable** menu bar (see [Figure 8-6 on page 8-13](#)). The current serial number is displayed. If no serial number has previously been entered, the word "NONE" will be displayed.
2. VERY CAREFULLY, type the new serial number into the space provided and then click **Change**.
3. If an error is made in entering the serial number, obtain a clear code from Keysight, enter the clear code in the space provided and click **CLEAR**. The correct serial number can then be entered.

NOTE To change an incorrect serial number, a clear-code password is required. Contact Keysight to obtain the clear-code. Refer to ["Contacting Keysight" on page 2-8](#).

Firmware Upgrades

How to Check the Current Firmware Version

1. Press UTILITY **System** , then **Help** , then **About NA...** .

A dialog box showing the current installed Application Code Version is displayed.

2. To determine if a firmware update is available, proceed to **“Downloading from the Internet.”**

Downloading from the Internet

If your network analyzer is connected to the Internet, there are two methods available for checking the availability of, and downloading, new firmware:

- Download directly from: <http://www.keysight.com/find/pna>. (Select your analyzer’s model number in this web site to view available upgrades.)
- Press UTILITY **System** , then **Service** , then **AgileUpdate** .

AgileUpdate compares the firmware revision currently installed in your network analyzer to the latest version available and assists you in downloading and installing the most recent version.

Operating System Recovery

Recovering from Solid State Drive Problems

If you suspect that you have a solid state drive problem, go to the “Hard Drive Recovery” link on the Keysight PNA Series: Service & Support Home Page on the Internet.

The URL for the Keysight PNA Series: Service & Support Home Page is:

<http://na.support.keysight.com/pna/>

The URL for the Hard Drive Recovery page is:

<http://na.support.keysight.com/pna/hdrecovery.html>

Correction Constants

The analyzer stores many correction constants in non-volatile EEPROM memory. These constants enable the analyzer to produce accurate, leveled source signals and receive clean test signals.

Storing Correction Constants

After performing any adjustment listed on [page 3-39](#) in this manual, store the correction constants to a backup file on the analyzer solid state drive by performing these steps:

- Navigate to the EEPROM Backup Utility, located at:
C:\Program Files\Keysight\Network Analyzer\Service\eebackup.exe
- Run the program.
- Click Backup EEPROM.
- Click Exit when the program has finished.

Numerics

13.5 GHz LO synthesizer board

- operation, 5-11
- part number, 6-16
- removal and replacement
 - illustrated, 7-15
 - procedure, 7-14
- troubleshooting, 4-31

13.5 GHz source 1 synthesizer board

- illustrated, 6-18
- operation, 5-11
- part number, 6-16
- removal and replacement
 - illustrated, 7-15
 - procedure, 7-14
- troubleshooting, 4-33

13.5 GHz source 2 synthesizer board

- illustrated, 6-18
- operation, 5-11
- part number, 6-16
- removal and replacement
 - illustrated, 7-15
 - procedure, 7-14
- troubleshooting, 4-33

26.5 GHz source 1 board

- illustrated, 6-18
- part number, 6-16
- removal and replacement
 - illustrated, 7-15
 - procedure, 7-14
- troubleshooting, 4-33

26.5 GHz source 2 board

- illustrated, 6-18
- part number, 6-16
- removal and replacement
 - illustrated, 7-15
 - procedure, 7-14
- troubleshooting, 4-33

A

A receiver

- troubleshooting, 4-26
- typical power output, 4-36

A trace

- troubleshooting, 4-26, 4-29

A1 front panel interface board

- part number, 6-12
- removal and replacement
 - illustrated, 7-11
 - procedure, 7-10
- troubleshooting, 4-12, 4-13

A10 26.5 GHz source 2 board

- illustrated, 6-18
- operation, 5-11
- part number, 6-16
- removal and replacement
 - illustrated, 7-15

- procedure, 7-14
- troubleshooting, 4-33

A12 doubler

- illustrated, 6-18
- part number, 6-16
- removal and replacement
 - illustrated, 7-15
 - procedure, 7-14

A13 doubler

- illustrated, 6-18
- part number, 6-16
- removal and replacement
 - illustrated, 7-15
 - procedure, 7-14

A14 frequency reference board

- illustrated, 6-18
- operation, 5-12
- part number, 6-16
- removal and replacement
 - illustrated, 7-15
- troubleshooting, 4-31

A15 13.5 GHz LO synthesizer board

- illustrated, 6-18
- operation, 5-11
- part number, 6-16
- removal and replacement
 - illustrated, 7-15
 - procedure, 7-14
- troubleshooting, 4-31

A16 SPAM board

- illustrated, 6-18
- operation
 - analog, 5-22
 - digital, 5-29
- part number, 6-16
- removal and replacement
 - illustrated, 7-15
 - procedure, 7-14
- troubleshooting, 4-41

A17 13.5 GHz source 2 synthesizer board

- illustrated, 6-18
- operation, 5-11
- part number, 6-16
- removal and replacement
 - illustrated, 7-15
 - procedure, 7-14
- troubleshooting, 4-33

A18 system motherboard

- illustrated, 6-18
- operation, 5-28
- part number, 6-16
- removal and replacement
 - procedure, 7-16

A19 midplane board

- illustrated, 6-18
- part number, 6-16
- removal and replacement
 - illustrated, 7-19

- procedure, 7-18

A2 USB board

- part number, 6-12
- removal and replacement
 - illustrated, 7-11
 - procedure, 7-10
- troubleshooting, 4-13

A20 power supply assembly

- illustrated, 6-18
- operation, 5-31
- part number, 6-16
- removal and replacement
 - illustrated, 7-21
 - procedure, 7-20
- troubleshooting, 4-7

A21 CPU board

- illustrated, 6-18
- operation, 5-29
- part number, 6-16
- removal and replacement
 - illustrated, 7-23
 - procedure, 7-22
- troubleshooting, 4-17

A22 GPIB board

- illustrated, 6-18
- part number, 6-16
- removal and replacement
 - illustrated, 7-25
 - procedure, 7-24

A23 test set motherboard

- illustrated, 6-23, 6-29, 6-35, 6-41, 6-47, 6-53, 6-59, 6-65, 6-71, 6-79
- operation, 5-13
- part number, 6-22, 6-28, 6-34, 6-46, 6-52, 6-58, 6-64, 6-70, 6-78
- removal and replacement
 - illustrated, 7-27
 - procedure, 7-26

A24 IF multiplexer board

- illustrated, 6-23, 6-29, 6-35, 6-41, 6-47, 6-53, 6-59, 6-65, 6-71, 6-79
- operation, 5-22
- part number, 6-22, 6-28, 6-34, 6-46, 6-52, 6-58, 6-64, 6-70, 6-78
- removal and replacement
 - illustrated, 7-29
 - procedure, 7-28
- troubleshooting, 4-41

A25 HMA26.5

- illustrated, 6-23, 6-29, 6-35, 6-41, 6-47, 6-53, 6-59, 6-65, 6-71, 6-79
- operation, 5-12, 5-18
- part number, 6-22, 6-28, 6-34, 6-46, 6-52, 6-58, 6-64, 6-70, 6-78
- removal and replacement
 - illustrated, 7-31
 - procedure, 7-30
- troubleshooting, 4-32

- A26 splitter**
 - illustrated, 6-53, 6-59, 6-65, 6-71, 6-79
 - part number, 6-52, 6-58, 6-64, 6-70, 6-78
 - removal and replacement
 - illustrated, 7-33
 - procedure, 7-32
 - troubleshooting, 4-32
- A27 mixer brick**
 - illustrated, 6-23, 6-29, 6-35, 6-41, 6-47, 6-53, 6-59, 6-65, 6-71, 6-79
 - operation, 5-21
 - part number, 6-22, 6-28, 6-34, 6-46, 6-52, 6-58, 6-64, 6-70, 6-78
 - removal and replacement
 - illustrated, 7-35
 - procedure, 7-34
 - troubleshooting, 4-40
- A28 mixer brick**
 - illustrated, 6-53, 6-59, 6-65, 6-71, 6-79
 - operation, 5-21
 - part number, 6-52, 6-58, 6-64, 6-70, 6-78
 - removal and replacement
 - illustrated, 7-35
 - procedure, 7-34
 - troubleshooting, 4-40
- A29 test port 1 receiver coupler**
 - illustrated, 6-23, 6-29, 6-35, 6-41, 6-47, 6-53, 6-59, 6-65, 6-71, 6-79
 - part number, 6-22, 6-28, 6-34, 6-46, 6-52, 6-58, 6-64, 6-70, 6-78
 - removal and replacement
 - illustrated, 7-37
- A3 display assembly**
 - operation, 5-28
 - part number, 6-12
 - removal and replacement
 - illustrated, 7-12, 7-13
 - procedure, 7-12
 - troubleshooting, 4-12, 4-13
- A30 test port 3 receiver coupler**
 - illustrated, 6-53, 6-59, 6-65, 6-71, 6-79
 - part number, 6-52, 6-58, 6-64, 6-70, 6-78
 - removal and replacement
 - illustrated, 7-37
 - procedure, 7-36
 - troubleshooting, 4-37
- A31 test port 4 receiver coupler**
 - illustrated, 6-53, 6-59, 6-65, 6-71, 6-79
 - part number, 6-52, 6-58, 6-64, 6-70, 6-78
 - removal and replacement
 - illustrated, 7-37
 - procedure, 7-36
 - troubleshooting, 4-37
- A32 test port 2 receiver coupler**
 - illustrated, 6-23, 6-29, 6-35, 6-41, 6-47, 6-53, 6-59, 6-65, 6-71, 6-79
 - part number, 6-22, 6-28, 6-34, 6-46, 6-52, 6-58, 6-64, 6-70, 6-78
 - removal and replacement
 - illustrated, 7-37
 - procedure, 7-36
 - troubleshooting, 4-37
- A33 test port 1 coupler**
 - illustrated, 6-23, 6-29, 6-35, 6-41, 6-47, 6-53, 6-59, 6-65, 6-71, 6-79
 - operation, 5-18
 - part number, 6-22, 6-28, 6-34, 6-46, 6-52, 6-58, 6-64, 6-70, 6-78
 - removal and replacement
 - illustrated, 7-39
 - procedure, 7-38
 - troubleshooting, 4-37
- A34 test port 3 coupler**
 - illustrated, 6-53, 6-59, 6-65, 6-71, 6-79
 - operation, 5-18
 - part number, 6-52, 6-58, 6-64, 6-70, 6-78
 - removal and replacement
 - procedure, 7-38, 7-39
 - troubleshooting, 4-37
- A35 test port 4 coupler**
 - illustrated, 6-53, 6-59, 6-65, 6-71, 6-79
 - operation, 5-18
 - part number, 6-52, 6-58, 6-64, 6-70, 6-78
 - removal and replacement
 - procedure, 7-38, 7-39
 - troubleshooting, 4-37
- A36 test port 2 coupler**
 - illustrated, 6-23, 6-29, 6-35, 6-41, 6-47, 6-53, 6-59, 6-65, 6-71, 6-79
 - operation, 5-18
 - part number, 6-22, 6-28, 6-34, 6-46, 6-52, 6-58, 6-64, 6-70, 6-78
 - removal and replacement
 - procedure, 7-38, 7-39
 - troubleshooting, 4-37
- A37 reference mixer switch**
 - illustrated, 6-23, 6-29, 6-35, 6-41, 6-47, 6-53, 6-59, 6-65, 6-71, 6-79
 - operation, 5-21
 - part number, 6-28, 6-34, 6-46, 6-52, 6-58, 6-64, 6-70, 6-78
 - removal and replacement
 - illustrated, 7-41
 - procedure, 7-40
 - troubleshooting, 4-40
- A38 test port 1 source step attenuator**
 - illustrated, 6-41, 6-47, 6-71, 6-79
 - part number, 6-46, 6-70, 6-78
 - removal and replacement
 - illustrated, 7-43
- A39 test port 3 source step attenuator**
 - illustrated, 6-71, 6-79
 - part number, 6-70, 6-78
 - removal and replacement
 - illustrated, 7-43
 - procedure, 7-42
 - troubleshooting, 4-37
- A4 13.5 GHz source 1 synthesizer board**
 - illustrated, 6-18
 - operation, 5-11
 - part number, 6-16
 - removal and replacement
 - illustrated, 7-15
 - procedure, 7-14
 - troubleshooting, 4-33
- A40 test port 4 source step attenuator**
 - illustrated, 6-71, 6-79
 - part number, 6-70, 6-78
 - removal and replacement
 - illustrated, 7-43
 - procedure, 7-42
 - troubleshooting, 4-37
- A41 test port 2 source step attenuator**
 - illustrated, 6-41, 6-47, 6-71, 6-79
 - part number, 6-46, 6-70, 6-78
 - removal and replacement
 - illustrated, 7-43
 - procedure, 7-42
 - troubleshooting, 4-37
- A42 test port 1 bias tee**
 - illustrated, 6-47, 6-79
 - part number, 6-46, 6-78
 - removal and replacement
 - illustrated, 7-43, 7-45
 - procedure, 7-42, 7-44
 - troubleshooting, 4-37
- A43 test port 3 bias tee**
 - illustrated, 6-79
 - part number, 6-78
 - removal and replacement
 - illustrated, 7-43, 7-45
 - procedure, 7-42, 7-44
 - troubleshooting, 4-37
- A44 test port 4 bias tee**
 - illustrated, 6-79
 - part number, 6-78
 - removal and replacement
 - illustrated, 7-43, 7-45
 - procedure, 7-42, 7-44
 - troubleshooting, 4-37
- A45 test port 2 bias tee**
 - illustrated, 6-47, 6-79
 - part number, 6-46, 6-78
 - removal and replacement
 - illustrated, 7-43, 7-45
 - procedure, 7-42, 7-44

- troubleshooting, 4-37
- A46 test port 1 receiver step attenuator**
 - illustrated, 6-41, 6-47, 6-71, 6-79
 - operation, 5-21
 - part number, 6-46, 6-70, 6-78
 - removal and replacement
 - illustrated, 7-43
 - procedure, 7-42
 - troubleshooting, 4-41
- A47 test port 3 receiver step attenuator**
 - illustrated, 6-71, 6-79
 - operation, 5-21
 - part number, 6-70, 6-78
 - removal and replacement
 - illustrated, 7-43
 - procedure, 7-42
 - troubleshooting, 4-41
- A48 test port 4 receiver step attenuator**
 - illustrated, 6-71, 6-79
 - operation, 5-21
 - part number, 6-70, 6-78
 - removal and replacement
 - illustrated, 7-43
 - procedure, 7-42
 - troubleshooting, 4-41
- A49 test port 2 receiver step attenuator**
 - illustrated, 6-41, 6-47, 6-71, 6-79
 - operation, 5-21
 - part number, 6-46, 6-70, 6-78
 - removal and replacement
 - illustrated, 7-43
 - procedure, 7-42
 - troubleshooting, 4-41
- A5 26.5 GHz source 1 board**
 - illustrated, 6-18
 - operation, 5-11
 - part number, 6-16
 - removal and replacement
 - illustrated, 7-15
 - procedure, 7-14
 - troubleshooting, 4-33
- A55 solid state drive**
 - illustrated, 6-18
 - operation, 5-30
 - part number, 6-16
 - removal and replacement
 - illustrated, 7-47
 - procedure, 7-46
- A7 doubler**
 - illustrated, 6-18
 - part number, 6-16
 - removal and replacement
 - illustrated, 7-15
 - procedure, 7-14
- A8 doubler**
 - illustrated, 6-18
 - part number, 6-16
 - removal and replacement
 - illustrated, 7-15
 - procedure, 7-14
- illustrated, 7-15
- procedure, 7-14
- accessories**
 - analyzer, 2-4
 - in operator's check, 3-10
 - in test port cable checks, 3-12
 - USB
 - part numbers, 6-99
- accuracy**
 - dynamic accuracy test, 3-38
 - frequency test, 3-32
- adapters**
 - required for servicing, 2-6
- adding**
 - options, 8-14
- adjustments**
 - EE default, 3-46
 - frequency
 - at 10 MHz, 3-40
 - IF gain, 3-41
 - receiver calibration, 3-43
 - receiver characterization, 3-46
 - source calibration, 3-42
 - synthesizer bandwidth, 3-41
 - system, 3-1, 3-39
 - getting ready, 3-4
- agile update**
 - downloading firmware from the internet, 8-17
- Agilent**
 - contacting, 2-8
 - support, 2-8
- analyzer**
 - accessories, 2-4
 - block diagram
 - digital control group, 5-27
 - digital processor group, 5-27
 - receiver group, 5-24, 5-25
 - signal separation group, 5-19, 5-20
 - covers
 - illustrated, 6-97
 - part numbers, 6-96
 - removal and replacement, 7-6
 - external replaceable parts
 - illustrated, 6-97
 - part numbers, 6-96
 - feet
 - illustrated, 6-97
 - part numbers, 6-96
 - frequency reference board assembly, 5-12
 - front panel interconnects, 5-28
 - functional groups, 5-4
 - digital control, 5-6
 - digital processing, 5-6
 - power supply, 5-6
 - receiver group, 5-6
 - signal separation, 5-6
 - synthesized source, 5-5
 - internal performance test software, 3-28
 - internal replaceable parts
 - illustrated, 6-95
 - part numbers, 6-94
 - miscellaneous replaceable parts
 - part numbers, 6-98
 - operation
 - 13.5 GHz synthesizer boards, 5-11
 - A7, A8, A12, and A13 doublers, 5-12
 - configurable test set, 5-17
 - CPU board, 5-29
 - data acquisition subgroup, 5-28
 - digital control group, 5-26
 - digital processor group, 5-26
 - display assembly, 5-28
 - front panel display board, 5-28
 - front panel subgroup, 5-28
 - hard disk drive, 5-30
 - IF multiplexer board, 5-22
 - keypad assembly, 5-28
 - MA 26.5, 5-12, 5-18
 - main RAM, 5-29
 - mixer brick, 5-21
 - processing subgroup, 5-28
 - receiver group, 5-21
 - receiver step attenuators, 5-21
 - reference mixer switch, 5-21
 - signal separation group, 5-17
 - source boards, 5-11
 - source group, 5-7
 - SPAM board—analog, 5-22
 - SPAM board—digital, 5-29
 - test port couplers, 5-18
 - test set motherboard, 5-13
 - rear panel
 - interconnects, 5-13, 5-22, 5-30
 - rear panel replaceable parts
 - illustrated, 6-87
 - part numbers, 6-86
 - strap handle
 - illustrated, 6-97
 - part number, 6-96
 - system block diagram, 5-3, 5-4
 - system operation
 - theory of, 5-3
 - upgrades, 2-4
 - warmup time, 3-4
- ANSI/NCSL Z540-1-1994**
 - non-type verification, 3-9
 - verification, 3-8
- assemblies**
 - rebuilt-exchange
 - procedure, 6-5
 - rebuilt-exchange program, 6-5
 - replacement
 - list of procedures, 7-4

- sequence, 6-4
- attenuators**
 - required for servicing, 2-6
- B**
- B receiver**
 - troubleshooting, 4-26
 - typical power output, 4-36
- B trace**
 - troubleshooting, 4-26
- B1 fan**
 - removal and replacement
 - illustrated, 7-53
 - procedure, 7-52
- bandwidth, synthesizer**
 - adjustment, 3-41
- battery**
 - disposal, 1-8
 - illustrated, 6-18
 - part number, 6-16, 6-98
 - removal and replacement
 - illustrated, 7-55
 - procedure, 7-54
- before applying power, 1-3**
- bias tee**
 - See *A42, A43, A44, or A45*
- block diagram**
 - See *analyzer block diagram*
- bottom assembly, Option 200**
 - replaceable parts
 - illustrated, 6-23
 - part numbers, 6-22, 6-34
 - replaceable RF cables
 - illustrated, 6-25
 - part numbers, 6-24
 - replaceable ribbon cables & wire harnesses
 - illustrated, 6-27
 - part numbers, 6-26
- bottom assembly, Option 201**
 - replaceable parts
 - illustrated, 6-29
 - part numbers, 6-28
 - replaceable RF cables
 - illustrated, 6-31
 - part numbers, 6-30
 - replaceable ribbon cables & wire harnesses
 - illustrated, 6-29, 6-33
 - part numbers, 6-28, 6-32
- bottom assembly, Option 210**
 - replaceable parts
 - illustrated, 6-35
 - replaceable RF cables
 - illustrated, 6-37
 - part numbers, 6-36
 - replaceable ribbon cables & wire harnesses
 - illustrated, 6-39
 - part numbers, 6-38
- bottom assembly, Option 217**
 - replaceable parts
 - illustrated, 6-41
 - part numbers, 6-40
 - replaceable RF cables
 - illustrated, 6-43
 - part numbers, 6-42
 - replaceable ribbon cables & wire harnesses
 - illustrated, 6-45
 - part numbers, 6-44
- bottom assembly, Option 219**
 - replaceable parts
 - illustrated, 6-47
 - part numbers, 6-46
 - replaceable RF cables
 - illustrated, 6-49
 - part numbers, 6-48
 - replaceable ribbon cables & wire harnesses
 - illustrated, 6-51
 - part numbers, 6-50
- bottom assembly, Option 400**
 - replaceable parts
 - illustrated, 6-53
 - part numbers, 6-52
 - replaceable RF cables
 - illustrated, 6-55
 - part numbers, 6-54
 - replaceable ribbon cables & wire harnesses
 - illustrated, 6-57
 - part numbers, 6-56
- bottom assembly, Option 401**
 - replaceable parts
 - illustrated, 6-59
 - part numbers, 6-58
 - replaceable RF cables
 - illustrated, 6-61
 - part numbers, 6-60
 - replaceable ribbon cables & wire harnesses
 - illustrated, 6-63
 - part numbers, 6-62
- bottom assembly, Option 410**
 - replaceable parts
 - illustrated, 6-65
 - part numbers, 6-64
 - replaceable RF cables
 - illustrated, 6-67
 - part numbers, 6-66
 - replaceable ribbon cables & wire harnesses
 - illustrated, 6-69
 - part numbers, 6-68
- bottom assembly, Option 417**
 - replaceable parts
 - illustrated, 6-71
 - part numbers, 6-70
 - replaceable RF cables
 - illustrated, 6-73, 6-75
 - part numbers, 6-72, 6-74
 - replaceable ribbon cables & wire harnesses
 - illustrated, 6-77
 - part numbers, 6-76
- bottom assembly, Option 419**
 - replaceable parts
 - illustrated, 6-79
 - part numbers, 6-78
 - replaceable RF cables
 - illustrated, 6-81, 6-83
 - part numbers, 6-80, 6-82
 - replaceable ribbon cables & wire harnesses
 - illustrated, 6-85
 - part numbers, 6-84
- broadband failure, 4-30**
- C**
- C receiver**
 - troubleshooting, 4-26
 - typical power output, 4-36
- C trace**
 - troubleshooting, 4-26
- cable**
 - GPIO**
 - part numbers, 6-98
 - required for servicing, 2-6
 - substitution, 3-23
 - test port
 - checks, 3-10, 3-12, 3-13, 3-14, 3-15, 3-17
 - connector repeatability failure, 3-18
 - insertion loss failure, 3-14
 - magnitude and phase stability failure, 3-16
 - return loss failure, 3-13
- cables, flexible**
 - See *top assembly*
- cables, RF**
 - See *bottom assembly, Option xxx*
- cables, ribbon**
 - See *bottom assembly, Option xxx*
- cables, wire harnesses**
 - See *bottom assembly, Option xxx*
- calibration**
 - certificate of, 3-7
 - coefficients test, 3-37
 - kits, 2-6, 3-6
 - substitution, 3-23
 - measurement, 8-3
 - receiver, 3-43

- source, 3-42
 - caution**, 1-3
 - CE mark**, 1-7
 - certificate of calibration**, 3-7
 - changing**
 - a serial number, 8-16
 - characterization, receiver**
 - adjustment, 3-46
 - checks**
 - cable**
 - connector repeatability, failure of, 3-18
 - insertion loss, failure of, 3-14
 - magnitude and phase stability, failure of, 3-16
 - return loss, failure of, 3-13
 - test port cables, 3-10, 3-12
 - operator's, 3-10
 - accessories used in, 3-10
 - description of, 3-10
 - dialog box, 3-11
 - failure of, 3-11
 - performing, 3-10
 - preliminary, 3-10
 - system, 3-1
 - getting ready, 3-4
 - test port cable
 - accessories used in, 3-12
 - connector repeatability, 3-17
 - insertion loss, 3-14
 - magnitude and phase stability, 3-15
 - performing, 3-12
 - return loss, 3-13
 - COM**, 8-9
 - compression test, receiver**, 3-34
 - configurable test set**
 - operation, 5-17
 - configuration**
 - configurable test set, 5-17
 - high dynamic range measurement, 5-18
 - normal configuration measurement, 5-17
 - connectors**
 - care of, 3-5
 - front panel, 5-28
 - rear panel, 5-13, 5-22, 5-30
 - Display, 5-30
 - EXT 10 MHz REF IN, 5-13
 - EXT 10 MHz REF OUT, 5-13
 - GPIB, 5-30
 - HANDLER I/O, 5-13, 5-15
 - PULSE I/O, 5-23
 - PWR I/O, 5-16
 - TEST SET I/O, 5-13, 5-14
 - USB, 5-30
 - VGA, 5-30
 - repeatability check
 - failure of, 3-18
 - of test port cables, 3-17
 - constants**
 - correction, 8-19
 - contacting Agilent**, 2-8
 - controllers**
 - troubleshooting with, 4-18
 - correction constants**, 8-19
 - coupler**
 - test port 1
 - See A33
 - test port 2
 - See A36
 - test port 3
 - See A34
 - test port 4
 - See A35
 - covers, analyzer**
 - illustrated, 6-97
 - part numbers, 6-96
 - removal and replacement
 - illustrated, 7-7
 - procedure, 7-6
 - removal warning, 1-4
 - CPU board**
 - See A21
 - cross-over cable, LAN**, 4-21
 - CSA mark**, 1-7
- ## D
- D receiver**
 - troubleshooting, 4-26
 - typical power output, 4-36
 - D trace**
 - troubleshooting, 4-26
 - dangerous voltage**, 1-4
 - data**
 - acquisition
 - operation, 5-28
 - subgroup, 5-26
 - option
 - recovering, 8-15
 - repairing, 8-15
 - storage
 - hard disk, 5-30
 - IDE, 5-30
 - DCOM**, 8-9
 - default, EE**
 - adjustment, 3-46
 - description**
 - functional
 - digital control group, 5-6
 - digital processing group, 5-6
 - power supply group, 5-6
 - receiver group, 5-6
 - signal separation group, 5-6
 - synthesized source group, 5-5
 - digital control group**
 - block diagram, 5-27
 - functional description of, 5-6
 - operation, 5-26
 - digital processing group**
 - block diagram, 5-27
 - functional description of, 5-6
 - operation, 5-26
 - directivity**
 - cause of failure, 8-11
 - definition of, 8-11
 - measurements affected by, 8-11
 - disabling**
 - options, 8-14
 - display**
 - assembly
 - operation, 5-28
 - parts list, 6-12
 - removal, 7-12, 7-13
 - troubleshooting, 4-12, 4-13
 - cable
 - removal, 7-12, 7-13
 - port, rear panel, 5-30
 - test
 - running, 4-15
 - documentation**
 - part numbers, 6-98
 - doubler boards**
 - See A7-A8 or A12-A13
 - dress panel**
 - lower front panel
 - illustrated, 6-11
 - part number, 6-10
 - dynamic range, high**
 - measurement configuration, 5-18
- ## E
- earth ground**, 1-3
 - EE default**
 - adjustment, 3-46
 - electrostatic discharge**
 - See ESD
 - enabling**
 - options, 8-14
 - entitlement certificate, option**, 8-13
 - environment, operating**
 - specifications, 3-4
 - verification, 3-4
 - equipment**
 - service test, required, 2-5
 - error terms**, 8-3
 - access to, 8-8
 - via COM/DCOM commands, 8-9
 - via front panel, 8-8
 - via SCPI commands (using GPIB), 8-9
 - cause of failure to, 8-3
 - descriptions, 8-10
 - directivity, 8-11

- flowgraph of one port, 8-4
- flowgraph of two port, 8-5, 8-6, 8-7
- identifying using flowgraphs, 8-4
- isolation, 8-12
- load match, 8-11
- magnitude
 - affected by, 8-3
 - monitoring over time, 8-3
 - shape affected by, 8-3
 - source match, 8-11
 - typical data, 8-10
 - using as diagnostic tool, 8-3
 - using to aid troubleshooting, 8-3
 - worse than typical values, 8-10
- ESD**
 - protection, 1-6, 3-4, 4-3, 7-3, 8-4
 - supplies
 - part numbers, 6-99
- exchange**
 - module
 - procedure, 6-5
 - rebuilt assemblies
 - program, 6-5
- EXT 10 MHz REF IN connector**
 - rear panel, 5-13
- EXT 10 MHz REF OUT connector**
 - rear panel, 5-13
- external**
 - analyzer
 - replaceable parts, 6-96, 6-97
 - monitor, 4-12
- F**
- failure**
 - broadband, 4-30
 - of connector repeatability check, 3-18
 - of insertion loss check, 3-14
 - of magnitude and phase stability check, 3-16
 - of operator's check, 3-11
 - of return loss check, 3-13
 - of system verification, 3-25
 - flowchart, 3-25
 - single vs. broadband, 4-30
- fan**
 - assemblies
 - replaceable parts, 6-88
 - removal and replacement
 - illustrated, 7-53
 - procedure, 7-52
 - troubleshooting, 4-11
- feet**
 - analyzer
 - illustrated, 6-97
 - part numbers, 6-96
- firmware**
 - checking current version, 8-17
 - upgrades, 8-17
- flowgraph**
 - of one port error terms, 8-4
 - of two port error terms, 8-5, 8-6, 8-7
 - using to identify error terms, 8-4
- frequency**
 - accuracy, test, 3-32
 - adjustment, at 10 MHz, 3-40
- frequency reference board**
 - See *A14*
- front frame**
 - illustrated, 6-11
 - part number, 6-10
- front panel**
 - assembly
 - replaceable parts, 6-10, 6-11, 6-12
 - assembly, removal and replacement
 - illustrated, 7-9
 - procedure, 7-8
 - display assembly
 - parts list, 6-12
 - display board
 - operation, 5-28
 - front frame
 - illustrated, 6-11
 - part number, 6-10
 - interconnects, 5-28
 - interface board
 - part number, 6-12
 - removal and replacement, 7-10, 7-11
 - troubleshooting, 4-12, 4-13
 - inverter board
 - part number, 6-12
 - keypad assembly
 - parts list, 6-12
 - removal and replacement, 7-11
 - troubleshooting, 4-13
 - knob
 - illustrated, 6-11
 - part number, 6-10
 - test, 4-15
 - troubleshooting, 4-13
 - LCD assembly
 - parts list, 6-12
 - LED board
 - illustrated, 6-23, 6-29, 6-35, 6-41, 6-47, 6-53, 6-59, 6-65, 6-71, 6-79
 - part number, 6-22, 6-28, 6-34, 6-46, 6-52, 6-58, 6-64, 6-70, 6-78
 - LED board, removal and replacement
 - illustrated, 7-51
 - procedure, 7-50
 - lower dress panel
 - illustrated, 6-11
 - part number, 6-10
 - lower overlay
 - illustrated, 6-11
 - part number, 6-10
 - nameplate
 - illustrated, 6-11
 - part number, 6-10
 - operation, 5-28
 - power switch board
 - parts list, 6-12
 - power switch overlay
 - illustrated, 6-11
 - part number, 6-10
 - subassemblies, removal and replacement
 - illustrated, 7-11
 - procedures, 7-10
 - subgroup, 5-26
 - touch screen
 - parts list, 6-12
 - trim strip, filler
 - illustrated, 6-11
 - part number, 6-10
 - troubleshooting, 4-13
 - USB board
 - part number, 6-12
 - USB controller board
 - part number, 6-12
- functional groups**, 5-4
- fuses**, 6-98
- G**
- gain, IF**
 - adjustment, 3-41
- general safety considerations**, 1-3
- GPIB**
 - board
 - See *A22*
 - cables
 - part numbers, 6-98
 - CONTROLLER
 - software, 4-17
 - systems check, 4-17
 - port
 - rear panel, 5-30
 - rear panel connector, 5-30
- ground, safety earth**, 1-3
- groups**
 - functional, 5-4
- H**
- handle**
 - damaged, 1-3
- HANDLER I/O**
 - connector
 - pin assignments, 5-15
 - rear panel, 5-13
- hard disk drive**
 - See *A55*

Hardware, 6-92

HDD

See A55

high dynamic range

measurement configuration, 5-18

HMA26.5

See A25

I

IDE

data storage, 5-30

IF gain

adjustment, 3-41

IF multiplexer board

See A24

insertion loss

check

failure of, 3-14

test port cables, 3-14

installing

a serial number, 8-16

instruction documentation symbol, 1-7

instrument

markings, 1-7

specifications, 3-6

interconnects

front panel, 5-28

HANDLER I/O

pin assignments, 5-15

PULSE I/O

pin assignments, 5-23

PWR I/O

pin assignments, 5-16

rear panel, 5-13, 5-22, 5-30

Display, 5-30

EXT 10 MHz REF IN, 5-13

EXT 10 MHz REF OUT, 5-13

GPIO, 5-30

HANDLER I/O, 5-13

LAN, 5-30

TEST SET I/O, 5-13

USB, 5-30

VGA, 5-30

TEST SET I/O

pin assignments, 5-14

internal analyzer

replaceable hardware

illustrated, 6-95

part numbers, 6-94

replaceable parts

illustrated, 6-95

part numbers, 6-94

internal performance test software, 3-28

inverter board

part number, 6-12

removal and replacement

illustrated, 7-11

procedure, 7-10

troubleshooting, 4-12

IP address, LAN, 4-19

ISM1-A mark, 1-7

isolation

cause of failure, 8-12

definition of, 8-12

measurements affected by, 8-12

K

keypad assembly

operation, 5-28

parts list, 6-12

removal and replacement

illustrated, 7-11

procedure, 7-10

test, 4-14

troubleshooting, 4-13

kits

calibration, 2-6, 3-6

rack mount

part numbers, 6-99

upgrade

order numbers, 6-99

verification, 2-6, 3-6

knob

front panel

illustrated, 6-11

part number, 6-10

test, 4-15

troubleshooting, 4-13

L

LAN

connector

rear panel, 5-30

cross-over cable, 4-21

IP address, 4-19

ping command, 4-19

ping to and from, 4-18

subnet mask, 4-19

testing between analyzers, 4-20

troubleshooting, 4-18

LCD assembly

parts list, 6-12

LED board

front panel

removal, 7-50

illustrated, 6-23, 6-29, 6-35, 6-41,

6-47, 6-53, 6-59, 6-65, 6-71, 6-79

part number, 6-22, 6-28, 6-34, 6-46,

6-52, 6-58, 6-64, 6-70, 6-78

linearity

source power

test, 3-31

test port output power

test, 3-31

lithium battery

disposal, 1-8

removal and replacement

illustrated, 7-55

procedure, 7-54

LO synthesizer board

See A15

load match

cause of failure, 8-11

definition of, 8-11

measurements affected by, 8-11

locating

replaceable part numbers

by reference designator, 6-6

M

machine screws

in external analyzer

illustrated, 6-97

part numbers, 6-96

in rear panel assembly

illustrated, 6-87

part numbers, 6-86

magnitude check

failure of, 3-16

test port cables, 3-15

maintenance

cleaning, 2-3

preventive

effect on error terms, 8-3

measurement

calibration, 8-3

configuration

high dynamic range, 5-18

normal, 5-17

system

troubleshooting, 4-23

traceability, 3-21

path, 3-21

uncertainty, 3-20

midplane board

illustrated, 6-18

part number, 6-16

removal and replacement

illustrated, 7-19

procedure, 7-18

miscellaneous replaceable parts

part numbers, 6-98

mixer brick

See A27 and A28

model numbers

upgrade kits, 6-99

module

exchange

procedure, 6-5

monitor, external, 4-12

motherboard, system

See A18

motherboard, test set

See A23

N

N1966A pulse I/O adapter, 2-4

nameplate

front panel

illustrated, 6-11

part number, 6-10

network analyzer

See analyzer

noise floor, test, 3-36

noise, trace noise test, 3-33

Non-ANSI/NCSL Z540-1-1994

verification, 3-9

O

OCXO (oven-controlled crystal oscillator)

frequency adjustment, 3-40

theory of operation, 5-12

operating

environment

specifications, 3-4

verification, 3-4

system

recovery, 8-18

operation

13.5 GHz synthesizer boards, 5-11

26.5 GHz source boards, 5-11

A7, A8, A12, and A13 doublers, 5-12

configurable test set, 5-17

CPU board, 5-29

data acquisition, 5-28

digital control, 5-26

digital processor, 5-26

display assembly, 5-28

frequency reference board, 5-12

front panel, 5-28

front panel display board, 5-28

hard disk drive, 5-30

HMA 26.5, 5-12

HMA26.5, 5-18

IF multiplexer board, 5-22

keypad assembly, 5-28

main RAM, 5-29

mixer brick, 5-21

power supply, 5-31

processing subgroup, 5-28

receiver group, 5-21

receiver step attenuators, 5-21

reference mixer switch, 5-21

signal separation group, 5-17

source group, 5-7

SPAM board—analog, 5-22

SPAM board—digital, 5-29

system

motherboard, 5-28

test port couplers, 5-18

test set motherboard, 5-13

operator's check, 3-10

accessories used in, 3-10

description of, 3-10

dialog box, 3-11

failure of, 3-11

performing, 3-10

option

data

recovering, 8-15

repairing, 8-15

enable utility, 8-13

accessing, 8-13

dialog box, 8-13

enabling and removing, 8-14

entitlement certificate, 8-13

hardware, 8-14

service and support, 2-8

software, 8-14

Option 200, bottom assembly

See bottom assembly, Option 200

Option 201, bottom assembly

See bottom assembly, Option 201

Option 210, bottom assembly

See bottom assembly, Option 210

Option 219, bottom assembly

See bottom assembly, Option 219

Option 400, bottom assembly

See bottom assembly, Option 400

Option 419, bottom assembly

See bottom assembly, Option 419

ordering information

options and upgrades, 2-4

replaceable parts, 6-4

output power

source

accuracy test, 3-29

linearity, 3-31

maximum test, 3-30

test port

accuracy test, 3-29

linearity, 3-31

maximum test, 3-30

overlay

lower front panel

illustrated, 6-11

part number, 6-10

power switch

part number, 6-10, 6-11

P

pads

required for servicing, 2-6

paint

touch-up

part numbers, 6-99

part numbers

See section in Chapter 6 titled

Replaceable Parts Listings

performance

tests, 3-28

calibration coefficients, 3-37

description of, 3-7

dynamic accuracy, 3-38

frequency accuracy, 3-32

noise floor, 3-36

receiver compression, 3-34

software, internal, 3-28

source maximum power output,
3-30

source power accuracy, 3-29

source power linearity, 3-31

test port output maximum power,
3-30

test port output power accuracy,
3-29

test port output power linearity, 3-31

trace noise, 3-33

verification

ANSI/NCSL Z540-1-1994, 3-8

non-ANSI/NCSL Z540-1-1994, 3-9

phase stability check

failure of, 3-16

test port cables, 3-15

pin assignments

connectors

HANDLER I/O, 5-15

PULSE I/O, 5-23

PWR I/O, 5-16

TEST SET I/O, 5-14

ping

command, LAN, 4-19

from network, 4-20

to analyzer, 4-19

pixel

damaged, 4-15

definition, 4-15

ports 1-4, typical power output, 4-36

post-repair procedures, 7-56

power button keypad

removal and replacement

illustrated, 7-11

procedure, 7-11

power supply

See A20

power switch

board

parts list, 6-12

removal, 7-11

overlay

part number, 6-10, 6-11

power up

troubleshooting, 4-6

power, test port output

accuracy test, 3-29

- linearity test, 3-31
 - maximum test, 3-30
 - pre-repair**
 - procedures
 - caution about, 7-3
 - warnings about, 7-3
 - preventive maintenance**
 - effect on error terms, 8-3
 - processing subgroup**
 - operation, 5-28
 - protection**
 - against ESD, 1-6, 3-4, 4-3, 7-3, 8-4
 - PULSE I/O**
 - adapter, N1966A, 2-4
 - connector
 - pin assignments, 5-23
 - PWR I/O**
 - connector
 - pin assignments, 5-16
 - R**
 - R receiver**
 - troubleshooting, 4-26
 - R trace**
 - troubleshooting, 4-26
 - rack mount kits**
 - part numbers, 6-99
 - RAM, main**
 - operation, 5-29
 - rear panel**
 - connectors
 - Display, 5-30
 - EXT 10 MHz REF IN, 5-13
 - GPIB, 5-30
 - HANDLER I/O, 5-13
 - LAN, 5-30
 - TEST SET I/O, 5-13
 - USB, 5-30
 - VGA, 5-30
 - interconnects, 5-13, 5-22, 5-30
 - removal and replacement
 - illustrated, 7-49
 - procedure, 7-48
 - replaceable parts
 - illustrated, 6-87
 - part numbers, 6-86
 - troubleshooting, 4-17
 - USB
 - troubleshooting, 4-17
 - rebuild-exchange assemblies**
 - program, 6-5
 - receiver**
 - A**
 - troubleshooting, 4-26, 4-35
 - typical power output, 4-36
 - accuracy
 - dynamic accuracy test, 3-38
 - adjustment, 3-43
 - B**
 - troubleshooting, 4-26, 4-35
 - typical power output, 4-36
 - C**
 - troubleshooting, 4-26, 4-35
 - typical power output, 4-36
 - calibration, 3-43
 - characterization
 - adjustment, 3-46
 - compression test, 3-34
 - D**
 - troubleshooting, 4-26, 4-35
 - typical power output, 4-36
 - display**
 - running the test, 4-26
 - dynamic accuracy test**, 3-38
 - functional description of**, 5-6
 - functional group**, 5-4
 - group**
 - block diagram, 5-24, 5-25
 - operation, 5-21
 - troubleshooting, 4-39
 - group, defined**, 4-28
 - linearity**
 - dynamic accuracy test, 3-38
 - outputs**
 - troubleshooting, 4-40
- R**
 - troubleshooting, 4-26
- step attenuator**
 - operation, 5-21
 - removal, 7-42, 7-43
 - troubleshooting, 4-41
- receiver coupler**
 - test port 1
 - See A29
 - test port 2
 - See A32
 - test port 3
 - See A30
 - test port 4
 - See A31
- recovery**
 - operating system, 8-18
 - option data, 8-15
- reference mixer switch**
 - See A37
- reference receiver**
 - See R receiver
- removing**
 - cover, warning, 1-4
 - options, 8-14
 - See section in Chapter 7 titled *Removal and Replacement Procedures*
- repair**
 - option data, 8-15
 - post-repair procedures, 7-56
 - procedures
 - caution about, 7-3
 - warnings about, 7-3
- replaceable cables**
 - flexible
 - See cables, flexible
 - RF
 - See cables, RF
 - ribbon
 - See cables, ribbon
 - wire harnesses
 - See cables, wire harnesses
- replaceable parts**
 - See section in Chapter 6 titled *Replaceable Parts Listings*
- replaceable RF cables**
 - See cables, RF
- replaceable ribbon cables**
 - See cables, ribbon
- replaceable wire harnesses**
 - See cables, wire harnesses
- replacement procedures**
 - See section in Chapter 7 titled *Removal and Replacement Procedures*
- return loss check**
 - failure of, 3-13
 - test port cables, 3-13
- RF cables**
 - See cables, RF
- ribbon cables**
 - See cables, ribbon
- rotary pulse generator (RPG)**
 - illustrated, 6-11
 - part number, 6-10
 - test, 4-15
 - troubleshooting, 4-13
- S**
- safety**
 - considerations, 1-3
 - earth ground, 1-3
 - symbols, 1-3
- SCPI**, 8-9
- screws**
 - in external analyzer
 - illustrated, 6-97
 - part numbers, 6-96
 - in rear panel assembly
 - illustrated, 6-87
 - part numbers, 6-86
- serial number**
 - changing, 8-16
 - installing, 8-16
- service**
 - battery
 - part numbers, 6-98
 - contacting Agilent, 2-8
 - options, 2-8
 - procedures

- caution about, 7-3
 - post-repair, 7-56
 - warnings about, 7-3
 - static safety parts
 - part numbers, 6-99
 - required, 2-7
 - test equipment
 - required, 2-5
 - tools
 - part numbers, 6-98
 - required, 2-7
 - warnings, 1-4
 - warranty
 - one-year return to Agilent, 2-8
 - standard, 2-8
 - shipment for service or repair, 2-9**
 - signal processing ADC module (SPAM) board**
 - illustrated, 6-18
 - part number, 6-16
 - signal separation group**
 - block diagram, 5-19, 5-20
 - defined, 4-28
 - functional description of, 5-6
 - functional group, 5-4
 - operation, 5-17
 - troubleshooting, 4-35, 4-36
 - single band failure, 4-30**
 - software**
 - options, 8-14
 - solid state drive**
 - See A55
 - source**
 - adjustment, 3-42
 - calibration, 3-42
 - functional group, 5-4
 - group
 - defined, 4-28
 - operation, 5-7
 - troubleshooting, 4-30
 - match
 - cause of failure, 8-11
 - definition of, 8-11
 - measurements affected by, 8-11
 - maximum output power test, 3-30
 - power accuracy test, 3-29
 - power linearity test, 3-31
 - source 1 board**
 - See A4
 - source 2 board**
 - See A17
 - source step attenuator**
 - removal and replacement
 - illustrated, 7-43
 - procedure, 7-42
 - troubleshooting, 4-37
 - SPAM board**
 - See A16
 - speaker**
 - troubleshooting, 4-13
 - specifications**
 - instrument, 3-6
 - stabilization, warm up time, 3-4
 - system, 3-6
 - splitter**
 - See A26
 - SSD**
 - See A55
 - stabilization**
 - warm up time, 3-4
 - static safety parts**
 - required for servicing, 2-7
 - step attenuator, receiver**
 - See A46 - A49
 - step attenuator, source**
 - See A38 - A41
 - storage data**
 - IDE, 5-30
 - strap handle**
 - analyzer
 - illustrated, 6-97
 - part number, 6-96
 - subgroup**
 - data acquisition and processing, 5-26
 - front panel, 5-26
 - subnet mask, LAN, 4-19**
 - substitution**
 - cable, 3-23
 - calibration kits, 3-23
 - verification kits, 3-23
 - supplies**
 - battery
 - part number, 6-98
 - ESD
 - part numbers, 6-99
 - support**
 - contacting Agilent, 2-8
 - options, 2-8
 - organization, 2-8
 - switch, reference mixer**
 - See A37
 - synthesized source**
 - See A4 and A17
 - synthesizer bandwidth**
 - adjustment, 3-41
 - system**
 - adjustments, 3-1, 3-39
 - EE default, 3-46
 - frequency at 10 MHz, 3-40
 - getting ready, 3-4
 - IF gain, 3-41
 - receiver calibration, 3-43
 - receiver characterization, 3-46
 - source calibration, 3-42
 - synthesizer bandwidth, 3-41
 - checks, 3-1
 - getting ready, 3-4
 - operating, recovery, 8-18
 - specifications, 3-6
 - verification, 3-1, 3-6, 3-19
 - dialog box, 3-23
 - example of results, 3-26, 3-27
 - failure flowchart, 3-25
 - failure of, 3-25
 - getting ready, 3-4
 - interpreting results, 3-26
 - performing, 3-22
 - procedure, 3-23
 - what it verifies, 3-19
- system, motherboard**
 - See A18
- ## T
- test**
 - adjustments, 3-39
 - calibration coefficients, 3-37
 - dynamic accuracy, 3-38
 - frequency accuracy, 3-32
 - noise floor, 3-36
 - performance, 3-7, 3-28
 - frequency accuracy, 3-32
 - source maximum power output, 3-30
 - source power accuracy, 3-29
 - test port maximum power output, 3-30
 - test port power accuracy, 3-29
 - receiver compression, 3-34
 - source group, 4-30
 - source power linearity, 3-31
 - test port output power linearity, 3-31
 - trace noise, 3-33
 - test equipment**
 - required for service, 2-5
 - required for servicing, 2-5
 - test port**
 - cable checks, 3-10
 - accessories used in, 3-12
 - connector repeatability, 3-17
 - connector repeatability failure, 3-18
 - insertion loss, 3-14
 - insertion loss failure, 3-14
 - magnitude and phase stability, 3-15
 - magnitude and phase stability failure, 3-16
 - performing, 3-12
 - return loss, 3-13
 - return loss failure, 3-13
 - coupler
 - troubleshooting, 4-37
 - dynamic accuracy test, 3-38
 - maximum output power test, 3-30
 - noise floor test, 3-36
 - output power accuracy test, 3-29
 - output power linearity test, 3-31

- test port 1**
 - bias tee
 - See A42
 - receiver coupler
 - See A29
 - receiver step attenuator
 - See A46
 - source step attenuator
 - See A38
- test port 2**
 - bias tee
 - See A45
 - receiver coupler
 - See A32
 - receiver step attenuator
 - See A49
 - source step attenuator
 - See A41
- test port 3**
 - bias tee
 - See A43
 - receiver coupler
 - See A30
 - receiver step attenuator
 - See A47
 - source step attenuator
 - See A39
- test port 4**
 - bias tee
 - See A44
 - receiver coupler
 - See A31
 - receiver step attenuator
 - See A48
 - source step attenuator
 - See A40
- TEST SET I/O**
 - connector
 - pin assignments, 5-14
 - rear panel, 5-13
- test set motherboard**
 - See A23
- tools**
 - required for servicing, 2-7
 - service, part numbers, 6-98
- top assembly**
 - replaceable cables, all
 - illustrated, 6-21
 - part numbers, 6-20
 - replaceable parts
 - illustrated, 6-18, 6-89, 6-91
 - part numbers, 6-16, 6-90
- touch screen**
 - parts list, 6-12
 - removal and replacement
 - illustrated, 7-12, 7-13
 - procedure, 7-12
- touch-up**
- paint
 - part numbers, 6-99
- trace**
 - noise, test, 3-33
 - troubleshooting
 - all traces, 4-29
- traceability**
 - measurement, 3-21
 - path, 3-21
- trim strip, filler**
 - front panel
 - illustrated, 6-11
 - part number, 6-10
- troubleshooting**
 - A1 front panel interface board, 4-12, 4-13
 - A10 26.5 GHz source 2 board, 4-33
 - A14 frequency reference board, 4-31
 - A15 13.5 GHz LO synthesizer board, 4-31
 - A16 SPAM board, 4-41
 - A17 13.5 GHz source 2 synthesizer board, 4-33
 - A20 power supply assembly, 4-7
 - A21 CPU board, 4-17
 - A24 IF multiplexer board, 4-41
 - A25 HMA26.5, 4-32
 - A26 splitter, 4-32
 - A27 mixer brick, 4-40
 - A28 mixer brick, 4-40
 - A29 test port 1 receiver coupler, 4-37
 - A3 display assembly, 4-12, 4-13
 - A30 test port 3 receiver coupler, 4-37
 - A31 test port 4 receiver coupler, 4-37
 - A32 test port 2 receiver coupler, 4-37
 - A33 test port 1 coupler, 4-37
 - A34 test port 3 coupler, 4-37
 - A35 test port 4 coupler, 4-37
 - A36 test port 2 coupler, 4-37
 - A37 reference mixer switch, 4-40
 - A38 test port 1 source step attenuator, 4-37
 - A39 test port 3 source step attenuator, 4-37
 - A4 13.5 GHz source 1 synthesizer board, 4-33
 - A40 test port 4 source step attenuator, 4-37
 - A41 test port 2 source step attenuator, 4-37
 - A42 test port 1 bias tee, 4-37
 - A43 test port 3 bias tee, 4-37
 - A44 test port 4 bias tee, 4-37
 - A45 test port 2 bias tee, 4-37
 - A46 test port 1 receiver step attenuator, 4-41
 - A47 test port 3 receiver step attenuator, 4-41
 - A48 test port 4 receiver step attenuator, 4-41
 - A49 test port 2 receiver step attenuator, 4-41
 - A5 26.5 GHz source 1 board, 4-33
 - A7, A8, A12, and A13 50 GHz doubler boards, 4-34
 - all traces, 4-29
 - check the basics, 4-4
 - error term failure
 - suspect devices, 8-3
 - fans, 4-11
 - front panel, 4-13
 - front panel keypad, 4-13
 - front panel knob, 4-13
 - front-panel USB, 4-13
 - GPIB CONTROLLER port, 4-17
 - inverter board, 4-12
 - LAN, 4-18
 - measurement system, 4-23
 - receiver group, 4-39
 - running the receiver display, 4-26
 - signal separation group, 4-35
 - source group, 4-30
 - traces A, B, C, D, R, 4-26
 - where to begin, 4-28
 - ping command, 4-19
 - power output of receiver A, 4-35
 - power output of receiver B, 4-35
 - power output of receiver C, 4-35
 - power output of receiver D, 4-35
 - power up, 4-6
 - power supply check, 4-7
 - rear panel, 4-17
 - rear-panel USB, 4-17
 - receiver A, 4-26, 4-35
 - receiver B, 4-26, 4-35
 - receiver C, 4-26, 4-35
 - receiver D, 4-26, 4-35
 - receiver outputs, 4-40
 - receiver R, 4-26
 - RPG, 4-13
 - signal separation group, 4-36
 - source group
 - single vs. broadband, 4-30
 - speaker, 4-13
 - trace A, 4-26
 - trace B, 4-26
 - trace C, 4-26
 - trace D, 4-26
 - trace R, 4-26
 - typical power output
 - Port 1, 4-36
 - Port 2, 4-36
 - Port 3, 4-36
 - Port 4, 4-36

using controllers to system
troubleshoot, 4-18
using error terms, 8-3
where to begin, 4-4

U

uncertainty
measurement, 3-20
upgrade
analyzer, 2-4
firmware, 8-17
downloading from the internet, 8-17
how to order, 2-4
kits, order numbers, 6-99

USB

accessories
part numbers, 6-99
board
part number, 6-12
removal, 7-11
removal procedure, 7-10
troubleshooting, 4-13
port
rear panel connector, 5-30
rear panel
troubleshooting, 4-17

utility

option enable, 8-13
accessing, 8-13
dialog box, 8-13

V

VCO (voltage-controlled oscillator)
defined, 5-7

ventilation requirements, 1-3

verification

ANSI/NCSL Z540-1-1994, 3-8
kits, 2-6, 3-6
substitution, 3-23
non-ANSI/NCSL Z540-1-1994, 3-9
of operating environment, 3-4
of operating specifications, 3-4
system, 3-1, 3-6, 3-19
dialog box, 3-23
example of results, 3-26, 3-27
failure flowchart, 3-25
failure of, 3-25
getting ready, 3-4
interpreting results, 3-26
performing, 3-22
procedure, 3-23
what it verifies, 3-19

VGA

monitor, 4-12
port
rear panel connector, 5-30

W

warm up

analyzer, 3-4

warning

for servicing, 1-4
various, 1-3

warranty

service
one-year return to Agilent, 2-8
standard, 2-8

Windows

, 2-5

wire harnesses

See cables, wire harnesses

This page has been intentionally left blank.

This information is subject to change without notice.

© Keysight Technologies 2011 - 2014

December 1, 2014



N5225-90001
www.keysight.com