

Keysight Add Source and Receiver Attenuators Upgrade Kit

To Upgrade PNA N5224A or N5225A Option 401 to Option 417

Upgrade Kit Order Numbers: N5224AU-417 or N5225AU-417

Keysight Kit Number: N5225-60107

NOTICE: This document contains references to Agilent Technologies. Agilent's former Test and Measurement business has become Keysight Technologies. For more information, go to www.keysight.com.



WARRANTY STATEMENT

THE MATERIAL CONTAINED IN THIS DOCUMENT IS PROVIDED "AS IS," AND IS SUBJECT TO BEING CHANGED, WITHOUT NOTICE, IN FUTURE EDITIONS. FURTHER, TO THE MAXIMUM EXTENT PERMITTED BY APPLICABLE LAW, KEYSIGHT DISCLAIMS ALL WARRANTIES, EITHER EXPRESS OR IMPLIED WITH REGARD TO THIS MANUAL AND ANY INFORMATION CONTAINED HEREIN, INCLUDING BUT NOT LIMITED TO THE IMPLIED WARRANTIES OF MERCHANTABILITY AND FITNESS FOR A PARTICULAR PURPOSE. KEYSIGHT SHALL NOT BE LIABLE FOR ERRORS OR FOR INCIDENTAL OR CONSEQUENTIAL DAMAGES IN CONNECTION WITH THE FURNISHING, USE, OR PERFORMANCE OF THIS DOCUMENT OR ANY INFORMATION CONTAINED HEREIN. SHOULD KEYSIGHT AND THE USER HAVE A SEPARATE WRITTEN AGREEMENT WITH WARRANTY TERMS COVERING THE MATERIAL IN THIS DOCUMENT THAT CONFLICT WITH THESE TERMS, THE WARRANTY TERMS IN THE SEPARATE AGREEMENT WILL CONTROL.

DFARS/Restricted Rights Notice

If software is for use in the performance of a U.S. Government prime contract or subcontract, Software is delivered and licensed as "Commercial computer software" as defined in DFAR 252.227-7014 (June 1995), or as a "commercial item" as defined in FAR 2.101(a) or as "Restricted computer software" as defined in FAR 52.227-19 (June 1987) or any equivalent agency regulation or contract clause. Use, duplication or disclosure of Software is subject to Keysight Technologies' standard commercial license terms, and non-DOD Departments and Agencies of the U.S. Government will receive no greater than Restricted Rights as defined in FAR 52.227-19(c)(1-2) (June 1987). U.S. Government users will receive no greater than Limited Rights as defined in FAR 52.227-14 (June 1987) or DFAR 252.227-7015 (b)(2) (November 1995), as applicable in any technical data.

Safety Notes

The following safety notes are used throughout this document. Familiarize yourself with each of these notes and its meaning before performing any of the procedures in this document.

WARNING **Warning denotes a hazard. It calls attention to a procedure which, if not correctly performed or adhered to, could result in injury or loss of life. Do not proceed beyond a warning note until the indicated conditions are fully understood and met.**

CAUTION Caution denotes a hazard. It calls attention to a procedure that, if not correctly performed or adhered to, could result in damage to or destruction of the instrument. Do not proceed beyond a caution note until the indicated conditions are fully understood and met.

Description of the Upgrade

This upgrade adds the following items to your N5224A Option 401 or N5225A Option 401 network analyzer:

- a 60-dB source attenuator in each source port channel
- a 35-dB receiver attenuator in each receiver channel
- front panel overlay replacement
- new cables

After installation of this upgrade, your analyzer will be an N5224A Option 417 or N5225A Option 417.

Getting Assistance from Keysight

By internet, phone, or fax, get assistance with all your test and measurement needs.

Contacting Keysight

Assistance with test and measurements needs and information on finding a local Keysight office are available on the Web at:

<http://www.keysight.com/find/assist>

If you do not have access to the Internet, please contact your Keysight field engineer.

NOTE In any correspondence or telephone conversation, refer to the Keysight product by its model number and full serial number. With this information, the Keysight representative can determine whether your product is still within its warranty period.

Getting Prepared

CAUTION The PNA contains extremely sensitive components that can be ruined if mishandled. Follow instructions carefully when making cable connections, especially wire harness connections.

The person performing the work accepts responsibility for the full cost of the repair or replacement of damaged components.

To successfully install this upgrade kit, you will need the following:

- A license key - refer to “[License Key Redemption](#)” below.
- A PDF copy or a paper copy of the PNA Service Guide - refer to “[Downloading the Online PNA Service Guide](#)” below.
- An ESD-safe work area - refer to “[Protecting Your Workspace from Electrostatic Discharge](#)” below.
- Correct tools - refer to “[Tools Required for the Installation](#)” on page 6.
- Enough time - refer to “[About Installing the Upgrade](#)” on page 6.
- Test equipment for the post-upgrade adjustments and full instrument calibration. To view the equipment list, click the Chapter 3 bookmark “[Tests and Adjustments](#)” in the PDF Service Guide¹.

License Key Redemption

NOTE The enclosed Option Entitlement Certificate is a receipt, verifying that you have purchased a licensed option for the PNA of your choice. You must now use a Keysight Web page to request a license key for the instrument that will receive the option.

To enable the option product, you must request a license key from: <http://www.keysight.com/find/softwarelicense>. To complete the request, you will need to gather the following information:

- From the certificate
 - o Order number
 - o Certificate number
- From your instrument
 - o Model number
 - o Serial number
 - o Host ID

The instrument information is available on the network analyzer – on the analyzer’s **Help** menu, click **About Network Analyzer**.

If you provide an email address, Keysight will promptly email your license key. Otherwise, you will receive your license key via postal mail.

1. See “[Downloading the Online PNA Service Guide](#)” on page 5.

Downloading the Online PNA Service Guide

To view the online Service Guide for your PNA model number, use the following steps:

1. Go to www.keysight.com.
2. In the Search box, enter the model number of the analyzer (Ex: N5242A) and click **Search**.
3. Click **Technical Support > Manuals**.
4. Click **Service Manual**.
5. Click the service guide title to download the PDF file.
6. When the PDF of the Service Guide is displayed, scroll through the Contents section bookmarks to locate the information needed.

Protecting Your Workspace from Electrostatic Discharge

For information, click on the Chapter 1 bookmark, “Electrostatic Discharge Protection” in the PDF Service Guide¹.

ESD Equipment Required for the Installation

| Description | Keysight Part Number |
|--|----------------------|
| ESD grounding wrist strap | 9300-1367 |
| 5-ft grounding cord for wrist strap | 9300-0980 |
| 2 x 4 ft conductive table mat and 15-ft grounding wire | 9300-0797 |
| ESD heel strap (for use with conductive floors) | 9300-1308 |

1. See “[Downloading the Online PNA Service Guide](#)” on page 5.

Tools Required for the Installation

| Description | Qty | Part Number |
|--|-----|-------------|
| T-10 TORX driver - set to 9 in-lbs (1.02 N.m) | 1 | N/A |
| T-20 TORX driver - set to 21 in-lbs (2.38 N.m) | 1 | N/A |
| 5/16-in (8 mm) nutsetter or open end torque wrench - set to 10 in-lbs (1.13 N.m) | 1 | N/A |

CAUTION Use a 5/16-in torque wrench set to 10 in-lbs on all cable connections.

About Installing the Upgrade

| | |
|--|--|
| Products affected | N5224A and N5225A Option 401 |
| Installation to be performed by | Keysight service center or personnel qualified by Keysight |
| Estimated installation time | 2 hours |
| Estimated adjustment time | 0.5 hour |
| Estimated full instrument calibration time | 4.5 hours |

Items Included in the Upgrade Kit¹

Check the contents of your kit against the following list. If any part is missing or damaged, contact Keysight Technologies. Refer to [“Getting Assistance from Keysight” on page 3](#).

Table 1 Contents of Upgrade Kit N5225-60107

| Ref Desig. | Description | Qty | Part Number |
|-------------|---|-----|-------------|
| -- | Installation note (this document) | 1 | N5225-90107 |
| A38– A41 | 0–60 dB source step attenuator | 4 | 33325-60016 |
| A46– A49 | 0-35 dB receiver step attenuator | 4 | 33325-60017 |
| -- | Attenuator bracket (For A47 port 3 & A48 port 4 rcvr attenuators & all src attenuators.) | 6 | N5245-00015 |
| -- | Attenuator bracket (For A46 port 1 and A49 port 2 receiver attenuators.) | 2 | N5225-00001 |
| -- | Front panel overlay | 1 | N5225-80003 |
| -- | Machine screw, M3 x 8, pan head (to attach brackets to attenuators; to attach port 1 and port 2 receiver attenuators to deck) | 27 | 0515-0372 |
| -- | Machine screw, M3 x 6, pan head (to attach source attenuators and port 3 and port 4 receiver attenuators to deck) | 15 | 0515-0430 |
| - | Cable tie wrap | 6 | 1400-0249 |
| - | Cable clamp | 11 | 1400-1334 |
| W12 | A29 port 1 receiver coupler to W11 | 1 | N5245-20050 |
| W18 | A32 port 2 receiver coupler to W17 | 1 | N5245-20049 |
| W21 | A29 port 1 receiver coupler to A37 reference mixer switch | 1 | N5245-20008 |
| W25 | A30 port 3 receiver coupler to front-panel REF 3 SOURCE OUT | 1 | N5245-20116 |
| W29 | A31 port 4 receiver coupler to front-panel REF 4 SOURCE OUT | 1 | N5245-20117 |
| W33 | RF cable, A32 port 2 receiver coupler to front-panel REF 2 SOURCE OUT | 1 | N5245-20010 |
| W47 | REF 2 RCVR R2 IN to A27 mixer brick (R2) | 1 | N5245-20115 |
| W81 | RF cable, A29 test port 1 receiver coupler to A38 test port 1 source attenuator | 1 | N5245-20029 |
| W82 | RF cable, A38 test port 1 source attenuator to front-panel Port 1 SOURCE OUT | 1 | N5245-20077 |
| W85 | RF cable, A30 test port 3 receiver coupler to A39 test port 3 source attenuator | 1 | N5245-20026 |
| W86 | RF cable, A39 test port 3 source attenuator to front-panel Port 3 SOURCE OUT | 1 | N5245-20027 |
| W89 | RF cable, A31 test port 4 receiver coupler to A40 test port 4 source attenuator | 1 | N5245-20026 |
| W90 | RF cable, A40 test port 4 source attenuator to front-panel Port 4 SOURCE OUT | 1 | N5245-20028 |
| W93 | RF cable, A32 test port 2 receiver coupler to A41 test port 2 source attenuator | 1 | N5245-20029 |

1. In addition to the upgrade kit, the shipment includes an Option Entitlement Certificate. Refer to [“License Key Redemption” on page 4](#) for important information about this certificate.

Table 1 Contents of Upgrade Kit N5225-60107

| Ref Desig. | Description | Qty | Part Number |
|------------|--|-----|------------------------------|
| W94 | RF cable, A41 test port 2 source attenuator to front-panel Port 2 SOURCE OUT | 1 | N5245-20031 |
| W97 | RF cable, front-panel Port 1 RCVR A IN to A46 port 1 receiver attenuator | 1 | N5245-20054 |
| W98 | RF cable, A46 port 1 receiver attenuator to A27 mixer brick (A) | 1 | N5245-20056 |
| W99 | RF cable, front-panel Port 3 RCVR C IN to A47 port 3 receiver attenuator | 1 | N5245-20073 |
| W100 | RF cable, A47 port 3 receiver attenuator to A28 mixer brick (C) | 1 | N5245-20066 |
| W101 | RF cable, front-panel Port 4 RCVR D IN to A48 port 4 receiver attenuator | 1 | N5245-20074 |
| W102 | RF cable, A48 port 4 receiver attenuator to A28 mixer brick (D) | 1 | N5245-20075 |
| W103 | RF cable, Port 2 RCVR B IN to A49 port 2 receiver attenuator | 1 | N5245-20055 |
| W104 | RF cable, A49 port 2 receiver attenuator to A27 mixer brick (B) | 1 | N5245-20057 |
| -- | Ribbon cable, A23 test set motherboard J205 to A46 port 1 receiver attenuator | 4 | N5245-60026 Was 8121-0982 |
| -- | Ribbon cable, A23 test set motherboard J206 to A47 port 3 receiver attenuator | | |
| -- | Ribbon cable, A23 test set motherboard J207 to A48 port 4 receiver attenuator | | |
| -- | Ribbon cable, A23 test set motherboard J208 to A49 port 2 receiver attenuator | | |
| -- | Ribbon cable, A23 test set motherboard J549 to A38 test port 1 source attenuator | 4 | N5245-60006 |
| -- | Ribbon cable, A23 test set motherboard J547 to A39 test port 3 source attenuator | | |
| -- | Ribbon cable, A23 test set motherboard J548 to A40 test port 4 source attenuator | | |
| -- | Ribbon cable, A23 test set motherboard J546 to A41 test port 2 source attenuator | | |

NOTE Extra quantities of items such as protective plastic caps, screws, cable ties, and cable clamps may be included in this upgrade kit. It is normal for some of these items to remain unused after the upgrade is completed.

Installation Procedure for the Upgrade

The network analyzer must be in proper working condition prior to installing this option. Any necessary repairs must be made before proceeding with this installation.

WARNING **This installation requires the removal of the analyzer's protective outer covers. The analyzer must be powered down and disconnected from the mains supply before performing this procedure.**

Overview of the Installation Procedure

- Step 1. Obtain a Keyword and Verify the Information.
- Step 2. Remove the Outer Cover.
- Step 3. Remove Some Bottom-Side (Test Set) Cables.
- Step 4. Assemble the Port 1 and Port 2 Receiver Attenuator Assemblies.
- Step 5. Install the Port 1 and Port 2 Receiver Attenuator Assemblies.
- Step 6. Assemble the Port 3 and Port 4 Receiver Attenuator Assemblies.
- Step 7. Install the Port 3 and Port 4 Receiver Attenuator Assemblies.
- Step 8. Assemble the Source Attenuator Assemblies.
- Step 9. Install the Source Attenuator Assemblies.
- Step 10. Install Some Bottom-Side (Test Set) Cables.
- Step 11. Remove the Old Lower Front Panel Overlay.
- Step 12. Reinstall Front Panel Assembly.
- Step 13. Install the New Lower Front Panel Overlay.
- Step 14. Reinstall Front Panel Jumpers.
- Step 15. Position the Cables and Wires to Prevent Pinching.
- Step 16. Reinstall the Outer Cover.
- Step 17. Enable Option 417.
- Step 18. Perform Post-Upgrade Adjustments and Calibration.
- Step 19. Prepare the PNA for the User.

Step 1. Obtain a Keyword and Verify the Information

Follow the instructions on the Option Entitlement Certificate supplied to obtain a license key for installation of this upgrade. Refer to [“License Key Redemption” on page 4](#).

Verify that the model number, serial number, and option number information on the license key match those of the instrument on which this upgrade will be installed.

If the model number, serial number, or option number do not match those on your license key, you will not be able to install the option. If this is the case, contact Keysight for assistance before beginning the installation of this upgrade. Refer to [“Contacting Keysight” on page 3](#).

Once the license key has been received and the information verified, you can proceed with the installation at step 2.

Step 2. Remove the Outer Cover

For instructions, click the Chapter 7 bookmark “Removing the Covers” in the PDF Service Guide¹.

1. See [“Downloading the Online PNA Service Guide” on page 5](#).

Step 3. Remove Some Bottom-Side (Test Set) Cables

NOTE Leave the gray flexible cables, the wire harnesses, and the ribbon cables connected where possible. **Any that are removed should be labeled for reconnection later.**

CAUTION Be careful not to damage the center pins of the semirigid cables. Some flexing of the cables may be necessary but do not over-bend them.

1. Place the analyzer bottom-side up on a flat surface.
2. Remove the following cables. To see an image showing the location of these cables, click the Chapter 6 bookmark “Bottom RF Cables, Standard 4-Port Configuration, Option 401” in the PDF Service Guide¹.

These cables may be discarded - they will not be reinstalled.

- W12 (N5245-20109) A29 port 1 receiver coupler to W11
- W18 (N5245-20111) A32 port 2 receiver coupler to W17
- W19 (N5245-20039) A29 test port 1 receiver coupler to front-panel Port 1 SOURCE OUT
- W21 (N5245-20110) A29 port 1 receiver coupler to A37 reference mixer switch
- W23 (N5245-20051) A30 test port 3 receiver coupler to front-panel Port 3 SOURCE OUT
- W25 (N5245-20016) A30 port 3 receiver coupler to front-panel REF 3 SOURCE OUT
- W27 (N5245-20052) A31 test port 4 receiver coupler to front-panel Port 4 SOURCE OUT
- W29 (N5245-20017) A31 port 4 receiver coupler to front-panel REF 4 SOURCE OUT
- W31 (N5245-20040) A32 test port 2 receiver coupler to front-panel Port 2 SOURCE OUT
- W33 (N5245-20108) A32 port 2 receiver coupler to front-panel REF 2 SOURCE OUT
- W37 (N5245-20041) Front-panel Port 1 RCVR A IN to A27 mixer brick (A)
- W38 (N5245-20037) Front-panel Port 3 RCVR C IN to A28 mixer brick (C)
- W39 (N5245-20038) Front-panel Port 4 RCVR D IN to A28 mixer brick (D)
- W40 (N5245-20042) Port 2 RCVR B IN to A27 mixer brick (B)
- W46 (N5245-20011) Front-panel REF 2 RCVR R2 IN to A27 mixer brick (R2)

These cables must be saved - they will be reinstalled.

- W14 (N5245-20043) A30 port 3 receiver coupler to W13
- W16 (N5245-20044) A31 port 4 receiver coupler to W15
- W44 (N5245-20020) REF 3 RCVR R3 IN to A28 mixer brick (R3)
- W45 (N5245-20021) REF 4 RCVR R4 IN to 3 dB pad on A28 mixer brick (R4)
- W36 (N5245-20155) Front panel jumpers (quantity = 12)

NOTE: Remove and save the cable guards for the front panel jumpers.

1. See “[Downloading the Online PNA Service Guide](#)” on page 5.

Step 4. Assemble the Port 1 and Port 2 Receiver Attenuator Assemblies

Refer to [Figure 1](#) for this step of the procedure. New parts are listed in [Table 1 on page 7](#). Use a T-10 TORX driver to tighten all screws.

Figure 1 Port 1 and Port 2 Receiver Attenuator and Bracket Assembly

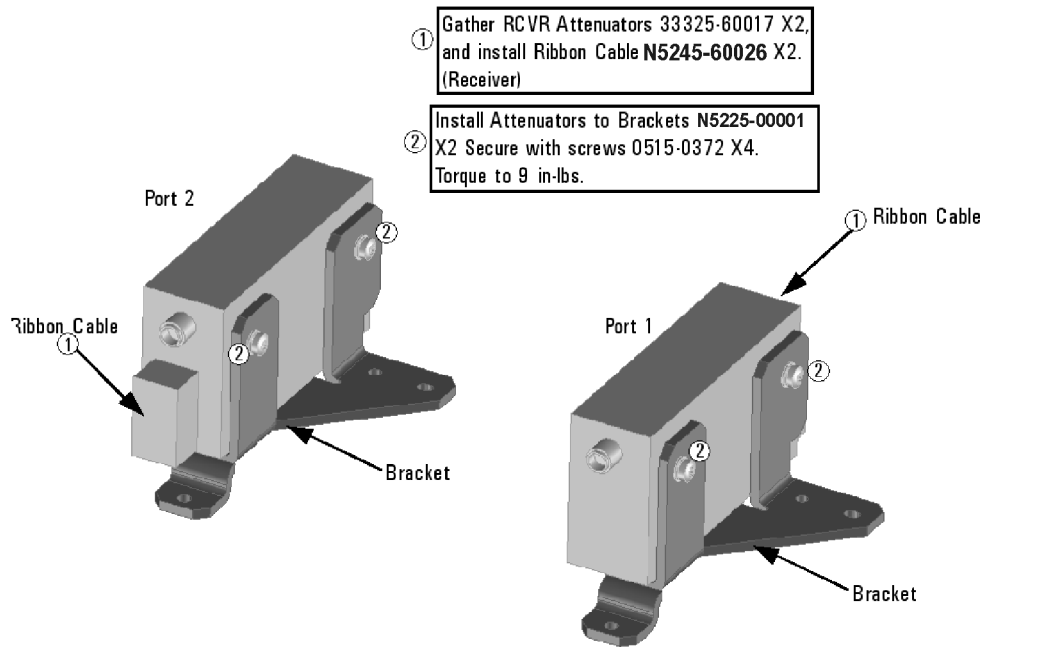

N5225_107_01

Step 5. Install the Port 1 and Port 2 Receiver Attenuator Assemblies

Refer to [Figure 2](#) for this step of the procedure. New parts are listed in [Table 1 on page 7](#). Use a T-10 TORX driver to tighten all screws.

Figure 2 Port 1 and Port 2 Receiver Attenuator Assemblies Installation

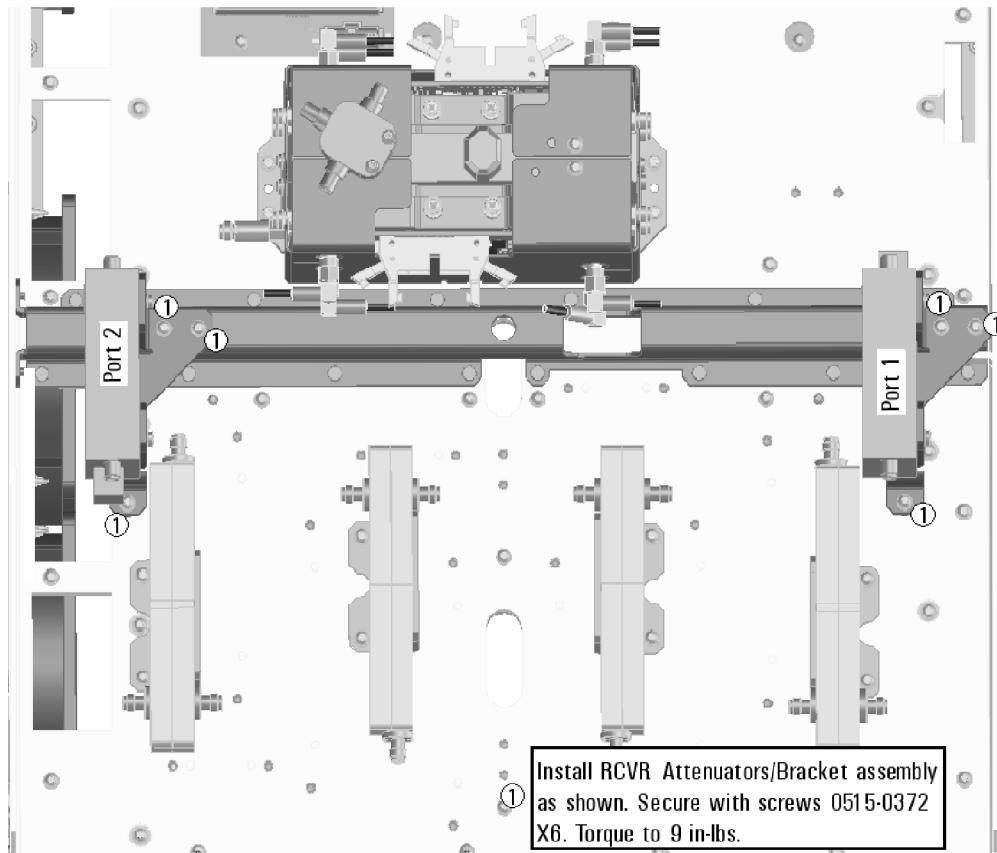

N5225_107_02

Step 6. Assemble the Port 3 and Port 4 Receiver Attenuator Assemblies

Refer to [Figure 3](#) for this step of the procedure. New parts are listed in [Table 1](#) on [page 7](#). Use a T-10 TORX driver to tighten all screws.

Figure 3 Port 3 and Port 4 Receiver Attenuator and Bracket Assembly

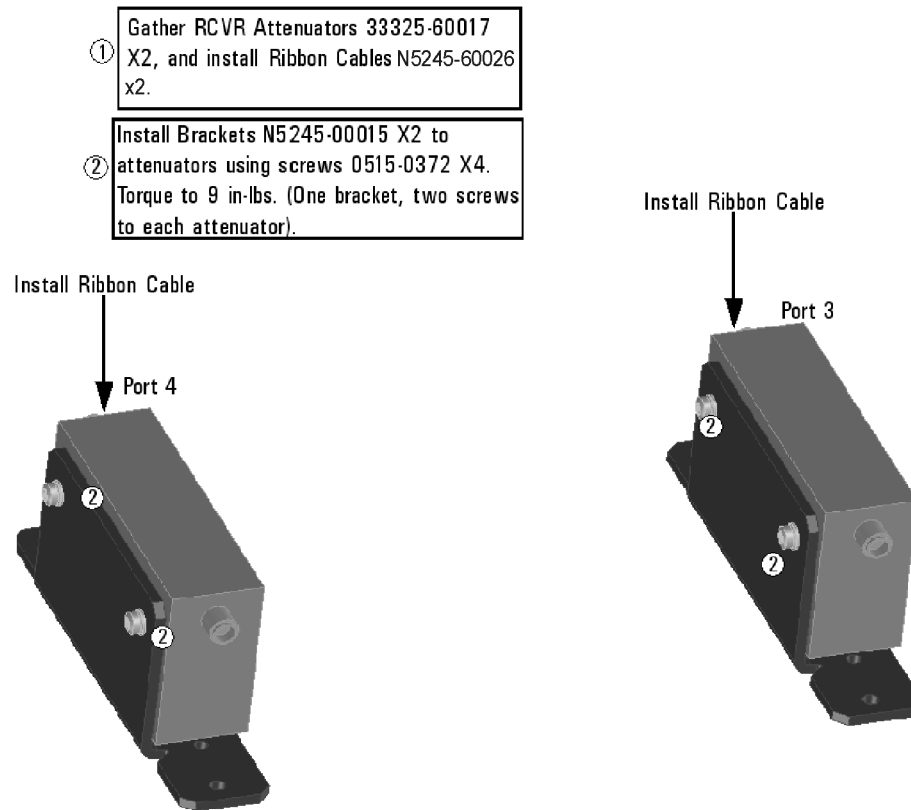

N5225_107_03

Step 7. Install the Port 3 and Port 4 Receiver Attenuator Assemblies

Refer to [Figure 4](#) for this step of the procedure. New parts are listed in [Table 1 on page 7](#). Use a T-10 TORX driver to tighten all screws.

Figure 4 Port 3 and Port 4 Receiver Attenuator Assemblies Installation

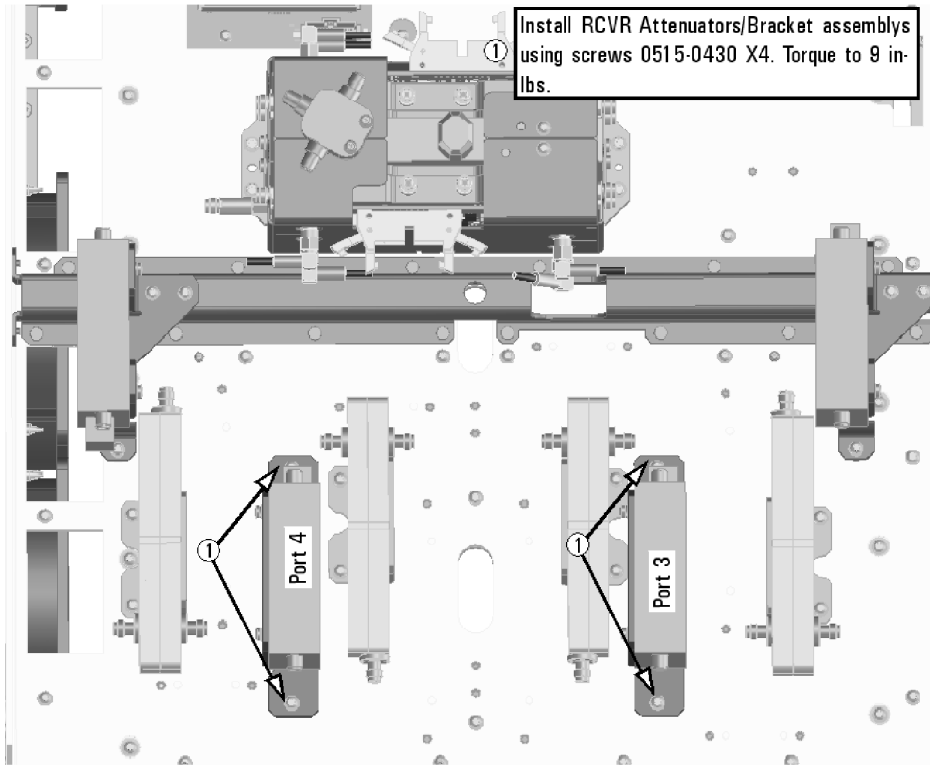

N5225_107_04

Step 8. Assemble the Source Attenuator Assemblies

Refer to [Figure 5](#) for this step of the procedure. New parts are listed in [Table 1](#) on [page 7](#). Use a T-10 TORX driver to tighten all screws.

Figure 5 Source Attenuator and Brackets Assembly

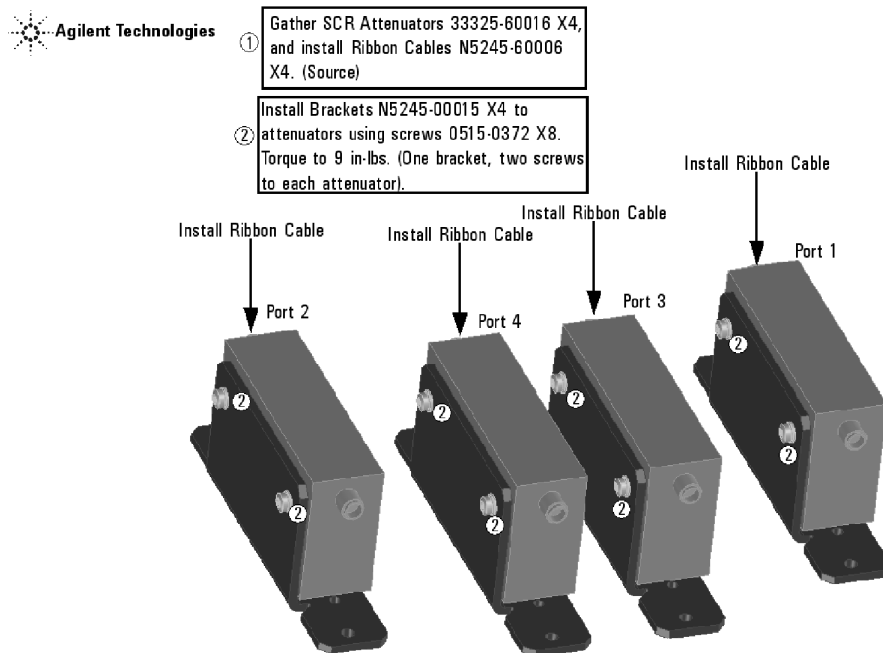

N5225_107_05

Step 9. Install the Source Attenuator Assemblies

Refer to [Figure 6](#) for this step of the procedure. New parts are listed in [Table 1](#) on [page 7](#). Use a T-10 TORX driver to tighten all screws.

Figure 6 Source Attenuator Assemblies Installation

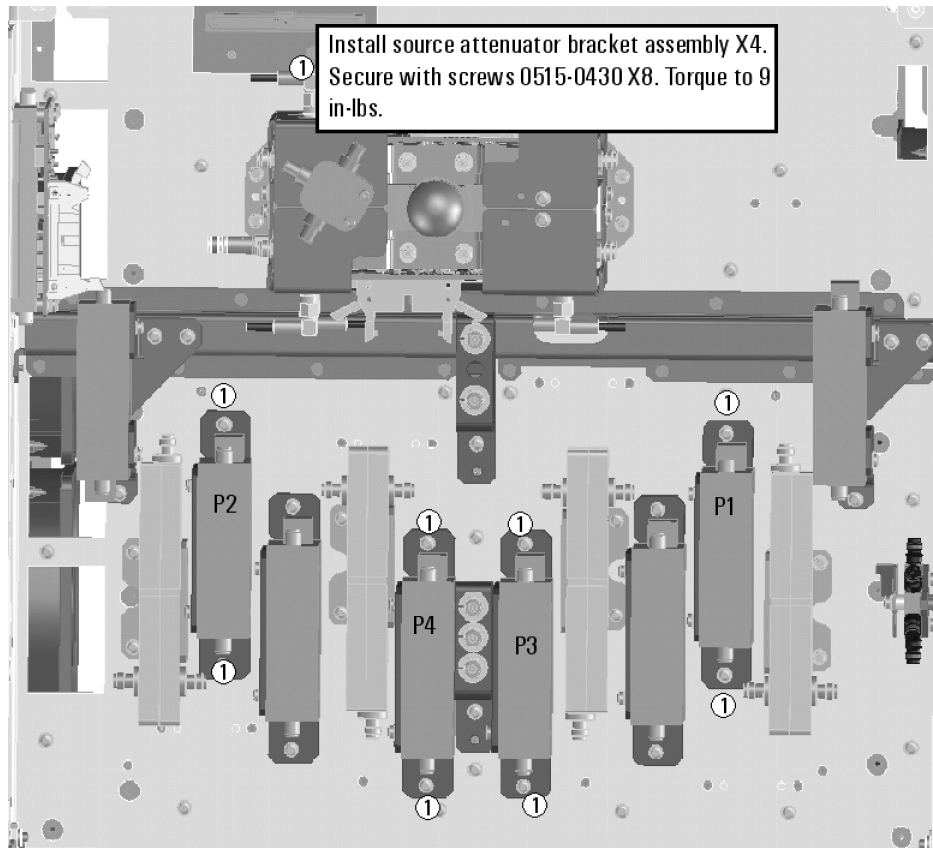

Step 10. Install Some Bottom-Side (Test Set) Cables

CAUTION Follow instructions carefully when making cable connections, especially wire harness connections. Incorrect connections can destroy components, resulting in additional customer costs.

Install the Semirigid Cables

To see an image showing the location of these cables, click the Chapter 6 bookmarks “Bottom RF Cables, 4-Port Configuration, Option 417” in the PDF Service Guide¹. New parts are listed in [Table 1 on page 7](#).

Install the following new cables in the order listed.

- W103 (N5245-20055) Port 2 RCVR B IN to A49 port 2 receiver attenuator
- W94 (N5245-20031) A41 port 2 source attenuator to front-panel Port 2 SOURCE OUT
- W33 (N5245-20010) A32 port 2 receiver coupler to front-panel REF 2 SOURCE OUT

* As shown in [Figure 7](#), install four clamps (part number 1400-1334) to secure W33.

Figure 7 Location of Cable Clamps for W33 (N5245-20010)

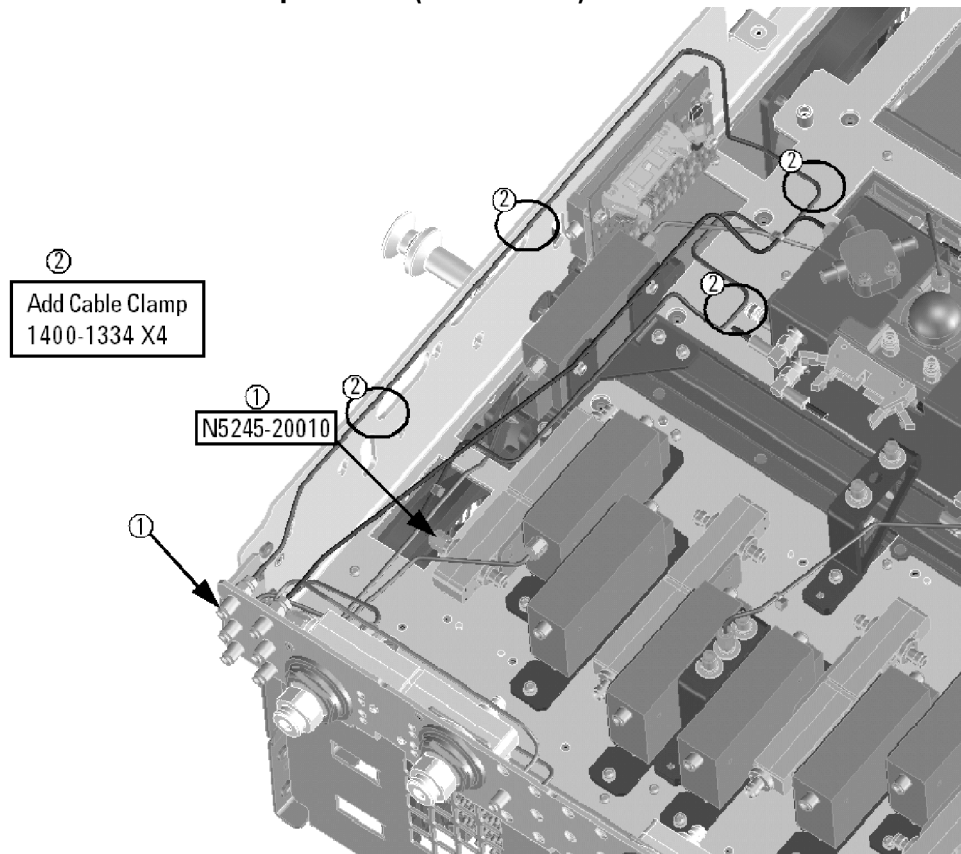

N5225 107 07

- W104 (N5245-20057) A49 port 2 receiver attenuator to A27 mixer brick (B)

1. See “[Downloading the Online PNA Service Guide](#)” on page 5.

- W47 (N5245-20115) REF 2 RCVR R2 IN to A27 mixer brick (R2)
- W101 (N5245-20074) Port 4 RCVR D IN to A48 port 4 receiver attenuator
- W45 (reuse) (N5245-20021) REF 4 RCVR R4 IN to 3 dB pad on A28 mixer brick (R4)
- W90 (N5245-20028) A40 port 4 source attenuator to front-panel Port 4 SOURCE OUT
- W102 (N5245-20075) A48 port 4 receiver attenuator to A28 mixer brick (D)
- W29 (N5245-20117) A31 port 4 receiver coupler to front-panel REF 4 SOURCE OUT

* As shown in **Figure 8**, install one clamp (part number 1400-1334) to secure W29.

Figure 8 Location of Cable Clamps for W29 (N5245-20117)

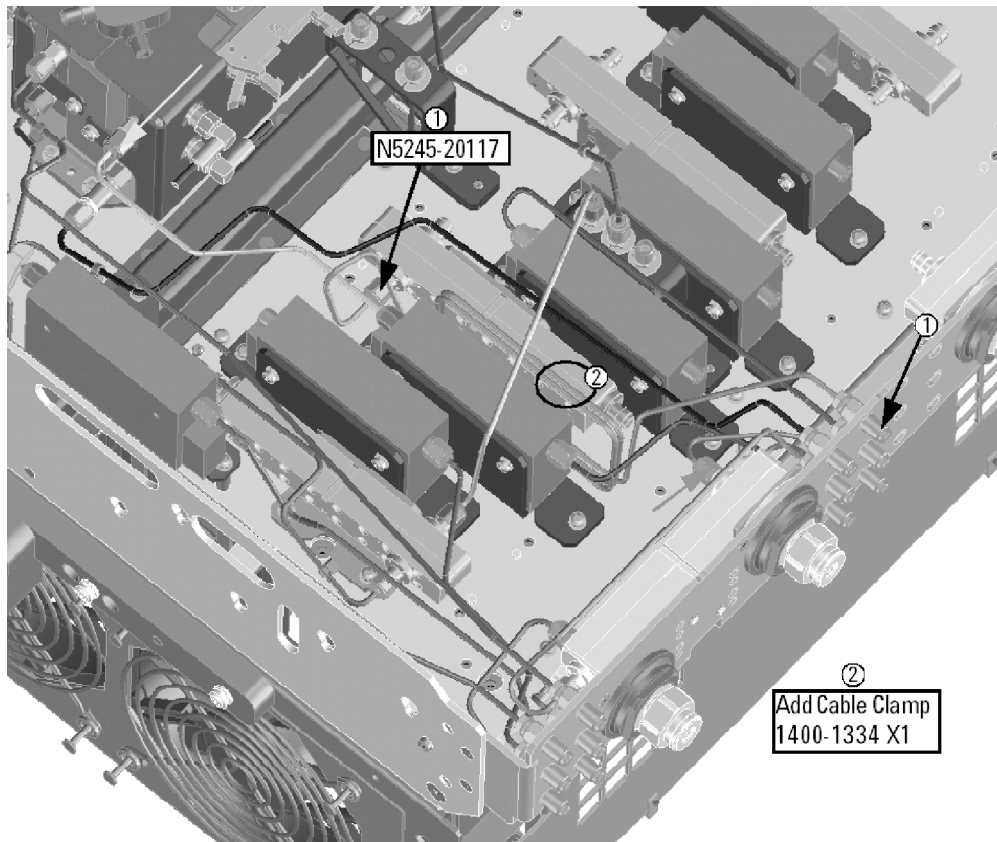

N5225_107_08

- W18 (N5245-20049) A32 port 2 receiver coupler to W17
- W85 (N5245-20026) A30 port 3 receiver coupler to A39 port 3 source attenuator
- W89 (N5245-20026) A31 port 4 receiver coupler to A40 port 4 source attenuator
- W99 (N5245-20073) Port 3 RCVR C IN to A47 port 3 receiver attenuator
- W86 (N5245-20027) A39 port 3 source attenuator to front-panel Port 3 SOURCE OUT
- W25 (N5245-20116) A30 port 3 receiver coupler to front-panel REF 3 SOURCE OUT

- W100 (N5245-20066) A47 port 3 receiver attenuator to A28 mixer brick (C)
 - W44 (reuse) (N5245-20020) REF 3 RCVR R3 IN to A28 mixer brick (R3)
- * As shown in **Figure 9**, install two cable ties (part number 1400-0249) to secure W25 and W44.

Figure 9 Location of Cable Ties for W25 and W44 (N5245-20116)

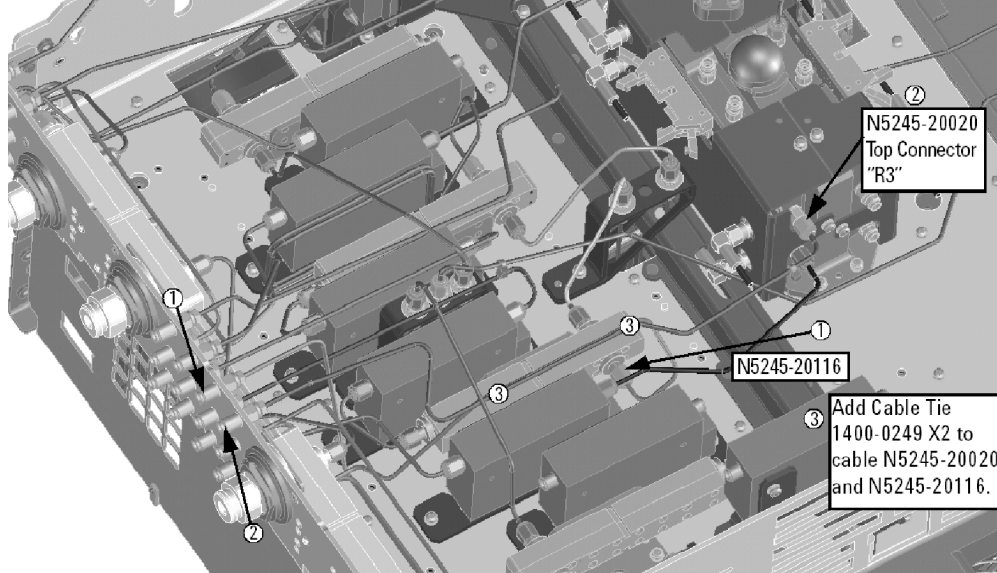

N5225_107_09

- W14 (reuse) (N5245-20043) A30 port 3 receiver coupler to W13
 - W16 (reuse) (N5245-20044) A31 port 4 receiver coupler to W15
 - W97 (N5245-20054) Front-panel Port 1 RCVR A IN to A46 port 1 receiver attenuator
 - W82 (N5245-20077) A38 port 1 source attenuator to front-panel Port 1 SOURCE OUT
 - W21 (N5245-20008) A29 port 1 receiver coupler to A37 reference mixer switch
- * As shown in **Figure 10**, install one cable tie (part number 1400-0249) and one clamp (part number 1400-1334) to secure W21.

Figure 10 Location of Cable Tie and Clamp for W21 (N5245-20008)

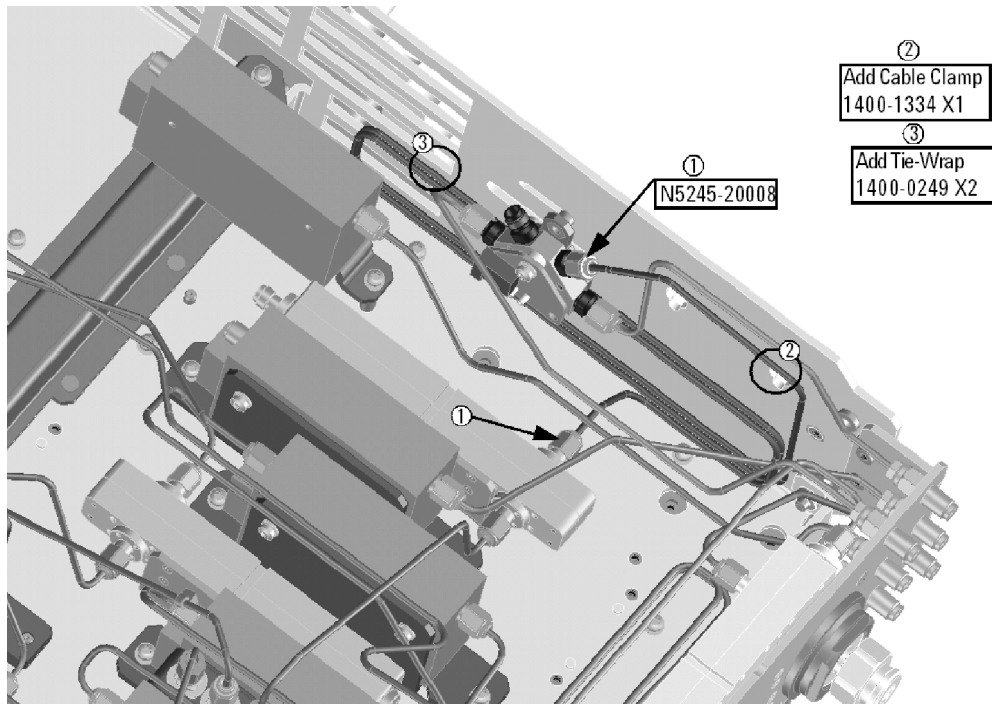

N5225_107_10

* If the screws that attach the reference mixer switch to the test set deck were loosened, torque these screws now to 9 in-lbs.

- W98 (N5245-20056) A46 port 1 receiver attenuator to A27 mixer brick (A)
- W81 (N5245-20029) A29 port 1 receiver coupler to A38 port 1 source attenuator
- W93 (N5245-20029) A32 port 2 receiver coupler to A41 port 2 source attenuator

Install the Ribbon Cables

To see an image showing the location of these cables, click the Chapter 6 bookmarks “Bottom Ribbon Cables and Wire Harnesses, 4-Port, Option 417” in the PDF Service Guide¹. New parts are listed in [Table 1 on page 7](#).

Connect step attenuator ribbon cables as follows:

- (N5245-60006) A38 port 1 source step attenuator to A23 test set motherboard J549
- (N5245-60006) A39 port 3 source step attenuator to A23 test set motherboard J547
- (N5245-60006) A40 port 4 source step attenuator to A23 test set motherboard J548
- (N5245-60006) A41 port 2 source step attenuator to A23 test set motherboard J546
- (N5245-60026) A46 port 1 receiver step attenuator to A23 test set motherboard J205
- (N5245-60026) A47 port 3 receiver step attenuator to A23 test set motherboard J206
- (N5245-60007) A48 port 4 receiver step attenuator to A23 test set motherboard J207

1. See [“Downloading the Online PNA Service Guide” on page 5](#).

- (N5245-60007) A49 port 2 receiver step attenuator to A23 test set motherboard J208.

Step 11. Remove the Old Lower Front Panel Overlay

Refer to **Figure 11** for this step of the procedure. New parts are listed in **Table 1 on page 7**.

1. From the back side of the front panel, use a blunt object in the cutouts in the lower front dress panel to push on the old overlay (item "1") and separate it from the front dress panel.
2. From the front side of the front panel, pull off the overlay completely and discard it.
3. Remove any adhesive remaining on the front panel.

Figure 11 Lower Front Panel Overlay Replacement

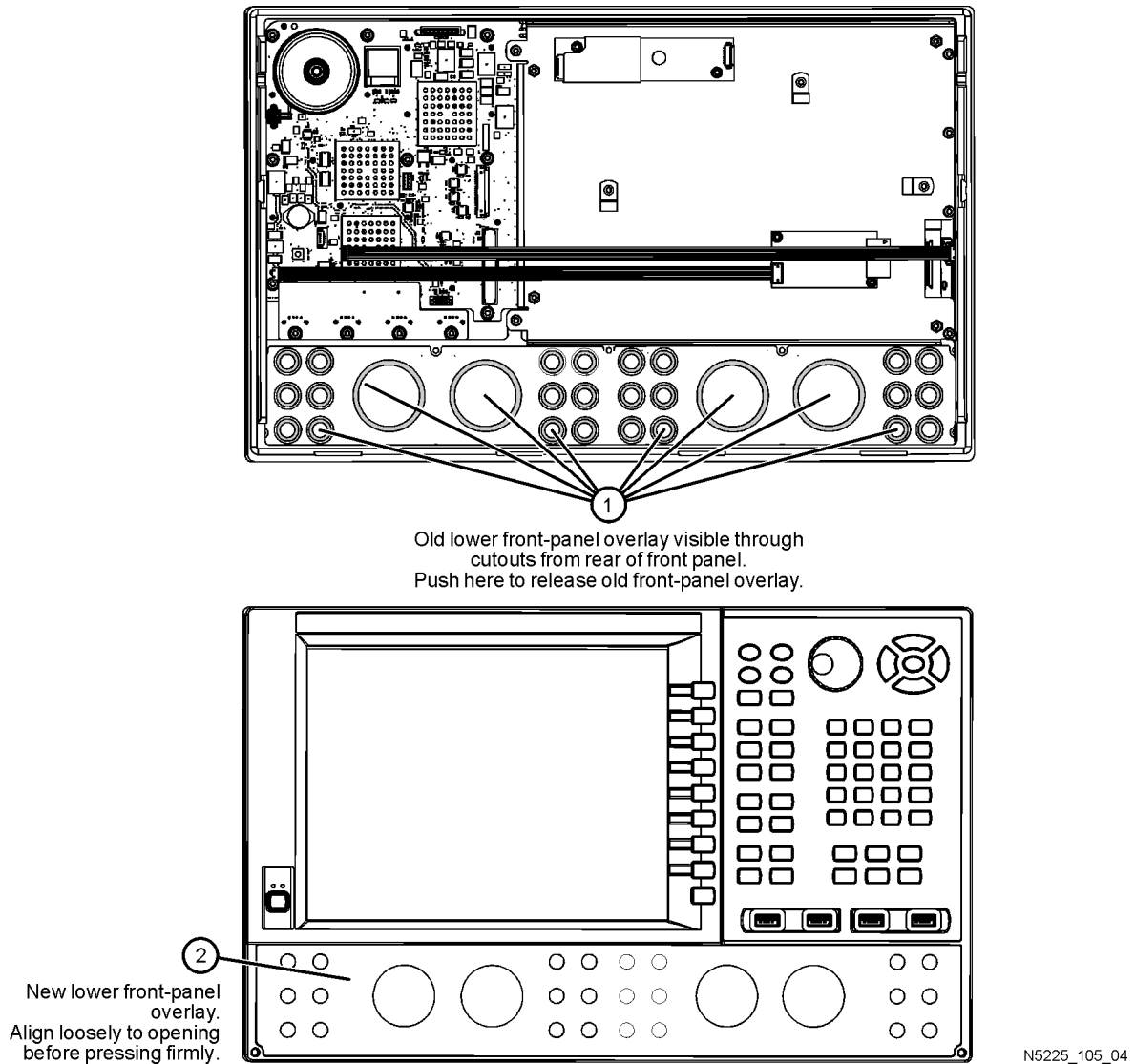

N5225_105_04

Step 12. Reinstall Front Panel Assembly

For instructions on reinstalling the front panel assembly, click the Chapter 7 bookmark “Removing and Replacing the Front Panel Assembly” in the PDF Service Guide¹.

Step 13. Install the New Lower Front Panel Overlay

Refer to [Figure 11 on page 22](#) for this step of the procedure. New parts are listed in [Table 1 on page 7](#).

1. Remove the protective backing from the new front panel overlay, N5225-80003 (item j).
2. Starting from either side, *loosely* place the overlay in the recess on the lower front panel, ensuring that it fits tightly against the edges of the recess.
3. Once the overlay is in place, press it firmly onto the frame to secure it.

Step 14. Reinstall Front Panel Jumpers

Reinstall all twelve of the front panel jumper cables (W36), part number N5245-20155. Torque to 10 in-lbs.

Step 15. Position the Cables and Wires to Prevent Pinching

On the top side of the PNA, carefully position the grey flex cables so they can't be pinched between the covers and the rails.

On the bottom side of the PNA, carefully fold or push down the ribbon cables and wires so they can't be pinched between the hardware and the outer cover. Ribbon cables and wires must never be positioned on top of hardware.

Step 16. Reinstall the Outer Cover

For instructions, click the Chapter 7 bookmark “Removing the Covers” in the PDF Service Guide¹.

Step 17. Enable Option 417

Procedure Requirements

- The analyzer must be powered up and operating to perform this procedure.
- The Network Analyzer program must be running.
- A keyboard must be connected to the network analyzer.

Option Enable Procedure

1. To start the option enable utility, press UTILITY **System**, then **Service**, then **Option Enable**. An option enable dialog box will appear.
2. Click the arrow in the **Select Desired Option** box. A list of available options will appear.
3. In the **Select Desired Option** list, click **417 - Configurable TS + Attens**.
4. Using the keyboard, enter the license key in the box provided. The license key is printed on the the license message you received from Keysight. Enter this key *exactly* as it is printed on the message.

5. Click **Enable**.
6. Click **Yes** in answer to the displayed question in the **Restart Analyzer?** box.
7. When the installation is complete, click **Exit**.

Option Verification Procedure

Once the analyzer has restarted and the Network Analyzer program is again running:

1. On the analyzer's **Help** menu, click **About Network Analyzer**.
2. Verify that "417" is listed after "Options:" in the display. Click **OK**.

NOTE If Option 417 has not been enabled, perform the "Option Enable Procedure" again. If the option is still not enabled, contact Keysight Technologies. Refer to "Getting Assistance from Keysight" on page 3.

Step 18. Perform Post-Upgrade Adjustments and Calibration

Adjustments

The following adjustments must be made due to the hardware changes of the analyzer.

- source adjustment
- receiver adjustment

These adjustments are described in the PNA Service Guide and in the PNA on-line HELP. A list of equipment required to perform these adjustments is also found in the service guide.

To view this service guide information, click the Chapter 3 bookmark "Tests and Adjustments" in the PDF Service Guide¹.

After the specified adjustments have been performed, the analyzer should operate and phase lock over its entire frequency range.

Operator's Check

Perform the Operator's Check to check the basic functionality of the analyzer. For instructions, click the Chapter 3 bookmark "Tests and Adjustments" in the PDF Service Guide¹.

If you experience difficulty with the basic functioning of the analyzer, contact Keysight. Refer to "Contacting Keysight" on page 3.

Calibration

Although the analyzer functions, its performance relative to its specifications has not been verified. It is recommended that a full instrument calibration be performed using the analyzer's internal performance test software. To view information on the performance test software, click the Chapter 3 bookmark "Tests and Adjustments" in the PDF Service Guide¹.

1. See "Downloading the Online PNA Service Guide" on page 5.

Step 19. Prepare the PNA for the User

1. If necessary, reinstall front jumper cables.
2. Install the cable guards, pushing them over the front jumper cables until the cushioning material touches the front panel of the PNA.
3. Install the dust caps on the test ports.
4. Clean the analyzer, as needed, using a damp cloth.

This information is subject to change without notice.
© Keysight Technologies 2011, 2013, 2014
August 2014



N5225-90107
www.keysight.com