

# Keysight Add 4-Port Capability Upgrade Kit

To Upgrade PNA N5224A or  
N5225A Option 219 to Option 419

Upgrade Kit Order Number:  
N5224AU-619 or N5225AU- 619

Keysight Kit Number: N5225-60114

NOTICE: This document contains references to Agilent Technologies. Agilent's former Test and Measurement business has become Keysight Technologies. For more information, go to [www.keysight.com](http://www.keysight.com).



---

## WARRANTY STATEMENT

THE MATERIAL CONTAINED IN THIS DOCUMENT IS PROVIDED "AS IS," AND IS SUBJECT TO BEING CHANGED, WITHOUT NOTICE, IN FUTURE EDITIONS. FURTHER, TO THE MAXIMUM EXTENT PERMITTED BY APPLICABLE LAW, KEYSIGHT DISCLAIMS ALL WARRANTIES, EITHER EXPRESS OR IMPLIED WITH REGARD TO THIS MANUAL AND ANY INFORMATION CONTAINED HEREIN, INCLUDING BUT NOT LIMITED TO THE IMPLIED WARRANTIES OF MERCHANTABILITY AND FITNESS FOR A PARTICULAR PURPOSE. KEYSIGHT SHALL NOT BE LIABLE FOR ERRORS OR FOR INCIDENTAL OR CONSEQUENTIAL DAMAGES IN CONNECTION WITH THE FURNISHING, USE, OR PERFORMANCE OF THIS DOCUMENT OR ANY INFORMATION CONTAINED HEREIN. SHOULD KEYSIGHT AND THE USER HAVE A SEPARATE WRITTEN AGREEMENT WITH WARRANTY TERMS COVERING THE MATERIAL IN THIS DOCUMENT THAT CONFLICT WITH THESE TERMS, THE WARRANTY TERMS IN THE SEPARATE AGREEMENT WILL CONTROL.

---

## DFARS/Restricted Rights Notice

If software is for use in the performance of a U.S. Government prime contract or subcontract, Software is delivered and licensed as "Commercial computer software" as defined in DFAR 252.227-7014 (June 1995), or as a "commercial item" as defined in FAR 2.101(a) or as "Restricted computer software" as defined in FAR 52.227-19 (June 1987) or any equivalent agency regulation or contract clause. Use, duplication or disclosure of Software is subject to Keysight Technologies' standard commercial license terms, and non-DOD Departments and Agencies of the U.S. Government will receive no greater than Restricted Rights as defined in FAR 52.227-19(c)(1-2) (June 1987). U.S. Government users will receive no greater than Limited Rights as defined in FAR 52.227-14 (June 1987) or DFAR 252.227-7015 (b)(2) (November 1995), as applicable in any technical data.

---

## Safety Notes

The following safety notes are used throughout this document. Familiarize yourself with each of these notes and its meaning before performing any of the procedures in this document.

---

**WARNING**      **Warning denotes a hazard. It calls attention to a procedure which, if not correctly performed or adhered to, could result in injury or loss of life. Do not proceed beyond a warning note until the indicated conditions are fully understood and met.**

---

---

**CAUTION**      Caution denotes a hazard. It calls attention to a procedure that, if not correctly performed or adhered to, could result in damage to or destruction of the instrument. Do not proceed beyond a caution sign until the indicated conditions are fully understood and met.

---

---

## Description of the Upgrade

This upgrade converts your N5224A or N5225A Option 219 2-port analyzer to an N5224A or N5225A Option 419 4-port analyzer by adding:

- an additional 26.5 GHz source board
- an additional 13.5 GHz source synthesizer board
- two additional 40 GHz doublers
- an additional mixer brick
- two additional receiver couplers and brackets
- two additional test port couplers
- two additional bias tees and brackets
- two additional source attenuators and brackets
- two additional receiver attenuators and brackets
- an additional cable guard for front panel jumpers
- a splitter
- a 3 dB pad
- a modified front panel
- new cables

---

## Getting Assistance from Keysight

Installing this upgrade kit requires special skills and experience. If you think you may not be qualified to do the work, or need advice, contact Keysight.

### Contacting Keysight

Assistance with test and measurements needs and information on finding a local Keysight office are available on the Web at:

<http://www.keysight.com/find/assist>

If you do not have access to the Internet, please contact your Keysight field engineer.

---

**NOTE** In any correspondence or telephone conversation, refer to the Keysight product by its model number and full serial number. With this information, the Keysight representative can determine whether your product is still within its warranty period.

---

---

## Getting Prepared

---

**CAUTION** The PNA contains extremely sensitive components that can be ruined if mishandled. Follow instructions carefully when making cable connections, especially wire harness connections.

The person performing the work accepts responsibility for the full cost of the repair or replacement of damaged components.

---

To successfully install this upgrade kit, you will need the following:

- A license key - refer to “[License Key Redemption](#)” below.
- A PDF copy or a paper copy of the PNA Service Guide - refer to “[Downloading the Online PNA Service Guide](#)” below.
- An ESD-safe work area - refer to “[Protecting Your Workspace from Electrostatic Discharge](#)” below.
- Correct tools - refer to “[Tools Required for the Installation](#)” on page 5.
- Enough time - refer to “[About Installing the Upgrade](#)” on page 6.
- Test equipment for the post-upgrade adjustments and full instrument calibration. To view the equipment list, click the Chapter 3 bookmark “[Tests and Adjustments](#)” in the PDF Service Guide<sup>1</sup>.

## License Key Redemption

---

**NOTE** The enclosed Option Entitlement Certificate is a receipt, verifying that you have purchased a licensed option for the PNA of your choice. You must now use a Keysight Web page to request a license key for the instrument that will receive the option.

---

To enable the option product, you must request a license key from: <http://www.keysight.com/find/softwarelicense>. To complete the request, you will need to gather the following information:

- From the certificate
  - Order number
  - Certificate number
- From your instrument
  - Model number
  - Serial number
  - Host ID

The instrument information is available on the network analyzer – on the analyzer’s **Help** menu, click **About Network Analyzer**.

If you provide an email address, Keysight will promptly email your license key. Otherwise, you will receive your license key via postal mail.

---

1. See “[Downloading the Online PNA Service Guide](#)” on page 5.

## Downloading the Online PNA Service Guide

To view the online Service Guide for your PNA model number, use the following steps:

1. Go to [www.keysight.com](http://www.keysight.com).
2. In the Search box, enter the model number of the analyzer (Ex: N5225A) and click **Search**.
3. Click **Technical Support > Manuals**.
4. Click **Service Manual**.
5. Click the service guide title to download the PDF file.
6. When the PDF of the Service Guide is displayed, scroll through the Contents section bookmarks to locate the information needed.

## Protecting Your Workspace from Electrostatic Discharge

For information, click on the Chapter 1 bookmark, "Electrostatic Discharge Protection" in the PDF Service Guide<sup>1</sup>.

### ESD Equipment Required for the Installation

Description	Keysight Part Number
ESD grounding wrist strap	9300-1367
5-ft grounding cord for wrist strap	9300-0980
2 x 4 ft conductive table mat and 15-ft grounding wire	9300-0797
ESD heel strap (for use with conductive floors)	9300-1308

### Customer Order No. Tools Required for the Installation

Description	Qty	Part Number
T-6 TORX driver - set to 4 in-lbs (0.45 N.m)	1	N/A
T-8 TORX driver - set to 6 in-lbs (0.68 N.m)	1	N/A
T-10 TORX driver - set to 9 in-lbs (1.02 N.m)	1	N/A
T-20 TORX driver - set to 21 in-lbs (2.38 N.m)	1	N/A
5/16-in (8 mm) nutsetter or open end torque wrench- set to 10 in-lbs (1.13 N.m)	1	N/A
3/16-in (5 mm) nutsetter or open end torque wrench - set to 6 in-lbs (0.68 N.m)	1	N/A
5/8-in (16 mm) nutsetter or open end torque wrench - set to 21 in-lbs (2.38 N.m)	1	N/A
9 mm nutsetter or open end torque wrench - set to 21 in-lbs (2.38 N.m)	1	N/A
1-in (25.4 mm) torque wrench - set to 72 in-lbs (8.15 N.m)	1	N/A

**CAUTION** Use a 5/16-in torque wrench set to 10 in-lbs on all cable connections except the front and rear panel bulkhead connectors. On these, use a 9 mm nutsetter or open end torque wrench set to 21 in-lb.

1. See "Downloading the Online PNA Service Guide" on page 5.

## About Installing the Upgrade

Products affected . . . . .	N5224A or N5225A Option 219
Installation to be performed by . . . . .	Keysight service center or personnel qualified by Keysight
Estimated installation time . . . . .	5 hours
Estimated adjustment time . . . . .	0.5 hours
Estimated full instrument calibration time . . . . .	4.5 hours

## Items Included in the Upgrade Kit<sup>1</sup>

Check the contents of your kit against the following list. If any part is missing or damaged, contact Keysight Technologies. Refer to [“Contacting Keysight” on page 3](#).

**Table 1 Contents of Upgrade Kit N5225-60114**

Ref Desig.	Description	Qty	Part Number
-	Installation note (this document)	1	N5225-90124
A10	26.5 GHz source (2) board	1	5087-7342
A12	40 GHz doubler assembly port 3	2	5087-7349
A13	40 GHz doubler assembly port 4		
A17	13.5 GHz (source 2) synthesizer board	1	N5240-60074 Was N5242-60150
A26	Splitter	1	5067-4086
A28	Mixer brick (2)	1	5087-7323
A30	Test port 3 reference coupler	2	5087-7760
A31	Test port 4 reference coupler		
A34	Test port 3 coupler	2	5087-7793
A35	Test port 4 coupler		
A39	Test port 3 source attenuator	2	33325-60016
A40	Test port 4 source attenuator		
A43	Test port 3 bias tee	2	5087-7789
A44	Test port 4 bias tee		
A47	Test port 3 receiver attenuator	2	33325-60017
A48	Test port 4 receiver attenuator		
-	Front frame, 4-port	1	N5247-20141
-	Machine screw, M3.0 x 6, flat head (to attach front frame to coupler plate)	3	0515-1946
-	Machine screw, M3.0 x 14, pan head (to attach bias tee to bracket)	6	0515-0665
-	Machine screw, M2.0 x 6, flat head (8 to attach two reference couplers to brackets)	10	0515-1602
-	Machine screw, M2.5 x 20, pan head (4 to attach A34 and A35 reference coupler assemblies to test set deck)	5	0515-0374
-	Machine screw, M4.0 x 10, pan head (2 each to attach the following boards to the analyzer chassis: A17 13.5 GHz synthesizer board, A10 26.5 GHz source board, A12 40 GHz doubler assembly port 3, and A13 40 GHz doubler assembly port 4.)	10	0515-0380
-	Machine screw, M3.0 x 6, pan head (4 to attach A47 and A48 receiver attenuator assembly to test set deck; 4 to attach A39 and A40 source attenuator assembly to test set deck.	5	0515-0430
-	Machine screw, M3.0 x 12, pan head (1 to attach cable bracket to test set deck.	2	0515-0664

1. In addition to the upgrade kit, the shipment includes an Option Entitlement Certificate. Refer to [“License Key Redemption” on page 4](#) for important information about this certificate.



**Table 1 Contents of Upgrade Kit N5225-60114**

<b>Ref Desig.</b>	<b>Description</b>	<b>Qty</b>	<b>Part Number</b>
-	Machine screw, M3.0 x 8, pan head (3 to attach shield to A28 mixer brick; 8 to attach two src attn and two rcvr attn to brackets; 4 to attach bias tee brackets to deck)	14	0515-0372
-	Machine screw, M2.5 x 16, pan head (2 to attach splitter to mixer brick)	3	0515-2007
-	Machine screw, M3.0 x 25, pan head (3 to attach A28 mixer brick to block)	4	0515-0667
-	Machine screw, M3.0 x 20, flat head (2 to attach bracket to A10 26.5 GHz source)	3	0515-2078
-	Machine screw, M3.0 x 18, pan head (1 to attach bracket to A10 26.5 GHz source)	2	0515-0666
-	Front panel overlay (label), 4-port	1	N5227-80005
-	Keypad overlay (label)	1	N5242-80005
-	Power button overlay (label)	1	N5242-80007
-	Nameplate, N5224A	1	N5224-80001
-	Nameplate, N5225A	1	N5225-80001
-	Test set front plate, 4-port	1	N5224-00005
-	2.4 mm dust cap for A28 mixer brick	1	N5247-20138
-	Gap pad (between mixer brick A28 and shield)	4	N5245-20125
-	Gap pad (between each test coupler and the test set front plate)	4	E4403-20033
-	Shield, mixer brick	1	N5245-00023
A69	3 dB pad, attached to R4 connector on A28 mixer brick	1	08490-60039
-	50 ohm load, attached to A13 40 GHz doubler	1	1810-0118
-	Vibration mount (between couplers 1 & 3, and 2 & 4)	2	0460-2725
-	Mounting nuts (for port 3 & 4 test port couplers)	2	5022-1087
-	Cable guard, center jumper cables	1	N5242-00030
-	Cable clamp, 1 to secure W25 (N5245-20116); 1 to secure W29 (N5245-20117).	6	1400-1334
-	Cable tie wrap, 1 to secure W44 (N5245-20020); 1 to secure W21 (N5245-20008).	6	1400-0249
-	Bracket for bias tee	2	N5245-00011
-	Bracket for reference coupler	2	N5245-00017
-	Bracket for cables	1	N5245-00022
-	Bracket for receiver attenuator and source attenuator	4	N5245-00015
-	Bracket for A10 26.5 GHz source (2) board	1	N5247-20136
W2	RF cable, A10 source (2) P1 to A17 13.5 GHz source (2) synthesizer J1207 (4-port)	1	N5245-20100
W7	RF cable, A10 source (2) P5 to A12 port 3 doubler	1	N5245-20034
W8	RF cable, A10 source (2) P3 to A13 port 4 doubler	1	N5245-20035
W9	RF cable, A10 source (2) P4 to A12 port 3 doubler	1	N5245-20032
W10	RF cable, A12 port 3 doubler to A13 port 4 doubler	1	N5245-20033
W13	RF cable, A12 port 3 doubler to W14	1	N5245-20036
W14	RF cable, A30 port 3 receiver coupler to W13	1	N5245-20043
W15	RF cable, A13 port 4 doubler to W16	1	N5245-20036

**Table 1 Contents of Upgrade Kit N5225-60114**

<b>Ref Desig.</b>	<b>Description</b>	<b>Qty</b>	<b>Part Number</b>
W16	RF cable, A31 port 4 receiver coupler to W15	1	N5245-20044
W21	RF cable, A29 port 1 receiver coupler to A37 reference mixer switch	1	N5245-20008
W22	RF cable, A33 port 1 coupler to front-panel Port 1 CPLR ARM	1	N5245-20014
W25	RF cable, A30 port 3 receiver coupler to front-panel REF 3 SOURCE	1	N5245-20116
W26	RF cable, A34 port 3 coupler to front-panel Port 3 CPLR ARM	1	N5245-20015
W29	RF cable, A31 port 4 receiver coupler to front-panel REF 4 SOURCE	1	N5245-20117
W30	RF cable, A35 port 4 coupler to front-panel Port 4 CPLR ARM	1	N5245-20018
W34	RF cable, A36 port 2 coupler to front-panel Port 2 CPLR ARM	1	N5245-20019
W36	RF cable, Front panel jumper	6	N5245-20155
W44	RF cable, REF 3 RCVR R3 IN to A28 mixer brick (R3)	1	N5245-20020
W45	RF cable, REF 4 RCVR R4 IN to A69 3 dB pad on A28 mixer brick (R4)	1	N5245-20021
W47	RF cable, REF 2 RCVR R2 IN to A27 mixer brick (R2)	1	N5245-20115
W52	RF cable, A25 HMA26.5 to A26 splitter	1	N5245-20013
W53	RF cable, A26 splitter to A27 mixer brick	1	N5245-20023
W54	RF cable, A26 splitter to A28 mixer brick	1	N5245-20022
W62	RF cable, A27 mixer brick (R1) to A24 IF multiplexer (P411)	1	N5242-60021
W63	RF cable, A27 mixer brick (R2) to A24 IF multiplexer (P412)	1	N5242-60022
W65	RF cable, A28 mixer brick (D) to A24 IF multiplexer (P801)	1	N5242-60024
W66	RF cable, A28 mixer brick (R4) to A24 IF multiplexer (P414)	1	N5242-60019
W67	RF cable, A28 mixer brick (R3) to A24 IF multiplexer (P413)	1	N5242-60020
W68	RF cable, A28 mixer brick (C) to A24 IF multiplexer (P601)	1	N5242-60023
W70	RF cable, A24 IF multiplexer board P203 to A16 SPAM board J2	1	N5242-60013
W72	RF cable, A24 IF multiplexer board P603 to A16 SPAM board J5	1	N5242-60015
W77	RF cable, A14 frequency reference board J7 to A17 13.5 GHz (source 2) synthesizer board J5 (Located on bottom of board.)	1	N5242-60030
W84	RF cable, A33 port 1 coupler to A42 port 1 bias tee	1	N5245-20085
W85	RF cable, A30 port 3 receiver coupler to A39 port 3 source attenuator	1	N5245-20026
W86	RF cable, A39 port 3 source attenuator to front-panel Port 3 SOURCE OUT	1	N5245-20027
W87	RF cable, Port 3 CPLR THRU to A43 port 3 bias tee	1	N5245-20089
W88	RF cable, A43 port 3 bias tee to A34 port 3 coupler	1	N5245-20086
W89	RF cable, A31 port 4 receiver coupler to A40 port 4 source attenuator	1	N5245-20026
W90	RF cable, A40 port 4 source attenuator to front-panel Port 4 SOURCE OUT	1	N5245-20028
W91	RF cable, Port 4 CPLR THRU to A44 port 4 bias tee	1	N5245-20090
W92	RF cable, A44 port 4 bias tee to A35 port 4 coupler	1	N5245-20088
W96	RF cable, A45 port 2 bias tee to A36 port 2 coupler	1	N5245-20087
W99	RF cable, Port 3 RCVR C IN to A47 port 3 receiver attenuator	1	N5245-20073
W100	RF cable, A47 port 3 receiver attenuator to A28 mixer brick (C)	1	N5245-20066

**Table 1 Contents of Upgrade Kit N5225-60114**

<b>Ref Desig.</b>	<b>Description</b>	<b>Qty</b>	<b>Part Number</b>
W101	RF cable, Port 4 RCVR D IN to A48 port 4 receiver attenuator	1	N5245-20074
W102	RF cable, A48 port 4 receiver attenuator to A28 mixer brick (D)	1	N5245-20075
-	Ribbon cable, A23 test set motherboard J547 to A39 port 3 source attenuator	2	N5245-60006
-	Ribbon cable, A23 test set motherboard J548 to A40 port 4 source attenuator		
-	Ribbon cable, A23 test set motherboard J206 to A47 port 3 receiver attenuator	2	N5245-60026 Was 8121-0982, or N5242-60007
-	Ribbon cable, A23 test set motherboard J207 to A48 port 4 receiver attenuator		
-	Ribbon cable, A23 test set motherboard J552 to A28 mixer brick (2) J52	1	N5247-60015
-	Wire harness, A43 port 3 bias tee to A23 test set motherboard J543	2	P/O bias tee
-	Wire harness, A44 port 4 bias tee to A23 test set motherboard J544		

---

**NOTE** Extra quantities of items such as protective plastic caps, screws, cable ties, and cable clamps may be included in this upgrade kit. It is normal for some of these items to remain unused after the upgrade is completed.

---

---

## Installation Procedure for the Upgrade

The network analyzer must be in proper working condition prior to installing this option. Any necessary repairs must be made before proceeding with this installation.

---

**WARNING**      **This installation requires the removal of the analyzer's protective outer covers. The analyzer must be powered down and disconnected from the mains supply before performing this procedure.**

---

### Overview of the Installation Procedure

Step 1. Obtain a Keyword and Verify the Information.

Step 2. Remove the Outer Cover.

Step 3. Remove the Inner Cover.

Step 4. Remove the Front Panel Assembly.

Step 5. Remove the A23 Test Set Motherboard.

Step 6. Remove Some Bottom-Side (Test Set) Cables.

Step 7. Remove the A27 Mixer Brick Assembly.

Step 8. Assemble the A28 Mixer Brick Assembly.

Step 9. Install the A27/A28 Mixer Brick Assemblies.

Step 10. Assemble the A34 and A35 Reference Coupler Assemblies.

Step 11. Install the A34 and A35 Reference Coupler Assemblies.

Step 12. Assemble the A47 and A48 Receiver Attenuator Assemblies.

Step 13. Install the A47 and A48 Receiver Attenuator Assemblies.

Step 14. Assemble the A39 and A40 Source Attenuator Assemblies.

Step 15. Install the A39 and A40 Source Attenuator Assemblies.

Step 16. Install the Bias Tee Brackets.

Step 17. Install the A43 and A44 Bias Tees.

Step 18. Assemble the A33 - A36 Test Port Coupler Assemblies.

Step 19. Install the LED Boards, Bulkhead Connectors, and Test Port Coupler Assemblies to the 4-Port Test Set Front Plate.

Step 20. Install the 4-Port Coupler Plate Assembly to the Deck.

Step 21. Assemble and Install the A12 and A13 40 GHz Doubler Assemblies.

Step 22. Install Bracket to A10 Source Assembly.

Step 23. Assemble the A10 26.5 GHz Source 2 Assembly.

Step 24. Install the A10 26.5 GHz Source 2 Assembly and Cables.

- Step 25. Install the A17 13.5 GHz (Source 2) Synthesizer Board and Cables.
- Step 26. Install the Cable Bracket Mount.
- Step 27. Install Some Bottom-Side (Test Set) Cables.
- Step 28. Secure the Front Panel Bulkhead Connectors.
- Step 29. Install Cables on IF Multiplexer Board.
- Step 30. Reinstall the A23 Test Set Motherboard.
- Step 31. Install Cables on the A23 Test Set Motherboard.
- Step 32. Replace the Front Frame in the Front Panel Assembly.
- Step 33. Reinstall Front Panel Assembly.
- Step 34. Install the Overlays and Nameplate.
- Step 35. Install the Front Panel Jumper Cables.
- Step 36. Position the Cables and Wires to Prevent Pinching.
- Step 37. Reinstall the Inner Cover.
- Step 38. Reinstall the Outer Cover.
- Step 39. Remove Option 219 License.
- Step 40. Enable Options P04 (400) and 419.
- Step 41. Perform Post-Upgrade Adjustments and Calibration.
- Step 42. Prepare the PNA for the User.

## Step 1. Obtain a Keyword and Verify the Information

Follow the instructions on the Option Entitlement Certificate supplied to obtain a license key for installation of this upgrade. Refer to [“License Key Redemption” on page 4](#).

Verify that the model number, serial number, and option number information on the license key match those of the instrument on which this upgrade will be installed.

If the model number, serial number, or option number do not match those on your license key, you will not be able to install the option. If this is the case, contact Keysight for assistance before beginning the installation of this upgrade. Refer to [“Contacting Keysight” on page 3](#).

Once the license key has been received and the information verified, you can proceed with the installation at step 2.

## Step 2. Remove the Outer Cover

For instructions, click the Chapter 7 bookmark [“Removing the Covers”](#) in the PDF Service Guide<sup>1</sup>.

## Step 3. Remove the Inner Cover

For instructions, click the Chapter 7 bookmark [“Removing the Covers”](#) in the PDF Service Guide<sup>1</sup>.

## Step 4. Remove the Front Panel Assembly

For instructions, click the Chapter 7 bookmark [“Removing and Replacing the Front Panel Assembly”](#) in the PDF Service Guide<sup>1</sup>.

## Step 5. Remove the A23 Test Set Motherboard

For instructions, click the Chapter 7 bookmark [“Removing and Replacing the A23 Test Set Motherboard”](#) in the PDF Service Guide<sup>1</sup>.

## Step 6. Remove Some Bottom-Side (Test Set) Cables

---

**CAUTION** Be careful not to damage the center pins of the semirigid cables. Some flexing of the cables may be necessary but do not over-bend them.

---

---

**NOTE** When removing a cable, also remove the plastic cable clamp, if present. It is normal for some of the cable clamp’s adhesive to remain.

---

1. Place the analyzer bottom-side up on a flat surface.

Remove the following cables. To see an image showing the location of these cables, click the Chapter 6 bookmark [“Bottom RF Cables, Standard 2-Port Configuration, Option 219”](#) in the PDF Service Guide<sup>1</sup>.

These cables may be discarded - they will not be reinstalled.

---

1. See [“Downloading the Online PNA Service Guide” on page 5](#).

- W21 (N5245-20118) A29 port 1 receiver coupler to A37 reference mixer switch
- W22 (N5245-20025) A33 port 1 coupler to front-panel REF 1 CPLR ARM
- W34 (N5245-20024) A36 port 2 coupler to front-panel REF 2 CPLR ARM
- W47 (N5245-20119) A27 mixer brick (R2) to front-panel REF 2 RCVR R2 IN
- W62 (N5242-60025) A27 mixer brick (R1) to A24 IF multiplexer (P601)
- W63 (N5242-60026) A27 mixer brick (R2) to A24 IF multiplexer (P801)
- W70 (N5247-60024) A24 IF multiplexer board P203 to A16 SPAM board J5
- W72 (N5247-60023) A24 IF multiplexer board P603 to A16 SPAM board J2
- W80 (N5245-20048) A25 HMA26.5 to A27 mixer brick
- W84 (N5245-20046) A33 port 1 coupler to A42 port 1 bias tee
- W96 (N5245-20047) A36 port 2 coupler to A45 port 2 bias tee

These cables must be saved - they will be reinstalled.

- W12 (N5245-20050) A29 port 1 receiver coupler to W11
- W18 (N5245-20049) A32 port 2 receiver coupler to W17
- W36 (N5245-20155) Front panel jumpers (quantity = 6)

**NOTE:** Remove and save the cable guards for the front panel jumpers.

### **Step 7. Remove the A27 Mixer Brick Assembly**

Remove the A27 mixer brick assembly from the PNA. For instructions, click the Chapter 7 bookmark, “Removing and Replacing the A27 and A28 Mixer Bricks” in the PDF Service Guide<sup>1</sup>.

## Step 8. Assemble the A28 Mixer Brick Assembly

1. Follow the instruction shown in [Figure 1](#). New parts are listed in [Table 1 on page 7](#) of this document.

**Figure 1** A28 Mixer Brick Assembly

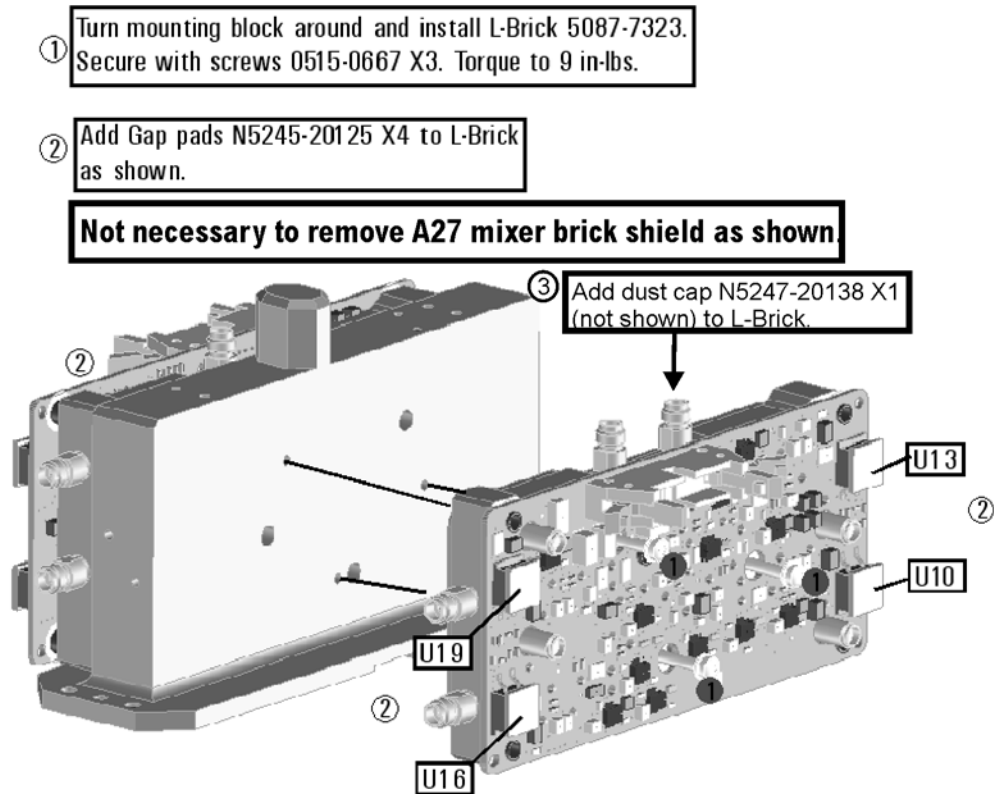

N5225\_124\_04



2. Follow the two instructions shown in **Figure 2**.

**Figure 2     A28 Mixer Brick Shield Installation**

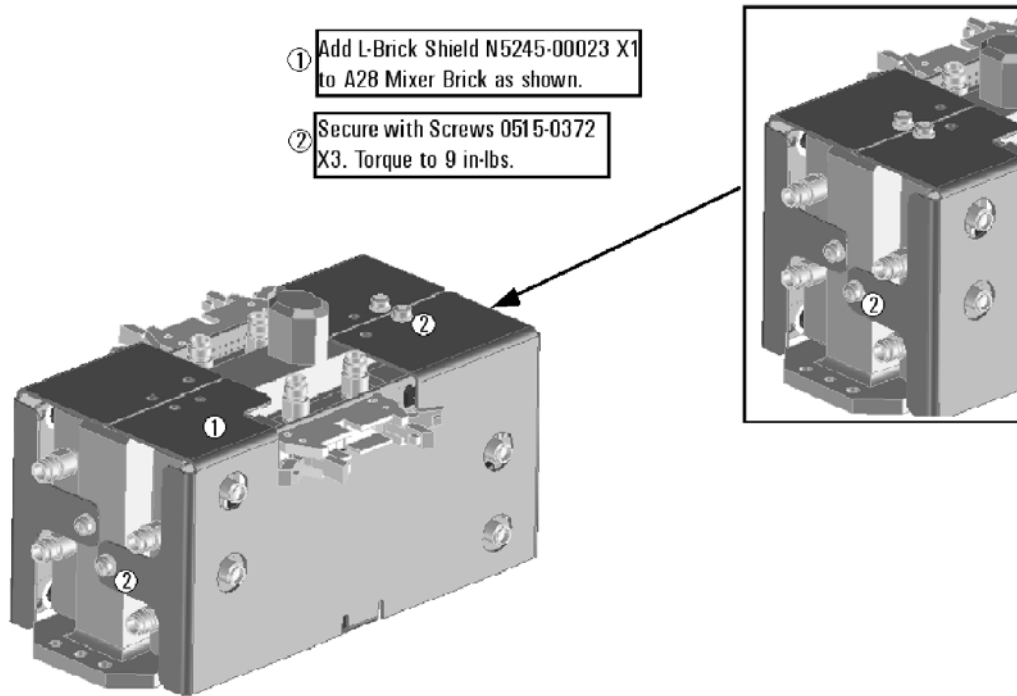

N5225\_124\_05

3. Follow the two instructions shown in **Figure 3**.

**Figure 3 A69 3 dB Pad and A26 Splitter Installation**

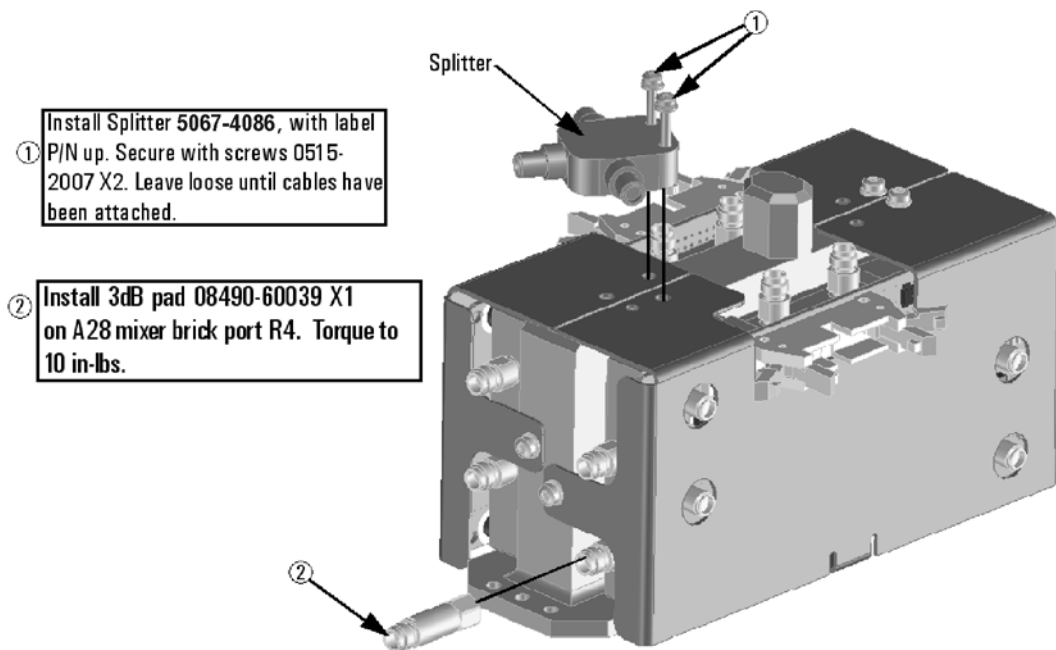

N5225\_124\_06

4. Connect the gray flexible cables to the A28 mixer in the order shown in [Figure 4](#). The other ends of the cables will be connected when the IF board is reinstalled later.

**Figure 4 A28 Mixer Brick Cable Installation**

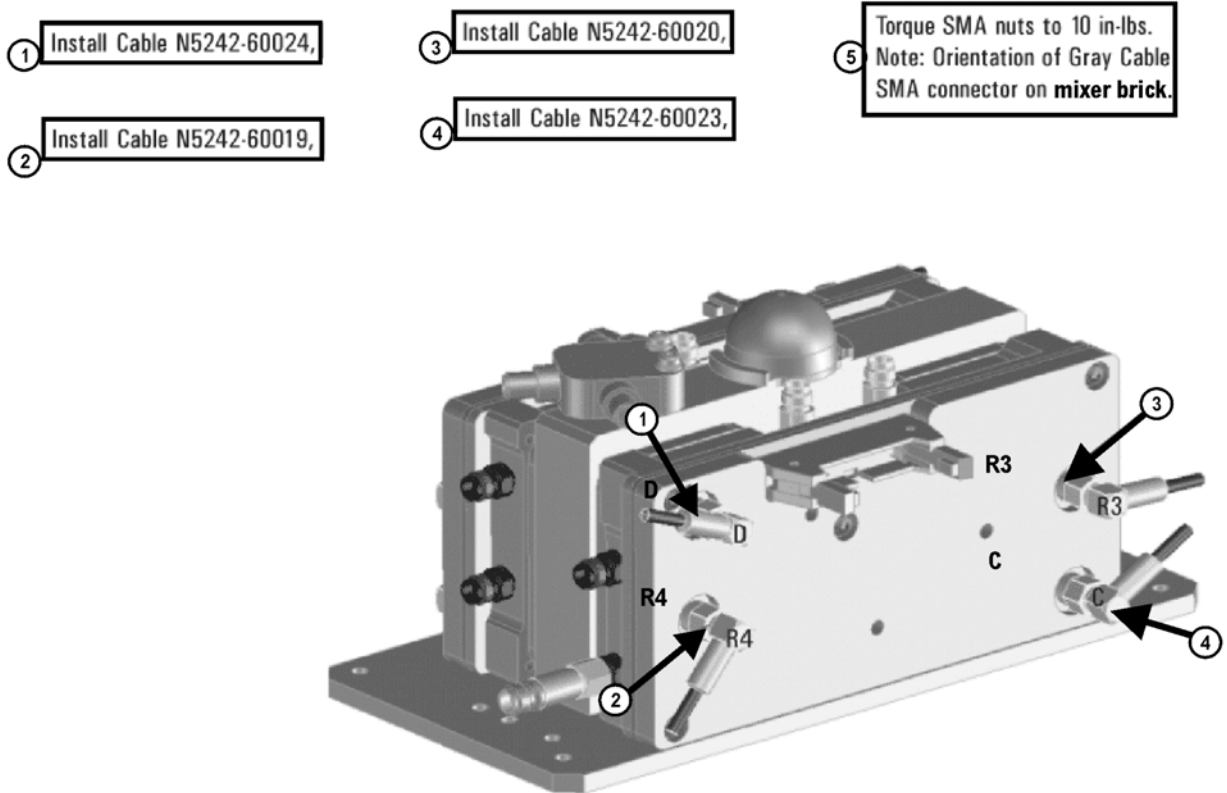

N5225\_124\_07

### Step 9. Install the A27/A28 Mixer Brick Assemblies

Reinstall the A27 mixer brick cables, and then install the A27/A28 mixer brick assembly, reusing the four existing screws. For instructions, click the Chapter 7 bookmark, "Removing and Replacing the A27 and A28 Mixer Bricks" in the PDF Service Guide<sup>1</sup>. New parts are listed in [Table 1 on page 7](#) of this document.

1. See "[Downloading the Online PNA Service Guide](#)" on page 5.

## Step 10. Assemble the A34 and A35 Reference Coupler Assemblies

Follow the instructions shown in [Figure 5](#) and [Figure 6](#). New parts are listed in [Table 1 on page 7](#) of this document.

**Figure 5** A34 Reference Coupler Port 3 Assembly

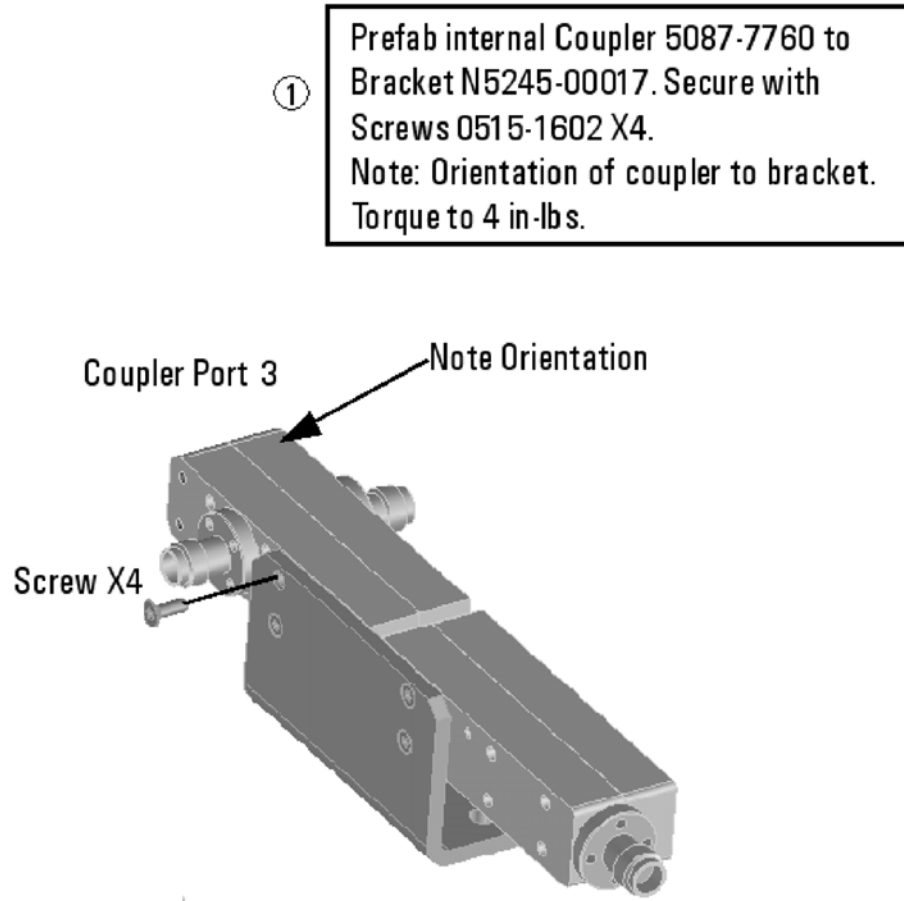

N5225\_124\_09

**Figure 6     A35 Reference Coupler Port 4 Assembly**

① Prefab internal Coupler 5087-7760 to Bracket N5245-00017. Secure with Screws 0515-1602 X4.  
Note orientation of coupler to bracket. Torque to 4 in-lbs.

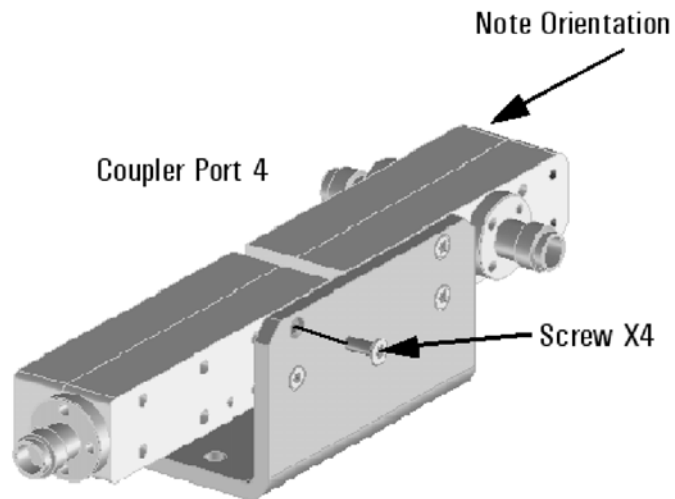

N5225\_124\_11

## Step 11. Install the A34 and A35 Reference Coupler Assemblies

Follow the instructions shown in [Figure 7](#). New parts are listed in [Table 1 on page 7](#) of this document.

**Figure 7** A34 and A35 Reference Coupler Assemblies Installation

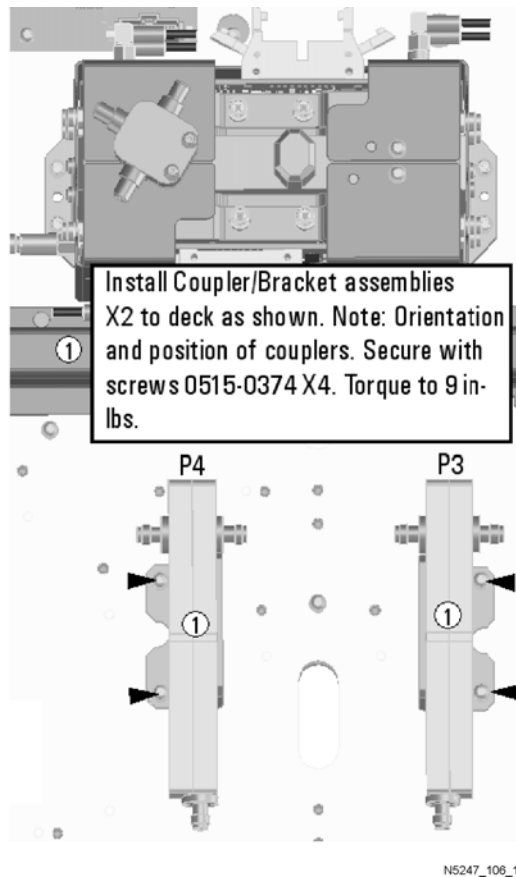

## Step 12. Assemble the A47 and A48 Receiver Attenuator Assemblies

Follow the instructions shown in [Figure 8](#). New parts are listed in [Table 1 on page 7](#) of this document.

**Figure 8** A47 and A48 Receiver Attenuators Assembly

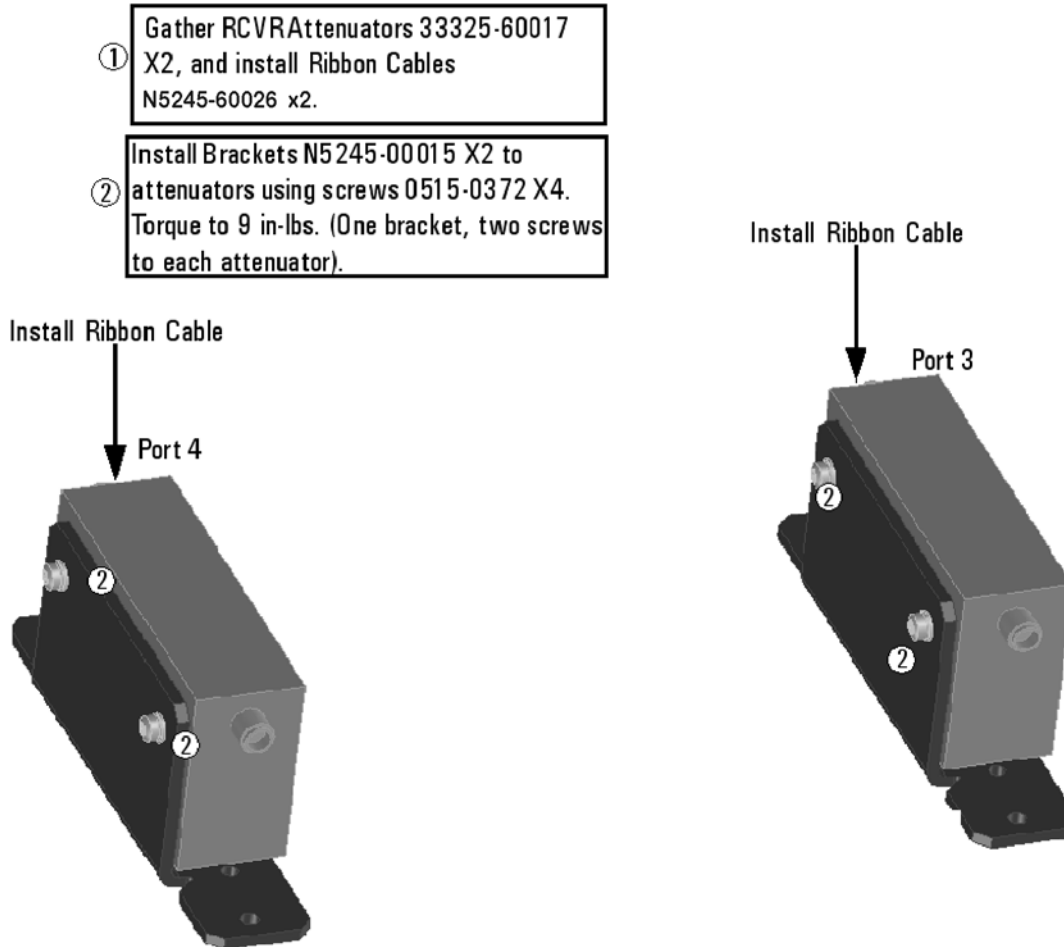

N5225\_124\_12

**Step 13. Install the A47 and A48 Receiver Attenuator Assemblies**

Follow the instructions shown in **Figure 9**. New parts are listed in **Table 1 on page 7** of this document.

**Figure 9 A47 and A48 Receiver Attenuator Assemblies Installation**

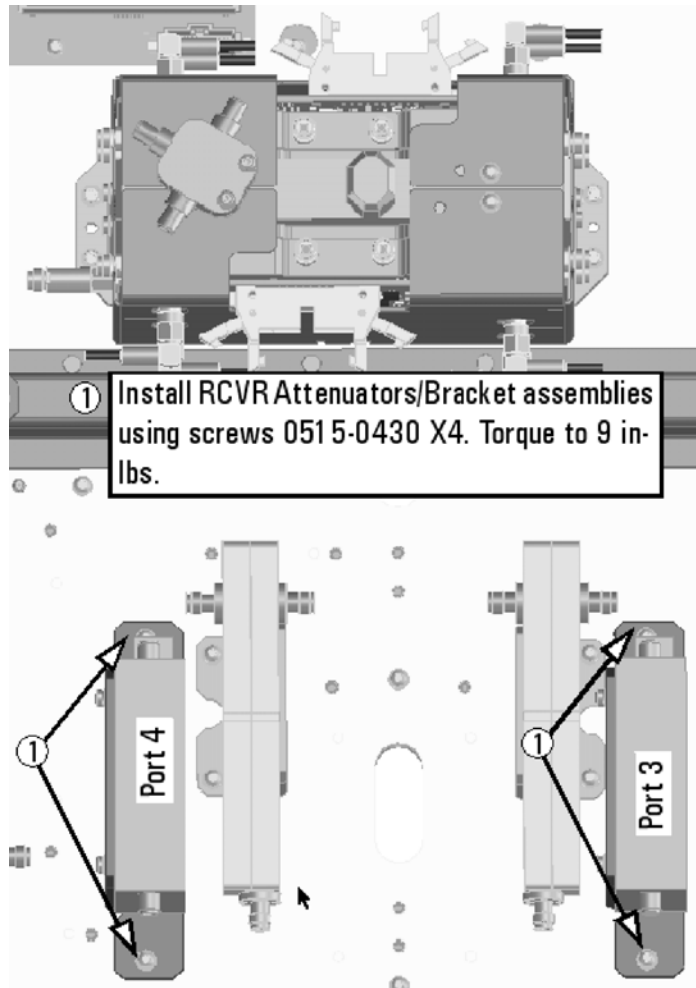

N5225\_124\_13



## Step 14. Assemble the A39 and A40 Source Attenuator Assemblies

Follow the instructions shown in [Figure 10](#). New parts are listed in [Table 1 on page 7](#) of this document.

**Figure 10** A39 and A40 Source Attenuators Assembly

- ① Gather SCRA attenuators 33325-60016 X2, and install Ribbon Cables N5245-60006 X2. (Source)
- ② Install Brackets N5245-00015 X2 to attenuators using screws 0515-0372 X4. Torque to 9 in-lbs. (One bracket, two screws to each attenuator).

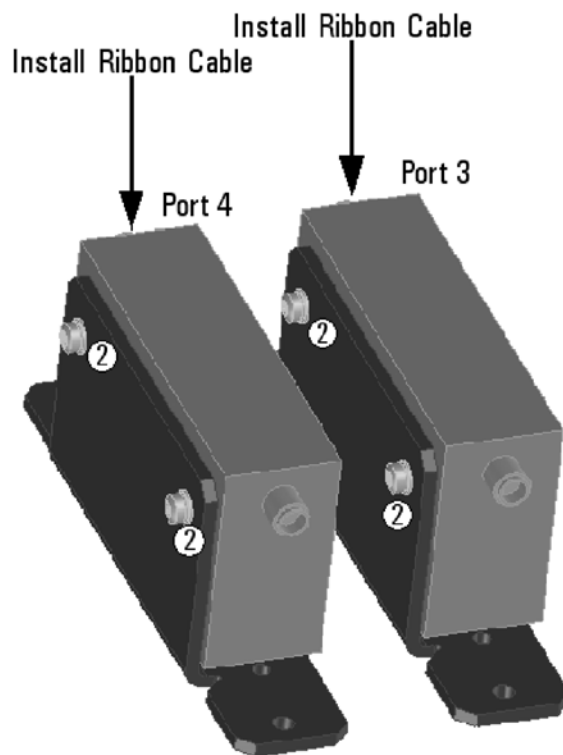

N5225\_124\_14

**Step 15. Install the A39 and A40 Source Attenuator Assemblies**

Follow the instructions shown in [Figure 11](#). New parts are listed in [Table 1 on page 7](#) of this document.

**Figure 11 A39 and A40 Source Attenuator Assemblies Installation**

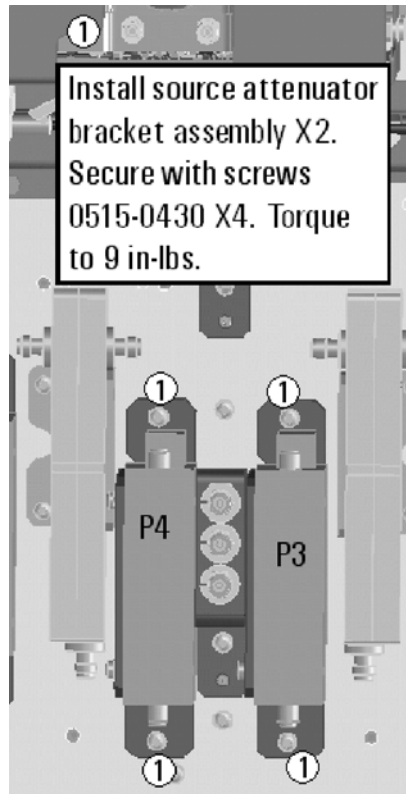

N5225\_124\_15

## Step 16. Install the Bias Tee Brackets

Follow the instruction in [Figure 12](#) to install the brackets for the A43 and A44 bias tees. New parts are listed in [Table 1](#) on [page 7](#) of this document.

**Figure 12** Bias Tee Brackets Installation

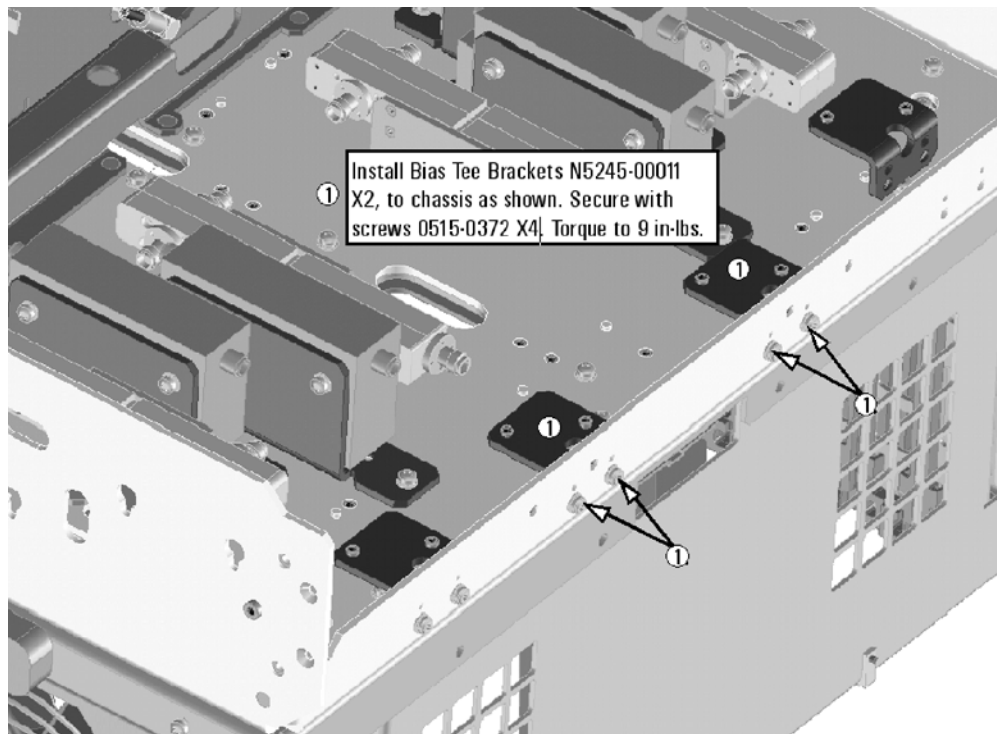

N5225\_124\_16

## Step 17. Install the A43 and A44 Bias Tees

Follow the instruction in [Figure 13](#) to install the A43 and A44 bias tees. New parts are listed in [Table 1 on page 7](#) of this document.

**Figure 13** A43 and A44 Bias Tees Installation

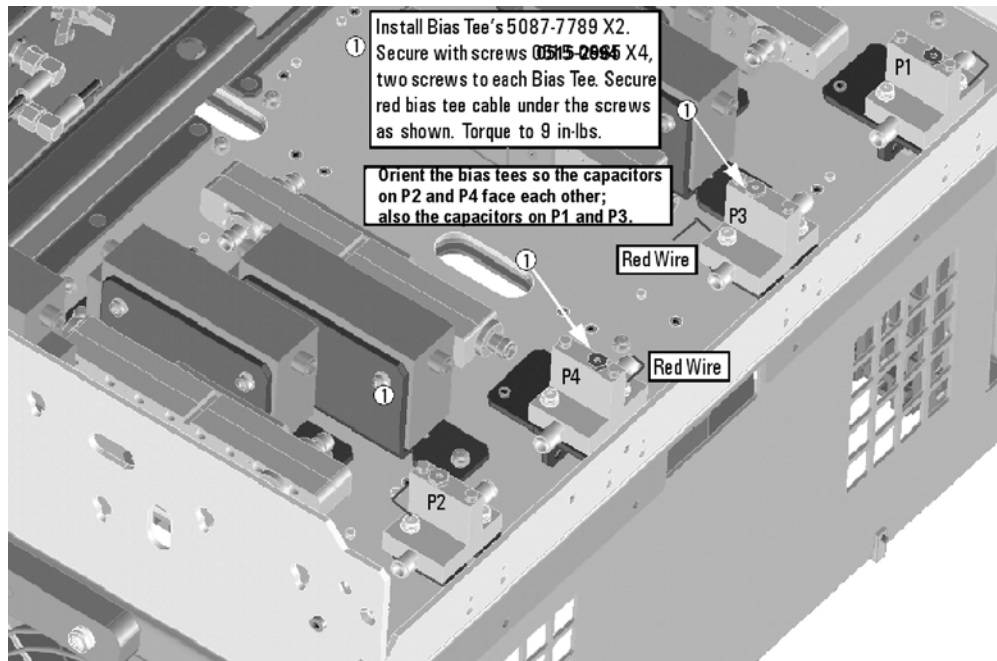

N5225\_124\_17

## Step 18. Assemble the A33 - A36 Test Port Coupler Assemblies

1. Remove the A33 test port 1 coupler and A36 test port 2 coupler from the PNA. For instructions, click the Chapter 7 bookmark, "Removing and Replacing the A33 - A36 Test Port Couplers" in the PDF Service Guide<sup>1</sup>.
2. Using pliers, remove the adhesive bumper on the A33 test port 1 coupler and on the A36 test port 2 coupler.
3. Follow the two instructions shown in [Figure 14](#). New parts are listed in [Table 1 on page 7](#) of this document.

**Figure 14** A33 - A36 Test Port Coupler Assembly

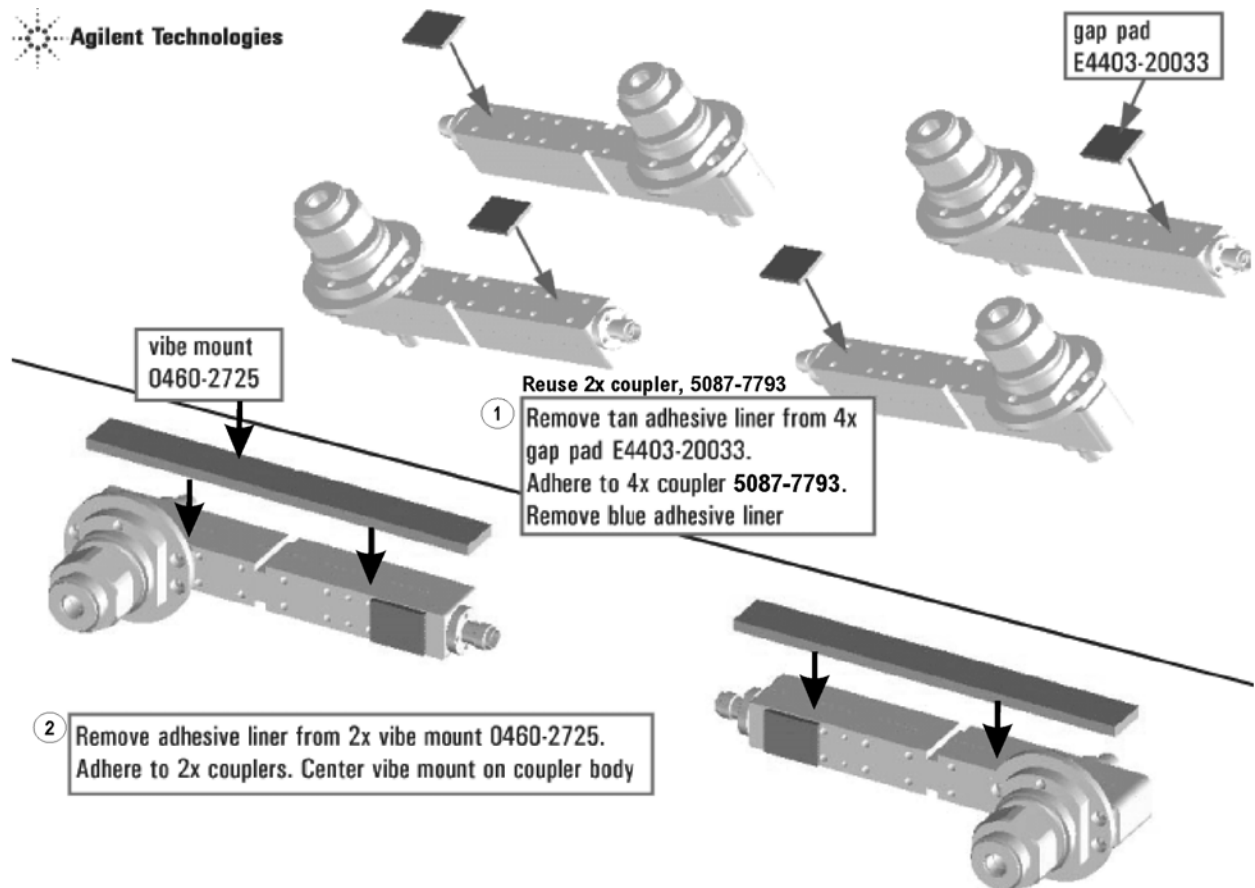

N5225\_124\_18

## Step 19. Install the LED Boards, Bulkhead Connectors, and Test Port Coupler Assemblies to the 4-Port Test Set Front Plate

1. Remove two screws from each LED board and remove the boards from the 2-port test set front plate of the PNA.
2. Remove the 2-port test set front plate from the test set deck. Keep the screws for reuse later.
3. Follow the two instructions shown in [Figure 15](#).

**Figure 15 LED Board Assemblies and Test Port Coupler Assemblies Installation**

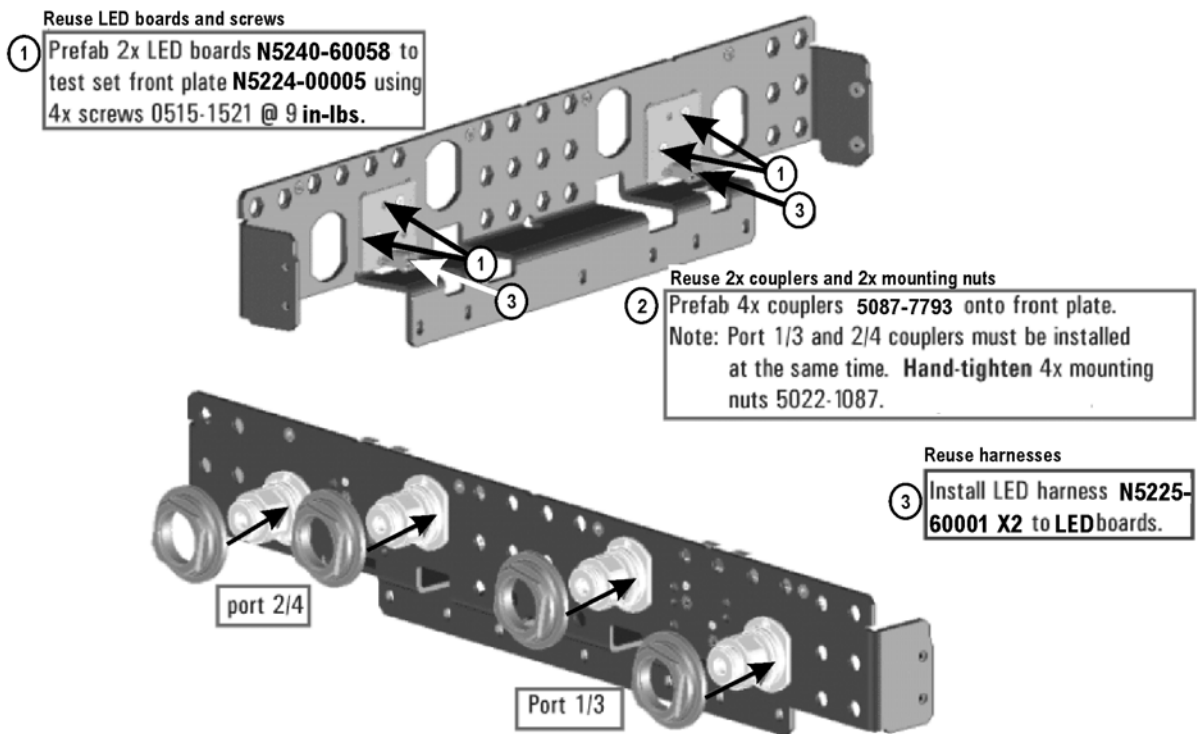

N5225\_124\_19

## Step 20. Install the 4-Port Coupler Plate Assembly to the Deck

Follow the four instructions shown in **Figure 16**.

**Figure 16 Coupler Plate Assembly Installation**

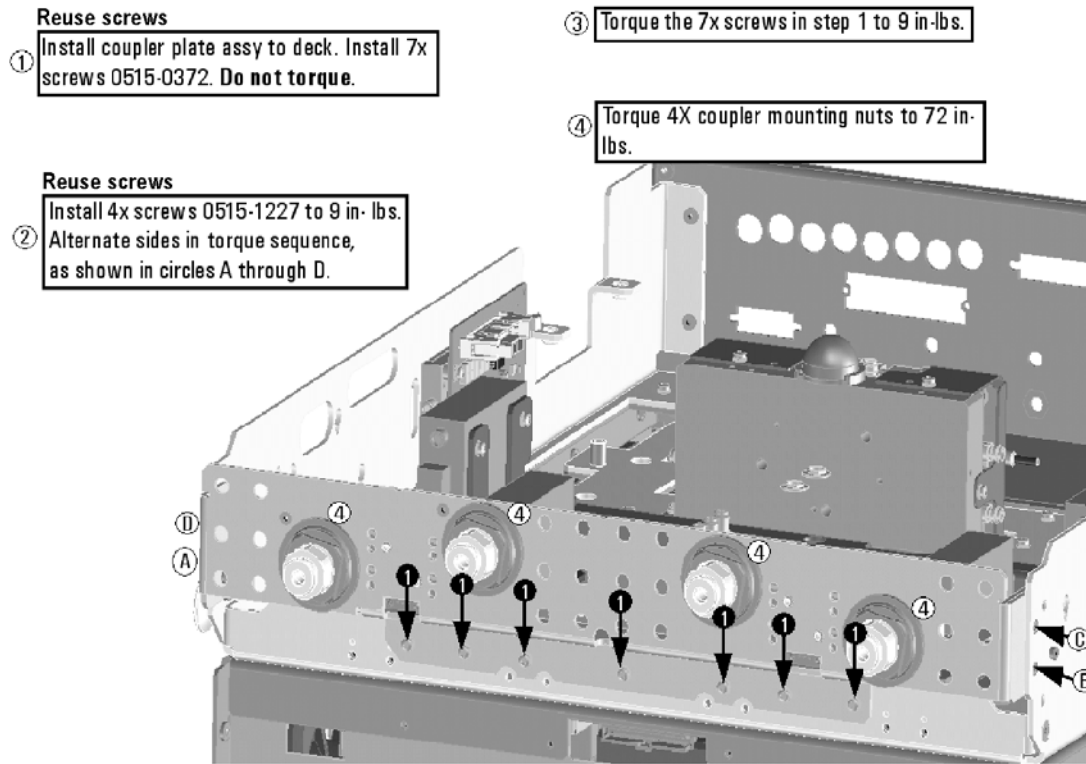

N5225\_124\_20

## Step 21. Assemble and Install the A12 and A13 40 GHz Doubler Assemblies

Follow the instructions shown in [Figure 17](#).

**Figure 17** A12 and A13 40 GHz Doubler Installation

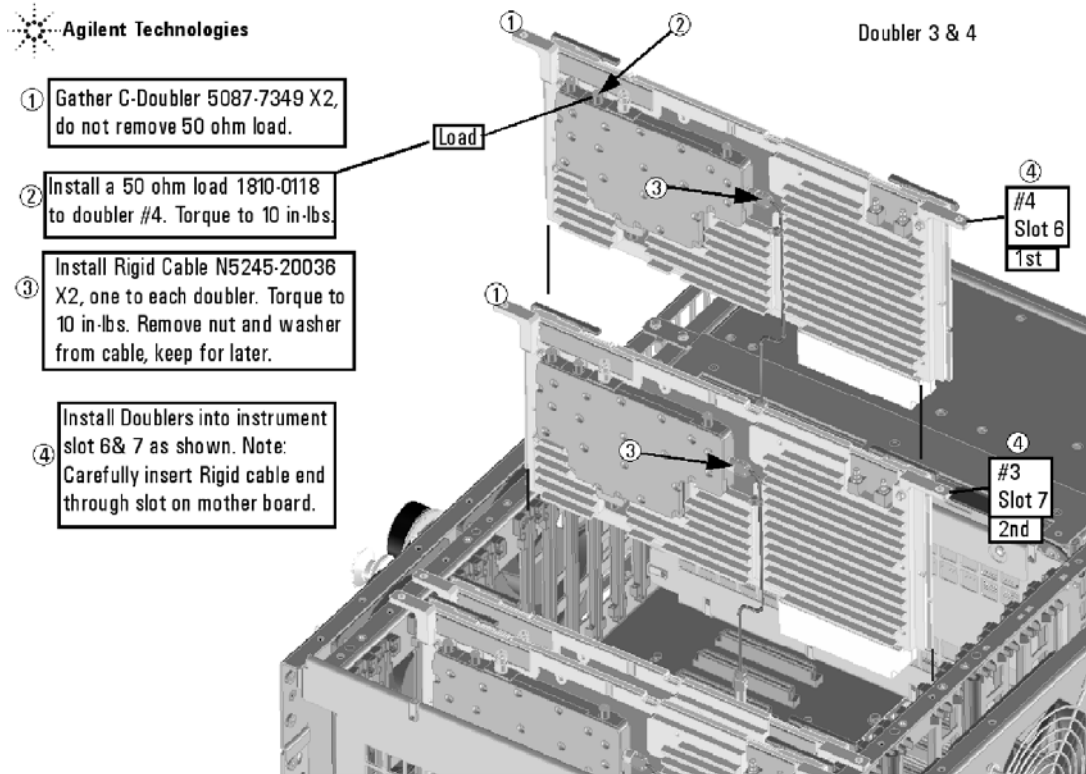

N5225\_124\_24



## Step 22. Install Bracket to A10 Source Assembly

Follow the two instructions shown in [Figure 18](#).

**Figure 18** A10 Source 2 Assembly Bracket Installation

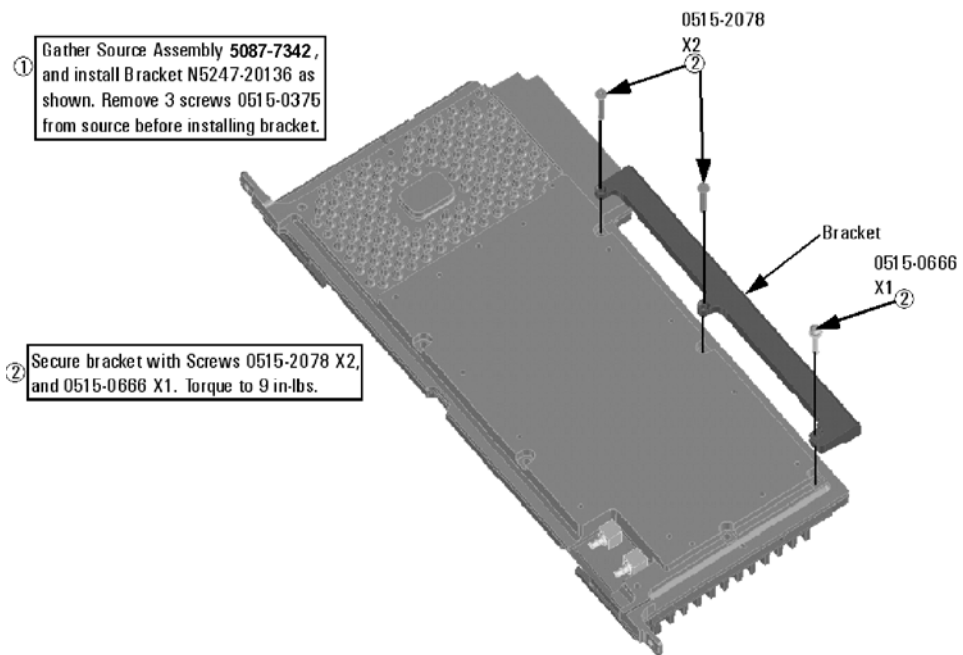

N5225\_124\_21

### Step 23. Assemble the A10 26.5 GHz Source 2 Assembly

Follow the four instructions shown in [Figure 19](#).

**Figure 19** A10 Source 2 Assembly

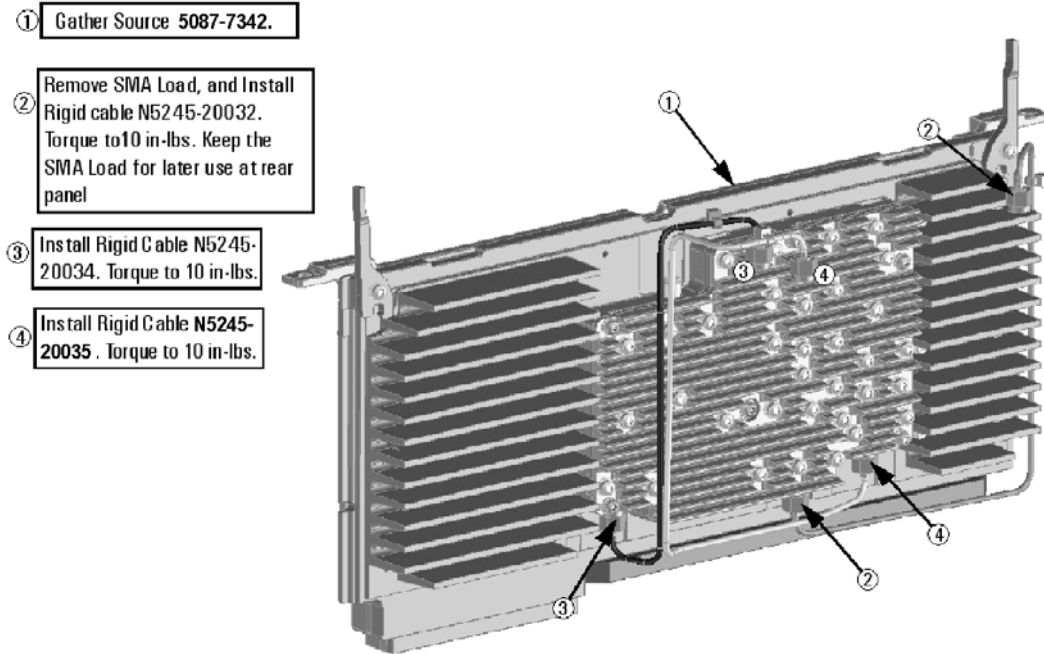

N5225\_124\_22

## Step 24. Install the A10 26.5 GHz Source 2 Assembly and Cables

Follow the four instructions shown in [Figure 20](#).

**Figure 20** A10 Source 2 Assembly Installation

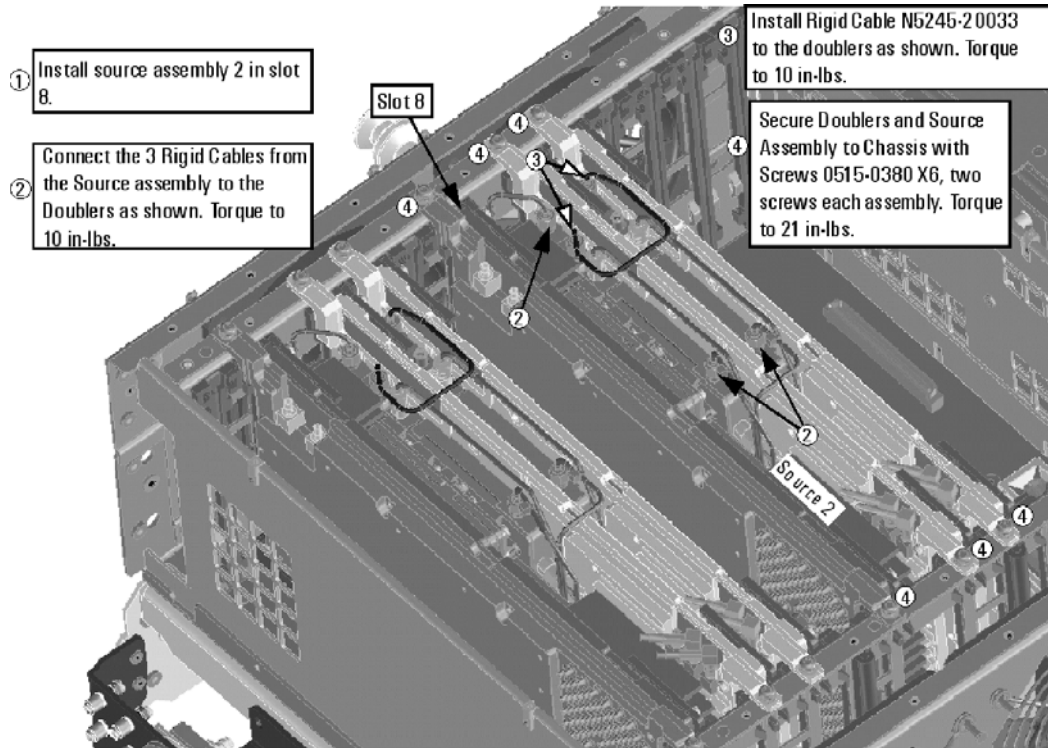

N5225\_124\_26

## Step 25. Install the A17 13.5 GHz (Source 2) Synthesizer Board and Cables

1. Install new gray cable W77 (N5242-60030) to connector J5 of the new A17 (source 2) synthesizer board (N5240-60074). The loose end of the cable will be connected on the A14 frequency reference board (J7) after the A17 board has been installed in the analyzer.
2. Install the A17 board into slot 2 in the motherboard. Secure the board into the chassis using two screws (0515-0380). To see an image showing the location of the A17 board in the motherboard, click the Chapter 6 bookmark "Top Assemblies, All Options" in the PDF Service Guide<sup>1</sup>.
3. Connect cable W2 (N5245-20100) between the A10 source 2 board and the A17 (source 2) synthesizer board, positioning the cable in the wire looms. Tighten the cable connectors to 10 in-lbs using a 5/16-in torque wrench.
4. Connect the loose end of new gray flex cable W77 (N5242-60030) on the A14 frequency reference board (J7). (The other end of this cable was previously connected to J5 of the source 2 synthesizer board.)

## Step 26. Install the Cable Bracket Mount

1. Follow the two instructions shown in [Figure 21](#). New parts are listed in [Table 1 on page 7](#) of this document.

**Figure 21 Cable Bracket Mount Installation**

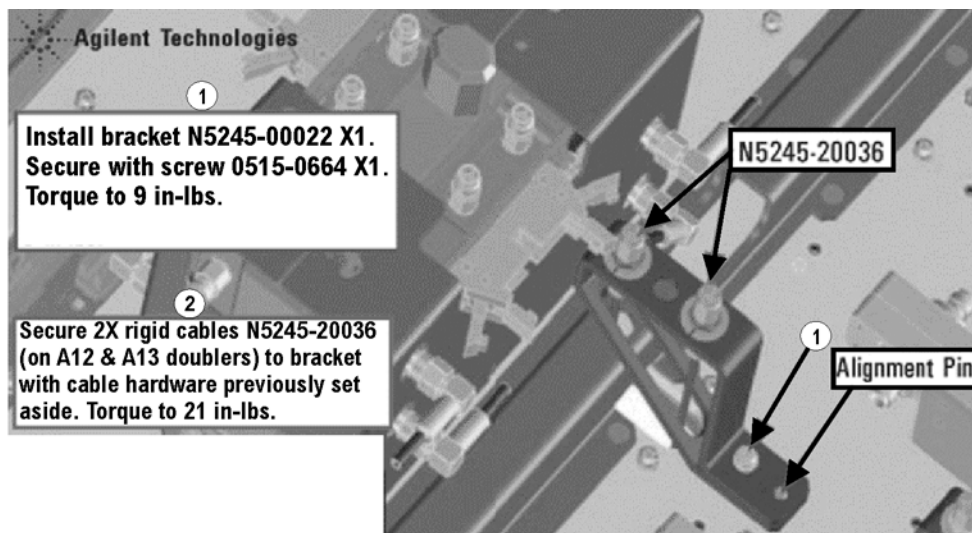

N5225\_124\_25

1. See ["Downloading the Online PNA Service Guide"](#) on page 5.

## Step 27. Install Some Bottom-Side (Test Set) Cables

---

**CAUTION** Use a 5/16-in torque wrench set to 10 in-lbs on all cable connections except the front and rear panel bulkhead connectors. On these, use a 9 mm nutsetter or open end torque wrench set to 21 in-lb.

---

---

**CAUTION** Be careful not to damage the center pins of the semirigid cables. Some flexing of the cables may be necessary but do not over-bend them.

---

---

**CAUTION** Follow instructions carefully when making cable connections, especially wire harness connections. Incorrect connections can destroy components, resulting in additional customer costs.

---

### Semirigid Cables Required for Upgrading to an Option 419 PNA

To see images showing the location of these cables, click the Chapter 6 bookmark “Bottom RF Cables, 4-Port, Option 419” in the PDF Service Guide<sup>1</sup>. New parts are listed in [Table 1 on page 7](#).

- W96 (N5245-20087) A45 port 2 bias tee to A36 port 2 coupler
- W92 (N5245-20088) A44 port 4 bias tee to A35 port 4 coupler
- W84 (N5245-20085) A33 port 1 coupler to A42 port 1 bias tee
- W88 (N5245-20086) A43 port 3 bias tee to A34 port 3 coupler
- W25 (N5245-20116) A30 port 3 receiver coupler to front-panel REF 3 SOURCE OUT

\* As shown in [Figure 22](#), install two clamps (part number 1400-1334) to secure W25 (N5245-20116).

---

1. See [“Downloading the Online PNA Service Guide” on page 5](#).

**Figure 22** Location of W25 Cable Securing Clamp

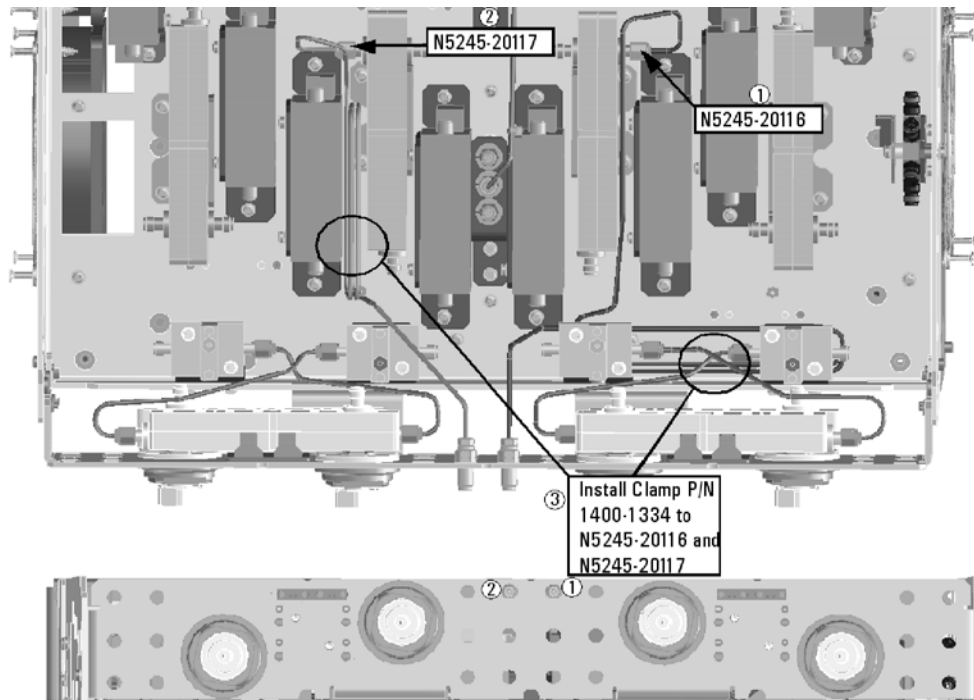

N5225\_124\_01

- W29 (N5245-20117) A31 port 4 receiver coupler to front-panel REF 4 SOURCE OUT
  - \* As shown in **Figure 22**, install clamp part number 1400-1334 to secure W29 (N5245-20117).
- W85 (N5245-20026) A30 port 3 receiver coupler to A39 port 3 source attenuator
- W89 (N5245-20026) A31 port 4 receiver coupler to A40 port 4 source attenuator
- W34 (N5245-20019) A36 port 2 coupler to front-panel Port 2 CPLR AR
- W47 (N5245-20115) REF 2 RCVR R2 IN to A27 mixer brick (R2)
- W30 (N5245-20018) A35 port 4 coupler to front-panel Port 4 CPLR ARM
- W101 (N5245-20074) Port 4 RCVR D IN to A48 port 4 receiver attenuator
- W90 (N5245-20028) A40 port 4 source attenuator to front-panel Port 4 SOURCE OUT
- W91 (N5245-20090) Port 4 CPLR THRU to A44 port 4 bias tee
- W45 (N5245-20021) REF 4 RCVR R4 IN to A69 3 dB pad on A28 mixer brick (R4)
- W99 (N5245-20073) Port 3 RCVR C IN to A47 port 3 receiver attenuator
- W87 (N5245-20089) Port 3 CPLR THRU to A43 port 3 bias tee
- W26 (N5245-20015) A34 port 3 coupler to front-panel Port 3 CPLR ARM
- W86 (N5245-20027) A39 port 3 source attenuator to front-panel Port 3 SOURCE OUT

- W44 (N5245-20020) REF 3 RCVR R3 IN to A28 mixer brick (R3)
- \* As shown in **Figure 23**, install two cable ties (part number 1400-1334) to secure W44.

**Figure 23 Location of Cable Ties to Secure W44 (N5245-20020)**

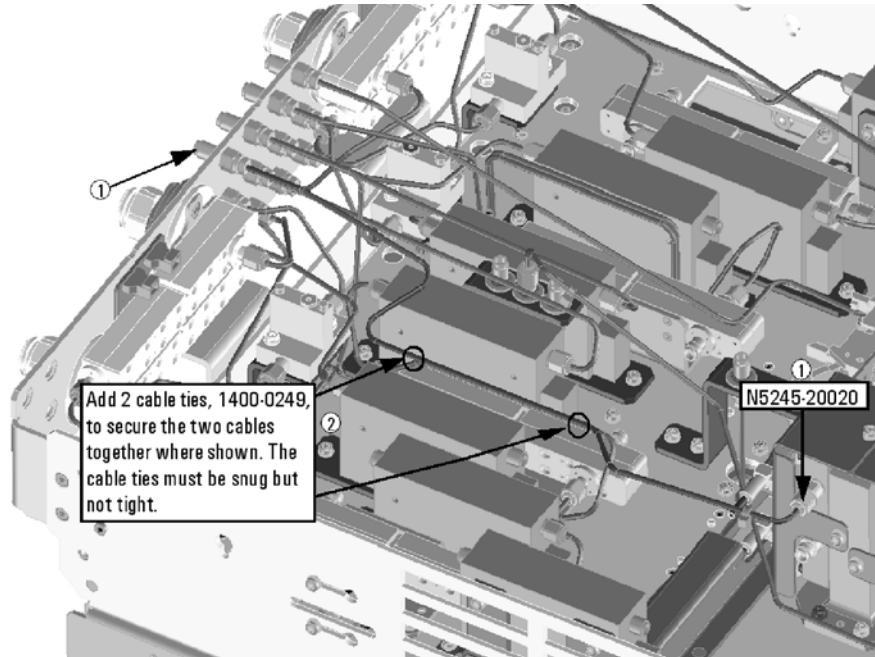

N5225\_124\_02

- W22 (N5245-20014) A33 port 1 coupler to front-panel Port 1 CPLR ARM
- W21 (N5245-20008) A29 port 1 receiver coupler to A37 reference mixer switch
- \* If the screws that attach the reference mixer switch to the test set deck were loosened, torque these screws now to 9 in-lbs.
- \* As shown in **Figure 24**, install a cable tie (part number 1400-1334) to secure W21.

**Figure 24** Location of Cable Tie to Secure W21 (N5245-20008)

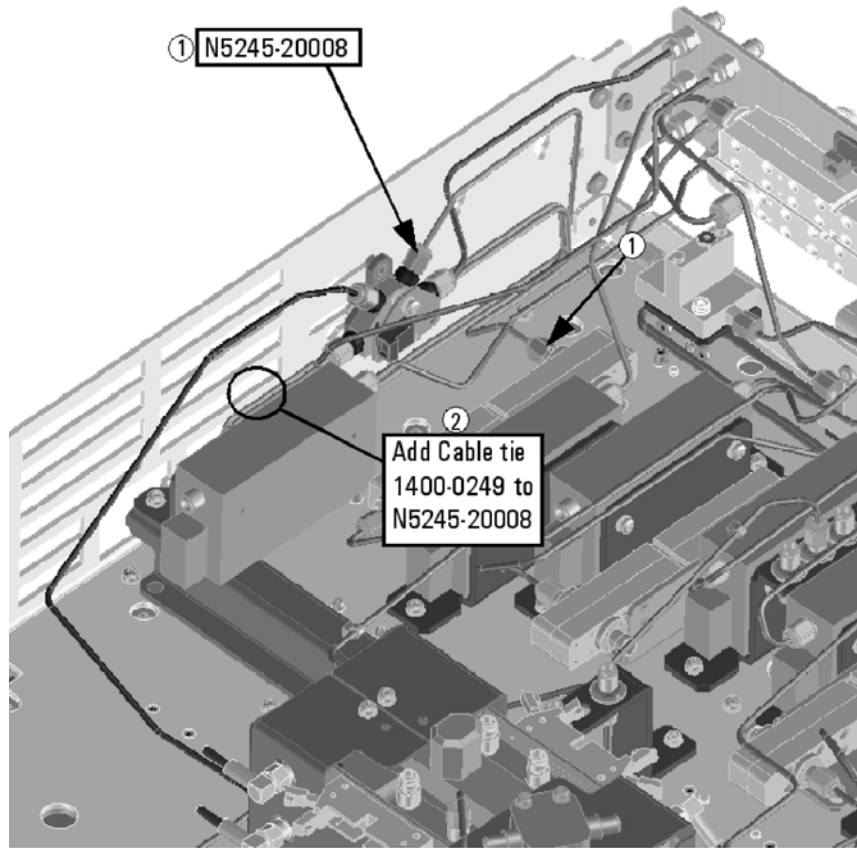

N5225\_124\_03

- W102 (N5245-20075) A48 port 4 receiver attenuator to A28 mixer brick (D)
- W100 (N5245-20066) A47 port 3 receiver attenuator to A28 mixer brick (C)
- W18 (reuse) (N5245-20049) A32 port 2 receiver coupler to W17
- W12 (reuse) (N5245-20050) A29 port 1 receiver coupler to W11
- W16 (N5245-20044) A31 port 4 receiver coupler to W15
- W14 (N5245-20043) A30 port 3 receiver coupler to W13
- W54 (N5245-20022) A26 splitter to A28 mixer brick
- W53 (N5245-20023) A26 splitter to A27 mixer brick
- W52 (N5245-20013) A25 HMA26.5 to A26 splitter

**NOTE:** Tighten both screws on the splitter to 9 in-lbs.



## Step 28. Secure the Front Panel Bulkhead Connectors

Follow the instruction shown in [Figure 25](#) in this document.

**Figure 25 Bulkhead Connections, Front Panel**

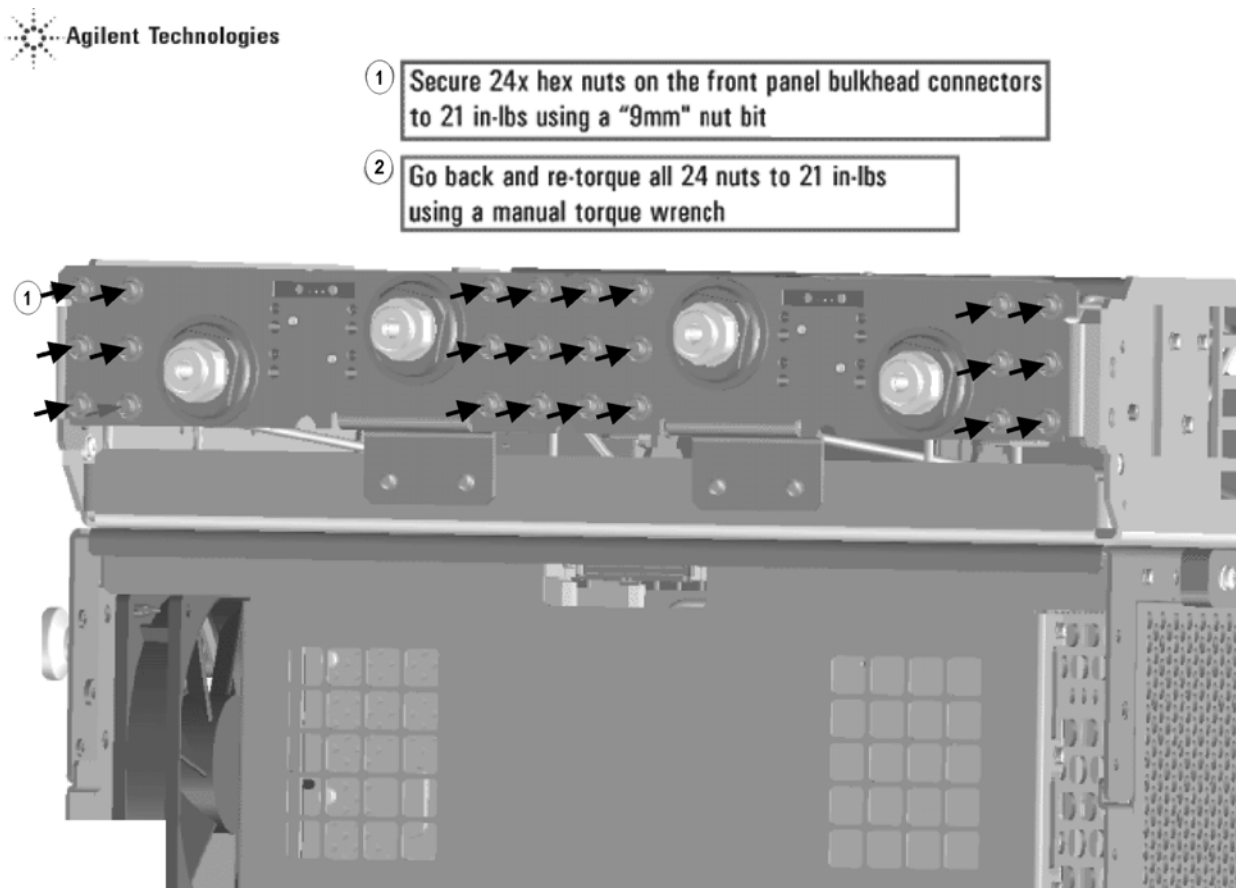

N5245\_016\_31

## Step 29. Install Cables on IF Multiplexer Board

Install the following gray flexible cables in the order listed. Mixer brick cables were connected to the mixer bricks earlier in this procedure, but the other ends of these cables still require a connection. To see images showing the location of these cables, click either of the Chapter 6 bookmarks "Bottom RF Cables, 4-Port, Option 419" in the PDF Service Guide<sup>1</sup>. New parts are listed in [Table 1 on page 7](#).

- W70 (N5242-60013) A24 IF multiplexer board P203 to A16 SPAM board J2
- W72 (N5242-60015) A24 IF multiplexer board P603 to A16 SPAM board J5
- W62 (N5242-60021) A27 mixer brick (R1) to A24 IF multiplexer (P411)
- W63 (N5242-60022) A27 mixer brick (R2) to A24 IF multiplexer (P412)

- W65 (N5242-60024) A28 mixer brick (D) to A24 IF multiplexer (P801)
- W66 (N5242-60019) A28 mixer brick (R4) to A24 IF multiplexer (P414)
- W67 (N5242-60020) A28 mixer brick (R3) to A24 IF multiplexer (P413)
- W68 (N5242-60023) A28 mixer brick (C) to A24 IF multiplexer (P601)

### Step 30. Reinstall the A23 Test Set Motherboard

For instructions on reinstalling the board, click the Chapter 7 bookmark “Removing and Replacing the A23 test set motherboard” in the PDF Service Guide<sup>1</sup>.

### Step 31. Install Cables on the A23 Test Set Motherboard

---

**CAUTION** Follow instructions carefully when making cable connections, especially wire harness connections. Incorrect connections can destroy components, resulting in additional customer costs.

---

If not already done in a previous step, install the following new ribbon cables in the order listed. To see an image showing their locations, click the Chapter 6 bookmark “Bottom Ribbon Cables and Wire Harnesses, 4-Port, Option 419” in the PDF Service Guide<sup>1</sup>. New parts are listed in [Table 1 on page 7](#).

- Ribbon cable (N5247-60015) from A28 mixer brick (2) J52 to A23 test set motherboard J552
- Ribbon cable (part of bias tee), A43 port 3 bias tee to A23 test set motherboard J543
- Ribbon cable (part of bias tee), A44 port 4 bias tee to A23 test set motherboard J544
- Ribbon cable (N5245-60026), A47 port 3 receiver attenuator to A23 test set motherboard J206
- Ribbon cable (N5245-60026), A48 port 4 receiver attenuator to A23 test set motherboard J207
- Ribbon cable (N5245-60006), A39 port 3 source attenuator to A23 test set motherboard J547
- Ribbon cable (N5245-60006), A40 port 4 source attenuator to A23 test set motherboard J548

### Step 32. Replace the Front Frame in the Front Panel Assembly

Before the front frame can be replaced, the items making up the back side of the front panel assembly must be removed. For instructions on removing these items, click the Chapter 7 bookmark “Removing and Replacing the A1-A3 and Other Front Panel Subassemblies” in the PDF Service Guide<sup>1</sup>. New parts are listed in [Table 1 on page 7](#).

1. In the section “Removing the A2 USB Board,” perform the only step.
2. In the section “Removing the A1 Front Panel Interface Board and Keypad Assembly,” perform steps 1 - 5.
3. In the section “Removing the Power Switch Board and Power Button Keypad,” perform only step 1.
4. Remove the braided gasket from the backside edges of the 2-port front frame and install it in the 4-port front frame.
5. Reassemble the front panel assembly with the new 4-port front frame (N5247-20141) by reversing the order

1. See [“Downloading the Online PNA Service Guide” on page 5](#).

of the instructions previously followed.

### **Step 33. Reinstall Front Panel Assembly**

1. For instructions on reinstalling the front panel assembly, click the Chapter 7 bookmark “Removing and Replacing the Front Panel Assembly” in the PDF Service Guide<sup>1</sup>.
2. Be sure to install the two new screws (0515-1946) in the front panel, next to test ports 3 and 4. Torque these screws to 9 in-lbs.

### **Step 34. Install the Overlays and Nameplate**

To see an image of the front panel overlay (N5227-80004), keypad overlay (N5242-80005), and power button overlay (N5242-80007), click the Chapter 6 bookmark “Front Panel Assembly, Front Side, All Options” in the PDF Service Guide<sup>1</sup>. New parts are listed in [Table 1 on page 7](#).

1. Remove the protective backing from the new front panel overlay (N5227-80004).
2. Loosely place the overlay in the recess on the lower front panel.
3. Placing two fingers at the middle, press the overlay firmly onto the frame while sliding your fingers in opposite directions towards the ends of the overlay. Repeat on all areas of the overlay.
4. Repeat steps 1-3 to install the keypad overlay (N5242-80005).
5. Repeat steps 1-3 to install the power button overlay (N5242-80007).
6. Repeat steps 1-3 to install the nameplate (N5224-80001 for model N5224A or N5225-80001 for model N5225A).

### **Step 35. Install the Front Panel Jumper Cables**

Install twelve W36 front panel jumper cables (N5245-20155) - use 6 new jumpers and reuse 6 old jumpers. To see an image of the front panel jumper cables, click the Chapter 7 bookmark “Removing and Replacing the Front Panel Assembly” in the PDF Service Guide<sup>1</sup>.

### **Step 36. Position the Cables and Wires to Prevent Pinching**

On the top side of the PNA, carefully position the grey flex cables so they can't be pinched between the covers and the rails.

On the bottom side of the PNA, carefully fold or push down the ribbon cables and wires so they can't be pinched between the hardware and the outer cover. Ribbon cables and wires must never be positioned on top of hardware.

### **Step 37. Reinstall the Inner Cover**

For instructions, click the Chapter 7 bookmark “Removing the Covers” in the PDF Service Guide<sup>1</sup>.

### **Step 38. Reinstall the Outer Cover**

For instructions, click the Chapter 7 bookmark “Removing the Covers” in the PDF Service Guide<sup>1</sup>.

## Step 39. Remove Option 219 License

### Procedure Requirements

- The analyzer must be powered up and operating to perform this procedure.
- The Network Analyzer program must be running.
- A keyboard and mouse must be connected to the network analyzer.

### Option 219 License Removal Procedure

1. To start the option enable utility, press UTILITY **System**, then **Service**, then **Option Enable**. An option enable dialog box will appear.
2. Click the arrow in the **Select Desired Option** box. A list of available options will appear.
3. In the **Select Desired Option** list, click **219**.
4. Click **Remove**.
5. Click **OK** to confirm that you want to remove the license for the selected option.
6. Click **Yes** in answer to the displayed question in the **Restart Analyzer?** box.

## Step 40. Enable Options P04 (400) and 419

### Procedure Requirements

- The analyzer must be powered up and operating to perform this procedure.
- The Network Analyzer program must be running.
- A keyboard and mouse must be connected to the network analyzer.

### Option Enable Procedure

1. To start the option enable utility, press UTILITY **System**, then **Service**, then **Option Enable**. An option enable dialog box will appear.
2. Click the arrow in the **Select Desired Option** box. A list of available options will appear.
3. In the **Select Desired Option** list, click **P04 - 4-Ports**.
4. Using the keyboard, enter the license key in the box provided. The license key is printed on the license message you received from Keysight. Enter this key *exactly* as it is printed on the message.
5. Click **Enable**.
6. Click **Yes** in answer to the displayed question in the **Restart Analyzer?** box.
7. Repeat steps 3-6 to enable Option 419, clicking **419 - Src/Rcvr Atten & Bias Ts 4-Port** in step 3.
8. When the installation is complete, click **Exit**.

### Option Verification Procedure

Once the analyzer has restarted and the Network Analyzer program is again running:

1. On the analyzer's **Help** menu, click **About Network Analyzer**.
2. Verify that "P04" and "419" are listed, but "219" is not listed after "Options:" in the display. Click **OK**.

---

**NOTE** If the options have not been enabled or if the option 219 license has not been removed, perform the prior steps again. If the options are still not correct, contact Keysight Technologies. Refer to [Getting Assistance from Keysight](#).

---

## **Step 41. Perform Post-Upgrade Adjustments and Calibration**

### **Adjustments**

The following adjustments must be made due to the hardware changes of the analyzer.

- default EE
- source adjustment
- receiver adjustment
- receiver characterization

These adjustments are described in the PNA Service Guide and in the PNA on-line HELP. A list of equipment required to perform these adjustments is also found in the service guide.

After the specified adjustments have been performed, the analyzer should operate and phase lock over its entire frequency range.

### **Operator's Check**

Perform the Operator's Check to check the basic functionality of the analyzer. For instructions, click the Chapter 3 bookmark "Tests and Adjustments" in the PDF Service Guide<sup>1</sup>.

If you experience difficulty with the basic functioning of the analyzer, contact Keysight. Refer to ["Contacting Keysight" on page 3](#).

### **Calibration**

Although the analyzer functions, its performance relative to its specifications has not been verified. It is recommended that a full instrument calibration be performed using the analyzer's internal performance test software. To view information on the performance test software, click the Chapter 3 bookmark "Tests and Adjustments" in the PDF Service Guide<sup>1</sup>.

## **Step 42. Prepare the PNA for the User**

1. If necessary, reinstall front jumper cables.
2. Install the cable guards, pushing them over the front jumper cables until the cushioning material touches the front panel of the PNA.
3. Install the dust caps on the test ports.
4. Clean the analyzer, as needed, using a damp cloth.

---

1. See ["Downloading the Online PNA Service Guide" on page 5](#).

This information is subject to change without notice.

© Keysight Technologies 2011 - 2014

December 1, 2014



N5225-90124  
[www.keysight.com](http://www.keysight.com)