

Keysight Extended Power Range and Bias Tees Upgrade Kit

To Upgrade PNA N5227A Option 401 to Option 419
Upgrade Kit Order Number: N5227AU-419
Keysight Kit Number: N5227-60106

NOTICE: This document contains references to Agilent Technologies. Agilent's former Test and Measurement business has become Keysight Technologies. For more information, go to www.keysight.com.



WARRANTY STATEMENT

THE MATERIAL CONTAINED IN THIS DOCUMENT IS PROVIDED "AS IS," AND IS SUBJECT TO BEING CHANGED, WITHOUT NOTICE, IN FUTURE EDITIONS. FURTHER, TO THE MAXIMUM EXTENT PERMITTED BY APPLICABLE LAW, KEYSIGHT DISCLAIMS ALL WARRANTIES, EITHER EXPRESS OR IMPLIED WITH REGARD TO THIS MANUAL AND ANY INFORMATION CONTAINED HEREIN, INCLUDING BUT NOT LIMITED TO THE IMPLIED WARRANTIES OF MERCHANTABILITY AND FITNESS FOR A PARTICULAR PURPOSE. KEYSIGHT SHALL NOT BE LIABLE FOR ERRORS OR FOR INCIDENTAL OR CONSEQUENTIAL DAMAGES IN CONNECTION WITH THE FURNISHING, USE, OR PERFORMANCE OF THIS DOCUMENT OR ANY INFORMATION CONTAINED HEREIN. SHOULD KEYSIGHT AND THE USER HAVE A SEPARATE WRITTEN AGREEMENT WITH WARRANTY TERMS COVERING THE MATERIAL IN THIS DOCUMENT THAT CONFLICT WITH THESE TERMS, THE WARRANTY TERMS IN THE SEPARATE AGREEMENT WILL CONTROL.

DFARS/Restricted Rights Notice

If software is for use in the performance of a U.S. Government prime contract or subcontract, Software is delivered and licensed as "Commercial computer software" as defined in DFAR 252.227-7014 (June 1995), or as a "commercial item" as defined in FAR 2.101(a) or as "Restricted computer software" as defined in FAR 52.227-19 (June 1987) or any equivalent agency regulation or contract clause. Use, duplication or disclosure of Software is subject to Keysight Technologies' standard commercial license terms, and non-DOD Departments and Agencies of the U.S. Government will receive no greater than Restricted Rights as defined in FAR 52.227-19(c)(1-2) (June 1987). U.S. Government users will receive no greater than Limited Rights as defined in FAR 52.227-14 (June 1987) or DFAR 252.227-7015 (b)(2) (November 1995), as applicable in any technical data.

Safety Notes

The following safety notes are used throughout this document. Familiarize yourself with each of these notes and its meaning before performing any of the procedures in this document.

WARNING **Warning denotes a hazard. It calls attention to a procedure which, if not correctly performed or adhered to, could result in injury or loss of life. Do not proceed beyond a warning note until the indicated conditions are fully understood and met.**

CAUTION Caution denotes a hazard. It calls attention to a procedure that, if not correctly performed or adhered to, could result in damage to or destruction of the instrument. Do not proceed beyond a caution note until the indicated conditions are fully understood and met.

Description of the Upgrade

This upgrade converts your standard 4-port configurable test set analyzer (N5227A Option 401) to an extended power range analyzer with bias tees by adding:

- a 50-dB source attenuator and a bias tee in each source port channel
- a 50-dB receiver attenuator in each receiver channel

After installation of this upgrade, your analyzer will be an N5227A Option 419.

Getting Assistance from Keysight

By internet, phone, or fax, get assistance with all your test and measurement needs.

Contacting Keysight

Assistance with test and measurements needs and information on finding a local Keysight office are available on the Web at:

<http://www.keysight.com/find/assist>

If you do not have access to the Internet, please contact your Keysight field engineer.

NOTE In any correspondence or telephone conversation, refer to the Keysight product by its model number and full serial number. With this information, the Keysight representative can determine whether your product is still within its warranty period.

Getting Prepared

CAUTION The PNA contains extremely sensitive components that can be ruined if mishandled. Follow instructions carefully when making cable connections, especially wire harness connections.

The person performing the work accepts responsibility for the full cost of the repair or replacement of damaged components.

To successfully install this upgrade kit, you will need the following:

- A license key - refer to “[License Key Redemption](#)” below.
- A PDF copy or a paper copy of the PNA Service Guide - refer to “[Downloading the Online PNA Service Guide](#)” below.
- An ESD-safe work area - refer to “[Protecting Your Workspace from Electrostatic Discharge](#)” below.
- Correct tools - refer to “[Tools Required for the Installation](#)” on page 6.
- Enough time - refer to “[About Installing the Upgrade](#)” on page 6.
- Test equipment for the post-upgrade adjustments and full instrument calibration. To view the equipment list, click the Chapter 3 bookmark “Tests and Adjustments” in the PDF Service Guide¹.

License Key Redemption

NOTE The enclosed Option Entitlement Certificate is a receipt, verifying that you have purchased a licensed option for the PNA of your choice. You must now use a Keysight Web page to request a license key for the instrument that will receive the option.

To enable the option product, you must request a license key from: <http://www.keysight.com/find/softwarelicense>. To complete the request, you will need to gather the following information:

- From the certificate
 - Order number
 - Certificate number
- From your instrument
 - Model number
 - Serial number
 - Host ID

The instrument information is available on the network analyzer – on the analyzer’s **Help** menu, click **About Network Analyzer**.

If you provide an email address, Keysight will promptly email your license key. Otherwise, you will receive your license key via postal mail.

1. See “[Downloading the Online PNA Service Guide](#)” on page 5.

Downloading the Online PNA Service Guide

To view the online Service Guide for your PNA model number, use the following steps:

1. Go to www.keysight.com.
2. In the Search box, enter the model number of the analyzer (Ex: N5242A) and click **Search**.
3. Click **Technical Support > Manuals**.
4. Click **Service Manual**.
5. Click the service guide title to download the PDF file.
6. When the PDF of the Service Guide is displayed, scroll through the Contents section bookmarks to locate the information needed.

Protecting Your Workspace from Electrostatic Discharge

For information, click on the Chapter 1 bookmark, “Electrostatic Discharge Protection” in the PDF Service Guide¹.

ESD Equipment Required for the Installation

Description	Keysight Part Number
ESD grounding wrist strap	9300-1367
5-ft grounding cord for wrist strap	9300-0980
2 x 4 ft conductive table mat and 15-ft grounding wire	9300-0797
ESD heel strap (for use with conductive floors)	9300-1308

1. See [“Downloading the Online PNA Service Guide”](#) on page 5.

Tools Required for the Installation

Description	Qty	Part Number
T-10 TORX driver - set to 9 in-lbs (1.02 N.m)	1	N/A
T-20 TORX driver - set to 21 in-lbs (2.38 N.m)	1	N/A
5/16-in (8 mm) nutsetter or open end torque wrench - set to 10 in-lbs (1.13 N.m)	1	N/A
9 mm nutsetter or open end torque wrench - set to 21 in-lbs (2.38 N.m)	1	N/A

CAUTION Use a 5/16-in torque wrench set to 10 in-lbs on all cable connections except the front and rear panel bulkhead connectors. On these, use a 9 mm nutsetter or open end torque wrench set to 21 in-lb.

About Installing the Upgrade

Products affected	N5227A Option 401
Installation to be performed by	Keysight service center or personnel qualified by Keysight
Estimated installation time	3 hours
Estimated adjustment time	0.5 hour
Estimated full instrument calibration time	4.5 hours

Items Included in the Upgrade Kit¹

Check the contents of your kit against the following list. If any part is missing or damaged, contact Keysight Technologies. Refer to [“Getting Assistance from Keysight” on page 3](#).

Table 1 Contents of Upgrade Kit N5227-60106

Ref Desig.	Description	Qty	Part Number
--	Installation note (this document)	1	N5227-90106
A38– A41	0–50 dB source step attenuator	4	84905-60002
A42– A45	Bias tee	4	5087-7732
A46– A49	0-50 dB receiver step attenuator	4	84905-60002
--	Attenuator bracket	4	N5247-00005
--	Bias tee bracket	2	N5247-20129
--	Machine screw, M3 x 8, pan head (16 to attach attenuators to brackets; 16 to attach attenuator assemblies to deck; 2 to attach port 2 reference coupler assembly to port 2 attenuators assembly; 3 to attach port 3 reference coupler assembly to port 3 attenuators assembly; 3 to attach port 4 reference coupler assembly to port 4 attenuators assembly; 3 to attach port 1 reference coupler assembly to port 1 attenuators assembly; 4 to attach bias tee assemblies to deck; 8 to secure center braces)	60	0515-0372
--	Machine screw, M3 x 6, flat head (to secure bias tees to brackets)	10	0515-1227
--	Machine screw, M3 x 10, pan head (to secure side braces)	5	0515-0374
--	Machine screw, M4 x 10, pan head (to secure center braces)	3	0515-0380
--	Cable clamp (3 to secure W146 (N5247-20058); 1 to secure W145 (N5247-20066); 1 to secure W41 (N5247-20069); 1 to secure W37 (N5247-20070).	11	1400-1334
--	Cable tie wrap, 2 to secure W120 (N5247-20064); 2 to secure W144 (N5247-20071).	8	1400-0249
-	Brace (center), bottom side of PNA	2	N5247-20134
-	Brace (center), bottom side of PNA	1	N5247-20133
-	Brace (side), bottom side of PNA	2	N5247-20132
-	2.4 mm dust cap for A28 mixer brick	1	N5247-20138
W27	RF cable, A60 port 1 70 GHz doubler to A29 port 1 reference coupler	1	N5247-20044
W28	RF cable, A61 port 3 70 GHz doubler to A30 port 3 reference coupler	1	N5247-20043
W29	RF cable, A62 port 4 70 GHz doubler to A31 port 4 reference coupler	1	N5247-20044
W30	RF cable, A63 port 2 70 GHz doubler to A32 port 2 reference coupler	1	N5247-20043

1. In addition to the upgrade kit, the shipment includes an Option Entitlement Certificate. Refer to [“License Key Redemption” on page 4](#) for important information about this certificate.

Table 1 Contents of Upgrade Kit N5227-60106

Ref Desig.	Description	Qty	Part Number
W37	RF cable, A30 port 3 reference coupler to front-panel REF 3 SOURCE OUT	1	N5247-20070
W41	RF cable, A31 port 4 reference coupler to front-panel REF 4 SOURCE OUT	1	N5247-20069
W101	RF cable, A29 port 1 reference coupler to A38 port 1 source attenuator	1	N5247-20083
W102	RF cable, A38 port 1 source attenuator to front-panel port 1 SOURCE OUT	1	N5247-20014
W103	RF cable, Front-panel port 1 CPLR THRU to A42 port 1 bias tee	1	N5247-20010
W104	RF cable, A33 port 1 coupler to A42 port 1 bias tee	1	N5247-20022
W105	RF cable, A30 port 3 receiver coupler to A39 port 3 source attenuator	1	N5247-20083
W106	RF cable, A39 port 3 source attenuator to front-panel port 3 SOURCE OUT	1	N5247-20009
W107	RF cable, Port 3 CPLR THRU to A43 port 3 bias tee	1	N5247-20081
W108	RF cable, A43 port 3 bias tee to A34 port 3 coupler	1	N5247-20028
W109	RF cable, A31 port 4 reference coupler to A40 port 4 source attenuator	1	N5247-20083
W110	RF cable, A40 port 4 source attenuator to front-panel port 4 SOURCE OUT	1	N5247-20025
W111	RF cable, Port 4 CPLR THRU to A44 port 4 bias tee	1	N5247-20021
W112	RF cable, A44 port 4 bias tee to A35 port 4 coupler	1	N5247-20029
W113	RF cable, A32 port 2 reference coupler to A41 port 2 source attenuator	1	N5247-20083
W114	RF cable, A41 port 2 source attenuator to front-panel port 2 SOURCE OUT	1	N5247-20034
W115	RF cable, Port 2 CPLR THRU to A45 port 2 bias tee	1	N5247-20027
W116	RF cable, A45 port 2 bias tee to A36 port 2 coupler	1	N5247-20080
W117	RF cable, Front-panel port 1 RCVR A IN to A46 port 1 receiver attenuator	1	N5247-20013
W118	RF cable, A46 port 1 receiver attenuator to A27 mixer brick (A)	1	N5247-20047
W119	RF cable, Port 3 RCVR C IN to A47 port 3 receiver attenuator	1	N5247-20008
W120	RF cable, A47 port 3 receiver attenuator to A28 mixer brick (C)	1	N5247-20064
W121	RF cable, Port 4 RCVR D IN to A48 port 4 receiver attenuator	1	N5247-20024
W122	RF cable, A48 port 4 receiver attenuator to A28 mixer brick (D)	1	N5247-20065
W123	RF cable, Port 2 RCVR B IN to A49 port 2 receiver attenuator	1	N5247-20020
W124	RF cable, A49 port 2 receiver attenuator to A27 mixer brick (B)	1	N5247-20046
W144	RF cable, A29 port 1 reference coupler to A37 reference mixer switch	1	N5247-20071
W145	RF cable, REF 2 RCVR R2 IN to A27 mixer brick (R2)	1	N5247-20066
W146	RF cable, A32 port 2 ref coupler to front-panel REF 2 SOURCE OUT	1	N5247-20058
--	Ribbon cable, A23 test set motherboard J205 to A46 port 1 receiver attenuator	4	N5247-60020
--	Ribbon cable, A23 test set motherboard J206 to A47 port 3 receiver attenuator		
--	Ribbon cable, A23 test set motherboard J207 to A48 port 4 receiver attenuator		
--	Ribbon cable, A23 test set motherboard J208 to A49 port 2 receiver attenuator		

Table 1 Contents of Upgrade Kit N5227-60106

Ref Desig.	Description	Qty	Part Number
--	Ribbon cable, A23 test set motherboard J549 to A38 test port 1 source attenuator	4	N5245-60006
--	Ribbon cable, A23 test set motherboard J547 to A39 test port 3 source attenuator		
--	Ribbon cable, A23 test set motherboard J548 to A40 test port 4 source attenuator		
--	Ribbon cable, A23 test set motherboard J546 to A41 test port 2 source attenuator		
--	Ribbon cable, A23 test set motherboard J541 to A42 port 1 bias tee	4	N5247-60021
--	Ribbon cable, A23 test set motherboard J543 to A43 port 3 bias tee		
--	Ribbon cable, A23 test set motherboard J544 to A44 port 4 bias tee		
--	Ribbon cable, A23 test set motherboard J542 to A45 port 2 bias tee		

NOTE Extra quantities of items such as protective plastic caps, screws, cable ties, and cable clamps may be included in this upgrade kit. It is normal for some of these items to remain unused after the upgrade is completed.

Installation Procedure for the Upgrade

The network analyzer must be in proper working condition prior to installing this option. Any necessary repairs must be made before proceeding with this installation.

WARNING **This installation requires the removal of the analyzer's protective outer covers. The analyzer must be powered down and disconnected from the mains supply before performing this procedure.**

Overview of the Installation Procedure

- Step 1. Obtain a Keyword and Verify the Information.
- Step 2. Remove the Outer Cover.
- Step 3. Remove the Inner Cover.
- Step 4. Remove the Front Panel Assembly.
- Step 5. Remove Some Bottom-Side (Test Set) Cables.
- Step 6. Remove Port 1 and Port 2 Reference Coupler Assemblies from the Test Set Deck.
- Step 7. Swap Brackets on the Port 1 and Port 2 Reference Coupler Assemblies.
- Step 8. Remove Port 3 and Port 4 Reference Coupler Assemblies from the Test Set Deck.
- Step 9. Swap Brackets on the Port 3 and Port 4 Reference Coupler Assemblies.
- Step 10. Assemble the Port 2 and Port 3 Step Attenuators.
- Step 11. Install the Port 2 and Port 3 Step Attenuators.
- Step 12. Assemble the Port 1 and Port 4 Step Attenuators.
- Step 13. Install the Port 1 and Port 4 Step Attenuators.
- Step 14. Reinstall the Port 1, Port 2, Port 3 and Port 4 Reference Coupler Assemblies.
- Step 15. Assemble the Bias Tees.
- Step 16. Install the Bias Tee Assemblies.
- Step 17. Install Some Bottom-Side (Test Set) Cables.
- Step 18. Install the Braces.
- Step 19. Reinstall Front Panel Assembly.
- Step 20. Position the Cables and Wires to Prevent Pinching.
- Step 21. Reinstall the Inner Cover.
- Step 22. Reinstall the Outer Cover.
- Step 23. Enable Option 419.
- Step 24. Perform Post-Upgrade Adjustments and Calibration.
- Step 25. Prepare the PNA for the User.

Step 1. Obtain a Keyword and Verify the Information

Follow the instructions on the Option Entitlement Certificate supplied to obtain a license key for installation of this upgrade. Refer to [“License Key Redemption” on page 4](#).

Verify that the model number, serial number, and option number information on the license key match those of the instrument on which this upgrade will be installed.

If the model number, serial number, or option number do not match those on your license key, you will not be able to install the option. If this is the case, contact Keysight for assistance before beginning the installation of this upgrade. Refer to [“Contacting Keysight” on page 3](#).

Once the license key has been received and the information verified, you can proceed with the installation at step 2.

Step 2. Remove the Outer Cover

For instructions, click the Chapter 7 bookmark “Removing the Covers” in the PDF Service Guide¹.

Step 3. Remove the Inner Cover

For instructions, click the Chapter 7 bookmark “Removing the Covers” in the PDF Service Guide¹.

Step 4. Remove the Front Panel Assembly

For instructions, click the Chapter 7 bookmark “Removing and Replacing the Front Panel Assembly” in the PDF Service Guide¹.

1. See [“Downloading the Online PNA Service Guide” on page 5](#).

Step 5. Remove Some Bottom-Side (Test Set) Cables

CAUTION Be careful not to damage the center pins of the semirigid cables. Some flexing of the cables may be necessary but do not over-bend them.

NOTE When removing a cable, also remove the plastic cable clamp, if present. It is normal for some of the cable clamp's adhesive to remain.

1. Place the analyzer bottom-side up on a flat surface.
2. Remove the cables in the following two lists in the order shown. To see an image showing the location of these cables, click the Chapter 6 bookmark "Bottom RF Cables, Standard 4-Port Configuration, Option 401" in the PDF Service Guide¹.

These cables may be discarded - they will **not** be reinstalled.

- W27 (N5247-20074) A60 port 1 70 GHz doubler to A29 port 1 reference coupler
- W30 (N5247-20052) A63 port 2 70 GHz doubler to A32 port 2 reference coupler
- W28 (N5247-20052) A61 port 3 70 GHz doubler to A30 port 3 reference coupler
- W29 (N5247-20074) A62 port 4 70 GHz doubler to A31 port 4 reference coupler
- W31 (N5247-20037) A29 port 1 ref coupler to front-panel port 1 SOURCE OUT
- W47 (N5247-20053) Port 1 RCVR A IN to A27 mixer brick (A)
- W33 (N5247-20078) A29 port 1 reference coupler to A37 reference mixer switch
- W36 (N5247-20006) Port 3 CPLR THRU to A34 port 3 coupler
- W32 (N5247-20016) Port 1 CPLR THRU to A33 port 1 coupler
- W35 (N5247-20023) A30 port 3 ref coupler to front-panel port 3 SOURCE OUT
- W48 (N5247-20063) Port 3 RCVR C IN to A28 mixer brick (C)
- W37 (N5247-20077) A30 port 3 ref coupler to front-panel REF 3 SOURCE OUT
- W41 (N5247-20075) A31 port 4 ref coupler to front-panel REF 4 SOURCE OUT
- W39 (N5247-20035) A31 port 4 ref coupler to front-panel port 4 SOURCE OUT
- W49 (N5247-20073) Port 4 RCVR D IN to A28 mixer brick (D)
- W56 (N5247-20055) REF 2 RCVR R2 IN to A27 mixer brick (R2)
- W45 (N5247-20076) A32 port 2 ref coupler to front-panel REF 2 SOURCE OUT
- W40 (N5247-20017) Port 4 CPLR THRU to A35 port 4 coupler
- W43 (N5247-20036) A32 port 2 ref coupler to front-panel port 2 SOURCE OUT
- W44 (N5247-20018) Port 2 CPLR THRU to A36 port 2 coupler
- W50 (N5247-20054) Port 2 RCVR B IN to A27 mixer brick (B)

1. See ["Downloading the Online PNA Service Guide"](#) on page 5.

These cables must be saved - they will be reinstalled.

- W24 (N5247-20061) A63 port 2 70 GHz doubler to W23
 - W20 (N5247-20015) A62 port 4 70 GHz doubler to W19
 - W12 (N5247-20059) A60 port 1 70 GHz doubler to W11
 - W16 (N5247-20060) A61 port 3 70 GHz doubler to W15
 - W52 (N5247-20012) REF 1 RCVR R1 IN to A37 reference mixer switch
 - W51 (N5247-20011) A37 reference mixer switch to front-panel REF 1 SOURCE OUT
3. Leave the gray flexible cables, the wire harnesses, and the ribbon cables connected where possible. Any that are removed should be labeled for reconnection later.

Step 6. Remove Port 1 and Port 2 Reference Coupler Assemblies from the Test Set Deck

For instructions on removing the reference coupler assemblies, click the Chapter 7 bookmark “Removing and Replacing the A29-A32 Reference Couplers and Reference Coupler Mounting Brackets” in the PDF Service Guide¹. Save the parts for reinstallation later.

Step 7. Swap Brackets on the Port 1 and Port 2 Reference Coupler Assemblies

Remove the brackets from the reference coupler assemblies being careful to remember which bracket was removed from each reference coupler. Reinstall the bracket that had been installed on the Port 1 Reference Coupler Assembly onto the Port 2 Reference Coupler Assembly. Next, reinstall the bracket that had been installed on the Port 2 Coupler Assembly onto the Port 1 Reference Coupler Assembly.

Step 8. Remove Port 3 and Port 4 Reference Coupler Assemblies from the Test Set Deck

For instructions on removing the reference coupler assemblies, click the Chapter 7 bookmark “Removing and Replacing the A29-A32 Reference Couplers and Reference Coupler Mounting Brackets” in the PDF Service Guide¹. Save the parts for reinstallation later.

Step 9. Swap Brackets on the Port 3 and Port 4 Reference Coupler Assemblies

Remove the brackets from the reference coupler assemblies being careful to remember which bracket was removed from each reference coupler. Reinstall the bracket that had been installed on the Port 1 Reference Coupler Assembly onto the Port 2 Reference Coupler Assembly. Next, reinstall the bracket that had been installed on the Port 2 Coupler Assembly onto the Port 1 Reference Coupler Assembly.

1. See [“Downloading the Online PNA Service Guide”](#) on page 5.

Step 10. Assemble the Port 2 and Port 3 Step Attenuators

Refer to [Figure 1](#) for this step of the procedure. New parts are listed in [Table 1 on page 7](#). Use a T-10 TORX driver to tighten all screws.

Figure 1 Port 2 and Port 3 Step Attenuators Assembly

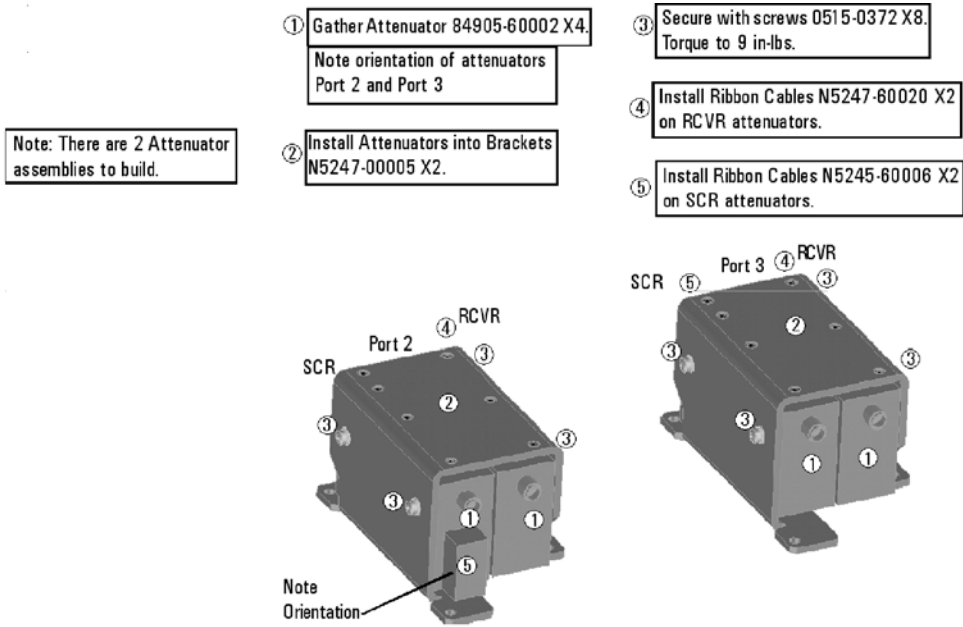

N5247_103_01a

Step 11. Install the Port 2 and Port 3 Step Attenuators

Refer to [Figure 2](#) for this step of the procedure. New parts are listed in [Table 1 on page 7](#). Use a T-10 TORX driver to tighten all screws.

Figure 2 Port 2 and Port 3 Step Attenuators Installation

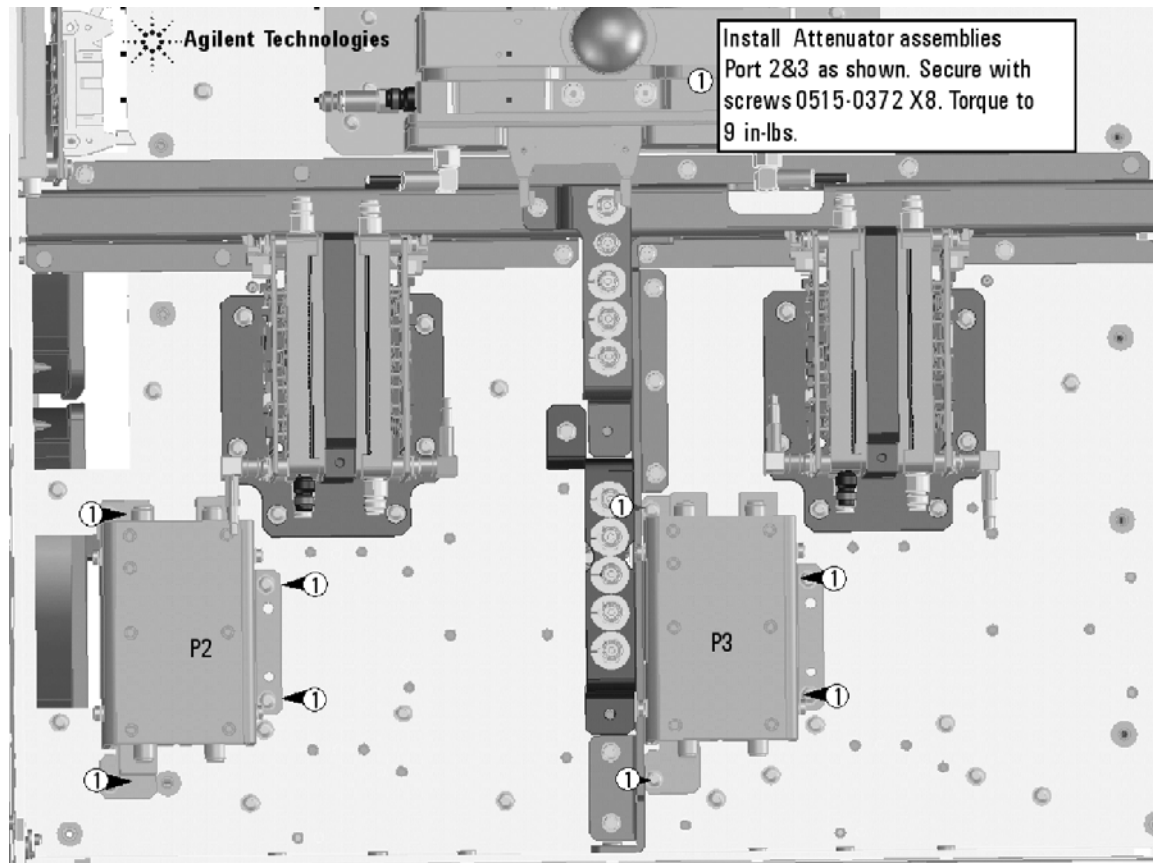

N5247_103_02

Step 12. Assemble the Port 1 and Port 4 Step Attenuators

Refer to [Figure 3](#) for this step of the procedure. New parts are listed in [Table 1 on page 7](#). Use a T-10 TORX driver to tighten all screws.

Figure 3 Port 1 and Port 4 Step Attenuators Assembly



Note: There are 2 Attenuator assemblies to build.

- ① Gather Attenuator 84905-60002 X4.
Note orientation of attenuators Port 2 and Port 3
- ② Install Attenuators into Brackets N5247-00005 X2.

- ③ Secure with screws 0515-0372 X8.
Torque to 9 in-lbs.
- ④ Install Ribbon Cables N5245-60006 X2 on SCR attenuators.
- ⑤ Install Ribbon Cables N5247-60020 X2 on RCVR attenuators.

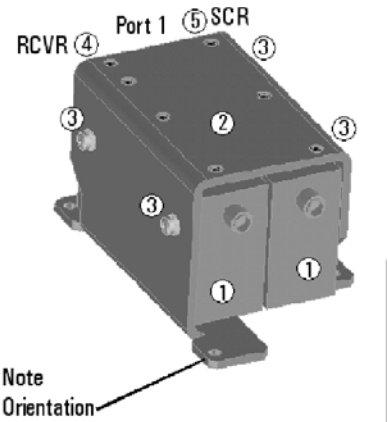
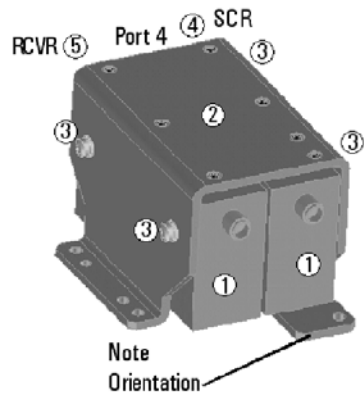

N5247_103_04

Step 13. Install the Port 1 and Port 4 Step Attenuators

Refer to [Figure 4](#) for this step of the procedure, but ignore the images of the Ports 2 and 3 reference coupler assemblies because they have not yet been installed. New parts are listed in [Table 1 on page 7](#). Use a T-10 TORX driver to tighten all screws.

Figure 4 Port 1 and Port 4 Step Attenuators Installation

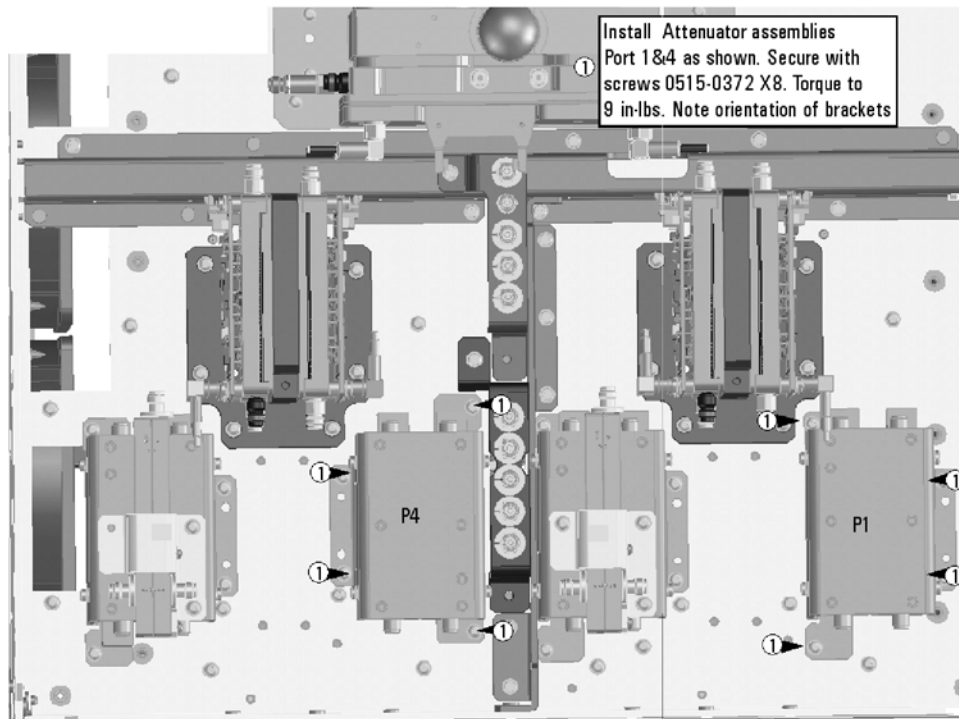

N5247_103_05

Step 14. Reinstall the Port 1, Port 2, Port 3 and Port 4 Reference Coupler Assemblies

Refer to [Figure 5](#) for this step of the procedure. Use a T-10 TORX driver to tighten all screws.

Figure 5 Port 1, Port 2, Port 3, and Port 4 Reference Coupler Assemblies Reinstallation

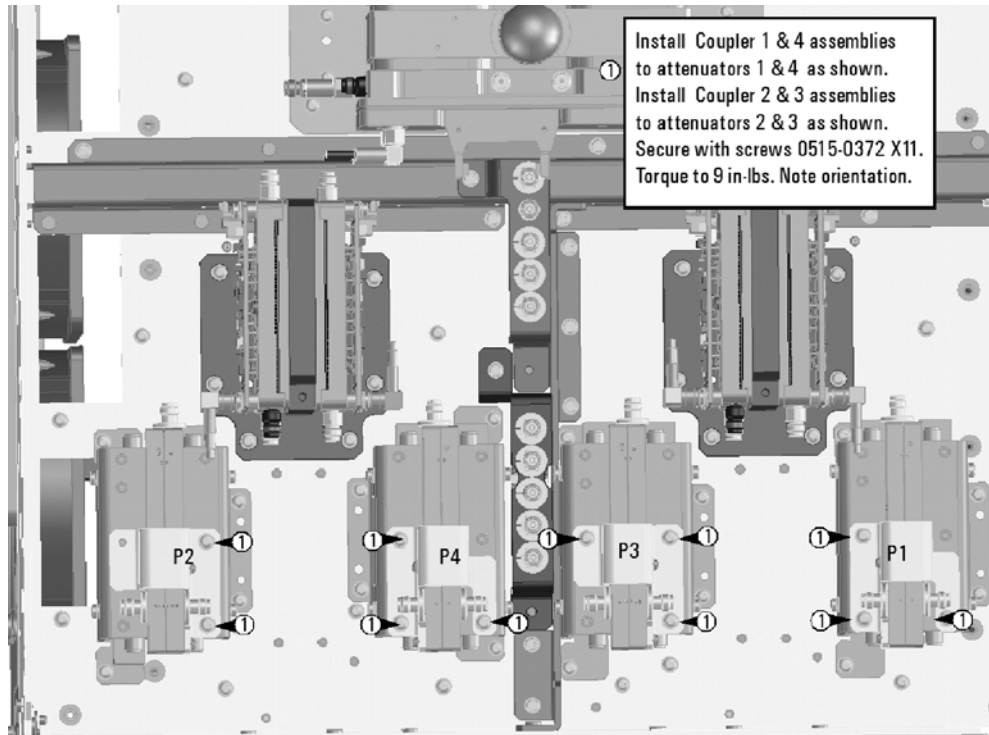

N5247_103_06

Step 15. Assemble the Bias Tees

Refer to [Figure 6](#) for this step of the procedure. New parts are listed in [Table 1 on page 7](#).

Figure 6 Bias Tee Assembly

NOTE: there are two bias tee assemblies to be built.

- ① Gather Bias Tee 5087-7732, and install Bracket N5247-20129 X2. Secure with screws 0515-1227 X8. Torque to 9 in-lbs.

Note: Orientation of Bracket and Bias Tee.

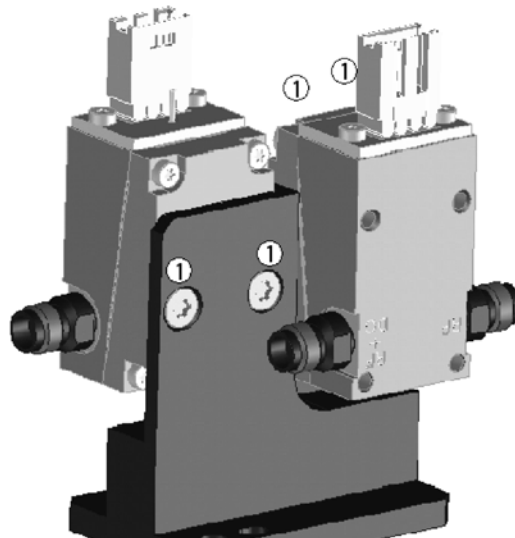

Step 16. Install the Bias Tee Assemblies

Refer to [Figure 7](#) for this step of the procedure. New parts are listed in [Table 1 on page 7](#).

Figure 7 Bias Tee Installation

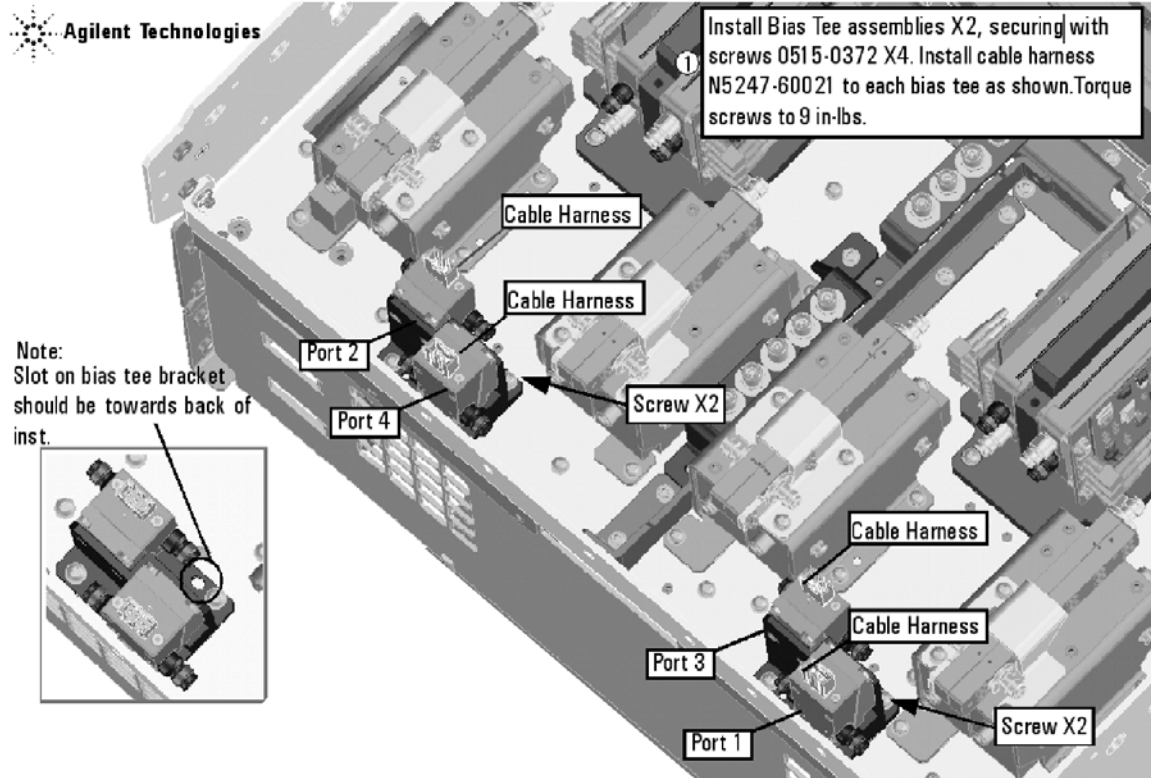

N5247_103_08

Step 17. Install Some Bottom-Side (Test Set) Cables

CAUTION Follow instructions carefully when making cable connections, especially wire harness connections. Incorrect connections can destroy components, resulting in additional customer costs.

CAUTION Be careful not to damage the center pins of the semirigid cables. Some flexing of the cables may be necessary but do not over-bend them.

Install the Semirigid Cables

To see an image showing the location of these cables, click the Chapter 6 bookmarks “Bottom RF Cables, 4-Port Configuration, Option 419” in the PDF Service Guide¹. New parts are listed in [Table 1 on page 7](#).

Install the following new cables in the order listed.

- W123 (N5247-20020) Port 2 RCVR B IN to A49 port 2 receiver attenuator
- W115 (N5247-20027) Port 2 CPLR THRU to A45 port 2 bias tee
- W114 (N5247-20034) A41 port 2 source attenuator to front-panel port 2 SOURCE OUT
- W112 (N5247-20029) A44 port 4 bias tee to A35 port 4 coupler

1. See [“Downloading the Online PNA Service Guide” on page 5](#).

- W146 (N5247-20058) A32 port 2 ref coupler to front-panel REF 2 SOURCE OUT
- * As shown in **Figure 8**, install three clamps, part number 1400-1334, to secure W146.

Figure 8 Location of Cable Clamps to Secure W146 (N5247-20058)

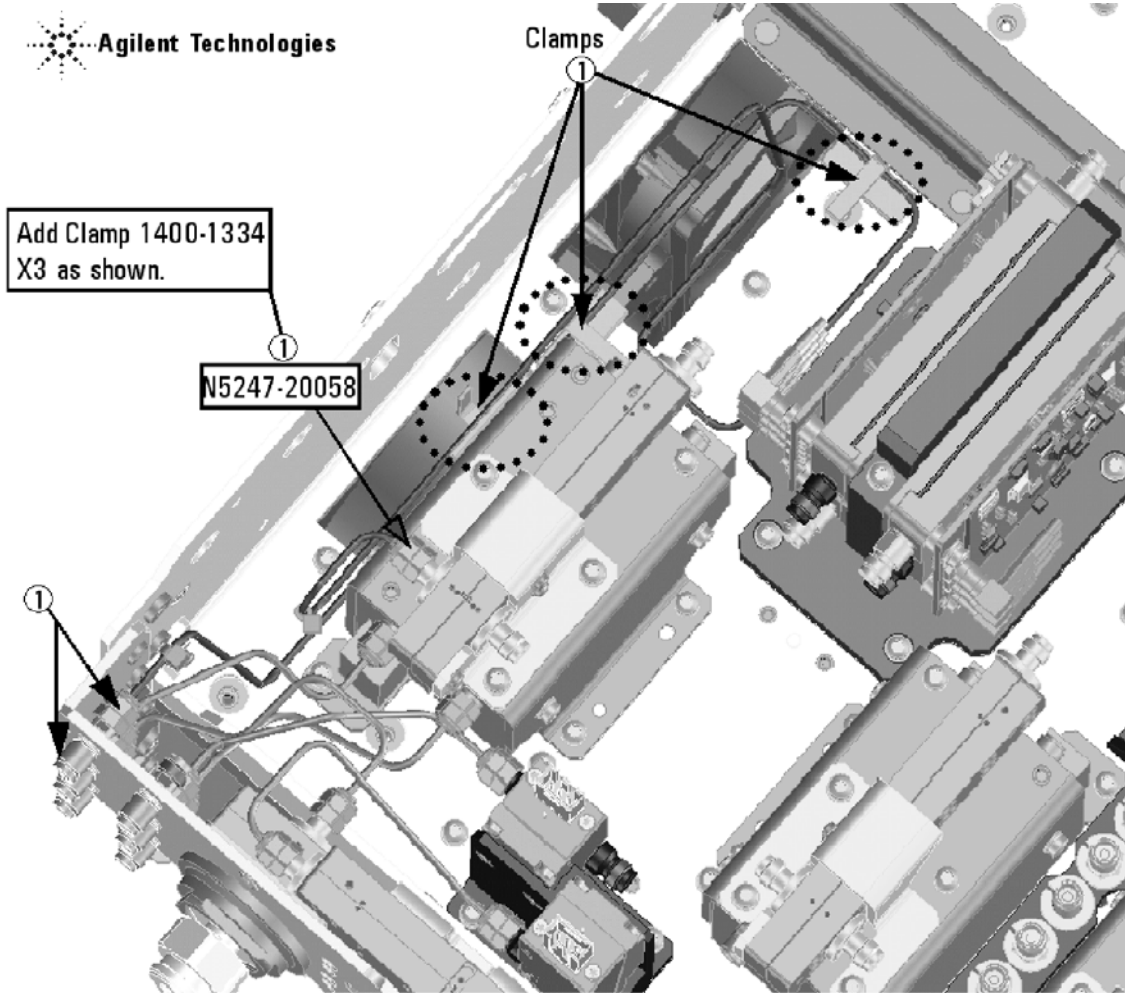

N5247_103_09

- W124 (N5247-20046) A49 port 2 receiver attenuator to A27 mixer brick (B)

- W145 (N5245-20066) REF 2 RCVR R2 IN to A27 mixer brick (R2)
- * As shown in **Figure 9**, install one clamp, part number 1400-1334, to secure W145 (N5245-20066).

Figure 9 Location of Cable Clamp to Secure W145 (N5247-20066)

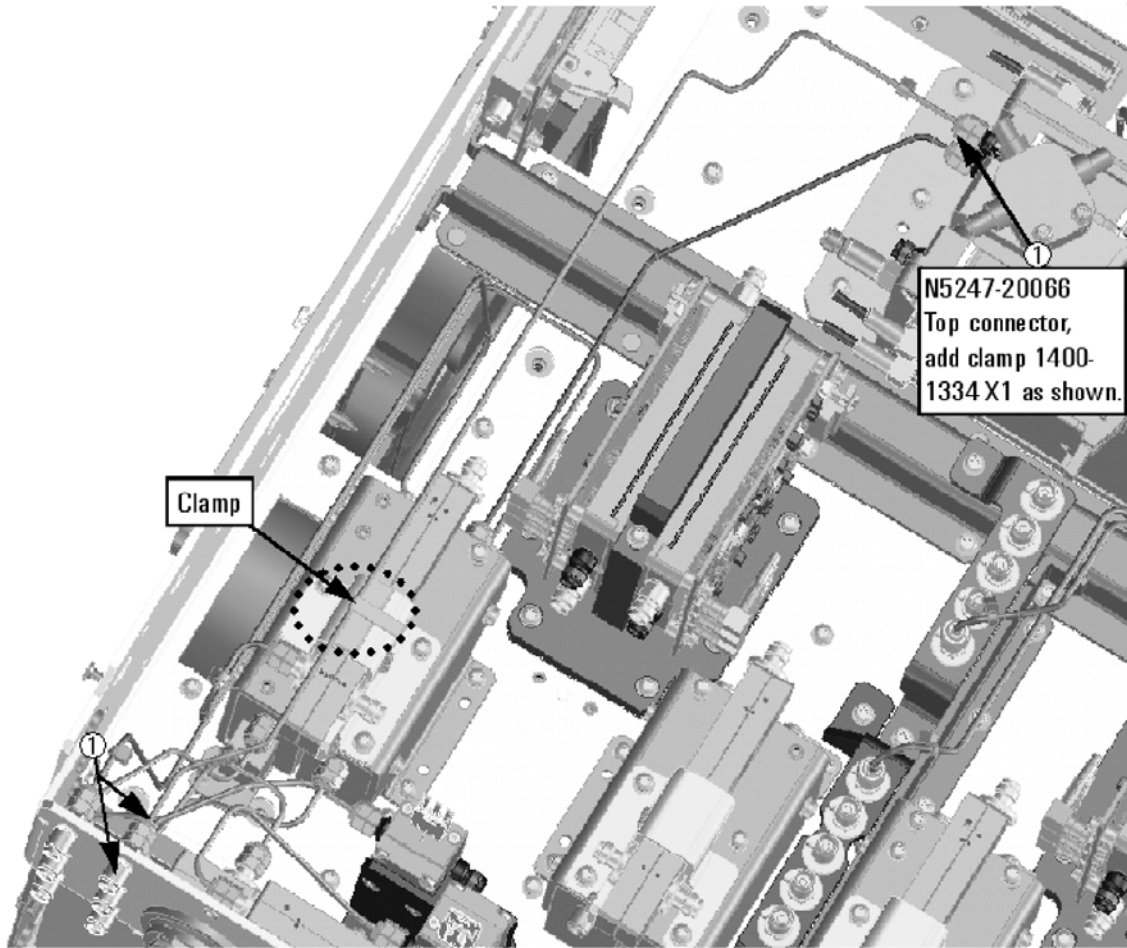

N5247_103_10

- W116 (N5247-20080) A45 port 2 bias tee to A36 port 2 coupler
- W121 (N5247-20024) Port 4 RCVR D IN to A48 port 4 receiver attenuator
- W111 (N5247-20021) Port 4 CPLR THRU to A44 port 4 bias tee
- W110 (N5247-20025) A40 port 4 source attenuator to front-panel port 4 SOURCE OUT

- W41 (N5247-20069) A31 port 4 reference coupler to front-panel REF 4 SOURCE OUT
- * As shown in **Figure 10**, install one clamp, part number 1400-1334, to secure W41 (N5247-20069).

Figure 10 Location of Cable Clamp to Secure W41 (N5247-20069)



N5227_106_02

- W104 (N5247-20022) A33 port 1 coupler to A42 port 1 bias tee
- W119 (N5247-20008) Port 3 RCVR C IN to A47 port 3 receiver attenuator
- W106 (N5247-20009) A39 port 3 source attenuator to front-panel port 3 SOURCE OUT
- W103 (N5247-20010) Front-panel port 1 CPLR THRU to A42 port 1 bias tee

- W37 (N5247-20070) A30 port 3 reference coupler to front-panel REF 3 SOURCE OUT
- * As shown in **Figure 11**, install one clamp, part number 1400-1334, to secure W37 (N5247-20070).

Figure 11 Location of Cable Clamp to Secure W37 (N5247-20070)

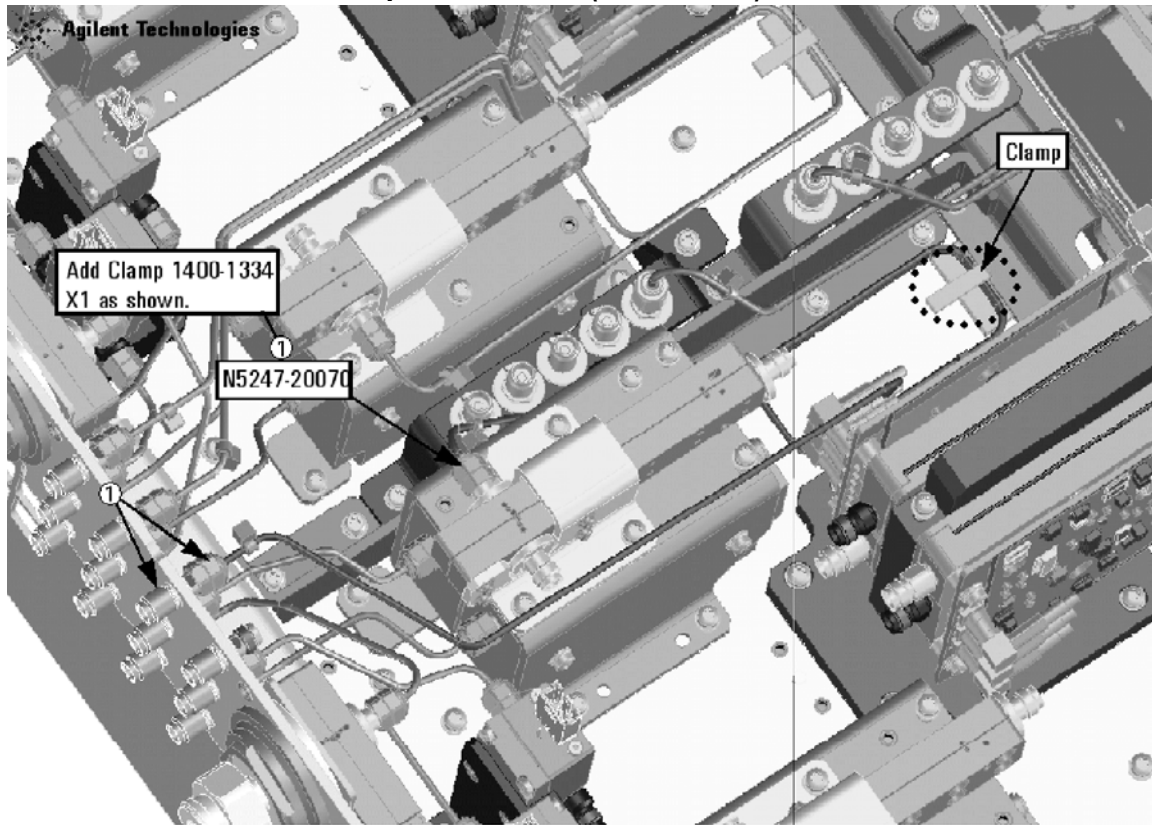

N5247 103 12

- W120 (N5247-20064) A47 port 3 receiver attenuator to A28 mixer brick (C)
- * As shown in **Figure 12**, install two cable ties, part number 1400-0249, to secure W120 (N5247-20064).

Figure 12 Location of Cable Ties to Secure W120 (N5247-20064)

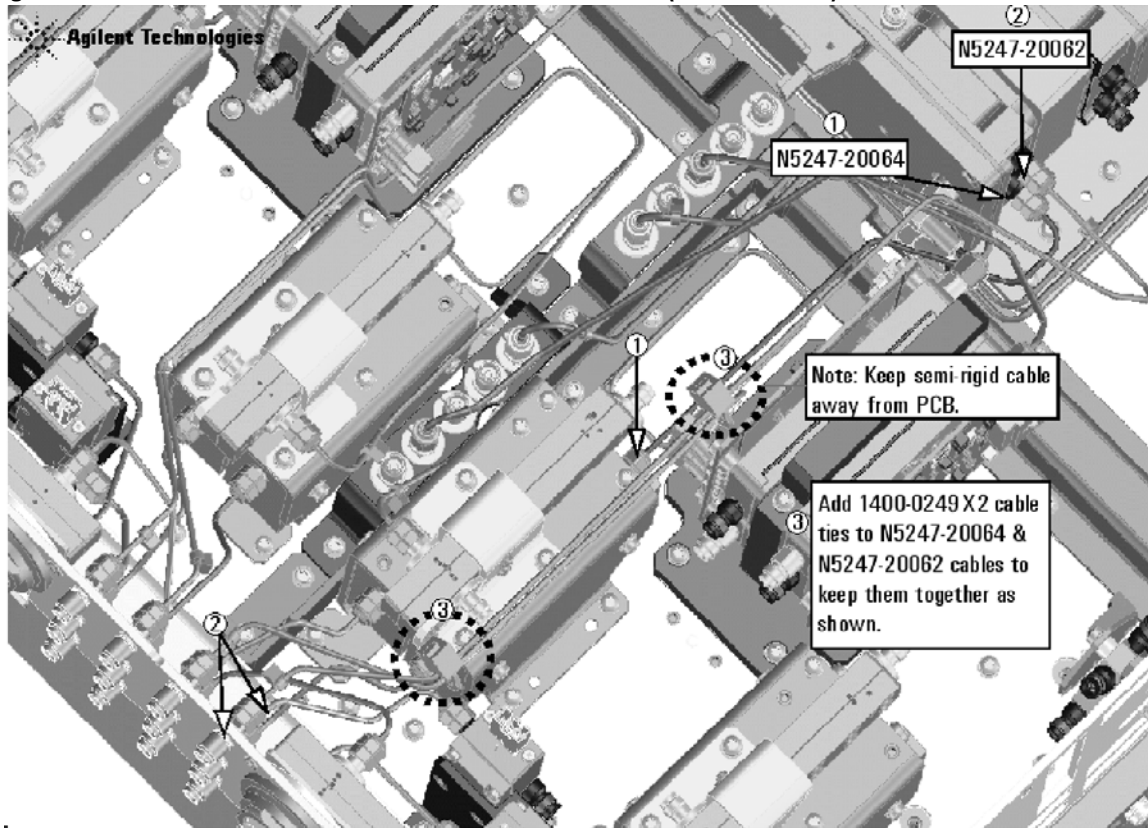

N5247 103 13

- W107 (N5247-20081) Port 3 CPLR THRU to A43 port 3 bias tee
- W117 (N5247-20013) Front-panel port 1 RCVR A IN to A46 port 1 receiver attenuator
- W102 (N5247-20014) A38 port 1 source attenuator to front-panel port 1 SOURCE OUT
- W108 (N5247-20028) A43 port 3 bias tee to A34 port 3 coupler

- W144 (N5247-20071) A29 port 1 reference coupler to A37 reference mixer switch
- * As shown in **Figure 13**, install 2 cable ties, part number 1400-0249, to secure W144 (N5247-20071).

Figure 13 Location of Cable Ties to Secure W144 (N5247-20071), Dust Cap, and Cable Clamp to Secure W52 (N5247-20012)

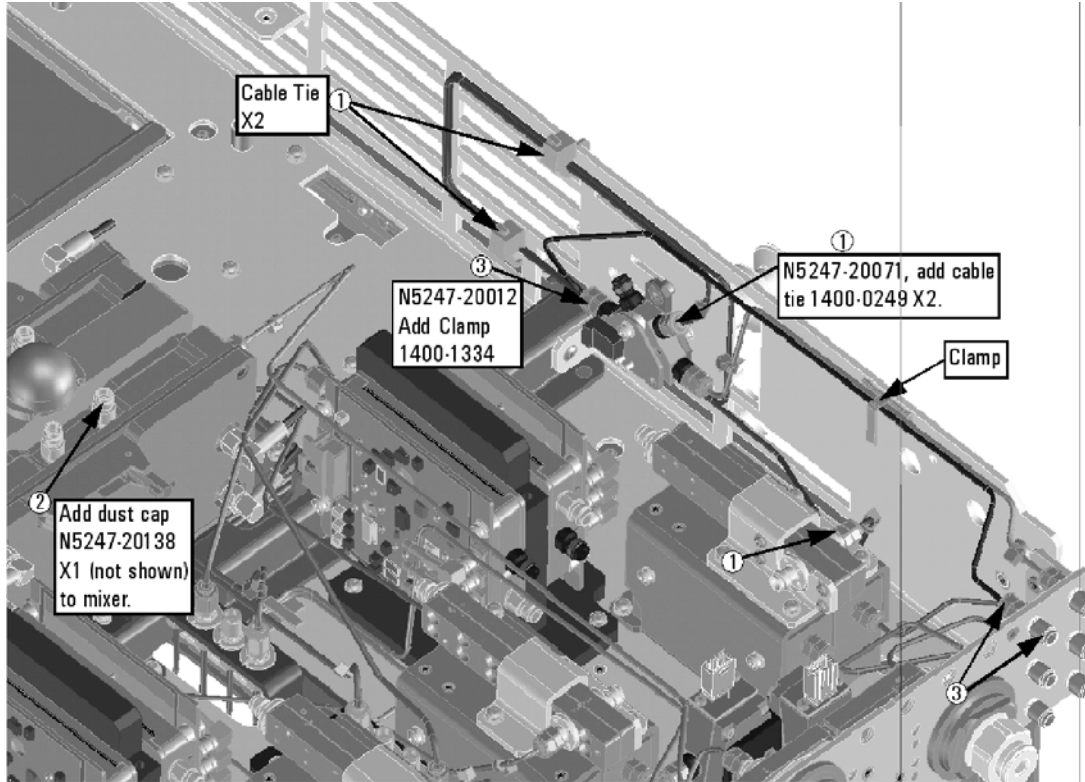

N5227_106_01

- -- (N5247-20138) Dust cap
- * As shown in **Figure 13**, install dust cap, part number N5247-20138, to mixer.
- W51 (reuse) (N5247-20011) A37 reference mixer switch to front-panel REF 1 SOURCE OUT
- W52 (reuse) (N5247-20012) REF 1 RCVR R1 IN to A37 reference mixer switch
- * As shown in **Figure 13**, install 1 cable clamp, part number 1400-1334, to secure W52 (N5247-20012). When done connecting cables to the reference mixer switch, torque the screws on the switch to 9 in-lbs.
- W118 (N5247-20047) A46 port 1 receiver attenuator to A27 mixer brick (A)
- W122 (N5247-20065) A48 port 4 receiver attenuator to A28 mixer brick (D)
- W101 (N5247-20083) A29 port 1 reference coupler to A38 port 1 source attenuator
- W113 (N5247-20083) A32 port 2 reference coupler to A41 port 2 source attenuator
- W109 (N5247-20083) A31 port 4 reference coupler to A40 port 4 source attenuator
- W105 (N5247-20083) A30 port 3 receiver coupler to A39 port 3 source attenuator

- W27 (N5247-20044) A60 port 1 70 GHz doubler to A29 port 1 reference coupler
- W16 (reuse) (N5247-20060) A61 port 3 70 GHz doubler to W15
- W28 (N5247-20043) A61 port 3 70 GHz doubler to A30 port 3 reference coupler
- W12 (reuse) (N5247-20059) A60 port 1 70 GHz doubler to W11
- W29 (N5247-20044) A62 port 4 70 GHz doubler to A31 port 4 reference coupler
- W20 (reuse) (N5247-20015) A62 port 4 70 GHz doubler to W19
- W24 (reuse) (N5247-20061) A63 port 2 70 GHz doubler to W23
- W30 (N5247-20043) A63 port 2 70 GHz doubler to A32 port 2 reference coupler

Install the Ribbon Cables and Wire Harnesses

To see an image showing the location of these cables, click the Chapter 6 bookmarks “Bottom Ribbon Cables and Wire Harnesses, 4-Port, Option 419” in the PDF Service Guide¹. New parts are listed in [Table 1 on page 7](#).

1. If not already done, connect step attenuator ribbon cables as follows:
 - N5245-60006 A38 port 1 source step attenuator to A23 test set motherboard J549
 - N5245-60006 A39 port 3 source step attenuator to A23 test set motherboard J547
 - N5245-60006 A40 port 4 source step attenuator to A23 test set motherboard J548
 - N5245-60006 A41 port 2 source step attenuator to A23 test set motherboard J546
 - N5247-60020 A46 port 1 receiver step attenuator to A23 test set motherboard J205
 - N5247-60020 A47 port 3 receiver step attenuator to A23 test set motherboard J206
 - N5247-60020 A48 port 4 receiver step attenuator to A23 test set motherboard J207
 - N5247-60020 A49 port 2 receiver step attenuator to A23 test set motherboard J208.
2. If not already done, connect bias tee cable harnesses as follows:
 - N5247-60021 A42 port 1 bias tee to A23 test set motherboard J541
 - N5247-60021 A43 port 3 bias tee to A23 test set motherboard J543
 - N5247-60021 A44 port 4 bias tee to A23 test set motherboard J544
 - N5247-60021 A45 port 2 bias tee to A23 test set motherboard J542

1. See [“Downloading the Online PNA Service Guide” on page 5](#).

Step 18. Install the Braces

Refer to [Figure 14](#) for this step of the procedure. New parts are listed in [Table 1](#) on page 7.

Figure 14 Brace Installation

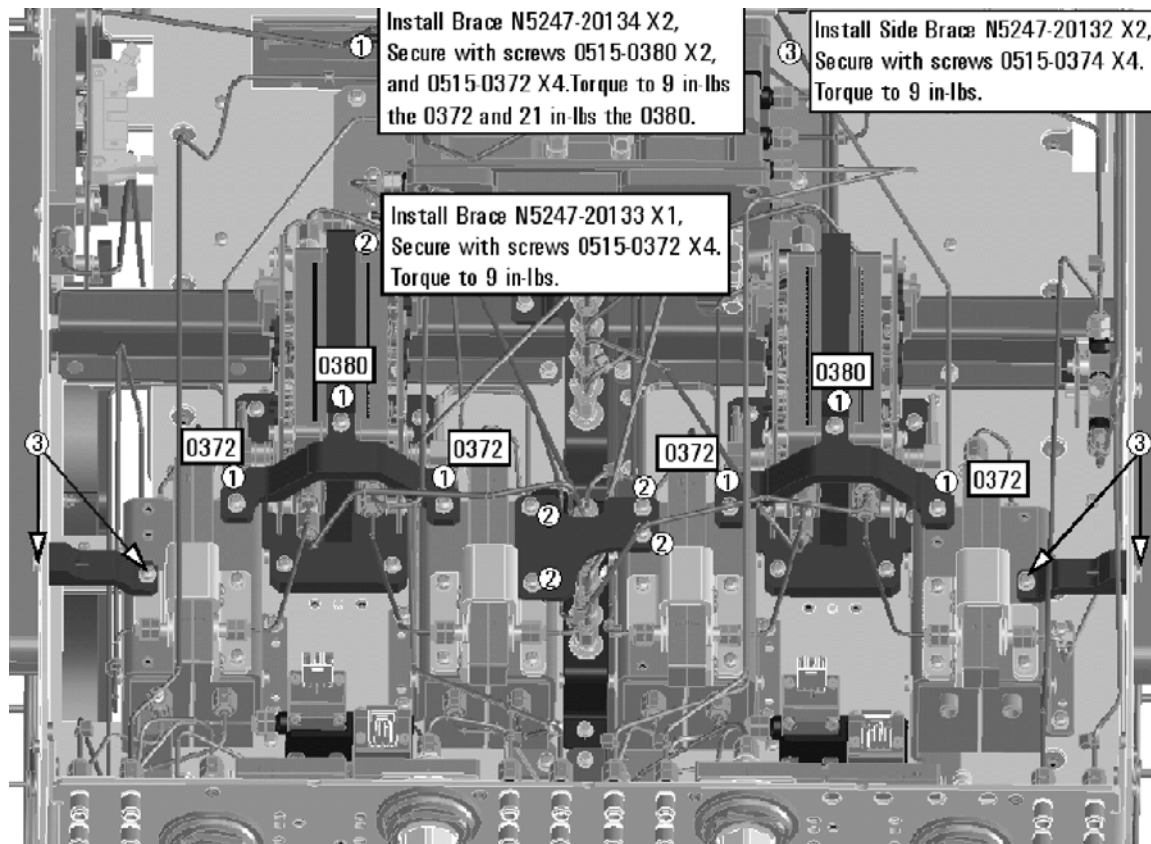

N5247_103_15

Step 19. Reinstall Front Panel Assembly

For instructions on reinstalling the front panel assembly, click the Chapter 7 bookmark “Removing and Replacing the Front Panel Assembly” in the PDF Service Guide¹.

Step 20. Position the Cables and Wires to Prevent Pinching

On the top side of the PNA, carefully position the grey flex cables so they can't be pinched between the covers and the rails.

On the bottom side of the PNA, carefully fold or push down the ribbon cables and wires so they can't be pinched between the hardware and the outer cover. Ribbon cables and wires must never be positioned on top of hardware.

Step 21. Reinstall the Inner Cover

For instructions, click the Chapter 7 bookmark “Removing the Covers” in the PDF Service Guide¹.

Step 22. Reinstall the Outer Cover

For instructions, click the Chapter 7 bookmark “Removing the Covers” in the PDF Service Guide¹.

Step 23. Enable Option 419

Procedure Requirements

- The analyzer must be powered up and operating to perform this procedure.
- The Network Analyzer program must be running.
- A keyboard must be connected to the network analyzer.

Option Enable Procedure

1. To start the option enable utility, press UTILITY **System**, then **Service**, then **Option Enable**. An option enable dialog box will appear.
2. Click the arrow in the **Select Desired Option** box. A list of available options will appear.
3. In the **Select Desired Option** list, click **419 - Src/Rcvr Atten & Bias Ts 4-Port**.
4. Using the keyboard, enter the license key in the box provided. The license key is printed on the the license message you received from Keysight. Enter this key *exactly* as it is printed on the message.
5. Click **Enable**.
6. Click **Yes** in answer to the displayed question in the **Restart Analyzer?** box.
7. When the installation is complete, click **Exit**.

Option Verification Procedure

Once the analyzer has restarted and the Network Analyzer program is again running:

1. On the analyzer’s **Help** menu, click **About Network Analyzer**.
2. Verify that “419” is listed after “Options:” in the display. Click **OK**.

NOTE If Option 419 has not been enabled, perform the “**Option Enable Procedure**” again. If the option is still not enabled, contact Keysight Technologies. Refer to “**Getting Assistance from Keysight**” on page 3.

Step 24. Perform Post-Upgrade Adjustments and Calibration

Adjustments

The following adjustments must be made due to the hardware changes of the analyzer.

- source adjustment
- receiver adjustment

These adjustments are described in the PNA Service Guide and in the PNA on-line HELP. A list of equipment required to perform these adjustments is also found in the service guide.

To view this service guide information, click the Chapter 3 bookmark “Tests and Adjustments” in the PDF Service Guide¹.

After the specified adjustments have been performed, the analyzer should operate and phase lock over its entire frequency range.

Operator’s Check

Perform the Operator’s Check to check the basic functionality of the analyzer. For instructions, click the Chapter 3 bookmark “Tests and Adjustments” in the PDF Service Guide¹.

If you experience difficulty with the basic functioning of the analyzer, contact Keysight. Refer to [“Contacting Keysight” on page 3](#).

Calibration

Although the analyzer functions, its performance relative to its specifications has not been verified. It is recommended that a full instrument calibration be performed using the analyzer’s internal performance test software. To view information on the performance test software, click the Chapter 3 bookmark “Tests and Adjustments” in the PDF Service Guide¹.

Step 25. Prepare the PNA for the User

1. If necessary, reinstall front jumper cables.
2. Install the cable guards, pushing them over the front jumper cables until the cushioning material touches the front panel of the PNA.
3. Install the dust caps on the test ports.
4. Clean the analyzer, as needed, using a damp cloth.

1. See [“Downloading the Online PNA Service Guide” on page 5](#).

This information is subject to change without notice.
© Keysight Technologies 2009 - 2014
August 2014



N5227-90106
www.keysight.com