

Keysight Second Source, Combiner, and Mechanical Switches Upgrade Kit

To Upgrade PNA-X N5241A, N5242A, or N5249A
Option 419 to Option 423

Upgrade Kit Order Number: N5241AU- 927,
N5242AU- 927, and N5249AU- 927

Keysight Kit Number: N5242-60104

NOTICE: This document contains references to Agilent Technologies. Agilent's former Test and Measurement business has become Keysight Technologies. For more information, go to www.keysight.com.



WARRANTY STATEMENT

THE MATERIAL CONTAINED IN THIS DOCUMENT IS PROVIDED "AS IS," AND IS SUBJECT TO BEING CHANGED, WITHOUT NOTICE, IN FUTURE EDITIONS. FURTHER, TO THE MAXIMUM EXTENT PERMITTED BY APPLICABLE LAW, KEYSIGHT DISCLAIMS ALL WARRANTIES, EITHER EXPRESS OR IMPLIED WITH REGARD TO THIS MANUAL AND ANY INFORMATION CONTAINED HEREIN, INCLUDING BUT NOT LIMITED TO THE IMPLIED WARRANTIES OF MERCHANTABILITY AND FITNESS FOR A PARTICULAR PURPOSE. KEYSIGHT SHALL NOT BE LIABLE FOR ERRORS OR FOR INCIDENTAL OR CONSEQUENTIAL DAMAGES IN CONNECTION WITH THE FURNISHING, USE, OR PERFORMANCE OF THIS DOCUMENT OR ANY INFORMATION CONTAINED HEREIN. SHOULD KEYSIGHT AND THE USER HAVE A SEPARATE WRITTEN AGREEMENT WITH WARRANTY TERMS COVERING THE MATERIAL IN THIS DOCUMENT THAT CONFLICT WITH THESE TERMS, THE WARRANTY TERMS IN THE SEPARATE AGREEMENT WILL CONTROL.

DFARS/Restricted Rights Notice

If software is for use in the performance of a U.S. Government prime contract or subcontract, Software is delivered and licensed as "Commercial computer software" as defined in DFAR 252.227-7014 (June 1995), or as a "commercial item" as defined in FAR 2.101(a) or as "Restricted computer software" as defined in FAR 52.227-19 (June 1987) or any equivalent agency regulation or contract clause. Use, duplication or disclosure of Software is subject to Keysight Technologies' standard commercial license terms, and non-DOD Departments and Agencies of the U.S. Government will receive no greater than Restricted Rights as defined in FAR 52.227-19(c)(1-2) (June 1987). U.S. Government users will receive no greater than Limited Rights as defined in FAR 52.227-14 (June 1987) or DFAR 252.227-7015 (b)(2) (November 1995), as applicable in any technical data.

Safety Notes

The following safety notes are used throughout this document. Familiarize yourself with each of these notes and its meaning before performing any of the procedures in this document.

WARNING	Warning denotes a hazard. It calls attention to a procedure which, if not correctly performed or adhered to, could result in injury or loss of life. Do not proceed beyond a warning note until the indicated conditions are fully understood and met.
----------------	---

CAUTION	Caution denotes a hazard. It calls attention to a procedure that, if not correctly performed or adhered to, could result in damage to or destruction of the instrument. Do not proceed beyond a caution sign until the indicated conditions are fully understood and met.
----------------	---

Getting Assistance from Keysight

By internet or phone, get assistance with all your test and measurement needs.

Contacting Keysight

Assistance with test and measurements needs and information on finding a local Keysight office are available on the Web at:

<http://www.keysight.com/find/assist>

If you do not have access to the Internet, please contact your Keysight field engineer.

NOTE In any correspondence or telephone conversation, refer to the Keysight product by its model number and full serial number. With this information, the Keysight representative can determine whether your product is still within its warranty period.

If You Have Problems With the Upgrade Kit Contents

Keysight stands behind the quality of the upgrade kit contents. If you have problems with any item in the kit, email Keysight Component Test Division (CTD) Support at support_ctd-soco@keysight.com, or telephone the CTD Hotline at (707) 577-6802 and leave a voice mail message. Please include details of the problem.

Description of the Upgrade

This upgrade converts your Option 419 4-port analyzer (with configurable test set, extended power range, and bias tees) to an Option 423 analyzer by adding a mechanical switch to each source port channel and a source combiner to the port 1 channel.

In addition, source outputs are routed to the rear panel and rear-panel test set inputs are added.

About Installing the Upgrade

Products affected	N5241A, N5242A, and N5249A Option 419
Installation to be performed by	Keysight service center or personnel qualified by Keysight
Estimated installation time	5.0 hours
Estimated adjustment time	0.5 hours
Estimated full instrument calibration time	4.5 hours

Items Included in the Upgrade Kit

Check the contents of your kit against the following list. If any part is missing or damaged, contact Keysight Technologies. Refer to [“Getting Assistance from Keysight” on page 3](#).

Table 1 Contents of Upgrade Kit N5242-60104

Ref Desig.	Description	Qty	Part Number
	Installation note (this document)		N5242-90005
A46	Port 1 mechanical switch	4	N1811-60028 Was N1811-60006
A47	Port 3 mechanical switch		
A48	Port 4 mechanical switch		
A49	Port 2 mechanical switch		
A50	Combiner (bridge)	1	5087-7757 Was 5087-7315
	Switch bracket	4	N5242-00009
	Machine screw, M2.5 x 20, pan head (to attach mechanical switch to switch bracket)	8	0515-1992
	Machine screw, M3.0 x 20, pan head (to attach combiner to switch bracket)	2	0515-1410
	Machine screw, M3.0 x 6, pan head (to attach switch bracket to analyzer)	8	0515-0430
	Cable tie wrap	3	1400-0249
	Bulkhead connector assembly for rear panel	11	1250-3805
W25	RF cable, REF 2 SOURCE OUT to A28 port 2 bridge	1	N5222-20038
W95	RF cable, W3 to A46 port 1 mechanical switch	1	N5242-20269
W96	RF cable, A46 port 1 mechanical switch to A25 test port 1 bridge	1	N5242-20264
W97	RF cable, A46 port 1 mechanical switch to rear-panel PORT 1 SW SRC OUT (J11)	1	N5242-20287
W98	RF cable, rear-panel PORT 1 COMB THRU IN (J10) to A50 combiner	1	N5242-20288
W99	RF cable, rear-panel PORT 1 COMB ARM IN (J9) to A50 combiner	1	N5242-20289
W100	RF cable, A50 combiner to A46 port 1 mechanical switch	1	N5242-20265
W101	RF cable, W5 to A47 port 3 mechanical switch	1	N5242-20266
W102	RF cable, A47 port 3 mechanical switch to A26 test port 3 bridge	1	N5242-20263
W103	RF cable, A47 port 3 mechanical switch to rear-panel PORT 3 SW SRC OUT (J8)	1	N5242-20282
W104	RF cable, rear-panel PORT 3 SW TSET IN (J7) to A47 port 3 mechanical switch	1	N5242-20281
W105	RF cable, W7 to A48 port 4 mechanical switch	1	N5242-20267
W106	RF cable, A48 port4 mechanical switch to A27 test port 4 bridge	1	N5242-20261
W107	RF cable, A48 port 4 mechanical switch to rear-panel PORT 4 SW SRC OUT (J4)	1	N5242-20283
W108	RF cable, rear-panel PORT 4 SW TSET IN (J3) to A48 port 4 mechanical switch	1	N5242-20284
W109	RF cable, W9 to A49 port 2 mechanical switch	1	N5242-20268

Table 1 Contents of Upgrade Kit N5242-60104

Ref Desig.	Description	Qty	Part Number
W110	RF cable, A49 port 2 mechanical switch to A28 test port 2 bridge	1	N5242-20262
W111	RF cable, A49 port 2 mechanical switch to rear-panel PORT 2 SW SRC OUT (J2)	1	N5242-20285
W112	RF cable, rear-panel PORT 2 SW TSET IN (J1) to A49 port 2 mechanical switch	1	N5242-20286
W113	Rear panel jumper	4	N5222-20091
W154	RF cable, front-panel REF 2 RCVR R2 IN to A23 mixer brick (R2)	1	N5242-20308

Installation Procedure for the Upgrade

The network analyzer must be in proper working condition prior to installing this option. Any necessary repairs must be made before proceeding with this installation.

WARNING This installation requires the removal of the analyzer's protective outer covers. The analyzer must be powered down and disconnected from the mains supply before performing this procedure.

Electrostatic Discharge Protection

Protection against electrostatic discharge (ESD) is essential while removing or connecting cables or assemblies within the network analyzer.

Static electricity can build up on your body and can easily damage sensitive internal circuit elements when discharged. Static discharges too small to be felt can cause permanent damage. To prevent damage to the instrument:

- *always* have a grounded, conductive table mat in front of your test equipment.
- *always* wear a grounded wrist strap, connected to a grounded conductive table mat, having a 1 M Ω resistor in series with it, when handling components and assemblies or when making connections.
- *always* wear a heel strap when working in an area with a conductive floor. If you are uncertain about the conductivity of your floor, wear a heel strap.
- *always* ground yourself before you clean, inspect, or make a connection to a static-sensitive device or test port. You can, for example, grasp the grounded outer shell of the test port or cable connector briefly.

Figure 1 shows a typical ESD protection setup using a grounded mat and wrist strap. Refer to “Tools and Equipment Required for the Installation” on page 7 for part numbers.

Figure 1 ESD Protection Setup

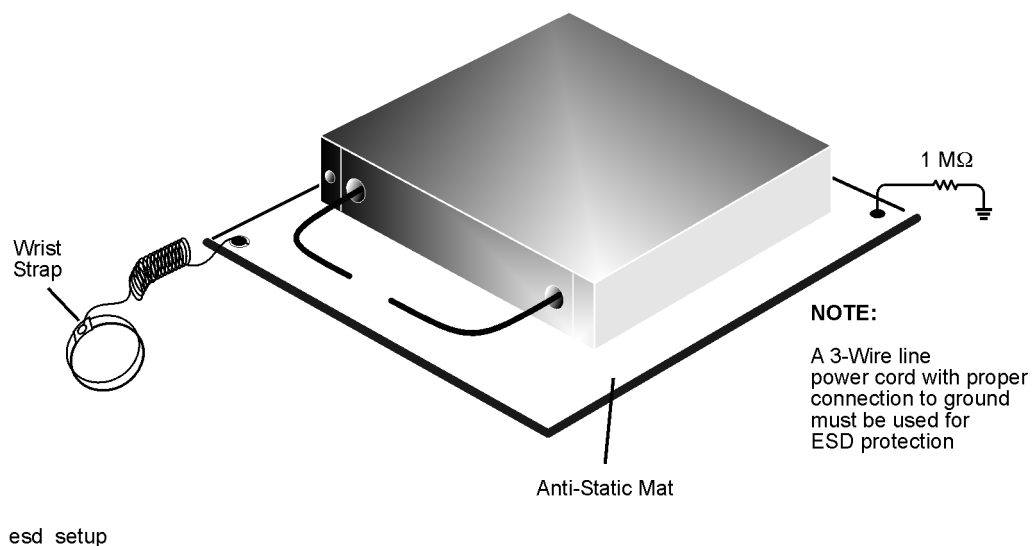

Tools and Equipment Required for the Installation

Description	Qty	Part Number
T-10 TORX driver (set to 9 in-lbs)	1	N/A
T-20 TORX driver (set to 21 in-lbs)	1	N/A
5/16-in torque wrench (set to 10 in-lbs)	1	N/A
5/16-in torque wrench (set to 21 in-lbs)	1	N/A

CAUTION Use a 5/16-in torque wrench set to 10 in-lbs on all cable connections except the front and rear panel cable connectors. Torque these connections to 21 in-lb.

ESD Equipment and Supplies Required for the Installation

Description	Keysight Part Number
ESD grounding wrist strap	9300-1367
5-ft grounding cord for wrist strap	9300-0980
2 x 4 ft conductive table mat and 15-ft grounding wire	9300-0797
ESD heel strap (for use with conductive floors)	9300-1308

Overview of the Installation Procedure

- Step 1. Remove the Outer Cover.
- Step 2. Remove the Front Panel Assembly.
- Step 3. Remove the Existing Test Set Cables.
- Step 4. Assemble the Mechanical Switches.
- Step 5. Install the Mechanical Switches.
- Step 6. Remove the A19 Test Set Motherboard and the A20 IF Multiplexer Board.
- Step 7. Install the Bulkhead Connectors and Jumpers on the Rear Panel.
- Step 8. Install the Bulkhead Connectors in the Test Set Front Plate (For Analyzers with Serial Numbers Prefixed MY/SG/US5310 and Below).
- Step 9. Install the New Test Set Cables.
- Step 10. Reinstall the A20 IF Multiplexer Board and the A19 Test Set Motherboard.
- Step 11. Reinstall the Front Panel Assembly and Front Panel Jumpers.
- Step 12. Position the Cables and Wires to Prevent Pinching.
- Step 13. Reinstall the Outer Cover.
- Step 14. Enable Option 423.
- Step 15. Perform Post-Upgrade Adjustments and Calibration.
- Step 16. Prepare the PNA for the User.

Step 1. Remove the Outer Cover

CAUTION This procedure is best performed with the analyzer resting on its front handles in the vertical position. *Do not place the analyzer on its front panel without the handles.* This will damage the front panel assemblies.

Refer to **Figure 2** for this step of the procedure.

1. Disconnect the power cord (if it has not already been disconnected).
2. Remove the strap handles (item ①) by loosening the screws (item ②), with a T-20 TORX driver, on both ends until the handle is free of the analyzer.
3. Remove the foot locks (item ③) from the four bottom feet (item ④) and then remove the four bottom feet from the outer cover.
4. Remove the four rear panel feet (item ⑤) by removing the center screws (item ⑥) with a T-20 TORX driver.
5. Slide the outer cover toward the rear of the analyzer and remove it.

Figure 2 Outer Cover Removal

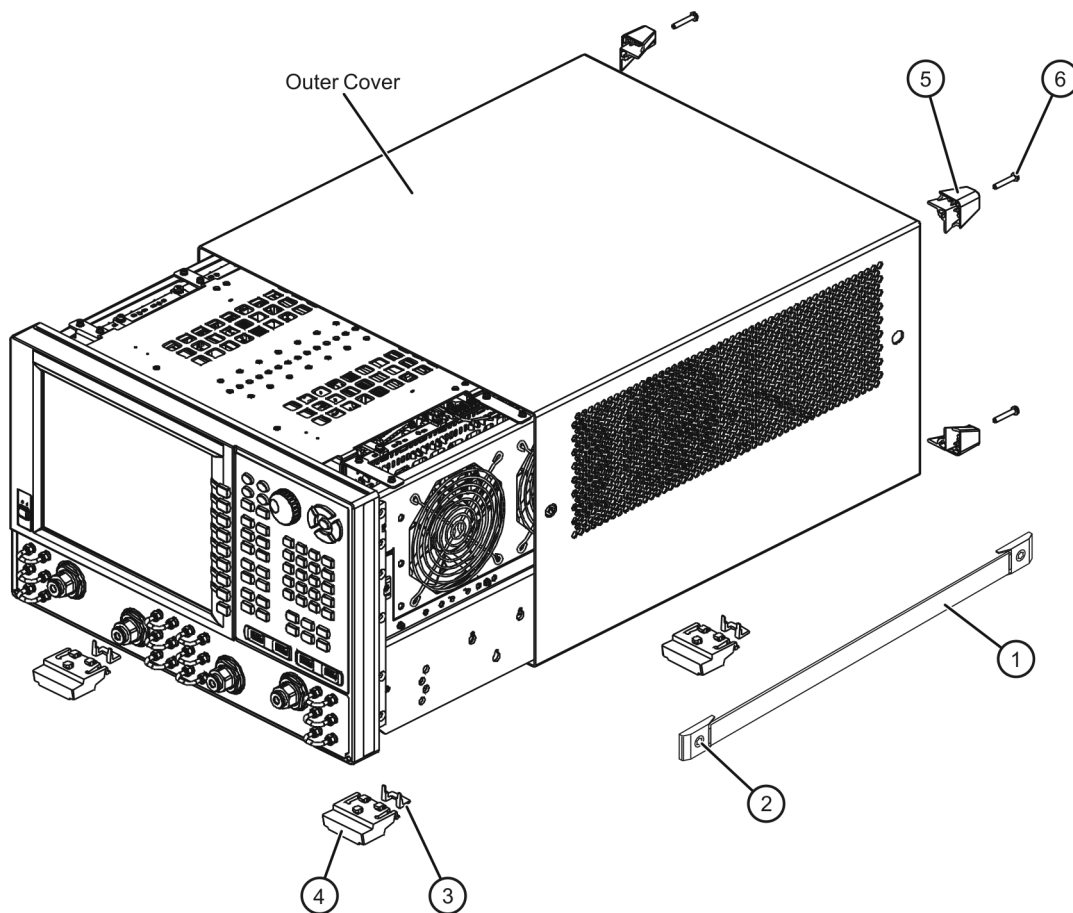

n5242_004_01

Step 2. Remove the Front Panel Assembly

Refer to **Figure 3** for this step of the procedure.

1. With a 5/16-in wrench, remove all front panel jumpers (item ①).
2. With a T-10 TORX driver, remove the screws (item ②) from the sides of the frame.

CAUTION Before removing the front panel from the analyzer, lift and support the front of the analyzer chassis.

3. Slide the front panel over the test port connectors.
4. Disconnect the front panel interface ribbon cable (item ③). The front panel is now free from the analyzer.

Figure 3 Front Panel Assembly Removal

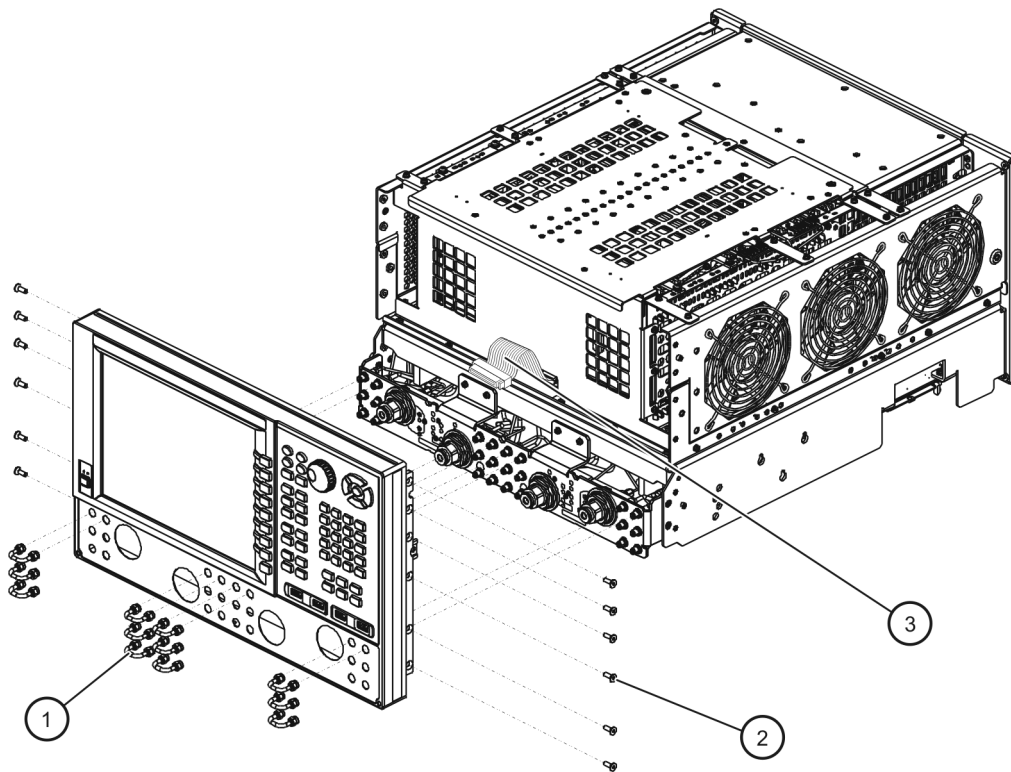

n5242_004_02

Step 3. Remove the Existing Test Set Cables

NOTE Leave the gray flexible cables, the wire harnesses, and the ribbon cables connected where possible. **Any that are removed should be labeled for reconnection later.**

CAUTION Be careful not to damage the center pins of the semirigid cables. Some flexing of the cables may be necessary but do not over-bend them.

Refer to [Figure 4](#) for this step of the procedure.

1. Place the analyzer bottom-side up on a flat surface.
2. Remove the following cables in the order listed:
 - W4 W3 (from A5 26.5 GHz source 1 board OUT 1) to A25 port 1 bridge
 - W6 W5 (from A8 26.5 GHz source 2 board OUT 1) to A26 port 3 bridge
 - W8 W7 (from A8 26.5 GHz source 2 board OUT 2) to A27 port 4 bridge
 - W10 W9 (from A5 26.5 GHz source 1 board OUT 2) to A28 port 2 bridge
 - W40 Front-panel REF 2 RCVR R2 IN to A23 mixer brick (R2)

For analyzers with serial numbers prefixed MY/SG/US5310 and below:

- W25 REF 2 SOURCE OUT to A28 port 2 bridge

Figure 4 Existing Test Set Cables Removal

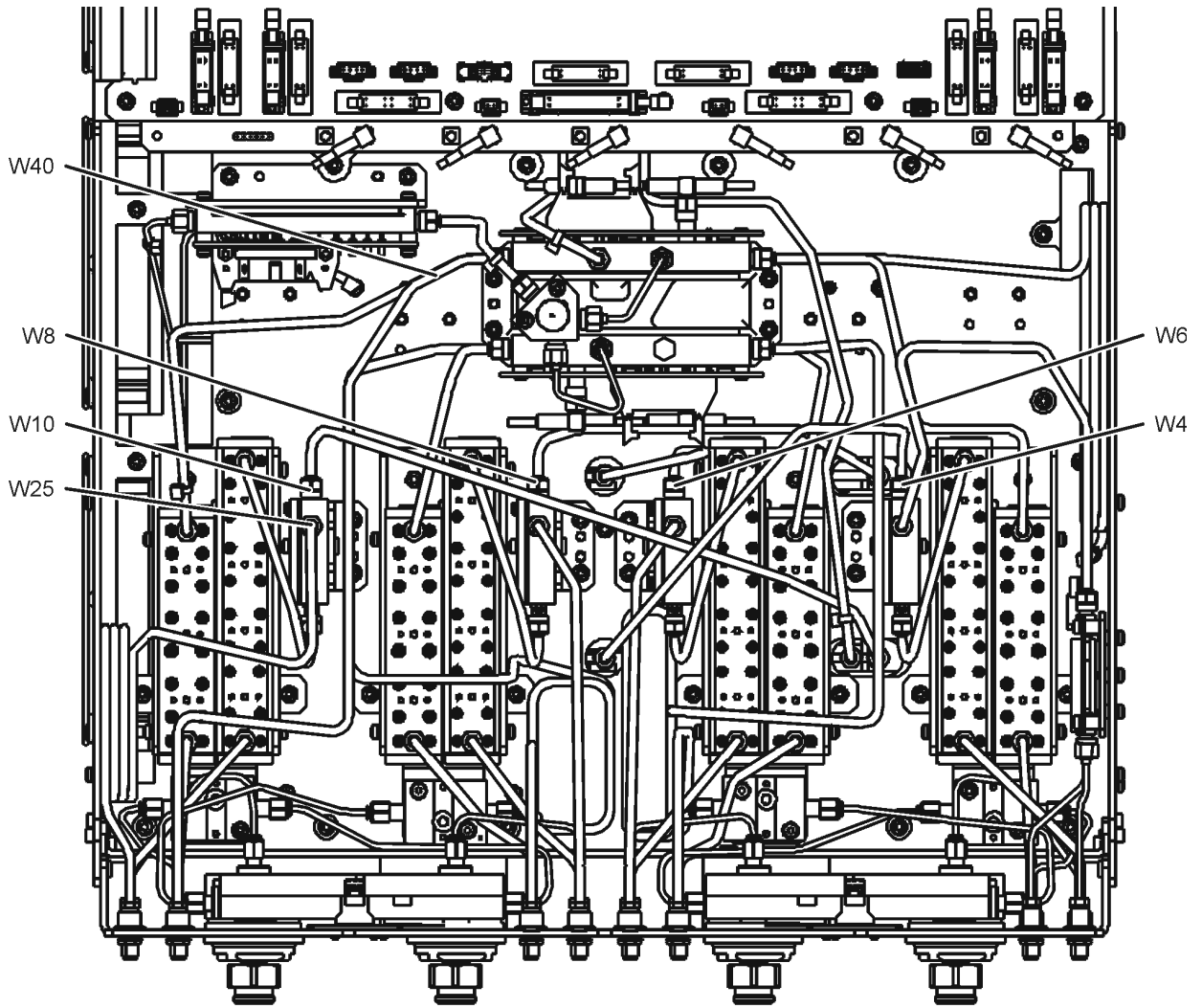

n5242_005_01

Step 4. Assemble the Mechanical Switches

Refer to [Figure 5](#) for this step of the procedure. New parts are listed in [Table 1](#) on [page 4](#).

1. Position each mechanical switch on a switch bracket as shown.
2. Secure each switch to its bracket using two screws (item ①, 0515-1992) for each. Make sure that the switches are oriented as shown.
3. Position the A50 combiner on one of the switch brackets as shown. This will be the bracket with the A46 port 1 mechanical switch.
4. Secure the A50 combiner to the bracket using two screws (item ②, 0515-1410). Make sure that the A50 combiner is oriented as shown.

Figure 5 Mechanical Switches Assembly

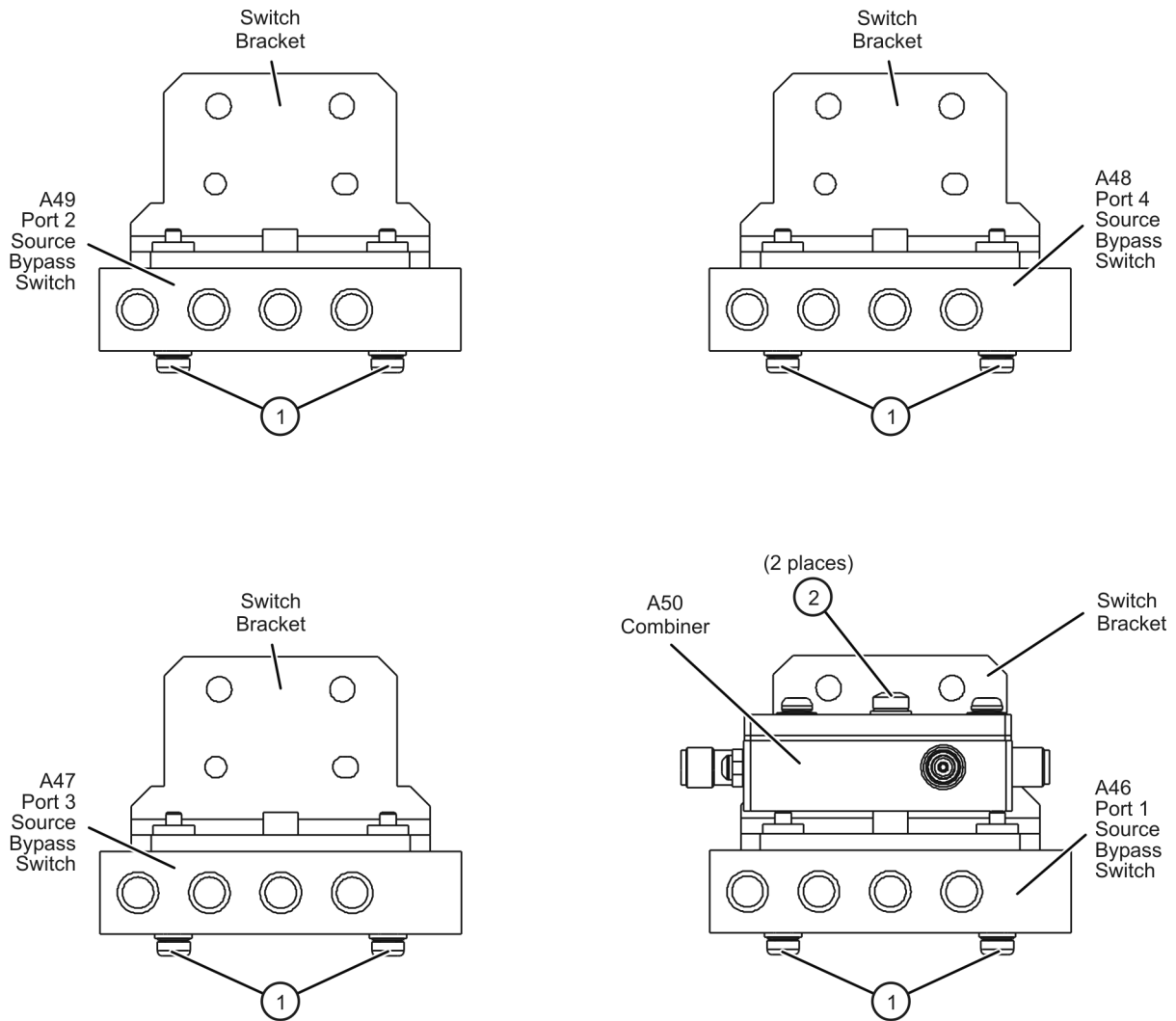

n5242_005_02

Step 5. Install the Mechanical Switches

Refer to [Figure 6](#) for this step of the procedure. New parts are listed in [Table 1 on page 4](#).

1. Position the switch brackets (with the switches and combiner attached) in the analyzer as shown. Make sure that the switch bracket with the A50 combiner is in the location shown.
2. Secure the switch brackets to the analyzer test set deck using two screws (item ①, 0515-0430) each.

Figure 6 Mechanical Switches Installation into the Analyzer

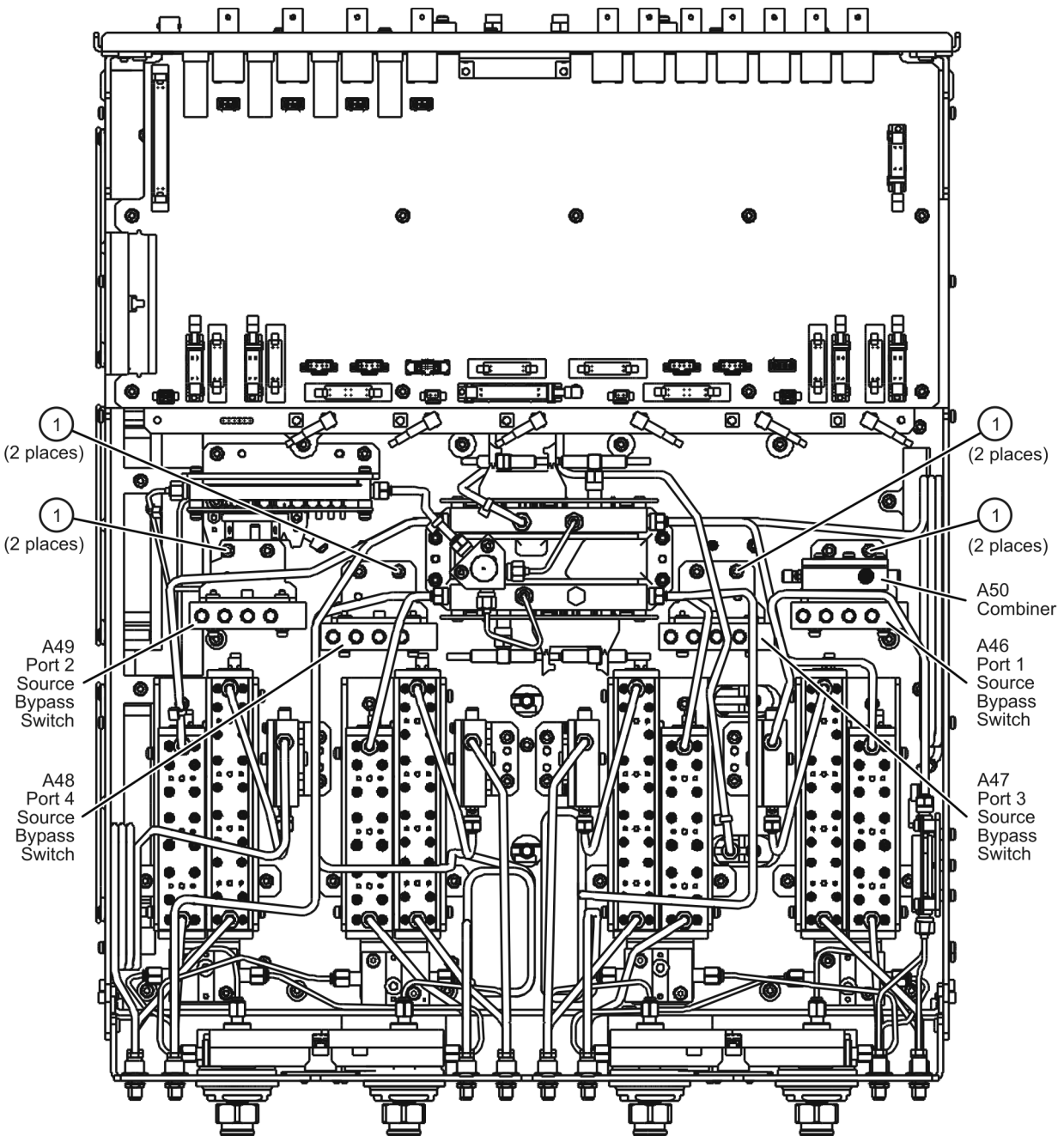

n5242_005_03

Step 6. Remove the A19 Test Set Motherboard and the A20 IF Multiplexer Board

Remove the A19 Test Set Motherboard

Refer to **Figure 7** for this part of this step of the procedure.

1. Disconnect ALL ribbon cables (item ①) and ALL wire harnesses (item ②) from the A19 test set motherboard. Make sure they are labeled for re-connection later.
2. Remove connector hardware (item ③) from 11 rear panel BNC connectors.
3. Remove connector hardware (item ④) from the rear panel TEST SET I/O connector.
4. Remove 10 screws (item ⑤) from the A19 test set motherboard.
5. Slide the A19 test set motherboard toward the front of the instrument until the rear panel BNC connectors are free of the rear panel, then lift the motherboard and remove it from the analyzer.

Figure 7 A19 Test Set Motherboard Removal

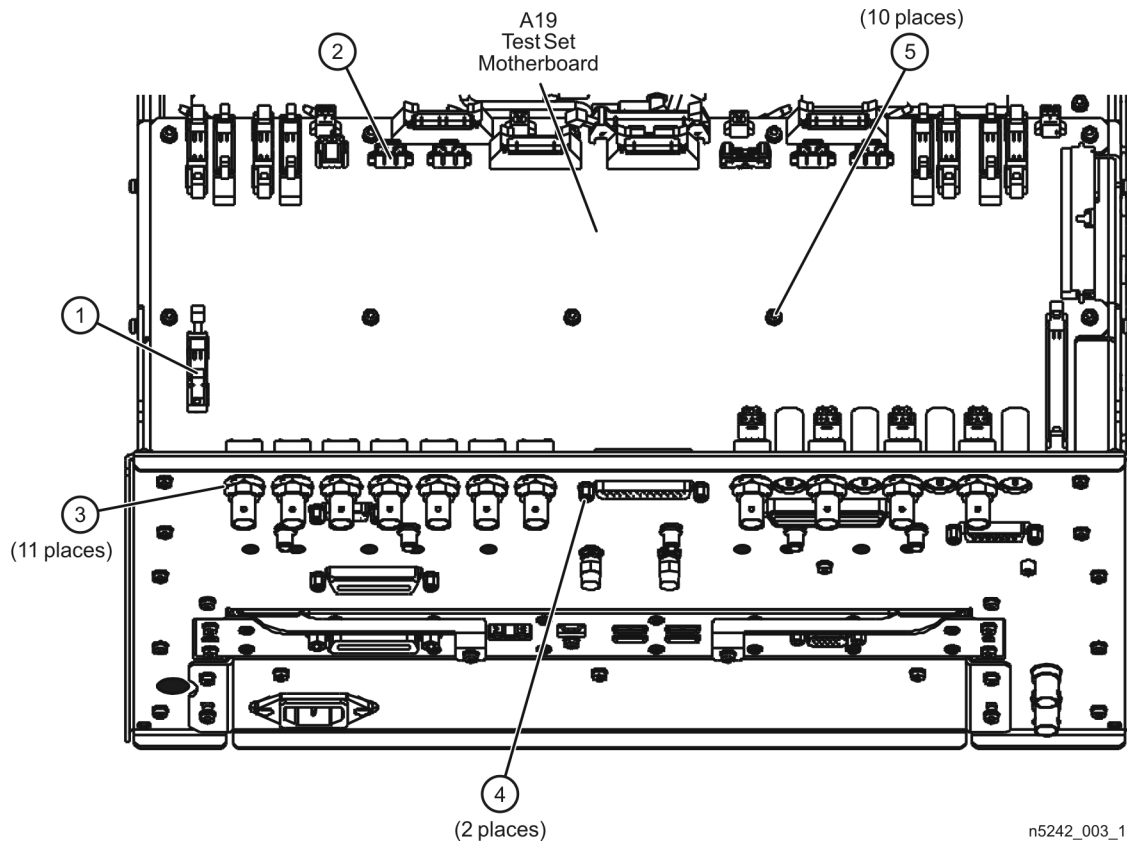

n5242_003_15

Remove the A20 IF Multiplexer Board

Refer to **Figure 8** for this part of this step of the procedure.

1. Disconnect the ribbon cable (item ①) from the A20 IF multiplexer board.
2. Disconnect ALL gray flexible RF cables (item ②) from the A20 IF multiplexer board. Make sure they are labeled for re-connection later.
3. Remove connector hardware (item ③) from five rear panel RF connectors.
4. Remove connector hardware (item ④) from the rear panel PULSE I/O connector.
5. Remove four screws (item ⑤) from the A20 IF multiplexer board.
6. Slide the A20 IF multiplexer board toward the front of the instrument until the rear panel connectors are free of the rear panel, then lift the board and remove it from the analyzer.

Figure 8 A20 IF Multiplexer Board Removal

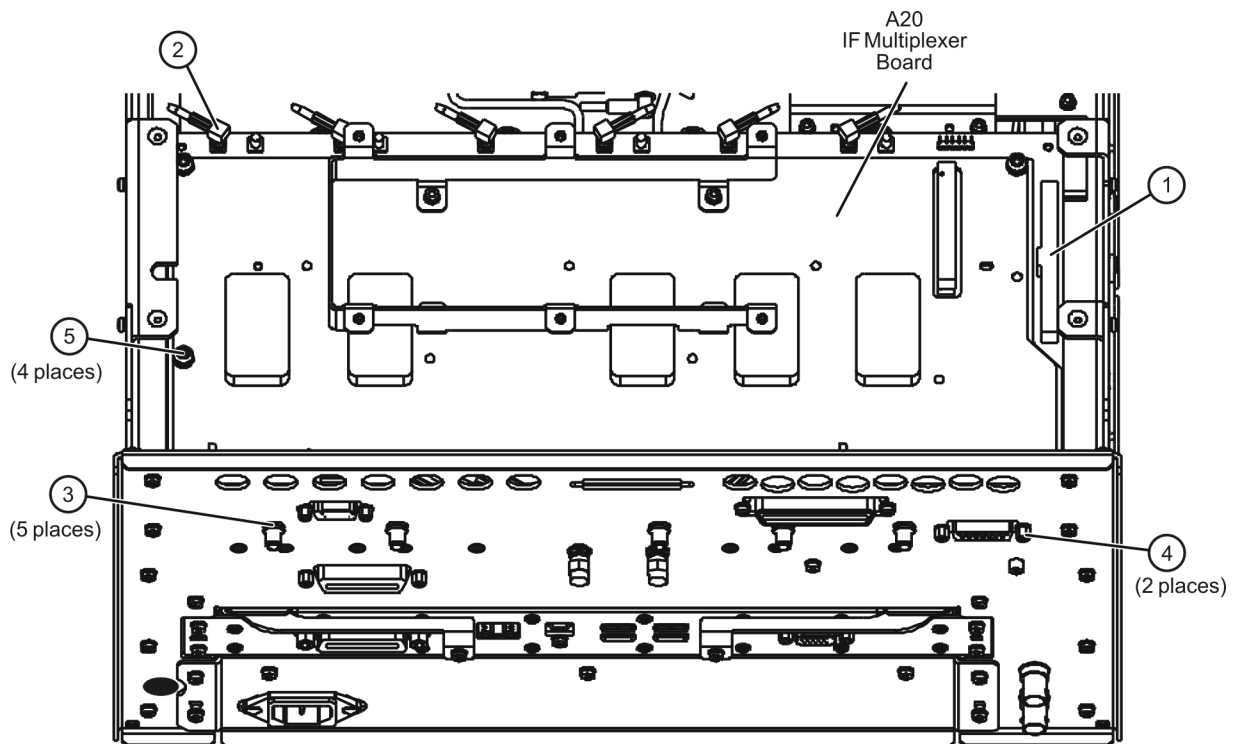

n5242_003_16

Step 7. Install the Bulkhead Connectors and Jumpers on the Rear Panel

1. Remove hole plugs from the following rear panel connector openings:
 - PORT 1—COMB ARM IN (J9) and COMB THRU IN (J10) and SW SRC OUT (J11)
 - SRC 2— SW SRC OUT (J8)
 - PORT 3—SW TSET IN (J7)
 - PORT 4—SW TSET IN (J3) and SW SRC OUT (J4)
 - PORT 2—SW TSET IN (J1) and SW SRC OUT (J2)

Refer to [Figure 9](#) for this part of this step of the procedure. New parts are listed in [Table 1](#) on page 4.

2. Install bulkhead connectors, lock washers (item ①) and hex nuts (item ②) for the seven new rear panel cables. These cables will be installed later.
3. Using a 5/16-in torque wrench set to 21 in-lbs, tighten the hex nuts on the bulkhead connectors.
4. Install the three rear panel jumpers, W113, in the locations shown (and as listed below) and torque the jumper connectors to 10 in-lbs:
 - a. Jumper PORT 1 COMB THRU IN (J10) to PORT 1 SW SRC OUT (J11)
 - b. Jumper PORT 1 COMB ARM IN (J9) to SRC 2 SW SRC OUT (J8)
 - c. Jumper PORT 4 SW TSET IN (J3) to PORT 4 SW SRC OUT (J4)
 - d. Jumper PORT 2 SW TSET IN (J1) to PORT 2 SW SRC OUT (J2)
5. Install a 50-ohm termination (item ③) on the PORT 3 SW TSET IN (J7) connector, as indicated, and torque the termination connector to 10 in-lbs.

Figure 9 Bulkhead Connectors and Jumpers on Rear Panel

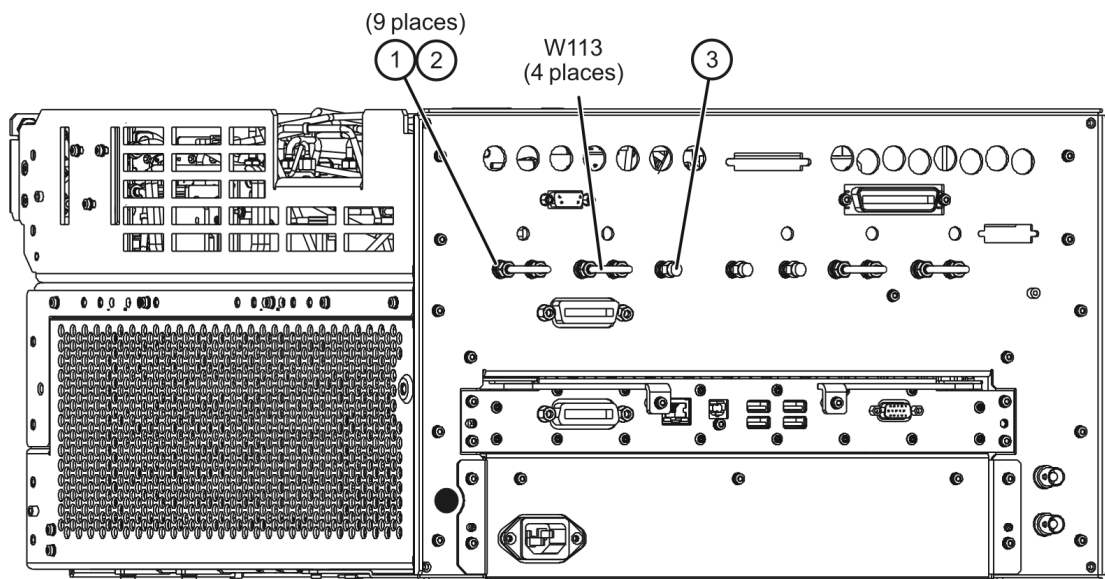

n5242_005_06

Step 8. Install the Bulkhead Connectors in the Test Set Front Plate (For Analyzers with Serial Numbers Prefixed MY/SG/US5310 and Below)

If your analyzer's serial number is MY/SG/US5321 and above, ignore this step.

Refer to [Figure 10](#) for this procedure. Some bulkhead connectors may already be installed on your analyzer's front plate. New parts are listed in [Table 1 on page 4](#).

1. From the back side of the test set front plate, insert a bulkhead connector into a hole in the plate.
2. Install 1x washer and 1x nut. Hand tighten nut and ensure bulkhead connector hexagon nut, on the back side of test set front plate, is aligned to the test set subpanel hexagon indent.
3. Repeat previous two steps for the remaining bulkhead connectors.
4. Torque nuts, on the front side of test set front plate, to 21 in-lbs.

Figure 10 Bulkhead Connectors Installation

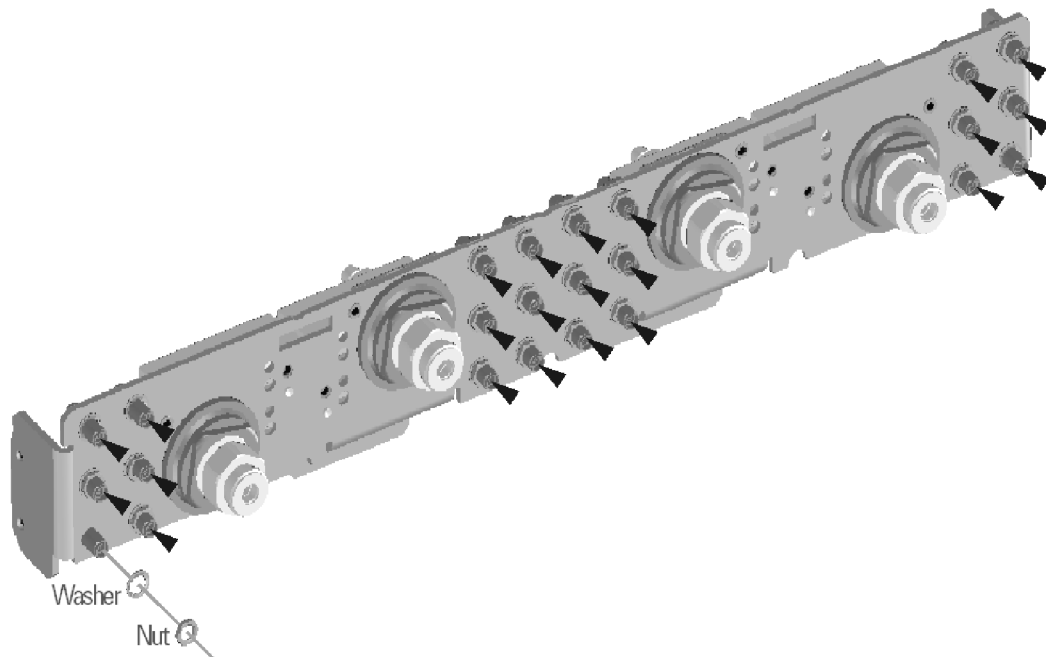

N5242_004_09

Step 9. Install the New Test Set Cables

CAUTION Follow instructions carefully when making cable connections, especially wire harness connections. Incorrect connections can destroy components, resulting in additional customer costs.

CAUTION Be careful not to damage the center pins of the semirigid cables. Some flexing of the cables may be necessary but do not over-bend them.

CAUTION Use a 5/16-in torque wrench set to 10 in-lbs on all cable connections except the front and rear panel bulkhead connectors. On these, use a 9 mm nutsetter or open end torque wrench set to 21 in-lb.

Refer to [Figure 11](#) for this part of this step. New parts are listed in [Table 1 on page 4](#).

Install the following cables in the order listed. Use a 5/16-in torque wrench set to 10 in-lbs to tighten all cable connectors.

- W95 (N5242-20269) W3 (from A5 26.5 GHz source 1 board) to A46 port 1 mechanical switch (connector 2)
- W96 (N5242-20264) A46 port 1 mechanical switch (connector 3) to A25 test port 1 bridge
- W97 (N5242-20287) A46 port 1 mechanical switch (connector 1) to rear-panel PORT 1 SW SRC OUT (J11)
- W98 (N5242-20288) Rear-panel PORT 1 COMB THRU IN (J10) to A50 combiner
- W99 (N5242-20289) Rear-panel PORT 1 COMB ARM IN (J9) to A50 combiner
- W100 (N5242-20265) A50 combiner to A46 port 1 mechanical switch (connector 4)
- W101 (N5242-20266) W5 (from A8 26.5 GHz source 2 board) to A47 port 3 mechanical switch (connector 2)
- W102 (N5242-20263) A47 port 3 mechanical switch (connector 3) to A26 test port 3 bridge
- W103 (N5242-20282) A47 port 3 mechanical switch (connector 1) to rear-panel SRC 2 SW SRC OUT (J8)
- W104 (N5242-20281) Rear-panel PORT 3 SW TSET IN (J7) to A47 port 3 mechanical switch (connector 4)
- W105 (N5242-20267) W7 (from A8 26.5 GHz source 2 board) to A48 port 4 mechanical switch (connector 2)
- W106 (N5242-20261) A48 port 4 mechanical switch (connector 3) to A27 test port 4 bridge
- W107 (N5242-20283) A48 port 4 mechanical switch (connector 1) to rear-panel PORT 4 SW SRC OUT (J4)
- W108 (N5242-20284) Rear-panel PORT 4 SW TSET IN (J3) to A48 port 4 mechanical switch (connector 4)
- W109 (N5242-20268) W9 (from A5 26.5 GHz source 1 board) to A49 port 2 mechanical switch (connector 2)

For analyzers with serial numbers prefixed MY/SG/US5310 and below:

- W25 (N5222-20038) A28 port 2 bridge to front-panel REF 2 SOURCE OUT

Secure W25 to the side of the deck with 1x cable tie wrap, part number 1400-0249 (included in the kit).

For all analyzer serial numbers:

- W154 (N5242-20308) front panel REF 2 RCVR R2 IN to A23 mixer brick (R2)
- W110 (N5242-20262) A49 port 2 mechanical switch (connector 3) to A28 test port 2 bridge
- W111 (N5242-20285) A49 port 2 mechanical switch (connector 1) to rear-panel PORT 2 SW SRC OUT (J2)
- W112 (N5242-20286) Rear-panel PORT 2 SW TSET IN (J1) to A49 port 2 mechanical switch (connector 4)

Figure 11

New Test Set Cable Installation

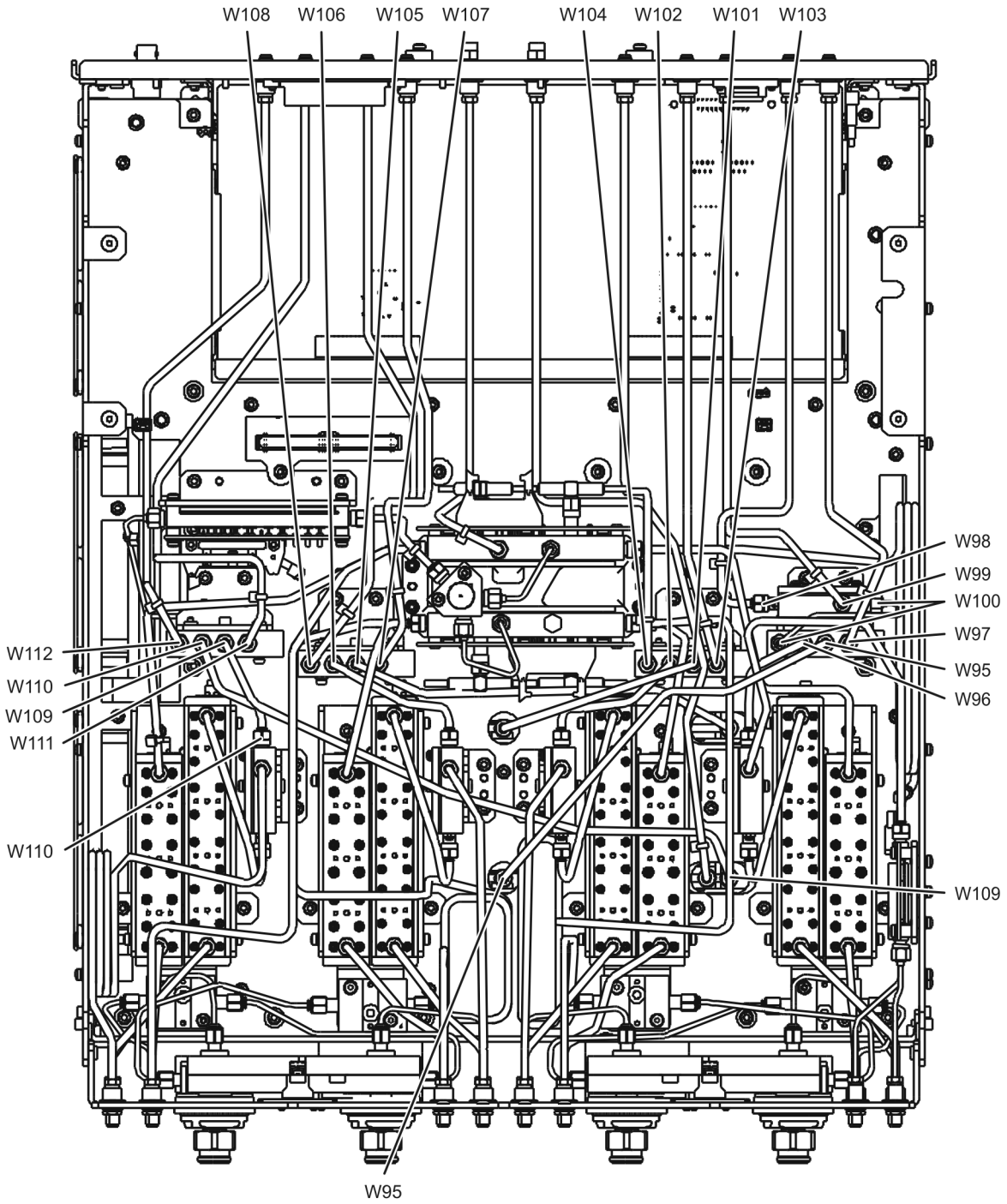

n5242_005_04

Step 10. Reinstall the A20 IF Multiplexer Board and the A19 Test Set Motherboard

Reinstall the A20 IF Multiplexer Board

Refer to **Figure 12** for this part of this step of the procedure.

1. Position the A20 IF multiplexer board in the analyzer and slide it toward the rear of the instrument until the rear panel connectors are completely through the rear panel.
2. *Loosely* reinstall four screws (item ⑤) in the A20 IF multiplexer board.
3. Reinstall connector hardware (item ③) on five rear panel RF connectors. Torque the hex nuts to 21 in-lbs.
4. Reinstall connector hardware (item ④) on the rear panel PULSE I/O connector. Torque the connector nuts to 6 in-lbs.
5. Torque the four screws (item ⑤) to 21 in-lbs.
6. Reconnect ALL gray flexible RF cables (item ②) to the A20 IF multiplexer board.
7. Reconnect the ribbon cable (item ①) to the A20 IF multiplexer board.

Figure 12 A20 IF Multiplexer Board Reinstallation

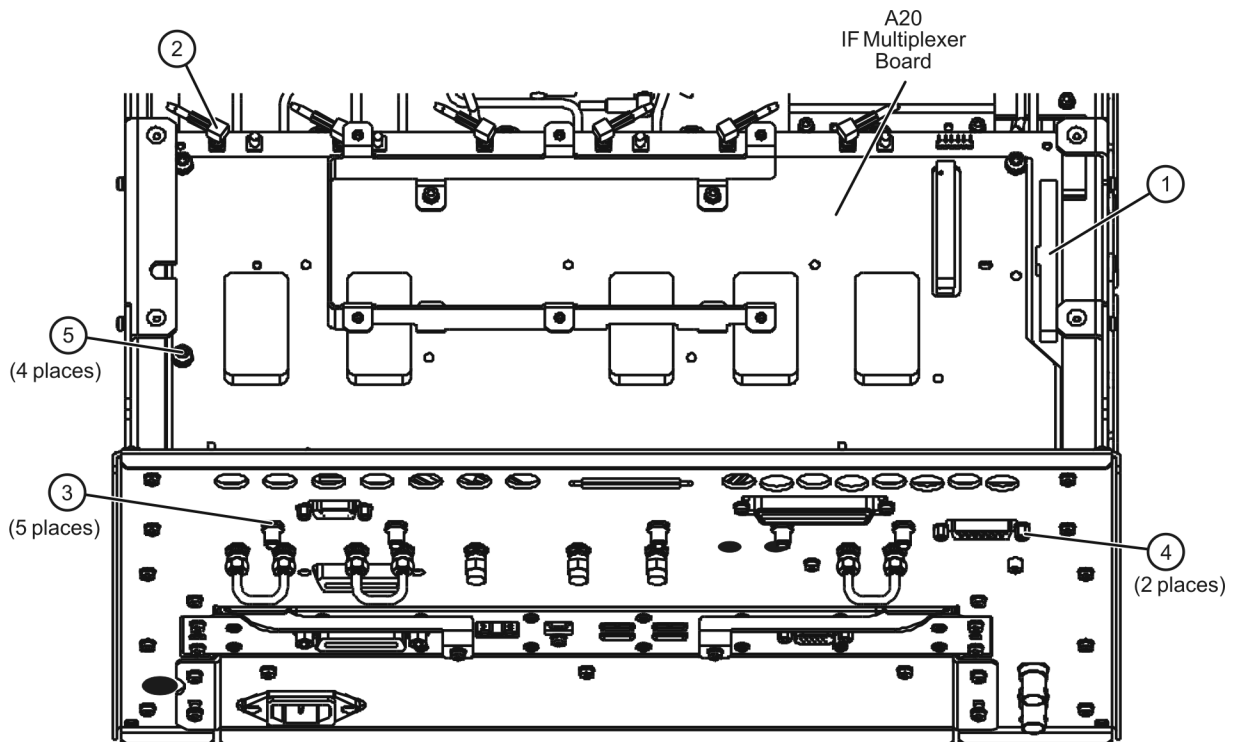

n5242_003_17

Reinstall the A19 Test Set Motherboard

CAUTION Follow instructions carefully when making cable connections, especially wire harness connections. Incorrect connections can destroy components, resulting in additional customer costs.

Refer to [Figure 13](#) for this part of this step of the procedure.

1. Position the A19 test set motherboard in the analyzer and slide it toward the rear of the instrument until the rear panel BNC connectors are completely through the holes in the rear panel.
2. *Loosely* reinstall 10 screws (item ①) in the A19 test set motherboard.
3. Reinstall connector hardware (item ②) on 11 rear panel BNC connectors. Torque hex nuts to 21 in-lbs.
4. Reinstall connector hardware (item ③) on the rear panel TEST SET I/O connector. Torque connector nuts to 6 in-lbs.
5. Torque the 10 screws (item ①) to 9 in-lbs.
6. Reconnect ALL ribbon cables (item ④) and ALL wire harnesses (item ⑤) to the A19 test set motherboard.
7. Connect the mechanical switch control cables to the A19 test set motherboard as follows: A46 to item ⑥ (J101), A47 to item ⑦ (J102), A48 to item ⑧ (J103), A49 to item ⑨ (J104). Refer, if necessary, to [Figure 6](#) on page 13 for locations of A46 through A49.

Figure 13 A19 Test Set Motherboard Reinstallation

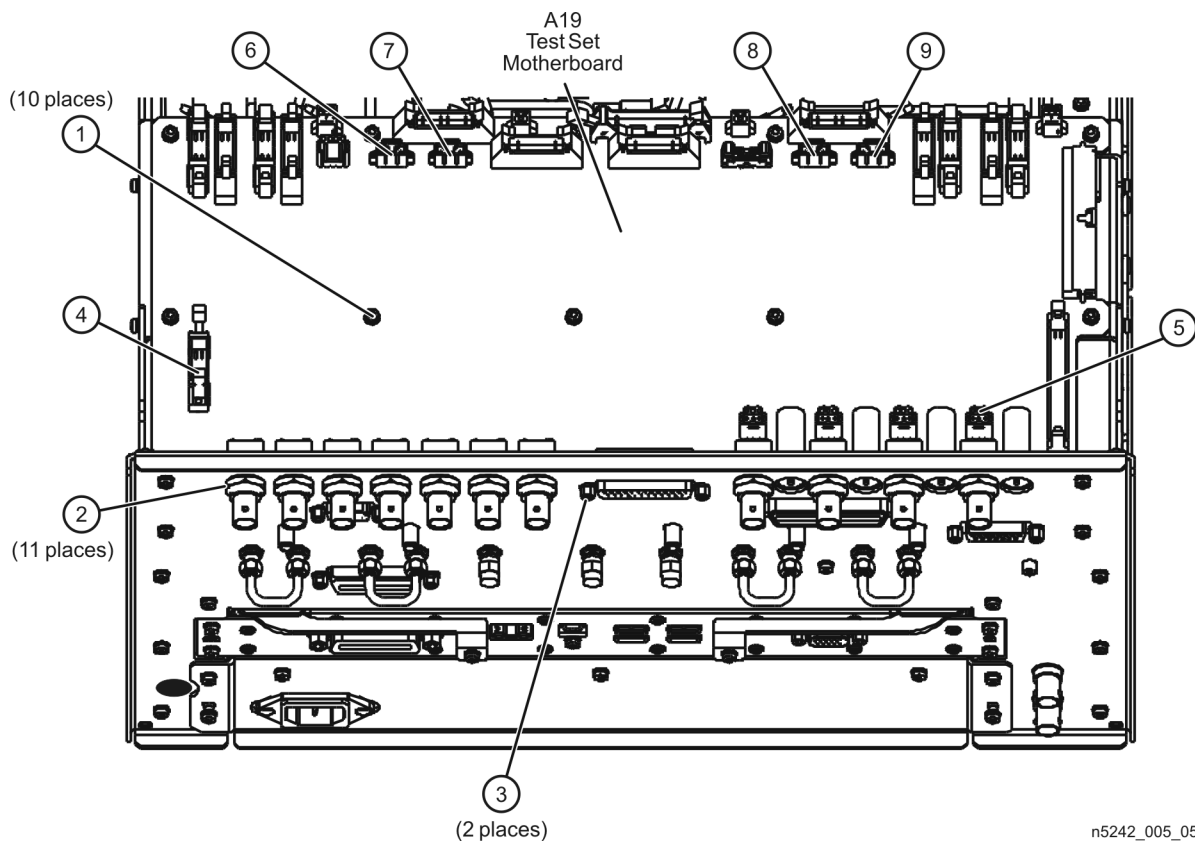

n5242_005_05

Step 11. Reinstall the Front Panel Assembly and Front Panel Jumpers

CAUTION Before installing the front panel assembly onto the analyzer, lift and support the front of the analyzer chassis.

Refer to [Figure 14](#) for this step of the procedure. New parts are listed in [Table 1 on page 4](#).

1. Make sure all of the hex nuts on the front-panel cable connectors have been tightened using a 5/16-in torque wrench set to 21-in lbs.
2. Reconnect the ribbon cable (item ③) to the A1 front panel interface board.
3. Slide the front panel over the front-panel connectors.
4. With a T-10 TORX driver, reinstall the 12 screws (item ②) in the sides of the frame.
5. Reinstall the semirigid jumpers (item ①) on the front panel, and tighten each of the connectors to 10-in lbs.

Figure 14 Front Panel Assembly Reinstallation

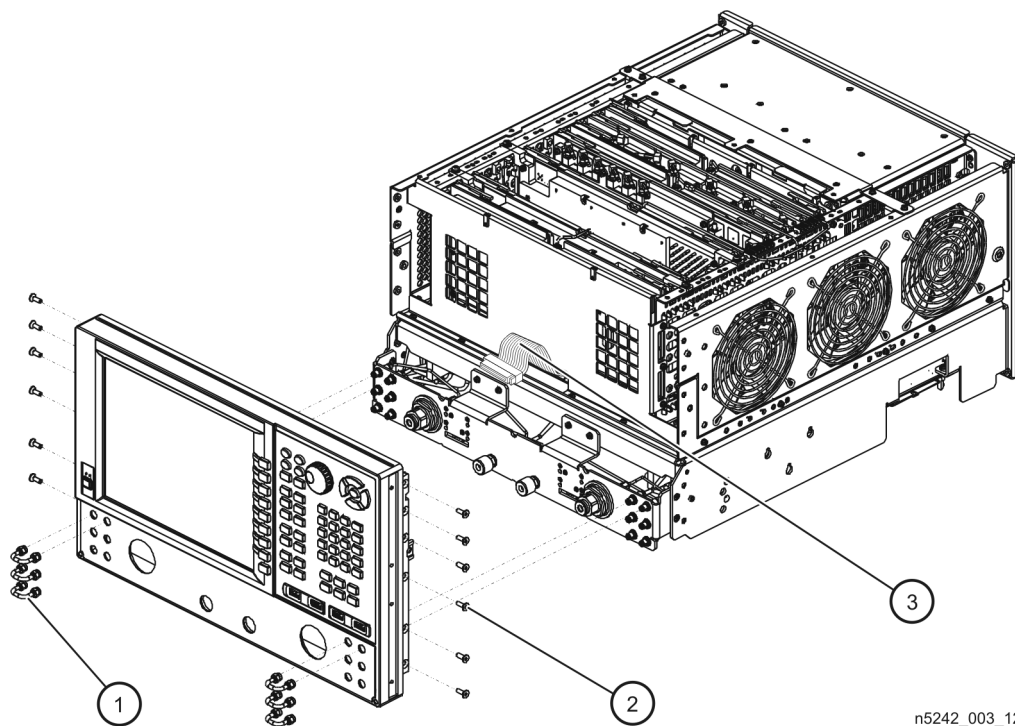

n5242_003_12

Step 12. Position the Cables and Wires to Prevent Pinching

On the top side of the PNA, carefully position the grey flex cables so they can't be pinched between the covers and the rails.

On the bottom side of the PNA, carefully fold or push down the ribbon cables and wires so they can't be pinched between the hardware and the outer cover. Ribbon cables and wires must never be positioned on top of hardware.

Step 13. Reinstall the Outer Cover

CAUTION This procedure is best performed with the analyzer resting on its front handles in the vertical position. *Do not place the analyzer on its front panel without the handles.* This will damage the front panel assemblies.

Refer to **Figure 15** for this step of the procedure.

1. Slide the outer cover over the analyzer frame.
2. Install the four rear panel feet (item ⑤) by installing the center screws (item ⑥) with a T-20 TORX driver.
3. Install the four bottom feet (item ④) onto the bottom of the outer cover then install the foot locks (item ③).
4. Install the strap handles (item ①) by tightening the screws (item ②) on both ends of each strap handle with a T-20 TORX driver.

Figure 15 Outer Cover Reinstallation

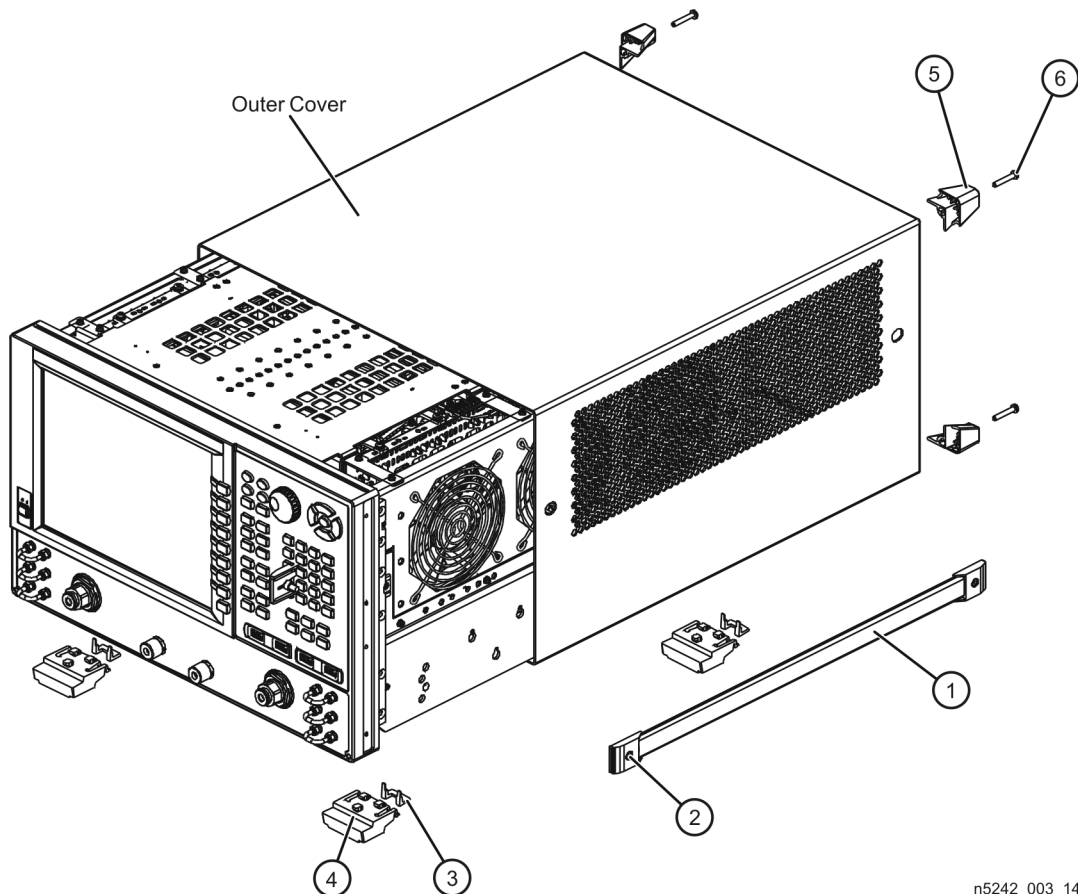

n5242_003_14

Step 14. Enable Option 423

Procedure Requirements

- The analyzer must be powered up and operating to perform this procedure.
- The Network Analyzer program must be running.

Option Enable Procedure

1. To start the option enable utility, press UTILITY **System**, then **Service**, then **Option Enable**. An option enable dialog box will appear.
2. Click the arrow in the **Select Desired Option** box. A list of available options will appear.
3. In the **Select Desired Option** list, click **423 - Combiner & Switches**. Click **Enable**.
4. Click **Yes** in answer to the displayed question in the **Restart Analyzer?** box.
5. When the installation is complete, click **Exit**.

Option Verification Procedure

Once the analyzer has restarted and the Network Analyzer program is again running:

1. On the analyzer's **Help** menu, click **About Network Analyzer**.
2. Verify that "423" is listed after "Options:" in the display. Click **OK**.

NOTE If Option 423 has not been enabled, perform the "Option Enable Procedure" again. If the option is still not enabled, contact Keysight Technologies. Refer to "Getting Assistance from Keysight" on page 3.

Step 15. Perform Post-Upgrade Adjustments and Calibration

Adjustments

The following adjustments must be made due to the hardware changes of the analyzer.

- source adjustment
- receiver adjustment

These adjustments are described in the PNA Service Guide and in the PNA on-line HELP. A list of equipment required to perform these adjustments is also found in the service guide.

To view the Service Guide online, use the following steps:

1. Go to www.keysight.com.
2. In the Search box, enter the model number of your analyzer, N5242A, and click **Search**.
3. Click [Technical Support > Manuals](#).
4. Click [Service Manual](#).
5. Click the service guide title to load the PDF file.
6. When the PDF of the Service Guide is displayed, scroll through the Contents section bookmarks to locate the “Tests & Adjustments” chapter.

After the specified adjustments have been performed, the analyzer should operate and phase lock over its entire frequency range.

Operator’s Check

Perform the Operator’s Check to check the basic functionality of the analyzer. For instructions, refer to the “Tests & Adjustments” chapter of the Service Guide.

If you experience difficulty with the basic functioning of the analyzer, contact Keysight. Refer to [“Contacting Keysight” on page 3](#).

Calibration

Although the analyzer functions, its performance relative to its specifications has not been verified. It is recommended that a full instrument calibration be performed using the analyzer’s internal performance test software. Refer to the analyzer’s service guide for information on this performance test software.

Step 16. Prepare the PNA for the User

1. If necessary, reinstall front jumper cables.
2. Install the cable guards, pushing them over the front jumper cables until the cushioning material touches the front panel of the PNA.
3. Install the dust caps on the test ports.
4. Clean the analyzer, as needed, using a damp cloth.

This information is subject to change without notice.

© Keysight Technologies 2007 – 2014

August 2014



N5242-90005
www.keysight.com