

Keysight Second Source, Combiner, and Mechanical Switches Upgrade Kit

To Upgrade PNA-X N5241A or N5242A Option 219 to
Option 224

For Analyzers with Serial Numbers Prefixed MY/SG/
US5201 and Above

Upgrade Kit Order Numbers: N5241AU-932 and
N5242AU- 932

Keysight Kit Number: N5242-60114

NOTICE: This document contains references to Agilent Technologies. Agilent's former Test and Measurement business has become Keysight Technologies. For more information, go to www.keysight.com.



WARRANTY STATEMENT

THE MATERIAL CONTAINED IN THIS DOCUMENT IS PROVIDED "AS IS," AND IS SUBJECT TO BEING CHANGED, WITHOUT NOTICE, IN FUTURE EDITIONS. FURTHER, TO THE MAXIMUM EXTENT PERMITTED BY APPLICABLE LAW, KEYSIGHT DISCLAIMS ALL WARRANTIES, EITHER EXPRESS OR IMPLIED WITH REGARD TO THIS MANUAL AND ANY INFORMATION CONTAINED HEREIN, INCLUDING BUT NOT LIMITED TO THE IMPLIED WARRANTIES OF MERCHANTABILITY AND FITNESS FOR A PARTICULAR PURPOSE. KEYSIGHT SHALL NOT BE LIABLE FOR ERRORS OR FOR INCIDENTAL OR CONSEQUENTIAL DAMAGES IN CONNECTION WITH THE FURNISHING, USE, OR PERFORMANCE OF THIS DOCUMENT OR ANY INFORMATION CONTAINED HEREIN. SHOULD KEYSIGHT AND THE USER HAVE A SEPARATE WRITTEN AGREEMENT WITH WARRANTY TERMS COVERING THE MATERIAL IN THIS DOCUMENT THAT CONFLICT WITH THESE TERMS, THE WARRANTY TERMS IN THE SEPARATE AGREEMENT WILL CONTROL.

DFARS/Restricted Rights Notice

If software is for use in the performance of a U.S. Government prime contract or subcontract, Software is delivered and licensed as "Commercial computer software" as defined in DFAR 252.227-7014 (June 1995), or as a "commercial item" as defined in FAR 2.101(a) or as "Restricted computer software" as defined in FAR 52.227-19 (June 1987) or any equivalent agency regulation or contract clause. Use, duplication or disclosure of Software is subject to Keysight Technologies' standard commercial license terms, and non-DOD Departments and Agencies of the U.S. Government will receive no greater than Restricted Rights as defined in FAR 52.227-19(c)(1-2) (June 1987). U.S. Government users will receive no greater than Limited Rights as defined in FAR 52.227-14 (June 1987) or DFAR 252.227-7015 (b)(2) (November 1995), as applicable in any technical data.

Safety Notes

The following safety notes are used throughout this document. Familiarize yourself with each of these notes and its meaning before performing any of the procedures in this document.

WARNING **Warning denotes a hazard. It calls attention to a procedure which, if not correctly performed or adhered to, could result in injury or loss of life. Do not proceed beyond a warning note until the indicated conditions are fully understood and met.**

CAUTION Caution denotes a hazard. It calls attention to a procedure that, if not correctly performed or adhered to, could result in damage to or destruction of the instrument. Do not proceed beyond a caution sign until the indicated conditions are fully understood and met.

Description of the Upgrade

This upgrade converts your Option 219 2-port analyzer (with configurable test set, extended power range, and bias tees) to an Option 224 analyzer by adding:

- a second source
- source outputs routed to the front panel
- source outputs routed to the rear panel
- a mechanical switch to each source port channel
- a source combiner to the port 1 channel
- rear-panel test set inputs

Getting Assistance from Keysight

By internet, phone, or fax, get assistance with all your test and measurement needs.

Contacting Keysight

Assistance with test and measurements needs and information on finding a local Keysight office are available on the Web at:

<http://www.keysight.com/find/assist>

If you do not have access to the Internet, please contact your Keysight field engineer.

NOTE In any correspondence or telephone conversation, refer to the Keysight product by its model number and full serial number. With this information, the Keysight representative can determine whether your product is still within its warranty period.

If You Have Problems With the Upgrade Kit Contents

Keysight stands behind the quality of the upgrade kit contents. If you have problems with any item in the kit, email Keysight Component Test Division (CTD) Support at support_ctd-soco@keysight.com, or telephone the CTD Hotline at (707) 577-6802 and leave a voice mail message. Please include details of the problem.

Getting Prepared

CAUTION The PNA contains extremely sensitive components that can be ruined if mishandled. Follow instructions carefully when making cable connections, especially wire harness connections.

The person performing the work accepts responsibility for the full cost of the repair or replacement of damaged components.

To successfully install this upgrade kit, you will need the following:

- A license key - refer to “[License Key Redemption](#)” below.
- A PDF copy or a paper copy of the PNA Service Guide - refer to “[Downloading the Online PNA Service Guide](#)” below.
- An ESD-safe work area - refer to “[Protecting Your Workspace from Electrostatic Discharge](#)” below.
- Correct tools - refer to “[Tools Required for the Installation](#)” on page 5.
- Enough time - refer to “[About Installing the Upgrade](#)” on page 6.
- Test equipment for the post-upgrade adjustments. To view the equipment list, click the Chapter 3 bookmark “[Tests and Adjustments](#)” in the PDF Service Guide¹.

License Key Redemption

NOTE The enclosed Option Entitlement Certificate is a receipt, verifying that you have purchased a licensed option for the PNA of your choice. You must now use a Keysight Web page to request a license key for the instrument that will receive the option.

To enable the option product, you must request a license key from: <http://www.keysight.com/find/softwarelicense>. To complete the request, you will need to gather the following information:

- From the certificate
 - Order number
 - Certificate number
- From your instrument
 - Model number
 - Serial number
 - Host ID

The instrument information is available on the network analyzer – on the analyzer’s **Help** menu, click **About Network Analyzer**.

If you provide an email address, Keysight will promptly email your license key. Otherwise, you will receive your license key via postal mail.

1. See “[Downloading the Online PNA Service Guide](#)” on page 5.

Downloading the Online PNA Service Guide

To view the online Service Guide for your PNA model number, use the following steps:

1. Go to www.keysight.com.
2. In the Search box, enter the model number of the analyzer (Ex: N5242A) and click **Search**.
3. Click **Technical Support > Manuals**.
4. Click **Service Manual**.
5. Click the service guide title to download the PDF file.
6. When the PDF of the Service Guide is displayed, scroll through the Contents section bookmarks to locate the information needed.

Protecting Your Workspace from Electrostatic Discharge

- For information, click on the Chapter 1 bookmark, “Electrostatic Discharge Protection” in the PDF Service Guide¹.

ESD Equipment Required for the Installation

Description	Keysight Part Number
ESD grounding wrist strap	9300-1367
5-ft grounding cord for wrist strap	9300-0980
2 x 4 ft conductive table mat and 15-ft grounding wire	9300-0797
ESD heel strap (for use with conductive floors)	9300-1308

Tools Required for the Installation

Description	Qty	Part Number
T-10 TORX driver (set to 9 in-lbs)	1	N/A
T-20 TORX driver (set to 21 in-lbs)	1	N/A
5/16-in torque wrench (set to 10 in-lbs)	1	N/A
5/16-in torque wrench (set to 21 in-lbs)	1	N/A

CAUTION Use a 5/16-in torque wrench set to 10 in-lbs on all cable connections except the front and rear panel bulkhead connectors. Torque these connections to 21 in-lb.

1. See “[Downloading the Online PNA Service Guide](#)” on page 5.

About Installing the Upgrade

Products affected	N5241A and N5242A Option 219
Installation to be performed by	Keysight service center or personnel qualified by Keysight
Estimated installation time	5.0 hours
Estimated adjustment time	0.5 hours
Estimated full instrument calibration time	4.5 hours

Items Included in the Upgrade Kit

Check the contents of your kit against the following list. If any part is missing or damaged, contact Keysight Technologies. Refer to [“Getting Assistance from Keysight” on page 3](#).

Table 1 Contents of Upgrade Kit N5242-60114^a

Ref Desig.	Description	Qty	Part Number
	Installation note (this document)	1	N5242-90114
A8	26.5 GHz source 2 board	1	5087-7307
A13	13.5 GHz source 2 synthesizer board	1	N5240-60074 Was N5242-60150
A46	Port 1 mechanical switch	3	N1811-60028
A47	SRC 2 OUT mechanical switch		
A49	Port 2 mechanical switch		
A50	Combiner (bridge)	1	5087-7757
--	Switch bracket	3	N5242-00009
--	Machine screw, M2.5 x 20, pan head (to attach mechanical switch to switch bracket)	6	0515-1992
--	Machine screw, M3.0 x 20, pan head (to attach combiner to switch bracket)	2	0515-1410
--	Machine screw, M3.0 x 6, pan head (to attach switch bracket to analyzer)	6	0515-0430
--	Bulkhead connector assembly (for rear panel)	7	1250-3805
--	Termination, 50 ohm (for rear-panel PORT 3 SW TSET IN (J7))	1	1810-0118
--	Bulkhead connector (front-panel SRC 2 OUT 1 and SRC 2 OUT 2)	2	08673-60040
--	Washer (for bulkhead connector)	2	2190-0016
--	Hex nut (for bulkhead connector)	2	2950-0001
--	Lower front panel overlay (Option 224)	1	N5242-80002
W2	RF cable, A13 13.5 GHz source 2 synthesizer J1207 to A8 26.5 GHz source 2 P1	1	N5222-20090
W5	RF cable, A8 26.5 GHz source 2 to W101	1	N5222-20062

Table 1 Contents of Upgrade Kit N5242-60114^a

Ref Desig.	Description	Qty	Part Number
W7	RF cable, A8 26.5 GHz source 2 to W68	1	N5222-20063
W25	RF cable, front-panel REF 2 SOURCE OUT to A28 port 2 bridge	1	N5222-20038
W57	RF flex cable, A10 frequency reference board J7 to A13 13.5 GHz source 2 synthesizer J5	1	N5242-60030
W67	RF cable, A47 SRC 2 mechanical switch to front-panel SRC 2 OUT 1	1	N5242-20290
W68	RF cable, W7 (from A8 26.5 GHz source 2) to front-panel SRC 2 OUT 2	1	N5242-20291
W95	RF cable, W3 (from A5 26.5 GHz source 1) to A46 port 1 mechanical switch	1	N5242-20269
W96	RF cable, A46 port 1 mechanical switch to A25 test port 1 bridge	1	N5242-20264
W97	RF cable, A46 port 1 mechanical switch to rear-panel PORT 1 SW SRC OUT (J11)	1	N5242-20287
W98	RF cable, rear-panel PORT 1 COMB THRU IN (J10) to A50 combiner	1	N5242-20288
W99	RF cable, rear-panel PORT 1 COMB ARM IN (J9) to A50 combiner	1	N5242-20289
W100	RF cable, A50 combiner to A46 port 1 mechanical switch	1	N5242-20265
W101	RF cable, W5 (from A8 26.5 GHz source 2) to A47 SRC 2 mechanical switch	1	N5242-20266
W103	RF cable, A47 SRC 2 mechanical switch to rear-panel SRC 2 SW SRC OUT (J8)	1	N5242-20282
W104	RF cable, rear-panel PORT 3 SW TSET IN (J7) to A47 SRC 2 mechanical switch	1	N5242-20281
W109	RF cable, W9 (from A5 26.5 GHz source 1) to A49 port 2 mechanical switch	1	N5242-20268
W110	RF cable, A49 port 2 mechanical switch to A28 test port 2 bridge	1	N5242-20262
W111	RF cable, A49 port 2 mechanical switch to rear-panel PORT 2 SW SRC OUT (J2)	1	N5242-20285
W112	RF cable, rear-panel PORT 2 SW TSET IN (J1) to A49 port 2 mechanical switch	1	N5242-20286
W113	Rear panel jumper	3	N5222-20091
W154	RF cable, front panel REF 2 RCVR R2 IN to A23 mixer brick (R2)	1	N5242-20308

a. In addition to the upgrade kit, the shipment includes an Option Entitlement Certificate. Refer to [“License Key Redemption” on page 4](#) for important information about this certificate.

NOTE Extra quantities of items such as protective plastic caps, screws, cable ties, and cable clamps may be included in this upgrade kit. It is normal for some of these items to remain unused after the upgrade is completed.

Installation Procedure for the Upgrade

The network analyzer must be in proper working condition prior to installing this option. Any necessary repairs must be made before proceeding with this installation.

WARNING **This installation requires the removal of the analyzer's protective outer covers. The analyzer must be powered down and disconnected from the mains supply before performing this procedure.**

Overview of the Installation Procedure

- Step 1. Obtain a Keyword and Verify the Information.
- Step 2. Remove the Outer Cover.
- Step 3. Remove the Inner Cover.
- Step 4. Remove the Front Panel Assembly.
- Step 5. Remove the Existing Test Set Cables.
- Step 6. Assemble the Mechanical Switches.
- Step 7. Install the Mechanical Switches.
- Step 8. Install the Second Source Boards.
- Step 9. Install the Source 2 Front Panel Connectors.
- Step 10. Remove the A19 Test Set Motherboard and the A20 IF Multiplexer Board.
- Step 11. Install the Bulkhead Connectors and Jumpers on the Rear Panel.
- Step 12. Install the New Test Set Cables.
- Step 13. Reinstall the A20 IF Multiplexer Board and the A19 Test Set Motherboard.
- Step 14. Replace the Lower Front Panel Overlay.
- Step 15. Reinstall the Front Panel Assembly and Front Panel Jumpers.
- Step 16. Position the Cables and Wires to Prevent Pinching.
- Step 17. Reinstall the Inner Cover.
- Step 18. Reinstall the Outer Cover.
- Step 19. Enable Option 224.
- Step 20. Perform Post-Upgrade Adjustments and Calibration.
- Step 21. Prepare the PNA for the User.

Step 1. Obtain a Keyword and Verify the Information

Follow the instructions on the Option Entitlement Certificate supplied to obtain a license key for installation of this upgrade. Refer to [“License Key Redemption” on page 4](#).

Verify that the model number, serial number, and option number information on the license key match those of the instrument on which this upgrade will be installed.

If the model number, serial number, or option number do not match those on your license key, you will not be able to install the option. If this is the case, contact Keysight for assistance before beginning the installation of this upgrade. Refer to [“Contacting Keysight” on page 3](#).

Once the license key has been received and the information verified, you can proceed with the installation at step 2.

Step 2. Remove the Outer Cover

CAUTION This procedure is best performed with the analyzer resting on its front handles in the vertical position. *Do not place the analyzer on its front panel without the handles.* This will damage the front panel assemblies.

Refer to [Figure 2](#) for this step of the procedure.

1. Disconnect the power cord (if it has not already been disconnected).
2. Remove the strap handles (item ①) by loosening the screws (item ②), with a T-20 TORX driver, on both ends until the handle is free of the analyzer.
3. Remove the foot locks (item ③) from the four bottom feet (item ④) and then remove the four bottom feet from the outer cover.
4. Remove the four rear panel feet (item ⑤) by removing the center screws (item ⑥) with a T-20 TORX driver.
5. Slide the outer cover toward the rear of the analyzer and remove it.

Figure 2 Outer Cover Removal

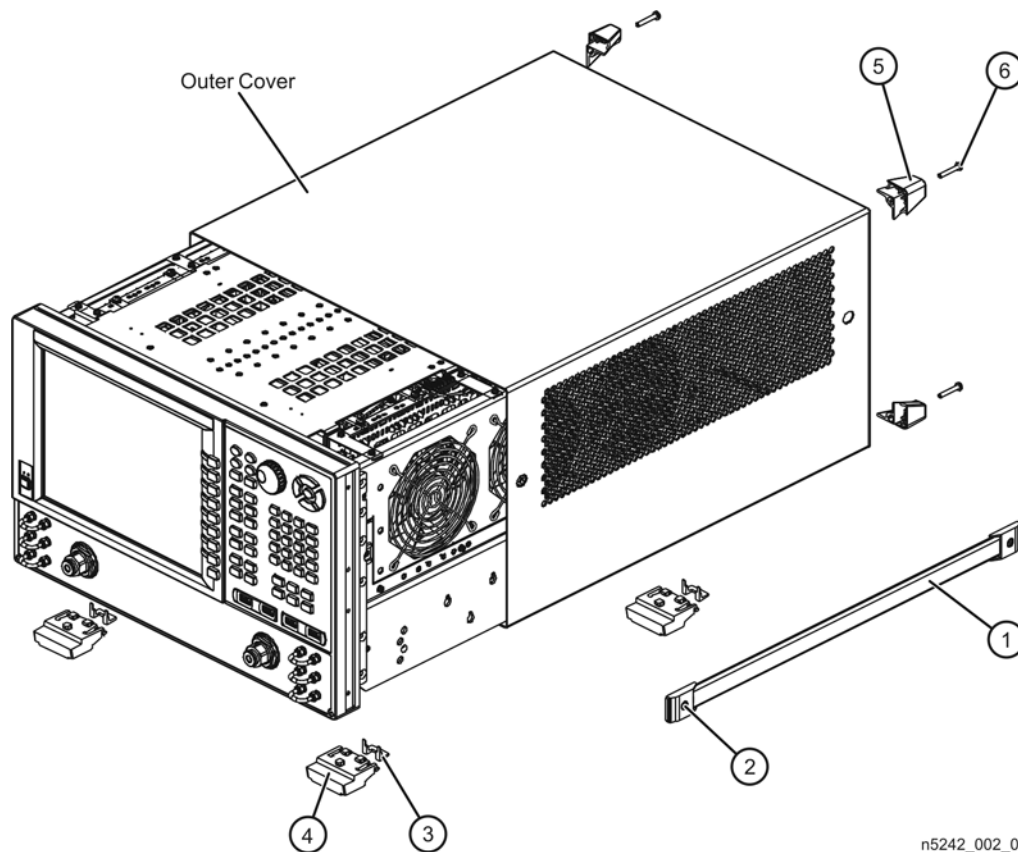

n5242_002_01

Step 3. Remove the Inner Cover

Refer to [Figure 3](#) for this step of the procedure.

Figure 3 Inner Cover Removal

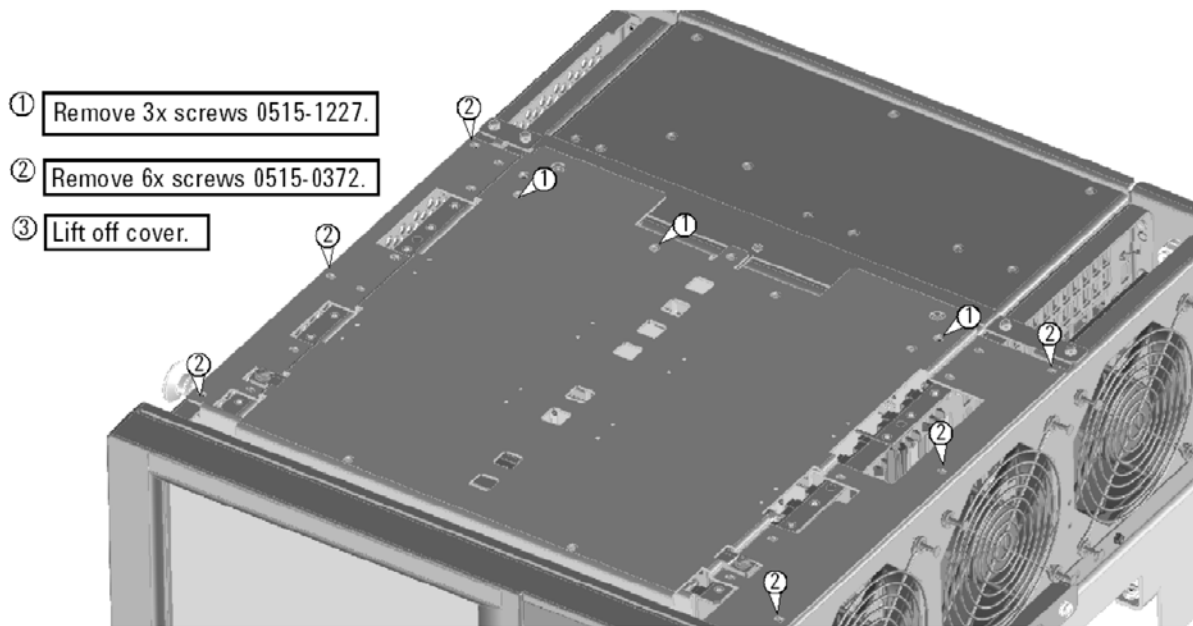

n5242_003_02

Step 4. Remove the Front Panel Assembly

Refer to [Figure 4](#) for this step of the procedure.

1. With a 5/16-in wrench, remove all front panel jumpers (item ①).
2. With a T-10 TORX driver, remove the screws (item ②) from the sides of the frame.

CAUTION Before removing the front panel from the analyzer, lift and support the front of the analyzer chassis.

3. Slide the front panel over the test port connectors.
4. Disconnect the front panel interface ribbon cable (item ③). The front panel is now free from the analyzer.

Figure 4 Front Panel Assembly Removal

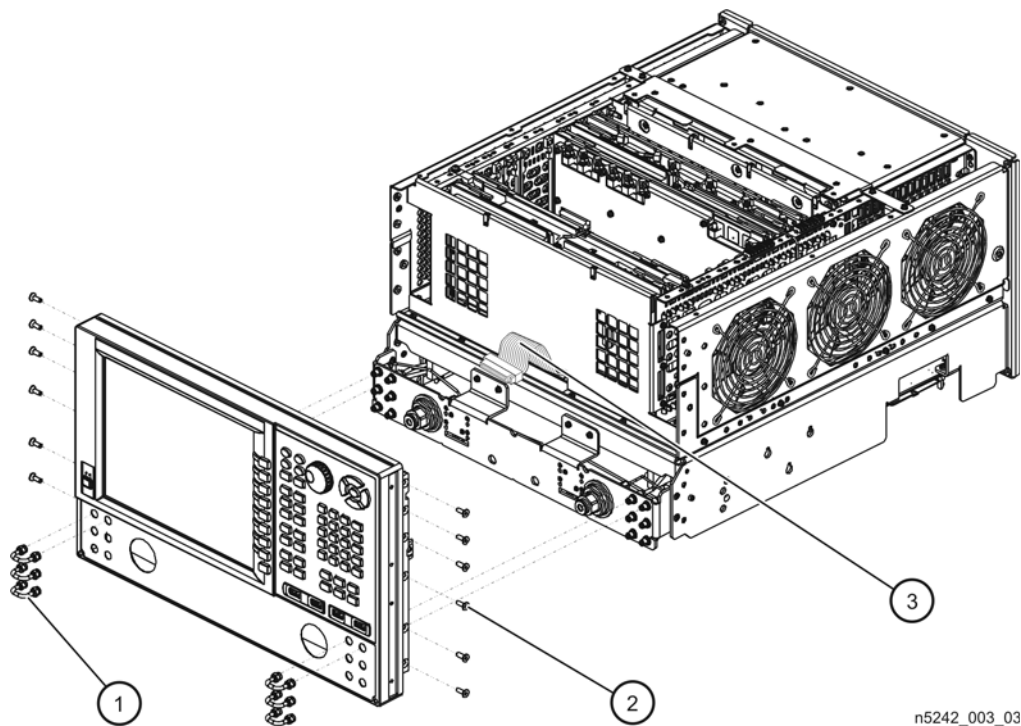

n5242_003_03

Step 5. Remove the Existing Test Set Cables

NOTE Leave the gray flexible cables, the wire harnesses, and the ribbon cables connected where possible. **Any that are removed should be labeled for reconnection later.**

CAUTION Be careful not to damage the center pins of the semirigid cables. Some flexing of the cables may be necessary but do not over-bend them.

Refer to [Figure 5](#) for this step of the procedure.

1. Place the analyzer bottom-side up on a flat surface.
2. Remove the following cables in the order listed:
 - W4 A25 port 1 bridge to W3 (from A5 26.5 GHz source 1 board OUT 1)
 - W10 A28 port 2 bridge to W9 (from A5 26.5 GHz source 1 board OUT 2)
 - W40 Front-panel REF 2 RCVR R2 IN to A23 mixer brick (R2)

For analyzers with serial numbers prefixed MY/SG/US5310 and below:

- W25 A28 port 2 bridge to front-panel REF 2 SOURCE OUT

Figure 5 Existing Test Set Cables Removal

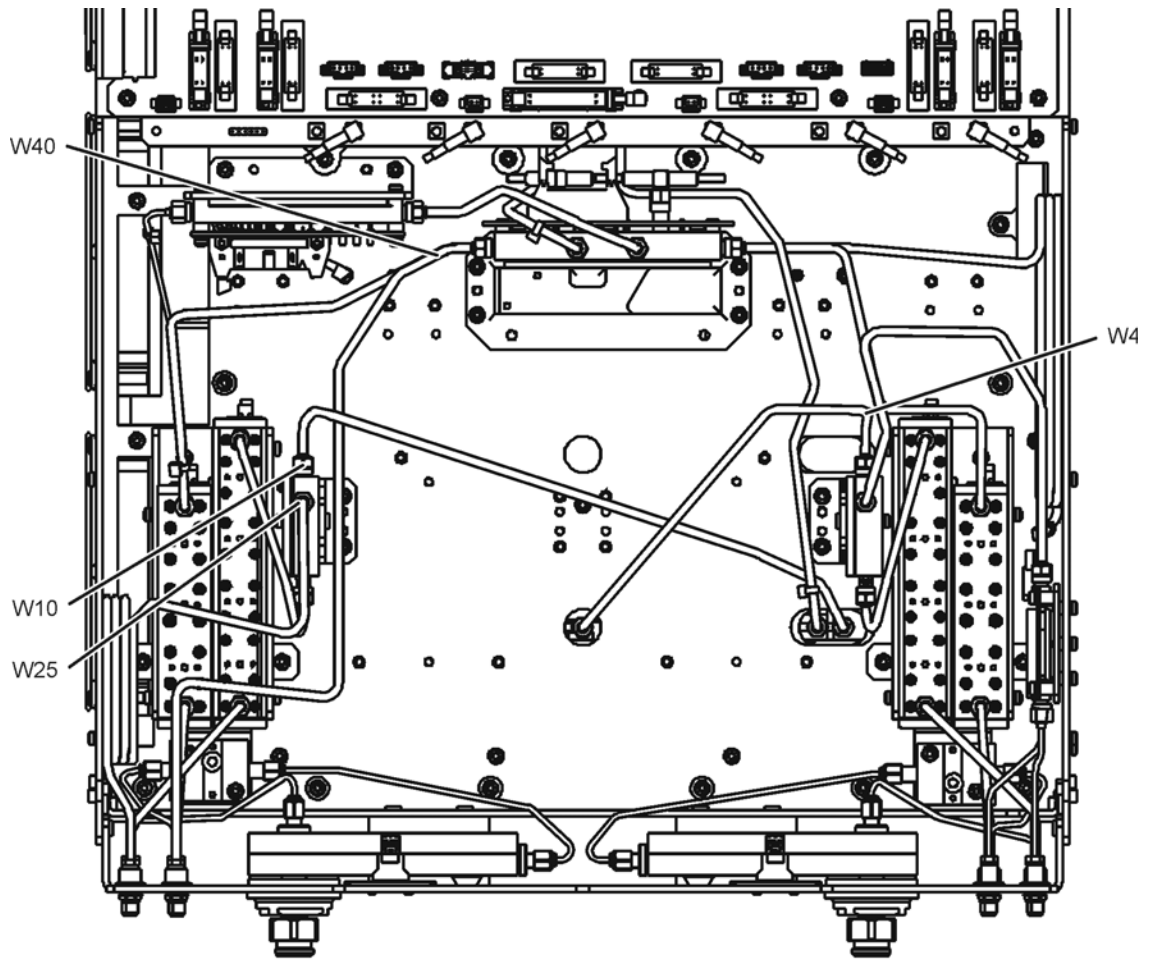

n5242_003_04

Step 6. Assemble the Mechanical Switches

Refer to [Figure 6](#) for this step of the procedure. New parts are listed in [Table 1 on page 6](#).

1. Position each mechanical switch on a switch bracket as shown.
2. Secure each switch to its bracket using two screws (item ①, 0515-1992) for each. Make sure that the switches are oriented as shown.
3. Position the A50 combiner on one of the switch brackets as shown. This will be the bracket with the A46 port 1 mechanical switch.
4. Secure the A50 combiner to the bracket using two screws (item ②, 0515-1410). Make sure that the A50 combiner is oriented as shown.

Figure 6 Mechanical Switches Assembly

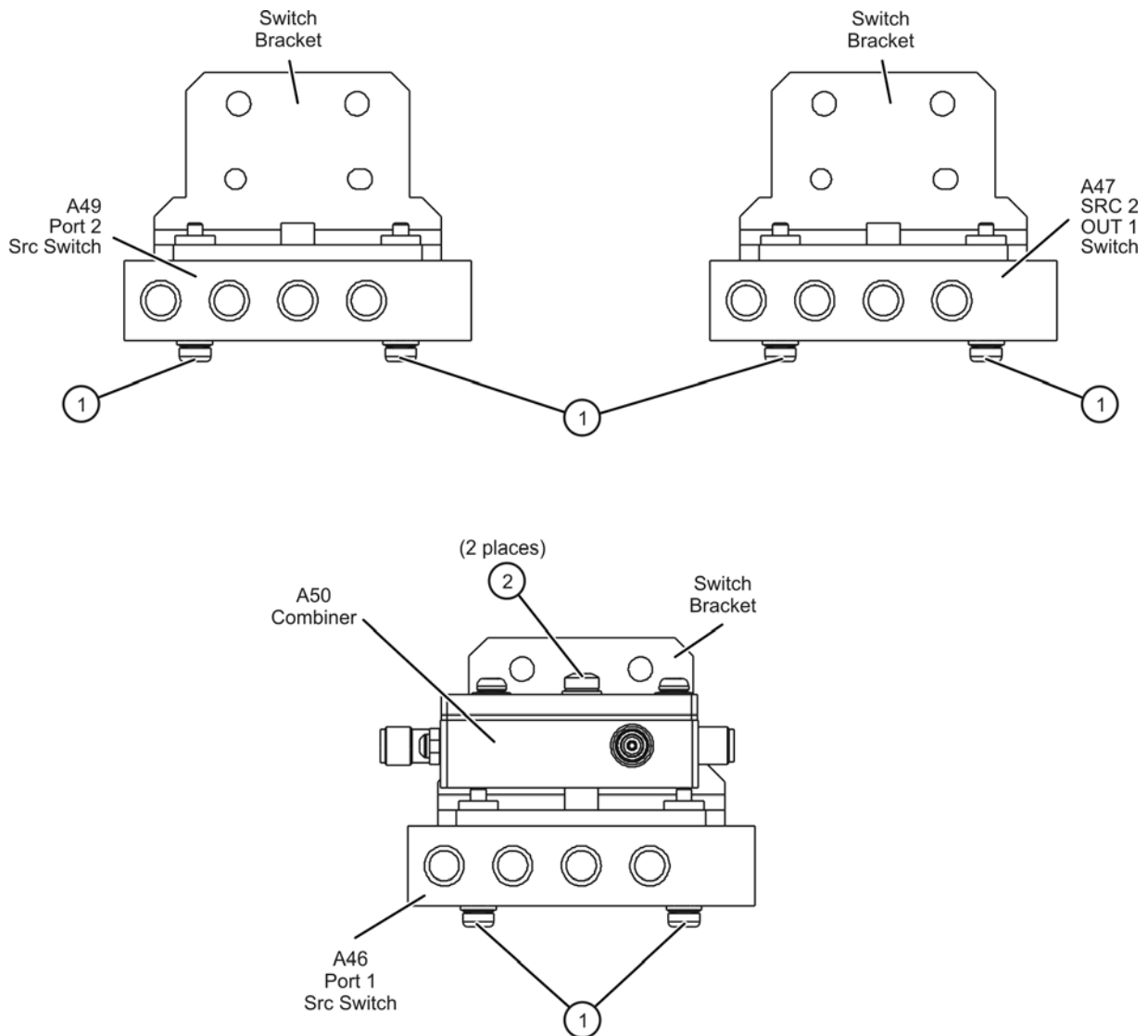

n5242_003_05

Step 7. Install the Mechanical Switches

Refer to [Figure 7](#) for this step of the procedure. New parts are listed in [Table 1](#) on page 6.

1. Position the switch brackets (with the switches and combiner attached) in the analyzer as shown. Make sure that the switch bracket with the A50 combiner is in the location shown.
2. Secure the switch brackets to the analyzer test set deck using two screws (item ①, 0515-0430) each.

Figure 7 Mechanical Switches Installation into the Analyzer

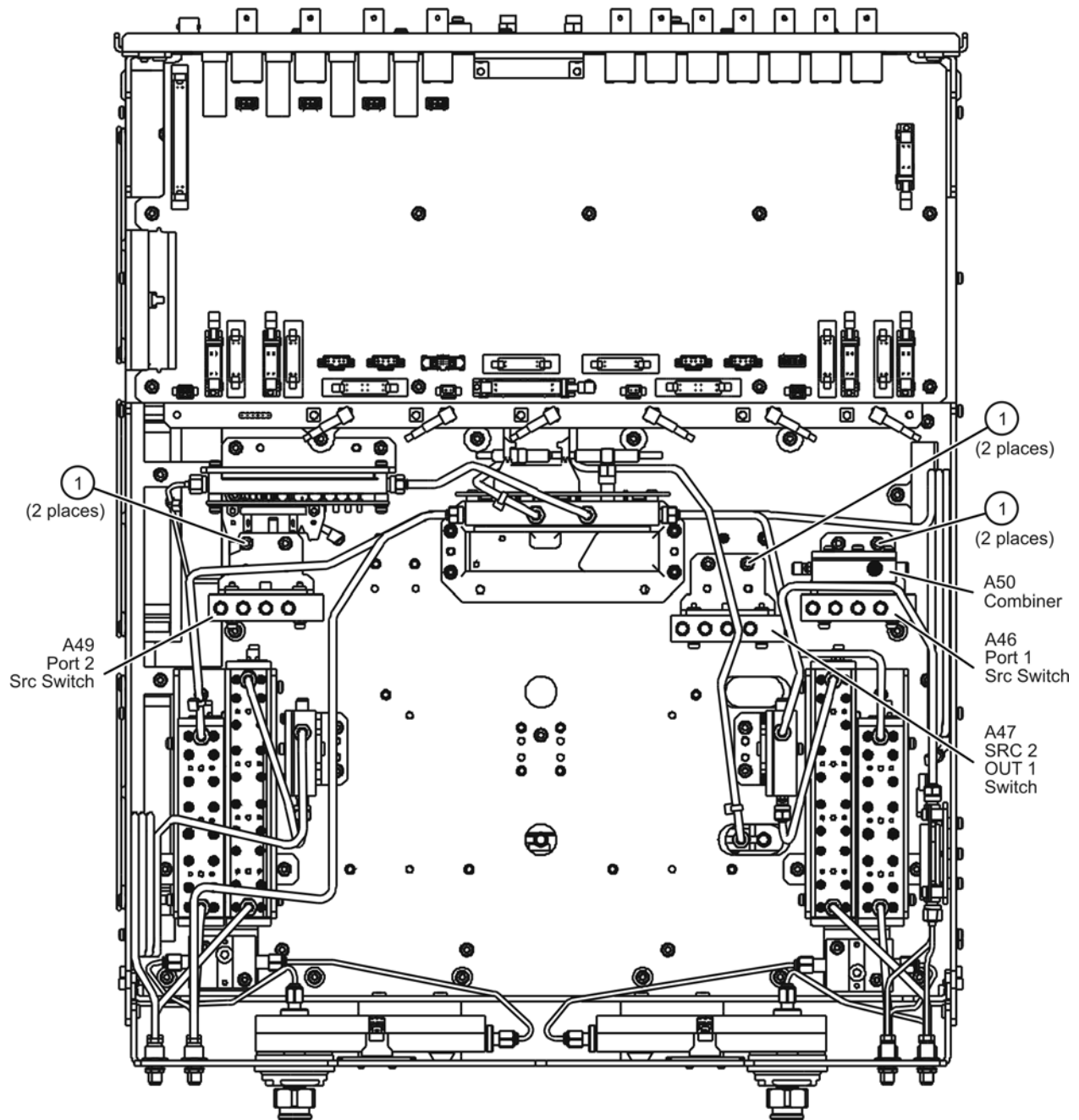

n5242_003_06

Step 8. Install the Second Source Boards

Part 1: Install Cables on Second Source Boards

Refer to [Figure 8](#) and [Figure 9](#) for this step of the procedure. New parts are listed in [Table 1 on page 6](#).

1. Attach gray flex cable W57 to the J5 connector on the A13 13.5 GHz synthesizer board as shown. The other end of the cable will be connected to the A10 frequency reference board later. Unlike the board shown in the graphic below, the board included in this kit has tabs that connect to the chassis side rails with screws.

Figure 8 Cable Connections to the Second Source Boards, Part 1a

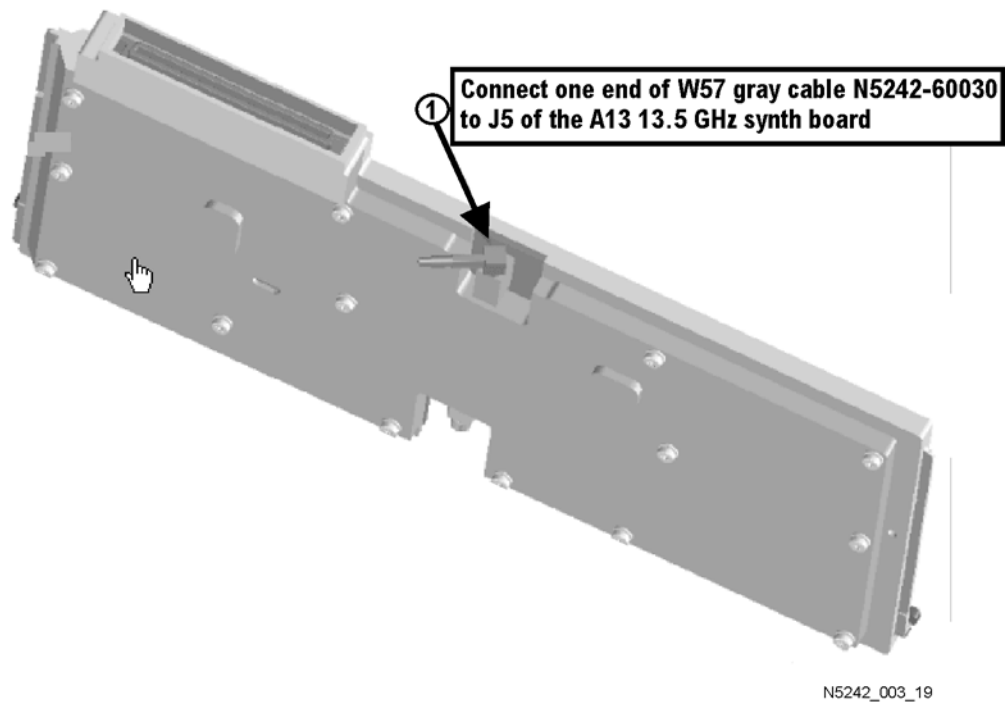

2. Attach semi-rigid cables W5 and W7 to the A8 26.5 GHz source 2 board as shown. Make sure that both cables are parallel to the A8 26.5 GHz source board as shown in the END VIEW. Cable W5 is the longer of the two cables.
3. Use a 5/16-in torque wrench set to 10 in-lbs to tighten the semi-rigid cable connectors.

Figure 9 Cable Connections to the Second Source Boards, Part 1b

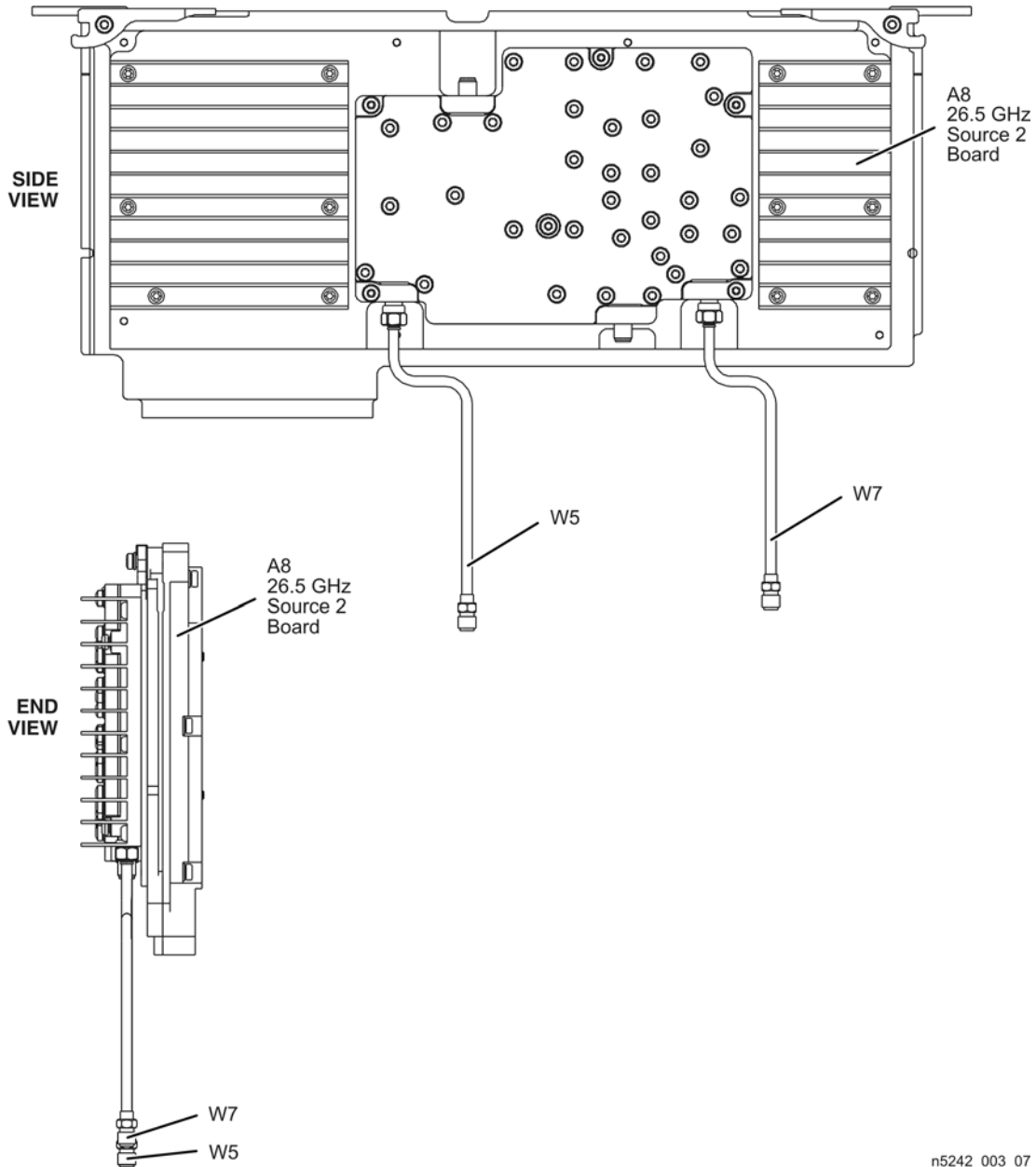

n5242_003_07

Part 2: Install the Second Source Boards into the Analyzer

Refer to [Figure 10](#) for this part of this step of the procedure. New parts are listed in [Table 1 on page 6](#).

1. Install the A8 26.5 GHz source 2 board and the A13 13.5 GHz source 2 synthesizer board in the analyzer as shown.
2. Secure both boards with two screws (item ①) — one on each side of each board.
3. Connect the other end of gray flex cable W57 on the A13 13.5 GHz synthesizer board to the J7 connector on the A10 frequency reference board as shown.
4. Connect cable W2 between the A8 26.5 GHz source 2 board and the A13 13.5 GHz source 2 synthesizer board as shown. Tighten the cable connectors to 10 in-lbs using a 5/16-in torque wrench.

Figure 10 Second Source Boards Installation, Part 2

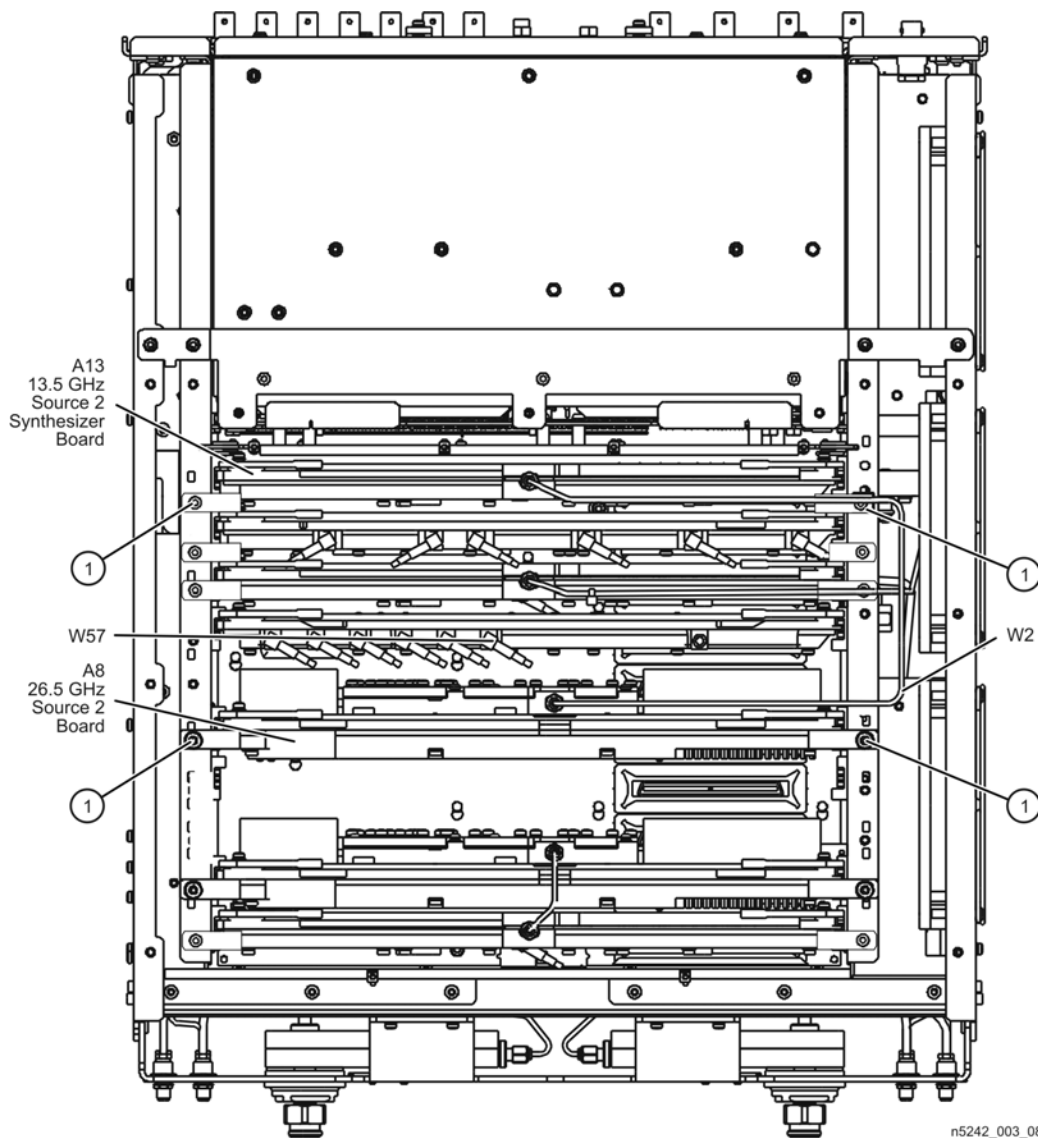

Step 9. Install the Source 2 Front Panel Connectors

Refer to [Figure 11](#) for this step of the procedure. New parts are listed in [Table 1 on page 6](#).

1. Insert two bulkhead connectors (item ①) through the holes in the test set deck front panel as shown.
2. Secure the bulkhead connectors with two lock washers (item ②) and two hex nuts (item ③) as shown.
3. Torque the hex nuts to 21 in-lbs.

Figure 11 Source 2 Front Panel Connectors Installation

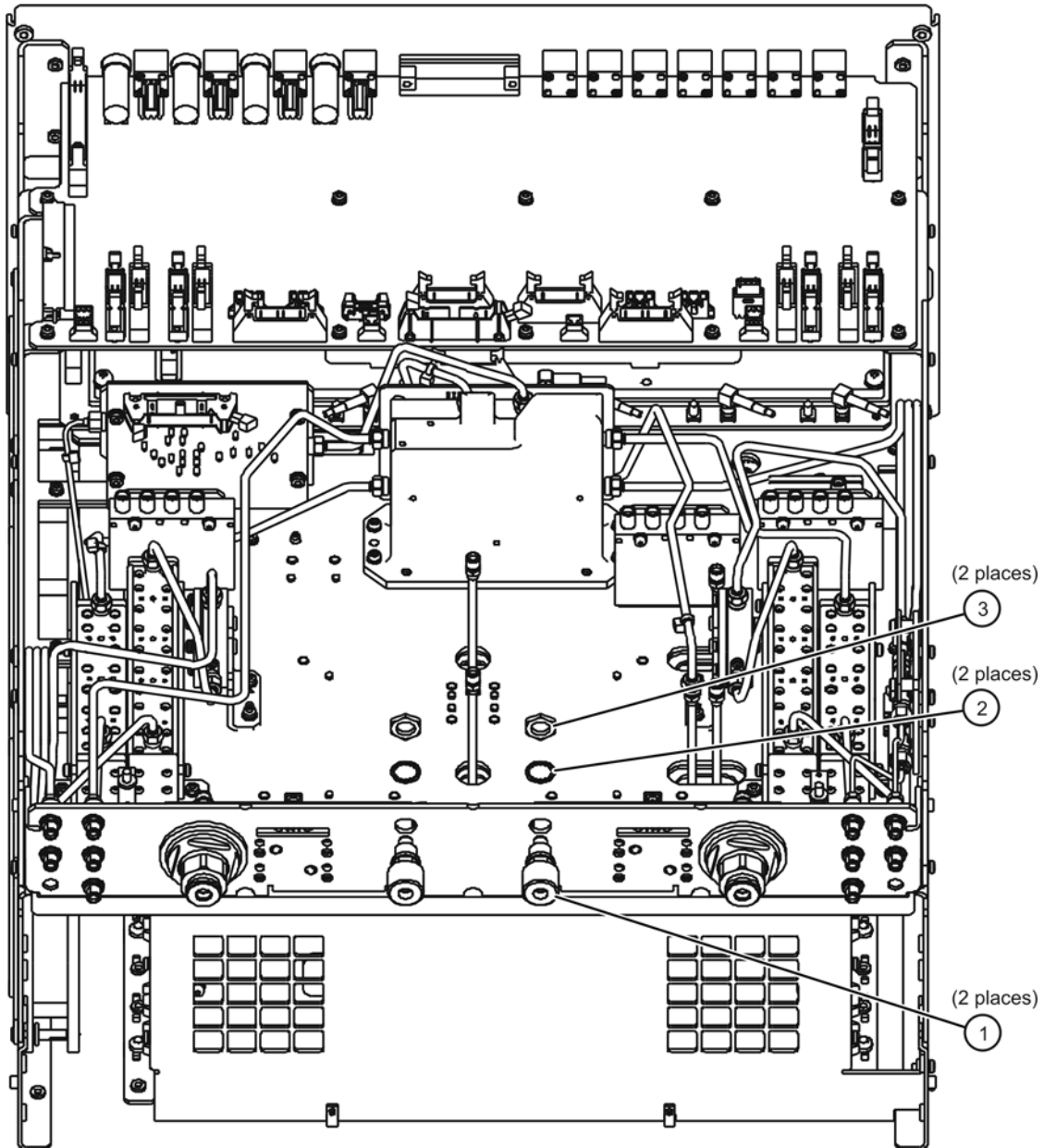

n5242_003_09

Step 10. Remove the A19 Test Set Motherboard and the A20 IF Multiplexer Board

Remove the A19 Test Set Motherboard

Refer to [Figure 12](#) for this part of this step of the procedure.

1. Disconnect ALL ribbon cables (item ①) and ALL wire harnesses (item ②) from the A19 test set motherboard. Make sure they are labeled for re-connection later.
2. Remove connector hardware (item ③) from 11 rear panel BNC connectors.
3. Remove connector hardware (item ④) from the rear panel TEST SET I/O connector.
4. Remove 10 screws (item ⑤) from the A19 test set motherboard.
5. Slide the A19 test set motherboard toward the front of the instrument until the rear panel BNC connectors are free of the rear panel, then lift the motherboard and remove it from the analyzer.

Figure 12 A19 Test Set Motherboard Removal

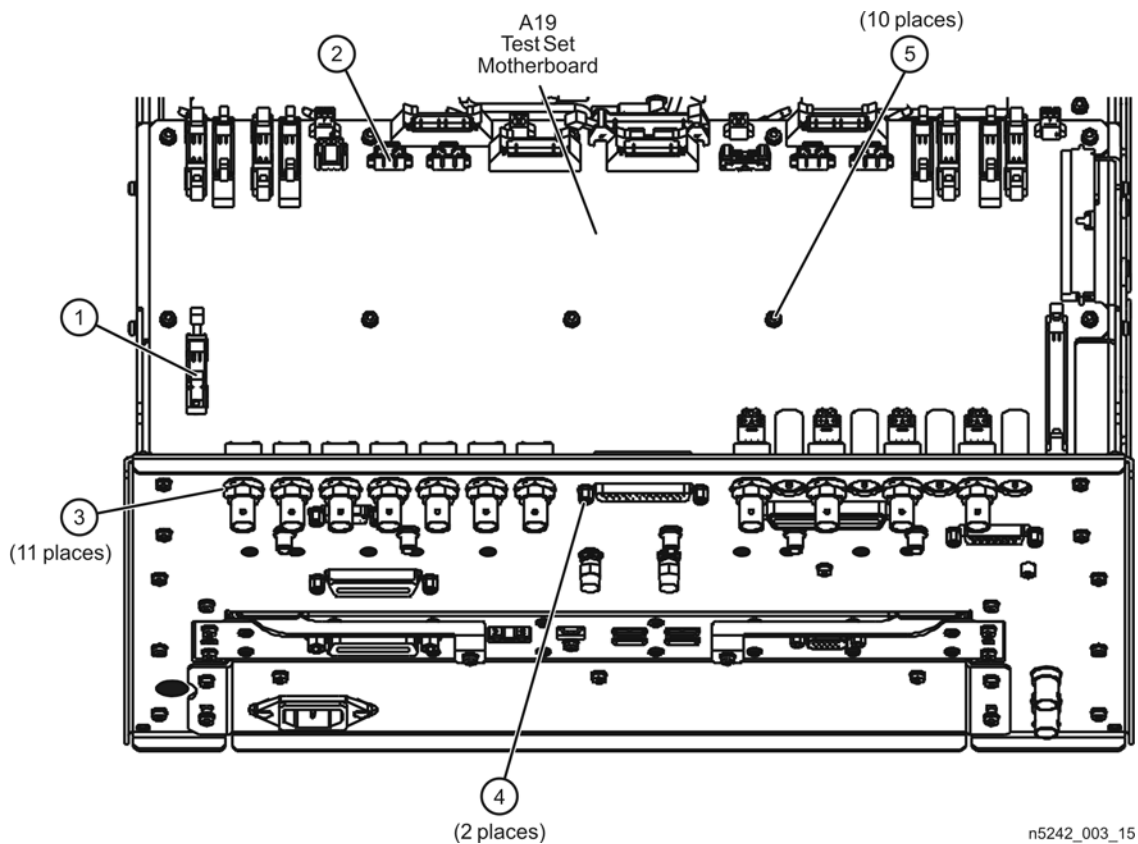

Remove the A20 IF Multiplexer Board

Refer to **Figure 13** for this part of this step of the procedure.

1. Disconnect the ribbon cable (item ①) from the A20 IF multiplexer board.
2. Disconnect ALL gray flexible RF cables (item ②) from the A20 IF multiplexer board. Make sure they are labeled for re-connection later.
3. Remove connector hardware (item ③) from five rear panel RF connectors.
4. Remove connector hardware (item ④) from the rear panel PULSE I/O connector.
5. Remove four screws (item ⑤) from the A20 IF multiplexer board.
6. Slide the A20 IF multiplexer board toward the front of the instrument until the rear panel connectors are free of the rear panel, then lift the board and remove it from the analyzer.

Figure 13 A20 IF Multiplexer Board Removal

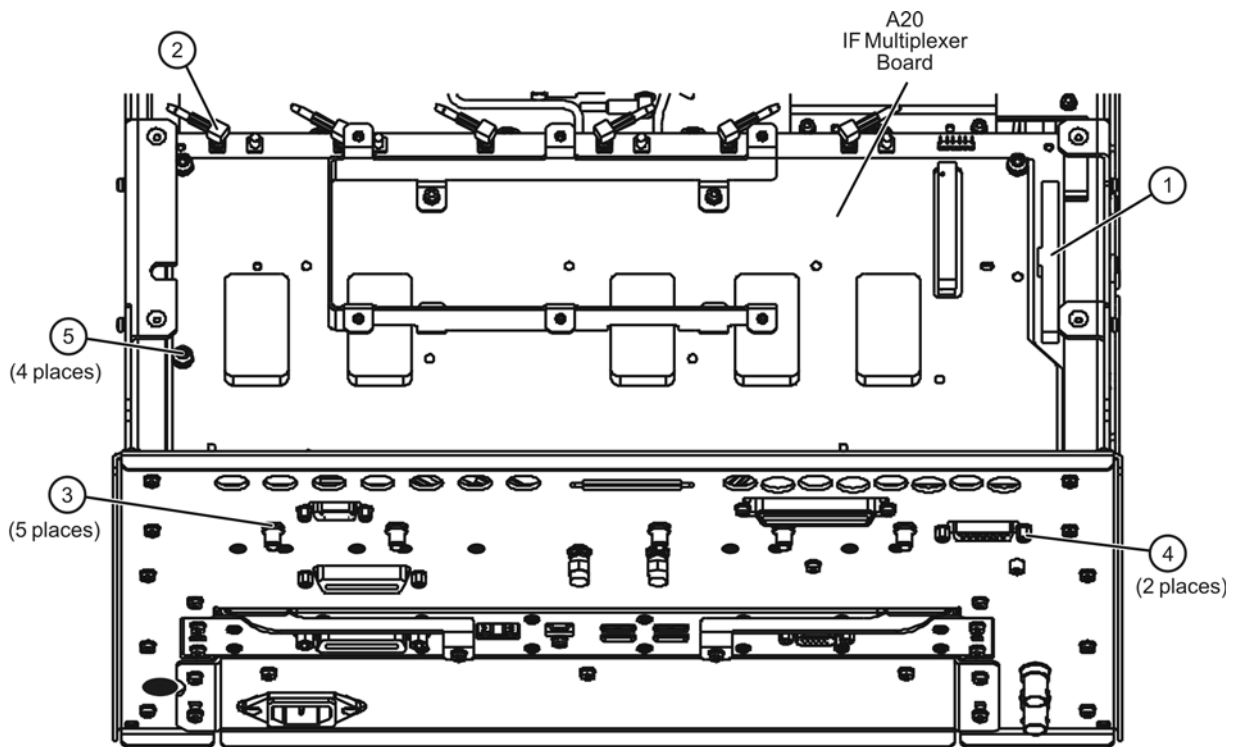

n5242_003_16

Step 11. Install the Bulkhead Connectors and Jumpers on the Rear Panel

1. Remove hole plugs from the following rear panel connector openings:

- PORT 1—COMB THRU IN (J10) and SW SRC OUT (J11)
- PORT 1—COMB ARM IN (J9) and SRC 2 SW SRC OUT (J8)
- PORT 3—SW TSET IN (J7)
- PORT 2—SW TSET IN (J1) and SW SRC OUT (J2)

Refer to [Figure 14](#) for this part of this step of the procedure. New parts are listed in [Table 1 on page 6](#).

2. Install bulkhead connectors, lock washers (item ①) and hex nuts (item ②) for the seven new rear panel cables. These cables will be installed later.

3. Using a 5/16-in torque wrench set to 21 in-lbs, tighten the hex nuts on the bulkhead connectors.

4. Install the three rear panel jumpers, W113, in the locations shown (and as listed below) and torque the connectors to 10 in-lbs:

- a. Jumper PORT 1 COMB THRU IN (J10) to PORT 1 SW SRC OUT (J11)
- b. Jumper PORT 1 COMB ARM IN (J9) to SRC 2 SW SRC OUT (J8)
- c. Jumper PORT 2 SW TSET IN (J1) to PORT 2 SW SRC OUT (J2)

5. Install a 50-ohm termination (item ③) on the PORT 3 SW TSET IN (J7) connector, as indicated, and torque the termination connector to 10 in-lbs.

Figure 14 Bulkhead Connectors and Jumpers on Rear Panel

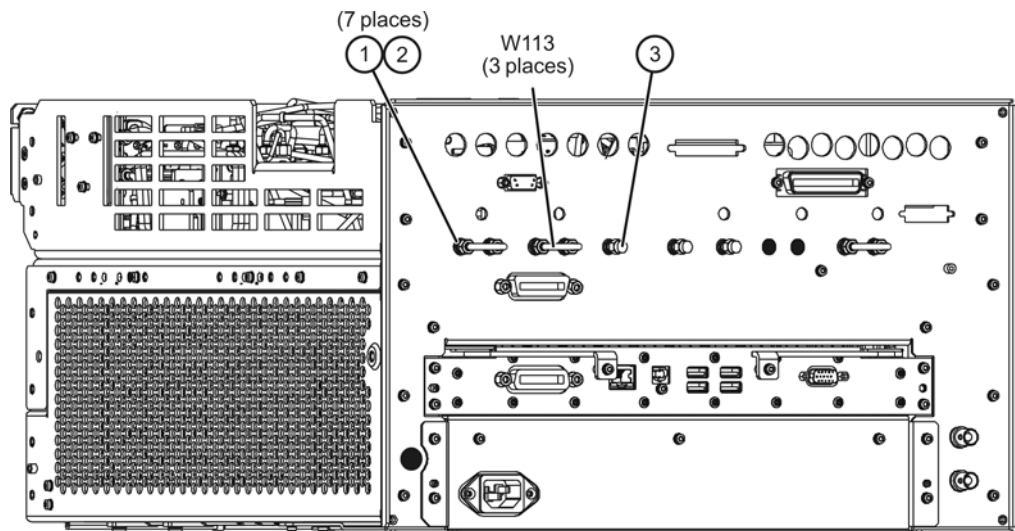

n5242_003_10-2

Step 12. Install the New Test Set Cables

CAUTION Follow instructions carefully when making cable connections, especially wire harness connections. Incorrect connections can destroy components, resulting in additional customer costs.

CAUTION Be careful not to damage the center pins of the semirigid cables. Some flexing of the cables may be necessary but do not over-bend them.

CAUTION Use a 5/16-in torque wrench set to 10 in-lbs on all cable connections except the front and rear panel bulkhead connectors. On these, use a 9 mm nutsetter or open end torque wrench set to 21 in-lb.

Refer to [Figure 15](#) for this part of this step of the procedure. New parts are listed in [Table 1 on page 6](#).

Install the following cables in the order listed. Use a 5/16-in torque wrench set to 10 in-lbs to tighten all cable connectors.

- W95 (N5242-20269) A46 port 1 mechanical switch (connector 2) to W3 (from A5 26.5 GHz source 1 board)
- W96 (N5242-20264) A46 port 1 mechanical switch (connector 3) to A25 test port 1 bridge
- W97 (N5242-20287) A46 port 1 mechanical switch to (connector 1) rear-panel PORT 1 SW SRC OUT (J11)
- W98 (N5242-20288) Rear-panel PORT 1 COMB THRU IN (J10) to A50 combiner
- W99 (N5242-20289) Rear-panel PORT 1 COMB ARM IN (J9) to A50 combiner
- W100 (N5242-20265) A50 combiner to A46 port 1 mechanical switch (connector 4)
- W101 (N5242-20266) W5 (from A8 26.5 GHz source 2 board) to A47 SRC 2 mechanical switch (connector 2)
- W103 (N5242-20282) A47 SRC 2 mechanical switch (connector 1) to rear-panel SRC 2 SW SRC OUT (J8)
- W104 (N5242-20281) Rear-panel PORT 3 SW TSET IN (J7) to A47 SRC 2 mechanical switch (connector 4)
- W109 (N5242-20268) W9 (from A5 26.5 GHz source 1 board) to A49 port 2 mechanical switch (connector 2)
- W25 (N5222-20038) A28 port 2 bridge to front-panel REF 2 SOURCE OUT
- W154 (N5242-20308) front panel REF 2 RCVR R2 IN to A23 mixer brick (R2)
- W110 (N5242-20262) A49 port 2 mechanical switch (connector 3) to A28 test port 2 bridge
- W111 (N5242-20285) A49 port 2 mechanical switch (connector 1) to rear-panel PORT 2 SW SRC OUT (J2)
- W112 (N5242-20286) Rear-panel PORT 2 SW TSET IN (J1) to A49 port 2 mechanical switch (connector 4)

- W68 (N5242-20291) W7 (from A8 26.5 GHz source 2 board) to front-panel SRC 2 OUT 2
- W67 (N5242-20290) A47 SRC 2 mechanical switch (connector 3) to front-panel SRC 2 OUT 1

Figure 15 **New Test Set Cable Installation**

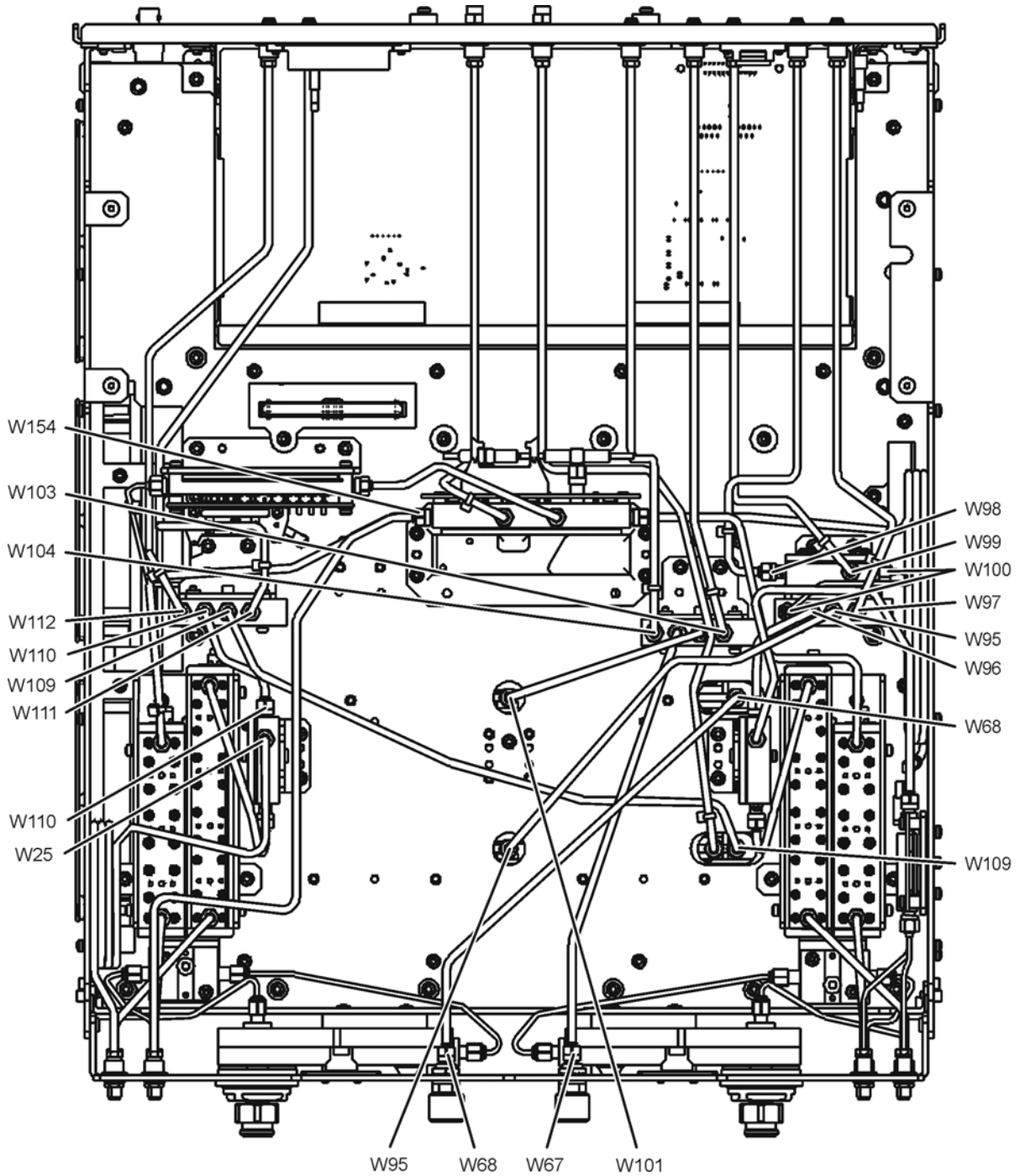

n5242_003_10-1

Step 13. Reinstall the A20 IF Multiplexer Board and the A19 Test Set Motherboard

Reinstall the A20 IF Multiplexer Board

Refer to **Figure 16** for this part of this step of the procedure.

1. Position the A20 IF multiplexer board in the analyzer and slide it toward the rear of the instrument until the rear panel connectors are completely through the rear panel.
2. *Loosely* reinstall four screws (item ⑤) in the A20 IF multiplexer board.
3. Reinstall connector hardware (item ③) on five rear panel RF connectors. Torque the hex nuts to 21 in-lbs.
4. Reinstall connector hardware (item ④) on the rear panel PULSE I/O connector. Torque the connector nuts to 6 in-lbs.
5. Torque the four screws (item ⑤) to 21 in-lbs.
6. Reconnect ALL gray flexible RF cables (item ②) to the A20 IF multiplexer board.
7. Reconnect the ribbon cable (item ①) to the A20 IF multiplexer board.

Figure 16 A20 IF Multiplexer Board Reinstallation

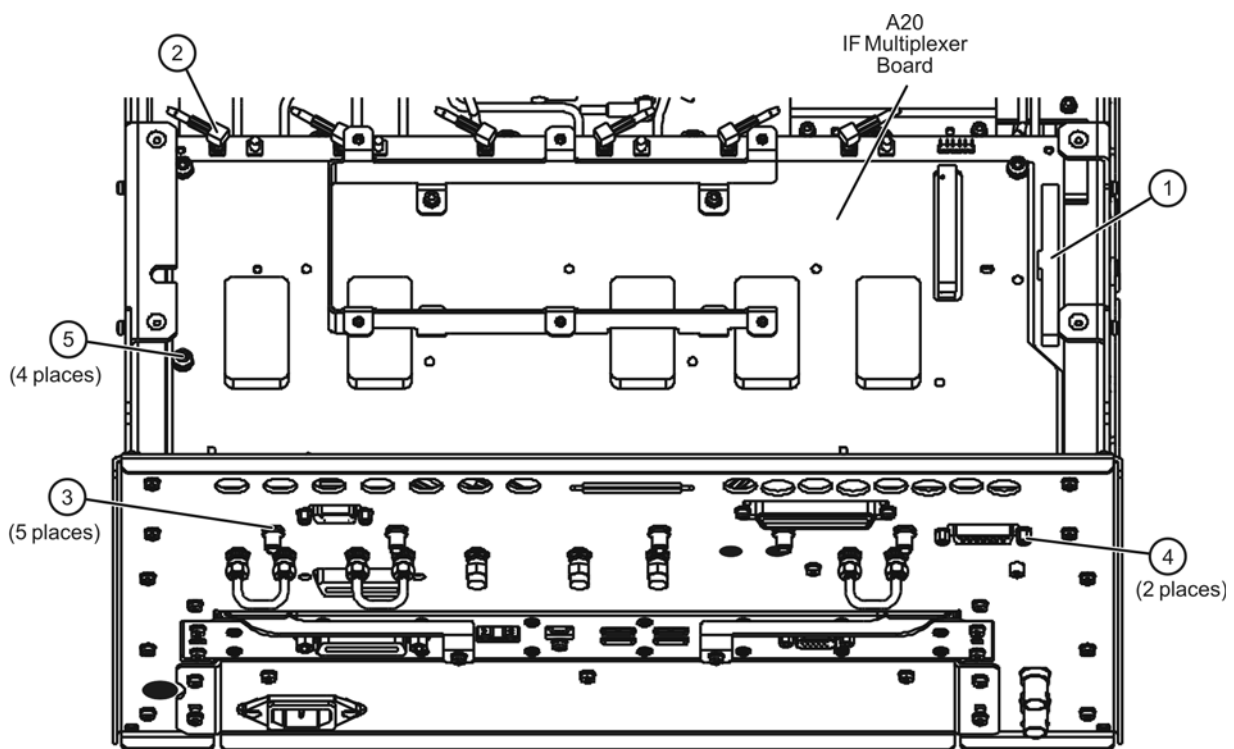

n5242_003_17

Reinstall the A19 Test Set Motherboard

Refer to [Figure 17](#) for this part of this step of the procedure.

1. Position the A19 test set motherboard in the analyzer and slide it toward the rear of the instrument until the rear panel BNC connectors are completely through the holes in the rear panel.
2. *Loosely* reinstall 10 screws (item ①) in the A19 test set motherboard.
3. Reinstall connector hardware (item ②) on 11 rear panel BNC connectors. Torque hex nuts to 21 in-lbs.
4. Reinstall connector hardware (item ③) on the rear panel TEST SET I/O connector. Torque connector nuts to 6 in-lbs.
5. Torque the 10 screws (item ①) to 9 in-lbs.
6. Reconnect ALL ribbon cables (item ④) and ALL wire harnesses (item ⑤) to the A19 test set motherboard.
7. Connect the mechanical switch control cables to the A19 test set motherboard as follows: A46 to item ⑥ (J101), A47 to item ⑦ (J102), A49 to item ⑧ (J104). Refer, if necessary, to [Figure 7 on page 16](#) for the locations of A46, A47, and A49.

Figure 17 A19 Test Set Motherboard Reinstallation

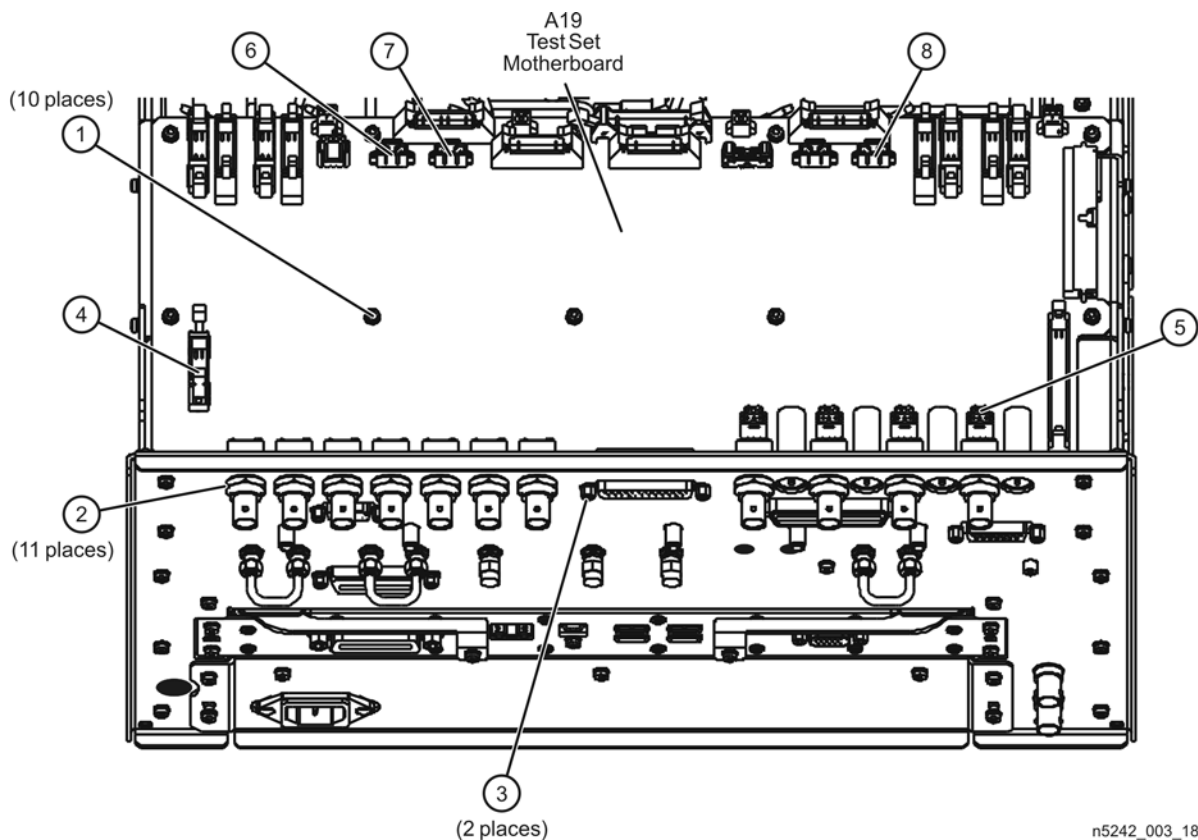

Step 14. Replace the Lower Front Panel Overlay

Refer to [Figure 18](#) for this step of the procedure. New parts are listed in [Table 1 on page 6](#).

1. From the back side of the front panel, use a blunt object in the cutouts in the lower front dress panel to push on the old overlay (item ①) and separate it from the front dress panel.
2. From the front side of the front panel, pull off the overlay completely and discard it.
3. Remove any adhesive remaining on the front panel.
4. Remove the protective backing from the new front panel overlay (item ②).
5. Starting from either side, *loosely* place the overlay in the recess on the lower front panel, ensuring that it fits tightly against the edges of the recess.
6. Once the overlay is in place, press it firmly onto the frame to secure it.

Figure 18 Lower Front Panel Overlay Replacement

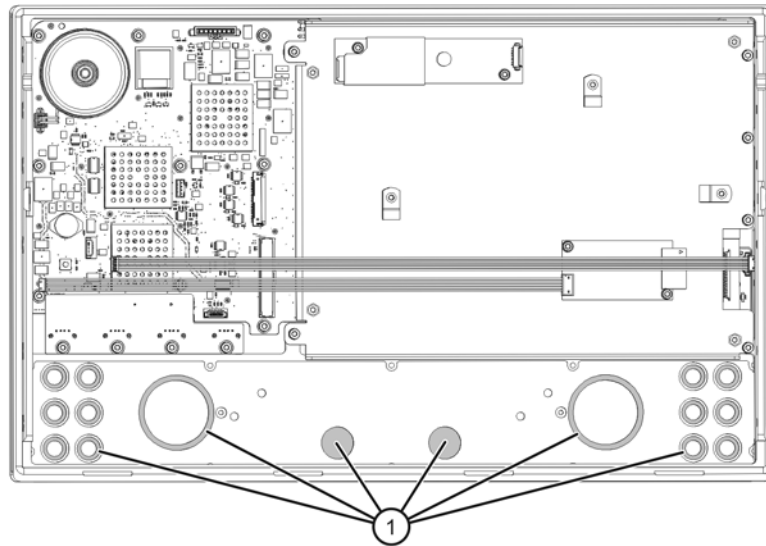

Old lower front-panel overlay visible through cutouts from rear of front panel.
Push here to release old front-panel overlay.

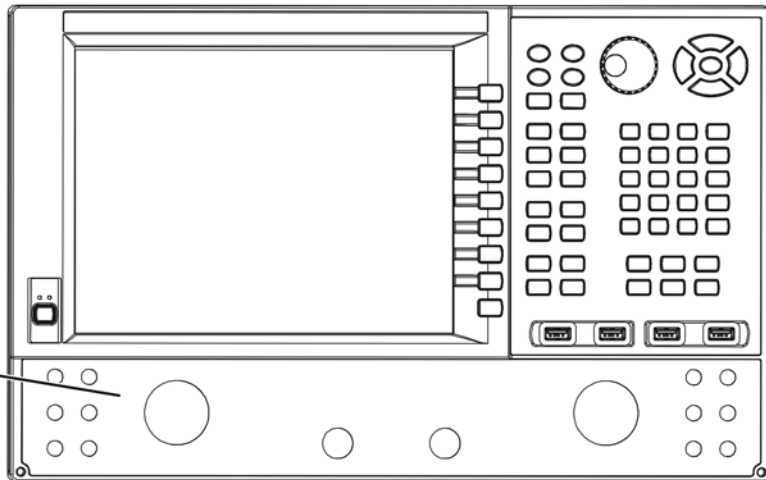

New lower front-panel overlay.
Align loosely to opening before pressing firmly.

n5242_003_11

Step 15. Reinstall the Front Panel Assembly and Front Panel Jumpers

CAUTION Before installing the front panel assembly onto the analyzer, lift and support the front of the analyzer chassis.

Refer to [Figure 19](#) for this step of the procedure. New parts are listed in [Table 1 on page 6](#).

1. Make sure all of the hex nuts on the front-panel cable connectors have been tightened using a 5/16-in torque wrench set to 21-in lbs.
2. Reconnect the ribbon cable (item ③) to the A1 front panel interface board.
3. Slide the front panel over the front-panel connectors.
4. With a T-10 TORX driver, reinstall the 12 screws (item ②) in the sides of the frame.
5. Reinstall the semirigid jumpers (item ①) on the front panel, and tighten each of the connectors to 10-in lbs.

Figure 19 Front Panel Assembly Reinstallation

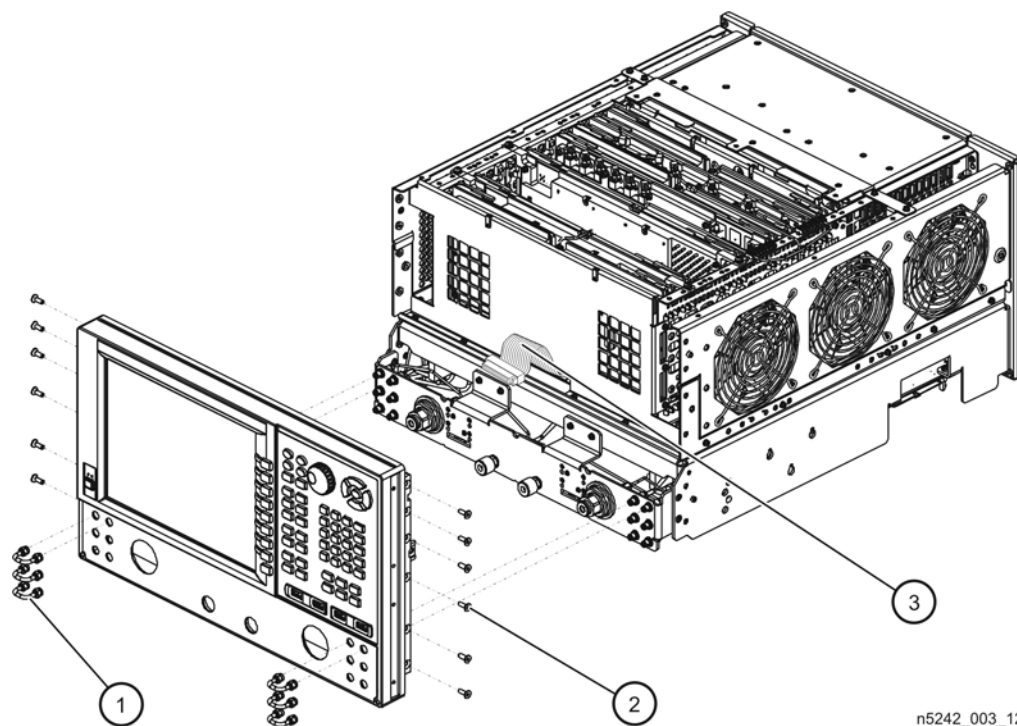

Step 16. Position the Cables and Wires to Prevent Pinching

On the top side of the PNA, carefully position the gray flex cables so they can't be pinched between the covers and the rails.

On the bottom side of the PNA, carefully fold or push down the ribbon cables and wires so they can't be pinched between the hardware and the outer cover. Ribbon cables and wires must never be positioned on top

of hardware.

Step 17. Reinstall the Inner Cover

Refer to **Figure 20** for this step of the procedure.

Figure 20 Inner Cover Reinstallation

- ① Lay inner cover on top of instrument.
- ② Hand start 3x screws 0515-1227. Torque to 9 in-lbs.
- ③ Hand start 6x screws 0515-0372. Torque to 9 in-lbs.

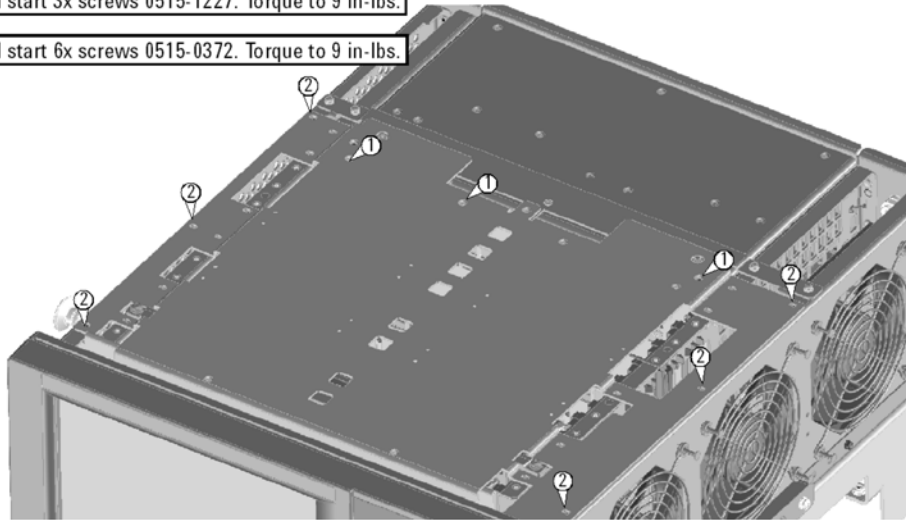

n5242_003_13

Step 18. Reinstall the Outer Cover

CAUTION This procedure is best performed with the analyzer resting on its front handles in the vertical position. *Do not place the analyzer on its front panel without the handles.* This will damage the front panel assemblies.

Refer to [Figure 21](#) for this step of the procedure.

1. Slide the outer cover over the analyzer frame.
2. Install the four rear panel feet (item ⑤) by installing the center screws (item ⑥) with a T-20 TORX driver.
3. Install the four bottom feet (item ④) onto the bottom of the outer cover then install the foot locks (item ③).
4. Install the strap handles (item ①) by tightening the screws (item ②) on both ends of each strap handle with a T-20 TORX driver.

Figure 21 Outer Cover Reinstallation

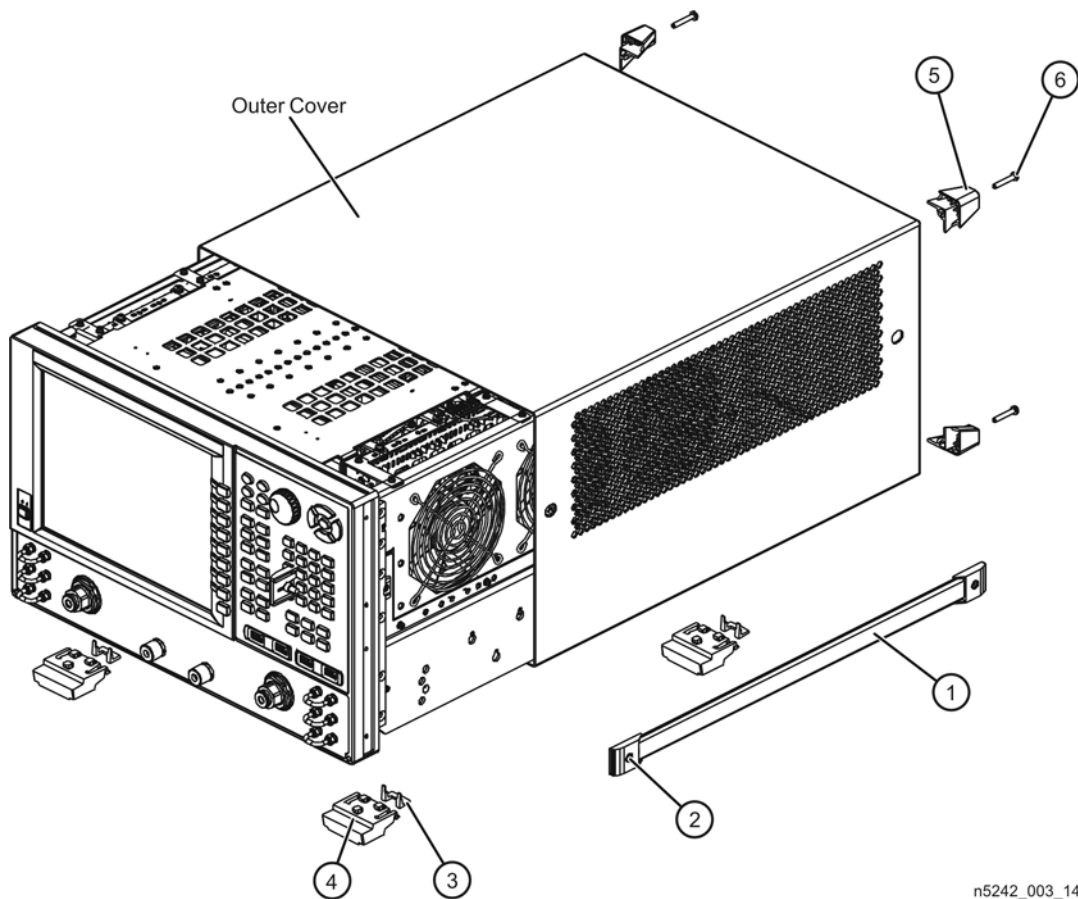

n5242_003_14

Step 19. Enable Option 224

Procedure Requirements

- The analyzer must be powered up and operating to perform this procedure.
- The Network Analyzer program must be running.
- A keyboard and mouse must be connected to the network analyzer.

Option Enable Procedure

1. To start the option enable utility, press UTILITY **System** , then **Service** , then **Option Enable** . An option enable dialog box will appear.
2. Click the arrow in the **Select Desired Option** box. A list of available options will appear.
3. In the **Select Desired Option** list, click **224 - 2nd Src w/Combiner & Switches**. Click **Enable**.
4. Using the keyboard, enter the license key in the box provided. The license key is printed on the license message you received from Keysight. Enter this key *exactly* as it is printed on the message.
5. Click **Enable**.
6. Click **Yes** in answer to the displayed question in the **Restart Analyzer?** box.
7. When the installation is complete, click **Exit**.

Option Verification Procedure

Once the analyzer has restarted and the Network Analyzer program is again running:

1. On the analyzer's **Help** menu, click **About Network Analyzer**.
2. Verify that "224" is listed after "Options:" in the display. Click **OK**.

NOTE If Option 224 has not been enabled, perform the "**Option Enable Procedure**" again. If the option is still not enabled, contact Keysight Technologies. Refer to "**Getting Assistance from Keysight**" on page 3.

Step 20. Perform Post-Upgrade Adjustments and Calibration

Adjustments

The following adjustments must be made due to the hardware changes of the analyzer.

- source adjustment
- receiver adjustment

These adjustments are described in the PNA Service Guide and in the PNA on-line HELP. A list of equipment required to perform these adjustments is also found in the service guide.

To view this service guide information, click the Chapter 3 bookmark “Tests and Adjustments” in the PDF Service Guide¹.

After the specified adjustments have been performed, the analyzer should operate and phase lock over its entire frequency range.

Operator’s Check

Perform the Operator’s Check to check the basic functionality of the analyzer. For instructions, click the Chapter 3 bookmark “Tests and Adjustments” in the PDF Service Guide¹.

If you experience difficulty with the basic functioning of the analyzer, contact Keysight. Refer to [“Contacting Keysight” on page 3](#).

Calibration

Although the analyzer functions, its performance relative to its specifications has not been verified. It is recommended that a full instrument calibration be performed using the analyzer’s internal performance test software. To view information on the performance test software, click the Chapter 3 bookmark “Tests and Adjustments” in the PDF Service Guide¹.

Step 21. Prepare the PNA for the User

1. If necessary, reinstall front jumper cables.
2. Install the cable guards, pushing them over the front jumper cables until the cushioning material touches the front panel of the PNA.
3. Install the dust caps on the test ports.
4. Clean the analyzer, as needed, using a damp cloth.

1. See [“Downloading the Online PNA Service Guide” on page 5](#).

This information is subject to change without notice.

© Keysight Technologies 2007 - 2014

December 1, 2014



N5242-90114
www.keysight.com