

Keysight Second Source, Combiner, and Mechanical Switches Upgrade Kit

To Upgrade PNA-X N5244A or N5245A Option 219 to
Option 224

For Analyzers with Serial Numbers Prefixed MY/SG/US5150
and Below

Upgrade Kit Order Numbers: N5244AU-922 and
N5245AU-922

Keysight Kit Number: N5245-60102

NOTICE: This document contains references to Agilent Technologies. Agilent's former Test and Measurement business has become Keysight Technologies. For more information, go to www.keysight.com.



WARRANTY STATEMENT

THE MATERIAL CONTAINED IN THIS DOCUMENT IS PROVIDED "AS IS," AND IS SUBJECT TO BEING CHANGED, WITHOUT NOTICE, IN FUTURE EDITIONS. FURTHER, TO THE MAXIMUM EXTENT PERMITTED BY APPLICABLE LAW, KEYSIGHT DISCLAIMS ALL WARRANTIES, EITHER EXPRESS OR IMPLIED WITH REGARD TO THIS MANUAL AND ANY INFORMATION CONTAINED HEREIN, INCLUDING BUT NOT LIMITED TO THE IMPLIED WARRANTIES OF MERCHANTABILITY AND FITNESS FOR A PARTICULAR PURPOSE. KEYSIGHT SHALL NOT BE LIABLE FOR ERRORS OR FOR INCIDENTAL OR CONSEQUENTIAL DAMAGES IN CONNECTION WITH THE FURNISHING, USE, OR PERFORMANCE OF THIS DOCUMENT OR ANY INFORMATION CONTAINED HEREIN. SHOULD KEYSIGHT AND THE USER HAVE A SEPARATE WRITTEN AGREEMENT WITH WARRANTY TERMS COVERING THE MATERIAL IN THIS DOCUMENT THAT CONFLICT WITH THESE TERMS, THE WARRANTY TERMS IN THE SEPARATE AGREEMENT WILL CONTROL.

DFARS/Restricted Rights Notice

If software is for use in the performance of a U.S. Government prime contract or subcontract, Software is delivered and licensed as "Commercial computer software" as defined in DFAR 252.227-7014 (June 1995), or as a "commercial item" as defined in FAR 2.101(a) or as "Restricted computer software" as defined in FAR 52.227-19 (June 1987) or any equivalent agency regulation or contract clause. Use, duplication or disclosure of Software is subject to Keysight Technologies' standard commercial license terms, and non-DOD Departments and Agencies of the U.S. Government will receive no greater than Restricted Rights as defined in FAR 52.227-19(c)(1-2) (June 1987). U.S. Government users will receive no greater than Limited Rights as defined in FAR 52.227-14 (June 1987) or DFAR 252.227-7015 (b)(2) (November 1995), as applicable in any technical data.

Safety Notes

The following safety notes are used throughout this document. Familiarize yourself with each of these notes and its meaning before performing any of the procedures in this document.

WARNING **Warning denotes a hazard. It calls attention to a procedure which, if not correctly performed or adhered to, could result in injury or loss of life. Do not proceed beyond a warning note until the indicated conditions are fully understood and met.**

CAUTION Caution denotes a hazard. It calls attention to a procedure that, if not correctly performed or adhered to, could result in damage to or destruction of the instrument. Do not proceed beyond a caution note until the indicated conditions are fully understood and met.

Description of the Upgrade

This upgrade converts your standard 2-port configurable test set analyzer (N5244A Option 219 or N5245A Option 219) to an N5244A Option 224 or N5245A Option 224 by adding:

- a second source assembly
- a second 13.5 GHz synthesizer board
- two additional doublers
- source outputs routed to the front panel
- source outputs routed to the rear panel
- a mechanical switch to each source port channel
- a source combiner to the port 1 channel
- rear-panel test set inputs

Getting Assistance from Keysight

By internet, phone, or fax, get assistance with all your test and measurement needs.

Contacting Keysight

Assistance with test and measurements needs and information on finding a local Keysight office are available on the Web at:

<http://www.keysight.com/find/assist>

If you do not have access to the Internet, please contact your Keysight field engineer.

NOTE In any correspondence or telephone conversation, refer to the Keysight product by its model number and full serial number. With this information, the Keysight representative can determine whether your product is still within its warranty period.

If You Have Problems With the Upgrade Kit Contents

Keysight stands behind the quality of the upgrade kit contents. If you have problems with any item in the kit, email Keysight Component Test Division (CTD) Support at support_ctd-soco@keysight.com, or telephone the CTD Hotline at (707) 577-6802 and leave a voice mail message. Please include details of the problem.

Getting Prepared

CAUTION The PNA contains extremely sensitive components that can be ruined if mishandled. Follow instructions carefully when making cable connections, especially wire harness connections.

The person performing the work accepts responsibility for the full cost of the repair or replacement of damaged components.

To successfully install this upgrade kit, you will need the following:

- A license key - refer to “[License Key Redemption](#)” below.
- A PDF copy or a paper copy of the PNA Service Guide - refer to “[Downloading the Online PNA Service Guide](#)” below.
- An ESD-safe work area - refer to “[Protecting Your Workspace from Electrostatic Discharge](#)” below.
- Correct tools - refer to “[Tools Required for the Installation](#)” on page 6.
- Enough time - refer to “[About Installing the Upgrade](#)” on page 6.
- Test equipment for the post-upgrade adjustments and full instrument calibration. To view the equipment list, click the Chapter 3 bookmark “[Tests and Adjustments](#)” in the PDF Service Guide¹.

License Key Redemption

NOTE The enclosed Option Entitlement Certificate is a receipt, verifying that you have purchased a licensed option for the PNA of your choice. You must now use a Keysight Web page to request a license key for the instrument that will receive the option.

To enable the option product, you must request a license key from: <http://www.keysight.com/find/softwarelicense>. To complete the request, you will need to gather the following information:

- From the certificate
 - Order number
 - Certificate number
- From your instrument
 - Model number
 - Serial number
 - Host ID

The instrument information is available on the network analyzer – on the analyzer’s **Help** menu, click **About Network Analyzer**.

If you provide an email address, Keysight will promptly email your license key. Otherwise, you will receive your license key via postal mail.

1. See “[Downloading the Online PNA Service Guide](#)” on page 5.

Downloading the Online PNA Service Guide

To view the online Service Guide for your PNA model number, use the following steps:

1. Go to www.keysight.com.
2. In the Search box, enter the model number of the analyzer (Ex: N5242A) and click **Search**.
3. Click [Technical Support > Manuals](#).
4. Click [Service Manual](#).
5. Click the service guide title to download the PDF file.
6. When the PDF of the Service Guide is displayed, scroll through the Contents section bookmarks to locate the information needed.

Protecting Your Workspace from Electrostatic Discharge

For information, click on the Chapter 1 bookmark, “Electrostatic Discharge Protection” in the PDF Service Guide¹.

ESD Equipment Required for the Installation

Description	Keysight Part Number
ESD grounding wrist strap	9300-1367
5-ft grounding cord for wrist strap	9300-0980
2 x 4 ft conductive table mat and 15-ft grounding wire	9300-0797
ESD heel strap (for use with conductive floors)	9300-1308

1. See [“Downloading the Online PNA Service Guide”](#) on page 5.

Tools Required for the Installation

Description	Qty	Part Number
T-6 TORX driver - set to 4 in-lbs (0.45 N.m)	1	N/A
T-8 TORX driver - set to 6 in-lbs (0.68 N.m)	1	N/A
T-10 TORX driver - set to 9 in-lbs (1.02 N.m)	1	N/A
T-20 TORX driver - set to 21 in-lbs (2.38 N.m)	1	N/A
5/16-in (8 mm) nutsetter or open end torque wrench- set to 10 in-lbs (1.13 N.m)	1	N/A
5/16-in (8 mm) nutsetter or open end torque wrench - set to 21 in-lbs (2.38 N.m)	1	N/A
3/16-in (5 mm) nutsetter or open end torque wrench - set to 6 in-lbs (0.68 N.m)	1	N/A
9/16-in (15 mm) nutsetter or open end torque wrench - set to 21 in-lbs (2.38 N.m)	1	N/A
5/8-in (16 mm) nutsetter or open end torque wrench - set to 21 in-lbs (2.38 N.m)	1	N/A
9 mm nutsetter or open end torque wrench - set to 21 in-lbs (2.38 N.m)	1	N/A
1/4-in (6 mm) open end wrench	1	N/A

CAUTION Use a 5/16-in torque wrench set to 10 in-lbs on all cable connections except the front and rear panel cable connectors. On these, use a 9 mm nutsetter or open end torque wrench set to 21 in-lb.

About Installing the Upgrade

Products affected	N5244A and N5245A Option 219
Installation to be performed by	Keysight service center or personnel qualified by Keysight
Estimated installation time	5.0 hours
Estimated adjustment time	0.5 hour
Estimated full instrument calibration time	4.5 hours

Items Included in the Upgrade Kit

Check the contents of your kit against the following list. If any part is missing or damaged, contact Keysight Technologies. Refer to [“Getting Assistance from Keysight” on page 3](#).

Table 1 Contents of Upgrade Kit N5245-60102

Ref Desig.	Description	Qty	Part Number
--	Installation note (this document)	1	N5245-90005
A10	26.5 GHz source (2) assembly	1	5087-7780 Was 5087-7327
A12	Doubler assembly, port 3	2	5087-7349
A13	Doubler assembly, port 4		Was 5087-7318
A17	13.5 GHz source 2 synthesizer board ^a	3	N5240-60076 Was N5242-60166
A50	Port 1 mechanical switch	3	N1811-60031 Was N1811-60009
A51	SRC2 OUT1 mechanical switch		
A53	Port 3 mechanical switch		
A54	Combiner	1	11667-60021 Was N5532-60002
--	Bracket for combiner	1	N5245-00020
--	Bracket for mechanical switches	3	N5245-00014
--	Bracket for cables	1	N5245-00022
-	Machine screw, M3.0 x 8, pan head (to attach cable bracket to deck)	2	0515-0372
-	Machine screw, M2.0 x 20, pan head (to attach mechanical switches to brackets)	6	0515-1992
--	Machine screw, M2 x 14, pan head (to attach combiner to bracket)	2	0515-0661
--	Machine screw, M3 x 6, pan head (6 to attach switch assemblies to deck; 2 to attach combiner bracket to deck)	8	0515-0430
-	Machine screw, M4.0 x 10, pan head (2 to attach source 2 assy to chassis; 2 to attach A12 doubler 3 to chassis; 2 to attach A13 doubler 4 to chassis)	6	0515-0380
--	Cable clamp	5	1400-1334
--	Bulkhead connectors	2	5063-1700
--	Washers for bulkhead connectors	2	2190-0016
--	Nuts for bulkhead connectors	2	08360-20133
--	Front panel overlay	1	N5245-80005
-	Dust cap for test port	2	1401-0214
-	Dust cap for test port	2	1401-0225
-	Termination, 2.4 mm 50 GHz load	1	0955-2394
W2	A10 source (2) P1 to A17 13.5 GHz source (2) synthesizer J1207	1	N5245-20100

Table 1 Contents of Upgrade Kit N5245-60102

Ref Desig.	Description	Qty	Part Number
W7	A10 source (2) P5 to A12 port 3 doubler	1	N5245-20034
W8	A10 source (2) P3 to A13 port 4 doubler	1	N5245-20035
W9	A10 source (2) P4 to A12 port 3 doubler	1	N5245-20032
W10	A12 port 3 doubler to A13 port 4 doubler	1	N5245-20033
W13	A12 port 3 doubler to W14	1	N5245-20036
W15	A13 port 4 doubler to W16	1	N5245-20036
W16	Front panel SRC 2 OUT 2 to W15	1	N5245-20053
W77	A14 frequency ref (J7) to A17 13.5 GHz (source 2) synth (J5)	1	N5242-60030
W105	A50 port 1 mechanical switch to W11	1	N5245-20064
W106	A50 port 1 mechanical switch to A29 port 1 reference coupler	1	N5245-20065
W107	A50 port 1 mechanical switch to PORT 1 SW SRC OUT (J11)	1	N5245-20068
W108	Rear-panel PORT 1 COMB THRU IN (J10) to A54 combiner	1	N5245-20094
W109	Rear-panel PORT 1 COMB ARM IN (J9) to A54 combiner	1	N5245-20093
W110	A50 port 1 mechanical switch to A54 combiner	1	N5245-20067
W111	A51 SRC2 OUT1 mechanical switch mechanical switch to W13	1	N5245-20058
W112	Front panel SRC 2 OUT 1 to A51 SRC2 OUT1 mechanical switch	1	N5245-20078
W113	A51 SRC2 OUT1 mechanical switch to PORT 3 SW SRC OUT (J8)	1	N5245-20069
W114	Rear-panel PORT 3 SW TSET IN (J7) to A51 SRC2 OUT1 mechanical switch	1	N5245-20070
W119	A53 port 2 mechanical switch to W17	1	N5245-20063
W120	A53 port 2 mechanical switch to A32 port 2 reference coupler	1	N5245-20062
W121	A53 port 2 mechanical switch to PORT 2 SW SRC OUT (J2)	1	N5245-20071
W122	A53 port 2 mechanical switch to PORT 2 TSET IN (J1)	1	N5245-20072
W123	Rear panel jumper	3	N5245-20155 Was N5245-20104

- a. The three 13.5 GHz Synthesizer boards included in this kit are the RoHS compliant N5240-60076 boards. These new boards are not compatible with the old N5230-60002 13.5 GHz Synthesizer boards. If the boards installed in your PNA are the old N5230-60002, you must replace ALL of them with the N5240-60076 boards included in this kit - refer to your PNA Service Guide's chapter 7 for instructions. If your PNA already contains the new boards, scrap the two extra N5240-60076 boards included in this kit.

For the new N5240-60076 boards to function properly in your PNA, you must upgrade your PNA firmware to rev A09.33xx or above. Download PNA firmware at: <http://na.support.keysight.com/pna/firmware/firmware.html>.

NOTE Extra quantities of items such as protective plastic caps, screws, cable ties, and cable clamps may be included in this upgrade kit. It is normal for some of these items to remain unused after the upgrade is completed.

Installation Procedure for the Upgrade

The network analyzer must be in proper working condition prior to installing this option. Any necessary repairs must be made before proceeding with this installation.

WARNING **This installation requires the removal of the analyzer’s protective outer covers. The analyzer must be powered down and disconnected from the mains supply before performing this procedure.**

Overview of the Installation Procedure

- Step 1. Obtain a Keyword and Verify the Information.
- Step 2. Remove the Outer Cover.
- Step 3. Remove the Inner Cover.
- Step 4. Remove the Front Panel Assembly.
- Step 5. Remove the A23 Test Set Motherboard.
- Step 6. Remove the A24 IF Multiplexer Board.
- Step 7. Remove Some Existing Cables.
- Step 8. Assemble the A50, A51, and A53 Mechanical Switch Assemblies.
- Step 9. Install the Mechanical Switch Assemblies.
- Step 10. Assemble and Install the A54 Combiner Assembly.
- Step 11. Install the Source 2 Front Panel Connectors.
- Step 12. Assemble the A10 26.5 GHz Source 2 Assembly.
- Step 13. Assemble and Install the A12 and A13 Doubler Assemblies.
- Step 14. Install the A10 26.5 GHz Source 2 Assembly and Cables.
- Step 15. Install the A17 13.5 GHz (Source 2) Synthesizer Board and Cables.
- Step 16. Install the New Cables.
- Step 17. Install Rear Panel Hardware.
- Step 18. Reinstall the A24 IF Multiplexer Board.
- Step 19. Reinstall the A23 Test Set Motherboard.
- Step 20. Replace the Lower Front Panel Overlay.
- Step 21. Reinstall Front Panel Assembly.
- Step 22. Position the Cables and Wires to Prevent Pinching.
- Step 23. Reinstall the Inner Cover.
- Step 24. Reinstall the Outer Cover.
- Step 25. Enable Option 224.

Step 26. Perform Post-Upgrade Adjustments and Calibration.

Step 27. Prepare the PNA for the User.

Step 1. Obtain a Keyword and Verify the Information

Follow the instructions on the Option Entitlement Certificate supplied to obtain a license key for installation of this upgrade. Refer to [“License Key Redemption” on page 4](#).

Verify that the model number, serial number, and option number information on the license key match those of the instrument on which this upgrade will be installed.

If the model number, serial number, or option number do not match those on your license key, you will not be able to install the option. If this is the case, contact Keysight for assistance before beginning the installation of this upgrade. Refer to [“Contacting Keysight” on page 3](#).

Once the license key has been received and the information verified, you can proceed with the installation at step 2.

Step 2. Remove the Outer Cover

For instructions, click the Chapter 7 bookmark “Removing the Covers” in the PDF Service Guide¹.

Step 3. Remove the Inner Cover

For instructions, click the Chapter 7 bookmark “Removing the Covers” in the PDF Service Guide¹.

Step 4. Remove the Front Panel Assembly

For instructions, click the Chapter 7 bookmark “Removing and Replacing the Front Panel Assembly” in the PDF Service Guide¹.

Step 5. Remove the A23 Test Set Motherboard

For instructions, click the Chapter 7 bookmark “Removing and Replacing the A23 Test Set Motherboard” in the PDF Service Guide¹.

Step 6. Remove the A24 IF Multiplexer Board

For instructions, click the Chapter 7 bookmark “Removing and Replacing the A24 IF Multiplexer Board” in the PDF Service Guide¹.

1. See [“Downloading the Online PNA Service Guide” on page 5](#).

Step 7. Remove Some Existing Cables

NOTE Be careful not to damage the center pins of the semirigid cables. Some flexing of the cables may be necessary but do not over-bend them.

NOTE Leave the gray flexible cables, the wire harnesses, and the ribbon cables connected where possible. **Any that are removed should be labeled for reconnection later.**

NOTE When removing a cable, also remove the plastic cable clamp, if present. It is normal for some of the cable clamp's adhesive to remain.

1. Place the analyzer bottom-side up on a flat surface.
2. Remove the following cables in the order listed. To see an image showing the location of these cables, click the Chapter 6 bookmark "Bottom RF Cables, Standard 2-Port Configuration, Option 219" in the PDF Service Guide¹.

These two cables may be discarded - they will not be reinstalled.

- W18 (N5245-20049) A32 test port 2 reference coupler to W17
- W12 (N5245-20050) A29 test port 1 reference coupler to W11

These four cables must be saved - they will be reinstalled.

- W98 (N5245-20056) A46 port 1 receiver attenuator to A27 mixer brick (A)
- W43 (N5245-20009) A37 reference mixer switch to A27 mixer brick (R1)
- W47 (N5245-20119) Front panel REF 2 RCVR R2 IN to A27 mixer brick (R2)
- W104 (N5245-20057) A49 port 2 receiver attenuator to A27 mixer brick (B)

1. See "Downloading the Online PNA Service Guide" on page 5.

Step 8. Assemble the A50, A51, and A53 Mechanical Switch Assemblies

Refer to [Figure 1](#) for this step of the procedure. New parts are listed in [Table 1 on page 7](#).

Figure 1 Mechanical Switch Assembly

① Prefab switches N1811-60031 X3 to brackets N5245-00014 X3 as shown. Secure with screws 0515-1992 X6, two screws to each switch. Torque to 6 in-lbs.

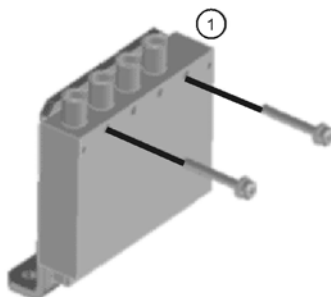

N5245_005_02

Step 9. Install the Mechanical Switch Assemblies

Install the A50, A51, and A53 mechanical switches. For instructions, click the Chapter 7 bookmark, “Removing and Replacing the A50-A53 Mechanical Switches and the A54 Combiner” in the PDF Service Guide¹. New parts are listed in [Table 1 on page 7](#) of this document.

Step 10. Assemble and Install the A54 Combiner Assembly

Refer to [Figure 2](#) for this step of the procedure. New parts are listed in [Table 1 on page 7](#).

1. See [“Downloading the Online PNA Service Guide” on page 5](#).

Figure 2 A54 Combiner Assembly and Installation

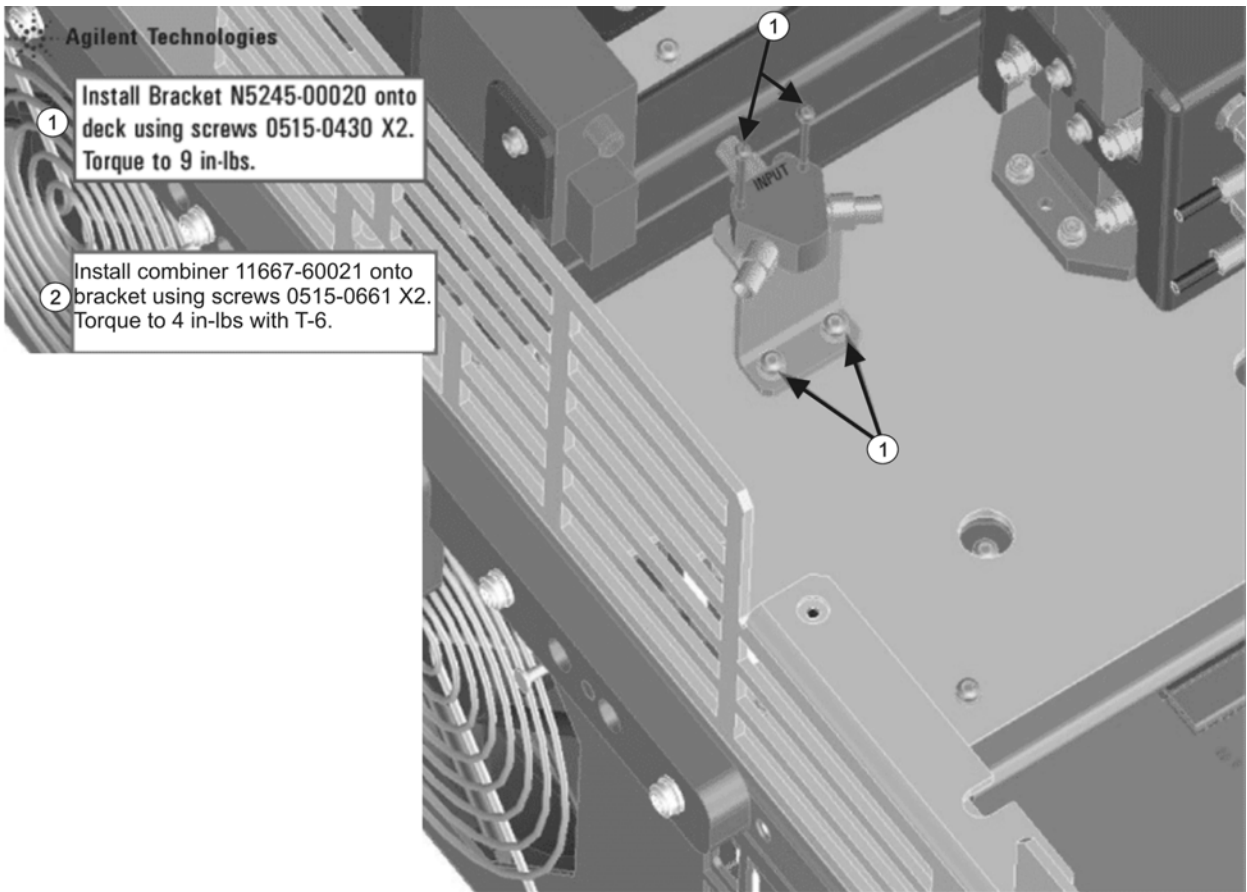

N5245_005_03

Step 11. Install the Source 2 Front Panel Connectors

Refer to [Figure 3](#) for this step of the procedure. New parts are listed in [Table 1](#) on [page 7](#).

Figure 3 Source 2 Front Panel Connectors Installation

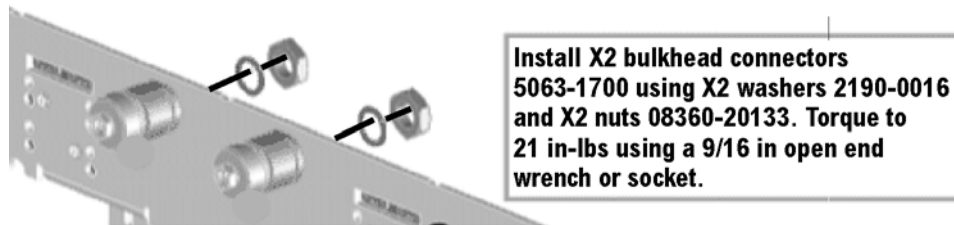

N5245_005_04

Step 12. Assemble the A10 26.5 GHz Source 2 Assembly

Follow the four instructions shown in [Figure 4](#).

Figure 4 A10 Source 2 Assembly



① Gather Source 5087-7780.

② Remove 50 ohm load - keep to install later on doubler #4. Install cable N5245-20032. Torque to 10 in-lbs.

③ Install Rigid Cable N5245-20034, Torque to 10 in-lbs

④ Install Rigid Cable N5245-20035, Torque to 10 in-lbs.

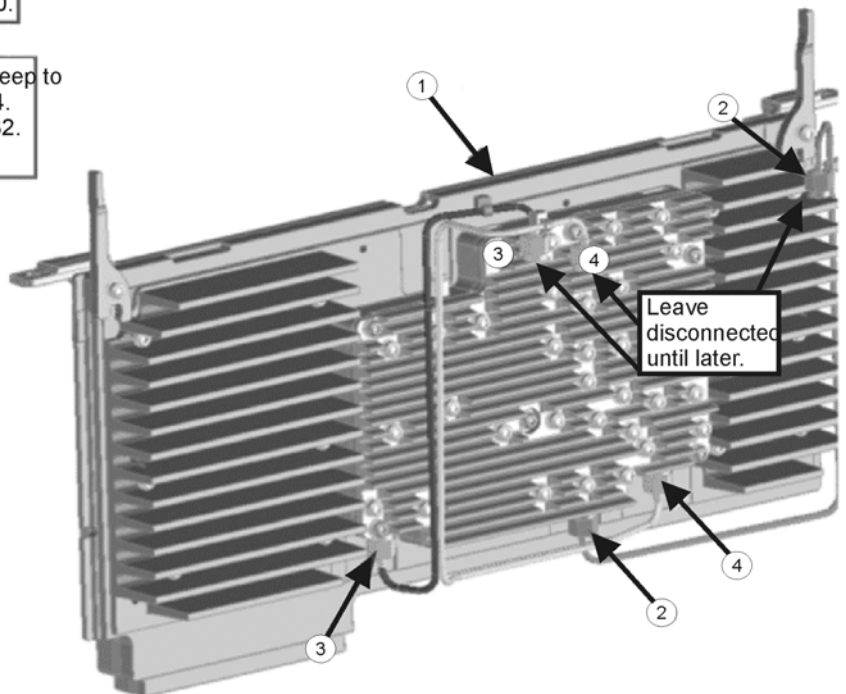

N5245_016_38

Step 13. Assemble and Install the A12 and A13 Doubler Assemblies

Follow the four instructions shown in [Figure 5](#).

Figure 5 A12 and A13 Doubler Assemblies Installation

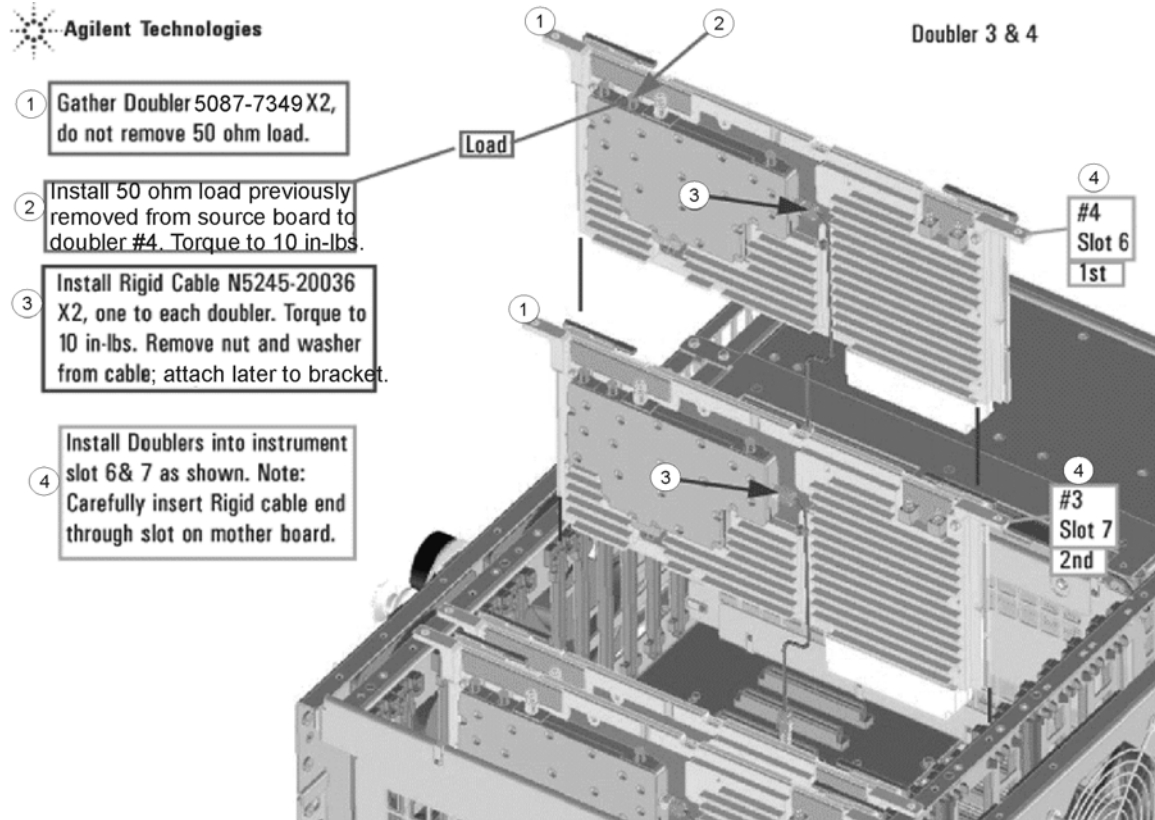

N5245_015_37

Step 14. Install the A10 26.5 GHz Source 2 Assembly and Cables

Follow the four instructions shown in [Figure 6](#).

Figure 6 A10 Source 2 Assembly Installation

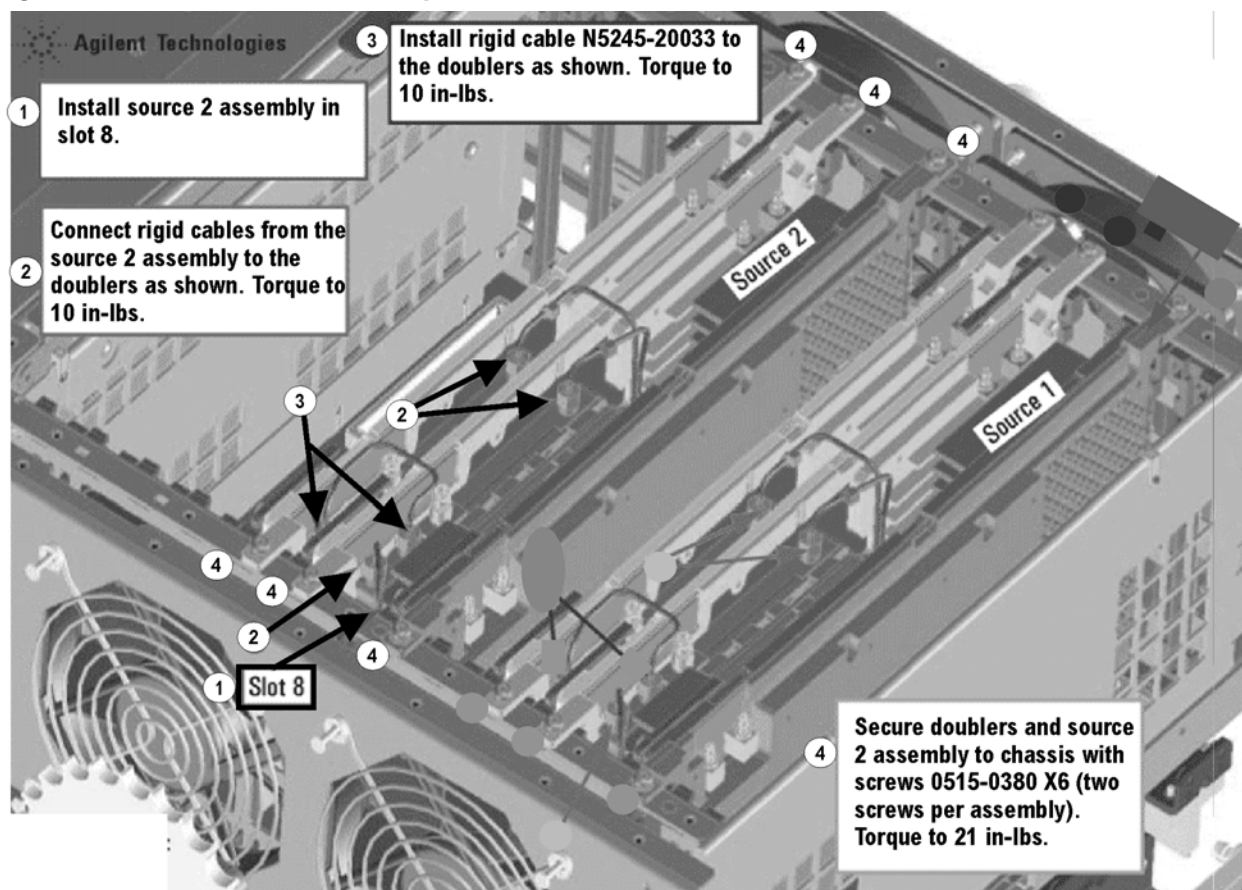

N5245_015_39

Step 15. Install the A17 13.5 GHz (Source 2) Synthesizer Board and Cables

1. Install gray cable W77 (N5242-60030) to connector J5 of the A17 (source 2) synthesizer board (N5230-60002). The loose end of the cable will be connected on the A14 frequency reference board (J7) after the A17 board has been installed in the analyzer.
2. Install the A17 board into slot 2 in the motherboard. To see an image showing the location of the A17 board in the motherboard, click the Chapter 6 bookmark "Top Assemblies, All Options" in the PDF Service Guide¹.
3. Connect cable W2 (N5245-20100) between the A10 source 2 board and the A17 (source 2) synthesizer board, positioning the cable in the wire looms. Tighten the cable connectors to 10 in-lbs using a 5/16-in torque wrench.
4. Connect the loose end of new gray flex cable W77 (N5242-60030) on the A14 frequency reference board (J7). (The other end of this cable was previously connected to J5 of the source 2 synthesizer board.)

1. See ["Downloading the Online PNA Service Guide"](#) on page 5.

NOTE The three 13.5 GHz Synthesizer boards included in this kit are the RoHS compliant N5240-60076 boards. These new boards are not compatible with the old N5230-60002 13.5 GHz Synthesizer boards. If the boards installed in your PNA are the old N5230-60002, you must replace ALL of them with the N5240-60076 boards included in this kit - refer to your PNA Service Guide's chapter 7 for instructions. If your PNA already contains the new boards, scrap the two extra N5240-60076 boards included in this kit.

For the new N5240-60076 boards to function properly in your PNA, you must upgrade your PNA firmware to rev A09.33xx or above. Download PNA firmware at:
<http://na.support.keysight.com/pna/firmware/firmware.html>.

Step 16. Install the New Cables

CAUTION Follow instructions carefully when making cable connections, especially wire harness connections. Incorrect connections can destroy components, resulting in additional customer costs.

CAUTION Be careful not to damage the center pins of the semirigid cables. Some flexing of the cables may be necessary but do not over-bend them.

CAUTION Use a 5/16-in torque wrench set to 10 in-lbs on all cable connections except the front and rear panel bulkhead connectors. On these, use a 9 mm nutsetter or open end torque wrench set to 21 in-lb.

Install the Semirigid Cables

To see an image showing the location of these cables, click the Chapter 6 bookmarks "Bottom RF Cables, 2-Port Configuration, Option 224" in the PDF Service Guide¹. New parts are listed in [Table 1 on page 7](#).

Install the following new cables in the order listed.

- Follow the two instructions shown in [Figure 7](#) in this document.

1. See "[Downloading the Online PNA Service Guide](#)" on page 5.

Figure 7 Semirigid Cables Installation

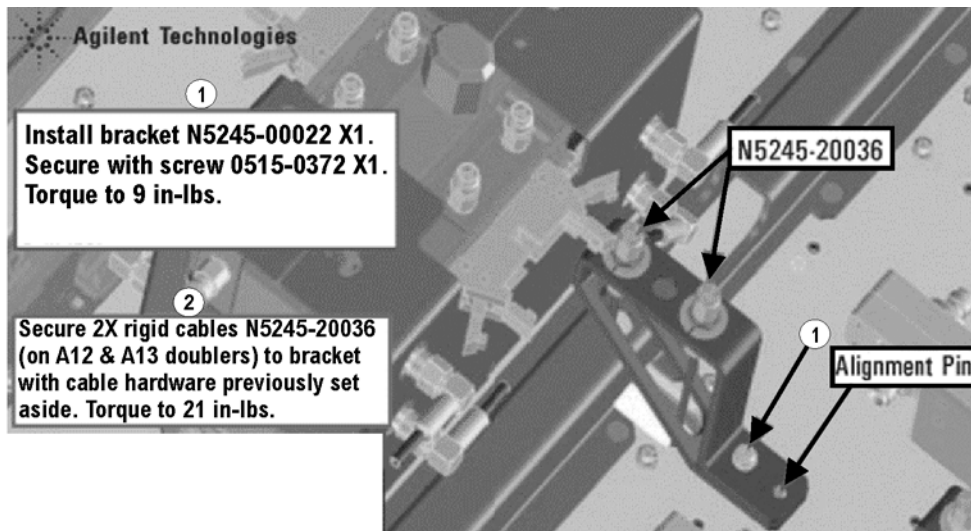

N5245_015_32

- W13 (N5245-20036) A12 port 3 doubler to W14 (connected to the doubler in an earlier step)
 - W15 (N5245-20036) A13 port 4 doubler to W16 (connected to the doubler in an earlier step)
 - W122 (N5245-20072) A53 port 2 mechanical switch to PORT 2 TSET IN (J1)
 - W121 (N5245-20071) A53 port 2 mechanical switch to PORT 2 SW SRC OUT (J2)
- * As shown in **Figure 8**, install a clamp (part number 1400-1334) to secure W121 (N5245-20071) and W122 (N5245-20072).

Figure 8 **Location of Cable Clamp to Secure W121 (N5245-20071) and W122 (N5245-20072)**

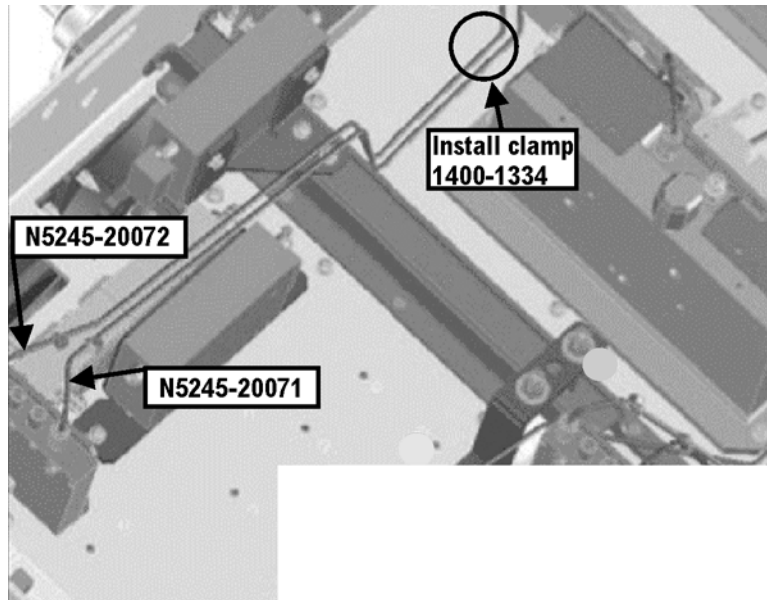

N5245_005_01

- W114 (N5245-20070) Rear-panel PORT 3 SW TSET IN (J7) to A51 SRC2 OUT1 mechanical switch
- W113 (N5245-20069) A51 SRC2 OUT1 mechanical switch to PORT 3 SW SRC OUT (J8)
- W109 (N5245-20093) Rear-panel PORT 1 COMB ARM IN (J9) to A54 combiner
- W108 (N5245-20094) Rear-panel PORT 1 COMB THRU IN (J10) to A54 combiner

- W107 (N5245-20068) A50 port 1 mechanical switch to PORT 1 SW SRC OUT (J11)
- * As shown in **Figure 9**, install clamp part number 1400-1334 to secure W107 (N5245-20068).

Figure 9 Location of Cable Clamp to Secure W107 (N5245-20068)

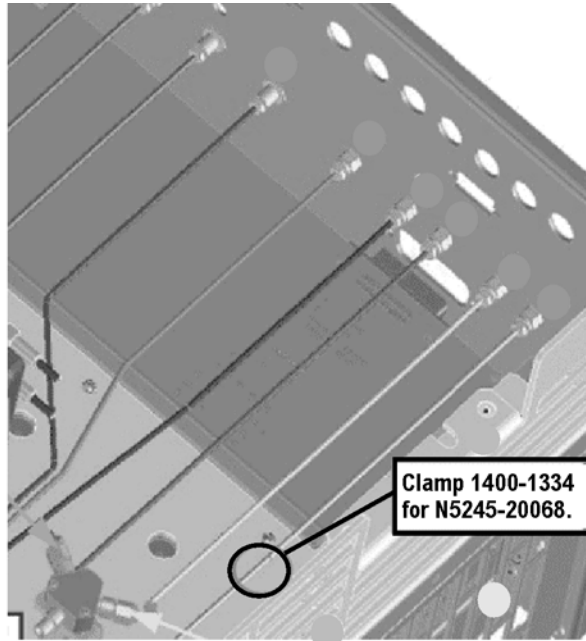

N5245_010_23

- W120 (N5245-20062) A53 port 2 mechanical switch to A32 port 2 reference coupler
- W119 (N5245-20063) A53 port 2 mechanical switch to W17
- W106 (N5245-20065) A50 port 1 mechanical switch to A29 port 1 reference coupler
- W105 (N5245-20064) A50 port 1 mechanical switch to A29 port 1 reference coupler
- W111 (N5245-20058) A51 SRC2 OUT1 mechanical switch mechanical switch to W13
- W47 (reuse) (N5245-20119) Front panel REF 2 RCVR R2 IN to A27 mixer brick (R2)
- W43 (reuse) (N5245-20009) A37 reference mixer switch to A27 mixer brick (R1)
- W110 (N5245-20067) A50 port 1 mechanical switch to A54 combiner
- W98 (reuse) (N5245-20056) A46 port 1 receiver attenuator to A27 mixer brick (A)
- W104 (reuse) (N5245-20057) A49 port 2 receiver attenuator to A27 mixer brick (B)
- W16 (N5245-20053) Front panel SRC 2 OUT 2 to W15
- W112 (N5245-20078) Front panel SRC 2 OUT 1 to A51 SRC2 OUT1 mechanical switch

Step 17. Install Rear Panel Hardware

To see an image of the rear panel assembly, click the Chapter 6 bookmark “Rear Panel Assembly, All Options” in the PDF Service Guide¹.

1. Secure seven hex nuts on the rear panel bulkhead connectors to 21 in-lbs using a 9mm nut bit.
2. Go back and re-torque the seven hex nuts to 21 in-lbs using a manual torque wrench.
3. Install the 2.4 mm 50 GHz termination (0955-2394) on J7, port 3.
4. Install three rear panel jumpers (N5245-20155) between the following connector pairs:
 - SW TSET IN (J1) and SW SRC OUT (J2)
 - COMB ARM IN (J10) and SW SRC OUT (J11)
 - COMB ARM IN (J9) and SW SRC OUT (J8)

NOTE Two hole plugs (6960-0523) remain in the rear panel.

Step 18. Reinstall the A24 IF Multiplexer Board

For instructions, click the Chapter 7 bookmark “Removing and Replacing the A24 IF Multiplexer Board” in the PDF Service Guide¹.

Step 19. Reinstall the A23 Test Set Motherboard

CAUTION Follow instructions carefully when making cable connections, especially wire harness connections. Incorrect connections can destroy components, resulting in additional customer costs.

1. For instructions on reinstalling the board, click the Chapter 7 bookmark “Removing and Replacing the A23 test set motherboard” in the PDF Service Guide¹.
2. If not already done in a previous step, install the following new wire harnesses in the order listed. To see an image showing their location, click the Chapter 6 bookmark “Bottom Ribbon Cables and Wire Harnesses, 4-Port, Option 423” in the PDF Service Guide¹. New parts are listed in [Table 1 on page 7](#).
 - Wire harness (part of mechanical switch assembly), A23 test set motherboard J101 to A50 port 1 mechanical switch
 - Wire harness (part of mechanical switch assembly), A23 test set motherboard J104 to A51 SRC2 OUT1 mechanical switch
 - Wire harness (part of mechanical switch assembly), A23 test set motherboard J102 to A53 port 2 mechanical switch

1. See [“Downloading the Online PNA Service Guide” on page 5](#).

Step 20. Replace the Lower Front Panel Overlay

Refer to [Figure 10](#) for this step of the procedure. New parts are listed in [Table 1 on page 7](#).

1. From the back side of the front panel, use a blunt object in the cutouts in the lower front dress panel to push on the old overlay (item ①) and separate it from the front dress panel.
2. From the front side of the front panel, pull off the overlay completely and discard it.
3. Remove any adhesive remaining on the front panel.
4. Remove the protective backing from the new front panel overlay, N5242-80005 (item ②).
5. Starting from either side, *loosely* place the overlay in the recess on the lower front panel, ensuring that it fits tightly against the edges of the recess.
6. Once the overlay is in place, press it firmly onto the frame to secure it.

Figure 10 Lower Front Panel Overlay Replacement

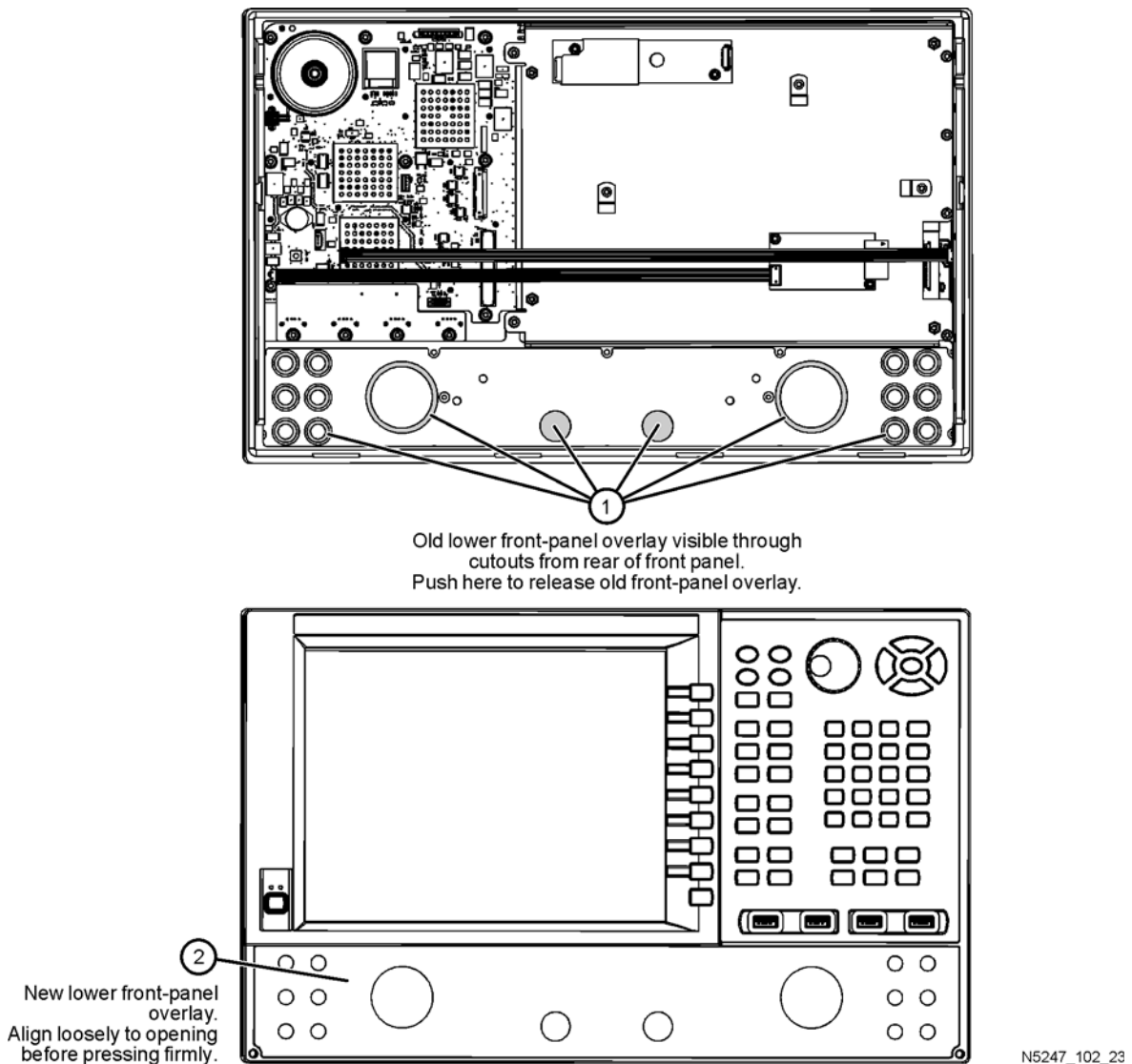

N5247_102_23

Step 21. Reinstall Front Panel Assembly

For instructions on reinstalling the front panel assembly, click the Chapter 7 bookmark “Removing and Replacing the Front Panel Assembly” in the PDF Service Guide¹.

Step 22. Position the Cables and Wires to Prevent Pinching

On the top side of the PNA, carefully position the grey flex cables so they can't be pinched between the covers and the rails.

On the bottom side of the PNA, carefully fold or push down the ribbon cables and wires so they can't be pinched between the hardware and the outer cover. Ribbon cables and wires must never be positioned on top of hardware.

Step 23. Reinstall the Inner Cover

For instructions, click the Chapter 7 bookmark “Removing the Covers” in the PDF Service Guide¹.

Step 24. Reinstall the Outer Cover

For instructions, click the Chapter 7 bookmark “Removing the Covers” in the PDF Service Guide¹.

Step 25. Enable Option 224

Procedure Requirements

- The analyzer must be powered up and operating to perform this procedure.
- The Network Analyzer program must be running.
- Obtain a license key for installation of this upgrade by following the instructions on the supplied Option Entitlement Certificate.

Option Enable Procedure

1. To start the option enable utility, press UTILITY **System**, then **Service**, then **Option Enable**. An option enable dialog box will appear.
2. Click the arrow in the **Select Desired Option** box. A list of available options will appear.
3. In the **Select Desired Option** list, click **224 - 2nd Src w/Combiner & Switches**.
4. Using the keyboard, enter the license key in the box provided. The license key is printed on the license message you received from Keysight. Enter this key *exactly* as it is printed on the message.
5. Click **Enable**.
6. Click **Yes** in answer to the displayed question in the **Restart Analyzer?** box.
7. When the installation is complete, click **Exit**.

Option Verification Procedure

1. See [“Downloading the Online PNA Service Guide” on page 5](#).

Once the analyzer has restarted and the Network Analyzer program is again running:

1. On the analyzer's **Help** menu, click **About Network Analyzer**.
2. Verify that "224" is listed after "Options:" in the display. Click **OK**.

NOTE If Option 224 has not been enabled, perform the "Option Enable Procedure" again. If the option is still not enabled, contact Keysight Technologies. Refer to "Getting Assistance from Keysight" on page 3.

Step 26. Perform Post-Upgrade Adjustments and Calibration

Adjustments

The following adjustments must be made due to the hardware changes of the analyzer.

- source adjustment
- receiver adjustment

These adjustments are described in the PNA Service Guide and in the PNA on-line HELP. A list of equipment required to perform these adjustments is also found in the service guide.

To view this service guide information, click the Chapter 3 bookmark "Tests and Adjustments" in the PDF Service Guide¹.

After the specified adjustments have been performed, the analyzer should operate and phase lock over its entire frequency range.

Operator's Check

Perform the Operator's Check to check the basic functionality of the analyzer. For instructions, click the Chapter 3 bookmark "Tests and Adjustments" in the PDF Service Guide¹.

If you experience difficulty with the basic functioning of the analyzer, contact Keysight. Refer to "Contacting Keysight" on page 3.

Calibration

Although the analyzer functions, its performance relative to its specifications has not been verified. It is recommended that a full instrument calibration be performed using the analyzer's internal performance test software. To view information on the performance test software, click the Chapter 3 bookmark "Tests and Adjustments" in the PDF Service Guide¹.

Step 27. Prepare the PNA for the User

1. If necessary, reinstall front jumper cables.
2. If necessary, reinstall the cable guards, pushing them over the front jumper cables until the cushioning material touches the front panel of the PNA.
3. Install the dust caps on the test ports.
4. Clean the analyzer, as needed, using a damp cloth.

1. See "Downloading the Online PNA Service Guide" on page 5.

This information is subject to change without notice.

© Keysight Technologies 2009 - 2014

December 1, 2014



N5245-90005
www.keysight.com