

# Keysight Add 4-Port Capability Upgrade Kit

To Upgrade PNA-X N5244A or N5245A Option 200 to Option 400

For Analyzers with Serial Numbers Prefixed MY/SG/US5150 and Below

Upgrade Kit Order Numbers: N5244AU- 940 and N5245AU- 940

Keysight Kit Number: N5245-60105

NOTICE: This document contains references to Agilent Technologies. Agilent's former Test and Measurement business has become Keysight Technologies. For more information, go to [www.keysight.com](http://www.keysight.com).



---

## WARRANTY STATEMENT

THE MATERIAL CONTAINED IN THIS DOCUMENT IS PROVIDED "AS IS," AND IS SUBJECT TO BEING CHANGED, WITHOUT NOTICE, IN FUTURE EDITIONS. FURTHER, TO THE MAXIMUM EXTENT PERMITTED BY APPLICABLE LAW, KEYSIGHT DISCLAIMS ALL WARRANTIES, EITHER EXPRESS OR IMPLIED WITH REGARD TO THIS MANUAL AND ANY INFORMATION CONTAINED HEREIN, INCLUDING BUT NOT LIMITED TO THE IMPLIED WARRANTIES OF MERCHANTABILITY AND FITNESS FOR A PARTICULAR PURPOSE. KEYSIGHT SHALL NOT BE LIABLE FOR ERRORS OR FOR INCIDENTAL OR CONSEQUENTIAL DAMAGES IN CONNECTION WITH THE FURNISHING, USE, OR PERFORMANCE OF THIS DOCUMENT OR ANY INFORMATION CONTAINED HEREIN. SHOULD KEYSIGHT AND THE USER HAVE A SEPARATE WRITTEN AGREEMENT WITH WARRANTY TERMS COVERING THE MATERIAL IN THIS DOCUMENT THAT CONFLICT WITH THESE TERMS, THE WARRANTY TERMS IN THE SEPARATE AGREEMENT WILL CONTROL.

---

## DFARS/Restricted Rights Notice

If software is for use in the performance of a U.S. Government prime contract or subcontract, Software is delivered and licensed as "Commercial computer software" as defined in DFAR 252.227-7014 (June 1995), or as a "commercial" as defined in FAR 2.101(a) or as "Restricted computer software" as defined in FAR 52.227-19 (June 1987) or any equivalent agency regulation or contract clause. Use, duplication or disclosure of Software is subject to Keysight Technologies' standard commercial license terms, and non-DOD Departments and Agencies of the U.S. Government will receive no greater than Restricted Rights as defined in FAR 52.227-19(c)(1-2) (June 1987). U.S. Government users will receive no greater than Limited Rights as defined in FAR 52.227-14 (June 1987) or DFAR 252.227-7015 (b)(2) (November 1995), as applicable in any technical data.

---

## Safety Notes

The following safety notes are used throughout this document. Familiarize yourself with each of these notes and its meaning before performing any of the procedures in this document.

---

**WARNING**      **Warning denotes a hazard. It calls attention to a procedure which, if not correctly performed or adhered to, could result in injury or loss of life. Do not proceed beyond a warning note until the indicated conditions are fully understood and met.**

---

---

**CAUTION**      Caution denotes a hazard. It calls attention to a procedure that, if not correctly performed or adhered to, could result in damage to or destruction of the instrument. Do not proceed beyond a caution sign until the indicated conditions are fully understood and met.

---

---

## Description of the Upgrade

This upgrade converts your N5244A or N5245A Option 200 2-port analyzer to a N5244A or N5245A Option 400 4-port analyzer by adding:

- an additional source
- an additional source synthesizer
- two additional doublers
- an additional mixer brick
- two additional reference couplers
- two additional test port couplers
- a splitter
- a modified front panel
- many new cables

---

## Getting Assistance from Keysight

Installing this upgrade kit requires special skills and experience. If you think you may not be qualified to do the work, or need advice, contact Keysight.

### Contacting Keysight

Assistance with test and measurements needs and information on finding a local Keysight office are available on the Web at:

<http://www.keysight.com/find/assist>

If you do not have access to the Internet, please contact your Keysight field engineer.

---

<b>NOTE</b>	In any correspondence or telephone conversation, refer to the Keysight product by its model number and full serial number. With this information, the Keysight representative can determine whether your product is still within its warranty period.
-------------	---

---

### If You Have Problems With the Upgrade Kit Contents

Keysight stands behind the quality of the upgrade kit contents. If you have problems with any item in the kit, email Keysight Component Test Division (CTD) Support at [support\\_ctd-soco@keysight.com](mailto:support_ctd-soco@keysight.com), or telephone the CTD Hotline at (707) 577-6802 and leave a voice mail message. Please include details of the problem.

---

## Getting Prepared

---

**CAUTION** The PNA contains extremely sensitive components that can be ruined if mishandled. Follow instructions carefully when making cable connections, especially wire harness connections.

The person performing the work accepts responsibility for the full cost of the repair or replacement of damaged components.

---

To successfully install this upgrade kit, you will need the following:

- A license key - refer to “[License Key Redemption](#)” below.
- A PDF copy or a paper copy of the PNA Service Guide - refer to “[Downloading the Online PNA Service Guide](#)” below.
- An ESD-safe work area - refer to “[Protecting Your Workspace from Electrostatic Discharge](#)” below.
- Correct tools - refer to “[Tools Required for the Installation](#)” on page 5.
- Enough time - refer to “[About Installing the Upgrade](#)” on page 6.
- Test equipment for the post-upgrade adjustments and full instrument calibration. To view the equipment list, click the Chapter 3 bookmark “[Tests and Adjustments](#)” in the PDF Service Guide<sup>1</sup>.

## License Key Redemption

---

**NOTE** The enclosed Option Entitlement Certificate is a receipt, verifying that you have purchased a licensed option for the PNA of your choice. You must now use a Keysight Web page to request a license key for the instrument that will receive the option.

---

To enable the option product, you must request a license key from: <http://www.keysight.com/find/softwarelicense>. To complete the request, you will need to gather the following information:

- From the certificate
  - Order number
  - Certificate number
- From your instrument
  - Model number
  - Serial number
  - Host ID

The instrument information is available on the network analyzer – on the analyzer’s **Help** menu, click **About Network Analyzer**.

If you provide an email address, Keysight will promptly email your license key. Otherwise, you will receive your license key via postal mail.

---

1. See “[Downloading the Online PNA Service Guide](#)” on page 5.

## Downloading the Online PNA Service Guide

To view the online Service Guide for your PNA model number, use the following steps:

1. Go to [www.keysight.com](http://www.keysight.com).
2. In the Search box, enter the model number of the analyzer (Ex: N5245A) and click **Search**.
3. Click **Technical Support > Manuals**.
4. Click **Service Manual**.
5. Click the service guide title to download the PDF file.
6. When the PDF of the Service Guide is displayed, scroll through the Contents section bookmarks to locate the information needed.

## Protecting Your Workspace from Electrostatic Discharge

For information, click on the Chapter 1 bookmark, “Electrostatic Discharge Protection” in the PDF Service Guide<sup>1</sup>.

### ESD Equipment Required for the Installation

Description	Keysight Part Number
ESD grounding wrist strap	9300-1367
5-ft grounding cord for wrist strap	9300-0980
2 x 4 ft conductive table mat and 15-ft grounding wire	9300-0797
ESD heel strap (for use with conductive floors)	9300-1308

### Tools Required for the Installation

Description	Qty	Part Number
T-6 TORX driver - set to 4 in-lbs (0.45 N.m)	1	N/A
T-10 TORX driver - set to 9 in-lbs (1.02 N.m)	1	N/A
T-20 TORX driver - set to 21 in-lbs (2.38 N.m)	1	N/A
5/16-in (8 mm) nutsetter or open end torque wrench - set to 10 in-lbs (1.13 N.m)	1	N/A
5/16-in (8 mm) nutsetter or open end torque wrench - set to 21 in-lbs (2.38 N.m)	1	N/A
3/16-in (5 mm) nutsetter or open end torque wrench - set to 6 in-lbs (0.68 N.m)	1	N/A
5/8-in (16 mm) nutsetter or open end torque wrench - set to 21 in-lbs (2.38 N.m)	1	N/A
9 mm nutsetter or open end torque wrench - set to 21 in-lbs (2.38 N.m)	1	N/A
1-in (25.4 mm) torque wrench - set to 72 in-lbs (8.15 N.m)	1	N/A
1/4-in (6 mm) open end wrench	1	N/A

---

**CAUTION** Use a 5/16-in torque wrench set to 10 in-lbs on all cable connections except the front and rear panel bulkhead connectors. On these, use a 9 mm nutsetter or open end torque wrench set to 21 in-lb.

---

### About Installing the Upgrade

Products affected . . . . .	N5244A and N5245A Option 200
Installation to be performed by . . . . .	Keysight service center or personnel qualified by Keysight
Estimated installation time . . . . .	.5 hours
Estimated adjustment time . . . . .	.0.5 hours
Estimated full instrument calibration time . . . . .	4.5 hours

## Items Included in the Upgrade Kit

Check the contents of your kit against the following list. If any part is missing or damaged, contact Keysight Technologies. Refer to [“Getting Assistance from Keysight” on page 3](#).

**Table 1 Contents of Upgrade Kit N5245-60105**

Ref Desig.	Description	Qty	Part Number
-	Installation note (this document)	1	N5245-90015
A10	26.5 GHz source (2) assembly	1	5087-7780 Was 5087-7327
A12	Doubler assembly, port 3	2	5087-7349 Was 5087-7318
A13	Doubler assembly, port 4		
A17	13.5 GHz source 2 synthesizer board <sup>a</sup>	3	N5240-60076 Was N5242-60166
A28	Mixer brick (2)	1	5087-7323
A30	Test port 3 reference coupler	2	5087-7760 Was 5086-7658
A31	Test port 4 reference coupler		
A34	Test port 3 coupler	2	5087-7793 Was 5087-7724
A35	Test port 4 coupler		
A26	Splitter	1	5067-4086 Was 5086-7408
A69	3 dB pad, attached to R4 connector on A28 mixer brick	1	08490-60010
-	Front frame, diecast, 4-port	1	N5247-20141 Was N5245-20128
-	Machine screw, M3.0 x 6, flat head (to attach lower front dress panel to the test set front plate)	4	0515-1227
-	Machine screw, M2.0 x 6, flat head (to attach 2 reference couplers to brackets)	8	0515-1602
-	Machine screw, M3.0 x 25, pan head (to attach mixer brick A28 to mounting block)	3	0515-0667
-	Machine screw, M4.0 x 10, pan head (2 to attach source 2 assy to chassis; 2 to attach A12 doubler 3 to chassis; 2 to attach A13 doubler 4 to chassis)	6	0515-0380
-	Machine screw, M3.0 x 8, pan head (3 to attach shield to mixer brick; 1 to attach cable bracket to deck)	4	0515-0372
-	Machine screw, M2.5 x 16, pan head (to attach splitter to mixer brick)	2	0515-2007
-	Machine screw, M3.0 x 6, pan head (to attach 2 reference coupler/bracket assemblies to deck)	4	0515-0430
-	Front panel overlay (label), 4-port	1	N5242-80003
-	Test set front plate, 4-port	1	N5224-00005
-	Nameplate, N5244A	1	N5244-80001
-	Nameplate, N5245A	1	N5245-80003
-	Gap pad (between each coupler and test set front sub panel)	4	E4403-20033
-	Gap pad (between mixer brick A28 and shield)	4	N5245-20125



**Table 1 Contents of Upgrade Kit N5245-60105**

Ref Desig.	Description	Qty	Part Number
-	Power button overlay (label)	1	N5242-80007
-	Keypad overlay (label)	1	N5242-80005
-	Shield, mixer brick	1	N5245-00023
-	50 ohm load (attach to W58 (N5245-20095))	1	1810-0118
-	Vibration mount (between couplers 1 & 3, and 2 & 4)	2	0460-2725
-	Mounting nuts (for port 3 & 4 test port couplers)	2	5022-1087
-	Cable guard, center jumper cables	1	N5242-00030
-	Bracket for reference coupler	2	N5245-00017
-	Bracket for cables	1	N5245-00022
-	Cable clamp, to secure W35 (N5245-20108), W29 (N5245-20017), W21 (N5245-20110), and W25 (N5245-20016)	8	1400-1334
-	Cable ties, to secure W38 (N5245-20037) and W44 (N5245-20020) together	5	1400-0249
-	Dust caps for test ports	4	1401-0214
W2	A10 (source 2) P1 to A17 13.5 GHz source (2) synthesizer J1207	1	N5245-20100
W7	A10 (source 2) P5 to A12 port 3 doubler	1	N5245-20034
W8	A10 (source 2) P3 to A13 port 4 doubler	1	N5245-20035
W9	A10 (source 2) P4 to A12 port 3 doubler	1	N5245-20032
W10	A12 port 3 doubler to A13 port 4 doubler	1	N5245-20033
W13	A12 port 3 doubler to W14	1	N5245-20036
W14	A30 port 3 reference coupler to W13	1	N5245-20043
W15	A13 port 4 doubler to W16	1	N5245-20036
W16	A31 port 4 reference coupler to W15	1	N5245-20044
W20	A33 port 1 coupler to Port 1 CPLR THRU	1	N5245-20099
W21	A29 port 1 reference coupler to A37 reference mixer switch	1	N5245-20110
W22	A33 port 1 coupler to front-panel Port 1 CPLR ARM	1	N5245-20014
W23	A30 port 3 ref coupler to front-panel Port 3 SOURCE OUT	1	N5245-20051
W24	A34 port 3 coupler to front-panel Port 3 CPLR THRU	1	N5245-20098
W25	A30 port 3 ref coupler to front-panel REF 3 SOURCE OUT	1	N5245-20016
W26	A34 port 3 coupler to front-panel Port 3 CPLR ARM	1	N5245-20015
W27	A31 port 4 ref coupler to front-panel Port 4 SOURCE OUT	1	N5245-20052
W28	A35 port 4 coupler to front-panel Port 4 CPLR THRU	1	N5245-20096
W29	A31 port 4 ref coupler to front-panel REF 4 SOURCE OUT	1	N5245-20017
W30	A35 port 4 coupler to front-panel Port 4 CPLR ARM	1	N5245-20018
W32	A36 port 2 coupler to front-panel Port 2 CPLR THRU	1	N5245-20097
W34	A36 port 2 coupler to front-panel Port 2 CPLR ARM	1	N5245-20019
W35	A32 port 2 reference coupler to front-panel REF 2 SOURCE OUT	1	N5245-20108
W36	Front panel jumper	6	N5245-20155 Was N5245-20104

**Table 1 Contents of Upgrade Kit N5245-60105**

Ref Desig.	Description	Qty	Part Number
W38	Port 3 RCVR C IN to A28 mixer brick (C)	1	N5245-20037
W39	Port 4 RCVR D IN to A28 mixer brick (D)	1	N5245-20038
W44	REF 3 RCVR R3 IN to A28 mixer brick (R3)	1	N5245-20020
W45	REF 4 RCVR R4 IN to A69 3 dB pad on A28 mixer brick (R4)	1	N5245-20021
W52	A25 HMA26.5 to A26 splitter	1	N5245-20013
W53	A26 splitter to A27 mixer brick	1	N5245-20023
W54	A26 splitter to A28 mixer brick	1	N5245-20022
W58	A28 mixer brick to 50 ohm load (1810-0118)	1	N5245-20095
W62	A27 mixer brick (R1) to A24 IF multiplexer (P411)	1	N5242-60021
W63	A27 mixer brick (R2) to A24 IF multiplexer (P412)	1	N5242-60022
W65	A28 mixer brick (D) to A24 IF multiplexer (P801)	1	N5242-60024
W66	A28 mixer brick (R4) to A24 IF multiplexer (P414)	1	N5242-60019
W67	A28 mixer brick (R3) to A24 IF multiplexer (P413)	1	N5242-60020
W68	A28 mixer brick (C) to A24 IF multiplexer (P601)	1	N5242-60023
W70	A20 IF multiplexer (P203) to A12 SPAM (J2)	1	N5242-60013
W72	A20 IF multiplexer (P603) to A12 SPAM (J5)	1	N5242-60015
W77	A14 frequency reference (J7) to A17 13.5 GHz (source 2) synth (J5)	1	N5242-60030
-	Wire assembly, A23 test set motherboard J221 to ports 1/3 LED board J1	2	N5225-60001
-	Wire assembly, A23 test set motherboard J222 to ports 2/4 LED board J1		
-	Ribbon cable, A23 test set motherboard J552 to A28 mixer brick (2) J52	1	N5247-60015

- a. The three 13.5 GHz Synthesizer boards included in this kit are the RoHS compliant N5240-60076 boards. These new boards are not compatible with the old N5230-60002 13.5 GHz Synthesizer boards. If the boards installed in your PNA are the old N5230-60002, you must replace ALL of them with the N5240-60076 boards included in this kit - refer to your PNA Service Guide's chapter 7 for instructions. If your PNA already contains the new boards, scrap the two extra N5240-60076 boards included in this kit.

For the new N5240-60076 boards to function properly in your PNA, you must upgrade your PNA firmware to rev A09.33xx or above. Download PNA firmware at: <http://na.support.keysight.com/pna/firmware/firmware.html>.

---

**NOTE** Extra quantities of items such as protective plastic caps, screws, cable ties, and cable clamps may be included in this upgrade kit. It is normal for some of these items to remain unused after the upgrade is completed.

---

---

## Installation Procedure for the Upgrade

The network analyzer must be in proper working condition prior to installing this option. Any necessary repairs must be made before proceeding with this installation.

---

**WARNING**      **This installation requires the removal of the analyzer's protective outer covers. The analyzer must be powered down and disconnected from the mains supply before performing this procedure.**

---

### Overview of the Installation Procedure

- Step 1. Obtain a Keyword and Verify the Information.
- Step 2. Remove the Outer Cover.
- Step 3. Remove the Inner Cover.
- Step 4. Remove the Front Panel Assembly.
- Step 5. Remove the A23 Test Set Motherboard.
- Step 6. Remove Some Cables.
- Step 7. Remove the A27 Mixer Brick Assembly.
- Step 8. Assemble the A28 Mixer Brick Assembly.
- Step 9. Install the A27/A28 Mixer Bricks Assembly.
- Step 10. Assemble the A30 and A31 Reference Coupler Assemblies.
- Step 11. Install the A30 and A31 Reference Coupler Assemblies.
- Step 12. Assemble the A33 - A36 Test Port Coupler Assemblies.
- Step 13. Install the LED Boards and Test Port Coupler Assemblies to the Test Set Front Plate.
- Step 14. Install the Coupler Plate Assembly to the Deck.
- Step 15. Assemble the A10 26.5 GHz Source 2 Assembly.
- Step 16. Assemble and Install the A12 and A13 Doubler Assemblies.
- Step 17. Install the A10 26.5 GHz Source 2 Assembly and Cables.
- Step 18. Install the A17 13.5 GHz (Source 2) Synthesizer Board and Cables.
- Step 19. Install the Test Set Cables.
- Step 20. Secure the Front Panel Bulkhead Connectors.
- Step 21. Reinstall the A23 Test Set Motherboard.
- Step 22. Disassemble the 2-Port Front Panel and Assemble the 4-Port Front Panel.
- Step 23. Reinstall Front Panel Assembly.
- Step 24. Install the Overlays.
- Step 25. Install the Front Panel Jumper Cables.

Step 26. Position the Cables and Wires to Prevent Pinching.

Step 27. Reinstall the Inner Cover.

Step 28. Reinstall the Outer Cover.

Step 29. Enable Option P04 (400).

Step 30. Perform Post-Upgrade Adjustments and Calibration.

Step 31. Prepare the PNA for the User.

## **Step 1. Obtain a Keyword and Verify the Information**

Follow the instructions on the Option Entitlement Certificate supplied to obtain a license key for installation of this upgrade. Refer to [“License Key Redemption” on page 4](#).

Verify that the model number, serial number, and option number information on the license key match those of the instrument on which this upgrade will be installed.

If the model number, serial number, or option number do not match those on your license key, you will not be able to install the option. If this is the case, contact Keysight for assistance before beginning the installation of this upgrade. Refer to [“Contacting Keysight” on page 3](#).

Once the license key has been received and the information verified, you can proceed with the installation at step 2.

## **Step 2. Remove the Outer Cover**

For instructions, click the Chapter 7 bookmark “Removing the Covers” in the PDF Service Guide<sup>1</sup>.

## **Step 3. Remove the Inner Cover**

For instructions, click the Chapter 7 bookmark “Removing the Covers” in the PDF Service Guide<sup>1</sup>.

## **Step 4. Remove the Front Panel Assembly**

For instructions, click the Chapter 7 bookmark “Removing and Replacing the Front Panel Assembly” in the PDF Service Guide<sup>1</sup>.

## **Step 5. Remove the A23 Test Set Motherboard**

For instructions, click the Chapter 7 bookmark “Removing and Replacing the A23 test set motherboard” in the PDF Service Guide<sup>1</sup>.

---

1. See [“Downloading the Online PNA Service Guide” on page 5](#).

## Step 6. Remove Some Cables

---

**NOTE** Leave the gray flexible cables, the wire harnesses, and the ribbon cables connected where possible. **Any that are removed should be labeled for reconnection later.**

---

**CAUTION** Be careful not to damage the center pins of the semirigid cables. Some flexing of the cables may be necessary but do not over-bend them.

---

**NOTE** When removing a cable, also remove the plastic cable clamp, if present. It is normal for some of the cable clamp's adhesive to remain.

---

1. Place the analyzer bottom-side up on a flat surface.
2. Remove and discard the following gray flexible cables:
  - W130 A20 IF multiplexer (P203) to A12 SPAM (J5)
  - W129 A20 IF multiplexer (P603) to A12 SPAM (J2)
3. Remove all bottom-side (test set) semirigid cables except for those in the following table. Do not discard the cables that are removed because some will be reused later in the procedure.  
To see an image showing the location of cables W11, W17, and W51 click the Chapter 6 bookmark "Top Cables, All Cables - All Options" in the PDF Service Guide<sup>1</sup>. To see an image showing the location of cables W55, W56, and W57, click the Chapter 6 bookmark "Bottom RF Cables, 2-Port, Option 200" in the PDF Service Guide<sup>1</sup>.

Reference Designator	Type <sup>a</sup>	Part Number	Qty	Description
W11	SR	N5245-20036	1	A7 port 1 doubler to W12
W17	SR	N5245-20036	1	A8 port 2 doubler to W18
W51	SR	N5245-20101	1	A15 13.5 GHz (LO) synthesizer board J1207 to A25 HMA26.5
W55	SR	N5245-20102	1	A7 port 1 doubler to W56
W56	SR	N5245-20103	1	W55 to rear-panel EXT TSET DRIVE RF OUT (J6)
W57	SR	N5245-20012	1	A27 mixer brick to EXT TSET DRIVE LO OUT (J5)

a. SR = semirigid coaxial cable.

4. Remove and discard the following gray flexible cables:
  - W62 (N5242-60025) A27 mixer brick (R1) to A24 IF multiplexer (P601)
  - W63 (N5242-60026) A27 mixer brick (R2) to A24 IF multiplexer (P801)
5. Leave the remaining gray flexible cables, the wire harnesses, and the ribbon cables connected where possible. Any that are removed should be labeled for reconnection later.

## Step 7. Remove the A27 Mixer Brick Assembly

Remove the A27 mixer brick assembly from the PNA. For instructions, click the Chapter 7 bookmark, "Removing and Replacing the A27 and A28 Mixer Bricks" in the PDF Service Guide<sup>1</sup>.

## Step 8. Assemble the A28 Mixer Brick Assembly

1. Follow the two instructions shown in [Figure 1](#). New parts are listed in [Table 1 on page 7](#) of this document.

**Figure 1 A28 Mixer Brick Assembly**



① Install A28 mixer brick 5087-7323. Secure with screws 0515-0667. Torque to 9 in-lbs.

② Add Gap pads N5245-20125 X4 to mixer brick as shown.

Not necessary to remove A27 mixer brick shield as shown.

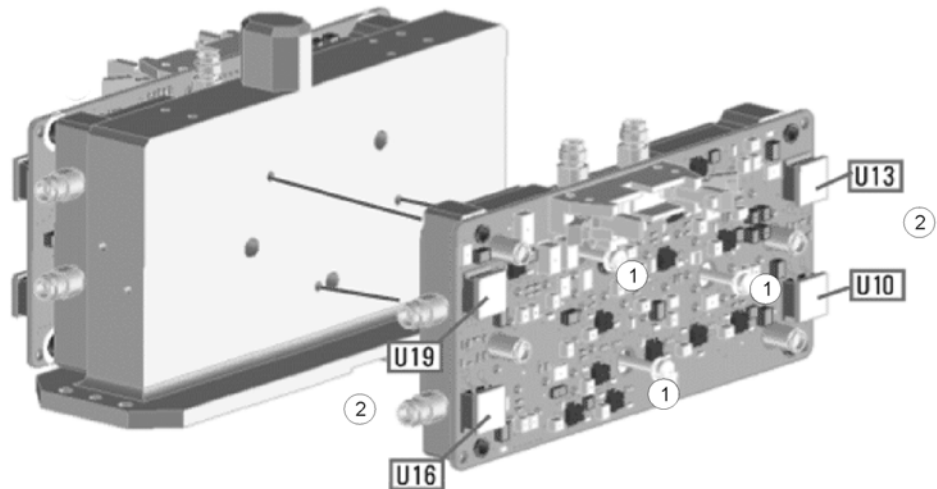

N5245\_015\_17

1. See ["Downloading the Online PNA Service Guide"](#) on page 5.

2. Follow the four instructions shown in **Figure 2**.

**Figure 2 Shields, Splitter, and 3 dB Pad Installation**

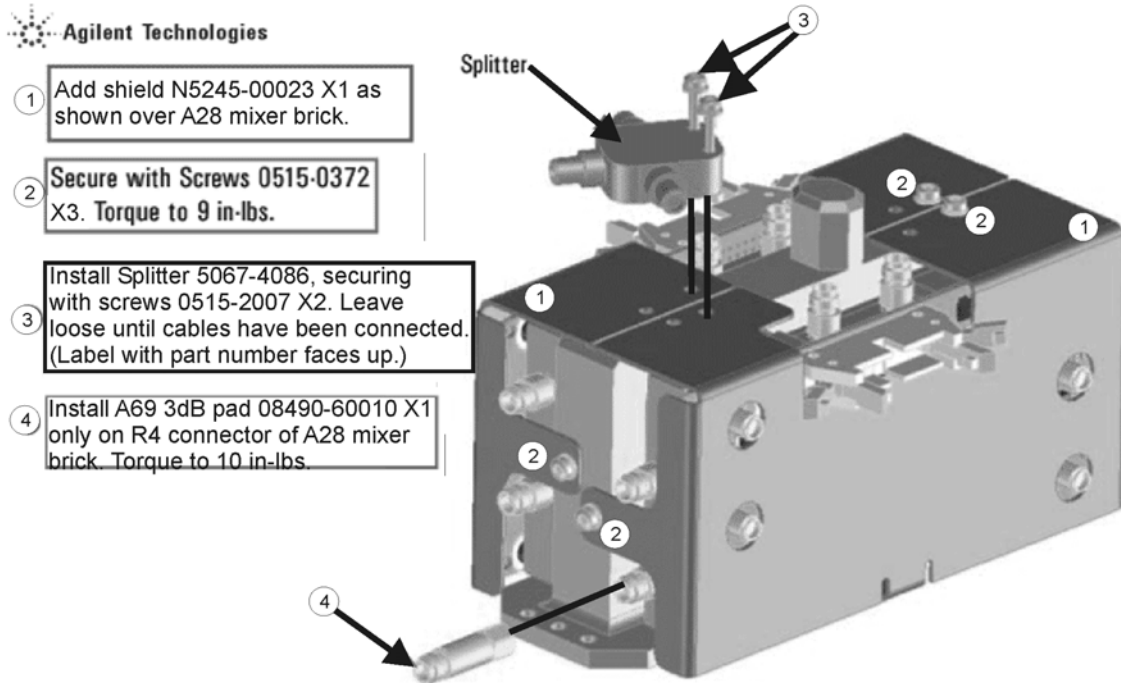

N5245\_015\_18

3. Connect the gray flexible cables in the order shown in **Figure 3**.

---

**NOTE** Graphics in this document such as **Figure 3** use very brief text to instruct where to connect a cable. For example, text that reads "N5242-60018 IFMUX P201 - BRK1 B" means to connect the N5242-60018 gray flexible cable at the A24 IF MUX board connector P201 and at A27 Mixer Brick 1 connector B.

---

**Figure 3 A28 Mixer Brick Cable Installation**

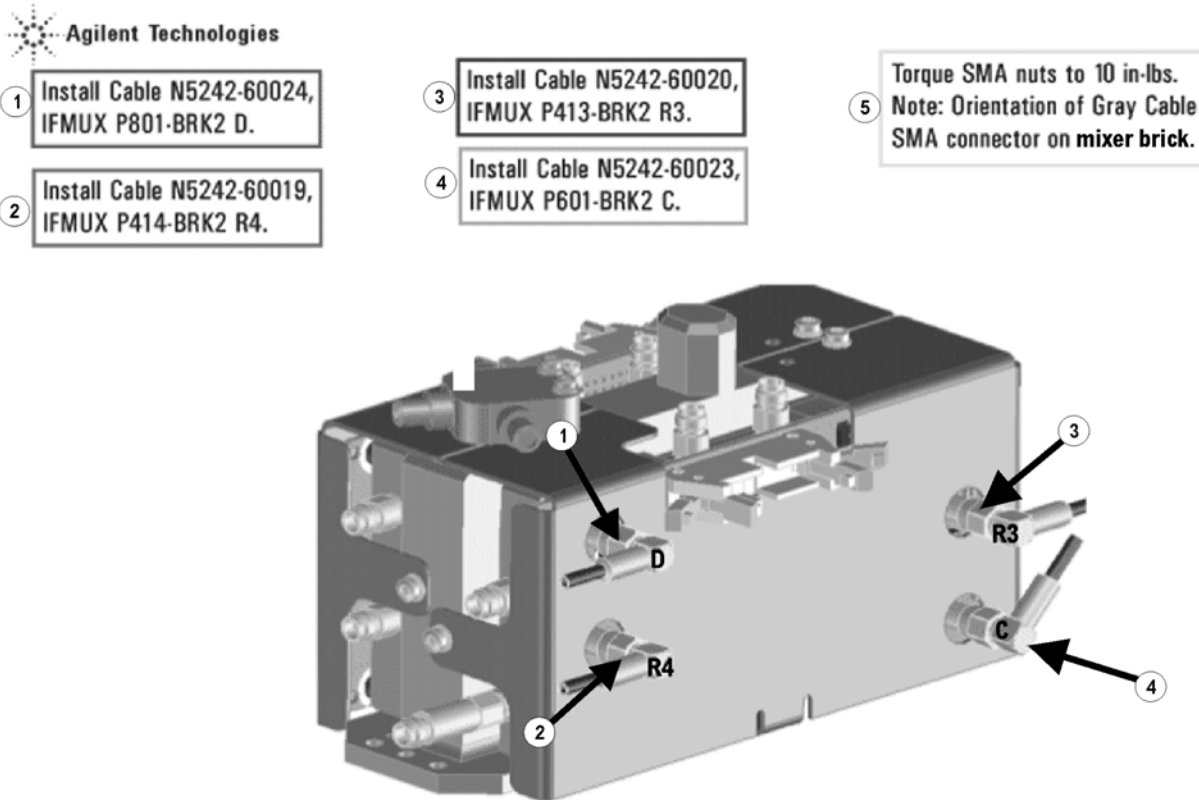

N5245\_015\_19



### Step 9. Install the A27/A28 Mixer Bricks Assembly

Install the A27/A28 mixer brick assembly, reusing the 4 existing screws. For instructions, click the Chapter 7 bookmark, "Removing and Replacing the A27 and A28 Mixer Bricks" in the PDF Service Guide<sup>1</sup>. New parts are listed in [Table 1 on page 7](#) of this document.

### Step 10. Assemble the A30 and A31 Reference Coupler Assemblies

Follow the instruction shown in [Figure 4](#). New parts are listed in [Table 1 on page 7](#) of this document.

**Figure 4** A30 and A31 Reference Coupler Assembly

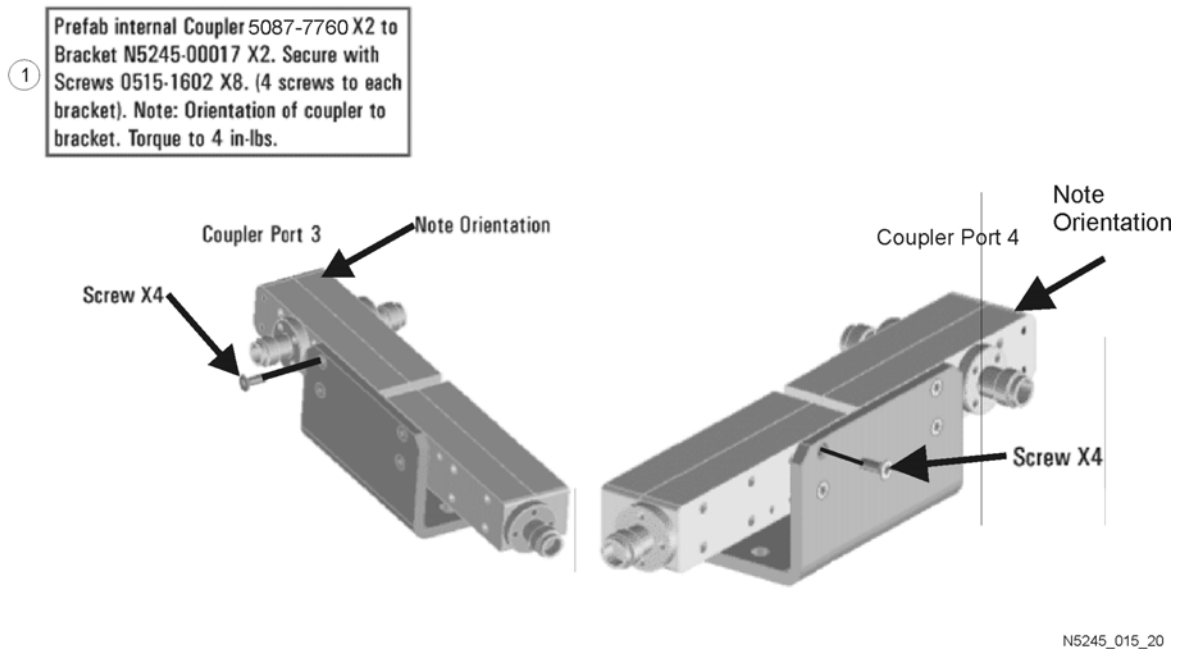

### Step 11. Install the A30 and A31 Reference Coupler Assemblies

Install the A30 and A31 reference coupler assemblies. For instructions, click the Chapter 7 bookmark, "Removing and Replacing the A29-A32 Reference Couplers and Reference Coupler Mounting Brackets" in the PDF Service Guide<sup>1</sup>. New parts are listed in [Table 1 on page 7](#) of this document.

1. See "Downloading the Online PNA Service Guide" on page 5.

## Step 12. Assemble the A33 - A36 Test Port Coupler Assemblies

1. Remove the A33 test port 1 coupler and A36 test port 2 coupler from the PNA. For instructions, click the Chapter 7 bookmark, "Removing and Replacing the A33 - A36 Test Port Couplers" in the PDF Service Guide<sup>1</sup>.
2. Using pliers, remove the adhesive bumper on the A33 test port 1 coupler and on the A36 test port 2 coupler.
3. Follow the two instructions shown in Figure 5. New parts are listed in Table 1 on page 7 of this document.

Figure 5 A33 - A36 Test Port Coupler Assembly

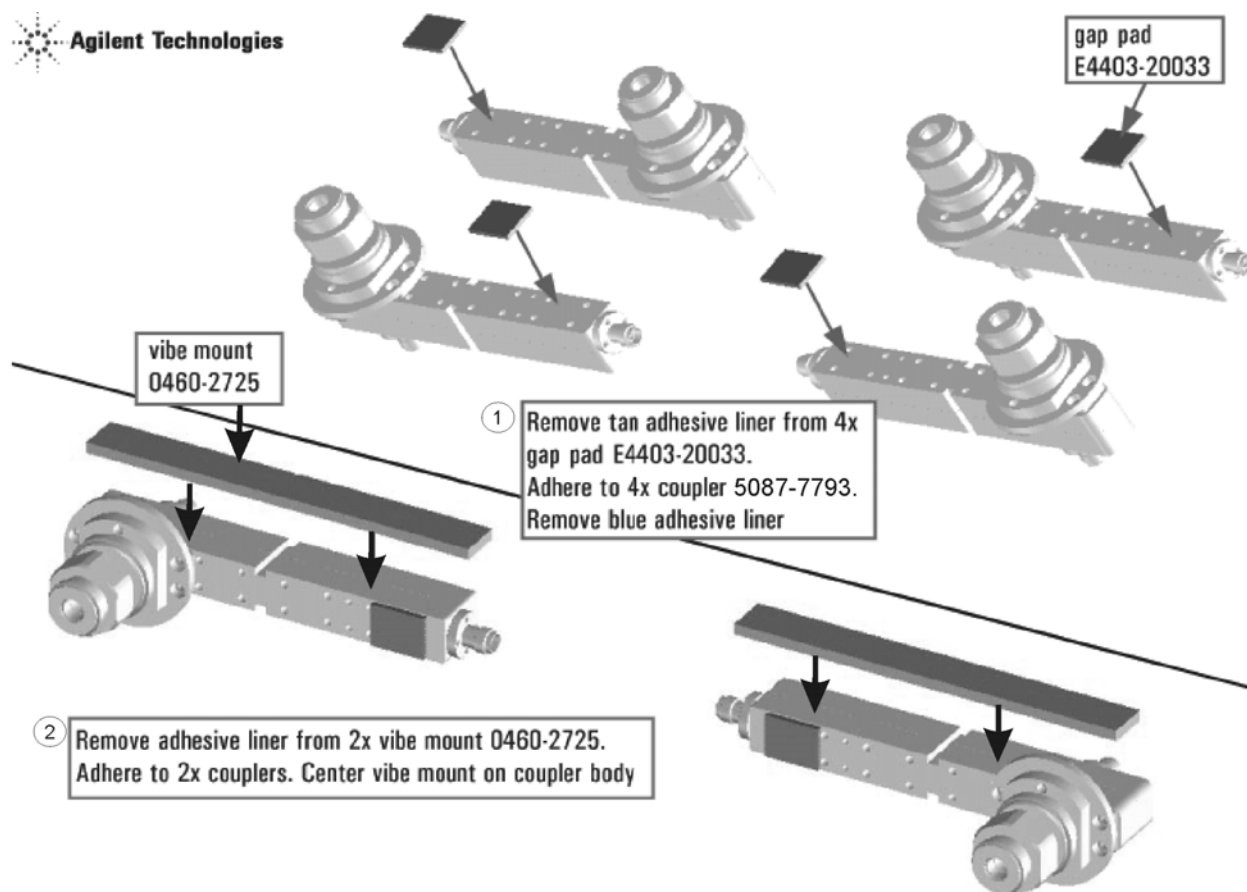

N5245\_013\_11

1. See "Downloading the Online PNA Service Guide" on page 5.

### Step 13. Install the LED Boards and Test Port Coupler Assemblies to the Test Set Front Plate

1. Remove two screws from each LED board and remove the boards from the 2-port test set front plate of the PNA.
2. Remove the 2-port test set front plate from the test set deck.
3. Follow the instructions shown in **Figure 6**.

**Figure 6 LED Board Assemblies and Test Port Coupler Assemblies Installation**

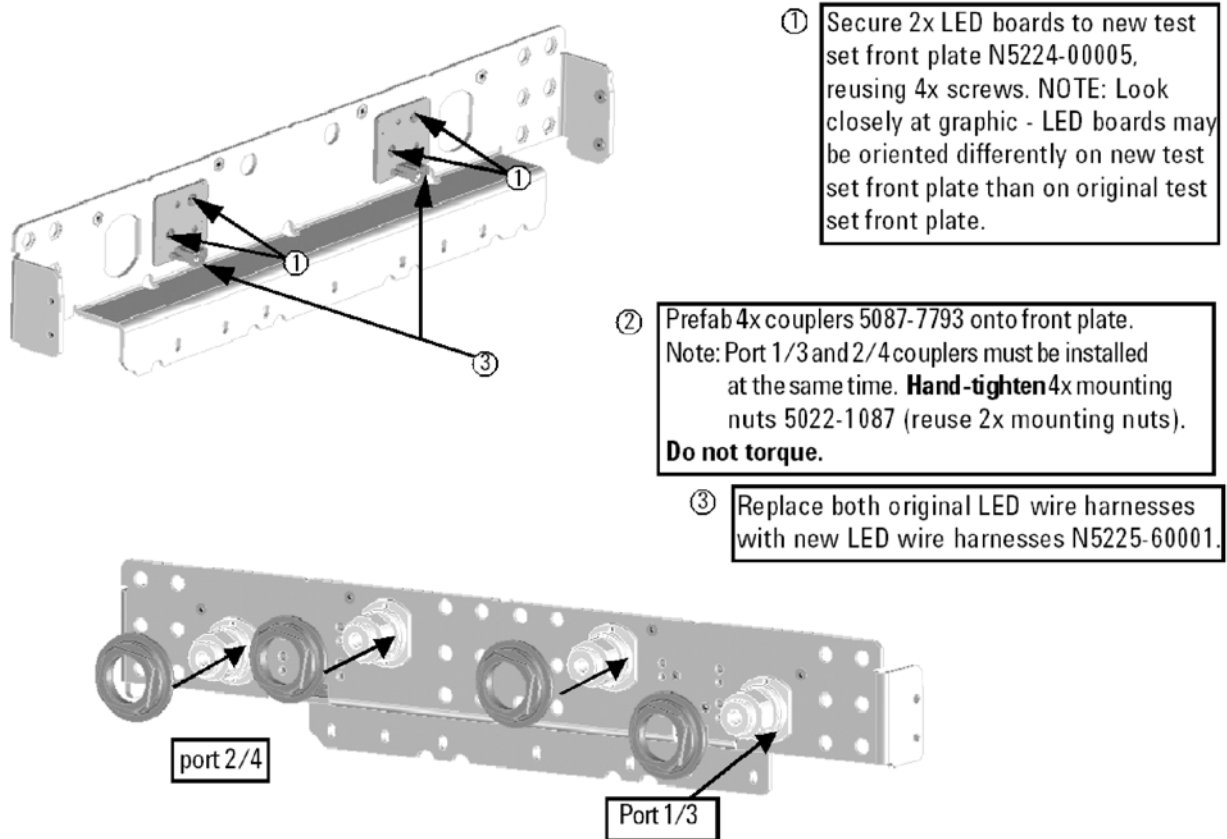

N5245\_015\_12

## Step 14. Install the Coupler Plate Assembly to the Deck

Follow the four instructions shown in [Figure 7](#).

**Figure 7** Coupler Plate Assembly Installation



- Reuse screws
- 1 Install coupler plate assy to deck. Hand-tighten 4x screws 0515-0372. Do not torque.
  - 2 Reuse screws  
Install 4x screws 0515-1227 @ 9 in-lbs.  
Alternate sides in torque sequence.
  - 3 Torque the 4x screws in step 1 to 9 in-lbs.
  - 4 Torque 4x coupler mounting nuts to 72 in-lbs.

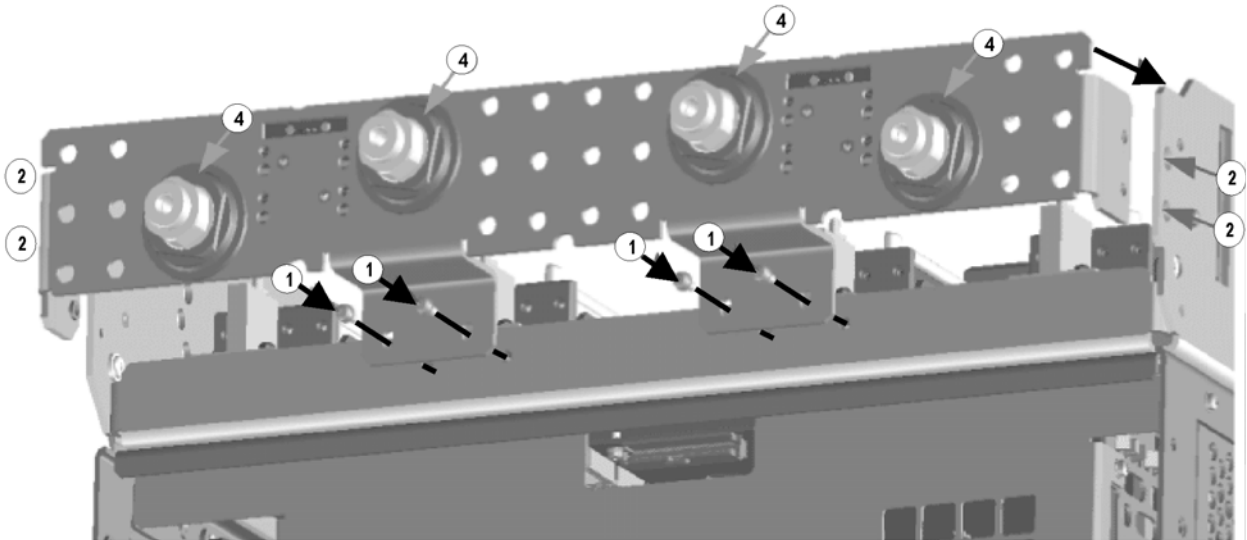

N5245\_015\_13

## Step 15. Assemble the A10 26.5 GHz Source 2 Assembly

Follow the four instructions shown in **Figure 8**.

**Figure 8** A10 Source 2 Assembly



① Gather Source 5087-7780.

② Remove 50 ohm load - keep to install later on doubler #4. Install cable N5245-20032. Torque to 10 in-lbs.

③ Install Rigid Cable N5245-20034, Torque to 10 in-lbs

④ Install Rigid Cable N5245-20035, Torque to 10 in-lbs.

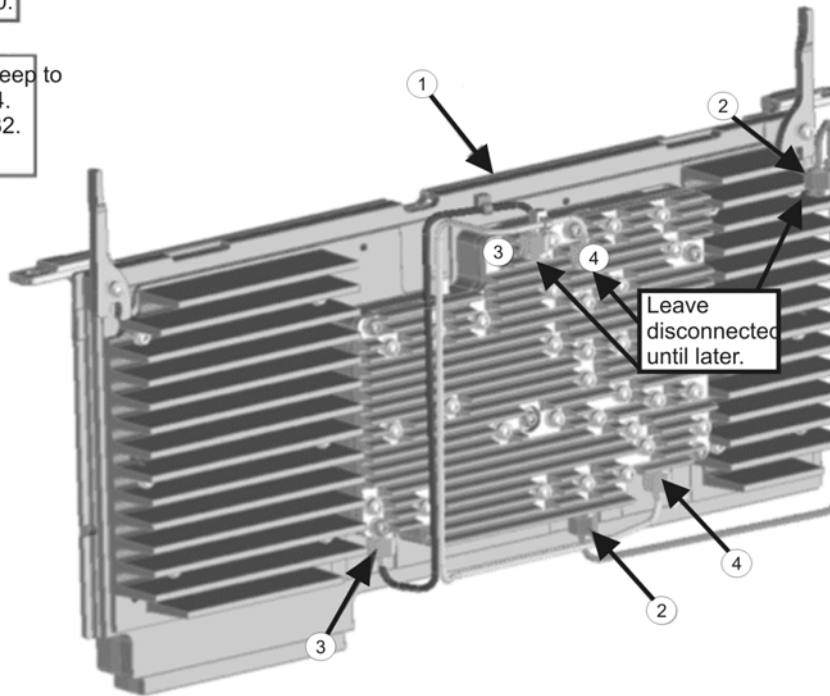

N5245\_016\_38

## Step 16. Assemble and Install the A12 and A13 Doubler Assemblies

Follow the four instructions shown in [Figure 9](#).

**Figure 9** A12 and A13 Doubler Assemblies Installation

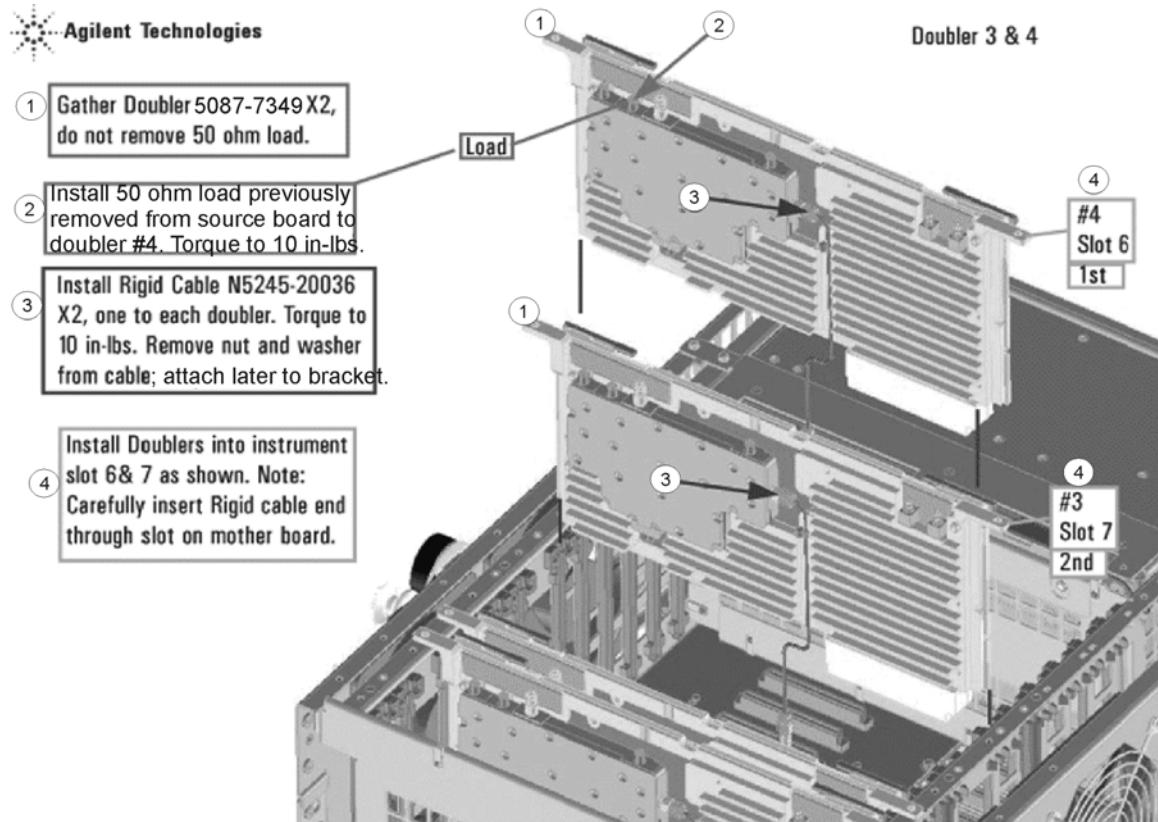

N5245\_015\_37

## Step 17. Install the A10 26.5 GHz Source 2 Assembly and Cables

Follow the four instructions shown in [Figure 10](#).

**Figure 10** A10 Source 2 Assembly Installation

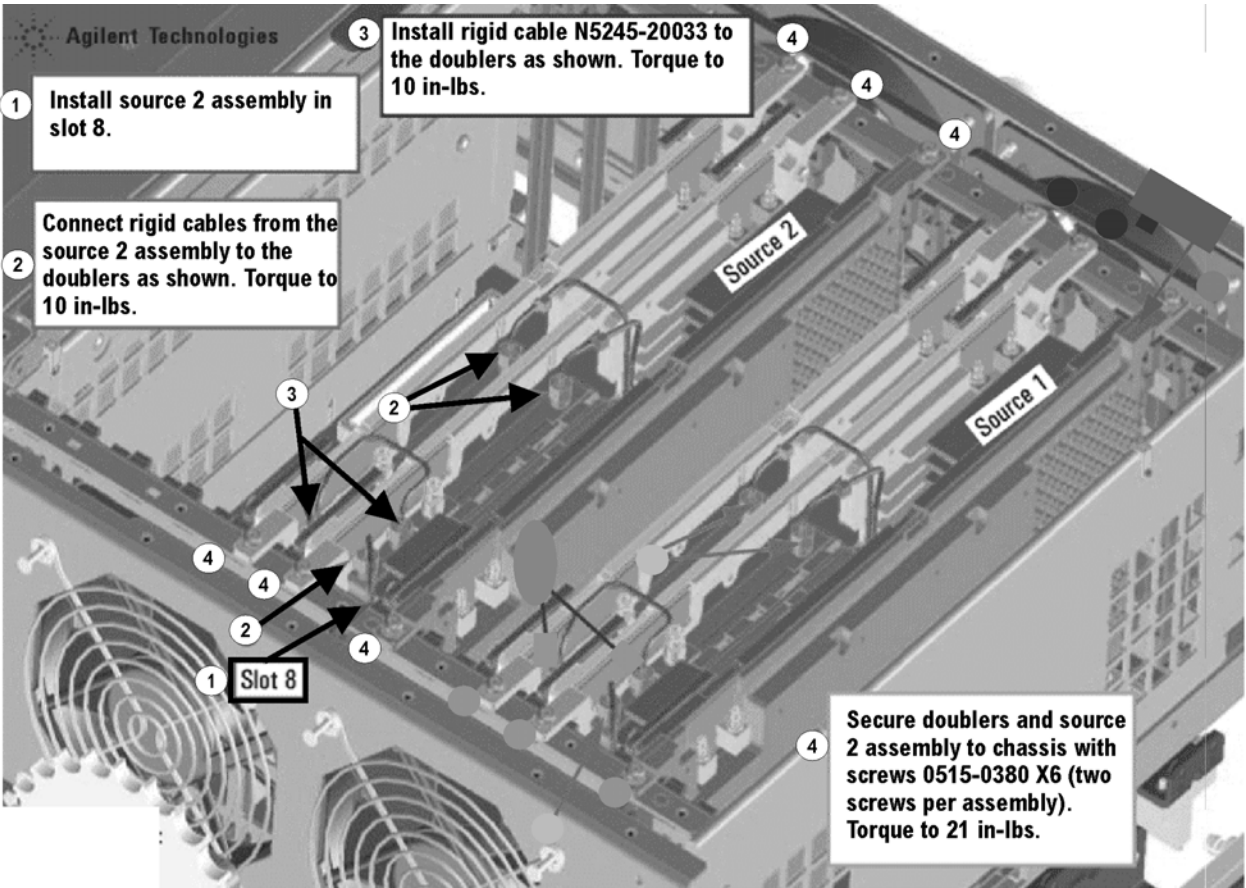

N5245\_015\_39



## Step 18. Install the A17 13.5 GHz (Source 2) Synthesizer Board and Cables

1. Install gray cable W67 (N5242-60030) to connector J5 of the A17 (source 2) synthesizer board (N5230-60002). The loose end of the cable will be connected on the A14 frequency reference board (J7) after the A17 board has been installed in the analyzer.
2. Install the A17 board into slot 2 in the motherboard. To see an image showing the location of the A17 board in the motherboard, click the Chapter 6 bookmark "Top Assemblies, All Options" in the PDF Service Guide<sup>1</sup>.
3. Connect cable W2 (N5245-20100) between the A10 source 2 board and the A17 (source 2) synthesizer board, positioning the cable in the wire looms. Tighten the cable connectors to 10 in-lbs using a 5/16-in torque wrench.
4. Connect the loose end of new gray flex cable W22 (N5242-60030) on the A14 frequency reference board (J7). (The other end of this cable was previously connected to J5 of the source 2 synthesizer board.)

---

**NOTE** The three 13.5 GHz Synthesizer boards included in this kit are the RoHS compliant N5240-60076 boards. These new boards are not compatible with the old N5230-60002 13.5 GHz Synthesizer boards. If the boards installed in your PNA are the old N5230-60002, you must replace ALL of them with the N5240-60076 boards included in this kit - refer to your PNA Service Guide's chapter 7 for instructions. If your PNA already contains the new boards, scrap the two extra N5240-60076 boards included in this kit.

For the new N5240-60076 boards to function properly in your PNA, you must upgrade your PNA firmware to rev A09.33xx or above. Download PNA firmware at:  
<http://na.support.keysight.com/pna/firmware/firmware.html>.

---

1. See "Downloading the Online PNA Service Guide" on page 5.



## Step 19. Install the Test Set Cables

---

**CAUTION** Follow instructions carefully when making cable connections, especially wire harness connections. Incorrect connections can destroy components, resulting in additional customer costs.

---

---

**CAUTION** Be careful not to damage the center pins of the semirigid cables. Some flexing of the cables may be necessary but do not over-bend them.

---

---

**CAUTION** Use a 5/16-in torque wrench set to 10 in-lbs on all cable connections except the front and rear panel bulkhead connectors. On these, use a 9 mm nutsetter or open end torque wrench set to 21 in-lb.

---

### Flexible Cables Required for Upgrading to an Option 400 PNA

Install the following flexible cables in the order listed. To see images showing the location of these cables, click either of the Chapter 6 bookmarks “Bottom RF Cables, 4-Port, Option 400” in the PDF Service Guide<sup>1</sup>. New parts are listed in [Table 1 on page 7](#).

- W62 (N5242-60021) A27 mixer brick (R1) to A24 IF multiplexer (P411)
- W63 (N5242-60022) A27 mixer brick (R2) to A24 IF multiplexer (P412)

### Semirigid Cables Required for Upgrading to an Option 400 PNA

To see images showing the location of these cables, click the Chapter 6 bookmark “Bottom RF Cables, 4-Port, Option 400” in the PDF Service Guide<sup>1</sup>. New parts are listed in [Table 1 on page 7](#).

- Follow the two instructions shown in [Figure 11](#) in this document.

---

1. See [“Downloading the Online PNA Service Guide” on page 5](#).

**Figure 11 Semirigid Cables Installation**

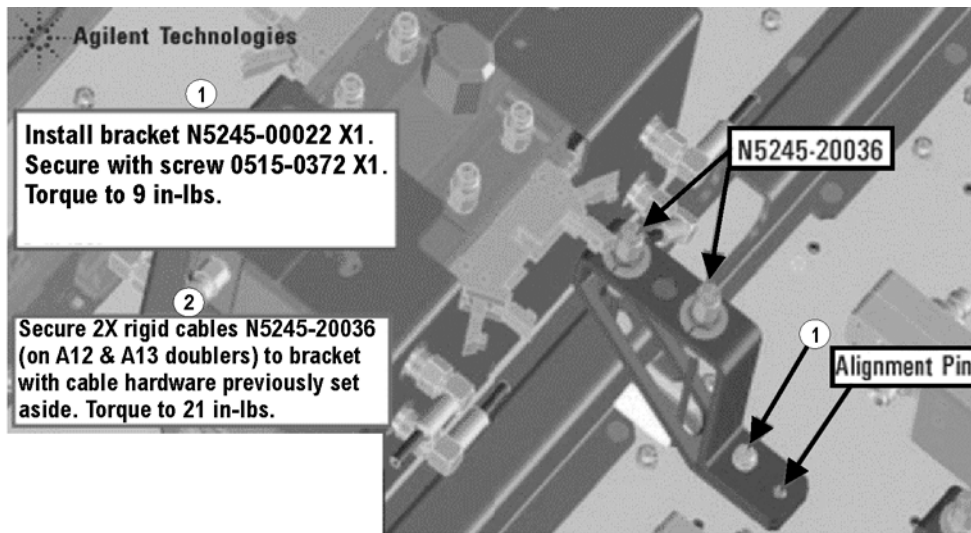

N5245\_015\_32

- W35 (N5245-20108)A32 port 2 ref coupler to front-panel REF 2 SOURCE OUT  
 \* As shown in **Figure 12**, install two clamps (part number 1400-1334) to secure W35 (N5245-20108).

**Figure 12** Location of Cable Clamps for W35 (N5245-20108)

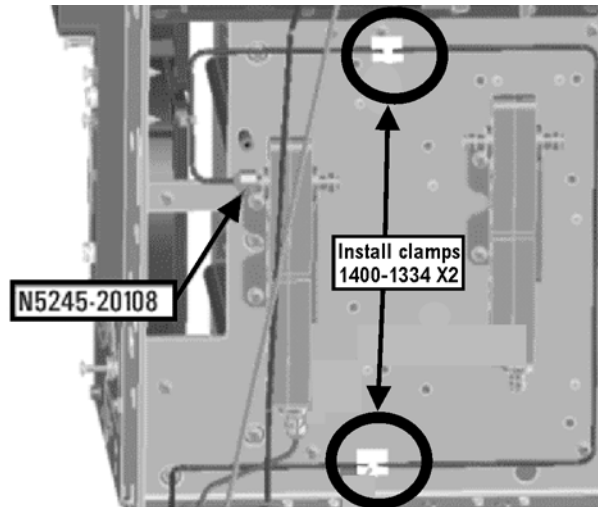

N5245\_015\_33

- W34 (N5245-20019)A36 port 2 coupler to front-panel Port 2 CPLR ARM
- W40 (reuse) (N5245-20042)Port 2 RCVR B IN to A27 mixer brick (B)
- W31 (reuse) (N5245-20040)A32 port 2 ref coupler to front-panel port 2 SOURCE OUT
- W32 (N5245-20097)Port 2 CPLR THRU to A36 port 2 coupler
- W46 (reuse) (N5245-20011)REF 2 RCVR R2 IN to A27 mixer brick (R2)
- W45 (N5245-20021)REF 4 RCVR R4 IN to A69 3 dB pad on A28 mixer brick (R4)
- W30 (N5245-20018)A35 port 4 coupler to front-panel port 4 CPLR ARM
- W39 (N5245-20038)Port 4 RCVR D IN to A28 mixer brick (D)
- W27 (N5245-20052)A31 port 4 ref coupler to front-panel Port 4 SOURCE OUT
- W28 (N5245-20096)Port 4 CPLR THRU to A35 port 4 coupler

- W29 (N5245-20017)A31 port 4 ref coupler to front-panel REF 4 SOURCE OUT
  - \* As shown in **Figure 13**, install clamp (part number 1400-1334) to secure W29 (N5245-20017).

**Figure 13** Location of Cable Clamp for W29 (N5245-20017)

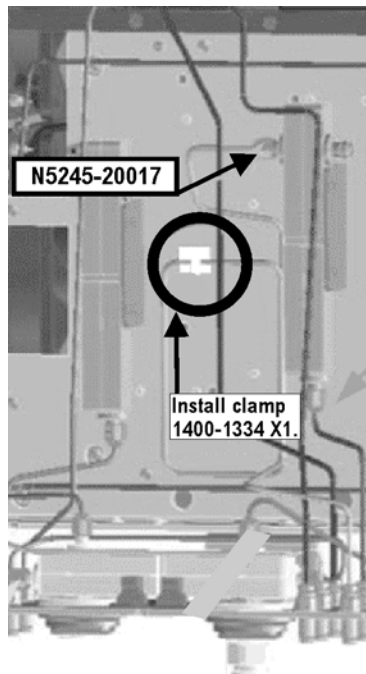

N5245\_015\_34

- W25 (N5245-20016)A30 port 3 ref coupler to front-panel REF 3 SOURCE OUT
  - \* As shown in **Figure 14**, install clamp (part number 1400-1334) to secure W25 (N5245-20016).

**Figure 14** Location of Cable Clamp for W25 (N5245-20016)

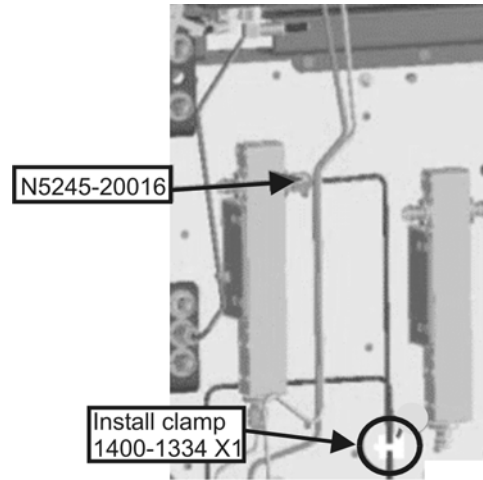

N5245\_013\_01

- W38 (N5245-20037)Port 3 RCVR C IN to A28 mixer brick (C)
- W26 (N5245-20015)A34 port 3 coupler to front-panel Port 3 CPLR ARM
- W24 (N5245-20098)Port 3 CPLR THRU to A34 port 3 coupler
- W23 (N5245-20051)A30 port 3 ref coupler to front-panel Port 3 SOURCE OUT
- W44 (N5245-20020)REF 3 RCVR R3 IN to A28 mixer brick (R3)
  - \* As shown in **Figure 14**, install two cable ties (part number 1400-0249) to secure W44 (N5245-20020) and W38 (N5245-20037) together.

**Figure 15** Location of Cable Ties for W38 (N5245-20037) and W44 (N5245-20020)

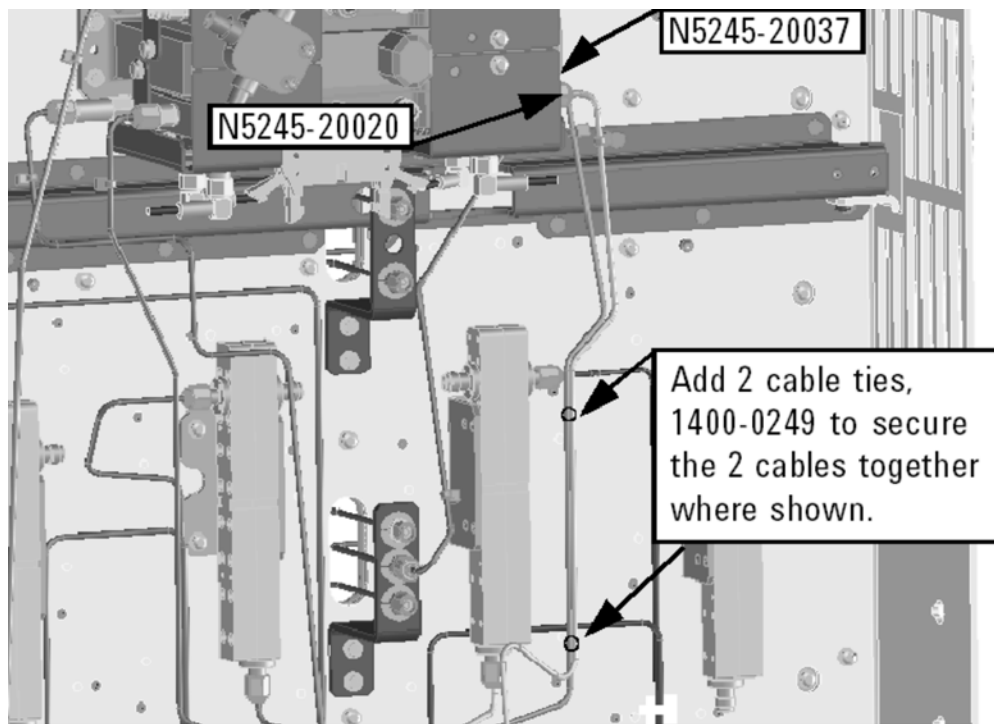

N5245\_015\_10

- W37 (reuse) (N5245-20041)Port 1 RCVR A IN to A27 mixer brick (A)
- W22 (N5245-20014)A33 port 1 coupler to front-panel Port 1 CPLR ARM
- W19 (reuse) (N5245-20039)A29 port 1 ref coupler to front-panel Port 1 SOURCE OUT
- W20 (N5245-20099)Port 1 CPLR THRU to A33 port 1 coupler
- W42 (reuse) (N5245-20007)REF 1 RCVR R1 IN to A37 reference mixer switch

- W21 (N5245-20110)A29 port 1 reference coupler to A37 reference mixer switch
  - \* As shown in **Figure 16**, install two clamps (part number 1400-1334) to secure W21 (N5245-20110).

**Figure 16** Location of Cable Clamps for W21 (N5245-20110)

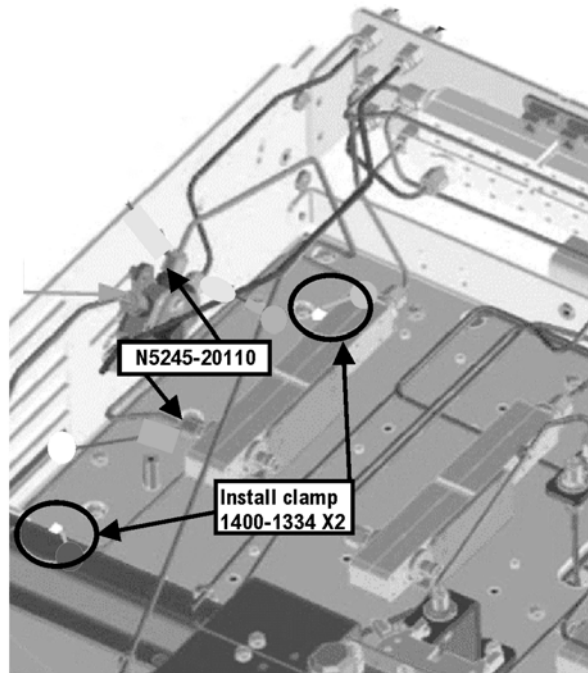

N5245\_013\_02

- W41 (reuse) (N5245-20006)A37 reference mixer switch to front-panel REF 1 SOURCE OUT
- W43 (reuse) (N5245-20009)A37 reference mixer switch to A27 mixer brick (R1)
- W18 (reuse) (N5245-20111)A32 port 2 reference coupler to W17
- W16 (N5245-20044)A31 port 4 reference coupler to W15
- W14 (N5245-20043)A30 port 3 reference coupler to W13
- W12 (reuse) (N5245-20109)A29 port 1 reference coupler to W11
- W54 (N5245-20022)A26 splitter to A28 mixer brick
- W53 (N5245-20023)A26 splitter to A27 mixer brick
- W52 (N5245-20013)A25 HMA26.5 to A26 splitter
- W58 (N5245-20095)A28 mixer brick to 50 ohm load (1810-0118)
  - \* After installing W58 to the mixer brick, attach the new 50 ohm load (1810-0118) using a 1/4 inch open end wrench to hold cable W58 in place.
  - \* Torque A26 splitter screws to 6 in-lbs.
- W70 (N5242-60013) A20 IF multiplexer (P203) to A12 SPAM (J2)
- W72 (N5242-60015) A20 IF multiplexer (P603) to A12 SPAM (J5)

## Step 20. Secure the Front Panel Bulkhead Connectors

Follow the instruction shown in [Figure 17](#) in this document.

**Figure 17 Bulkhead Connections, Front Panel**



- ① Secure 24x hex nuts on the front panel bulkhead connectors to 21 in-lbs using a "9mm" nut bit
- ② Go back and re-torque all 24 nuts to 21 in-lbs using a manual torque wrench

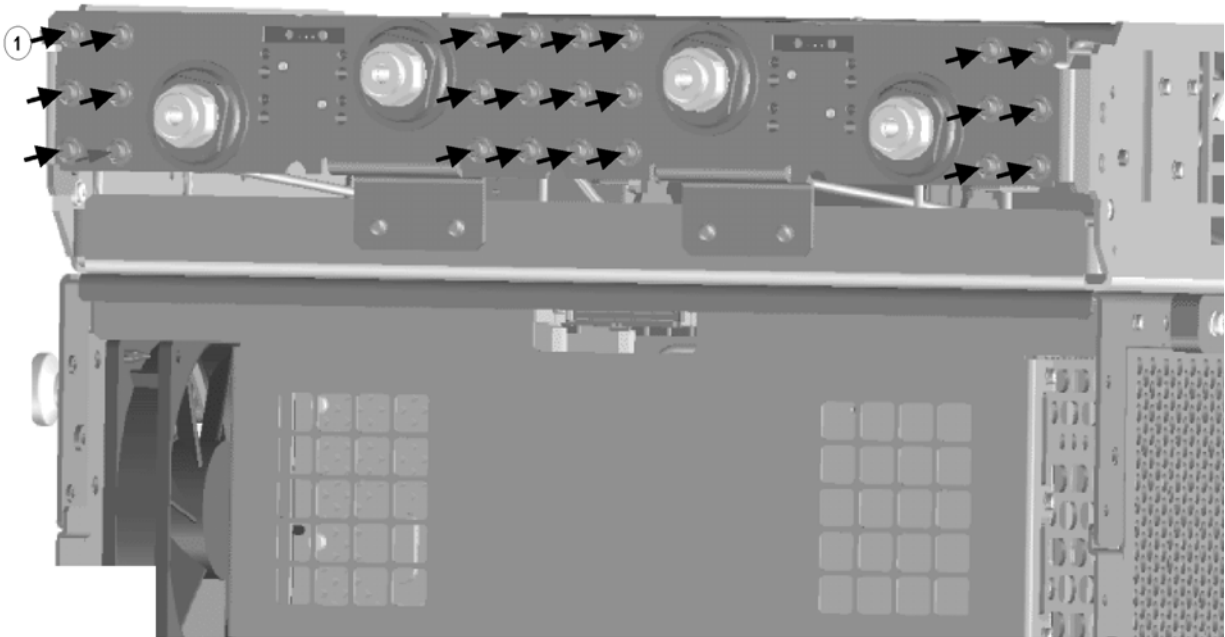

N5245\_015\_3

## Step 21. Reinstall the A23 Test Set Motherboard

---

**CAUTION** Follow instructions carefully when making cable connections, especially wire harness connections. Incorrect connections can destroy components, resulting in additional customer costs.

---

1. For instructions on reinstalling the board, click the Chapter 7 bookmark "Removing and Replacing the A23 test set motherboard" in the PDF Service Guide<sup>1</sup>.
2. Install ribbon cable, N5247-60015 from A23 test set motherboard J552 to A28 mixer brick (2) J52. To see an image showing the location of this cable, click the Chapter 6 bookmark "Bottom Ribbon Cables and Wire Harnesses, 4-Port, Option 400" in the PDF Service Guide<sup>1</sup>. New parts are listed in [Table 1 on page 7](#) of this document.

1. See ["Downloading the Online PNA Service Guide" on page 5](#).



3. Connect the other end of both LED board wire assemblies that were connected to the LED boards earlier. Refer to [Table 1 on page 7](#) for the connector locations on the test set motherboard.

## **Step 22. Disassemble the 2-Port Front Panel and Assemble the 4-Port Front Panel**

Before the front frame can be replaced, the items making up the back side of the front panel assembly must be removed. For instructions on removing these items, click the Chapter 7 bookmark “Removing and Replacing the A1-A3 and Other Front Panel Subassemblies” in the PDF Service Guide<sup>1</sup>. New parts are listed in [Table 1 on page 7](#).

1. In the section “Removing the A2 USB Board,” perform the only step.
2. In the section “Removing the A1 Front Panel Interface Board and Keypad Assembly,” perform steps 1 - 5.
3. In the section “Removing the Power Switch Board and Power Button Keypad,” perform only steps 1 and 2.
4. Remove the braided gasket from the backside edges of the 2-port front frame and install it in the 4-port front frame (N5247-20141).
5. Rebuild the front panel assembly with the new 4-port front frame by reversing the order of the instructions previously followed.

## **Step 23. Reinstall Front Panel Assembly**

For instructions on reinstalling the front panel assembly, click the Chapter 7 bookmark “Removing and Replacing the Front Panel Assembly” in the PDF Service Guide<sup>1</sup>.

In addition, attach the lower front dress panel to the test set front plate using 4x screws 0515-1227.

## **Step 24. Install the Overlays**

To see an image of the front panel overlay (N5242-80003), keypad overlay (N5242-80005), and power button overlay (N5242-80007), click the Chapter 6 bookmark “Front Panel Assembly, Front Side, All Options” in the PDF Service Guide<sup>1</sup>. New parts are listed in [Table 1 on page 7](#).

1. Remove the protective backing from the new front panel overlay (N5242-80003).
2. Loosely place the overlay in the recess on the lower front panel.
3. Placing two fingers at the middle, press the overlay firmly onto the frame while sliding your fingers in opposite directions towards the ends of the overlay. Repeat on all areas of the overlay.
4. Repeat steps 1-3 to install the keypad overlay (N5242-80005).
5. Repeat steps 1-3 to install the power button overlay (N5242-80007).
6. Install the new nameplate (N5245-80003).

## **Step 25. Install the Front Panel Jumper Cables**

Install twelve W36 front panel jumper cables (N5245-20155) - use 6 old jumpers and 6 new jumpers. To see an image of the front panel jumper cables, click the Chapter 7 bookmark “Removing and Replacing the Front Panel Assembly” in the PDF Service Guide<sup>1</sup>.

## Step 26. Position the Cables and Wires to Prevent Pinching

On the top side of the PNA, carefully position the grey flex cables so they can't be pinched between the covers and the rails.

On the bottom side of the PNA, carefully fold or push down the ribbon cables and wires so they can't be pinched between the hardware and the outer cover. Ribbon cables and wires must never be positioned on top of hardware.

## Step 27. Reinstall the Inner Cover

For instructions, click the Chapter 7 bookmark "Removing the Covers" in the PDF Service Guide<sup>1</sup>.

## Step 28. Reinstall the Outer Cover

For instructions, click the Chapter 7 bookmark "Removing the Covers" in the PDF Service Guide<sup>1</sup>.

## Step 29. Enable Option P04 (400)

### Procedure Requirements

- The analyzer must be powered up and operating to perform this procedure.
- The Network Analyzer program must be running.
- Obtain a license key for installation of this upgrade by following the instructions on the supplied Option Entitlement Certificate.

### Option Enable Procedure

1. To start the option enable utility, press UTILITY **System**, then **Service**, then **Option Enable**. An option enable dialog box will appear.
2. Click the arrow in the **Select Desired Option** box. A list of available options will appear.
3. In the **Select Desired Option** list, click **P04 - 4-Ports**.
4. Using the keyboard, enter the license key in the box provided. The license key is printed on the license message you received from Keysight. Enter this key *exactly* as it is printed on the message.
5. Click **Enable**.
6. Click **Yes** in answer to the displayed question in the **Restart Analyzer?** box.
7. When the installation is complete, click **Exit**.

### Option Verification Procedure

Once the analyzer has restarted and the Network Analyzer program is again running:

1. On the analyzer's **Help** menu, click **About Network Analyzer**.
2. Verify that "400" is listed after "Options:" in the display. Click **OK**.

---

**NOTE** If Option 400 has not been enabled, perform the [“Option Enable Procedure”](#) again. If the option is still not enabled, contact Keysight Technologies. Refer to [“Getting Assistance from Keysight” on page 3.](#)

---

## **Step 30. Perform Post-Upgrade Adjustments and Calibration**

### **Adjustments**

The following adjustments must be made due to the hardware changes of the analyzer.

- default EE
- source adjustment
- receiver adjustment
- receiver characterization

These adjustments are described in the PNA Service Guide and in the PNA on-line HELP. A list of equipment required to perform these adjustments is also found in the service guide.

After the specified adjustments have been performed, the analyzer should operate and phase lock over its entire frequency range.

### **Operator’s Check**

Perform the Operator’s Check to check the basic functionality of the analyzer. For instructions, click the Chapter 3 bookmark [“Tests and Adjustments”](#) in the PDF Service Guide<sup>1</sup>.

If you experience difficulty with the basic functioning of the analyzer, contact Keysight. Refer to [“Contacting Keysight” on page 3.](#)

### **Calibration**

Although the analyzer functions, its performance relative to its specifications has not been verified. It is recommended that a full instrument calibration be performed using the analyzer’s internal performance test software. To view information on the performance test software, click the Chapter 3 bookmark [“Tests and Adjustments”](#) in the PDF Service Guide<sup>1</sup>.

## **Step 31. Prepare the PNA for the User**

1. If necessary, reinstall front jumper cables.
2. Install the cable guards, pushing them over the front jumper cables until the cushioning material touches the front panel of the PNA.
3. Install the dust caps on the test ports.
4. Clean the analyzer, as needed, using a damp cloth.

---

1. See [“Downloading the Online PNA Service Guide” on page 5.](#)

This information is subject to change without notice.

© Keysight Technologies 2009 - 2014

December 1, 2014



N5245-90015  
[www.keysight.com](http://www.keysight.com)