

Keysight Extended Power Range and Bias Tees Upgrade Kit

To Upgrade PNA-X N5247A Option 200 to Option 219

Upgrade Kit Order Number: N5247AU-921

Keysight Kit Number: N5247-60101

NOTICE: This document contains references to Agilent Technologies. Agilent's former Test and Measurement business has become Keysight Technologies. For more information, go to www.keysight.com.



WARRANTY STATEMENT

THE MATERIAL CONTAINED IN THIS DOCUMENT IS PROVIDED "AS IS," AND IS SUBJECT TO BEING CHANGED, WITHOUT NOTICE, IN FUTURE EDITIONS. FURTHER, TO THE MAXIMUM EXTENT PERMITTED BY APPLICABLE LAW, KEYSIGHT DISCLAIMS ALL WARRANTIES, EITHER EXPRESS OR IMPLIED WITH REGARD TO THIS MANUAL AND ANY INFORMATION CONTAINED HEREIN, INCLUDING BUT NOT LIMITED TO THE IMPLIED WARRANTIES OF MERCHANTABILITY AND FITNESS FOR A PARTICULAR PURPOSE. KEYSIGHT SHALL NOT BE LIABLE FOR ERRORS OR FOR INCIDENTAL OR CONSEQUENTIAL DAMAGES IN CONNECTION WITH THE FURNISHING, USE, OR PERFORMANCE OF THIS DOCUMENT OR ANY INFORMATION CONTAINED HEREIN. SHOULD KEYSIGHT AND THE USER HAVE A SEPARATE WRITTEN AGREEMENT WITH WARRANTY TERMS COVERING THE MATERIAL IN THIS DOCUMENT THAT CONFLICT WITH THESE TERMS, THE WARRANTY TERMS IN THE SEPARATE AGREEMENT WILL CONTROL.

DFARS/Restricted Rights Notice

If software is for use in the performance of a U.S. Government prime contract or subcontract, Software is delivered and licensed as "Commercial computer software" as defined in DFAR 252.227-7014 (June 1995), or as a "commercial item" as defined in FAR 2.101(a) or as "Restricted computer software" as defined in FAR 52.227-19 (June 1987) or any equivalent agency regulation or contract clause. Use, duplication or disclosure of Software is subject to Keysight Technologies' standard commercial license terms, and non-DOD Departments and Agencies of the U.S. Government will receive no greater than Restricted Rights as defined in FAR 52.227-19(c)(1-2) (June 1987). U.S. Government users will receive no greater than Limited Rights as defined in FAR 52.227-14 (June 1987) or DFAR 252.227-7015 (b)(2) (November 1995), as applicable in any technical data.

Safety Notes

The following safety notes are used throughout this document. Familiarize yourself with each of these notes and its meaning before performing any of the procedures in this document.

| | |
|----------------|---|
| WARNING | Warning denotes a hazard. It calls attention to a procedure which, if not correctly performed or adhered to, could result in injury or loss of life. Do not proceed beyond a warning note until the indicated conditions are fully understood and met. |
|----------------|---|

| | |
|----------------|---|
| CAUTION | Caution denotes a hazard. It calls attention to a procedure that, if not correctly performed or adhered to, could result in damage to or destruction of the instrument. Do not proceed beyond a caution sign until the indicated conditions are fully understood and met. |
|----------------|---|

Description of the Upgrade

This upgrade converts your standard 2-port configurable test set analyzer (N5247A Option 200) to an extended power range analyzer with bias tees by adding:

- a 50-dB source attenuator and a bias tee in each source port channel
- a 50-dB receiver attenuator in each receiver channel

After installation of this upgrade, your analyzer will be an N5247A Option 219.

Getting Assistance from Keysight

Installing this upgrade kit requires special skills and experience. If you think you may not be qualified to do the work, or need advice, contact Keysight.

Contacting Keysight

Assistance with test and measurements needs and information on finding a local Keysight office are available on the Web at:

<http://www.keysight.com/find/assist>

If you do not have access to the Internet, please contact your Keysight field engineer.

| | |
|-------------|---|
| NOTE | In any correspondence or telephone conversation, refer to the Keysight product by its model number and full serial number. With this information, the Keysight representative can determine whether your product is still within its warranty period. |
|-------------|---|

Getting Prepared

CAUTION The PNA contains extremely sensitive components that can be ruined if mishandled. Follow instructions carefully when making cable connections, especially wire harness connections.

The person performing the work accepts responsibility for the full cost of the repair or replacement of damaged components.

To successfully install this upgrade kit, you will need the following:

- A license key - refer to “[License Key Redemption](#)” below.
- A PDF copy or a paper copy of the PNA Service Guide - refer to “[Downloading the Online PNA Service Guide](#)” below.
- An ESD-safe work area - refer to “[Protecting Your Workspace from Electrostatic Discharge](#)” below.
- Correct tools - refer to “[Tools Required for the Installation](#)” on page 6.
- Enough time - refer to “[About Installing the Upgrade](#)” on page 6.
- Test equipment for the post-upgrade adjustments and full instrument calibration. To view the equipment list, click the Chapter 3 bookmark “[Tests and Adjustments](#)” in the PDF Service Guide¹.

License Key Redemption

NOTE The enclosed Option Entitlement Certificate is a receipt, verifying that you have purchased a licensed option for the PNA of your choice. You must now use a Keysight Web page to request a license key for the instrument that will receive the option.

To enable the option product, you must request a license key from: <http://www.keysight.com/find/softwarelicense>. To complete the request, you will need to gather the following information:

- From the certificate
 - Order number
 - Certificate number
- From your instrument
 - Model number
 - Serial number
 - Host ID

The instrument information is available on the network analyzer – on the analyzer’s **Help** menu, click **About Network Analyzer**.

If you provide an email address, Keysight will promptly email your license key. Otherwise, you will receive your license key via postal mail.

1. See “[Downloading the Online PNA Service Guide](#)” on page 5.

Downloading the Online PNA Service Guide

To view the online Service Guide for your PNA model number, use the following steps:

1. Go to www.keysight.com.
2. In the Search box, enter the model number of the analyzer (Ex: N5247A) and click **Search**.
3. Click **Technical Support > Manuals**.
4. Click **Service Manual**.
5. Click the service guide title to download the PDF file.
6. When the PDF of the Service Guide is displayed, scroll through the Contents section bookmarks to locate the information needed.

Protecting Your Workspace from Electrostatic Discharge

For information, click on the Chapter 1 bookmark, “Electrostatic Discharge Protection” in the PDF Service Guide¹.

ESD Equipment Required for the Installation

| Description | Keysight Part Number |
|--|----------------------|
| ESD grounding wrist strap | 9300-1367 |
| 5-ft grounding cord for wrist strap | 9300-0980 |
| 2 x 4 ft conductive table mat and 15-ft grounding wire | 9300-0797 |
| ESD heel strap (for use with conductive floors) | 9300-1308 |

1. See “[Downloading the Online PNA Service Guide](#)” on page 5.

Tools Required for the Installation

| Description | Qty | Part Number |
|--|-----|-------------|
| T-10 TORX driver - set to 9 in-lbs (1.02 N.m) | 1 | N/A |
| T-20 TORX driver - set to 21 in-lbs (2.38 N.m) | 1 | N/A |
| 5/16-in (8 mm) nutsetter or open end torque wrench- set to 10 in-lbs (1.13 N.m) | 1 | N/A |
| 5/16-in (8 mm) nutsetter or open end torque wrench - set to 21 in-lbs (2.38 N.m) | 1 | N/A |
| 9 mm nutsetter or open end torque wrench - set to 21 in-lbs (2.38 N.m) | 1 | N/A |
| 1/4-in (6 mm) open end wrench | 1 | N/A |

CAUTION Use a 5/16-in torque wrench set to 10 in-lbs on all cable connections except the front and rear panel cable connectors. On these, use a 9 mm nutsetter or open end torque wrench set to 21 in-lb.

About Installing the Upgrade

| | |
|--|--|
| Products affected | N5247A Option 200 |
| Installation to be performed by | Keysight service center or personnel qualified by Keysight |
| Estimated installation time | 3 hours |
| Estimated adjustment time | 0.5 hours |
| Estimated full instrument calibration time | 4.5 hours |

Items Included in the Upgrade Kit¹

Check the contents of your kit against the following list. If any part is missing or damaged, contact Keysight Technologies. Refer to [“Contacting Keysight” on page 3](#).

Table 1 Contents of Upgrade Kit N5247-60101

| Ref Desig. | Description | Qty | Part Number |
|------------|--|-----|-------------|
| - | Installation note (this document) | 1 | N5247-90101 |
| A42 | Test port 1 bias tee | 2 | 5086-7732 |
| A45 | Test port 2 bias tee | | |
| A38 | Test port 1 source attenuator | 4 | 84905-60002 |
| A41 | Test port 2 source attenuator | | |
| A46 | Port 1 receiver attenuator | | |
| A49 | Port 2 receiver attenuator | | |
| - | Machine screw, M2.5 x 20, pan head (4 to attach side braces to bottom-side of PNA) | 6 | 0515-0374 |
| - | Machine screw, M4.0 x 10, pan head (2 to attach center brace on bottom-side of PNA) | 4 | 0515-0380 |
| - | Machine screw, M3.0 x 8, pan head (8 to attach attenuator assemblies to brackets; 8 to attach attenuator assembly brackets to test set deck; 4 to attach bias tee assemblies to test set deck; 2 to attach center brace on bottom-side of PNA) | 25 | 0515-0372 |
| - | Machine screw, M3.0 x 6, flat head (4 to attach bias tees to brackets) | 6 | 0515-1227 |
| - | Cable clamp, 2 to secure W146 (N5247-20058) | 5 | 1400-1334 |
| - | Cable tie wrap, 3 to secure W152 (N5247-20079) | 5 | 1400-0249 |
| - | Bracket for source and receiver attenuators | 2 | N5247-00005 |
| - | Brackets for bias tees | 2 | N5247-20129 |
| - | Brace (center), bottom side of PNA | 1 | N5247-20131 |
| - | Brace (side), bottom side of PNA | 2 | N5247-20132 |
| W27 | RF cable, A60 port 1 70 GHz doubler to A29 port 1 reference coupler | 1 | N5247-20044 |
| W30 | RF cable, A63 port 2 70 GHz doubler to A32 port 2 reference coupler | 1 | N5247-20043 |
| W101 | RF cable, A29 port 1 reference coupler to A38 port 1 source attenuator | 1 | N5247-20083 |
| W102 | RF cable, A38 port 1 source attenuator to front-panel port 1 SOURCE OUT | 1 | N5247-20014 |
| W103 | RF cable, front-panel port 1 CPLR THRU to A42 port 1 bias tee | 1 | N5247-20081 |
| W104 | RF cable, A33 port 1 coupler to A42 port 1 bias tee | 1 | N5247-20040 |
| W113 | RF cable, A32 port 2 reference coupler to A41 port 2 source attenuator | 1 | N5247-20083 |
| W114 | RF cable, A41 port 2 source attenuator to front-panel port 2 SOURCE OUT | 1 | N5247-20034 |
| W115 | RF cable, front-panel port 2 CPLR THRU to A45 port 2 bias tee | 1 | N5247-20027 |
| W116 | RF cable, A36 port 2 coupler to A45 port 2 bias tee | 1 | N5247-20042 |

1. In addition to the upgrade kit, the shipment includes an Option Entitlement Certificate. Refer to [“License Key Redemption” on page 4](#) for important information about this certificate.

Table 1 Contents of Upgrade Kit N5247-60101

| Ref Desig. | Description | Qty | Part Number |
|-------------------|---|------------|--------------------|
| W117 | RF cable, front-panel port 1 RCVR A IN to A46 port 1 receiver attenuator | 1 | N5247-20013 |
| W118 | RF cable, A46 port 1 receiver attenuator to A27 mixer brick (A) | 1 | N5247-20047 |
| W123 | RF cable, port 2 RCVR B IN to A49 port 2 receiver attenuator | 1 | N5247-20020 |
| W124 | RF cable, A49 port 2 receiver attenuator to A27 mixer brick (B) | 1 | N5247-20046 |
| W146 | RF cable, A32 port 2 ref coupler to front-panel REF 2 SOURCE OUT | 1 | N5247-20058 |
| W152 | RF cable, A29 port 1 reference coupler to A37 reference mixer switch | 1 | N5247-20079 |
| W153 | RF cable, A27 mixer brick (R2) to front-panel REF 2 RCVR R2 IN | 1 | N5247-20045 |
| - | Ribbon cable, A23 test set motherboard J549 to A38 port 1 source attenuator | 2 | N5245-60006 |
| - | Ribbon cable, A23 test set motherboard J546 to A41 port 2 source attenuator | | |
| - | Ribbon cable, A23 test set motherboard J205 to A46 port 1 receiver attenuator | 2 | N5247-60020 |
| - | Ribbon cable, A23 test set motherboard J208 to A49 port 2 receiver attenuator | | |
| - | Ribbon cable, A23 test set motherboard J541 to A42 port 1 bias tee | 2 | N5247-60021 |
| - | Ribbon cable, A23 test set motherboard J542 to A45 port 2 bias tee | | |

NOTE Extra quantities of items such as protective plastic caps, screws, cable ties, and cable clamps may be included in this upgrade kit. It is normal for some of these items to remain unused after the upgrade is completed.

Installation Procedure for the Upgrade

The network analyzer must be in proper working condition prior to installing this option. Any necessary repairs must be made before proceeding with this installation.

WARNING **This installation requires the removal of the analyzer's protective outer covers. The analyzer must be powered down and disconnected from the mains supply before performing this procedure.**

Overview of the Installation Procedure

- Step 1. Obtain a Keyword and Verify the Information.
- Step 2. Remove the Outer Cover.
- Step 3. Remove the Front Panel Assembly.
- Step 4. Remove Some Bottom-Side (Test Set) Cables.
- Step 5. Remove Port 1 and Port 2 Coupler Assemblies from the Test Set Deck.
- Step 6. Swap Brackets on the Port 1 and Port 2 Coupler Assemblies.
- Step 7. Assemble the Port 1 and Port 2 Step Attenuators.
- Step 8. Install the Step Attenuators.
- Step 9. Reinstall the Port 1 and Port 2 Coupler Assemblies.
- Step 10. Assemble the Bias Tees and Brackets.
- Step 11. Install the Bias Tees Assemblies.
- Step 12. Install Some Bottom-Side (Test Set) Cables.
- Step 13. Install Braces on Bottom-Side (Test Set) of PNA.
- Step 14. Reinstall Front Panel Assembly.
- Step 15. Position the Cables and Wires to Prevent Pinching.
- Step 16. Reinstall the Outer Cover.
- Step 17. Reinstall Front Panel Assembly.
- Step 18. Enable Option 219.
- Step 19. Perform Post-Upgrade Adjustments and Calibration.
- Step 20. Prepare the PNA for the User.

Step 1. Obtain a Keyword and Verify the Information

Follow the instructions on the Option Entitlement Certificate supplied to obtain a license key for installation of this upgrade. Refer to [“License Key Redemption” on page 4](#).

Verify that the model number, serial number, and option number information on the license key match those of the instrument on which this upgrade will be installed.

If the model number, serial number, or option number do not match those on your license key, you will not be able to install the option. If this is the case, contact Keysight for assistance before beginning the installation of this upgrade. Refer to [“Contacting Keysight” on page 3](#).

Once the license key has been received and the information verified, you can proceed with the installation at step 2.

Step 2. Remove the Outer Cover

For instructions, click the Chapter 7 bookmark “Removing the Covers” in the PDF Service Guide¹.

Step 3. Remove the Front Panel Assembly

For instructions, click the Chapter 7 bookmark “Removing and Replacing the Front Panel Assembly” in the PDF Service Guide¹.

1. See [“Downloading the Online PNA Service Guide” on page 5](#).

Step 4. Remove Some Bottom-Side (Test Set) Cables

CAUTION Be careful not to damage the center pins of the semirigid cables. Some flexing of the cables may be necessary but do not over-bend them.

NOTE When removing a cable, also remove the plastic cable clamp, if present. It is normal for some of the cable clamp's adhesive to remain.

1. Place the analyzer bottom-side up on a flat surface.
2. Remove the following semi-rigid cables, but keep them for reinstallation later.
To see an image showing the location of these cables, click the Chapter 6 bookmark "Bottom RF Cables, Standard 2-Port Configuration, Option 200" in the PDF Service Guide¹.
 - W12 (N5247-20059) A60 port 1 70 GHz doubler to W11
 - W24 (N5247-20061) A63 port 2 70 GHz doubler to W23
 - W34 (N5247-20039) A33 port 1 coupler to front panel port 1 CPLR ARM
 - W46 (N5247-20041) A36 port 2 coupler to front panel port 2 CPLR ARM
3. Remove and discard the following semi-rigid cables:
 - W27 (N5247-20074) A60 port 1 70 GHz doubler to A29 port 1 reference coupler
 - W30 (N5247-20052) A63 port 2 70 GHz doubler to A32 port 2 reference coupler
 - W31 (N5247-20037) A29 port 1 ref coupler to front-panel port 1 SOURCE OUT
 - W32 (N5247-20049) Port 1 CPLR THRU to A33 port 1 coupler
 - W43 (N5247-20036) A32 port 2 ref coupler to front-panel port 2 SOURCE OUT
 - W44 (N5247-20050) Port 2 CPLR THRU to A36 port 2 coupler
 - W47 (N5247-20053) Port 1 RCVR A IN to A27 mixer brick (A)
 - W50 (N5247-20054) Front-panel port 2 RCVR B IN to A27 mixer brick (B)
 - W56 (N5247-20055) REF 2 RCVR R2 IN to A27 mixer brick (R2)
 - W151 (N5247-20056) A29 port 1 reference coupler to A37 reference mixer switch
 - W154 (N5247-20057) A32 port 2 reference coupler to front panel REF 2 SOURCE OUT
4. Leave the gray flexible cables, the wire harnesses, and the ribbon cables connected where possible. Any that are removed should be labeled for reconnection later.

1. Refer to "Downloading the Online PNA Service Guide" on page 5.

Step 5. Remove Port 1 and Port 2 Coupler Assemblies from the Test Set Deck

For instructions on removing the coupler assemblies, click the Chapter 7 bookmark “Removing and Replacing the A29-A32 Reference Couplers and Reference Coupler Mounting Brackets” in the PDF Service Guide¹.

Step 6. Swap Brackets on the Port 1 and Port 2 Coupler Assemblies

Remove the brackets from the coupler assemblies being careful to remember which bracket was removed from each coupler. Reinstall the bracket that had been installed on the Port 1 Coupler Assembly onto the Port 2 Coupler Assembly. Next, reinstall the bracket that had been installed on the Port 2 Coupler Assembly onto the Port 1 Coupler Assembly.

Step 7. Assemble the Port 1 and Port 2 Step Attenuators

Refer to [Figure 1](#) for this step of the procedure. New parts are listed in [Table 1 on page 7](#). Use a T-10 TORX driver to tighten all screws.

Figure 1 Port 1 and Port 2 Step Attenuators Assembly

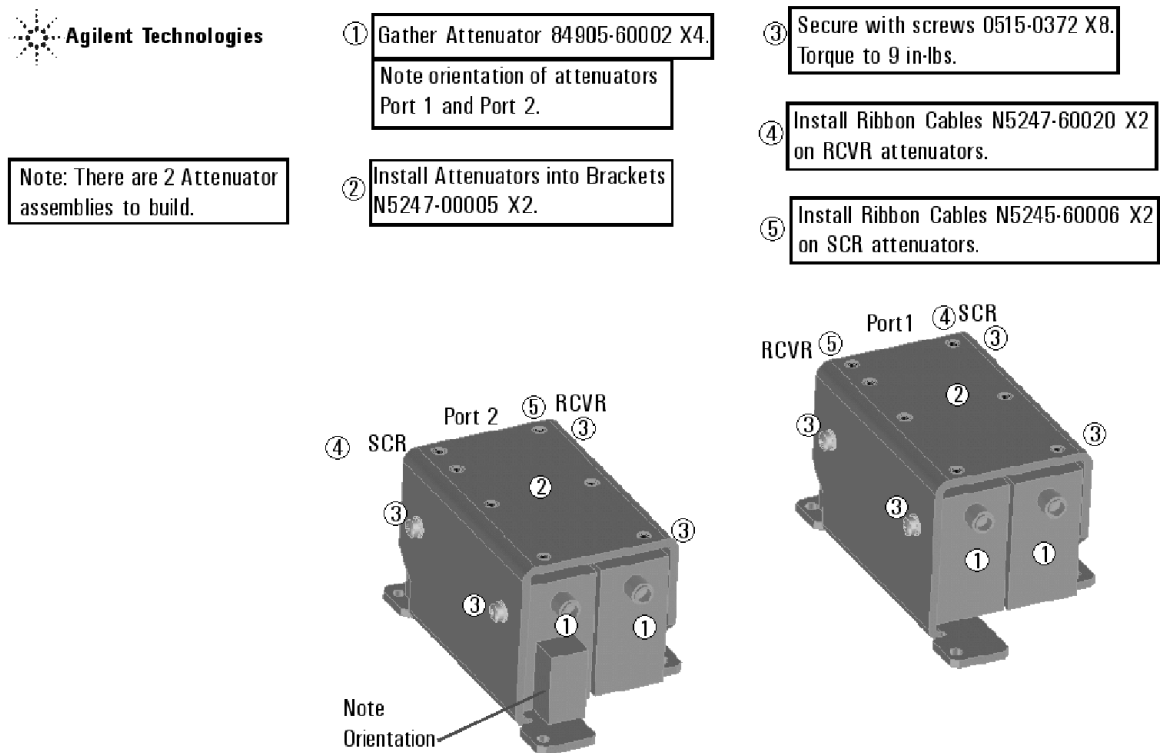

1. See “[Downloading the Online PNA Service Guide](#)” on page 5.

Step 8. Install the Step Attenuators

Refer to [Figure 2](#) for this step of the procedure. New parts are listed in [Table 1 on page 7](#). Use a T-10 TORX driver to tighten all screws.

Figure 2 Port 1 and Port 2 Step Attenuators Installation

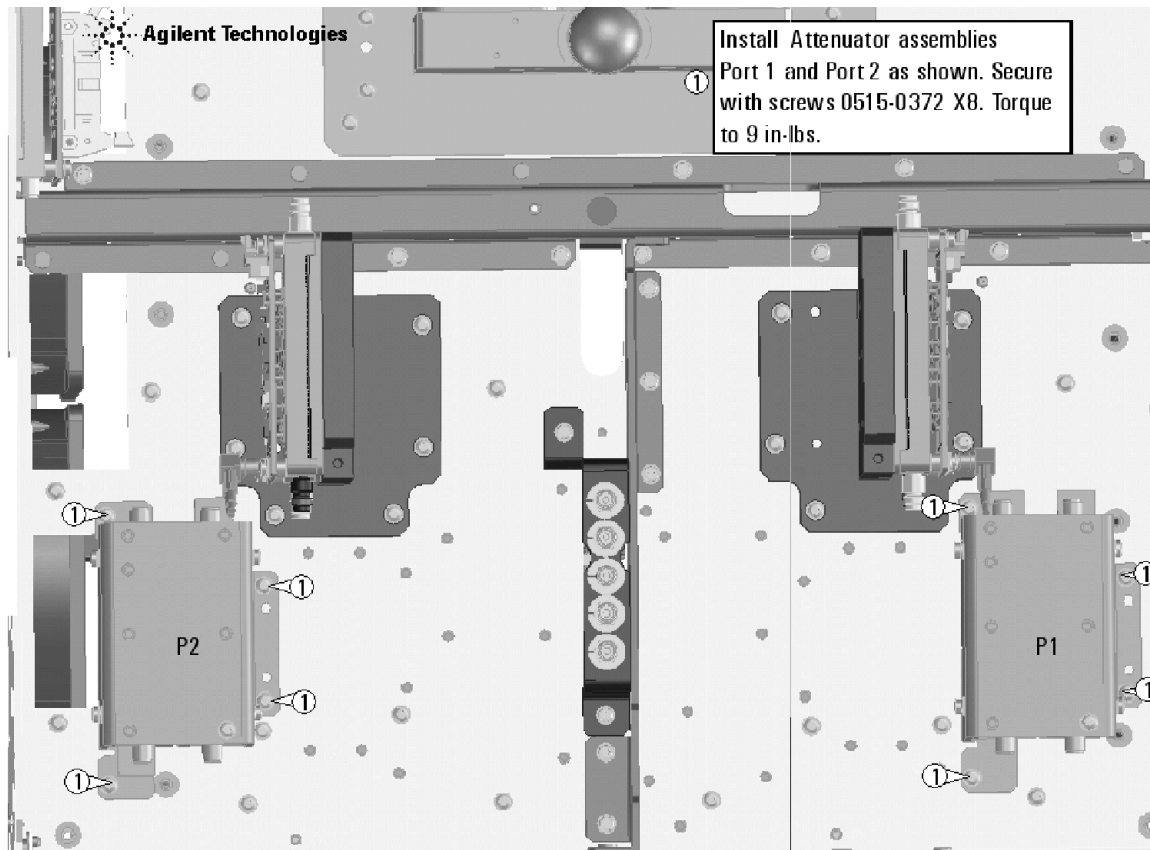

N5247_101_02

Step 9. Reinstall the Port 1 and Port 2 Coupler Assemblies

Refer to **Figure 3** for this step of the procedure. Use a T-10 TORX driver to tighten all screws.

Figure 3 Port 1 and Port 2 Coupler Assemblies Reinstallation

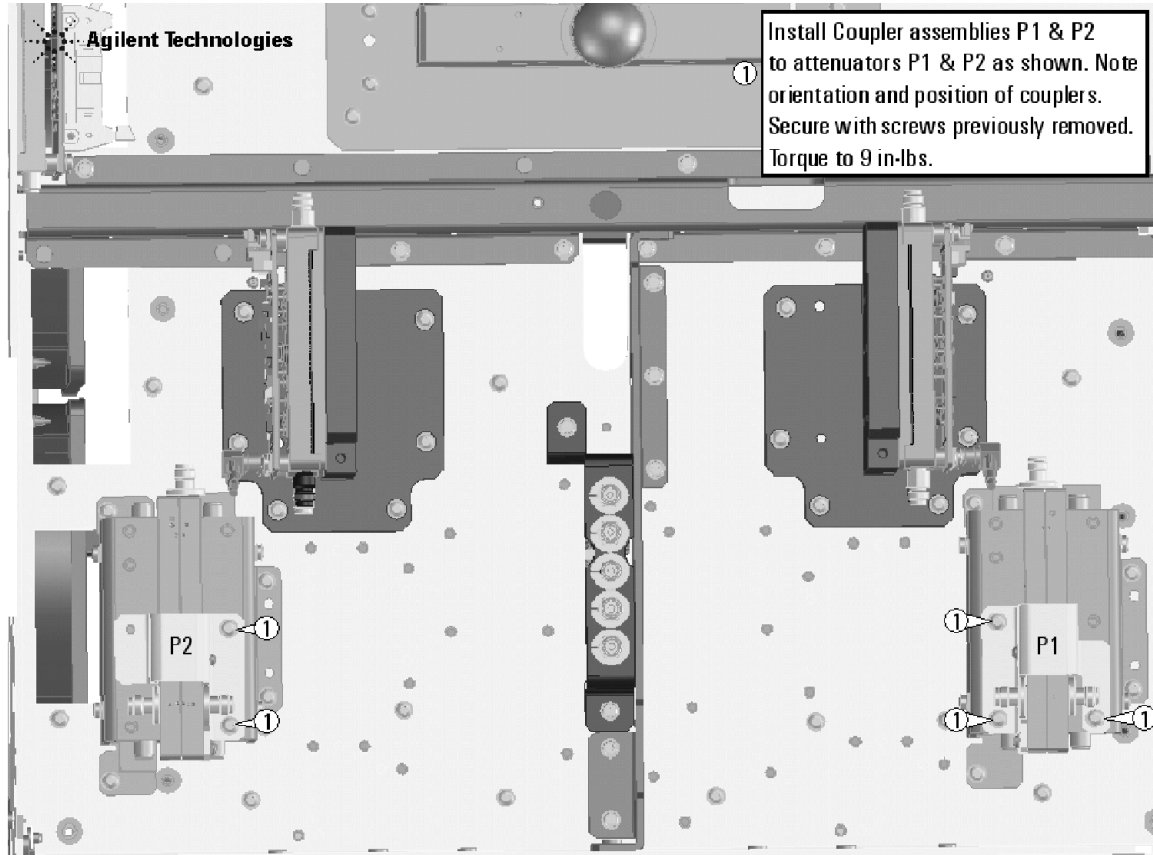

N5247_101_03

Step 10. Assemble the Bias Tees and Brackets

Refer to [Figure 4](#) for this step of the procedure. New parts are listed in [Table 1](#) on [page 7](#). Use a T-10 TORX driver to tighten all screws.

Figure 4 Bias Tees and Brackets

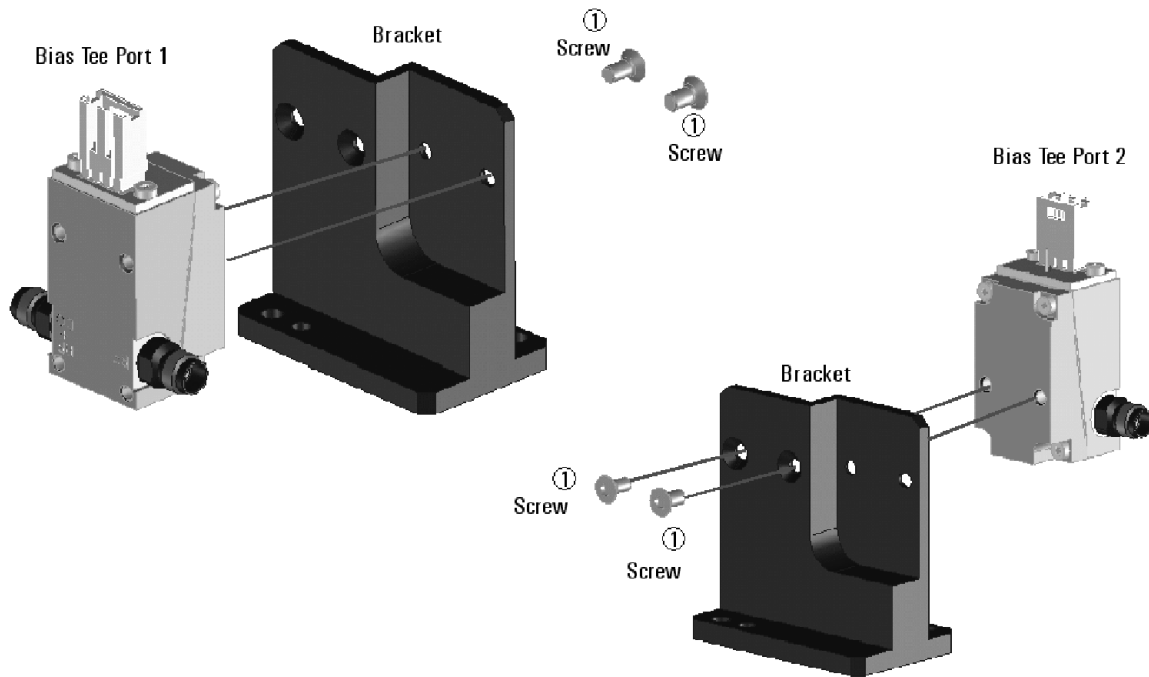

①

Gather 2x Bias Tee 5087-7732, and install 2x brackets N5247-20129. Secure with screws 0515-1227 X4. Torque to 9 in-lbs.

Note: Orientation of Bracket and Bias Tee. Slot on bracket should be on the back side.

N5247_101_04

Step 12. Install Some Bottom-Side (Test Set) Cables

CAUTION Use a 5/16-in torque wrench set to 10 in-lbs on all cable connections except the front and rear panel cable connectors. Torque these connections to 21 in-lb.

CAUTION Be careful not to damage the center pins of the semirigid cables. Some flexing of the cables may be necessary but do not over-bend them.

Semirigid Cables Required for Upgrading to an Option 219 PNA

To see images showing the location of these cables, click the Chapter 6 bookmark “Bottom RF Cables, 2-Port, Option 219” in the PDF Service Guide¹. New parts are listed in [Table 1 on page 7](#).

- W123 (N5247-20020) Port 2 RCVR B IN to A49 port 2 receiver attenuator
- W115 (N5247-20027) Front-panel port 2 CPLR THRU to A45 port 2 bias tee
- W46 (reuse) (N5247-20041) A36 port 2 coupler to front panel port 2 CPLR ARM
- W114 (N5247-20034) A41 port 2 source attenuator to front-panel port 2 SOURCE OUT
- W146 (N5247-20058) A32 port 2 ref coupler to front-panel REF 2 SOURCE OUT

* As shown in [Figure 6](#), install two clamps (part number 1400-1334) to secure cable W146.

1. See [“Downloading the Online PNA Service Guide” on page 5](#).

Figure 6 Location of Cable Clamps to Secure W146

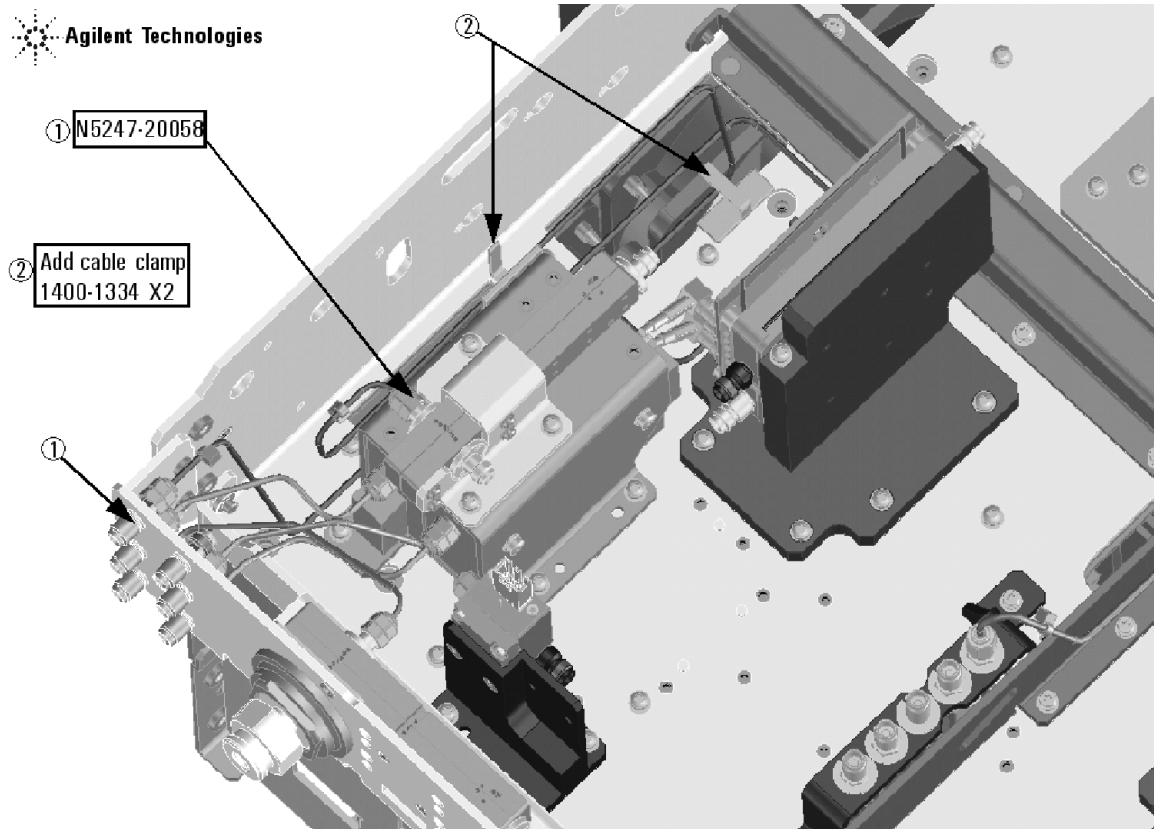

N5247_101_06

- W124 (N5247-20046) A49 port 2 receiver attenuator to A27 mixer brick (B)
- W153 (N5247-20045) A27 mixer brick (R2) to front-panel REF 2 RCVR R2 IN
- W116 (N5247-20042) A36 port 2 coupler to A45 port 2 bias tee
- W104 (N5247-20040) A33 port 1 coupler to A42 port 1 bias tee
- W117 (N5247-20013) Front-panel port 1 RCVR A IN to A46 port 1 receiver attenuator
- W103 (N5247-20081) Front-panel port 1 CPLR THRU to A42 port 1 bias tee
- W34 (reuse) (N5247-20039) A33 port 1 coupler to front panel port 1 CPLR ARM
- W102 (N5247-20014) A38 port 1 source attenuator to front-panel port 1 SOURCE OUT

- W152 (N5247-20079) A29 port 1 reference coupler to A37 reference mixer switch
- * As shown in **Figure 7**, install three cable ties (part number 1400-0249) to secure W152.

Figure 7 Location of Cable Ties to Secure W152

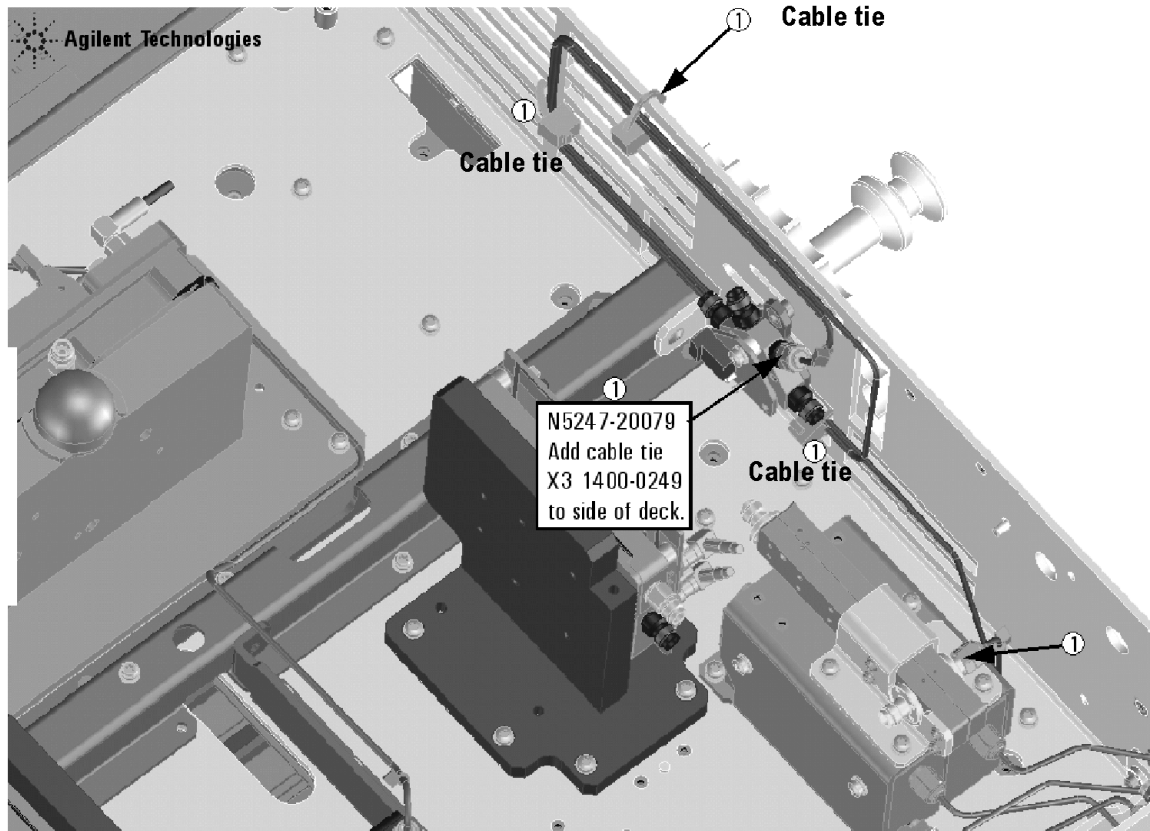

N5247_101_07

- W101 (N5247-20083) A29 port 1 reference coupler to A38 port 1 source attenuator
- W113 (N5247-20083) A32 port 2 reference coupler to A41 port 2 source attenuator
- W118 (N5247-20047) A46 port 1 receiver attenuator to A27 mixer brick (A)
- W27 (N5247-20044) A60 port 1 70 GHz doubler to A29 port 1 reference coupler
- W12 (reuse) (N5247-20059) A60 port 1 70 GHz doubler to W11
- W24 (reuse) (N5247-20061) A63 port 2 70 GHz doubler to W23
- W30 (N5247-20043) A63 port 2 70 GHz doubler to A32 port 2 reference coupler

Step 13. Install Braces on Bottom-Side (Test Set) of PNA

Refer to [Figure 8](#) for this step of the procedure. New parts are listed in [Table 1 on page 7](#). Use a T-10 TORX driver to tighten all screws.

Figure 8 Location of Braces on Bottom Side (Test Set) of PNA

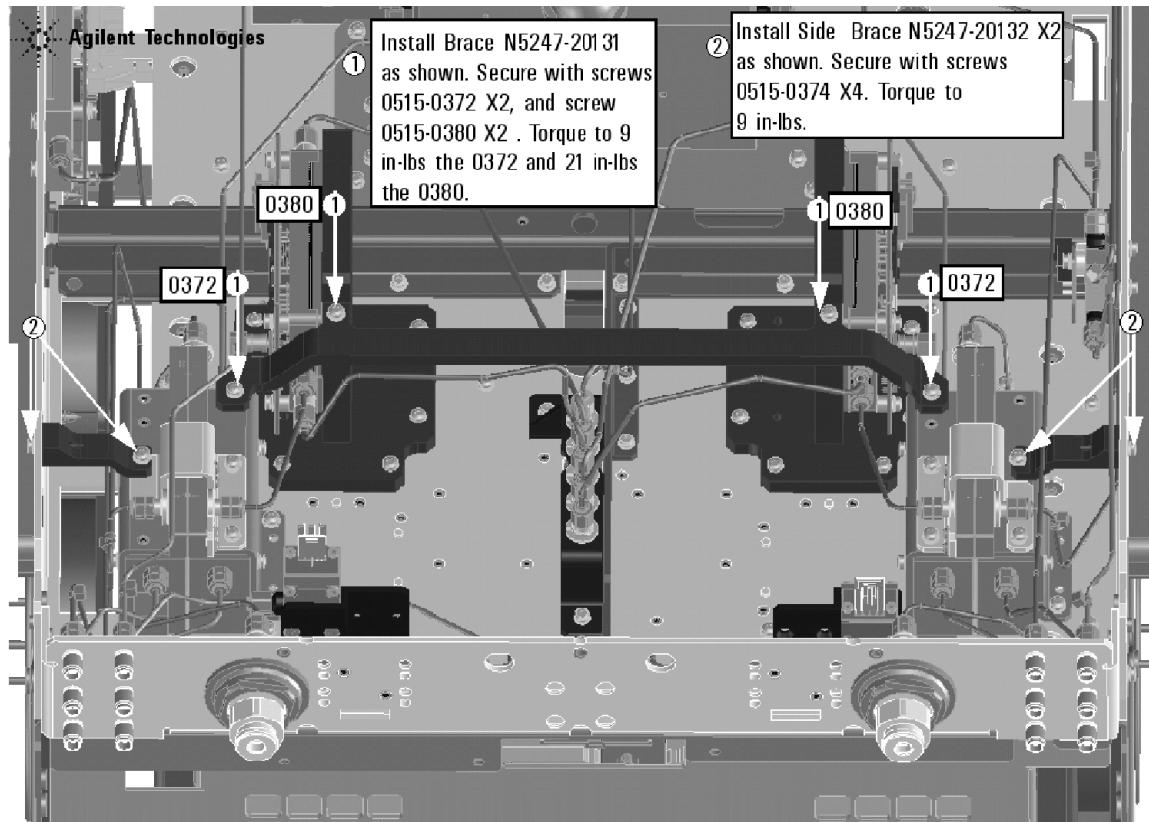

N5247_101_08

Step 14. Reinstall Front Panel Assembly

For instructions on reinstalling the front panel assembly, click the Chapter 7 bookmark “Removing and Replacing the Front Panel Assembly” in the PDF Service Guide¹.

Step 15. Position the Cables and Wires to Prevent Pinching

On the top side of the PNA, carefully position the grey flex cables so they can't be pinched between the covers and the rails.

On the bottom side of the PNA, carefully fold or push down the ribbon cables and wires so they can't be pinched between the hardware and the outer cover. Ribbon cables and wires must never be positioned on top of hardware.

1. See [“Downloading the Online PNA Service Guide” on page 5](#).

Step 16. Reinstall the Outer Cover

For instructions, click the Chapter 7 bookmark “Removing the Covers” in the PDF Service Guide¹.

Step 17. Reinstall Front Panel Assembly

For instructions on reinstalling the front panel assembly, click the Chapter 7 bookmark “Removing and Replacing the Front Panel Assembly” in the PDF Service Guide¹.

Step 18. Enable Option 219

Procedure Requirements

- The analyzer must be powered up and operating to perform this procedure.
- The Network Analyzer program must be running.
- A keyboard must be connected to the network analyzer.

Option Enable Procedure

1. To start the option enable utility, press UTILITY **System**, then **Service**, then **Option Enable**. An option enable dialog box will appear.
2. Click the arrow in the **Select Desired Option** box. A list of available options will appear.
3. In the **Select Desired Option** list, click **219 - Src/Rcvr Atten & Bias Ts 2-Port**.
4. Using the keyboard, enter the license key in the box provided. The license key is printed on the the license message you received from Keysight. Enter this key *exactly* as it is printed on the message.
5. Click **Enable**.
6. Click **Yes** in answer to the displayed question in the **Restart Analyzer?** box.
7. When the installation is complete, click **Exit**.

Option Verification Procedure

Once the analyzer has restarted and the Network Analyzer program is again running:

1. On the analyzer’s **Help** menu, click **About Network Analyzer**.
2. Verify that “219” is listed after “Options:” in the display. Click **OK**.

NOTE If Option 219 has not been enabled, perform the “Option Enable Procedure” (above) again. If the option is still not enabled, contact Keysight Technologies. Refer to [“Getting Assistance from Keysight” on page 3](#).

Step 19. Perform Post-Upgrade Adjustments and Calibration

Adjustments

The following adjustments must be made due to the hardware changes of the analyzer.

- source adjustment
- receiver adjustment
- receiver characterization
- IF gain

These adjustments are described in the PNA Service Guide and in the PNA on-line HELP. A list of equipment required to perform these adjustments is also found in the service guide.

To view this Service Guide information, click the Chapter 3 bookmark “Tests and Adjustments” in the PDF Service Guide¹.

After the specified adjustments have been performed, the analyzer should operate and phase lock over its entire frequency range.

Operator’s Check

Perform the Operator’s Check to check the basic functionality of the analyzer. For instructions, click the Chapter 3 bookmark “Tests and Adjustments” in the PDF Service Guide¹.

If you experience difficulty with the basic functioning of the analyzer, contact Keysight. Refer to [“Contacting Keysight” on page 3](#).

Calibration

Although the analyzer functions, its performance relative to its specifications has not been verified. It is recommended that a full instrument calibration be performed using the analyzer’s internal performance test software. To view information on the performance test software, click the Chapter 3 bookmark “Tests and Adjustments” in the PDF Service Guide¹.

Step 20. Prepare the PNA for the User

1. If necessary, reinstall front jumper cables.
2. Install the cable guards, pushing them over the front jumper cables until the cushioning material touches the front panel of the PNA.
3. Install the dust caps on the test ports.
4. Clean the analyzer, as needed, using a damp cloth.

1. See [“Downloading the Online PNA Service Guide” on page 5](#).

This information is subject to change without notice.
© Keysight Technologies 2011, 2014
August 2014



N5247-90101
www.keysight.com