

Keysight Second Source, Combiner, and Mechanical Switches Upgrade Kit

To Upgrade PNA-X N5247A Option 219 to Option 224

Upgrade Kit Order Numbers: N5247AU-922

Keysight Kit Number: N5247-60102

NOTICE: This document contains references to Agilent Technologies. Agilent's former Test and Measurement business has become Keysight Technologies. For more information, go to www.keysight.com.



WARRANTY STATEMENT

THE MATERIAL CONTAINED IN THIS DOCUMENT IS PROVIDED "AS IS," AND IS SUBJECT TO BEING CHANGED, WITHOUT NOTICE, IN FUTURE EDITIONS. FURTHER, TO THE MAXIMUM EXTENT PERMITTED BY APPLICABLE LAW, KEYSIGHT DISCLAIMS ALL WARRANTIES, EITHER EXPRESS OR IMPLIED WITH REGARD TO THIS MANUAL AND ANY INFORMATION CONTAINED HEREIN, INCLUDING BUT NOT LIMITED TO THE IMPLIED WARRANTIES OF MERCHANTABILITY AND FITNESS FOR A PARTICULAR PURPOSE. KEYSIGHT SHALL NOT BE LIABLE FOR ERRORS OR FOR INCIDENTAL OR CONSEQUENTIAL DAMAGES IN CONNECTION WITH THE FURNISHING, USE, OR PERFORMANCE OF THIS DOCUMENT OR ANY INFORMATION CONTAINED HEREIN. SHOULD KEYSIGHT AND THE USER HAVE A SEPARATE WRITTEN AGREEMENT WITH WARRANTY TERMS COVERING THE MATERIAL IN THIS DOCUMENT THAT CONFLICT WITH THESE TERMS, THE WARRANTY TERMS IN THE SEPARATE AGREEMENT WILL CONTROL.

DFARS/Restricted Rights Notice

If software is for use in the performance of a U.S. Government prime contract or subcontract, Software is delivered and licensed as "Commercial computer software" as defined in DFAR 252.227-7014 (June 1995), or as a "commercial item" as defined in FAR 2.101(a) or as "Restricted computer software" as defined in FAR 52.227-19 (June 1987) or any equivalent agency regulation or contract clause. Use, duplication or disclosure of Software is subject to Keysight Technologies' standard commercial license terms, and non-DOD Departments and Agencies of the U.S. Government will receive no greater than Restricted Rights as defined in FAR 52.227-19(c)(1-2) (June 1987). U.S. Government users will receive no greater than Limited Rights as defined in FAR 52.227-14 (June 1987) or DFAR 252.227-7015 (b)(2) (November 1995), as applicable in any technical data.

Safety Notes

The following safety notes are used throughout this document. Familiarize yourself with each of these notes and its meaning before performing any of the procedures in this document.

WARNING **Warning denotes a hazard. It calls attention to a procedure which, if not correctly performed or adhered to, could result in injury or loss of life. Do not proceed beyond a warning note until the indicated conditions are fully understood and met.**

CAUTION Caution denotes a hazard. It calls attention to a procedure that, if not correctly performed or adhered to, could result in damage to or destruction of the instrument. Do not proceed beyond a caution note until the indicated conditions are fully understood and met.

Description of the Upgrade

This upgrade converts your standard 2-port configurable test set analyzer (N5247A Option 219) to an N5247A Option 224 by adding:

- a second source assembly
- a second 13.5 GHz synthesizer board
- two additional doublers
- source outputs routed to the front panel
- source outputs routed to the rear panel
- a mechanical switch to each source port channel
- a source combiner to the port 1 channel
- rear-panel test set inputs

Getting Assistance from Keysight

By internet or phone, get assistance with all your test and measurement needs.

Contacting Keysight

Assistance with test and measurements needs and information on finding a local Keysight office are available on the Web at:

<http://www.keysight.com/find/assist>

If you do not have access to the Internet, please contact your Keysight field engineer.

NOTE In any correspondence or telephone conversation, refer to the Keysight product by its model number and full serial number. With this information, the Keysight representative can determine whether your product is still within its warranty period.

Getting Prepared

CAUTION The PNA contains extremely sensitive components that can be ruined if mishandled. Follow instructions carefully when making cable connections, especially wire harness connections.

The person performing the work accepts responsibility for the full cost of the repair or replacement of damaged components.

To successfully install this upgrade kit, you will need the following:

- A license key - refer to “[License Key Redemption](#)” below.
- A PDF copy or a paper copy of the PNA Service Guide - refer to “[Downloading the Online PNA Service Guide](#)” below.
- An ESD-safe work area - refer to “[Protecting Your Workspace from Electrostatic Discharge](#)” below.
- Correct tools - refer to “[Tools Required for the Installation](#)” on page 6.
- Enough time - refer to “[About Installing the Upgrade](#)” on page 6.
- Test equipment for the post-upgrade adjustments and full instrument calibration. To view the equipment list, click the Chapter 3 bookmark “[Tests and Adjustments](#)” in the PDF Service Guide¹.

License Key Redemption

NOTE The enclosed Option Entitlement Certificate is a receipt, verifying that you have purchased a licensed option for the PNA of your choice. You must now use a Keysight Web page to request a license key for the instrument that will receive the option.

To enable the option product, you must request a license key from: <http://www.keysight.com/find/softwarelicense>. To complete the request, you will need to gather the following information:

- From the certificate
 - Order number
 - Certificate number
- From your instrument
 - Model number
 - Serial number
 - Host ID

The instrument information is available on the network analyzer – on the analyzer’s **Help** menu, click **About Network Analyzer**.

If you provide an email address, Keysight will promptly email your license key. Otherwise, you will receive your license key via postal mail.

1. See “[Downloading the Online PNA Service Guide](#)” on page 5.

Downloading the Online PNA Service Guide

To view the online Service Guide for your PNA model number, use the following steps:

1. Go to www.keysight.com.
2. In the Search box, enter the model number of the analyzer (Ex: N5242A) and click **Search**.
3. Click **Technical Support > Manuals**.
4. Click **Service Manual**.
5. Click the service guide title to download the PDF file.
6. When the PDF of the Service Guide is displayed, scroll through the Contents section bookmarks to locate the information needed.

Protecting Your Workspace from Electrostatic Discharge

For information, click on the Chapter 1 bookmark, “Electrostatic Discharge Protection” in the PDF Service Guide¹.

ESD Equipment Required for the Installation

Description	Keysight Part Number
ESD grounding wrist strap	9300-1367
5-ft grounding cord for wrist strap	9300-0980
2 x 4 ft conductive table mat and 15-ft grounding wire	9300-0797
ESD heel strap (for use with conductive floors)	9300-1308

1. See “[Downloading the Online PNA Service Guide](#)” on page 5.

Tools Required for the Installation

Description	Qty	Part Number
T-6 TORX driver - set to 4 in-lbs (0.45 N.m)	1	N/A
T-8 TORX driver - set to 6 in-lbs (0.68 N.m)	1	N/A
T-10 TORX driver - set to 9 in-lbs (1.02 N.m)	1	N/A
T-20 TORX driver - set to 21 in-lbs (2.38 N.m)	1	N/A
5/16-in (8 mm) nutsetter or open end torque wrench- set to 10 in-lbs (1.13 N.m)	1	N/A
5/16-in (8 mm) nutsetter or open end torque wrench - set to 21 in-lbs (2.38 N.m)	1	N/A
3/16-in (5 mm) nutsetter or open end torque wrench - set to 6 in-lbs (0.68 N.m)	1	N/A
9/16-in (15 mm) nutsetter or open end torque wrench - set to 21 in-lbs (2.38 N.m)	1	N/A
5/8-in (16 mm) nutsetter or open end torque wrench - set to 21 in-lbs (2.38 N.m)	1	N/A
9 mm nutsetter or open end torque wrench - set to 21 in-lbs (2.38 N.m)	1	N/A
1/4-in (6 mm) open end wrench	1	N/A

CAUTION Use a 5/16-in torque wrench set to 10 in-lbs on all cable connections except the front and rear panel cable connectors. On these, use a 9 mm nutsetter or open end torque wrench set to 21 in-lb.

About Installing the Upgrade

Products affected	N5247A Option 219
Installation to be performed by	Keysight service center or personnel qualified by Keysight
Estimated installation time	5.0 hours
Estimated adjustment time	0.5 hour
Estimated full instrument calibration time	4.5 hours

Items Included in the Upgrade Kit

Check the contents of your kit against the following list. If any part is missing or damaged, contact Keysight Technologies. Refer to [“Getting Assistance from Keysight” on page 3](#).

Table 1 Contents of Upgrade Kit N5247-60102

Ref Desig.	Description	Qty	Part Number
--	Installation note (this document)	1	N5247-90102
A10	26.5 GHz source (2) assembly	1	5087-7780
A12	40 GHz doubler assembly, port 3	2	5087-7346
A13	40 GHz doubler assembly, port 4		
A17	13.5 GHz (source 2) synthesizer board	1	N5240-60074 Was N5242-60150
A50	Port 1 mechanical switch	3	N1811-60010
A51	SRC2 OUT1 mechanical switch		
A53	Port 2 mechanical switch		
A54	Combiner	1	11667-60016
A61	70 GHz doubler 3 (SRC 2 OUT 1) assembly port	2	5087-7336
A62	70 GHz doubler 4 (SRC 2 OUT 2) assembly port		
-	Cable guard	1	N5247-00019
--	Bracket for mechanical switches	2	N5247-20130
--	Bracket for combiner	1	N5247-00007
--	Bracket for cables	1	N5247-00006
--	Bracket for source (2) assembly	1	N5247-20136
-	Machine screw, M3.0 x 20, flat head (to attach bracket to source (2) assembly)	3	0515-2078
-	Machine screw, M3.0 x 18, pan head (to attach bracket to source (2) assembly)	2	0515-0666
-	Machine screw, M3.0 x 10, pan head (to attach cable bracket to deck)	3	0515-0374
-	Machine screw, M3.0 x 16, pan head (6 to attach 70 GHz doublers to mounts; 6 to attach switches to brackets)	15	0515-0375
-	Machine screw, M3.0 x 6, flat head (2 to attach front panel)	3	0515-1946
-	Machine screw, M3.0 x 8, pan head, (8 to attach switch/bracket assemblies to deck; 3 to attach combiner bracket to deck)	14	0515-0372
--	Machine screw, M2 x 14, pan head (to attach combiner to bracket)	3	0515-0661
-	Machine screw, M4.0 x 10, pan head (2 to attach A10 source 2 assy to chassis; 2 to attach A12 doubler 3 to chassis; 2 to attach A13 doubler 4 to chassis; 2 to attach A14 source 2 synthesizer board to chassis)	10	0515-0380
--	Cable clamp (3 to secure W68 (N5247-20088) and W134 (N5247-20095) together, and 2 to secure W153 (N5247-20045))	10	1400-1334

Table 1 Contents of Upgrade Kit N5247-60102

Ref Desig.	Description	Qty	Part Number
--	Cable tie wrap (to secure cable-ends together on 70 GHz doublers)	5	1400-0249
--	Front panel 1.85 mm male bulkhead connectors	2	5064-7891
--	Washers for front panel 1.85 mm male bulkhead connectors	2	2190-0104
--	Nuts for front panel 1.85 mm female bulkhead connectors	2	2950-0132
--	Lower front panel overlay	1	N5247-80001
--	Rear panel 1.85 mm female bulkhead connectors	3	5065-4673
--	Front panel 1.85 mm female bulkhead connectors	4	
--	Nut for rear panel 1.85 mm female bulkhead connectors	3	1250-3516
--	Nut for front panel 1.85 mm male bulkhead connectors	4	
--	Washer for rear panel 1.85 mm female bulkhead connectors	3	1250-3310
--	Washers for front panel 1.85 mm female bulkhead connectors	4	
--	Termination, 2.4 mm 50 GHz load	1	0955-2394 Was N5247-20138
W2	RF cable, A10 source (2) P1 to A17 13.5 GHz source (2) synthesizer J1207	1	N5245-20100
W7	RF cable, A10 source (2) P5 to A12 port 3 40 GHz doubler P1	1	N5245-20034
W8	RF cable, A10 source (2) P3 to A13 port 4 40 GHz doubler P1	1	N5247-20125
W9	RF cable, A10 source (2) P4 to A12 port 3 40 GHz doubler P4	1	N5245-20032
W10	RF cable, A12 port 3 40 GHz doubler P3 to A13 port 4 40 GHz doubler P4	1	N5245-20033
W15	RF cable, A12 port 3 40 GHz doubler P6 to W16	1	N5247-20114
W16	RF cable, A61 port 3 70 GHz doubler to W15	1	N5247-20060
W17	RF cable, A12 port 3 doubler P2 to W18	1	N5247-20086
W18	RF cable, A61 port 3 70 GHz doubler to W17	1	N5247-20084
W19	RF cable, A13 port 4 40 GHz doubler P6 to W20	1	N5247-20114
W20	RF cable, A62 port 4 70 GHz doubler to W19	1	N5247-20015
W21	RF cable, A13 port 4 40 GHz doubler P2 to W22	1	N5247-20086
W22	RF cable, A62 port 4 70 GHz doubler to W21	1	N5247-20068
W29	RF cable, Front-panel SRC 2 OUT 2 to A62 port 4 70 GHz doubler	1	N5247-20106
W60	RF cable, Front-panel jumper	2	N5247-20107
W67	RF cable, A12 port 3 40 GHz doubler P5 to W68	1	N5247-20096
W68	RF cable, Rear-panel port RF2 OUT (J12) to W67	1	N5247-20088
W87	RF cable, A14 frequency ref (J7) to A17 13.5 GHz (source 2) synth (J5)	1	N5242-60030
W93	RF cable, A61 port SRC 2 OUT 1 70 GHz doubler J2 to A12 40 GHz doubler J401	1	N5247-60010
W94	RF cable, A61 port SRC 2 OUT 1 70 GHz doubler J4 to A12 40 GHz doubler J500	1	N5247-60011

Table 1 Contents of Upgrade Kit N5247-60102

Ref Desig.	Description	Qty	Part Number
W95	RF cable, A62 port SRC 2 OUT 2 70 GHz doubler J2 to A13 40 GHz doubler J401	1	N5247-60012
W96	RF cable, A62 port SRC 2 OUT 2 70 GHz doubler J4 to A13 40 GHz doubler J500	1	N5247-60013
W125	RF cable, A50 port 1 mechanical switch to A60 port 1 70 GHz doubler	1	N5247-20030
W126	RF cable, A50 port 1 mechanical switch to A29 port 1 reference coupler	1	N5247-20031
W127	RF cable, A50 port 1 mechanical switch to PORT 1 SW SRC OUT	1	N5247-20102
W128	RF cable, front-panel PORT 1 COMB THRU IN to A54 combiner	1	N5247-20104
W129	RF cable, front-panel PORT 1 COMB ARM IN to A54 combiner	1	N5247-20103
W130	RF cable, A50 port 1 mechanical switch to A54 combiner	1	N5247-20105
W131	RF cable, A51 SRC2 OUT1 mechanical switch to A61 port 3 70 GHz doubler	1	N5247-20032
W132	RF cable, front-panel SRC 2 OUT 1 to A51 SRC2 OUT1 mech switch	1	N5247-20038
W133	RF cable, A51 SRC2 OUT1 mechanical switch to front panel SW SRC OUT	1	N5247-20101
W134	RF cable, rear-panel PORT 3 SW TSET IN (J7) to A51 SRC2 OUT1 mechanical switch	1	N5247-20095
W138	RF cable, A53 port 2 mechanical switch to A63 70 GHz doubler	1	N5247-20032
W140	RF cable, A53 port 2 mechanical switch to A32 port 2 reference coupler	1	N5247-20033
W141	RF cable, A53 port 2 mechanical switch to PORT 2 SW SRC OUT (J2)	1	N5247-20099
W142	RF cable, A53 port 2 mechanical switch to PORT 2 TSET IN (J1)	1	N5247-20089
W143	RF cable, rear panel jumper	1	N5247-20107
-	Ribbon cable, A23 test set motherboard J5 to A61 SRC 2 OUT 1 70 GHz doubler J1	2	N5247-60018
-	Ribbon cable, A23 test set motherboard J3 to A62 SRC 2 OUT 2 70 GHz doubler J1		

NOTE Extra quantities of items such as protective plastic caps, screws, cable ties, and cable clamps may be included in this upgrade kit. It is normal for some of these items to remain unused after the upgrade is completed.

Installation Procedure for the Upgrade

The network analyzer must be in proper working condition prior to installing this option. Any necessary repairs must be made before proceeding with this installation.

WARNING **This installation requires the removal of the analyzer's protective outer covers. The analyzer must be powered down and disconnected from the mains supply before performing this procedure.**

Overview of the Installation Procedure

- Step 1. Obtain a Keyword and Verify the Information.
- Step 2. Remove the Outer Cover.
- Step 3. Remove the Inner Cover.
- Step 4. Remove the Front Panel Assembly.
- Step 5. Remove the Braces on the Bottom Side of the PNA.
- Step 6. Remove the A23 Test Set Motherboard.
- Step 7. Remove the A24 IF Multiplexer Board.
- Step 8. Remove Some Bottom-Side (Test Set) Cables.
- Step 9. Remove the 70 GHz Doubler Assembly (Port 1) From the Test Set Deck.
- Step 10. Assemble the A61 70 GHz Doubler #3 on Mount of the Doubler Assembly (Port 1).
- Step 11. Reinstall the 70 GHz Doubler Assembly (Port 1).
- Step 12. Remove the 70 GHz Doubler Assembly (Port 2) From the Test Set Deck.
- Step 13. Assemble the A62 70 GHz Doubler #4 on Mount of the Doubler Assembly (Port 2).
- Step 14. Reinstall the 70 GHz Doubler Assembly (Port 2).
- Step 15. Assemble the A50, A51, and A53 Mechanical Switch Assemblies.
- Step 16. Install the A50, A51, and A53 Mechanical Switch Assemblies.
- Step 17. Assemble and Install the A54 Combiner Assembly.
- Step 18. Install the New Bulkhead Connectors in the Test Set Front Plate.
- Step 19. Assemble and Install the A12 40 GHz Doubler Assembly.
- Step 20. Install More Cables on the A12 40 GHz Doubler.
- Step 21. Assemble and Install the A13 40 GHz Doubler Assembly.
- Step 22. Install More Cables on the A13 40 GHz Doubler.
- Step 23. Install a Bracket to the A10 Source Assembly.
- Step 24. Assemble the A10 26.5 GHz Source 2 Assembly.
- Step 25. Install the A10 26.5 GHz Source 2 Assembly and Cables.

Step 26. Install the A17 13.5 GHz (Source 2) Synthesizer Board and Cables.

Step 27. Install the Cable Bracket Mount.

Step 28. Install the Cables.

Step 29. Install Rear Panel Hardware.

Step 30. Reinstall the A24 IF Multiplexer Board.

Step 31. Reinstall the A23 Test Set Motherboard.

Step 32. Install Cables on the A23 Test Set Motherboard.

Step 33. Reinstall the Braces on the Bottom Side of the PNA.

Step 34. Replace the Lower Front Panel Overlay.

Step 35. Reinstall Front Panel Assembly.

Step 36. Install the New Front Panel Jumper Cables.

Step 37. Position the Cables and Wires to Prevent Pinching.

Step 38. Reinstall the Inner Cover.

Step 39. Reinstall the Outer Cover.

Step 40. Enable Option 224.

Step 41. Perform Post-Upgrade Adjustments and Calibration.

Step 42. Prepare the PNA for the User.

Step 1. Obtain a Keyword and Verify the Information

Follow the instructions on the Option Entitlement Certificate supplied to obtain a license key for installation of this upgrade. Refer to [“License Key Redemption” on page 4](#).

Verify that the model number, serial number, and option number information on the license key match those of the instrument on which this upgrade will be installed.

If the model number, serial number, or option number do not match those on your license key, you will not be able to install the option. If this is the case, contact Keysight for assistance before beginning the installation of this upgrade. Refer to [“Contacting Keysight” on page 3](#).

Once the license key has been received and the information verified, you can proceed with the installation at step 2.

Step 2. Remove the Outer Cover

For instructions, click the Chapter 7 bookmark “Removing the Covers” in the PDF Service Guide¹.

Step 3. Remove the Inner Cover

For instructions, click the Chapter 7 bookmark “Removing the Covers” in the PDF Service Guide¹.

1. See [“Downloading the Online PNA Service Guide” on page 5](#).

Step 4. Remove the Front Panel Assembly

For instructions, click the Chapter 7 bookmark “Removing and Replacing the Front Panel Assembly” in the PDF Service Guide¹.

Step 5. Remove the Braces on the Bottom Side of the PNA

Remove the center brace and the two side braces from the bottom side of the PNA. Keep all parts for reinstallation later.

Step 6. Remove the A23 Test Set Motherboard

For instructions, click the Chapter 7 bookmark “Removing and Replacing the A23 Test Set Motherboard” in the PDF Service Guide¹.

Step 7. Remove the A24 IF Multiplexer Board

For instructions, click the Chapter 7 bookmark “Removing and Replacing the A24 IF Multiplexer Board” in the PDF Service Guide¹.

Step 8. Remove Some Bottom-Side (Test Set) Cables

CAUTION Be careful not to damage the center pins of the semirigid cables. Some flexing of the cables may be necessary but do not over-bend them.

NOTE When removing a cable, also remove the plastic cable clamp, if present. It is normal for some of the cable clamp’s adhesive to remain.

1. Place the analyzer bottom-side up on a flat surface.
2. Remove the following cables in the order listed. To see an image showing the location of these cables, click the Chapter 6 bookmark “Bottom RF Cables, Standard 2-Port Configuration, Option 219” in the PDF Service Guide¹.

These two cables may be discarded - they will not be reinstalled.

- W30 (N5247-20043) A63 port 2 70 GHz doubler to A32 port 2 reference coupler
- W27 (N5247-20044) A60 port 1 70 GHz doubler to A29 port 1 reference coupler

These six cables must be saved - they will be reinstalled.

- W12 (N5247-20059) A60 port 1 70 GHz doubler to W11
- W24 (N5247-20061) A63 port 2 70 GHz doubler to W23
- W53 (N5247-20048) A37 reference mixer switch to A27 mixer brick (R1)
- W118 (N5247-20047) A46 port 1 receiver attenuator to A27 mixer brick (A)

1. See “[Downloading the Online PNA Service Guide](#)” on page 5.

- W124 (N5247-20046) A49 port 2 receiver attenuator to A27 mixer brick (B)
- W153 (N5247-20045) A27 mixer brick (R2) to front-panel REF 2 RCVR R2 IN

Step 9. Remove the 70 GHz Doubler Assembly (Port 1) From the Test Set Deck

Remove the 70 GHz doubler assembly containing the A60 doubler from the test set deck. For instructions, click the Chapter 7 bookmark, “Removing and Replacing the A60-A63 70 GHz Doublers” in the PDF Service Guide¹. Keep all parts for reinstallation later.

Step 10. Assemble the A61 70 GHz Doubler #3 on Mount of the Doubler Assembly (Port 1)

1. Follow the instruction in [Figure 1](#) to install the A61 70 GHz doubler #3 on the doubler mount of the doubler assembly (Port 1). New parts are listed in [Table 1](#) on [page 7](#) of this document.

Figure 1 A61 Doubler #3 Installation on the Mount

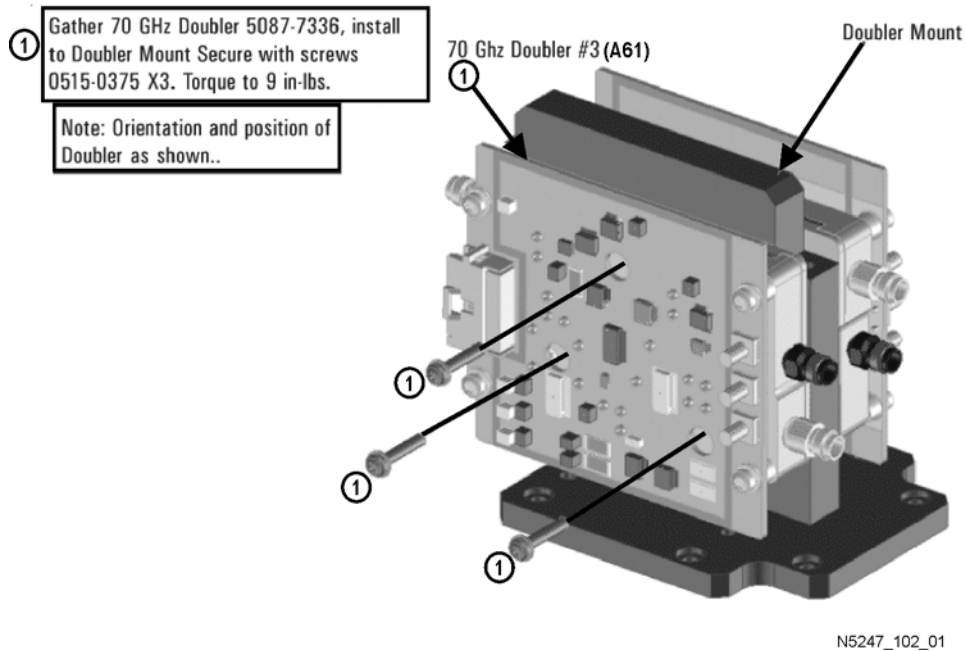

2. Connect the cables to the A61 70 GHz doubler #3 in the order shown in [Figure 2](#). The other ends of the cables will be connected later.

Figure 2 Cable Connections on the A61 Doubler #3

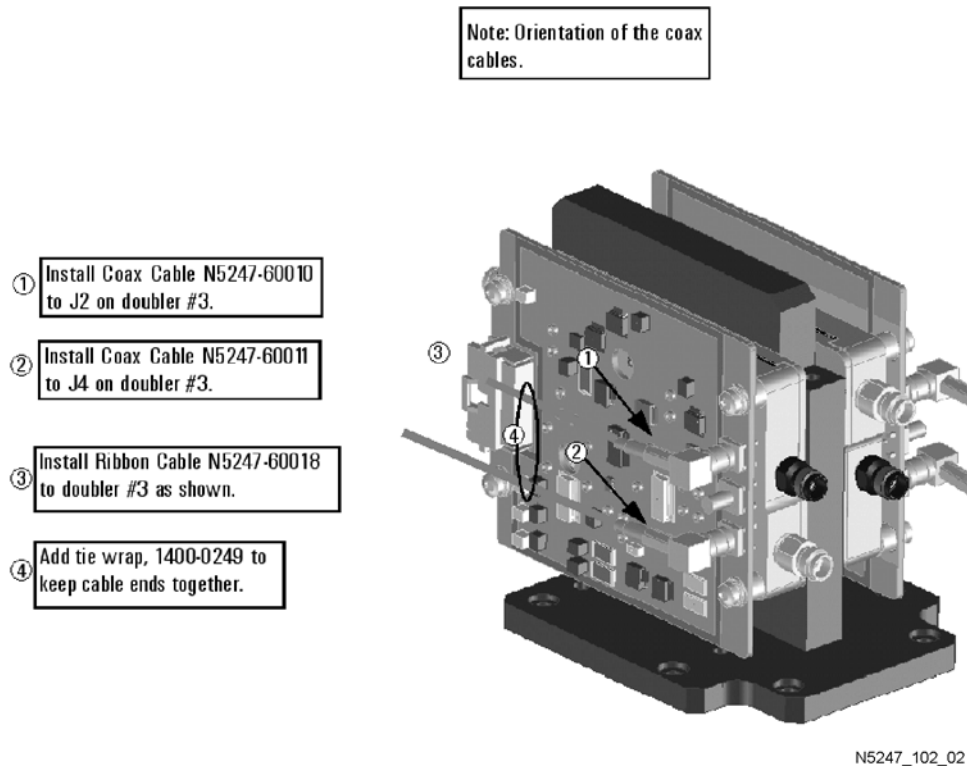

Step 11. Reinstall the 70 GHz Doubler Assembly (Port 1)

Reinstall the cables for the A60 70 GHz doubler, and then reinstall the 70 GHz doubler assembly (Port 1) on the test set deck, reusing the existing screws. For instructions, click the Chapter 7 bookmark, “Removing and Replacing the A60-A63 70 GHz Doublers” in the PDF Service Guide¹.

Step 12. Remove the 70 GHz Doubler Assembly (Port 2) From the Test Set Deck

Remove the 70 GHz doubler assembly containing the A63 doubler from the test set deck. For instructions, click the Chapter 7 bookmark, “Removing and Replacing the A60-A63 70 GHz Doublers” in the PDF Service Guide¹. Keep all parts for reinstallation later.

Step 13. Assemble the A62 70 GHz Doubler #4 on Mount of the Doubler Assembly (Port 2)

1. Follow the instruction in [Figure 3](#) to install the A62 70 GHz doubler #4 on the doubler mount of the doubler 2 assembly. New parts are listed in [Table 1 on page 7](#) of this document.

1. See “[Downloading the Online PNA Service Guide](#)” on page 5.

Figure 3 A62 Doubler #4 Installation on the Mount

- ① Gather 70 GHz Doubler 5087-7336, install to Doubler Mount Secure with screws 0515-0375 X3. Torque to 9 in-lbs.
- Note: Orientation and position of Doubler as shown..

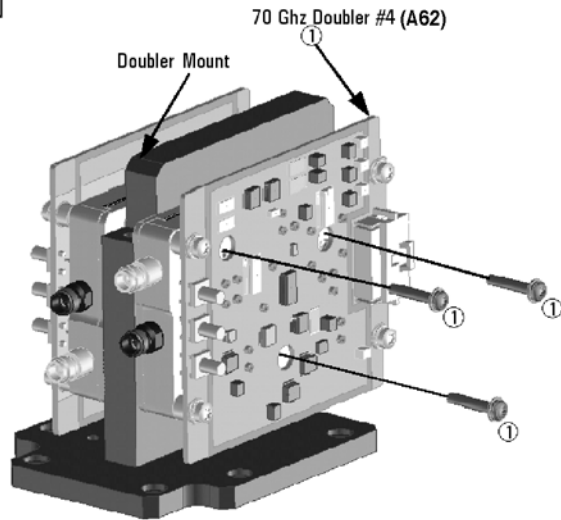

N5247_102_03

- 2. Connect the cables to the A62 70 GHz doubler #4 in the order shown in **Figure 4**. The other ends of the cables will be connected later.

Figure 4 Cable Connections on the A62 Doubler #4



Note: Orientation of the coax cables.

- ① Install Coax Cable N5247-60012 to J2 on doubler #4.
- ② Install Coax Cable N5247-60013 to J4 on doubler #4.
- ③ Install Ribbon Cable N5247-60018 to doubler #4 as shown.
- ④ Add tie wrap, 1400-0249 to keep cable ends together.

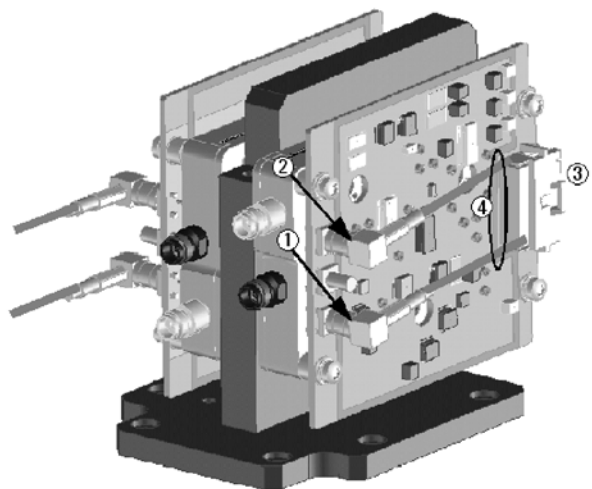

N5247_102_04

Step 14. Reinstall the 70 GHz Doubler Assembly (Port 2)

Reinstall the cables for the A63 70 GHz doubler, and then reinstall the A62/A63 70 GHz doubler assembly on the test set deck, reusing the existing screws. For instructions, click the Chapter 7 bookmark, "Removing and Replacing the A60-A63 70 GHz Doublers" in the PDF Service Guide¹.

Step 15. Assemble the A50, A51, and A53 Mechanical Switch Assemblies

Refer to [Figure 5](#) and [Figure 6](#) for this step of the procedure. New parts are listed in [Table 1 on page 7](#).

Figure 5 A53 Mechanical Switch Assembly

① Prefab Switch N1811-60010 to Bracket N5247-20130 as shown. Secure with Screws 0515-0375 X2, Torque to 9 in-lbs. Note: Slot on bracket toward back side of instrument

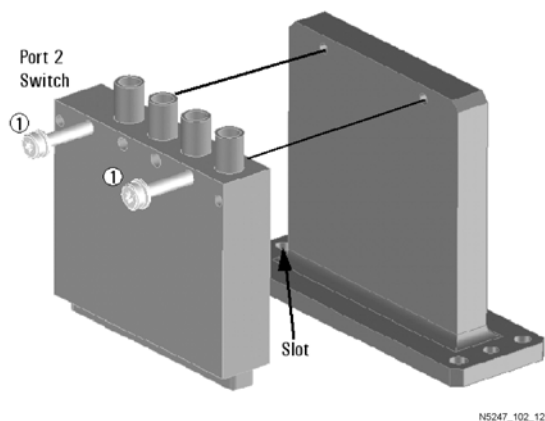

1. See "Downloading the Online PNA Service Guide" on page 5.

Figure 6 A50 and A51 Mechanical Switches Assembly

① Prefab Switches N1811-60010 X2 to Bracket N5247-20130 as shown. Secure with Screws 0515-0375 X4. Torque to 9 in-lbs. Note: Slot on bracket toward back side of instrument

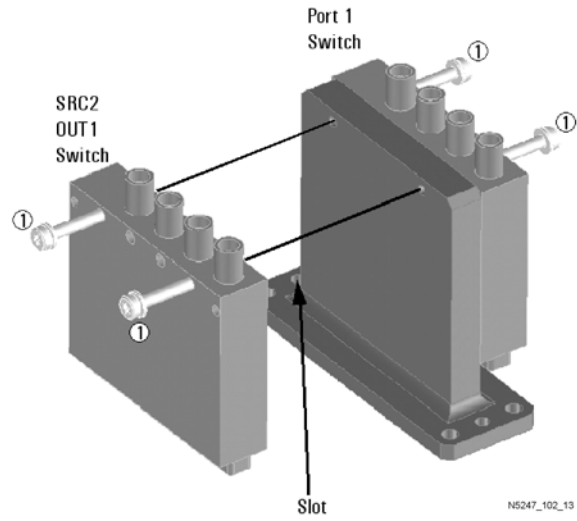

Step 16. Install the A50, A51, and A53 Mechanical Switch Assemblies

Refer to [Figure 7](#) for this step of the procedure. New parts are listed in [Table 1](#) on [page 7](#).

Figure 7 A50, A51, and A53 Mechanical Switches Assembly

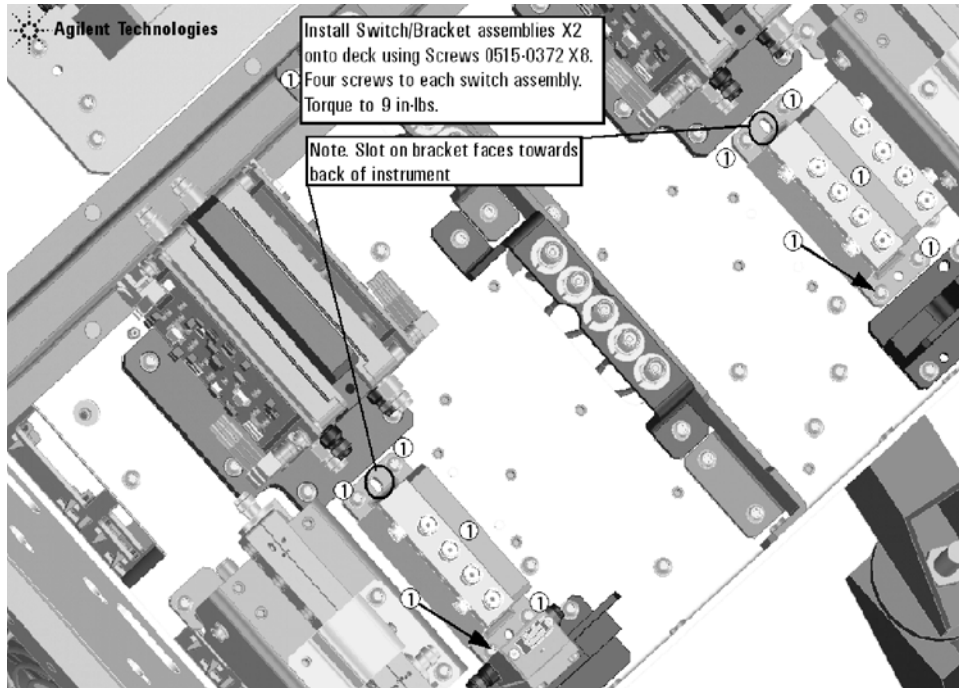

N5247_102_14

Step 17. Assemble and Install the A54 Combiner Assembly

Refer to [Figure 8](#) for this step of the procedure. New parts are listed in [Table 1 on page 7](#).

Figure 8 A54 Combiner Assembly and Installation

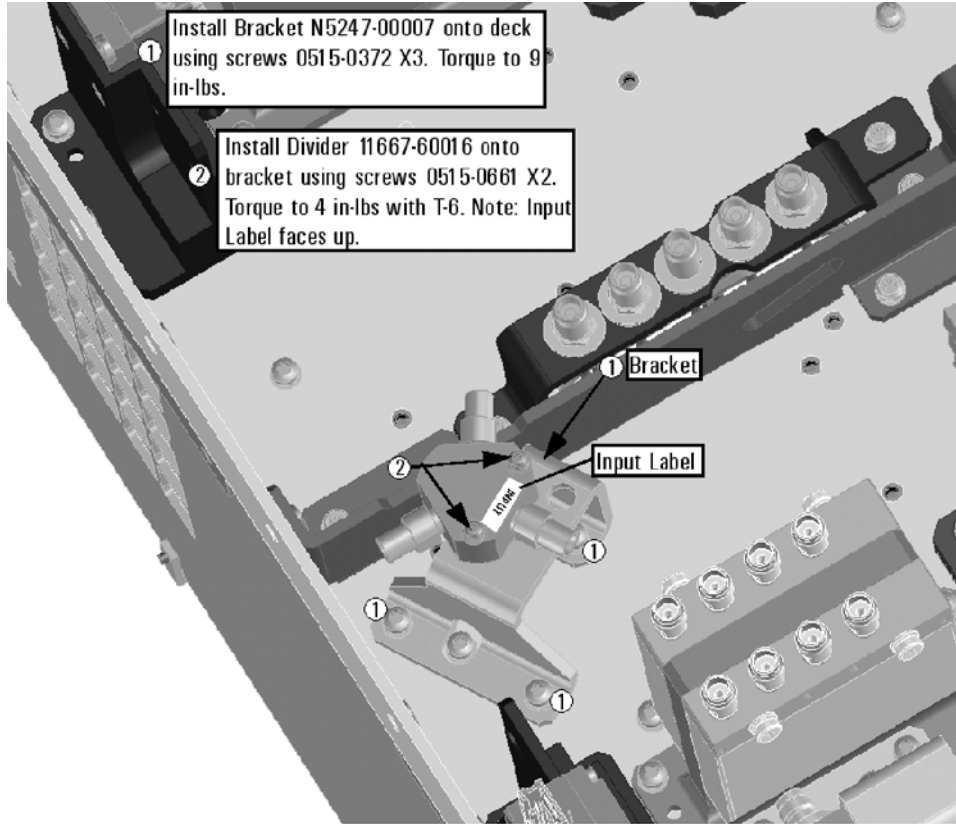

N5247_102_15

Step 18. Install the New Bulkhead Connectors in the Test Set Front Plate

Refer to [Figure 9](#) and [Figure 10](#) for this step of the procedure. New parts are listed in [Table 1](#) on [page 7](#).

Figure 9 Front Panel Bulkhead Connectors (Male) Installation

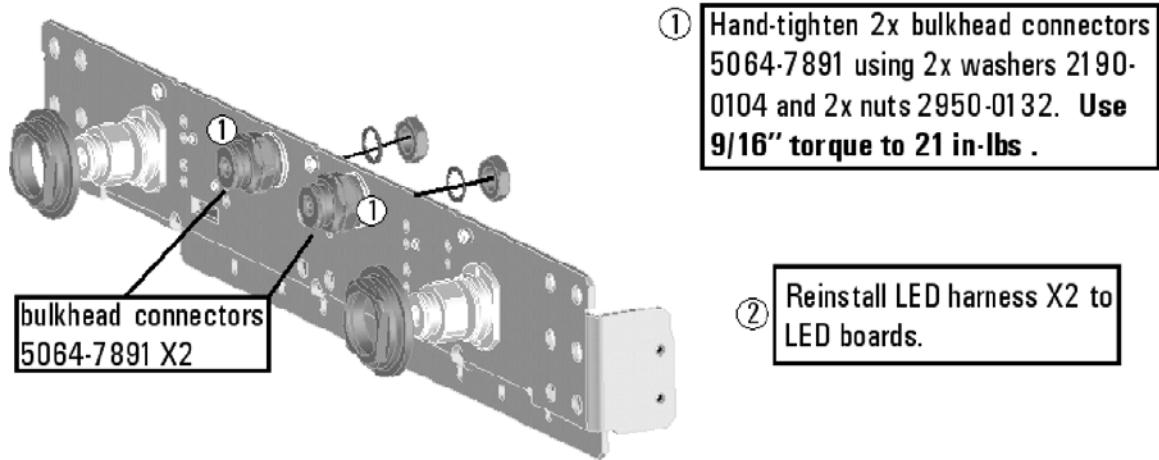

N5247_102_16

Figure 10 Front Panel Bulkhead Connectors (Female) Installation

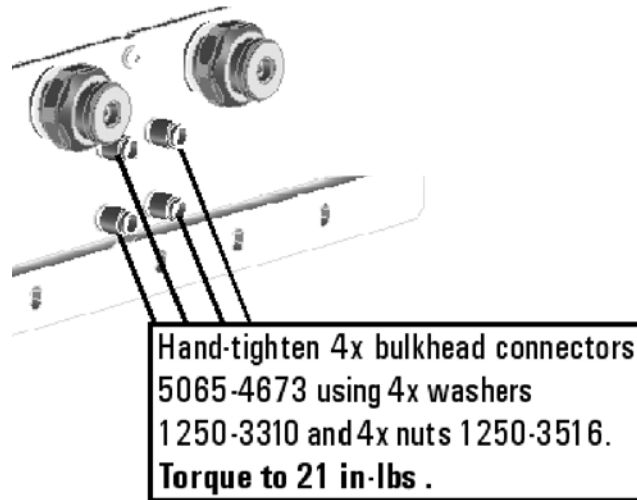

Step 19. Assemble and Install the A12 40 GHz Doubler Assembly

Follow the five instructions shown in [Figure 11](#).

Figure 11 A12 40 GHz Doubler 3, Assembly and Installation

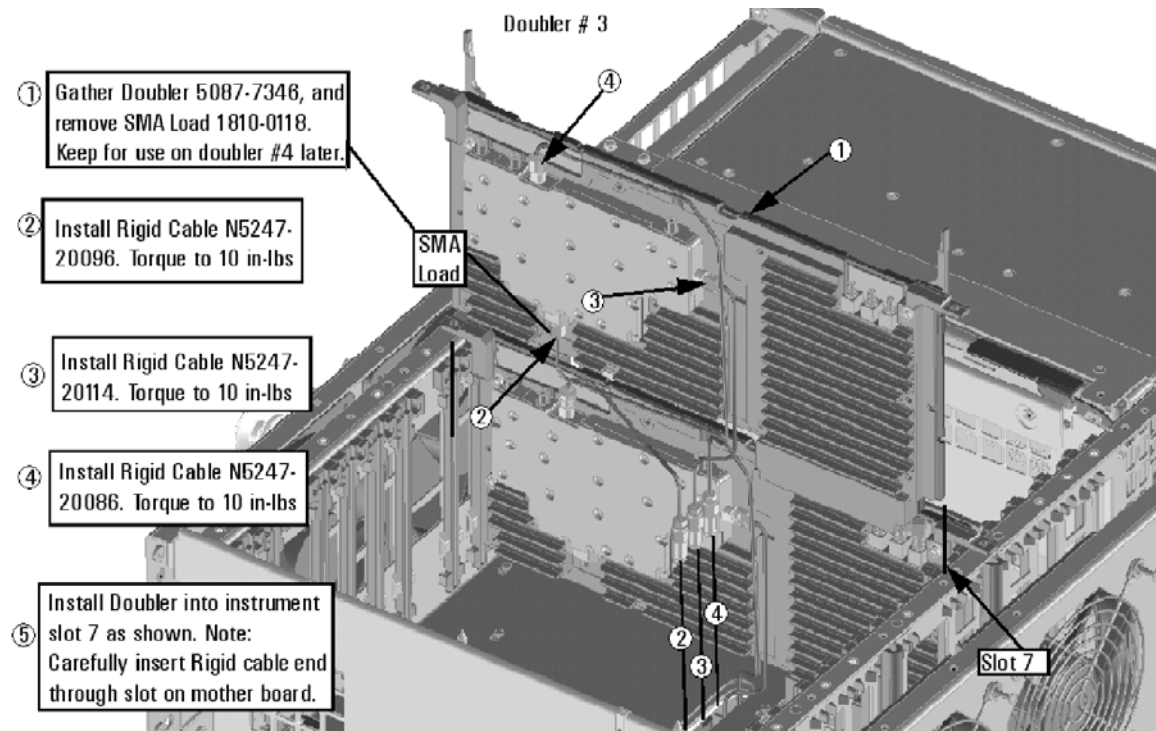

N5247_102_08

Step 20. Install More Cables on the A12 40 GHz Doubler

Follow the three instructions shown in [Figure 12](#).

Figure 12 A12 40 GHz Doubler 3, Cable Installation

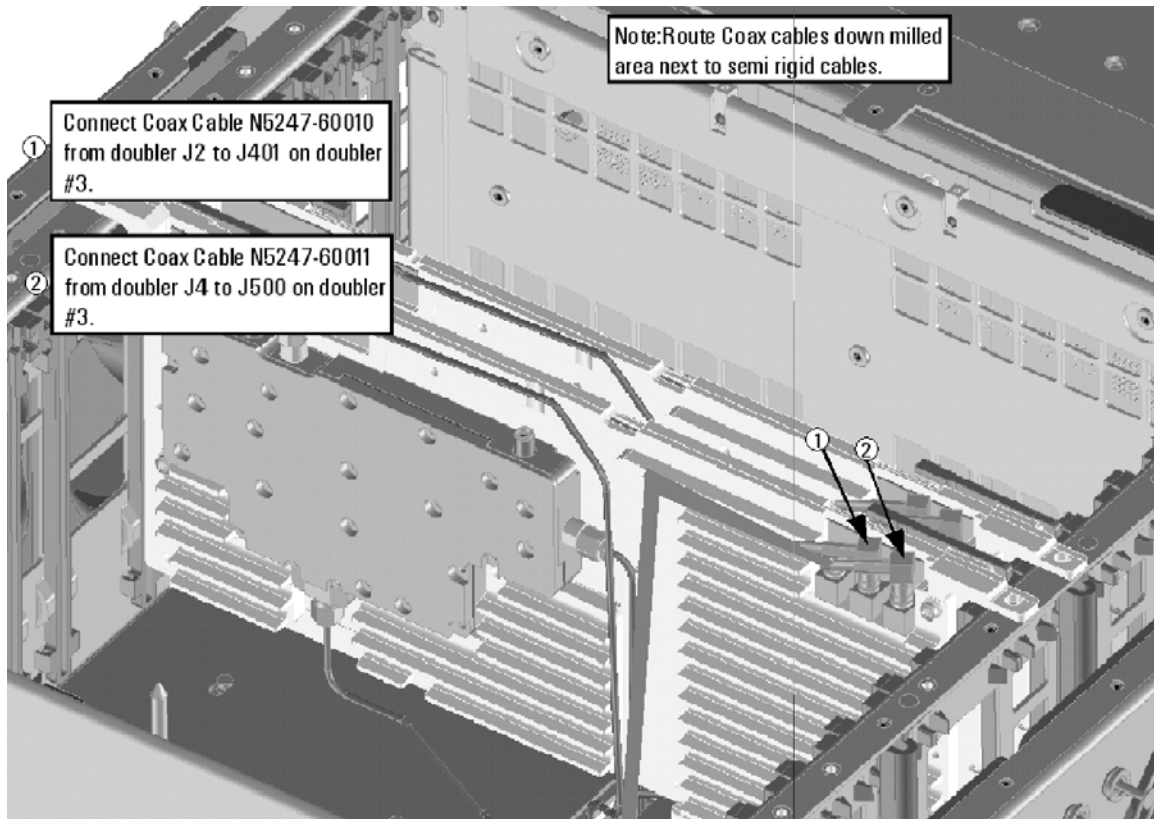

N5247_102_09

Step 21. Assemble and Install the A13 40 GHz Doubler Assembly

Follow the five instructions shown in [Figure 13](#).

Figure 13 A13 40 GHz Doubler 4, Assembly and Installation

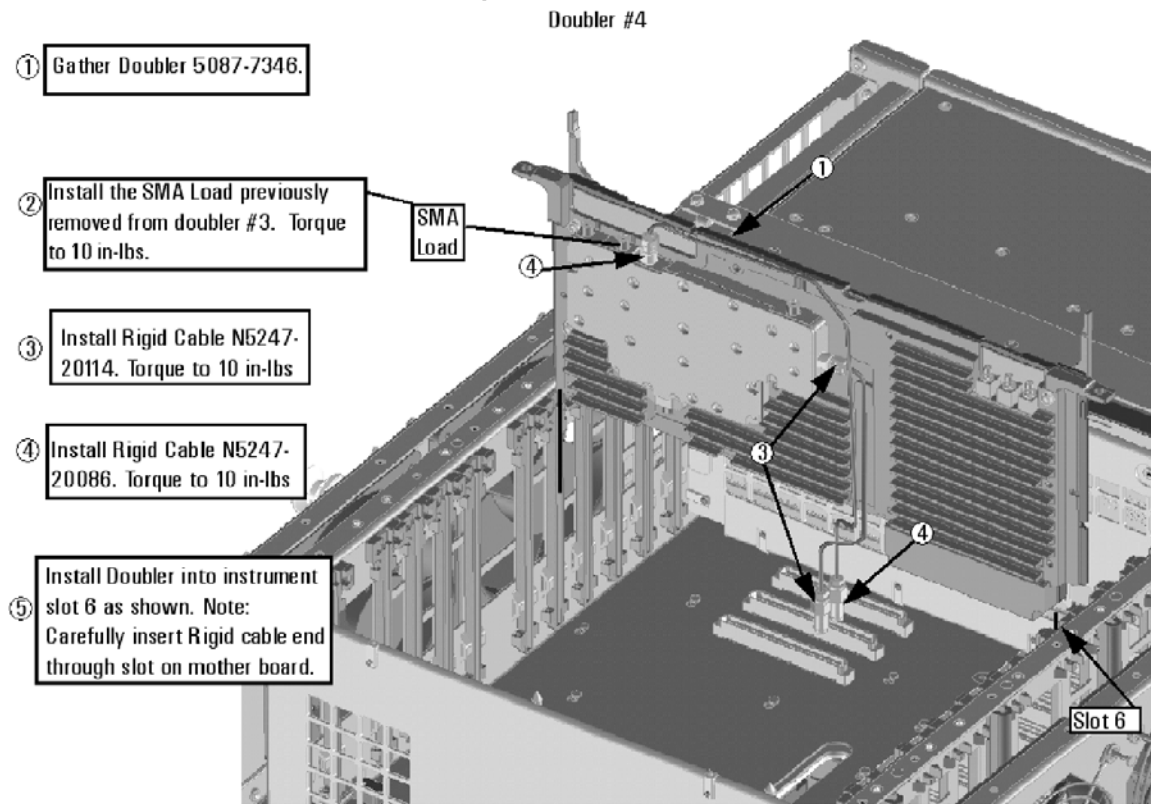

N5247 102 06

Step 22. Install More Cables on the A13 40 GHz Doubler

Follow the three instructions shown in [Figure 14](#).

Figure 14 A13 40 GHz Doubler 4 Cable Installation

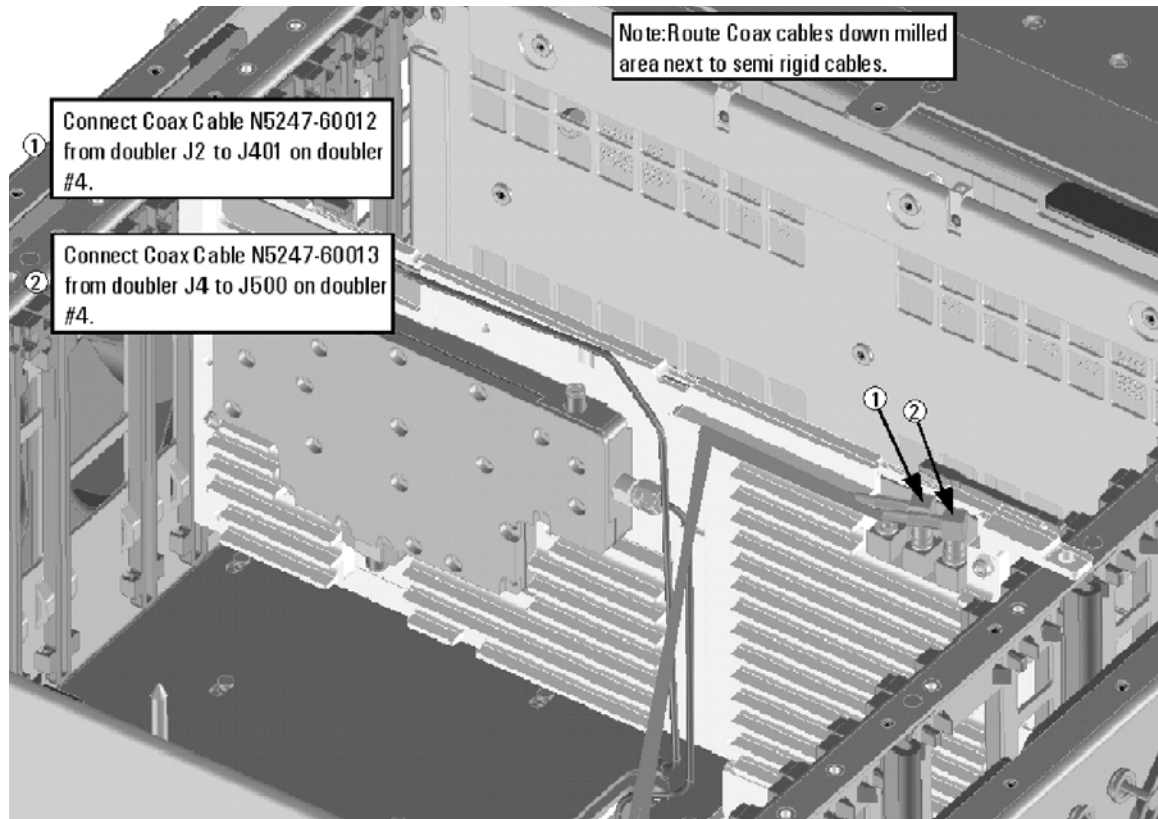

N5247_102_07

Step 23. Install a Bracket to the A10 Source Assembly

Follow the two instructions shown in [Figure 15](#).

Figure 15 A10 Source 2 Assembly Bracket Installation

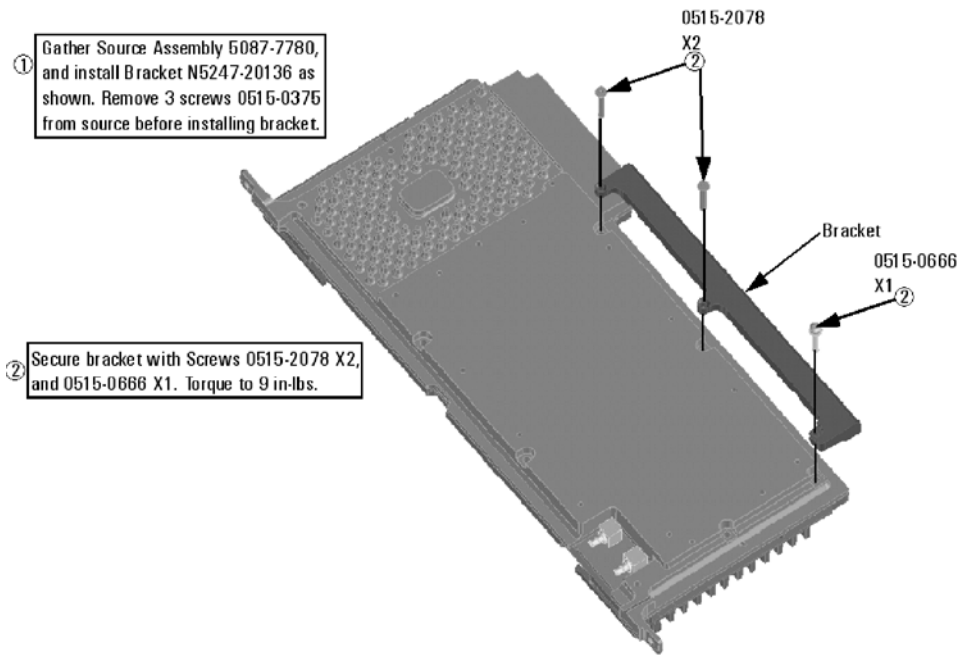

N5247_106_39

Step 24. Assemble the A10 26.5 GHz Source 2 Assembly

Follow the four instructions shown in [Figure 16](#).

Figure 16 A10 Source 2 Assembly

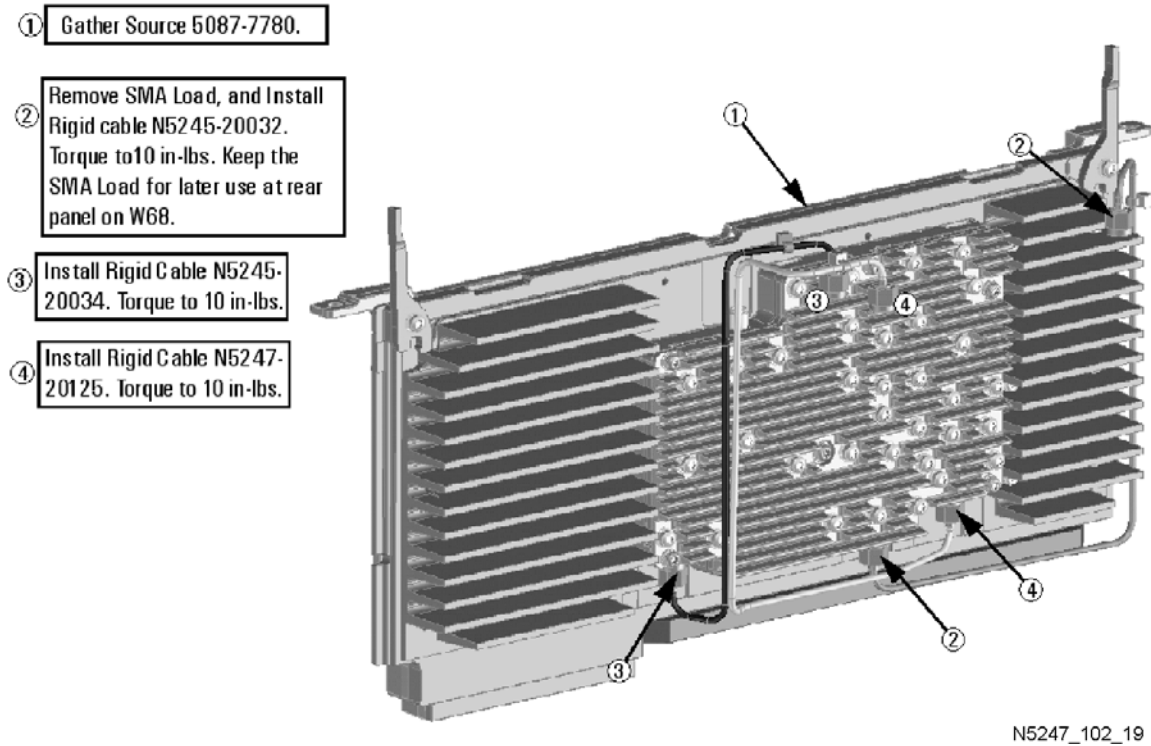

Step 25. Install the A10 26.5 GHz Source 2 Assembly and Cables

Follow the four instructions shown in [Figure 17](#).

Figure 17 A10 Source 2 Assembly Installation

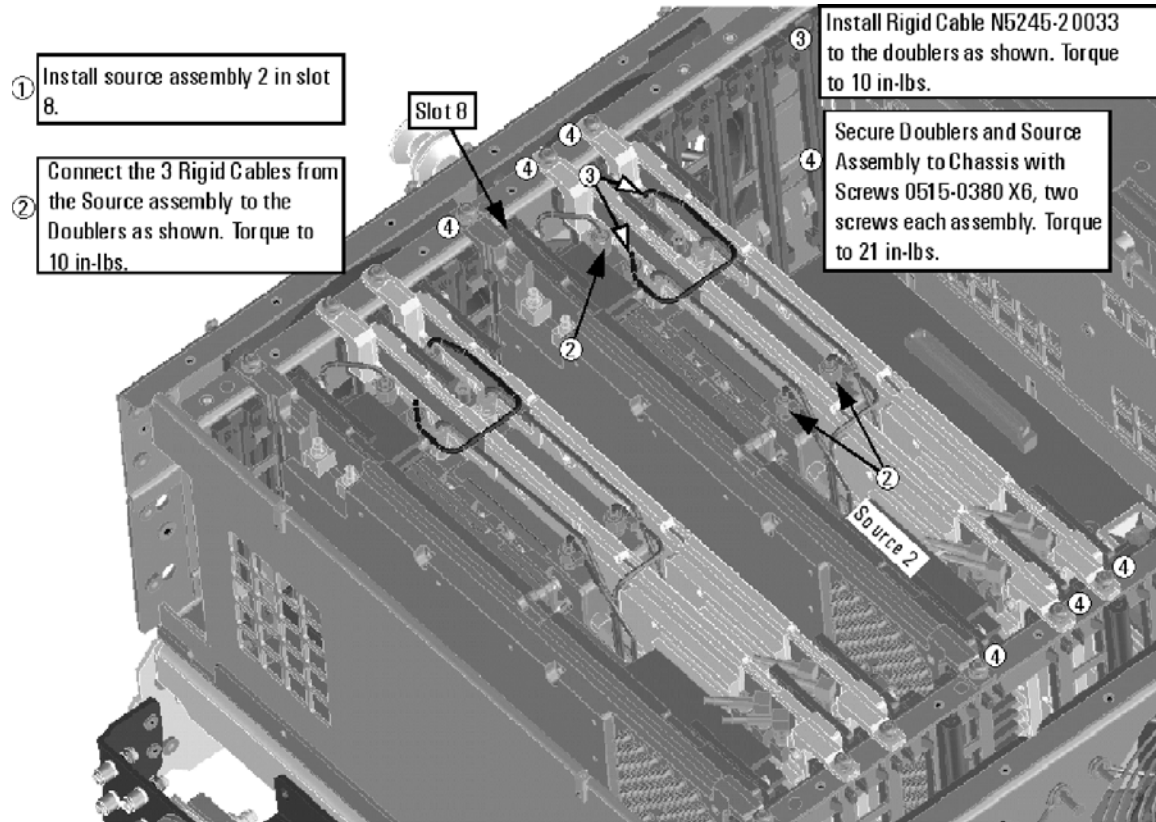

N5247_102_10

Step 26. Install the A17 13.5 GHz (Source 2) Synthesizer Board and Cables

1. Install new gray cable W87 (N5242-60030) to connector J5 of the new A17 (source 2) synthesizer board (N5240-60074). The loose end of the cable will be connected on the A14 frequency reference board (J7) after the A17 board has been installed in the analyzer.
2. Install the A17 board into slot 2 in the motherboard. Secure the board into the chassis using two screws (0515-0380). To see an image showing the location of the A17 board in the motherboard, click the Chapter 6 bookmark "Top Assemblies, All Options" in the PDF Service Guide¹.
3. Connect cable W2 (N5245-20100) between the A10 source 2 board and the A17 (source 2) synthesizer board, positioning the cable in the wire looms. Tighten the cable connectors to 10 in-lbs using a 5/16-in torque wrench.
4. Connect the loose end of new gray flex cable W87 (N5242-60030) on the A14 frequency reference board (J7). (The other end of this cable was previously connected to J5 of the source 2 synthesizer board.)

Step 27. Install the Cable Bracket Mount

1. Follow the two instructions shown in [Figure 18](#). New parts are listed in [Table 1 on page 7](#) of this document.

Figure 18 Cable Bracket Mount Installation

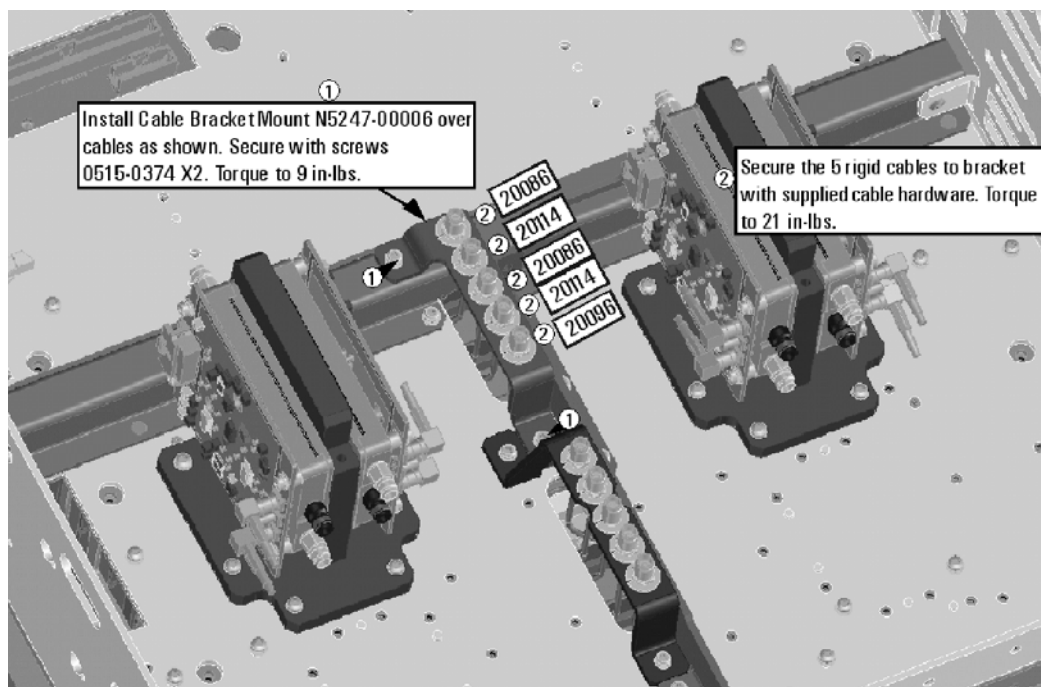

N5247_102_11

1. See ["Downloading the Online PNA Service Guide"](#) on page 5.

Step 28. Install the Cables

CAUTION Follow instructions carefully when making cable connections, especially wire harness connections. Incorrect connections can destroy components, resulting in additional customer costs.

CAUTION Be careful not to damage the center pins of the semirigid cables. Some flexing of the cables may be necessary but do not over-bend them.

Install the Semirigid Cables

To see an image showing the location of these cables, click the Chapter 6 bookmarks “Bottom RF Cables, 2-Port Configuration, Option 224” in the PDF Service Guide¹. New parts are listed in [Table 1 on page 7](#).

Install the following cables in the order listed.

- W142 (N5247-20089) A53 port 2 mechanical switch to PORT 2 TSET IN (J1)
 - W141 (N5247-20099) A53 port 2 mechanical switch to PORT 2 SW SRC OUT (J2)
 - W68 (N5247-20088) Rear-panel port RF2 OUT (J12) to W67
 - W134 (N5247-20095) Rear-panel PORT 3 SW TSET IN (J7) to A51 SRC2 OUT1 mechanical switch
- * As shown in [Figure 19](#), install three clamps (part number 1400-1334) to secure W68 (N5247-20088) and W134 (N5247-20095).

1. See [“Downloading the Online PNA Service Guide” on page 5](#).

Figure 19 Location of Cable Clamps to Secure W68 (N5247-20088) and W134 (N5247-20095)

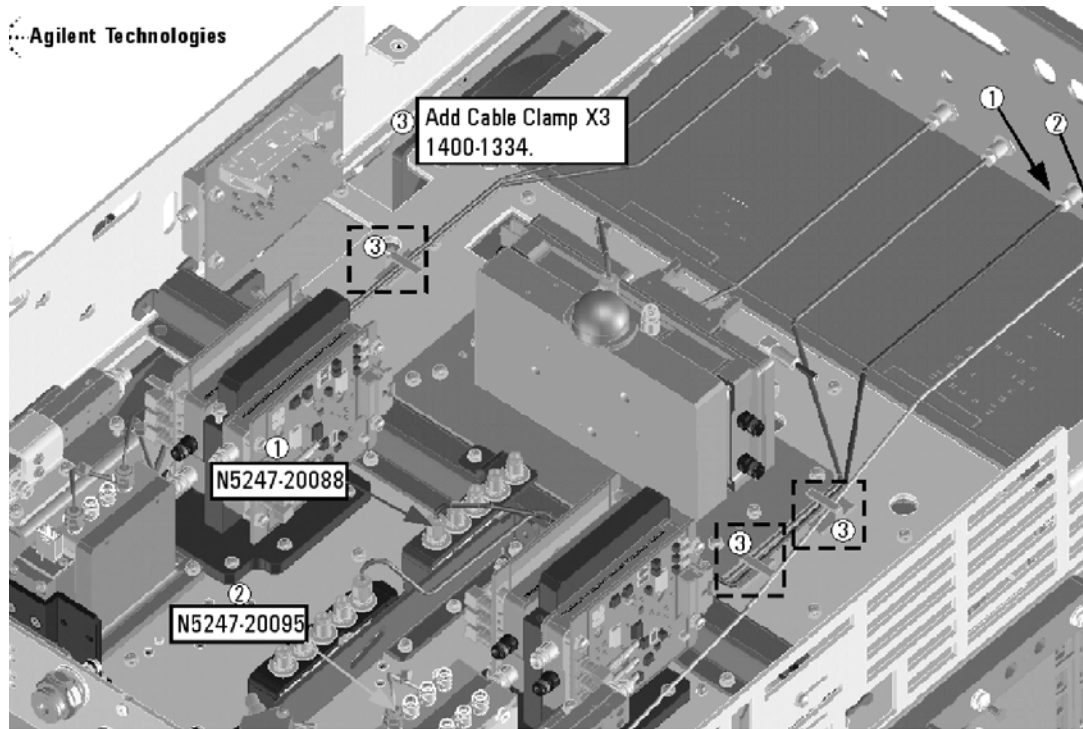

- W124 (reuse) (N5247-20046) A49 port 2 receiver attenuator to A27 mixer brick (B)
- W153 (reuse) (N5247-20045) A27 mixer brick (R2) to front-panel REF 2 RCVR R2 IN

* As shown in [Figure 20](#), install two clamps (part number 1400-1334) to secure W153 (N5247-20045).

Figure 20 Location of Cable Clamps to Secure W153 (N5247-20045)

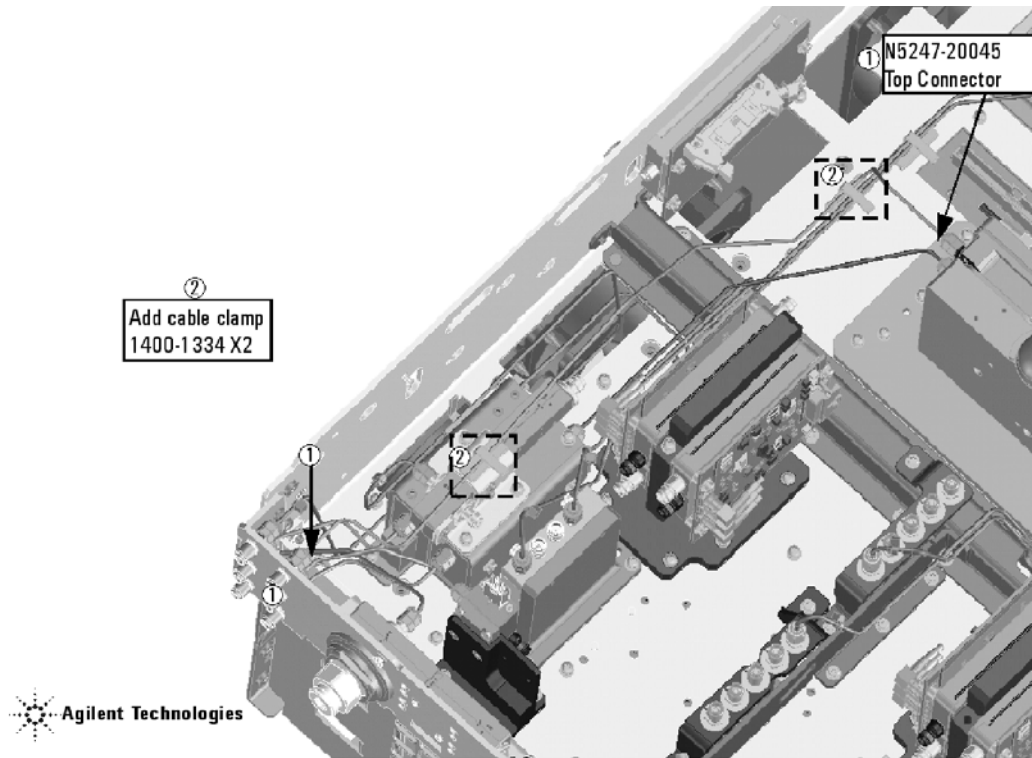

N5247_102_21

- W128 (N5247-20104) Front-panel PORT 1 COMB THRU IN to A54 combiner
- W129 (N5247-20103) Front-panel PORT 1 COMB ARM IN to A54 combiner
- W133 (N5247-20101) A51 SRC2 OUT1 mechanical switch to front panel SW SRC OUT
- W130 (N5247-20105) A50 port 1 mechanical switch to A54 combiner
- W132 (N5247-20038) Front-panel SRC2 OUT1 to A51 SRC2 OUT1 mechanical switch
- W53 (reuse) (N5247-20048) A37 reference mixer switch to A27 mixer brick (R1)
- W118 (reuse) (N5247-20047) A46 port 1 receiver attenuator to A27 mixer brick (A)
- W18 (N5247-20084) A61 port 3 70 GHz doubler to W17
- W126 (N5247-20031) A50 port 1 mechanical switch to A29 port 1 reference coupler
- W125 (N5247-20030) A50 port 1 mechanical switch to A60 port 1 70 GHz doubler
- W16 (N5247-20060) A61 port 3 70 GHz doubler to W15
- W131 (N5247-20032) A51 SRC2 OUT1 mechanical switch to A61 port 3 70 GHz doubler
- W12 (reuse) (N5247-20059) A60 port 1 70 GHz doubler to W11
- W127 (N5247-20102) A50 port 1 mechanical switch to PORT 1 SW SRC OUT
- W22 (N5247-20068) A62 port 4 70 GHz doubler to W21
- W29 (N5247-20106) Front-panel SRC2 OUT2 to A62 port 4 70 GHz doubler

- W20 (N5247-20015) A62 port 4 70 GHz doubler to W19
- W24 (reuse) (N5247-20061) A62 port 4 70 GHz doubler to W19
- W138 (N5247-20032) A53 port 2 mechanical switch to A63 70 GHz doubler
- W140 (N5247-20033) A53 port 2 mechanical switch to A32 port 2 reference coupler

Step 29. Install Rear Panel Hardware

Follow the four instructions shown in [Figure 21](#).

NOTE Two hole plugs (6960-0523) remain in the rear panel.

Figure 21 Rear Panel Hardware

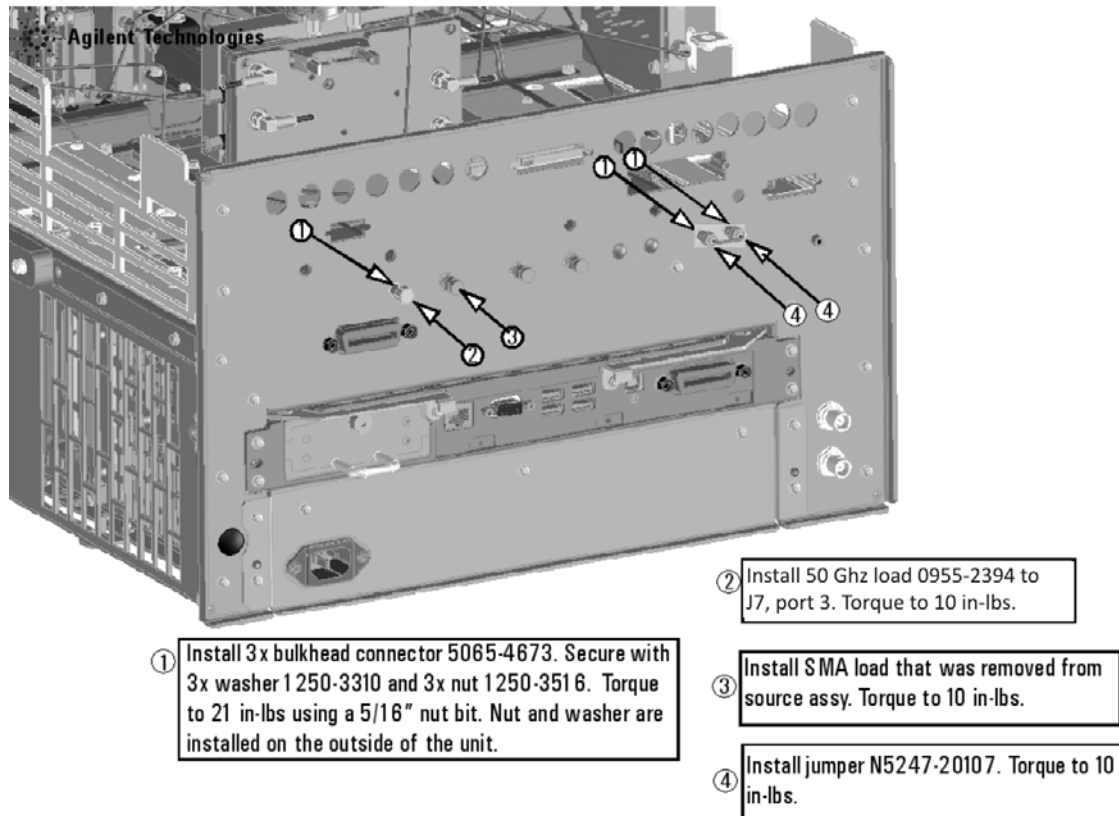

N5247_102_18

Step 30. Reinstall the A24 IF Multiplexer Board

For instructions, click the Chapter 7 bookmark "Removing and Replacing the A24 IF Multiplexer Board" in the PDF Service Guide¹.

Step 31. Reinstall the A23 Test Set Motherboard

For instructions on reinstalling the board, click the Chapter 7 bookmark “Removing and Replacing the A23 test set motherboard” in the PDF Service Guide¹.

Step 32. Install Cables on the A23 Test Set Motherboard

CAUTION Follow instructions carefully when making cable connections, especially wire harness connections. Incorrect connections can destroy components, resulting in additional customer costs.

If not already done in a previous step, install the following new wire harnesses and ribbon cables in the order listed. To see an image showing their location, click the Chapter 6 bookmark “Bottom Ribbon Cables and Wire Harnesses, 4-Port, Option 423” in the PDF Service Guide¹. New parts are listed in [Table 1 on page 7](#).

- Ribbon cable, A23 test set motherboard J5 to A61 port 3 70 GHz doubler
- Ribbon cable, A23 test set motherboard J3 to A62 port 4 70 GHz doubler
- Wire harness (part of mechanical switch assembly), A23 test set motherboard J101 to A50 port 1 mechanical switch
- Wire harness (part of mechanical switch assembly), A23 test set motherboard J102 to A51 SRC2 OUT1 mechanical switch
- Wire harness (part of mechanical switch assembly), A23 test set motherboard J104 to A53 port 2 mechanical switch

Step 33. Reinstall the Braces on the Bottom Side of the PNA

Reinstall the center brace and the two side braces on the bottom side of the PNA. Reuse all of the original parts you saved earlier in the procedure.

1. See [“Downloading the Online PNA Service Guide” on page 5](#).

Step 34. Replace the Lower Front Panel Overlay

Refer to [Figure 22](#) for this step of the procedure. New parts are listed in [Table 1 on page 7](#).

1. From the back side of the front panel, use a blunt object in the cutouts in the lower front dress panel to push on the old overlay (item ①) and separate it from the front dress panel.
2. From the front side of the front panel, pull off the overlay completely and discard it.
3. Remove any adhesive remaining on the front panel.
4. Install two 0515-1946 screws, one on either side of the new 1.85 mm male bulkhead connectors. Torque to 9 in-lbs.
5. Remove the protective backing from the new front panel overlay, N5247-80001 (item ②).
6. Starting from either side, *loosely* place the overlay in the recess on the lower front panel, ensuring that it fits tightly against the edges of the recess.
7. Once the overlay is in place, press it firmly onto the frame to secure it.

Figure 22 Lower Front Panel Overlay Replacement

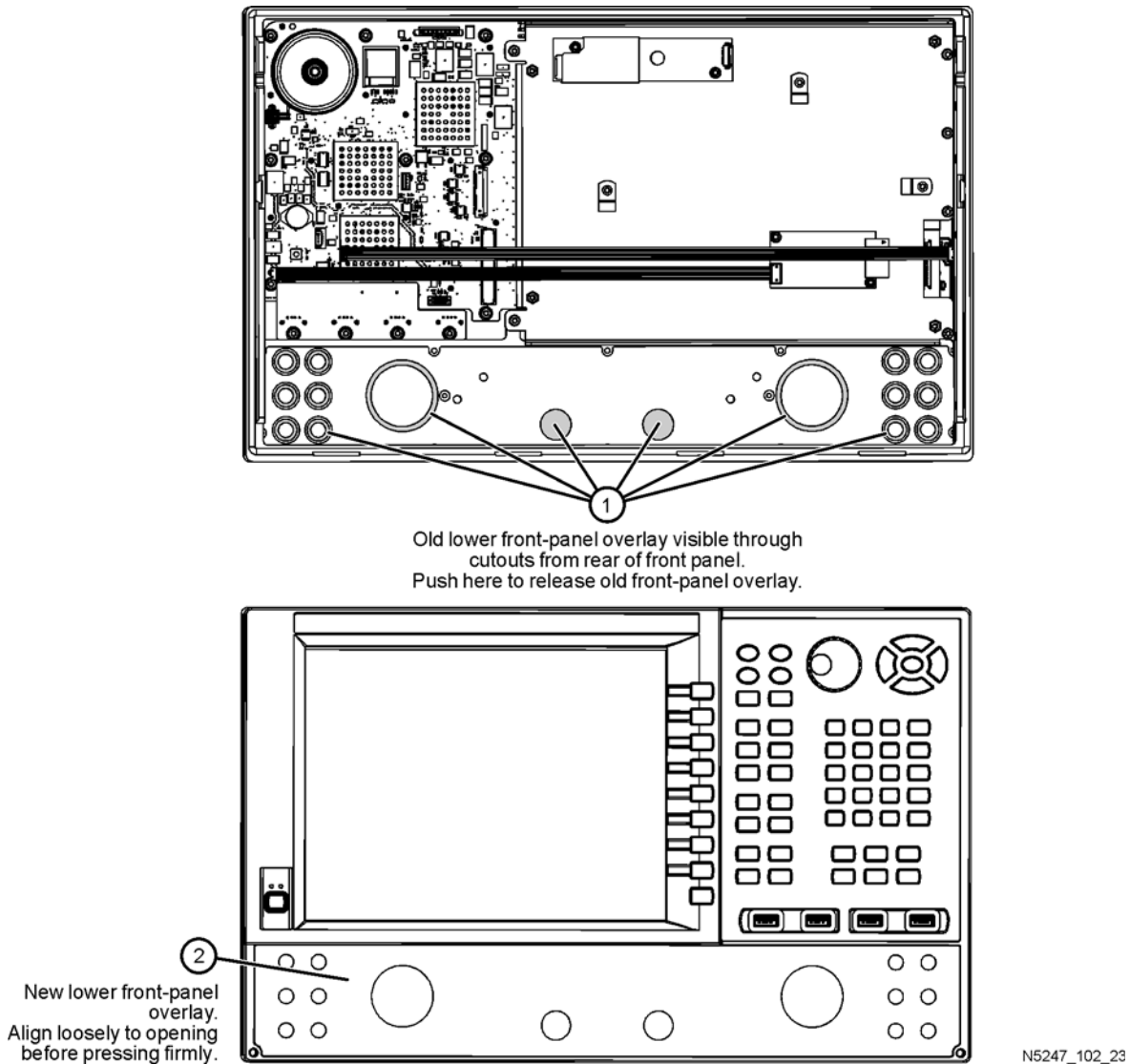

Step 35. Reinstall Front Panel Assembly

For instructions on reinstalling the front panel assembly, click the Chapter 7 bookmark "Removing and Replacing the Front Panel Assembly" in the PDF Service Guide¹.

Step 36. Install the New Front Panel Jumper Cables

Install two new jumper cables, N5247-20107, on the front panel. To see an image of the front panel jumper cables, click the Chapter 7 bookmark "Removing and Replacing the Front Panel Assembly" in the PDF Service Guide¹.

Step 37. Position the Cables and Wires to Prevent Pinching

On the top side of the PNA, carefully position the grey flex cables so they can't be pinched between the covers

and the rails.

On the bottom side of the PNA, carefully fold or push down the ribbon cables and wires so they can't be pinched between the hardware and the outer cover. Ribbon cables and wires must never be positioned on top of hardware.

Step 38. Reinstall the Inner Cover

For instructions, click the Chapter 7 bookmark "Removing the Covers" in the PDF Service Guide¹.

Step 39. Reinstall the Outer Cover

For instructions, click the Chapter 7 bookmark "Removing the Covers" in the PDF Service Guide¹.

Step 40. Enable Option 224

Procedure Requirements

- The analyzer must be powered up and operating to perform this procedure.
- The Network Analyzer program must be running.
- A keyboard must be connected to the network analyzer.

Option Enable Procedure

1. To start the option enable utility, press UTILITY **System**, then **Service**, then **Option Enable**. An option enable dialog box will appear.
2. Click the arrow in the **Select Desired Option** box. A list of available options will appear.
3. In the **Select Desired Option** list, click **224 - 2nd Src w/ Combiner & Switches**.
4. Using the keyboard, enter the license key in the box provided. The license key is printed on the license message you received from Keysight. Enter this key *exactly* as it is printed on the message.
5. Click **Enable**.
6. Click **Yes** in answer to the displayed question in the **Restart Analyzer?** box.
7. When the installation is complete, click **Exit**.

Option Verification Procedure

Once the analyzer has restarted and the Network Analyzer program is again running:

1. On the analyzer's **Help** menu, click **About Network Analyzer**.
2. Verify that "224" is listed after "Options:" in the display. Click **OK**.

NOTE If Option 224 has not been enabled, perform the "Option Enable Procedure" again. If the option is still not enabled, contact Keysight Technologies. Refer to "Getting Assistance from Keysight" on page 3.

1. See "Downloading the Online PNA Service Guide" on page 5.

Step 41. Perform Post-Upgrade Adjustments and Calibration

Adjustments

The following adjustments must be made due to the hardware changes of the analyzer.

- default EE
- source adjustment
- receiver adjustment

These adjustments are described in the PNA Service Guide and in the PNA on-line HELP. A list of equipment required to perform these adjustments is also found in the service guide.

To view this service guide information, click the Chapter 3 bookmark “Tests and Adjustments” in the PDF Service Guide¹.

After the specified adjustments have been performed, the analyzer should operate and phase lock over its entire frequency range.

Operator’s Check

Perform the Operator’s Check to check the basic functionality of the analyzer. For instructions, click the Chapter 3 bookmark “Tests and Adjustments” in the PDF Service Guide¹.

If you experience difficulty with the basic functioning of the analyzer, contact Keysight. Refer to [“Contacting Keysight” on page 3](#).

Calibration

Although the analyzer functions, its performance relative to its specifications has not been verified. It is recommended that a full instrument calibration be performed using the analyzer’s internal performance test software. To view information on the performance test software, click the Chapter 3 bookmark “Tests and Adjustments” in the PDF Service Guide¹.

Step 42. Prepare the PNA for the User

1. If necessary, reinstall front jumper cables.
2. Install the cable guards, pushing them over the front jumper cables until the cushioning material touches the front panel of the PNA.
3. Install the dust caps on the test ports.
4. Clean the analyzer, as needed, using a damp cloth.

1. See [“Downloading the Online PNA Service Guide” on page 5](#).

This information is subject to change without notice.

© Keysight Technologies 2011 - 2014

December 1, 2014



N5247-90102
www.keysight.com