

# Keysight Add 4-Port Capability Upgrade Kit

To Upgrade PNA-X N5247A Option 200 to Option 400

Upgrade Kit Order Number: N5247AU- 940

Keysight Kit Number: N5247-60105

NOTICE: This document contains references to Agilent Technologies. Agilent's former Test and Measurement business has become Keysight Technologies. For more information, go to [www.keysight.com](http://www.keysight.com).



---

## WARRANTY STATEMENT

THE MATERIAL CONTAINED IN THIS DOCUMENT IS PROVIDED "AS IS," AND IS SUBJECT TO BEING CHANGED, WITHOUT NOTICE, IN FUTURE EDITIONS. FURTHER, TO THE MAXIMUM EXTENT PERMITTED BY APPLICABLE LAW, KEYSIGHT DISCLAIMS ALL WARRANTIES, EITHER EXPRESS OR IMPLIED WITH REGARD TO THIS MANUAL AND ANY INFORMATION CONTAINED HEREIN, INCLUDING BUT NOT LIMITED TO THE IMPLIED WARRANTIES OF MERCHANTABILITY AND FITNESS FOR A PARTICULAR PURPOSE. KEYSIGHT SHALL NOT BE LIABLE FOR ERRORS OR FOR INCIDENTAL OR CONSEQUENTIAL DAMAGES IN CONNECTION WITH THE FURNISHING, USE, OR PERFORMANCE OF THIS DOCUMENT OR ANY INFORMATION CONTAINED HEREIN. SHOULD KEYSIGHT AND THE USER HAVE A SEPARATE WRITTEN AGREEMENT WITH WARRANTY TERMS COVERING THE MATERIAL IN THIS DOCUMENT THAT CONFLICT WITH THESE TERMS, THE WARRANTY TERMS IN THE SEPARATE AGREEMENT WILL CONTROL.

---

## DFARS/Restricted Rights Notice

If software is for use in the performance of a U.S. Government prime contract or subcontract, Software is delivered and licensed as "Commercial computer software" as defined in DFAR 252.227-7014 (June 1995), or as a "commercial item" as defined in FAR 2.101(a) or as "Restricted computer software" as defined in FAR 52.227-19 (June 1987) or any equivalent agency regulation or contract clause. Use, duplication or disclosure of Software is subject to Keysight Technologies' standard commercial license terms, and non-DOD Departments and Agencies of the U.S. Government will receive no greater than Restricted Rights as defined in FAR 52.227-19(c)(1-2) (June 1987). U.S. Government users will receive no greater than Limited Rights as defined in FAR 52.227-14 (June 1987) or DFAR 252.227-7015 (b)(2) (November 1995), as applicable in any technical data.

---

## Safety Notes

The following safety notes are used throughout this document. Familiarize yourself with each of these notes and its meaning before performing any of the procedures in this document.

---

**WARNING**      **Warning denotes a hazard. It calls attention to a procedure which, if not correctly performed or adhered to, could result in injury or loss of life. Do not proceed beyond a warning note until the indicated conditions are fully understood and met.**

---

---

**CAUTION**      Caution denotes a hazard. It calls attention to a procedure that, if not correctly performed or adhered to, could result in damage to or destruction of the instrument. Do not proceed beyond a caution sign until the indicated conditions are fully understood and met.

---

---

## Description of the Upgrade

This upgrade converts your N5247A Option 200 2-port analyzer to an N5247A Option 400 4-port analyzer by adding:

- an additional 26.5 GHz source board
- an additional 13.5 GHz source synthesizer board
- two additional 40 GHz doublers
- two additional 70 GHz doublers
- an additional mixer brick
- two additional reference couplers and brackets
- two additional test port couplers
- an additional cable guard for front panel jumpers
- a splitter
- a 3 dB pad
- a modified front panel
- many additional new cables

---

## Getting Assistance from Keysight

Installing this upgrade kit requires special skills and experience. If you think you may not be qualified to do the work, or need advice, contact Keysight.

### Contacting Keysight

Assistance with test and measurements needs and information on finding a local Keysight office are available on the Web at:

<http://www.keysight.com/find/assist>

If you do not have access to the Internet, please contact your Keysight field engineer.

---

**NOTE** In any correspondence or telephone conversation, refer to the Keysight product by its model number and full serial number. With this information, the Keysight representative can determine whether your product is still within its warranty period.

---

---

## Getting Prepared

---

### CAUTION

The PNA contains extremely sensitive components that can be ruined if mishandled. Follow instructions carefully when making cable connections, especially wire harness connections.

The person performing the work accepts responsibility for the full cost of the repair or replacement of damaged components.

---

To successfully install this upgrade kit, you will need the following:

- A license key - refer to “[License Key Redemption](#)” below.
- A PDF copy or a paper copy of the PNA Service Guide - refer to “[Downloading the Online PNA Service Guide](#)” below.
- An ESD-safe work area - refer to “[Protecting Your Workspace from Electrostatic Discharge](#)” below.
- Correct tools - refer to “[Tools Required for the Installation](#)” on page 6.
- Enough time - refer to “[About Installing the Upgrade](#)” on page 6.
- Test equipment for the post-upgrade adjustments and full instrument calibration. To view the equipment list, click the Chapter 3 bookmark “[Tests and Adjustments](#)” in the PDF Service Guide<sup>1</sup>.

## License Key Redemption

---

### NOTE

The enclosed Option Entitlement Certificate is a receipt, verifying that you have purchased a licensed option for the PNA of your choice. You must now use a Keysight Web page to request a license key for the instrument that will receive the option.

---

To enable the option product, you must request a license key from: <http://www.keysight.com/find/softwarelicense>. To complete the request, you will need to gather the following information:

- From the certificate
  - Order number
  - Certificate number
- From your instrument
  - Model number
  - Serial number
  - Host ID

The instrument information is available on the network analyzer – on the analyzer’s **Help** menu, click **About Network Analyzer**.

If you provide an email address, Keysight will promptly email your license key. Otherwise, you will your receive

---

1. See “[Downloading the Online PNA Service Guide](#)” on page 5.

your license key via postal mail.

## Downloading the Online PNA Service Guide

To view the online Service Guide for your PNA model number, use the following steps:

1. Go to [www.keysight.com](http://www.keysight.com).
2. In the Search box, enter the model number of the analyzer (Ex: N5247A) and click **Search**.
3. Click **Technical Support > Manuals**.
4. Click **Service Manual**.
5. Click the service guide title to download the PDF file.
6. When the PDF of the Service Guide is displayed, scroll through the Contents section bookmarks to locate the information needed.

## Protecting Your Workspace from Electrostatic Discharge

For information, click on the Chapter 1 bookmark, “Electrostatic Discharge Protection” in the PDF Service Guide<sup>1</sup>.

### ESD Equipment Required for the Installation

Description	Keysight Part Number
ESD grounding wrist strap	9300-1367
5-ft grounding cord for wrist strap	9300-0980
2 x 4 ft conductive table mat and 15-ft grounding wire	9300-0797
ESD heel strap (for use with conductive floors)	9300-1308

1. See “[Downloading the Online PNA Service Guide](#)” on page 5.

## Tools Required for the Installation

Description	Qty	Part Number
T-6 TORX driver - set to 4 in-lbs (0.45 N.m)	1	N/A
T-8 TORX driver - set to 6 in-lbs (0.68 N.m)	1	N/A
T-10 TORX driver - set to 9 in-lbs (1.02 N.m)	1	N/A
T-20 TORX driver - set to 21 in-lbs (2.38 N.m)	1	N/A
5/16-in (8 mm) nutsetter or open end torque wrench- set to 10 in-lbs (1.13 N.m)	1	N/A
5/16-in (8 mm) nutsetter or open end torque wrench - set to 21 in-lbs (2.38 N.m)	1	N/A
3/16-in (5 mm) nutsetter or open end torque wrench - set to 6 in-lbs (0.68 N.m)	1	N/A
5/8-in (16 mm) nutsetter or open end torque wrench - set to 21 in-lbs (2.38 N.m)	1	N/A
9 mm nutsetter or open end torque wrench - set to 21 in-lbs (2.38 N.m)	1	N/A
1-in (25.4 mm) torque wrench - set to 72 in-lbs (8.15 N.m)	1	N/A
1/4-in (6 mm) open end wrench	1	N/A

**CAUTION** Use a 5/16-in torque wrench set to 10 in-lbs on all cable connections except the front and rear panel cable connectors. On these, use a 9 mm nutsetter or open end torque wrench set to 21 in-lb.

## About Installing the Upgrade

Products affected . . . . .	N5247A Option 200
Installation to be performed by . . . . .	Keysight service center or personnel qualified by Keysight
Estimated installation time . . . . .	5 hours
Estimated adjustment time . . . . .	0.5 hours
Estimated full instrument calibration time . . . . .	4.5 hours

## Items Included in the Upgrade Kit<sup>1</sup>

Check the contents of your kit against the following list. If any part is missing or damaged, contact Keysight Technologies. Refer to [“Contacting Keysight” on page 3](#).

**Table 1 Contents of Upgrade Kit N5247-60105**

Ref Desig.	Description	Qty	Part Number
-	Installation note (this document)	1	N5247-90105
A10	26.5 GHz source (2) board	1	5087-7780
A12	40 GHz doubler assembly port 3	2	5087-7346
A13	40 GHz doubler assembly port 4		
A17	13.5 GHz (source 2) synthesizer board	1	N5240-60074 Was N5242-60150
A26	Splitter	1	5067-4086
A28	Mixer brick (2)	1	5087-7337
A30	Test port 3 reference coupler	2	5087-7744
A31	Test port 4 reference coupler		
A34	Test port 3 coupler	2	5087-7778
A35	Test port 4 coupler		
A61	Test port 3 70 GHz doubler assembly	2	5087-7336
A62	Test port 4 70 GHz doubler assembly		
A69	3 dB pad, attached to R4 connector on A28 mixer brick	1	08490-60037
-	Front frame, 4-port	1	N5247-20141
-	Bulkhead connector, front panel	12	5065-4673
-	Washer for bulkhead connectors, front panel	12	1250-3310
-	Nut for bulkhead connectors, front panel	12	1250-3516
-	Machine screw, M2.0 x 6, flat head (8 to attach 2 reference couplers to brackets)	8	0515-0658
-	Machine screw, M2.5 x 20, pan head (2 to attach cable bracket mount to test set deck)	2	0515-0374
-	Machine screw, M2.5 x 20, pan head (6 to attach 2 70 GHz doublers to mounts)	6	0515-0375
-	Machine screw, M4.0 x 10, pan head (2 each to attach the following boards to the analyzer chassis: A17 13.5 GHz synthesizer board, A10 26.5 GHz source board, A12 40 GHz doubler assembly port 3, and A13 40 GHz doubler assembly port 4.)	8	0515-0380
-	Machine screw, M3.0 x 8, pan head (6 to attach port 3 and port 4 reference coupler assemblies to test set deck).	6	0515-0372
-	Machine screw, M2.5 x 16, pan head (2 to attach splitter to mixer brick)	2	0515-2007
-	Machine screw, M3.0 x 35, pan head (3 to attach A28 mixer brick to block)	3	0515-1038
-	Front panel overlay (label), 4-port	1	N5247-80011

1. In addition to the upgrade kit, the shipment includes an Option Entitlement Certificate. Refer to [“License Key Redemption” on page 4](#) for important information about this certificate.



**Table 1 Contents of Upgrade Kit N5247-60105**

Ref Desig.	Description	Qty	Part Number
-	Machine screw, M3.0 x 20, flat head (2 to attach bracket to A10 26.5 GHz source)	2	0515-2078
-	Machine screw, M3.0 x 18, pan head (1 to attach bracket to A10 26.5 GHz source)	1	0515-0666
-	Keypad overlay (label)	1	N5242-80005
-	Power button overlay (label)	1	N5242-80007
-	Nameplate, N5247A	1	N5242-80006
-	Test set front plate, 4-port	1	N5247-00009
-	Protective cap, black plastic	2	1401-0214
-	Pad (between each reference coupler and the bracket for the attenuator pairs)	2	0403-0179
-	Gap pad (between each test coupler and the test set front plate)	4	E4403-20033
-	Vibration mount (between couplers 1 & 3, and 2 & 4)	2	0460-2725
-	Mounting nuts (for port 3 & 4 test port couplers)	2	5022-1087
-	Cable guard, center jumper cables	1	N5242-00030
-	Cable clamp, 2 to secure W45 (N5247-20076); 1 to secure W41 (N5247-20075); 1 to secure W37 (N5247-20077); 1 to secure W33 (N5247-20078).	5	1400-1334
-	Cable tie wrap, 1 to secure W93 (N5247-60010) and W94 (N5247-60011) cable ends together; 1 to secure W95 (N5247-60012) and W96 (N5247-60013) cable ends together; 1 to secure W14 (N5247-20072), W18 (N5247-20084) and W54 (N5247-20062)	3	1400-0249
-	Bracket, rear, bottom side - for semi rigid cables	1	N5247-00006
-	Bracket for reference coupler, port 3	1	N5247-00012
-	Bracket for reference coupler, port 4	1	N5247-00011
-	Bracket for A10 26.5 GHz source (2) board	1	N5247-20136
W2	RF cable, A10 source (2) P1 to A17 13.5 GHz source (2) synthesizer J1207	1	N5245-20100
W7	RF cable, A10 source (2) P5 to A12 port 3 40 GHz doubler P1	1	N5245-20034
W8	RF cable, A10 source (2) P3 to A13 port 4 40 GHz doubler P1	1	N5247-20125
W9	RF cable, A10 source (2) P4 to A12 port 3 40 GHz doubler P4	1	N5245-20032
W10	RF cable, A12 port 3 40 GHz doubler P3 to A13 port 4 40 GHz doubler P4	1	N5245-20033
W15	RF cable, A12 port 3 40 GHz doubler P6 to W16	1	N5247-20114
W16	RF cable, A61 port 3 70 GHz doubler to W15	1	N5247-20060
W17	RF cable, A12 port 3 40 GHz doubler P2 to W18	1	N5247-20086
W18	RF cable, A61 port 3 70 GHz doubler to W17	1	N5247-20084
W19	RF cable, A13 port 4 40 GHz doubler P6 to W20	1	N5247-20114
W20	RF cable, A62 port 4 70 GHz doubler to W19	1	N5247-20015
W21	RF cable, A13 port 4 40 GHz doubler P2 to W22	1	N5247-20086
W22	RF cable, A62 port 4 70 GHz doubler to W21	1	N5247-20068
W28	RF cable, A61 port 3 70 GHz doubler to A30 port 3 reference coupler	1	N5247-20052
W29	RF cable, A62 port 4 70 GHz doubler to A31 port 4 reference coupler	1	N5247-20074
W32	RF cable, port 1 CPLR THRU to A33 port 1 coupler	1	N5247-20016

**Table 1 Contents of Upgrade Kit N5247-60105**

<b>Ref Desig.</b>	<b>Description</b>	<b>Qty</b>	<b>Part Number</b>
W33	RF cable, A29 port 1 reference coupler to A37 reference mixer switch	1	N5247-20078
W34	RF cable, A33 port 1 coupler to front-panel Port 1 CPLR ARM	1	N5247-20082
W35	RF cable, A30 port 3 ref coupler to front-panel port 3 SOURCE OUT	1	N5247-20023
W36	RF cable, Port 3 CPLR THRU to A34 port 3 coupler	1	N5247-20006
W37	RF cable, A30 port 3 ref coupler to front-panel REF 3 SOURCE OUT	1	N5247-20077
W38	RF cable, A34 port 3 coupler to front-panel Port 3 CPLR ARM	1	N5247-20007
W39	RF cable, A31 port 4 ref coupler to front-panel port 4 SOURCE OUT	1	N5247-20035
W40	RF cable, port 4 CPLR THRU to A35 port 4 coupler	1	N5247-20017
W41	RF cable, A31 port 4 ref coupler to front-panel REF 4 SOURCE OUT	1	N5247-20075
W42	RF cable, A35 port 4 coupler to front-panel Port 4 CPLR ARM	1	N5247-20026
W44	RF cable, port 2 CPLR THRU to A36 port 2 coupler	1	N5247-20018
W45	RF cable, A32 port 2 ref coupler to front-panel REF 2 SOURCE OUT	1	N5247-20076
W46	RF cable, A36 port 2 coupler to front-panel port 2 CPLR ARM	1	N5247-20019
W48	RF cable, port 3 RCVR C IN to A28 mixer brick (C)	1	N5247-20063
W49	RF cable, port 4 RCVR D IN to A28 mixer brick (D)	1	N5247-20073
W54	RF cable, REF 3 RCVR R3 IN to A28 mixer brick (R3)	1	N5247-20062
W55	RF cable, REF 4 RCVR R4 IN to A28 mixer brick (R4)	1	N5247-20067
W58	RF cable, 2.4 mm cap for A28 mixer brick	1	N5247-20138
W60	RF cable, front panel jumper	6	N5247-20107
W62	RF cable, A25 HMA26.5 to A26 splitter	1	N5247-20111
W63	RF cable, A26 splitter to A27 mixer brick	1	N5245-20023
W64	RF cable, A26 splitter to A28 mixer brick	1	N5245-20022
W67	RF cable, A12 port 3 40 GHz doubler P5 to W68	1	N5247-20096
W68	RF cable, rear-panel port RF2 OUT (J12) to W67	1	N5247-20088
W72	RF cable, A27 mixer brick (R1) to A24 IF multiplexer (P411)	1	N5242-60021
W73	RF cable, A27 mixer brick (R2) to A24 IF multiplexer (P412)	1	N5242-60022
W75	RF cable, A28 mixer brick (D) to A24 IF multiplexer (P801)	1	N5242-60024
W76	RF cable, A28 mixer brick (R4) to A24 IF multiplexer (P414)	1	N5242-60019
W77	RF cable, A28 mixer brick (R3) to A24 IF multiplexer (P413)	1	N5242-60020
W78	RF cable, A28 mixer brick (C) to A24 IF multiplexer (P601)	1	N5242-60023
W80	RF cable, A24 IF multiplexer board P203 to A16 SPAM board J2	1	N5242-60013
W82	RF cable, A24 IF multiplexer board P603 to A16 SPAM board J5	1	N5242-60015
W87	RF cable, A14 frequency ref (J7) to A17 13.5 GHz (source 2) synth (J5)	1	N5242-60030
W93	RF cable, A61 port 3 70 GHz dblr J2 to A12 40 GHz dblr J401	1	N5247-60010
W94	RF cable, A61 port 3 70 GHz dblr J4 to A12 40 GHz dblr J500	1	N5247-60011
W95	RF cable, A62 port 4 70 GHz doubler (J2) to A13 40 GHz doubler (J401)	1	N5247-60012
W96	RF cable, A62 port 4 70 GHz dblr J4 to A13 40 GHz dblr J500	1	N5247-60013

**Table 1**      **Contents of Upgrade Kit N5247-60105**

<b>Ref Desig.</b>	<b>Description</b>	<b>Qty</b>	<b>Part Number</b>
-	Ribbon cable, A23 test set motherboard J5 to A61 port 3 70 GHz doubler J1	2	N5247-60018
-	Ribbon cable, A23 test set motherboard J3 to A62 port 4 70 GHz doubler J1		
-	Ribbon cable, A23 test set motherboard J552 to A28 mixer brick (2) J52	1	N5247-60015

---

**NOTE**                      Extra quantities of items such as protective plastic caps, screws, cable ties, and cable clamps are included in this upgrade kit. It is normal for some of these items to remain unused after the upgrade is completed.

---

---

## Installation Procedure for the Upgrade

The network analyzer must be in proper working condition prior to installing this option. Any necessary repairs must be made before proceeding with this installation.

---

**WARNING**      **This installation requires the removal of the analyzer's protective outer covers. The analyzer must be powered down and disconnected from the mains supply before performing this procedure.**

---

### Overview of the Installation Procedure

- Step 1. Obtain a Keyword and Verify the Information.
- Step 2. Remove the Outer Cover.
- Step 3. Remove the Inner Cover.
- Step 4. Remove the Front Panel Jumper Cables and Cable Guards.
- Step 5. Remove the Front Panel Assembly.
- Step 6. Remove the A23 Test Set Motherboard.
- Step 7. Remove the Testset Stabilizer Bracket from the A24 IF Multiplexer Board.
- Step 8. Remove Some Bottom-Side (Test Set) Cables.
- Step 9. Remove the A60 70 GHz Doubler Assembly From the Test Set Deck.
- Step 10. Assemble the A61 70 GHz Doubler on the Doubler Mount.
- Step 11. Reinstall the A60/A61 70 GHz Doubler Assembly.
- Step 12. Remove the A63 70 GHz Doubler Assembly From the Test Set Deck.
- Step 13. Assemble the A62 70 GHz Doubler on the Doubler Mount.
- Step 14. Reinstall the A62/A63 70 GHz Doubler Assembly.
- Step 15. Assemble and Install the A12 40 GHz Doubler Assembly.
- Step 16. Install the A12 40 GHz Doubler Cables.
- Step 17. Assemble and Install the A13 40 GHz Doubler Assembly.
- Step 18. Install the A13 40 GHz Doubler Cables.
- Step 19. Install Bracket to A10 26.5 GHz Source 2 Assembly.
- Step 20. Assemble the A10 26.5 GHz Source 2 Assembly.
- Step 21. Install the A10 26.5 GHz Source 2 Assembly and Cables.
- Step 22. Install the A17 13.5 GHz (Source 2) Synthesizer Board and Cables.
- Step 23. Install the Cable Bracket Mount.
- Step 24. Remove the A27 Mixer Brick Assembly.
- Step 25. Assemble the A28 Mixer Brick Assembly.

- Step 26. Install the A27/A28 Mixer Brick Assemblies.
- Step 27. Assemble the A30 and A31 Reference Coupler Assemblies.
- Step 28. Install the A30 and A31 Reference Coupler Assemblies.
- Step 29. Assemble the A33 - A36 Test Port Coupler Assemblies.
- Step 30. Remove and Disassemble the 2-Port Test Set Front Plate.
- Step 31. Install the LED Boards, Bulkhead Connectors, and Test Port Coupler Assemblies to the 4-Port Test Set Front Plate.
- Step 32. Install the 4-Port Coupler Plate Assembly to the Deck.
- Step 33. Install Some Bottom-Side (Test Set) Cables.
- Step 34. Install Cables on IF Multiplexer Board.
- Step 35. Reinstall the Testset Stabilizer Bracket on the A24 IF Multiplexer Board.
- Step 36. Reinstall the A23 Test Set Motherboard.
- Step 37. Install Cables on the A23 Test Set Motherboard.
- Step 38. Replace the Front Frame in the Front Panel Assembly.
- Step 39. Reinstall Front Panel Assembly.
- Step 40. Install the Overlays and Nameplate.
- Step 41. Install the Jumper Cables.
- Step 42. Position the Cables and Wires to Prevent Pinching.
- Step 43. Reinstall the Inner Cover.
- Step 44. Reinstall the Outer Cover.
- Step 45. Install the Cable Guards Over the Front Panel Jumpers.
- Step 46. Enable Options P04 (400).
- Step 47. Perform Post-Upgrade Adjustments and Calibration.
- Step 48. Prepare the PNA for the User.

## **Step 1. Obtain a Keyword and Verify the Information**

Follow the instructions on the Option Entitlement Certificate supplied to obtain a license key for installation of this upgrade. Refer to [“License Key Redemption” on page 4](#).

Verify that the model number, serial number, and option number information on the license key match those of the instrument on which this upgrade will be installed.

If the model number, serial number, or option number do not match those on your license key, you will not be able to install the option. If this is the case, contact Keysight for assistance before beginning the installation of this upgrade. Refer to [“Contacting Keysight” on page 3](#).

Once the license key has been received and the information verified, you can proceed with the installation at step 2.

## **Step 2. Remove the Outer Cover**

For instructions, click the Chapter 7 bookmark “Removing the Covers” in the PDF Service Guide<sup>1</sup>.

## **Step 3. Remove the Inner Cover**

For instructions, click the Chapter 7 bookmark “Removing the Covers” in the PDF Service Guide<sup>1</sup>.

## **Step 4. Remove the Front Panel Jumper Cables and Cable Guards**

1. Pull the two cable guards off of the front panel jumper cables. Save them for reinstallation later.
2. Remove all front panel jumper cables. Keep for reinstallation later.

## **Step 5. Remove the Front Panel Assembly**

For instructions, click the Chapter 7 bookmark “Removing and Replacing the Front Panel Assembly” in the PDF Service Guide<sup>1</sup>.

## **Step 6. Remove the A23 Test Set Motherboard**

For instructions, click the Chapter 7 bookmark “Removing and Replacing the A23 Test Set Motherboard” in the PDF Service Guide<sup>1</sup>.

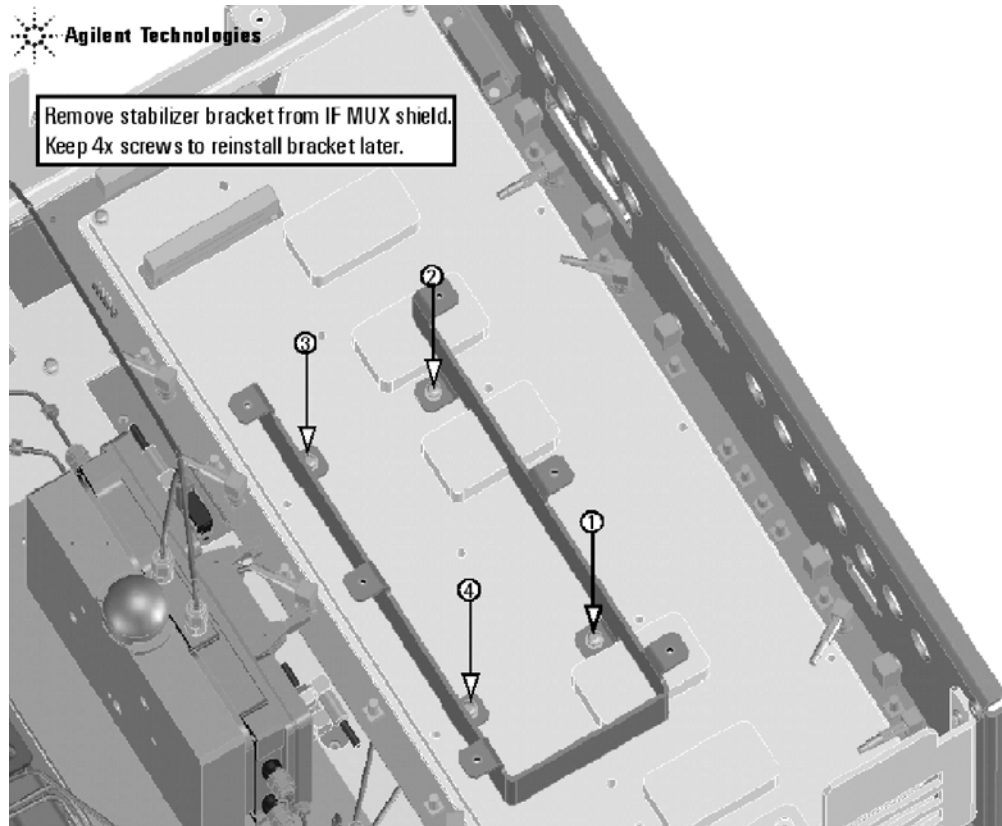
---

1. See [“Downloading the Online PNA Service Guide” on page 5](#).

## Step 7. Remove the Testset Stabilizer Bracket from the A24 IF Multiplexer Board

Remove the stabilizer bracket as shown in [Figure 1](#).

**Figure 1** Testset Stabilizer Bracket on A24 IF MUX Board



N5247\_105\_10

## Step 8. Remove Some Bottom-Side (Test Set) Cables

---

**CAUTION** Be careful not to damage the center pins of the semirigid cables. Some flexing of the cables may be necessary but do not over-bend them.

---

---

**NOTE** When removing a cable, also remove the plastic cable clamp, if present. It is normal for some of the cable clamp's adhesive to remain.

---

1. Place the analyzer bottom-side up on a flat surface.
2. Remove all bottom-side gray flexible cables and silver semi-rigid cables. Do not discard the cables (exception: see steps 3 and 4 below) that are removed because some will be reused later in the procedure. To see an image showing the location of cables, click the Chapter 6 bookmark "Bottom RF Cables, 2-Port, Option 200" in the PDF Service Guide<sup>1</sup>.
3. Remove and discard the following semi-rigid cables:
  - W34 (N5247-20039) A33 port 1 coupler to front panel port 1 CPLR ARM
  - W46 (N5247-20041) A36 port 2 coupler to front panel port 2 CPLR ARM
  - W32 (N5247-20049) Port 1 CPLR THRU to A33 port 1 coupler
  - W44 (N5247-20050) Port 2 CPLR THRU to A36 port 2 coupler
  - W70 (N5247-20100) A25 HMA26.5 to A27 mixer brick
  - W151 (N5247-20056) A29 port 1 reference coupler to A37 reference mixer switch
  - W154 (N5247-20057) A32 port 2 reference coupler to front panel REF 2 SOURCE OUT
4. Remove and discard the following gray flexible cables:
  - W72 (N5242-60025) A27 mixer brick (R1) to A24 IF multiplexer (P601)
  - W73 (N5242-60026) A27 mixer brick (R2) to A24 IF multiplexer (P801)
  - W99 (N5247-60023) A16 SPAM board (J2) to A24 IF multiplexer (P603)
  - W100 (N5247-60024) A16 SPAM board (J5) to A24 IF multiplexer (P203)
5. Leave any remaining gray flexible cables, the wire harnesses, and the ribbon cables connected where possible. Any that are removed should be labeled for reconnection later.

## Step 9. Remove the A60 70 GHz Doubler Assembly From the Test Set Deck

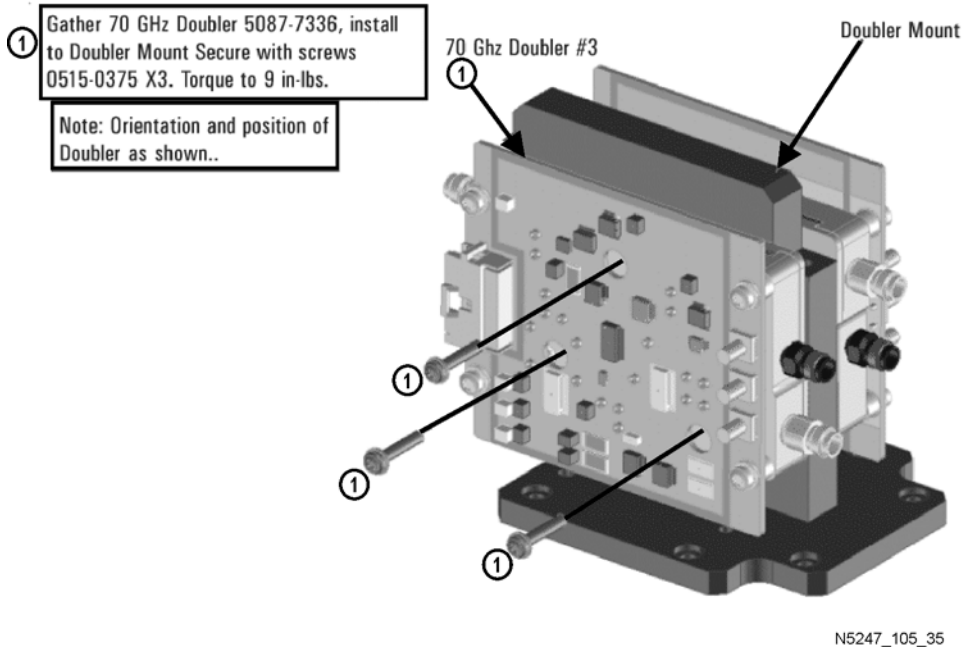
Remove the 70 GHz doubler 1 assembly from the test set deck. For instructions, click the Chapter 7 bookmark, "Removing and Replacing the A60-A63 70 GHz Doublers" in the PDF Service Guide<sup>1</sup>. Keep all parts for reinstallation later.

## Step 10. Assemble the A61 70 GHz Doubler on the Doubler Mount

1. Follow the instruction in [Figure 2](#) to install the A61 70 GHz doubler 3 on the doubler mount. New parts are listed in [Table 1 on page 7](#) of this document.

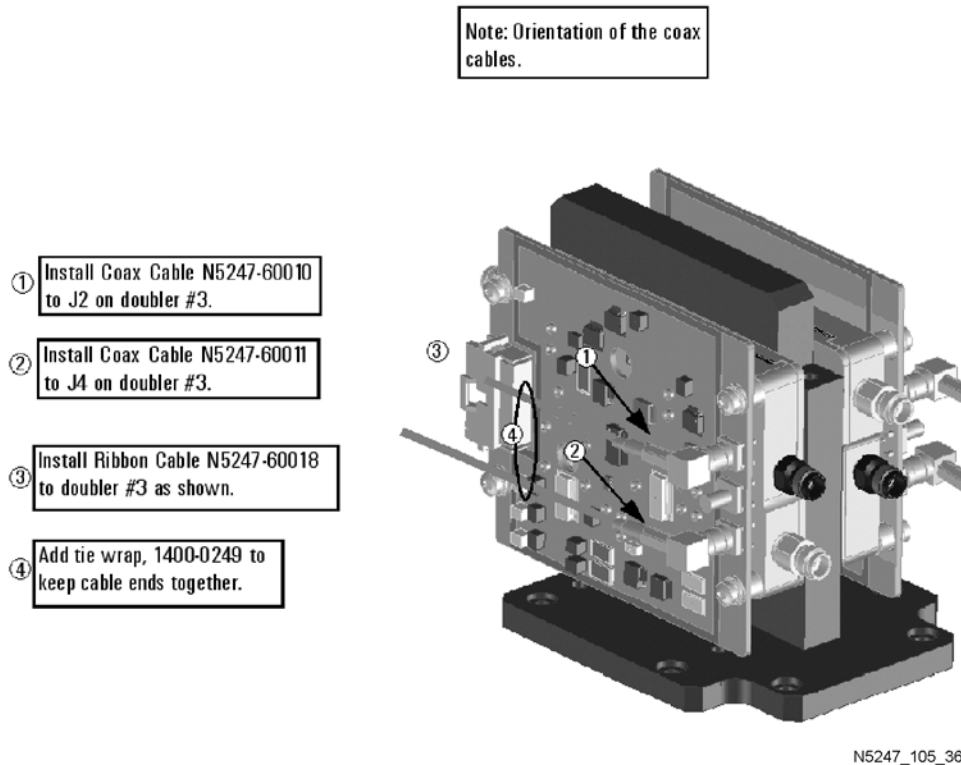


**Figure 2 Installing A61 Doubler 3 on the Doubler Mount**



2. Connect the cables to the A61 70 GHz doubler 3 in the order shown in **Figure 3**. The other ends of the cables will be connected later.

**Figure 3 A61 70 GHz Doubler Assembly**



### **Step 11. Reinstall the A60/A61 70 GHz Doubler Assembly**

Reinstall the A60 70 GHz doubler 1 cables, and then reinstall the A60/A61 70 GHz doubler assembly on the test set deck, reusing the existing screws. For instructions, click the Chapter 7 bookmark, "Removing and Replacing the A60-A63 70 GHz Doublers" in the PDF Service Guide<sup>1</sup>.

### **Step 12. Remove the A63 70 GHz Doubler Assembly From the Test Set Deck**

Remove the A63 70 GHz doubler 2 assembly from the test set deck. For instructions, click the Chapter 7 bookmark, "Removing and Replacing the A60-A63 70 GHz Doublers" in the PDF Service Guide<sup>1</sup>. Keep all parts for reinstallation later.

---

1. See ["Downloading the Online PNA Service Guide"](#) on page 5.

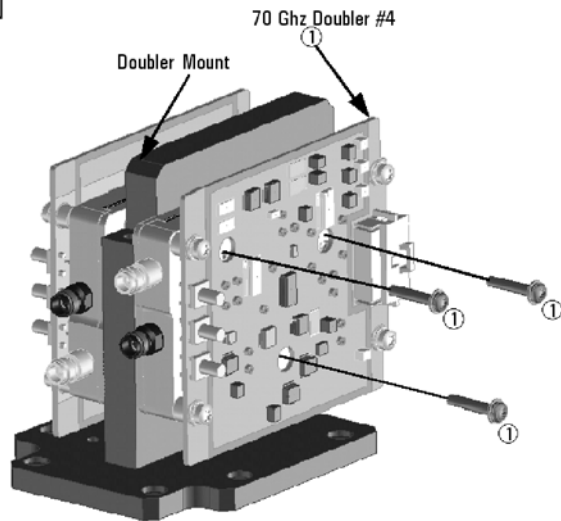
### Step 13. Assemble the A62 70 GHz Doubler on the Doubler Mount

1. Follow the instruction in **Figure 4** to install the A62 70 GHz doubler 4 on the doubler mount. New parts are listed in **Table 1** on **page 7** of this document.

**Figure 4**      **Installing A62 Doubler 4 on the Doubler Mount**

① Gather 70 GHz Doubler 5087-7336, install to Doubler Mount Secure with screws 0515-0375 X3. Torque to 9 in-lbs.

Note: Orientation and position of Doubler as shown..



N5247\_105\_37

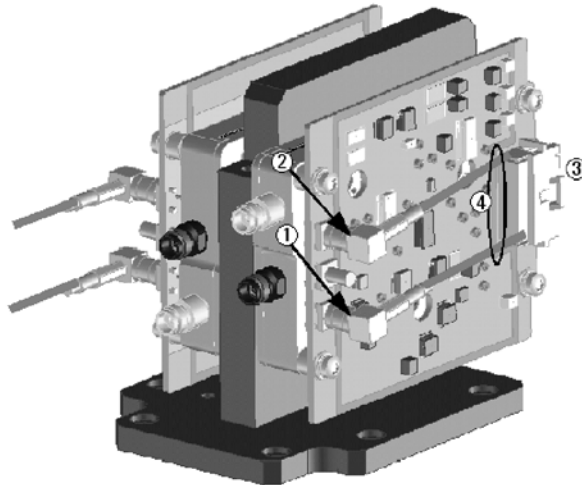
2. Connect the cables to the A62 70 GHz doubler in the order shown in **Figure 5**. The other ends of the cables will be connected later.

**Figure 5 A62 70 GHz Doubler Assembly**



Note: Orientation of the coax cables.

- ① Install Coax Cable N5247-60012 to J2 on doubler #4.
- ② Install Coax Cable N5247-60013 to J4 on doubler #4.
- ③ Install Ribbon Cable N5247-60018 to doubler #4 as shown.
- ④ Add tie wrap, 1400-0249 to keep cable ends together.



N5247\_105\_38

### Step 14. Reinstall the A62/A63 70 GHz Doubler Assembly

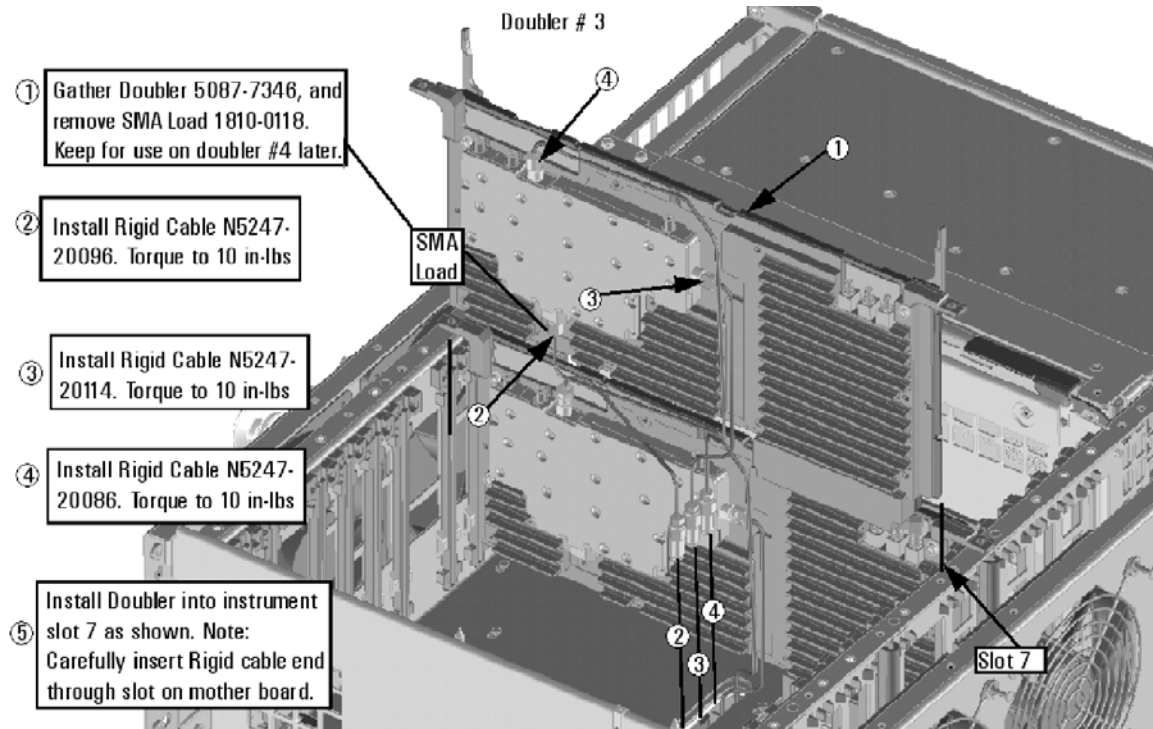
Reinstall the A63 70 GHz doubler 2 cables, and then reinstall the A62/A63 70 GHz doubler assembly on the test set deck, reusing the existing screws. For instructions, click the Chapter 7 bookmark, "Removing and Replacing the A60-A63 70 GHz Doublers" in the PDF Service Guide<sup>1</sup>.

1. See "Downloading the Online PNA Service Guide" on page 5.

## Step 15. Assemble and Install the A12 40 GHz Doubler Assembly

Follow the five instructions shown in [Figure 6](#).

**Figure 6** A12 40 GHz Doubler 3 Assembly Installation

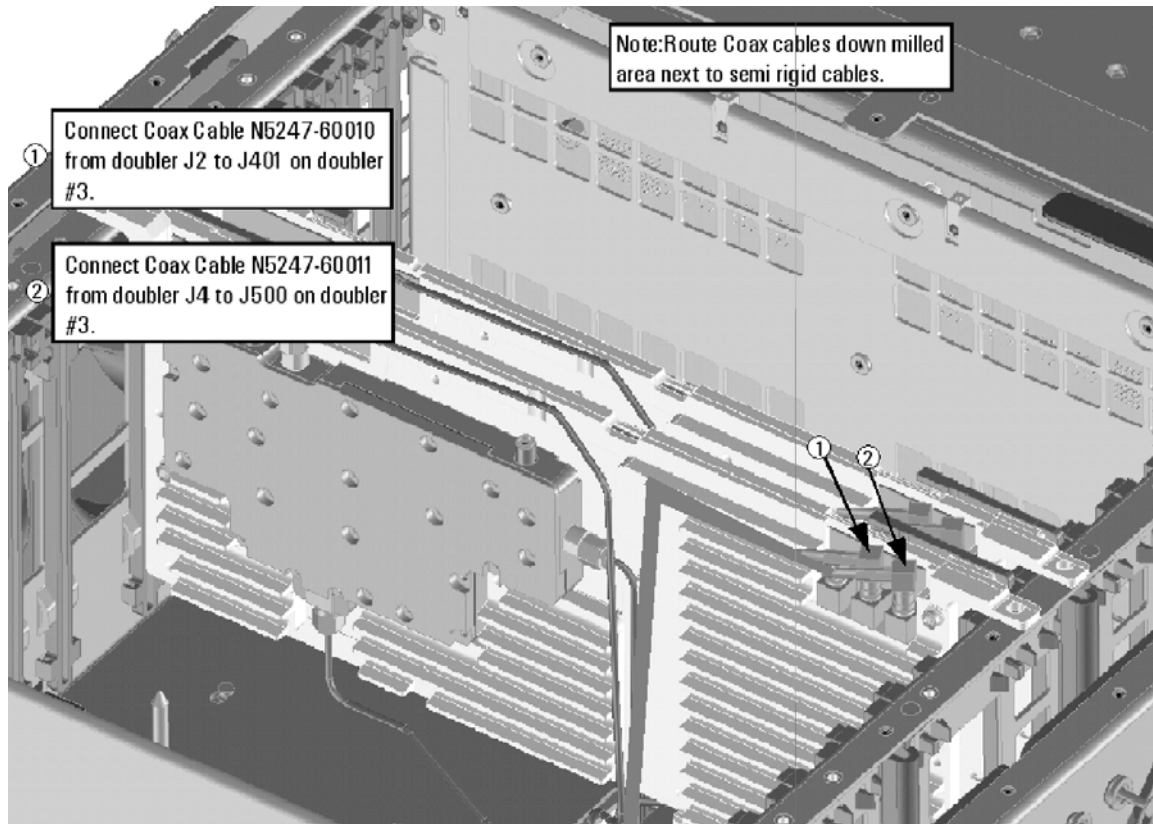


N5247\_105\_41

## Step 16. Install the A12 40 GHz Doubler Cables

Follow the three instructions shown in [Figure 7](#).

**Figure 7** A12 40 GHz Doubler 3 Assembly Cable Installation

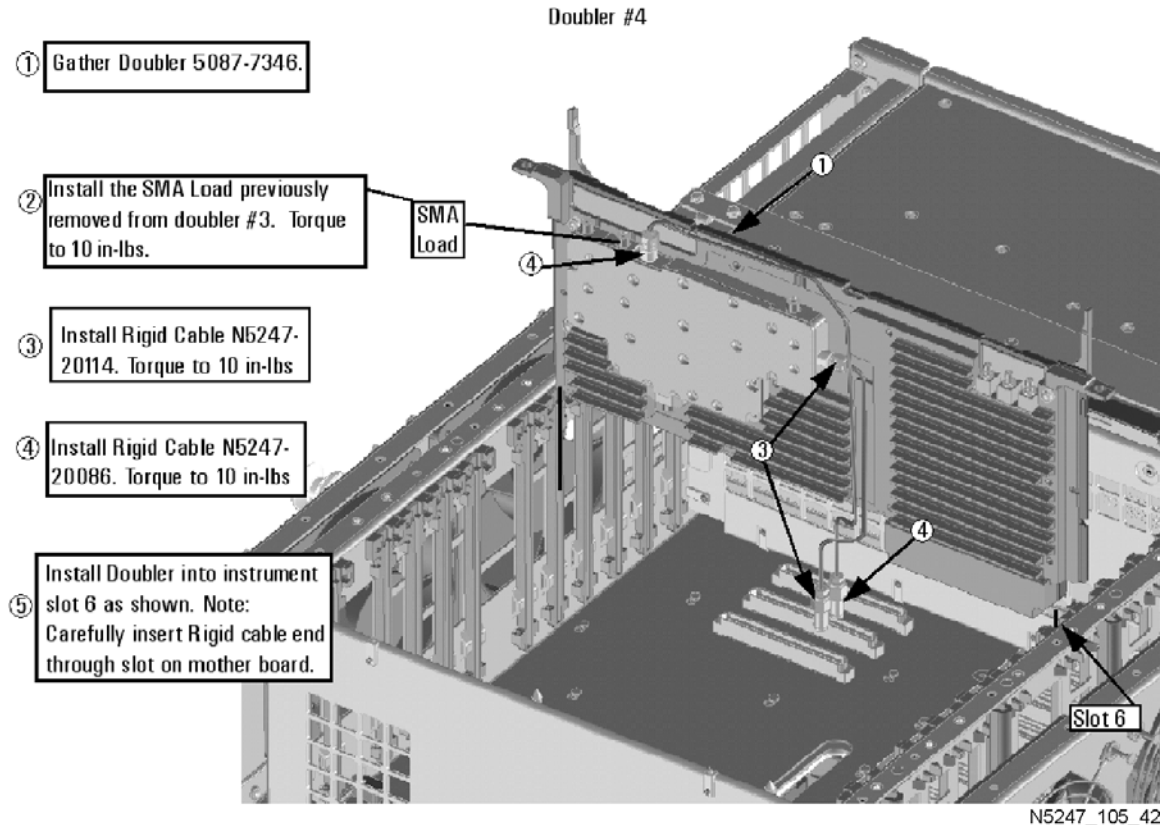


N5247\_105\_44

## Step 17. Assemble and Install the A13 40 GHz Doubler Assembly

Follow the five instructions shown in [Figure 8](#).

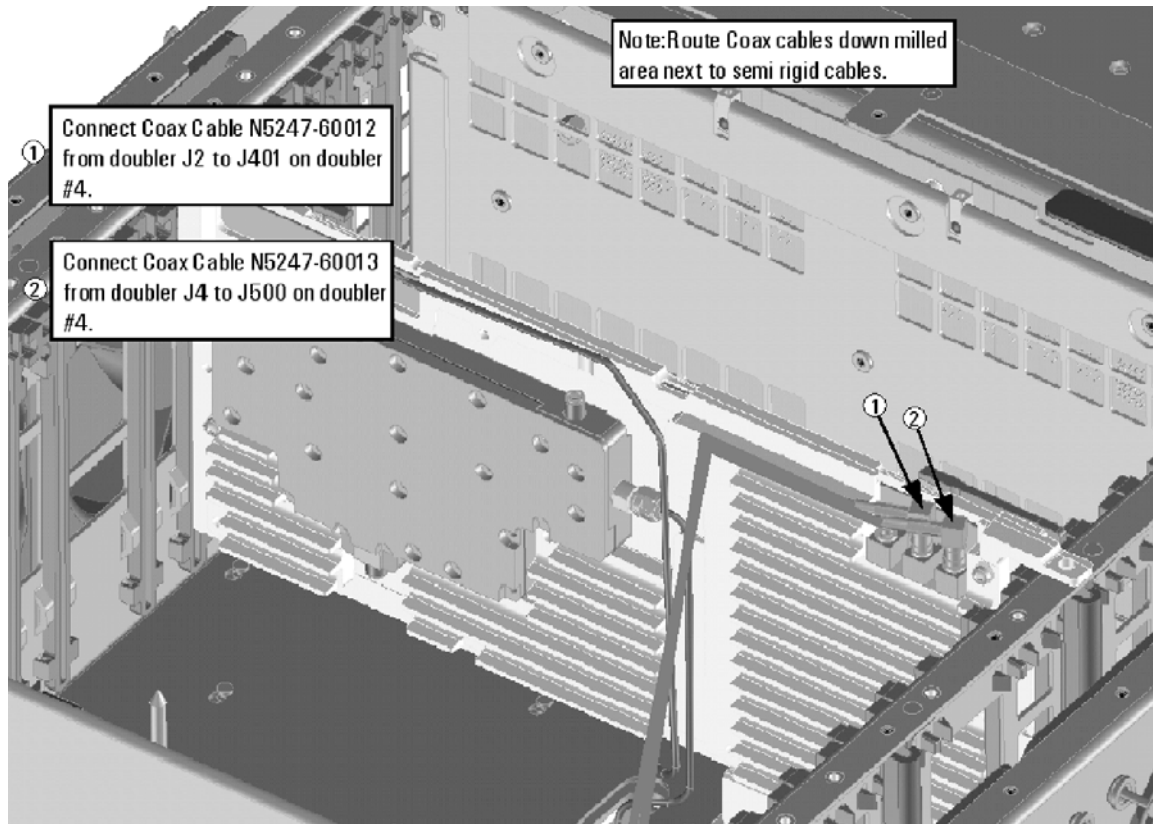
**Figure 8** A13 40 GHz Doubler 4 Installation



## Step 18. Install the A13 40 GHz Doubler Cables

Follow the three instructions shown in [Figure 9](#).

**Figure 9** A13 40 GHz Doubler 4 Cable Installation



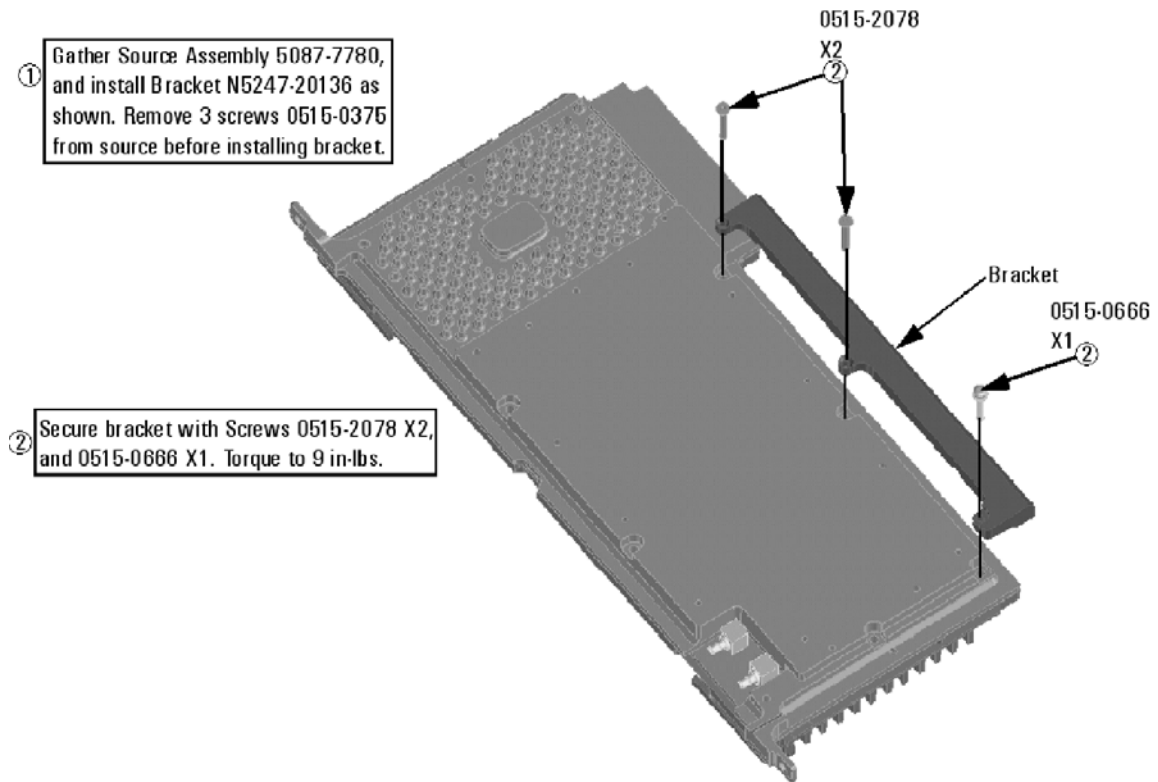
N5247\_105\_43



## Step 19. Install Bracket to A10 26.5 GHz Source 2 Assembly

Follow the two instructions shown in [Figure 10](#).

**Figure 10** A10 Source 2 Assembly Bracket Installation

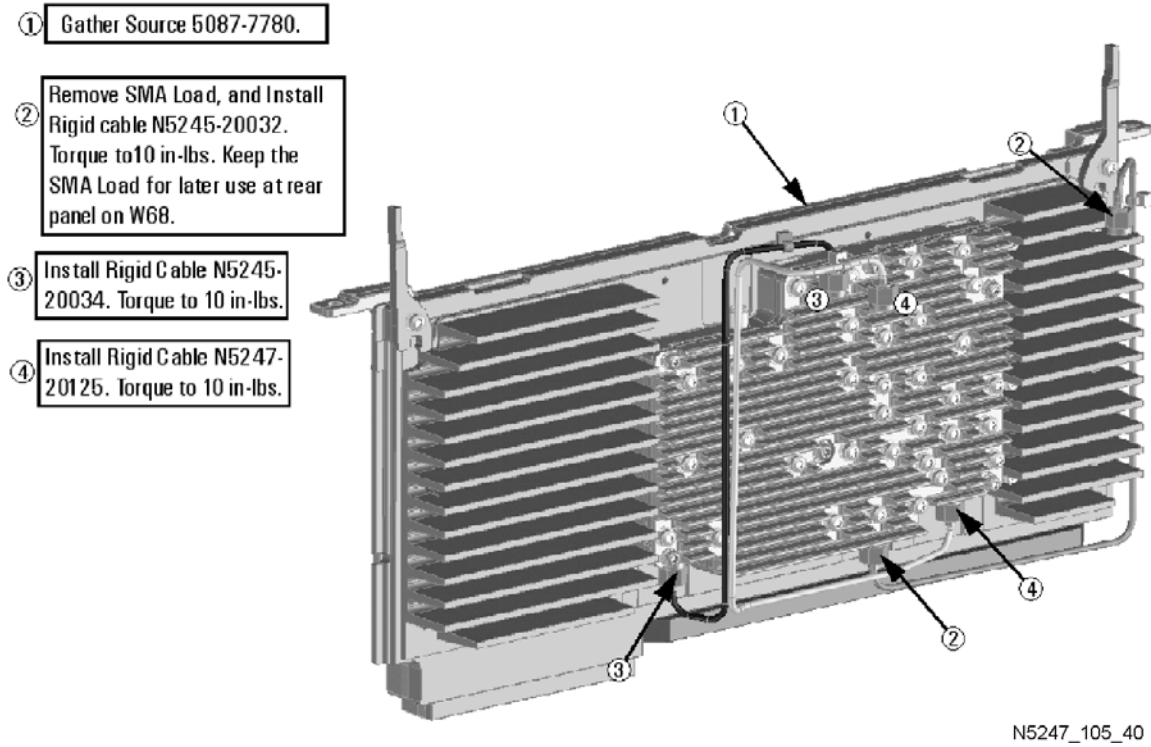


N5247\_105\_39

## Step 20. Assemble the A10 26.5 GHz Source 2 Assembly

Follow the four instructions shown in [Figure 11](#).

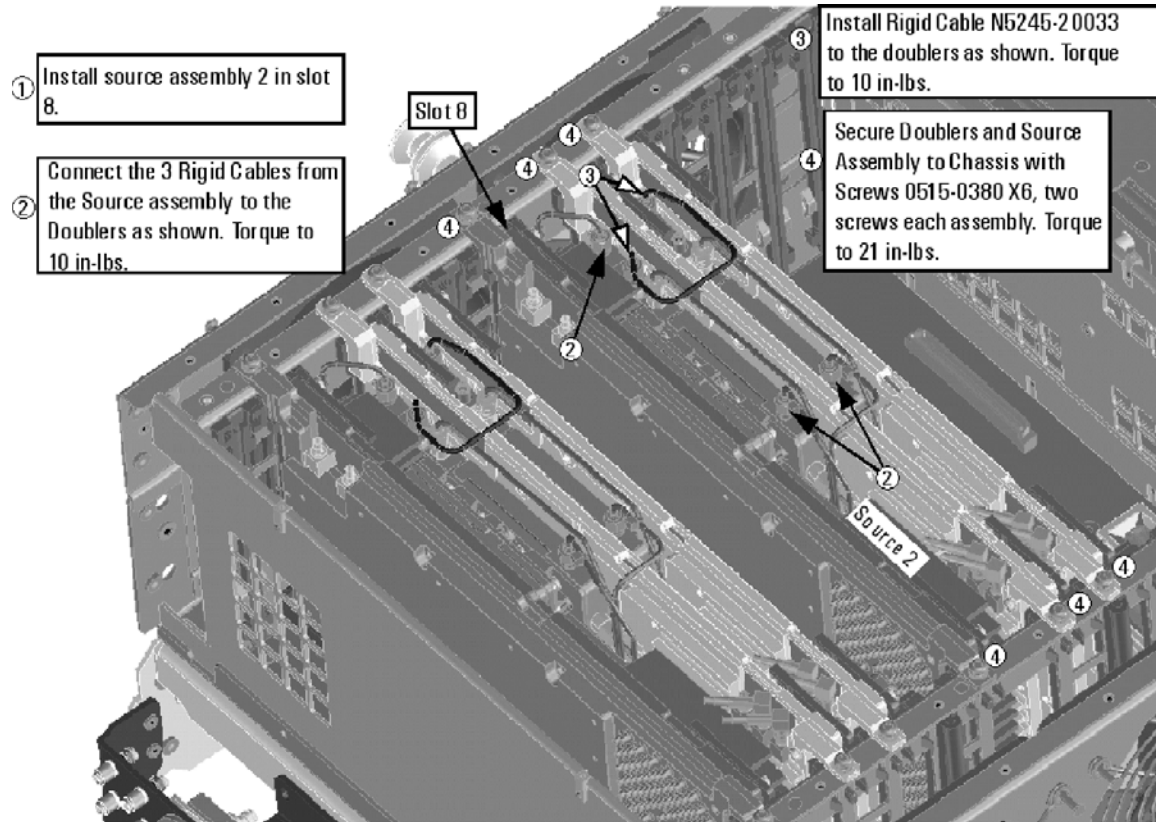
**Figure 11** A10 Source 2 Assembly



## Step 21. Install the A10 26.5 GHz Source 2 Assembly and Cables

Follow the four instructions shown in [Figure 12](#).

**Figure 12** A10 Source 2 Assembly Installation



N5247\_105\_45

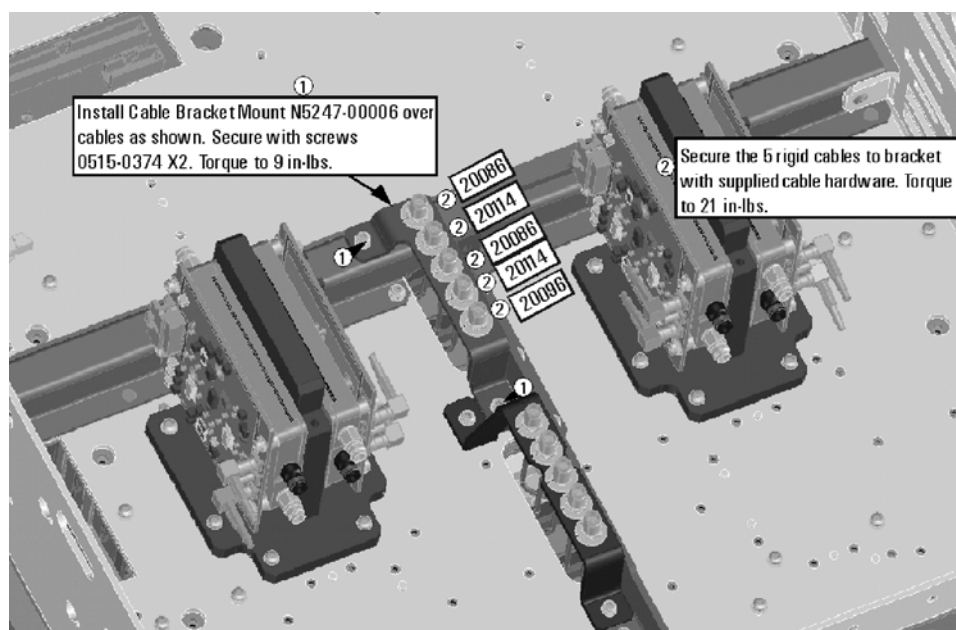
## Step 22. Install the A17 13.5 GHz (Source 2) Synthesizer Board and Cables

1. Install new gray cable W87 (N5242-60030) to connector J5 of the new A17 (source 2) synthesizer board (N5240-60074). The loose end of the cable will be connected on the A14 frequency reference board (J7) after the A17 board has been installed in the analyzer.
2. Install the A17 board into slot 2 in the motherboard. Secure the board into the chassis using two screws (0515-0380). To see an image showing the location of the A17 board in the motherboard, click the Chapter 6 bookmark "Top Assemblies, All Options" in the PDF Service Guide<sup>1</sup>.
3. Connect cable W2 (N5245-20100) between the A10 source 2 board and the A17 (source 2) synthesizer board, positioning the cable in the wire looms. Tighten the cable connectors to 10 in-lbs using a 5/16-in torque wrench.
4. Connect the loose end of new gray flex cable W87 (N5242-60030) on the A14 frequency reference board (J7). (The other end of this cable was previously connected to J5 of the source 2 synthesizer board.)

## Step 23. Install the Cable Bracket Mount

1. Follow the two instructions shown in [Figure 13](#). New parts are listed in [Table 1 on page 7](#) of this document.

**Figure 13** Cable Bracket Mount Installation



N5247\_105\_07

## Step 24. Remove the A27 Mixer Brick Assembly

Remove the A27 mixer brick assembly from the PNA. For instructions, click the Chapter 7 bookmark, "Removing and Replacing the A27 and A28 Mixer Bricks" in the PDF Service Guide<sup>1</sup>.

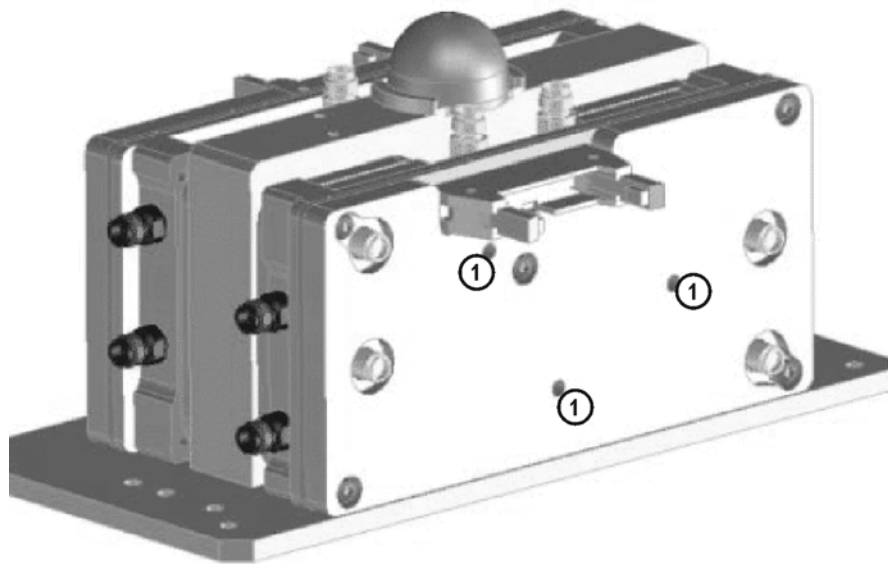
1. See ["Downloading the Online PNA Service Guide" on page 5](#).

## Step 25. Assemble the A28 Mixer Brick Assembly

1. Follow the instruction shown in [Figure 14](#). New parts are listed in [Table 1 on page 7](#) of this document.

**Figure 14**    **A28 Mixer Brick Assembly**

① Install A28 mixer brick 5087-7337 to mounting block using screws 0515-1038. Torque to 9 in-lbs.



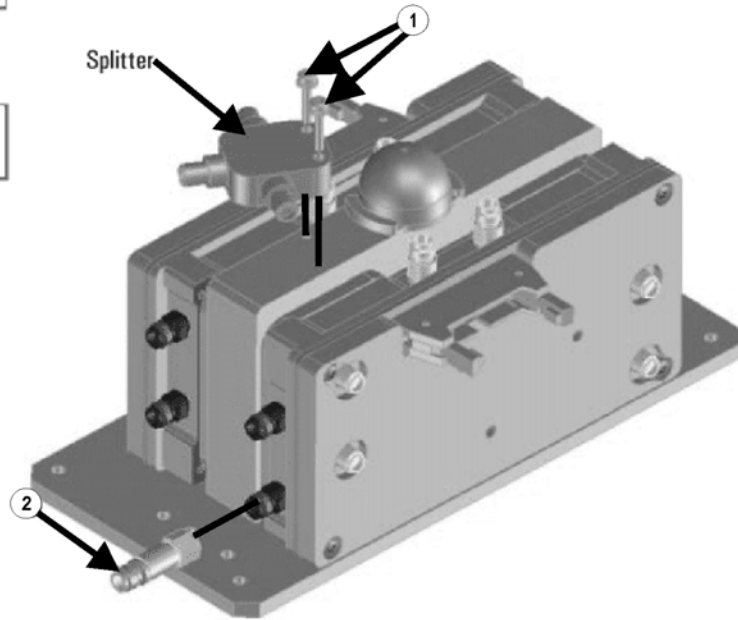
N5247\_105\_17

2. Follow the two instructions shown in [Figure 15](#).

**Figure 15 A26 Splitter and A69 3 dB Pad Installation**

① Install splitter 5067-4086 (label facing up), secure with screws 0515-2007 X2. Leave loose for now.

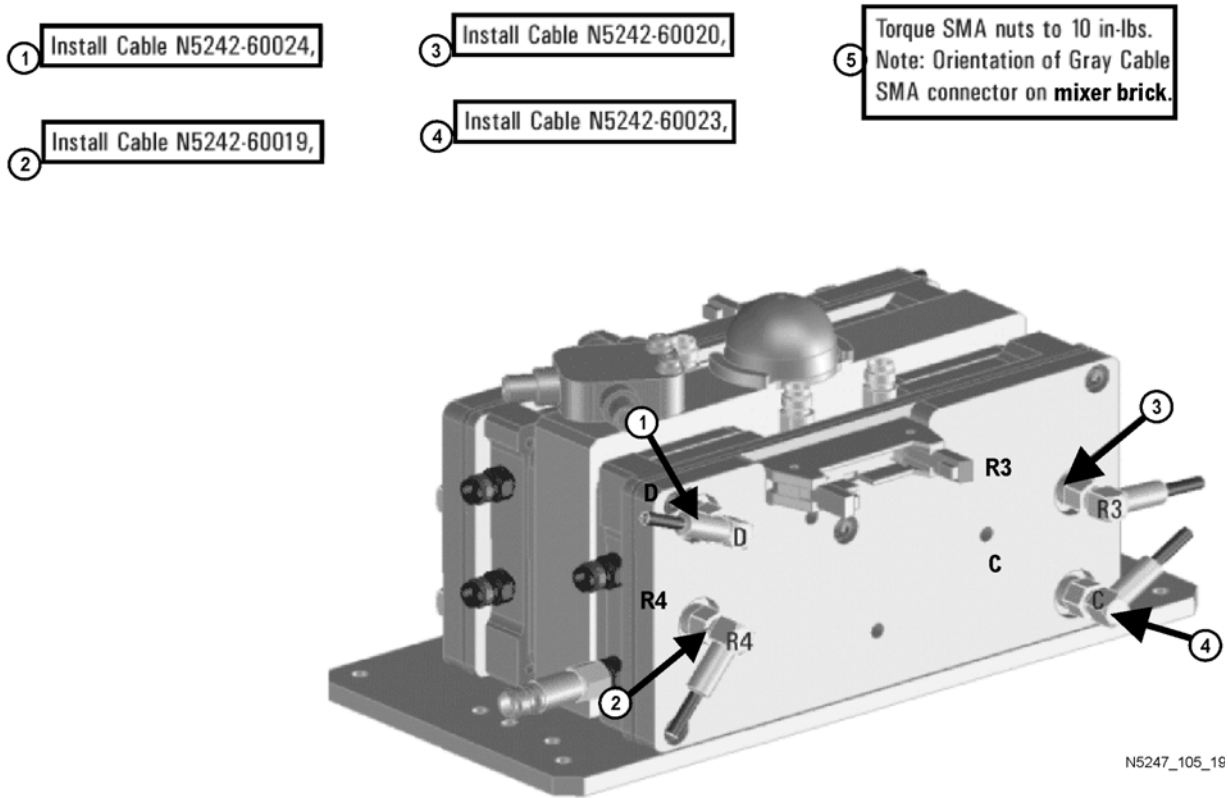
② Install 3dB pad 08490-60037 X1 only on R4 connector of A28 mixer brick. Torque to 10 in-lbs.



N5247\_105\_18

3. Connect the gray flexible cables to the A28 mixer in the order shown in [Figure 16](#). The other ends of the cables will be connected when the IF board is reinstalled later.

**Figure 16 A28 Mixer Brick Cable Installation**



### Step 26. Install the A27/A28 Mixer Brick Assemblies

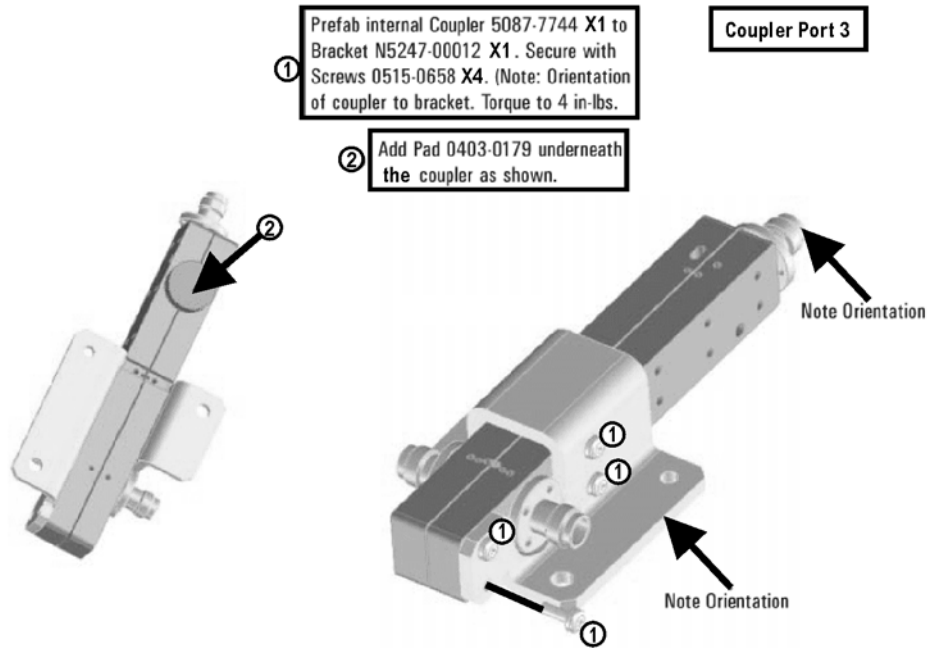
Reinstall the A27 mixer brick cables, and then install the A27/A28 mixer brick assembly, reusing the 10 existing screws. For instructions, click the Chapter 7 bookmark, “Removing and Replacing the A27 and A28 Mixer Bricks” in the PDF Service Guide<sup>1</sup>. New parts are listed in [Table 1 on page 7](#) of this document.

### Step 27. Assemble the A30 and A31 Reference Coupler Assemblies

Follow the instructions shown in [Figure 17](#) and [Figure 18](#). New parts are listed in [Table 1 on page 7](#) of this document.

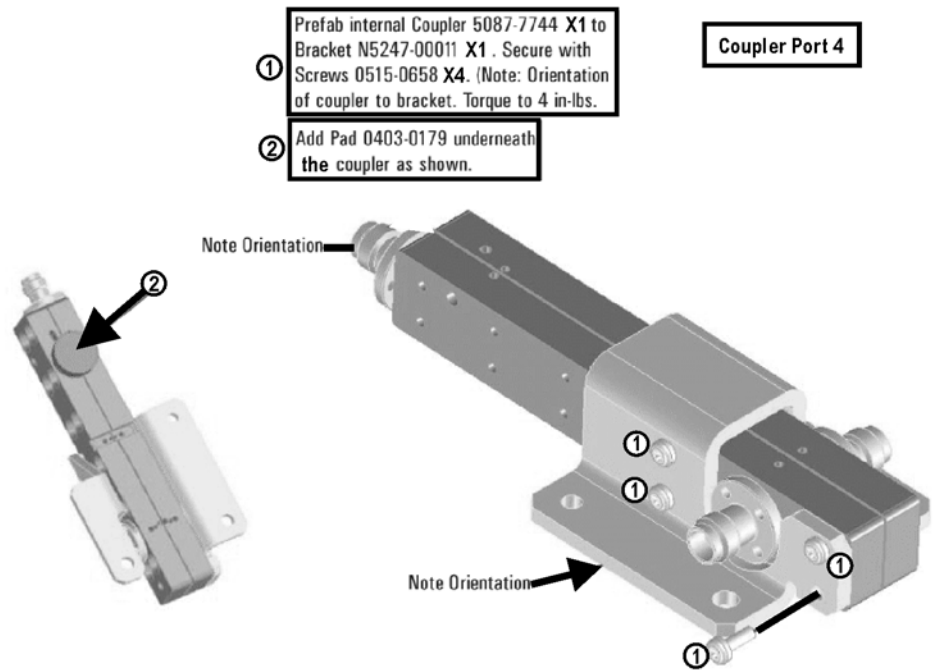
1. See [“Downloading the Online PNA Service Guide” on page 5](#).

**Figure 17 A30 Reference Coupler Assembly**



N5247\_105\_20

**Figure 18 A31 Reference Coupler Assembly**



N5247\_105\_21

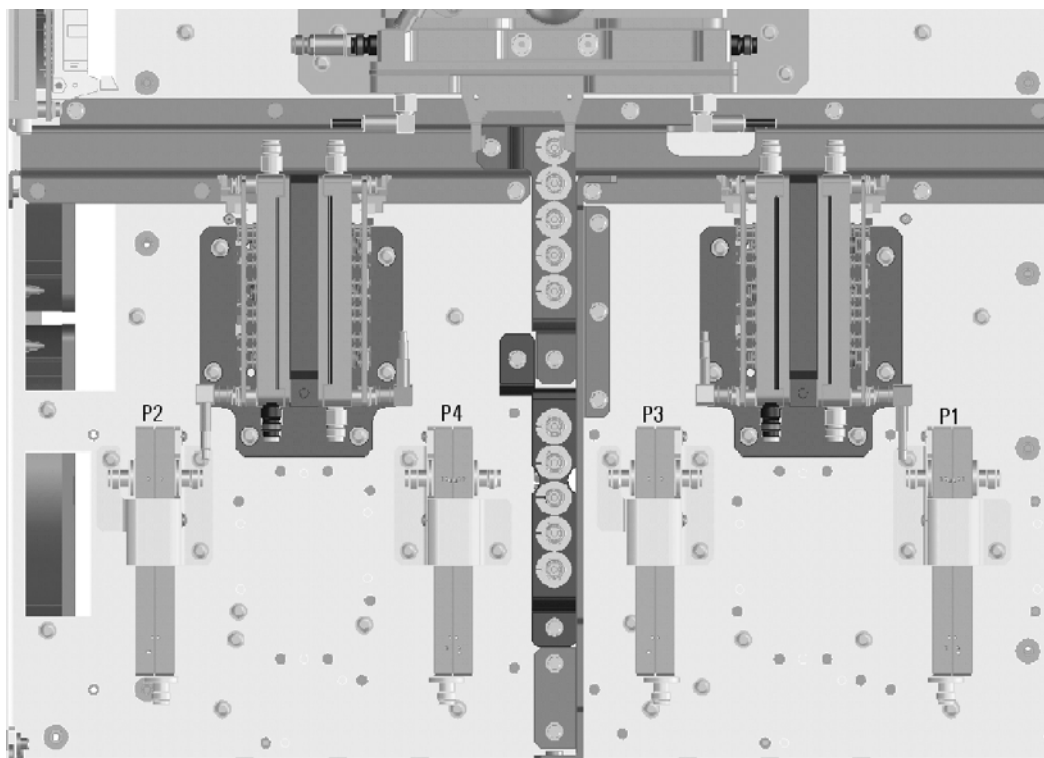


## Step 28. Install the A30 and A31 Reference Coupler Assemblies

Install the A30 and A31 reference coupler assemblies using three 0515-0372 screws to secure each bracket. For instructions, click the Chapter 7 bookmark, "Removing and Replacing the A29-A32 Reference Couplers and Reference Coupler Mounting Brackets" in the PDF Service Guide<sup>1</sup>. New parts are listed in [Table 1 on page 7](#) of this document.

Refer to [Figure 19](#) for the location of the reference coupler assemblies.

**Figure 19** Location of Reference Coupler Assemblies



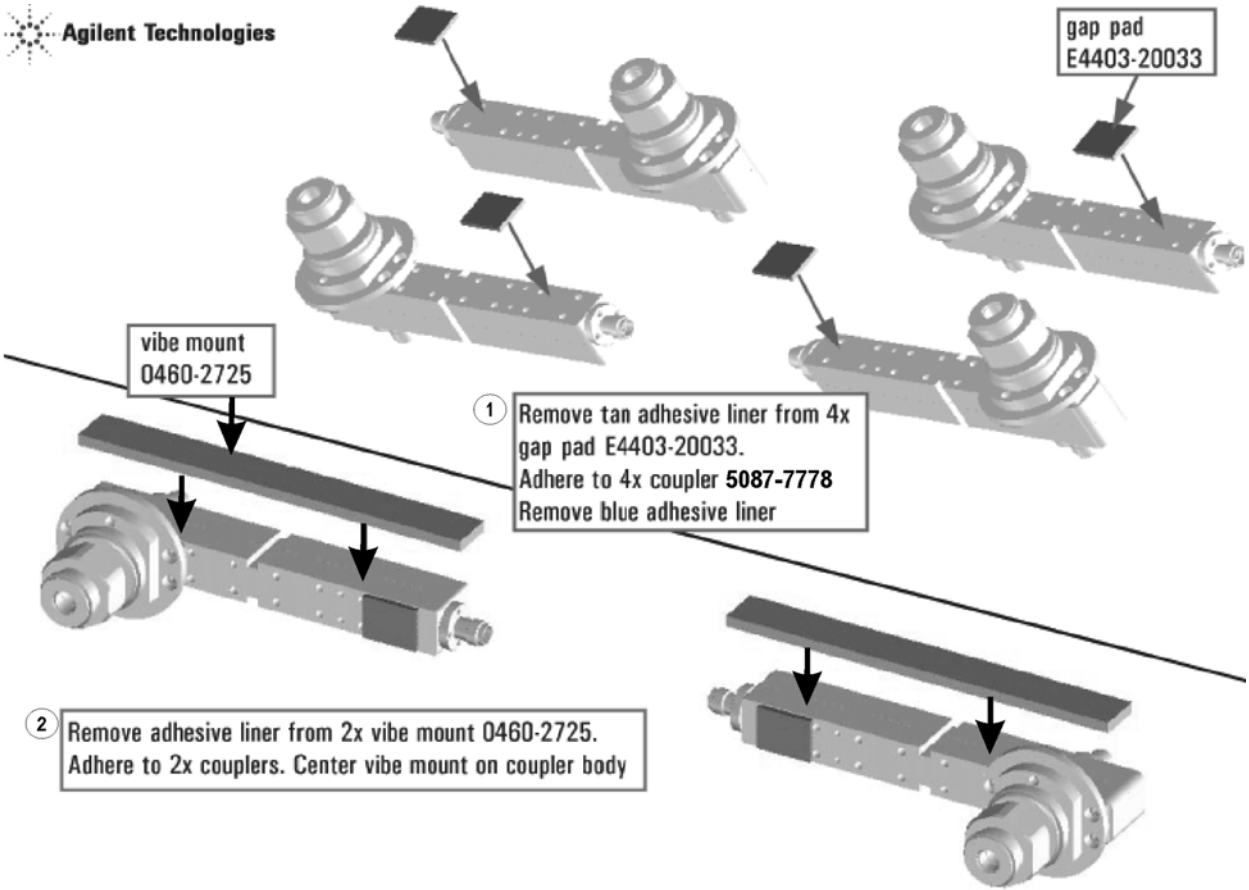
N5247\_105\_24

## Step 29. Assemble the A33 - A36 Test Port Coupler Assemblies

1. Remove the A33 test port 1 coupler and A36 test port 2 coupler from the PNA. For instructions, click the Chapter 7 bookmark, "Removing and Replacing the A33 - A36 Test Port Couplers" in the PDF Service Guide<sup>1</sup>.
2. Using pliers, remove the adhesive bumper on the A33 test port 1 coupler and on the A36 test port 2 coupler.
3. Follow the two instructions shown in [Figure 20](#). New parts are listed in [Table 1 on page 7](#) of this document.

1. See ["Downloading the Online PNA Service Guide" on page 5](#).

Figure 20 A33 - A36 Test Port Coupler Assembly



N5247\_105\_11

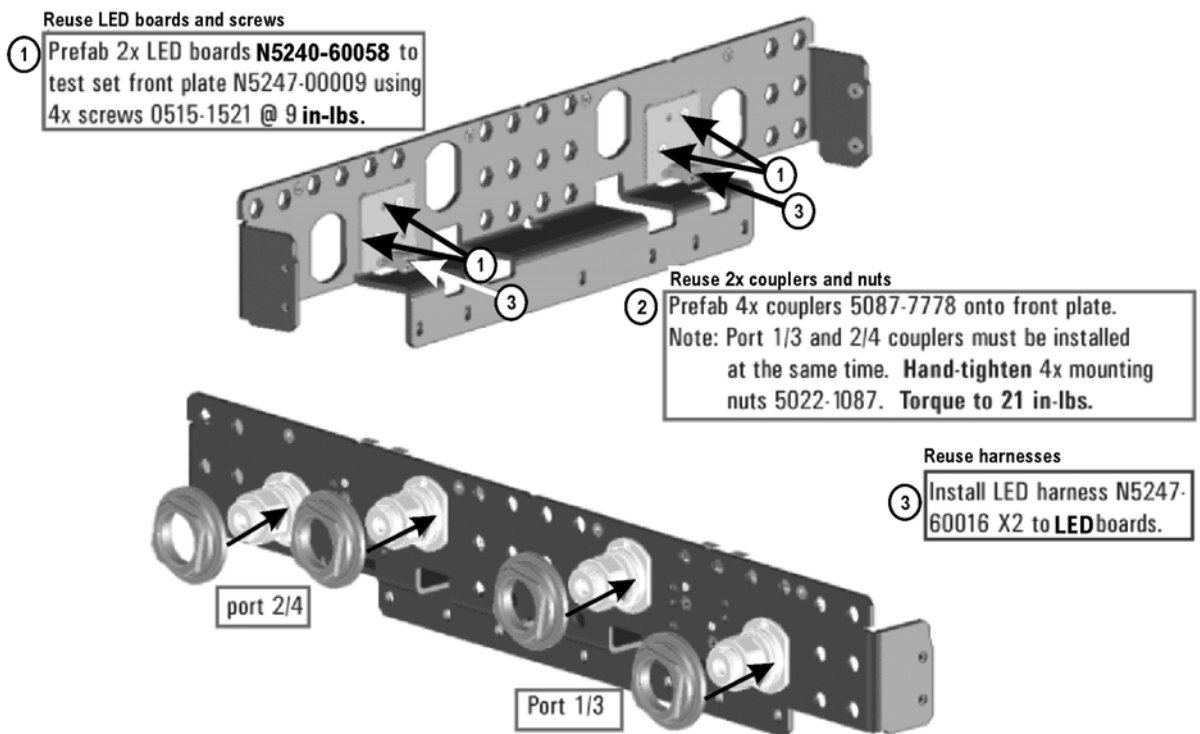
### Step 30. Remove and Disassemble the 2-Port Test Set Front Plate

1. Remove two screws from each LED board and remove the boards from the 2-port test set front plate of the PNA. Keep the screws for reinstallation later.
2. Remove the 2-port test set front plate from the test set deck. Keep the screws to reuse later.
3. Remove the 12 bulkhead connectors, nuts and washers from the 2-port front plate to reuse later.

### Step 31. Install the LED Boards, Bulkhead Connectors, and Test Port Coupler Assemblies to the 4-Port Test Set Front Plate

1. Follow the three instructions shown in [Figure 21](#).

Figure 21 LED Board Assemblies and Test Port Coupler Assemblies Installation



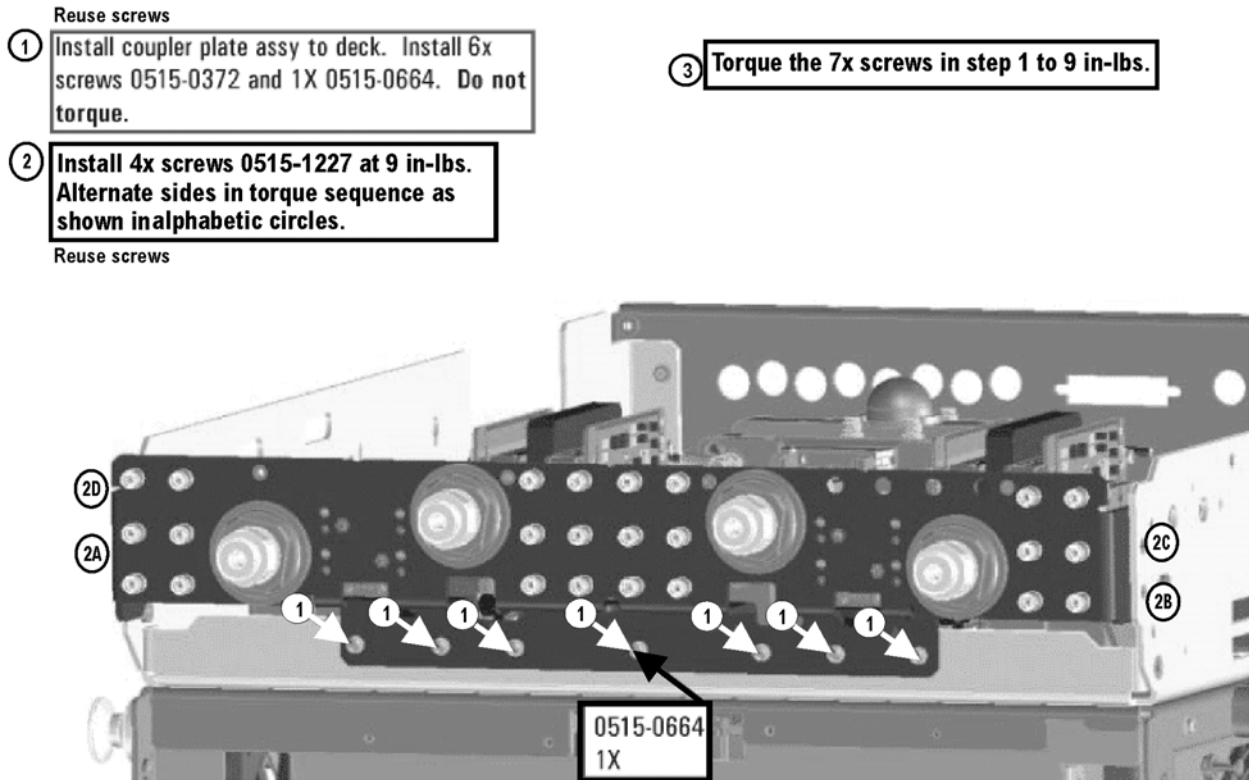
N5247\_105\_12

2. Reinstall the 12 bulkhead connectors, nuts and washers taken from the 2-port front plate into the 4-port front plate. Torque to 21 in-lbs.
3. Install 12 new bulkhead connectors (5065-4673), nuts (1250-3516) and washers (1250-3310) into the 4-port front plate. Torque to 21 in-lbs.

## Step 32. Install the 4-Port Coupler Plate Assembly to the Deck

Follow the three instructions shown in [Figure 22](#).

**Figure 22** Coupler Plate Assembly Installation



N5247\_106\_1:

## Step 33. Install Some Bottom-Side (Test Set) Cables

---

**CAUTION** Use a 5/16-in torque wrench set to 10 in-lbs on all cable connections except the front and rear panel cable connectors. Torque these connections to 21 in-lb.

---

---

**CAUTION** Be careful not to damage the center pins of the semirigid cables. Some flexing of the cables may be necessary but do not over-bend them.

---

### Flexible Cables Required for Upgrading to an Option 400 PNA

Install the following gray flexible cables in the order listed. 70 GHz cables were connected to the 70 GHz doublers earlier in this procedure, but the other ends of these cables still require a connection. To see images showing the location of these cables, click either of the Chapter 6 bookmarks "Bottom RF Cables, 4-Port, Option 400" in the PDF Service Guide<sup>1</sup>. New parts are listed in [Table 1 on page 7](#).

- W91 (reuse) (N5247-60006) A60 port 1 70 GHz doubler (J2) to A7 40 GHz doubler (J401)

- W92 (reuse) (N5247-60007) A60 port 1 70 GHz doubler (J4) to A7 40 GHz doubler (J500)
- W97 (reuse) (N5247-60008) A63 port 2 70 GHz doubler (J2) to A8 40 GHz doubler (J401)
- W98 (reuse) (N5247-60009) A63 port 2 70 GHz doubler (J4) to A8 40 GHz doubler (J500)

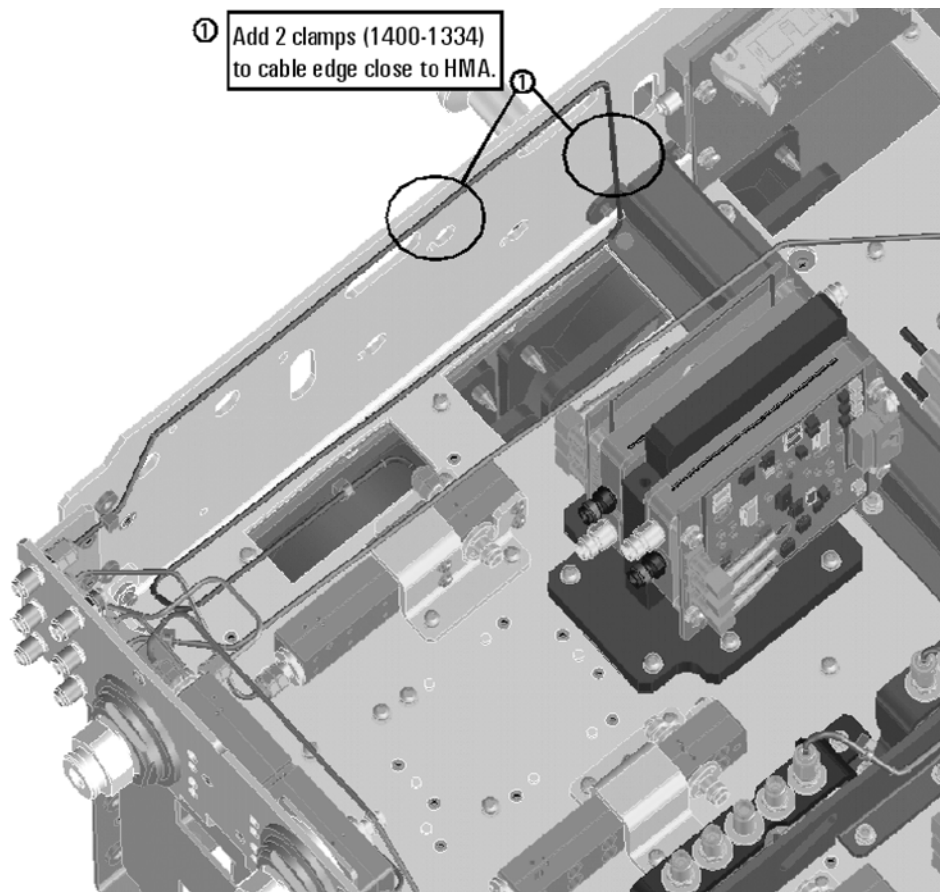
### **Semirigid Cables Required for Upgrading to an Option 400 PNA**

To see images showing the location of these cables, click the Chapter 6 bookmark “Bottom RF Cables, 4-Port, Option 400” in the PDF Service Guide<sup>1</sup>. New parts are listed in [Table 1 on page 7](#).

- W69 (reuse) (N5247-20112) A27 mixer brick to rear-panel EXT TSET DRIVE LO OUT (J5)
- W68 (N5247-20088) rear panel port RF2 OUT (J12) to W67
  - \* Install SMA load previously removed from A10 26.5 GHz source board onto rear panel port RF2 OUT (J12).
- W50 (reuse) (N5247-20054) front-panel port 2 RCVR B IN to A27 mixer brick (B)
- W44 (N5247-20018) Port 2 CPLR THRU to A36 port 2 coupler
- W46 (N5247-20019) A36 port 2 coupler to port 2 CPLR ARM
- W43 (reuse) (N5247-20036) A32 port 2 ref coupler to front-panel port 2 SOURCE OUT
- W40 (N5247-20017) Port 4 CPLR THRU to A35 port 4 coupler
- W45 (N5247-20076) A32 port 2 ref coupler to front-panel REF 2 SOURCE OUT
  - \* As shown in [Figure 23](#), install two clamps (part number 1400-1334) to secure W45.

1. See [“Downloading the Online PNA Service Guide” on page 5](#).

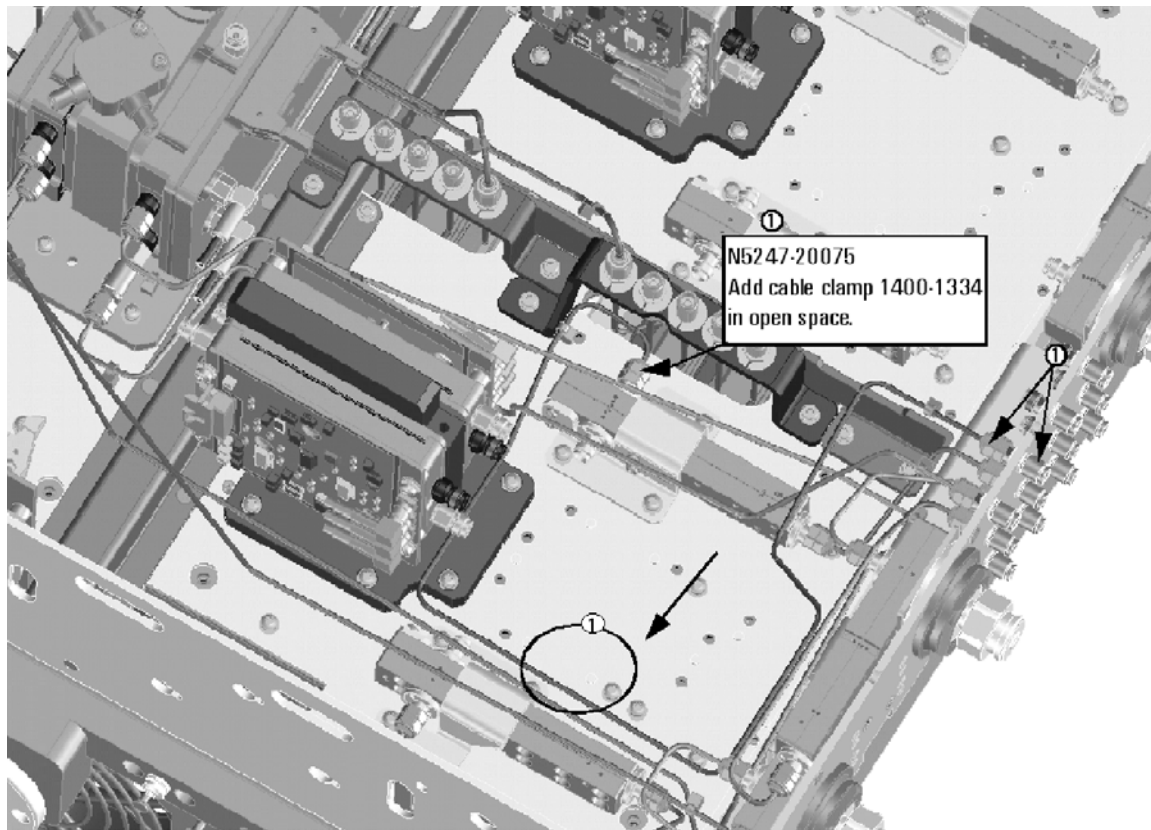
**Figure 23**    **Location of Two Cable Clamps to Secure W45**



N5247\_105\_14

- W56 (reuse) (N5247-20055) REF 2 RCVR R2 IN to A27 mixer brick (R2)
  - W55 (N5247-20067) A28 mixer brick (R4) to REF 4 RCVR R4 IN
  - W49 (N5247-20073) Port 4 RCVR D IN to A28 mixer brick (D)
  - W42 (N5247-20026) A35 port 4 coupler to port 4 CPLR ARM
  - W39 (N5247-20035) A31 port 4 ref coupler to front-panel port 4 SOURCE OUT
  - W41 (N5247-20075) A31 port 4 ref coupler to front-panel REF 4 SOURCE OUT
- \* As shown in **Figure 24**, install clamp (part number 1400-1334) to secure W41.

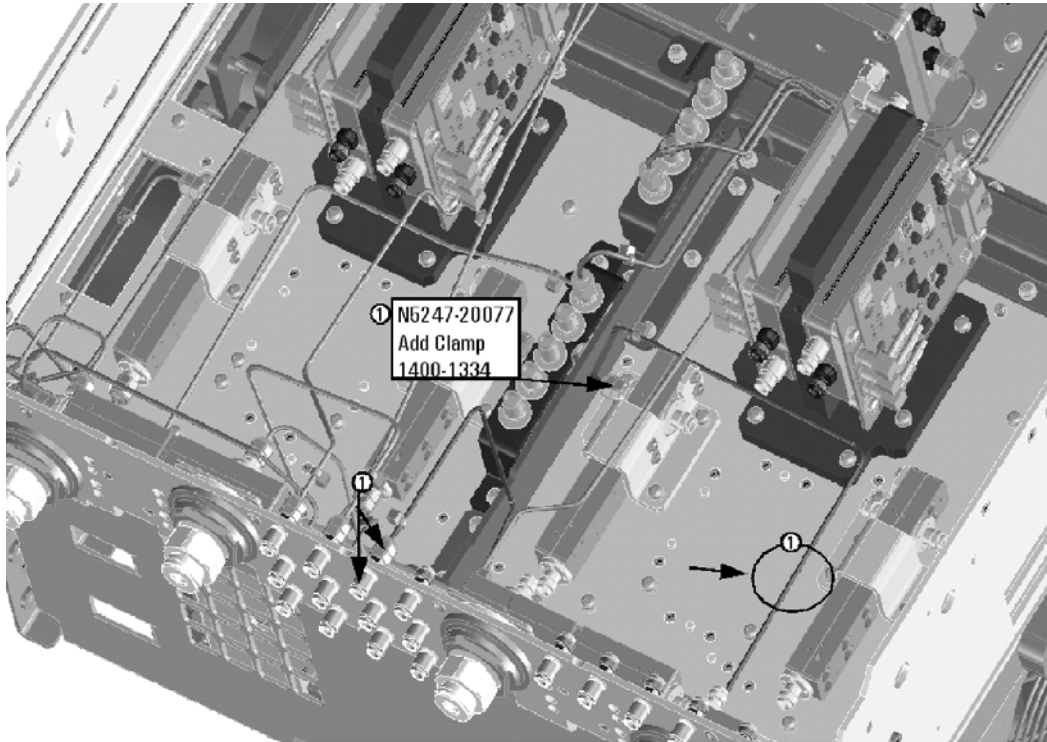
**Figure 24** Location of Cable Clamp to Secure W41



N5247\_105\_15

- W37 (N5247-20077) A30 port 3 ref coupler to front-panel REF 3 SOURCE OUT  
\* As shown in [Figure 25](#), install clamp part number 1400-1334 to secure W37.

**Figure 25**      **Location of W37 Cable Securing Clamp**



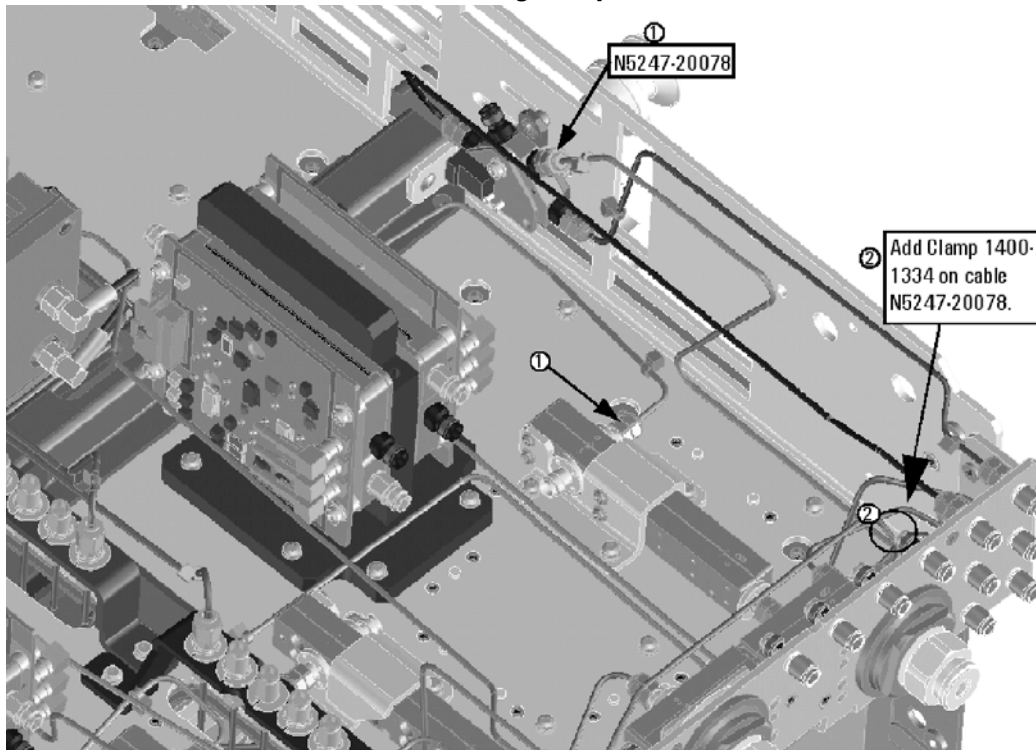
N5247\_105\_16

- W48 (N5247-20063) Port 3 RCVR C IN to A28 mixer brick (C)
- W38 (N5247-20007) Port 3 CPLR ARM to A34 port 3 coupler
- W35 (N5247-20023) A30 port 3 ref coupler to front-panel port 3 SOURCE OUT
- W32 (N5247-20016) Port 1 CPLR THRU to A33 port 1 coupler
- W36 (N5247-20006) Port 3 CPLR THRU to A34 port 3 coupler
- W51 (reuse) (N5247-20011) Front-panel REF 1 SOURCE OUT to A37 ref mixer switch
- W33 (N5247-20078) A29 port 1 reference coupler to A37 reference mixer switch

\* As shown in **Figure 26**, install clamp part number 1400-1334 to secure W33.



**Figure 26**      **Location of W33 Cable Securing Clamp**

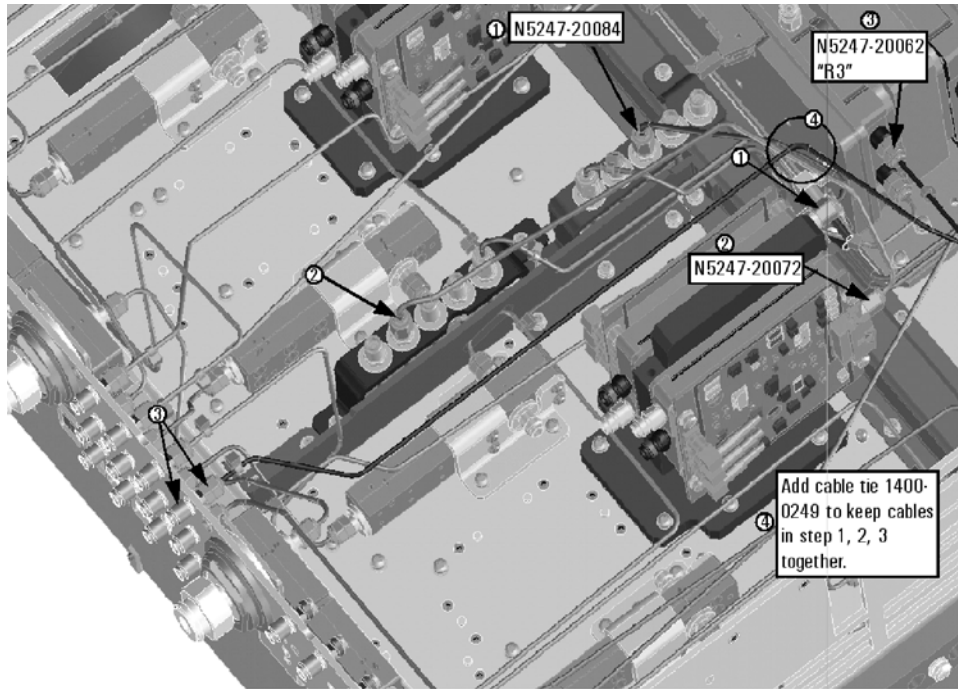


N5247 105 23

- W52 (reuse) (N5247-20012) A37 reference mixer switch to REF 1 RCVR R1 IN
- W47 (reuse) (N5247-20053) Port 1 RCVR A IN to A27 mixer brick (A)
- W34 (N5247-20082) A33 port 1 coupler to port 1 CPLR ARM
- W31 (reuse) (N5247-20037) A29 port 1 ref coupler to front-panel port 1 SOURCE OUT
- W53 (reuse) (N5247-20048) A37 reference mixer switch to A27 mixer brick (R1)
- W18 (N5247-20084) A61 port 3 70 GHz doubler to W17
- W14 (reuse) (N5247-20072) A60 port 1 70 GHz doubler to W13
- W54 (N5247-20062) REF 3 RECEIVER R3 IN to A28 mixer brick (R3)

\* As shown in [Figure 27](#), install cable tie, part number 1400-0249, to secure W18, W14, and W54 together.

**Figure 27 Location of Cable Tie to Secure W14, W18, and W54 Together**



N5247\_105\_25

- W27 (reuse) (N5247-20074) A60 port 1 70 GHz doubler to A29 port 1 reference coupler
- W28 (N5247-20052) A61 port 3 70 GHz doubler to A30 port 3 ref coupler
- W16 (N5247-20060) A61 port 3 70 GHz doubler to W15
- W12 (reuse) (N5247-20059) A60 port 1 70 GHz doubler to W11
- W112 (N5247-20029) A44 port 4 bias tee to A35 port 4 coupler
- W29 (N5247-20074) A62 port 4 70 GHz doubler to A31 port 4 reference coupler
- W20 (N5247-20015) A62 port 4 70 GHz doubler to W19
- W24 (reuse) (N5247-20061) A63 port 2 70 GHz doubler to W23
- W30 (reuse) (N5247-20052) A63 port 2 70 GHz doubler to A32 port 2 reference coupler
- W22 (N5247-20068) A62 port 4 70 GHz doubler to W21
- W26 (reuse) (N5247-20051) A63 port 2 70 GHz doubler to W25
- W63 (N5245-20023) A26 splitter to A27 mixer brick
- W64 (N5245-20022) A26 splitter to A28 mixer brick
- W62 (N5247-20111) A26 splitter to A25 HMA26.5
- \* Tighten the screws that secure the A26 splitter to the mixer mounting block.
- W58 (N5247-20138) 2.4 mm cap for A28 mixer brick

### Step 34. Install Cables on IF Multiplexer Board

Install the following gray flexible cables in the order listed. Mixer brick cables were connected to the mixer bricks earlier in this procedure, but the other ends of these cables still require a connection. To see images showing the location of these cables, click either of the Chapter 6 bookmarks “Bottom RF Cables, 4-Port, Option 400” in the PDF Service Guide<sup>1</sup>. New parts are listed in [Table 1 on page 7](#).

- W80 (N5242-60013) A24 IF multiplexer board P203 to A16 SPAM board J2
- W82 (N5242-60015) A24 IF multiplexer board P603 to A16 SPAM board J5
- W71 (reuse) (N5242-60017) A27 mixer brick (A) to A24 IF multiplexer (P1)
- W72 (N5242-60021) A27 mixer brick (R1) to A24 IF multiplexer (P411)
- W73 (N5242-60022) A27 mixer brick (R2) to A24 IF multiplexer (P412)
- W74 (reuse) (N5242-60018) A27 mixer brick (B) to A24 IF multiplexer (P201)
- W75 (N5242-60024) A28 mixer brick (D) to A24 IF multiplexer (P801)
- W76 (N5242-60019) A28 mixer brick (R4) to A24 IF multiplexer (P414)
- W77 (N5242-60020) A28 mixer brick (R3) to A24 IF multiplexer (P413)
- W78 (N5242-60023) A28 mixer brick (C) to A24 IF multiplexer (P601)
- W79 (reuse) (N5242-60012) A24 IF multiplexer board P3 to A16 SPAM board J1
- W81 (reuse) (N5242-60014) A24 IF multiplexer board P403 to A16 SPAM board J4
- W83 (reuse) (N5242-60016) A24 IF multiplexer board P803 to A16 SPAM board J6

### Step 35. Reinstall the Testset Stabilizer Bracket on the A24 IF Multiplexer Board

Reinstall the stabilizer bracket - see [Figure 1](#).

### Step 36. Reinstall the A23 Test Set Motherboard

For instructions on reinstalling the board, click the Chapter 7 bookmark “Removing and Replacing the A23 test set motherboard” in the PDF Service Guide<sup>1</sup>.

### Step 37. Install Cables on the A23 Test Set Motherboard

---

<b>CAUTION</b>	Follow instructions carefully when making cable connections, especially wire harness connections. Incorrect connections can destroy components, resulting in additional customer costs.
----------------	---

---

If not already done in a previous step, install the following new ribbon cables and wire harness in the order listed. To see an image showing their locations, click the Chapter 6 bookmark “Bottom Ribbon Cables and Wire Harnesses, 4-Port, Option 400” in the PDF Service Guide<sup>1</sup>. New parts are listed in [Table 1 on page 7](#).

1. See [“Downloading the Online PNA Service Guide” on page 5](#).

- Ribbon cable (N5247-60015) from A28 mixer brick (2) J52 to A23 test set motherboard J552
- Ribbon cable (N5247-60018), A61 port 3 70 GHz doubler J1 to A23 test set motherboard J5
- Ribbon cable (N5247-60018), A62 port 4 70 GHz doubler J1 to A23 test set motherboard J3

### **Step 38. Replace the Front Frame in the Front Panel Assembly**

Before the front frame can be replaced, the items making up the back side of the front panel assembly must be removed. For instructions on removing these items, click the Chapter 7 bookmark “Removing and Replacing the A1-A3 and Other Front Panel Subassemblies” in the PDF Service Guide<sup>1</sup>. New parts are listed in [Table 1 on page 7](#).

1. In the section “Removing the A2 USB Board,” perform the only step.
2. In the section “Removing the A1 Front Panel Interface Board and Keypad Assembly,” perform steps 1 - 5.
3. In the section “Removing the Power Switch Board and Power Button Keypad,” perform only step 1.
4. Remove the braided gasket from the backside edges of the 2-port front frame and install it in the 4-port front frame.
5. Reassemble the front panel assembly with the new 4-port front frame (N5247-20141) by reversing the order of the instructions previously followed.

### **Step 39. Reinstall Front Panel Assembly**

For instructions on reinstalling the front panel assembly, click the Chapter 7 bookmark “Removing and Replacing the Front Panel Assembly” in the PDF Service Guide<sup>1</sup>.

### **Step 40. Install the Overlays and Nameplate**

To see an image of the front panel overlay (N5247-80011), keypad overlay (N5242-80005), power button overlay (N5242-80007), and nameplate (N5247-80006), click the Chapter 6 bookmark “Front Panel Assembly, Front Side, All Options” in the PDF Service Guide<sup>1</sup>. New parts are listed in [Table 1 on page 7](#).

1. Remove the protective backing from the new front panel overlay (N5247-80011).
2. Loosely place the overlay in the recess on the lower front panel.
3. Placing two fingers at the middle, press the overlay firmly onto the frame while sliding your fingers in opposite directions towards the ends of the overlay. Repeat on all areas of the overlay.
4. Repeat steps 1-3 to install the keypad overlay (N5242-80005).
5. Repeat steps 1-3 to install the power button overlay (N5242-80007).
6. Install the new nameplate (N5247-80006).

### **Step 41. Install the Jumper Cables**

Install twelve W60 front panel jumper cables (N5247-20107) - use 6 new jumpers and reuse 6 old jumpers. To see an image of the front panel jumper cables, click the Chapter 7 bookmark “Removing and Replacing the Front Panel Assembly” in the PDF Service Guide<sup>1</sup>.

### **Step 42. Position the Cables and Wires to Prevent Pinching**

On the top side of the PNA, carefully position the grey flex cables so they can't be pinched between the covers and the rails.

On the bottom side of the PNA, carefully fold or push down the ribbon cables and wires so they can't be pinched between the hardware and the outer cover. Ribbon cables and wires must never be positioned on top of hardware.

### **Step 43. Reinstall the Inner Cover**

For instructions, click the Chapter 7 bookmark "Removing the Covers" in the PDF Service Guide<sup>1</sup>.

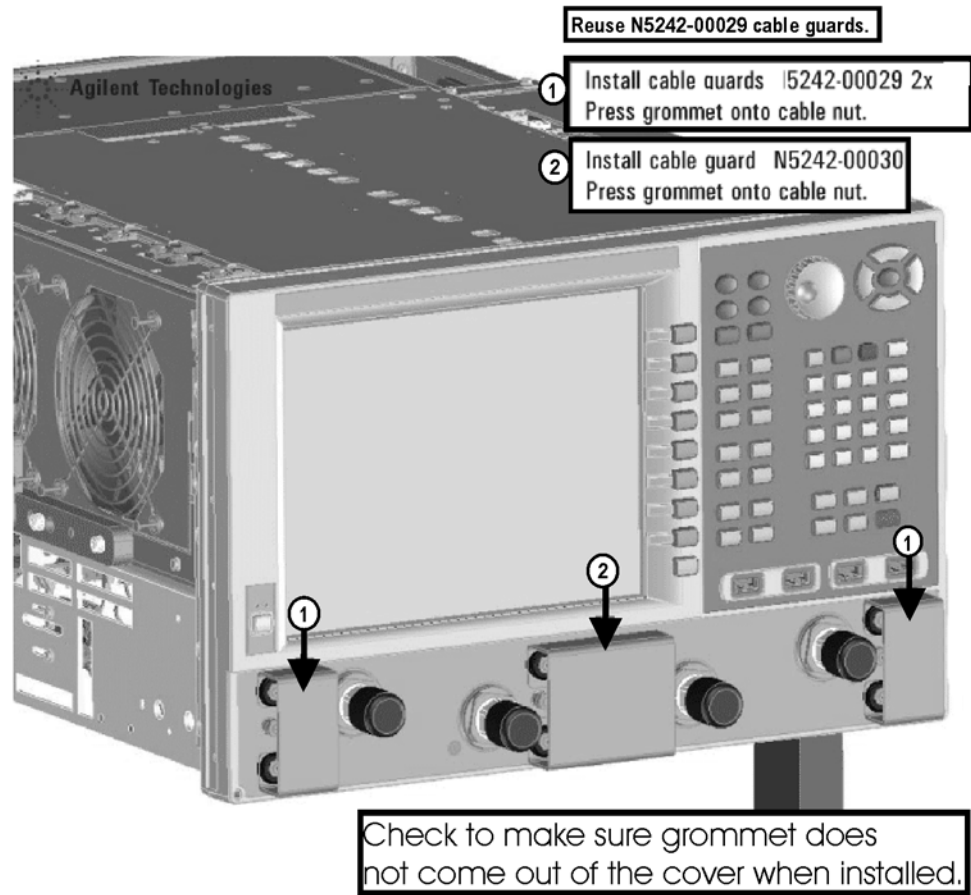
### **Step 44. Reinstall the Outer Cover**

For instructions, click the Chapter 7 bookmark "Removing the Covers" in the PDF Service Guide<sup>1</sup>.

### **Step 45. Install the Cable Guards Over the Front Panel Jumpers**

Follow the three instructions shown in [Figure 28](#).

**Figure 28**    **Install the Cable Guards Over the Front Panel Jumpers**



N5247\_105\_09

## Step 46. Enable Options P04 (400)

### Procedure Requirements

- The analyzer must be powered up and operating to perform this procedure.
- The network analyzer program must be running.
- A keyboard and mouse must be connected to the network analyzer.

### Option Enable Procedure

1. To start the option enable utility, press UTILITY **System** , then **Service** , then **Option Enable** . An option enable dialog box will appear.
2. Click the arrow in the **Select Desired Option** box. A list of available options will appear.
3. In the **Select Desired Option** list, click **P04 - 4-Ports**.
4. Using the keyboard, enter the license key in the box provided. The license key is printed on the the license message you received from Keysight. Enter this key *exactly* as it is printed on the message.
5. Click **Enable**.
6. Click **Yes** in answer to the displayed question in the **Restart Analyzer?** box.
7. When the installation is complete, click **Exit**.

### Option Verification Procedure

Once the analyzer has restarted and the Network Analyzer program is again running:

1. On the analyzer's **Help** menu, click **About Network Analyzer**.
2. Verify that "P04" is listed after "Options:" in the display. Click **OK**.

---

**NOTE** If the option has not been enabled, perform the "Option Enable Procedure" again. If the option is still not enabled, contact Keysight Technologies. Refer to "Getting Assistance from Keysight" on page 3.

---

## Step 47. Perform Post-Upgrade Adjustments and Calibration

### Adjustments

The following adjustments must be made due to the hardware changes of the analyzer.

- default EE
- source adjustment
- receiver adjustment
- receiver characterization

These adjustments are described in the PNA Service Guide and in the PNA on-line HELP. A list of equipment required to perform these adjustments is also found in the service guide.

After the specified adjustments have been performed, the analyzer should operate and phase lock over its entire frequency range.

### Operator's Check

Perform the Operator's Check to check the basic functionality of the analyzer. For instructions, click the Chapter 3 bookmark "Tests and Adjustments" in the PDF Service Guide<sup>1</sup>.

If you experience difficulty with the basic functioning of the analyzer, contact Keysight. Refer to "[Contacting Keysight](#)" on page 3.

### Calibration

Although the analyzer functions, its performance relative to its specifications has not been verified. It is recommended that a full instrument calibration be performed using the analyzer's internal performance test software. To view information on the performance test software, click the Chapter 3 bookmark "Tests and Adjustments" in the PDF Service Guide<sup>1</sup>.

## Step 48. Prepare the PNA for the User

1. If necessary, reinstall front jumper cables.
2. Install the cable guards, pushing them over the front jumper cables until the cushioning material touches the front panel of the PNA.
3. Install the dust caps on the test ports.
4. Clean the analyzer, as needed, using a damp cloth.

---

1. See "[Downloading the Online PNA Service Guide](#)" on page 5.





This information is subject to change without notice.

© Keysight Technologies 2011, 2014

December 1, 2014



N5247-90105  
[www.keysight.com](http://www.keysight.com)