

# Keysight Add 4-Port Capability Upgrade Kit

To Upgrade PNA-X N5247A Option 224 to Option 423  
Upgrade Kit Order Number: N5247AU- 944  
Keysight Kit Number: N5247-60107

NOTICE: This document contains references to Agilent Technologies. Agilent's former Test and Measurement business has become Keysight Technologies. For more information, go to [www.keysight.com](http://www.keysight.com).



---

## WARRANTY STATEMENT

THE MATERIAL CONTAINED IN THIS DOCUMENT IS PROVIDED "AS IS," AND IS SUBJECT TO BEING CHANGED, WITHOUT NOTICE, IN FUTURE EDITIONS. FURTHER, TO THE MAXIMUM EXTENT PERMITTED BY APPLICABLE LAW, KEYSIGHT DISCLAIMS ALL WARRANTIES, EITHER EXPRESS OR IMPLIED WITH REGARD TO THIS MANUAL AND ANY INFORMATION CONTAINED HEREIN, INCLUDING BUT NOT LIMITED TO THE IMPLIED WARRANTIES OF MERCHANTABILITY AND FITNESS FOR A PARTICULAR PURPOSE. KEYSIGHT SHALL NOT BE LIABLE FOR ERRORS OR FOR INCIDENTAL OR CONSEQUENTIAL DAMAGES IN CONNECTION WITH THE FURNISHING, USE, OR PERFORMANCE OF THIS DOCUMENT OR ANY INFORMATION CONTAINED HEREIN. SHOULD KEYSIGHT AND THE USER HAVE A SEPARATE WRITTEN AGREEMENT WITH WARRANTY TERMS COVERING THE MATERIAL IN THIS DOCUMENT THAT CONFLICT WITH THESE TERMS, THE WARRANTY TERMS IN THE SEPARATE AGREEMENT WILL CONTROL.

---

## DFARS/Restricted Rights Notice

If software is for use in the performance of a U.S. Government prime contract or subcontract, Software is delivered and licensed as "Commercial computer software" as defined in DFAR 252.227-7014 (June 1995), or as a "commercial item" as defined in FAR 2.101(a) or as "Restricted computer software" as defined in FAR 52.227-19 (June 1987) or any equivalent agency regulation or contract clause. Use, duplication or disclosure of Software is subject to Keysight Technologies' standard commercial license terms, and non-DOD Departments and Agencies of the U.S. Government will receive no greater than Restricted Rights as defined in FAR 52.227-19(c)(1-2) (June 1987). U.S. Government users will receive no greater than Limited Rights as defined in FAR 52.227-14 (June 1987) or DFAR 252.227-7015 (b)(2) (November 1995), as applicable in any technical data.

---

## Safety Notes

The following safety notes are used throughout this document. Familiarize yourself with each of these notes and its meaning before performing any of the procedures in this document.

---

<b>WARNING</b>	<b>Warning denotes a hazard. It calls attention to a procedure which, if not correctly performed or adhered to, could result in injury or loss of life. Do not proceed beyond a warning note until the indicated conditions are fully understood and met.</b>
----------------	---

---

<b>CAUTION</b>	Caution denotes a hazard. It calls attention to a procedure that, if not correctly performed or adhered to, could result in damage to or destruction of the instrument. Do not proceed beyond a caution sign until the indicated conditions are fully understood and met.
----------------	---

---

---

## Description of the Upgrade

This upgrade converts your N5247A Option 224 2-port analyzer to an N5247A Option 423 4-port analyzer by adding:

- an additional mechanical switch
- an additional mixer brick
- two additional reference couplers and brackets
- two additional test port couplers
- two additional bias tees
- two additional source attenuators and brackets
- two additional receiver attenuators and brackets
- three additional braces for microcircuits
- two additional cable guards for front panel jumpers
- a splitter
- a modified front panel
- many additional new cables

---

## Getting Assistance from Keysight

Installing this upgrade kit requires special skills and experience. If you think you may not be qualified to do the work, or need advice, contact Keysight.

### Contacting Keysight

Assistance with test and measurements needs and information on finding a local Keysight office are available on the Web at:

<http://www.keysight.com/find/assist>

If you do not have access to the Internet, please contact your Keysight field engineer.

---

**NOTE** In any correspondence or telephone conversation, refer to the Keysight product by its model number and full serial number. With this information, the Keysight representative can determine whether your product is still within its warranty period.

---

---

## Getting Prepared

---

**CAUTION** The PNA contains extremely sensitive components that can be ruined if mishandled. Follow instructions carefully when making cable connections, especially wire harness connections.

The person performing the work accepts responsibility for the full cost of the repair or replacement of damaged components.

---

To successfully install this upgrade kit, you will need the following:

- A license key - refer to “[License Key Redemption](#)” below.
- A PDF copy or a paper copy of the PNA Service Guide - refer to “[Downloading the Online PNA Service Guide](#)” below.
- An ESD-safe work area - refer to “[Protecting Your Workspace from Electrostatic Discharge](#)” below.
- Correct tools - refer to “[Tools Required for the Installation](#)” on page 6.
- Enough time - refer to “[About Installing the Upgrade](#)” on page 6.
- Test equipment for the post-upgrade adjustments and full instrument calibration. To view the equipment list, click the Chapter 3 bookmark “[Tests and Adjustments](#)” in the PDF Service Guide<sup>1</sup>.

## License Key Redemption

---

**NOTE** The enclosed Option Entitlement Certificate is a receipt, verifying that you have purchased a licensed option for the PNA of your choice. You must now use a Keysight Web page to request a license key for the instrument that will receive the option.

---

To enable the option product, you must request a license key from: <http://www.keysight.com/find/softwarelicense>. To complete the request, you will need to gather the following information:

- From the certificate
  - Order number
  - Certificate number
- From your instrument
  - Model number
  - Serial number
  - Host ID

The instrument information is available on the network analyzer – on the analyzer’s **Help** menu, click **About Network Analyzer**.

If you provide an email address, Keysight will promptly email your license key. Otherwise, you will receive your license key via postal mail.

---

1. See “[Downloading the Online PNA Service Guide](#)” on page 5.

## Downloading the Online PNA Service Guide

To view the online Service Guide for your PNA model number, use the following steps:

1. Go to [www.keysight.com](http://www.keysight.com).
2. In the Search box, enter the model number of the analyzer (Ex: N5247A) and click **Search**.
3. Click **Technical Support > Manuals**.
4. Click **Service Manual**.
5. Click the service guide title to download the PDF file.
6. When the PDF of the Service Guide is displayed, scroll through the Contents section bookmarks to locate the information needed.

## Protecting Your Workspace from Electrostatic Discharge

For information, click on the Chapter 1 bookmark, “Electrostatic Discharge Protection” in the PDF Service Guide<sup>1</sup>.

### ESD Equipment Required for the Installation

Description	Keysight Part Number
ESD grounding wrist strap	9300-1367
5-ft grounding cord for wrist strap	9300-0980
2 x 4 ft conductive table mat and 15-ft grounding wire	9300-0797
ESD heel strap (for use with conductive floors)	9300-1308

1. See “[Downloading the Online PNA Service Guide](#)” on page 5.

## Tools Required for the Installation

Description	Qty	Part Number
T-6 TORX driver - set to 4 in-lbs (0.45 N.m)	1	N/A
T-8 TORX driver - set to 6 in-lbs (0.68 N.m)	1	N/A
T-10 TORX driver - set to 9 in-lbs (1.02 N.m)	1	N/A
T-20 TORX driver - set to 21 in-lbs (2.38 N.m)	1	N/A
5/16-in (8 mm) nutsetter or open end torque wrench- set to 10 in-lbs (1.13 N.m)	1	N/A
5/16-in (8 mm) nutsetter or open end torque wrench - set to 21 in-lbs (2.38 N.m)	1	N/A
3/16-in (5 mm) nutsetter or open end torque wrench - set to 6 in-lbs (0.68 N.m)	1	N/A
5/8-in (16 mm) nutsetter or open end torque wrench - set to 21 in-lbs (2.38 N.m)	1	N/A
9 mm nutsetter or open end torque wrench - set to 21 in-lbs (2.38 N.m)	1	N/A
1-in (25.4 mm) torque wrench - set to 72 in-lbs (8.15 N.m)	1	N/A
1/4-in (6 mm) open end wrench	1	N/A

**CAUTION** Use a 5/16-in torque wrench set to 10 in-lbs on all cable connections except the front and rear panel cable connectors. On these, use a 9 mm nutsetter or open end torque wrench set to 21 in-lb.

## About Installing the Upgrade

Products affected . . . . .	N5247A Option 224
Installation to be performed by . . . . .	Keysight service center or personnel qualified by Keysight
Estimated installation time . . . . .	5 hours
Estimated adjustment time . . . . .	2 hours
Estimated full instrument calibration time . . . . .	4.5 hours

## Items Included in the Upgrade Kit<sup>1</sup>

Check the contents of your kit against the following list. If any part is missing or damaged, contact Keysight Technologies. Refer to .

**Table 1 Contents of Upgrade Kit N5247-60107**

Ref Desig.	Description	Qty	Part Number
-	Installation note (this document)	1	N5247-90107
A28	Mixer brick (2)	1	5087-7337
A30	Test port 3 reference coupler	2	5087-7744
A31	Test port 4 reference coupler		
A34	Test port 3 coupler	2	5087-7778
A35	Test port 4 coupler		
A39	Test port 3 source attenuator	2	84905-60002
A40	Test port 4 source attenuator		
A43	Test port 3 bias tee	2	5087-7732
A44	Test port 4 bias tee		
A47	Test port 3 receiver attenuator	2	84905-60002
A48	Test port 4 receiver attenuator		
A52	Port 4 mechanical switch	1	N1811-60010
A26	Splitter	1	5067-4086
A69	3 dB pad, attached to R4 connector on A28 mixer brick	1	08490-60037
-	Front frame, 4-port	1	N5247-20141
-	Bulkhead connector, rear panel (2) and front panel (12)	14	5065-4673
-	Washer for bulkhead connectors, rear panel (2) and front panel (12)	14	1250-3310
-	Nut for bulkhead connectors, rear panel (2) and front panel (12)	14	1250-3516
-	Machine screw, M2.5 x 20, pan head (2 to attach brace to 70 GHz doubler mount)	2	0515-0380
-	Machine screw, M2.5 x 20, pan head (2 to attach mechanical switch to bracket)	2	0515-0375
-	Machine screw, M2.0 x 6, flat head (8 to attach 2 reference couplers to brackets)	8	0515-0658
-	Machine screw, M3.0 x 25, pan head (3 to attach mixer brick A28 to mounting block)	3	0515-1038
-	Machine screw, M3.0 x 8, pan head (8 to attach port 3 and port 4 attenuator assemblies to deck; 8 to attach 2 src attn and 2 rcvr attn to brackets; 6 to attach reference coupler assemblies to attenuator assembly brackets; 4 to attach brace N5247-20134 to attenuator pair brackets; 4 to attach brace N5247-20133 to attenuator pair brackets)	30	0515-0372
-	Machine screw, M2.5 x 16, pan head (2 to attach splitter to mixer brick)	2	0515-2007
-	Machine screw, M3.0 x 6, pan head (2 to install combiner bracket to port 1 attenuator pair bracket)	2	0515-0430

1. In addition to the upgrade kit, the shipment includes an Option Entitlement Certificate. Refer to ["License Key Redemption"](#) on page 4 for important information about this certificate.



**Table 1 Contents of Upgrade Kit N5247-60107**

Ref Desig.	Description	Qty	Part Number
-	Machine screw, M3.0 x 14, pan head (4 to attach 2 bias tees to blocks)	4	0515-1227
-	Front panel overlay (label), 4-port	1	N5247-80002
-	Keypad overlay (label)	1	N5242-80005
-	Power button overlay (label)	1	N5242-80007
-	Nameplate, N5247A	1	N5242-80006
-	Test set front plate, 4-port	1	N5247-00009
-	Pad (between each reference coupler and the bracket for the attenuator pairs)	2	0403-0179
-	Gap pad (between each test coupler and the test set front plate)	4	E4403-20033
--	Termination, 2.4 mm 50 GHz load	1	0955-2394
-	Vibration mount (between couplers 1 & 3, and 2 & 4)	2	0460-2725
-	Mounting nuts (for port 3 & 4 test port couplers)	2	5022-1087
-	Cable guard, center jumper cables	1	N5242-00030
-	Cable guard, port 1 jumper cables	1	N5247-00018
-	Cable clamp, 1 to secure W145 (N5247-20066); 1 to secure both W137 (N5247-20097) and W138 (N5247-20098); 1 to secure W41 (N5247-20069); 1 to secure W37 (N5247-20070).	4	1400-1334
-	Cable tie wrap, 1 to secure W55 (N5247-20067); 1 to secure W37 (N5247-20070); 1 to secure W54 (N5247-20062); 2 to secure W144 (N5247-20071).	5	1400-0249
-	Bracket for reference coupler, port 3	1	N5247-00012
-	Bracket for reference coupler, port 4	1	N5247-00011
-	Bracket for receiver attenuator and source attenuator pairs	2	N5247-00005
-	Brace, bottom side of PNA	1	N5247-20133
-	Brace, bottom side of PNA	2	N5247-20134
W34	RF cable, A33 port 1 coupler to front-panel Port 1 CPLR ARM	1	N5247-20082
W37	RF cable, A30 port 3 ref coupler to front-panel REF 3 SOURCE OUT	1	N5247-20070
W38	RF cable, A34 port 3 coupler to front-panel Port 3 CPLR ARM	1	N5247-20007
W41	RF cable, A31 port 4 ref coupler to front-panel REF 4 SOURCE OUT	1	N5247-20069
W42	RF cable, A35 port 4 coupler to front-panel Port 4 CPLR ARM	1	N5247-20026
W46	RF cable, A36 port 2 coupler to front-panel port 2 CPLR ARM	1	N5247-20019
W54	RF cable, REF 3 RCVR R3 IN to A28 mixer brick (R3)	1	N5247-20062
W55	RF cable, REF 4 RCVR R4 IN to A28 mixer brick (R4)	1	N5247-20067
W58	RF cable, 2.4 mm cap for A28 mixer brick	1	N5247-20138
W60	RF cable, Front panel jumper	6	N5247-20107
W62	RF cable, A25 HMA26.5 to A26 splitter	1	N5247-20111
W63	RF cable, A26 splitter to A27 mixer brick	1	N5245-20023
W64	RF cable, A26 splitter to A28 mixer brick	1	N5245-20022
W72	RF cable, A27 mixer brick (R1) to A24 IF multiplexer (P411)	1	N5242-60021
W73	RF cable, A27 mixer brick (R2) to A24 IF multiplexer (P412)	1	N5242-60022

**Table 1 Contents of Upgrade Kit N5247-60107**

Ref Desig.	Description	Qty	Part Number
W75	RF cable, A28 mixer brick (D) to A24 IF multiplexer (P801)	1	N5242-60024
W76	RF cable, A28 mixer brick (R4) to A24 IF multiplexer (P414)	1	N5242-60019
W77	RF cable, A28 mixer brick (R3) to A24 IF multiplexer (P413)	1	N5242-60020
W78	RF cable, A28 mixer brick (C) to A24 IF multiplexer (P601)	1	N5242-60023
W80	RF cable, A24 IF multiplexer board P203 to A16 SPAM board J2	1	N5242-60013
W82	RF cable, A24 IF multiplexer board P603 to A16 SPAM board J5	1	N5242-60015
W103	RF cable, front-panel Port 1 CPLR THRU to A42 port 1 bias tee	1	N5247-20081
W104	RF cable, A33 port 1 coupler to A42 port 1 bias tee	1	N5247-20022
W105	RF cable, A30 port 3 reference coupler to A39 port 3 source attenuator	1	N5247-20083
W106	RF cable, A39 port 3 source attenuator to front-panel Port 3 SOURCE OUT	1	N5247-20009
W108	RF cable, A43 port 3 bias tee to A34 port 3 coupler	1	N5247-20028
W109	RF cable, A31 port 4 reference coupler to A40 port 4 source attenuator	1	N5247-20083
W110	RF cable, A40 port 4 source attenuator to front-panel Port 4 SOURCE OUT	1	N5247-20025
W111	RF cable, Port 4 CPLR THRU to A44 port 4 bias tee	1	N5247-20021
W112	RF cable, A44 port 4 bias tee to A35 port 4 coupler	1	N5247-20029
W116	RF cable, A45 port 2 bias tee to A36 port 2 coupler	1	N5247-20080
W119	RF cable, Port 3 RCVR C IN to A47 port 3 receiver attenuator	1	N5247-20008
W120	RF cable, A47 port 3 receiver attenuator to A28 mixer brick (C)	1	N5247-20064
W121	RF cable, Port 4 RCVR D IN to A48 port 4 receiver attenuator	1	N5247-20024
W122	RF cable, A48 port 4 receiver attenuator to A28 mixer brick (D)	1	N5247-20065
W127	RF cable, A50 port 1 mechanical switch to PORT 1 SW SRC OUT	1	N5247-20091
W128	RF cable, front-panel PORT 1 COMB THRU IN to A54 combiner	1	N5247-20092
W129	RF cable, front-panel PORT 3 COMB ARM IN to A54 combiner	1	N5247-20093
W130	RF cable, A50 port 1 mechanical switch to A54 combiner	1	N5247-20094
W132	RF cable, A51 port 3 mechanical switch to A30 port 3 reference coupler	1	N5247-20033
W133	RF cable, A51 port 3 mechanical switch to PORT 3 SW SRC OUT	1	N5247-20090
W135	RF cable, A52 port 4 mechanical switch to A62 port 4 70 GHz doubler	1	N5247-20030
W136	RF cable, A52 port 4 mechanical switch to A31 port 4 reference coupler	1	N5247-20031
W137	RF cable, A52 port 4 mechanical switch to PORT 4 SW SRC OUT (J4)	1	N5247-20097
W138	RF cable, A52 port 4 mechanical switch to PORT 4 SW TSET (J3)	1	N5247-20098
W143	RF cable, rear panel jumper	1	N5247-20107
W144	RF cable, A29 port 1 reference coupler to A37 reference mixer switch	1	N5247-20071
W145	RF cable, REF 2 RCVR R2 IN to A27 mixer brick (R2)	1	N5247-20066
-	Ribbon cable, A23 test set motherboard J547 to A39 port 3 source attenuator	2	N5245-60006
-	Ribbon cable, A23 test set motherboard J548 to A40 port 4 source attenuator		
-	Ribbon cable, A23 test set motherboard J206 to A47 port 3 receiver attenuator	2	N5247-60020
-	Ribbon cable, A23 test set motherboard J207 to A48 port 4 receiver attenuator		

**Table 1**      **Contents of Upgrade Kit N5247-60107**

<b>Ref Desig.</b>	<b>Description</b>	<b>Qty</b>	<b>Part Number</b>
-	Ribbon cable, A23 test set motherboard J552 to A28 mixer brick (2) J52	1	N5247-60015
-	Wire harness, A43 port 3 bias tee to A23 test set motherboard J543	2	N5247-60021
-	Wire harness, A44 port 4 bias tee to A23 test set motherboard J544		

---

**NOTE**      Extra quantities of items such as protective plastic caps, screws, cable ties, and cable clamps may be included in this upgrade kit. It is normal for some of these items to remain unused after the upgrade is completed.

---

---

## Installation Procedure for the Upgrade

The network analyzer must be in proper working condition prior to installing this option. Any necessary repairs must be made before proceeding with this installation.

---

**WARNING**      **This installation requires the removal of the analyzer's protective outer covers. The analyzer must be powered down and disconnected from the mains supply before performing this procedure.**

---

### Overview of the Installation Procedure

- Step 1. Obtain a Keyword and Verify the Information.
- Step 2. Remove the Outer Cover.
- Step 3. Remove the Inner Cover.
- Step 4. Remove the Front Panel Jumper Cables and Cable Guards.
- Step 5. Remove the Front Panel Assembly.
- Step 6. Remove the Braces on the Bottom Side of the PNA.
- Step 7. Remove the A23 Test Set Motherboard.
- Step 8. Remove the A24 IF Multiplexer Board.
- Step 9. Install Two New Bulkhead Connectors and a Termination on the Rear Panel.
- Step 10. Remove Some Bottom-Side (Test Set) Cables.
- Step 11. Remove the A27 Mixer Brick Assembly.
- Step 12. Assemble the A28 Mixer Brick Assembly.
- Step 13. Install the A27/A28 Mixer Brick Assemblies.
- Step 14. Assemble the Port 3 and Port 4 Attenuator Assemblies.
- Step 15. Install the Port 3 and Port 4 Attenuator Assemblies on the Test Set Deck.
- Step 16. Assemble the A30 and A31 Reference Coupler Assemblies.
- Step 17. Install the A30 and A31 Reference Coupler Assemblies.
- Step 18. Relocate the A54 Combiner Assembly.
- Step 19. Remove the Bias Tee Blocks From the Test Set Deck.
- Step 20. Install the A43 and A44 Bias Tees on the Bias Tee Blocks.
- Step 21. Reinstall the Bias Tee Blocks.
- Step 22. Remove the A53 Mechanical Switch/Bracket Assembly from the Test Set Deck.
- Step 23. Install the A52 Mechanical Switch on the Bracket.
- Step 24. Reinstall the A52/A53 Mechanical Switch Assembly On the Test Set Deck.
- Step 25. Assemble the A33 - A36 Test Port Coupler Assemblies.

- Step 26. Remove and Disassemble the 2-Port Test Set Front Plate.
- Step 27. Install the LED Boards, Bulkhead Connectors, and Test Port Coupler Assemblies to the 4-Port Test Set Front Plate.
- Step 28. Install the 4-Port Coupler Plate Assembly to the Deck.
- Step 29. Install Some Bottom-Side (Test Set) Cables.
- Step 30. Reinstall the A24 IF Multiplexer Board.
- Step 31. Install Cables on IF Multiplexer Board.
- Step 32. Reinstall the A23 Test Set Motherboard.
- Step 33. Install Cables on the A23 Test Set Motherboard.
- Step 34. Install the Braces on the Bottom Side of the PNA.
- Step 35. Replace the Front Frame in the Front Panel Assembly.
- Step 36. Reinstall Front Panel Assembly.
- Step 37. Install the Overlays and Nameplate.
- Step 38. Install the Jumper Cables.
- Step 39. Position the Cables and Wires to Prevent Pinching.
- Step 40. Reinstall the Inner Cover.
- Step 41. Reinstall the Outer Cover.
- Step 42. Remove Option 224 and Option 219 Licenses.
- Step 43. Enable Options P04 (400), 419, and 423.
- Step 44. Perform Post-Upgrade Adjustments and Calibration.
- Step 45. Prepare the PNA for the User.

## **Step 1. Obtain a Keyword and Verify the Information**

Follow the instructions on the Option Entitlement Certificate supplied to obtain a license key for installation of this upgrade. Refer to [“License Key Redemption” on page 4](#).

Verify that the model number, serial number, and option number information on the license key match those of the instrument on which this upgrade will be installed.

If the model number, serial number, or option number do not match those on your license key, you will not be able to install the option. If this is the case, contact Keysight for assistance before beginning the installation of this upgrade. Refer to [“Contacting Keysight” on page 3](#).

Once the license key has been received and the information verified, you can proceed with the installation at step 2.

## **Step 2. Remove the Outer Cover**

For instructions, click the Chapter 7 bookmark “Removing the Covers” in the PDF Service Guide<sup>1</sup>.

## **Step 3. Remove the Inner Cover**

For instructions, click the Chapter 7 bookmark “Removing the Covers” in the PDF Service Guide<sup>1</sup>.

## **Step 4. Remove the Front Panel Jumper Cables and Cable Guards**

1. Pull the two cable guards off of the front panel jumper cables. Discard one but save the other for reinstallation later.
2. Remove all front panel jumper cables. Keep for reinstallation later.

## **Step 5. Remove the Front Panel Assembly**

For instructions, click the Chapter 7 bookmark “Removing and Replacing the Front Panel Assembly” in the PDF Service Guide<sup>1</sup>.

## **Step 6. Remove the Braces on the Bottom Side of the PNA**

1. Remove the three braces shown in [Figure 1](#).
2. Discard brace N5247-20131 and the screws that secure it.
3. Keep both of the N5247-20132 braces and their screws for reinstallation later.

---

1. See [“Downloading the Online PNA Service Guide” on page 5](#).

**Figure 1 Braces on Bottom Side of Option 224 PNA**

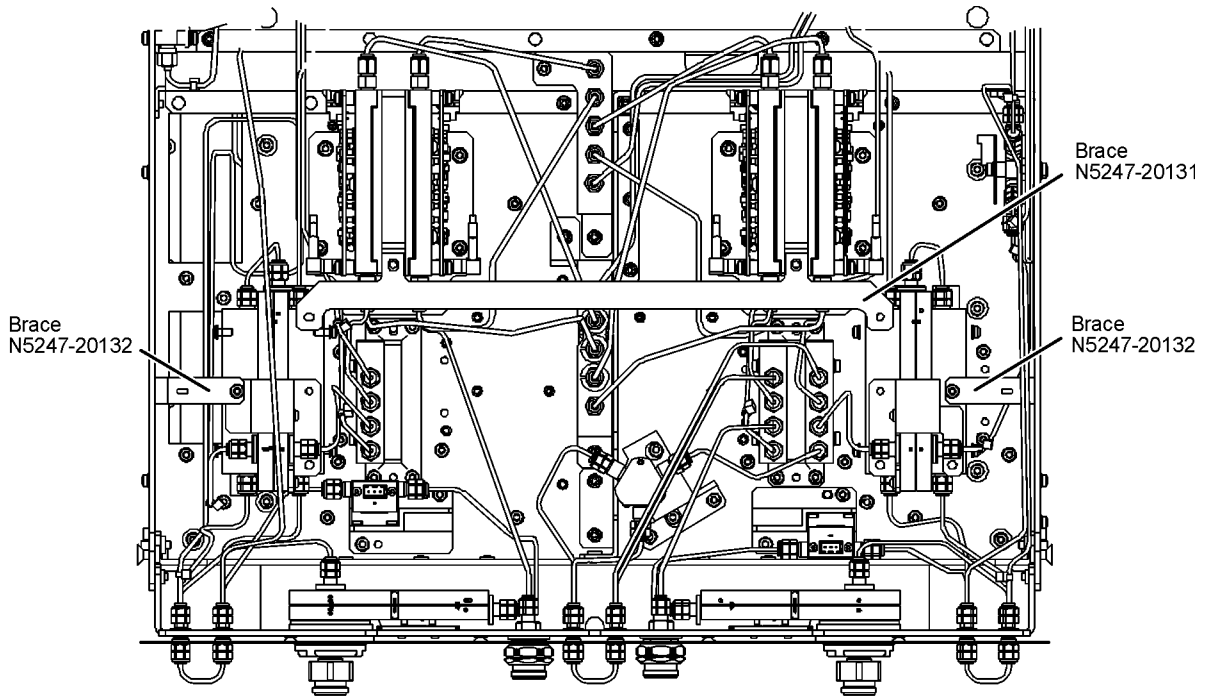

n5247\_107\_33

### **Step 7. Remove the A23 Test Set Motherboard**

For instructions, click the Chapter 7 bookmark “Removing and Replacing the A23 Test Set Motherboard” in the PDF Service Guide<sup>1</sup>.

### **Step 8. Remove the A24 IF Multiplexer Board**

For instructions, click the Chapter 7 bookmark “Removing and Replacing the A24 IF Multiplexer Board” in the PDF Service Guide<sup>1</sup>.

### **Step 9. Install Two New Bulkhead Connectors and a Termination on the Rear Panel**

1. Install a new bulkhead connector, nut and washer into the rear panel holes labeled:
  - SW SRC OUT (J4)
  - SW TSET IN (J3)
2. Torque both connectors to 21 in-lbs.
3. Install the 2.4 mm 50 GHz termination (0955-2394) on J7, port 3.
4. Torque the termination to 10 in-lbs

## Step 10. Remove Some Bottom-Side (Test Set) Cables

**CAUTION** Be careful not to damage the center pins of the semirigid cables. Some flexing of the cables may be necessary but do not over-bend them.

**NOTE** When removing a cable, also remove the plastic cable clamp, if present. It is normal for some of the cable clamp's adhesive to remain.

1. Place the analyzer bottom-side up on a flat surface.
2. Remove all bottom-side cables (gray flexible and silver semi-rigid) except for those in the following table. Do not discard the cables that are removed because some will be reused later in the procedure. To see an image showing the location of cables W11, W13, W15, W17, W19, W21, W23, W25, W61, W65 and W67 click the Chapter 6 bookmark "Top Cables, All Cables - All Options" in the PDF Service Guide<sup>1</sup>. To see an image showing the location of the other cables, click the Chapter 6 bookmark "Bottom RF Cables, 2-Port, Option 224" in the PDF Service Guide<sup>1</sup>.

<b>Do Not Remove These Bottom-Side Cables</b>				
<b>Reference Designator</b>	<b>Type<sup>a</sup></b>	<b>Part Number</b>	<b>Qty</b>	<b>Description</b>
W11	SR	N5247-20114	1	A7 port 1 40 GHz doubler P6 to W12
W13	SR	N5247-20086	1	A7 port 1 40 GHz doubler P2 to W14
W15	SR	N5247-20114	1	A12 port 3 40 GHz doubler P6 to W16. (On 2-port models, W15 is included only with Option 224.)
W17	SR	N5247-20086	1	A12 port 3 doubler P2 to W18 (On 2-port models, W17 is included only with Option 224.)
W19	SR	N5247-20114	1	A13 port 4 40 GHz doubler P6 to W20 (On 2-port models, W19 is included only with Option 224.)
W21	SR	N5247-20086	1	A13 port 4 40 GHz doubler P2 to W22 (On 2-port models, W21 is included only with Option 224.)
W23	SR	N5247-20114	1	A8 port 2 40 GHz doubler P6 to W24
W25	SR	N5247-20086	1	A8 port 2 40 GHz doubler P2 to W26
W61	SR	N5247-20110	1	A15 13.5 GHz (LO) synthesizer board J1207 to A25 HMA26.5
W65	SR	N5247-20113	1	A7 port 1 40 GHz doubler P5 to W66
W66	SR	N5247-20109	1	W65 to rear-panel EXT TSET DRIVE RF OUT (J6)
W67	SR	N5247-20096	1	A12 port 3 40 GHz doubler P5 to W68 (On 2-port models, W67 is included only with Option 224.)
W68	SR	N5247-20088	1	Rear-panel port RF2 OUT (J12) to W67
W69	SR	N5247-20112	1	A27 mixer brick to rear-panel EXT TSET DRIVE LO OUT (J5)
W91	SR	N5247-60006	1	A60 port 1 70 GHz doubler J2 to A7 40 GHz doubler J401

1. See "Downloading the Online PNA Service Guide" on page 5.



## Do Not Remove These Bottom-Side Cables

Reference Designator	Type <sup>a</sup>	Part Number	Qty	Description
W92	SR	N5247-60007	1	A60 port 1 70 GHz doubler J4 to A7 40 GHz doubler J500
W93	SR	N5247-60010	1	A51 port SRC 2 OUT 1 70 GHz dblr J2 to A12 40 GHz dblr J401
W94	SR	N5247-60011	1	A51 port SRC 2 OUT 1 70 GHz dblr J4 to A12 40 GHz dblr J500
W95	SR	N5247-60012	1	A62 port SRC 2 OUT 2 70 GHz dblr J2 to A13 40 GHz dblr J401
W96	SR	N5247-60013	1	A62 port SRC 2 OUT 2 70 GHz dblr J4 to A13 40 GHz dblr J500
W97	SR	N5247-60008	1	A63 port port 2 70 GHz dblr J2 to A8 40 GHz dblr J401
W98	SR	N5247-60009	1	A63 port port 2 70 GHz dblr J4 to A8 40 GHz dblr J500
W134	SR	N5247-20095	1	Rear-panel PORT 3 SW TSET IN (J7) to A51 SRC2 OUT1 m. switch
W141	SR	N5247-20099	1	A53 port 2 mechanical switch to PORT 2 SW SRC OUT (J2)

a. SR = semirigid coaxial cable.

3. Remove and discard the following gray flexible cables that have a top-side connection:
  - W99 (N5247-60023) A16 SPAM board (J2) to A24 IF multiplexer (P603)
  - W100 (N5247-60024) A16 SPAM board (J5) to A24 IF multiplexer (P203)
4. Leave the remaining gray flexible cables, the wire harnesses, and the ribbon cables connected where possible. Any that are removed should be labeled for reconnection later.

### Step 11. Remove the A27 Mixer Brick Assembly

Remove the A27 mixer brick assembly from the PNA. For instructions, click the Chapter 7 bookmark, "Removing and Replacing the A27 and A28 Mixer Bricks" in the PDF Service Guide<sup>1</sup>.

1. See ["Downloading the Online PNA Service Guide" on page 5.](#)

## Step 12. Assemble the A28 Mixer Brick Assembly

1. Follow the instruction shown in [Figure 2](#). New parts are listed in [Table 1 on page 7](#) of this document.

**Figure 2** A28 Mixer Brick Assembly

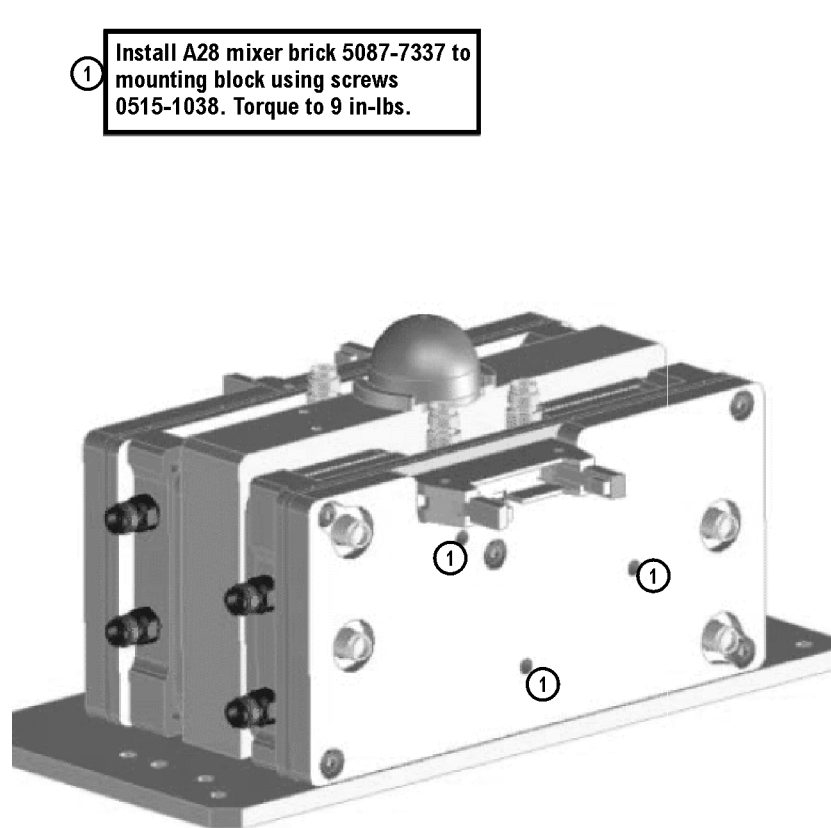

N5247\_107\_17

2. Follow the two instructions shown in [Figure 3](#).

**Figure 3 A26 Splitter and A69 3 dB Pad Installation**

① Install splitter 5067-4086 (label facing up), secure with screws 0515-2007 X2. Leave loose for now.

② Install 3dB pad 08490-60037 X1 only on R4 connector of A28 mixer brick. Torque to 10 in-lbs.

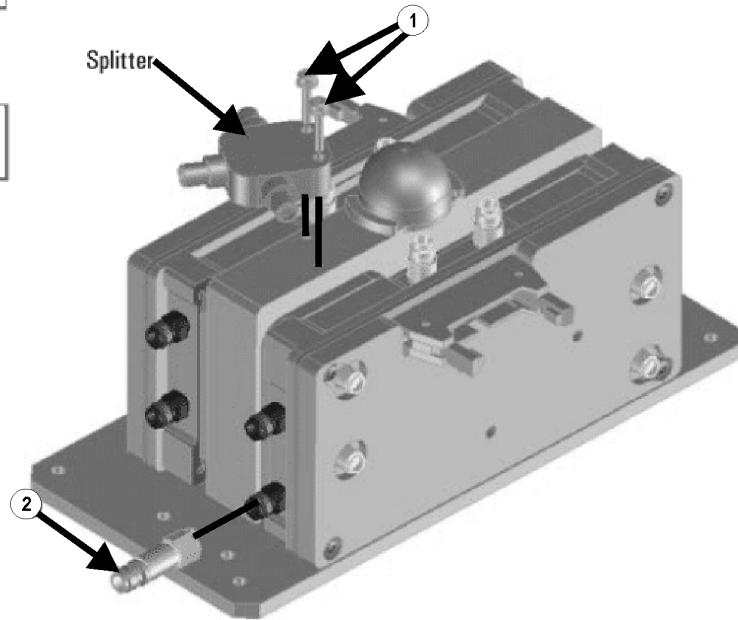

N5247\_107\_18

3. Connect the gray flexible cables to the A28 mixer in the order shown in [Figure 4](#). The other ends of the cables will be connected when the IF board is reinstalled later.

**Figure 4 A28 Mixer Brick Cable Installation**

① Install Cable N5242-60024,

③ Install Cable N5242-60020,

⑤ Torque SMA nuts to 10 in-lbs.  
Note: Orientation of Gray Cable  
SMA connector on **mixer brick**.

② Install Cable N5242-60019,

④ Install Cable N5242-60023,

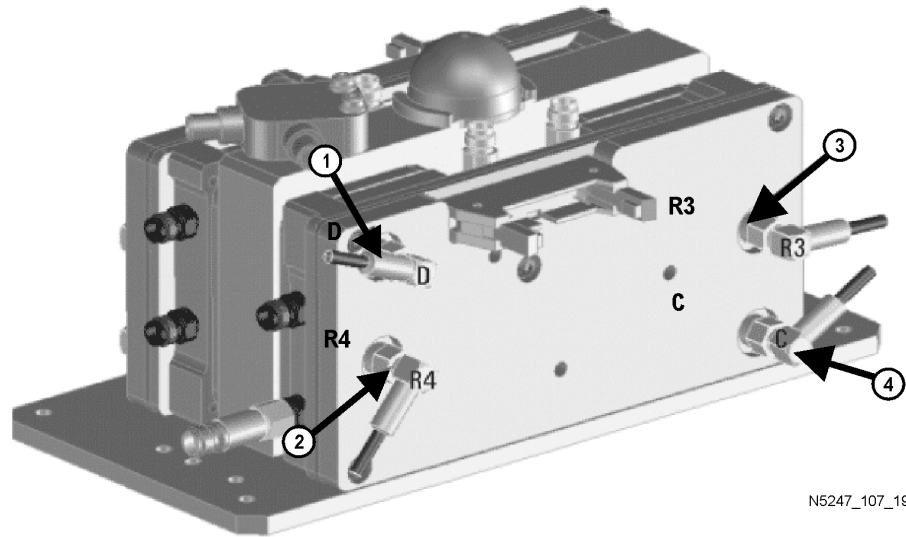

### Step 13. Install the A27/A28 Mixer Brick Assemblies

Reinstall the A27 mixer brick cables, and then install the A27/A28 mixer brick assembly, reusing the 10 existing screws. For instructions, click the Chapter 7 bookmark, “Removing and Replacing the A27 and A28 Mixer Bricks” in the PDF Service Guide<sup>1</sup>. New parts are listed in [Table 1 on page 7](#) of this document.

1. See “[Downloading the Online PNA Service Guide](#)” on page 5.

## Step 14. Assemble the Port 3 and Port 4 Attenuator Assemblies

Follow the instruction shown in [Figure 5](#). New parts are listed in [Table 1 on page 7](#) of this document

**Figure 5** Port 3 and Port 4 Attenuator Assemblies

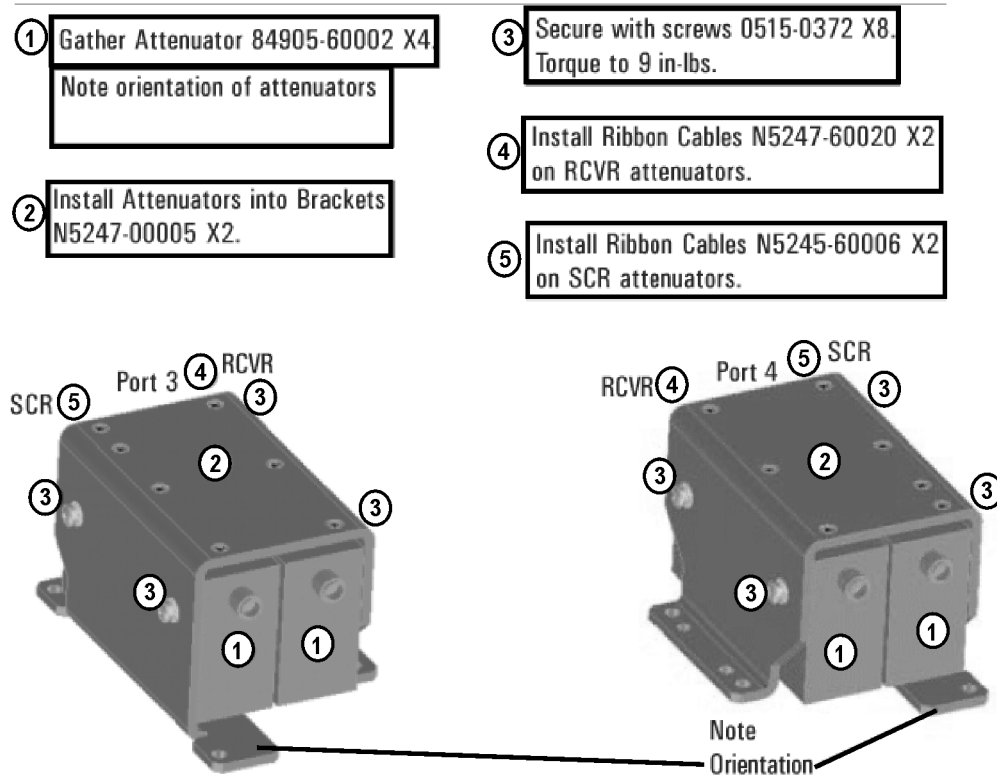

N5247\_107\_22

## Step 15. Install the Port 3 and Port 4 Attenuator Assemblies on the Test Set Deck

Install the Port 3 and Port 4 attenuator assemblies using four 0515-0372 screws to secure each bracket. For instructions, click the Chapter 7 bookmark, "Removing and Replacing the A38-A41 Source Attenuators and the A46-A49 Receiver Attenuators" in the PDF Service Guide<sup>1</sup>. New parts are listed in [Table 1 on page 7](#) of this document.

Refer to [Figure 8 on page 23](#) for the location of the attenuator assemblies.

## Step 16. Assemble the A30 and A31 Reference Coupler Assemblies

Follow the instructions shown in [Figure 6](#) and [Figure 7](#). New parts are listed in [Table 1 on page 7](#) of this document.

**Figure 6** A30 Reference Coupler Assembly

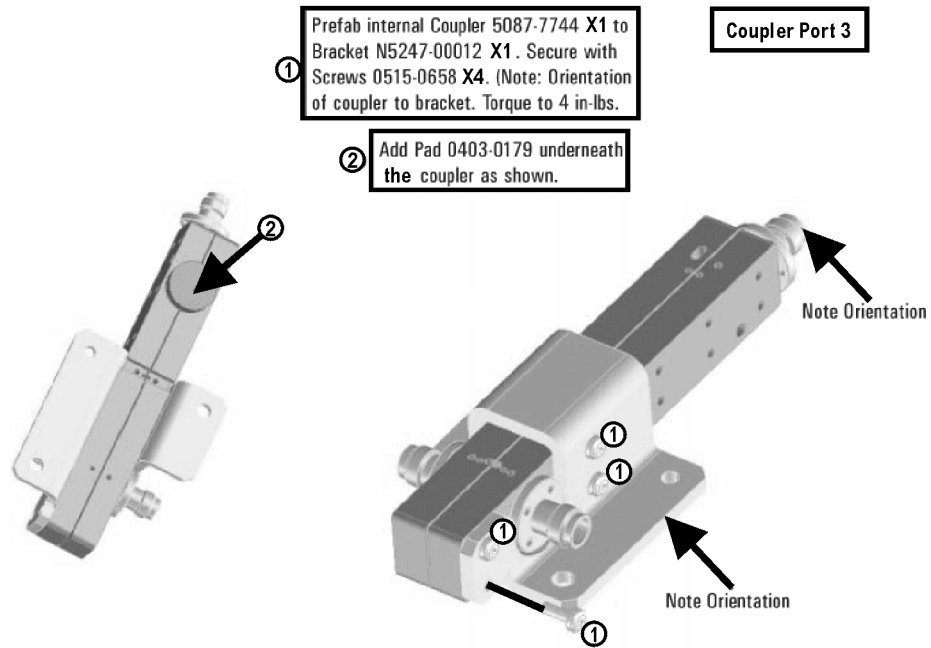

N5247\_107\_20

**Figure 7     A31 Reference Coupler Assembly**

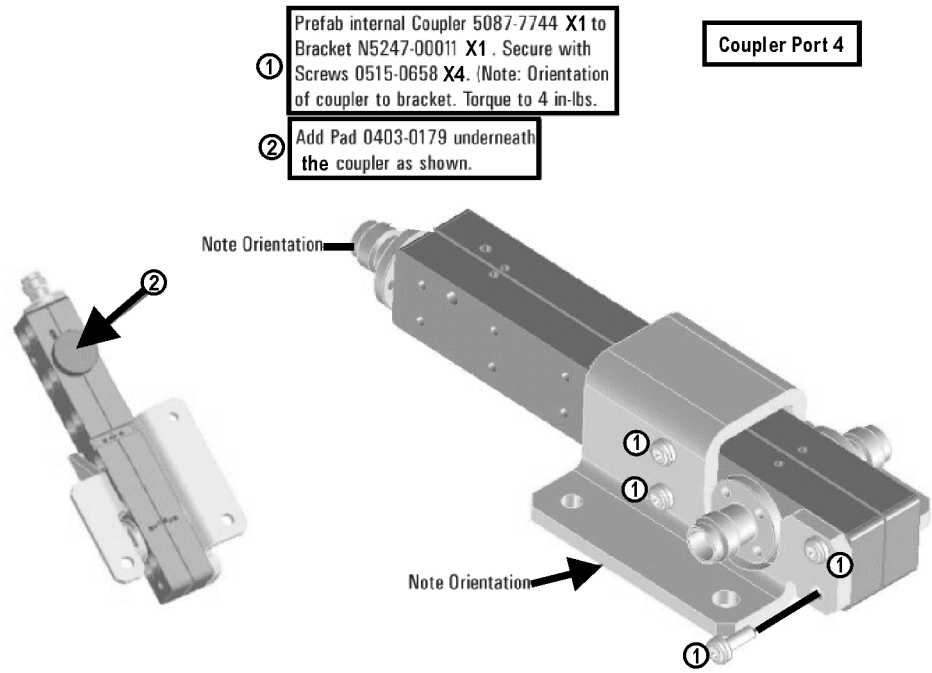

N5247\_107\_21

## Step 17. Install the A30 and A31 Reference Coupler Assemblies

Install the A30 and A31 reference coupler assemblies using three 0515-0372 screws to secure each bracket. For instructions, click the Chapter 7 bookmark, "Removing and Replacing the A29-A32 Reference Couplers and Reference Coupler Mounting Brackets" in the PDF Service Guide<sup>1</sup>. New parts are listed in [Table 1 on page 7](#) of this document.

Refer to [Figure 8](#) below for the location of the reference coupler assemblies.

**Figure 8** Location of Attenuator Assemblies and Reference Coupler Assemblies

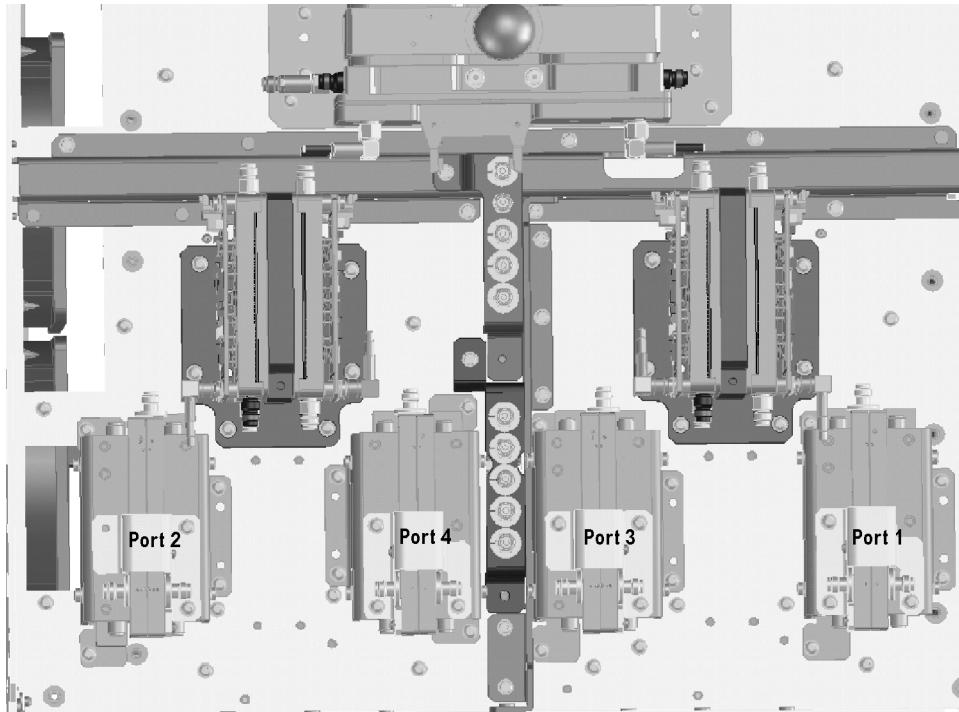

N5247\_106\_14

1. See ["Downloading the Online PNA Service Guide"](#) on page 5.



## Step 18. Relocate the A54 Combiner Assembly

1. Remove the A54 combiner/bracket assembly from the test set deck, leaving the A54 combiner connected to the bracket. Discard the three screws.
2. Follow the instruction in [Figure 9](#) to install the combiner assembly on top of the port 1 attenuator assembly bracket.

**Figure 9** Installing A54 Combiner/Bracket Assembly on Top of Port 1 Attenuator Assembly Bracket

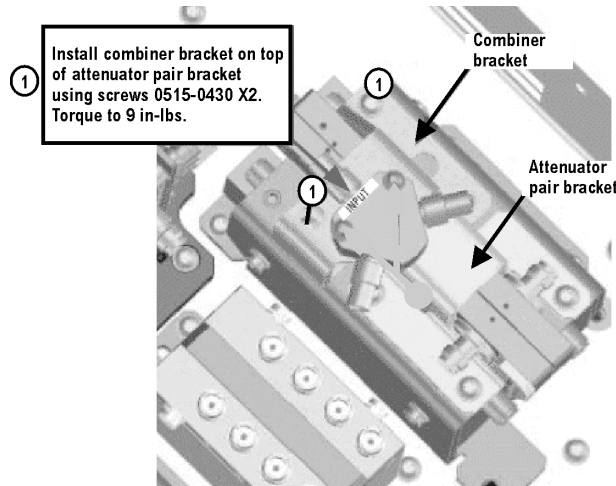

N5247\_107\_01

## Step 19. Remove the Bias Tee Blocks From the Test Set Deck

Remove the two bias tee blocks from the test set deck. For instructions, click the Chapter 7 bookmark, “Removing and Replacing the A42-A45 Bias Tees” in the PDF Service Guide<sup>1</sup>. Keep all parts for reinstallation later.

1. See [“Downloading the Online PNA Service Guide”](#) on page 5.

## Step 20. Install the A43 and A44 Bias Tees on the Bias Tee Blocks

Follow the instruction in [Figure 10](#) to install the A43 and A44 bias tees on the bias tee blocks. New parts are listed in [Table 1 on page 7](#) of this document.

**Figure 10** Installing A43 and A44 Bias Tees on the Bias Tee Blocks

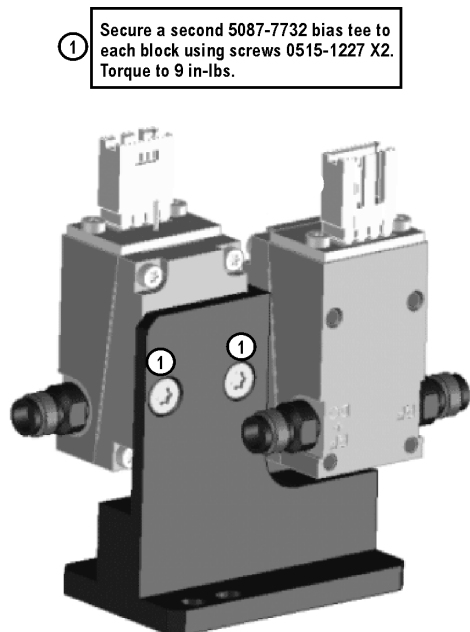

N5247\_107\_02

## Step 21. Reinstall the Bias Tee Blocks

Reinstall the two bias tee blocks on the test set deck, reusing the existing screws. For instructions, click the Chapter 7 bookmark, “Removing and Replacing the A42-A45 Bias Tees” in the PDF Service Guide<sup>1</sup>.

---

**NOTE** As shown in “Removing and Replacing the A42-A45 Bias Tees” in the PDF Service Guide, the slot on the bias tee block should be oriented toward the back of the PNA.

---

## Step 22. Remove the A53 Mechanical Switch/Bracket Assembly from the Test Set Deck

1. Remove the A53 mechanical switch/bracket assembly from the test set deck. For instructions, click the Chapter 7 bookmark, “Removing and Replacing the A50-A53 Bypass Switches and the A54 Combiner” in the PDF Service Guide<sup>1</sup>. Keep all parts for reinstallation later.

---

1. See “[Downloading the Online PNA Service Guide](#)” on page 5.

### Step 23. Install the A52 Mechanical Switch on the Bracket

Follow the instruction in [Figure 11](#) to install the A52 mechanical switch on the bracket. New parts are listed in [Table 1 on page 7](#) of this document.

**Figure 11** Installing the A52 Mechanical Switch on the Bracket

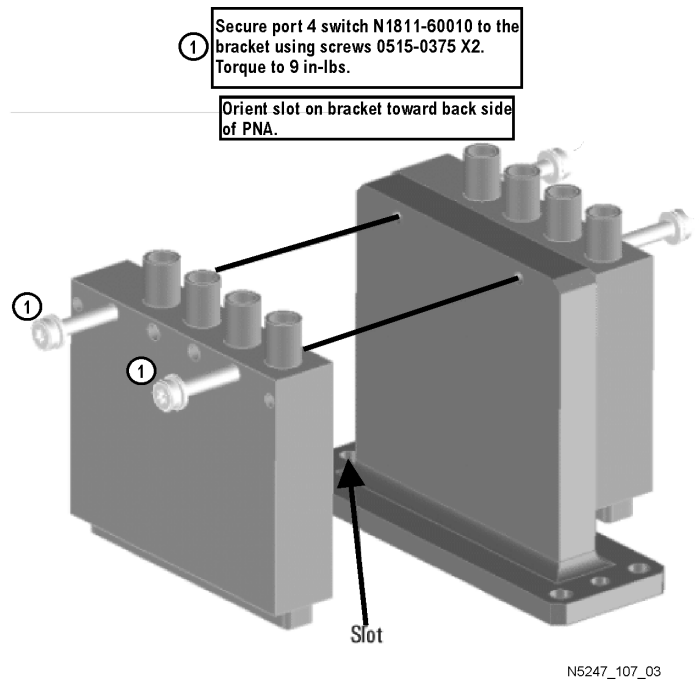

### Step 24. Reinstall the A52/A53 Mechanical Switch Assembly On the Test Set Deck

Reinstall the mechanical switch assembly on the test set deck, reusing the existing screws. For instructions, click the Chapter 7 bookmark, "Removing and Replacing the A50-A53 Bypass Switches and the A54 Combiner" in the PDF Service Guide<sup>1</sup>.

---

**NOTE** As shown in the graphic above, the slot on the mechanical switch bracket should be oriented toward the back of the PNA.

---

1. See ["Downloading the Online PNA Service Guide"](#) on page 5.

## Step 25. Assemble the A33 - A36 Test Port Coupler Assemblies

1. Remove the A33 test port 1 coupler and A36 test port 2 coupler from the PNA. For instructions, click the Chapter 7 bookmark, "Removing and Replacing the A33 - A36 Test Port Couplers" in the PDF Service Guide<sup>1</sup>.
2. Using pliers, remove the adhesive bumper on the A33 test port 1 coupler and on the A36 test port 2 coupler.
3. Follow the two instructions shown in [Figure 12](#). New parts are listed in [Table 1 on page 7](#) of this document.

**Figure 12** A33 - A36 Test Port Coupler Assembly

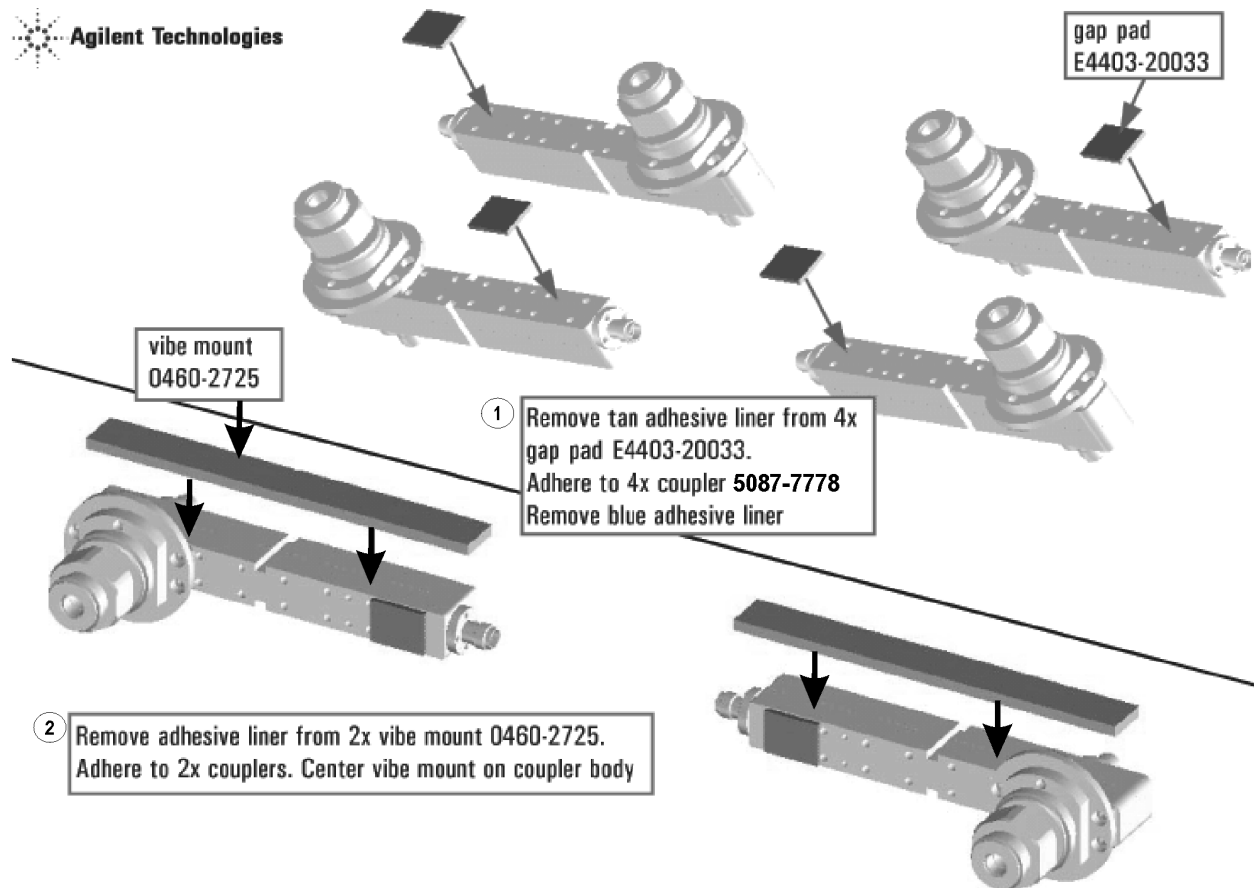

N5247\_107\_11

1. See "Downloading the Online PNA Service Guide" on page 5.

## Step 26. Remove and Disassemble the 2-Port Test Set Front Plate

1. Remove two screws from each LED board and remove the boards from the 2-port test set front plate of the PNA. Keep the screws for reinstallation later.
2. Remove the 2-port test set front plate from the test set deck. Keep the screws to reuse later.
3. Remove the 16 bulkhead connectors, nuts and washers from the 2-port front plate to reuse later.

## Step 27. Install the LED Boards, Bulkhead Connectors, and Test Port Coupler Assemblies to the 4-Port Test Set Front Plate

1. Follow the three instructions shown in [Figure 12-2](#).

**Figure 12-2 LED Board Assemblies and Test Port Coupler Assemblies Installation**

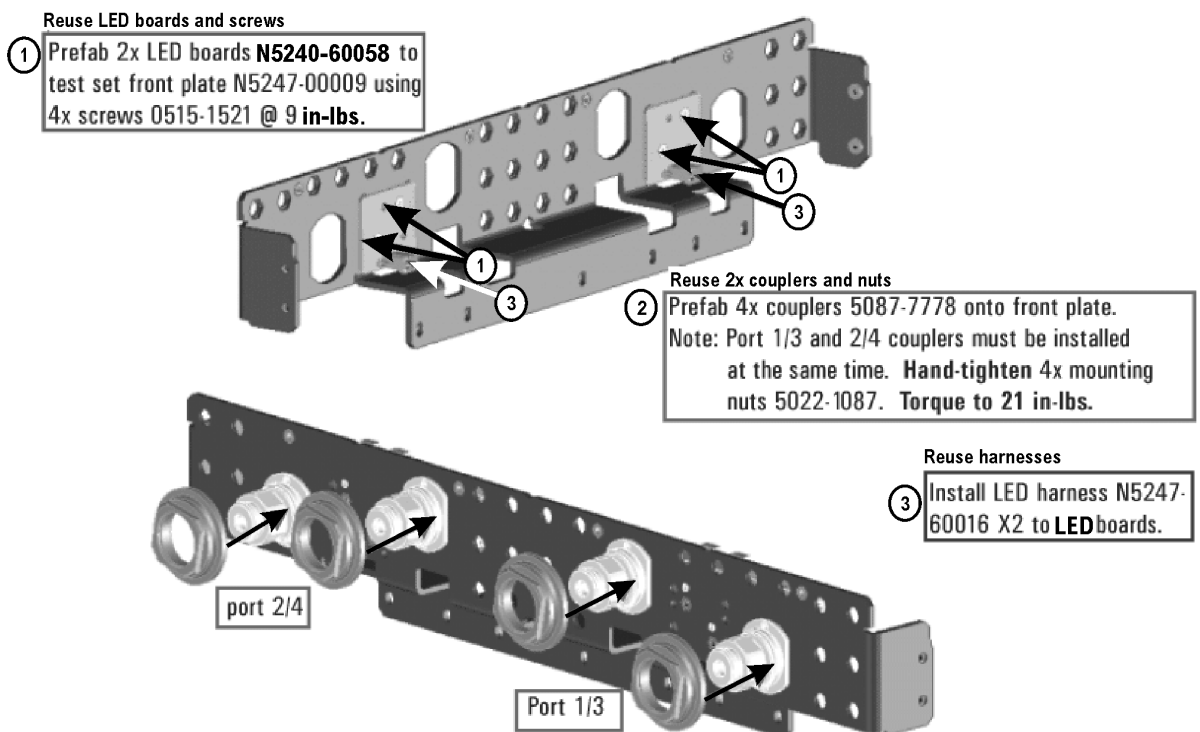

N5247\_107\_12

2. Reinstall the 16 bulkhead connectors, nuts and washers taken from the 2-port front plate into the 4-port front plate. Torque to 21 in-lbs.
3. Install 12 new bulkhead connectors, nuts and washers into the 4-port front plate. Torque to 21 in-lbs.

## Step 28. Install the 4-Port Coupler Plate Assembly to the Deck

Follow the three instructions shown in **Figure 13**.

**Figure 13** Coupler Plate Assembly Installation

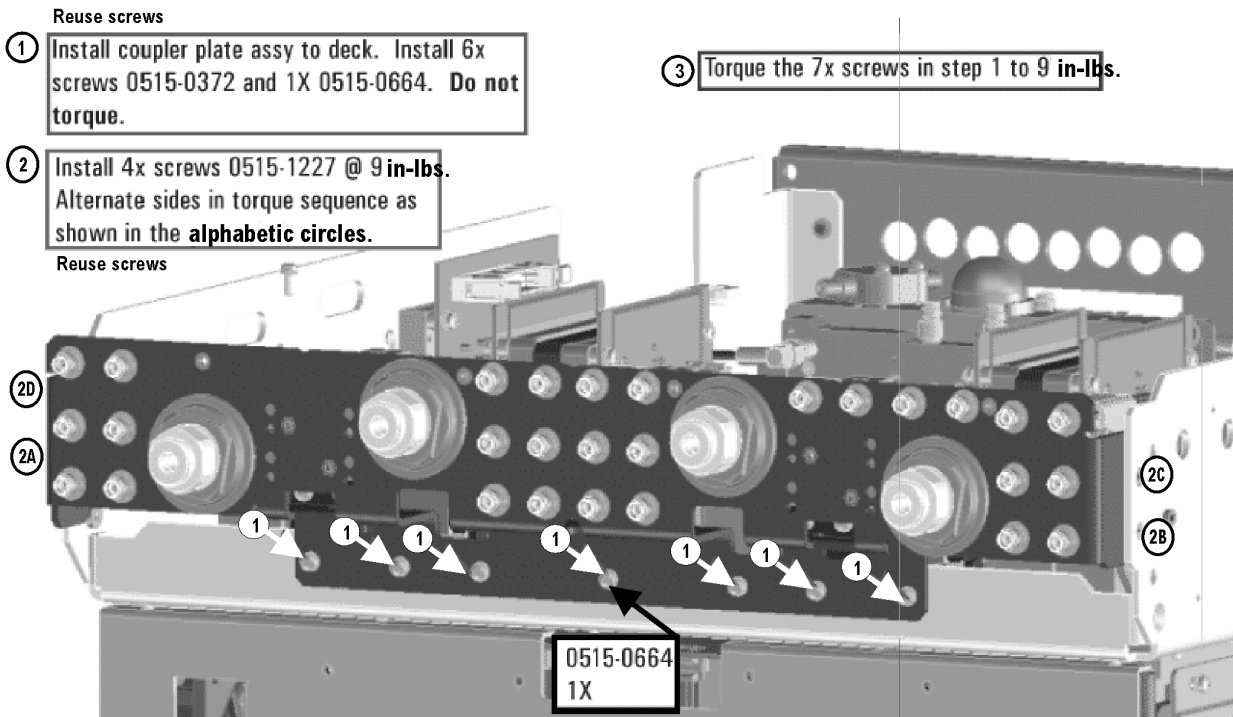

N5247\_107\_13

## Step 29. Install Some Bottom-Side (Test Set) Cables

---

**CAUTION** Use a 5/16-in torque wrench set to 10 in-lbs on all cable connections except the front and rear panel cable connectors. Torque these connections to 21 in-lb.

---

**CAUTION** Be careful not to damage the center pins of the semirigid cables. Some flexing of the cables may be necessary but do not over-bend them.

---

### Semirigid Cables Required for Upgrading to an Option 423 PNA

Install the following semirigid cables in the order listed. To see images showing the location of these cables, click the Chapter 6 bookmark “Bottom RF Cables, 4-Port, Option 423” in the PDF Service Guide<sup>1</sup>. New parts are listed in [Table 1 on page 7](#).

- W115 (reuse) (N5247-20027) A45 port 2 bias tee to port 2 CPLR THRU
- W116 (N5247-20080) A45 port 2 bias tee to A36 port 2 coupler
- W112 (N5247-20029) A44 port 4 bias tee to A35 port 4 coupler
- W111 (N5247-20021) A44 port 4 bias tee to port 4 CPLR THRU
- W104 (N5247-20022) A42 port 1 bias tee to A33 port 1 coupler
- W103 (N5247-20081) A42 port 1 bias tee to port 1 CPLR THRU
- W107 (reuse) (N5247-20010) A43 port 3 bias tee to port 3 CPLR THRU
- W108 (N5247-20028) A43 port 3 bias tee to A34 port 3 coupler
- W142 (reuse) (N5247-20089) A53 port 2 mechanical switch to PORT 2 TSET IN (J1)
- W138 (N5247-20098) A52 port 4 mechanical switch to PORT 4 SW TSET (J3)
- W137 (N5247-20097) A52 port 4 mechanical switch to PORT 4 SW SRC OUT (J4)

\* Install clamp part number 1400-1334 to secure W137 and W138. Position it next to the existing clamp that secures W141 and W142.

- W46 (N5247-20019) A36 port 2 coupler to port 2 CPLR ARM
- W123 (reuse) (N5247-20020) A49 port 2 receiver attenuator to port 2 RCVR B IN
- W114 (reuse) (N5247-20034) A41 port 2 source attenuator to port 2 SOURCE OUT
- W146 (reuse) (N5247-20058) A32 port 2 reference coupler to REF 2 SOURCE OUT
- W145 (N5247-20066) A27 mixer brick (R2) to REF 2 RCVR R2 IN

\* As shown in [Figure 14](#), install clamp part number 1400-1334 to secure W145.

**Figure 14** Location of W145 and W146 Cables and Securing Clamps

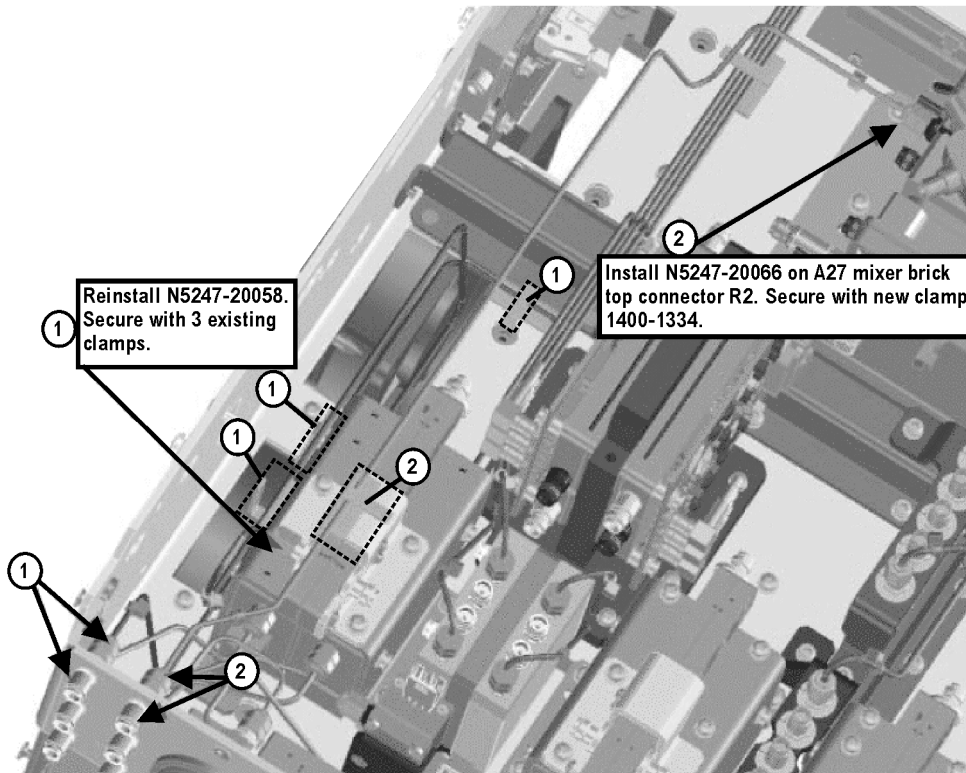

N5247\_107\_04

- W121 (N5247-20024) A48 port 4 receiver attenuator to port 4 RCVR D IN
- W42 (N5247-20026) A35 port 4 coupler to port 4 CPLR ARM
- W110 (N5247-20025) A40 port 4 source attenuator to port 4 SOURCE OUT
- W41 (N5247-20069) A31 port 4 reference coupler to REF 4 SOURCE OUT
- W55 (N5247-20067) A28 mixer brick (R4) to REF 4 RCVR R4 IN

\* As shown in **Figure 15**, install clamp part number 1400-1334 to secure W41, and install cable tie part number 1400-0249 to secure W55.



**Figure 15** Location of Cable Clamp to Secure W41 and Cable Tie to Secure W55



N5247\_107\_05

- W119 (N5247-20008) Port 3 RCVR C IN to A47 port 3 receiver attenuator
- W38 (N5247-20007) Port 3 CPLR ARM to A34 port 3 coupler
- W106 (N5247-20009) Port 3 SOURCE OUT to A39 port 3 source attenuator
- W37 (N5247-20070) A30 port 3 reference coupler to front panel REF 3 SOURCE OUT
- W54 (N5247-20062) REF 3 RECEIVER R3 IN to A28 mixer brick (R3)

\* As shown in **Figure 16**, install clamp part number 1400-1334 to secure W37, and install two cable ties, part number 1400-0249, to secure W37 and W54.

**Figure 16** Location of Cable Clamp to Secure W37 and Cable Ties to Secure W37/W54

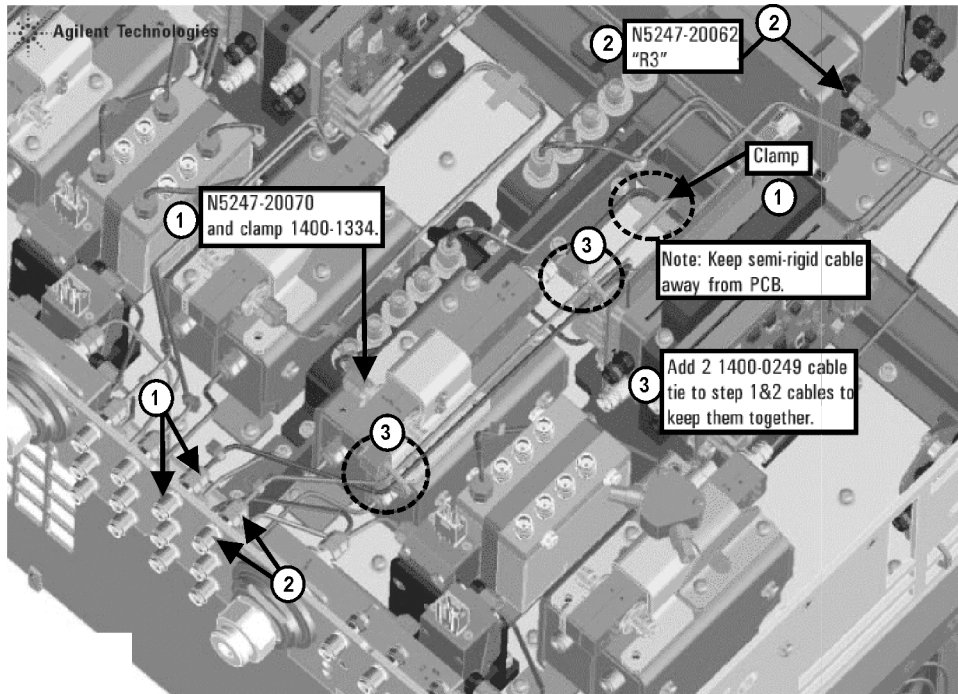

N5247\_107\_06

- W117 (reuse) (N5247-20013) A46 port 1 receiver attenuator to port 1 RCVR A IN
- W34 (N5247-20082) A33 port 1 coupler to port 1 CPLR ARM
- W102 (reuse) (N5247-20014) A38 port 1 source attenuator to port 1 SOURCE OUT
- W144 (N5247-20071) A29 port 1 reference coupler to A37 reference mixer switch

\* As shown in **Figure 17**, install cable tie, part number 1400-0249, to secure W144.

**Figure 17**    **Location of Cable Ties to Secure W144**

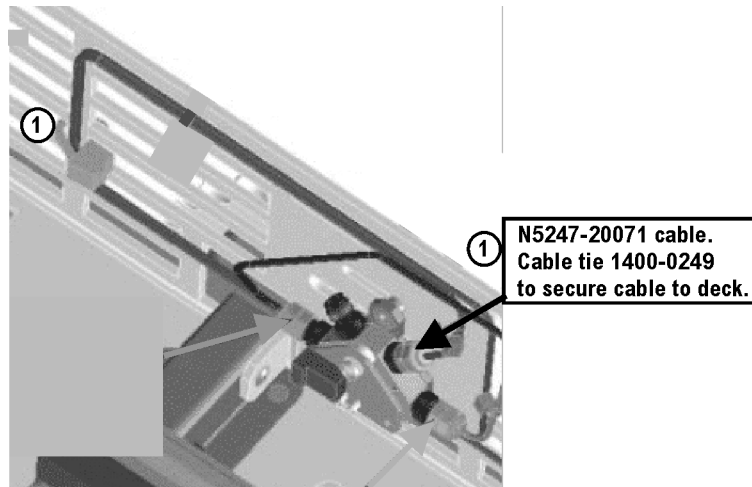

N5247\_107\_07

- W51 (reuse) (N5247-20011) A37 reference mixer switch to REF 1 SOURCE OUT
- W52 (reuse) (N5247-20012) A37 reference mixer switch to REF 1 RCVR R1 IN
- W53 (reuse) (N5247-20048) A37 reference mixer switch to A27 mixer brick (R1)
- W120 (N5247-20064) A47 port 3 receiver attenuator to A28 mixer brick (C)
- W118 (reuse) (N5247-20047) A46 port 1 receiver attenuator to A27 mixer brick (A)
- W140 (reuse) (N5247-20033) A53 port 2 mechanical switch to A32 port 2 reference coupler
- W132 (N5247-20033) A51 port 3 mechanical switch to A30 port 3 reference coupler
- W136 (N5247-20031) A52 port 4 mechanical switch to A31 port 4 reference coupler
- W126 (reuse) (N5247-20031) A50 port 1 mechanical switch to A29 port 1 reference coupler
- W101 (reuse) (N5247-20083) A29 port 1 reference coupler to A38 port 1 source attenuator
- W113 (reuse) (N5247-20083) A32 port 2 reference coupler to A41 port 2 source attenuator
- W105 (N5247-20083) A30 port 3 ref coupler to A39 port 3 source attenuator
- W109 (N5247-20083) A31 port 4 ref coupler to A40 port 4 source attenuator
- W22 (reuse) (N5247-20068) A62 port 4 70 GHz doubler to W21
- W26 (reuse) (N5247-20051) A63 port 2 70 GHz doubler to W25
- W24 (reuse) (N5247-20061) A63 port 2 70 GHz doubler to W23
- W122 (N5247-20065) A48 port 4 receiver attenuator to A28 mixer brick (D)
- W124 (reuse) (N5247-20046) A49 port 2 receiver attenuator to A27 mixer brick (B)
- W18 (reuse) (N5247-20084) A61 port 3 70 GHz doubler to W17
- W14 (reuse) (N5247-20072) A60 port 1 70 GHz doubler to W13
- W16 (reuse) (N5247-20060) A61 port 3 70 GHz doubler to W15

- W125 (reuse) (N5247-20030) A50 port 1 mechanical switch to A60 port 1 70 GHz doubler
- W135 (N5247-20030) A52 port 4 mechanical switch to A62 port 4 70 GHz doubler
- W12 (reuse) (N5247-20059) A60 port 1 70 GHz doubler to W11
- W139 (reuse) (N5247-20032) A53 port 2 mechanical switch to A63 port 2 70 GHz doubler
- W131 (reuse) (N5247-20032) A51 port 3 mechanical switch to A61 port 3 70 GHz doubler
- W20 (reuse) (N5247-20015) A62 port 4 70 GHz doubler to W19
- W133 (N5247-20090) A51 port 3 mechanical switch to front panel PORT 3 SW SRC OUT
- W130 (N5247-20094) A50 port 1 mechanical switch to A54 combiner
- W127 (N5247-20091) A50 port 1 mechanical switch to front panel PORT 1 SW SRC OUT
- W129 (N5247-20093) A54 combiner to front panel PORT 3 COMB ARM IN
- W128 (N5247-20092) A54 combiner to front panel PORT 1 COMB THRU IN
- W64 (N5245-20022) A26 splitter to A28 mixer brick
- W63 (N5245-20023) A26 splitter to A27 mixer brick
- W62 (N5247-20111) A26 splitter to A25 HMA26.5
  - \* Tighten the screws that secure the A26 splitter to the mixer mounting block.
- W58 (N5247-20138) 2.4 mm cap for A28 mixer brick

### Step 30. Reinstall the A24 IF Multiplexer Board

For instructions, click the Chapter 7 bookmark “Removing and Replacing the A24 IF Multiplexer Board” in the PDF Service Guide<sup>1</sup>.

### Step 31. Install Cables on IF Multiplexer Board

Install the following gray flexible cables in the order listed. Mixer brick cables were connected to the mixer bricks earlier in this procedure, but the other ends of these cables still require a connection. To see images showing the location of these cables, click either of the Chapter 6 bookmarks “Bottom RF Cables, 4-Port, Option 423” in the PDF Service Guide<sup>1</sup>. New parts are listed in [Table 1 on page 7](#).

- W80 (N5242-60013) A24 IF multiplexer board P203 to A16 SPAM board J2
- W82 (N5242-60015) A24 IF multiplexer board P603 to A16 SPAM board J5
- W71 (reuse) (N5242-60017) A27 mixer brick (A) to A24 IF multiplexer (P1)
- W72 (N5242-60021) A27 mixer brick (R1) to A24 IF multiplexer (P411)
- W73 (N5242-60022) A27 mixer brick (R2) to A24 IF multiplexer (P412)
- W74 (reuse) (N5242-60018) A27 mixer brick (B) to A24 IF multiplexer (P201)
- W75 (N5242-60024) A28 mixer brick (D) to A24 IF multiplexer (P801)

1. See [“Downloading the Online PNA Service Guide” on page 5](#).

- W76 (N5242-60019) A28 mixer brick (R4) to A24 IF multiplexer (P414)
- W77 (N5242-60020) A28 mixer brick (R3) to A24 IF multiplexer (P413)
- W78 (N5242-60023) A28 mixer brick (C) to A24 IF multiplexer (P601)
- W79 (reuse) (N5242-60012) A24 IF multiplexer board P3 to A16 SPAM board J1
- W81 (reuse) (N5242-60014) A24 IF multiplexer board P403 to A16 SPAM board J4
- W83 (reuse) (N5242-60016) A24 IF multiplexer board P803 to A16 SPAM board J6

### Step 32. Reinstall the A23 Test Set Motherboard

1. For instructions on reinstalling the board, click the Chapter 7 bookmark “Removing and Replacing the A23 test set motherboard” in the PDF Service Guide<sup>1</sup>.

### Step 33. Install Cables on the A23 Test Set Motherboard

---

**CAUTION** Follow instructions carefully when making cable connections, especially wire harness connections. Incorrect connections can destroy components, resulting in additional customer costs.

---

If not already done in a previous step, install the following new ribbon cables and wire harness in the order listed. To see an image showing their locations, click the Chapter 6 bookmark “Bottom Ribbon Cables and Wire Harnesses, 4-Port, Option 423” in the PDF Service Guide<sup>1</sup>. New parts are listed in [Table 1 on page 7](#).

- Ribbon cable (N5247-60015) from A23 test set motherboard J552 to A28 mixer brick (2) J52
- Ribbon cable (N5247-60021), port 3 bias tee to A23 test set motherboard J543
- Ribbon cable (N5247-60021), port 4 bias tee to A23 test set motherboard J544
- Ribbon cable (N5247-60020), A23 test set motherboard J206 to A47 port 3 receiver attenuator
- Ribbon cable (N5247-60020), A23 test set motherboard J207 to A48 port 4 receiver attenuator
- Ribbon cable (N5245-60006), A23 test set motherboard J547 to A39 port 3 source attenuator
- Ribbon cable (N5245-60006), A23 test set motherboard J548 to A40 port 4 source attenuator
- Wire harness (part of mechanical switch assembly), A23 test set motherboard J103 to A52 port 4 mechanical switch

---

1. See [“Downloading the Online PNA Service Guide” on page 5](#).

### Step 34. Install the Braces on the Bottom Side of the PNA

Follow the three instructions shown in [Figure 18](#).

**Figure 18** Location of Braces on the Bottom Side of the PNA

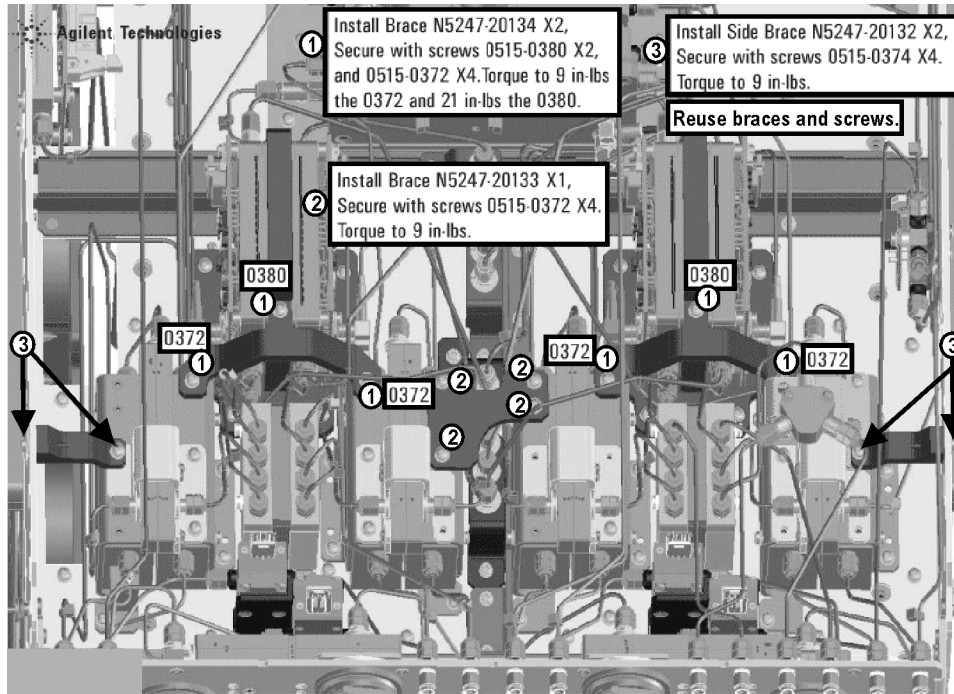

N5247\_107\_08

### Step 35. Replace the Front Frame in the Front Panel Assembly

Before the front frame can be replaced, the items making up the back side of the front panel assembly must be removed. For instructions on removing these items, click the Chapter 7 bookmark “Removing and Replacing the A1-A3 and Other Front Panel Subassemblies” in the PDF Service Guide<sup>1</sup>. New parts are listed in [Table 1 on page 7](#).

1. In the section “Removing the A2 USB Board,” perform the only step.
2. In the section “Removing the A1 Front Panel Interface Board and Keypad Assembly,” perform steps 1 - 5.
3. In the section “Removing the Power Switch Board and Power Button Keypad,” perform only step 1.
4. Remove the braided gasket from the backside edges of the 2-port front frame and install it in the 4-port front frame.
5. Reassemble the front panel assembly with the new 4-port front frame (N5247-20141) by reversing the order of the instructions previously followed.

### Step 36. Reinstall Front Panel Assembly

For instructions on reinstalling the front panel assembly, click the Chapter 7 bookmark “Removing and Replacing the Front Panel Assembly” in the PDF Service Guide<sup>1</sup>.

### **Step 37. Install the Overlays and Nameplate**

To see an image of the front panel overlay (N5247-80002), keypad overlay (N5242-80005), power button overlay (N5242-80007), and nameplate (N5247-80006), click the Chapter 6 bookmark “Front Panel Assembly, Front Side, All Options” in the PDF Service Guide<sup>1</sup>. New parts are listed in [Table 1 on page 7](#).

1. Remove the protective backing from the new front panel overlay (N5247-80002).
2. Loosely place the overlay in the recess on the lower front panel.
3. Placing two fingers at the middle, press the overlay firmly onto the frame while sliding your fingers in opposite directions towards the ends of the overlay. Repeat on all areas of the overlay.
4. Repeat steps 1-3 to install the keypad overlay (N5242-80005).
5. Repeat steps 1-3 to install the power button overlay (N5242-80007).
6. Install the new nameplate (N5247-80006).

### **Step 38. Install the Jumper Cables**

1. Install fourteen W60 front panel jumper cables (N5247-20107) - use 8 new jumpers and reuse 6 old jumpers. To see an image of the front panel jumper cables, click the Chapter 7 bookmark “Removing and Replacing the Front Panel Assembly” in the PDF Service Guide<sup>1</sup>.
2. Install new W143 rear panel jumper cable (N5247-20107) from SW SRC OUT (J4) to SW TSET IN (J3). To see an image showing the location of this rear panel jumper, click on the Chapter 6 bookmark “Rear Panel Assembly, All Options” in the PDF Service Guide<sup>1</sup>.

### **Step 39. Position the Cables and Wires to Prevent Pinching**

On the top side of the PNA, carefully position the grey flex cables so they can't be pinched between the covers and the rails.

On the bottom side of the PNA, carefully fold or push down the ribbon cables and wires so they can't be pinched between the hardware and the outer cover. Ribbon cables and wires must never be positioned on top of hardware.

### **Step 40. Reinstall the Inner Cover**

For instructions, click the Chapter 7 bookmark “Removing the Covers” in the PDF Service Guide<sup>1</sup>.

### **Step 41. Reinstall the Outer Cover**

For instructions, click the Chapter 7 bookmark “Removing the Covers” in the PDF Service Guide<sup>1</sup>.

---

1. See [“Downloading the Online PNA Service Guide” on page 5](#).

## Step 42. Remove Option 224 and Option 219 Licenses

### Procedure Requirements

- The analyzer must be powered up and operating to perform this procedure.
- The Network Analyzer program must be running.
- A keyboard and mouse must be connected to the network analyzer.

### Option 224 and Option 219 License Removal Procedure

1. To start the option enable utility, press UTILITY **System** , then **Service** , then **Option Enable** . An option enable dialog box will appear.
2. Click the arrow in the **Select Desired Option** box. A list of available options will appear.
3. In the **Select Desired Option** list, click **224**.
4. Click **Remove**.
5. Click **OK** to confirm that you want to remove the license for the selected option.
6. Click **No** in answer to the displayed question in the **Restart Analyzer?** box.
7. Click the arrow in the **Select Desired Option** box. A list of available options will appear.
8. In the **Select Desired Option** list, click **219**.
9. Click **Remove**.
10. Click **OK** to confirm that you want to remove the license for the selected option.
11. Click **Yes** in answer to the displayed question in the **Restart Analyzer?** box.



## Step 43. Enable Options P04 (400), 419, and 423

### Procedure Requirements

- The analyzer must be powered up and operating to perform this procedure.
- The Network Analyzer program must be running.
- A keyboard and mouse must be connected to the network analyzer.

### Option Enable Procedure

1. To start the option enable utility, press UTILITY **System**, then **Service**, then **Option Enable**. An option enable dialog box will appear.
2. Click the arrow in the **Select Desired Option** box. A list of available options will appear.
3. In the **Select Desired Option** list, click **P04 - 4-Ports**.
4. Using the keyboard, enter the license key in the box provided. The license key is printed on the the license message you received from Keysight. Enter this key *exactly* as it is printed on the message.
5. Click **Enable**.
6. Click **Yes** in answer to the displayed question in the **Restart Analyzer?** box.
7. Repeat steps 3-6 to enable Option 419, clicking **419 - Src/Rcvr Atten & Bias Ts 4-Port** in step 3.
8. Repeat steps 3-6 to enable Option 423, clicking **423 - Combiner & Switches** in step 3.
9. When the installation is complete, click **Exit**.

### Option Verification Procedure

Once the analyzer has restarted and the Network Analyzer program is again running:

1. On the analyzer's **Help** menu, click **About Network Analyzer**.
2. Verify that "P04," "419," and "423" are listed, but "224" and "219" are not listed after "Options:" in the display. Click **OK**.

---

**NOTE** If the options have not been enabled or if the option 224 and option 219 licenses have not been removed, perform the prior steps again. If the options are still not correct, contact Keysight Technologies. Refer to ["Getting Assistance from Keysight" on page 3](#).

---

## Step 44. Perform Post-Upgrade Adjustments and Calibration

### Adjustments

The following adjustments must be made due to the hardware changes of the analyzer.

- source adjustment
- receiver adjustment
- receiver characterization

These adjustments are described in the PNA Service Guide and in the PNA on-line HELP. A list of equipment required to perform these adjustments is also found in the service guide.

After the specified adjustments have been performed, the analyzer should operate and phase lock over its entire frequency range.

### Operator's Check

Perform the Operator's Check to check the basic functionality of the analyzer. For instructions, click the Chapter 3 bookmark "Tests and Adjustments" in the PDF Service Guide<sup>1</sup>.

If you experience difficulty with the basic functioning of the analyzer, contact Keysight. Refer to ["Contacting Keysight" on page 3](#).

### Calibration

Although the analyzer functions, its performance relative to its specifications has not been verified. It is recommended that a full instrument calibration be performed using the analyzer's internal performance test software. To view information on the performance test software, click the Chapter 3 bookmark "Tests and Adjustments" in the PDF Service Guide<sup>1</sup>.

## Step 45. Prepare the PNA for the User

1. If necessary, reinstall front jumper cables.
2. Install the cable guards, pushing them over the front jumper cables until the cushioning material touches the front panel of the PNA.
3. Install the dust caps on the test ports.
4. Clean the analyzer, as needed, using a damp cloth.

---

1. See ["Downloading the Online PNA Service Guide" on page 5](#).



This information is subject to change without notice.

© Keysight Technologies 2013 - 2014

November 2014



N5247-90107  
[www.keysight.com](http://www.keysight.com)