

Agilent N5978A IFT Automation for TD-LTE IOT Test Plan

Technical Overview

Accelerate testing and reporting to TD-LTE IOT Test Plan

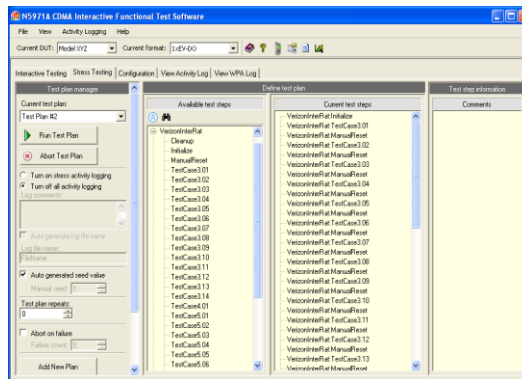

Device Compliance Test Results			
Product Feature	Requirement	Test Case	Result
E-UTRAN	E-UTRAN	CELL_SELECTION_CNR_10	Step 0: PASSED
		CELL_SELECTION_CNR_10	Step 1: PASSED
		CELL_SELECTION_CNR_10	Step 2: PASSED
		CELL_SELECTION_CNR_10	Step 3: PASSED
		CELL_SELECTION_CNR_10	Step 4: PASSED
		CELL_SELECTION_CNR_10	Step 5: PASSED
E-UTRAN	E-UTRAN	CELL_SELECTION_CNR_10	Step 6: PASSED
		CELL_SELECTION_CNR_10	Step 7: PASSED
		CELL_SELECTION_CNR_10	Step 8: PASSED
		CELL_SELECTION_CNR_10	Step 9: PASSED
		CELL_SELECTION_CNR_10	Step 10: PASSED
		CELL_SELECTION_CNR_10	Step 11: PASSED
E-UTRAN	E-UTRAN	CELL_SELECTION_CNR_10	Step 12: PASSED
		CELL_SELECTION_CNR_10	Step 13: PASSED
		CELL_SELECTION_CNR_10	Step 14: PASSED
		CELL_SELECTION_CNR_10	Step 15: PASSED
		CELL_SELECTION_CNR_10	Step 16: PASSED
		CELL_SELECTION_CNR_10	Step 17: PASSED
E-UTRAN	E-UTRAN	CELL_SELECTION_CNR_10	Step 18: PASSED
		CELL_SELECTION_CNR_10	Step 19: PASSED
		CELL_SELECTION_CNR_10	Step 20: PASSED
		CELL_SELECTION_CNR_10	Step 21: PASSED
		CELL_SELECTION_CNR_10	Step 22: PASSED
		CELL_SELECTION_CNR_10	Step 23: PASSED

TD Devices with four technologies: GSM, TD-SCDMA, LTE FDD and LTE TDD will co-exist for the foreseeable future. For a positive end-user experience, UE needs to transition smoothly between these technologies while in the same time maintain acceptable performance for different applications. While conformance test is necessary, it is not sufficient to determine the user experience under different circumstances. As a result, developers and operators are increasing their focus on testing the real-world performance of UE before deploying them on live networks.

The new Agilent N5978A automation scripts implement TD-LTE IOT Test Plan in Agilent's interactive functional test (IFT) software. Used in conjunction with Agilent PXT wireless communications test sets, the solution brings real-world network test scenarios into the lab environment.

Simplify Your Compliance Test Process

- **Leading TD-LTE IOT test coverage with ready-to-use test plans and reporting**
- **Unattended test with fully-automated execution and UE control**
- **Builds on Agilent IFT software and is expandable to other test plans**

Anticipate increasing UE performance demands

Network operators are motivated to ensure that performance of UE on their network results in a positive end-user experience. While signaling conformance test addresses certain aspects of functionality, operators typically want to conduct more representative performance testing under different network conditions. Examples include verifying the mobility, data throughput performance and power consumption of the UE as showed below. These real-world use scenarios supplement traditional conformance test and commonly formalized into operator-specific test plans, requiring UE be subjected to demanding compliance testing before being approved for use on an operator’s network.

Mobility:

Today, most TD-LTE devices are four modes: GSM, TD-SCDMA, LTE FDD and LTE TDD or even five modes: GSM, WCDMA, TD-SCDMA, LTE FDD and LTE TDD. Mobility test is required to verify the UE behaves as expected when transition between different radio access technologies. Mobility test includes cell selection/reselection, intra-LTE mobility, inter-RAT mobility and roaming test. The E5515C wireless test set is required when 2G or 3G cells are involved during the mobility test.

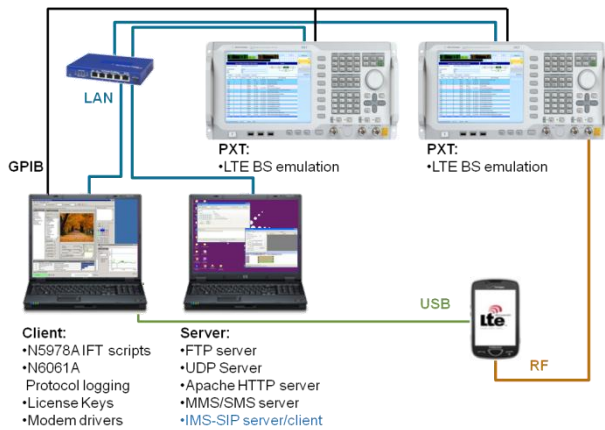

Figure 1. Schematic showing Agilent test implementation of Mobility test plan

Data Throughput:

Customers have higher expectations and are more aware of the data performance of their wireless devices in the LTE era. Data throughput test verifies the actual end-user experience under different channel configurations and radio conditions, help to address the data performance issue in early stage.

N9020A MXA Signal Analyzer, N5182 MXG Signal Source and N5106A PXB Baseband Generator and Channel Emulator are required to emulate the real-world

impairments. Actually, you can replace those three test instruments with an RF fader as well.

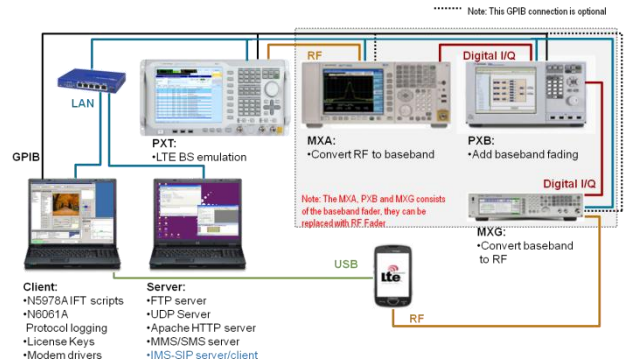

Figure 2. Schematic showing Agilent test implementation of Data Throughput test plan, SISO

Power Consumption:

End-user are frustrated with the short battery life of their smartphones and wireless data devices during real-world operation, making battery drain a top issue for wireless device designers and service providers. Operators are pushing for extended battery life not only for consumer satisfaction, but also so users can consume more pay-for-use data services – a critical revenue stream. Power consumption test verifies the power consumption of the UE under different channel configurations and application types.

N6705B DC Power Analyzer is required to measure the power consumption of the UE.

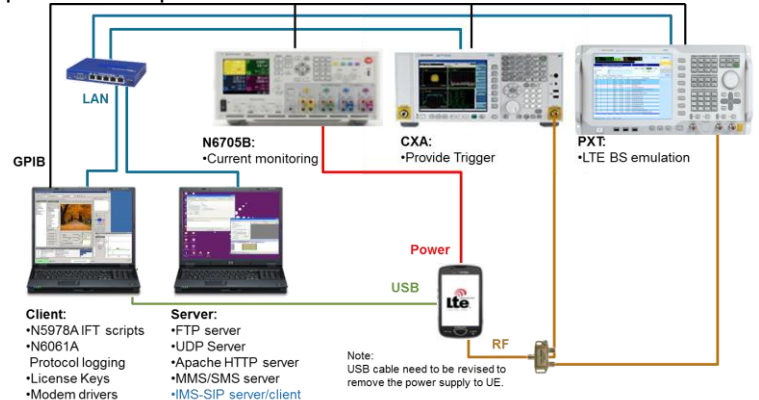

Figure 3. Schematic showing Agilent test implementation of Power Consumption test plan

Accelerate design and verification test cycles

Agilent has developed a number of test scripts based on TD-LTE IOT test requirements, including mobility, data throughput and power consumption test. Our measurement knowledge and experience of testing is built in to the pre-defined test cases, so you do not have to deal with the

complexity associated with test development, instrument control, and data management.

Our test environment allows you to create your own test plans in a drag-and-drop environment. You can run tests unattended and progress rapidly to deployment, providing reliable, repeatable measurements and automatically generating measurement reports to an easy-to-read format.

Achieve compliance testing to operator's test plan

The Agilent N5978A-1FP IFT scripts for TD-LTE IOT Test operations allow you to focus on testing the TD-LTE terminal performance without having to create complex code or program test equipment. Developed specifically for engineers engaged in design verification of TD-LTE UE for use on operator networks, this solution supplements your TD-LTE IOT testing expertise with Agilent experience and measurement knowledge, providing automated test scripts based on the operator test plan.

Efficiently test and report results

- **Drag-and-drop environment for sequencing pre-defined test cases into test plans**
- **Customizable UE control**
- **Generated results reported to an easy-to-read format**

Support for Agilent's established 8960 and PXT test sets

TD-LTE base station emulation is achieved using Agilent PXT wireless communication test sets. Already established in the world of 4G performance and conformance test, the leading test sets now support both IPv4 and IPv6 addressing, neighbor cell advertisement, and the required security configuration to implement the TD-LTE IOT test plan. The PXT includes an emulation of the evolved packet core (EPC)—an all-IP mobile core network required by 3GPP in Release 8 of the standards for LTE.

Get ahead faster

Agilent provides start-up assistance services to help you learn and harness the power of the N5978A software products. One day of start-up assistance is mandatory for first time purchase of the N5978A. Additional days of start-up assistance or productivity assistance can be ordered, if required.

Keep your test plans productive and current

Software and technical support contracts (STSC) entitle you to software updates and feature enhancements, as well as direct access to technical experts. These contracts are designed to increase your productivity by delivering software updates and providing a formal technical support channel for any operational difficulties you may encounter.

Our technical support engineers are experts on the N5978A test plans and related hardware. They have instant access to software and test sets enabling them to resolve your issues quickly. Agilent will investigate all software defects and operational problems reported through the technical support channel. Upon completion of the investigation, we will advise you of possible solutions, functional alternatives etc. Where possible, Agilent will provide software releases to address problems caused by defects in the software.

The N5978AS STSC covers all automation scripts you have purchased for the N5978A and also provides you with updates to the related IFT and IMS-SIP software. Contracts run for a fixed period, usually one year. An STSC will be required for each PC on which you are running N5978A automation scripts.

Get protocol logs for verification and debug

Software tools available for the PXT and 8960 provide logging of protocol exchanges between the test set and the UE. The logs are invaluable for verifying correct operation of UE against the test plan and providing users powerful debugging capability when test outcomes deviate from the expected results.

For more information

On the PXT and associated products is available at:
www.agilent.com/find/PXT

On Agilent LTE solutions is available at:
www.agilent.com/find/LTE

Remove all doubt

Our repair and calibration services will get your equipment back to you, performing like new, when promised. You will get full value out of your Agilent equipment throughout its lifetime. Your equipment will be serviced by Agilent-trained technicians using the latest factory calibration procedures, automated repair diagnostics and genuine parts. You will always have the utmost confidence in your measurements.

Agilent offers a wide range of additional expert test and measurement services for your equipment, including initial start-up assistance onsite education and training, as well as design, system integration and product management.

For more information on repair and calibration services, go to:

www.agilent.com/find/removealldoubt



Agilent Email Updates

www.agilent.com/find/emailupdates
Get the latest information on the products and applications you select.



Agilent Direct

www.agilent.com/find/agilentdirect
Quickly choose and use your test equipment solutions with confidence.

Microsoft, Windows, Visual Studio .NET, Visual Basic, and Excel are U.S. registered trademarks of Microsoft Corporation

cdma2000 is a registered certification mark of the Telecommunications Industry Association. Used under license.

www.agilent.com

For more information on Agilent Technologies' products, applications, or services, please contact your local Agilent office. The complete list is available at:

www.agilent.com/find/contactus

Americas

Canada	(877) 894-4414
Latin America	305 269 7500
United States	(800) 829-4444

Asia Pacific

Australia	1 800 629 485
China	800 810 0189
Hong Kong	800 938 693
India	1 800 112 929
Japan	0120 (421) 345
Korea	080 769 0800
Malaysia	1 800 888 848
Singapore	1 800 375 8100
Taiwan	0800 047 866
Thailand	1 800 226 008

Europe & Middle East

Austria	01 36027 71571
Belgium	32 (0) 2 404 93 40
Denmark	45 70 13 15 15
Finland	358 (0) 10 855 2100
France	0825 010 700* *0.125 €/minute
Germany	07031 464 6333**
Ireland	1890 924 204
Israel	972-3-9288-504/544
Italy	39 02 92 60 8484
Netherlands	31 (0) 20 547 2111
Spain	34 (91) 631 3300
Sweden	0200-88 22 55
Switzerland	0800 80 53 53
United Kingdom	44 (0) 118 9276201

Other European countries:

www.agilent.com/find/contactus

Revised October 1, 2008

Product specifications and descriptions in this document subject to change without notice.

© Agilent Technologies, Inc. 2011
Printed in USA, December 17, 2011
5989-7851EN



Agilent Technologies