

Keysight X-Series Signal Analyzers

This manual provides documentation for the following Analyzers:

PXA Signal Analyzer N9030A
CXA Signal Analyzer N9000A

MXA Signal Analyzer N9020A
EXA Signal Analyzer N9010A

Notice: This document contains references to Agilent. Please note that Agilent's Test and Measurement business has become Keysight Technologies. For more information, go to www.keysight.com.

N6156A &
W6156A
DTMB (CTTB)
Measurement
Application
Measurement
Guide

Notices

© Keysight Technologies, Inc.
2008-2014

No part of this manual may be reproduced in any form or by any means (including electronic storage and retrieval or translation into a foreign language) without prior agreement and written consent from Keysight Technologies, Inc. as governed by United States and international copyright laws.

Trademark Acknowledgements

WiMAX™, WiMAX Forum®, the WiMAX Forum Logo, Mobile WiMAX™, WiMAX Forum Certified™, the WiMAX Forum Certified Logo, and Fixed WiMAX™ are US trademarks of the WiMAX Forum.

Manual Part Number

N6156-90004

Print Date

August 2014

Supersedes: August 2012

Printed in USA

Keysight Technologies Inc.
1400 Fountaingrove Parkway
Santa Rosa, CA 95403

Warranty

THE MATERIAL CONTAINED IN THIS DOCUMENT IS PROVIDED “AS IS,” AND IS SUBJECT TO BEING CHANGED, WITHOUT NOTICE, IN FUTURE EDITIONS. FURTHER, TO THE MAXIMUM EXTENT PERMITTED BY APPLICABLE LAW, KEYSIGHT DISCLAIMS ALL WARRANTIES, EITHER EXPRESS OR IMPLIED WITH REGARD TO THIS MANUAL AND ANY INFORMATION CONTAINED HEREIN, INCLUDING BUT NOT LIMITED TO THE IMPLIED WARRANTIES OF MERCHANTABILITY AND FITNESS FOR A PARTICULAR PURPOSE. KEYSIGHT SHALL NOT BE LIABLE FOR ERRORS OR FOR INCIDENTAL OR CONSEQUENTIAL DAMAGES IN CONNECTION WITH THE FURNISHING, USE, OR PERFORMANCE OF THIS DOCUMENT OR ANY INFORMATION CONTAINED HEREIN. SHOULD KEYSIGHT AND THE USER HAVE A SEPARATE WRITTEN AGREEMENT WITH WARRANTY TERMS COVERING THE MATERIAL IN THIS DOCUMENT THAT CONFLICT WITH THESE TERMS, THE WARRANTY TERMS IN THE SEPARATE AGREEMENT WILL CONTROL.

Technology Licenses

The hardware and/or software described in this document are furnished under a license and may be used or copied only in accordance with the terms of such license.

Restricted Rights Legend

If software is for use in the performance of a U.S. Government prime contract or subcontract, Software is delivered and licensed as “Commercial computer software” as defined in DFAR 252.227-7014 (June 1995), or as a “commercial item” as defined in FAR 2.101(a) or as “Restricted computer software” as defined in FAR 52.227-19 (June 1987) or any equivalent agency regulation or contract clause. Use, duplication or disclosure of Software is subject to Keysight Technologies’ standard commercial license terms, and non-DOD Departments and Agencies of the U.S. Government will receive no greater than Restricted Rights as defined in FAR 52.227-19(c)(1-2) (June 1987). U.S. Government users will receive no greater than Limited Rights as defined in FAR 52.227-14 (June 1987) or DFAR 252.227-7015 (b)(2) (November 1995), as applicable in any technical data.

Safety Notices

CAUTION

A **CAUTION** notice denotes a hazard. It calls attention to an operating procedure, practice, or the like that, if not correctly performed or adhered to, could result in damage to the product or loss of important data. Do not proceed beyond a CAUTION notice until the indicated conditions are fully understood and met.

WARNING

A **WARNING** notice denotes a hazard. It calls attention to an operating procedure, practice, or the like that, if not correctly performed or adhered to, could result in personal injury or death. Do not proceed beyond a WARNING notice until the indicated conditions are fully understood and met.

Where to Find the Latest Information

Documentation is updated periodically. For the latest information about these products, including instrument software upgrades, application information, and product information, browse to one of the following URLs, according to the name of your product:

<http://www.keysight.com/find/pxa>

<http://www.keysight.com/find/mxa>

<http://www.keysight.com/find/exa>

<http://www.keysight.com/find/cxa>

To receive the latest updates by email, subscribe to Keysight Email Updates at the following URL:

<http://www.keysight.com/find/emailupdates>

Information on preventing analyzer damage can be found at:

<http://www.keysight.com/find/tips>

Is your product software up-to-date?

Periodically, Keysight releases software updates to fix known defects and incorporate product enhancements. To search for software updates for your product, go to the Keysight Technical Support website at:

<http://www.keysight.com/find/techsupport>

Table of Contents

1 About the DTMB (CTTB) Measurement Application

What Does the DTMB (CTTB) Application Do?	10
---	----

2 Making DTMB (CTTB) Measurements

Setting Up and Making a Measurement	12
Making the Initial Signal Connection and Configuring the Measurement System	12
Setting up the DTMB (CTTB) Transmitter (Example)	13
Using Analyzer Mode and Measurement Presets	13
The 3 Steps to Set Up and Make Measurements	13
Common Measurement Steps – Setting up the DTMB (CTTB) Mode	16
Channel Power Measurements	19
ACP Measurements	22
Power Statistics CCDF Measurements	24
Troubleshooting Hints	25
Spectrum Emission Mask Measurements	26
Troubleshooting Hints	27
Modulation Accuracy Measurements	29
Monitor Spectrum Measurements	34
IQ Waveform (Time Domain) Measurements	36
Using Option BBA Baseband I/Q Inputs	38
Baseband I/Q Measurements Available for X-Series Signal Analyzers	38
Baseband I/Q Measurement Overview	39

3 Concepts

Introduction	42
What Is the DTMB (CTTB) Broadcast System?	43
Key Technologies	44
FEC	44

Contents

Frame Structure	44	
TDS-OFDM	44	
Channel Power Measurement Concepts		46
Purpose	46	
Measurement Method	46	
Adjacent Channel Power (ACP) Measurement Concepts		48
Purpose	48	
Measurement Method	48	
Power Statistics CCDF Measurement Concepts		50
Purpose	50	
Measurement Method	50	
Spectrum Emission Mask Measurement Concepts		52
Purpose	52	
Measurement Method	52	
Using Amplitude Correction in Spectrum Emission Mask Measurement		54
Modulation Accuracy Measurement Concepts		56
Purpose	56	
Measurement Method	56	
Monitor Spectrum Measurement Concepts		59
Purpose	59	
Measurement Method	59	
Troubleshooting Hints	59	
IQ Waveform Measurement Concepts		60
Purpose	60	
Measurement Method	60	
Baseband I/Q Inputs (Option BBA) Measurement Concepts		61
What are Baseband I/Q Inputs?	61	
What are Baseband I/Q Signals?	62	
Why Make Measurements at Baseband?	62	
Selecting Input Probes for Baseband Measurements		63
Baseband I/Q Measurement Views	64	
Other Sources of Measurement Information		66

Instrument Updates at www.keysight.com	66
References	67

1 About the DTMB (CTTB) Measurement Application

This chapter provides the overall information on the N6156A (for PXA, MXA, EXA) & W6156A (for CXA) DTMB (CTTB) measurement application, and describes DTMB (CTTB) measurements made by the analyzer.

DTMB (Digital terrestrial/television multimedia broadcasting), also known as CTTB (China Terrestrial Television Broadcasting), is the Chinese National Terrestrial Digital TV Broadcasting Standard which is announced on August 18, 2006 and implemented from August 1, 2007.

What Does the DTMB (CTTB) Application Do?

The DTMB (CTTB) application allows the analyzer to be used for testing a DTMB (CTTB) transmitter/exciter. This application is manufactured according to the following standard documents:

- GB 20600-2006 Framing Structure, Channel Coding and Modulation for Digital Television Terrestrial Broadcasting System
- GY/T 229.4-2008 Technical specifications and methods of measurement for digital terrestrial television broadcasting transmitters
- GY/T 229.2-2008 Technical Specifications and methods of measurement for digital terrestrial television broadcasting exciter

These documents define complex, multi-part measurements used to create and maintain an interference-free environment. For example, the documents include standardized test methods for the measurement of power, spectrum emission mask, and other critical measurements.

The instrument automatically makes these measurements using the measurement methods and limits defined in the documents. The detailed results displayed by the measurements enable you to analyze DTMB (CTTB) transmitter/exciter's performance. You may alter the measurement parameters for specialized analysis. For infrastructure test, the analyzer will test transmitters/exciter in a non-interfering manner using a coupler or power splitter.

This analyzer makes the following measurements of DTMB (CTTB) signals:

- Channel Power
- Adjacent Channel Power (ACP)
- Power Stat CCDF
- Spectrum Emission Mask
- Modulation Accuracy
- Monitor Spectrum
- IQ Waveform (Time Domain)

If the option BBA is installed, the ability to analyze baseband I/Q signal characteristics of mobile and base station transmitters is provided. The Baseband I/Q Input is available in the following measurements:

- Modulation Accuracy
- Power Stat CCDF
- IQ Waveform (Time Domain)

2 Making DTMB (CTTB) Measurements

This chapter first introduces the instructions common to all measurements, and then, discusses the instructions specific to individual measurement, as follows.

- “Channel Power Measurements” on page 19
- “ACP Measurements” on page 22
- “Power Statistics CCDF Measurements” on page 24
- “Spectrum Emission Mask Measurements” on page 26
- “Modulation Accuracy Measurements” on page 29
- “Monitor Spectrum Measurements” on page 34
- “IQ Waveform (Time Domain) Measurements” on page 36

Setting Up and Making a Measurement

Making the Initial Signal Connection and Configuring the Measurement System

Set the DTMB (CTTB) transmitter under test to transmit the RF power. This transmitting signal is connected to the RF input port of the instrument. Connect the equipment as shown.

CAUTION

Before connecting a signal to the analyzer, make sure the analyzer can safely accept the signal level provided. The signal level limits are marked next to the RF Input connectors on the front panel.

1. Connect the output signal from the DTMB (CTTB) transmitter to the RF input port of the analyzer using appropriate cables, attenuators, and adapters.
2. Optional: If there is a frequency reference port on the DTMB (CTTB) transmitter, connect it to the EXT REF IN port of the analyzer with a cable for frequency synchronization.

Figure 2-1

DTMB (CTTB) Measurement System

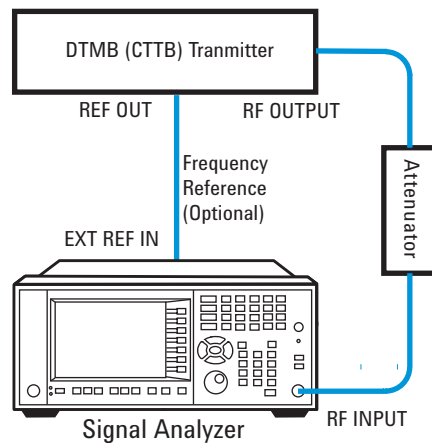

After finishing the connection, see the Input/Output key menus for details on selecting input ports and AMPTD Y Scale menu for details on setting internal attenuation to prevent overloading of the analyzer.

NOTE

The parameters under **Input/Output** menu can't be reset by pressing **Mode Preset**. Then if you've made any changes to the Input/output parameters which aren't required in another measurement, remember to restore those settings manually.

Setting up the DTMB (CTTB) Transmitter (Example)

Set up the DTMB (CTTB) transmitter to transmit the RF power as follows:

Frequency: 666 MHz (Channel Num: 32, Channel Table: PAL-D/K DS)

Bandwidth: 8 MHz

Frame Header Type: PN420

Modulation Type: 4 QAM

Subcarrier number: 3780

Attenuator: 60 dB

Transmitted Power: 40 dBm (at RF output); -20 dBm (at the analyzer input)

Using Analyzer Mode and Measurement Presets

To set your current measurement mode to a known factory default state, press **Mode Preset**. This initializes the analyzer by returning the mode setup and all of the measurement setups in the mode to the factory default parameters.



To preset the parameters that are specific to an active, selected measurement, press **Meas Setup, Meas Preset**. This returns all the measurement setup parameters to the factory defaults, but only for the currently selected measurement.

The 3 Steps to Set Up and Make Measurements

Generally speaking, all measurements can be set up using the following three steps in [Table 2-2](#). [Table 2-2](#) shows the main keys and functions that may be used while following the steps. For the detailed procedures for a specific measurement, refer to:

- “Channel Power Measurements” on page 19
- “ACP Measurements” on page 22
- “Power Statistics CCDF Measurements” on page 24
- “Spectrum Emission Mask Measurements” on page 26
- “Modulation Accuracy Measurements” on page 29
- “Monitor Spectrum Measurements” on page 34
- “IQ Waveform (Time Domain) Measurements” on page 36

NOTE

Press the  key on the front panel to enter the help system and see detailed descriptions for the keys you are not familiar with. Press the  key on the front panel to exit the help system..

Making DTMB (CTTB) Measurements
Setting Up and Making a Measurement

Table 2-1 The 3 Steps to Set Up and Make a Measurement

Step	Action	Notes
Select and Set Up the Mode	<ul style="list-style-type: none"> a. Press Mode. b. Press a mode key, like Spectrum Analyzer, or DTMB (CTTB). c. Press Mode Preset. d. Press Mode Setup. 	<p>All licensed, installed modes are shown under the Mode key.</p> <p>Using Mode Setup, make any required adjustments to the mode settings. These settings apply to all measurements in the mode.</p>
Select and Set Up the Measurement	<ul style="list-style-type: none"> a. Press Meas. b. Select the specific measurement to be performed. c. Press Meas Setup. 	<p>The resulting data is shown on the display or is available for export.</p> <p>Use Meas Setup to make any required adjustment to the selected measurement settings. The settings only apply to this measurement.</p>
Select and Set Up a View of the Results	Press View/Display . Set display format and select a view for the current measurement data.	<p>Depending on the mode and measurement selected, the graphical and tabular data presentations are available.</p> <p>Use Span X Scale and AMPTD Y Scale to adjust the display of the measurement graphics.</p>

NOTE You can change the settings as needed, and the changes will be in effect on the next measurement cycle or view.

Table 2-2 Main Keys and Functions for Making Measurements

Step	Primary Key	Setup Keys	Related Keys
1 Select and set up a mode.	Mode	Mode Setup, FREQ Channel	System
2 Select and set up a measurement.	Meas	Meas Setup	BW, Sweep/Control, Input/Output, Restart, Single, Cont
3 Select and set up a view of the results.	View/Display	SPAN X Scale, AMPTD Y Scale	Peak Search, Quick Save, Save, Recall, File, Print

NOTE

If you encounter a problem, or get an error message, see the guide “**Instrument Messages**”, which is provided on the Documentation CD ROM, and in the instrument here:

C:\Program Files\Keysight\SignalAnalysis\Infrastructure\Help\bookfiles.

Common Measurement Steps – Setting up the DTMB (CTTB) Mode

This section lists the steps common to all measurements in DTMB (CTTB) mode. Whatever measurements you are making, you need to begin with the following steps:

Step	Notes
Press Mode, DTMB (CTTB) .	
Press Mode Preset .	
Press Mode Setup, Device Type, Transmitter .	This sets the device type to transmitter.
Do one of the following to set center frequency: <ul style="list-style-type: none"> • Press FREQ Channel, Center Freq, 666, MHz. • Press FREQ Channel, Chan Table, PAL-D/K, PAL-D/K DS, and then press FREQ Channel, Channel, 32. 	The first method is to enter the frequency directly. The second method is to set the frequency through channel table. Multiple channel tables are predefined in the instrument, including NTSC-M, NTSC-J, NTSC-Brazil, PAL-M, PAL-I, PAL-B/G, and PAL-D/K. You can change the definition of the channel table following the steps in “Customizing the Channel Table Definition” on page 16 .
Press Mode Setup, Channel BW, 8 MHz .	This sets the channel band width.

Customizing the Channel Table Definition

Channel table function enables you to specify the center frequency by entering the channel number under a specific channel table. In a channel table, each channel number corresponds to a center frequency exactly. The predefined channel table complies with the industry standards.

A channel table file is used to export, edit, and then import the channel table settings so that you can customize the channel table to satisfy your measurement requirements.

The format of the channel table file is illustrated in [Figure 2-2](#). The channel table file includes channel definitions for all the channel plans, such as NTSC-B, NTSC-J, NTSC-M, PAL-M, PAL-I, PAL-B/G, and PAL-D/K. Each channel plan is separated with a blank line.

File default location: My Documents\Digital Video\data

File type: text file

File extension: .txt

Figure 2-2 *Format of the Channel Table File*

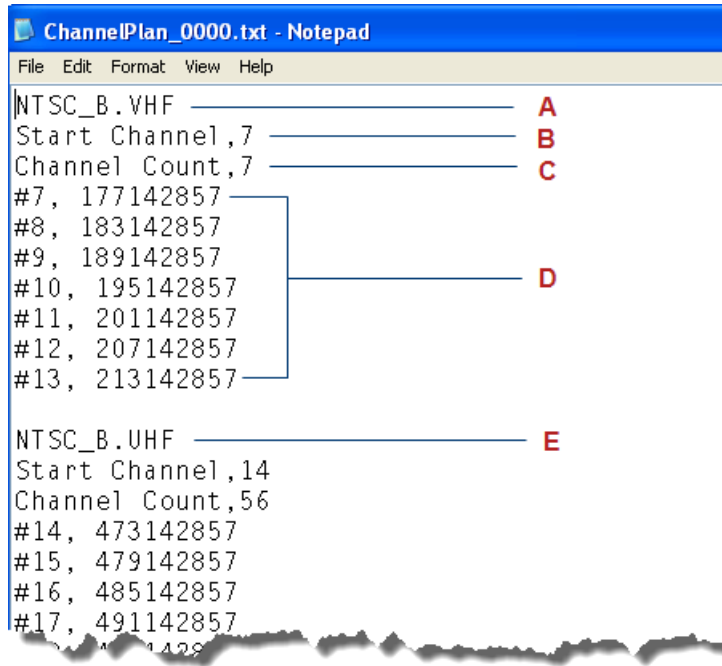

- A. Channel plan name. This is the channel plan for NTSC-B VHF;
- B. Start channel number. Here, the start channel number is 7;
- C. Channel count in the current channel plan. There are 7 channels in the predefined NTSC-B VHF.
- D. Channel number and corresponding center frequency, unit Hz. For example, #7, 177142857 means the center frequency for the channel 7 is 177142857 Hz.
- E. The start of another channel plan NTSC-B UHF.

Perform the following steps to customize the channel table:

Step	Notes
<p>1 Press Save, Data, Channel Table, and then press Save As..., save the current channel table file as ChannelPlan_0000.txt (for example).</p>	<p>This saves the data of the current channel table into a file. You can save the file into the default directory "My Documents\Digital Video\data" or any other locations you like.</p>

Making DTMB (CTTB) Measurements
Setting Up and Making a Measurement

Step	Notes
<hr/> 2 Open the saved channel table file ChannelPlan_0000.txt, find the channel plan you are going to edit, and then make your desired changes.	<p>You can add your own channel definitions to the channel table file, edit the center frequency value for the predefined channel, or remove the channel definitions unnecessary for your test.</p> <ul style="list-style-type: none"><li data-bbox="691 422 1433 667">• Adding channel definitions First, choose and find the channel plan you're going to edit on, for example, NTSC_B.VHF. Then, add the channel definitions including channel number and corresponding center frequency following the format "# channel number, center frequency". After that, edit the Start Channel and Channel Count values according to your changes.<li data-bbox="691 695 1433 804">• Editing the center frequency value for the channel Choose and find the channel plan you're going to edit, and then enter the center frequency value for the channel.<li data-bbox="691 831 1433 972">• Removing unnecessary channel definitions Choose and find the channel plan you're going to edit, and then delete the unnecessary channel definition. After that edit the Start Channel and Channel Count values. <p>Note that the name of the channel plan couldn't be changed. If it is changed, the modifications under this channel plan will not work and the default channel settings of the channel plan will work instead.</p>
<hr/> 3 Press Recall, Data, Channel Table , then press Open... , and open the channel table file you edited.	
<hr/> 4 Press FREQ Channel to specify the center frequency under the new channel table.	<hr/> If the instrument is restarted, the channel table file needs to be recalled again.

Channel Power Measurements

This section explains how to make a Channel Power measurement on a DTMB (CTTB) transmitter. Channel Power measurement measures the total RF power, shoulder attenuation present in the channel, and provides a view that compares the input signal against the DTMB (CTTB) defined spectrum mask when there is an analog TV signal in an adjacent channel.

Step	Notes
1 Set up the DTMB (CTTB) mode parameters according to “Common Measurement Steps – Setting up the DTMB (CTTB) Mode” on page 16	If the DTMB (CTTB) mode is NOT set up properly, the measurement results will be incorrect.
2 Press Meas, Channel Power .	This selects the Channel Power measurement.
3 Press View/Display, RF Spectrum .	This selects the RF Spectrum view.
4 View the RF Spectrum results.	In the figure below, the graph window shows the spectrum trace and the text window shows the total power and PSD (power spectral density) level over 8 MHz.

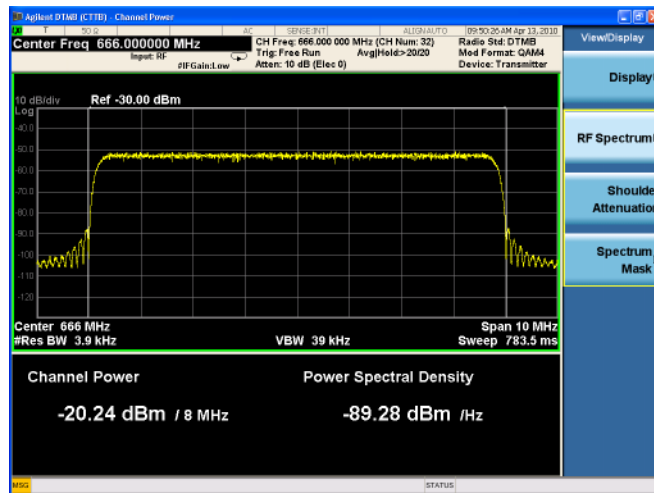

To change the measurement integration band width, press **Meas Setup, Integ BW**.

5 Press View/Display, Shoulder Attenuation ;	This selects the Shoulder Attenuation view.
---	---

Step

Notes

6 View the shoulder attenuation results.

In the figure below, the text window shows the shoulder attenuation value and shoulder points information.

To make the measurement on a specified frequency range, press **Meas Setup** and set the values for **Shoulder Offset Start** and **Shoulder Offset Stop** correspondingly.

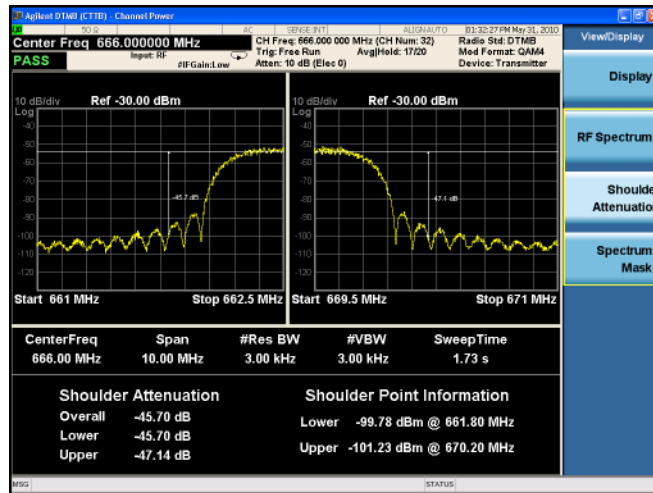

To learn more about the measurement method of shoulder attenuation, refer to “Shoulder Attenuation” on page 46.

7 Press **Input/Output, External Gain, Ext Preamp, -60, dB**

This sets the value for the external attenuator.

8 Press **Input/Output, More 1 of 2, Corrections**, toggle the **Correction** key to **On**, and then do one of the following to specify correction data:

This applies amplitude correction.

- Press **Edit** and enter the frequency and amplitude data.
- Press **Recall, Data (Import) Amptd Cor1, Open** to import the correction file.

To get the format of the file to be recalled, first edit several points using the onscreen editor, then press **Save, Data (Export) Correction 1, Save As...** to save the correction data to a file. Open the file, and view the format.

For more information regarding amplitude correction and the definition of correction data, refer to “Using Amplitude Correction in Spectrum Emission Mask Measurement” on page 54.

9 Press **View/Display, Spectrum Mask**.

This selects the Spectrum Mask view.

For more details about the definition of the spectrum mask, refer to “Spectrum Mask” on page 46.

Step

Notes

10 View the spectrum mask results.

Use this view when an analog TV signal is present in an adjacent channel. As in the figure below, the text window shows the total power, power spectral density, and the failed point list.

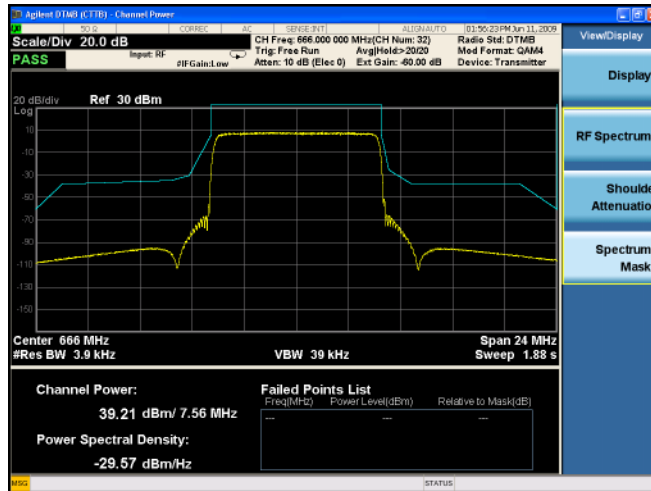

If the device type is exciter or the channel band width is 6 MHz, no mask trace will be displayed and a “No Result” message will be displayed, as no spectrum masks for those band widths are defined in the specs.

ACP Measurements

This section explains how to make Adjacent Channel Leakage Power Ratio (ACLR or ACPR) measurements on a DTMB (CTTB) transmitter. ACPR is a measurement of the amount of interference, or power, in an adjacent frequency channel. The results are displayed as a bar graph or as spectrum data, with measurement data at specified offsets.

Step	Notes
1 Set up the DTMB (CTTB) mode parameters according to “Common Measurement Steps – Setting up the DTMB (CTTB) Mode” on page 16.	If the DTMB (CTTB) mode is NOT set up properly, the measurement results will be incorrect.
2 Press Meas, ACP .	
3 Press Meas Setup, More 1 of 2, Noise Correction and toggle it to On .	This operation can reduce the noise levels and improve the ACP measurement results.
4 View the ACP measurement results.	In the figure below, the graphic window shows the bar graph with the spectrum trace overlay. The text window shows the absolute total power reference, while the power inside the adjacent channel and outside the adjacent channel are displayed in both absolute and relative readings.

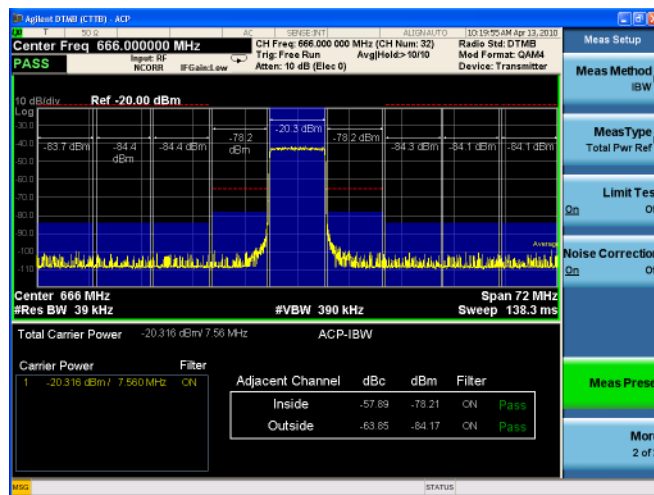

The measurement method and PASS/FAIL limit is described in [Table 3-3](#). If the measurement band width is 6 MHz, there is no default measurement method and PASS/FAIL limit. You can define it manually through **Meas Setup, Offset/Limits**.

Step

Notes

- 5 If the device under test is Exciter, the display of the ACP measurement results is different.

The graph window shows the bar graph with the spectrum trace overlay. The text window shows the total power in reference channel, absolute and relative power in offset channels.

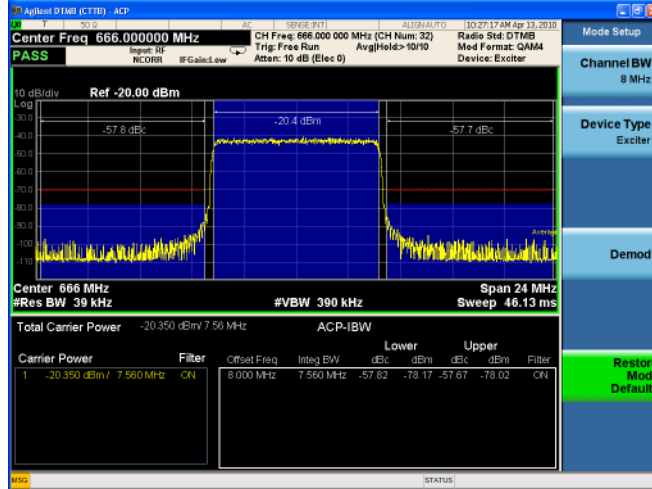

The measurement method and PASS/FAIL limit is described in [Table 3-3](#). If the measurement bandwidth is 6 MHz, there is no default measurement method and PASS/FAIL limit. You can define it manually through **Meas Setup, Offset/Limits**.

Power Statistics CCDF Measurements

This section explains how to make Power Statistics Complementary Cumulative Distribution Function (Power Stat CCDF) measurements on a DTMB (CTTB) transmitter. Power Stat CCDF curves characterize the higher level power statistics of a digitally modulated signal.

Power Statistics CCDF measurements can also be used to measure the BBIQ (Baseband I/Q) signals. For the detailed measurement procedure, refer to [“Using Option BBA Baseband I/Q Inputs”](#) on page 38.

Step	Notes
1 Set up the DTMB (CTTB) mode parameters according to “Common Measurement Steps – Setting up the DTMB (CTTB) Mode” on page 16.	If the DTMB (CTTB) mode is NOT set up properly, the measurement results will be incorrect.
2 Press Power Stat CCDF .	
3 View the Power Stat CCDF measurement results.	In the following figure, the statistic data of the peak to average ratio is listed in the text window.

In the graph window, the blue line is the Gaussian trace and the yellow line is the measurement result. The Info BW is the channel bandwidth that will be used for data acquisition. The default value is 8 MHz. You can manually change the Info BW by pressing **BW**, **Info BW**.

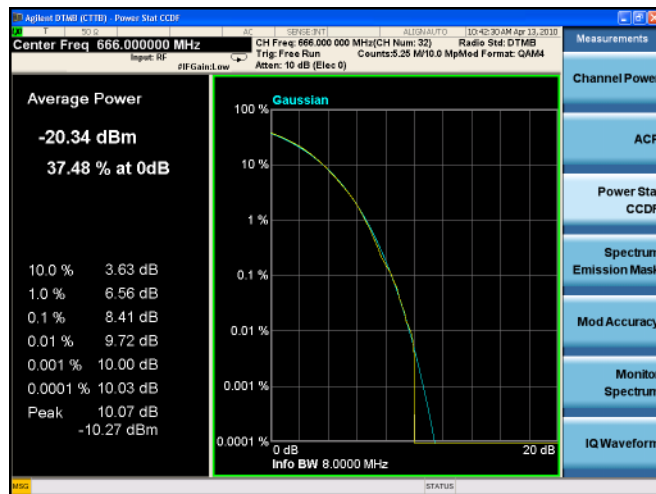

Step

Notes

4 Press **Trace/Detector, Ref Trace (On)** to display the user-definable reference trace (violet line).

The reference trace is a measurement trace stored as a reference trace to be compared to a later measurement. You can use the **Store Ref Trace** key to save the currently measured trace as the reference trace. This reference trace will be lost if you switch between modes or measurements.

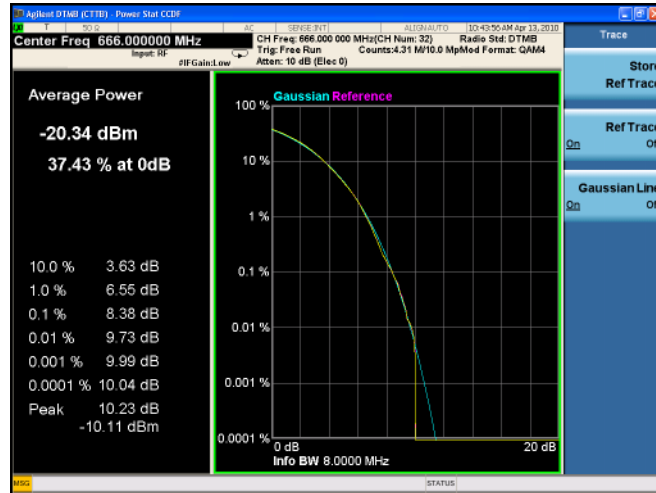

Troubleshooting Hints

The Power Statistics CCDF measurement can contribute in setting the signal power specifications for design criteria for systems, amplifiers, and other components. When the signal power is larger than the limit of the mixer or ADC, the CCDF result trace will deviate from the Gaussian trace.

Spectrum Emission Mask Measurements

This section describes how to make Spectrum Emission Mask (SEM) measurements on a DTMB (CTTB) transmitter. SEM measurements compare the power level within the given offset channels on both sides of the carrier frequency, to the spectrum mask of critical cases defined by the DTMB (CTTB) standard. Results of the measurement on each offset segment can be viewed separately.

Step	Notes
1 Set up the DTMB (CTTB) mode parameters according to “ Common Measurement Steps – Setting up the DTMB (CTTB) Mode ” on page 16.	If the DTMB (CTTB) mode is NOT set up properly, the measurement results will be incorrect.
2 Press Spectrum Emission Mask .	This selects the Spectrum Emission Mask measurement.
3 Press Input/Output, External Gain, Ext Preamp, -60, dB .	This sets the value for the external attenuator to get the actual transmitting power of the transmitter under test.
4 Press Input/Output, More 1 of 2, Corrections , toggle the Correction key to On , and then do one of the following to specify correction data: <ul style="list-style-type: none">• Press Edit and enter the frequency and amplitude data.• Press Recall, Data (Import) Amptd Cor1, Open to import the correction file.	<p>This applies amplitude correction.</p> <p>To get the format of the file to be recalled, first edit several points using onscreen editor, then press Save, Data (Export) Correction 1, Save As... to save the correction data to a file. Open the file, and view the format.</p> <p>For more detailed information regarding amplitude correction and the definition of correction data, refer to “Using Amplitude Correction in Spectrum Emission Mask Measurement” on page 54.</p>

Step

Notes

5 View the Spectrum Emission Mask measurement results.

In the figure below, the top window shows the measured trace together with the limit mask and the bottom window lists the related parameters.

Refer to [Figure 3-5 on page 52](#) and [Table 3-4 on page 53](#) for the definition of the spectrum mask used in this measurement.

To make the spectrum emission mask measurement with your own limit mask, press **Meas Setup** and then set the parameters under **Ref Channel** and **Offset/Limit** panel.

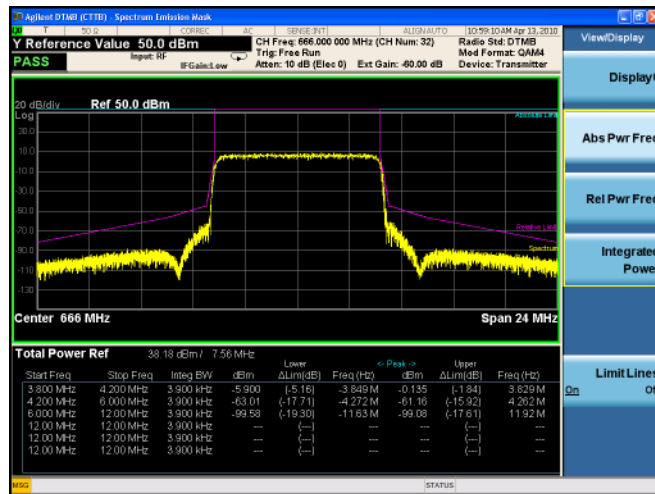

You can zoom on either the graphic window or the text window by pressing the Window Control keys at the left bottom of the front panel.

Troubleshooting Hints

This Spectrum Emission Mask measurement can reveal degraded or defective parts in the transmitter section of the unit under test (UUT). The following examples are those areas to be checked further.

- Faulty DC power supply control of the transmitter power amplifier.
- RF power controller of the pre-power amplifier stage.
- I/Q control of the baseband stage.
- Degradation in the gain and output power level of the amplifier due to the degraded gain control or increased distortion, or both.
- Degradation of the amplifier linearity or other performance characteristics.

Making DTMB (CTTB) Measurements Spectrum Emission Mask Measurements

Power amplifiers are one of the final stage elements of a base or mobile transmitter and are a critical part of meeting the important power and spectral efficiency specifications. Since spectrum emission mask measures the spectral response of the amplifier to a complex wideband signal, it is a key measurement linking amplifier linearity and other performance characteristics to the stringent system specifications.

Modulation Accuracy Measurements

This section explains how to make a Modulation Accuracy measurement on a DTMB (CTTB) transmitter. Modulation Accuracy measurements provide methods for measuring the I/Q errors on DTMB (CTTB) transmitter. The results comprise EVM, MER, magnitude error, phase error, frequency error, clock error, quad error, amplitude imbalance, etc.

Step	Notes
1 Set up the DTMB (CTTB) mode parameters according to “ Common Measurement Steps – Setting up the DTMB (CTTB) Mode ” on page 16.	If the DTMB (CTTB) mode is NOT set up properly, the measurement results will be incorrect.
2 Press Meas, Mod Accuracy .	This selects the Mod Accuracy measurement.
3 Press Mode Setup, Demod , and then under the Demod panel, <ul style="list-style-type: none"> • Press Frame Header, PN420. • Press Carrier Format, OFDM. • Press Modulation Format, 4QAM. 	This sets the demodulation parameters.
4 Press View/Display, I/Q Measured Polar Graph .	This selects the I/Q Measured Polar Graph view.

Making DTMB (CTTB) Measurements Modulation Accuracy Measurements

Step

Notes

5 View the I/Q Measured Polar Graph results.

The figure below displays a combination view of the constellation graph and metric result windows. RMS values, peak values, and peak position for EVM, MER, magnitude error, phase error, frequency error, and Tx power results are listed in the metric result window.

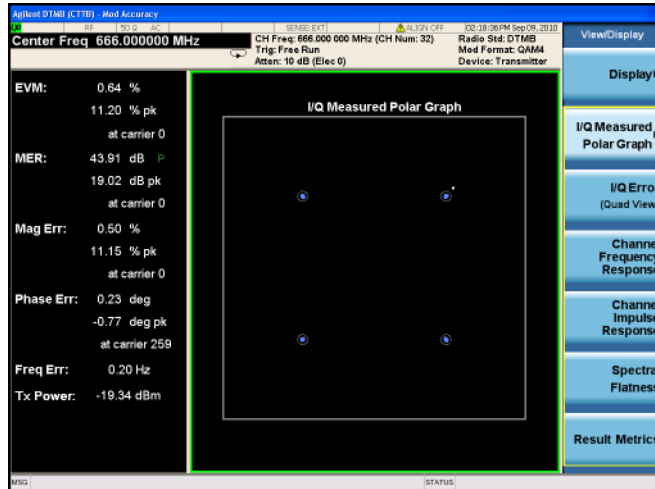

To view the modulation constellation graph for the specified carrier ranges, press **I/Q Measured Polar Graph** again and set the **Start Carrier** and the **Stop Carrier**.

6 Press **View/Display, I/Q Error**.

This selects I/Q Error (Quad View).

7 View the I/Q Error results.

The figure below shows the MER/EVM vs. subcarrier/frequency, spectrum, I/Q measured polar graph, and a result summary.

You can change the scale type for the vertical axis and the horizontal axis in the top left window by setting the Scale Type key under AMPTD Y Scale and Span X Scale.

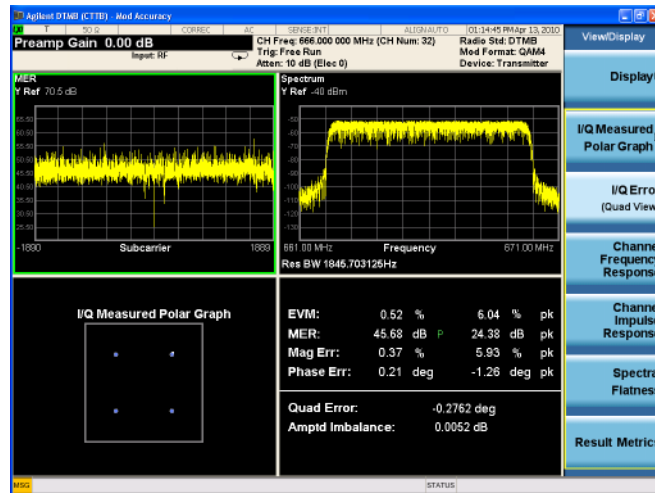

Step

Notes

8 Press View/Display, Channel Frequency Response.

This selects the Channel Frequency Response view.

9 View the channel frequency response results.

The figure below displays the amplitude, phase, and group delay on every subcarrier.

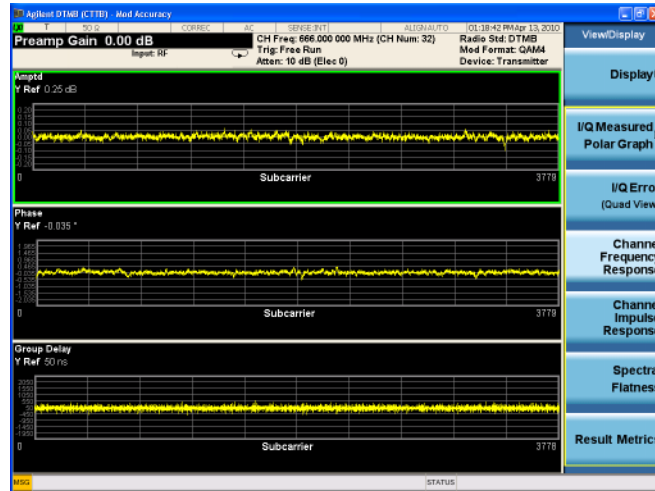

10 Press View/Display, Channel Impulse Response, and then press Meas Setup, Advanced, Equalization, toggle it to ON.

This selects Channel Impulse Response view, and turns on the equalizer to get better channel impulse response results.

11 View the Channel Impulse Response results.

In the figure below, the graphic window shows the channel impulse response trace, and the text window shows a peak table listing the top 10 peaks on the trace at most. The green line with -35 dB above its right side is the peak limit line, which means only peaks above this line can be displayed in the peak table.

To adjust the peak limit line, press **Peak Search, More 1 of 2, Peak Table**, and then enter your desired peak limit value.

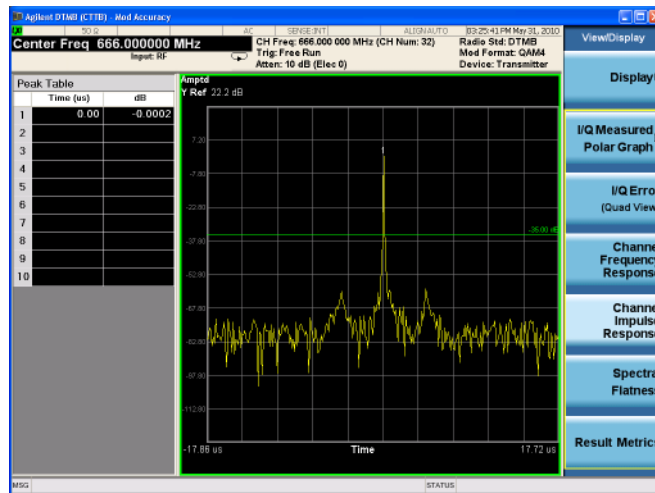

Making DTMB (CTTB) Measurements Modulation Accuracy Measurements

Step

Notes

12 Press View/Display, Spectral Flatness.

This selects the spectral flatness view.

13 View the spectral flatness results.

The figure below displays the inband spectrum ripple. According to the standard, the spectrum flatness should be less than $\pm 0.5\text{dB}$. The PASS/FAIL in the top left corner indicates the test result.

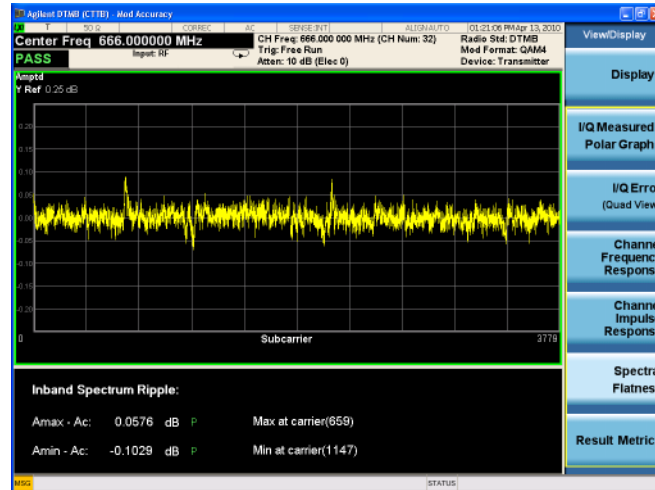

14 Press View/Display, More 1 of 2, Result Metrics.

This selects the Result Metrics view.

15 View the summary of the measurement results.

The figure below displays a summary of the measurement results, including the MER results of all the data, data block, system information, or header.

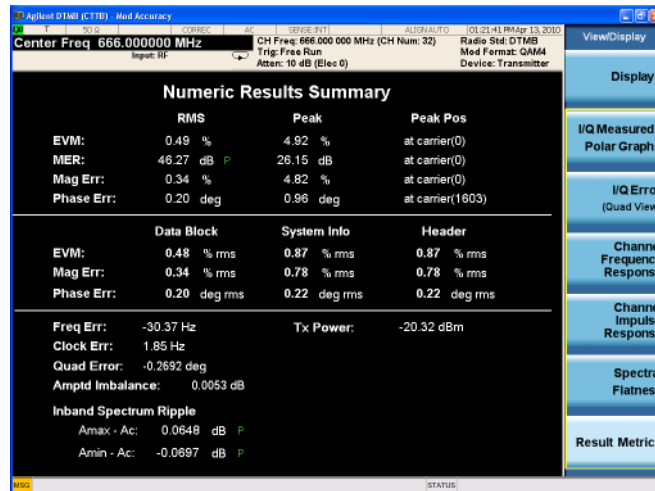

NOTE

To place a Marker on the different traces of the various views, press **Marker, Properties**, Marker Trace, then select the trace you want to put the marker on. There are seven traces to select from: Polar Trace, MER/EVM vs.Carr/Freq, Spectrum, Amptd vs.Carr, Phase vs.Carr, GD vs.Carr, and Amptd vs.Time.

Monitor Spectrum Measurements

This section explains how to make a Monitor Spectrum measurement on a DTMB (CTTB) transmitter. Monitor Spectrum measurements show a spectrum domain display of the DTMB (CTTB) signal.

Step	Notes
1 Set up the DTMB (CTTB) mode parameters according to “Common Measurement Steps – Setting up the DTMB (CTTB) Mode” on page 16.	If the DTMB (CTTB) mode is NOT set up properly, the measurement results will be incorrect.
2 Press Meas, Monitor Spectrum .	This selects monitor spectrum view.
3 View the monitor spectrum results.	The default display shows the Current (yellow trace) data.

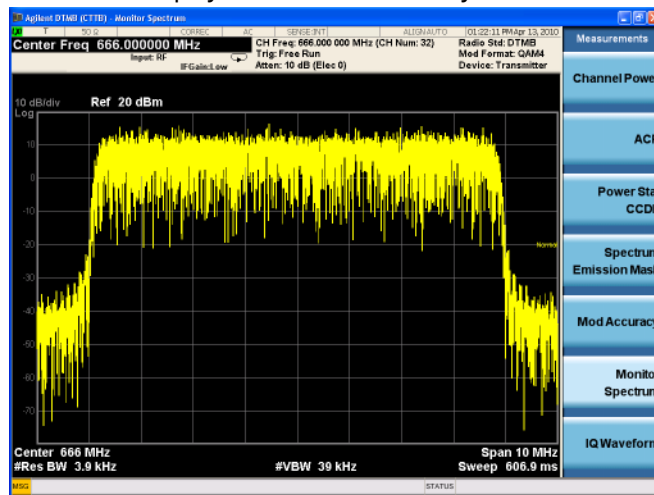

Step

Notes

- 4 (Optional) Press **Marker Function, Marker Noise**.

This turns on the Marker Function. The figure below is an example for marker noise. You can also select Band/Interval Power and Band/Interval Density to see the power or power density in a specified band, which is set using the keys under the **Band Adjust** menu.

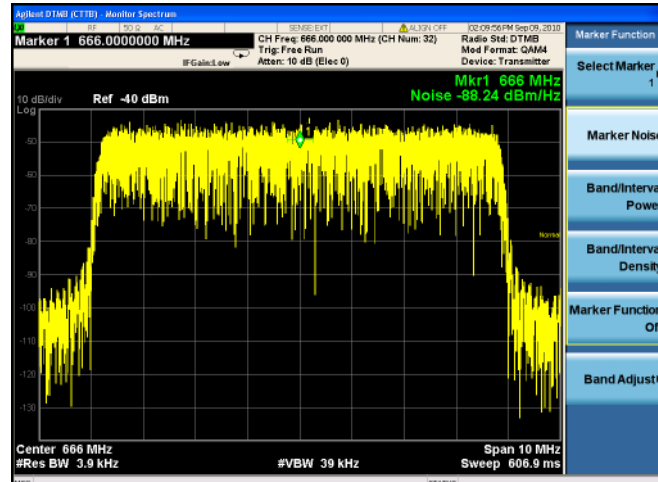

- 5 (Optional) To compare the current trace with the average/max hold/min hold trace, perform the following steps:

The dark yellow trace is the clear write trace, and the blue trace is the max hold trace. You can also add other traces using the same procedure.

- Press **Trace/Detector, Select Trace, Trace 1**, and then toggle **Update** to **Off**.
- Press **Select Trace, Trace 2**, press **Max Hold**, and then toggle **Update** to **On, Display** to **Show**.

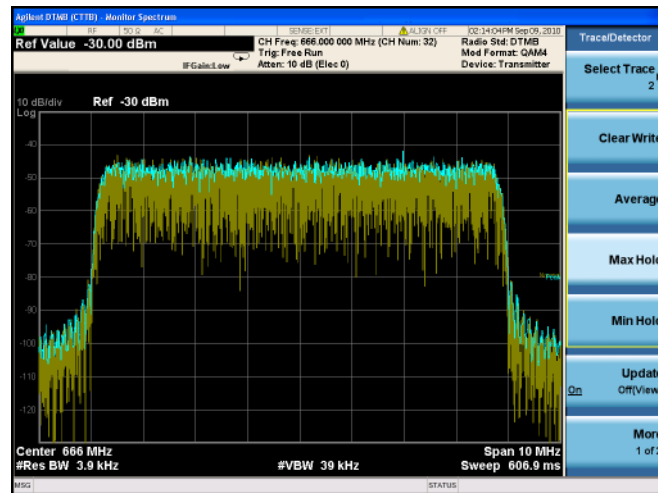

IQ Waveform (Time Domain) Measurements

This section explains how to make a Waveform (time domain) measurement on a DTMB (CTTB) transmitter. The measurement of I and Q modulated waveforms in the time domain disclose the voltages which comprise the complex modulated waveform of a digital signal.

IQ Waveform measurements can be used to measure the BBIQ (Baseband I/Q) signals. For the detailed measurement procedure, refer to [“Using Option BBA Baseband I/Q Inputs”](#) on page 38.

Step	Notes
1 Set up the DTMB (CTTB) mode parameters according to “Common Measurement Steps – Setting up the DTMB (CTTB) Mode” on page 16.	If the DTMB (CTTB) mode is NOT set up properly, the measurement results will be incorrect.
2 Press Meas, IQ Waveform.	This selects the IQ waveform measurements.
3 Press View/Display,	
4 View the RF envelope (default view) results.	The following picture shows the RF envelope results in the graphic windows, and shows the mean power and peak-to-mean power results in the text window.

5 Press **View/Display, I/Q Waveform.** This selects the I/Q waveform view.

Step

Notes

6 View the I/Q waveform results.

The I/Q waveform view displays the I (yellow trace) and Q (blue trace) waveforms on the same graph in terms of voltage versus time in linear scale.

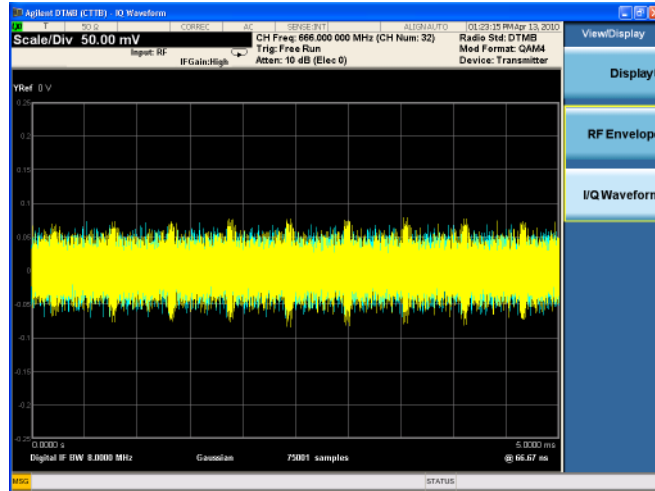

7 (Optional) Press **AMPTD Y Scale**, and configure the settings for the Y axis to a convenient scale for viewing.

8 (Optional) Press **Span X Scale**, and configure the settings for the X axis to a convenient time scale for viewing.

9 (Optional) Press **Marker Function** and select **Marker Noise**, **Band/Interval Power**, or **Band/Interval Density**.

You can use band adjust to set frequency span for those marker functions.

Using Option BBA Baseband I/Q Inputs

Baseband I/Q Measurements Available for X-Series Signal Analyzers

The following table shows the measurements that can be made using Baseband I/Q inputs:

Table 2-3

BBIQ Supported Measurements vs. Mode

Mode	Measurements
GSM	IQ Waveform GMSK Phase & Freq EDGE EVM
TD-SCDMA	IQ Waveform Power Stat CCDF Code Domain Mod Accuracy
cdma2000	IQ Waveform Power Stat CCDF Code Domain Mod Accuracy QPSK EVM
DTMB (CTTB)	IQ Waveform Power Stat CCDF Mod Accuracy
DVB-T/H with T2	IQ Waveform Power Stat CCDF DVB-T/H Mod Accuracy DVB-T2 Mod Accuracy
CMMB	IQ Waveform Power Stat CCDF Mod Accuracy
ISDB-T	IQ Waveform Power Stat CCDF Mod Accuracy
Digital Cable TV	IQ Waveform Power Stat CCDF Mod Accuracy
IQ Analyzer (Basic)	IQ Waveform Complex Spectrum

Baseband I/Q Measurement Overview

The Baseband I/Q functionality is a hardware option, Option BBA. If the option is not installed in the instrument, the I/Q functionality cannot be enabled.

The Baseband I/Q option provides four input ports and one Calibration Output port. The input ports are I, I-bar, Q, and Q-bar. The I and I-bar together compose the I channel and the Q and Q-bar together compose the Q channel. Each channel has two modes of operation:

Single Ended
(unbalanced)

In this mode, only the main port (I or Q) is used and the complementary ports (I-bar or Q-bar) are ignored. The I and Q ports are in single-ended mode when Differential “Off” is selected.

Differential
(balanced)

In this mode, both main and complementary ports are used. To activate this mode, select Differential “On” from the I and Q Setup softkey menus.

The system supports a variety of input passive probes as well as the Keysight 1153A active differential probe using the Infinimax probe interface.

NOTE

To avoid duplication, this section describes only the details unique to using the baseband I/Q inputs. For generic measurement details, refer to the previous [“Making DTMB \(CTTB\) Measurements” on page 11](#) sections.

To make measurements using baseband I/Q Inputs, make the following selections:

Step	Notes
1 Select a measurement that supports baseband I/Q inputs by pressing Meas .	Table 2-3 on page 38 lists the measurements that support baseband I/Q inputs in each mode.
2 Select the I/Q Path. Press Input/Output, I/Q, I/Q Path , and then select from the choices present on the screen.	The path selected in this step is shown at the top of the measurement screen.
3 Select the appropriate circuit location and probe(s) for measurements.	For details see “Selecting Input Probes for Baseband Measurements” on page 63 in the Concepts chapter.
4 Select baseband I/Q input connectors and connect the I/Q signals to the corresponding I/Q ports on the instrument..	

Making DTMB (CTTB) Measurements
Using Option BBA Baseband I/Q Inputs

Step	Notes
<p>5 If you have set the I/Q Path to I+jQ or to I Only, press I Setup.</p> <p>A. Select whether Differential (Balanced) input is On or Off.</p> <p>B. Select the input impedance, Input Z.</p> <p>C. Input a Skew value in seconds.</p> <p>D. Set up the I Probe by pressing I Probe.</p> <p>a. Select probe Attenuation.</p> <p>b. Calibrate the probe. Press Calibrate... to start the calibration procedure. Follow the calibration procedure, clicking Next at the end of each step.</p>	
<p>6 If you have set the I/Q Path to I+jQ or to Q Only, press Q Setup.</p> <p>A. Select whether Differential (Balanced) input is On or Off.</p> <p>B. Select the input impedance, Input Z.</p> <p>C. Input a Skew value in seconds.</p> <p>D. Set up the I Probe by pressing I Probe.</p> <p>a. Select probe Attenuation.</p> <p>b. Calibrate the probe. Press Calibrate... to start the calibration procedure. Follow the calibration procedure, clicking Next at the end of each step.</p>	
<p>7 Select the reference impedance by pressing Reference Z and inputting a value from one ohm to one megohm.</p>	The impedance selected is shown at the top of the measurement screen.
<p>8 If you are using cables that were not calibrated in the probe calibration step, press I/Q Cable Calibrate..., follow the calibration procedure, and click Next at the end of each step.</p>	
<p>9 After completing the baseband IQ setup procedures, make your desired measurement.</p>	

3 Concepts

This chapter provides details about the DTMB (CTTB) broadcast systems, and explains how the various measurements are performed by the instrument. Suggestions for optimizing and troubleshooting your setup are provided, along with a list of related documents that are referenced for further information.

Introduction

DTMB (CTTB) concept information is split between these sections as follows:

1. A general introduction for DTMB (CTTB) Broadcast system, see [“What Is the DTMB \(CTTB\) Broadcast System?”](#) on page 43.
2. Key technologies used in DTMB (CTTB) system, such as FEC, Framing, TDS-OFDM, see [“Key Technologies”](#) on page 44.
3. Concepts and measurement methods for each measurement.
 - [“Channel Power Measurement Concepts”](#) on page 46.
 - [“Adjacent Channel Power \(ACP\) Measurement Concepts”](#) on page 48.
 - [“Power Statistics CCDF Measurement Concepts”](#) on page 50.
 - [“Spectrum Emission Mask Measurement Concepts”](#) on page 52.
 - [“Modulation Accuracy Measurement Concepts”](#) on page 56.
 - [“Monitor Spectrum Measurement Concepts”](#) on page 59.
 - [“IQ Waveform Measurement Concepts”](#) on page 60.
4. Concepts and measurement methods for baseband I/Q input, see [“Baseband I/Q Inputs \(Option BBA\) Measurement Concepts”](#) on page 61.
5. Other sources of measurement information is also given, see [“Other Sources of Measurement Information”](#) on page 66.
6. See [“References”](#) on page 67 for references used in this chapter.

What Is the DTMB (CTTB) Broadcast System?

Digital terrestrial multimedia broadcasting (DTMB), also known as CTTB (China Terrestrial Television Broadcasting), is the Chinese National Terrestrial Digital TV broadcasting Standard which was announced on August 18th, 2006 and implemented beginning August 1st, 2007. The full name of this national standard (GB20600-2006) is “Frame structure, channel coding and modulation for digital television terrestrial broadcasting system“.

The DTMB (CTTB) system performs the adaptation of the Digital Video signals from the output of the MPEG-2 multiplexer. A block diagram for typical DTMB (CTTB) system is shown in [Figure 3-1](#).

Figure 3-1

Block Diagram for DTMB (CTTB) System

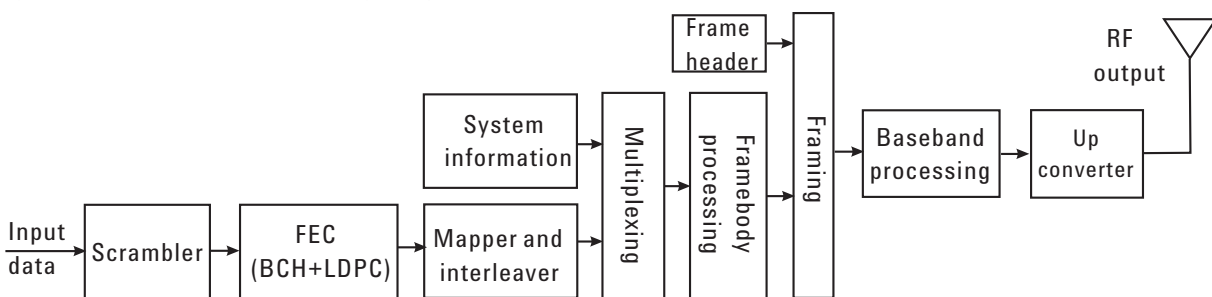

The input data first goes through a scrambler, Forward Error Correction (FEC) coding, bit-to-symbol mapping, and interleaving to form the basic data block. After that, the basic data block is multiplexed with system information and the data is processed to form the Frame Body (FB). Then, the signal frame, which is the combination of the FB and corresponding Frame Header (FH), is converted to baseband output signal through baseband processing (with in 8 MHz bandwidth). Finally, the RF output (within the VHF and UHF bands) is obtained after upconverting the baseband signal.

Briefly, the following processes are applied to the input data stream:

- Scrambler: randomization for energy dispersal
- FEC: concatenation of BCH and LDPC
- Mapping: 64QAM, 32QAM, 16QAM, 4QAM, 4QAM-NR
- Interleaving: time interleaving and frequency interleaving (only for C=3780)
- Framing and framebody data processing
- Baseband processing and Upconverter

The DTMB (CTTB) system has two transmission modes. One is C=1, in which mode, two pilots can be optionally inserted at ± 0.5 symbol rate into the framebody data after the signal frame is formed. The other one is C=3780 mode, in which mode, the carrier spacing is 2 kHz.

Refer to [\[1\]](#) for more details about DTMB (CTTB) broadcast system.

Key Technologies

FEC

DTMB (CTTB) system uses a concatenation of outer BCH and inner LDPC as the Forward Error Correction (FEC) code.

The BCH code is derived from BCH(1023, 1013). 261 zeros are added in front of the 752 information bits before BCH encoding, and then removed from the output of BCH encoder.

The LDPC has 3 inner code rate as shown in [Figure 3-1](#).

Table 3-1 LDPC code rates

Code Rate	Block Length (Bits)	Information Bit Length
0.4	7488	3008
0.6	7488	4512
0.8	7488	6016

Frame Structure

DTMB (CTTB) system takes a hierarchical frame structure, which includes:

- Calendar Day Frame (starting from 00:00:00 a.m. each day)
- Minute Frame: Lasts exactly 1 minute.
- Super Frame: Lasts 125 ms.
- Signal Frame: Consists of Frame Header (FH) and Frame Body (FB).

The frame structure is exactly synchronized with real-time, so it is easily to realize time synchronizations between different transmitters.

TDS-OFDM

Time-Domain Synchronous Orthogonal Frequency Division Multiplexing (TDS-OFDM) is a key technology in DTMB (CTTB). TDS-OFDM utilizes the known pseudorandom noise (PN) sequences as guard intervals (frame header). The PN sequences can serve as training symbols for synchronization and channel estimation purpose, so no additional pilot is needed. And high spectrum efficiency is also achieved. The signal frame structure using TDS-OFDM is shown in [Figure 3-2](#).

Figure 3-2 Signal Frame Structure for TDS-OFDM Symbols

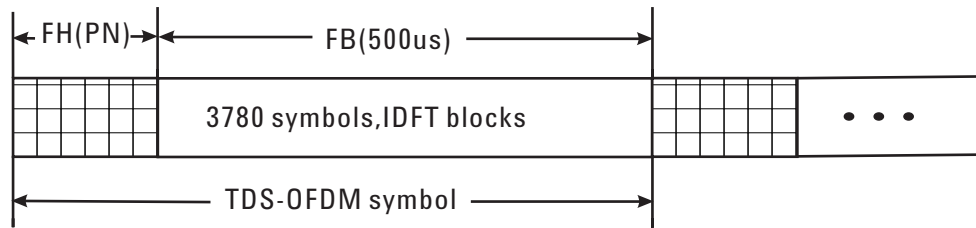

There are 3780 symbols in each FB including 3744 symbols carried data and 36 symbols carried the Transmission Parameter Signaling (TPS).

For the FH, there are three different construction mode.

- PN420. The construction is shown in Figure 3-3. The PN sequence used is PN255. The lengths for Pre-amble and Post-amble are 82 and 83 separately. The FH of this structure is rotated in each Super Frame.
- PN945. The construction is similar to that of PN420. The PN sequence used here is PN511. The lengths for Pre-amble and Post-amble are both 217.
- PN595. PN595 is generated by taking the first 595 bits from an M-sequence of 1023 bit-long.

Figure 3-3 The structure for PN420 and PN945

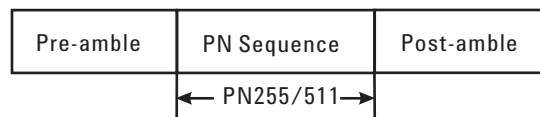

Channel Power Measurement Concepts

Purpose

The Channel Power measurement is an important test in digital video industry. It measures the in-channel power characteristics of DTMB (CTTB) transmitters. First of all, it measures the integrated power in the DTMB (CTTB) defined bandwidth. Secondly, it measures and reports the shoulder attenuation. Thirdly, it provides a view comparing the input signal against the DTMB (CTTB) defined spectrum mask under the condition of analog TV signal in adjacent channel.

Measurement Method

Channel Power measurement has three views. The measurement methods for each view are described as follows:

RF Spectrum

The Channel Power measurement reports the total transmitted power within the channel bandwidth (8 MHz for the DTMB (CTTB) mode). The integration bandwidth (IBW) method is used to determine the channel power.

Channel Power is a swept-frequency measurement allowing you to change the RBW and VBW settings manually. To improve repeatability, you can increase the number of averages. The channel power graph is shown in the graph window, while the absolute channel power in dBm and the mean power spectral density in dBm/Hz are shown in the text window.

Shoulder Attenuation

For shoulder attenuation measurements, the instrument first measures the power value at the center frequency f_c and $f_c \pm 4.2 \text{ MHz}$, then calculates the power difference between f_c and $f_c \pm 4.2 \text{ MHz}$. The smaller value is defined as shoulder attenuation.

The PASS/FAIL limit for shoulder attenuation is -36 dB when the device is a transmitter and -48 dB when the device is an exciter.[2][3]

Spectrum Mask

For the spectrum mask which is used to compare with the input signal, refer to Figure 3-4 and Table 3-2.[1]

Figure 3-4

Spectrum Mask for Analog TV Signal in an Adjacent Channel (Source: GB20600-2006)

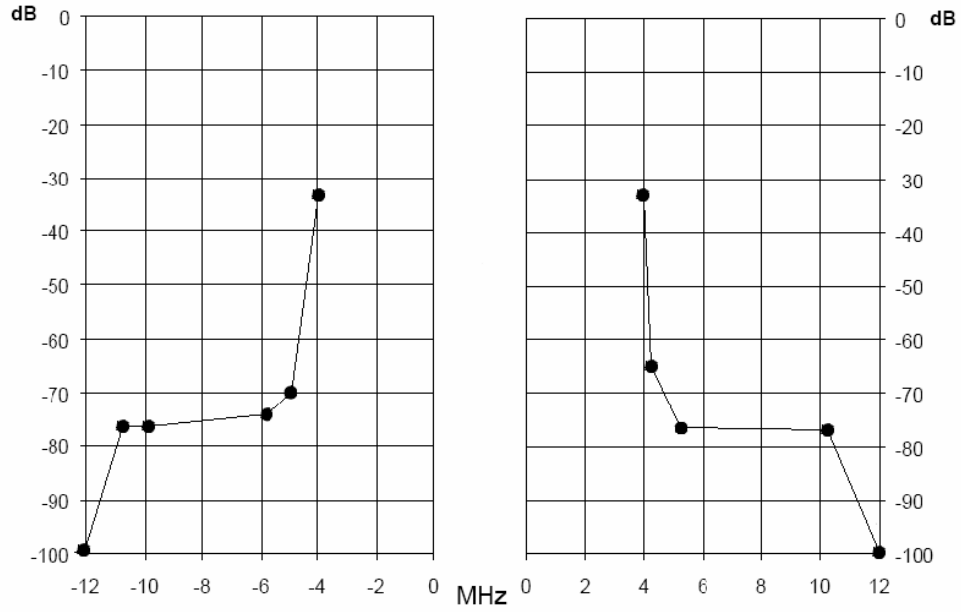

Table 3-2

Breakpoint in the Spectrum Mask

Frequency offset (MHz)	Relative Power level (dB)
-12	-100
-10.75	-76.9
-9.75	-76.9
-5.75	-74.2
-4.94	-69.9
-3.9	-32.8
+3.9	-32.8
+4.25	-64.9
+5.25	-76.9
+6.25	-76.9
+10.25	-76.9
+12	-100

Adjacent Channel Power (ACP) Measurement Concepts

Purpose

Adjacent Channel Power (ACP), as it applies to DTMB (CTTB), is the power contained in a specified frequency channel bandwidth relative to the total carrier power. It may also be expressed as a ratio of power spectral densities between the carrier and the specified offset frequency band.

As a measurement of out-of-channel emissions, ACP combines both in-band and out-of-band specifications to provide useful figures-of-merit for spectral regrowth and emissions produced by components and circuit blocks without the rigor of performing a full spectrum emissions mask measurement.

To maintain a quality transmission by avoiding channel interference, it is important to measure and reduce any adjacent channel leakage power transmitted from a DTMB (CTTB) transmitter. The characteristics of adjacent channel leakage power are mainly determined by the transmitter design, particularly the low-pass filter.

Measurement Method

The ACP measurement measures the power inside and outside the adjacent channel.

The measurement method and PASS/FAIL limit for the different device types (Transmitter/Exciter) when the bandwidth is 8 MHz are described in [Table 3-3](#).

In this measurement, three methods can be used to calculate power.

- **IBW (Integration BW):** The channel integration bandwidth is analyzed using the user defined resolution bandwidth (RBW), which is much narrower than the channel bandwidth.
- **Filter IBW:** This method is useful for improving dynamic range on the signal because a sharp cutoff band pass filter is used.
- **RBW:** This method uses zero-span and an appropriate RBW setting to capture the total power in the carrier channel and the offsets.

The default setting is IBW.

If **Total Pwr Ref** is selected as the measurement type, the results are displayed as relative power in dBc and as absolute power in dBm. If **PSD Ref** (Power Spectral Density Reference) is selected, the results are displayed as relative power in dB, and as absolute power in dBm/Hz.

Table 3-3 Device and Measurement Method in ACP Measurement

Measurement	Device	Measurement Method	PASS/FAIL Limit
ACP	Transmitter	<p>There are two measurement ranges: Inside Adjacent Channel and Outside Adjacent Channel.</p> <p>1. Inside Adjacent Channel:</p> <p>(1) Offset Frequency: ± 8 MHz</p> <p>(2) Offset Integ BW: 7.56 MHz</p> <p>(3) Result: the MAX value of the Lower and Upper Offset Abs/Rel Power</p> <p>2. Outside Adjacent Channel:</p> <p>(1) Offset Frequency:</p> <p>± 16 MHz, ± 24 MHz, ± 32 MHz</p> <p>(2) Offset Integ BW: 7.56 MHz</p> <p>(3) Result: the RMS value of the six Lower and Upper Offset Abs/Rel Power</p>	<p>Inside Adjacent Channel:</p> <p><i>Abs Limit</i> ≤ 13 mW and</p> <p><i>Rel Limit</i> ≤ -45 dB</p> <p>Outside Adjacent Channel:</p> <p><i>Abs Limit</i> ≤ 13 mW or</p> <p><i>Rel Limit</i> ≤ -60 dB</p>
	Exciter	<p>There is only one measurement range: Inside Adjacent Channel.</p> <p>Inside Adjacent Channel:</p> <p>(1) Offset Frequency: ± 8 MHz</p> <p>(2) Offset Integ BW: 7.56 MHz</p> <p>(3) Result: the MAX value of the Lower and Upper Offset Abs/Rel Power</p>	<p>Inside Adjacent Channel:</p> <p><i>Rel Limit</i> < -50 dB</p>

Power Statistics CCDF Measurement Concepts

Purpose

Many digitally modulated signals appear noise-like in the time and frequency domain. This means that statistical measurements of the signals can be a useful characterization. Power Complementary Cumulative Distribution Function (CCDF) curves characterize the higher-level power statistics of a digitally-modulated signal. The curves can be useful in determining design parameters for digital broadcast systems.

Peak-to-average power ratio is the ratio of the peak envelope power to the average envelope power of a signal. If the peak-to-average power ratio is small, the headroom required in the amplifier to prevent compression of the signal and interference with the adjacent frequency channels is small. Thus, the amplifier can operate more efficiently.

The power statistics CCDF measurement can be affected by many factors. For example, modulation filtering, modulation format, combining the multiple signals at different frequencies, number of active codes and correlation between symbols on different codes with spread spectrum systems. These factors are all related to modulation and signal parameters. External factors such as signal compression and expansion by non-linear components, group delay distortion from filtering, and power control within the observation interval also affect the measurement.

CCDF curves can help you in several situations:

- To determine the headroom required when designing a component.
- To confirm the power statistics of a given signal or stimulus. CCDF curves allow you to verify if the stimulus signal provided by another design team is adequate. For example, RF designers can use CCDF curves to verify that the signal provided by the digital signal processing (DSP) section is realistic.
- To confirm that a component design is adequate or to troubleshoot your subsystem or system design, you can make CCDF measurements at several points of a system.

Measurement Method

The power measured in power statistics CCDF curves is actually instantaneous envelope power defined by the equation:

$$P = (I^2 + Q^2)/Z_0$$

(where I and Q are the quadrature voltage components of the waveform and Z_0 is the characteristic impedance).

A CCDF curve is defined by how much time the waveform spends at or above a given power level. The percent of time the signal spends at or above the level defines the probability for that particular power level. To make the power statistics CCDF measurement, the instrument uses digital signal processing (DSP) to sample the input signal in the channel bandwidth.

The Gaussian distribution line as the band-limited gaussian noise CCDF reference line, the user-definable reference trace, and the currently measured trace can be displayed on a semi-log graph. If the currently measured trace is above the user reference trace, it means that the higher peak power levels against the average power are included in the input signal.

Spectrum Emission Mask Measurement Concepts

Purpose

Spectrum Emission Mask measurements include the in-band and out-of-band spurious emissions. As it applies to DTMB (CTTB), it is the power contained in a specified frequency bandwidth at certain offsets relative to the total carrier power. It is expressed as a ratio of power spectral densities between the carrier and the specified offset frequency band. To prevent interference from the DTMB (CTTB) transmitter, this measurement is needed in case of the television channels adjacent to other services (lower power or receive only).

Measurement Method

The spectrum emission mask measurement measures spurious signal levels in up to six pairs of offset/region frequencies and relates them to the carrier power. The reference channel integration bandwidth method is used to measure the carrier channel power. The spectrum mask used in this measurement can refer to the critical case in [Figure 3-5](#) and [Table 3-4](#).^[1]

The channel integration bandwidth is analyzed using the user defined resolution bandwidth (RBW), which is much narrower than the channel bandwidth. The measurement computes an average power of the channel or offset/region over a specified number of data acquisitions, automatically compensating for resolution bandwidth and noise bandwidth.

Figure 3-5

Spectrum Mask in Critical Cases (Source: GB20600-2006)

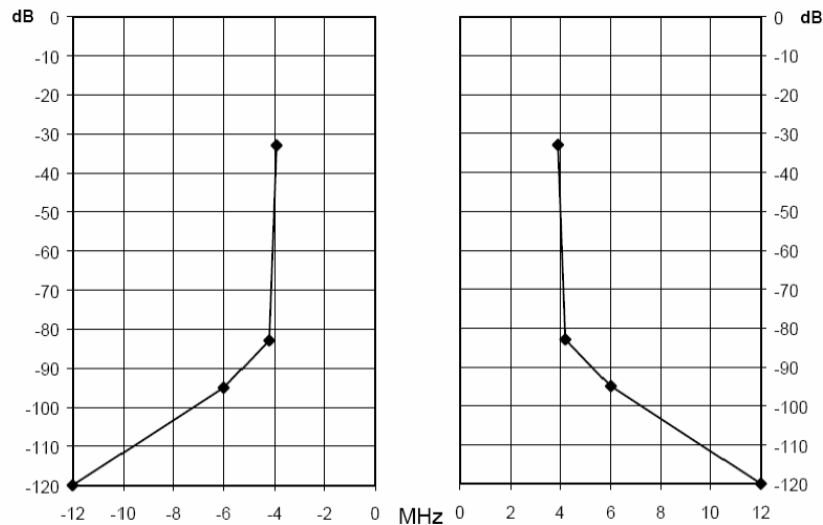

Table 3-4

Breakpoint in Spectrum Mask in Critical Cases

Frequency offset (MHz)	Relative Power level (dB)
-12	-120
-6	-95
-4.2	-83
-3.8	-32.8
+3.8	-32.8
+4.2	-83
+6	-95
+12	-120

Using Amplitude Correction in Spectrum Emission Mask Measurement

The dynamic range of the RF output of a real DTMB (CTTB) transmitter typically exceeds that of the analyzer, therefore, the direct measurement result is always “FAIL”, which does not reflect the real RF output.

To measure the spectrum emission mask of the transmitter’s RF output, there are two methods.

When the DTMB (CTTB) transmitter has an mask filter, the diagram for spectrum emission mask measurement is shown in [Figure 3-6](#).

Figure 3-6 Diagram for Spectrum Emission Mask Measurement on DTMB (CTTB) Transmitter

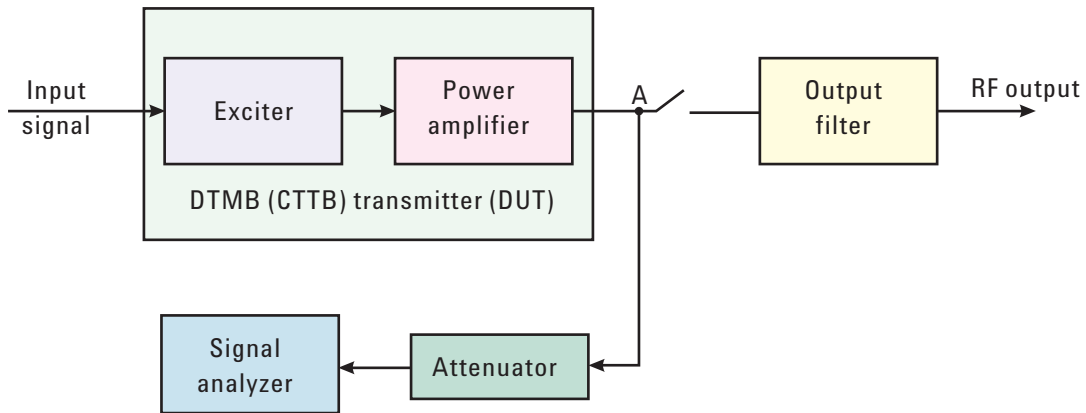

The steps for measuring the spectrum emission mask are as follows:

- a. Measure the frequency response of the output filter using a network analyzer or a combination of signal source and signal analyzer.
- b. Measure the signal transmitted at point A as shown in [Figure 3-6](#).
- c. Apply amplitude correction on spectrum value measured in step b using the filter’s response from step a.

The correction data is typically a table of the filter’s frequency response, in dB, at a number of frequency points across the band.

When the transmitter doesn’t have the output filter, an external filter with a band-block filter frequency response should be added after the transmitter for measurement arrangement as shown in [Figure 3-7](#).

Figure 3-7 Diagram for Spectrum Emission Mask Measurement on DTMB (CTTB) Transmitter without Output Filter

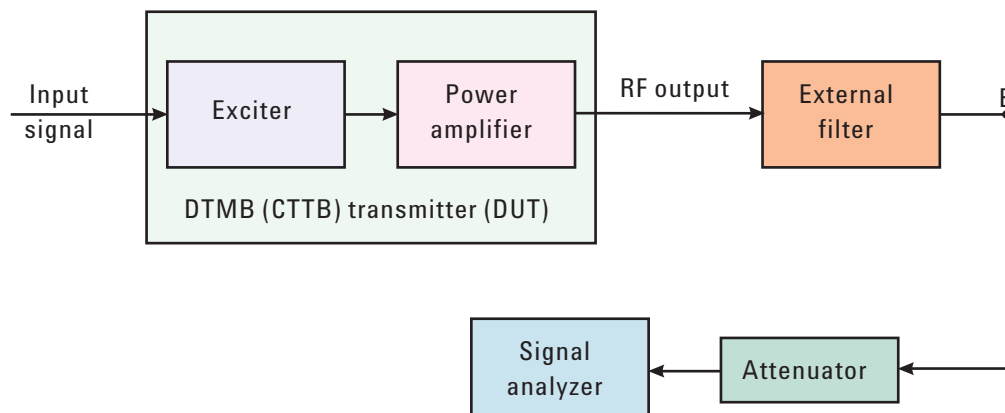

The steps for measuring the spectrum emission mask is as follows:

- a. Measure the frequency response of the external filter using a network analyzer or a combination of signal source and signal analyzer.
- b. Measure the signal transmitted at point B as shown in [Figure 3-7](#).
- c. Apply amplitude correction on spectrum value measured in step b using the filter's response from step a.

The correction data is typically a table of the negative of filter's frequency response, in dB, at a number of frequency points across the band.

Modulation Accuracy Measurement Concepts

Purpose

Measurement of modulation accuracy and quality are necessary to meet DTMB (CTTB) defined tests and ensure proper operation of the transmitters. This measurement takes into account all possible error mechanisms in the entire transmission chain including baseband filtering, I/Q modulation anomalies, filter amplitude and phase non-linearities, and power amplifier distortion. This provides an overall indication of the performance level of the transmitter.

Measurement Method

This procedure measures the performance of the transmitter's modulation circuitry.

In a digitally modulated signal, it is possible to predict what the ideal magnitude and phase of the carrier should be at any time, based on the transmitted data sequence. The transmitter's modulated signal is compared to an ideal signal vector. The difference between these two vectors is sampled and processed using DSP.

In the modulation accuracy measurement, the following data is provided:

- EVM - peak and rms error vector magnitude
- MER - distance between measured and theoretical constellation points
- Magnitude Error - rms magnitude error
- Phase Error - rms phase error
- Freq Error - the frequency difference between the transmitter's actual center frequency and the frequency (or channel) that you entered
- Quad Error - the orthogonal error between I and Q signals
- Amplitude Imbalance - a form of IQ gain imbalance

The detailed description of the parameters above is as follows:

EVM

EVM (Error Vector Magnitude) is a modulation quality metric widely used in digital broadcast systems. It is defined as:

$$EVM = \sqrt{\frac{\frac{1}{N} \sum_{i=1}^N (\delta I_j^2 + \delta Q_j^2)}{S_{max}^2}} \times 100\%$$

Where N is the number of data points in the measurement samples. S_{max} is the magnitude of the vector to the outermost state of the constellation.

NOTE This definition is only used in broadcast industry, and in wireless industry EVM is defined as the ratio of error vector vs. RMS reference vector.

$$EVM = \frac{\sqrt{\frac{1}{N} \sum_{j=1}^N (\delta I_j^2 + \delta Q_j^2)}}{S_{rms}} \times 100\%$$

S_{rms} is calculated in the following way: $S_{rms} = \sqrt{\frac{1}{N} \sum_{j=1}^N (I_j^2 + Q_j^2)}$

The representation of other definitions are expressed in [Figure 3-8](#).

Figure 3-8 Digital Demodulation Error

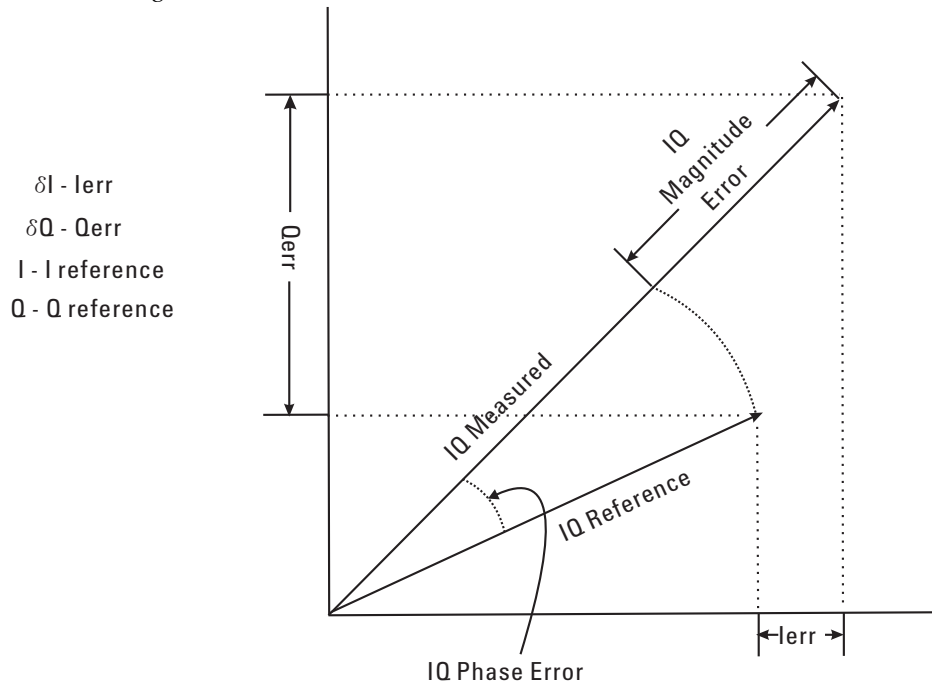

MER

MER (Modulation Error Ratio) is a power ratio expressed in dB of the sum of squares of the magnitude of the ideal symbol vectors to the sum of the squares of the magnitudes of the symbol error vectors.

The MER is calculated as below:

$$MER = 10 \log_{10} \left[\frac{\sum_{i=1}^N (I_j^2 + Q_j^2)}{\sum_{j=1}^N (\delta I_j^2 + \delta Q_j^2)} \right] dE$$

N is the number of data points in the measurement samples.

The representations of other definitions are expressed in [Figure 3-8](#).

Magnitude Error

Magnitude Error is the difference in amplitude between the I/Q measured signal and the I/Q reference signal which is shown in [Figure 3-8](#).

Phase Error

Phase error is the difference in phase between the I/Q measured signal and the I/Q reference signal. Phase Error is shown in [Figure 3-8](#).

Frequency Error

Frequency Error shows the signal carrier frequency-error relative to analyzer's center frequency. This parameter is displayed in Hz and is the amount of frequency shift, from the analyzer's center frequency, that the analyzer must perform to achieve carrier lock.

Errors in RF frequency, LO frequency, or digitizer clock rate could all appear as carrier frequency error.

Quad Error

Quad Error (Quadrature Skew Error) indicates the orthogonal error between the I and Q signals.

Ideally, I and Q should be orthogonal (90 degrees apart). A quadrature skew error of 3 degrees means I and Q are 93 degrees apart. A quadrature skew error of -3 degrees means I and Q are 87 degrees apart.

Amplitude Imbalance

Amplitude Imbalance is another form of IQ Gain imbalance. It is calculated from the formula below:

$$AI = 20 \log_{10} \frac{v_I}{v_Q} \text{ dB}$$

Where v_I and v_Q represent I and Q gain respectively.

Monitor Spectrum Measurement Concepts

Purpose

The monitor spectrum measurement provides spectrum analysis capability for the instrument. It is used as a quick, convenient means of looking at the entire spectrum. While the look and feel are similar to the Spectrum Analyzer mode, the functionality is greatly reduced for easy operation. The main purpose of the measurement is to show the spectrum. The default span should cover an appropriate frequency range of the application.

Measurement Method

The measurement takes the sweep and acquires the data between the start frequency and stop frequency, then trace is displayed in the measurement window.

Troubleshooting Hints

Changes to advanced spectrum settings, particularly to ADC range settings, can inadvertently result in spectrum measurements that are invalid and cause error messages to appear. Care needs to be taken when using advanced features.

IQ Waveform Measurement Concepts

Purpose

The waveform measurement is a generic measurement for viewing the input signal waveforms in the time domain. This measurement performs the zero span functionality found in traditional spectrum analyzers.

Basic mode waveform measurement data can be displayed using either a Signal Envelope window, or an I/Q window which shows the I and Q signal waveforms in parameters of voltage versus time. The advantage of having an I/Q view available while making a waveform measurement is that it allows you to view complex components of the same signal without changing settings or measurements.

The waveform measurement can be used to perform general purpose power measurements in the time domain with excellent accuracy.

Measurement Method

The instrument makes repeated power measurements at a set frequency, similar to the way a swept-tuned spectrum analyzer makes zero span measurements. The input analog signal is converted to a digital signal, which then is processed into a representation of a waveform measurement. The measurement relies on a high rate of sampling to create an accurate representation of a time domain signal.

Baseband I/Q Inputs (Option BBA) Measurement Concepts

The N9020A Option BBA Baseband I/Q Inputs provides the ability to analyze baseband I/Q signal characteristics of mobile and base station transmitters. This option may be used only in conjunction with the following modes:

- IQ Analyzer (Basic)
- 802.16 OFDMA (WiMAX/WiBro)
- cdma2000
- GSM/EDGE
- TD-SCDMA
- DTMB (CTTB)
- DVB-T/H with T2
- CMMB
- ISDB-T
- Digital Cable TV

What are Baseband I/Q Inputs?

Option BBA consists of a Baseband Input module, four input connectors, and a calibration output connector. The connectors are at the left side of the front panel. The two ports labeled “I” and “Q” are the “unbalanced” inputs.

An unbalanced or “single-ended” baseband measurement of an I or Q signal is made using a probe connected to the I or Q connector. A simultaneous I/Q unbalanced single-ended measurement may be made using two probes connected to the I and Q input connectors.

If “balanced” signals are available, they may be used to make a more accurate measurement. Balanced signals are signals present in two separate conductors, are symmetrical about ground, and are opposite in polarity, or out of phase by 180 degrees.

Measurements using balanced signals can have a higher signal to noise ratio resulting in improved accuracy. Noise coupled into each conductor equally in a “common mode” to both signals may be separated from the signal. The measure of this separation is “common-mode rejection”.

To make a balanced measurement, the two connectors labeled “I” and “Q” are used in conjunction with the I and Q inputs. The terms “I-bar” and “Q-bar” may be applied to the signals, as well as the inputs themselves. Probes (customer provided) must be used to input balanced baseband I/Q signals. This may be referred to as a balanced measurement.

Balanced baseband measurements are made using the I and I-bar connectors for I only signal measurements, while the Q and Q-bar connectors are used for a Q only signal measurement. Balanced measurements of I/Q require differential probe connections to all four input connectors. For details of probe selection and use, refer to [“Selecting Input Probes for Baseband Measurements”](#) on page 63.

What are Baseband I/Q Signals?

In transmitters, the term baseband I/Q refers to signals that are the fundamental products of individual I/Q modulators, before the I and Q component signals are combined, and before upconversion to IF or RF frequencies.

In receivers, baseband I/Q analysis may be used to test the I and Q products of I/Q demodulators, after an RF signal has been downconverted and demodulated.

Why Make Measurements at Baseband?

Baseband I/Q measurements are a valuable means of making qualitative analyses of the following operating characteristics:

- I/Q signal layer access for performing format-specific demodulation measurements (for example, DTMB (CTTB), DVB-T/H with T2, CDMA, GSM, W-CDMA).
- Modulation accuracy – that is, I/Q plane metrics:
 - error vector magnitude; rms, peak
 - frequency error
 - magnitude and phase errors
- CCDF of $I^2 + Q^2$
- Basic analysis of I and Q signals in isolation including: DC content, rms and peak to peak levels, CCDF of each channel

Comparisons of measurements made at baseband and RF frequencies produced by the same device are especially revealing. Once signal integrity is verified at baseband, impairments can be traced to specific stages of upconversion, amplification, or filtering by RF analysis. In addition, impairments to signal quality that are apparent at RF frequencies may be traceable to baseband using baseband analysis.

Selecting Input Probes for Baseband Measurements

The selection of baseband measurement probe(s) and measurement method is primarily dependent on the location of the measurement point in the circuit. The probe must sample voltages without imposing an inappropriate load on the circuit.

The system supports a variety of 1 M Ω impedance input passive probes as well as the Keysight 1153A active differential probe using the InfiniMax probe interface.

The Keysight 1153A active probe can be used for both single-ended and differential measurements. In either case a single connection is made for each channel (on either the I or Q input). The input is automatically configured to 50 Ω single-ended type measurement and the probe power is supplied through the InfiniMax interface. The probe can be configured for a variety of input coupling and low frequency rejection modes. In addition, a wide range of offset voltages and probe attenuation accessories are supported at the probe interface. The active probe has the advantage that it does not significantly load the circuit under test, even with unity gain probing.

With passive 1 M Ω probes, the probe will introduce a capacitive load on the circuit, unless a higher attenuation is used at the probe interface. Higher attenuation helps isolate the probe, however, it reduces the signal level and degrades the signal-to-noise-ratio of the measurement. Passive probes are available with a variety of attenuation values for a moderate cost. Many Keysight passive probes can be automatically identified by the system, setting the input impedance required as well as the nominal attenuation. For single-ended measurements a single probe is used for each channel. Other passive probes can be used, after manually setting the attenuation and probe impedance configurations.

For full differential measurements, the system supports probes on each of the four inputs. The attenuation for each of the probes should be the same for good common mode rejection and channel match.

Supported Probes

The following table lists the probes currently supported by Option BBA:

Probe Type	Model Number	Description
Active	1130A	1.5 GHz differential probe amp (No probe head)
	1131A ^a	InfiniMax 3.5 GHz probe
	1132A ^a	InfiniMax 5 GHz probe
	1133A ^a	InfiniMax 7 GHz probe
Passive	1161A	Miniature passive probe, 10:1, 10 M Ω , 1.5 m

- a. Probe heads are necessary to attach to your device properly. Probe connectivity kits such as the E2668A, E2669A or E2675A are needed. For more details, refer to the Keysight probe configuration guide, 5968-7141EN and 5989-6162EN.

Probes without Stored Calibration

The following 115xA active probes may be used with the MXA’s baseband IQ inputs and may use the same probe calibration utility software. However, the probe calibration data is not stored in the MXA and will be lost if power is cycled. Use of the E2655B de-skew and calibration kit, including the calibration fixture, is required because of the different physical configuration of the probes. (The physical connections are different mechanically, not electrically.)

Probe Type	Model Number	Description
Active	1153A	200MHz differential probe
	1156A	Active probe, 1.5 GHz
	1157A	Active probe, 2.5 GHz
	1158A	Active probe, 4 GHz

Refer to the current Keysight probe data sheet for specific information regarding frequency of operation and power supply requirements.

Baseband I/Q Measurement Views

Measurement result views made in the IQ Analyzer (Basic) mode are available for baseband signals if they relate to the nature of the signal itself. Many measurements which relate to the characteristics that baseband I and Q signals have when mixed and upconverted to signals in the RF spectrum can be made as well. However, measurements which relate to the characteristics of an upconverted signal that lie beyond the bandwidth available to the Baseband I/Q Input circuits can not be measured (the limits are dependent on the installed options: Standard – 10 Hz to 20 MHz, Option B25 – 10 Hz to 50 MHz, and Option S40 – 10 Hz to 80 MHz).

At RF frequencies, power measurements are conventionally displayed on a logarithmic vertical scale in dBm units, whereas measurements of baseband signals using Baseband I/Q inputs may be conveniently displayed as voltage using a linear vertical scale as well as a log scale.

Spectrum Views and 0 Hz Center Frequency

To view the Spectrum display of I only or Q only signals, use the Complex Spectrum measurement capability in IQ Analyzer (Basic) Mode.

I only and Q only Spectrum views are conventional, displayed with 0 Hz at the left side of the horizontal axis. When upconverted or multiplied, an I only or Q only signal could ultimately lie above or below the carrier center frequency, but in either case it will only occupy half the bandwidth.

Waveform Signal Envelope Views of I only or Q only

To view the Signal Envelope display of I only or Q only signals, use the Waveform measurement capability in IQ Analyzer (Basic) Mode.

The I and Q Waveform of an I/Q signal is very different from the complex signal displayed in the RF Envelope view. That is because the RF Envelope is a product of both the I and Q modulation waveforms.

However, an I and Q Waveform measurement of an I only or Q only signal is exactly the same signal displayed in the RF Envelope view. That is because an I only or Q only waveform determines the I only or Q only signal envelope. Thus, the RF Envelope view can be used to measure an I only or Q only waveform directly.

Other Sources of Measurement Information

Additional measurement application information is available through your local Keysight Technologies sales and service office. The following application notes treat digital communications measurements in much greater detail than discussed in this measurement guide.

- Application Note 1298
Digital Modulation in Communications Systems - An Introduction
Keysight part number 5965-7160E
- Application Note
Characterizing Digitally Modulated Signals with CCDF Curves
Keysight part number 5968-5858E

Go to http://www.keysight.com/find/digital_video to find more products and literatures on digital video transmitter and receiver measurements.

Instrument Updates at www.keysight.com

These web locations can be used to access the latest information about the instrument, including the latest firmware version.

<http://www.keysight.com/find/cxa>

<http://www.keysight.com/find/exa>

<http://www.keysight.com/find/mxa>

<http://www.keysight.com/find/pxa>

References

- [1] GB 20600-2006, Framing Structure, Channel Coding and Modulation for Digital Television Terrestrial Broadcasting system
- [2] GY/T 229.4-2008, Technical specifications and methods of measurement for digital terrestrial television broadcasting transmitters
- [3] GY/T 229.2-2008, Technical specifications and methods of measurement for digital terrestrial television broadcasting exciter