

# **Agilent N8829A 100GBASE-KR4 Compliance Test Application**

## **Methods of Implementation**



**Agilent Technologies**

# Notices

© Agilent Technologies, Inc. 2014

No part of this manual may be reproduced in any form or by any means (including electronic storage and retrieval or translation into a foreign language) without prior agreement and written consent from Agilent Technologies, Inc. as governed by United States and international copyright laws.

## Manual Part Number

Version 01.00.0000 or greater

## Edition

August 28, 2014

Available in electronic format only

Agilent Technologies, Inc.  
1900 Garden of the Gods Road  
Colorado Springs, CO 80907 USA

## Warranty

**The material contained in this document is provided “as is,” and is subject to being changed, without notice, in future editions. Further, to the maximum extent permitted by applicable law, Agilent disclaims all warranties, either express or implied, with regard to this manual and any information contained herein, including but not limited to the implied warranties of merchantability and fitness for a particular purpose. Agilent shall not be liable for errors or for incidental or consequential damages in connection with the furnishing, use, or performance of this document or of any information contained herein. Should Agilent and the user have a separate written agreement with warranty terms covering the material in this document that conflict with these terms, the warranty terms in the separate agreement shall control.**

## Technology Licenses

The hardware and/or software described in this document are furnished under a license and may be used or copied only in accordance with the terms of such license.

## Restricted Rights Legend

If software is for use in the performance of a U.S. Government prime contract or sub-contract, Software is delivered and licensed as “Commercial computer software” as defined in DFAR 252.227-7014 (June 1995), or as a “commercial item” as defined in FAR 2.101(a) or as “Restricted computer software” as defined in FAR 52.227-19 (June 1987) or any equivalent

agency regulation or contract clause. Use, duplication or disclosure of Software is subject to Agilent Technologies’ standard commercial license terms, and non-DOD Departments and Agencies of the U.S. Government will receive no greater than Restricted Rights as defined in FAR 52.227-19(c)(1-2) (June 1987). U.S. Government users will receive no greater than Limited Rights as defined in FAR 52.227-14 (June 1987) or DFAR 252.227-7015 (b)(2) (November 1995), as applicable in any technical data.

## Safety Notices

### CAUTION

A **CAUTION** notice denotes a hazard. It calls attention to an operating procedure, practice, or the like that, if not correctly performed or adhered to, could result in damage to the product or loss of important data. Do not proceed beyond a **CAUTION** notice until the indicated conditions are fully understood and met.

### WARNING

A **WARNING** notice denotes a hazard. It calls attention to an operating procedure, practice, or the like that, if not correctly performed or adhered to, could result in personal injury or death. Do not proceed beyond a **WARNING** notice until the indicated conditions are fully understood and met.

## 100GBASE-KR4 Compliance Test Application—At a Glance

The Agilent N8829A 100GBASE-KR4 Compliance Test Application is an Ethernet test solution that covers the electrical timing parameters for 100GBASE-KR4 specification (IEEE 802.3bj D3p0).

The 100GBASE-KR4 Compliance Test Application:

- Lets you select individual or multiple test to run.
- Lets you identify the device being tested and its configuration.
- Shows you how to make oscilloscope connections to the device under test.
- Automatically checks for proper oscilloscope configuration.
- Automatically sets up the oscilloscope for each test.
- Allows you to determine the number of trials for each test.
- Provides detailed information of each test that has been run. The result of maximum 64 worst trials can be displayed at any one time.
- Creates a printable HTML report of the tests that have been run. This report includes pass/fail limits, margin analysis, and screen shots.

### Required Equipment and Software

In order to run the 100GBASE-KR4 automated tests, you need the following equipment and software:

- For the minimum version of Infiniium oscilloscope software, see the N8829A release notes.
- N8829A 100GBASE-KR4 Compliance Test Application software and license.
- For differential probing (minimum 25 GHz):

### TIP

These can be used as an option, but will be BW limited. Instead, it is recommended to test with cables on the Real Edge channels.

- N2802A 25 GHz InfiniiMax III Series probe amplifier.
- N2803A 30 GHz InfiniiMax III Series probe amplifier.
- N2836A InfiniiMax III 26 GHz solder-in probe head.
- For single-ended probing:
  - SMA cables that are able to support the 25 Gb speed.
- Infiniium oscilloscope:
  - DSA-X 90000 Q-Series oscilloscope.
  - DSO-X 90000 Q-Series oscilloscope.



# Contents

100GBASE-KR4 Compliance Test Application—At a Glance	3
<b>1 Installing the N8829A Compliance Test Application</b>	
Installing the Software	8
Installing the License Key	9
<b>2 Preparing to Take Measurements</b>	
Calibrating the Oscilloscope	12
Starting the Compliance Test Application	13
<b>3 Main Voltage Measurements</b>	
Differential Peak-to-Peak Output Voltage Test with TX Disabled	17
DC Common Mode Output Voltage Test	18
AC Common Mode Output Voltage Test	19
Differential Peak-to-Peak Output Voltage Test	20
<b>4 Jitter and Data Rate Measurements</b>	
Data Rate	23
Jitter (Even-Odd Jitter, Bounded Uncorrelated Jitter, Random Jitter)	24
<b>5 Transmitter Output Waveform Measurements</b>	
Steady State Voltage Vf	27
Linear Fit Pulse Peak	28
<b>6 Transmitter Output Waveform - Normalized Coefficient Step Size Measurements</b>	
Normalized Coefficient Step Size c(1) inc c(0) hold c(-1) hold	31
Normalized Coefficient Step Size c(1) dec c(0) hold c(-1) hold	32
Normalized Coefficient Step Size c(1) hold c(0) inc c(-1) hold	33
Normalized Coefficient Step Size c(1) hold c(0) dec c(-1) hold	34
Normalized Coefficient Step Size c(1) hold c(0) hold c(-1) inc	35
Normalized Coefficient Step Size c(1) hold c(0) hold c(-1) dec	36

## 7 Transmitter Output Waveform - Full Scale Range Measurements

Minimum Pre-cursor Full-scale Test	39
Minimum Post-cursor Full-scale Test	40

## 8 Return Loss ENA/PNA Measurements

## 9 DME/EEE Waveform Measurements

DME Differential Peak-to-Peak Output Voltage Test	46
DME T1-Transition Position Spacing (Period) Test	47
DME T2-Clock Transition to Clock Transition Test	48
DME T3-Clock Transition to Data Transition Test	49
EEE Differential Peak-to-Peak Output Voltage Test with TX Disabled	50
EEE Differential Peak-to-Peak Output Voltage Test	51
EEE Common Mode Deviation Voltage Test	52

## 10 Debug Mode

### A Calibrating the Infiniium Oscilloscope and Probe

Oscilloscope Internal Calibration	56
Required Equipment for Oscilloscope Calibration	56
Running the Oscilloscope Internal Calibration	56
Probe Calibration	60
Required Equipment for Probe Calibration	60
Connecting the Probe for Calibration	60
Verifying the Connection	62
Running the Probe Calibration and Deskew	64
Verifying the Probe Calibration	66

## Index

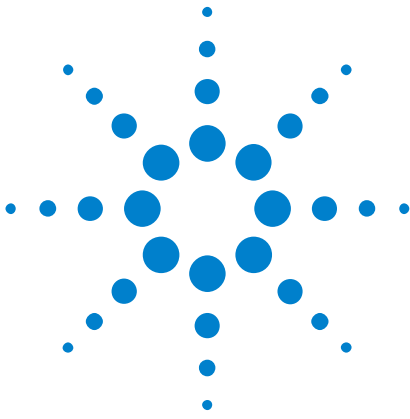

# 1 Installing the N8829A Compliance Test Application

Installing the Software 8

Installing the License Key 9

If you purchased the N8829A Compliance Test Application separate from your Infiniium oscilloscope, you need to install the software and license key.



## Installing the Software

- 1 Make sure you have the minimum version of Infiniium oscilloscope software (see the N8829A release notes) by choosing **Help > About Infiniium...** from the main menu.
- 2 To obtain the N8829A Compliance Test Application, go to Agilent website: "<http://www.agilent.com/find/N8829A>"
- 3 The link for N8829A 100GBASE-KR4 Compliance Test Application will appear. Double-click on it and follow the instructions to download and install the application software.



## Installing the License Key

- 1 Request a license code from Agilent by following the instructions on the Entitlement Certificate.  
  
You will need the oscilloscope's "Option ID Number", which you can find in the **Help > About Infiniium...** dialog.
- 2 After you receive your license code from Agilent, choose **Utilities > Install Option License...**
- 3 In the Install Option License dialog, enter your license code and click **Install License**.
- 4 Click **OK** in the dialog that tells you to restart the Infiniium oscilloscope application software to complete the license installation.
- 5 Click **Close** to close the Install Option License dialog.
- 6 Choose **File > Exit**.
- 7 Restart the Infiniium oscilloscope application software to complete the license installation.

## **1 Installing the N8829A Compliance Test Application**

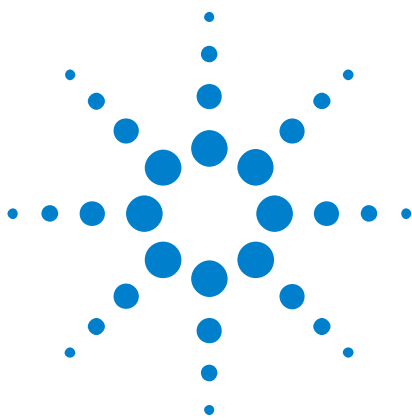

## 2 Preparing to Take Measurements

Calibrating the Oscilloscope 12

Starting the Compliance Test Application 13

Before running the automated tests, you should calibrate the oscilloscope and probe. No test fixture is required for this application. After the oscilloscope and probe have been calibrated, you are ready to start the N8829A Compliance Test Application and perform the measurements.



## Calibrating the Oscilloscope

If you haven't already calibrated the oscilloscope, see [Appendix A](#), “Calibrating the Infiniium Oscilloscope and Probe,” starting on page 55.

**NOTE**

If the ambient temperature changes more than 5 degrees Celsius from the calibration temperature, internal calibration should be performed again. The delta between the calibration temperature and the present operating temperature is shown in the **Utilities > Calibration** menu.

---

**NOTE**

If you switch cables between channels or other oscilloscopes, it is necessary to perform cable and probe calibration again. Agilent recommends that, once calibration is performed, you label the cables with the channel on which they were calibrated.

---

## Starting the Compliance Test Application

- 1 Ensure that the Device Under Test (DUT) is operating and set to desired test modes.
- 2 To start the Compliance Test Application: From the Infiniium oscilloscope's main menu, choose **Analyze > Automated Test Apps > N8829A 100GBASE-KR4 Test App**.

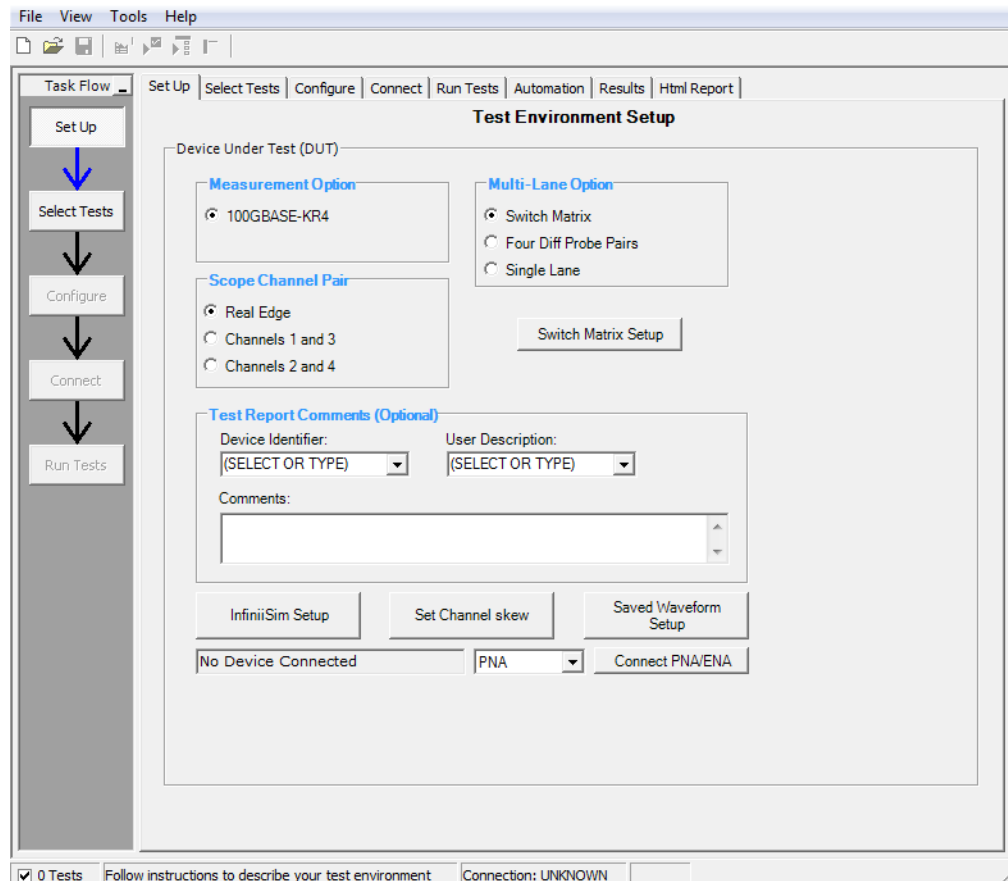
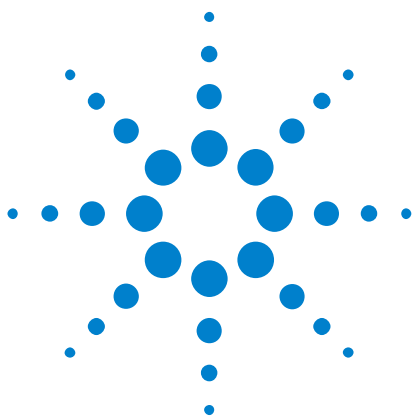

**Figure 1** N8829A Compliance Test Application Main Window

The task flow pane, and the tabs in the main pane, show the steps you take in running the automated tests:

## 2 Preparing to Take Measurements

<b>Set Up</b>	<p>Lets you identify and set up the test environment, including information about the device under test.</p> <p>The <b>Device Identifier</b>, <b>User Description</b>, and <b>Comments</b> are all printed in the final HTML report.</p> <p>Set up InfiniiSim with the <b>InfiniiSim Setup</b> button.</p> <p>With the <b>Set Channel skew</b> button, the channels can be visually adjusted and skewed.</p> <p>The <b>Saved Waveform Setup</b> button enables easy setup of saved waveforms. When waveforms are set up, the application will make all measurements on the saved waveforms.</p> <p>The <b>Multi-Lane Option</b> enables you to choose to test a single lane or with the switch matrix.</p>
<b>Select Tests</b>	<p>Lets you select the tests you want to run. The tests are organized hierarchically so you can select all tests in a group. After tests are run, status indicators show which tests have passed, failed, or not been run, and there are indicators for the test groups.</p>
<b>Configure</b>	<p>Lets you configure test parameters (for example, channels used in test, Number of UI to test, scope bandwidth, etc.).</p>
<b>Connect</b>	<p>Shows you how to connect the oscilloscope to the device under test for the tests that are to be run.</p>
<b>Run Tests</b>	<p>Starts the automated tests. If the connections to the device under test need to be changed while multiple tests are running, the tests pause, show you how to change the connection, and wait for you to confirm that the connections have been changed before continuing.</p>
<b>Automation</b>	<p>Lets you construct scripts of commands that drive execution of the application.</p>
<b>Results</b>	<p>Contains more detailed information about the tests that have been run. You can change the thresholds at which marginal or critical warnings appear.</p>
<b>HTML Report</b>	<p>Shows a compliance test report that can be printed.</p>



## 3 Main Voltage Measurements

Differential Peak-to-Peak Output Voltage Test with TX Disabled	17
DC Common Mode Output Voltage Test	18
AC Common Mode Output Voltage Test	19
Differential Peak-to-Peak Output Voltage Test	20

This section provides the Methods of Implementation (MOIs) for the 100GBASE-KR4 Main Voltage Measurements using an Agilent Infiniium oscilloscope and the N8829A Compliance Test Application.

### Probing and Connection for the Bus Signal Level Tests

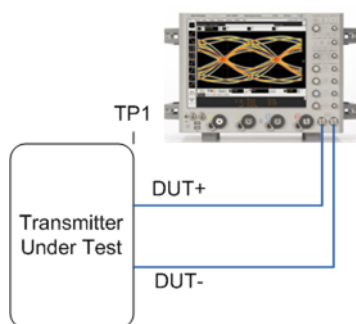

**Figure 2** Probing for Main Voltage Measurements

You can use any of the oscilloscope channels as the signal source channel; however, for proper BW, use the Real Edge channels. Select lane options in the **Setup** tab. You can identify the channels used for the measurement signal in the **Setup** tab of the Compliance Test Application.

- Test Procedure**
- 1 Start the automated test application as described in "[Starting the Compliance Test Application](#)" on page 13.
  - 2 Connect the probes to the signals on the DUT.
  - 3 Connect the oscilloscope probes or cables to the channel(s) of the oscilloscope that you have set up in the **Configuration** tab.
  - 4 In the Test application, click the **Set Up** tab. Select **Measurement Option**, **Lane Option**, and **Channels**.
  - 5 Set up Switch matrix (if used) by clicking on the **Switch Matrix Setup** button.

### 3 Main Voltage Measurements

- 6 Set up InfiniiSim if needed.
- 7 Type in or select the **Device Identifier** as well as the **User Description** from the drop-down list. Enter your comments in the **Comments** text box.
- 8 Click the **Select Tests** tab and check the tests you want to run. Check the parent node or group to check all the available tests within the group.

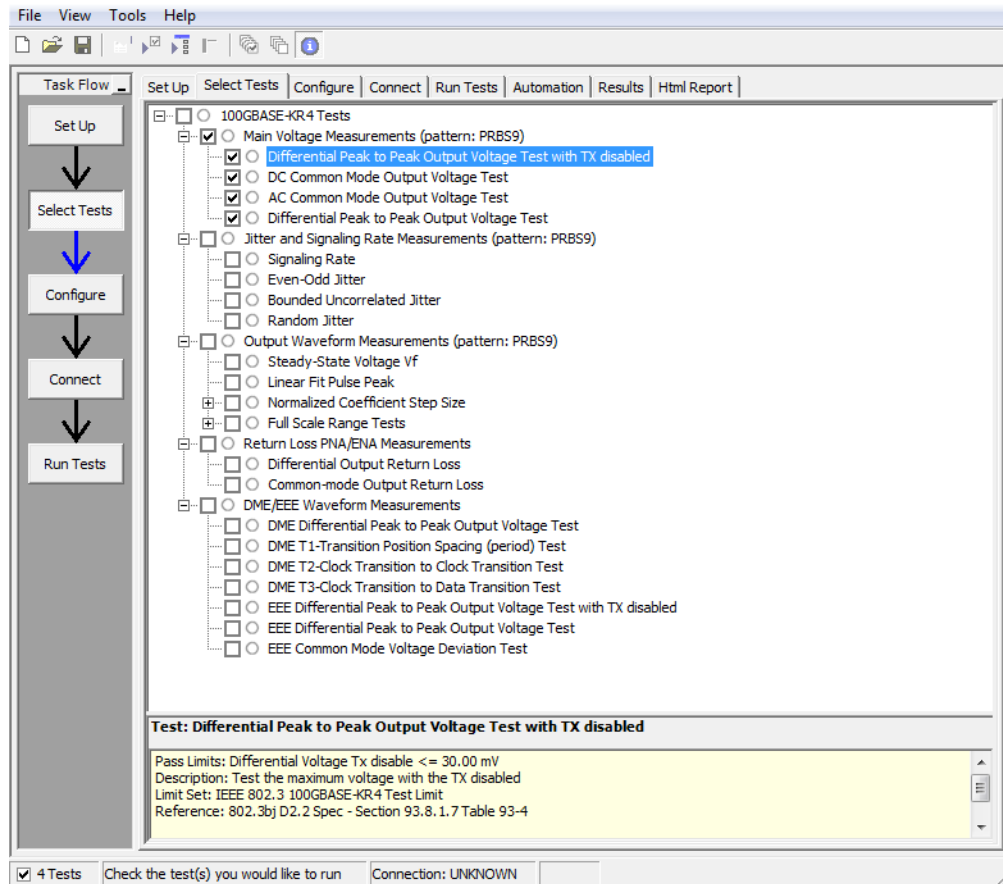

**Figure 3** Selecting Main Voltage Measurement Tests

#### Main Voltage Specifications

The 100GBASE-KR4 specifications can be found in IEEE 802.3 section 93.8.1.

- Differential Peak-to-Peak Output Voltage with TX disabled (max 30 mV).
- DC Common Mode Output Voltage (0- 1.9 V).
- AC Common Mode Output Voltage (max 12 mV).
- Differential Peak-to-Peak Output Voltage (max 1200 mV).



## Differential Peak-to-Peak Output Voltage Test with TX Disabled

The purpose of this test is to verify that when TX is disabled the peak-to-peak voltage is less than 30 mV.

**PASS Condition** The max peak-to-peak voltage is less than 30 mV.

- Measurement Algorithm**
- 1 Obtain sample or acquire signal data.
  - 2 Check that the signal is truly with TX disabled (no valid data transitions).
  - 3 Measure peak-to-peak voltage of the signal.
  - 4 Compare the max peak-to-peak voltage to 30 mV.

## DC Common Mode Output Voltage Test

The purpose of this test is to verify that the common mode signal of the differential pair is between 0- 1.9 V.

**NOTE**

This measurement can be done only with dual-single ended connection; it cannot be done with a differential probing connection.

---

**PASS Condition** The signal is between 0- 1.9 V.

**Measurement Algorithm**

- 1 Obtain sample or acquire signal data.
- 2 Verify that there is a signal and that the connection is dual-single ended.
- 3 Measure the peak-to-peak voltage of the addition of the channel 1 and 3 or channel 2 and 4.
- 4 Compare the voltage measurement to 0-1.9 V.

## AC Common Mode Output Voltage Test

The purpose of this test is to verify that the common mode signal of the differential pair rms voltage does not exceed 12 mV.

**NOTE**

This measurement can be done only with dual-single ended connection; it cannot be done with a differential probing connection.

---

**PASS Condition** The signal is less than 12 mV.

**Measurement Algorithm**

- 1 Obtain sample or acquire signal data.
- 2 Verify that there is a signal and that the connection is dual-single ended.
- 3 Measure the peak-to-peak voltage of the addition of the channel 1 and 3 or channel 2 and 4.
- 4 Compare the voltage measurement to 12 mV.

## Differential Peak-to-Peak Output Voltage Test

The purpose of this test is to verify that the peak-to-peak voltage of the differential signal on a PRBS9 pattern is less than 1200 mV.

**PASS Condition** The differential signal max peak to peak voltage on a PRBS9 pattern is less than 1200 mV.

- Measurement Algorithm**
- 1 Obtain sample or acquire signal data.
  - 2 Verify that there is a signal is connected and has a PRBS9 pattern.
  - 3 Measure the peak-to-peak voltage of the differential signal of DUT+ and DUT-.
  - 4 Compare the max peak-to-peak voltage to 1200 mV.

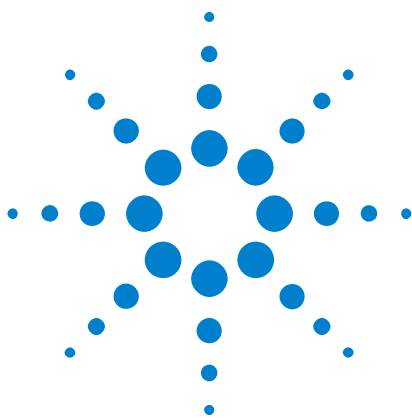

## 4 Jitter and Data Rate Measurements

Data Rate 23

Jitter (Even-Odd Jitter, Bounded Uncorrelated Jitter, Random Jitter) 24

This section provides the Methods of Implementation (MOIs) for the Jitter and Data Rate Measurements using an Agilent Infiniium oscilloscope and the N8829A 100GBASE-KR4 Compliance Test Application.

### Probing and Connection for the Bus Signal Level Tests

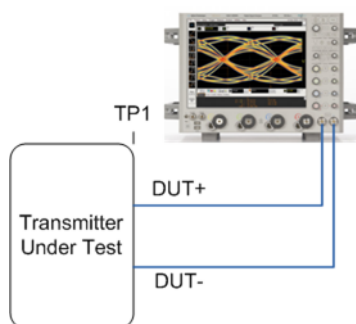

**Figure 4** Probing for Jitter and Data Rate Measurements

You can use any of the oscilloscope channels as the signal source channel; however, for proper BW, use the Real Edge channels. Select lane options in the **Setup** tab. You can identify the channels used for the measurement signal in the **Setup** tab of the Compliance Test Application.

- Test Procedure**
- 1 Start the automated test application as described in "[Starting the Compliance Test Application](#)" on page 13.
  - 2 Connect the probes to the signals on the DUT.
  - 3 Connect the oscilloscope probes or cables to the channel(s) of the oscilloscope that you have set up in the **Configuration** tab.
  - 4 In the Test application, click the **Set Up** tab. Select **Measurement Option**, **Lane Option**, and **Channels**.
  - 5 Set up Switch matrix (if used) by clicking on the **Switch Matrix Setup** button.
  - 6 Set up InfiniiSim if needed.

## 4 Jitter and Data Rate Measurements

- 7 Type in or select the **Device Identifier** as well as the **User Description** from the drop-down list. Enter your comments in the **Comments** text box.
- 8 Click the **Select Tests** tab and check the tests you want to run. Check the parent node or group to check all the available tests within the group.

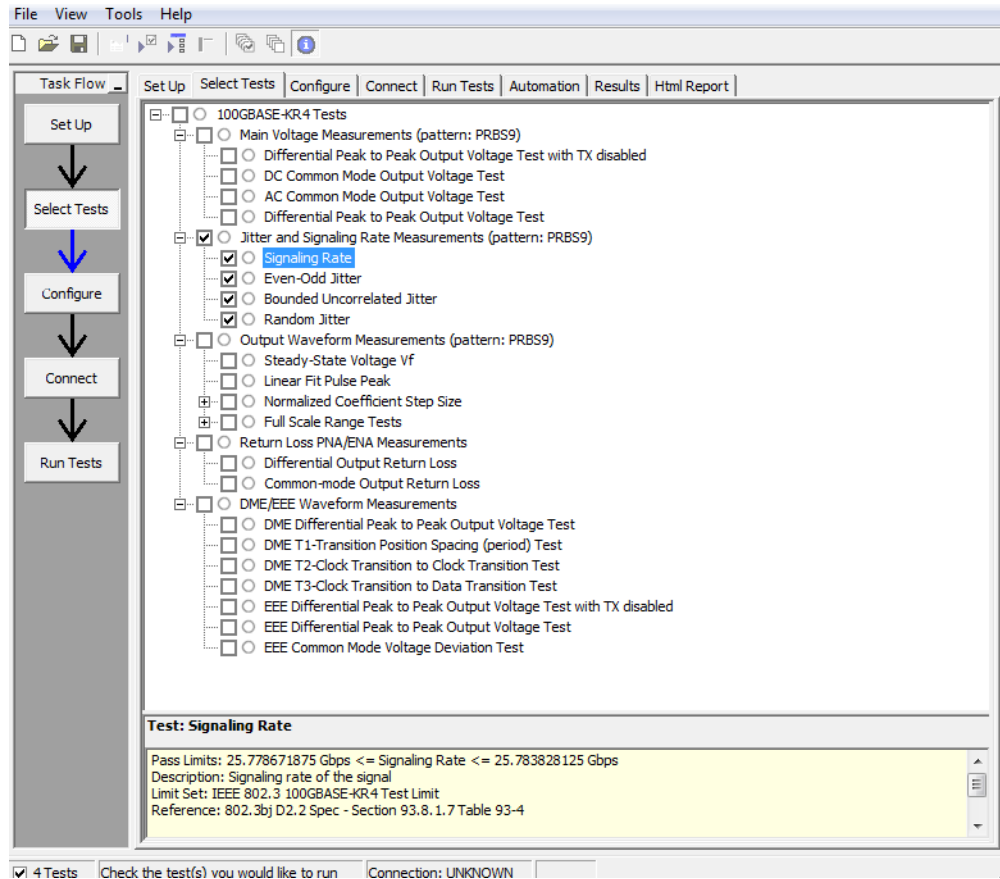

**Figure 5** Selecting Jitter and Data Rate Tests

### Transmitter Output Waveform Specifications

The 40GBASE-CR4 and 100GBASE-CR10 specifications can be found in IEEE 802.3 section 93.8.1.

- Data Rate (25.78125 +/- 100ppm GBd).
- Max output jitter.
  - Even-Odd Jitter (max 35 mUI).
  - Bounded Uncorrelated Jitter (max 100 mUI).
  - Random Jitter (max 10 mUI).

## Data Rate

The purpose of this test is to verify that the data rate mean is between  $25.78125 \pm 100$  ppm GBd.

**PASS Condition** The mean data rate is between  $25.78125 \pm 100$  ppm GBd.

- Measurement Algorithm**
- 1 Obtain sample or acquire signal data.
  - 2 Check that signal is connected and data pattern exists (PRBS9 must be used for this test).
  - 3 Set memory depth to capture the number or UI set in the configuration tab.
  - 4 Set data rate measurement to semi-automatic  $25.78125$  Gb/s.
  - 5 Measure min, max, mean data rate.
  - 6 Report min and max values.
  - 7 Compare and report the mean data rate value to  $25.78125 \pm 100$  ppm GBd.

### Jitter (Even-Odd Jitter, Bounded Uncorrelated Jitter, Random Jitter)

The purpose of this test is to verify that differential signal's Even-Odd Jitter is less than 35 mUI, Bounded Uncorrelated Jitter is less than 100 mUI, and Random Jitter is less than 10 mUI. If all tests are selected, all tests are run on a single measurement. Each test can be run individually by selecting any or some of the tests.

- PASS Conditions**
- Even-Odd Jitter is less than 35 mUI.
  - BUJ is less than 100 mUI.
  - Random Jitter rms is less than 10 mUI.

- Measurement Algorithm**
- 1 Obtain sample or acquire signal data.
  - 2 Check that signal is connected and data pattern exists (PRBS9 must be used for this test).
  - 3 Set memory depth to capture the number of UI set in the configuration tab.
  - 4 Set clock recovery to OJTF First Order PLL with Nominal Data Rate 25.78125 Gb/s and Loop Bandwidth to 10 MHz.
  - 5 Using EZJIT, measure Even-Odd Jitter, BUJ, and Rj at BER of 10E-12.
  - 6 Compare and report the values to their respective maximum specification.





## 5 Transmitter Output Waveform Measurements

Steady State Voltage  $V_f$  27

Linear Fit Pulse Peak 28

This section provides the Methods of Implementation (MOIs) for the Transmitter Output Waveform Measurements for Transition Time using an Agilent Infiniium oscilloscope and the N8829A 100GBASE-KR4 Compliance Test Application.

### Probing and Connection for the Bus Signal Level Tests

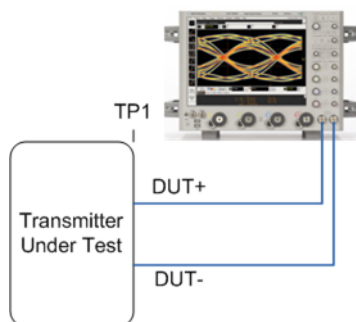

**Figure 6** Probing for Transmitter Output Waveform Measurements

You can use any of the oscilloscope channels as the signal source channel; however, for proper BW, use the Real Edge channels. Select lane options in the **Setup** tab. You can identify the channels used for the measurement signal in the **Setup** tab of the Compliance Test Application.

### Test Procedure

- 1 Start the automated test application as described in "[Starting the Compliance Test Application](#)" on page 13.
- 2 Connect the probes to the signals on the DUT.
- 3 Connect the oscilloscope probes or cables to the channel(s) of the oscilloscope that you have set up in the **Configuration** tab.
- 4 In the Test application, click the **Set Up** tab. Select **Measurement Option**, **Lane Option**, and **Channels**.



## 5 Transmitter Output Waveform Measurements

- 5 Set up Switch matrix (if used) by clicking on the **Switch Matrix Setup** button.
- 6 Set up InfiniiSim if needed.
- 7 Type in or select the **Device Identifier** as well as the **User Description** from the drop-down list. Enter your comments in the **Comments** text box.
- 8 Click the **Select Tests** tab and check the tests you want to run. Check the parent node or group to check all the available tests within the group.

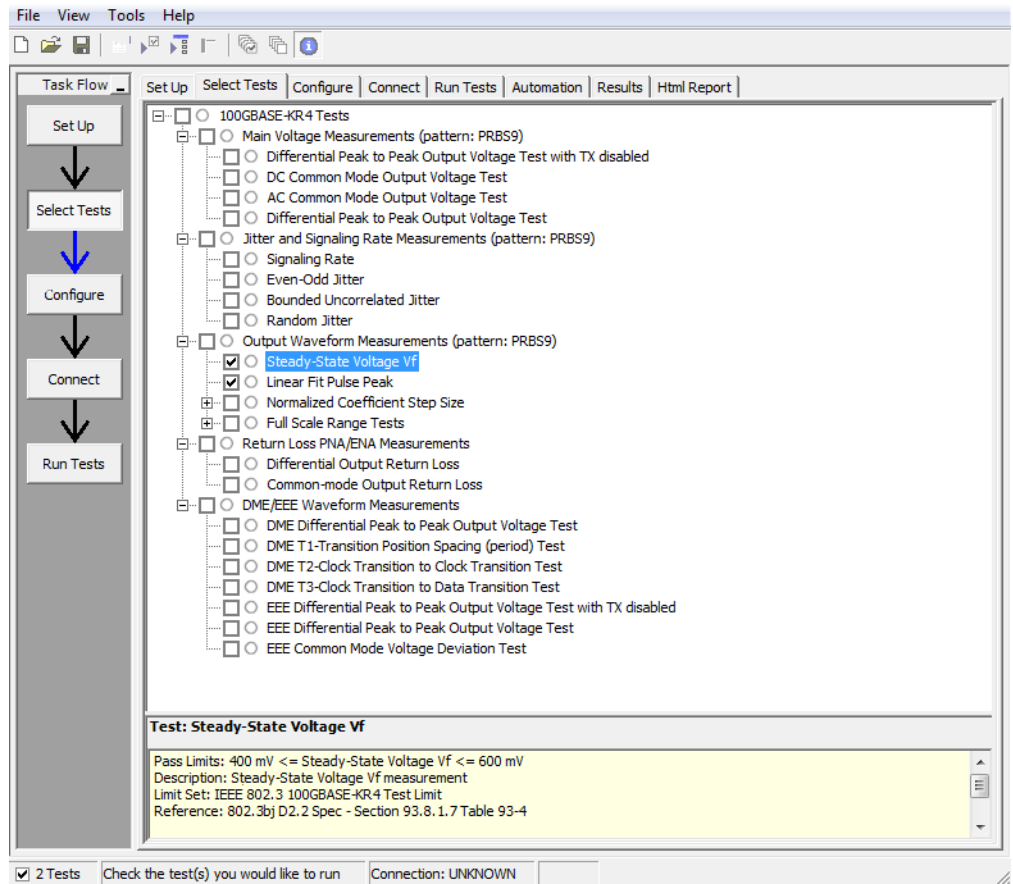

**Figure 7** Selecting Transmitter Output Waveform Test

### Transmitter Output Specifications

The 40GBASE-CR4 and 100GBASE-CR10 specifications can be found in IEEE 802.3 section 93.8.1.

- Steady State Voltage Vf (400-600 mV).
- Linear Fit Pulse Peak ( $0.71 * Vf$ ).

## Steady State Voltage $V_f$

The purpose of this test is to verify that the Steady State Voltage as described in section 85.8.3.3 is between 0.4 and 0.6 V.

**PASS Condition** The Steady State Voltage is between 0.4 and 0.6 V.

- Measurement Algorithm**
- 1 Check that signal is connected and the proper data pattern exists. (PRBS9 is required for this test).
  - 2 Set memory depth and sample rate to capture the 511 bits of the PRBS9 pattern for  $M = N_p + 1$  points per bit.
  - 3 Calculate  $V_f$  using the equations in section 85.8.3.3.5. The result value is the sum of the columns of P1 (Equ 85-9).
  - 4 Compare and report the result to 0.4-0.6 V.

## Linear Fit Pulse Peak

The purpose of this test is to verify that the Linear Fit Pulse as described in section 85.8.3.3 is greater than the  $V_f * 0.71$ .

**PASS Condition** The Linear Fit Pulse is greater than  $V_f * 0.71$ .

- Measurement Algorithm**
- 1 Check that signal is connected and the proper data pattern exists. (PRBS9 is required for this test).
  - 2 Set memory depth and sample rate to capture the 511 bits of the PRBS9 pattern for  $M = N_p + 1$  points per bit.
  - 3 Calculate Linear Fit Pulse using the equations in section 85.8.3.3.5. The result value read column wise from P1 (Equ 85-9).
  - 4 Compare and report the result to  $0.71 * V_f$ .

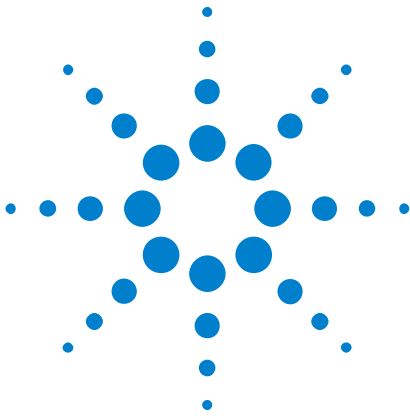

## 6 Transmitter Output Waveform - Normalized Coefficient Step Size Measurements

Normalized Coefficient Step Size c(1) inc c(0) hold c(-1) hold	31
Normalized Coefficient Step Size c(1) dec c(0) hold c(-1) hold	32
Normalized Coefficient Step Size c(1) hold c(0) inc c(-1) hold	33
Normalized Coefficient Step Size c(1) hold c(0) dec c(-1) hold	34
Normalized Coefficient Step Size c(1) hold c(0) hold c(-1) inc	35
Normalized Coefficient Step Size c(1) hold c(0) hold c(-1) dec	36

This section provides the Methods of Implementation (MOIs) for the Transmitter Output Waveform Normalized Coefficient Step Size Measurements using an Agilent Infiniium oscilloscope and the N8829A Compliance Test Application.

### Probing and Connection for the Bus Signal Level Tests

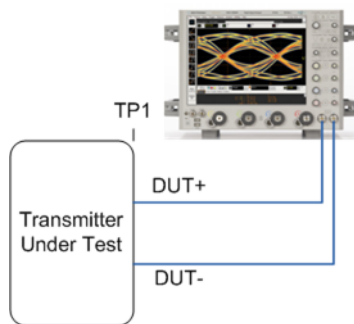

**Figure 8** Probing for Transmitter Output Waveform – Normalized Coefficient Step Size Measurements

You can use any of the oscilloscope channels as the signal source channel; however, for proper BW, use the Real Edge channels. Select lane options in the **Setup** tab. You can identify the channels used for the measurement signal in the **Setup** tab of the Compliance Test Application.

- Test Procedure**
- 1 Start the automated test application as described in "Starting the Compliance Test Application" on page 13.
  - 2 Connect the probes to the signals on the DUT.
  - 3 Connect the oscilloscope probes or cables to the channel(s) of the oscilloscope that you have set up in the **Configuration** tab.
  - 4 In the Test application, click the **Set Up** tab. Select **Measurement Option**, **Lane Option**, and **Channels**.
  - 5 Set up Switch matrix (if used) by clicking on the **Switch Matrix Setup** button.
  - 6 Set up InfiniiSim if needed.
  - 7 Type in or select the **Device Identifier** as well as the **User Description** from the drop-down list. Enter your comments in the **Comments** text box.
  - 8 Click the **Select Tests** tab and check the tests you want to run. Check the parent node or group to check all the available tests within the group.

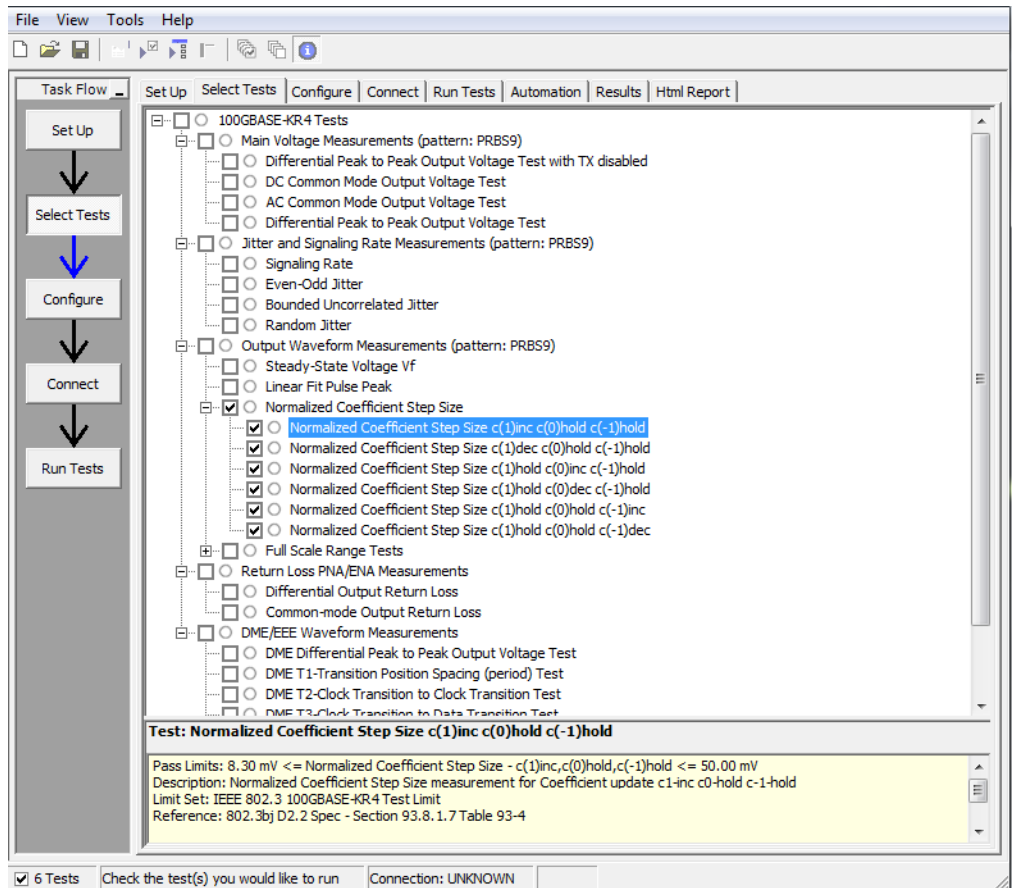

Figure 9 Selecting Transmitter Output Waveform – Normalized Coefficient Step Size Test

## Normalized Coefficient Step Size $c(1)$ inc $c(0)$ hold $c(-1)$ hold

The purpose of this test is to verify that the difference amplitude between coefficient updates falls between the specified values 0.0083 and 0.05.

**PASS Condition** The difference in the coefficient update when  $c(1)$  is incremented to the previous is within 0.0083 to 0.05.

- Measurement Algorithm**
- 1 Obtain sample or acquire signal data.
  - 2 Check that signal is connected and data pattern exists (PRBS9 pattern).
  - 3 Set memory depth to capture the number or UI set in the configuration tab.
  - 4 Request that DUT be initialized.
  - 5 Measure top/base amplitude (Amplitude1).
  - 6 Save result from step 5.
  - 7 Pop up to ask user to Increment  $c(1)$ . OK pressed.
  - 8 Measure top/base amplitude (Amplitude2).
  - 9 Subtract Amplitude2 – Amplitude1.
  - 10 Compare and report the values from step 9 to be in a range of 0.0083 to 0.05.

## Normalized Coefficient Step Size c(1) dec c(0) hold c(-1) hold

The purpose of this test is to verify that the difference in amplitude between the coefficient updates, falls between the specified values of -0.0083 to -0.05.

**PASS Condition** The difference in the coefficient update when c(1) is decremented to the previous is within -0.0083 to -0.05.

- Measurement Algorithm**
- 1 Obtain sample or acquire signal data.
  - 2 Check that signal is connected and data pattern exists (PRBS9 pattern).
  - 3 Set memory depth to capture the number or UI set in the configuration tab.
  - 4 If previous abs test has not been run, request that DUT be initialized, else do nothing.
  - 5 If previous abs test has not been run, measure top/base amplitude (Amplitude1), else Amplitude1 is equal to value of previous test Amplitude2.
  - 6 Save result from step 5.
  - 7 Pop up to ask user to Decrement c(1). OK pressed.
  - 8 Measure top/base amplitude (Amplitude2).
  - 9 Subtract Amplitude2 – Amplitude1.
  - 10 Compare and report the values from step 9 to be in a range of -0.0083 to -0.05.



## Normalized Coefficient Step Size $c(1)$ hold $c(0)$ inc $c(-1)$ hold

The purpose of this test is to verify that the difference in amplitude between the coefficient updates falls between the specified values of 0.0083 to 0.05.

**PASS Condition** The difference in the coefficient update when  $c(0)$  is incremented to the previous state is within 0.0083 to 0.05.

- Measurement Algorithm**
- 1 Obtain sample or acquire signal data.
  - 2 Check that signal is connected and data pattern exists (PRBS9 pattern).
  - 3 Set memory depth to capture the number or UI set in the configuration tab.
  - 4 If previous abs test has not been run, request that DUT be initialized, else do nothing.
  - 5 If previous abs test has not been run, measure top/base amplitude (Amplitude1), else Amplitude1 is equal to value of previous test Amplitude2.
  - 6 Save result from step 5.
  - 7 Pop up to ask user to Increment  $c(0)$ . OK pressed.
  - 8 Measure top/base amplitude (Amplitude2).
  - 9 Subtract Amplitude2 – Amplitude1.
  - 10 Compare and report the values from step 9 to be in a range of 0.0083 to 0.05.

## Normalized Coefficient Step Size $c(1)$ hold $c(0)$ dec $c(-1)$ hold

The purpose of this test is to verify that the difference in amplitude between the coefficient updates falls between the specified values of -0.0083 to -0.05.

**PASS Condition** The difference in the coefficient update when  $c(0)$  is decremented to the previous state is within -0.0083 and -0.05.

- Measurement Algorithm**
- 1 Obtain sample or acquire signal data.
  - 2 Check that signal is connected and data pattern exists (PRBS9 pattern).
  - 3 Set memory depth to capture the number or UI set in the configuration tab.
  - 4 If previous abs test has not been run, request that DUT be initialized, else do nothing.
  - 5 If previous abs test has not been run, measure top/base amplitude (Amplitude1), else Amplitude1 is equal to value of previous test Amplitude2.
  - 6 Save result from step 5.
  - 7 Pop up to ask user to Decrement  $c(0)$ . OK pressed.
  - 8 Measure top/base amplitude (Amplitude2).
  - 9 Subtract Amplitude2 – Amplitude1.
  - 10 Compare and report the values from step 9 to be in a range of -0.0083 to -0.05.

## Normalized Coefficient Step Size $c(1)$ hold $c(0)$ hold $c(-1)$ inc

The purpose of this test is to verify that the difference in amplitude between the coefficient updates falls between the specified values of 0.0083 to 0.05.

**PASS Condition** The difference in the coefficient update when  $c(-1)$  is incremented to the previous state is within 0.0083 and 0.05.

- Measurement Algorithm**
- 1 Obtain sample or acquire signal data.
  - 2 Check that signal is connected and data pattern exists (PRBS9 pattern).
  - 3 Set memory depth to capture the number or UI set in the configuration tab.
  - 4 If previous abs test has not been run, request that DUT be initialized, else do nothing.
  - 5 If previous abs test has not been run, measure top/base amplitude (Amplitude1), else Amplitude1 is equal to value of previous test Amplitude2.
  - 6 Save result from step 5.
  - 7 Pop up to ask user to Increment  $c(-1)$ . OK pressed.
  - 8 Measure top/base amplitude (Amplitude2).
  - 9 Subtract Amplitude2 – Amplitude1.
  - 10 Compare and report the values from step 9 to be in a range of 0.0083 to 0.05.

## Normalized Coefficient Step Size $c(1)$ hold $c(0)$ hold $c(-1)$ dec

The purpose of this test is to verify that the difference in amplitude between the coefficient updates falls between the specified values of -0.0083 to -0.05.

**PASS Condition** The difference in the coefficient update when  $c(-1)$  is decremented to the previous state is within -0.0083 and -0.05.

- Measurement Algorithm**
- 1 Obtain sample or acquire signal data.
  - 2 Check that signal is connected and data pattern exists (PRBS9 pattern).
  - 3 Set memory depth to capture the number or UI set in the configuration tab.
  - 4 If previous abs test has not been run, request that DUT be initialized, else do nothing.
  - 5 If previous abs test has not been run, measure top/base amplitude (Amplitude1), else Amplitude1 is equal to value of previous test Amplitude2.
  - 6 Save result from step 5.
  - 7 Pop up to ask user to Decrement  $c(-1)$ . OK pressed.
  - 8 Measure top/base amplitude (Amplitude2).
  - 9 Subtract Amplitude2 – Amplitude1.
  - 10 Compare and report the values from step 9 to be in a range of 0.0083 to 0.05.

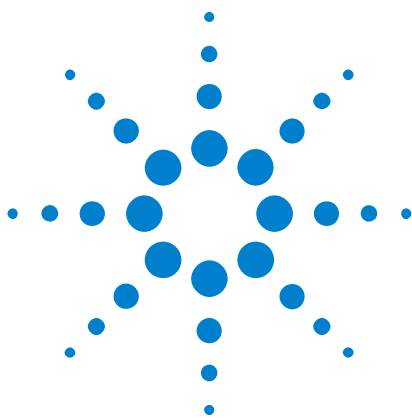

## 7 Transmitter Output Waveform - Full Scale Range Measurements

Minimum Pre-cursor Full-scale Test 39

Minimum Post-cursor Full-scale Test 40

This section provides the Methods of Implementation (MOIs) for the Transmitter Output Waveform Full-Scale Range Measurements using an Agilent Infiniium oscilloscope and the N8829A Compliance Test Application.

### Probing and Connection for the Bus Signal Level Tests

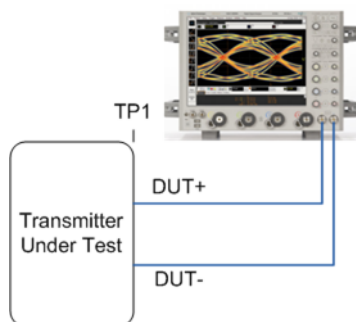

**Figure 10** Probing for Transmitter Output Waveform – Full Scale Range Measurements

You can use any of the oscilloscope channels as the signal source channel; however, for proper BW, use the Real Edge channels. Select lane options in the **Setup** tab. You can identify the channels used for the measurement signal in the **Setup** tab of the Compliance Test Application.

### Test Procedure

- 1 Start the automated test application as described in "[Starting the Compliance Test Application](#)" on page 13.
- 2 Connect the probes to the signals on the DUT.
- 3 Connect the oscilloscope probes or cables to the channel(s) of the oscilloscope that you have set up in the **Configuration** tab.
- 4 In the Test application, click on the **Set Up** tab. Select **Measurement Option**, **Lane Option**, and **Channels**.
- 5 Set up switch matrix (if used) by clicking the **Switch Matrix Setup** button.



## 7 Transmitter Output Waveform - Full Scale Range Measurements

- 6 Set up InfiniiSim if needed.
- 7 Type in or select the **Device Identifier** as well as the **User Description** from the drop-down list. Enter your comments in the **Comments** text box.
- 8 Click the **Select Tests** tab and check the tests you want to run. Check the parent node or group to check all the available tests within the group.

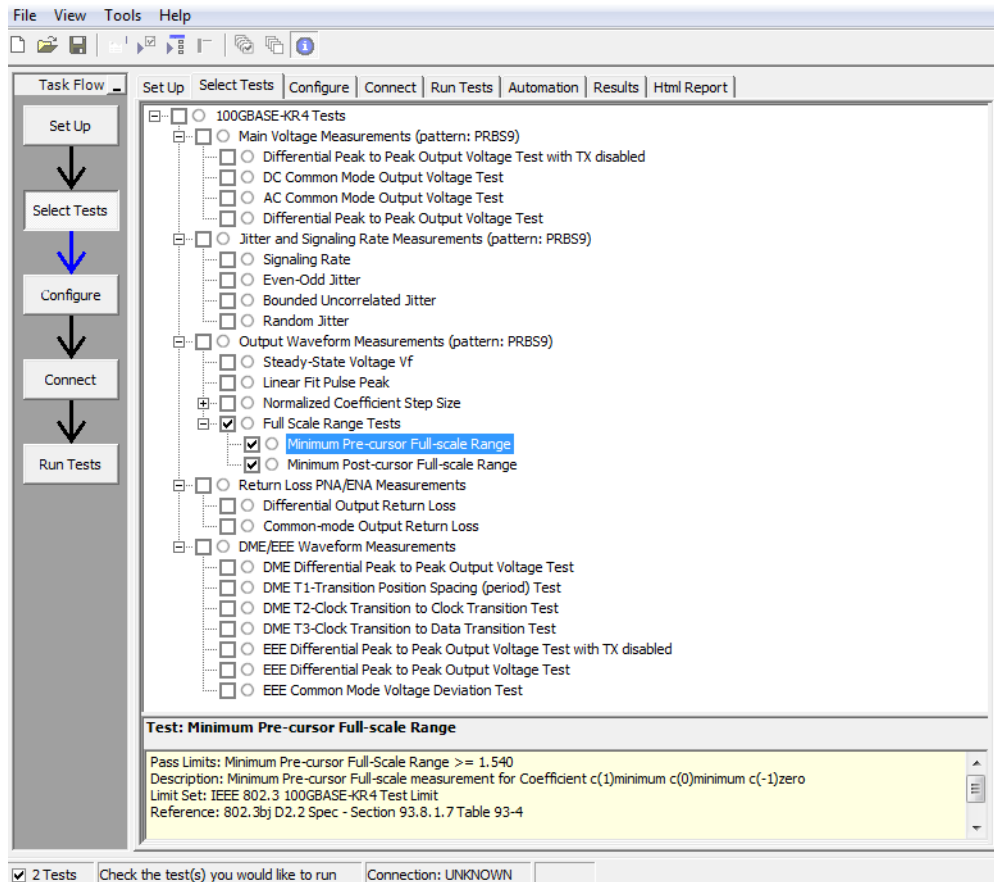

**Figure 11** Selecting Transmitter Output Waveform – Full Scale Range Tests

## Minimum Pre-cursor Full-scale Test

The purpose of this test is to verify that the minimum Pre-cursor is greater than or equal 1.54.

**PASS Condition** When the coefficients are set to c(1) zero c(0) minimum and c(-1) minimum, the pre-cursor full-scale ratio is greater than or equal 1.54.

- Measurement Algorithm**
- 1 Obtain sample or acquire signal data.
  - 2 Check that the signal is connected and data pattern exists (PRBS9 pattern).
  - 3 Set memory depth to capture the number or UI set in the configuration tab.
  - 4 Pop up to ask user to supply sufficient increment or decrement requests to set c(1) zero c(0) minimum and c(-1) minimum. OK pressed.
  - 5 Measure Vpreshoot and Vtop of the signal.
  - 6 Calculate the pre-cursor Vpreshoot/Vtop.
  - 7 Report and compare the value calculated in step 6 with 1.54.

## Minimum Post-cursor Full-scale Test

The purpose of this test is to verify that the minimum Post-cursor is greater than or equal to 4.

**PASS Condition** When the coefficients are set to  $c(1)$  minimum  $c(0)$  minimum and  $c(-1)$  zero, the post-cursor full-scale ration is greater than or equal to 4.

- Measurement Algorithm**
- 1 Obtain sample or acquire signal data.
  - 2 Check that the signal is connected and data pattern exists (PRBS9 pattern).
  - 3 Set memory depth to capture the number or UI set in the configuration tab.
  - 4 Pop up to ask user to supply sufficient increment or decrement requests to set  $c(1)$  zero  $c(0)$  minimum and  $c(-1)$  minimum. OK pressed.
  - 5 Measure  $V_{\text{Overshoot}}$  and  $V_{\text{top}}$  of the signal.
  - 6 Calculate the pre-cursor  $V_{\text{Overshoot}}/V_{\text{top}}$ .
  - 7 Report and compare the value calculated in step 6 with 4.





## 8 Return Loss ENA/PNA Measurements

This section provides the Methods of Implementation (MOIs) for the Return Loss Measurements using an Agilent Infiniium oscilloscope, PNA or ENA, and the N8829A Compliance Test Application. The Compliance test application controls the PNA/ENA to set the test limits and run the test. The calibration must be done on the PNA/ENA.

- Test Procedure**
- 1 Start the automated test application as described in "[Starting the Compliance Test Application](#)" on page 13.
  - 2 Calibrate the PNA or ENA.
  - 3 In the Test application, click on the **Set Up** tab. Select **Measurement Option**, **Lane Option**, and **Channels**.
  - 4 Set up switch matrix (if used) by clicking the **Switch Matrix Setup** button.
  - 5 Type in or select the **Device Identifier** as well as the **User Description** from the drop-down list. Enter your comments in the **Comments** text box.
  - 6 Click the **Select Tests** tab and check the tests you want to run. Check the parent node or group to check all the available tests within the group.
  - 7 Press **Run**. The test limits are automatically calculated.



## 8 Return Loss ENA/PNA Measurements

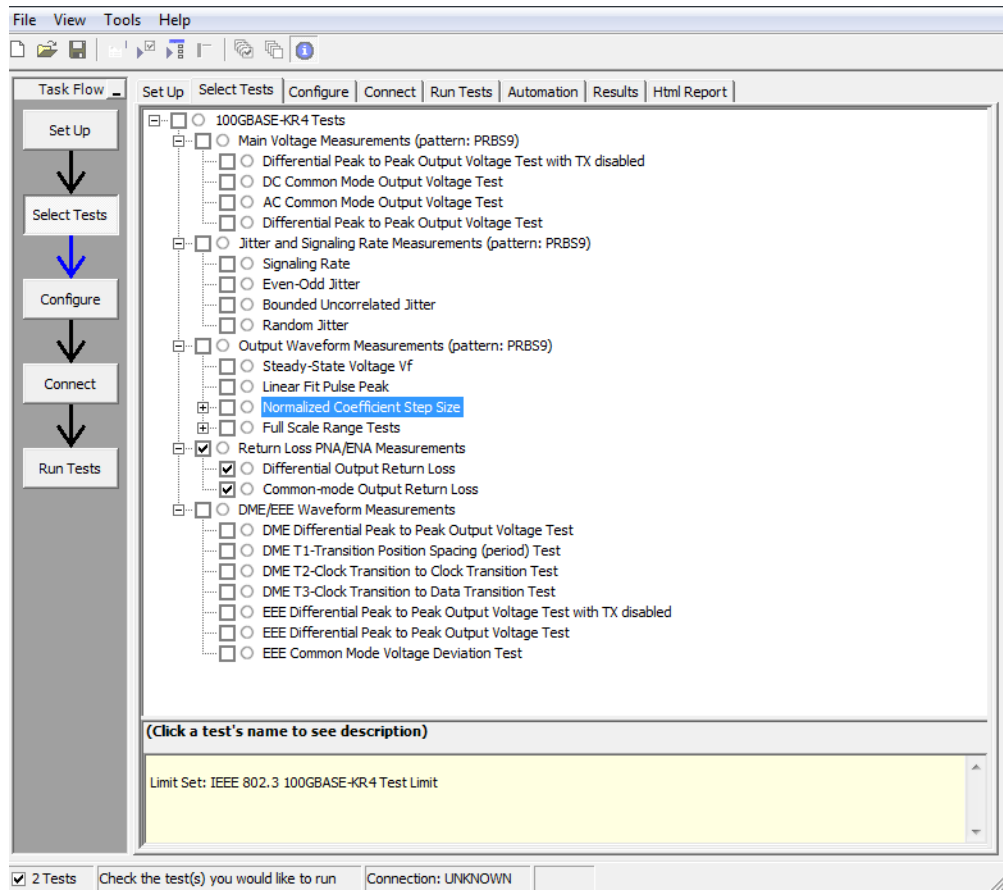
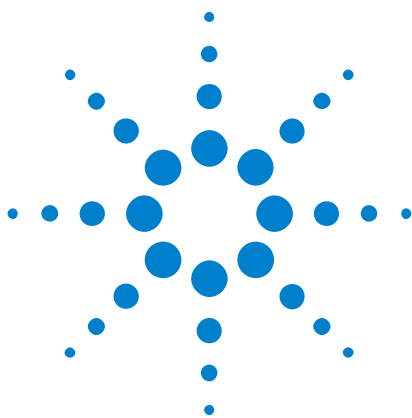

Figure 12 Selecting Return Loss Measurement



## 9 DME/EEE Waveform Measurements

DME Differential Peak-to-Peak Output Voltage Test	46
DME T1-Transition Position Spacing (Period) Test	47
DME T2-Clock Transition to Clock Transition Test	48
DME T3-Clock Transition to Data Transition Test	49
EEE Differential Peak-to-Peak Output Voltage Test with TX Disabled	50
EEE Differential Peak-to-Peak Output Voltage Test	51
EEE Common Mode Deviation Voltage Test	52

This section provides the Methods of Implementation (MOIs) for the DME and EEE Waveform Measurements using an Agilent Infiniium oscilloscope and the N8829A Compliance Test Application.

### Probing and Connection for the Bus Signal Level Tests.

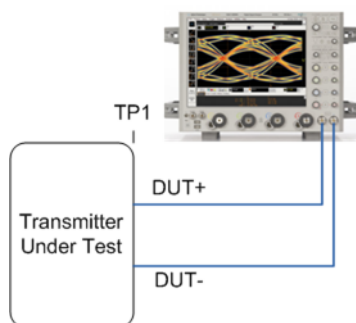
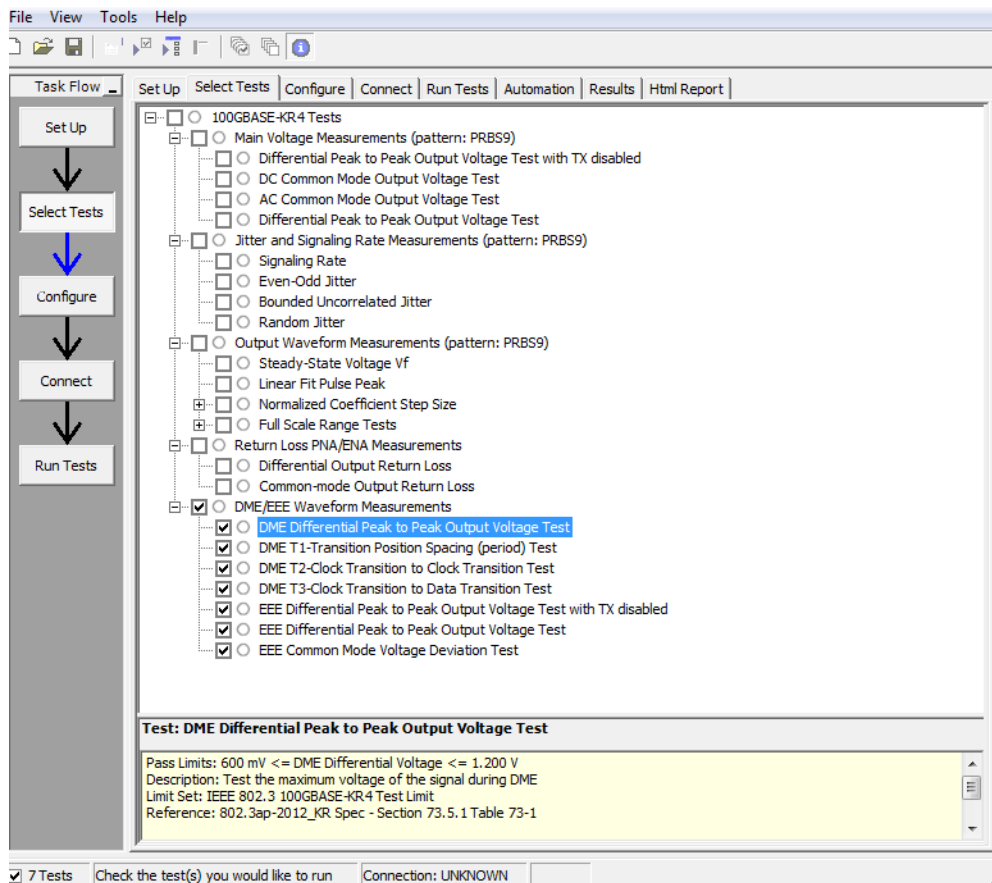

**Figure 13** Probing for DME/EEE Waveform Measurements

You can use any of the oscilloscope channels as the signal source channel; however, for proper BW, use the Real Edge channels. Select lane options in the **Setup** tab. You can identify the channels used for the measurement signal in the **Setup** tab of the Compliance Test Application.

- Test Procedure**
- 1 Start the automated test application as described in "[Starting the Compliance Test Application](#)" on page 13.
  - 2 Connect the probes to the signals on the DUT.
  - 3 Connect the oscilloscope probes or cables to the channel(s) of the oscilloscope that you have set up in the **Configuration** tab.

- 4 In the Test application, click the **Set Up** tab. Select **Measurement Option**, **Lane Option**, and **Channels**.
- 5 Set up Switch matrix (if used) by clicking on the **Switch Matrix Setup** button.
- 6 Set up InfiniiSim if needed.
- 7 Type in or select the **Device Identifier** as well as the **User Description** from the drop-down list. Enter your comments in the **Comments** text box.
- 8 Click the **Select Tests** tab and check the tests you want to run. Check the parent node or group to check all the available tests within the group.



**Figure 14** Selecting DME/EEE Waveform Tests

**DME/EEE Waveform Specifications**

The 10GBASE-KR DME specifications can be found in IEEE 802.3ap section 73.5.1 Table 73-1 and section 73.5.3 Table 73-2. The 10GBASE-KR EEE specifications can be found in section 72.7.1 Table 72-6.

- DME Differential Peak-to-Peak Output Voltage (0.6-1.2 V).
- DME T1 (3.2 ns-0.01% to 3.2 ns+0.1%).

- DME T2 (6.2 ns-6.6 ns).
- DME T3 (3.0 ns-3.4 ns).
- EEE Differential Peak-to-Peak Output Voltage with TX disabled (max 30 mV).
- EEE Differential Peak-to-Peak Output Voltage with TX enabled (min 120 mV).
- EEE Common Mode Voltage Deviation ( $\pm 150$  mV).

## DME Differential Peak-to-Peak Output Voltage Test

The purpose of this test is to verify that the peak-to-peak voltage of the differential signal on a 1010 pattern is less than 1200 mV.

**PASS Condition** The differential signal max peak-to-peak voltage on a 1010 pattern is less than 1200 mV.

- Measurement Algorithm**
- 1 Obtain sample or acquire signal data.
  - 2 Verify that there is a signal is connected and has a 1010 pattern.
  - 3 Measure the peak-to-peak voltage of the differential signal of DUT+ and DUT-.
  - 4 Compare the min and max peak-to-peak voltage to be within 0.6 to 1.2 V.

## DME T1-Transition Position Spacing (Period) Test

The purpose of this test is to verify that transition spacing of the DME signal is 3.2 ns  $\pm$ 0.01%.

**PASS Condition** The mean period is between 3.2 ns  $\pm$ 0.01%.

- Measurement Algorithm**
- 1 Obtain sample or acquire signal data.
  - 2 Verify that there is a signal is connected.
  - 3 Set memory depth to capture the number or UI set in the configuration tab.
  - 4 Request DUT in DME mode.
  - 5 Measure the unit interval of the differential DME signal – set UI measurement to SEMI, 3.2e-9.
  - 6 Compare the mean measurement to 3.2 ns  $\pm$ 0.01%.

## DME T2-Clock Transition to Clock Transition Test

The purpose of this test is to verify clock to clock transition is 6.2 ns to 6.6 ns.

**PASS Condition** The mean period is between 6.2 ns to 6.6 ns.

- Measurement Algorithm**
- 1 Obtain sample or acquire signal data.
  - 2 Verify that there is a signal is connected.
  - 3 Set memory depth to capture the number or UI set in the configuration tab.
  - 4 Request DUT in DME mode.
  - 5 Measure the rising to rising edge.
  - 6 Compare the min and max values to measurement to 6.2 ns to 6.6 ns.



## DME T3-Clock Transition to Data Transition Test

The purpose of this test is to verify clock to data transition is 3.0 ns to 3.4 ns.

**PASS Condition** The min and max UI time is between 3.0 ns to 3.4 ns.

- Measurement Algorithm**
- 1 Obtain sample or acquire signal data.
  - 2 Verify that there is a signal is connected.
  - 3 Set memory depth to capture the number or UI set in the configuration tab.
  - 4 Request DUT in DME mode.
  - 5 Measure the unit interval of the differential DME signal – set UI measurement to SEMI, 3.2e-9.
  - 6 Compare the min and max values to measurement to 3.0 ns to 3.4 ns.

## EEE Differential Peak-to-Peak Output Voltage Test with TX Disabled

The purpose of this test is to verify that when TX is disabled the peak-to-peak voltage is less than 30 mV.

**PASS Condition** The max peak-to-peak voltage is less than 30 mV.

- Measurement Algorithm**
- 1 Obtain sample or acquire signal data.
  - 2 Request DUT to be EEE mode.
  - 3 Check that the signal is truly with TX disabled (no valid data transitions).
  - 4 Measure peak-to-peak voltage of the signal.
  - 5 Compare the max peak-to-peak voltage to 30 mV.

## EEE Differential Peak-to-Peak Output Voltage Test

The purpose of this test is to verify that the peak-to-peak voltage of the differential signal on a 1010 pattern is greater or equal to 720 mV.

**PASS Condition** The differential signal max peak-to-peak voltage on a 1010 pattern is greater than or equal to 720 mV.

- Measurement Algorithm**
- 1 Obtain sample or acquire signal data.
  - 2 Request DUT in EEE mode.
  - 3 Verify that there is a signal is connected and has a 1010 pattern.
  - 4 Measure the peak-to-peak voltage of the differential signal of DUT+ and DUT-.
  - 5 Compare the min voltage to be greater than or equal to 720 mV.

## EEE Common Mode Deviation Voltage Test

The purpose of this test is to verify that the common mode signal of the differential pair of the pre-LPI signal and the LPI signal is within  $\pm 150$  mV.

**PASS Condition** The signal voltage change between pre and post LPI is within 150 mV change.

- Measurement Algorithm**
- 1 Obtain sample or acquire signal data.
  - 2 Verify that there is a signal and that the connection is dual-single ended.
  - 3 Request DUT to be pre-LPI.
  - 4 Measure the peak-to-peak voltage of the addition of the channel 1 and 3 or channel 2 and 4.
  - 5 Request DUT to be in LPI.
  - 6 Measure the peak-to-peak voltage of the addition of the channel 1 and 3 or channel 2 and 4.
  - 7 Calculate  $V_{pp}(\text{post}) - V_{pp}(\text{pre})$ .
  - 8 Compare the result from step 7 to  $\pm 150$  mV.

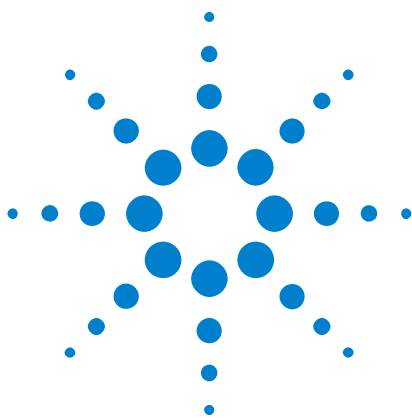

## 10 Debug Mode

Debug mode can be selected to make enable the ability to change jitter measurement options. In the **Configuration** tab, select the **Debug** radio button. This will add the following options:

- **Rj Bandwidth** – Choose the Rj Filter. Options are Narrow (Pink) or Wide (White). This changes the amount of DC jitter in the Rj measurement.
- **Jitter Pattern Length** – Choose Periodic or Arbitrary. Periodic is used for data patterns that are periodic and repeat through the scope memory. Arbitrary is used for random data patterns or long data patterns (for example, PRBS31) that do not repeat through the scope memory. If Arbitrary is selected, set the ISI filters.
- **ISI Filter Lead** – When using Arbitrary mode for the Jitter Pattern Length, set the Leading ISI filter coefficient. To help select the correct ISI filter, see "*Application Note 1574: Choosing the ISI Filter Size for EZJIT Plus Arbitrary Data Jitter Analysis*" (at [www.agilent.com](http://www.agilent.com), literature part number 5989-4974EN).
- **ISI Filter Lag** – When using Arbitrary mode for the Jitter Pattern Length, set the Lagging ISI filter coefficient. Again, to help select the correct ISI filter, see "*Application Note 1574: Choosing the ISI Filter Size for EZJIT Plus Arbitrary Data Jitter Analysis*".





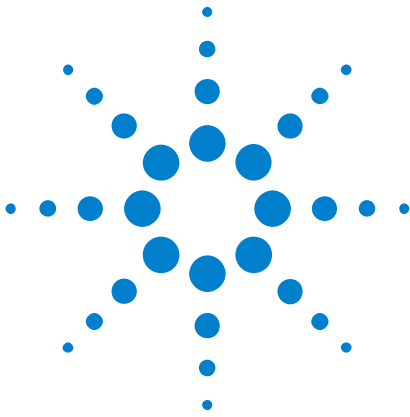

## A Calibrating the Infiniium Oscilloscope and Probe

Oscilloscope Internal Calibration 56

Probe Calibration 60

This section describes the Agilent Infiniium digital storage oscilloscope calibration procedures.



## Oscilloscope Internal Calibration

This will perform an internal diagnostic and calibration cycle for the oscilloscope. For the Agilent oscilloscope, this is referred to as Calibration.

### Required Equipment for Oscilloscope Calibration

To calibrate the Infiniium oscilloscope in preparation for running the automated tests, you need the following equipment:

- Keyboard, qty = 1, (provided with the Agilent Infiniium oscilloscope).
- Mouse, qty = 1, (provided with the Agilent Infiniium oscilloscope).
- Precision 3.5 mm BNC to SMA male adapter, Agilent p/n 54855-67604, qty = 2 (provided with the Agilent Infiniium oscilloscope).
- Calibration cable (provided with Agilent Infiniium oscilloscopes). Use a good quality 50  $\Omega$  BNC cable.
- BNC shorting cap.

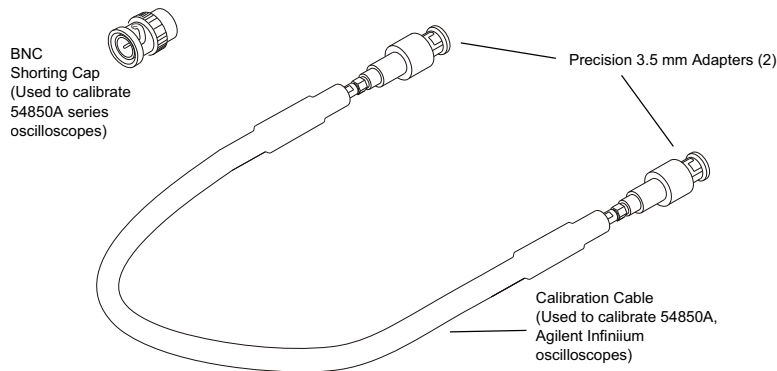

**Figure 15** Accessories Provided with the Agilent Infiniium Oscilloscope

### Running the Oscilloscope Internal Calibration

This Calibration will take about 20 minutes. Perform the following steps:

- 1 Set up the oscilloscope with the following steps:
  - a Connect the keyboard, mouse, and power cord to the rear of the oscilloscope.
  - b Plug in the power cord.
  - c Turn on the oscilloscope by pressing the power button located on the lower left of the front panel.
  - d Allow the oscilloscope to warm up at least 30 minutes prior to starting the calibration procedure in step 3 below.



- 2 Locate and prepare the accessories that will be required for the internal calibration:
  - a Locate the BNC shorting cap.
  - b Locate the calibration cable.
  - c Locate the two Agilent precision SMA/BNC adapters.
  - d Attach one SMA adapter to the other end of the calibration cable - hand tighten snugly.
  - e Attach another SMA adapter to the other end of the calibration cable - hand tighten snugly.
- 3 Referring to the following figure, perform the following steps:
  - a Click the **Utilities > Calibration...** menu to open the Calibration dialog box.

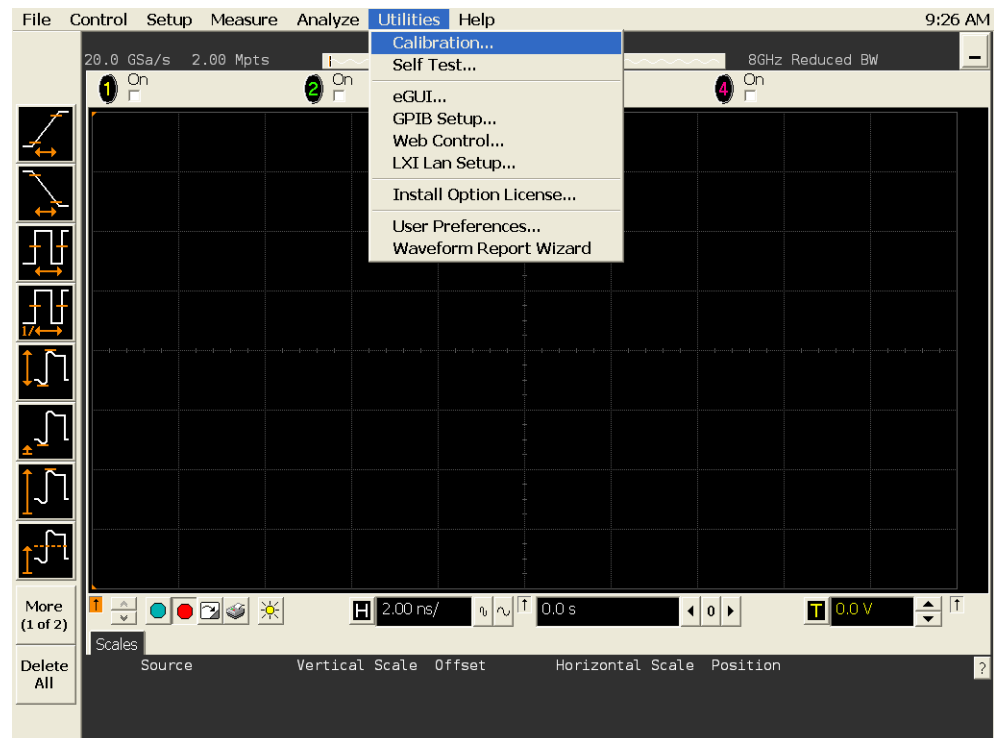

**Figure 16** Accessing the Calibration Menu

- 4 Referring to the following figure, perform the following steps to start the calibration:

## A Calibrating the Infiniium Oscilloscope and Probe

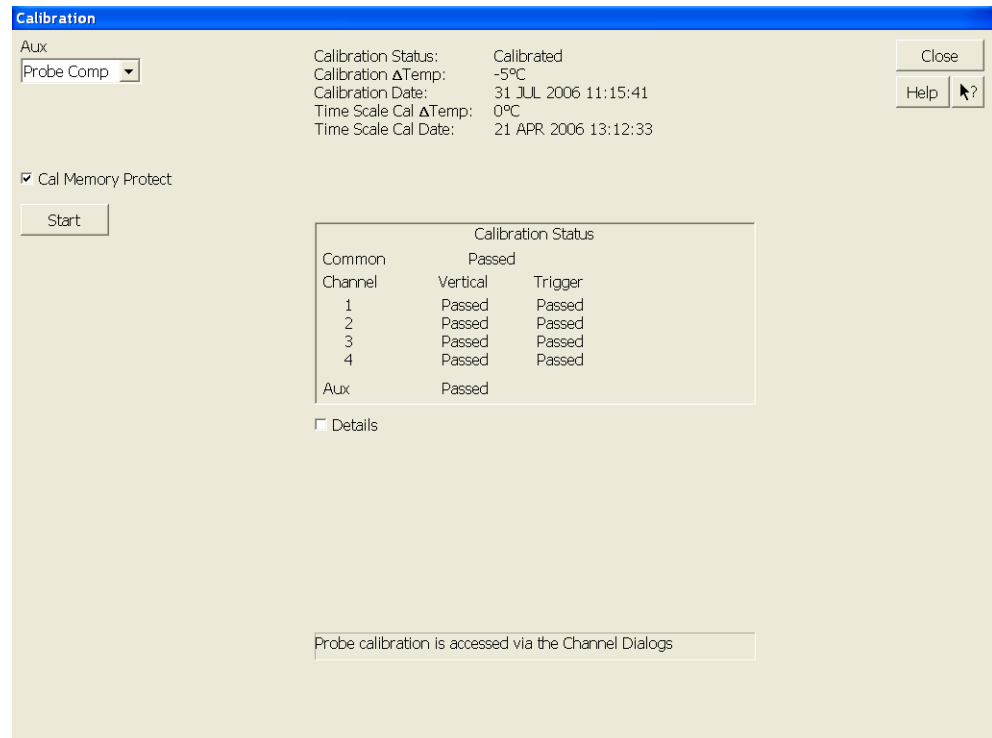

**Figure 17** Oscilloscope Calibration Window

- a Uncheck the **Cal Memory Protect** checkbox.
- b Click the **Start** button to begin the calibration.
- c During the calibration of channel 1, if you are prompted to perform a **Time Scale Calibration**, as shown in the following figure, click the **Std+Dflt** button to continue the calibration, using the Factory default calibration factors.

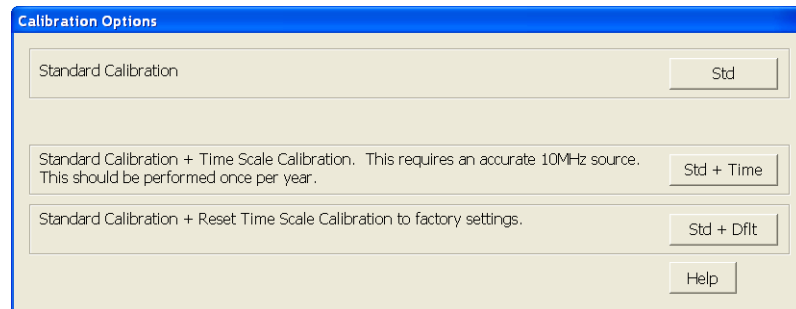

**Figure 18** Time Scale Calibration Dialog Box

- d** When the calibration procedure is complete, you will be prompted with a Calibration Complete message window. Click the **OK** button to close this window.
- e** Confirm that the Vertical and Trigger Calibration Status for all Channels passed.
- f** Click the **Close** button to close the calibration window.
- g** The internal calibration is completed.

**NOTE**

These steps do not need to be performed every time a test is run. However, if the ambient temperature changes more than 5 degrees Celsius from the calibration temperature, this calibration should be performed again. The delta between the calibration temperature and the present operating temperature is shown in the **Utilities > Calibration...** menu.

## Probe Calibration

Before performing the automated tests, you should calibrate the probes. Calibration of the solder-in probe heads consist of a vertical calibration and a skew calibration. The vertical calibration should be performed before the skew calibration. Both calibrations should be performed for best probe measurement performance.

### Required Equipment for Probe Calibration

The calibration procedure requires the following parts.

- BNC (male) to SMA (male) adapter.
- Deskew fixture.
- 50  $\Omega$  SMA terminator.

### Connecting the Probe for Calibration

For the following procedure, refer to the following figure.

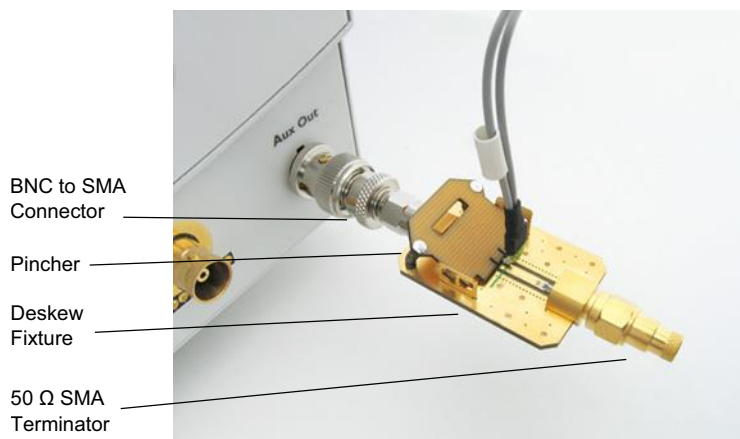

**Figure 19** Solder-in Probe Head Calibration Connection Example

- 1 Connect BNC (male) to SMA (male) adapter to the deskew fixture on the connector closest to the yellow pincher.
- 2 Connect the 50 Ω SMA terminator to the connector farthest from yellow pincher.
- 3 Connect the BNC side of the deskew fixture to the Aux Out BNC of the Infiniium oscilloscope.
- 4 Connect the probe to an oscilloscope channel.
- 5 To minimize the wear and tear on the probe head, it should be placed on a support to relieve the strain on the probe head cables.
- 6 Push down the back side of the yellow pincher. Insert the probe head resistor lead underneath the center of the yellow pincher and over the center conductor of the deskew fixture. The negative probe head

## A Calibrating the Infiniium Oscilloscope and Probe

resistor lead or ground lead must be underneath the yellow pincher and over one of the outside copper conductors (ground) of the deskew fixture. Make sure that the probe head is approximately perpendicular to the deskew fixture.

- 7 Release the yellow pincher.

### Verifying the Connection

- 1 On the Infiniium oscilloscope, press the **[Auto Scale]** key on the front panel.
- 2 Set the volts per division to **100 mV/div**.
- 3 Set the horizontal scale to **1.00 ns/div**.
- 4 Set the horizontal position to approximately **3 ns**. You should see a waveform similar to that in the following figure.

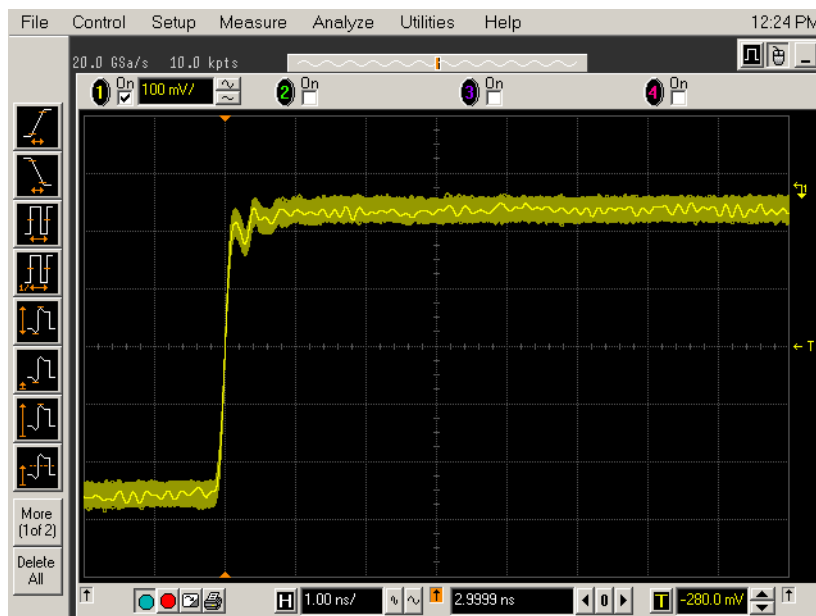

**Figure 20** Good Connection Waveform Example

If you see a waveform similar to that of the following figure, then you have a bad connection and should check all of your probe connections.

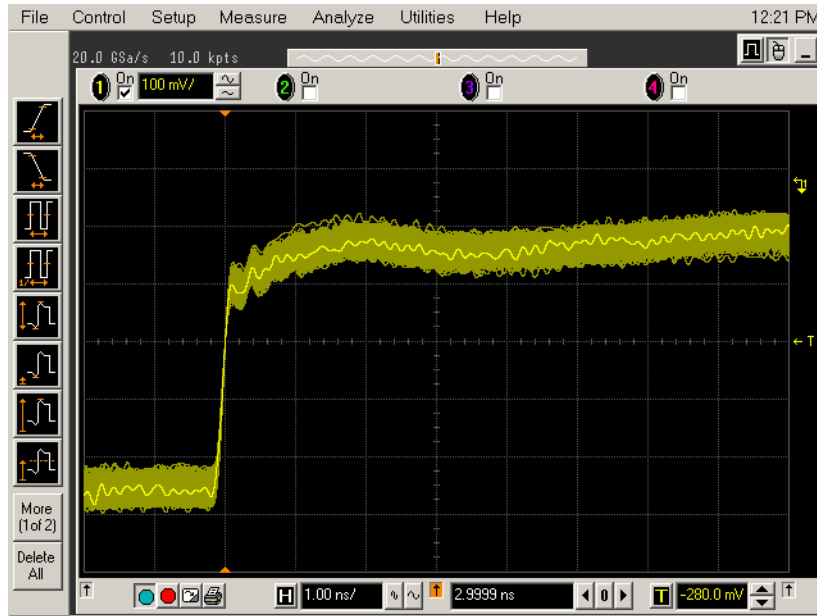

Figure 21 Bad Connection Waveform Example

## Running the Probe Calibration and Deskew

- 1 On the Infiniium oscilloscope in the **Setup** menu, select the channel connected to the probe, as shown in the following figure.

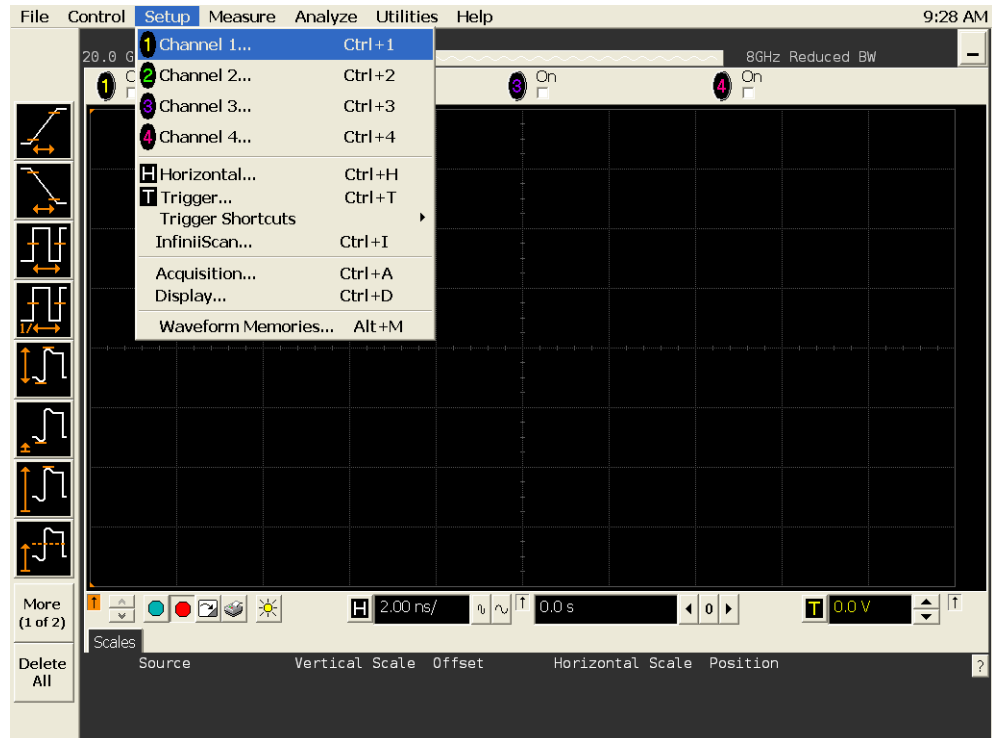
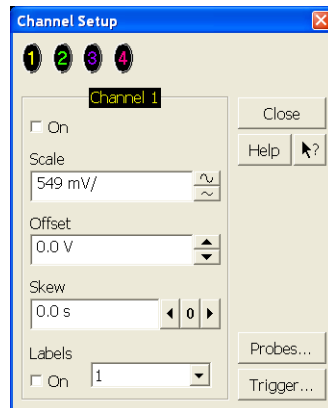

Figure 22 Channel Setup Window

- 2 In the Channel Setup dialog box, select the **Probes...** button, as shown in the following figure.





**Figure 23** Channel Dialog Box

- 3 In the Probe Setup dialog box, select the **Calibrate Probe...** button.

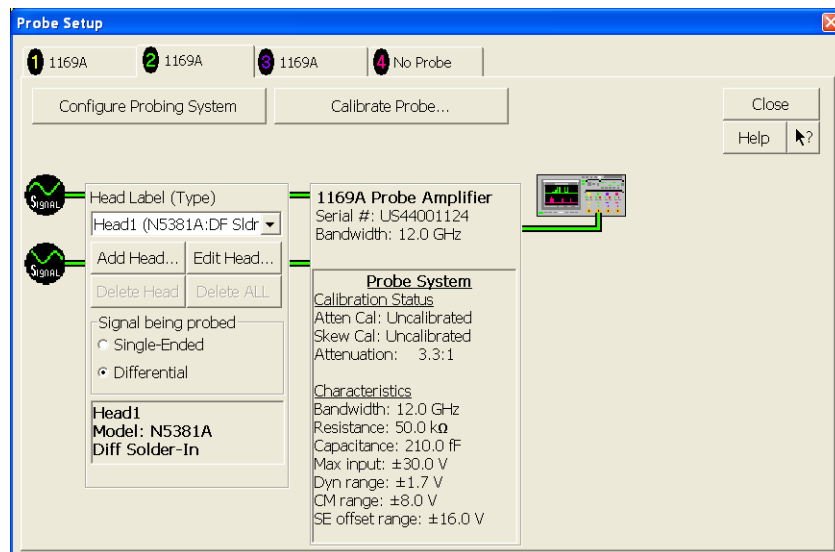

**Figure 24** Probe Setup Window

- 4 In the Probe Calibration dialog box, select the **Calibrated Atten/Offset** radio button.
- 5 Select the **Start Atten/Offset Calibration...** button and follow the on-screen instructions for the vertical calibration procedure.

## A Calibrating the Infiniium Oscilloscope and Probe

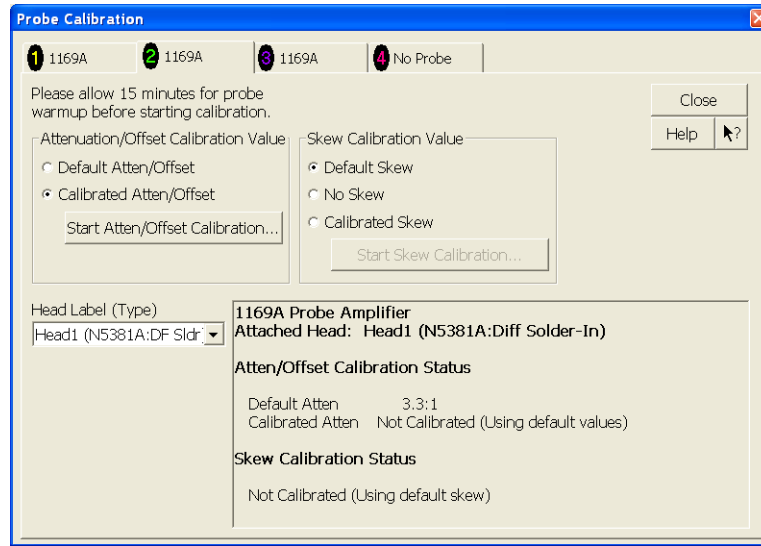

**Figure 25** Probe Calibration Window

- 6 Once the vertical calibration has successfully completed, select the **Calibrated Skew...** button.
- 7 Select the **Start Skew Calibration...** button and follow the on-screen instructions for the skew calibration.

At the end of each calibration, the oscilloscope will prompt you if the calibration was or was not successful.

### Verifying the Probe Calibration

If you have successfully calibrated the probe, it is not necessary to perform this verification. However, if you want to verify that the probe was properly calibrated, the following procedure will help you verify the calibration.

The calibration procedure requires the following parts:

- BNC (male) to SMA (male) adapter.
- SMA (male) to BNC (female) adapter.
- BNC (male) to BNC (male) 12 inch cable such as the Agilent 8120-1838.
- Agilent 54855-61620 calibration cable (Infiniium oscilloscopes with bandwidths of 6 GHz and greater only).
- Agilent 54855-67604 precision 3.5 mm adapters (Infiniium oscilloscopes with bandwidths of 6 GHz and greater only).
- Deskew fixture.

For the following procedure, refer to the following figure.

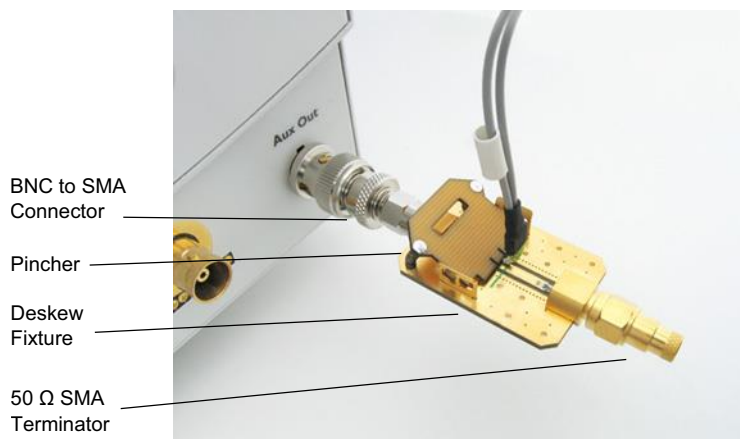

**Figure 26** Probe Calibration Verification Connection Example

- 1 Connect BNC (male) to SMA (male) adapter to the deskew fixture on the connector closest to the yellow pincher.
- 2 Connect the SMA (male) to BNC (female) to the connector farthest from the yellow pincher.
- 3 Connect the BNC (male) to BNC (male) cable to the BNC connector on the deskew fixture to one of the unused oscilloscope channels. For infiniium oscilloscopes with bandwidths of 6 GHz and greater, use the 54855-61620 calibration cable and the two 54855-64604 precision 3.5 mm adapters.
- 4 Connect the BNC side of the deskew fixture to the Aux Out BNC of the Infiniium oscilloscope.
- 5 Connect the probe to an oscilloscope channel.

- 6 To minimize the wear and tear on the probe head, it should be placed on a support to relieve the strain on the probe head cables.
- 7 Push down on the back side of the yellow pincher. Insert the probe head resistor lead underneath the center of the yellow pincher and over the center conductor of the deskew fixture. The negative probe head resistor lead or ground lead must be underneath the yellow pincher and over one of the outside copper conductors (ground) of the deskew fixture. Make sure that the probe head is approximately perpendicular to the deskew fixture.
- 8 Release the yellow pincher.
- 9 On the oscilloscope, press the autoscale button on the front panel.
- 10 Select Setup menu and choose the channel connected to the BNC cable from the pull-down menu.
- 11 Select the **Probes...** button.
- 12 Select the **Configure Probe System** button.
- 13 Select **User Defined Probe** from the pull-down menu.
- 14 Select the **Calibrate Probe...** button.
- 15 Select the **Calibrated Skew** radio button.
- 16 Once the skew calibration is completed, close all dialog boxes.
- 17 Select the **Start Skew Calibration...** button and follow the on-screen instructions.
- 18 Set the vertical scale for the displayed channels to **100 mV/div**.
- 19 Set the horizontal range to **1.00 ns/div**.
- 20 Set the horizontal position to approximately **3 ns**.
- 21 Change the vertical position knobs of both channels until the waveforms overlap each other.
- 22 Select the Setup menu choose **Acquisition...** from the pull-down menu.
- 23 In the Acquisition Setup dialog box enable averaging. When you close the dialog box, you should see waveforms similar to that in the following figure.

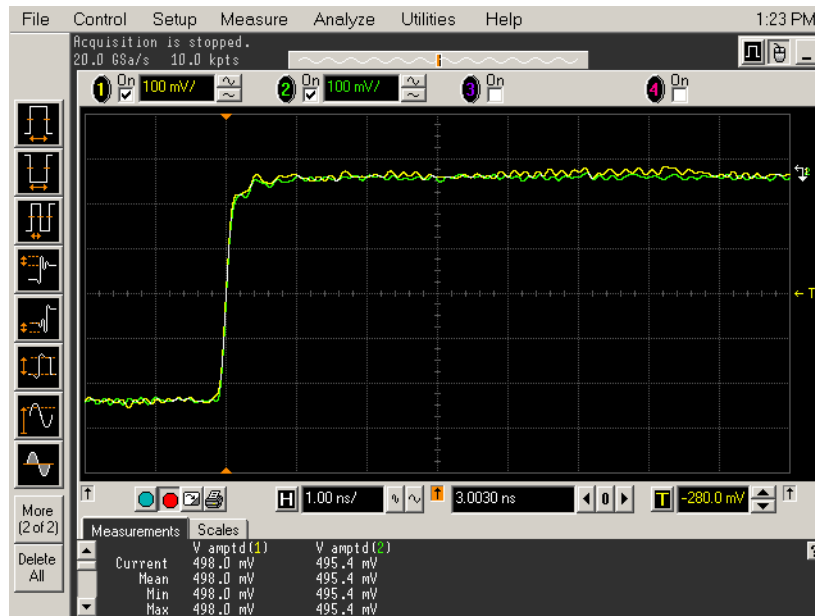

**Figure 27** Calibration Probe Waveform Example

#### NOTE

Each probe is calibrated with the oscilloscope channel to which it is connected. Do not switch probes between channels or other oscilloscopes, or it will be necessary to calibrate them again. It is recommended that the probes be labeled with the channel on which they were calibrated.

## **A Calibrating the Infiniium Oscilloscope and Probe**

# Index

## Numerics

100GBASE-KR4 compliance test application, 3

## A

AC Common Mode Output Voltage Test, 19  
application software, installing, 8  
application software, starting, 13  
Automation tab, 14

## B

BNC shorting cap, 56  
BNC to SMA male adapter, 56  
bounded uncorrelated jitter, 24

## C

calibrating the oscilloscope, 12, 55  
calibration cable, 56  
Configure tab, 14  
Connect tab, 14

## D

data rate, 23  
data rate and jitter measurements, 21  
DC Common Mode Output Voltage Test, 18  
Debug Mode, 53  
deskew and probe calibration, running, 64  
Differential Peak-to-Peak Output Voltage Test, 20  
Differential Peak-to-Peak Output Voltage Test with TX Disabled, 17  
DME Differential Peak-to-Peak Output Voltage Test, 46  
DME T1-Transition Position Spacing (Period) Test, 47  
DME T2-Clock Transition to Clock Transition Test, 48  
DME T3-Clock Transition to Data Transition Test, 49  
DME/EEE waveform measurements, 43  
DME/EEE waveform specifications, 44

## E

EEE Common Mode Deviation Voltage Test, 52  
EEE Differential Peak-to-Peak Output Voltage Test, 51

EEE Differential Peak-to-Peak Output Voltage Test with TX Disabled, 50  
equipment required for calibration, 56  
equipment required for probe calibration, 60  
even-odd jitter, 24

## F

full scale range measurements, 37

## H

HTML Report tab, 14

## I

installation, 7  
ISI Filter Lag, 53  
ISI Filter Lead, 53

## J

jitter, 24  
jitter and data rate measurements, 21  
Jitter Pattern Length, 53

## K

keyboard, 56

## L

license key, installing, 9  
Linear Fit Pulse Peak, 28

## M

main voltage measurements, 15  
main voltage specifications, 16  
measurements, preparing, 11  
Minimum Post-cursor Full-scale Test, 40  
Minimum Pre-cursor Full-scale Test, 39  
mouse, 56

## N

Normalized Coefficient Step Size c(1) dec c(0) hold c(-1) hold, 32  
Normalized Coefficient Step Size c(1) hold c(0) dec c(-1) hold, 34

Normalized Coefficient Step Size c(1) hold c(0) hold c(-1) dec, 36  
Normalized Coefficient Step Size c(1) hold c(0) hold c(-1) inc, 35  
Normalized Coefficient Step Size c(1) hold c(0) inc c(-1) hold, 33  
Normalized Coefficient Step Size c(1) inc c(0) hold c(-1) hold, 31  
normalized coefficient step size measurements, 29  
notices, 3

## O

oscilloscope calibration, 12  
oscilloscope internal calibration, 56  
oscilloscope internal calibration, running, 56

## P

precision 3.5 mm BNC to SMA male adapter, 56  
probe calibration, 60  
probe calibration and deskew, running, 64  
probe calibration connection, verifying, 62  
probe calibration, connecting, 60  
probe calibration, verifying, 66

## R

random jitter, 24  
Results tab, 14  
return loss ENA/PNA measurements, 41  
Rj Bandwidth, 53  
Run Tests tab, 14

## S

Select Tests tab, 14  
Set Up tab, 14  
specifications, DME/EEE waveform, 44  
specifications, main voltage, 16  
specifications, transmitter output, 22, 26  
Steady State Voltage Vf, 27

## T

transmitter output specifications, 22, 26  
transmitter output waveform measurements, 25

