

Agilent N9322C Spectrum Analyzer

User's Guide

Notices

© Agilent Technologies, Inc. 2012

No part of this manual may be reproduced in any form or by any means (including electronic storage and retrieval or translation into a foreign language) without prior agreement and written consent from Agilent Technologies, Inc. as governed by United States and international copyright laws.

Manual Part Number

N9322-90002

Edition

First Edition, November 2012

Printed in China

Agilent Technologies, Inc.
No. 116 Tian Fu 4st Street
Hi-Tech Industrial Zone (South)
Chengdu 610041, China

Software Revision

This guide is valid for firmware revision A.04.20 or later of the N9322C Spectrum Analyzer.

Warranty

The material contained in this document is provided “as is,” and is subject to being changed, without notice, in future editions. Further, to the maximum extent permitted by applicable law, Agilent disclaims all warranties, either express or implied, with regard to this manual and any information contained herein, including but not limited to the implied warranties of merchantability and fitness for a particular purpose. Agilent shall not be liable for errors or for incidental or consequential damages in connection with the furnishing, use, or performance of this document or of any information contained herein. Should Agilent and the user have a separate written agreement with warranty terms covering the material in this document that conflict with these terms, the warranty terms in the separate agreement shall control.

Technology Licenses

The hardware and/or software described in this document are furnished under a license and may be used or copied only in accordance with the terms of such license.

Restricted Rights Legend

U.S. Government Restricted Rights. Software and technical data rights granted to the federal government include only those rights customarily provided to end user customers. Agilent provides this customary commercial license in Software and technical data pursuant to FAR 12.211 (Technical Data) and 12.212 (Computer Software) and, for the Department of Defense, DFARS 252.227-7015 (Technical Data - Commercial Items) and DFARS 227.7202-3 (Rights in Commercial Computer Software or Computer Software Documentation).

Safety Notices

CAUTION

A **CAUTION** notice denotes a hazard. It calls attention to an operating procedure, practice, or the like that, if not correctly performed or adhered to, could result in damage to the product or loss of important data. Do not proceed beyond a **CAUTION** notice until the indicated conditions are fully understood and met.

WARNING

A **WARNING** notice denotes a hazard. It calls attention to an operating procedure, practice, or the like that, if not correctly performed or adhered to, could result in personal injury or death. Do not proceed beyond a **WARNING** notice until the indicated conditions are fully understood and met.

In This User's Guide...

This guide contains operation information for the N9322C Spectrum Analyzer. The following are descriptions of the chapters within this book.

1 Overview

A description of the front and rear panels.

2 Getting Started

Unpacking and setting up the analyzer.

3 Functions and Measurements

How to use the basic applications of the analyzer.

4 Key Reference

Front-panel hardkey descriptions and the related softkeys menu functions.

5 Instrument Messages

Descriptions of the instrument messages of the analyzer.

6 Troubleshooting

Information and tips on what to do when instrument difficulties are encountered.

7 Menu Maps

Menu maps, the structure of the menus and what the user will see when making instrument parameter selections.

For more information about N9322C Spectrum Analyzer, see www.agilent.com/find/n9322c.

Contents

1	Overview	1
	Agilent N9322C at a Glance	2
	Front Panel Overview	4
	Display Annotations	7
	Rear Panel Overview	9
	Front and rear panel symbols	10
2	Getting Started	11
	Check the Shipment and Order List	12
	Options	12
	Safety Notice	13
	Power Requirements	14
	Power On and Check	16
	Environmental Requirements	18
	Electrostatic Discharge Protection	21
	BSA PC software	22
	Helpful Tips	23
	Perform Calibration	23
	Using an External Reference	24
	Enable an Options	24
	Firmware Upgrade	25
	IO Configuration	25
	Timed Power On/Off	26
	Power Preset Last	26
	Data Securities	27
	Probe Power Output	27
3	Functions and Measurements	29
	Making a Basic Measurement	30

Contents

Using the Front Panel	30
Presetting the Spectrum Analyzer	31
Viewing a Signal	33
Measuring Multiple Signals	35
Comparing Signals on the Same Screen Using Marker Delta	35
Comparing Signals not on the Same Screen Using Marker Delta	37
Resolving Signals of Equal Amplitude	39
Resolving Small Signals Hidden by Large Signals	42
Measuring a Low-Level Signal	44
Reducing Input Attenuation	44
Decreasing the Resolution Bandwidth	46
Trace Averaging	47
Improving Frequency Resolution and Accuracy	49
Tracking Drifting Signals	51
Making Distortion Measurements	53
Identifying Analyzer Generated Distortion	53
Third-Order Intermodulation Distortion	56
Stimulus Response Transmission	59
Measuring Stop Band Attenuation of a Lowpass Filter	61
Channel Scanner	64
Top/Bottom N Channel Scanner	64
List N Channel Scanner	66
Channel Scanner Setup	68
Spectrum Monitor	69
Reflection Measurement	71
Preparation	71
Measuring Cable Reflection	72
Measuring Distance to Fault	72
Making a Power Measurement with USB Power Sensor	74

Making an Average Power Measurement	75
Making a Peak Power Measurement	79
Power Meter Settings	81
Demodulate the AM/FM signal	84
Demodulating an AM Signal	84
Demodulating an FM Signal	85
Analysis the Modulated Signals	87
AM/FM Modulation Analysis	87
ASK/FSK Modulation Analysis	90
Measuring Channel Power	93
Files Operation	95
4Key Reference	101
Amplitude	102
BW	106
Display	109
Enter	110
ESC <-	110
Frequency	111
Marker	114
Meas	119
Channel Power	119
Occupied BW	121
ACPR	123
Spectrum Emission Mask	124
MODE	130
Tracking Generator	130
Power Meter	133
Spectrum Monitor	136

Contents

Reflection Measurement	138
AM/FM Modulation Analysis	140
ASK/FSK Modulation Analysis	144
Peak Search	148
System	151
Span	154
Sweep	155
Limit	159
Trace	162
5Instrument Messages	167
Overview	168
Command Errors	169
Execution Conflict	171
Device-Specific Errors	173
6Troubleshooting	177
Check the basics	178
Contact Agilent Technologies	180
7Menu Maps	181
Amplitude Menu	182
BW/Avg Menu	183
Det/Display Menu	184
File Menu (1 of 2)	185
File Menu (2 of 2)	186
Frequency Menu	187

Marker Menu	188
Marker-> Menu	189
Measure Menu (1 of 2)	190
Measure Menu (2 of 2)	191
MODE - Tracking Generator	192
MODE - Power Meter	193
MODE - AM/FM Modulation Analysis	194
MODE - ASK/FSK Modulation Analysis	195
Name Editor Menu	196
Peak Search Menu	197
Preset/System Menu	198
SPAN Menu	199
Sweep/Trig Menu	200
Trace Menu	201
Index	203

Contents

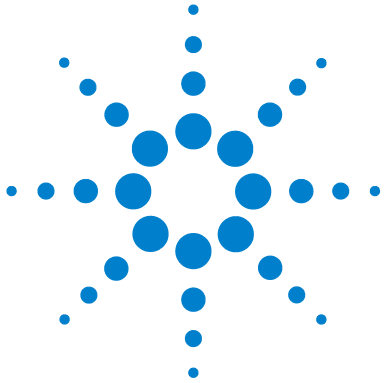

1 Overview

Agilent N9322C at a Glance	2
Front Panel Overview	4
Rear Panel Overview	9
Front and rear panel symbols	10

This chapter provides a description of the Agilent N9322C spectrum analyzer and an introduction to the buttons, features, and functions of the front and rear instrument panels.

For the latest product information, please refer to the link below:

<http://www.agilent.com/find/n9322c>

For the latest option information, please refer to the link below:

http://www.agilent.com/find/sa_upgrades

Agilent N9322C at a Glance

The Agilent N9322C spectrum analyzer is a portable, swept spectrum analyzer with a frequency range of 9 kHz to 7.0 GHz. It can be widely used in an electronic manufacturing environment and in functional/final/QA test systems.

Features

The Agilent N9322C spectrum analyzer primary features and functions are described below:

- **Power Measurement Suite**

The built-in one-button power measurement suite offers channel power, ACP, OBW, and TOI measurements, and contains a Pass/Fail testing capability with a mask for out-of-channel emissions measurement.

- **Precision Frequency Reference (Option PFR)**

The optimal OCXO frequency reference provides the precise frequency measurement capability.

- **Spectrum Monitor (Option MNT)**

Provides the capability to analyze the stability of a signal over time. The analyzer can be used to monitor the signal capturing performance or intermittent event over extended periods of time.

- **High Sensitive Measurement (Option P07)**

Includes an optional pre-amplifier for signals in the frequency range up to 7 GHz, enabling more sensitive measurements. This feature is a great help in analysis of low level signals.

- **High Accuracy Power Measurement**

Supports Agilent U2000 series (option PWM) and U2020 series (option PWP) power sensors for high accuracy power measurement as a power meter.

- **Modulation Analysis Function**

provides optional AM/FM and ASK/FSK modulation analysis function. (AM/FM: Option-AMA ASK/FSK: Option-DMA)

- **Tracking Generator (Option TG7)**

provides an RF source for scalar network analysis.

- **Baseband Channel (Option BB1)**

Provides superior DANL and SSB between 9 kHz to 10 MHz.

- **Cable & Antenna Test (Option RM7; Requires option TG7)**

Provides VSWR, return loss, cable loss and distance-to-fault function for reflection measurement.

- **Task Planner (Option TPN)**

Provides task planner function to integrate different measurements for test automation.

- **Time-gated Spectrum Analysis (Option TMG)**

Measures any one of several signals separated in time and exclude interfering signals.

- **Channel Scanner (Option SCN)**

provide the channel scan function in spectrum monitoring, coverage test, and band clearance.

Optimized Usability

The analyzer provides the enhanced usability as below:

- **Socket/Telnet** remote control via USB, and LAN port.
- The **BSA PC Software** on help kit CD provides further editing and data analysis functions.
- Keypad can be **locked** and unlocked with password to forbid undesired keypad operation.
- The **GPIB interface** (option G01) make the unit easily compatible with your GPIB test system.
- **Security features (Option SEC)** allows user to erase all customized files and data in analyzer for security.

Front Panel Overview

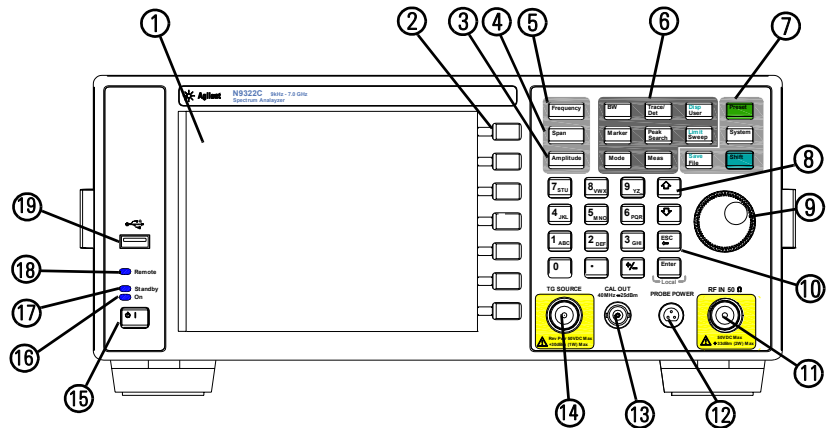

- 1 **Screen** 6.5 inch TFT color screen shows information of the current function, including the signal traces, status indicators, and instrument messages. Labels for softkeys are located on the right-hand side of the screen.
- 2 **Softkeys** are the unlabeled keys next to the screen. They activate functions displayed to the left of each key.
- 3 **Amplitude** activates the reference level function and accesses the amplitude softkeys, with which you set functions that affect data on the vertical axis.
- 4 **SPAN** sets the frequency range symmetrically about the center frequency. The frequency-span readout describes the total displayed frequency range.
- 5 **Frequency** activates the center-frequency function, and accesses the menu of frequency functions.
- 6 **Function Keys** relate directly to the following main functions:
 - **BW** activates the resolution bandwidth function and accesses the softkeys that control the bandwidth functions and averaging.
 - **Trace/Det** accesses the softkeys that allow you to set up the trace settings and detector functions.

- **Disp - User** accesses the submenu to recall the frequently used user-defined state, or control what is displayed on the analyzer, including the display line, graticule and annotation after pressing **Shift**.
- **Mode** selects the measurement mode according to the activated options.
- **Marker** accesses the marker control keys that select the type and number of markers and turns them on and off.
- **Limit - Sweep** accesses the softkeys that allow you to set the sweep time, select the sweep mode and trigger mode, or to set the limit functions after pressing **Shift**.
- **Peak Search** places a marker on the signal peak.
- **Meas** accesses the measurements mode selection submenu in spectrum analyzer mode or the measurement submenu in other optional modes.

7 Utility Keys relate directly to the following utilities:

- **Preset** resets the analyzer to a known state
- **System** accesses the submenu to configure a series of system settings, such as ports, option and languages.
- **Shift** switches alternate upper blue function of the hardkeys.
- **Save - File** accesses the file operation submenu or activate the quick-save function after pressing **Shift**.

8 Arrow Keys The up and down arrow keys shift the selected item when you press **[MODE]** hardkey; you can also change the mode by rotating the knob.

9 Knob The knob increases or decreases a value, a numeric digit, or scrolls up and down to select an item in a list.

10 Data Control Keys includes the numeric keypad, **ENTER** key and backspace key, change the numeric value of an active function such as center frequency, start frequency, resolution bandwidth, and marker position. if the analyzer is in the remote mode, pressing **ENTER** key returns the analyzer to the local mode and enables front-panel control.

- 11 **RF IN connector** receives the signal input. The maximum damage level is average continuous power +33 dBm or DC voltage 50 VDC. The impedance is 50 Ω . (N-type female).
- 12 **PROBE POWER connector** provides power for high-impedance AC probes or other accessories (+15 V, -12 V, 150 mA maximum).
- 13 **CAL OUT connector** provides an amplitude reference signal output of 40 MHz at -25 dBm (BNC female).
- 14 **TG SOURCE connector** N-type female, is the source output for the built-in tracking generator. The maximum damage level is average continuous power +30 dBm or DC voltage 50 VDC. The impedance is 50 Ω . (for Option TG7)
- 15 **Standby Switch** switches on all functions of the analyzer. To switch the analyzer off, press the switch for at least 2 seconds. This deactivates all the functions but retains power to internal circuits so long as the analyzer is connected to line power.
- 16 **On LED** (green) lights when the analyzer is switched on.
- 17 **Standby LED** lights when the analyzer is connected to the line power.
- 18 **Remote LED** lights when the analyzer is remotely controlled by a PC via the USB host interface on the rear panel.
- 19 **USB Device Connector** provides a connection between external USB devices and the analyzer, such as a USB memory device.

Display Annotations

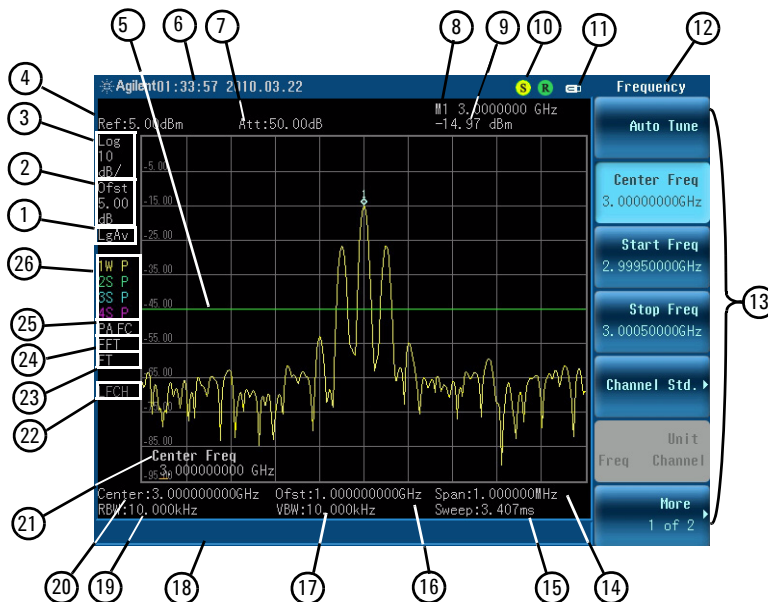

Item	Description	Notes (Associated function key)
1	Average Type	[BW] > Average Type
2	Reference Offset	[Amplitude] > Ref Offset
3	Amplitude scale	[Amplitude] > Scale Type
4	Reference level	[Amplitude] > Ref Level
5	Display Line	[Disp] > Display Line
6	Time and date display	[System] > Time/Date
7	RF attenuation	[Amplitude] > Attenuation
8	Marker frequency	[Marker]
9	Marker amplitude	[Marker]
10	Indicator	S - Shift R - Remote Control
11	USB disk indicator	The USB memory device is in use.
12	Key menu title	Dependent on key selection.

1 Overview

13	Softkey menu	Refer to “ Key Reference ” for details. Dependent on current function key selection.
14	Frequency span	[SPAN]
15	Sweep time	[Sweep] > Sweep Time
16	Frequency offset	[Frequency] > Freq Offset
17	Video bandwidth	[BW] > Video BW
18	Display status line	Display status and instrument messages.
19	Resolution bandwidth	[BW] > Res BW
20	Center Frequency	[Frequency] > Center Freq
21	Active function block	The function in use
22	Low frequency channel	[Frequency] > LowFrqChannel
23	Sweep time rule	[Sweep] > Sweep Setup > Swp Time Rule
24	Sweep type	[Sweep] > Sweep Setup > Sweep Type
25 - right	Trigger/Sweep F - free run trigger V - video trigger E - external trigger C - continuous sweep S - single sweep	[Sweep] > Triggs
25 - left	Internal preamp	[Amplitude] > Int Preamp
26	Trace mode W - clear write M - maximum hold m - minimum hold V - view S - store blank	[Trace]
	Detect mode N - Normal A - Average P - Positive peak S - Sample N - Neg Peak	[Trace] > Detector

Rear Panel Overview

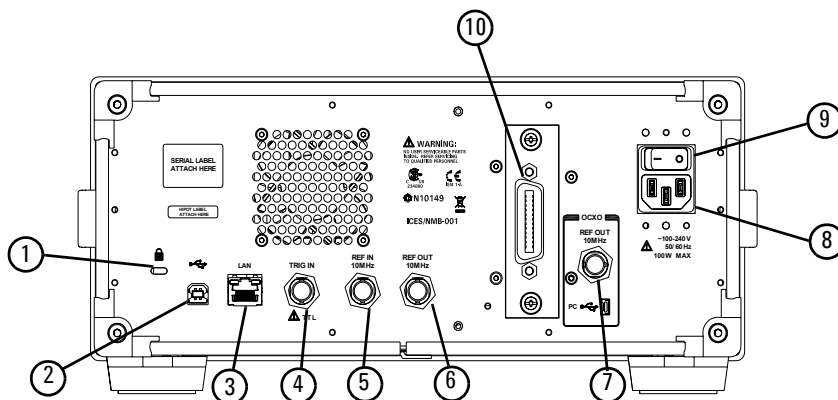

- 1 **Kensington Lock** lock the instrument and keep its safety.
- 2 **USB Host connector** provides a connection between the analyzer and an PC for remote control.
- 3 **LAN port** A TCP/IP Interface used for remote operation.
- 4 **EXT TRG IN (TTL) connector** accepts an external voltage input, the positive edge of which triggers the analyzer sweep function. (BNC female)
- 5 **REF IN connector** accepts an external timebase with a frequency of 10 MHz, amplitude of -5 to $+10$ dBm. (BNC female)
- 6 **REF OUT connector** provides a frequency of 10 MHz, amplitude of -10 dBm reference output. (BNC female)
- 7 **REF OUT connector (Option PFR)** is an optional connector for precision 10 MHz reference from OCXO.
- 8 **AC Power Receptacle** accepts a three-pin line power plug.
- 9 **Power switch** isolates the analyzer from the AC line power. After switch on, the analyzer enters into standby mode and the orange standby LED on the front panel lights.
- 10 **GPIB connector (Option G01)** is an optional interface. This GPIB connector supports remote operation.

Front and rear panel symbols



The instruction manual symbol: indicates that the user must refer to specific instructions in the manual.



The CE mark: a registered trademark of the European Community.



The CSA mark: a registered trademark of the Canadian Standards Association International.

ICES/NMB-001

The ISM device complies with Canadian Interference-Causing Equipment Standard-001.
Cet appareil ISM est conforme à la norme NMB-001 du Canada.



The C-Tick mark: a trademark registered to the Australian Communication Media Authority. It indicates compliance with all Australian EMC regulatory information.



marks the “on/standby” position of the switch.



indicates that the instrument requires AC power input.



indicates this product complies with the **WEEE Directive**(2002/96/EC) marking requirements and you must not discard this equipment in domestic household waste. Do not dispose in domestic household waste. To return unwanted products, contact your local Agilent office, or refer to <http://www.agilent.com/environment/product/>



2 Getting Started

Check the Shipment and Order List	12
Safety Notice	14
Power Requirements	15
Power On and Check	17
Environmental Requirements	19
Electrostatic Discharge Protection	22
Helpful Tips	23

This chapter helps you in preparing the spectrum analyzer for use and provides the information to start using the spectrum analyzer correctly.

Check the Shipment and Order List

After receiving the shipment, first check the shipment and your order list. Inspect the shipping container and the cushioning material for signs of stress. Retain the shipping materials for future use, as you may wish to ship the analyzer to another location or to Agilent Technologies for service. Verify that the contents of the shipping container are complete.

Shipping Problems?

If the shipping materials are damaged or the contents of the container are incomplete, please contact the nearest Agilent Technologies office to arrange for repair or replacement. You will not need to wait for a claim settlement. If you must return an analyzer to Agilent Technologies, use the original (or comparable) shipping materials.

Options

Verify if that the shipment includes your ordered options by checking the option label on the shipping container.

Unless specified otherwise, all options are available when you order a spectrum analyzer; some options are also available as kits that you can order and install/activate after you receive the analyzer. Order kits through your local Agilent Sales and Service Office.

At the time of analyzer purchase, options can be ordered using your product number and the number of the option you are ordering. For example, if you are ordering option TG7, you would order N9322C-TG7.

If you are ordering an option after the purchase of your analyzer, you will need to add a K to the product number and then specify which option you are ordering. For example, N9322CK-TG7.

For the latest information on Agilent N9322C spectrum analyzer options and upgrade kits, visit the following Internet URL: <http://www.agilent.com/find/n9322c>

Safety Notice

Read the following warnings and cautions carefully before powering on the spectrum analyzer to ensure personal and instrument safety.

WARNING

Always use a well-grounded, three-pin AC power cord to connect to power source. Personal injury may occur if there is any interruption of the AC power cord. Intentional interruption is prohibited. If this product is to be energized via an external auto transformer for voltage reduction, make sure that its common terminal is connected to a neutral (earthed pole) of the power supply.

WARNING

Personal injury may result if the spectrum analyzer covers are removed. There are no operator-serviceable parts inside. To avoid electrical shock, refer servicing to qualified personnel.

WARNING

Electrical shock may result if the spectrum analyzer is connected to the power supply while cleaning. Do not attempt to clean internally.

CAUTION

Prevent damage to the instrument and ensure protection of the input mixer by limiting average continuous power input to +33 dBm, DC voltage to 50 VDC with ≥ 10 dB input attenuation. Instrument damage may result if these precautions are not followed.

CAUTION

To install the spectrum analyzer in other racks, note that they may promote shock hazards, overheating, dusting contamination, and inferior system performance. Consult your Agilent customer engineer about installation, warranty, and support details.

Power Requirements

The spectrum analyzer has an auto-ranging line voltage input. The AC power supply must meet the following requirements:

Voltage:	100 to 240 VAC
Frequency:	50 to 60 Hz
Power:	Maximum 100 W





AC Power Cord

The analyzer is equipped with a three-wire power cord, in accordance with international safety standards. This cable grounds the analyzer cabinet when connected to an appropriate power line outlet. The cable appropriate to the original shipping location is included with the analyzer.

Various AC power cables are available that are unique to specific geographic areas. You can order additional AC power cables for use in different areas. The table **AC Power Cords** lists the available AC power cables, the plug configurations, and identifies the geographic area in which each cable is appropriate.

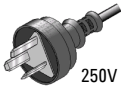
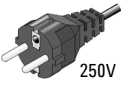
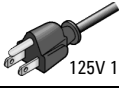
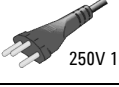
The detachable power cord is the product disconnecting device. It disconnects the mains circuits from the mains supply before other parts of the product. The front panel switch is only a standby switch and do not disconnect instrument from LINE power.

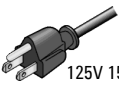
AC Power Cords

Plug Type	Cable Part Number	Plug ^a Description	For use in Country & Region
 250V 10A	8121-1703	BS 1363/A	Option 900 United Kingdom, Hong Kong, Singapore, Malaysia
 250V 10A	8120-0696	AS 3112:2000	Option 901 Australia, New Zealand
 250V 16A	8120-1692	IEC 83 C4	Option 902 Continental Europe, Korea, Indonesia, Italy, Russia
 125V 10A	8120-1521	CNS 10917-2 /NEMA 5-15P	Option 903 United States, Canada, Taiwan, Mexico
 250V 10A	8120-2296	SEV 1011	Option 906 Switzerland
 230V 15A	8120-4600	SABS 164-1	Option 917 South Africa, India
 125V 15A	8120-4754	JIS C8303	Option 918 Japan
 250V 16A	8120-5181	SI 32	Option 919 Israel
 250V 10A	8120-8377	GB 1002	Option 922 China



a. Plug description describes the plug only. The part number is for the complete cable assembly.

Power On and Check

- 1 Connect the AC power cord into the instrument. Insert the plug into a power socket provided with a protective ground. Set the tilt adjusters for your preference.

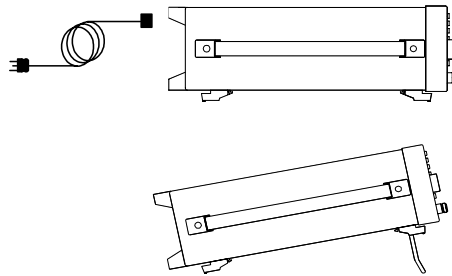
Figure 2-1 Plug in and angle adjustment



- 2 Press the AC line switch  on the rear panel. The standby LED on the front panel will light and the spectrum analyzer is in standby mode (AC power applied).
- 3 Press the standby switch  on the front panel. The On LED will light, and the spectrum analyzer boots up.

Self-initialization takes about 25 seconds; the spectrum analyzer then defaults to the menu mode. After power on, let the spectrum analyzer warm up for 45 minutes for stabilization.

NOTE

The front panel switch is a standby switch only; it is not a power switch. To completely disconnect the spectrum analyzer from the AC line power, shut off the power switch on the rear panel.

Check for Instrument Messages

The spectrum analyzer has two categories of instrument messages: error and warning messages. A error message is triggered by operation errors, for example, parameter setting conflicts or data input that is out of the range of a parameter. An warning message may be triggered by hardware defects which could result in damage to instrument.

Here are some tips to check the instrument messages.

- 1 Check the display to see if any messages display in the status bar. Press **[System] > System Info > Error History** to review each message. Refer to [Chapter 5](#), “Instrument Messages” for detailed system message descriptions.
- 2 When you have reviewed and resolved all of the error messages, press **[System] > System Info > Error History > Clear error queue** to delete the messages.
- 3 Cycle the power to the analyzer and re-check to see if the instrument messages are still there.
- 4 If the error messages cannot be resolved, please contact the Agilent Customer Contact Center for assistance or service.

Environmental Requirements

Agilent Technologies has designed this product for use in Installation Category II, Pollution Degree 2, per IEC 61010-1. Agilent has designed the spectrum analyzer for use under the following conditions:

- Indoor use
- Altitude < 3,000 meters
- Operating temperature range: +5 to +45 °C;
Storage temperature range: -20 to +70 °C
- Relative humidity range 15% to 95 %

NOTE

This equipment is Class A suitable for professional use and is for use in electromagnetic environments outside of the home.

Ventilation

Ventilation holes are located on the rear panel and one side of the spectrum analyzer cover. Do not allow these holes to be obstructed, as they allow air flow through the spectrum analyzer.

When installing the spectrum analyzer in a cabinet, do not restrict the convection of the analyzer. The ambient temperature outside the cabinet must be less than the maximum operating temperature of the spectrum analyzer by 4 °C for every 100 watts dissipated within the cabinet.

Cleaning Tips

To prevent electrical shock, disconnect the spectrum analyzer from line power before cleaning. Use a dry cloth or one slightly dampened with water to clean the external case parts. Do not attempt to clean internally.

Rack Mount

It is recommended to use the Agilent rackmount kit (option 1CM) to install the spectrum analyzer into a rack.

Do not attempt to rack mount the spectrum analyzer by the front panel handles only. This rackmount kit will allow mounting of the spectrum analyzer with or without handles.

Refer to the following instructions when installing the rackmount kit on the spectrum analyzer.

- 1 Remove feet, key-locks and tilt stands.
- 2 Remove side trim strips and one middle screw per side.

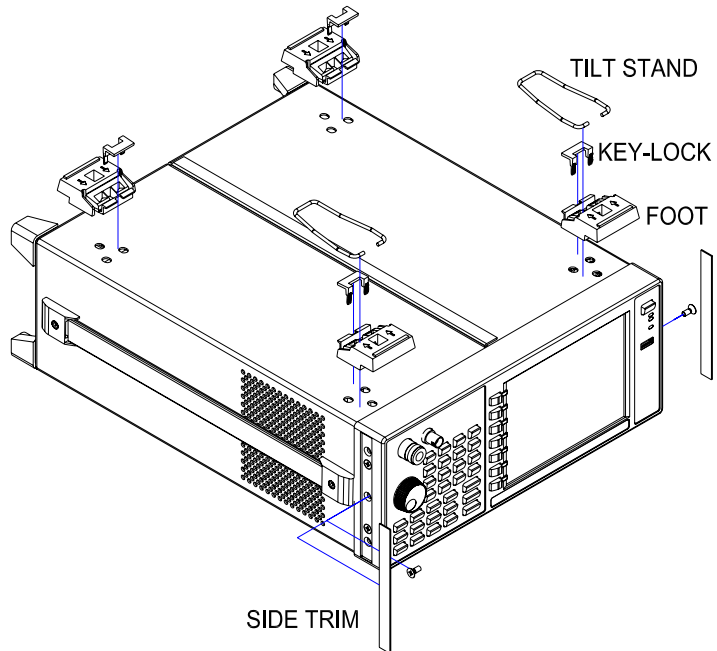

- 3 Attach rackmount flange and front handle assembly with 3 screws per side.

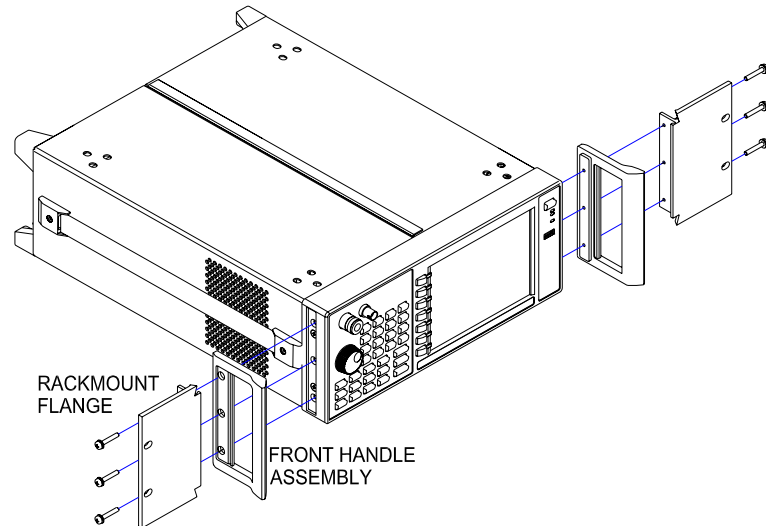

- 4 Attach the spectrum analyzer to the rack using the rackmount flanges with two dress screws per side.

CAUTION

Installing the spectrum analyzers into other racks may promote shock hazards, overheating, dust contamination, and inferior system performance. Consult your Agilent customer engineer about installation, warranty, and support details.

Electrostatic Discharge Protection

Electrostatic discharge (ESD) damages or destroys electronic components (the possibility of unseen damage caused by ESD is present whenever transported, stored, or while the instrument is in use).

This product contains components that are easily damaged by electrostatic discharge. To help reduce the possibility of ESD damage that can occur while using test equipment, follow these guidelines:

- 1** Before connecting any coaxial cable to the spectrum analyzer connector for the first time each day, momentarily short the center and outer conductors of the cable together to eliminate any potential electrostatic charges that may exist.
- 2** Personnel should be grounded with an approved type, 1 M Ω resistor-isolated ESD wrist-strap before touching the center pin of any connector, and before removing any assembly from the spectrum analyzer.
- 3** Be sure that all instruments are properly earth grounded to prevent build-up of static charges.

For more information about ESD and how to prevent ESD damage, contact the Electrostatic Discharge Association (<http://www.esda.org>). The ESD standards developed by this agency are sanctioned by the American National Standards Institute (ANSI).

BSA PC software

Agilent HSA PC software is an easy-to-use, PC-based remote control tool for the N9322C spectrum analyzer.

It is able to be discretely used as a spectrum monitor to display and control the trace scans simultaneously with the analyzer, or a file manager to send/get files between the analyzer and PC. It also provides some data analysis function for your further use.

You can get this software in the Help Kit CD, or download from <http://www.agilent.com/find/n9322c>.

NOTE

To connect the analyzer via the USB/LAN port to a PC, no extra driver is required. All you need is the Agilent IO libraries suite, which is in the Help kit CD shipped with your analyzer, or download the IO libraries suite from <http://www.agilent.com/find/iolib>

For the further description of the BSA PC software, please refer to the online help embedded in this software.

Helpful Tips

The following contains information to help in using and maintaining the instrument for optimum operation, including alignment, external reference, firmware update and option activation.

Perform Calibration

The N9322C provides three manual calibration function to calibrate the time base and amplitude. The analyzer should warm up for 30 minutes before calibration.

Time Base Calibration

Perform a time base calibration to guarantee the frequency accuracy. The analyzer should warm up for approximately 30 minutes before calibration.

When the calibration is triggered, the current measurement is interrupted and a gauge displays on the LCD. The gauge simply indicates calibration is in process. When it is finished, the interrupted measurement restarts.

Please refer to the operation procedures as below:

- 1 Input a 10 MHz, 0 dBm signal to **EXT TRIG IN**.
- 2 Press **[System] > Service > Calibration > Time Base by Ext** to initiate the calibration.

Time base calibration takes only a short time when the inner temperature is stable. When the inner temperature is increasing, calibration takes a long period of time or will fail. If the input reference signal is abnormal, the calibration cycle will take a long and unpredictable time to exit, and the LCD displays an error message.

Amplitude Calibration

The analyzer provides the internal amplitude calibration function. Please refer to the procedures below to perform an amplitude calibration:

- 1 Press **[System] > More > Service > Calibration > Amp Alignment**
- 2 Connect the CAL OUT and RF IN connector with a N-BNC cable. Then Press **[Enter]** to continue.

The calibration will start immediately. The calibration will be completed in several minutes.

Using an External Reference

To use an external 10 MHz source as the reference frequency, connect the external reference source to the **REF IN** connector on the rear panel. An **EXT REF** indicator will display in the upper bar of the display. The signal level must be in the range of -5 to $+10$ dBm. When the reference signal is ready, the instrument switches the reference from time base to the external reference.

Enable an Options

Option license key information is required to enable product options. Contact your nearest Agilent office for purchasing a license. Refer to the procedures below to activate the options you have purchased.

- 1 Press **[System] > More > Service > Add Option**
- 2 Enter the option number to be enabled. Press **[Enter]** to confirm your input.
- 3 Enter the license key in the onscreen window. Press **[Enter]** to confirm your input and terminate the license key input.
- 4 Press **Activate License**. The option will be enabled immediately.

The analyzer provides the trial license with limited time usage(15/270/365 days) of the wanted options.

Firmware Upgrade

Press **[System] > System Info > Show system** to view the firmware revision. If you call Agilent Technologies regarding your analyzer, it is helpful to have this revision and the analyzer serial number available.

Follow this procedure to finish the firmware update:

- 1 Download the firmware package from www.agilent.com/find/n9322c. Extract and copy the file to the folder “**N932xDATA**” into the root directory of a USB stick.
- 2 Plug the USB stick into the connector. Press **[System] > Service > Upgrade Firmware**

The analyzer will perform the update process automatically. The upgrade procedure will take several minutes. Once the upgrade is completed, please follow the instruction to reboot.

CAUTION

Any interruption during the update process will result in update failure and system data lost. Do not remove the USB storage device until the update is finished.

IO Configuration

The N9322C spectrum analyzer provides three types of IO connection: USB, LAN and optional GPIB interface. Press **[System] > More > Port Setting** to set the corresponding interface as your need.

USB

Select USB to enable the USB connection for remote control.

LAN

The N9322C supports LAN port connection for remote control. Press **[System] > {More} > {Port Setting} > {IP Config}** to set the IP parameters for the network connection.

Press **{IP Address Static}** to manually set the IP address, gateway and subnet mask with the proper LAN information, or just press **{IP Address DHCP}** to set the IP address in LAN dynamically according DHCP.

Press **{Apply}** to enable the LAN connection according to the IP configuration you set.

GPIB

Press **[System] > {More} > {Port Setting} > {GPIB Address}** to set the GPIB address for the analyzer. This softkey is only valid after the option G01 is installed.

Timed Power On/Off

Pressing **[System] > {Power On/Off Preset} > {Timed Pwr On}** or **{Timed Pwr Off}** sets the time switch to power on/off the N9322C in a user-defined time and date. This function requires the power supply connected.

Press **{Repeat Mode Once/Everyday}** to set the N9322C boot up/off in the pre-saved time everyday. The pre-saved date is invalid in this mode.

Power Preset Last

Press **[System] > {Pwr On/Preset} > {Power On Last}** to activate this function. For the standard N9322C, this operation only save the last state if the analyzer is turned off by the front panel power switch.

Data Securities

The N9322C offers the optional memory erase function for data security. Press **[System] > {More} > {Securities} > {Erase Memory}** to erase all the user data in internal memory. Press Enter as a terminator to start the erase process immediately.

The memory erase process takes about 15 minutes. During the time, there must be a constant power supply to ensure the successful erase. If the erase process is interrupted, please reboot the instrument and erase memory again.

Probe Power Output

The Probe Power provides power for high-impedance AC probes or other accessories (+15 V, -12V, 150 mA maximum).

The Probe Power is set to off as default. Press **[System] > {More} > {Port Setting} > {Probe Power On}** to switch on the probe power output.

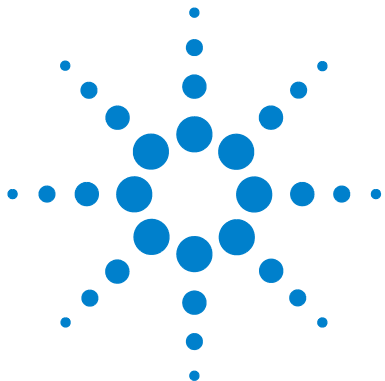

3 Functions and Measurements

Making a Basic Measurement	30
Measuring Multiple Signals	35
Measuring a Low-Level Signal	44
Improving Frequency Resolution and Accuracy	49
Tracking Drifting Signals	51
Making Distortion Measurements	53
Stimulus Response Transmission	59
Measuring Stop Band Attenuation of a Lowpass Filter	61
Channel Scanner	64
Spectrum Monitor	69
Reflection Measurement	71
Making a Power Measurement with USB Power Sensor	74
Demodulate the AM/FM signal	84
Analysis the Modulated Signals	87
Measuring Channel Power	93
Files Operation	95

This chapter provides information on the analyzer functions and specific measurements capabilities of the spectrum analyzer.



Making a Basic Measurement

This section provides information on basic operations. It assumes that you are familiar with the front and top panel buttons and keys, and display annotations of your analyzer. If you are not, please refer to “[Front Panel Overview](#)” on page 4 and “[Rear Panel Overview](#)” on page 9.

For more details on making measurements, please refer to “[Key Reference](#)” on page 101”.

Using the Front Panel

This section provides you with the information on using the front panel of the spectrum analyzer.

Entering Data

When setting the measurement parameters, there are several ways to enter or modify the value of the active function:

- Knob** Increments or decrements the current value.
- Arrow Keys** Increments or decrements the current value by a step unit.
- Numeric Keys** Enters a specific value. Then press the desired terminator (either a unit softkey, or **[Enter]** hardkey).
- Unit Softkeys** Terminate (enter) a value with a unit softkey from the menu.
- Enter Key** Terminates an entry when no unit of measure is required, or the instrument uses the default unit.
- ESC Key** To delete the current input digit prior to entering the value.

Using Softkeys

Softkeys are used to modify the analyzer function parameter settings. Some examples of softkey types are:

- Toggle** Turn on or off an instrument state.
- Submenu** Displays a secondary menu of softkeys, **{More}**.
- Choice** Selecting from a list of standard values or filenames.
- Adjust** Highlights the softkey and sets the active function.

Presetting the Spectrum Analyzer

Preset function provides a known instrument status for making measurements. There are two types of presets, factory and user:

Factory Preset When this preset type is selected, it restores the analyzer to its factory-defined state. A set of known instrument parameter settings defined by the factory.

User Preset Restores the analyzer to a user-defined state. A set of user defined instrument parameter settings saved for assisting the user in quickly returning to known a instrument measurement setup.

Press **System > Pwr on/Off Preset > Preset Type** to select the preset type.

When **Preset Type** is set to **Factory**, pressing **Preset** triggers a factory preset condition. The instrument will immediately return to the factory default instrument parameter setting.

When **Preset Type** is set to **User**, pressing **Preset** triggers a user preset condition. The instrument will immediately return to the user defined instrument parameter setting.

When **Preset Type** is set to **Last**, pressing **Preset** triggers a last power-off condition. The instrument will immediately return to the parameter setting when it is power off last time.

Setting up a User Preset

To quickly return to instrument settings that are user defined, perform the following steps to save the instrument state as the user-defined preset:

- 1 Set the instrument parameters to the values and settings necessary for the user preset state. This would include the frequency, span, amplitude, BW, and measurement type and any other setup details desired.

- 2 Press **System > Pwr on/off Preset > Save User**, to save the current instrument settings as the 'user preset' state. The user preset will not affect the default factory preset settings. User preset settings can be changed and saved at any time.

Figure 3-1 Factory Default Preset Setting

Attenuation	20 dB(Auto)	Average Type	Log Pwr
Center frequency	3.5 GHz	Average Number	100 (Off)
Reference offset	0 dB	Peak Excursion	6 dB
Start Frequency	0 Hz	Peak Threshold	-140 dBm
Stop Frequency	7 GHz	Peak Search Type	Max
Hi-Sensitivity	Off	Continuous Pk	Off
Span	7 GHz	Graticule	On
Reference level	0 dBm	Y Scale	On
Log scale/Division	10 dB	Cal Out	Off
Int Preamp	Off	Probe Power	Off
Trace 1	Clear Write	Trigger	Free Run
Trace 2, 3, 4	Blank	Marker Mode	Normal
Sweep Time	328.5 ms(Auto)	Marker Function	Normal
Sweep	Continuous	Marker Table	Off
Limit Line	Off	Measure	Meas Off
Limit	Off	File Catalog	Int
Impedance	50 Ω	File Sort	By Date
Detector	Pos Peak	Gated Sweep	Off
Display line	Off	Gate Delay	12 μ s
Video bandwidth	3 MHz(Auto)	Gate Length	84 μ s
VBW/RBW ratio	1.000 (Auto)	Gate Source	External
Resolution bandwidth	3 MHz(Auto)	Sweep Time Rule	Speed

Viewing a Signal

Refer to the procedures below to view a signal.

- 1 Press **System > Pow on/off Preset > Preset Type > Factory** to enable the factory-defined preset state.
- 2 Press **Preset** to restore the analyzer to its factory-defined state.
- 3 Connect the 10 MHz **REF OUT** on the rear panel to the front-panel **RF IN**.

Setting the Reference Level and Center Frequency

- 1 Press **Amplitude > 10 > dBm** to set 10 dBm reference level.
- 2 Press **Frequency > 30 > MHz** to set 30 MHz to center frequency.

Setting Frequency Span

Press **Span > 50 > MHz** to set 50 MHz frequency span.

NOTE

Changing the reference level changes the amplitude value of the top graticule line. Changing the center frequency changes the horizontal placement of the signal on the display. Increasing the span will increase the frequency range that appears horizontally across the display.

Reading Frequency and Amplitude

- 1 Press **Peak Search** to place a marker (labeled 1) on the 10 MHz peak.

Note that the frequency and amplitude of the marker appear both in the active function block, and in the upper-right corner of the screen.

Figure 3-1 10 MHz Internal Reference Signal

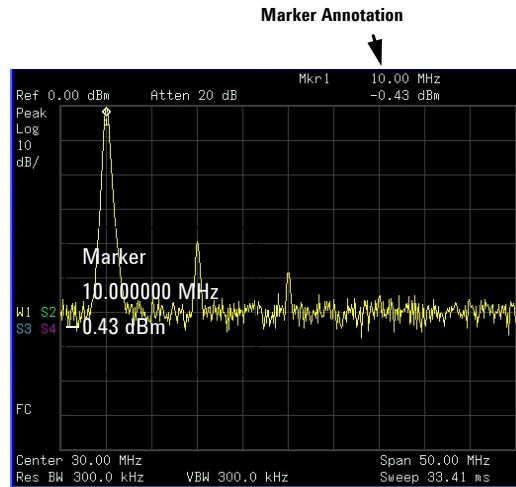

- 2 Use the knob, the arrow keys, or the softkeys in the **Peak Search** menu to move the marker. The marker information will be displayed in the upper-right corner of the screen.

Changing Reference Level

- 1 Press **Amplitude** and note that reference level (**Ref Level**) is now the active function.
- 2 Press **Marker > Marker To > Mkr-> Ref Lvl.**

NOTE

Changing the reference level changes the amplitude value of the top graticule line.

Measuring Multiple Signals

This section provides the information on how to measure multiple signals.

Comparing Signals on the Same Screen Using Marker Delta

The delta marker function allows the user to compare two signals when both appear on the screen at the same time.

In the following example, harmonics of the 10 MHz reference signal available are used to measure frequency and amplitude differences between two signals on the same screen. Delta marker is used to demonstrate this comparison.

- 1 Preset the analyzer:
Press **Preset** (With **Preset Type** of **Factory**)
- 2 Connect the rear panel **REF OUT** to the front panel **RF IN**.
- 3 Set the analyzer center frequency, span and reference level to view the 10 MHz signal and its harmonics up to 50 MHz:
Press **Frequency > 30 > MHz**
Press **Span > 50 > MHz**
Press **Amplitude > 10 > dBm**
- 4 Place a marker at the highest peak on the display (10 MHz):
Press **Peak Search**
The marker should be on the 10 MHz reference signal. Use the **Next Right Pk** and **Next Left Pk** softkeys to move the marker from peak to peak.
- 5 Anchor the first marker and activate a second marker:
Press **Marker > Mode > Delta**
The label on the first marker now reads 1R, indicating that it is marking the reference point.

- 6 Move the second marker to another signal peak using the front-panel knob or by using **Peak Search**.

Press **Peak Search > Next Peak** or

Press **Peak Search > Next Right Pk** or **Next Left Pk**. Continue pressing the **Next Pk** softkeys until the marker is on the correct signal peak.

The amplitude and frequency differences between the markers are displayed in the active function block.

Figure 3-2 Delta pair marker with signals on the same screen

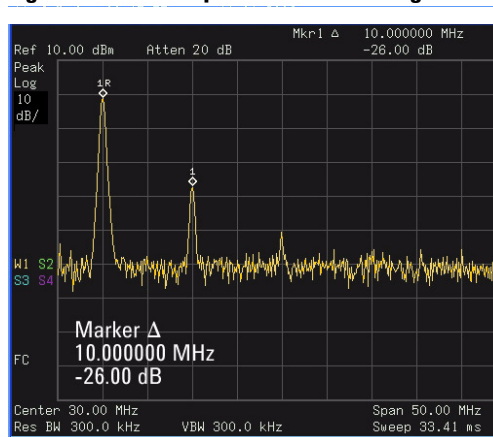

NOTE

To increase the resolution of the marker readings, turn on the frequency count function. For more information, refer to [“Improving Frequency Resolution and Accuracy”](#) on page 49.

Comparing Signals not on the Same Screen Using Marker Delta

The analyzer will compare the frequency and amplitude differences between two signals which are not displayed on the screen at the same time. (This technique is useful for harmonic distortion tests.)

In this example, the analyzer's 10 MHz signal is used to measure frequency and amplitude differences between a signal on screen, and another signal off screen. Delta marker is used to demonstrate this comparison.

- 1 Preset the analyzer:
Press **Preset** (With **Preset Type** set to **Factory**)
- 2 Connect the rear panel **REF OUT** to the front panel **RF IN**.
- 3 Set the center frequency, span and reference level to view only the 50 MHz signal:
Press **Frequency > 50 > MHz**
Press **Span > 25 > MHz**
Press **Amplitude > 10 > dBm**
- 4 Place a marker on the 50 MHz peak and then set the center frequency step size equal to the marker frequency (10 MHz):
Press **Peak Search**
Press **Marker > Marker To > Mkr -> CF Step**
- 5 Activate the marker delta function:
Press **Marker > Mode > Delta**
- 6 Increase the center frequency by 10 MHz:
Press **Frequency**, 

The first marker moves to the left edge of the screen, at the amplitude of the first signal peak.

Figure 3-3 shows the reference annotation for the delta marker (1R) at the left side of the display, indicating that the marker set at the 50 MHz reference signal is at a lower frequency than the frequency range currently displayed.

Figure 3-3 Delta Marker with Reference Signal Off-Screen

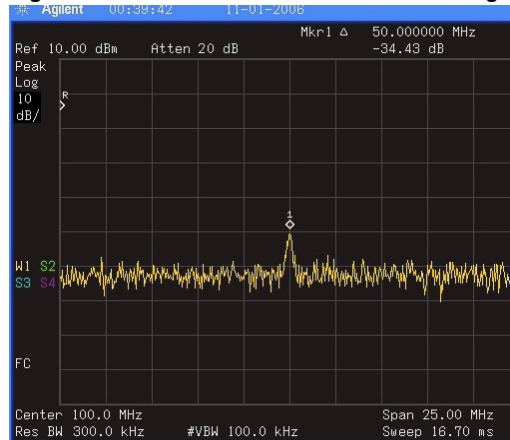

The delta marker appears on the peak of the 100 MHz component. The delta marker annotation displays the amplitude and frequency difference between the 50 and 100 MHz signal peaks.

- 7 Press **Marker > Mode > Off** to turn the markers off.

Resolving Signals of Equal Amplitude

In this example a decrease in the resolution bandwidth (RBW) is used in combination with a decrease in video bandwidth (VBW) to resolve two signals of equal amplitude with a frequency separation of 100 kHz.

Figure 3-4 Setup for obtaining two signals

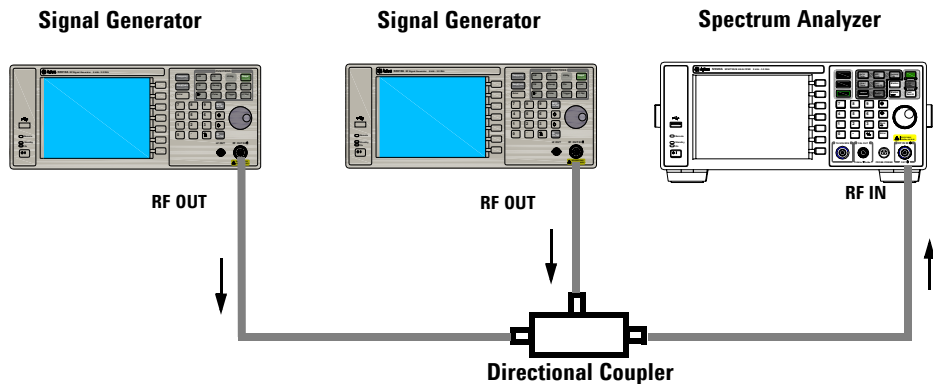

Notice that the final RBW selection to resolve the signals is the same width as the signal separation while the VBW is slightly narrower than the RBW.

- 1 Connect two sources to the analyzer input as shown above.
- 2 Set one source to 300 MHz. Set the frequency of the other source to 300.1 MHz. Set both source amplitudes to -20 dBm.
- 3 Setup the analyzer to view the signals:

Press **Preset** (With **Preset Type** of **Factory**)

Press **Frequency > 300 > MHz**

Press **BW > 300 > kHz**

Press **Span > 2 > MHz**

A single signal peak is visible. See [Figure 3-5](#) for example.

If the signal peak is not present on the display, increase the frequency span out to 20 MHz, turn signal tracking on, decrease the span back to 2 MHz and turn signal tracking off:

Press **Span > 20 > MHz**

Press **Peak Search**

Press **Span > 2 > MHz**

Figure 3-5 Unresolved Signals of Equal Amplitude

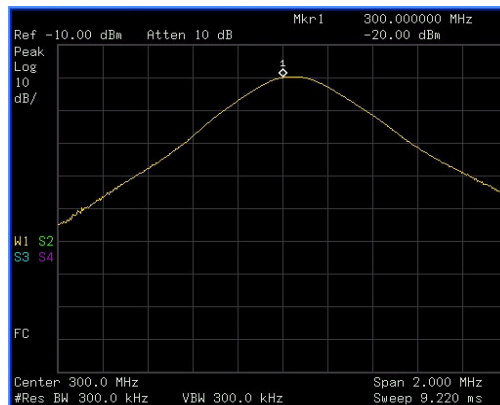

- 4 Change the resolution bandwidth (RBW) to 100 kHz so that the RBW setting is less than or equal to the frequency separation of the two signals:

Press **BW > 100 > kHz**

Notice that the peak of the signal has become flattened indicating that two signals are present.

- 5 Decrease the video bandwidth to 3 kHz:

Press **BW > Video BW > 3 > kHz**

Two signals are now visible as shown in [Figure 3-6](#). Use the front-panel knob or arrow keys to further reduce the resolution bandwidth and better resolve the signals.

Decreasing the resolution bandwidth improves the resolution of the individual signals and increases the sweep time.

Figure 3-6 Resolving Signals of Equal Amplitude

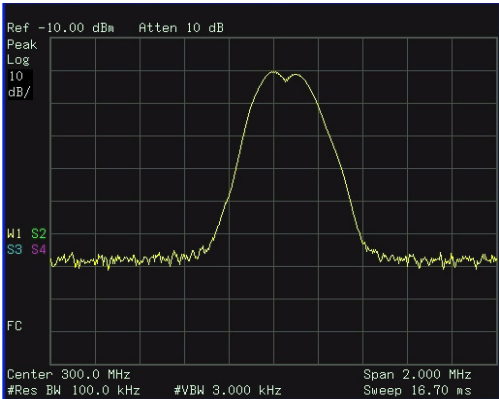

For fastest measurement times, use the widest possible resolution bandwidth. Under factory preset conditions, the resolution bandwidth is coupled to the span.

Resolving Small Signals Hidden by Large Signals

This example uses narrow resolution bandwidths to resolve two RF signals that have a frequency separation of 50 kHz and an amplitude difference of 60 dB.

- 1 Connect two sources to the **RF IN** as shown in [Figure 3-4](#).
- 2 Set one source to 300 MHz at -10 dBm. Set the other source to 300.05 MHz at -70 dBm.
- 3 Set the analyzer as follows:
 Press **Preset**. (With **Preset Type** of **Factory**)
 Press **Frequency > 300 > MHz**
 Press **BW > 30 > kHz**
 Press **Span > 500 > kHz**
- 4 Set the 300 MHz signal to the reference level:
 Press **Peak Search**
 Press **Marker > Mode > Mkr -> Ref Lvl**

NOTE

The 30 kHz filter shape factor of 15:1 has a bandwidth of 450 kHz at the 60 dB point. The half-bandwidth (225 kHz) is NOT narrower than the frequency separation of 50 kHz, so the input signals can not be resolved.

Figure 3-7 Unresolved small signal from large signal

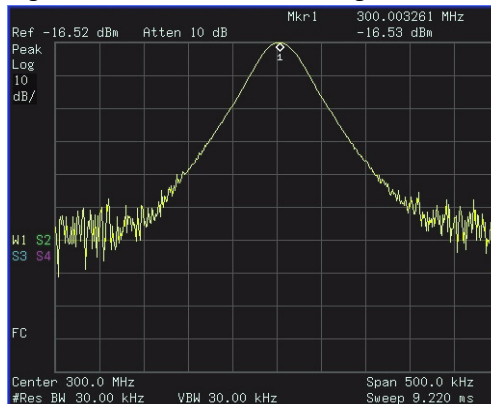

- 5 Reduce the resolution bandwidth filter to view the smaller signal. The smaller signal will be hidden by the larger signal when the bandwidth settings are wider. Reducing the RBW setting will allow less of the larger signal to pass through the analyzer and the smaller signals peak will then rise out of the noise floor. Place a delta marker on the smaller signal:

Press **BW > 1 > kHz**

Press **Peak Search**

Press **Marker > Mode > Delta**

Press **50 > kHz**

Figure 3-8 Resolved small signal from large signal

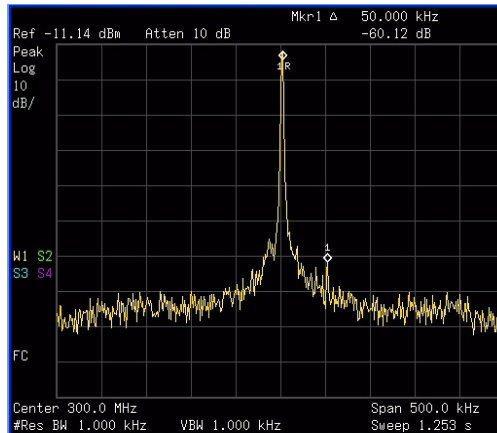

NOTE

The 1 kHz filter shape factor of 15:1 has a bandwidth of 15 kHz at the 60 dB point. The half-bandwidth (7.5 kHz) is narrower than the frequency separation of 50 kHz, so the input signals can be resolved.

Measuring a Low-Level Signal

This section provides information on measuring low-level signals and distinguishing them from spectrum noise.

Reducing Input Attenuation

The ability to measure a low-level signal is limited by internally generated noise of the spectrum analyzer. The analyzer's input attenuator affects the level of a signal passing through the analyzer. If a signal power level is close to the noise floor, reducing the analyzer input attenuation will help raise the signal so that it can be seen rising out of the noise.

CAUTION

Ensure that the total power of all input signals at the analyzer RF input does not exceed +30 dBm (1 Watt).

- 1 Preset the analyzer
Press **Preset** (With **Preset Type** of **Factory**)
 - 2 Set the source frequency to 300 MHz, amplitude to -70 dBm.
Connect the source **RF OUT** to the analyzer **RF IN**.
- Figure 3-9 Setup for obtaining one signal**

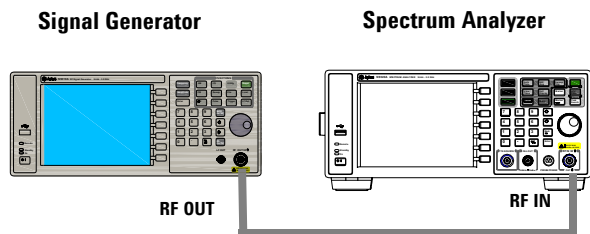

- 3 Set the center frequency, span and reference level:
 Press **Frequency > 300 > MHz**
 Press **Span > 2 > MHz**
 Press **Amplitude > 40 > -dBm**.
- 4 Move the desired peak to the center of the display:
 Press **Peak Search**
 Press **Marker > Marker To > Mkr -> CF**
- 5 Reduce the span to 500 kHz, if necessary re-center the peak:
 Press **Span > 500 > kHz**
- 6 Set the attenuation to 20 dB:
 Press **Amplitude > Attenuation > 20 > dB**

Figure 3-10 A signal closer to the noise level

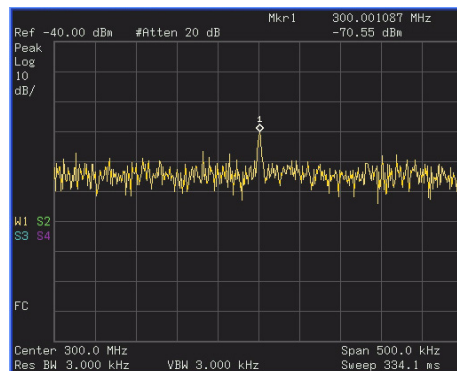

Note that increasing the attenuation moves the noise floor closer to the signal level.

- 7 To allow more of the signal power to pass through the analyzer, decrease the attenuation to 0 dB.

A lower attenuation value will mean that more of the signal strength will be displayed on screen:

Press **Amplitude > Attenuation > 0 > dB**

Figure 3-11 Measuring a low-level signal using 0 dB Attenuation

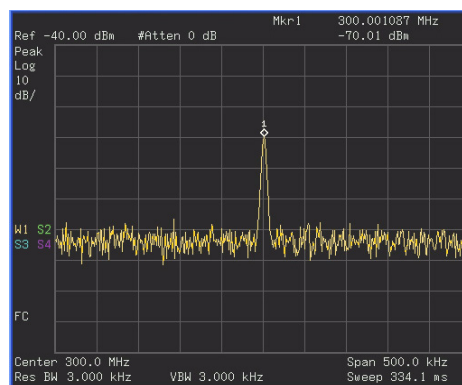

Decreasing the Resolution Bandwidth

Resolution bandwidth settings affect the level of internal noise but have little effect on the displayed level of continuous wave (CW) signals. Decreasing the RBW by a decade (factor of ten) reduces the noise floor by 10 dB.

- 1 Refer to the procedure “[Reducing Input Attenuation](#)” on page 44 and follow steps 1, 2 and 3.
- 2 Decrease the resolution bandwidth:

Press **BW** and 

The low-level signal appears more clearly due to the noise level being reduced by the decrease in RBW (see [Figure 3-12](#)).

Figure 3-12 Decreasing Resolution Bandwidth

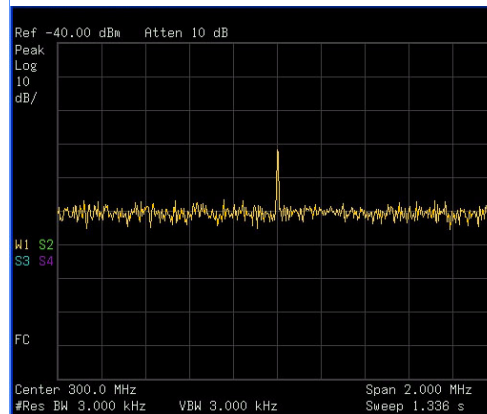

A “#” mark appears next to the Res BW annotation in the lower left corner of the screen, indicating that the resolution bandwidth is uncoupled.

Uncoupled indicates that the function is in manual control mode, not auto control mode. Manual control mode allows the user to change the parameter value for that function without affecting any other settings.

NOTE

The analyzer allows you to change the RBW in a 1-3-10 sequence by the data control keys. The RBWs below 1 kHz are digital and have a selectivity ratio of 5:1 while RBWs at 1 kHz and higher have a 15:1 selectivity ratio. The maximum RBW is 3 MHz and minimum is 10 Hz.

Trace Averaging

Averaging is a digital process in which each sweep of the trace returns measurement values for each point in the trace. These values are then mathematically averaged with the previous sweep trace data which has been stored in the analyzer. The amount of averaging is selected by choosing the number of trace sweeps to be included in the process. The averaging function uses the most recent trace sweep values so that the display shows any signal changes.

Selecting averaging, when the analyzer is auto-coupled, changes the detection mode to **Sample**, smoothing the displayed noise level.

NOTE

This is a trace processing function and is not the same as using the average detector (as described on [page 47](#)).

1 Refer to the procedure “[Reducing Input Attenuation](#)” on page 44 of this chapter and follow steps 1, 2 and 3.

2 To turn averaging on, toggle the softkey menu labeled **Average**:

Press **BW > Average (On)**

3 Set the number of averages to 20, using the number keypad, up and down arrows, or the knob:

Press **20, Enter**

The averaging process smooths the viewed trace, low level signals become more visible (see [Figure 3-13](#)). Changes to the average number will restart the averaging process.

Figure 3-13 Trace Averaging

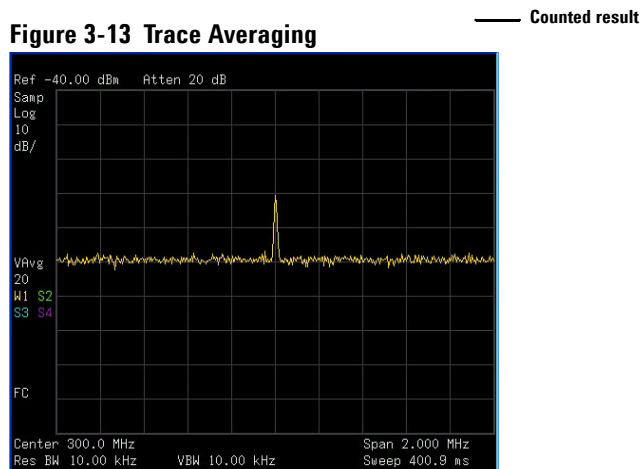

Improving Frequency Resolution and Accuracy

This section provides information on using the frequency counter function to improve frequency resolution and accuracy.

- 1 Press **Preset** (With **Preset Type** of **Factory**)
- 2 Connect a cable from the front panel **CAL OUT** to **RF IN**;
Press **System > Service > Calibration > CAL OUT ON** to toggle on and enable the 50 MHz amplitude reference signal.
- 3 Press **Frequency > Auto Tune**.

The analyzer will detect the signal peak and locate it to the center of the display (Refer to “Auto Tune” on page 111).

- 4 Turn the frequency counter on:
Press **Marker > Function > Counter**.
- 5 Move the marker, with the front-panel knob, half-way down the skirt of the signal response.

Figure 3-14 Using Frequency Counter

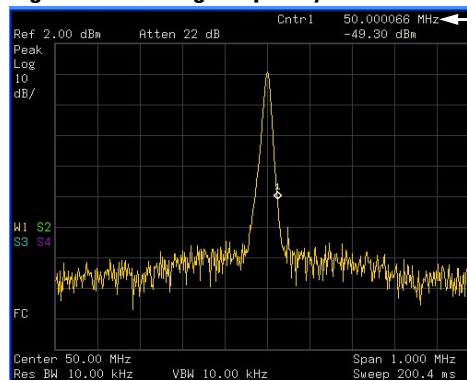

NOTE

The frequency and amplitude of the marker appears in the active function area (this is not the counted result). The counted result appears in the upper-right corner of the display to the right-side of C1.

The marker readout in the active frequency function changes while the counted frequency result (upper-right corner of display) does not. For an accurate count, the marker need not be placed at the exact peak of the signal response.

NOTE

The Frequency counter properly functions only on stable, CW signals or discrete spectral components. The marker power level must be greater than 40 dB above the displayed noise level.

6 To turn off the marker counter:

Press **Marker > Function > Off**.

NOTE

When using the frequency counter function, the ratio of the resolution bandwidth to the span must be greater than 0.02.

Tracking Drifting Signals

This section provides information on measuring and tracking signals that drift in frequency.

Measuring a Source's Frequency Drift

The analyzer will measure source stability. The maximum amplitude level and the frequency drift of an input signal trace can be displayed and held by using the maximum hold function. Using the maximum hold function you can measure and determine how much of the frequency spectrum a signal occupies. For more information, refer to “[Max Hold](#)” on page 162.

Use signal tracking to return a signal drifting in frequency to the center of the display. The drifting is captured by the analyzer using the maximum hold function.

- 1 Connect the signal generator to the analyzer **RF IN**.
- 2 Output a signal with the frequency of 300 MHz and amplitude of -20 dBm.
- 3 Set the analyzer center frequency, span and reference level.
 Press **Preset**. (With **Preset Type** of **Factory**)
 Press **Frequency > 300 > MHz**
 Press **Span > 10 > MHz**
 Press **Amplitude > -10 > dBm**
- 4 Place a marker on the peak of the signal:
 Press **Peak Search**
 Press **Marker > Marker To > Marker to Center**
 Press **Span > 1 > MHz**
 The signal is in the center of the display.
- 6 Measure the excursion of the signal with maximum hold:
 Press **Trace/Det > Max Hold**

As the signal varies, maximum hold maintains the maximum responses of the input signal. Annotation on the left side of the screen indicates the trace mode. For example, M1 S2 S3 S4, indicates trace 1 is in maximum-hold mode, trace 2, trace 3, and trace 4 are in store-blank mode.

- 7 Activate trace 2 and change the mode to continuous sweep:
Press **Trace/Det > Select Trace > Trace 2**

Press **Clear Write**

Trace 1 remains in maximum hold mode to show any drift in the signal.

- 8 Slowly increase the frequency of the signal generator. Your analyzer display should look similar to [Figure 3-15](#).

Figure 3-15 Viewing a Drifting Signal With Max Hold and Clear Write

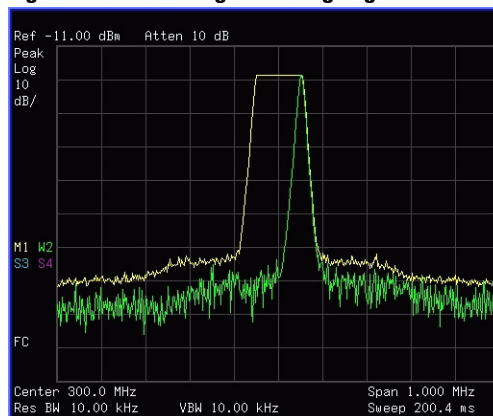

Making Distortion Measurements

This section provides information on measuring and identifying signal distortion.

Identifying Analyzer Generated Distortion

High-level input signals may cause analyzer distortion products that could mask the real distortion measured on the input signal. Use trace and the RF input attenuator to determine which signals, if any, are internally generated distortion products.

In this example, we use the RF output of a signal generator to determine whether the harmonic distortion products are internally generated by the analyzer.

- 1 Connect the signal generator to the analyzer **RF IN**.
- 2 Set the source frequency to 200 MHz, amplitude to 0 dBm.
- 3 Set the analyzer center frequency and span:

Press **Preset**

Press **Frequency > 400 > MHz**

Press **Span > 500 > MHz**

Figure 3-16 Harmonic Distortion

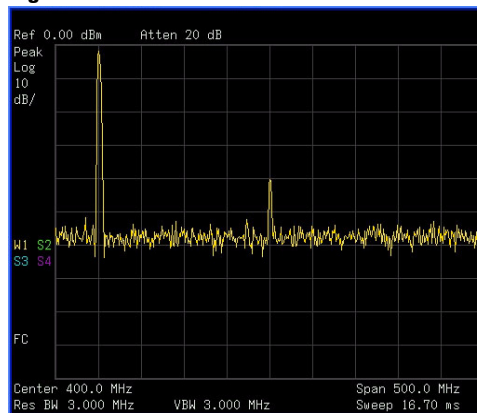

The signal produces harmonic products (spaced 200 MHz from the original 200 MHz signal) in the analyzer input mixer as shown in [Figure 3-16](#).

- 4 Change the center frequency to the value of the first harmonic:
Press **Peak Search > Next Peak**
Press **Marker > Marker To > Mkr -> CF**
- 5 Change the span to 50 MHz and re-center the signal:
Press **Span > 50 > MHz**
Press **Peak Search**
Press **Marker > Marker To > Mkr -> CF**
- 6 Set the attenuation to 0 dB:
Press **Amplitude > Attenuation > 0 > dB**
- 7 To determine whether the analyzer generates harmonic distortion products, first display the trace data in trace 2 as follows:
Press **Trace/Det > Select Trace > Trace 2**
Press **Clear Write**
- 8 Allow trace 2 to update (minimum two sweeps), then store the data from trace 2 and place a delta marker on the harmonic of trace 2:
Press **Trace/Det > View**
Press **Peak Search**
Press **Marker > Mode > Delta**

The analyzer display shows the stored data in trace 2 and the measured data in trace 1. The **Marker Δ** indicator reads the difference in amplitude between the reference and active markers.
- 9 Increase the RF attenuation to 10 dB:
Press **Amplitude > Attenuation > 10 > dB**

Notice the **Marker Δ** amplitude readout. This is the difference of the distortion product amplitude between 0 dB and 10 dB input attenuation settings. If the **Marker Δ** absolute amplitude is approximately ≥ 1 dB for an input attenuator change, the analyzer is generating, at least in part, the distortion.

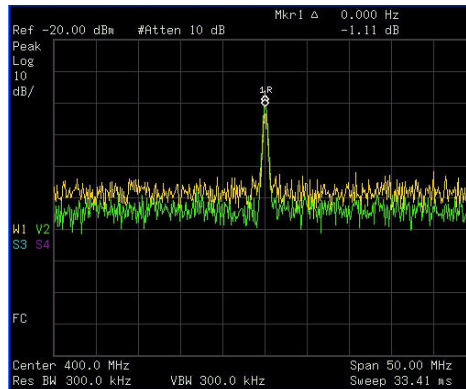

The **Marker Δ** amplitude readout comes from two sources:

- 1) Increased input attenuation causes poorer signal-to-noise ratio. This causes the **Marker Δ** to be positive.
- 2) The reduced contribution of the analyzer circuits to the harmonic measurement causes the **Marker Δ** to be negative.

Large **Marker Δ** readout indicates significant measurement errors. Set the input attenuator to minimize the absolute value of **Marker Δ** .

Third-Order Intermodulation Distortion

Two-tone, third-order intermodulation distortion is a common specification in communication systems. When two signals are present in a non-linear system, they may interact and create third-order intermodulation distortion (TOI) products that are located close to the original signals. System components such as amplifiers and mixers contribute to the generation of these distortion products.

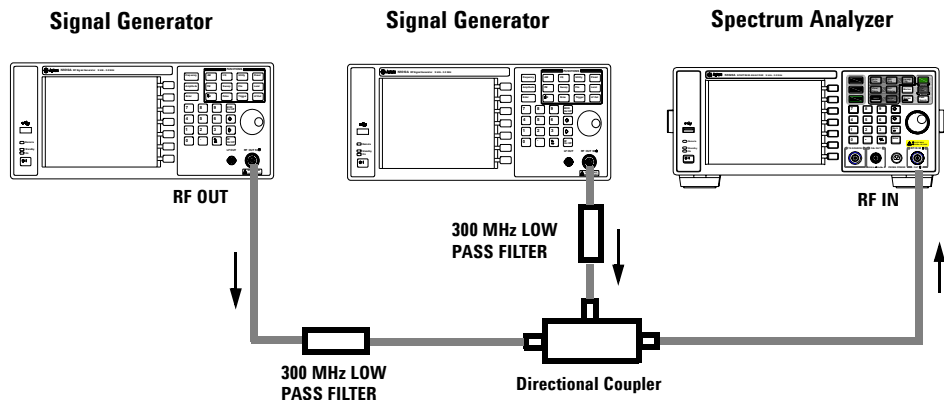

This example will test a device for third-order intermodulation through the use of markers. Two sources are used, one set to 300 MHz and the other to 301 MHz.

- 1 Connect the equipment as shown in figure below. This combination of signal generators, low pass filters, and directional coupler (used as a combiner) results in a two-tone source with very low intermodulation distortion. Although the distortion from this setup may be better than the specified performance of the analyzer, it is useful for determining the TOI performance of the source/analyzer combination. After the performance of the source/analyzer combination has been verified, the device-under-test (DUT) (for example, an amplifier) would be inserted between the directional coupler output and the analyzer input.



NOTE

The coupler should have a high degree of isolation between the two input ports so the sources do not intermodulate.

- 2 Set one source (signal generator) to 300 MHz and the other source to 301 MHz, for a frequency separation of 1 MHz. Set the sources equal in amplitude as measured by the analyzer (in this example, they are set to -5 dBm).
- 3 Set the analyzer center frequency and span:
 Press **Preset** (With **Preset Type** of **Factory**)
 Press **Frequency > 300.5 > MHz**
 Press **Span > 5 > MHz**
- 4 Reduce the RBW until the distortion products are visible:
 Press **BW** and 
- 5 Move the signal to the reference level:
 Press **Peak Search**
 Press **Marker > Marker To > Mkr -> Ref Lvl**
- 6 Reduce the RBW until the distortion products are visible:
 Press **BW** and 
- 7 Activate the second marker and place it on the peak of the distortion product (beside the test signal) using the **Next Peak**:
 Press **Marker > Mode > Delta**
 Press **Peak Search > Next Peak**
- 8 Measure the other distortion product:
 Press **Marker > Normal**
 Press **Peak Search > Next Peak**

- 9 Measure the difference between this test signal and the second distortion product (see Figure 3-17):

Press **Marker > Mode > Delta**

Press **Peak Search > Next Peak**

Figure 3-17 Measuring the Distortion Product

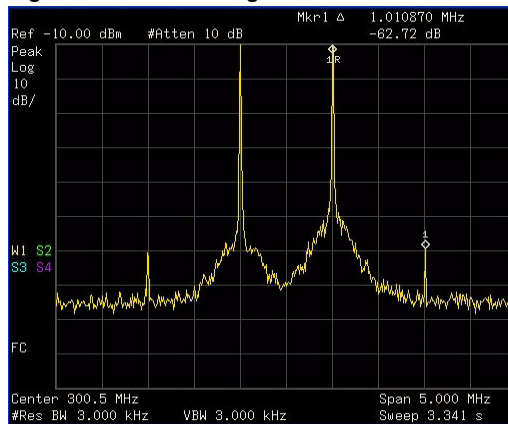

Stimulus Response Transmission

The procedure below describes using the built-in tracking generator of the analyzer to measure the rejection of a low pass filter. A type of transmission measurement.

- 1 To measure the rejection of a low pass filter, connect the equipment as shown in Figure 3-18. A 370 MHz low pass filter as the DUT.

Figure 3-18 Transmission Measurement Test Setup

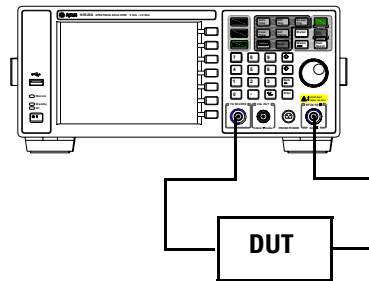

- 2 Press **Preset**. (With **Preset Type** of **Factory**)
- 3 Set the start and stop frequencies and resolution bandwidth:
Press **Frequency > Start Freq > 100 > MHz**
Press **Frequency > Stop Freq > 1 > GHz**
Press **Bw > 3 > MHz**
- 4 Turn on the tracking generator and if necessary, set the output power to -10 dBm:
Press **Mode > Tracking Generator > Amplitude (On) > -10 > dBm**

CAUTION

Excessive signal input may damage the DUT. Do not exceed the maximum power that the device under test can tolerate.

NOTE

To reduce ripples caused by source return loss, use 6 dB or greater output attenuation. Tracking generator output attenuation is normally a function of the source power selected. However, the output attenuation may be controlled in the Tracking Generator menu.

- 5 To increase measurement sensitivity and smooth the noise:
 Press **BW > 30 > kHz**
 Press **BW > Video BW > 300 > kHz**
 A decrease in displayed amplitude is caused by tracking error.
- 6 Connect the cable from the tracking generator output to the analyzer input. Store the frequency response in trace 3 and normalize:
 Press **Meas > Normalize > Store Ref (1 → 4) > Normalize (On)**
- 7 Reconnect the DUT to the analyzer and change the normalized reference position:
 Press **Meas > Normalize > Norm Ref Posn > 8**
- 8 Measure the rejection of the low pass filter:
 Press **Marker > 370 > MHz, Mode > Delta > 160 > MHz**
 The marker readout displays the rejection of the filter at 160 MHz above the cutoff frequency of the low pass filter. See [Figure 3-19](#) as below.

Figure 3-19 Measure the Rejection Range

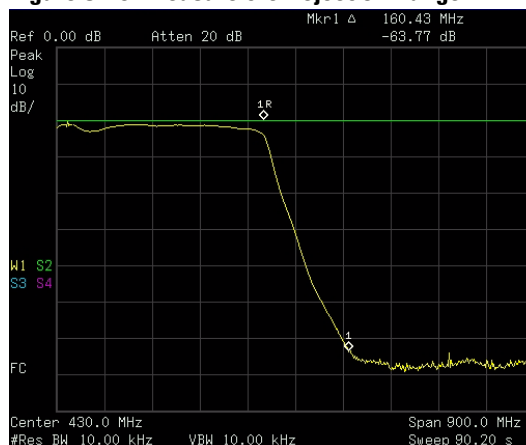

Measuring Stop Band Attenuation of a Lowpass Filter

When measuring filter performance, it is useful to look at the stimulus response over a wide frequency range. Setting the analyzer y-axis (amplitude) to Log scale type presents the measurement data in a usable format for determining filter characteristics.

The following example uses the tracking generator to measure the stop band attenuation of a 370 MHz low pass filter.

- 1 To measure the response of a low pass filter, connect the equipment as shown in [Figure 3-20](#). This example uses a 370 MHz low pass filter.

Figure 3-20 Transmission Measurement Test Setup

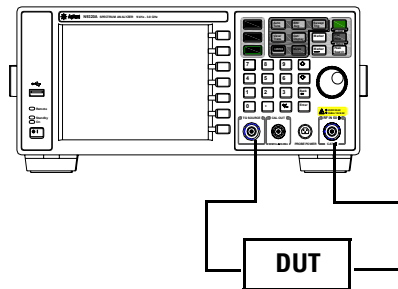

- 2 Press **Preset**. (With **Preset Type** of **Factory**)
- 3 Set the start and stop frequencies and resolution bandwidth:
 - Press **Frequency > Start Freq > 100 > MHz**
 - Press **Frequency > Stop Freq > 1 > GHz**
 - Press **Amplitude > Scale Type > Log**

- 4 Set the resolution bandwidth to 10 kHz:

Press **BW > 10 > KHz**

CAUTION

Excessive signal input may damage the DUT. Do not exceed the maximum power that the device under test can tolerate.

- 5 Turn on the tracking generator and, if necessary, set the output power to -10 dBm:

Press **Mode > Tracking Generator > Amplitude (On) > -10 > dBm**

- 6 Connect the test cable (but not the DUT) from the tracking generator output to the analyzer input. Store the frequency response into trace 3 and normalize:

Press **Meas > Normalize > Store Ref (1 → 4) > Normalize (On)**

- 7 Reconnect the DUT to the analyzer. Note that the units of the reference level have changed to dB, indicating that this is now a relative measurement.

- 8 To change the normalized reference position:

Press **Meas > Normalize > Norm Ref Posn > 8**

- 9 Place the reference marker at the specified cutoff frequency:

Press **Marker > Mode > Delta Pair (Ref) > 370 > MHz**

- 10 Place the second marker at 37 MHz:

Press **Delta Pair (Delta) > 37 > MHz**

- 11 In this example, the attenuation over this frequency range is -17.98 dB/octave (one octave above the cutoff frequency).

- 12 Use the front-panel knob to place the marker at the highest peak in the stop band to determine the minimum stop band attenuation. In this example, the peak occurs with Delta of 563 MHz. The attenuation is -60.93 dB. See Figure 3-21.

Figure 3-21 Minimum Stop Band Attenuation

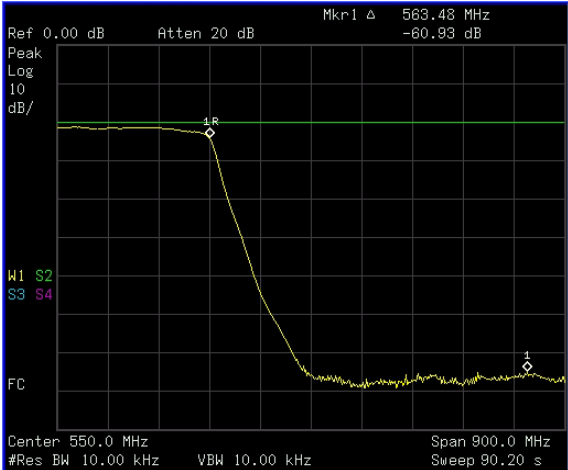

Channel Scanner

The channel scanner - option SCN is a tool for coverage test, band clearance, and spectrum monitoring. It measures the channel power of multiple transmitted channels. The power is displayed via either the graphic bar chart or time bar chart. It allows you to set maximum 20 channels for your test. You can continuously log the scanned channel data as CSV file for post processing on your PC.

Top/Bottom N Channel Scanner

Top/Bottom N channel scan is used for searching the top/bottom channels from specified channel range according channel power.

Figure 3-22 Top N Channel Scanner Measurement

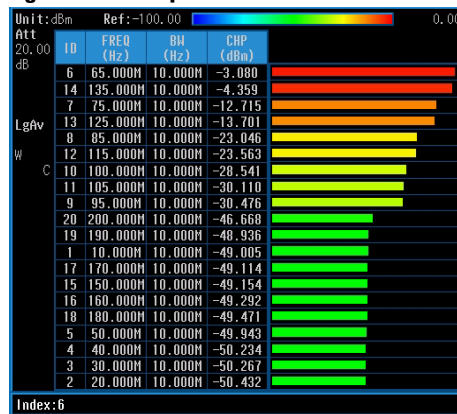

Please refer to the procedures below to perform a Top N channel scanner measurement.

- 1 Connect the antenna to RF IN connector.
- 2 Turn on the channel scanner function.

Press **Meas > Channel Scanner**

3 Press **Meas > Scan Mode > Top N** to set the scan mode to TOP N channel mode. Input the channel number you need to monitoring. Press **Enter** as a terminator.

4 Press **Range Edit** to access the submenu to edit the scan range.

Toggle **Edit Method** to underline **Std**. It allows you to set the range according to the embedded communication standard, such as CDMA and GSM which is used specifically in different countries. Press **Signal Std** to select the standard. Press **Recall** as a terminator. Press **Begin Chn** and **End Chn** to set the begin and end channel for scanning. Press **Apply** to apply all the range settings.

If you toggle **Edit Method** to underline **Custom**, it allows you to set the customer-defined scan as your need.

Press **Start Freq** to set the scan start frequency.

Press **Freq Step Size** to set the frequency interval for adjacent channels.

Press **Bandwidth** to set the bandwidth of each frequency channel which is used to calculate the channel power.

Press **Number of Chn** to set the number of frequency channels which will be scanned.

Press **Apply** as a terminator to apply all the settings above.

5 Press **Scan Start** to initiate the channel scan function.

6 Press **Logging Start** to start recording the scan process which includes the channel power and related channel bandwidth value to a CSV file. Press **Logging Stop** to end the logging. The CSVfile will be saved immediately.

List N Channel Scanner

The List N channel scan is used for listing the frequency channels from specific channel standard or customized frequency bandwidth.

Please refer to the procedures below to perform a List N channel scanner measurement.

1 Connect the antenna to RF IN connector.

2 Turn on the channel scanner function.

Press **Meas > Channel Scanner**}

3 Press **Meas > Scan Mode > List** to set the scan mode to List N channel mode. Input the channel number you need to monitoring. Press **Enter** as a terminator.

4 Press **List Edit** to access the submenu to edit the scan range.

Press **Insert** to insert a channel and access the channel setting submenu to customize the channel parameters.

Press **Edit Method Std.** It allows you to set the range according to the embedded communication standard, such as CDMA and GSM which is used specifically in different countries.

Press **Signal Std** to load a standard file as your need.

Please refer to [“Loading a File”](#) on page 98 for details.

Press **Chn ID** to select the specific channel according to the signal standard.

Or press **Edit Method Custom.** It allows you to set the customer-defined scan as your need.

Press **Freq** to set the center frequency of the current channel.

Press **Bandwidth** to set the bandwidth of each frequency channel which is used to calculate the channel power.

The first channel editing is completed. Press **Return > Insert** to add more channels as your need.

If there is a need to further edit the channel set previously, press **Index**, rotate the knob to highlight the channel as your need for further editing.

Press **Apply** as a terminator to apply all the settings above.

- 5 Press **Scan Start** to initiate the channel scan function.
- 6 Press **Logging Start** to start recording the scan process which includes the channel power and related channel bandwidth value to a CSV file. Press **Logging Stop** to end the logging. The CSV file will be saved immediately.

NOTE

Please make sure the file catalog is set to INT or USB unless the logging file can not be saved successfully. When the logging file exceeds the maximum volume of the storage catalog, the logging will automatically pause and the file will be saved immediately.

Display

In channel scanner mode, the **[Disp]** hardkey is used to adjust the channel scanner display to review the customized scan result.

Press **{Freeze}** to pause the display refresh but the scan is still running.

You can sort the channel by ID or power, in ascending or decending order. Or you can press **{Disp Mode}** to toggle the display mode between bar mode and time mode.

Figure 3-23 Time display mode in List N channel scanner

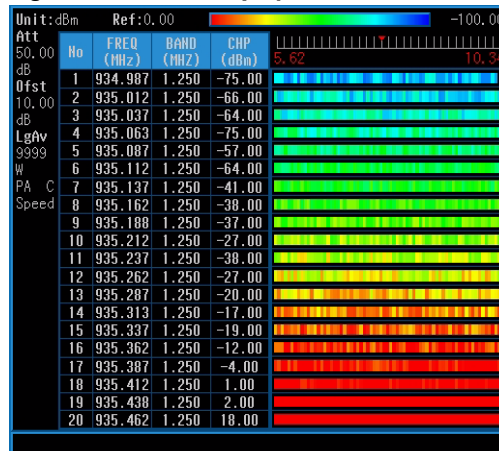

Channel Scanner Setup

To customized the channel scan process, you can press **Meas > Channel Scanner > Setup** to set the measurement interval and rule in the submenu.

The **Meas Interval** is a value of time/distance during which the every two scan process is triggered. When it is set to off, the channel will be scanned with default settings.

The **Interval Type** is toggled between time and distance. When it is set to **Time**, the minimum interval time is 100 ms. When it is set to **Distance**, it allows you to measure the channel with the specific distance on the road test. The minimum interval distance is 1 meter.

The **Measure Rule** and **Search Rule** is toggled between **Speed** and **Accuracy**.

For each scan process, the analyzer will first search and find out the available channels according to the selected scan mode. Then, a precise measurement will perform to get the scan result.

The accuracy mode in measurement rule is set as default to get the precise measurement for the searching-out channels.

The speed mode will speed the measurement but reduce the measurement accuracy. It is set to default in search rule to search out the available channels approximately.

The **Top Cycle** number is the searching times for each measurement. It allows you to measure the specific searching-out channels continuously.

Spectrum Monitor

The scrolling three-dimensional display is noted for its ability to track the frequency and power behavior over the time, particularly intermittent signals. Spectrum Monitor may be used to analyze the stability of a signal over the time, or to identify intermittent interference signals in communications systems.

The X-axis represents frequency, and amplitude is represented by color; red for a strong signal and blue for noise floor. The Y-axis represents time, with the trace from the newest sweep displayed at the bottom of the screen. Earlier traces move up toward the top with each new sweep. Two coupled markers allow the user to place a marker on any trace in the Spectrum Monitor and view the normal spectrum for the time of that sweep. The time interval between sweeps can be adjusted, and up to 1500 traces can be displayed and saved.

Figure 3-24 Spectrum Monitor Submenu

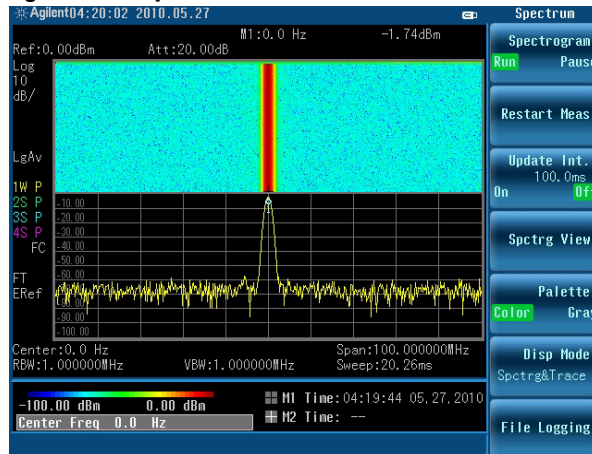

Please refer to the procedures below to perform a spectrum monitor measurement.

- 1 Connect the omni antenna to RF IN connector.
- 2 Set the center frequency and span.

Press **Frequency > 1.8052 > GHz**

Press **SPAN > 5 > MHz**

3 Turn on the spectrum monitor function.

Press **Meas > Spectrum Monitor**.

4 Set the update interval time between two frames.

Press **Update Int. On**, rotating the knob or pressing numeric keypads to set the update interval time.

5 Turn on Marker 1 and Marker 2.

Press **Marker 1 > State On, Marker 2 > State On**.

6 Press **Frequency**, rotate knob to change the frequency of marker as you want.

7 Press **Meas > File Logging > Start Save** to save the spectrogram data. After pressing **Stop Save**, the spectrogram will be saved into a trace or CSV data file for your future use.

Please refer to “[Loading a File](#)” on page 98 to load the saved spectrogram trace file.

Spectrum Monitor Audio Alert

The spectrum monitor provides an audio alert with a frequency dependant on the different control parameters. This alert needs two markers to specify the measure channel. The **Band Power** of the channel specified by two markers is measured without the audio alert. The **Alert Limit** is set to specify the lowest band power that makes the buzzer beep.

Please refer to the procedures below to turn on the audio alert.

1 Press **Meas > Spectrum Monitor** to access into the spectrogram mode.

2 Press **Marker > More > Audio Alert** to enable the audio alert.

Reflection Measurement

Press **MODE > Reflection Measurement** to access the cable and antenna measurement submenu. There are three different measurement mode for your selection:

- Reflection measurement
- One port cable loss
- Distance to fault

Preparation

Before making a measurement in a specific mode, the HSA requires a calibration to make sure the measurement accuracy. A new calibration must be performed if any components used in the calibration setup are changed. For example, a short coaxial cable used to connect the tester to the DUT

Press **Frequency** and **Span** to set the measurement frequency range. It is best to keep the calibration frequency range as close as possible to the actual sweep frequencies necessary for the measurements. Calibrating over a larger frequency range than the actual measurement range will reduce the accuracy of the test results.

Calibrate with a T-combo calibrator

T-combo calibrator This is a T-shaped mechanical calibrator. It consists of a calibrated open, short and 50 Ω load. Using the T-combo calibrator will result in a more accurate calibration than when using the an electronic calibrator.

Using a T-combo calibrator is a three step process requiring the user to manually change the open-short-load components. The default order of the calibration process is open-short-load.

1 Press **Frequency > Calibrate** to bring up the dialog box for calibration instruction. Follow the on-screen instruction to connect the Open component of the T-combo calibrator to

the RF OUT connector of the analyzer. Press **ENTER** to start the open calibration.

- 2 Follow the instruction to connect the short component of the T-combo calibrator to the RF OUT connector of the tester. Press **ENTER** to start the short calibration.
- 3 Connect the Load component of the T-combo calibrator to the RF OUT connector.
Press **ENTER** to start the load calibration.

A **Calibrated** indicator is shown on the upper left corner of the screen when the calibration is completed. Then, the analyzer is ready for your further cable measurement.

Measuring Cable Reflection

Press **Mode > Reflection Measurement > Reflection Measurement** to select the Reflection Measurement Mode. It allows you to set the Y axis of the graticule as return loss, VSWR or reflection coefficient value.

Measuring Distance to Fault

For this measurement, an internally generated signal emits from the RF OUT port of the tester and is transmitted to the cable and antenna system (DUT). The tester receives and processes the signal power reflected from faults and imperfections. In performing a DTF measurement, the tester uses frequency domain reflectometry. The transmitted and reflected signals contain information about the distance to the faults. This information is used to determine the physical distance to the faults. The tester displays the physical distance to the probable faults, corrected for cable loss and the velocity propagation factor of the cable.

Perform a DTF measurement

To make a DTF-return loss measurement over a frequency range of 50 to 400 MHz, perform the following steps:

- 1 Press the **MODE > Reflection Measurement > Distance To Fault** to select the DTF mode.
- 2 Press **FREQ > Start > 50 > MHz** to set the start frequency to 50 MHz.
- 3 Press **Stop > 400 > MHz** to set the stop frequency to 400 MHz.
- 4 Press **Calibrate** to bring up the calibration process guidance. Follow the instructions to perform a calibration. For more information about calibration, refer to “[Preparation](#)” on page 71.
- 5 Remove the calibrator and connect the cable under test (DUT) to the RF OUT connector on the top panel of the tester.

The DTF measurement starts and the results are displayed on the screen. A peak in the horizontal trace indicates a defective location.

Making a Power Measurement with USB Power Sensor

The N9322C spectrum analyzer supports the U2000 and U2020 series USB power sensors.

The U2000 Series USB power sensors do not need manual calibration and zero routines performed. Calibration and zeroing are performed without removing the power sensor from the source, through internal zeroing. With internal zeroing of U2000 Series USB power sensors, there is no need to disconnect the sensor or power-off the DUT. The U2000 Series do not require 50 MHz reference signal calibration, allowing the factory calibration to ensure measurement accuracy. For best accuracy, users are recommended to perform external zeroing for input signals below -30 dBm for best accuracy.

CAUTION

The maximum power for the RF IN port and the RF OUT port of the analyzer is +30 dBm (1 W). The maximum power for the U2000 Series Power Sensor port is +25 dBm (316 mW). When directly coupled to a base station, the test set can be damaged by excessive power applied to any of these three ports.

To prevent damage in most situations when directly connect an analyzer to a base station, use a high power attenuator between the analyzer and the BTS.

NOTE

If you suspect other signals may be present, it is recommended that you turn off all the other channels and measure average power only on the signal of interest. Another option is to measure channel power (which is less accurate), that filters out all other channels (signals).

Making an Average Power Measurement

The average power measurements provide a key metric in transmitter performance.

Base station transmit power must be set accurately to achieve optimal coverage in wireless networks. If the transmit power is set too high due to inaccurate power measurements, undesired interference can occur. If the transmit power is set too low, coverage gaps or holes may occur. Either case affects system capacity and may translate into decreased revenue for service providers. Average power can be measured for the channel of interest while the base station is active. All other channels should be inactive. Average power is a broadband measurement. If other signals are present the analyzer will also measure their power contributions.

Figure 3-25 Connection with base station

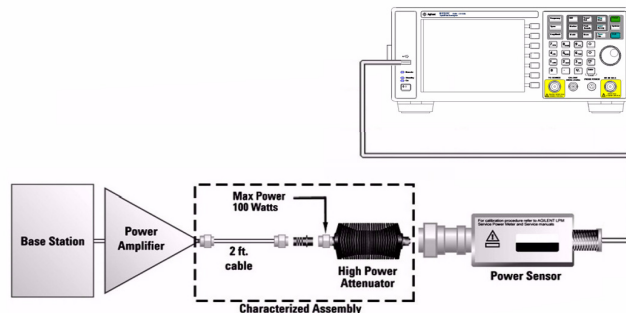

To make an average power measurement, you connect the power sensor and cable, zero and calibrate the meter, before making a measurement. Zeroing of the power meter will occur automatically:

- Every time you use the Power Meter.
- When a 5 degree C. change in temperature occurs.
- Whenever you change the power sensor.
- Every 24 hours.

- Before measuring low level signals—for example, 10 dB above the lowest specified power for your power sensor.

Calibrating the power meter every time you cycle the power on and off.

In most situations, you can press **Zero** to complete the two steps (zero and cal) together.

Follow the steps below to make a basic average power measurement.

- 1 Press **Preset**. (With **Preset Type** of **Factory**)
- 2 Press **Mode > Power Meter** to access the power meter mode.
- 3 Zero and calibrate the meter. Press **Zero** to make a Zero operation of the power sensor followed by a calibration operation.
- 4 Connect the power sensor to the USB port of N9322C. The analyzer will recognize the power sensor automatically.

CAUTION

To prevent damage to your sensor, do not exceed the power levels below.
U2000/1/2A +25 dBm (320 mW) average, 20 VDC
+33 dBm (2 W) peak, <10 μ s

For more information on the maximum power of U2000 series power sensors, please refer to the *Operating and Service Guide* of Agilent U2000 Series USB Power Sensors.

-
- 5 Connect the external attenuation, if required, with the power sensor used.
 - 6 Connect the analyzer to the base station. Connect the power sensor to the signal to be measured. A typical BTS connection is after the output of the power amplifier and duplexer. The connection requires a cable and two Type-N barrel connectors, in addition to the power sensor and external attenuator.

- 7 Press **Meas Setup > Disp Range** to set the display range of the measurement. when it is set to **On**, the display range will be adjusted automatically according to the signal power dynamic range. When it is set to **Off**, press **Top** and **Bottom** to set the display range manually.
- 8 Press **General Setup > Freq** to set the power frequency for the DUT. The current frequency will display in the bottom line.
- 9 Press **Power Range > Auto Power** to toggles the measurement range between **On** and **Off**. When it is set to **On**, the power range will be adjusted automatically. Use auto range when you are not sure of the power level you are about to measure. When it is set to **Off**, press **Range** to select the upper range or lower range. The lower range uses the more sensitive path and the upper range uses the attenuated path.

Table 1 Power Sensor Range

Sensor	Lower range	Upper range
U2000/1/2/4A	-60 dBm to -7 dBm	-7 dBm to +20 dBm
U2000/1/2H	-50 dBm to +3 dBm	+3 dBm to +30 dBm
U2000/1B	-30 dBm to +23 dBm	+23 dBm to +44 dBm

- 10 Press **Meas > Meas Seup > Disp Mode** to set the display in meter, chart or trace display. the measurement result will displays on the screen as shown.

Figure 3-26 Power Measurement

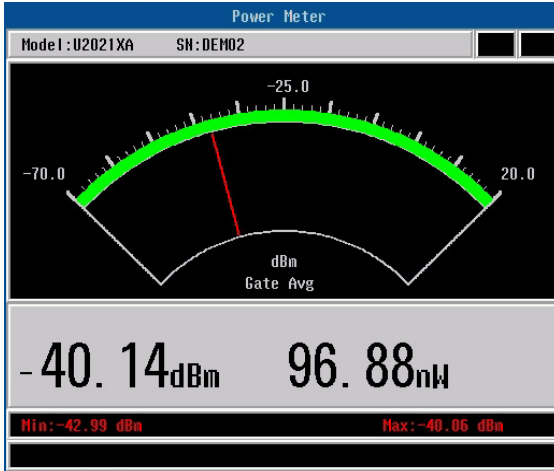

Making a Peak Power Measurement

The Agilent U2020 X-series USB peak and average power sensors enable peak power measurements that have the same accuracy as measurements obtained using traditional peak power meters, while providing the advantages of being a very compact and portable form factor.

Follow the steps below to make a peak power measurement.

- 1 Press **Mode > Power Meter** to access the power meter mode.
- 2 Connect the power sensor to the USB port of N9322C. The sensor will automatically initialize, perform zeroing (While remaining connected to the device under test), and calibrate without connecting to an external source.

NOTE

You can manually perform zeroing and calibration by pressing **Zeroing > Zeroing** and **Calibration** at any time after the sensor is connected and initialized.

- 3 Press **General Setup > Freq** to set the frequency of the signal under test.

As a wideband device, the power sensor has a frequency response. The power sensor utilizes a complex correction algorithm to remove power measurement error due to linearity error, frequency response, and temperature drift to generate a more accurate measurement.

The analyzer provide the customer preset function with U2020 X-series power sensor. Press **Meas > Preset** and the predefined protocol list will pop up. Select the wanted item and press **Preset** as a terminator. The related settings will be set automatically.

Figure 3-27 Customized Preset the U2020 Power Sensor

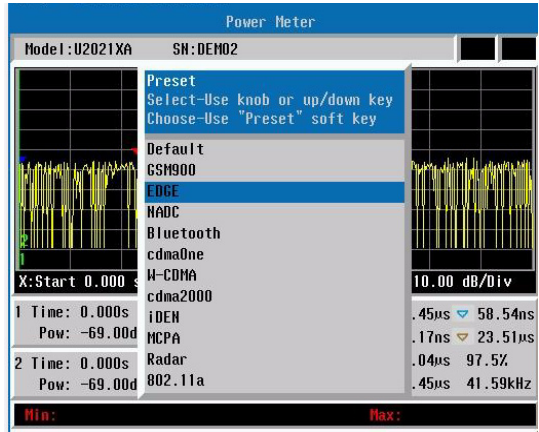

- 4 Press **Meas Disp > Disp Mode > Trace** to find the measurement results as [Figure 3-28](#) below.

Figure 3-28 Peak Power Measurement

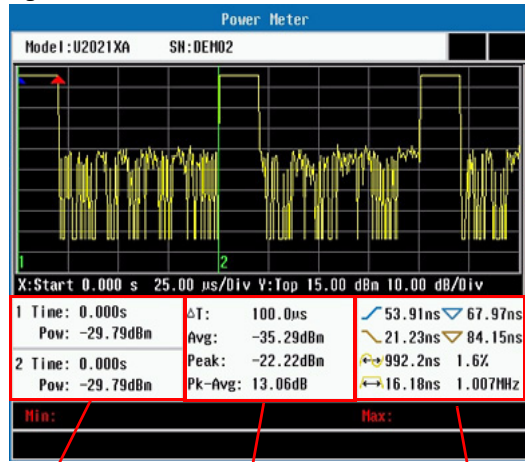

Marker Readings

Gate Results

Pulse Parameter Results

Power Meter Settings

Please find the sections below to find the general power meter measurement settings.

Setting the Power Meter Top and Bottom End-Points

Setting the end points (Disk Range) close to expected measurement value changes the sensitivity of the Power Meter scale resolution. This is an advantage in viewing small changes in power. However, this will not affect the overall range of the sensor. This is only available for Meter and Chart display mode. For Trace display, please press **Meas > Peak Setup > Trace Setup** to set the X and Y scale.

- 1 Press **Meas > Meas Disp > Dis Range** to access the end-points menu.
- 2 Press **Top** and enter the maximum scale value using the numeric keypad. Then press **dBm** to complete the setup.
- 3 Press **Bottom** and enter the minimum scale value desired using the numeric keypad. Then press **dBm** to complete the setup.

Setting Power Meter Resolution

There are four levels of power meter resolution. Higher resolutions provide more accuracy but slow the measurement speed. The resolution is only available for U2000 series power meter and free-run trigger mode in U2020 series power meter.

Press **Meas > Meas Disp > Resolution**. Select 1,2,3 or 4. The four options represent different resolution as follow:

- [1] = 1
- [2] = 0.1
- [3] = 0.01
- [4] = 0.001

Set the Step Detection

Press **Meas > General Setup > Average > Step Detect** to set the step Detect On and Off. When it is set to on, the filter will re-initialize upon detection of a step increase or decrease in the measured power to reduce the filter settling time after a significant step in the measured power, Step detection can be set in both manual and automatic filter modes.

Set the Measurement Gate

Press **Meas > Peak Setup > Gate Setup** to set the start time and gate length for a measurement gate. A measurement gate allows measurements to be performed on particular sections of the input signal. The gate is defined by a start time relative to the trigger instant and a duration. Signal samples acquired during the time interval specified by the gate are used for the measurements in that gate. A system of up to four independent gates is provided.

Set the Trigger

Press **Meas > Peak Setup > Trig/Acq** to set the trigger parameters listed below for the measurement gate.

Acqn Set the single, free run or continuous trigger mode. Select to enable trace and auto trigger delay for the single and continuous trigger modes. For the free run mode, only auto trigger delay can be enabled.

Source Set the trigger source to internal channel or an external source.

Mode Enable auto level or manually set the trigger level if the internal trigger source is selected.

Level sets the trigger level manually when the Mode is set to manual.

Delay Set the delay time to be applied between the trigger event and all the gate start times. This allows you to time-shift all the gates by the same amount with one setting change.

Slope Select the positive or negative slope type to determine if the trigger event is recognized on the rising or falling edge of a signal respectively.

Holdoff Set the holdoff time to disable the trigger mechanism after a trigger event occurs.

Hysteresis Set the hysteresis to help generate a more stable trigger by preventing triggering unless the RF power level achieves the trigger level and the additional hysteresis value. It can be applied to both rising and falling edge trigger generation.

Hysteresis is only available for the internal trigger source and manual trigger level.

Demodulate the AM/FM signal

The N9322C provide the AM/FM demodulation function.

Demodulating an AM Signal

The demodulation function allows you to demodulate and hear signal information displayed on the analyzer.

Simply place a marker on a signal of interest, set the analyzer in zero span, activate AM demodulation, turn the speaker on, and then listen.

- 1 Press **Preset**. (With **Preset Type** of **Factory**)
- 2 Connect an antenna to the RF IN connector.
- 3 Select a frequency range on the analyzer. For example, the frequency range for AM broadcasts in the United States is 550 to 1650 kHz:
Press **Frequency > Start Freq > 550 > kHz > Stop Freq > 1650 > kHz**.
- 4 Place a marker on the signal of interest:
Press **Peak Search > Next Right Pk** or **Next Left Pk**
- 5 Set the frequency of interest to center frequency:
Press **Marker > Marker To > Mkr -> Center**.
- 6 Change the resolution bandwidth to 100 kHz:
Press **BW > 100 > kHz**.
- 7 Press **Span > Zero Span**
- 8 Press **Sweep > Sweep Time > 10 s** to set the sweep time.
- 8 Set the detector type and turn on AM demodulation:
Press **Trace/Det > Detector > Sample**.
Press **Marker > Function > Demod**
Press **Demod Setting > Demod Type AM**

Demodulating an FM Signal

This section demonstrates how to demodulate and listen to an FM signal using the built-in FM demodulator.

Using the built in FM demodulator you can tune to an FM signal and view the results of the detector output as displayed in the time-domain.

- 1 Press **Preset**. (With **Preset Type** of **Factory**)
- 2 Use a signal source or connect an antenna to receive FM signal. In this example the signal is modulated at 300 MHz with FM deviation of 10 kHz and FM rate of 1 kHz.

NOTE

If you are using a broadcast FM signal, the FM channels are broadcasting between 87.7 MHz to 107.7 MHz.

- 3 Set the center frequency to the center of the FM signal (in this case 300 MHz):
Press **Frequency > 300 > MHz**.
- 4 Set the analyzer to zero span for time-domain analysis:
Press **Span > Zero Span**.
Press **Sweep > Sweep Time > 5 > s**.
- 5 Set the resolution bandwidth to capture the full bandwidth of the FM signal.
Press **BW > 100 > kHz**.
- 6 Turn on the optional pre-amplifier to detect small signals:
Press **Amplitude > Preamp On**.
- 7 Turn on the FM demodulator:
Press **Marker > Function > Demod**
Press **Demod Setting > Demod Type FM**

3 Functions and Measurements

Listen to the FM signal.

Press **Demod Setting > Speaker Vol**, rotate the knob to adjust the speaker volume.

The headphone jack is available for the audio signal output alternatively.

Analysis the Modulated Signals

The N9322C provides the optional AM/FM (Option AMA) and ASK/FSK (Option-DMA) modulation analysis function for analysis the modulated signals. These functions can be activated by license key.

AM/FM Modulation Analysis

Optional AM/FM demodulation analysis provides modulation metrics, including carrier power, modulation rate, AM depth/FM deviation, SINAD and carrier frequency offset. User definable limits provide Pass/Fail indicators of four types:

Maximum carrier power, Maximum AM modulation index or FM deviation, Minimum AM modulation index or FM deviation, and Minimum carrier frequency offset.

The user can save the waveforms with metrics for reporting as well as the set-up parameters for future measurements or analysis. In the following example, you can use any source available (such as AM/FM radio) as long as it has AM/FM signal generation capability.

AM Modulation Analysis

Please refer to the procedures below for the AM modulation analysis:

- 1 Connect the signal generator to RF IN connector and turn on the signal generator's AM and RF output.
- 2 Turn on the AM demodulation analysis function.
Press **MODE > Modulation Analysis > AM**.
- 3 Press **Frequency > Carrier Freq > 100 > MHz** to set the carrier frequency.
- 4 Set the attenuation state to Auto (default):
Press **Amplitude > Attenuation Auto**

- 5 Press **Shift > Disp > Y Scale > Scale Coupling On** to set the Y scale auto coupling.
- 6 Set the AM depth limit and turn on the limit function:
Press **Shift > Limit > AM Depth UP > 51 > % > AM Depth Low > 49 > % > Limits on**

The red value in the result indicates the demodulated AM depth exceeds the limits set as above.

Figure 3-29 AM demodulation analysis

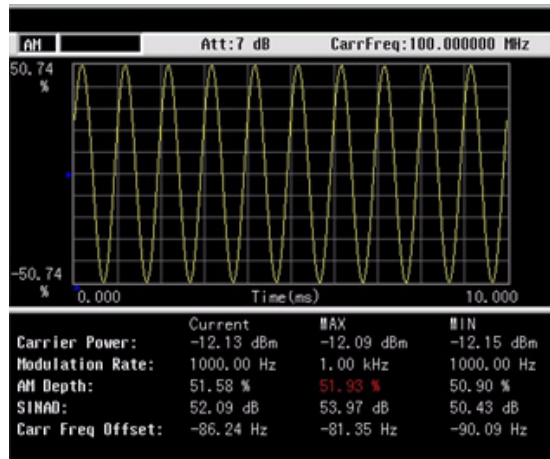

FM Modulation Analysis

Please refer to the procedures below for the FM modulation analysis:

- 1 Connect the signal generator to RF IN connector and turn on the signal generator's FM and RF output.
- 2 Turn on the FM demodulation analysis function.
Press **MODE > Modulation Analysis > AM**.
- 3 Press **Frequency > Carrier Freq > 100 > MHz** to set the carrier frequency.
- 4 Set the attenuation state to Auto (default):
Press **Amplitude > Attenuation Auto**

- 5 Press **Shift > Disp > Y Scale > Scale Coupling On** to set the Y scale auto coupling.
- 6 Set the FM deviation limit and turn on the limit function:
Press **Shift > Limits > FreqDev UP > 11 > % > FreqDev Low > 9.9 > % > Limits on**

The red value in the result indicates the demodulated FM deviation exceeds the limits set as above.

Figure 3-30 FM modulation analysis

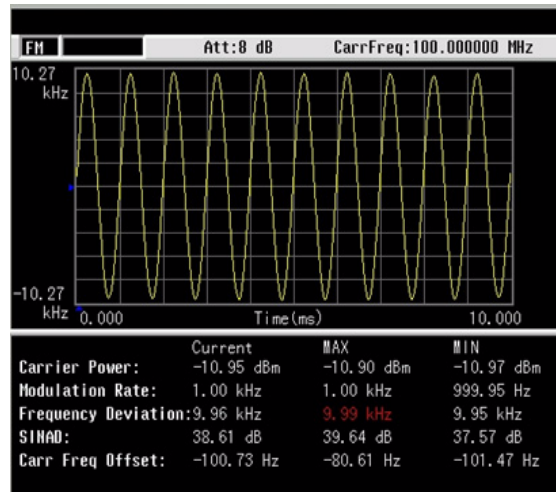

ASK/FSK Modulation Analysis

The ASK/FSK modulation analysis function supports four display modes:

- Symbol
- Waveform
- ASK/FSK Error
- Eye Diagram.

User definable limits provide Pass/Fail indicators of four types:

- Maximum carrier power
- Maximum ASK modulation depth/FSK frequency deviation
- Minimum ASK modulation depth/FSK frequency deviation
- Maximum carrier frequency offset.

The metrics includes carrier power, ASK/FSK error, ASK depth/FSK frequency deviation, and ASK index etc. The waveform with metrics and setup parameters can be saved for reports and future Measurements.

In the following example, you can use any source available (such as your remote key of the car) as long as it has ASK/FSK generation capability. For ASK/FSK signal, its Filter is Nyquist and Alpha is 0.35.

ASK Modulation Analysis

Please refer to the procedures below to analysis the ASK demodulation.

- 1 Connect the signal generator to RF IN connector and turn on the signal generator's ASK modulation and RF output.
- 2 Turn on the ASK demodulation analysis function.
Press **MODE > Modulation Analysis > ASK**.
- 3 Press **Frequency > Carrier Freq > 100 > MHz** to set the carrier frequency.
- 4 Press **Meas > Symbol Rate > 10 > MHz** to set the symbol rate.

- 5 Press **Filter Setup > Ref Filter > Nyquist** to set the filter type.
- 6 Set the attenuation state to Auto (default):
Press **Amplitude > Attenuation Auto**
- 7 Press **Shift > Disp > Y Scale > Scale Coupling On** to set the Y scale auto coupling.
- 8 Setting the ASK depth limit and turn on the limit function:
Press **Shift > Limits > ASK Depth UP > 71 > % > ASK Depth Low > 70 > % > Limits on**
- 9 Press **Shift > Disp > Display > Eye Diagram** to view the eye diagram.

Figure 3-31 ASK Eye Diagram

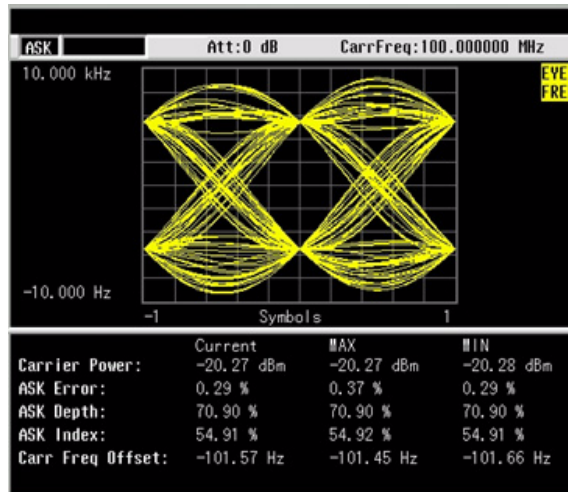

FSK Demodulation Analysis

Please refer to the procedures below to analysis the FSK demodulation.

- 1 Connect the signal generator to RF IN connector and turn on the signal generator's FSK modulation and RF output.
- 2 Turn on the ASK demodulation analysis function.
Press **MODE > Modulation Analysis > FSK**.
- 3 Press **Frequency > Carrier Freq > 100 > MHz** to set the carrier frequency.
- 4 Press **Meas > Symbol Rate > 10 > kbps** to set the symbol rate.
- 5 Press **Filter Setup > Ref Filter > Nyquist** to set the filter type.
- 6 Set the attenuation state to Auto (default):
Press **Amplitude > Attenuation Auto**
- 7 Setting the FSK deviation limit and turn on the limit:
Press **Shift > Limit > FreqDev UP > 85 > kHz > FreqDev Low > 80 > kHz > Limits on**

The figure below shows the FSK symbol and the measurement result.

Figure 3-32 FSK Symbol View

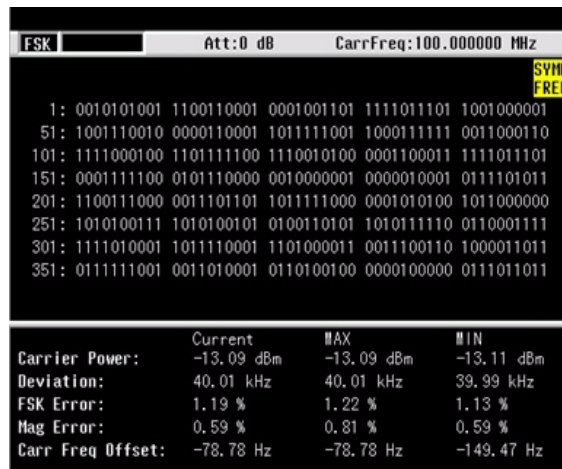

Measuring Channel Power

Channel Power measures the power and power spectral density in the specified channel bandwidth. A white frame on the display indicates the edge limits of the channel bandwidth. The user must specify the center frequency, reference level, and channel bandwidth to be used for the measurement.

The power calculation method used to determine the channel power is a traditional method known as the integration bandwidth (IBW) method. A swept spectrum is used as the basis for this calculation. Therefore, it is important to set the resolution bandwidth correctly before making this measurement using the following formula:

$$RBW = \frac{k(\text{span})}{n}$$

Please refer to the procedures below to set a channel power measurement.

- 1 Press **Meas > Channel Power** to select the channel power measurement mode
- 2 Press **Standard Customize** to choose the radio standard.
- 3 There are four wireless standard options: WCDMA, CDMA, LTE, GSM. Press **WCDMA** as an example.

Once the standard is set, the integration bandwidth and span will be automatically set according to the standard.

- 4 Press Center Freq to change the center frequency of the current signal channel. Adjust the center frequency to measure other channel power in the same standard.

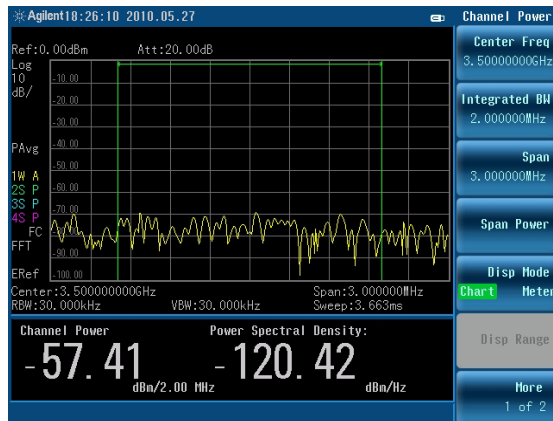

Please follow the similar procedure as above to measure the channel power in the CDMA and LTE standard.

To measure the channel power in GSM standard, the default setting is 10 MHz span, 300 kHz RBW, and the continuous peak search is enabled. The instrument will measure the channel power after the center frequency is changed.

Files Operation

The analyzer will store and retrieve data files similar to using a PC. The analyzer allows you to view and save files in the internal storage of the analyzer or to a USB storage device. This section provides information on how to locate catalogs (file types) and to save files.

Locating and Viewing Files in the Catalog

The analyzer has four types of files:

State	records the current controls and settings of the analyzer. Use this file type for saving test parameters for future recall, such as frequency and BW settings. (file extension: .STA).
Trace	stores trace information (file extension: .TRA).
Setup	records the system setting information, such as language, date/time, and power saving mode. This file type is not used for test parameter setup information. (file extension: .SET).
Screen	stores screen captures of the display (file extension: .JPG).
Limits	which stores data sets to determine whether a trace has exceeded preset specifications (file extension: .LIM)
CSV	records the trace data and available for review on PC. (file extension: .CSV)
Task Planner	contains the user-defined measurement tasks in sequence which make the test task easier in field test. (file extension: .TPF).
Correction	The amplitude correction file is used for trace amplitude offset compensation. Please refer to “Correction” on page 90 to edit and save the correction file on BSA PC software. (file extension: .TPF).
Standard	contains the frequency range and corresponding parameters for a specific communication standard. It allows you to recall those default settings for the signal searching and testing in that range. (file extension: .STD).

Saving a File

The analyzer allows you to save files (states, traces, limits or screens) to a USB storage device (**USB/**), or internal storage (**INT/**). The following is an example of how to save a trace to internal storage (**INT/**).

- 1 Select the save destination for the file. This example will select the internal storage (**INT/**):
Press **File > Directory > Memory Type INT**
- 2 Press **Return > Save as**, the pop-up window displays for your further setting.
- 3 Edit a file name.
A file name can consist of letters and digits. A single key stroke on the numerical keypad inputs a digital number; and consecutive key stroke selects and inputs a letter.
- 4 Rotate the knob to choose the file type you need.
- 5 Press **Enter** to save the file. The file will be saved immediately and “File saved” will be shown in the status bar.

CAUTION

When saving a file to a USB storage device, do not disconnect the USB device during the save operation. To do so may cause unexpected data loss.

Quick Saving a File

Press [**Save**] to quickly save a trace or a screen to either the local memory or an external USB device, depending upon the setup of the save path.

Refer to the steps for saving a trace/screen:

- 1 Press **File > Setup > Qsave Type** to set the quick save file type.
- 2 Press **File > Directory > Media Type** to select the file directory.
- 3 Press **Return > Save** to save a trace or a screen copy to the pre-defined memory. The trace or screen will be automatically assigned with a default file name. A trace will be assigned with a file name, such as *HYTRACE*,

HYTRACE_1, and consecutive decimal numbers appended to the alphabetic file name, such as *HYSSCREEN*, *HYSSCREEN_1* and consecutive decimal numbers appended to the alphabetic file name.

Saving a User State

The analyzer allows you to recall the frequently used state file with **User** hardkey. Please follow the steps below to create the user menu.

- 1** Follow the file saving procedure above to save a state file in internal memory.
- 2** Rotate the knob to highlight the saved file.
- 3** Press **Files Operation > Copy to**
- 4** Rotate the knob to highlight the folder named *USER*. Press **Browse Folder** to access into this folder.
- 5** Rotate the knob to highlight the folder named *State*. Press **Browse Folder** to access into this folder.
- 6** Press **Copy** to copy the file into the *User/State* folder.

The state file is available for your quick recall by pressing **User**.

Loading a File

This feature will recall (load) onto the displayed screen a previously saved filename and type compatible with this analyzer. The file types are described above.

- 1 Press **File > Directory > {Memory Type}** to select a directory.
- 2 Rotate the knob to highlight a file.
- 3 Press **Recall** to recall this file.

The wanted file will be loaded immediately.

Loading a Task Planner File

Please refer to the following procedures to load a task planner file.

- 1 Press **Mode > Task Planner** or **File > View FileType > TPF** to view the task planner file list.
- 2 Rotate the knob to highlight the task planner file which you need.
- 3 Press **Recall** to load the task planner file. The measurement task will list in sequence.
- 4 Press **Run** to initiate the measurement in sequence.

NOTE

The task planner file is created by the BSA PC software. For the task planner saving and editing, please refer to the software online help for details.

For the automatic task, all the measurement tasks are executed automatically without interruption. For the manual task, the program is paused and releases a result report when each measurement is finished. The program will be continued once you input the next instruction.

For the manual-if-failed task, the measurement tasks are executed continuously unless there is a failed result.

Copying a File

To copy a file from internal storage to a USB storage device, follow this procedure:

- 1 Connect a USB storage device to the USB connector.
- 2 Press **File > Directory > Memory Type** to select the path to **INT**.
- 3 Select the type of file. Assume you need to copy a trace file:
Press **Return > View FileType > Trace**
- 4 Using the knob or arrow keys to highlight the file name you need.
- 5 Press **File Operation > Copy To** to access the copy submenu. Chose the location for copy destination, then press **Copy** to copy the file immediately.

Deleting a File

Perform the following process to delete a specific file. Note that once a file is deleted from local memory, it cannot be recovered.

- 1 Press **File > Directory > Memory Type** to select the path
- 2 Using the knob or arrow keys to highlight the file name you want to load.
- 5 Press **File Operation > Delete**. Press **Enter** as a terminator and the file will be deleted immediately.

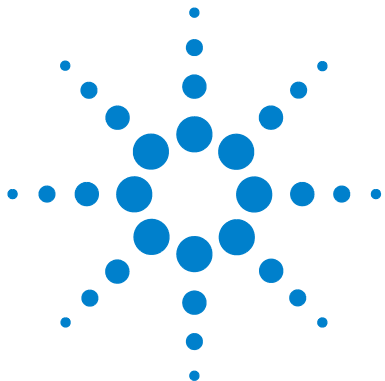

4 Key Reference

This chapter describes each front panel hardkey and their associated softkeys (menus). The front panel key descriptions are organized alphabetically. The lower level softkeys are listed as they appear in the softkey menus.



Amplitude

Press **Amplitude** hardkey to activate the reference level function and access the amplitude softkey menu. The softkey menu selections are described as follows:

- Ref Level** Sets the reference level. This function is activated when **Amplitude** is pressed. The reference level is the amplitude power or voltage represented by the top line of the graticule on the display. Setting the reference level changes the absolute amplitude level (in the selected amplitude units) of the top graticule line.
Key access: **Amplitude > Ref level**
- Attenuation**
Auto Man Toggles the input attenuation between **Auto** and **Man**. The attenuation level can be set in as little as 1 dB increments when **Man** is selected. The analyzer input attenuator is normally coupled to the reference level control, it reduces the power level of the input signal at the input mixer. Selecting **Auto** re-couples the attenuator. Change the attenuation by using the arrow keys, the knob, or the numeric keypad.
Key access: **Amplitude > Attenuation**
- Preamp**
On Off (Option P07) Toggles the internal pre-amplifier function between on and off. Pressing **Preamp (On)** results in a correction being applied to compensate for the gain of the preamp. Amplitude readings then represent the signal value at the input connector. When the preamp is on, a “PA” indication appears on the left side of the display. The preamp operates over a range of 100 kHz to 7 GHz.
Key access: **Amplitude > Preamp**
- Scale/Div** Sets the logarithmic units per vertical graticule division on the display. The valid logarithmic units are 1, 2, 5 and 10 dB per division. The **Scale/Div** function is available only when the **Scale Type** key is set to **Log**.
Key access: **Amplitude > Scale/Div**

- Scale Type** Scales the vertical graticule divisions in logarithmic units when **Log** is selected. The valid logarithmic units are 1, 2, 5 and 10 dB per division. When **Lin** is underlined, the vertical divisions are linearly scaled with default amplitude units of volts. The top of the graticule represents the reference-level value; the bottom of the graticule represents zero volts. (Each division is one-tenth of the reference level.)
- Key access: **Ampiltude > Scale Type**
- Y Axis Unit** Accesses the softkeys that change the amplitude units (logarithmic or linear). Change the amplitude units by pressing **dBm**, **dBmV**, **dBuV**, **dBuA**, **Watts**, **Volts**, and **Amps**.
- Key access: **Ampiltude > Y Axis Unit**
- Hi-Sensitivity** Set this softkey to **On** to set 0 dB attenuation, -50 dBm reference level and turn the preamplifier on. It's very helpful to observe the low-level signals with this settings.
- Key access: **Ampiltude > More > Hi-Sensitivity**
- Ref Offset** Adds an offset value which ranges from -327.6 dB to +327.6 dB, to the displayed reference level. Reference-level offsets are only entered by using the numeric keypad. Entering an offset does not affect the trace or the attenuation value. Reference-level offsets are used when gain or loss occurs between a device under test and the analyzer input. Thus, the signal level measured by the analyzer may be referred to as the level at the input of an external amplitude-conversion device. When an amplitude offset is entered, its value appears on the left side of the display under **Offst** (as opposed to frequency offsets which appear at the bottom of the display). To eliminate an offset, press **Ref Offset > 0 > dB**.
- Key access: **Ampiltude > More > Rel Offset**

Corrections Accesses the corrections submenu to enable the corrections function for amplitude compensation. The amplitude correction is used to compensate the gain/attenuation from antenna/cable. Please refer to the procedures below to use the amplitude correction function.

- 1 Please refer to the procedures below to create a correction file in BSA PC software.
 - a Open the PC software.
 - b Press **File > New > Correction** to access the correction file editing pop-up menu.
 - c Refer to to add the point data with frequency and amplitude offset value.

Figure 4-1 Editing correction file in PC software

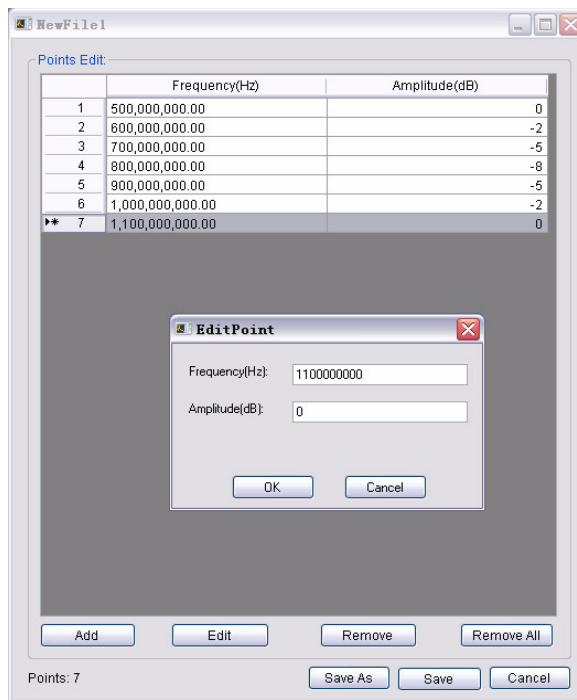

- d When the editing is completed, press **Save/Save As** to save the correction file.

- 2 Set a folder named N932xDATA in a USB disk and put the saved correction file in. Insert the USB disk on top panel for further loading.
- 3 Press **Amplitude > More > Corrections** to access the correction function.
- 4 Press **Cable/Antenna/Other/User** to select the correction type.
- 5 Press Recall to load this correction file. The correction file name will be shown on the Correction1 softkey and the **Apply Corrections** is set to On automatically which indicates the amplitude compensation has been applied to the displayed trace.

Press **Apply Corrections off** to turn off all the corrections.

Set **Antenna Unit** to **On** to switch to graticule unit from dBm to dBmV/m for field strength measurement.

Key access: **Amplitude > More > Correction**

**Impedance
50ohm 75ohm**

Toggles the computational input impedance between 50ohm and 75ohm. This is only software function in which sets the input impedance for unit conversions. This set affects the results when the y axis unit is voltage or current units (dBmV, dB μ V, dB μ A, V, A) but does not affect the results when it is power units (dBm, W). The selected impedance is for computational purposes only, since the actual impedance is set by internal hardware to 50 ohm.

Key access: **Amplitude > More > Impedance**

**PSD Function
On Off**

Press this softkey to turn on the power spectral density function. When it is set to On, the measurement result and amplitude parameters will be shown in power spectral density. The PSD function can only be enabled in Spectrum Analysis and Spectrum Monitor mode.

Key access: **Amplitude > More > PSD Function**

BW

This hardkey activates the resolution bandwidth function and accesses the softkey menus that control the bandwidth and averaging functions.

**Res BW
Auto Man** controls the 3 dB resolution bandwidth of the analyzer from 10 Hz to 3 MHz using the knob or arrow keys. There are four available bandwidths less than 1 KHz are 10, 30, 100 Hz or 300 Hz. If an invalid bandwidth is entered using the numeric keypad, the analyzer chooses the closest acceptable bandwidth. As the resolution bandwidth is decreased, the sweep time is modified in order to maintain amplitude accuracy. Resolution bandwidth is also coordinated with the frequency span. As the span is decreased, the resolution bandwidth decreases. When the VBW/RBW is set to **AUTO**, if the resolution bandwidth changes, the video bandwidth changes to maintain the VBW/RBW ratio.

A “#” mark appears next to “Res BW” on the display when it is not coupled. To recouple the resolution bandwidth, press **Res BW (Auto)**.

Key access: **BW > RBW**

**Video BW
Auto Man** changes the analyzer post-detection filter from 1 Hz to 3 MHz using the knob or arrow keys. If an invalid bandwidth is entered, the analyzer chooses the closest available bandwidth. As the video bandwidth decreases, the sweep time will increase to maintain amplitude accuracy.

A “#” mark appears next to “VBW” on the bottom of the analyzer display when it is not coupled. To couple the video bandwidth, press **Video BW (Auto)**.

Key access: **BW > VBW**

**VBW/RBW
Auto Man** Sets the ratio between the video and resolution bandwidths. When a signal is weak and is visually masked by the noise floor, set the ratio to less than 1 to lower the noise. When the **Preset Type** is set to **Factory** and **Preset** is pressed, the ratio is set to 1. Change the ratio by using the arrow keys,

knob, or numeric keypad. When **VBW/RBW (Auto)** is selected, the ratio is determined automatically by the rules in Figure 4-1.

Figure 4-1 VBW/RBW Ratio Auto Rules

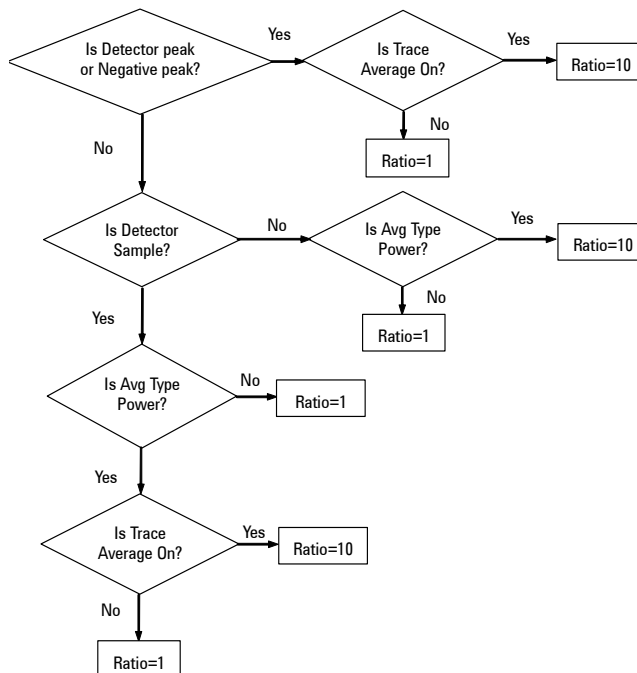

Key access: **BW > VBW/RBW**

Average Type

Chooses one of the following averaging scales: log power (video), power (RMS), or voltage averaging. When trace average is on, the average type is shown on the left side of the display. Selecting an average type manually causes the analyzer to use that type without regard to other analyzer settings.

Key access: **BW > Average Type**

- Voltage** Selects the logarithmic (decibel) scale for all filtering and averaging processes. This scale is “Video” because it is the most common display and analysis scale for the video signal within a spectrum analyzer. This scale is excellent for finding CW signals near noise. When this type of averaging is selected, `LgAv` appears on the left side of the display.
- Power** In this average type, all filtering and averaging processes work on the power (the square of the magnitude) of the signal, instead of its log or envelope voltage. This scale is best for measuring the true time power of complex signals. When this type of averaging is selected, `PAvg` appears on the left side of the display.
- Log Pwr** In this Average type, all filtering and averaging processes work on the voltage of the envelope of the signal. This scale is good for observing rise and fall behavior of AM or pulse-modulated signals such as radar and TDMA transmitters. When this type of averaging is selected, `VAvg` appears on the left side of the display.

There are actually four types of averaging processes within a N9322C. All, except VBW filtering, are affected by this setting. They are listed as follows:

- **Trace averaging**

Averages signal amplitudes on a trace-to-trace basis. (Press **Log Pwr** or **Pwr**)

- **Average detector**

Averages signal amplitudes during the time or frequency interval and represents the result as a single measurement point.

- **Noise marker**

Averages signal amplitudes across measurement points to reduce variations for noisy signals.

- **VBW filtering**

Performs a form of averaging of video signal.

Display

Press **Shift > Disp** to control detector and display functions.

Graticule Press this softkey to turn on the graticule display for the trace.

Key access: **Shift > Disp**

Y Scale Press this softkey to turn on the amplitude scale unit display on the left of the graticule. The unit is determined by the **Y Axis Unit** softkey.

Key access: **Shift > Disp**

Display Line Activates an adjustable horizontal line that is used as a visual reference line.
The display line, used for trace arithmetic, has amplitude values that correspond to its vertical position when compared to the reference level. The value of the display line appears in both the active function block and on the softkey. The arrow keys, knob, or numeric keypad may be used to adjust the display line. Pressing any digit, 0 through 9, on the numeric keypad brings up the selected terminator menu. To deactivate the limit line, press **Display Line (Off)**

Enter

Terminates a front-panel keypad numeric entry and enters that value into the analyzer. (For most applications, it is better to use the units softkeys to terminate value entry.) When in **File** menu, the **Enter** key is used to terminate filename entries.

When the analyzer is in the remote mode, pressing **Enter** returns the analyzer to the local control mode and enables front-panel inputs.

ESC <-

This hardkey provides mainly two types of functions:

Clear

- Clears any numeric entry and cancels the active function.
- Clears any title entry and cause the title to revert to the previous name.
- Clears input or output overloads
- Clears error messages from the status line along the bottom of the display.

Association with other functions

Provides a permitted setting for triggering other functions such as:

- Activates **LIMIT** function for pass/fail judgements.
- Activates **SAVE** function for current trace saving.

CAUTION

When pressing [**ESC<-**], the current parameter annotation in the lower left corner, which is an indicator of available settings of **Limit** and **Save**, disappears.

Frequency

The hardkey activate the center frequency function, and access the menu softkeys for frequency functions. The center frequency, or start and stop frequency values appear below the graticule on the display.

NOTE

When changing both the center frequency and span, change the frequency first. The frequency value may limit the span.

Auto Tune

performs the following functions automatically:

- 1 Run **Peak Search** in full span
- 2 Run **Mkr -> CF**
- 3 Select the appropriate reference level according to the amplitude of searching signal.
- 4 Set span to 1 MHz and all auto couple to view the signal.

NOTE

The Auto Tune functions in the frequency range of 5 MHz to 7 GHz. The minimum detectable amplitude is -65 dBm.

For more information about **Peak Search**, refer to “[Peak Search](#)” on page 148.

Key access: **Frequency > Auto Tune**

Center Freq

activates the center frequency function and sets the horizontal center of the display to a specific frequency.

Key access: **Frequency > Center Freq**

Start Freq

sets the frequency starting at the left side of the graticule. The left and right sides of the graticule correspond to the start and stop frequencies.

Key access: **Frequency > Start Freq**

Stop Freq

sets the frequency at the right side of the graticule. The left and right sides of the graticule correspond to the start and stop frequencies.

Key access: **Frequency > Stop Freq**

CF Step changes the step size for the center frequency function. On selecting a step size and activating the center frequency function, the arrow keys change center the frequency by the step-size value. The step size function is useful for finding harmonics and sidebands beyond the current frequency span of the analyzer. Selecting auto-couple sets the center frequency step size to one division (10 percent of the span).
Auto Man Key access: **Frequency > CF Step**

Channel Std. The Channel Standard softkey is a shortcut to load a factory-preset standard file (*.STD) which is located in system memory as default. The standard file list includes most communication protocol standards which is used in several countries. Please refer to "Loading a file" on page 72 for how to recall a file.
Key access: **Frequency > Channel Std.**

Freq Offset inputs a frequency offset value added to the frequency readout of the marker, to account for frequency co versions external to the analyzer. Offset entries are added to all frequency readouts including marker, start frequency, and stop frequency. Offsets may only be entered using the numeric keypad. Offsets are not added to the span or frequency count readouts. Entering an offset does not affect the trace display. When a frequency offset is entered, its value appears on the bottom of the display. To eliminate an offset, perform a **Factory Preset**, or press **Freq Offset, 0, Hz**.
When a frequency offset is entered, its value appears on the bottom of the display (as opposed to reference level offsets, which appear on the left side of the display). To eliminate an offset, press **Freq Offset, 0**, and **Enter**. Pressing **Preset** also sets the offset to zero.
Key access: **Frequency > CF Step**

**Low Frequency
Channel**

This softkey toggles the baseband channel on and off. When it is set to On, the SSB and DANL performance will be better from 3 kHz to 12 MHz. This softkey is only visible when the option BB1 has been installed and only available in Spectrum Analysis, Spectrum Monitor mode.

Key access: **Frequency > CF Step**

Marker

This hardkey accesses the marker control softkeys to select the type and number of markers. Markers are diamond-shaped characters that identify points of traces. Up to six pairs of markers may appear on the display simultaneously; only one pair can be controlled at a time. The marker that is controlled is called the “active” marker. Pressing **MARKER** activates the Normal menu key.

Marker Selects one of the twelve possible markers. If a marker has already been selected it will become the active marker.
Key access: **Marker > Slect Marke**

Marker Trace Places a marker on the selected trace, if no markers have been previously turned on. If a marker is currently active, press **Marker Trace** until **1**, **2**, **3**, or **4** is underlined: the active marker moves to the selected trace.

Auto 1 2 3 4

Selecting **Auto** mode moves the marker to the automatically selected trace. The trace selection will search for the lowest numbered trace in the following mode order: **Clear-write**, **Max-hold**, **Min-hold** and **View**. If there are no traces in any of these modes, it selects trace **1**.

Key access: **Marker > Marker Trace**

Mode Normal Activates a single frequency marker at the center of the active trace if not already displayed.

Displaying a marker before enabling the **Normal** function enables the marker at the position of the selected marker. The marker number shows above the marker. The knob and/or arrow keys move the marker left or right. Entering a value from the numeric keypad moves the marker to the trace point nearest to that value. Annotation in the active function block and in the upper-right corner indicates the frequency and amplitude of the marker (time and amplitude, if in zero span.) Pressing **Normal** turns off the **Delta** function and moves the active marker to the delta marker position.

Key access: **Marker > Mode > Normal**

Delta activates a second marker at the position of the first marker. If no marker is present, two markers with the same identification number will appear at the center of the display. The marker number is indicated above the delta marker, and the same number is indicated with an R (for example, 1R) above the reference marker. The amplitude and frequency (or time) of the first marker is fixed. Use the data control keys to position the delta marker. Annotation in the active function block and in the upper-right corner indicates the differences between the two markers, frequency/time and amplitude.

Key access: **Marker > Mode > Delta**

Delta Pair Toggles the **Delta Pair** between the reference (start) and delta (stop) markers. The start marker number is indicated with a number and an R (reference) above the marker (for example, 1R). The delta marker is identified with the marker number only.

Key access: **Marker > Mode > Delta Pair**

Span Pair Toggles the **Span Pair** function between the span and center markers. The start marker number is indicated with a number and an R above the marker (such as 1R) and the stop marker is indicated with only the marker number. Adjusting the span changes the frequency difference between the two markers while maintaining the midpoint at a fixed frequency. Selecting **Center** changes the center point between the two markers while maintaining the frequency difference.

Key access: **Marker > Mode > Span Pair**

NOTE

Ref and Delta markers maintain their displayed x-axis location. But, the frequency values will change if the frequency or span parameters define the x-axis scale are changed. Reset these markers, if necessary, when parameters such as span or center freq are changed.

Off Turns off the active function markers.
Key access: **Marker > Mode > Off**

Marker To Accesses the following marker function menu keys:

To Center Sets the center frequency of the analyzer to the marker frequency. In Delta mode, this softkey sets the center frequency to the marker delta value. The function is not available in zero span.

To Start Changes the start frequency so that it is equal to the frequency of the active marker. In Delta mode, this softkey sets the start frequency to the marker delta value. To Start is not available in zero span.

To Stop Changes the stop frequency so that it is equal to the frequency of the active marker. In Delta mode, this softkey sets the stop frequency to the marker delta value. To Stop is not available in zero span.

To Reference Changes the reference level to the active marker value, moving the marked point to the reference level (top line of the graticule). In Delta mode, this softkey sets the reference level to the amplitude difference between the markers.

Key access: **Marker > Marker To**

Function Accesses the marker function softkeys listed below.

Normal Activates the default readout mode. This function is set to default marker function.

Counter Activates a frequency counter mode.

Noise Activates a noise readout mode for evaluating power density.

Band Power Indicates the power over that part of the trace between the reference and active markers.

Demod Activates the demodulation mode.

Demod Setting Accesses the menu keys to select AM demodulation, FM demodulation or demodulation Off. It also accesses the Speaker Vol, and Delay Time menu keys described below.

Key access: **Marker > Function**

- Marker Table** Compresses the graticule and displays marker information in a table. The information includes the marker number, trace number, marker type, X axis value, and the amplitude.
Key access: **Marker > Marker Table**
- Read Out** Accesses the following menu keys that allow you to change the active marker readout. This function is only available in non-zero span.
- Frequency** Sets the marker to Frequency. The default selection in non-zero spans, displays the absolute frequency of a normal marker or the frequency of the delta marker relative to the reference marker.
- Period** Sets the marker readout to Period. Displays the reciprocal of the above frequency.
- Time** Sets the marker readout to Time. The default selection in zero span, displays the time interval between a normal marker and the start of the sweep or the time of the delta marker relative to the reference marker.
- Key access: **Marker > More > Read Out**
- Zoom In/Out** Activates the marker zoom in/out function which triggers a series of operation as below:
- Save current state as a backup state file.
 - Set center frequency as current marker frequency value.
 - narrow the span to 1/10 as previous span.
 - If RBW is set to Auto, the RBW will be coupled with span automatically. If RBW is set to manual, the RBW will be narrowed as 1/10.
- Zoom out resumes the state before Zoom in is pressed.
- Key access: **Marker > More > Read Out**
- Delta Ref** Adjusts the delta marker reference level manually. This function is exclusive when marker mode is set to delta.

Key access: **Marker > More > Delta Ref**

All Off Turns off all markers, including markers used for signal track, and marker annotations.

Key access: **Marker > More > All Off**

Logging Start/Stop Press this softkey to start recording the marker value to a CSV file. The frequency and amplitude value of the marker will be continuously recorded in the file.

Press this softkey (Logging Stop) again to stop logging and save the CSV file immediately.

Key access: **Marker > More > Read Out**

Meas

In the **Spectrum Analyzer** mode (see **MODE**), **Meas** key displays a menu for measurements such as adjacent channel power, occupied bandwidth, channel power, spectrum emission mask and TOI. Press **Measure Off** to turn the measurement off.

Channel Power

Channel Power measures the power and power spectral density in the specified channel bandwidth. A white frame on the display indicates the edge limits of the channel bandwidth. The user must specify the center frequency, reference level, and channel bandwidth to be used for the measurement.

- Center Freq** Sets the center frequency of display.
Key access: **Meas > Channel Power**
- Integ BW** Specifies the range of integration used in calculating the power in a channel. For example, set the main (center) channel bandwidth. Note that the white frame indicates the integration bandwidth. Be sure the span is set between 1 and 10 times the integration bandwidth. Change integration bandwidth by using the knob and the arrow keys.
Key access: **Meas > Channel Power**
- Span** Sets the sweep span of display.
Key access: **Meas > Channel Power**
- Span Power** Set the integrated bandwidth to the sweep span of display. The channel power and power spectral density display on the screen simultaneously.
Key access: **Meas > Channel Power**

- Disp Mode** This softkey toggles the display mode between **chart** and **Meter**.
Key access: **Meas > Channel Power**
- Disp Mode** This softkey is only available when the display mode is set to Meter. Pressing **Auto Range** toggles the display mode between **On** and **Off**. When Auto Range is set to **off** (manual), press **Top** and **Bottom** to set the display range of the channel power meter.
Key access: **Meas > Channel Power**
- RRC Filter** This softkey is a combined key to set the Root-Raised Cosine filter state and the filter Alpha value. When the filter is set to On, there will be an annotation “RRC ON” on the display.
Key access: **Meas > Channel Power**
- Filter BW** Press this softkey to set the filter bandwidth of the RRC filter. The default value is 2 MHz.
Key access: **Meas > Channel Power**

Occupied BW

Occupied Bandwidth integrates the power of the displayed spectrum. The power-bandwidth routine first computes all signal power contained in the trace, then calculates the span containing the power of the specified percentage. The percentage value default is 99% of the occupied bandwidth power.

For 99% occupied power bandwidth, Markers are placed at the frequencies on either side of 99% of the power. 1% of the power is evenly distributed outside the markers. The difference between the marker frequencies is the 99% power bandwidth.

This is the main menu of occupied bandwidth measurement including all related parameters and measurement results.

The occupied bandwidth function also indicates the difference between the center frequency and the center frequency of the channel. This “Transmit Freq Error” is defined as the difference between the $(f_1 + f_2)/2$ and the tuned center frequency of the signal.

NOTE

To get the correct measurement result, first set the center frequency, reference level, and channel spacing.

- Selecting a Method

Press **MEAS > OBW > Method** to toggle the occupied bandwidth measurement mode between **percentage (%)** and **dBc**.

- Setting Percentage (%)

Press **{OBW > Method > Percent** to edit the percentage of signal power used when determining the occupied bandwidth. Press **{%}** to set the percentage ranging from 10.00% to 99.99%.

- Setting dBc

Press **{OBW}** > **{Method}** > **{dBc}** to specify the power level used to determine the emission bandwidth as the number of dB down from the highest signal peak, within the occupied bandwidth span. This function is an independent calculation from the OBW calculation. The x dB bandwidth result is also called the emissions bandwidth (EBW). This sets the green frame (f1 and f2 are the two cross points of the signal and the pair of vertical lines of the displayed green frame) to your specified dB value below the maximum power, and compute the total power in the frame. The emission bandwidth is then calculated ranging from 0.1 dB to 100 dB (the default value is set to 26 dB).

ACPR

Adjacent Channel Power Ratio (ACPR) measures the power present in adjacent transmit channels. The span is automatically set according to the six available offsets and their associated integration bandwidths as defined by the user.

- | | |
|----------------------------|---|
| Center Freq | Sets the center frequency of the main channel power.
Key access: Meas > ACP |
| Main Channel | Specifies the range of integration used in calculating the power in the main channel. Use the knob, the arrow keys, or the numeric keypad to set the bandwidth.
Key access: Meas > ACP |
| Adjacent Chn State | Press Adjacent Chn to choose the number of the adjacent channel. There are optional 6 adjacent channels. Press adjacent Chn State to turn on/off each adjacent channel power display.
Key access: Meas > ACP |
| Adjacent Channel BW | Specifies the range of integration used in calculating the power in the adjacent channel. Use the knob, the arrow keys, or the numeric keypad to set the bandwidth.
Key access: Meas > ACP |
| Adj Chn Space | Sets the space value between the center frequency of main channel power and that of the adjacent channel power.
Key access: Meas > ACP |
| RRC Filter | This softkey is a combined key to set the Root-Raised Cosine filter state and the filter Alpha value. When the filter is set to On, there will be an annotation "RRC ON" on the display.
Key access: Meas > ACP |
| Filter BW | Press this softkey to set the filter bandwidth of the RRC filter. The default value is the integrated bandwidth.
Key access: Meas > ACP |

Spectrum Emission Mask

Spectrum Emission Mask measurement includes the in-band and out-of-band spurious emissions. As it applies to W-CDMA (3GPP), this is the power contained in a specified frequency bandwidth at certain offsets relative to the total carrier power. It may also be expressed as a ratio of power spectral densities between the carrier and the specified offset frequency band. For WLAN, the reference power is taken as the peak PSD in the signal, and all offset results are also the peak PSD in that offset as opposed to the integrated power.

Avg Number On Off	Set Avg Number to On to specify the number of measurement averages used when calculating the measurement result. The average will be displayed at the end of each sweep. Setting Avg Number to Off disables measurement averaging. Key access: Meas > SEM
Meas Type	Displays a menu to select a measurement reference type, Total Pwr Ref or PSD Ref . Key access: Meas > SEM
Total Pwr Ref	When Total Pwr Ref is selected, the power in the carrier is used as the reference in computing the relative power values for the offsets.
PSD Ref	When PSD Ref is selected, the mean power spectral density of the carrier is used in computing the relative power spectral density values for the offsets.
Ref Channel	Accesses the softkeys to change the reference channel settings. Key access: Meas > SEM
Chan Integ BW	Specifies the integration bandwidth used in calculating the power in the main channel.
Chan Span	Specifies the span used in measuring the power in the main channel.

Sweep Time Auto Man	Specifies the sweep time used in measuring the power in the main channel.
Res BW Auto Man	Specifies the resolution bandwidth used in measuring and the power in the main channel.
Total Pwr Ref (PSD Ref) Auto Man	<p>Displays the type of power measurement reference selected by Measure Type.</p> <p>Total Pwr Ref is the power in the carrier that is used as the reference in computing the relative power values for the offsets. When Man is selected, this can be set by the user. When Auto is selected, this is the measured power in the reference carrier.</p> <p>PSD Ref is the mean power spectral density in the carrier that is used as the reference in computing the relative power spectral density values for the offsets. When Man is selected, this can be set by the user. When Auto is selected, this is the measured mean power spectral density in the reference carrier.</p> <p>Key access: Meas > Spectrum Emission Mask > Ref Channel</p>

Offset/Limits Displays the menus to change the following parameters for offset frequency settings and pass/fail tests: **Offset, Start Freq, Stop Freq, Sweep Time, Res BW, and Limits**. Refer to the tables below for default settings of particular radio standards of interest.

Key access: **Meas > Spectrum Emission Mask**

4 Key Reference

Table 4-1 Offsets & Limits Defaulted for W-CDMA (3GPP) Base Station Measurements^a

Offset	Start Freq (MHz)	Stop Freq (MHz)	Res BW (kHz)	Abs Start (dBm)	Abs Stop (dBm)	Abs Couple	Rel Start (dBc)	Rel Stop (dBc)	Meas BW
A. On	2.515	2.715	30.00	-14.00	-14.00	Couple	-30.00	-30.00	1
B. On	2.715	3.515	30.00	-14.00	-26.00	Man	-30.00	-30.00	1
C. On	3.515	4.000	30.00	-26.00	-26.00	Couple	-30.00	-30.00	1
D. On	4.000	8.000	1000.00 30.00	-13.00	-13.00	Couple	-30.00	-30.00	1 33
E. On	8.000	12.500	1000.00	-13.00	-13.00	Couple	-30.00	-30.00	1

a. **Fail Mask** is set to **Absolute** and **Rel Stop** is set to **Couple**.

Table 4-2 Offsets & Limits Defaulted for W-CDMA (3GPP) Mobile Station Measurements^a

Offset	Start Freq (MHz)	Stop Freq (MHz)	Res BW (kHz)	Abs Start (dBm)	Abs Stop (dBm)	Rel Couple	Rel Start (dBc)	Rel Stop (dBc)	Meas BW
A. On	2.515	3.485	30.00	-71.07	-71.07	Man	-35.23	-49.78	1
B. On	4.000	7.500	1000.0	-55.84	-55.84	Man	-35.50	-39.00	1
C. On	7.500	8.500	1000.00	-55.84	-55.84	Man	-39.00	-49.00	1
D. On	8.500	12.000	1000.00	-55.84	-55.84	Couple	-49.00	-49.00	1
E. Off	12.500	15.000	1000.00	-55.84	-55.84	Couple	-49.00	-49.00	1

a. **Abs Stop** is set to **Couple** and **Fail Mask** is set to **Abs AND Rel**.

Table 4-3 Offsets & Limits Defaulted for 802.11a and HiperLAN/2 Radio Standards^a

Offset	Start Freq (MHz)	Stop Freq (MHz)	Abs Start (dBm)	Abs Stop (dBm)	Abs Couple	Rel Start (dBc)	Rel Stop (dBc)	Rel Couple	Meas BW
A. On	9.00	11.00	16.00	-4.00	Man	0.00	-20.00	Man	1
B. On	11.00	20.00	-4.00	-12.00	Man	-20.00	-28.00	Man	1
C. On	20.00	30.00	-12.00	-24.00	Man	-28.00	-40.00	Man	1
D. On	30.00	50.00	-24.00	-24.00	Couple	-40.00	-40.00	Couple	1
E. Off	50.00	100.00	-24.00	-24.00	Couple	-40.00	-40.00	Couple	1

a. **Res BW** is set to 100 kHz and **Fail Mask** is set to **Rel**.

Table 4-4 Offsets & Limits Defaulted for 802.11b Radio Standard^a

Offset	Start Freq (MHz)	Stop Freq (MHz)	Abs Start (dBm)	Abs Stop (dBm)	Rel Start (dBc)	Rel Stop (dBc)	Meas BW
A. On	11.00	22.00	-10.00	-10.00	-30.00	-30.00	1
B. On	22.00	50.00	-30.00	-30.00	-50.00	-50.00	1
C. Off	50.00	70.00	-30.00	-30.00	-50.00	-50.00	1
D. Off	70.00	90.00	-30.00	-30.00	-50.00	-50.00	1
E. Off	90.00	100.00	-30.00	-30.00	-50.00	-50.00	1

a. **Res BW** is set to 100 kHz, **Fail Mask** is set to **Rel**, and **Abs Stop** and **Rel Stop** are both set to **Couple**.

Offset

Select the offset pairs (upper and lower) that the softkeys will affect, and displays the memory selection menu from **A** to **E** (the analyzer can store up to 5 sets of values for **Start Freq**, **Stop Freq**, **Sweep Time**, **Res BW**, **Meas BW**, **Abs Start**, **Abs Stop**, etc.). Press **Offset** to select the letter of the desired offset is underlined. Only one selection at a time is shown on this key label.

Key access: **Meas > SEM > Offset/Limits**

Start Freq On Off	<p>Specifies the inner limit (frequency closest to the carrier) for both segments of the specified offset pair. When Start Freq (Off) is selected, the offset pair is not measured.</p> <p>Key access: Meas > SEM > Offset/Limits</p>
Stop Freq	<p>Specifies the outer limit (frequency furthest from the carrier) for both segments of the specified offset pair. The minimum frequency difference between Start Freq and Stop Freq is limited to 100 Hz.</p> <p>Key access: Meas > SEM > Offset/Limits</p>
Sweep Time Auto Man	<p>Specifies the sweep time for the currently selected offset, and toggles this function between Auto and Manual for each offset.</p> <p>Key access: Meas > SEM > Offset/Limits</p>
Res BW Auto Man	<p>Specifies the resolution bandwidth used in measuring the offset pair. When set to Auto, the Res BW are used. When set to Man, the allowed range is 1 kHz to 1MHz.</p> <p>Key access: Meas > SEM > Offset/Limits</p>
Abs Start	<p>To enter an absolute level limit at Start Freq for the currently selected offset ranging from -200.00 to +50.00 dBm with 4 significant digits.</p> <p>Key access: Meas > SEM > Offset/Limits > More</p>
Abs Stop Couple Man	<p>To enter an absolute level limit at Stop Freq for the currently selected offset ranging from -200.00 to +50.00 dBm with 4 significant digits, and to toggle this function between Couple and Man. If set to Couple, this is coupled to Abs Start to make a flat limit line. If set to Man, Abs Start and Abs Stop the user can enter different values to make a sloped limit line.</p> <p>Key access: Meas > SEM > Offset/Limits > More</p>
Rel Start	<p>Enters a relative level limit at Start Freq ranging from -150.00 to +50.00 dBc with 4 significant digits.</p> <p>Key access: Meas > SEM > Offset/Limits > More</p>

- Rel Stop Couple Man** Enters a relative level limit at **Stop Freq** ranging from -150.00 to +50.00 dBc with 4 significant digits, and to toggle this function between **Couple** and **Man**. If set to **Couple**, this is coupled to **Rel Start** to make a flat limit line. If set to **Man**, **Rel Start** and **Rel Stop** the user can enter different values to make a sloped limit line.
Key access: **Meas > SEM > Offset/Limits > More**
- Fail Mask** Displays the menu to select one of the following logic keys for fail conditions between the measurement results and the test limits: **Absolute**, **Relative**, **Abs AND Rel**, and **Abs OR Rel**.
Key access: **Meas > SEM > Offset/Limits > More > More**
- Absolute** Sets the limit test to show Fail if one offset is larger than the corresponding limit for **Abs Start** and/or **Abs Stop**. This is the default selection for each offset for BTS measurements.
- Relative** Sets the limit test to show Fail if one offsets spectrum emission mask measurement results is larger than the corresponding limit for **Rel Start** and/or **Rel Stop**.
- Abs AND Rel** Set the limit test to show Fail if one offset's spectrum emission mask measurement results is larger than both the corresponding limit for **Abs Start** and **Abs Stop** and the limit for **Rel Start** and **Rel Stop**.
- Abs OR Rel** Set the limit test to show Fail if one offset's the absolute spectrum emission mask measurement results is larger than the corresponding limit for **Abs Start** and **Abs Stop** or the limit for **Rel Start** and **Rel Stop**.
- Meas BW** Specifies the bandwidth to use when measuring the offset. When using the front panel, only the currently selected offset is affected. All the offsets are affected when remote control. This is the multiplier applied to the resolution bandwidth to determine the bandwidth to integrate when calculating the power. Meas BW is restricted to be 1 and not changeable.
Key access: **Meas > SEM > Offset/Limits > More > More**

MODE

Selects the measurement mode of your analyzer.

Spectrum Analyzer mode is the default mode and is for general purpose measurement use.

Tracking Generator

Accesses the tracking generator functions. (Option TG3)

Key access: **Mode**

Amplitude Toggles the tracking generator output between on and off. The power level can then be adjusted using the numeric keypad, arrow keys or knob. Pressing any digit, 0 through 9, on the numeric keypad brings up the selected terminator menu. The output level range is -30 dBm to 0 dBm. When Amplitude (Off) is selected, the output attenuation is set to the maximum attenuation.

Key access: **Mode > Tracking Generator**

CAUTION

Power-level sensitive devices connected to the tracking generator output may be accidentally damaged. This is because the actual source amplitude will be greater than the amplitude indicated on the analyzer, when the power sweep function is being used. The source amplitude value is used as the starting amplitude for a power sweep. The ending amplitude for a power sweep is higher than the source amplitude value and it may actually be set to values beyond specified output levels. Therefore, exercise caution when connecting a power-level sensitive device to the tracking generator output.

Amptd Step Sets the step size of the power level range of the tracking generator. The default setting is one vertical scale division when in a logarithmic amplitude scale.

Key access: **Mode > Tracking Generator**

Amptd Offset offsets the displayed power of the tracking generator. Using the amplitude offset capability of the tracking generator allows you to take system losses or gains into account, thereby displaying the actual power delivered to the device under test.

Key access: **Mode > Tracking Generator**

Normalize access a submenu to set the parameters as below.

Store Ref (1->3) Copies trace 1 into trace 3. Softkey menu **Store Ref (1->3)** must be pressed before pressing **Normalize (On)**.

Normalize On Off Activates the normalize function. On each sweep, the normalized trace (Trace 3) is subtracted from Trace 1 and the result is added to the normalized reference level.

The trace data is normalized with respect to the normalized reference level, even if the value of the normalized reference level is changed. This function remains in effect on all subsequent sweeps until it is turned off.

The normalize function is most useful for applying correction data to a trace while making a stimulus response measurement with a tracking generator. For example, connect the cables and a thru line, in place of the device to be measured, between the tracking generator and the analyzer input. Notice that the frequency response is not perfectly flat, showing the response of the cables, as well as the flatness of both the tracking generator and the analyzer. Now press **Store Ref (1->3)**, **Normalize (On)**. Notice that the displayed trace is now flat, or normalized. The position of the normalized trace can now be moved to a different position on the display by changing the normalized reference position. This may be useful if the device to be tested has positive gain, such as an

amplifier. Now, replace the thru line with the device under test, and an accurate measurement of the gain or loss can be made.

Norm Ref Lvl Sets the level (in dB) of the normalized reference.

Norm Ref Posn Offsets the displayed trace without affecting the instrument gain or attenuation settings. This allows the displayed trace to be moved without decreasing measurement accuracy. The normalized reference position is indicated with a (>) character on the left side of the display and a (<) character on the right side of the display.

Ref Trace View Blank Allows you to view or blank the reference trace on the display.

NOTE

When in the Tracking Generator mode, resolution bandwidths < 30 kHz are not available.

Power Meter

Press **Mode > Power Meter** to access the optional power meter functions. When this mode is selected, the power meter related softkey menu will be displayed and many of the instrument hardkeys will be disabled as they are not necessary for this mode.

Mode toggles the measurement between AVG and Peak. When it is set to AVG, the result showned in screen is the power sensor's measurement result. When it is set to Peak, the result shown in screen is the power sensor's gate measurement result.

Key access: **Mode > Power Meter**

Zeroing Accesses the associated Zeroing submenu.

Key access: **Mode > Power Meter**

Zeroing Makes a Zero operation of the power sensor.

The U2000 Series USB Power Sensors have their sensor calibration tables stored in non-volatile memory which means that the reference calibration factor is automatically loaded upon power-up.

Key access: **Mode > Power Meter > Zero/Cal**

Zero Type Toggles the zeroing type of the Power Sensor between internal and external. When this type is set to **EXT**, pressing **Zero** will bring up a message which indicates the external signal need be pulled out. This setting is not affected by the preset in Power Meter menu.

Key access: **Mode > Power Meter > Zero/Cal**

Calibration Toggles the zeroing type of the Power Sensor between internal and external. When this type is set to **EXT**, pressing **Zero** will bring up a message which indicates the external signal need be pulled out. This setting is not affected by the preset in Power Meter menu.

Key access: **Mode > Power Meter > Zero/Cal**

Meas Disp Accesses the Meas Disp submenu for defining the display range and resolution while in Power Meter mode.

Key access: **Mode > Power Meter**

Disp Accesses the associated Disp Range submenu.

Range Key access: **Mode > Power Meter > Meas Disp**

Auto Range Toggles the auto range function between On and Off. When the Auto Range is set to On, the Top and Bottom value of the power meter's display range will be set automatically according to the measurement data:

Top = Max. data + 0.5

Bottom = Min. data - 0.5

The default setting is Off.

Top Sets the top value of the power meter' display range.

Range from (Bottom + 0.01) to 200 dBm.

The default value is 20 dBm.

Bottom Sets the bottom value of the power meter' display range.

Range from - 200 to (Top - 0.01) dBm.

The default value is - 70 dBm.

Resolution Accesses the associated Resolution submenu.

1 2 3 4

When the measurement suffix is W or %, this parameter represents the number of significant digits. When the measurement suffix is dB or dBm, 1 through 4 represents 1, 0.1, 0.01, and 0.001 dB respectively. The default value is 3.

Key access: **Mode > Power Meter**

General Setup Accesses the power meter measurement setup submenu.

Key access: **Mode > Power Meter**

Dis Mode Changes the display mode between **Meter** and **Chart**.
Meter Chart The default mode is Meter.

Key access: **Mode > Power Meter > Meas Setup**

Chart View Accesses the Chart View submenu. This soft key is disabled when the measurement is in process or if the display mode is set to **Meter**.

This submenu is used to view the measurement chart.

Key access: **Mode > Power Meter > Meas Setup**

Home View the first 21 points of current measurement chart.

End View the last 21 points of current measurement chart.

Prev View the previous points of the chart.

- Next** View the next points of the chart.
- Pause/Continue** Continues or pauses the current measurement. When the measurement is in process, this softkey is displayed as “Pause”; when the measurement is paused, the softkey is displayed as “Continue”.
Key access: **Mode > Power Meter > Meas Setup**
- Preset** Sets the power meter softkey menu options to the preset conditions. For example, the upper and lower limits are set to their preset limit values.
Key access: **Mode > Power Meter**

Spectrum Monitor

- Press **Mode > Spectrum Monitor** to access the submenu listed as below:
- Spectrogram Run/Pause** Toggles the spectrogram monitoring between **Run** and **Pause**.
Key access: **MODE > Spectrum Monitor**
 - Restart Meas** Resets the spectrogram display.
Key access: **MODE > Spectrum Monitor**
 - Update Interval** Enables you to set the interval of time to update data to 1 or more seconds. Or, you may set it to automatically determine the Update Interval that provides the maximum data collection speed.
A data sample is taken every time interval for display on the spectrogram. Increasing the update time allows data capturing over a longer period of time in the spectrogram.
Key access: **MODE > Spectrum Monitor**

- Spec View** Enables you to view the details in the captured spectrogram. when the Spectrogram is running, Pressing **Spec View** pauses the running spectrogram.
Press **Home/End** to view the first /last spectrogram in cache.
Press **Playback** to playback the spectrogram process. The direction and the update interval is changeable as your need.
Key access: **MODE > Spectrum Monitor**
- Palette** Toggles the spectrogram color mode between full color and gray scale.
Key access: **MODE > Spectrum Monitor**
- Disp Mode** Allows you to set the spectrogram display mode as trace, spectrogram or both trace and spectrogram.
Key access: **MODE > Spectrum Monitor**
- File Logging** Accesses the submenu for spectrogram file operation.
- **Start/Stop Save**
This softkey allow you to start or stop the automatic save function. Once the spectrogram measurement frames reached the file size set in the **File Size**, a file (*.SPE or *.CSV) will be automatically saved, and the spectrogram measurement will restart.
Key access: **MODE > Spectrum Monitor**
- NOTE** The save process takes a few seconds to read from cache. During this period, the measurement is paused.

- **Timed Setting**

This submenu allows you to configure automatic time save function. You can set start date, time, stop date, time in this menu. Press **{Timed Save On}**, the analyzer will start the auto-saving function from the **Start Time**.

- **File Type**

Toggles the saved file type between trace and CSV.

- **File Path**

Allocate the path where the file is saved.

- **File Size**

Set the number of frames for the spectrogram trace file. The allowed input range is 200 to 1500 frames.

Reflection Measurement

The reflection measurement mode provides the reflection measurement, one port cable loss and distance to fault measurement function.

Auto Scale

Press this softkey to adjust the amplitude scale automatically to include the peak and valley level in graticule.

Key access: **Amplitude > Auto Scale**

Calibrate

This softkey activates the calibration process for the measurement.

Key access: **Frequency > Calibrate**

Cal Type

This softkey toggles the calibration type between full span calibration and selected span calibration.

Full span calibration runs an open-short-load calibration across the full frequency span.

A FullSpan calibration ignores the frequency changes during measurements.

Selected span calibration performs an open-short-load calibration across a user-defined frequency span. A SelectedSpan Cal requires a re-calibration of the analyzer,

after changing the measurement frequency range. Normally, the selected span should be set as close to the actual swept frequency range.

Key access: **Freq > Cal Type**

Run/Hold

This softkey toggles the frequency sweep between run and pause status.

Key access: **Sweep > Run/Hold**

Data->Mem

This softkey is used to store the active data trace into memory. The trace in memory will be refreshed in the next sweep once you press this softkey. There are three trace refresh mode for your selection:

Data Only the activated trace is viewable. The trace memory is not viewable.

Memory Only the trace in memory is viewable.

Data&Memory The trace both activated and in memory is viewable.

Key access: **Trace > Data->Mem**

Disp Mode

This softkey allows you to set the Y axis of the graticule as return loss, VSWR or reflection coefficient value.

Key access: **Meas > Disp Mode**

IIM On/Off

This softkey toggles IIM between on and off. When there is a need to measure the antenna feed line in field, there are probably some interference signals coupled into the device, which will be detected as spurs in the measurement result. When IIM is set to on, the analyzer will compensate those spurs by IIM algorithm.

Key access: **Meas > IIM**

AM/FM Modulation Analysis

Use the arrow keys to highlight the mode you need and press [ENTER] as a terminator. When this mode is selected, the AM/FM modulation analysis menu will be displayed.

- Carrier Freq** Sets the modulated carrier frequency.
Key access: **Mode > AM/FM Modulation Analysis**
- IFBW** This specifies the IF bandwidth for the signal to be analyzed. The measurement accuracy will be impacted if this value isn't set precisely.
Key access: **Mode > AM/FM Modulation Analysis**
- EqLPF** This specifies the IF bandwidth for the signal to be analyzed. The measurement accuracy will be impacted if this value isn't set precisely.
Key access: **Mode > AM/FM Modulation Analysis**
- Filter Setup** Accesses the Filter setup submenu for further configuration.
Key access: **Mode > AM/FM Modulation Analysis**
- Meas Filter** Selects the Measure Filter as Root Nyquist, Nyquist, and Gaussian.
- Ref Filter** Selects the Measure Filter as Root Nyquist, Nyquist, and Gaussian.
- Alpha/BbT** Sets the root-off factor α for Root Nyquist and Nyquist filter or BbT for Gaussian filter.
- Filter Symbols** Sets the symbol numbers for the selected filter. The allowed value range is from 2 to 25.
- View** Accesses the submenu to select four display mode:
Symbol - displays the binary symbol in full screen/window.

- Waveform - displays the signal waveform.
- AM Error - displays the AM error.
- Eye Diagram - Displays the Eye diagram.
- Key access: **Mode > AM/FM Modulation Analysis**
- X Scale** Accesses the submenu to configure the X scale parameters:
Scale/Div sets the number of symbols in one division.
Ref Value sets the starting value in term of times at the reference position.
Ref position sets the display reference position to either Left, Ctr (center), or Right. If the **Auto scale** key is set to on, these parameters are adjusted automatically according to the measurement result.
 Key access: **Mode > AM/FM Modulation Analysis**
- Y Scale** Accesses the submenu to configure the X scale parameters:
Scale/Div sets the number of symbols in one division.
Ref Value sets the starting value in term of times at the reference position.
Ref position sets the display reference position to either Top, Ctr (center), or Bottom.
 The **Ext Gain** is set to add the external gain to the test result. If the **Auto scale** key is set to on, these parameters are adjusted automatically according to the measurement result.
 Key access: **Mode > AM/FM Modulation Analysis**
- Meas Length** Sets the number of symbols which will be used in calculating the measurement.
 Key access: **Mode > AM/FM Modulation Analysis > More**
- Average On Off** Specifies the display measurement result format. When the Average Number is set to off, the column title "Average" in numerical results view will be changed to "Current".
 Key access: **Mode > AM/FM Modulation Analysis > More**

Trigger Enables you to configure the trigger. When using a trigger source other than Free Run, the analyzer will begin a sweep only with the selected trigger conditions are met. A trigger event is defined as the point at which your trigger source signal meets the specified trigger level.

Free Run - New sweep starts as soon as possible after the current sweep ends.

RF Trigger - Activates the trigger condition that starts the next sweep if the detected RF envelope voltage rises to a level set by the RF trigger level.

Ext Rise/Fall - Activates the trigger condition that will start a sweep when the external voltage passes through 2 volts. The external trigger signal must be a 0 V to +5 V TTL signal. Sets the trigger polarity to positive/negative.

Trig Delay - Allows you to set and turn on or off a delay, during which the analyzer will wait to begin a sweep after receiving an external trigger signal.

Key access: **Mode > AM/FM Modulation Analysis > More**

Limits Set a limit value to warn you if the measured value exceeds the value specified here. The test result will be in purple if this result exceeds the corresponding limit value.

Limit - Turns on/off the limit function

CarrPow Upr - Sets the carrier power upper limit

FreqDev Up/Low - Sets the frequency deviation upper/lower limit

CarrFreOff Up - Sets the carrier frequency offset upper limit

Key access: **Mode > AM/FM Modulation Analysis > More**

Sweep Toggle the sweep type between single and continuous in AM/FM mode. When this softkey is set to Single, press the next **Single** softkey to execute a new sweep as soon as the trigger condition is met.

Key access: **Mode > AM/FM Modulation Analysis > More**

- Single** When the analyzer is in continuous sweep mode, pressing this softkey will change the sweep setting to single sweep. It will then begin a sweep after the trigger conditions are met.
- If the analyzer is already in single sweep, pressing this softkey will execute a new sweep as soon as the trigger condition is met.
- If average is on pressing this softkey will halt averaging of the current value, and then continue averaging from the current count number when a single sweep function triggers.
- Key access: **Mode > AM/FM Modulation Analysis > More**
- CarrFreq Step** Changes the step size for the center frequency function. Once a step size has been selected and the center frequency function is activated, the arrow keys change the center frequency by the step-size value. The step size function is useful for finding harmonics and sidebands beyond the current frequency span of the analyzer.
- Key access: **Mode > AM/FM Modulation Analysis > More > More**
- Auto CarrFreq On Off** This function can remedy the carrier frequency deviation when the deviation less than symbol rate 5.
- Key access: **Mode > AM/FM Modulation Analysis > More > More**

ASK/FSK Modulation Analysis

Use the arrow keys to highlight the mode you need and press **[ENTER]** as a terminator. When this mode is selected, the ASK/FSK modulation analysis menu will be displayed.

- Carrier Freq** Sets the modulated carrier frequency.
Key access: **Mode > ASK/FSK Modulation Analysis**
- Symbol Rate** This specifies the fundamental symbol rate of the signal to be analyzed. The values should be positive. The non-positive value will be converted to 1Hz. The measurement accuracy will be impacted if this value isn't set precisely.
Key access: **Mode > ASK/FSK Modulation Analysis**
- Filter Setup** Accesses the Filter setup submenu for further configuration.
Key access: **Mode > ASK/FSK Modulation Analysis**
- Meas Filter** Selects the Measure Filter as Root Nyquist, Nyquist, and Gaussian.
- Ref Filter** Selects the Measure Filter as Root Nyquist, Nyquist, and Gaussian.
- Alpha/BbT** Sets the root-off factor α for Root Nyquist and Nyquist filter or BbT for Gaussian filter.
- Filter Symbols** Sets the symbol numbers for the selected filter.
The allowed value range is from 2 to 25.
- View** Accesses the submenu to select four display mode:
Symbol - displays the binary symbol in full screen/window.
Waveform - displays the signal waveform.
ASK Error - displays the ASK error.
Eye Diagram - Displays the Eye diagram.
Key access: **Mode > ASK/FSK Modulation Analysis**

- X Scale** Accesses the submenu to configure the X scale parameters:
Scale/Div sets the number of symbols in one division.
Ref Value sets the starting value in term of times at the reference position.
Ref position sets the display reference position to either Left, Ctr (center), or Right. If the **Auto scale** key is set to on, these parameters are adjusted automatically according to the measurement result.
 Key access: **Mode > ASK/FSK Modulation Analysis**
- Y Scale** Accesses the submenu to configure the X scale parameters:
Scale/Div sets the number of symbols in one division.
Ref Value sets the starting value in term of times at the reference position.
Ref position sets the display reference position to either Top, Ctr (center), or Bottom.
 The **Ext Gain** is set to add the external gain to the test result. If the **Auto scale** key is set to on, these parameters are adjusted automatically according to the measurement result.
 Key access: **Mode > ASK/FSK Modulation Analysis**
- Meas Length** Sets the number of symbols which will be used in calculating the measurement.
 Key access: **Mode > ASK/FSK Modulation Analysis > More**
- Average On Off** Specifies the display measurement result format. When the Average Number is set to off, the column title "Average" in numerical results view will be changed to "Current".
 Key access: **Mode > ASK/FSK Modulation Analysis > More**

Trigger Enables you to configure the trigger. When using a trigger source other than Free Run, the analyzer will begin a sweep only with the selected trigger conditions are met. A trigger event is defined as the point at which your trigger source signal meets the specified trigger level.

Free Run - New sweep starts as soon as possible after the current sweep ends.

RF Trigger - Activates the trigger condition that starts the next sweep if the detected RF envelope voltage rises to a level set by the RF trigger level.

Ext Rise/Fall - Activates the trigger condition that will start a sweep when the external voltage passes through 2 volts. The external trigger signal must be a 0 V to +5 V TTL signal. Sets the trigger polarity to positive/negative.

Trig Delay - Allows you to set and turn on or off a delay, during which the analyzer will wait to begin a sweep after receiving an external trigger signal.

Key access: **Mode > ASK/FSK Modulation Analysis > More**

Limits Set a limit value to warn you if the measured value exceeds the value specified here. The test result will be in purple if this result exceeds the corresponding limit value.

Limit - Turns on/off the limit function

CarrPow Up - Sets the carrier power upper limit

FreqDev Up/Low - Sets the frequency deviation upper/lower limit

CarrFreOff Up - Sets the carrier frequency offset upper limit

Key access: **Mode > ASK/FSK Modulation Analysis > More**

Sweep Toggle the sweep type between single and continuous in ASK/FSK mode. When this softkey is set to Single, press the next **Single** softkey to execute a new sweep as soon as the trigger condition is met.

Key access: **Mode > ASK/FSK Modulation Analysis > More**

- Single** When the analyzer is in continuous sweep mode, pressing this softkey will change the sweep setting to single sweep. It will then begin a sweep after the trigger conditions are met. If the analyzer is already in single sweep, pressing this softkey will execute a new sweep as soon as the trigger condition is met. If average is on pressing this softkey will halt averaging of the current value, and then continue averaging from the current count number when a single sweep function triggers. Key access: **Mode > ASK/FSK Modulation Analysis > More**
- CarrFreq Step** Changes the step size for the center frequency function. Once a step size has been selected and the center frequency function is activated, the arrow keys change the center frequency by the step-size value. The step size function is useful for finding harmonics and sidebands beyond the current frequency span of the analyzer. Key access: **Mode > ASK/FSK Modulation Analysis > More > More**
- Auto CarrFreq On Off** This function can remedy the carrier frequency deviation when the deviation less than symbol rate 5. Key access: **Mode > ASK/FSK Modulation Analysis > More > More**

Peak Search

Places a marker on the highest peak based on the settings of the **“Peak Criteria”** on page 149.

NOTE

All peak search functions ignore the LO feed through signal. The process for determining if the Peak is the LO feed through takes into account Start Frequency, Span, Resolution Bandwidth, Resolution Bandwidth shape factor, and Frequency Accuracy. If there is no point of inflection within the LO feed through range, the point on the trace with maximum amplitude, that is higher in frequency than the LO feed through, will be selected.

-
- | | |
|----------------------|--|
| Peak Search | Performs peak search as described above.
Key access: Peak Search |
| Next Peak | Places the marker on the next highest peak. The signal peak must exceed the peak threshold value by the peak excursion value. If there is no peak, the marker will not move.
Key access: Peak Search > Next Peak |
| Next Left PK | Moves the marker to the next peak to the left of the current marker position. The signal peak must exceed the peak threshold value by the peak excursion value. If there is no peak to the left, the marker will not move and the “No Peak Found” error message will appear on the display.

Key access: Peak Search > Next Left Peak |
| Next Right PK | Moves the marker to the next peak to the right of the current marker position. The signal peak must exceed the peak threshold value by the peak excursion value. If there is no peak to the right, the marker will not move and the “No Peak Found” error message will appear on the display.

Key access: Peak Search > Next Right Peak |

- Pk-Pk Search** Finds and displays the frequency (or time, if in zero span), and amplitude differences between the highest and lowest trace points.
Key access: **Peak Search > Pk-Pk Search**
- To Center** This is a hot key of marker to center.
Key access: **Peak Search > Pk-Pk Search**
- Continuous Pk On Off** When **Continuous Pk** is **on**, the marker will remain on the peak signal even if the frequency of that signal changes. The marker will remain on that signal as long as the amplitude of the signal does not change by more than 3 dB from one sweep to another.
If the signal is lost, the marker will attempt to find it again and maintain on the peak. If there are other signals on screen near the same amplitude, one of them may be found instead. Signals near 0 Hz cannot be maintained effectively.
This function is intended to maintain the marker on signals with a frequency that is changing, and an amplitude that is not changing.
Key access: **Peak Search > Continuous PK**
- Peak Table** **Peak Table** Displays a list of up to ten signal peaks that is updated at the end of each sweep. The peaks can be sorted in order by descending amplitude or by ascending frequency. Peaks above or below the display line can be excluded from the table. The peak table function works with trace 1 only.
Exprt Table to CSV Press this softkey to save the current peak table to a CSV file for your data analysis on PC.
Key access: **Peak Search > More**
- Peak Criteria** Accesses the submenu to set the criteria for peak search.
Key access: **Peak Search > More**

Peak Excursion Sets the minimum amplitude variation of signals that the marker identifies as a peak. If a value of 10 dB is selected, the marker moves only to peaks that rise and fall more than 10 dB above the peak threshold value. When the peak excursion is 6 dB or higher,

NOTE

Two signal peaks, which are so close together that the amplitude drop between them is less than the peak-excursion value, are not recognized as two peaks. A signal peak is recognized only if it has a peak excursion drop above the noise floor, on both sides of the signal.

the marker-peak does not recognize signals less than peak-excursion value above the noise floor. To correct this, when measuring signals near the noise floor, reduce the excursion value. To prevent the marker from identifying noise as signals, reduce the noise floor variance less than the peak-excursion value by reducing the video bandwidth or by using video averaging.

Key access: **Peak Search > More**

Peak Threshold

Sets the minimum amplitude that the marker can identify as a peak. For example, if set to -90 dBm, the marker moves only to peaks that rise and fall more than the peak excursion above -90 dBm. Only functional when in Excursion and Threshold marker mode.

Key access: **Peak Search > More**

Peak Type

Toggles the peak type between maximum value and minimum value.

Key access: **Peak Search > More**

System

This softkey accesses the submenu to set the system and utility settings.

Time/Date accesses the **Time/Date** menu keys used to set and display the time and date.

Key access: **System > Time/Date**

Language chooses the 11 languages for softkeys display.

Key access: **System > Time/Date**

Pwr on/Preset Accesses the following softkeys for the preset settings.

Key access: **System > Pwr On/Off**

Power on Determines the state of the analyzer when the **DFT User Last** analyzer is turned on. **Power On** set to **Preset** recalls the analyzer settings previously with the **Preset** function. **Power On** set to **Last** recalls the analyzer settings when the analyzer is turned off by the front panel power switch.

Preset Type Selects **User** or **Factory** preset settings.

User Pressing **Preset** recalls the analyzer settings defined by **Save User Preset**.

Factory Pressing **Preset** recalls the analyzer settings originally set at the factory.

Last Pressing **Preset** recalls the analyzer settings to the last time power-off.

Save User Saves the active settings of the analyzer into the User Preset register. To recall these settings, select **Preset Type** to **User**.

System Info Accesses the submenu to check the system information as below.

Key access: **System > More**

Show System Displays the number and description of the options installed in your analyzer. It also displays the instrument model number, product number, serial number, the date of production, etc.

Installed Options displays the installed option list.

Error History Accesses a list of the 100 most recent errors reported. The most recent error will appear at the bottom of the list. If the same error occurs continuously, that error message will not be added repeatedly to the list. Refer to [“Instrument Messages”](#) on page 167 for details.

Prev Page/ Access the previous/next page of error
Next Page messages.

Clear Error Queue Clears all the errors in the errors queue.

Service Accesses the submenu to set the service settings as below.

Key access: **System > More > Service**

Calibration Accesses the submenu to calibrate the time base of the analyzer, load default values for the alignment system.

Time Base Calibrates the time base of the analyzer
by Ext with external source.

Amp Adjust the amplitude accuracy according
Alignment the internal cal out signal.

CAL OUT Turns the internal amplitude reference
On Off signal on or off. When this signal is on, the
RF input is disabled.

Upgrade Enables the firmware upgrade process once the USB disk with the firmware upgrade package plug connected.

Diagnostics Accesses the **Front Panel** softkey to verify the functionality of each front-panel key. The number next to each key name increments once each time the key is pressed. Rotating the knobs causes the number of pulses to be counted. Press **Return** will go back to the main menu.

Add Option Accesses the security system to enable licensing for individual options. A user may not turn off an option using this system. Once an option has been licensed for a given analyzer, it cannot be transferred to a different analyzer.

Port Setting Access the submenu to set the ports as below.
Key access: **System > More > Port Setting**

Ip Config Toggles the IO port between **USB, LAN** and **GPIB(option)** for remote control.

Probe Power Provides power for high-impedance AC probes or other accessories (+15 V, -12V, 150 mA maximum).
Key access: **System > More > Port**

GPIB Address sets the GPIB address (option G01 required).

Span

Accesses the span function and the submenu softkeys for span functions. Pressing **Span** changes the frequency range symmetrically about the center frequency. The frequency-span readout describes the total displayed frequency range. To determine frequency span per horizontal graticule division, divide the frequency span by 10.

- Span** Enter the span frequency range value.
Key access: **Span**
- Full Span** Changes the span to full span showing the full frequency range of the analyzer.
Key access: **Span**
- Zero Span** Changes the frequency span to zero. In this mode, the current center frequency is displayed in the time domain (the x-axis is displayed in units of time), like a conventional oscilloscope.
Key access: **Span**
- Last Span** Changes the span to the previous span setting.
Key access: **Span**

Sweep

Sweep Time Auto Man

Accesses the Sweep softkeys for selection of the sweep mode and trigger mode of the analyzer. The softkey menu selections are defined as follows:

Selects the sweep time for the analyzer to tune across the displayed frequency span (or, in zero span, the time the analyzer take to sweep the full screen).Inputs may be made using the knob, the arrow keys, or numeric keypad.

In non-zero spans

When the sweep time is auto-coupled, the analyzer selects the optimum (shortest) sweep time ranging from 10 ms to 1000 s. The auto selection is determined by three measurement settings:

- Frequency Span
- The selected Resolution Bandwidth
- The selected Video Bandwidth

Note that changing one of the three factors above will change the sweep time. The sweep time is in direct ratio to frequency span and is in reverse ratio to the selected resolution bandwidth and video bandwidth when auto-coupled.

CAUTION

With sweep time set to a value less than the minimum auto-coupled value, an annotation “Data out of range” appears in the active function block and the sweep time is automatically converted to the minimum auto-coupled value.

In zero span

Auto-coupled does not function when in a zero span. The sweep time can only be set manually. The sweep time is selectable from 6 s to 200 s in zero span.

In FFT Mode

In FFT mode, the sweep time default is auto-coupled. The submenu, sweep time is invalid in FFT mode.

Key access: **Sweep**

Sweep Single Cont

Pressing **Sweep Single** puts the analyzer in single-sweep mode. Press **Sweep Single** to initiate a sweep when in single-sweep mode. Press **Sweep Cont** Performs one sweep after another as soon as it is triggered. Pressing **Preset** (When **Preset Type** is set to **Factory**) sets the sweep mode to continuous sweep.

Key access: **Sweep**

Single Sweep

When the analyzer is in continuous sweep mode and not in a measurement mode (**MEAS > Measure Off**), pressing **Sweep > Single Sweep** will change the sweep setting to single sweep. It will then begin a sweep after the trigger conditions are met. If the analyzer is already in single sweep, pressing **Sweep > Single Sweep** will execute a new sweep as soon as the trigger condition is met.

If average is on (**TRACE > More > Average Number On**), pressing **Sweep > Single Sweep** will halt averaging of the current value, and then continue averaging from the current count number when a single sweep function triggers.

Key access: **Sweep**

Trigger

Accesses the menu of keys that allow you to select the trigger mode of the analyzer. This softkey is only available in zero span.

Free Run New sweep starts as soon as possible after the current sweep ends.

Video Activates the trigger condition that starts the next sweep if the detected RF envelope voltage rises to a level set by the video trigger level. When **Video** is pressed, a line appears on the display. The analyzer triggers when the input

signal exceeds the trigger level at the left edge of the display. Change the trigger level by using the arrow keys, the knob, or the numeric keypad.

NOTE

This function is not available when the Resolution Bandwidth is less than 1 kHz. Selecting a Resolution Bandwidth less than 1 kHz while in Video Trigger mode, changes the Trigger mode to Free Run.

External Activates the trigger condition that will start a sweep when the external voltage (connected to **EXT TRG IN** on the rear panel) passes through approximately 2 volts. The external trigger signal must be a 0 V to +5 V TTL signal.

Key access: **Trace > More**

Gated Sweep The analyzer provides two sweep time rules to meet the different sweep time requirements:

Gate View

Toggles the Sweep type between Sweep and FFT mode. The default setting is sweep mode.

View SweepTime

Toggles the Sweep type between Sweep and FFT mode. The default setting is sweep mode.

Gate Delay

Toggles the Sweep type between Sweep and FFT mode. The default setting is sweep mode.

Gate Length

Toggles the Sweep type between Sweep and FFT mode. The default setting is sweep mode.

Gate Source

Toggles the Sweep type between Sweep and FFT mode. The default setting is sweep mode.

- Swp Time Rule** The analyzer provides two sweep time rules to meet the different sweep time requirements:
- **Speed**
Activates the default fast sweep time rule.
 - **Accuracy**
Activates the normal sweep time rule to ensure the measurement accuracy.
- Speed sweep time rule provides a fast measurement function that decreases the sweep time. Using Fast Sweep will decrease the measurement accuracy.
- Key access: **Sweep > Sweep Setup**
-
- Sweep Type** This softkey toggles the Sweep Type between swept mode and FFT mode. This FFT mode is only available when RBW is set to 1 kHz, 3 kHz, or 10 kHz.
- Swept FFT**
- Key access: **Sweep > Sweep Setup**

Limit

Limits Accesses softkeys that allow you to control and define the parameters of limit lines.

Key access: **Shift** > **Limit**

Limit 1 selects either of the available limits. The **Limit 1** and **Limit 2** **Limit 2** keys access softkeys to set parameters for the selected limit.

Key access: **Shift** > **Limit**

Type defines the limit to be edited as an upper or lower limit. An upper limit will indicate a fail if trace 1 exceeds this limit. A lower limit will indicate a fail if trace 1 falls below the limit.

Key access: **Shift** > **Limit** > **Limit 1/2**

Limit On Off Toggles the limit line function to on or off. The limit points must exist before the limit function can be turned on. Either **Limit** or **Margin**, as well as **Test**, must be turned on for a limit test. Limit points must be defined before the Limit function can be turned on.

Key access: **Shift** > **Limit** > **Limit 1/2**

Test On Off Toggles the testing of the limit lines between on and off. If trace 1 is at or within the bounds of the set limit or margin, “Limit_# Pass” or “Margin_# Pass” is displayed in the upper left corner of the measurement area limit line. Only positive/negative margins are allowed for lower/upper limits. If the trace is out of the limit or margin boundaries, “Limit_# Failed” or “Margin_# Failed” is displayed. Either **Limit** or **Margin** must be turned on for test.

Key access: **Shift** > **Limit** > **Limit 1/2**

Margin On Off Toggles the margin function to on or off. Use Margin to set a limit line offset for the selected limit line. Either **Limit** or **Margin** as well as **Test**, must be turned on for a limit test to work.

Key access: **Shift** > **Limit** > **Limit 1/2**

Edit Accesses the submenu to edit the limit point, and also accesses the limits table. Use arrow keys to move between the rows in the limits table. New limit segments will only be applied after close the editor. Pressing **Return**, or any key not associated with the editor, will close the editor.

Key access: **Shift** > **Limit** > **Limit 1/2**

Point

Creates or edit a limit point. Up to 20 points can be defined for each limit line. Enter the point number using the numeric keypad, then Press **[Enter]**, or use the knob or arrow keys to move to an existing point.

Key access: **Shift** > **Limit** > **Limit 1/2** > **Edit**

Frequency

Edits the frequency value for a limit point. After editing, the limit table will place the frequency or time in correct order. For a new point, the **Amplitude** default is 0 dBm, and **Connected** default is **Yes**.

Key access: **Shift** > **Limit** > **Limit 1/2** > **Edit**

Amplitude

Sets the amplitude value for the current point.

Key access: **Shift** > **Limit** > **Limit 1/2** > **Edit**

Connected To Previous Pt**Yes No**

Defines if the current point being edited is to be connected to the previous point. Pressing this key toggles the **Connected** value between **Yes** and **No**.

Key access: **Shift** > **Limit** > **Limit 1/2** > **Edit**

Delete Point

Deletes the current point in the limit line. Pressing this key will delete the point immediately.

Key access: **Shift** > **Limit** > **Limit 1/2** > **Edit**

Delete Limit Deletes the current limit set. Pressing this key will delete the limit line entirely.
Key access: **Shift** > **Limit** > **Limit 1/2**

Delete All Limits Purges data from the limit-line tables. Pressing this key will delete all the limit line data immediately.
Key access: **Shift** > **Limit**

Trace

Accesses the trace keys to store and manipulate trace information. Each trace consists of a series of points in which amplitude data is stored. The analyzer updates the information for any active trace with each sweep.

- Trace**
1 2 3 4 Selects the trace for current use.
Key access: **Trace/Det > Trace 1 2 3 4**
- Clear Write** Erases any data previously stored in the selected trace, then continuously displays any signals during each sweep of the analyzer. This function is activated for trace 1 at power-on and **Factory Preset**.
Key access: **Trace/Det > Clear Write**
- Max Hold** Retains the maximum level for each trace point of the selected trace. Updates the trace point value if a new maximum level is detected in successive sweeps.
Key access: **Trace/Det > Max Hold**
- Min Hold** Retains the minimum level for each trace point of the selected trace. Updates each minimum trace point if a new minimum level is detected in following sweeps.
Key access: **Trace/Det > Min Hold**
- View** Holds and displays the amplitude data of the selected trace. The trace register is not updated as the analyzer sweeps. press **View** to retrieve a stored trace previously deactivated by pressing **Blank**.
Key access: **Trace/Det > View**
- Blank** Stores the amplitude data for the selected trace, then removes the trace from the display. The selected trace register no longer updates as the analyzer sweeps. To activate this function for traces 2, 3 and 4 at power-on press **Preset** (when **Preset Type** is set to **Factory** and **Factory Def**).
Key access: **Trace/Det > Blank**

**Detector
(detector type)**

Softkey presents a submenu to select a specific detector type, or allows the analyzer to select the appropriate detector for a particular measurement.

Regarding detectors, it is important to understand what is a trace “bucket”. For every trace point displayed, there is a finite time during which the data for that point is collected. The analyzer looks at all of the data collected during that time and present a single point of trace data based on the detector mode. The interval during which the data for that trace point is being collected, is called the “*bucket*”.

Thus a trace is more than a series of single points. It is actually a series of trace “buckets”. The data may be sampled many times within each bucket.

- **Average** displays the power average in the bucket.
- **Sample** displays the instantaneous level of the signal at the center of the bucket represented by each display point.
- **Positive Peak** displays the max. of the signal in the bucket.
- **Negative Peak** displays the min. of the signal in the bucket.

The detector in use is indicated on the left side of the display. A “#” will appear next to it if the detector has been manually selected.

Key access: **Shift > Dsip > More**

- | | |
|----------------------|--|
| Positive Peak | Obtains the maximum video signal between the last display point and the present display point and stores this value in memory. It’s used primarily when measuring sinusoidal components. When Positive Peak is selected, “Peak” appears in the upper-left corner. |
| Negative Peak | Is a peak detector, but selects the minimum video signal value. This detection should not be used to measure the accurate amplitude. “Npk” also appears in the upper-left corner, When Negative Peak is selected. |

- Average** measures the average value of the amplitude across each trace interval (bucket). When **Average** is selected, “Avg” appears on the left corner.
- Sample** Sample detection is used primarily to display noise or noise-like signals. It should not be used to measure the accurate amplitude of non noise-like signals. In sample mode, the instantaneous signal value of the present display point is placed in memory. When **Sample** detection is selected, “Samp” appears in the upper-left corner of the display.
- Normal** Selects the maximum and minimum video signal values alternately. When selecting **Normal** detection, “Norm” appears in the upper-left corner.

Average Number On Off Initiates a digital averaging routine that averages the trace points in a number of successive sweeps resulting in trace “smoothing”. The number of sweeps (average number) is changeable when setting **Average (Off)**. Increasing the average number will further smooth the trace. pressing **BW > Avg Type** to select the type of averaging.

To restart averaging:

- Enter a new average number
- Change any related parameter (e.g., Center Frequency)

When in **sweep single**, the specified number of averages is taken, then the sweep stops and an average trace displayed.

When in continuous sweep mode, the specified number of averages is taken, then the averaging continues with each new sweep averaged in with a weight of $\frac{1}{\text{AverageNumber}}$ and the old average reduced by multiplying it by

$$\text{AverageNumber} - \frac{1}{\text{AverageNumber}}$$

To turn averaging off, press **Average Number (Off)**.

Key access: **Trace/Det > More > Average Number On/Off**

Average Dura. On Off Initiates a digital averaging routine that averages the trace points in an average duration resulting in trace “smoothing”. Increasing the average duration will further smooth the trace.

The average is restarted when any of the following occurs:

- A new average duration is entered.
- Any related parameter (e.g., center frequency) is changed.
- **{Avg Restart}** is pressed

Press **Average Dura. (Off)** to turn off averaging.

Key access: **Trace/Det > More > Average Number On/Off**

Trace Math This softkey provides a submenu for the traces operation.

Key access: **Trace/Det > More > More > Trace Math**

Variable A, B, C Press those softkeys to select a trace (for variable A,B, and C) or a display line (for variable A and B) for the trace calculation.

A-B-> C Turn this softkey on to calculate variable A minus variable B. The result will display as variable C when all the variables is set to on. This function and **A+B->C** can not be set to on simultaneously.

A+B-> C Turn this softkey on to calculate variable A plus variable B. The result will display as variable C when all the variables is set to on. This function and **A-B->C** can not be set to on simultaneously.

Math By This softkey toggles the caculation type between power and logarithmic power. When it is set to **power**, the variable A and B will be calculated in power and the result variable C will display in converted logarithmic power. When it is set to **log power**, the variable A and B will be calculated in lograithmic power and the result variable C will display in logarithmic power.

4 Key Reference

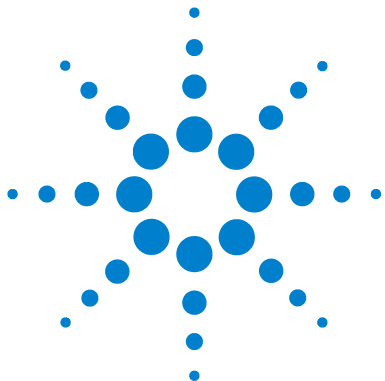

5 Instrument Messages

Overview	168
Command Errors	169
Execution Conflict	171
Device-Specific Errors	173

Overview

If an improper operation occurs during the instrument configuration, a message will appear on the status line indicating the incident and the how the spectrum analyzer corrected the setting automatically. press **System > System Info > Errors History** to read the specific descriptions of those messages.

Example

In this example, a failure explanation is generally included with each error to further define its meaning. The instrument messages in this guide are listed numerically.

<Number>	<Code>	<Message>
1.	-330	Self-test failed
		A self-test failure occurred.
		<Explanation in manual>

Command Errors

The messages listed below are command errors, which are saved into local registers.

- 100 Command error
An unrecognized command or data type was encountered. This message is used when the device cannot detect more specifics described for errors -101 to -109.
- 101 Invalid character
A syntactic element contains an invalid character.
- 102 Syntax error
An unrecognized command or data type was encountered.
- 103 Invalid separator
The parser was expecting a separator and encountered an illegal character.
- 104 Data type error
The parser recognized a data element that is not allowed.
- 108 Parameter not allowed
More parameters were received than expected for the header. For example, the *ESE common command only accepts one parameter, so receiving *ESE 0,1 is not allowed.
- 109 Missing parameter
Fewer parameters were received than required for the header. For example, the *ESE common command requires one parameter, so receiving *ESE is not allowed.
- 110 Command header error
An error was detected in the header. This message is used when the device cannot detect more specifics described for errors -111 to -119.

- 112 Program mnemonic too long
The header contains more than 12 characters.
- 113 Undefined header
The header is correct in syntax, but it is undefined for this device.
- 128 Numeric data not allowed
A legal numeric data element was received, but the device does not accept one in this position for the header.
- 130 Suffix error
This error is generated when parsing a suffix. This message is used when the device cannot detect more specifics described for errors -131 to -139.
- 131 Invalid suffix
The suffix does not follow the syntax described in *IEEE 488.2*, or the suffix is inappropriate for the device.
- 134 Suffix too long
The suffix contained more than 12 characters.
- 138 Suffix not allowed
A suffix was encountered after a numeric element which does not allow suffixes.
- 144 Character data too long
The character data element contains more than 12 characters.
- 148 Character data not allowed
A legal character data element was encountered where prohibited by the device.

Execution Conflict

The system messages listed below are execution conflicts, indicating settings conflict during your operation.

- 200 Execution Error
This is the generic syntax error for devices that cannot detect more specific errors.
- 222 Data out of range
A legal program data element was parsed but could not be executed because the interpreted value was outside the legal range defined by the device. The displayed results may be clipped.
- 223 Too much data not all points entered
Indicates that a legal program data element of block, expression, or string type was received that contained more data than the device could handle due to memory or related device-specific requirements.
- 224 Illegal parameter value
An attempt was made to select a user file that contains 0 bits. Select another user file that contains at least 1 bit.
- 241 Hardware missing
Missing device hardware. For example, the RF board is not installed.
- 253 Corrupt media
A source media (possibly EEPROM) for a data file is corrupt. This error is usually seen in conjunction with errors concerning a certain file.
- 300 Device-specific error
This is the device-specific error for devices that cannot detect more specific errors.

5 Instrument Messages

-330 Self-test failed

A self-test failure occurred. Report this error to Agilent Technologies.

-340 calibration failed

An expected file was not found while trying to load internal calibration.

Device-Specific Errors

- 102 Set 50 MHz signal < 0 dBm, do alignment again
The 50 MHz energy is too high at the RF port for alignments to run. Reduce input power to less than 0 dBm and run alignments again.
- 104 1st LO Unlock
The first LO on has lost phase lock. Report this error to the nearest Agilent Technologies sales or service office.
- 105 2nd LO Unlock
The second LO has lost phase lock. Report this error to the nearest Agilent Technologies sales or service office.
- 201 Option not installed
The desired operation cannot be performed because a required option is not installed.
- 204 TG Frequency Limit
The tracking generator has reached the limit of its allowable frequency range.
- 211 RBW limited to 1 kHz when Span > 1 MHz
In spans greater than 1 MHz, narrow (digital) resolution bandwidths, below 1 kHz, are not available.
- 213 Span limited to 1 MHz when RBW < 1 kHz
In narrow (digital) resolution bandwidths, below 1 kHz, spans greater than 1 MHz are not available.
- 214 TG start freq is less than 9 kHz
Tracking generator uncalibrated below 9 kHz.

- 215 TG start freq is less than 1/2 res bw
Tracking generator uncalibrated at start frequencies below 1/2 the current resolution bandwidth.
- 224 Option not licensed
The selected option requires a license. Refer to the installation procedures in the user guide provided for this particular option.
- 238 VBW filter or Average Detector cannot use both
- 501 RF over load
Either increase input attenuation or decrease the input signal level.
- 502 IF over load
Either increase input attenuation or decrease the input signal level.
- 604 File already exists
You attempted to save to a file that already exists. Either delete or rename the existing file or select a new name, then try again.
- 605 Media is protected
A save was attempted to a write-protected device.
- 610 File access is denied
The file is protected or hidden and cannot be accessed.
- 612 File not found
The analyzer could not find the specified file.
- 651 Connect TG OUT to RF IN
Attempt to align the tracking generator without its output connected. Connect the **TG SOURCE** to **RF IN**.

- 652 Connect CAL OUT to RF IN
you must connect the **CAL OUT** to **RF IN** with the appropriate cable.
- 751 Instrument state set to initial values
While trying to load a trace or state, the state information was found to be in error. This may be because the state had been stored on a later revision of analyzer firmware. A default set of state variables was loaded instead. There is nothing wrong with the analyzer.
- 752 Unable to load state from file
Attempt to load a state from a file failed.
- 753 Unable to save state to file
Attempt to save a state to a file failed. See the associated error messages for the cause.
- 757 Unable to load user state
A user preset failed, so the factory preset values were used. Save a valid state into user preset and try again.
- 758 Unable to save user state
Attempt to save a user preset state failed.
- 760 Unable to query state
Query of state over the remote interface was unsuccessful.
- 762 Unable to load file
A failure occurred while loading a file.
- 764 Unable to save file
Attempt to save a file failed; the file was not saved.

- 767 Fatal LDS error
Attempt to initialize the instrument state has failed. Cycle instrument power. If this fails to correct the problem, contact your nearest Agilent Technologies service center.
- 768 Unable to load user state
Attempt to load a state failed, because the state was saved with a measurement personality that is not currently loaded. Load the appropriate personality and try again.
- 770 Incorrect filename
You sent a remote command to save a screen file but did not specify a valid extension.
- 780 No Peak Found
No signal peak was found that meets the criteria under **Peak Search > Peak Criteria**.
- 781 Video Trigger cannot be active
You sent a remote command to do one of the following:
- Turn on video trigger while the Average Detector or a Marker Function is active.
 - Turn on the Average Detector or a Marker Function while Video Trigger is active.
- 782 Video Trigger cannot be used with Mkr Func
Due to the Average Detector, the video Trigger cannot be used with Maker function.
- 783 Allowable span for current CF exceeded
- 784 Allowable CF for current span exceeded
- 805 Doing Alignment



6 Troubleshooting

This chapter includes information on how to check for a problem with your Agilent Technologies spectrum analyzer, and how to return it for service.

If you experience a problem or would like additional information about your analyzer, Agilent Technologies' worldwide organization is ready to provide the support you need.

Check the basics

Before calling Agilent Technologies, or returning an analyzer for service, perform the quick checks listed below. This check may eliminate the problem.

- Is there power at the receptacle?
- Is the analyzer turned on? Listen for internal fan noise to determine if the analyzer cooling fan is running. Feel the rear side of the analyzer for air flow.
- If other equipment, cables, and connectors are being used with your spectrum analyzer, make sure they are connected properly and operating correctly.
- Review the measurement procedures being performed when the problem first appeared. Make sure all of the settings are correct.
- If the analyzer is not functioning as expected, return the analyzer to a known state by pressing **Preset**.

NOTE

Some analyzer settings are not affected by a Preset. If you wish to reset the analyzer configuration to the state it was in when it was originally sent from the factory, press System, Power On/Preset, Preset Type, Factory. Then press the green Preset key on the front panel.

- Is the measurement being performed, and the results that are expected, within the specifications and capabilities of the analyzer? Refer to the *Technical Overview* for your analyzer.
- Is the analyzer displaying an error message? If so, refer to *User's Guide* for details.
- To meet specifications, the analyzer must be aligned. For more information on how to align the analyzer, refer to [“Time Base Calibration”](#) on page 23.

WARNING

No operator serviceable parts inside. Refer servicing to qualified personnel. To prevent electrical shock, do not remove covers.

NOTE

If the analyzer is still under warranty or is covered by a maintenance contract, it will be repaired under the terms of the warranty or plan (the warranty is located at the front of this manual).

If the analyzer is no longer under warranty or is not covered by an Agilent Technologies maintenance plan, Agilent Technologies will notify you of the cost of the repair after examining the analyzer.

If a problem persists, please contact the Agilent Technologies office for further information and service.

Warranty and Service Options

Agilent N9322C spectrum analyzer provides 1-year return-to-Agilent warranty as standard.

Agilent Technologies offers several optional maintenance plans to service your analyzer after the warranty has expired:

R-51B-001-3C

extends this service to 3 years.

R-50C-011-3

Agilent calibration upfront support plan, 3-year coverage.

The calibration cycle of N9322C spectrum analyzer is one year.

NOTE

A button cell provides power to the real time clock of the spectrum analyzer. It is not rechargeable. If you find your N9322C encounters a clock defect, please contact your nearest Agilent Customer Contact Center (CCC) for service.

Contact Agilent Technologies

Agilent Technologies has offices around the world to provide you with complete support for your spectrum analyzer. To obtain servicing information or to order replacement parts, contact the Agilent Technologies customer contact center listed below. In any correspondence or telephone conversations, refer to your spectrum analyzer by its product number and full serial number..

Online assistance: <http://www.agilent.com/find/assist>

United States

(tel) 800 829 4444
(fax) 800 829 4433

Canada

(tel) 877 894 4414
(fax) 800 746 4866

China

(tel) 800 810 0189
(fax) 800 820 2816

Europe

(tel) +31 20 547 2323
(fax) +31 20 547 2390

Japan

(tel) +81 426 56 7832
(fax) +81 426 56 7840

Korea

(tel) 080 769 0800
(fax) 080 769 0900

Latin America

(tel) +1 (305) 269 7500

Taiwan

(tel) 0800 047 866
(fax) 0800 286 331

Australia

(tel) 1 800 629 485
(fax) +61 (3) 9210 5947

Other Asia Pacific Countries

(tel) +65 6375 8100
(fax) +65 6755 0042
Email: tm_ap@agilent.com



7 Menu Maps

This chapter provides a visual representation of the front panel keys and their associated menu keys (in Spectrum Analyzer mode). Refer to [Chapter 4, “Key Reference,”](#) starting on page 101 for key function descriptions.

The name editor menu is shown separately, though it is accessed when entering data for many keys. The front-panel key menus appear in alphabetical order as follows.



Amplitude Menu

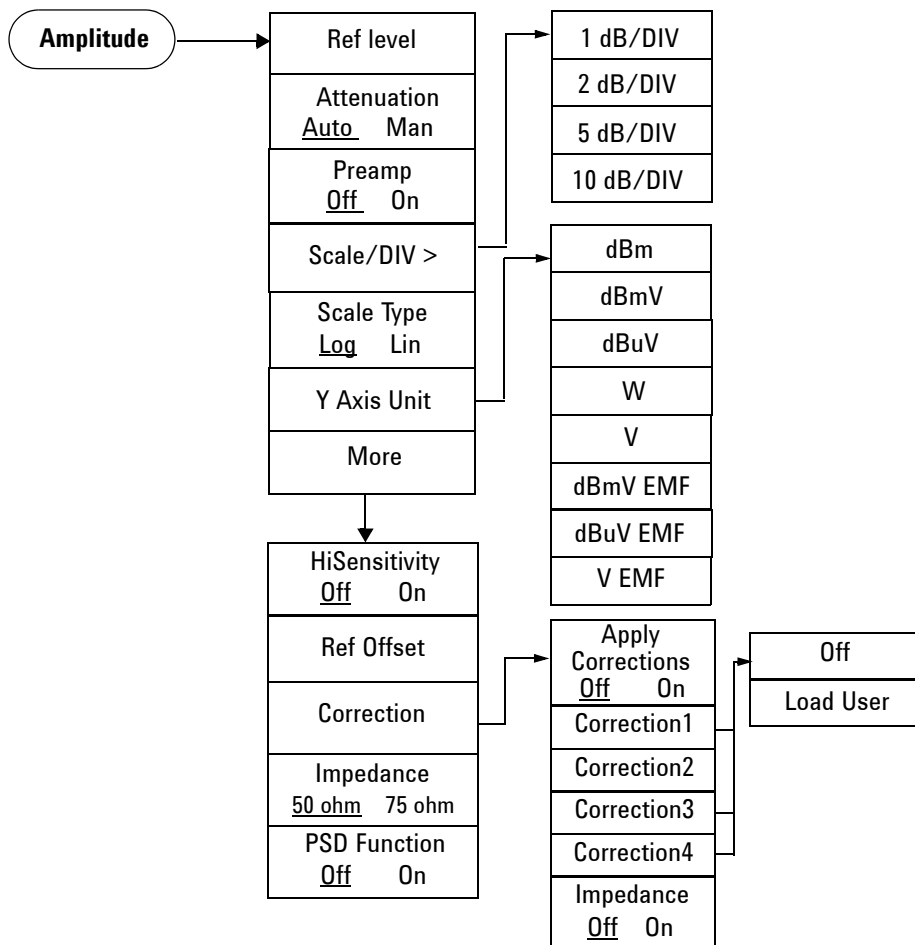

BW Menu

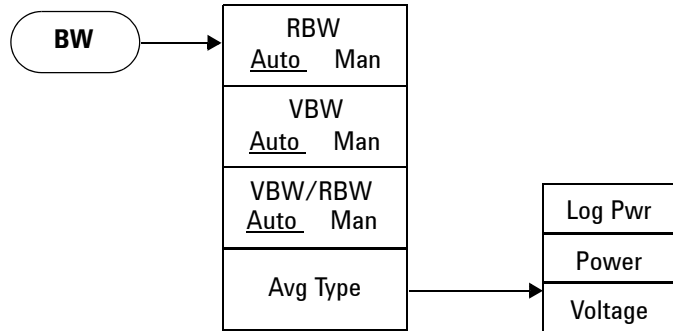

Sweep Menu

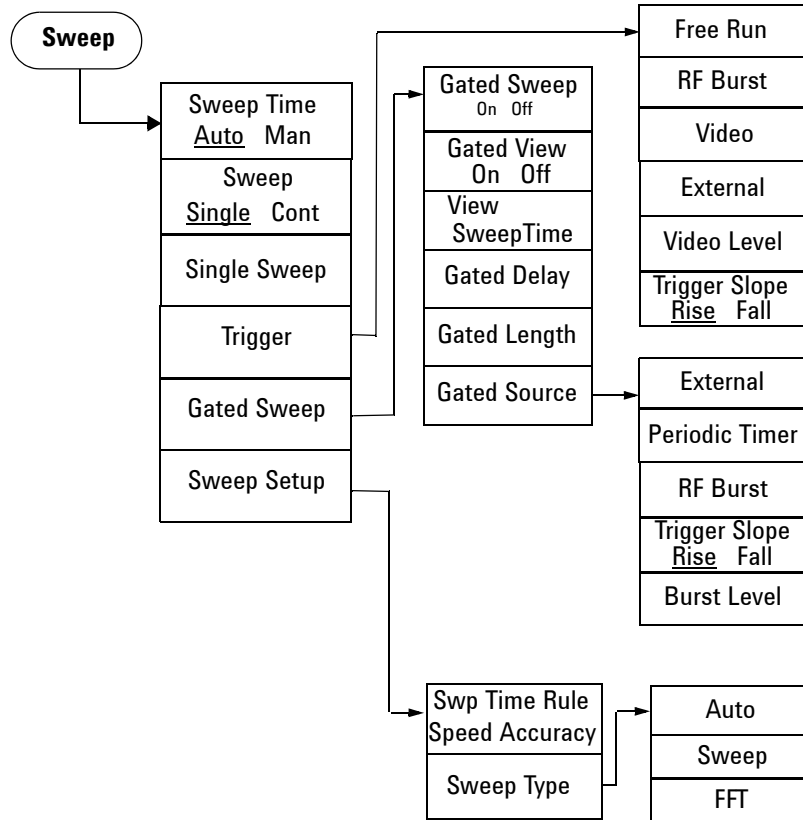

Display Menu

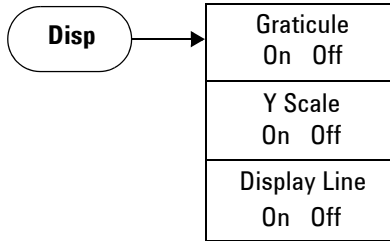

*This menu map is for **Spectrum Analyzer** mode.

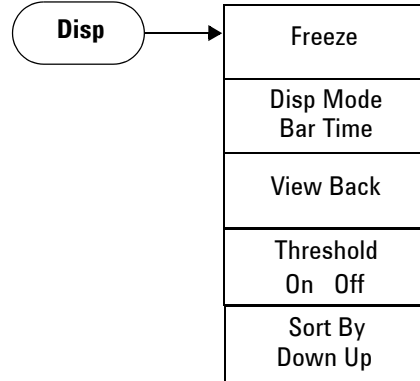

*This menu map is for **Channel Scanner** measurement.

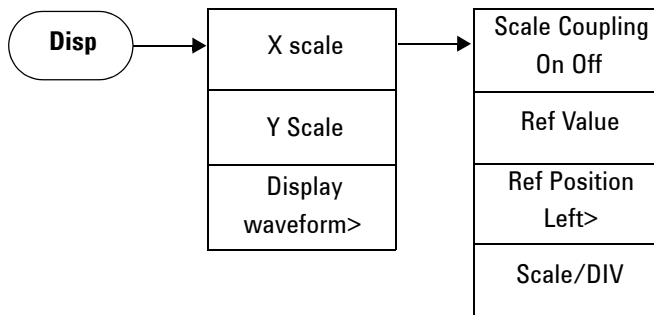

*This menu map is for **ASK/FSK** modulation analysis.

File/Mode - Task Planner

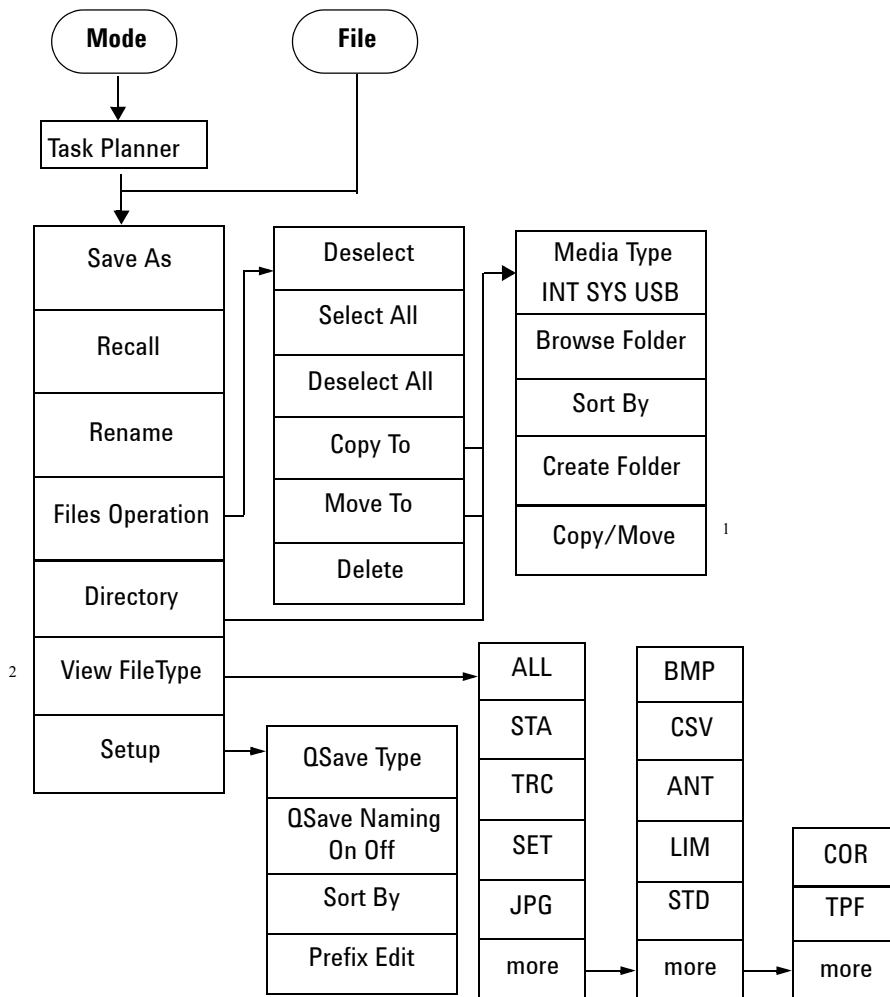

¹ *The softkey *Copy/Move* only exists in the submenu of *Copy To/Move To*.

² *The softkey *View FileType* is fixed as TPF in Task Planner Mode.

Frequency Menu

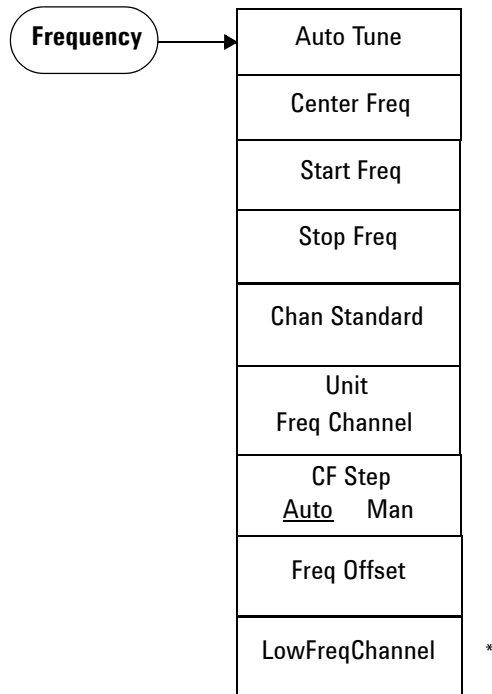

*This softkey is only visible when option BB1 is installed.

Limit Menu

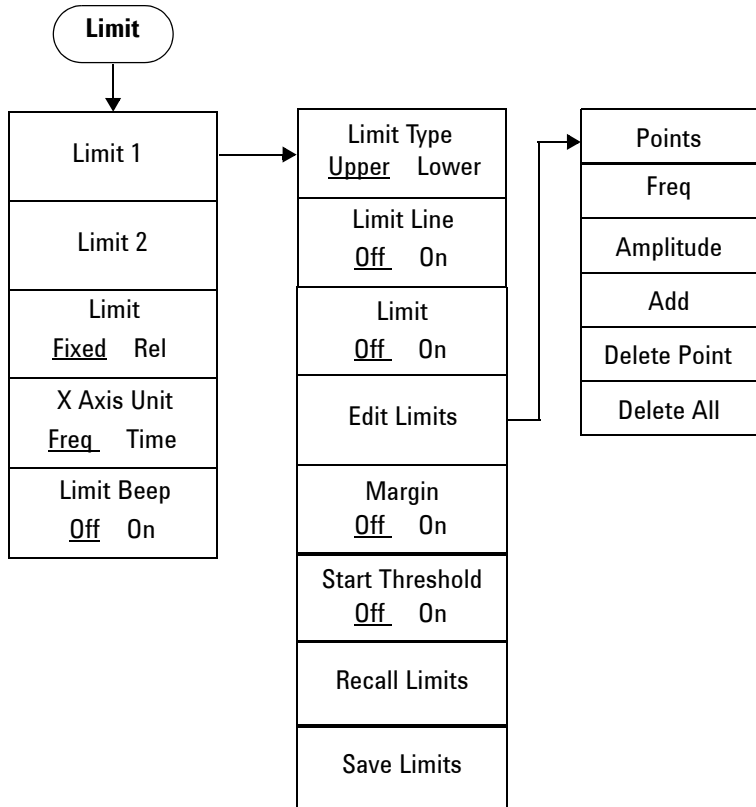

Marker Menu

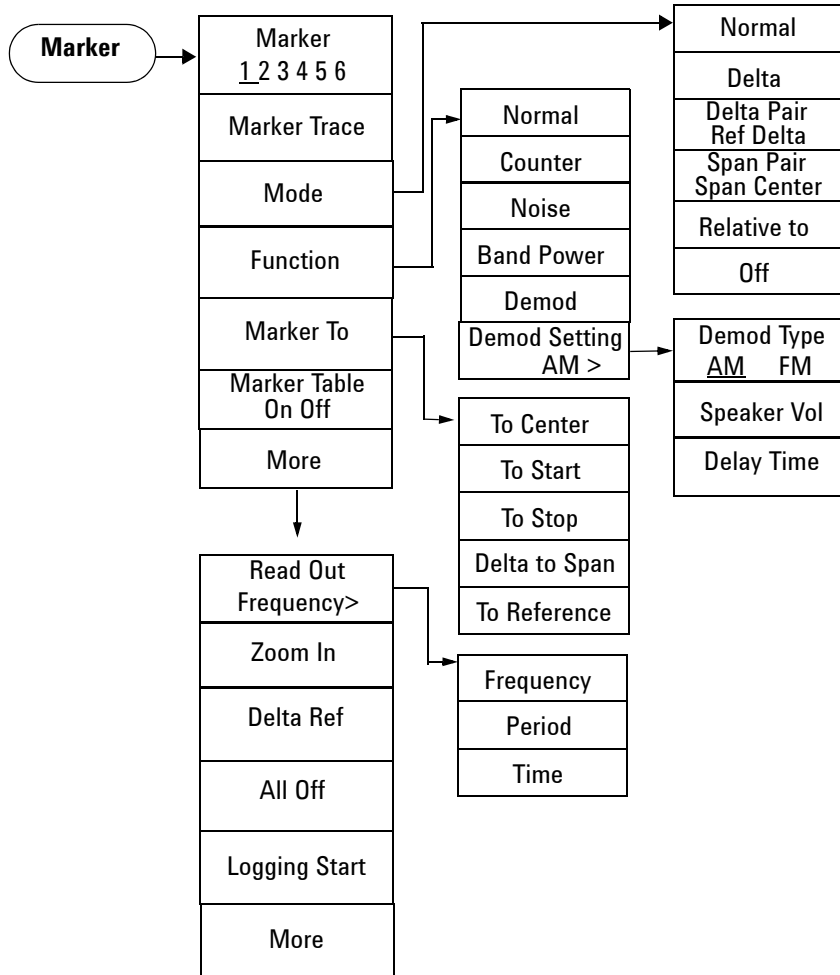

Peak Search Menu

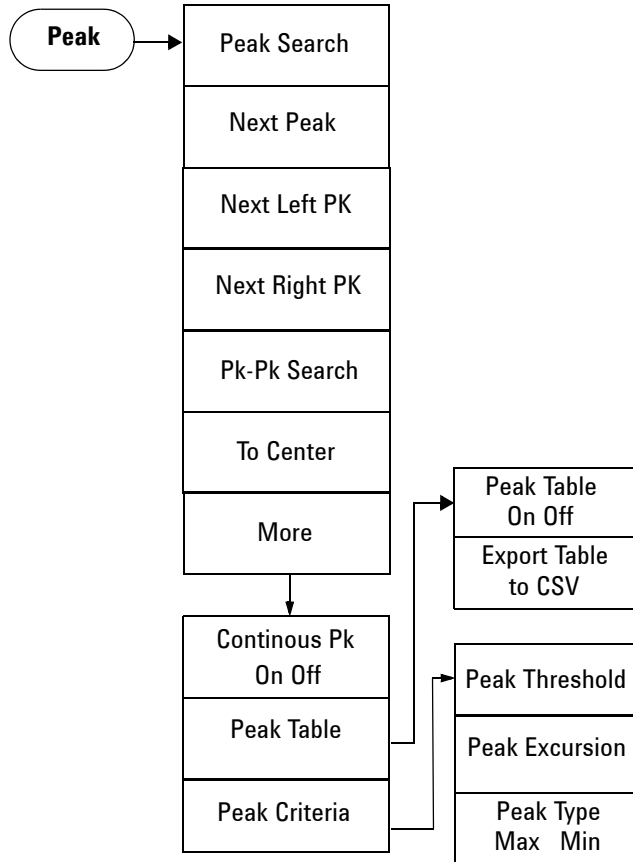

Measure Menu (1 of 2)

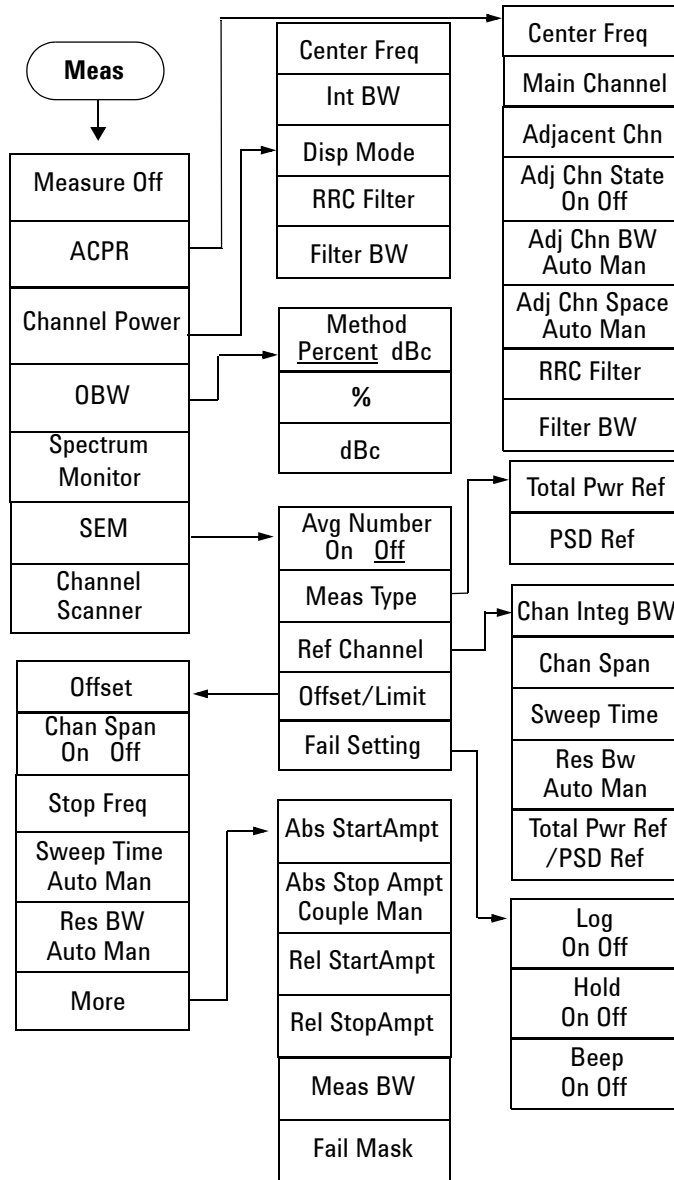

Measure Menu (2 of 2)

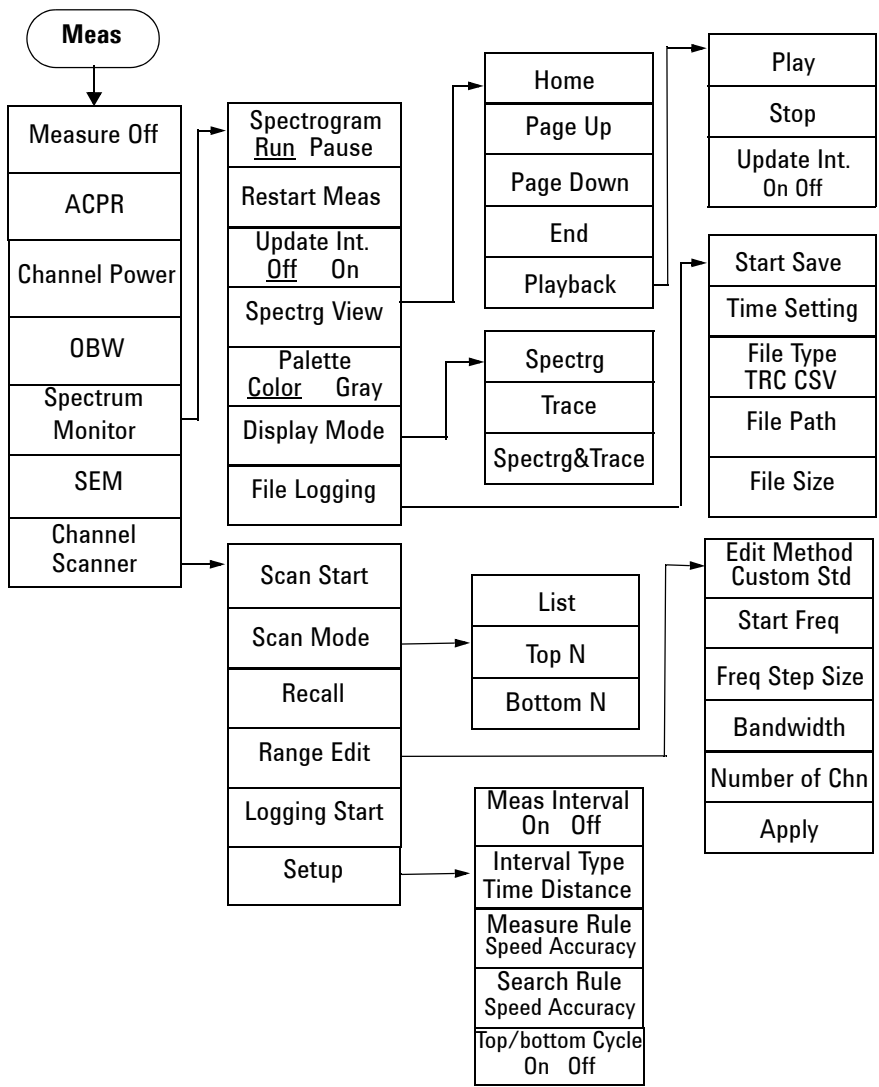

Mode - Tracking Generator

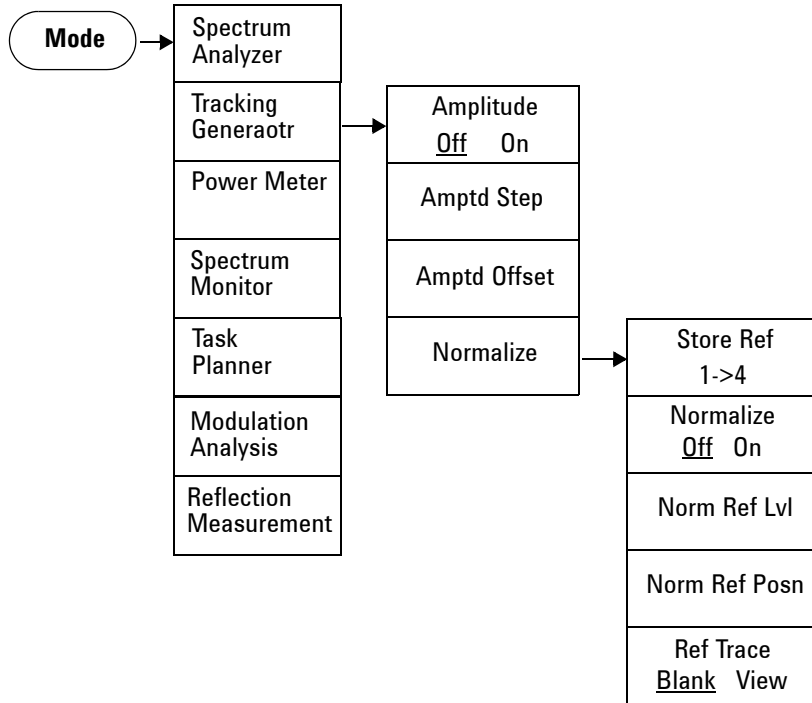

Mode - Power Meter

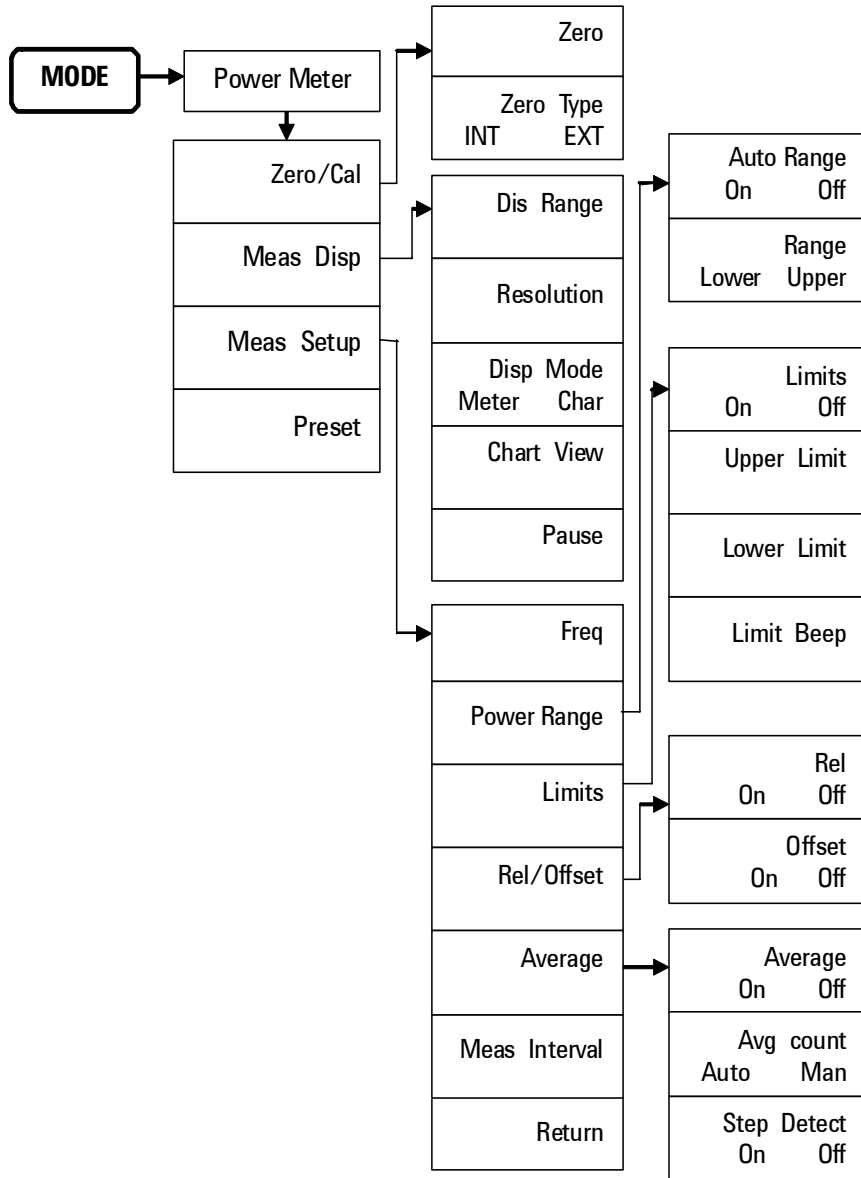

Mode - AM/FM Modulation Analysis

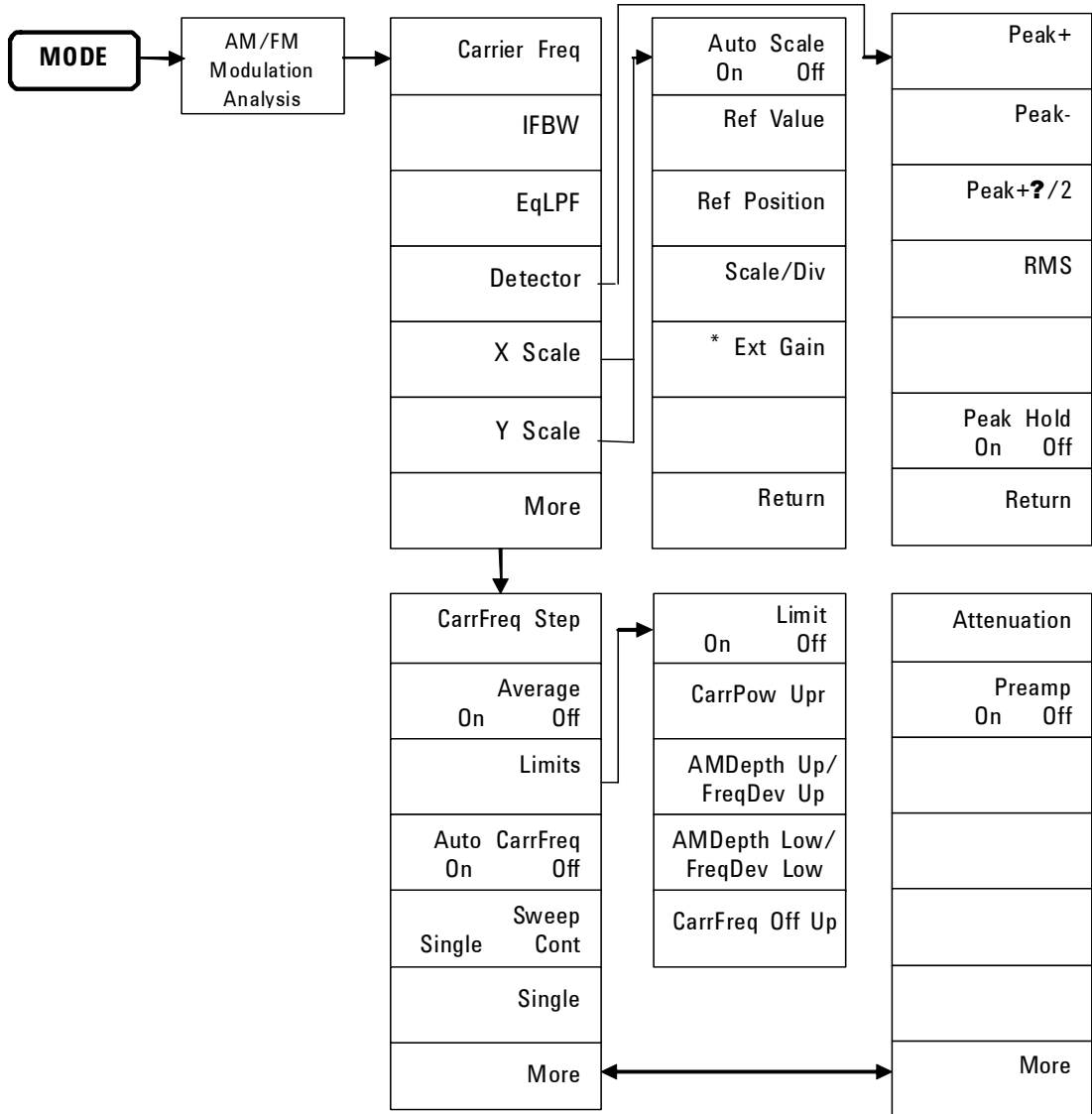

* **Ext Gain** is only available in **Y Scale** submenu.

Mode - ASK/FSK Modulation Analysis

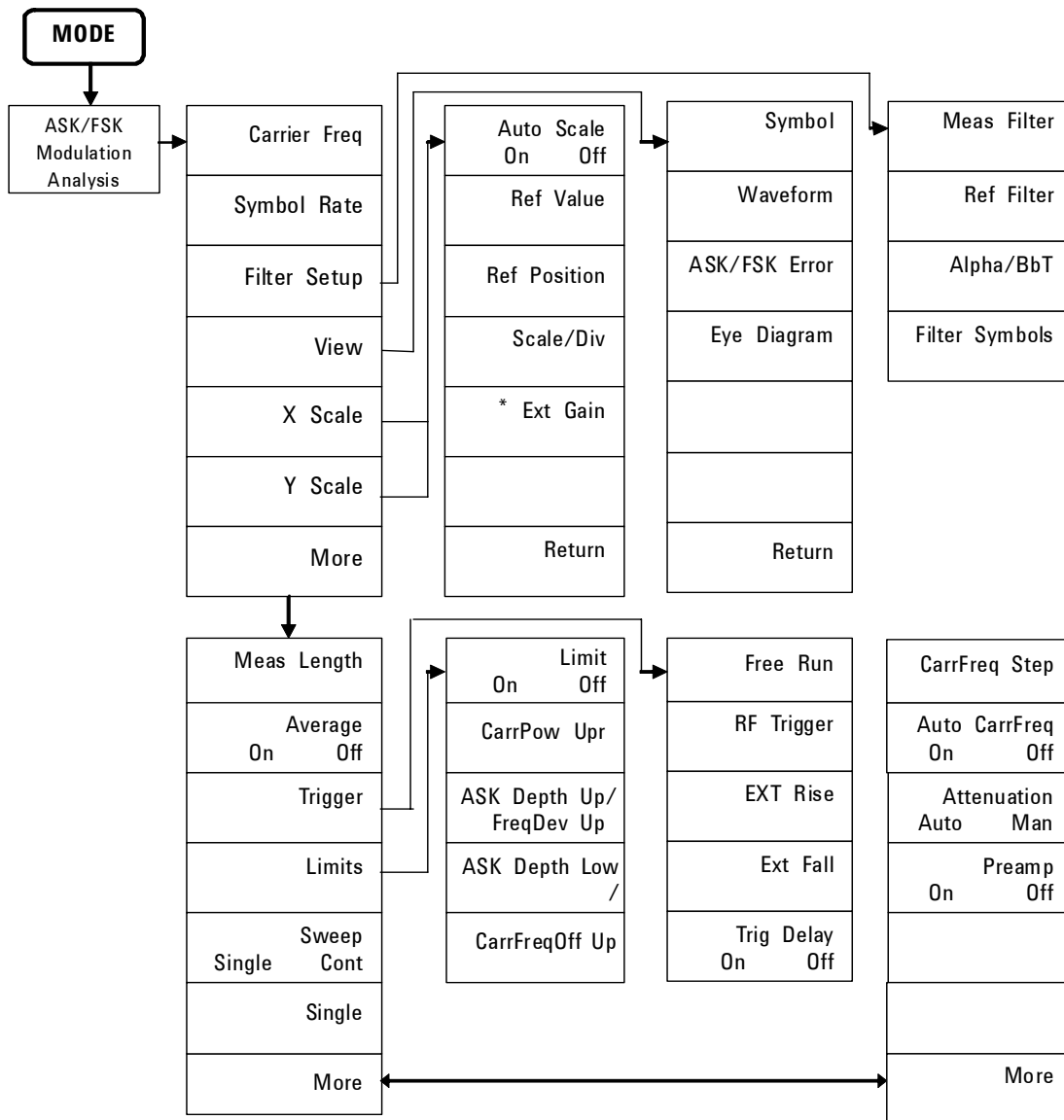

Mode - Reflection Measurement

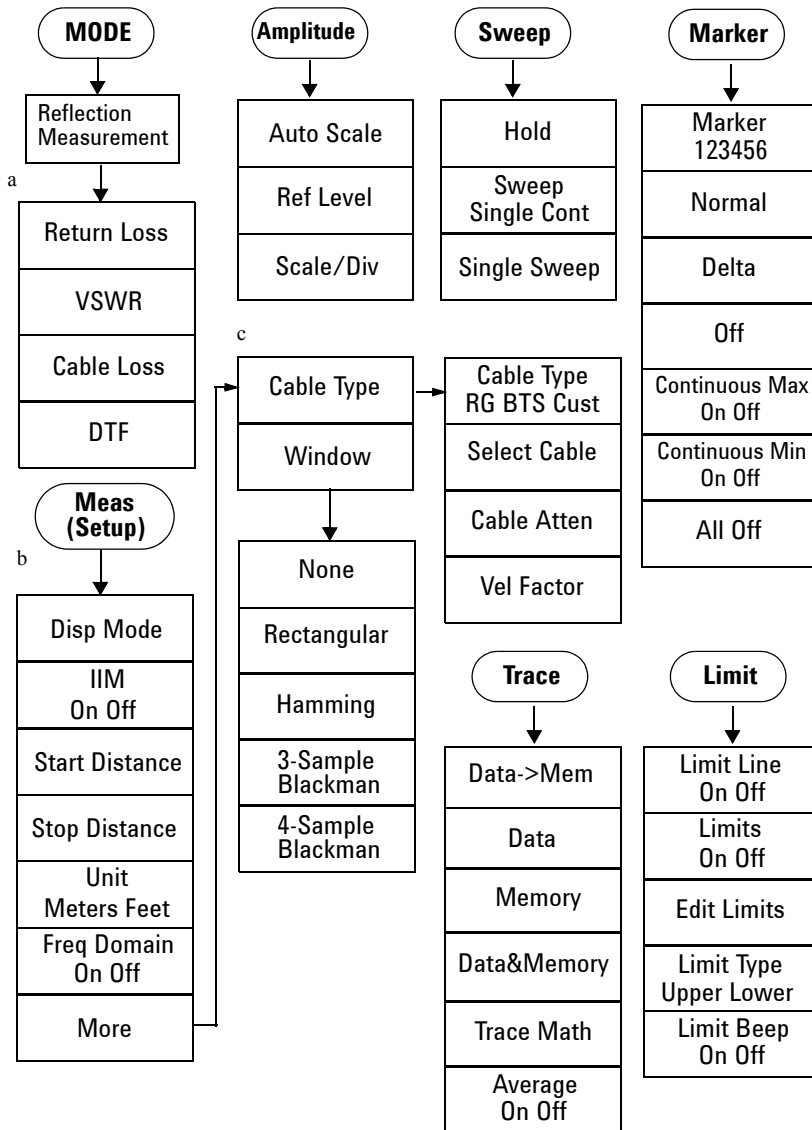

- Press Meas twice to toggle the submenu between Meas setup and Mode setup.
- The Meas submenu is specific for DTF measurement.
- The Cable Type and Window submenu is specific for DTF measurement.

Name Editor Menu

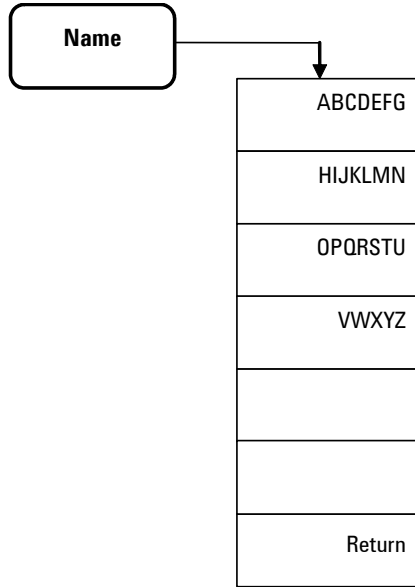

System Menu

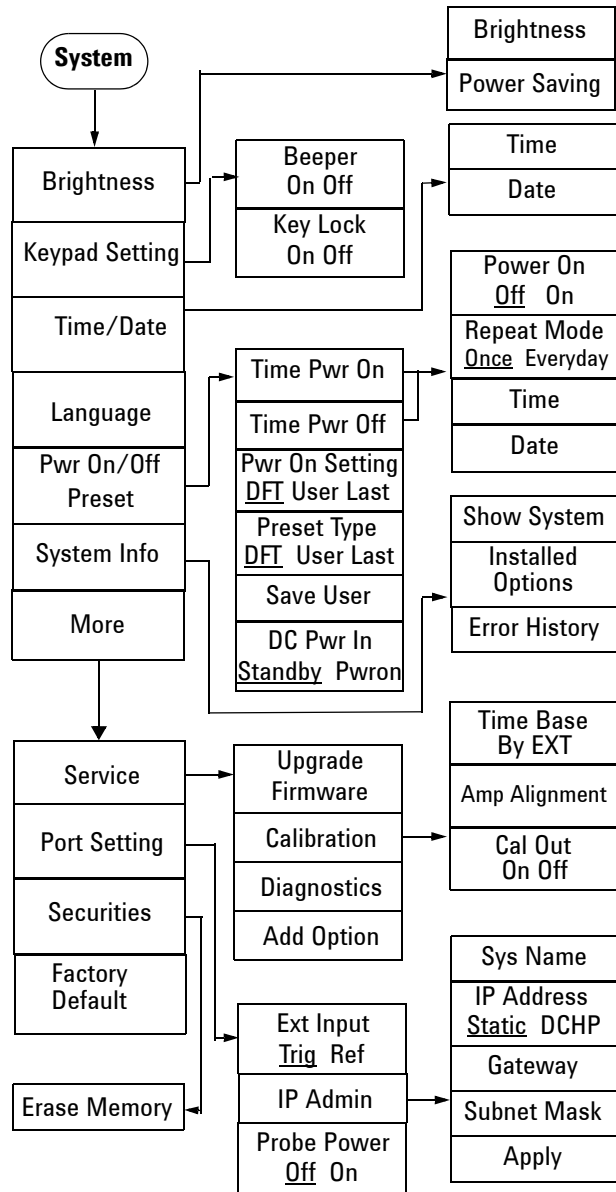

SPAN Menu

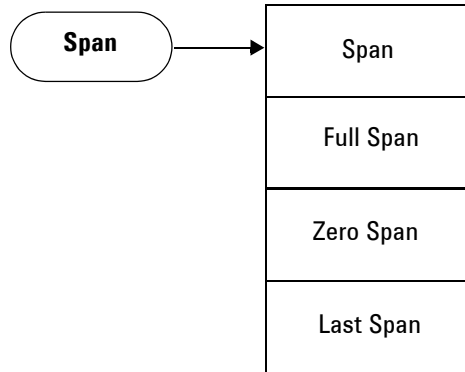

Trace/Det Menu

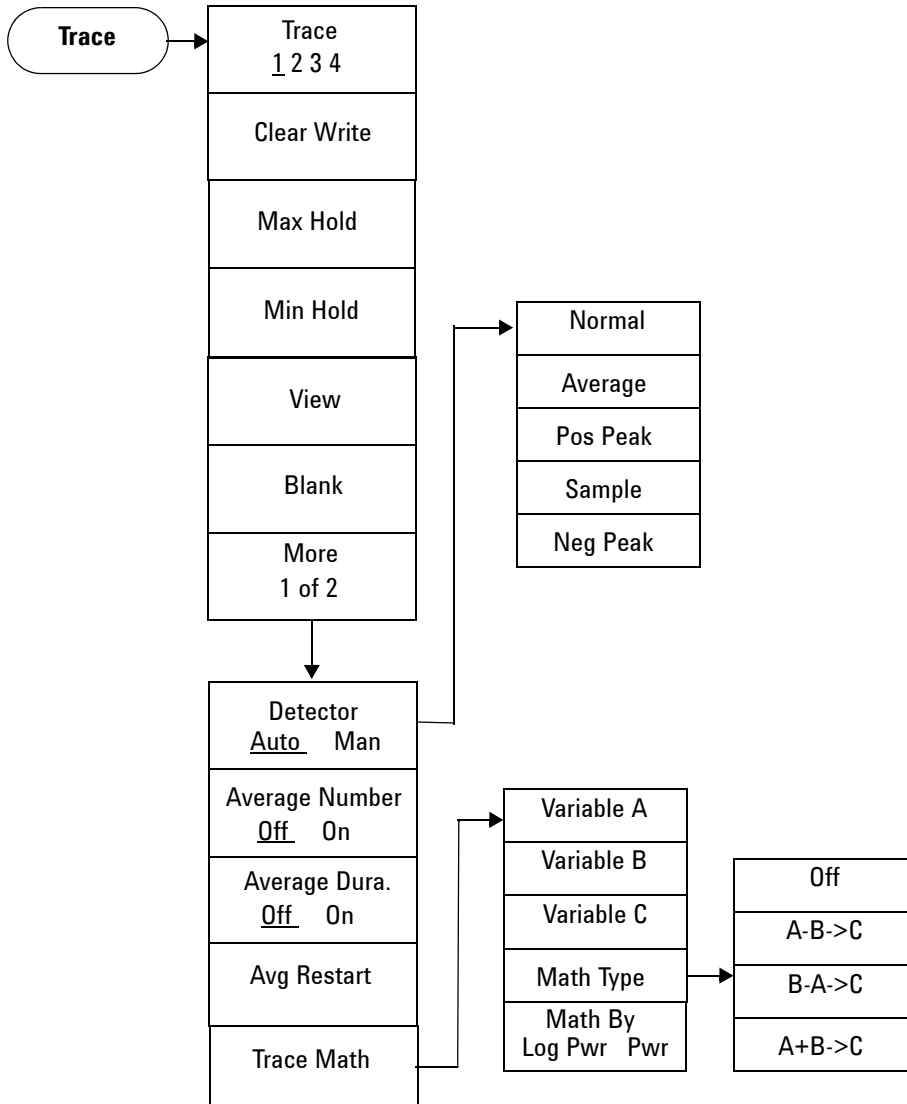

Index

Numerics

3GPP W-CDMA, 126
802.11a, 127
802.11b, 127

A

Abs Start, 128
Abs Stop, 128
adjacent channel power, 123
Amplitude key, 102
annotation, marker, 34
Attenuation, 102
attenuation, reducing, 44
Average, 164

B

BW/Avg key, 106

C

Calibrate, using T-combo, 71
calibration, freq change, 138
Calibration, span changes, 71
CE mark, 10
Center Freq, 111
CF Step, 112
channel power, 119
comparing signals
 off screen, 37
 on the screen, 35
Continuous PK, 149
CSA mark, 10
c-tick mark, 10

D

delta marker, 115
Det/Display key, 109
Detector, 163
distortion, measuring, 53
DTF Measurement, 73

E

Enter key, 110
error message, 17
ESC/CLR, 110
ESD, 21
external reference, 24

F

Fail Mask, 129
firmware revision, update, 25
front panel
 overview, 4
front panel, using, 30

H

harmonic distortion
 measuring, 53

I

improving frequency resolution and
 accuracy, 49
instruction manual, 10
instrument messages, 167
Int Preamp, 102

L

Limits, 159

M

Marker key, 114
Marker Table, 117
Meas key, 119
measuring
 ACP, 123
 channel power, 119
 distortion, 53
 low-level signal, 44
 multiple signals, 35
 occupied BW, 121
 SEM, 124
 source's frequency drift, 51
 TOI, 56
menu maps, 181
messages, 17
MODE key, 130

N

Next Peak, 148

O

occupied BW, 121
Offset/Limits, 125
options
 enable, 24
order list, 12

P

Peak Search key, 148
power cord, 14
power requirements, 14
preset
 factory, 31
 user, 31

Index

Preset/System key, 151
Pwr on/Preset, 151

R

rack mount, 19
Ref level, 102
Rel Start, 128
Rel Stop, 129
requirements
 ventilation, 18
Res BW, 106
resolving signals
 equal amplitude, 39
 hidden by large signals, 42

S

Scale/Div, 102
Search Criteria, 149
Show System, 152
SPAN key, 154
spectrum emission mask, 124
Start Freq, 111
Stop Freq, 111
symbols, 10

T

TOI
 measuring, 56
tracking drifting signals, 51

U

Uncoupled, definition, 47
using frequency counter, 49

V

VBW/RBW, 106
ventilation, 18
Video BW, 106
View/Trace key, 162
viewing signal, 33

W

WEEE, 10



Manufacturer's Name: Agilent Technologies (Chengdu) Co., Ltd.

Manufacturer's Address: No. 116, 4th Tian Fu Street
Chengdu Hi-Tech Industrial Development Zone (South),
Chengdu, 610041, China

Declares under sole responsibility that the product as originally delivered

Product Name: Spectrum Analyzer

Model Number: N9322C

Product Options: This declaration covers all options of the above product(s)

complies with the essential requirements of the following applicable European Directives, and carries the CE marking accordingly:

Low Voltage Directive 2006/95/EC
EMC Directive 2004/108/EC

and conforms with the following product standards:

EMC	Standard	Limit
	IEC 61326-2-1:2005 / EN 61326-2-1:2006	
	<i>Reference Standards</i>	
	CISPR 11:2003 / EN 55011:2007	Class A Group 1
	IEC 61000-4-2:2001 / EN 61000-4-2	4 kV/4 kV contact/air
	IEC 61000-4-3:2002 / EN 61000-4-3	3 V/m, 80-2000 MHz, 1 V/m, 2-2.7 GHz
	IEC 61000-4-4:2004 / EN 61000-4-4	0.5 kV signal lines, 1 kV power lines
	IEC 61000-4-5:2001 / EN 61000-4-5	0.5 kV line-line, 1 kV line-ground
	IEC 61000-4-6:2003 / EN 61000-4-6	3 V, 0.15-80 MHz
	IEC 61000-4-11:2004 / EN 61000-4-11	1 cycle, >95%

Canada: ICES/NMB-001:2006
Australia/New Zealand: AS/NZS CISPR 11:2004

The product was tested in a typical configuration with Agilent Technologies test systems.

Safety IEC 61010-1:2010(3rd Edition) / EN 61010-1:2010(3rd Edition)
Canada: CAN/CSA-C22.2 No. 61010-1-04,
USA: ANSI/UL 61010-1:2004,

Supplementary Information:

This DoC applies to above-listed products placed on the EU market after:

Oct 23, 2012
Date

Shi Wen
Quality Manager

For further information, please contact your local Agilent Technologies sales office, agent or distributor,
or Agilent Technologies Deutschland GmbH, Herrenberger Straße 130, 71034 Böblingen, Germany.

www.agilent.com

© Agilent Technologies, Inc. 2012

Printed in China
First Edition, Nov 2012



N9322-90002

