

Optoelectronic IC/Component Evaluation

Quick Bench-top Evaluation of ICs and Electronic Components

Agilent B2900A Series of Precision Source/Measure Units facilitates quick DC evaluation of optoelectronic components such as optocouplers.



B2912A (front view)



B2912A (rear view)

DC evaluation of optoelectronic IC's/components

- An optoelectronic IC or component typically consists of an emitting device (like an LED) and photo detectors (PDs). This arrangement requires the simultaneous DC evaluation of both devices.
- A pair of source/measure units (SMUs) is the ideal choice to make flexible DC measurements on both the LED and PD.
- To illustrate this, two measurement examples of an off-the-shelf optocoupler are outlined in this document.

Measurement examples

■ Example 1: LED forward voltage

This is the most basic optoelectronic device measurement. Only one SMU is used to source and measure the LED. The B2900A's graphical display lets you directly view the IV curve.

■ Example 2: Input photo diode current transfer ratio

Measuring how efficiently light is transferred from the LED to the PD is essential for optocouplers. In this example, SMU1 is used to source forward current to the LED, while SMU2 monitors the generated current as it changes the reverse bias voltage across PD1.

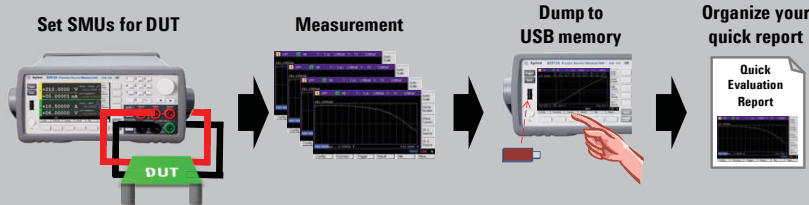

What is Quick Bench-top Evaluation?

The B2900A series does not require a PC to make measurements on the bench-top. You can view graphical measurement results on the B2900A and save the graphs and data to any USB memory device, thereby improving the efficiency of your bench-top evaluation and debugging. Of course, if you prefer using a PC to control the B2900A then you can download Agilent's free Quick I/V Measurement Software from our website.

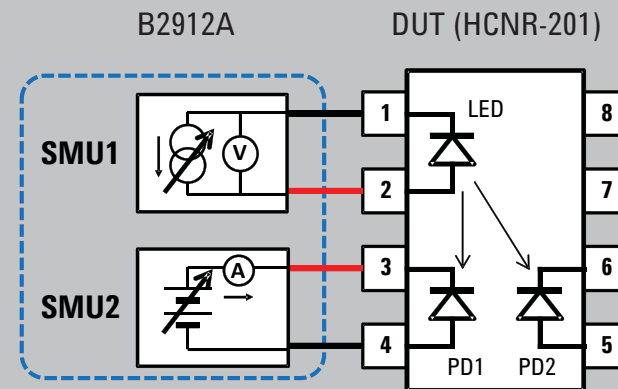

DUT and SMU setup

Note: HCNR-201 is a product of Avago Technologies



Agilent Technologies

Example 1: LED forward voltage

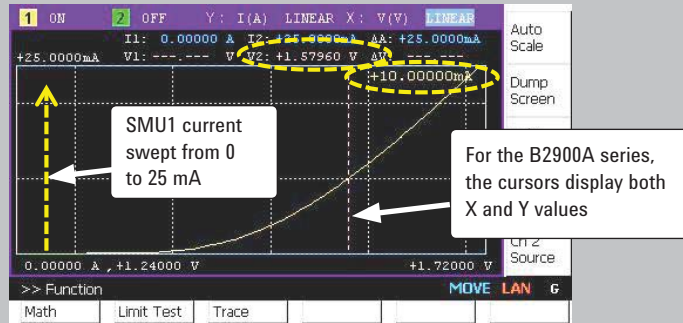

IV characteristics for LED

IV characteristics are an essential measurement for diode class devices. Using SMU1 to sweep current, you can graphically monitor the forward LED voltage. The cursor shows the forward voltage at $I_F = 10\text{ mA}$ is approximately 1.58 V.

Tip: If you only need to make a single-point measurement, then Single View mode shows the result as an alphanumeric display.



Single View mode

Example 2: Input photo diode current transfer ratio

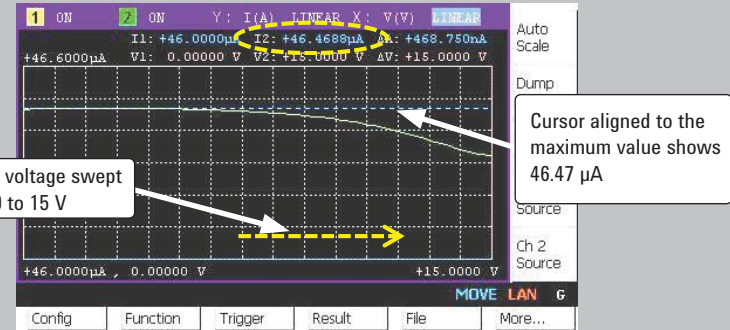

PD1 current vs. PD1 bias voltage

The transfer ratio indicates how efficiently photo current from the LED is converted to photo current in PD1. SMU1 sources 10 mA forward current to the LED, and SMU2 measures the photo current by applying a reverse bias voltage from 0 to 15 V.

The cursor shows the photo current is virtually stable at 46.4 μA across the bias range. Therefore the transfer ratio can be calculated to be 0.46 %.

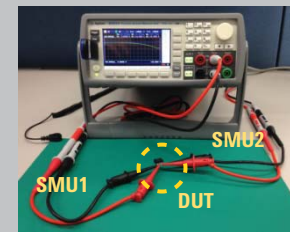

Measurement setup

How broad is the B2900A series capability?

- The specifications below cover most bench-top IC evaluation needs.

Product Number	Number of channels	Max output		Min source resolution	Min measure resolution	Min timing interval	Viewing mode
		DC	Pulse				
B2901A	1	210 V 3.03A	200 V 10.5 A	1 pA 1 μV	100 fA 100 nV	20 μs	Single graph
B2902A	2	210 V 3.03A	200 V 10.5 A	1 pA 1 μV	100 fA 100 nV	20 μs	Single, dual, graph
B2911A	1	210 V 3.03A	200 V 10.5 A	10 fA 100 nV	10 fA 100 nV	10 μs	Single, graph, roll
B2912A	2	210 V 3.03A	200 V 10.5 A	10 fA 100 nV	10 fA 100 nV	10 μs	Single, dual, graph, roll

Related Applications

- ✓ Infrared communications
- ✓ Photo-interrupters
- ✓ Proximity sensors
- ✓ Photo-reflectors
- ✓ Optoelectronic IC's
- ✓ Photovoltaic devices
- ✓ Distant Measurement
- ✓ Other LED and PD based IC's/components
- ✓ Laser diode applications

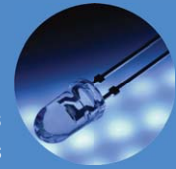

To Learn More...

Please visit our website below:

www.agilent.com/find/b2900a

www.agilent.com

Product specifications and descriptions in this document subject to change without notice

© Agilent Technologies, Inc. 2013
Printed in USA, May 23, 2013
5991-0015EN



Agilent Technologies